



Sci  
N  
Supplement to Nature,  
June 2, 1892

# Nature

A WEEKLY

38

LIBRARY OF THE  
MUSEUM OF COMPARATIVE ZOOLOGY  
HARVARD UNIVERSITY  
CAMBRIDGE, MASS.

ILLUSTRATED JOURNAL OF SCIENCE

VOLUME XLV

NOVEMBER 1891 to APRIL 1892

505508  
15. 3. 50

*"To the solid ground  
Of Nature trusts the mind which builds for aye."*—WORDSWORTH

London and New York  
MACMILLAN AND CO.

1892

Q  
—  
N2  
v. 45  
cop. 2

RICHARD CLAY AND SONS, LIMITED  
LONDON AND BUNGAY



# INDEX

- AALIA PAKAI, the Salt Lake of, A. B. Lyons, 29  
Abbe (Prof. C.), Cloud-Observations at Sea, 70  
Aberrant Fossil Ungulates of South America, 608  
Aberration, Lord Rayleigh, Sec. R.S., 499  
Aberration Problems, Prof. O. Lodge, F.R.S., 549  
Aberration, Theory of Astronomical, M. Mascart, 68  
Abney (Capt.), Colour Photometry, 213  
Aborigines of the Dominion of Canada, Hon. E. Dewdney, 587  
Abraham (R.), a Standard Condenser, 528  
Accidents in Germany, Workmen Killed and Wounded in, Vacher, 350  
Acloque (A.), Les Champignons, 222  
Acoustics: Refraction and Velocity of Sound in Porous Bodies, 156  
Acquired Characters, Inheritance of, Alfred W. Bennett, 53  
Acromegaly: the Skeleton of the Irish Giant Cornelius Magrath, Dr. D. J. Cunningham, F.R.S., 147  
Across Thibet, Gabriel Bonvalot, 269  
Adami (J. G.), Contributions to the Physiology and Pathology of the Mammalian Heart, 451  
Adams (Prof. John Couch): Obituary Notice of, 301; the Cambridge Philosophical Society and, 322; Proposed National Monument to, 401  
Adamsbrooke (G. L.), Aluminium and its Application to Photography, 134  
Adelsberg Cave, the, 207  
Adhesion, the Limpet's Power of, Percy A. Aubin, 464  
Æolosoma, Formation of a Temporary Cyst in the Fresh-water Annelid, Frank E. Beddard, 28  
Aërial Locomotive Machines, Use of Chronophotography for Study of, Marey, 71  
Aërodynamics, Experiments in, Lord Rayleigh, F.R.S., 108  
Africa: Projected Expedition by Dr. Oscar Baumann in East, 65; Equatorial, My Personal Experiences in, as Medical Officer of the Emin Pasha Relief Expedition, Thos. Heazle Parke, 265; Travels in Africa during the years 1879-83, Dr. Wilhelm Junker, 507; My Second Journey through Equatorial Africa, Hermann von Wissmann, 507; Two African Explorers, 376; Captain Dundas's Expedition in East, Mount Kenia, Ernest Gedge, 566; African Diamond Industry, the South, at the Chicago Exhibition, 567  
Agassiz (Prof. Alex.), Dredging Operations in the Eastern Pacific, 281  
Agriculture: Results of Experiments in, at Rothamsted, on the Question of the Fixation of Free Nitrogen, Dr. J. H. Gilbert, F.R.S., 32; Agricultural Department, Victoria, Results of the Travelling Dairy, A. Crawford, 39; the Weather Bureau of the United States, 86; the Reclaiming and Cultivation of Land in the Camargue, M. Chambrelant, 143; Principles of Agriculture, 173; the Value of Maize as Food, 234; Elements of Agriculture, Dr. W. Fream, 388; the Average Yield of Wheat in Ohio, 420; Proposed Establishment of an Agricultural College in British Guiana, 520; Agricultural Needs of India, 588; Journal of the Royal Agricultural Society, 568  
Air Temperature, Sun-spots and, 271  
Air and Water, Vivian B. Lewes, 531  
Airy (Sir George Biddell), Obituary Notice of, 232  
Aitken (John, F.R.S.), on the Number of Dust Particles in the Atmosphere of Various Places in Great Britain and on the Continent, with Remarks on the Relation between the Amount of Dust and Meteorological Phenomena, 299  
Alaska, the Boundaries of; the Geographical Position of Mount St. Elias, I. C. Russell, 472  
Alder (H. St. A.), Scientific Nomenclature, 104  
Algol, Dr. S. C. Chandler, 446  
Alkali-maker's Hand-book, by George Lunge, Ph.D., and F. Hurter, Ph.D., Prof. T. E. Thorpe, F.R.S., 121  
Allbutt (Dr. T. C., F.R.S.), Appointment of, to be Regius Professor of Physic in room of late Sir Geo. Paget, 402  
Allison (Mrs.), the Similkameen Indians of British Columbia, 164  
Alloys, Prof. W. C. Roberts-Austen, F.R.S., Report to the Alloys Research Committee of the Institution of Mechanical Engineers, 22  
Aloi (Prof.), Influence of Electricity on Growth of Plants, 520  
Alpine Rubi, T. D. A. Cockerell, 320  
Alternate Currents of High Potential and Frequency, Lectures on, Nikola Tesla, 345  
Altitudes, Astronomical Possibilities at Considerable, Prof. Pickering, 498  
Alum Solution, T. C. Porter, 29  
Aluminium: and its Application to Photography, G. L. Addenbrooke, 134; the Manufacture and Use of, from an Engineering Point of View, A. E. Hunt, 568  
Amazons, Obituary Notice of Henry Walter Bates, F.R.S., the Naturalist of the, 398  
America: American Journal of Mathematics, 45; Spanish Arrangements for the Celebration of the Quatercentenary of the Discovery of America, 64, 567; American Meteorological Journal, 70, 189, 357, 597; American Journal of Science, 118, 310, 445, 622; American Superiority in Mechanics, Coleman Sellers, 157; the Utilization of the By-products of the Coke Industry, Dr. B. Terne, 157; McKinley Tariff and Scientific Instruments, 208; Fisheries of the Great American Lakes, 259; Fishing through the Ice in the Great American Lakes, 280; Remarkable Display of Aurora Borealis in, 378; Kalm's Account of his Visit to England, on his way to, in 1748, 412; American Society for Prevention of Cruelty to Animals, Report of, 496; Influenza in, Prof. Edward S. Holden, 582; American Town Trees, J. Robinson, 603; Forestry in, Prof. W. R. Fisher, 611; Ancient Civilization of Central, Alfred P. Maudslay, 617  
Amorphous Boron, the Properties of, A. E. Tutton, 522  
Amsterdam Royal Academy of Sciences, 48, 72, 240, 408, 576, 600  
Anatomy, Comparative: the Cranial Nerves of Man and Selachians, Prof. Cossar Ewart, 527  
Anatomy of the Dog, 16  
Ancient Civilization of Central America, Alfred P. Maudslay, 617  
Ancient Monuments, Orientation of, Rev. Fred. F. Grensted, 464  
Ancient Tombs and Burial Mounds of Japan, Prof. Hitchcock, 381  
Andalusite at Ariège, on the Relations existing between the Form and Nature of the Beds of, M. A. Lacroix, 624  
Andaman Islands, Disappearance of the Aborigines of the, 587  
Anderson (Thos. D.), the New Star in Auriga, 365  
Andes of the Equator, Travels among the Great, Edward Whymper, Prof. T. G. Bonney, F.R.S., 561  
Andoyer (M.), Orthochromatic Plates for Astronomical Photography, 280  
André (M.), the Spontaneous Oxidation of Humic Acid and Vegetable Soil, 288; the Manifestation of Negative Electricity during Fine Weather, 528  
Anemometer Comparisons, W. H. Dines, 623  
Anemometers, Two New Forms, in use at Key Observatory, 587  
Aneroid Barometer, How to Use the, Edward Whymper, 339

- Aneroid in Hypsometry, the, Herbert Tomlinson, F.R.S., 440
- Aneurism, a Treatise on the Ligation of the Great Arteries in continuity, with Observations on the Nature, Progress, and Treatment of, Chas. A. Ballance and Walter Edmunds, Dr. M. Armand Ruffer, 530
- Angot (A.), Instructions Météorologiques, 196
- Angot (M.), Temperature Observations in 1890 on Eiffel Tower, 234
- Ångström, the Chromosphere Line 6676·9, Rev. A. L. Cortie, 103; Heat-Radiation of Gases under the Electric Discharge, 306
- Animal Sketches, C. Lloyd Morgan, 291
- Animals, a Remarkable Book on the Habits of, W. H. Hudson, Dr. Alfred R. Wallace, 553
- Annals of the University Observatory in Vienna, 138
- Annelid *Eolozona*, Formation of a Temporary Cyst in the Fresh-water, Frank E. Beddard, 28
- Annelids : Preliminary Notice of a New Branchiate Oligochaete, Frank E. Beddard, 109
- Anthrax, Animals rendered immune to, Dr. Th. Weyl, 312
- Anthropogéographie, Friedrich Ratzel, 557
- Anthropology : Anthropological Society, 71, 164, 431, 503, 551; the Mexican Atlal, or Spear Thrower, 66, 103; the Limits of Savage Religion, Dr. Tylor, 71; Strange Symbolical Marriage Custom in India, Dr. Post, 135; the Similkameen Indians of British Columbia, Mrs. Allison, 164; Nature and Man in North America, Prof. N. S. Shaler, 220; Prof. Putnam's Exhibit at Chicago Exhibition, 259; the Transformation of the Animal Skull into a Human Skull, P. Topinard, 260; Discovery of Aboriginal Skulls in the Argentine, Señor Moreno, 278; Rev. Lorimer Fison on Anthropological Study, 426; Anthropogenic, oder Entwickelungsgeschichte des Menschen, Prof. Ernst Haeckel, 482; L'Anthropologie, 521; the Manchu Race, 523; the Ceremonial Circuit of the Cardinal Points among the Tusayan Indians, J. W. Fewkes, 546; Finds at the Great Zimbabwe Ruins, Theodore Bent, 551; Population of the Five Continents, Émile Levasseur, 552; Mission Scientifique de Cap Horn, J. Deniker and P. Hyades, 577; the Botocudos of Brazil, 615
- Anti-Taurus, the Eastern Taurus and the, D. G. Hogarth, 138
- Antipodes, Oysters at the, 43
- Antoine (Ch.), the Characteristic Equation of Water-vapour, 336
- Antwerp, proposed International Economic Congress at, 586
- Apertures, the Law of Limiting, Dr. E. J. Spitta, 186
- Aphanapteryx in the New Zealand Region, Prof. Henry O. Forbes, 580
- Apteryx, Additional Observations on Development of, T. J. Parker, F.R.S., 311
- Arabian Sea : Cyclones in the, 276; Cyclone Memoirs of the, W. L. Dallas, 135
- Archæology : Excavation of the Prehistoric Mounds in Ohio, 20; the Chronology of the Neolithic Age in Scandinavia, and the Bronze Age in the East and Southern Europe, Prof. Montelius, 39; Dr. Ermling on the Nurhagi of Sardinia, 114; the late Dr. Reinholm on Finnish Archæology, 496
- Architects, Institution of Naval, 570
- Architecture, Naval : the Steadying of Vessels at Sea, J. I. Thornycroft, 570; the Influence of Shallow Water upon the Trial Trip Speeds of Modern Vessels, W. H. White, F.R.S., 571; on Balancing Marine Engines and the Vibration of Vessels, A. F. Yarrow, 571
- Arctic Plants, Fresh Evidence concerning the Distribution of, during the Glacial Epoch, Dr. A. G. Nathorst, 273
- Arendt (Dr.), Relationship of Atmospheric Electrical Phenomena to Terrestrial Magnetism, 432
- Argentine, Discovery of Aboriginal Skulls in the, Señor Moreno, 278
- Arithmetic, Chemical, Problems in, E. J. Cox, 293
- Arithmetic, Mental, Clive Cuthbertson, 78; Dr. K. Haas, 198
- Arithmetic for Schools, Chas. Smith, 247
- Arithmetical Exercises in Chemistry, Leonard Dobbin, 76
- Arizona, the Prehistoric Irrigation Canals of, 185; the Native Iron of Cañon Diablo, M. Mallard, 575
- Armstrong (H. E., F.R.S.) : Sulphochloride of Isomeric Dibromonaphthalenes, 263; Action of Alcohol on Sulphonic Chloride, a Means of producing Etheral Salts of Sulphonic Acid, 263; Action of Bromine on Mixture of Ortho- and Parantiro-*a*-Acenaphthalides, 263; Camphrene, 263; the Interactions occurring in Flames, 430; Relative Orienting
- Effect of Chlorine and Bromine, the Constitution of Parabrom- and Parachloraniline Sulphonic Acids, 525; Anhydrides of Sulphonic Acids, 525; Production of Ketone 1 : 2 : 4-Acetoxyhexylene from Camphor by Action of Sulphuric Acid and Zinc Chloride, 551
- Arons (Dr.), Experiments on the Electrical Polarization at the Two Sides of a Metallic Plate Immersed in an Electrolyte at Right Angles to the Current, 576
- Arrow Poison, A. Coppen Jones, 343
- Art, on the Relation of Natural Science to, Prof. E. du Bois Reymond, F.R.S., 200, 224; W. Ainslie Hollis, 319
- Arteries, a Treatise on the Ligation of the Great, in Continuity, with Observations on the Nature, Progress and Treatment of Aneurism, Chas. A. Ballance and Walter Edmunds, Dr. M. Armand Ruffer, 530
- Artillery of the Future and the New Powders, James Atkinson Longridge, 146
- Asia, Central, M. Grum-Grzimalo's Journey to, 40
- Askenasy (Herr), Silent Combination of Hydrogen and Oxygen, 616
- Ass, the Cat and the Sheep in China, the Origin of the, Dr Macgowan, 285
- Assheton (R.), the Formation and Fate of the Primitive Streak in the Frog, 140
- Assimilation of Diet investigated in a Dog working in a Tread mill, Dr. Rosenberg, 599
- Assmann (Dr.), Meteorological Observations during Balloon Voyages, 168
- Assmann (Dr.), Observations made in a Captive Balloon, 432
- Aston (Emily), some Compounds of Oxides of Silver and Lead, 93
- Astronomy : T. W. Backhouse on the Apparent Size of Objects near the Horizon, 7; Proper Motions of the Stars, W. H. S. Monck, 8; Dr. Müller on the Telluric Spectrum, 21; Tempel-Swift's Periodic Comet, 21; Catalogue of Rutherford's Photographs, 21; Our Astronomical Column, 21, 41, 68, 89, 117, 137, 159, 186, 210, 237, 261, 280, 307, 325, 352, 380, 404, 422, 446, 473, 497, 521, 547, 569, 589, 616; Outburst of Dark Spots on Jupiter, 42; Wolf's Periodic Comet, 42; the Total Lunar Eclipse of November 15, 42; the Elements of the Minor Planets, 42; Star Groups, J. Ellard Gore, 52; Theory of Astronomical Aberration, M. Mascart, 68; Two New Laws of Celestial Mechanics, H. Struve, 70; the Rotation of Jupiter, A. Belopolsky, 70; Determination of the Solar Parallax, A. Auwers, 89; Photometric Observations, Dr. Müller, 90; Tables of *Vesta*, G. Leveau, 95; Method of observing the Motion of Stars in the Line of Sight, Prof. J. Norman Lockyer, F.R.S., 117; the Variation of Latitude, 117; Photography of the Eclipsed Moon, 117; the Recent (December 1, 1891) Eclipse of the Moon, Mrs. R. M. Crawshaw, 134; Proposals for a Co-operative Observation of the so-called Luminous Clouds, 117; Prof. J. S. Slater's Improved Armillary Sphere, 134; the Secular Acceleration of the Moon, and the Length of the Sidereal Day, 137; State of Solar Activity, Prof. Tacchini, 137; Observations of  $\mu$  Cephei, J. E. Gore, 137; Influence of Ring and Disk Blinds in Micrometric Measurements, Dr. Walter Wislicenus, 137; Annals of the University Observatory in Vienna, 138; Astronomische Nachrichten 3068, 3069, 159; Jupiter and his First Satellite, E. E. Barnard, 159; Spectra of the Sun and Metals, F. McClean, 159; Tempel-Swift Comet, 159; Distribution of Energy in Stellar Spectra, Prof. Pickering, 159; on the Observation of North Polar Stars in the Vertical of Polaris, 159; Measurement of Jupiter's Satellites by Interference, A. A. Newton, 160; Capture of Comets by Planets, Prof. H. A. Newton, 186; Law of Limiting Apertures, Dr. E. J. Spitta, 186; Connaissance des Temps, 186; Secular Variation of Latitudes, 210; Rotation of Venus, Herr Loschardt, 210; Stars having Peculiar Spectra, Prof. Pickering, 210; a Double Moon, Rose Mary Crawshaw, 224; Wolf's Periodic Comet, Dr. Berberich, 237; the Diffraction Effects produced by placing Screens in Front of Object Glasses, Prof. Pritchard, 237; Refractive Power of Cometary Matter, E. E. Barnard, 237; Himmel und Erde, 237; Washington Observations, 1886, 237; Stonyhurst Drawings of Sun-spots and Faculae, Rev. Walter Sidgreaves, 261; some apparently Variable Nebulae, Lewis Swift, 261; the Red Spots on Jupiter, W. F. Denning, 272; Motion of Stars in the Line of Sight, Prof. H. C. Vogel, 280; Orthochromatic Plates for Astronomical Photography, MM. Fabre and Andoyer, 281;

- the Astronomical Theory of the Glacial Period, Sir Robert Ball, Prof. G. H. Darwin, F.R.S., 289; on some Points in Ancient Egyptian Astronomy, J. Norman Lockyer, F.R.S., 296, 373; Obituary Notice of Prof. John Couch Adams, 301; Proposed National Monument to late Prof. J. C. Adams, 401; Election of Sir R. S. Ball to Lowndes Professorship in room of late Prof. Adams, 402; Wolf's Numbers for 1891, 307; Solar Activity in 1891, Rudolf Wolf, 307; a New Journal, 307; Large Meteor of January 24, 1892, W. F. Denning, 317; New Star in the Milky Way, Ralph Copeland, 325; Observations of Mars, Dr. Lohse, 326; Solar Prominence Photography, Prof. G. E. Hale, 326; Re-discovery of Brooks's Comet (1890 II.), 326; the Vacant Chair of Astronomy at Cambridge, 337; on the New Star in Auriga, 344, 366; Thos. D. Anderson, 365; G. Rayet, 408; J. Norman Lockyer, F.R.S., 429; the Astronomer-Royal for Scotland, 454, 527; H. C. Vogel, 498; Report of U.S. Naval Observatory, 352; Observations of Nebulae and Star Clusters, M. Bigourdan, 352; Solar Observations, Prof. Tacchini, M. Marchand, 352; Measures of the Nebula near Herpe, 352; Photographic Magnitudes of Stars, 380; Zodiacal Light, O. T. Sherman, 381; a Preliminary Statement of an Investigation of the Dates of some of the Greek Temples as derived from their Orientation, F. C. Penrose, 395; Solar Disturbances of 1891, June 17, H. H. Turner, 404; Photography of Solar Prominences, M. Deslandres, 404; on the Variation of Latitude, Dr. S. C. Chandler, 404; the Warner Observatory, 422; Measurement of Solar Prominences, M. Fizeau, 422; the Draper Catalogue of Stellar Spectra, A. Fowler, 426; Cordova Observatory, 446; Algol, Dr. S. C. Chandler, 446; Sun-spots of February, 446; a New Comet, Prof. Lewis Swift, 446; Prof. Krueger on Motions of Periodic Comets, 446; Orientation of Ancient Monuments, Rev. Fred. F. Grensted, 464; Solar Investigations, Prof. Hale, 473; New Double Star, 26 Aurigæ, S. W. Burnham, 473; Rotation of Jupiter, W. F. Denning, 473; New Star in Auriga, Herrn Eugen and Gothard, J. Norman Lockyer, F.R.S., 473; the Lick Spectroscope, 473; a Bright Comet, 473; Sun Pillar, Annie Ley, 484; New Comet, W. F. Denning, 484; Fuzziness of some Variable Stars, Cuthbert G. Peck, 497; Astronomical Possibilities at Considerable Altitude, Prof. Pickering, 498; Increase of the Earth's Shadow during Lunar Eclipses, Dr. Hartmann, 498; Aberration, Lord Rayleigh, Sec.R.S., 499; a New Comet, W. F. Denning, 513; the Planet Jupiter, 521; the Objective Prism, Prof. Pickering, 521; Variation of Latitude, Dr. B. A. Gould, 521; the Discovery of Neptune, Prof. Holden, 522; Astronomy at the Paris Academy, March 21, 522; Variability of Nebulae, Dr. Lewis Swift, 522; Solar Prominence Photography, M. Deslandres, 522; Aurora Spectrum, Prof. Hale, 522; the Capture of Lexell's Comet by Jupiter, Prof. G. H. Darwin, 526; the Relative Motion of 61 Cygni, Prof. A. Hall, 547; the Temperature of the Sun, M. H. Le Chatelier, 547; Comet Swift, March 6, 548; Wolf's Comet, 1891 II., Herr Dr. Thraen, 548; Periodic Perturbations of the Four Inner Planets, Prof. Newcomb, 548; N.P.C.'s observed with Greenwich and Washington Transit Circles, Prof. Newcomb, 548; Washington Observations, 1887, 548; Observations of the Spectrum of Nova Aurigæ, Dr. Henry Crew, 569; E. W. Maunder, 616; Denning's Comet (2 1892); Dr. R. Schorr, 569; Comet Swift, 1892, 569; Displacement of Radiant Points, Dr. J. Kleiber, 570; Two New Variables in Cepheus, Paul S. Vendell, 570; on the Variation in Latitude, M. Faye, 570; Elementary Mathematical Astronomy, C. W. C. Barlow and G. H. Bryan, 579; Astronomy at the Paris Academy, April 11, M.M. Périgaud and Boquet, 589; Solar Heat, Dr. Joseph Morrison, 589; Periodic Variations in Latitude, — Chandler, 589; Perseids observed in Russia in 1890, Th. Breichin, 597; Photography at the Cape Observatory, D. Gill, 600; Photographs of the Region of Nova Cygni, 617; Winnecke's Comet, Dr. G. F. Haerdtl, 617; Personal Equations in Transit Observations, 617; the Sirius System, Dr. A. Auwers, 617; Photographs of a part of Cygnus, M. Faye, 624
- Atlantic, North, Severe Weather in the, October 1891, 38  
 Atlantic, North, Pilot Chart of, December 1891, 258  
 Atlas, the Dwarfs of Mount, R. G. Haliburton, 66  
 Atlas, Handy, of Modern Geography, 605  
 Atlas, the Universal, 52  
 Atlatl, the Mexican, 66, 102
- Atmosphere, the Mass of the, M. Mascart, 311  
 Atmosphere, Polarization of, by Light of Moon, N. Piltshchikoff, 456  
 Atmosphere, the General Circulation of the, Dr. J. M. Pernter, 593  
 Atmospheric Pressure, Physiological Action of Diminished, F. R. Mallet, 606  
 Atmospheric Rings, Dr. Sprung, 599  
 Attitudes of the Zebra during Sleep, and their Influence on the Protective Value of its Stripes, on the, 248  
 Aubin (Percy A.), the Limpet's Power of Adhesion, 464  
 Auriga, on the New Star in, 344, 366; Thos. D. Anderson, 365; G. Rayet, 408; J. Norman Lockyer, F.R.S., 429; Astronomer-Royal for Scotland, 454, 527; S. W. Burnham, 473; H. C. Vogel, 498  
 Auroras: a Rare Phenomenon seen at Lyons, N.Y., Dr. M. A. Veeder, 7; at Halifax, Prof. J. G. MacGregor, 7; at Toronto, R. N. Hudspeth, 7; Plan for Observations to determine Local Distribution and Altitude of, M. A. Veeder, 234; Aurora, Geo. M. Seabroke, 605; Arthur Marshall, 605; Arthur E. Brown, 605; Aurora visible from Westgate-on-Sea, 613; Aurora Borealis, J. Lovel, 223; Aurora Borealis in America, Remarkable Display of, 378; the Aurora Spectrum, Prof. Hale, 522  
 Australia: Hydrology of the Mitta Mitta, James Stirling, 40; Botanical Museums and Gardens of Australasia, Prof. Goodale, 65; a New Freshwater Isopod, Charles Chilton, 66; Olive-Culture in Australia, J. L. Thomson, 135; Horticulture in South Australia, 184. Australasian Association for the Advancement of Science: Section A, Mathematics, Physics, and Mechanics—Mathematical Analogies between various Branches of Physics, Prof. Bragg, 423; Seismological Phenomena in Australasia, 423; Quaternions as a Practical Instrument of Physical Research, A. McAuley, 423; the Grouping of Stars in the Southern Part of the Milky Way, H. C. Russell, F.R.S., 423. Section B, Chemistry and Mineralogy—W. M. Hamlet on the Progress of Chemistry in Australasia, 423; A. Livessidge, F.R.S., on the Rusting of Iron, 424. Section C, Geology and Palæontology—T. W. E. David on Volcanic Action in Eastern Australia and Tasmania, 424; W. J. C. Ross on the Discovery of Two Specimens of Fossil Lepidodendrons in the Neighbourhood of Bathurst, New South Wales, and the Inferences to be drawn from their Occurrence, 424. Section D, Biology—Prof. W. Baldwin Spencer on the Freshwater and Terrestrial Fauna of Tasmania, 425; Prof. Hutton on the Origin of the Struthious Birds of Australasia, 425; Prof. Spencer on the Habits of Ceratodus, the Lung Fish of Queensland, 425. Section E, Geography—Captain Pasco on Early Discoveries in Australia, 425; D. Murray on Mr. Lindsay's Expedition in Western Australia, 425; J. P. Thomson on Recent Explorations and Discoveries in British New Guinea, 425. Section F, Economics and Social Science and Statistics, 426. Section G, Anthropology—Rev. Lorimer Fison on Anthropological Study, 426. Section H, Sanitary Science and Hygiene, 426. Section I, Literature and Fine Arts—Prof. Morris on Universities in Australia, 426. Section J, Engineering and Architecture—C. Napier Bell on Sanitary Engineering, 426  
 Austria, Health Springs of Germany and, Dr. F. O. Buckland, 510  
 Austria-Hungary, the Increase of Population in, 158  
 Austrian Economists, W. Smart, 268  
 Auwers (A.): Determination of the Solar Parallax, 89; the Sirius System, 617  
 Aylesbury, Proposed County Museum for Bucks, 114  
 Aymonnet (M.), Periodic Heat Maxima observed in Spectra from Flint and Crown Glass, and Rock Salt, 504  
 Ayrton (Prof. W. E., F.R.S.): the Thermal Emissivity of Thin Wires in Air, 162; Rotary Currents, 191; Electrotechnics, 326; the Function of a University, 439  
 Azaleas, Intermediate Forms of, Wm. Sowerby, 519  
 Azoimide, N<sub>3</sub>H, Further Researches upon, A. E. Tutton, 127
- Babel, the Tower of, and the Confusion of Tongues, Thos. G. Pinches, 210  
 Bacillus in Influenza, the Alleged Discovery of a, 250  
 Backhouse (T. W.): Apparent Size of Objects near the Horizon, 7; Nacreous Clouds, 365  
 Bacterium allii, Dr. Griffiths, 624  
 Bagard (H.), a Thermo-electric Standard of Electromotive Force, 192

- Bahama Islands : Sponge Trade of the, 20 ; Telegraphic Connection with, 114
- Bailey (E. H. S.), Tonganoxie Meteorite, 119
- Bailey (G. H.), Superheated Steam, 414
- Baird (Mr. Spencer F.), Death of, 278
- Bakhuus Roozeboom (Dr.), Influence of Isomorphism on Behaviour of Double Salt, during Solution, 240
- Balansa (B.), Death and Obituary Notice of, 349
- Ball (Sir Robert, F.R.S.), the Cause of an Ice Age, 365 ; Prof. G. H. Darwin, F.R.S., 289 ; Henry H. Worth, 440 ; Election of, to succeed the late Prof. Adams in the Lowndes Professorship of Astronomy at Cambridge, 402
- Ball (Dr. Valentine, F.R.S.), the Koh-i-Nur, 126
- Ballance (Chas. A.), a Treatise on the Ligation of the Great Arteries in Continuity, with Observations on the Nature, Progress, and Treatment of Aneurism, Dr. M. Armand Ruffer, 530
- Ballistics : Calculation of Trajectories of Elongated Projectiles, Rev. F. Bashforth, 473
- Balloon Voyage for Scientific Purposes, the First, Prof. Hellmann, 471
- Balloon Voyages, Meteorological Observations during, Dr. Assmann, 168
- Barclay (Dr. A.), Rain and Mildews in India, 477
- Barlow (C. W. C.), Elementary Mathematical Astronomy, 579
- Barnard (E. E.) : Jupiter and his First Satellite, 159 ; Refractive Power of Cometary Matter, 237
- Barometer, How to use the Aneroid, Edward Wympy, 339
- Barometrical Depression (Nov. 11, 1892), Phenomenal, G. J. Symons, 65
- Barrett-Hamilton (G. E. H.), Harrow Birds, 342
- Barus (Carl) : the Solution of Vulcanized India-rubber, 118 ; Relation of Melting-point to Pressure in Igneous Rock Fusion, 311
- Bashforth (Rev. F.), Calculation of Trajectories of Elongated Projectiles, 473
- Basses Pyrénées, Extermination of the Wild Daffodil in the, 545
- Basset (A. B., F.R.S.) : on Selective and Metallic Reflection, 119 ; on the Theory of Elastic Wires, 215 ; Phonomy, 486
- Batavian Society of Arts and Sciences, 38
- Bates (H. W., F.R.S.) : Death of, 377 ; Obituary Notice of, 398
- Bateson (W.), Variations in the Colour of Cocosons, 143
- Bats flying in the Daytime, R. Haig Thomas, 8
- Batten (E. H. M.), the Opium Question, 545
- Batters (E. A. L.), a New Marine Alga, *Gonimophyllum Buffhami*, 596
- Baumann (Prof. Oscar), Projected East African Expedition, 65
- Bausch (Edward), Manipulation of the Microscope, 342
- Beaches, Formation of, Signor P. Cornaglia, 362
- Beaches, the Formation and Erosion of, 412
- Beast and Man in India, John Lockwood Kipling, 131
- Beddard (Frank E.) : Formation of a Temporary Cyst in the Fresh-water Annelid *Aelosoma*, 28 ; Warning Colours, 78 ; Preliminary Notice of a New Branchiate Oligocheate, 109
- Bedford College and the Gresham University, Dr. W. J. Russell, F.R.S., Lucy J. Russell, 391
- Beeby (W. H.), Grafted Plants, 151
- Behrens (Mr.), Microscopic Structure of Hard Steel, 48
- Bell (Alex. Graham), a Rare Phenomenon, 79
- Bell (C. Napier), on Sanitary Engineering, 426
- Bell (Dugald), the Alleged Submergence in Scotland during the Glacial Epoch, 527
- Bell (Prof. F. Jeffrey), on the Echinoderms collected during the Fishing Survey on the West Coast of Ireland, 598
- Belopolsky (A.), the Rotation of Jupiter, 70
- Bemmelen (Heer van), the Difference of Colloid Oxides and Crystalline Hydrates, 576
- Ben Nevis, Dust-Counting on, Angus Rankin, 582
- Benham (Dr. W. B.), the Nephridium of Lumbricus and its Blood-Supply, 140
- Bennett (Alfred W.) : Inheritance of Acquired Characters, 53 ; Alleged Pseudopods of Diatoms, 177
- Bent (Theodore) : the Zimbabwe Ruins, 402 ; Finds at the Great Zimbabwe Ruins, 551
- Berberich (Dr.), Wolf's Periodic Comet, 237
- Berg (E.), Frequency and Geographical Distribution of Heavy Daily Rainfall, 258
- Berlin : Prof. Pictet's Laboratory at, Prof. R. du Bois-Reymond, 31 ; Berlin Physical Society, 48, 96, 168, 240, 312, 432, 456, 576 ; Berlin Physiological Society, 48, 95, 168, 240, 312, 432, 456, 576, 599 ; Berlin Meteorological Society, 95, 168, 312, 432, 576 ; Rainfall and Thunderstorms of, 114
- Bernard (H.), a New Form of Mechanical Stage for Microscopical Work, 239
- Bernays (Dr. A. J.), Death of, 258
- Berthelot (D.) : Existence of Acid or Basic Salts of Monobasic Acids in very Dilute Solutions, 72 ; Heat of Formation of Hydrazine and Hydracetic Acid, 95 ; the Three Basicities of Phosphoric Acid, 192 ; the Spontaneous Oxidation of Humic Acid and Vegetable Soil, 288 ; a Method of Organic Analysis, 408
- Besant (Dr. W. H., F.R.S.), Phonomy, 462
- Besson (M.) : Phosphides of Boron, 136 ; the Bromine Derivation of Methyl Chloride, 143 ; Two New Compounds of Carbon, Chlorine, and Bromine, 351 ; a Silicon Chlorosulphide, 240
- Bienfait (Dr. Alfred) and the Physiology of Respiratory Centres, 624
- Biese (Dr. E.), Meteorology of Finland, 87
- Bigourdan (M.), Observations of Nebulæ and Star Clusters, 352
- Binnie (W. J. E.), Electric Self-recording Rain-Gauge, 95
- Biology : of Seaside Plants, W. Botting Hemsley, F.R.S., 3 ; Suggestions for Securing Greater Uniformity of Nomenclature in Biology, Prof. T. Jeffery Parker, F.R.S., 68 ; Preliminary Notice of a New Branchiate Oligocheate, Frank E. Beddard, 109 ; the Marine Biological Association, 116 ; Discoloration of Water by Minute Marine Organisms in Port Jackson, Sydney, 184 ; Proposed Columbus Station at Jamaica, 401 ; Prof. Ray Lankester, 450 ; Wandering Cells in Echinoderms, &c., H. E. Durham, 420 ; the Excretory Processes in Marine Polyzoa, S. F. Harmer, 450 ; on *Onchesoma steenstrupii*, A. E. Shipley, 450 ; Note on a Sieve-like Membrane across Oscula of a Species of Leucosolenia, E. A. Minchin, 450 ; the Nauplius Eye persisting in some Decapods, Margaret Robinson, 450 ; a New Genus of Synascidians from Japan, Oka and Willey, 450 ; Anatomy and Habits of Alcyonium, S. J. Hickson, 455 ; Appointment of Mr. George Brebner as first Marshall Scholar, 183 ; Evolution of Life, or Cause of Change in Animal Forms, Hubbard Winslow Mitchell, 364 ; the Limpet's Power of Adhesion, Percy A. Aubin, 404 ; the Limpet's Strength, J. Lawrence Hamilton, 487 ; Biology of the Sunflower, A. Godygynoff, 597 ; Prof. A. Chauveau elected President of the Société de Biologie, 612
- Bird Gallery in the British Museum, 154
- Birds, Extinct, on a Recent Discovery of the Remains of, in New Zealand, Prof. Henry O. Forbes, 416
- Birds, Fossil, Catalogue of, in the British Museum, Richard Lydekker, 33
- Birds, Harrow, G. E. H. Barrett-Hamilton, 342
- Birds, Intelligence in, A. Wilkins, 151, 177
- Birds, Migratory, passing over Dublin, 20
- Birds, Struthious, of Australasia, on the Origin of the, Prof. Hutton, 425
- Birds in Victoria, the Protection of, Baron von Mueller, 280
- Birkinbine (John), Production of Pig Iron in United States, 208
- Bishop (Mrs.), Journeys in Persia and Kurdistan, 248
- Blackie (Prof.), on the Most Recent Phases of Greek Literary Style, 624
- Blake (J. F.), Annals of British Geology, 1890, 77
- Blakesley (Thos. H.), a Possible Misunderstanding, 441
- Bianford (Henry F., F.R.S.), Winter Storms of Northern India, 490
- Bleicher (M.), Microscopic Structure of Oolitic Iron from Lorraine, 504
- Blindness, Colour, and Colour Perception, F. W. Edridge Green, 195
- Blondlot (R.) Experimental Determination of Velocity of Propagation of Electro-magnetic Waves, 72 ; Influence on Electro-magnetic Resonance of Unsymmetrical Arrangement of Propagation Circuit, 408
- Blood, Influence of Leucocytes on the Clotting of, Dr. L. Lilienfeld, 599
- Blowpipe Analysis, J. Landauer, 580
- Blue Hill Meteorological Observatory, 418
- Boerlage (Dr. J. G.), Handleiding tot de Kennis der Flora van Nederlandsch Indie, 28
- Boernstein (Prof.), Extraordinarily Rapid Evaporation on Glacier, 312
- Boilers, Modern Lancashire, Samuel Boswell, 22

- Bois-Reymond (Prof. R. du), Prof. Pictet's Laboratory at Berlin, 31
- Boisboudran (Lecoq de): Researches on Samarium, 504; the Spark Spectra of Gallium, 575
- Bollettino della Società Botanica Italiana, 478
- Boltzmann-Maxwell Law of Partition of Kinetic Energy, on the, Rev. H. W. Watson, F.R.S., 512
- Bombay Natural History Society, Account of the Taming of a Heron, 588
- Bonaparte's (Prince Louis Lucien), Collection of Metals, 348
- Bonaparte (Prince Roland), Measures of Variations in Lengths of Dauphiny Glaciers, 576
- Bonavia (E.), Philosophical Notes on Botanical Subjects, 483
- Bonney (Prof. T. G., F.R.S.): With Axe and Rope in the New Zealand Alps, George Edward Manning, 147; Note on Specimens of Rock Exposed to High Temperature, 357; the Hornblende Schists, Gneisses, and other Crystalline Rocks of Sark, 359; Cirques, 391; Travels among the Great Andes of the Equator, Edward Whymer, 561; the Year-book of Science, 1891, 604
- Bonnier (Dr. G.), the Relation of the Mistletoe to its Parent Tree, 421
- Bonvalot (Gabriel), Across Tibet, 269
- Books, Forthcoming Scientific, 476
- Boquet (M.), Astronomy at the Paris Academy, April 11, 589
- Borkovsky (M.), the Grain Production of Russia, 67
- Boston, Fossils Recently Discovered near, Warren Upham, 622
- Boswell (Samuel), Modern Lancashire Boilers, 22
- Botany: Biology of Seaside Plants, W. Botting Hemsley, F.R.S., 3; Botany of the Emin Relief Expedition, W. T. Thiselton Dyer, F.R.S., 8; Major J. A. M. Jephson, 9; Handledning tot de Kennis der Flora van Nederlands Indie, Dr. J. G. Boerlage, 28; B. Daydon Jackson's Index of Genera and Species of Flowering Plants, 39; Wild Maize found in Mexico, 39; Government Mission to Investigate the Botany of Sierra Leone, 64; Botanical Museums and Gardens of Southern Hemisphere, Prof. Goodale, 65; the Acclimatization of the Avocado Pear in New South Wales, F. Turner, 66; Botanical Gazette, 70, 287, 478, 596; Third Series of Hooker's Icones Plantarum, 86; Pupils at the Missouri Botanical Gardens, 88; Disease among the Cocoa-nuts of Jamaica, 88; Zoology and Botany of the West Indian Islands, 139; Grafted Plants, W. K. Beeby, 151; Current Botanical Expeditions, 155; Insectivorous Plants, R. Lindsay, 157; the Prolongation of the Gooseberry Season, D. Thomson, 157; Revisio Genera Plantarum Vasculares Omnium, atque Cellularium Multarum, secundum Leges Nomenclaturæ Internationales, cum enumeratione Plantarum in Itinere Mundi Collectarum, Dr. Otto Kuntze, W. Botting Hemsley, F.R.S., 169; Some Peculiar Changes in Colour of Flower of *Suaiversonia procumbens*, J. P. Eckert, 185; the Ginger-beer Plant, Prof. H. M. Ward, F.R.S., 190; Parasitic Fungi in Fodder, F. Turner, 236; Chinese Fibres, 278; the Flora of the River Gambia, Dr. Brown Lester's Collection, 278; List of Staff of Kew and Corresponding Colonial Establishments, 278; Obituary Notice of Walter Hood Fitch, 302; Chloride of Sodium in Plants, P. Lesage, 312; the Kew Bulletin, 323, 402, 586; Proposed Discontinuance of the Kew Bulletin, 494; Jubilee of Kew Gardens, 378; Herr J. Bornmüller's Botanical Expedition, 378; Caoutchouc-containing Cells of *Eucommia ulmoides*, F. E. Weiss, 335; the Genus *Dianthus*, F. N. Williams, 383; Grasses of the South-West, Dr. George Vasey, 390; Sisal Hemp, 402; Ripse Seeds of the Monkey-Puzzle Tree (*Araucaria imbricata*) of Chili, grown in England, Dr. R. C. A. Prior, 421; the Relation of the Mistletoe to its Parent Tree, Dr. G. Bonnier, 421; a New West Indian Form of *Agave rigida*, J. H. Hart, 445; Method of Fertilization in *Ixora*, J. C. Williams, 455; the Pollen-tube of Gymnosperms, Herr W. Belajeff, 471; Rain and Mildews in India, Dr. A. Barclay, 477; a New Capillary Theory, F. Pasquale, 478; Earthquakes and Vegetation, A. Goiran, 478; the Relationship of Autumn- to Spring-Blossoming Plants, A. F. Foerste, 478; the Effect of Mechanical Movement on the Growth of Certain Plants, H. L. Russell, 478; Movements of the Flower and Fruit of *Erodium gruinum*, Dr. R. Cobelli, 478; Philosophical Notes on Botanical Subjects, E. Bonavia, 483; Award by Royal Society of New South Wales of Clarke Memorial Medal to Mr. W. T. Thiselton Dyer, 495; the Spanish Broom as a Fibre Plant, 495; Uganda Bark Cloth, 495; New Papuan Plants, Diagnoses of, Baron v. Mueller, 496; the Oak, a Popular Introduction to Forest Botany, H. Marshall Ward, F.R.S., 509; Intermediate Forms of Azaleas, Mr. William Sowerby, 519; Effects of Earthquakes on Vegetation, Signor Goiran, 520; Influence of Electricity on Growth of Plants, Prof. Aloï, 520; a New Seaweed from Cape Colony (*Phaeocarpus disciger*), 526; Extinction of the Wild Daffodil in the Basses Pyrénées, 595; Botanical International Congress to be held at Genoa in connection with Celebration of Quatercentenary of Discovery of America by Columbus, 545; Remarkable Development of Botanical Establishment of Harvard University by Munificence of Prof. G. L. Goodale, 545; the Ants attracted by *Cynips calycis* Galls, a Protection to *Quercus pedunculata*, Dr. Ráthay, 546; a New Theory of the Morphology of the Carpel in Flowering Plants, F. Pasquale, 546; Dr. J. T. Rothrock on the Flora, &c., of the Bahamas and Jamaica, the Mangrove as a Source of Tannin, 546; Fertilization of the Casuarinaceæ, 548; Seis of Exsiccate Coccidæ to be issued by the Institute of Jamaica, 567; Panax Gum, J. H. Maiden, 567; Sunflower Cultivation in Southern Russia, 568; Biology of the Sunflower, A. Gordyaghin, 597; J. Caruthers appointed Lecturer in Botany at the College of Agriculture, Downton, 586; Lectures on Systematic Botany at St. Thomas's Hospital, 586; Evolution in Methods of Pollination, Miss Alice Carter, 596; on the Phenomena concerned in the Production of Forked and Branched Palms, D. Morris, 598; Our Trees, John Robinson, 603
- Bothamley (C. H.): the Ilford Manual of Photography, 460; the Optical Lantern as an Aid in Teaching, 437
- Botocudos of Brazil, the, 615
- Boulenger (G. A.), Zoological Reports, 104
- Bourne (Dr. A. G.), *Pelomyxa viridis*, 140
- Bow as Origin of Stringed Instruments, the, Dr. E. B. Tylor, F.R.S., 184
- Bowman (Sir William, F.R.S.): Death of, 517; Obituary Notice of, Prof. J. Burdon Sanderson, F.R.S., 564
- Bower (Capt.), Journey from China to Simla, 615
- Bragg (Prof.), Mathematical Analogies between various Branches of Physics, 423
- Brain, the Intracranial Circulation and its Relation to the Physiology of the, James Cappie, M.D., 26
- Branchiata Oligochaeta, Preliminary Notice of a New, Frank E. Beppard, 109
- Brazil: Dismissal of Dr. Fritz Müller, 156; the Mineral Wealth of, 235; the Botocudos of, 615
- Brebner (Mr. George), Appointment as first Marshall Scholar in Biology of, 183
- Brewing, the Science of, E. R. Moritz and G. H. Morris, 100
- Briggs (J. F.), Relative Orienting Effect of Chlorine and Bromine, 525
- Briggs (W.), Synopsis of Non-Metallic Chemistry, 604
- British Art, Science Museum and Gallery of, at South Kensington, 348
- British Association, Arrangements for Edinburgh Meeting, 401
- British Columbia, the Salmon Industry in, 279
- British Earthworm, a Rare, Rev. Hilderic Friend, 365
- British Edible Fungi, how to Distinguish and how to Cook the m, M. C. Cooke, 75
- British Flies (Diptera), an Account of, Hon. M. Cordelia E. Leigh and F. V. Theobald, 173
- British Fungi, Phycomyetes and Ustilagineæ, G. Masee, 411
- British Geology, 1890, Annals of, J. F. Blake, 77
- British Guiana, Proposed Establishment of an Agricultural College in, 520
- British Isles, Volcanic Action in the, Sir Archibald Geikie, F.R.S., 398
- British Museum: Catalogue of Fossil Birds in, Richard Lydekker, 33; Bird Gallery in the, 154; Mr. A. S. Woodward appointed Assistant-Keeper of the Department of Geology, 566
- Broads, how to Organize a Cruise on the, E. R. Suffling, 52
- Brochet (A.), Pyrogenous Hydrocarbons formed in Gas Industry, 504
- Brodie (F. J.), the Prevalence of Fog in London, 1871-90, 215
- Bronze Age in the East and Southern Europe, the, Prof. Montelius, 39
- Bronze in the London Atmosphere, Prof. Roberts-Austen, 443
- Brooks's Comet (1890 II.), Rediscovery of, 326
- Brown (Prof. A. Crum, F.R.S.), Rule for Determining whether a given Benzene Mono-derivative shall give a Meta-derivative or a Mixture of Ortho- and Para-derivatives, 525

- Brown (Arthur E.), Aurora, 605  
 Brown (A. J.), the Influence of Oxygen and Concentration on Fermentation, 453  
 Brown (H. T.), Search for a Cellulose-dissolving Enzyme in Digestive Tract of certain Grain-feeding Animals, 452  
 Brown (J. A.), the Continuity of the Palaeolithic and Neolithic Periods, 503  
 Browne (R. G. Mackley), the Precipitation and Deposition of Sea-borne Sediment, 598  
 Bruce (E. S.), an Aërial Graphoscope for Showing Effects of Persistence of Vision, 574  
 Brücke (Dr. Ernst von), Death of, 303  
 Brugsch-Bey (H.), Egypt under the Pharaohs, 363  
 Brun (E.), Combinations of Cuprous Iodide with Ammonium Thiosulphate, 528  
 Brussels Academy of Sciences, 216, 624  
 Bruyn (Dr. de), a New Hydroxylamine, 48  
 Bryan (G. H.), Elementary Mathematical Astronomy, 579  
 Buchanan (Dr. George), Knighted, 544  
 Buckinghamshire, Proposed County Museum for, 114  
 Buckland (Dr. F. O.), Health Springs of Germany and Austria, 510  
 Buda Peth, Natural History Society of, 471  
 Budde (Dr.), Experiments on the Inert Layer in Emulsions of Chloroform and Soda, 599  
 Building and Decoration, Stones for, Geo. P. Merrill, 222  
 Bulletin de l'Académie des Sciences de St. Pétersbourg, 79, 597  
 Bulletin de la Société des Naturalistes de Moscou, 141  
 Bulletin of the New York Mathematical Society, 597  
 Bunsen (Prof.) and the Chemical Society, 469  
 Burbury (S. H., F.R.S.), Prof. Burnside's Paper on the Partition of Energy, 533  
 Burial Mound in Florida, Opening of, C. B. Moore, 567  
 Burnham (S. W.), New Double Star, 26 Aurigæ, 473  
 Burnside's (Prof.) Paper on the Partition of Energy, R.S.E., July 1887, Prof. W. Burnside, S. H. Burbury, F.R.S., 533  
 Burton (Dr. C. V.), a New Theory concerning the Constitution of Matter, 142  
 Butler (G. W.): the October Eruption North-West of Pantelleria, 154; on the Matter thrown up during the Submarine Eruption North-West of Pantelleria, October 1891, 251; Abstract of Mr. A. Ricco's Account of the Submarine Eruption North-West of Pantelleria, October 1891, 584  
 Butterflies, Pigment in Yellow, F. Gowland Hopkins, 197  
 Buvé (Abbé), the Quantity of Sugar produced in Various Plants as a Means of determining the Meteorological Elements concerned, 279  
 C.G.S. System of Units, O. H. Tittmann, 581; Prof. J. D. Everett, F.R.S., 581  
 Cabinet-Making, the Art and Craft of, D. Denning, 459  
 Caddis-fly, Abbreviated Wings of the Male, R. McLachlan, F.R.S., 623  
 Calculations, Chemical, R. Lloyd Whiteley, 604  
 Calculus, an Introduction to the Differential and Integral, T. Hugh Miller, 52  
 Calcutta, Catalogue of Mammalia in the Indian Museum, W. L. Sclater, 50  
 California, Earthquake in, 471  
 California Foxes, Prof. Edward S. Holden, 8  
 California, Severe Earthquake in, 614  
 Call (R. Ellsworth), the Tertiary Silicified Woods of Eastern Arkansas, 119  
 Callender (H. L.), a Compensating Air-Thermometer, 212  
 Calvert (Albert F.), Ornithology of the Sandwich Islands, 485, 558  
 Camargue, Reclaiming and Cultivation of Land in the, M. Chambréant, 143  
 Cambridge: Cambridge Philosophical Society, 47, 143, 166, 455, 526; Cambridge Philosophical Society and the late Prof. Adams, the, 322; Election of the Duke of Devonshire to Chancellorship, 233; Preliminary Installation of the Duke of Devonshire as Chancellor of Cambridge University, 257; the Vacant Chair of Astronomy at, 337; Election of Sir R. S. Ball to succeed late Prof. Adams in Lowndes Professorship, 402  
 Camel, Herr Lehmann on the, 87  
 Camera Lucida Measurements, Apparatus for making Accurate, Sir W. J. Sendall, 46  
 Campbell (A. J.), Nest and Egg of Bird of Paradise, 379  
 Campbell (Charles W.), Korea, 307  
 Canada, Aborigines of the Dominion, Hon. E. Dewdney, 587  
 Canal between New York and Philadelphia, Proposed Ship, Prof. L. M. Haupt, 497  
 Canals of Arizona, the Prehistoric Irrigation, 186  
 Cannizzaro (Prof. Stanislao): Royal Society Medallist, 111; Banquet to, 183  
 Cap Horn, Mission Scientifique de, J. Deniker and P. Hyades, 577  
 Cape Colony, Dr. Thomas Muir appointed Superintendent-General of Education for, 443  
 Cape Observatory, Topography at the, D. Gill, 600  
 Cape of Good Hope, *Vedalia cardinalis* successfully Colonized at the, 615  
 Cappie (James, M.D.), the Intracranial Circulation and its Relation to the Physiology of the Brain, 26  
 Capture of Comets by Planets, Prof. H. A. Newton, 186  
 Carbonyl, Iron, from Water Gas, A. E. Tutton, 36; Mond and Langer on, 89; Berthelot on Nickel Carbonyl, 89  
 Carllil (S. R.), Notes on Zebras, 526  
 Carpenter (Dr. Alfred), Death of, 323  
 Carpenter (W. B., F.R.S.): the Microscope and its Revelations, 313; on Eozoon, Sir J. William Dawson, F.R.S., 461  
 Carr (George S.), on the Terms Centrifugal Force and Force of Inertia, 463  
 Carruthers (J.), Appointed Lecturer in Botany at the College of Agriculture, Downton, 586  
 Carter (Miss Alice), Evolution in Methods of Pollination, 596  
 Carus-Wilson (C.), Warning against the Use of Rotten Flints for Macadamizing Roads, 379  
 Carvalho (E.), Crystalline Absorption and the Choice between the Different Terms of Light, 528  
 Castello (F. de), Viticulture for Victoria, 324  
 Casuarinaceæ, Fertilization of the, 548  
 Cat, Origin of the, in China, Dr. Macgowan, 285  
 Cave, the Adelsberg, 207  
 Celestial Mechanics, Two New Laws of, H. Struve, 70  
 Centenarian, Prof. Ignace Vonberg, 518  
 Centrifugal Force and Force of Inertia, on the Terms, George S. Carr, 463  
 Century Dictionary, the, W. Dwight Whitney, 316  
 $\mu$  Cephei, Observations of, J. E. Gore, 137  
 Cepheus, Two New Variables in, Paul S. Yendall, 570  
 Ceratodus, the Lung Fish of Queensland, on the Habits of, Prof. Spencer, 425  
 Ceylon and Borneo, About, Walter J. Clutterbuck, 149  
 Chadwick (W. I.), the Leach Lantern Microscope, 47  
 Chaix (M.), Temperature Observations at Geneva, 304  
 Challenger, Report on the Scientific Results of the Voyage of H.M.S., during the years 1873-76, Prof. John Judd, F.R.S., 409  
 Chambers's Encyclopædia, 196  
 Chambréant (M.), Reclaiming and Cultivation of Land in the Camargue, 143  
 Champignons, Les, A. Acloque, 222  
 Chandler (Dr. S. C.): on the Variation of Latitude, 117, 404, 589; Algol, 446  
 Changefulness of Temperature as an Element of Climate, 610  
 Chappuis (James), Refraction of Liquefied Gases, 384  
 Charpy (Georges): the Direct Combination of Metals with Chlorine and Bromine, 47; Vapour Tensions of Cobalt Chloride Solutions, 167; the Density of Aqueous Solutions, 480  
 Chassevant (A.), a Double Chloride of Copper and Lithium, 72  
 Chauveau (Prof.): his Laboratory at the Paris Museum of Natural History, 86; elected President of the Société de Biologie, 612  
 Cheal (J.), Practical Fruit Culture, 579  
 Cheddar Cheese-making, Experiments in, 614  
 Chemistry: Isolation of Free Hydroxylamine, 20; Alum Solution, T. C. Porter, 29; Prof. Pictet's Laboratory at Berlin, Prof. R. du Bois-Reymond, 31; Results of Experiments at Rothamsted on the Question of the Fixation of Free Nitrogen, Dr. J. H. Gilbert, F.R.S., 32; Fixation of Nitrogen of Arable Soils, Gautier and Drouin, 192; the Fixation of Free Nitrogen of Plants, Schloëing, Jun., and Laurent, 143; Prizes offered by the Royal Danish Academy of Sciences, 134; the Spontaneous Oxidation of Humic Acid and Vegetable Soil, Berthelot and André, 288; Iron Carbonyl from Water Gas, A. E. Tutton, 36; Experiments on the Production of Ozone by Electric Silent Discharge, Siemens and Halske, 39; Sulphides and Selenides of Boron and Silicon Selenide, Paul

Sabater, 41; Butylene Monobromides, E. Reboul, 47; the Direct Combination of Metals with Chlorine and Bromine, Gautier and Charpy, 47; a New Hydroxylamine, Dr. de Bruyn, 48; a Text-book of Chemical Physiology and Pathology, W. D. Halliburton, Dr. E. H. Starling, 51; Two New Phospho-iodides of Boron, H. Moissan, 67; Action of Aqueous Solution of Ammonia on Phthalic Chloride, Hoogewerff and van Dorp, 72; a Double Chloride of Copper and Lithium, A. Chassevaut, 72; Existence of Acid or Basic Salts of Monobasic Acids in very Dilute Solutions, D. Berthelot, 72; Arithmetical Exercises in Chemistry, Leonard Dobbin, 76; Mond and Langer on Iron Carbonyl, 89; Berthelot on the Oxidation of Nickel Carbonyl, 89; Chemical Society, 92, 213, 262, 382, 429, 454, 525, 550, 623; Prof. Bunsen and the Chemical Society, 469; Magnetic Rotatory Power of Solutions of Ammonia and Sodium Salts of Fatty Acids, Dr. W. H. Perkin, F.R.S., 92; Action of Water Gas on Iron, Roscoe and Scudder, 92; Dissociation of Liquid Nitrogen Peroxide, J. T. Cundale, 92; Ortho- and Para-nitro-ortho-toluidine, Green and Lawson, 92; Gueda Gums, the Dextro-rotatory Varieties, C. O'Sullivan, 93; Some Compounds of Oxides of Silver and Lead, Emily Aston, 93; Electrolysis of Potassium Acetate Solutions, Dr. T. S. Murray, 93; New Method of Preparing  $\beta$ -dinaphthylene Oxide, Hodgkinson and Limpach, 93; Van der Waals's Generalizations regarding Corresponding Temperatures, Pressures, and Volumes, Prof. Sydney Young, 93; Heat of Formation of Hydrazine and Hydrozoic Acid, Berthelot and Matignon, 95; the Dielectric Power, Julien LeFebvre, 95; Treatise on the Manufacture of Sulphuric Acid, George Lunge, Ph.D., Prof. T. E. Thorpe, F.R.S., 121; a Hand-book of Industrial Organic Chemistry, Samuel P. Sadtler, 125; Further Researches upon Azobimide, N<sub>3</sub>H, A. E. Tutton, 127; Phosphides of Boron, Moissan and Besson, 136; the Bromine Derivatives of Methyl Chloride, A. Besson, 143; the Ammonia in the Air and Rain of a Tropical Region, Marciano and Muntz, 143; Attraction of Liquid Oxygen by Faraday Magnet, Prof. Dewar, 154; Curious Compound of Lead Sodium and Ammonia, Joannis, 158; Vapour Tensions of Cobalt Chloride Solutions, Georges Charpy, 167; Thermal Data concerning Active Malic Acid and Potassium and Sodium Malates, G. Massol, 167; Ammonia in Atmospheric Waters, Albert Lévy, 168; Chemical Constitution of Adenin and Hypoxanthin, Dr. Krüger, 168; two New Methods of preparing Free Solid Hydroxylamine, M. Crismer, 185; the Three Basicities of Phosphoric Acid, D. Berthelot, 192; a Green Solid Chromic Sulphate, A. Recoura, 192; Crystallization of Tetra-iodide of Carbon, M. Moissan, 209; Phosphorous Oxide, ii., Thorpe and Tutton, 213; Frangulin, ii., Thorpe and Miller, 214; Structure and Chemistry of Flames, Smithells and Ingle, 214; the Structure of Luminous Flames, A. Smithells, 214; Mydatic Alkaloid Hyoscyamine in Lettuce, T. S. Dymond, 214; Cryptopine, Brown and Perkin, 214; Action of Sodium on Etheral Salts, iii., Benzyl Ortho-tolate, R. W. Hodgkinson, 214; New Compounds of Carbonyl Platinum Chloride and Bromide with Ammonia Derivatives, Dr. Foerster, 236; Molecular Weight of Gadolinia, 237; Metallic Borates, H. Le Chatelier, 240; a Silicon Chlorosulphide, A. Besson, 240; Influence of Isomorphism on Behaviour of Double Salts during Solution, Dr. Bakhus Roozeboom, 240; the Chemistry of Paints and Paintings, A. H. Church, F.R.S., Dr. Hugo Müller, F.R.S., 241; Colour and Spectrum of Free Gaseous Fluorine, Moissan, 260; Metallic Hydro-sulphides, Linder and Picton, 262; Physical Composition of some Sulphide Solutions, H. Picton, 263; Solution and Pseudo-Solution, ii., Picton and Linder, 263; Change in Acidified Solution of Sodium Thiosulphate, when Products retained within System, A. Colefax, 263; Action of Sulphurous Acid on Flowers of Sulphur, A. Colefax, 263;  $\alpha$  and  $\beta$  Modifications of Chloro-benzene Hexachloride, F. E. Matthews, 263; Sulphochlorides of Isomeric Dibromonaphthalenes, Armstrong and Rossiter, 263; Action of Alcohols on Sulphonic Chlorides as means of producing Etheral Salts of Sulphonic Acids, Armstrong and Rossiter, 263; Action of Bromine on Mixture of Ortho- and Paranoitro- $\alpha$ -acennaphthalide, Armstrong and Rossiter, 263; Camphrene, Armstrong and Kipping, 263; Metaxylenesulphonic Acids, ii., G. T. Moody, 263; Direct Combination of Nitrogen with the Alkaline Earthy Metals, Maquenne, 264; Nitration of Hydrocarbons of the Methane Series, Konowloff, 264; Magnesium Nitride, Dr. Merz, 280; Manganates of Potash, G. Rousseau, 288; Outlines of Practical Physiological

Chemistry, F. Charles Larkin and Randle Leigh, 292; Problems in Chemical Arithmetic, E. J. Cox, 293; New Liquid Compound of Carbon, Oxygen, and Chlorine, M. Fauconnier, 306; Lithium Nitride, Dr. Merz, 307; Origin of Flame Coloration, Prof. Smithells, 306; Composition of Iolite, O. C. Farrington, 310; a Series of Cesium Trihalides, H. L. Wells, 310; Action of Carbon Monoxide on Iron and Manganese, M. Guntz, 311; Chloride of Sodium in Plants, P. Lesage, 312; the Indexing of Chemical Literature, 324; Remarkable Series of Compounds of Halogen Salts of Cæsium, with two more Atoms of Chlorine, Bromine, or Iodine, Wells and Penfield, 325; the Characteristic Equation of Water Vapour, Ch. Antoine, 336; the Estimation of Molybdenum, E. Péchard, 336; Guide to the Examinations in Chemistry, W. Jerome Harrison, 342; Two New Compounds of Carbon, Chlorine, and Bromine, M. Besson, 351; Barium and Strontium Nitrates, M. Maquenne, 360; Action of Metals on Salts dissolved in Organic Liquids, Raoul Varet, 360; Experiment illustrating the Power of Palladium of excluding Hydrogen, Prof. Wilson, 380; Certain Ternary Alloys, v., C. R. A. Wright, F.R.S., 381; the Luminosity of Coal Gas Flames, V. B. Lewes, 382; the Action of Dilute Nitric Acid on Coal, R. J. Friswe I, 383; a Pure Fermentation of Mannitol and Dulcitol, Frankland and Frew, 383; Synthesis of Hexahydro-terephthalic Acid, Mackenzie and Perkin, 383; Magnetic Rotation of Dissolved Salts, W. Ostwald, 383; the Dissociation of Nitrogen Peroxide, W. Ostwald, 383; Corydalone, Dobbie and Lauder, 383; Silver Compounds of Thiourea, J. E. Reynolds, 383; Determination of Freezing Point of very Dilute Solutions, as applied to Cane-sugar, M. Raoult, 384; Refraction of Liquefied Gases, James Chappuis, 384; Decomposition of Sulphurous Acid by Water at very High Temperatures, M. Scheurer-Kestner, 384; Chlorosulphide and Bromosulphide of Lead, F. Parmentier, 384; Manual of Chemical Technology, Rudolf von Wagner, 386; Interesting Compound of Carbon and Barium, M. Maquenne, 403; a New Method of Organic Analysis, M. Berthelot, 408; Action of Alkaline Metals on Boric Acid, H. Moissan, 408; Variation with Temperature of Dielectric Constant of Liquids, D. Negreano, 408; Zeitschrift für Anorganische Chemie, 421; the Preparation of Amorphous Boron, M. Moissan, 421; on the Progress of Chemistry in Australasia, W. M. Hamlet, 423; A. Liversidge, F.R.S., on the Rusting of Iron, 424; Pedetic Motion in relation to Colloidal Solution, W. Ramsay, 429; the Acid Action of Drawing-papers, W. N. Hartley, 430; the Interactions occurring in Flames, Sir G. G. Stokes and Dr. Armstrong, 430; Properties of Alcoholic and other Solutions of Mercuric and other Chlorides, S. Skinner, 430; the Isothermals of Mixtures of Gases, Prof. Tait, 431; Researches on Ethyl Monochlor-, Monobrom-, and Monocyanacetate, Haller and Held, 432; Tartronic Acid and Tartrates of Sodium and Potassium, G. Massol, 432; Prize offered by Schnyder von Wartensee's (Zurich) Foundation, 443; Chromosulphuric Acid, M. Recoura, 445; Phosphorous Oxide, A. E. Tutton, 446; Search for a Cellulose-dissolving Enzyme in Digestive Tract of certain Grain-feeding Animals, H. T. Brown, 452; on the Influence of Oxygen and Concentration on Fermentation, A. J. Brown, 453; Limettin, W. A. Tilden, 453; the Acid Action of Drawing-papers, Prof. Hartley, 453; the Heats of Formation of Potassium Carballylates, G. Massol, 456; the Composition of Hæmoyanin, M. Zune, 456; Milk Ferment identical with "Kefyr" in use in Canada and United States, C. L. Mix, 471; New Mode of Synthesizing Tartaric Acid, M. Genvesse, 472; the Density of Aqueous Solutions, Georges Charpy, 480; a Study of the Velocity of Decomposition of Diazo-compounds of Water, P. T. Muller and J. Hauser, 480; the late Prof. Stas's "Silver" (the results of further Stöchiometrical Investigations), Prof. Spring, 497; the Action of Dry Hydrochloric Acid Gas on Dry Carbonates, Wilson and Hughes, 503; Researches on Samarium, Lecoq de Boisbaudran, 504; Periodic Heat Maxima observed in Spectra furnished by Flint and Crown Glass and Rock Salt, M. Aymonnet, 504; some Well-defined Alloys of Sodium, M. Joannis, 504; Citric Acid, G. Massol, 504; Pyrogenous Hydrocarbons formed in the Compressed Gas Industry, A. Brochet, 504; a Treatise on Chemistry, Sir H. E. Roscoe, F.R.S., and C. Schorlemmer, F.R.S., 509; Prof. Ignace Vonberg, 518; the Properties of Amorphous Boron, A. E. Tutton, 522; Rule for determining whether a

- given Benzene Mono-derivative shall give a Meta-di-derivative or a Mixture of Ortho- and Para-di-derivatives, Brown and Gibson, 525; Relative Orienting Effect of Chlorine, (1) the Constitution of Parabrom- and Parachloranilinesulphonic Acids, Armstrong and Briggs, 525; Anhydrides of Sulphonic Acids, H. E. Armstrong, 525; the Aconite Alkaloids, ii., Dunstan and Umney, 525; Do., iii., Dunstan and Passmore, 525; the Carbon deposited by Coal Gas Flames, W. Foster, 525; Chromic Acid, Eleanor Field, 525; Origin of Acetylene in Flames, V. B. Lewes, 525; the Properties of Amorphous Boron, H. Moissan, 527; Combinations of Cuprous Iodide with Ammonium Thiosulphate, E. Brun, 528; the Principles of Chemistry, D. Mendeléeff, 529; Synthesis of Two New Liquids containing Fluorine, M. Meslans, 547; Conditions of Combination between Cyanides of Zinc and Mercury, W. R. Dunstan, 550; Lecture Experiment to Illustrate Phenomena of Coal Dust Explosions, T. E. Thorpe, 551; Production of Ketone 1 : 2 : 4; Acet-orthoxylylene from Camphor by Action of Sulphuric Acid and Zinc Chloride, Armstrong and Kipping, 551; Platinum Tetrachloride, W. Pullinger, 551; a New Acid from Camphoric Acid, W. H. Perkin, Jun., 551; Specific Rotatory and Cupric Reducing Power of Invert Sugar, and of Dextrose obtained from Cane Sugar by Means of Invertase, J. O'Sullivan, 551; Ethyldimethylamidobenzene, Hodgkinson and Limpach, 551; Action of Nitric Acid on Oxanilide and its Analogs, A. G. Perkin, 551; Action of Potassium Fluoride on Anhydrous Chlorides, C. Poulsen, 552; Anhydrous Sulphates of Zinc, Nickel, Copper, and Cobalt obtained in Crystals, M. Klobb, 569; the Difference of Colloid Oxides and Crystalline Hydrates, Van Bemmelen, 576; Ethylalldoxime, Franchimont, 576; Quantitative Chemical Analysis, Frank Clowes and J. Bernard Coleman, 578; Titanium Phenylate and other Compounds in which Hydroxylic Hydrogen of Phenols is replaced by Titanium, M. Levy, 589; Recent Advances in Physical Chemistry, Prof. W. Ostwald, 590; Experiments on the Inert Layer in Emulsions of Chloroform and Soda, Dr. Budde, 599; Outlines of Theoretical Chemistry, Lothar Meyer, Prof. M. P. Pattison Muir, 601; Synopsis of Non-Metallic Chemistry, William Briggs, 604; Chemical Calculations, R. Lloyd Whiteley, 604; Silent Combination of Hydrogen and Oxygen, Prof. Victor Meyer and Herr Askenasy, 616
- Cheshire (F.), Wave Motion Model, 347
- Chicago, the Congress of Electricians at, 19
- Chicago Exhibition: Australia and the, 113; Economic British Minerals at the, 155; Proposed Indian Bureau Exhibit, 184; Proposed U.S. Patent Office Exhibit in Illustration of Progress of Mechanical Civilization, 207; Messrs. Siemens and Halske's Exhibit (Electrical Engineering), 207; Prof. Putnam's Anthropological Exhibit at, 259; the English Electrical Exhibit, 377; Cabot Relics to be sent to, 443; Electricity Building at, 443; Monster Steam Hammer, 497; the South African Diamond Industry at, 567; Leather Industry at the, 587; Use of Mica at the, 615
- Chilton (Charles), a New Isopod, 66
- China, the Origin of the Ass, the Cat, and the Sheep in, Dr. Macgowan, 285
- China, the Manchu Race, 523
- China to Simla, Capt. Bower's Journey from, 615
- Chinese Fibres, 278
- Chloroform and Soda, Experiments on the Inert Layer in Emulsions of, Dr. Budde, 599
- Chree (C.): Long Rotating Circular Cylinders, 455; Change in Dimensions of Electric Solids due to given System of Forces, 527
- Chromosphere Spectrum, Note on the, Prof. C. A. Young, 28
- Chromosphere Line Ångström 6676'9, Rev. A. L. Cortie, 103; Prof. C. A. Young, 198
- Chronophotography: Use of, for Study of Aerial Locomotive Machines, Marey, 71; Chronophotography or Photography as Applied to Moving Objects, 228
- Church (A. H., F.R.S.), the Chemistry of Paints and Paintings, Dr. Hugo Müller, F.R.S., 241
- Circulation of the Atmosphere, the General, Dr. J. M. Pernter, 593
- Cirques, Prof. T. G. Bonney, F.R.S., 391; Prof. G. Frederick Wright, 317; Prof. Israel C. Russell, 317
- City and Guilds of London Institute, Report on 1891 Technological Examinations, 38
- Civilization, Ancient, of Central America, Alfred P. Maudslay, 617
- Clarke (Sir Andrew, F.R.S.), Elected (fifth time) President of Royal College of Physicians, 566
- Clarke (W. E.), the Great Skua in Scotland, 545
- Clerke (A. M.), Œuvres Complètes de Christian Huygens, 434
- Climate of British Empire during 1891, 38
- Climate, Changefulness of Temperature as an Element of, 610
- Climatology: the Weather Bureau of the United States, 36; Projected Exhibition of Instruments, &c., relating to, 258
- Cloud Observations at Sea, Prof. C. Abbe, 70
- Clouds, Luminous, Proposals for a Co-operative Observation of the So-called, 117
- Clouds, Nacreous, T. W. Backhouse, 365
- Clowes (Frank and J. Bernard Coleman), Quantitative Chemical Analysis, 578
- Clutterbuck (Walter J.), About Ceylon and Borneo, 149
- Coagulation of the Blood, Pekelharing, 600
- Coal on Tenasserim River, Discovery of, 496
- Coal-Dust Explosion, Lecture Experiment to illustrate Phenomena of, T. E. Thorpe, 551
- Cobelli (Dr. R.), Movements of the Flower and Fruit of *Erodium grinum*, 478
- Cocoid, the *Icerya purchasi* at St. Helens, 115
- Cockerell (T. D. A.), Alpine Rubi, 320
- Cocoa-nut Palms of Jamaica, Disease among the, 88
- Cocoons, Variations in the Colour of, W. Bateson, 143
- Cohen (E.), Meteoric Iron, 69
- Coke Industry, the Utilization of the By-products of the, Dr. B. Terne, 157
- Colchester, Capture of a Spotted Eagle near, 158
- Cole (F. N.), Klein's Modular Functions, 597
- Cole (Prof. G. A. J.), the Variolite of Annalong, Co. Down, 455
- Colefax (A.): Change in Acidified Solution of Sodium Thiosulphate when Products retained within System, 263; Action of Sulphurous Acid on Flowers of Sulphur, 263
- Coleman (J. Bernard) and Frank Clowes, Quantitative Chemical Analysis, 578
- Colleges, University, in Great Britain, Report of Committee on Grants to, 544
- Colliding Bodies, the Virial of a System of Hard, Lord Rayleigh, F.R.S., 80
- Colliery Manager's Hand-book, Caleb Pameley, 77
- Collins (F. Howard), Migration of the Lemming, 149
- Colloid Solutions, on the Nature of, C. E. Linebarger, 622
- Colot (Edmond), on the Tensions of Saturated Vapours of Different Liquids at the same Pressure, 528
- Colour, First Visible, of Incandescent Iron, Capt. A. Noble, F.R.S., 484
- Colour Blindness, Hering on a Rare Case of, 115; and Colour Perception, F. W. Edridge Green, 195
- Colour Photography by Lippmann's Process, 119
- Colour Photometry, Captain Abney, 213; First Visible Colour of Incandescent Iron, Capt. A. Noble, F.R.S., 484
- Colours of Fish and other Animals, a Medium for Preserving the, 212
- Colours, Warning, Frank E. Beddard, 78; Edward B. Poulton, F.R.S., 174; W. L. Distant, 174
- Colours, Supplementary, Prof. S. P. Thompson, F.R.S., 452
- Colours, on Insect, F. H. Perry Coste, 513, 541
- Colson (Albert), on the Flow of Liquids in Capillary Tubes, 120
- Columbia, British, the Similkameen Indians of, Mrs. Allison, 164
- Columbia College, New York, Electrical Engineering at School of Mines, 207
- Columbus Marine Biological Station at Jamaica, Proposed, 401; Prof. Ray Lankester, 420
- Columbus, Quatercentenary of Discovery of America by, Botanical International Congress to be held at Genoa in connection with Celebration, 545
- Comenius (Johann Amos), Tercentenary of Birth of, 495
- Cometary Matter, Refractive Power of, E. E. Barnard, 237
- Comets: Tempel-Swift's Periodic Comet, 21; Tempel-Swift Comet, 159; Comet Swift, March 6, 548; Wolf's Periodic Comet, 42; Dr. Berberich, 237; Wolf's Comet, 1891 II., Herr Dr. Thraen, 548; Capture of Comets by Planets, Prof. H. A. Newton, 186; Re-discovery of Brooks's Comet (1890 II.), 326; a New Comet discovered by Prof. Lewis Swift, 446; Prof. Krueger on Motions of Periodic Comets, 446; a Bright Comet, 473; New Comet, W. F. Denning, 484, 513;



- Denning's Comet (*b* 1892), Dr. R. Schorr, 569; Comet Swift 1892, 569; Winnecke's Comet, Dr. G. F. Haerdtl, 617
- Commerce, Evolution of, Gardiner G. Hubbard, 588
- Conchology of the West Coast of South America, Robert E. C. Stearns, 89
- Congo, French, Copper Mines of, 135
- Congress, Botanical International, to be held at Genoa in connection with Celebration of Quatercentenary of Discovery of America by Columbus, 545
- Congress at Chicago, Proposed International Electrical, 64, 278
- Connaissance des Temps, 186
- Conn (Prof. H. W.), the Living World, Whence it Came and Whither it is Drifting, 317
- Cons (Miss E.), Polytechnics and Recreation, 28
- Coode (Sir John), Death of, 443
- Cooke (M. C.), British Edible Fungi, 75
- Cope (Prof. E. D.), Discovery of New Species of Frog in New Jersey, 208
- Copeland (Ralph): New Star in the Milky Way, 325; New Star in Auriga, 454, 527
- Copernic et la Découverte du Système du Monde, Camille Flammarion, 77
- Copper Mines of French Congo, 135
- Copper-mining on Lake Superior, Prehistoric Mines in Neighbourhood, E. B. Hinsdale, 39
- Cordova Observatory, 446
- Corleone, Earthquake at, 184
- Cornaglia (Signor), Sul Regime delle Spiagge e sulla Regolazione dei Porti, 362
- Cortie (Rev. A. L.), the Chromosphere Line Ångström 6676'9, 103
- Coste (F. H. Perry): Salts in Natural Waters, 176; on Insect Colours, 513, 541; Pigments of Lepidoptera, 605
- Cotes (E. C.), the Wild Silk Insects of India, 520
- Cottrell (Prof. James A., F.R.S.), Superheated Steam, 414
- Cotter (M.), Photography of the Eclipsed Moon, 117
- Cox (E. J.), Problems in Chemical Arithmetic, 293
- Cranbrook (Lord), and the University Extension Movement, 155
- Crane (Agnes), the Mexican Atlatl or Spear-Thrower, 102
- Crawford (A.), Results of the Government Travelling Dairy in Victoria, 39
- Crawshaw (Mrs. R. M.): the Recent Eclipse of the Moon, 134; a Double Moon, 224
- Cremation, Progress of, 379
- Crew (Dr. Henry), Observations of the Spectrum of Nova Aurigæ, 569
- Crichton-Browne (Harold), Dwarfs and Dwarf Worship, 269
- Crime, Photography applied to the Detection of, Dr. Paul Jeserich, 568
- Crismer (M.), Two New Methods of preparing Free Solid Hydroxylamine, 185
- Crocuses, Sparrows and, R. McLachlan, F.R.S., 441
- Croft (W. B.): Nickel Heat Engine, 392; Sensitive Water Jets, 606
- Cromer Drift, Striated Surface under the, William Sherwood, 513
- Crookes (Prof. W., F.R.S.), Electricity in Relation to Science, 61
- Croonian Lectures, 19
- Crops, Farm, J. Wrightson, 247
- Cruise on the Broads, How to Organize a, E. R. Suffling, 52
- Crum (John), Prof. Wiborgh's Air Pyrometers, 304
- Crustacea, Freshwater: a New "Isopod," Charles Chilton, 66
- Cryptogams: British Edible Fungi, M. C. Cooke, 75
- Crystal Palace Electrical Exhibition, the Coming, 64
- Crystal Palace Electrical Exhibition, 113, 261, 356
- Crystals, Ice, Gilbert Rigg, 319; Bernard Hobson, 365
- Cuckoo, Torpid, A. Holte Macpherson, 416
- Cundale (J. T.), Dissociation of Liquid Nitrogen Peroxide, 92
- Cunningham (Dr. D. J., F.R.S.), the Skeleton of the Irish Giant Cornelius Magrath, 147
- Cunningham (Prof. J. T.), Growth of the Pilchard or Sardine, 255, 558
- Cunningham (Rev. Prof. W.), the Relativity of Economic Doctrine, 519
- Cuthbertson (Clive), Mental Arithmetic, 78
- Cyclone Memoirs of the Arabian Sea, W. L. Dallas, 135
- Cyclone, the Samoan, of March 16, 1889, 161
- Cyclone in Siam, 86
- Cyclones in the Arabian Sea, 276
- Cyclones in Europe, 114
- Cyclopædia of Nature Teachings, H. Macmillan, 248
- Cygni, the Relative Motion of 61, Prof. A. Hall, 547
- Cygnus, Photographs of a Part of, M. Faye, 624
- Cyst, Formation of a Temporary, in the Fresh-water Annelid *Zoosoma*, Frank E. Beddard, 28
- Czapski (Prof.), the Calculable Limit of Microscopic Views, 575
- Daffodil in the Basses Pyrénées, Extermination of the Wild, 545
- Dairy Farming in Victoria, Results of the Government Travelling Dairy, A. Crawford, 39
- Dakyns (J. R.), the Plutonic Rocks of Garabal Hill and Meall Breac, 360
- Dallas (W. L.), Cyclone Memoirs of the Arabian Sea, 135
- Dallinger (Rev. W. H., F.R.S.), the Microscope and its Revelations, W. B. Carpenter, F.R.S., Prof. E. Ray Lankester, F.R.S., 313
- Darwin (Charles), Boehm's Statue of, 19
- Darwin (Francis, F.R.S.), elected Member of Athenæum Club, 566
- Darwin (Prof. G. H., F.R.S.): the Capture of Lexell's Comet by Jupiter, 526; "The Cause of an Ice Age," Sir Robert Ball, F.R.S., 289
- Darwinian Society of Edinburgh, the, 19; William White, 53; John S. Flett, 104
- Dary (George), L'Electricité dans la Nature, 460
- David (T. W. E.), on Volcanic Action in Eastern Australia and Tasmania, 424
- Davis (Floyd), "An Elementary Hand-book on Potable Waters," Prof. Percy F. Frankland, F.R.S., 25
- Davison (C.), the Elements of Plane Trigonometry, 509
- Dawes (Prof. W. M.), Ferrel's View of the General Circulation of the Atmosphere, 357
- Dawson (Sir J. William, F.R.S.), Dr. Carpenter, on Eozoon, 461, 606
- Deep-Sea Deposits (*Challenger* Expedition), Murray and Renard's Report on, Prof. John Judd, F.R.S., 409
- Delagoa Bay, its Natives and Natural History, Rosa Monteiro, 124
- Deniker (J.), and P. Hyades, Mission Scientifique de Cap Horn, 577
- Denning (D.), the Art and Craft of Cabinet-Making, 459
- Denning (W. F.): the Red Spot on Jupiter, 272; Large Meteor of January 24, 1892, 317; Rotation of Jupiter, 473; New Comet, 484; a New Comet, 513
- Denning's Comet (*b* 1892), Dr. R. Schorr, 569
- Derrecagaix (General), New Measurement of the Perpignan an Base, 384
- Deslandres (M.), the Motion of Stars in the Line of Sight, 117; Photography of Solar Prominences, 404, 522
- Determinants, the Theory of, in the Historical Order of its Development, Thomas Muir, 481
- Deutsches Meteorologisches Jahrbuch, 1890, 587
- Devonian Limestone of South Devon, on the Microscopic Structure and Residues insoluble in Hydrochloric Acid in the, Edward Wethered, 597
- Devonshire, the late Duke of, and Science, 182
- Devonshire (Duke of), Election to Chancellorship of the University of Cambridge, 233; Preliminary Installation as Chancellor of University of Cambridge, 257
- Dewar (Prof.), Attractions of Liquid Oxygen by Faraday Magnet, 154
- Dewdney (Hon. E.), Aborigines of the Dominion of Canada, 587
- Diamond Industry at the Chicago Exhibition, the South African, 567
- Diamonds in the Iron, a new Locality for Meteoric Iron, with a Preliminary Notice of the Discovery of, Prof. A. E. Foote, 178
- Diatoms, Alleged Pseudopodes of, Alfred W. Bennett, 177
- Dictionary, the Century, W. Dwight Whitney, 316
- Dielectric Power, the, Julien Lefebvre, 95
- Dietrich (Dr. F. C.), Death of, 155
- Diffraction Effects produced by placing Screens in Front of Object Glasses, Prof. Pritchard, 237
- Dines (W. H.), Anemometer Comparisons, 623
- Dinornis*, Evidence of a Wing in, Henry O. Forbes, 257
- Diphtheria, its Natural History and Prevention, by R. Thorne Thorne, F.R.S., 123
- Diptera, an Account of British Flies, Hon. M. Cordelia E. Leigh and F. V. Theobald, 173
- Disease, a Zoologist (Dr. Elie Metschnikoff) on, Prof. E. Ray Lankester, F.R.S., 505

- Distant (W. L.), Warning Colours, 174  
 Distribution of Energy in Stellar Spectra, Prof. Pickering, 159  
 Dittmar (William), Obituary Notice of, 493  
 Dixon (Edward T.), the Implications of Science, 125, 272, 391  
 Dixon (J. E.), Curious Death of a Ring-tailed Opossum, 88  
 Dixon (Mr.), the Logical Foundations of Applied Mathematical Sciences, 407  
 Dobbie (J. J.), Corydaline, 383  
 Dobbin (Leonard), Arithmetical Exercises in Chemistry, 76  
 Dog, the Anatomy of, 16  
 Dog, the Tubercular Vaccination of the, Héricourt and Richet, 576  
 Dog working in a Treadmill, Assimilation of Diet investigated on a, Dr. Rosenberg, 599  
 Dogs, Intelligence of, 177  
 Dorp (W. A. van), Action of Aqueous Solution of Ammonia on Phthalic Chloride, 72  
 Double Orange, Gerald B. Francis, 607  
 Downing (F. S.), Death of, 85  
 Draper Catalogue of Stellar Spectra, A. Fowler, 427  
 Dredging Operations in the Eastern Pacific, Prof. Alexander Agassiz, 281  
 Drouin (R.), Fixation of Nitrogen by Arable Soils, 192  
 Du Bois-Reymond (Prof. E., F.R.S.), on the Relation of Natural Science to Art, 200, 224  
 Dublin Royal Society, 166, 287, 407, 455  
 Dublin, Trinity College, Tercentenary Celebration of, 378  
 Dufour (M.), Influence on Electro-Magnetic Resonance of Unsymmetrical Arrangement of Propagation Circuit, 408  
 Dundas (Capt.), Expedition to Mount Kenia in East Africa, Ernest Gedge, 566  
 Dunn (Matthias), Pilchards, 511  
 Dunstan (W. R.), the Aconite Alkaloids, ii. and iii., 525; Conditions of Combination between Cyanides of Zinc and Mercury, 551  
 Duppa-Crotch (H. W.), Migration of the Lemming, 199, 294  
 Durham (H. E.), Wandering Cells in Echinoderms, &c., 450  
 Durrant (Reginald G.), a Lecture Experiment on Sound, 415  
 Dust Particles, on the Number of, in the Atmosphere of Various Places in Great Britain and on the Continent, with Remarks on the Relation between the Amount of Dust and Meteorological Phenomena, John Aitken, F.R.S., 299  
 Dust Counting on Ben Nevis, Angus Rankin, 582  
 Dutch Academy of Sciences, Haarlem, Prize Subjects proposed by, 37  
 Dwarfs of Mount Atlas, the, R. G. Haliburton, 66  
 Dwarfs and Dwarf Worship, Harold Crichton-Browne, 269  
 Dyer (J. M.), Elementary Trigonometry, 174  
 Dyer (W. T. Thiselton, F.R.S.), Botany of the Emin Relief Expedition, 8; Instruction in Horticulture, 402  
 Dymond (T. S.), Mydatic Alkaloid Hyoscyamine in Lettuce, 214  
 Dynamic Action and Ponderosity of Matter, by "Waterdale," 100  
 Dynamics and Statics, Rev. J. B. Lock, 101  
 Eagle, Spotted, Capture near Colchester, of, 158  
 Earth Vibrations, on, Dr. Emil Oddeone, 510  
 Earth's Shadow, Increase of, during Lunar Eclipses, Dr. Hartmann, 498  
 Earthquakes: in Japan, 286; Effects of Earthquake in Japan, 38; Seismometry and Engineering in relation to the recent Earthquake in Japan, Prof. John Milne, F.R.S., 127; the recent Earthquake in Japan, Prof. F. A. Forel, 199; Earthquake-observing Stations in Japan, 471; Earthquake at Pantelleria, 120; at Corleone, 184; in Jamaica, 207; in Italy, Greece, and New York State, 259; in Rome (Province) and France, 304; in California, 471, 614; in Nicaragua, 471; Effect of Earthquakes on Vegetation, Signor Goiran, 520; Earthquake at Portland, Oregon, 586 (*see also* Seismology)  
 Earthworm, a Rare British, Rev. Hilderic Friend, 365  
 Echinoderms collected during the Fishing Survey on the West Coast of Ireland, Prof. F. Jeffrey Bell, 598  
 Eckert (J. P.), some Peculiar Changes in Colour of Flowers of *Swainsonia procumbens*, 185  
 Eclipse, Total Lunar, of November 15, 42  
 Eclipse of the Moon, Robert C. Leslie, 53  
 Eclipses, Lunar, Increase of the Earth's Shadow during, Dr. Hartmann, 498  
 Economic Congress at Antwerp, Proposed International, 586  
 Economic Doctrine, the Relativity of, Rev. Prof. W. Cunningham, 519  
 Economists, Austrian, William Smart, 268  
 Economy, Political: the Relativity of Economic Doctrine, Rev. Prof. W. Cunningham, 519  
 Edinburgh Royal Society, 239, 311, 431, 454, 527, 623  
 Edinburgh University Darwinian Society, 19, 53, 104  
 Edmunds (Walter), a Treatise on the Ligation of the Great Arteries in Continuity with Observations on the Nature, Progress, and Treatment of Aneurism, Dr. M. Armand Ruffer, 530  
 Education: the Speaker of the House of Commons on Technical Education, 19; Report on 1891 Technological Examinations of City and Guilds of London Institute, 38; the Place due to Horticulture in Technical Education, W. Wilks, 38; True Relation of Technical Education to the Study of Pure Science, Dr. Sorby, 38; Record of Technical and Secondary Education, 65; Scientific and Technical Education in New South Wales, 88; Technical Education in Essex, 155, 234; in Scotland, 377; in London, 403; the New London County Council and Technical Education, 566; Examinations in Science, 85; Lord Cranbrook and the University Extension Movement, 155; Education in the United States, 156; the English Language in Japanese Schools, 303; the Registration of Teachers, 324; Free Education in Ireland, 403; Dr. Thomas Muir appointed Superintendent-General of Education for Cape Colony, 443; the Government and Scientific Education, 470; the Government and the proposed Teaching University for London, 470; Royal Commission to investigate the Question of a Teaching University for London, 612; Tercentenary of the Birth of J. A. Comenius, 495; Report of Committee on Grants to University Colleges in Great Britain, 544  
 Edwards (Amelia B.), Death of, 586; Chair of Egyptology endowed by, 613  
 Edwards (E. P.), Burning Oils for Lighthouses, 379  
 Egg of the Extinct Gigantic Bird of Madagascar, *Aepyornis maximus*, 586  
 Egypt under the Pharaohs, H. Brugsch-Bey, 363  
 Egypt Exploration Fund, the, 470  
 Egypt, Prehistory of, W. M. Flinders Petrie, 580  
 Egyptian Antiquities, proposed Grant on behalf of, 113  
 Egyptian Astronomy, on some Points in Ancient, J. Norman Lockyer, F.R.S., 296, 373  
 Egyptology, Chair of, endowed by Amelia B. Edwards, 613  
 Elder (H. M.), Thermodynamical View of Action of Light on Silver Chloride, 524  
 Electricity: Electricity and Magnetism, translated from the French of Amédée Guillemin, Prof. A. Gray, 1; Proposed International Electrical Congress at Chicago, 19, 64, 85, 278; Electric Snow-sweeper, 39; Experiments on the Production of Ozone by Electric Silent Discharge, Siemens and Halske, 39; an Experiment of Sir Humphry Davy's, G. F. C. Searle, 47; some Notes on Clark's Cells, Glazebrook and Skinner, 47; some Notes on the Fra'kfort International Electrical Exhibition, 54, 105; Electricity in Relation to Science, Prof. W. Crookes, F.R.S., 63; Electrical Exhibition at the Crystal Palace, 64, 113, 261, 356; Experimental Determination of Velocity of Propagation of Electro-magnetic Waves, R. B. Blondlot, 72; Electro-magnet and Electro-magnetic Mechanism, S. P. Thompson, F.R.S., Prof. A. Gray, 73; Electrolysis of Potassium Acetate Solutions, Dr. T. S. Murray, 93; the Dielectric Power, Julien LeFebvre, 95; the Specification of Insulated Conductors for Electric Lighting, W. H. Preece, F.R.S., 155; the Thermal Emissivity of Thin Wires in Air, Ayrton and Kilgour, 162; the Self-induction of two Parallel Conductors, H. M. Macdonald, 166; Electricity in relation to Mining, Ernest Scott, 184; Rotary Currents, Prof. W. E. Ayrton, F.R.S., 191; a Thermo-Electric Standard of Electromotive Force, H. Bagard, 192; Electrical Engineering at School of Mines, Columbia College, New York, 207; Repulsion and Rotation produced by alternating Electric Currents, G. T. Walker, 213; Study of Light and Heat Phenomena accompanying Electrolysis, Lagrange and Hobo, 216; Interference with Alternating Currents, M. H. Kilgour, 238; a First Book of Electricity and Magnetism, W. Ferren Maycock, 248; Electricity on the Stage, 259; Influence of Electric Discharge during Thunderstorms on Apparatus registering Terrestrial Magnetism, Em. Marchand, 264; Electro-capillary Phenomena and Differences of Potential produced by Contact, Gouy, 264; Electrical Exhibition

- at St. Petersburg, 303; the Specifications for Conduit System for Electrical Conductors at Chicago Exposition, 303; Electrical Transmission of Power from Lauffen to Frankfurt, the, 303; Gaseous Carbonic Acid not capable of Generating Electricity by Mechanical Friction on Metal, Prof. Wesendonck, 306; Heat-radiation of Gases under the Electric Discharge, Herr Ångström, 306; Electrotechnics, Prof. W. E. Ayrton, F.R.S., 325; on Hertz Oscillations, A. Perot, 336; Lectures on Alternate Currents of High Potential and Frequency, Nikola Tesla, 345; the Driving of Electro-magnetic Vibrations by Electro-magnetic and Electrostatic Engines, Prof. G. F. Fitzgerald, F.R.S., 358; Vacuum Tubes and Electric Oscillations, Prof. Oliver J. Lodge, F.R.S., 366; Electro-dynamic Theories and the Electro-magnetic Theory of Light, M. Poincaré, Prof. A. Gray, 367; the English Exhibit at the Chicago Exhibition, 377; Electric Fans to blow away Smoke from Guns of American Turret Ship, 403; Influence on Electro-magnetic Resonance of Unsymmetrical Arrangement of Propagation Circuit, Blondot and Dufour, 408; Medical Utilization of Alternating Currents of High Potential, Gautier and Larat, 456; L'Électricité dans la Nature, Georges Dary, 460; Fifteenth Convention of the National Electric Light Association, 470; Modes of representing Electromotive Forces and Currents in Diagrams, Prof. S. B. Thompson, F.R.S., 478; the coexistence of Dielectric Power and Electrolytic Conductivity, E. Bouty, 480; Execution by Electricity, 519; Influence of Electricity on Growth of Plants, Prof. Alois, 520; Choking Coils, Prof. Perry, F.R.S., 524; some Experiments on Electric Discharge, Prof. Thomson, 526; the Manifestation of Negative Electricity during fine weather, Ch. André, 528; the Pittsburgh Electric Club, 568; Electromotive Forces of Gold and Platinum Cells, Prof. Herroun, 574; some Electrical Instruments, R. W. Paul, 574; the Attraction between two Disks separated by a Dielectric, Julien Lefebvre, 575; Experiments on the Electrical Polarization at the two sides of a Metallic Plate immersed in an Electrolyte at Right Angles to the Current, Dr. Arous, 576; Working of the Search Light, W. B. Lefroy Hamilton, 587; Relation of Voltaic Electromotive Force to Molecular Velocity, Dr. G. Göe, F.R.S., 596; Decomposition of Sulphur tested Electrolytically, Dr. Gross, 599; the Behaviour of Spermatozoa towards Electric Currents, Dr. Schweizer, 599
- Elements on the Line Spectra of the, Prof. C. Runge, 607
- Eliot (John), Report on the Meteorology of India in 1889, 217
- Elliott (E. B., F.R.S.)<sup>1</sup> Dualistic Differential Transformation, 503
- Ellison (Allan), Migratory Birds passing over Dublin, 20
- Emin Pasha Relief Expedition, my Personal Experiences in Equatorial Africa as Medical Officer to the, Thos. Heazle Parke, 265
- Emin Relief Expedition, Botany of the, W. T. Thiselton Dyer, F.R.S., 8; Major I. A. M. Jephson, 9
- Encyclopædia, Chambers's, 196
- Endlicher (Stephen), Proposed Monument to, 419
- Energy, Prof. Burnside's Paper on the Partition of, R.S.E., July 1887, S. H. Burbury, F.R.S., 533
- Engelenburg (Mr. E.), the New Director of the Dutch Meteorological Observations on Land, 183
- Engine, a Simple Heat, Fred. J. Smith, 294, 464; Prof. Konstantin Karanate, 416
- Engineering, Sanitary, C. Napier Bell, on, 426
- Engineering, Seismometry and, in Relation to the Recent Earthquake in Japan, Prof. John Milne, F.R.S., 127
- Engineering; the Manufacture and Use of Aluminium from an Engineering Point of View, A. E. Hunt, 568
- Engineers, Annual Meeting of Institution of Mechanical, 355
- England, Kalm's Account of his Visit to, on his way to America in 1748, 412
- English Language in Japanese Schools, the, 303
- Entomology: Silk-producing Moths, Col. Swinhoe, 38; Entomological Society, 46, 71, 166, 430, 454, 526, 575, 623; Presidential Address, F. D. Godman, F.R.S., 359; Mr. Albert Koebele and the Enemies of Insect Pests, Sir James Hector, 65; the Macro-Lepidoptera of Winchester, 115; Le Pamir et sa Faune Lépidoptérologique, Grum-Grshimailo, 115; the *Teerya purchasi* at St. Helena, 115; Variations in the Colour of Cocoons, W. Bateson, 143; Association between Gamasids and Ants, A. D. Michael, 164; a New Herbarium Pest, Dr. C. W. Riley, 235; Dr. Riley's New Herbarium Pest, R. McLachlan, 259; the West Indian Ticks, 303; *Orcus chalybeus*, an important enemy of the Red Scale, M. Koebele, 323; the Insects, &c., that injure Tobacco, Prof. A. T. Tozzetti, 325; Ants' Nest Beetles, J. J. Walker, 351; a new case of Mimicry, Prof. A. Giard, 379; two Species of Indian Ants, E. A. J. Rothney, 454; the Wild Silk Insects of India, E. C. Cotes, 520; the Plague Locust of New South Wales, A. S. Olliff, 520; the Ants attracted by *Cynips calycis* a protection to *Quercus pedunculata*, Dr. Ráthay, 596; Hellebore as an Insecticide, W. W. Smith, 596; Abbreviated Wings of the Male Caddis-fly, R. McLachlan, F.R.S., 623; Dr. Sharp on the Phyllium, 623
- Eozoon, Dr. W. B. Carpenter on, Sir J. William Dawson, F.R.S., 461, 606; the Tudor Specimen of, J. W. Gregory, 486
- Epidemic, a New, in Vienna, 349
- Epidemics, Untenability of Atmospheric Hypothesis of, Hon. R. Russell, 431; the Origin of Influenza Epidemics, H. Harris, 431
- Equation, Virial, for Gases and Vapours, Prof. P. G. Tait, 199
- Equations, Personal, in Transit Observations, 617
- Equator, Travels among the Great Andes of the, Edward Whympy, Prof. T. G. Bonney, F.R.S., 561
- Equatorial Africa, my Second Journey through, Hermann von Wissmann, 507
- Equatorial Forests and Rivers of South America, Adventures amidst the, Willers Stuart, 317
- Ermiling (Dr.), on the Nurhagi of Sardinia, 114
- Eruption North-West of Pantelleria, the October, G. W. Butler, Prof. John W. Judd, F.R.S., 154; on the Matter thrown up during the, Gerard W. Butler, Geo. H. Perry, 251; Abstract of Mr. A. Ricco's Account of the, G. W. Butler, 584
- Eskimo Throwing-Sticks, Prof. O. T. Mason, 66; Agnes Crane, 103
- Essex, Technical Education in, 155, 234, 613
- Ethnology: the Dwarfs of Mount Atlas, R. G. Haliburton, 66; Prints of Havesup-pai Indians, Dr. Shufeldt, 235; Use of the Sumpitan and Bow in Indonesia, C. M. Pleyte, 235; Purchases for the Australian Museum, Sydney, E. P. Ramsay, 324; Surface and Population of European States, E. Levasseur, 528
- Euclid's Elements of Geometry, A. E. Layng, 149
- Euclid II' 9 and 10, Simple Proof of, Miss Hilda Hudson, 189; Perival and Co., 250
- Euclid's Elements, the First Book of, Rev. J. B. Lock, 460
- Eugen (Herr), New Star in Auriga, 473
- Europe, Research on Extremes of Temperature in, Dr. Lachmann, 576
- Europe, Central, the Temperature of the Rivers of, 114
- European States, Surface and Population of, Emile Levasseur, 528
- Evans (Dr. Evan), Death of, 118
- Evaporation on Glacier, Extraordinarily Rapid, Prof. Boernstein, 312
- Everett (Prof. J. D., F.R.S.): Wet and Dry Bulb Formulæ, 95; C.G.S. System of Units, 581
- Evolution of Life, or Causes of Change in Animal Forms, Hubbard Winslow Mitchell, 364
- Evolution of Man, Prof. Ernst Hæckel, 482
- Evolution in Methods of Pollination, Miss Alice Carter, 596
- Ewart (Prof. Cossar) on Scottish Zoology, 87; the Lateral Sense-Organs of Elasmobranchs, 239; the Cranial Nerves of Man and Selachians, 527
- Ewart (Prof. J. G.), the Electric Organ of the Skate, 451
- Examinations in Science, 85
- Execution by Electricity, 519
- Exhibition in Celebration of Quatercentenary of Discovery of America, Projected Spanish, 64
- Exhibition, the Chicago, Economic British Minerals at, 155; Proposed Indian Bureau Exhibit, 184; Proposed U.S. Patent Office Exhibit in Illustration of Progress of Mechanical Illustration, 207; Messrs. Siemens and Halske's Exhibit, Electrical Engineering, 207; Prof. Putnam's Anthropological Exhibit at, 259
- Exhibition, the Coming Crystal Palace Electrical, 64
- Exhibition, Electrical, at St. Petersburg, 303
- Exhibition of Instruments Relating to Climatology, Projected, 258
- Explorers, Two African, 376
- "Extension" Psychology, 76
- Eyes, Peculiar, Jas. Shaw, 104; G. K. Gude, 151; E. B. Titchener, 177

- Fabre (M.), Orthochromatic Plates for Astronomical Photography, 280
- Falconry, a Bibliography of, J. E. Harting, 67
- Famine in Russia, Causes of the, Dr. A. Woeikof, 378
- Farm Crops, J. Wrightson, 247
- Farrington (O. C.), Composition of Iolite, 510
- Fauconner (M.), New Liquid Compounds of Carbon, Oxygen, and Chlorine, 306
- Fauna, Freshwater, of Sumatra, Java, &c., Prof. Max Weber, 408
- Faye (M.), on the Variation in Latitude, 570; Photographs of a part of Cygnus, 624
- Fayrer (Sir Joseph, F.R.S.), elected Corresponding Member of the Royal Academy of Sciences of Lisbon, 585
- Featherwork, Surviving Specimens of Ancient Mexican, 66
- Fens, the Gradual Extinction of many Species of Lepidoptera in the, Dr. Wheeler, 567
- Ferrel's View of the General Circulation of the Atmosphere, Prof. W. M. Davis, 357
- Ferric Oxychloride, a New Crystalline, 24
- Fertilization of the Casuarinaceae, 548
- Féry (C.), a new Spectrometer, 239
- Fewkes (J. W.), the Ceremonial Circuit of the Cardinal Points among the Tusayan Indians, 546
- Fibres, Chinese, 278
- Field Geology, Outlines of, Sir Archibald Geikie, F.R.S., Prof. A. H. Green, F.R.S., 97
- Field (Eleanor), Chromic Acid, 525
- Finland, Meteorology of, 87
- Finlay (George), the Working and Management of an English Railway, 116
- Finnish Archaeology, the late Dr. Reinholm, 496
- Finn (Frank), a Tortoise inclosed in Ice, 320
- Fish and other Animals, a Medium for Preserving the Colours of, 212
- Fish: Destruction of Immature Sea-Fish, Alfred O. Walker, 176; Ernest W. L. Holt, 249; on the Habits of Ceratodus, the Lung Fish of Queensland, Prof. Spencer, 425; Pilchards, Matthias Dunn, 511
- Fisher (Prof. W. R.), Forestry in America, 611
- Fisheries of the Great American Lakes, 259; Fishing through the Ice, 280
- Fisheries, Scotch, 49
- Fison (Rev. Lorimer), on Anthropological Study, 426
- Fitch (Walter Hood), Obituary Notice of, 302
- Fitzgerald (C.), Squirrels in Winter, 136
- Fitzgerald (Prof. G. F., F.R.S.), the Driving of Electro-magnetic Vibrations by Electro-magnetic and Electrostatic Engines, 358; Value of Useless Studies, 392; and the Functions of Universities, 513; M. Poinscaré and Maxwell, 532
- Fitzgerald (Prof. M.), the Flexure of Long Pillars under their own Weight, 479
- Fixation of Free Nitrogen, Results of Experiments at Rothamsted on the Question of the, Dr. J. H. Gilbert, F.R.S., 32
- Fizeau (M.), Measurement of Solar Prominences, 422
- Flame Coloration. Origin of Prof. Smithell's, 306
- Flames, on an Optical Proof of the Existence of Suspended Matter in, Sir G. Stokes, F.R.S., 133
- Flammarion (Camille), Copernic et la Découverte du Système du Monde, 77
- Flett (John S.), the Darwinian Society, 104
- Florence, the Sanitary State of, 19
- Florida, Opening of a Burial Mound in, C. B. Moore, 567
- Flower (William Henry, F.R.S.), the Horse, a Study in Natural History, 436
- Flowers, Travels of a Painter of, 602
- Foerste (A. S.), Relationship of Autumn- to Spring-Blossoming Plants, 478
- Foerster (Dr.), New Compounds of Carbonyl Platinum Chloride and Bromide with Ammonia Derivatives, 236
- Fog in London, 1871-90, the Prevalence of, F. J. Brodie, 215
- Fogs, Effect of, on Plants grown in the Houses at Kew, W. Watson, 16
- Fogs, Town, and their Effects, 53; Dr. W. J. Russell, F.R.S., 10
- Foot as a Prehensile Organ in Hindoos, the, F. Regnault, 192
- Footprints, supposed Human, on Æolian Rocks at Warrnambool, 115
- Foots (Prof. A. E.), a New Locality for Meteoric Iron, with a Preliminary Notice of the Discovery of Diamonds in the Iron, 178
- Forbes (Prof. Henry O.): Evidence of a Wing in *Dinornis*, 257; New Extinct Rail, 416; on a Recent Discovery of the Remains of Extinct Birds in New Zealand, 416; Aphanapteryx in the New Zealand Region, 580
- Forel (Prof. F. A.), the Recent Earthquake in Japan, 199
- Forestry in America, Prof. W. R. Fisher, 611
- Forestry in India, Government, Dr. Ribbentrop, 41
- Fossil Birds in the British Museum, Catalogue of, Richard Lydekker, 33
- Fossil Fauna in Central Iowa, C. R. Keyes, 208
- Fossil Lepidodendrons, on the Discovery of Two Specimens of, in the Neighbourhood of Bathurst, New South Wales, W. J. C. Ross, 424
- Fossil Ornithology: Aphanapteryx in the New Zealand Region, Prof. Henry O. Forbes, 580
- Fossil Ungulates, Aberrant, of South America, 608
- Fossils recently discovered near Boston, Warren Upham, 622
- Foster (Michael), proposed Portrait of, 18
- Foster (W.), the Carbon deposited from Gas Flames, 525
- Fowler (A.), Telescopic Objectives, 204; the Draper Catalogue of Stellar Spectra, 426
- Foxes, California, Prof. Edward S. Holden, 8
- France: Learned Societies in, 20; Les Coquilles Marines des Côtes de France, A. Locard, 219; Earthquake in, 304
- Franchimont (M.), Ethylaldehyde, 576
- Francis (Gerald B.), Double Orange, 534, 607
- Frank (Herr von), Cause of Floating of Particles of Cloud or Fog, 259
- Frankfort International Electrical Exhibition, some Notes on the, 54, 105
- Frankland (Prof. Percy F., F.R.S.), an Elementary Hand-book on Potable Water, Floyd Davis, 25
- Frankland (P. F.), a Pure Fermentation of Mannitol and Dulcitol, 383
- Fream (Dr. W.), Elements of Agriculture, 388
- French (C.), Hand-book of the Destructive Insects of Victoria, 246
- Freshwater and Terrestrial Fauna of Tasmania, Prof. W. Baldwin Spencer, 425
- Frew (W.), a Pure Fermentation of Mannitol and Dulcitol, 383
- Fridlander (E. D.), a Lecture Experiment in Surface Tension, 463
- Friend (Rev. Hilderic), a Rare British Earthworm, 365
- Friswell (R. G.), the Action of Dilute Nitric Acid on Coal, 383
- Fritz (Dr. Adolf), the Fauna of Yezo, 89
- Frog, Discovery of New Species of, in New Jersey, 208
- Frogs, a Plague of Small, R. Haig Thomas, 8; Lieutenant B. A. Muirhead, 30
- Fruit Culture, Practical, J. Cheal, 579
- Fruit-growers' Conference at Sydney, 420
- Function of a University, the, Prof. W. E. Ayerton, F.R.S., 439
- Functions of Universities, Prof. Geo. Fras. Fitzgerald, F.R.S., 513
- Fungi, British Edible, M. C. Cooke, 75
- Fungi, British: Phycomyces and Ustilagineæ, G. Massee, 411
- Furniture Woods, D. Denning, 459
- Fuzziness of some Variable Stars, Cuthbert G. Peek, 497
- Gadolina, Molecular Weight of, 237
- Gale of November 11, the Severe, Chas. Harding, 181
- Game, Big in India, Harold Littledale, 158
- Gangee (John), Superheated Steam, 438
- Gases under the Electric Discharge, Heat Radiation of various Rarefied Gases, Herr Ångström, 306
- Gases, Experiments on Cause of Emission of Light of, Dr. Pringsheim, 312
- Gases and Vapours, on the Virial Equation for, Prof. P. G. Tait, 199
- Gasparis (Prof. Annibale de), Death and Obituary Notice of, 612
- Gas, Proposed Standard, G. Johnstone Stoney, F.R.S., 598
- Gautier (A.), Fixation of Nitrogen by Arable Soils, 192
- Gautier (G.), Medical Utilization of Alternating Currents of High Potential, 456
- Gautier (H.), the Direct Combination of Metals with Chlorine and Bromine, 47
- Geikie (Sir Archibald, F.R.S.), Outlines of Field Geology, Prof. A. H. Green, F.R.S., 97; Volcanic Action in the British Isles, 398
- Gems, Precious Stones and their History, Sources, and Characteristics, Edwin W. Streeter, 531

- Geneva, Temperature Observations at, M. Chaix, 304
- Genoa, Botanical International Congress to be held at, in connection with Celebration of Quatercentenary of Discovery of America by Columbus, 545
- Genvesse (M.), New Mode of Synthesizing Tartaric Acid, 472
- Geodeny, New Mode of Measurement of Perpignan Base, General Derrecgaix, 384
- Geodetic Bureau of Vienna, the Government and the International, 495
- Geography: M. Grum-Grzimalo's Journey to Central Asia, 40; Tibet Expedition, General Pevtsoff, 45; the Sierra Leone Anglo-French Frontier Delimitation Commission, 64; Projected East African Expedition by Dr. Oscar Baumann, 65; Mr. and Mrs. Littledale's Journey across the Pamirs, 90; the Land of the Lamas, William Woodville Rockhill, 98; the Physical Geology and Geography of Ireland, Edward Hull, F.R.S., 102; the Ouse, A. J. Taylor, 102; Geographical Nomenclature, 115; Delagoa Bay, Rosa Monteiro, 124; Carl Humboldt's Explorations in Northern Mexico, 136; the Eastern Taurus and the Anti-Taurus, D. G. Hogarth, 138; Reported Discovery of Ultimate Source of the Nile, 154; the Royal Geographical Society's System for Spelling Geographical Names, 183; Proposed Expedition for Relief of Lieutenant Peary, 183; Orthography of Geographical Names, 186; Korea, Chas. W. Campbell, 307; Expedition to Explore the Glaciers of the Karakoram Range, 279; Formation of Crimean Alpine Club, 349; the Gran Chaco, J. G. Kerr, 351; Journeys in the Pamirs and Adjacent Countries, Captain Younghusband, 353; the Zimbabwe Ruins, Theodore Bent, 402; Captain Pasco on Early Discoveries in Australia, 425; Dr. Murray on Mr. Lindsay's Expedition in Western Australia, 425; J. P. Thomson on Recent Explorations and Discoveries in British New Guinea, 425; the Advanced Class-book of Modern Geography, W. Hughes and J. Francon Williams, 460; the Position of Mount St. Elias, Israel C. Russell, 472; Mr. Alexander Ross's Journey to Head Waters of the Ecayali, Central Peru, 519; Travels among the Great Andes of the Equator, Edward Whymper, Prof. T. G. Bonney, F.R.S., 561; Handy Atlas of Modern Geography, 605; Captain Bower's Journey from China to Simla, 615; Lieutenant Vedel on the Polynesians, 615; Branch of Royal Scottish Geographical Society Established in London, 544; Captain Dundas's Expedition to Mount Kenia, Ernest Gedge, 566
- Geology: Geological Photographs, 64; Annals of British Geology, 1890, J. F. Blake, 77; Geological Society, 94, 165, 263, 287, 359, 453, 525, 597; Geological Society Medals, 257; Geological Society, Election of Officers, 402; *Dacrytherium ovatum*, R. Lydekker, 94; Supplementary Remarks on Glen Roy, T. F. Jamieson, 94; Outlines of Field Geology, Sir Archibald Geikie, F.R.S., Prof. A. H. Green, F.R.S., 97; the Physical Geology and Geography of Ireland, Edward Hull, F.R.S., 102; Geology of Lake Winnipeg, J. B. Tyrrell, 115; the Tertiary Silicified Woods of Eastern Arkansas, R. Ellsworth Call, 119; Pfaff's Allgemeine Geologie als Exakte Wissenschaft, J. Joly, 126; New Railway from Upminster to Romford, Essex, T. V. Holmes, 151; Comparison of South Devon Coast Red Rocks with those of Midland and Western Counties, Prof. Edward Hull, F.R.S., 165; High Level Glacial Gravels near Oswestry, A. C. Nicholson, 165; Geology of Pantelleria, G. Jervis, 207; Geology of New Guinea, R. L. Jack, 209; Geological Excursion in Maryland, a Prof. G. H. Williams, 235; Formation of Cordierite in Sedimentary Rocks pushed by Coal Fires, A. Lacroix, 240; Gravels South of the Thames, from Guildford to Newbury, H. W. Monckton, 263; Fresh Evidence concerning the Distribution of Arctic Plants during the Glacial Epoch, Dr. A. G. Nathorst, 273; the Geology of the Himalayas, 308; Theory of an Interglacial Submergence in England, G. F. Wright, 310; the Permian of Texas, R. S. Tarr, 310; Relation of Melting-Point to Pressure in Igneous Rock Fusion, C. Barus, 311; Cirques, Prof. G. Frederick Wright, 317; Prof. Israel C. Russell, 317; Prof. T. G. Bonney, F.R.S., 391; Note on Specimens of Rock Exposed to High Temperatures, Prof. T. G. Bonney, 357; the Hornblende-Schists, Gneisses, and other Crystalline Rocks of Sark, Rev. Edwin Hill and Prof. T. G. Bonney, 359; the Plutonic Rocks of Garabul Hill and Meall Breac, Dakyns and Teall, 360; the Cause of an Ice Age, Sir Robert S. Ball, F.R.S., 365; Prof. G. H. Darwin, F.R.S., 289; Henry Howorth, 440; the Sponge Remains in Lower Tertiary Strata, near Oamaru, New Zealand, Hinde and Holmes, 384; Report on the Scientific Results of the Voyage of H.M.S.  *Challenger*  during the years 1873-76, Prof. John Judd, F.R.S., 409; Geologists' Association Proposed Excursion to Hornchurch, 420; Geology of Ohio, in connection with the average yield of Wheat, 420; the Stratigraphic Position of the Bear River Formation, T. W. Stanton, 450; the Raised Beaches and Rubble-Drift of the South of England, Joseph Prestwich, F.R.S., 453; the *Olenellus*  Zone in the North-West Highlands, B. N. Peach and J. Horne, 453; the Pleistocene Deposits of the Sussex Coasts, Clement Reid, 454; the Basal Conglomerate of Howth, Prof. Sollas, F.R.S., 455; the Variolite of Annalong, County Down, Prof. G. A. J. Cole, 455; Proposed Austrian Geological Expedition to Central Himalayas, 495; the North-West of England Boulder Committee, 495; Striated Surface under the Cromer Drift, William Sherwood, 511; the Part played in the Growth of Geological Opinion by Regions near great Universities, Prof. G. H. Williams, 519; New Railway Cutting between Upminster and Romford, T. V. Holmes, 525; Drift Beds of North and Mid Wales Coasts, T. M. Keade, 525; the Alleged Submergence in Scotland during the Glacial Epoch, Dugald Bell, 527; Testimonial to Mr. W. H. Hudleston, F.R.S., by the Geologists' Association, 544; Mr. A. S. Woodward appointed Assistant-Keeper of Geological Department at the British Museum, 566; on the Microscopic Structure and Residues Insoluble in Hydrochloric Acid in the Devonian Limestone of South Devon, Edward Wethered, 597; Rocks Collected by M. Lopatin on the Podkamennaya Tunguska, 597; Geology of the Gold-bearing Rocks of the Southern Transvaal, Walcot Gibson, 598; the Precipitation and Deposition of Sea-borne Sediment, R. G. Mackley Browne, 598
- Geometry: Prof. Kikuchi's Treatise on, 20; Euclid's Elements of Geometry, A. E. Layng, 149; Non-Euclidian Geometry, Prof. H. Poincaré, 404; a Treatise on the Geometry of the Circle, and some Extensions to Conic Sections by the Method of Reciprocation, W. J. McClelland, 412; a Defect in the Oxford Pass Examination Papers, 443
- Gedge (Ernest), Captain Dundas's Expedition to Mount Kenia, 566
- German Anthropological Society, 39
- German Mathematical Association, 278
- German Technology for English Manufacturers, Prof. T. E. Thorpe, F.R.S., 121
- Germany and Austria, Health Springs of, Dr. F. O. Buckland, 510
- Germany, Workmen Killed and Wounded in Accidents in, M. Vacher, 350
- Giard (Prof. A.), a New Case of Mimicry, 379
- Gibson (Dr.), Rules for Determining whether a given Benzene Mono-Derivative shall give a Meta-di-derivative or a Mixture of Ortho- and Para-di-derivatives, 525
- Gibson (Walcot), Geology of the Gold-bearing Rocks of the Southern Transvaal, 598
- Gifford (W.), the Resolution of *Amphipleura pellucida*, 143
- Gilbault (Henri), New Condensation Hygrometer, 288
- Gilbert (Dr. J. H., F.R.S.), Results of Experiments at Rothamsted on the Question of the Fixation of Free Nitrogen, 32
- Gill (D.), Photography at the Cape Observatory, 600
- Ginger-beer Plant, the, Prof. H. M. Ward, F.R.S., 190
- Giraffe at the Zoological Gardens, the Death of the, 518
- Giraffes, 585
- Glacial Epoch, Fresh Evidence concerning the Distribution of Arctic Plants during the, Dr. A. G. Nathorst, 273
- Glacial Period, the Astronomical Theory of the, Sir Robert Ball, F.R.S., Prof. G. H. Darwin, F.R.S., 289
- Geologists' Association, the, 495
- Glaciers of the Karakoram Range, Expedition to Explore the, 349
- Glaciers, Measures of Variations in Lengths of Dauphiny, Prince Roland Bonaparte, 576
- Glasgow Geological Society, 527
- Glass, Measurement of Process of Dissolution of, by Change in Electric Conductivity of Water, Herr Pfeiffer, 209
- Glazebrook (R. T.), some Notes on Clark's Cells, 47
- Globe, a new Precessional, Dr. K. Haas, 250
- Godman (F. D., F.R.S.), Presidential Address to Entomological Society, 359
- Godwin-Austen (Mrs. Jessie), a Swan's Secret, 416
- Goiran (A.), Earthquakes and Vegetation, 478, 520
- Gold-bearing Rocks of the Southern Transvaal, Geology of the, Walcot Gibson, 598

- Gonimophyllum Buffhami*, a new Marine Alga, E. A. L. Batters, 590
- Gonner (E. C. K.), Ricardo's Principles of Political Economy and Taxation, 4
- Goodale (Prof.), Botanical Museums and Gardens of Australasia, 65
- Goode (G. B.), Museums of the Future, 421
- Gooseberries, the Prolongation of the Season for, D. Thomson, 157
- Gordyaghin (A.), Biology of the Sunflower, 597
- Gore (J. Ellard): Star Groups, 52; Observations of  $\mu$  Cephei, 137
- Gore (Dr. G., F.R.S.), Relation of Voltaic Electromotive Force to Molecular Velocity, 596
- Goschen (Right Hon. G. J.), on the Use of the Imagination, 87
- Goss (H.): the New Forest Bill, 1892, 295; the New Forest in Danger, 343
- Gothard (Herr), New Star in Auriga, 473
- Gould (Dr. B. A.), Variation of Latitude, 521
- Gouy (M.), Electro-capillary Phenomena and Differences of Potential produced by Contact, 264
- Grafted Plants, W. H. Beeby, 151
- Grafts and Heredity, Prof. George Henslow, 198
- Grain-production of Russia, the, M. Borkovsky, 67
- Gran Chaco, the, J. G. Kerr, 351
- Granger (F. S.), Psychology, a Short Account of the Human Mind, 76
- Grant (Col. J. A.), Obituary Notice of, 376
- Grantham (R. B.), Obituary Notice of, 183
- Grape-culture in Ontario, 209
- Grasses of the South-West, Dr. George Vasey, 390
- Gravitation, a Theory of, 100
- Gray (Prof. A.): Electricity and Magnetism by Amédée Guillemin, 1; Electro-Magnetism, S. P. Thompson, F.R.S., 73; Electrodynamical Theories and the Electromagnetic Theory of Light, M. Poincaré, 367
- Gray (Dr. Elisha), on the International Congress of Electricians to be held at Chicago, 19
- Gray (J. Macfarlane), Superheated Steam, 413, 486
- Great Bower Bird, Depredations of, in the Queensland, 588
- Greece: Earthquakes in, 259; Forest Land in, 588
- Greek Literary Style, on the most Recent Phases of, Prof. Blackie, 624
- Greely (General), International Monthly Charts of Mean Barometric Pressures and Wind Directions, 350
- Green (A. G.), Ortho- and Para-nitro-ortho-toluidine, 92
- Green (Prof. A. H., F.R.S.), Outlines of Field Geology, Sir Archibald Geikie, F.R.S., 97
- Green (G. C.), Tame Jackdaws, 545
- Green (W. Edridge), Colour Blindness and Colour Perception, 195
- Grenfell (J. G.), the Occurrence of Pseudopodia in Diatomaceous Genera *Melosira* and *Cyclotella*, 140
- Greenhill (Prof. A. G., F.R.S.), Thermodynamics of the Steam Engine and other Heat Engines, Cecil H. Peabody, 172
- Greenhill (Prof., F.R.S.), Rectification of the Cartesian Oval, 503
- Greenland, Angelo Heilprin on Summer Tour to, 88
- Greenland, proposed Expedition for relief of Lieut. Peary, 183
- Gregory (J. W.): *Archaopneustes abruptus*, a new Echinoid from Barbados, 287; the Tudor Specimen of Eozoon, 486
- Grensted (Rev. Fred. F.), Orientation of Ancient Monuments, 464
- Gresham College, Lectures on the Eye at, 586
- Gresham University, the Proposed, 323, 442, 517; Bedford College and the, Dr. W. J. Russell, F.R.S., Lucy J. Russell, 391
- Grevy's Zebra, Skin of, brought from Somaliland, 598
- Griffiths (A. B.), Pomaines Extracted from Urine in some Infectious Maladies, 72
- Griffiths (Dr.), *Bacterium Allii*, 624
- Gross (Dr.), Decomposition of Sulphur tested Electrolytically, 599
- Growth of the Pilchard or Sardine, Prof. J. T. Cunningham, 255
- Grum-Grzimalo's (M.) Journey to Central Asia, 40
- Guardafui, Cape, and the Neighbouring Sea, 36
- Guatemala, the Climate of Alta Verapaz, Dr. Sapper, 41
- Gude (G. K.), Peculiar Eyes, 151
- Guillemin (Amédée), Electricity and Magnetism, Prof. A. Gray, 1
- Gulbenkian (Calouste S.), La Transcaucasie et la Péninsule d'Achéron, 52
- Gumlich (Dr.), on the Urinary Excretion of Nitrogen, 599
- Guns: Calculation of Trajectories of Elongated Projectiles, Rev. F. Bashforth, 473
- Guntz (Dr.), Action of Carbon Monoxide on Iron and Manganesian, 311
- Guye (Dr. P. A.), the Various Forms given to the General Equation expressing Behaviour of Liquids and Gases under Different Conditions of Volume, Temperature, and Pressure, 142
- Haarlem, Prize Subjects proposed by Dutch Academy of Sciences, 37
- Haas (Dr. K.): Mental Arithmetic, 198; a New Precessional Globe, 250
- Haeckel (Prof. Ernst), Anthropogenie oder Entwicklungsgeschichte des Menschen, 482
- Haerdtl (Dr. G. F.), Winnecke's Comet, 617
- Hainan, 286
- Hale (Prof.): the Aurora Spectrum, 522; Solar Investigation, 473; Solar Prominence Photography, 326
- Halliburton (R. G.), the Dwarfs of Mount Atlas, 66
- Hall (Prof. A.), the Relative Motion of 61 Cygni, 547
- Hall (Maxwell), Rainfall Atlas of Jamaica, 324
- Haller (A.), Researches in Ethyl Monochlor-, Monobrom-, and Monocyanacetates, 432
- Halliburton (W. D.), a Text-Book of Chemical Physiology and Pathology, Dr. E. H. Starling, 51
- Halske and Siemens, Experiments on the Production of Ozone by Electric Silent Discharge, 39
- Hamburg (Dr. H. E.), Radiation of Upper Cloud round Barometric Minima, 156
- Hamilton (W. B. Lefroy), Working of the Search Light, 587
- Hamlet (W. M.), on the Progress of Chemistry in Australasia, 423
- Hampson (G. F.), Stridulation in certain Lepidoptera, 503
- Hann (Dr. J.), Meteorological Observations at Cairo, 1868-1888, 156
- Harding (Chas.), the Severe Gale of November 11, 181
- Harley (Dr. Vaughan), Note on the Behaviour of Sugar in Blood, 407
- Harmer (S. F.), the Excretory Process in Marine Polyzoa, 480
- Harries (H.), the Origin of Influenza Epidemics, 431
- Harrison (W. Jerome), Guide to the Examinations in Chemistry, 342
- Harrington (Mark W.), United States Weather Bureau, 86
- Harrow Birds, G. E. H. Barrett-Hamilton, 342
- Hart (J. H.), a New West Indian Form of *Agave rigida*, 445
- Harting (J. E.), Ornithology of the Sandwich Isles, 532
- Hartlaub (Dr. Clemens), 544
- Hartley (W. N.), the Acid Action of Drawing-papers, 43c, 453
- Hartmann (Dr.), Increase of the Earth's Shadow during Lunar Eclipses, 498
- Hartnup (John), Death of, 612
- Hartog (Prof. Marcus), a Difficulty in Weismannism, 102
- Harvard University, Remarkable Development of Botanical Establishment of, by the Munificence of Prof. G. L. Goodale, 545
- Haupt (Prof. L. M.), Proposed Ship Canal between New York and Philadelphia, 497
- Hauser (J.), a Study of the Velocity of Decomposition of Diazo-Compounds by Water, 480
- Hayden (Everett), the Samoan Hurricane, 461
- Hayward (Robert B., F.R.S.): the Salts in Natural Waters, 176; on the Variation of Latitude, 465
- Hazen (Prof.), High Balloon Voyages, 189
- Hazen (Prof. H. A.), Wind-rush at Washington, 597
- Health Springs of Germany and Austria, Dr. F. O. Buckland, 510
- Health Resorts, Value of Meteorological Instruments in Selection of, Dr. C. Theodore Williams, 551
- Heat, Theory of, J. Clerk Maxwell, 222
- Heat-radiation of various rarefied Gases under the Electric Discharge, Herr Ångström, 306
- Heat: the Thermal Conductivities of Crystal and other Bad Conductors, C. H. Lee, 382
- Heat, Solar, Dr. Joseph Morrison, 589
- Heat-Engine, a Simple, Fred. J. Smith, 294; Prof. Konstantin Karamate, 416; Nickel, W. B. Croft, 392

- Heat-Engines and Saline Solutions, Lord Rayleigh, F.R.S., 438, 510  
 Heath (Thos.), a Brilliant Meteor, 295  
 Hector (Sir James), Mr. Albert Koebele and the Enemies of Insect Pests, 65  
 Heider (Dr. K.), Lehrbuch der vergleichenden Entwickelungsgeschichte der Wirbellosen Thiere, 145  
 Heilprin (Angelo), on a Summer Tour to Greenland, 88  
 Held (A.), Researches on Ethyl Monochlor-, Monobrom-, and Monocyanacetacetate, 432  
 Heligoland, the New Imperial German Zoological Station at, 544  
 Hellmann (Prof.), the First Balloon Voyage for Scientific Purposes, 471; Experiments on Rainfall Records, 545  
 Hellebore as an Insecticide, W. W. Smith, 546  
 Helmholz (Prof. von), Celebration of His Seventieth Birthday, 18  
 Hemsley (W. Botting, F.R.S.): Biology of Seaside Plants, 3; Botanical Nomenclature, Dr. Otto Kuntze, 169  
 Henslow (Rev. Prof.), a Theory of Heredity based on Forces, 93  
 Henslow (Prof. Geo.), Grafts and Heredity, 198  
 Herbarium Pest, a New, Dr. C. V. Riley, 235  
 Heredity, Grafts and, Prof. Geo. Henslow, 198  
 Heredity, a Theory of, based on Forces, Rev. Prof. Henslow, 93  
 Héricourt (J.), the Tubercular Vaccination of the Dog, 576  
 Hering on the "Valence" of a Coloured Radiation, 115;  
 Heron, Taming a, Colonel W. S. Hore, 588  
 Herroun (Prof.), Electromotive Forces of Gold and Platinum Cells, 574  
 Hesehus (Herr), Refraction and Velocity of Sound in Porous Bodies, 156  
 Heurtault (M.), the Tides of the Bay of St. Malo, 143  
 Heycock (C. T.), the Change of Zero of Thermometers, 526  
 Hibbert (W.), a Permanent Magnetic Field, 191  
 Hicks (Dr. H., F.R.S.), Discovery of Remains of Prehistoric Animals in Endsleigh Street, 566  
 Hickson (Dr. S. J.): the Medusæ of *Millepora Murrayi* and the Gonophores of *Allopora* and *Distichopora*, 140; the Hydrocoralline collected by Prof. Haddon in Torres Straits, 407; Anatomy and Habits of Alcyonium, 455  
 High Temperature, Metals at, Prof. W. C. Roberts-Austen, F.R.S., 534  
 Hill (Rev. Edwin), the Hornblende-Schists, Gneisses, and other Crystalline Rocks of Sark, 359  
 Hill (Prof. M. J. M.), the Loci of Singular Points and Lines occurring in connection with the Theory of Locus of Ultimate Intersections of a System of Surfaces, 141  
 Hillebrand (W. F.), New Analysis of Uraninite, 119  
 Hills, Story of the, Rev. H. N. Hutchinson, 364  
 Himalayas, the Geology of the, 308  
 Himalayas, Proposed Austrian Geological Expedition to Central, 495  
 Hinde (G. J.), the Sponge Remains in Lower Tertiary Strata, near Oamaru, N.Z., 382  
 Hindoos, the Foot as a Prehensile Organ in, F. Regnault, 192  
 Hindu Period in Java, Relics of, 88  
 Himmel und Erde, 237, 568  
 Hinsdale (E. B.), the Historic Copper Mines on Lake Superior, 39  
 Hirst (Dr. Thos. Archer), Obituary Notice, 399  
 Hitchcock (Prof.), Ancient Tombs and Burial Mounds of Japan, 381  
 Hobart (J. F.), the Paper-making Industry in the United States, 279  
 Hobson (Bernard), Ice Crystals, 365  
 Hobson (E. W.), Harmonic Functions for the Elliptic Cone, 335  
 Hodgkins (Mr. Thos.), Gift to Smithsonian Institution by, 37  
 Hodgkinson (W. R.): New Method of Preparing  $\beta$ -dinaphthylene Oxide, 93; Action of Sodium on Etheral Salts, iii., Benzyl Orthotoluate, 214; Ethyldimethylamidobenzene, 551  
 Hoffmann (Dr. H. K. H.), Death of, 18  
 Hogarth (D. G.), the Eastern Taurus and the Anti-Taurus, 138  
 Holten (Prof. Edward S.): California Foxes, 8; the Discovery of Neptune, 522; Influenza in America, 582  
 Hollis (W. Ainslie), on the Relation of Natural Science to Art, 319  
 Holmes (T. V.), New Railway from Upminster to Romford, Essex, 151, 525  
 Holmes (W. M.), the Sponge Remains in Lower Tertiary Strata near Oamaru, N.Z., 384  
 Holt (E. W. L.): Rarer Shore and Deep-Sea Fishes obtained during *Harlequin* Cruise on West Coast of Ireland (1891), 167; Destruction of Immature Sea Fish, 249  
 Homing Pigeons, Utilization of, W. B. Tegetmeier, 320  
 Hoogewerff (S.), Action of Aqueous Solution of Ammonia on Phthalic Chloride, 72  
 Hooker's *Icones Plantarum*, third series, 86  
 Hopkins (F. Gowlan): Pigment in Yellow Butterflies, 197; Pigments of Lepidoptera, 581  
 Hopkinson (John), the Water-Supply of London, 88  
 Hore (Col. W. S.), Taming a Heron, 588  
 Horizon, Apparent Size of Objects near the, T. W. Backhouse, 7  
 Hornchurch, Proposed Excursion of Geologists' Association to, 420  
 Horne (J.), the Olenellus Zone of the North-West Highlands, 453  
 Horology, the Use of a Free Pendulum as a Time Standard, T. C. Mendenhall, 450  
 Horse Doctor, Mayhew's Illustrated, 27  
 Horse, the, a Study in Natural History, William Henry Flower, F.R.S., 436  
 Horticulture: the Place of Horticulture in Technical Education, W. Wilks, 38; Olive Culture in Australia, Principal J. L. Thomson, 135; Horticulture in South Australia, 184; Experimental Perfume Farming in Victoria, 305; Instruction in, W. T. Thiselton Dyer, 402; Proposed Exhibition for the Development of, 613  
 Hose's (Charles) Collections, 517  
 Houses of Parliament, Examination of the Standards of Measure and Weight immured in the, 534  
 Howarth (Henry H.), Sir R. Ball's Cause of an Ice Age, 440  
 Hubbard (Gardiner G.), Evolution of Commerce, 588  
 Hubrecht, Placentation of certain Lemurs and Insectivora, 600  
 Hudleston (W. H., F.R.S.), Presentation of Testimonial of Geologists' Association to, 544  
 Hudson (Miss Hilda), Simple Proof of Euclid II. 9 and 10, 189  
 Hudson (W. H.), the Naturalist in La Plata, Dr. Alfred R. Wallace, 553  
 Hudspeth (R. N.), Auroras at Toronto, 7  
 Hughes (R. E.), Action of Dry Hydrochloric Gas on Dry Carbonates, 503  
 Hughes (William) and J. Francon Williams, the Advanced Class-book of Modern Geography, 460  
 Hull (Prof. Edward, F.R.S.): the Physical Geology and Geography of Ireland, 102; Comparison of the South Devon Coast Red Rocks with those of Midland and Western Counties, 165  
 Human Footprints on the Rocks at Warrnambool, 115  
 Human Physiology, an Introduction to, Augustus D. Waller, Dr. E. H. Starling, 340  
 Hunfalvy (Paul), Death and Obituary Notice of, 207  
 Hunt (A. E.), the Manufacture and Use of Aluminium from an engineering point of view, 568  
 Hunt (A. R.), the Formation and Erosion of Beaches, 415  
 Hunt (Dr. T. Sterry), Obituary Notice of, W. Topley, 400  
 Hurricane, the Samoan, Everett Hayden, 461  
 Hurter (F., Ph.D.), and George Lunge, Ph.D., the Alkali-Maker's Hand-book, Prof. T. E. Thorpe, F.R.S., 121  
 Hutchinson (Rev. H. N.), Story of the Hills, 364  
 Hutton (Prof.), on the Origin of the Struthious Birds of Australasia, 425  
 Huxley (T. H.), La Place de l'Homme dans la Nature, 197  
 Huygens (Christiaan), *Cœuvres Complètes de*, A. M. Clerke, 434  
 Hyades (P.), and J. Deniker, *Mission Scientifique de Cap Horn*, 577  
 Hydrodynamics: Experiments in Aërodynamics, Lord Rayleigh, F.R.S., 108  
 Hydrogen and Oxygen, Silent Combination of, Prof. Victor Meyer and Herr Askenasy on, 616  
 Hydrography: Austrian Government Deep Sea Explorations in Eastern Mediterranean, 518  
 Hydrostatics, Method of Experimental Proof of Principle of Archimedes, M. Paquet, 209  
 Hydroxylamine, Free, Isolation of, 20  
 Hygiene of Water-Supply, Floyd Davis, Prof. Percy F. Frankland, F.R.S., 25  
 Hygienic Congress: Dr. W. J. Russell, F.R.S., on Town Fogs and their Effects, 10  
 Hygrometer, New Condensation, Henri Gilbault, 288

- Hylo-Idealism, 389  
 Hypsometry, the Aneroid in, Edward Whympcr, 339; Herbert Tomlinson, F.R.S., 440
- Ice, a Tortoise inclosed in, Frank Finn, 320  
 Ice Age, the Cause of an, Sir Robert Ball, F.R.S., 365; Prof. G. H. Darwin, F.R.S., 289; Henry H. Howorth, 440  
 Ice Age of America, Prof. G. Frederick Wright, 317; Prof. Israel C. Russell, 317  
 Ice Crystals, Gilbert Rigg, 319; Bernard Hobson, 365  
*Iceberg purchased at St. Helen's*, 115  
 Ichthyology: Destruction of Immature Sea-Fish, Alfred O. Walker, 176; Ernest W. L. Holt, 249; Marine, Rarer Shore and Deep Sea Fishes obtained during the *Harlequin* Cruise on West Coast of Ireland, 1891, E. W. L. Holt, 167; the Lateral Sense-Organs of Elasmobranchs, 239; the Electric Organ of the Skate, Prof. J. G. Ewart, 451; Pilchards, Matthias Dunn, 511  
 Ilford Manual of Photography, C. H. Bothamley, 460  
 Imagination, the Use of the, Rt. Hon. G. J. Goschen, 87  
 Immature Sea-Fish, Destruction of, Alfred O. Walker, 176; Ernest W. L. Holt, 249  
 Implications of Science, Dr. St. George Mivart, F.R.S., 60, 82, 223, 343; Edward T. Dixon, 125, 272, 391; Miss E. E. C. Jones, 223, 366  
 Incandescent Iron, First Visible Colour of, Capt. A. Noble, F.R.S., 484; T. C. Porter, 558  
 India: Government Forestry in, Dr. Ribbentrop, 41; Catalogue of Mammalia in the Indian Museum, Calcutta, W. L. Slater, 50; Meteorological and Physical Atlas of the Indian Ocean, 101; the Publications of the Meteorological Department of India, 113; Report on the Meteorology of India in 1889, John Eliot, 217; Reports on the Administration of the Meteorological Department of the Government of India, 217; Beast and Man in India, John Lockwood Kipling, 131; Strange Symbolical Marriage Custom in India, Dr. Post, 135; Big Game in India, Harold Littledale, 158; List of the Snakes in the Indian Museum, W. L. Slater, 817; Rain and Mildew in India, Dr. A. Barclay, 477; the Winter Storms of Northern India, Henry F. Blanford, F.R.S., 490; the Wild Silk Insects of India, E. C. Cotes, 520; Agricultural Needs of India, 588  
 India-rubber, the Solution of Vulcanised, Carl Barus, 118  
 Indians: North American, Exhibit at Chicago Exhibition, 184; Prints of Havesu-paio Indians, Dr. Shufeldt, 235; the Ceremonial Circuit of the Cardinal Points among the Tusayan Indians, J. W. Fewkes, 546  
 Indo-China, Proposed Expedition of Dr. H. Jagor to, 258  
 Indonesia, Use of the Sumpitan and Bow in, C. M. Pleyte, 235  
 Industrial Organic Chemistry, Samuel P. Sadtler, 125  
 Inertia, Force of, the Terms Centrifugal Force and, George S. Carr, 463  
 Infectious Diseases, a Study of Influenza and the Laws of England concerning, R. Sisley, 556  
 Influenza in America, Prof. Edward S. Holden, 582  
 Influenza Bacillus, Reported Discovery of, 250; Dr. Richard Pfeiffer, 233  
 Influenza Epidemics, the Origin of, H. Harries, 431  
 Influenza, a Study of, and the Laws of England concerning Infectious Diseases, R. Sisley, 556  
 Ingle (H.), Structure and Chemistry of Flames, 214  
 Inheritance of Acquired Characters, Alfred W. Bennett, 53  
 Insect Colours, F. H. Perry Coste, 513, 541  
 Insect Pests, C. French, 246  
 Insecticide, Hellebore as an, W. W. Smith, 546  
 Insectivora, Placentation of certain Lemurs and, Hubrecht, 600  
 Insectivorous Plants, R. Lindsay, 157  
 Institution of Civil Engineers, 37  
 Institution of Electrical Engineers, 155  
 Institution of Mechanical Engineers, 22, 355, 585  
 Institution of Naval Architects, 570  
 Instruments, the Bow as Origin of Stringed, Dr. E. B. Tylor, 184  
 Intelligence in Birds, A. Wilkins, 151, 177  
 International Sanitary Conference, 233  
 Intracranial Circulation and its Relation to the Physiology of the Brain, James Cappie, M.D., 26  
 Iowa, Central, Fossil Faunas in, C. R. Keyes, 208
- Ippoh Poison of the Malay Peninsula, the, Leonard Wray, Junior, 278  
 Ireland, Free Education in, 403  
 Ireland, the Physical Geology and Geography of, Edward Hull, F.R.S., 102  
 Irish Giant Cornelius Magrath, the Skeleton of the, Dr. D. J. Cunningham, F.R.S., 147  
 Irish Naturalist, the, 567  
 Iron: Iron Carbonyl from Water Gas, A. E. Tutton, 36; some Experiments made with the view of ascertaining the Rate of Propagation of Induced Magnetism in Iron, Fred. T. Trouton, 42; Magnetization of Iron, Prof. C. G. Knott, 431; Iron Production in the United States, Berkeley, 65; Meteoric Iron, E. Cohen, E. Weinschenk, 69; a New Locality for Meteoric Iron, with a Preliminary Notice of the Discovery of Diamonds in the Iron, Prof. A. E. Foote, 178; Action of Water Gas on Iron, Roscoe and Scudder, 92; the Spectrum of Iron and the Periodic Law, John Parry, 253; on the Rusting of Iron, A. Livierside, F.R.S., 424; First Visible Colour of Incandescent Iron, Capt. A. Noble, F.R.S., 484; T. C. Porter, 558; Native Iron of Cañon Diablo, Arizona, M. Mallard, 575  
 Irrigation Canals of Arizona, the Prehistoric, 185  
 Irvine (Robert), Manganese Nodules in the Marine Deposits of the Clyde Sea-area, 527  
 Isothermal Equation, Prof. D. T. Korteweg on Van der Waals's, 152, 277  
 Italy, Earthquakes in, 259  
 Izvestia of the Russian Geographical Society, 92
- Jack (R. L.), Geology of New Guinea, 209  
 Jackdaws, Tame, G. C. Green, 545  
 Jackson (B. Daydon), Index of Genera and Species of Flowering Plants, 39  
 Jagor (Dr. H.), Proposed Expedition to Indo-China, 258  
 Jamaica, Disease among the Cocoa-nut Palms of, 88; Earthquake in, 207; the proposed Columbus Marine Biological Station at, Prof. Ray Lankester, 420  
 Jamieson (T. F.), Supplementary Remarks on Glen Roy, 94  
 Janssen (M.), Presidential Address to French Meteorological Society, 350  
 Japan: Earthquakes in, 19; 86; Effects of Japanese Earthquake of October 28, 1891, 38; Seismometry and Engineering in Relation to the Recent Earthquake in Japan, Prof. John Milne, F.R.S., 127; the Recent Earthquake in Japan, Prof. F. A. Forel, 199; Earthquake-observing Stations in, 471; Avifauna of, 40; Flora of, 40; Tokyo Botanical Magazine, 46; Illustrations of the Flora of Japan to serve as an Atlas to the Nippon-Shokubutsushi, Tomitaro Makino, 149; Annual (1889) Meteorological Report, 184; Proposed Construction of numerous Meteorological Observatories in Japan, 258; the Meteorological Station of Naha, Luku Islands, 597; Science in Japan, Prof. E. Ray Lankester, F.R.S., 256; the English Language in Japanese Schools, 303; the Ancient Tombs and Burial Mounds of Japan, Prof. Hitchcock, 381  
 Java, Relics of the Hindu Period in, 88  
 Jephson (Major I. A. M.), Botany of the Emin Relief Expedition, 9  
 Jervis (G.), Geology of Pantelleria, 207  
 Jeserich (Dr. Paul), Photography applied to the Detection of Crime, 568  
 Joannis (M.): Curious Compound of Lead, Sodium, and Ammonium, 158; some well-defined Alloys of Sodium, 504  
 Johns Hopkins University, Report for 1891, 259  
 Joly (J.): Pfaff's Allgemeine Geologie als Exacte Wissenschaft, 126; a Shutter for Use in Stellar Photography, 167  
 Jones (A. Coppen), Arrow Poison, 343  
 Jones (Miss E. E. C.), Implications of Science, 223, 366  
 Jones (Herbert), the Silchester Remains, 259  
 Jones (T. Wharton, F.R.S.), Death of, 86  
 Journal, a New Astronomical, 307  
 Journal of Botany, 46, 287, 477, 596  
 Journal of the Royal Agricultural Society, 568  
 Judd (Prof. John W., F.R.S.), the October Eruption Northwest of Pantelleria, G. W. Butler, 154; Report on the Scientific Results of the Voyage of H.M.S. *Challenger* during the Years 1873-76, 409  
 Junker (Dr. Wilhelm), Travels in Africa during the Years 1879-83, 507  
 Junker (Dr. Wilhelm), Obituary Notice of, 376



- Jupiter, the Planet, 521; Outburst of Dark Spots on, 41; the Rotation of, A. Belopolsky, 70; W. F. Denning, 473; Jupiter and his First Satellite, E. G. Barnard, 159; Jupiter's Satellites, Measurement of, by Interference, A. A. Michelson, 160; the Red Spot on, W. F. Denning, 272
- Kalm's Account of his Visit to England on his way to America in 1748, 412
- Karakorum Range, Expedition to explore the Glaciers of the, 349
- Karamate (Prof. Konstantin), a Simple Heat Engine, 416
- Karsten (G.), Ueber die Mangrove-Vegetation im Malayischen Archipel, 3
- Kefyr in Use in Canada and United States, Milk-ferment identical with, C. L. Mix, 471
- Kellicott (Dr.), Fresh-water Sponges in the Buffalo Bay and Niagara Region, 305
- Keltie (J. Scott), Statesman's Year-Book for the Year 1892, 437
- Kennedy (Admiral), Sporting Sketches in South America, 390
- Kerr (J. G.), the Gran Chaco, 351
- Kew Bulletin, Proposed Discontinuance of the, 494
- Kew Bulletin: Collection of Dried Plants from the Solomon Islands, 586
- Kew, Effects of Fog on Plants grown in the Houses at, W. Watson, 16
- Kew Gardens, Jubilee of, 378; Collections of Plants at, 586
- Kew Observatory, Two new Forms of Anemometer in use at, 587
- Keys (C. R.), Fossil Fauna in Central Iowa, 208
- Kikuchi (Prof.), Treatise on Geometry, 20
- Kilgour (H.), the Thermal Emisivity of Thin Wires in Air, 162; Interference with Alternating Currents, 238
- Kilima-Njaro District, Discovery of Saltpetre and Soda in, 379
- Kinetic Energy, on the Boltzmann-Maxwell Law of Partition of, Rev. H. W. Watson, F.R.S., 512
- Kipling (John Lockwood), Beast and Man in India, 131
- Kipping (F. S.), Camphore, 263; Production of Ketone 1:2:4-Acetoxythylene from Camphor by Action of Sulphuric Acid and Zinc Chloride, 551
- Kleiber (Dr. J.), Displacement of Radiant Points, 570
- Klein's Modulating Functions, F. N. Cole, 597
- Klinge (Herr), Peat-bog Eruptions, 472
- Klobb (M.), Anhydrous Sulphates of Zinc, Nickel, Copper, and Cobalt obtained in Crystals, 569
- Knott (Prof. C. G.), Magnetization of Iron, 431
- Koebele (Mr. Albert); and the Enemies of Insect Pests, Sir James Hector, 65; *Orcus chalybeus* an important enemy of the Red Scale, 323
- Koh-i-Nur, the, Prof. N. Story Maskelyne, F.R.S., 5; Dr. V. Ball, F.R.S., 126
- König (Prof.), the Curves of Luminosity of Spectral Colours under very feeble Illumination, 432
- Kopp (Prof. Hermann); Death of, 419; Obituary Notice of, Prof. T. E. Thorpe, F.R.S., 441
- Korea, Charles W. Campbell, 307
- Korschelt (Dr. E.), Lehrbuch der Vergleichenden Entwicklungsgeschichte der Wirbellosen Thiere, 145
- Korteweg (Prof. D. J.) on Van der Waals's Isothermal Equation, 152, 277
- Korthals (Dr. P. W.), Death and Obituary Notice of, 377
- Krueger (Prof.), Motions of Periodic Comets, 446
- Krüger (Dr.), Chemical Constitution of Adenin and Hypoxanthin, 168
- Kuntze (Dr. Otto), Revisio Genera Plantarum Vascularium omnium, atque Cellularium Multarum, secundum Leges Nomenclature Internationales, cum Enumeratione Plantarum in Itinere Mundi collectarum, W. Botting Hemsley, F.R.S., 169
- Kurdistan, Journeys in Persia and, Mrs. Bishop, 248
- La Plata, the Naturalist in, W. H. Hudson, Dr. Alfred R. Wallace, 553
- Laboratory at Berlin, Prof. Pictet's, Prof. R. du Bois-Reymond, 31
- Laborde (M.), Arrow-poison of Sarro Savages, 278
- Lachlan (R.), Theorems relating to a Series of Coaxial Circles, 335
- Lachmann (Dr.), Research on Extremes of Temperature in Europe, 576
- Lacroix (A.), Formation of Cordierite in Sedimentary Rocks fused by Coal Fires, 240
- Lacroix (M. A.) on the Relations Existing between the Form and Nature of the Beds of Andalusite at Arriège, 624
- Lagrange et Hoho (E.), Study of Light and Heat Phenomena accompanying Electrolysis, 216
- Lake Superior, Prehistoric Mines on, E. B. Hinsdale, 39
- Lamarck, 1799, "Meretrix," versus "Cytbera," Lamarck, 1806, C. R. Osten Sacken, 30
- Lamas, the Land of the, William Woodville Rockhill, 98
- Lancashire Boilers, Modern, Samuel Boswell, 22
- Landauer (J.), Blowpipe Analysis, 580
- Lang (Arnold), Text-book of Comparative Anatomy, Prof. E. Ray Lankester, F.R.S., 145
- Langley (Prof. S. P.); Smithsonian Standards for Physical Apparatus, 197; Report for the year, Smithsonian Institution, 261
- Lankester (Prof. E. Ray, F.R.S.); Obituary Notice of Henry Nottidge Moseley, F.R.S., 80; Text-book of Comparative Anatomy, Arnold Lang; Lehrbuch der Vergleichenden Entwicklungsgeschichte der Wirbellosen Thiere, Dr. E. Korschelt und Dr. K. Heider, 145; Election to Linacre Professorship of, 183; Science in Japan, 256; the late Dr. Carpenter's Microscope and its Revelations, Seventh Edition, by Rev. W. H. Dallinger, F.R.S., 313; University of London, 413; the proposed Columbus Marine Biological Station at Jamaica, 420; a Zoologist on Disease, Dr. Elie Metchnikoff, 505; Exchange of Professorial Duties, Prof. T. P. Anderson Stuart, 557
- Lapworth (Prof. Charles, F.R.S.), Royal Society Medallist, 111
- Larat (L.), Medical Utilization of Alternating Currents of High Potential, 456
- Larkin (F. Charles), Outlines of Practical Physiological Chemistry, 292
- Larmor (J.); Effect of Flaws on Strength of Materials, 166; Equations of Propagation of Disturbances in Gyrostatically Loaded Media, 214; the Simplest Equivalent of a given Optical Path, 502
- Larynx, the Mechanism of the Closure of the, Prof. T. P. A. Stuart, 357
- Lasne (H.), Barometric Gradients, 350
- Latham (Baldwin); Evaporation and Condensation, 335; Observations on the Flow of Underground Water, 336
- Latitude: the Variation of, 117, 210; Dr. S. C. Chandler, 404; Robt. B. Hayward, F.R.S., 465; Dr. B. A. Gould, 521; M. Faye, 570; Periodic Variations in, Chandler, 589
- Latus (Johann), the Case of, 349
- Lauder (A.), Corydaline, 383
- Laurence (G. F.), a Curious Stone Hammer found in the Thames, 324
- Laurent (Em.), the Fixation of Free Nitrogen by Plants, 143
- Laurie (Malcolm); some Points in Development of *Scorpio fulvipes*, 140; Development of Lung Books of Scorpio, 311; some Eurypterid Remains from Upper Silurian Deposit of Pentland Hills, 239
- Law of Limiting Apertures, Dr. E. J. Spitta, 186
- Lawrence-Hamilton (J.), Self-Registering Weather-Cock, 559
- Lawson (Dr. T. G.), Ortho- and Pararortho-toluidine, 92
- Layng (A. E.), Euclid's Elements of Geometry, 149
- Le Chatelier (H.); Metallic Borates, 240; the Theory of Regeneration, 288; Optical Determination of High Temperatures, 360; the Temperature of the Sun, 547
- Le Dentu, on the Implanting of Large Pieces of Decalcified Bones to fill up Losses of Substance of Skeleton, 95
- Leahy (A. H.), Law of Distribution of Velocities in a System of Moving Molecules, 527
- Leather Industry at the Chicago Exhibition, 587
- Lecture Experiment on Sound, Reginald G. Durrant, 415
- Lees (C. H.), the Thermal Conductivities of Crystal and other Bad Conductors, 382
- Leeward Islands, Meteorological Report for 1890, 528
- Lefebvre (Julien), the Dielectric Power, 95
- Lefèvre (Julien), the Attraction between Two Disks separated by a Dielectric, 575
- Lehmann (Dr. Paul), the Elements of the Minor Planets, 42
- Lehmann (Herr) on the Camel, 87
- Leibius (Dr. A.) on Scientific and Technical Education in New South Wales, 88
- Leigh (Hon. M. Cordelia E.), an Account of British Flies (Diptera), 173
- Leigh (Randle), Outlines of Practical Physiological Chemistry, 292

- Leleir (M.), Prevention of Hiccough by Pressure on the Phrenic Nerve, 312
- Lemming, Migration of the, F. Howard Collins, 149; W. Duppa-Crotch, 199, 294; Prof. Geo. J. Romanes, F.R.S., 249; W. Mattieu-Williams, 294
- Lemurs and Insectivora, Placentation of certain, Hubrecht, 600
- Lepidodendrons, Fossil, on the Discovery of Two Specimens of, in the Neighbourhood of Bathurst, New South Wales, W. J. C. Ross, 424
- Lepidoptera : of Winchester, 115; Stridulation in certain Lepidoptera, G. F. Hampson, 503; the Gradual Extinction of many Species of Lepidoptera in the Fens, Dr. Wheeler, 567; Pigments of, F. Gowland Hopkins, 581; T. H. Perry Coste, 605; Prof. R. Meldola, F.R.S., 605
- Lesage (P.), Chloride of Sodium in Plants, 312
- Leslie (Robert C.), Eclipse of the Moon, 53
- Lester's (Dr. Brown) Collection of the Flora of the River Gambia, 278
- Leucocytes, Influence of, on the Clotting of Blood, Dr. Lilienfeld, 599
- Levasseur (Emile), Surfaces and Population of European States, 528; Population of the Five Continents, 552
- Leveau (G.), Tables of Vesta, 95
- Levels, J. A. C. Oudemans, 240
- Levett (R.), the Elements of Plane Trigonometry, 509
- Lévy (Albert), Ammonia in Atmospheric Waters, 168
- Levy (Dr. Max), Influence of Blood Supply to Skin on Sweet Secretion as seen in Paw of Cat, 312
- Lévy (M.), Titanium Phenylate and other Compounds in which Hydroxylic Hydrogen of Phenols is replaced by Titanium, 589
- Lewes (V. B.), the Luminosity of Coal Gas Flames, 382; the Origin of Acetylene in Flames, 525; Air and Water, 531
- Ley (Annie), Sun Pillar, 484
- Libraries, Free Public, in Manchester, 157
- Lick Spectroscope, the, 473
- Liège School of Mines and Engineering, 116
- Ligation of the Great Arteries in Continuity, a Treatise on the, with Observations on the Nature, Progress, and Treatment of Aneurism, Charles A. Ballance and Walter Edmunds, Dr. M. Armand Ruffer, 530
- Light, Sir H. Trueman Wood, 269
- Light, Zodiacal, O. T. Sherman, 381
- Light, Electrodynamic Theories and the Electro-magnetic Theory of, M. Poincaré, Prof. A. Gray, 367
- Light on Silver Chloride, Thermodynamical View of Action of, H. M. Elder, 524
- Light, Crystalline Absorption and the Choice between the Different Theories of, E. Carvallo, 528
- Light, Magnesium as a Source of, Fred. J. Rogers, 622
- Lighthouses, Burning Oils for, E. P. Edwards, 379
- Liquids, the Flow of, in Capillary Tubes, Albert Colson, 120
- Lilienfeld (Dr.), Influence of Leucocytes on the Clotting of Blood, 599
- Limpach (L.), New Method of Preparing  $\beta$ -Dinaphthylene Oxide, 93; Ethyldimethylamidobenzene, 551
- Limpet's Power of Adhesion, the, Percy A. Aubin, 464
- Limpet's Strength, the, J. Lawrence Hamilton, 487
- Linder (S. E.), Metallic Hydrosulphides, 262; Solution and Pseudo-solution, *il.*, 263
- Lindsay (R.), Insectivorous Plants, 157
- Lindsay's (Mr.) Expedition in Western Australia, D. Murray, 425
- Line of Sight, Motion of Stars in the, Prof. H. C. Vogel, 280
- Line Spectra of the Elements, on the, Prof. C. Runge, 607
- Linebarger (C. E.), on the Nature of Colloid Solutions, 622
- Linnean Society, 93, 120, 166, 215, 335, 383, 454, 479, 526
- Lippmann's Colour Photography, 119
- Liquids, the Mechanical Stretching of, A. M. Worthington, 358
- Liverpool, Telephone Installation at Adelphi Hotel, 184
- Littledale (Mr. and Mrs.) Journey across the Pamirs, 90
- Littledale (Harold), Big Game in India, 158
- Liversidge (A., F.R.S.), on the Rusting of Iron, 424
- Living World, the, Whence it Came and Whither it is Drifting, Prof. H. W. Conn, 317
- Lizard, Enormous American, L. Stejneger, 40
- Locard (A.), Les Coquilles Marines des Côtes de France, 219
- Locky (Rev. J. B.), the First Book of Euclid's Elements, 460
- Lockyer (Prof. J. Norman, F.R.S.), Motion of Stars in the Line of Sight, 117; on some Points in Ancient Egyptian Astronomy, 296, 373; the New Star in Auriga, 429, 473; the Origin of the Year, 487
- Locust of New South Wales, the Plague, A. S. Olliff, 520
- Lodge (Prof. Oliver J., F.R.S.), Vacuum Tubes and Electric Oscillations, 366; Aberration Problems, 549
- Lothe (Dr.), Observations of Mars, 326
- London County Council, the New, and Technical Education, 566
- London Hospital, Mr. F. J. M. Page appointed to Chair of Chemistry and Physics at, 566
- London, Royal Commission to Investigate the Question of a Teaching University for, 612
- London Town, Within an Hour of, 557
- London, University of, W. T. Thisselton-Dyer, F.R.S., 392; Prof. E. Ray Lankester, F.R.S., 413; Prof. W. F. R. Weldon, F.R.S., 440
- London, the Water-supply of, John Hopkinson, 88; Appointment of Commission on, 470
- Loney's Elementary Dynamics, 20
- Longridge (James Atkinson), the Artillery of the Future and the New Powders, 146
- Lopatin (M.), Rocks Collected by, on the Podkamennaya Tunguska, 597
- Loschard (Herr), Rotation of Venus, 210
- Love (J.), Aurora Borealis, 223
- Löven (Prof. Svén), Resignation of his Position as Senior Keeper in the Stockholm Natural History Museum, 613
- Lucas (F. A.), Animals recently Extinct or Threatened with Extinction, 305
- Lumholtz (the Carl), Explorations in Northern Mexico, 136
- Luminous Clouds, Proposals for a Co-operative Observation of the so-called, 117
- Lunar Eclipse, Total, of November 15, 42
- Lunar Eclipses, Increase of the Earth's Shadow during, Dr. Hartmann, 498
- Lunge (George, Ph.D.), the Manufacture of Sulphuric Acid, Prof. T. E. Thorpe, F.R.S., 121
- Lunge (George, Ph.D.), and F. Hurter, Ph.D., the Alkali Maker's Hand-book, Prof. T. E. Thorpe, F.R.S., 121
- Lydekker (Richard), Catalogue of Fossil Birds in the British Museum, 33; *Dactytherium ovinum*, 94
- Lynn, Large Greenland Shark stranded at, T. Southwell, 546
- Lyons (A. B.) the Salt Lake of Aaia Paakia, 29
- Lyons (C. L.), Features of Hawaiian Climate, 190
- Macadamising Roads, Warning against the use of Rotten Flints for, C. Carus-Wilson, 379
- McAuley (A.), Quaternions as a Practical Instrument of Physical Research, 423
- MacBride (E. W.), the Development of the Oviduct in the Frog, 450
- McClellan (F.), Spectra of the Sun and Metals, 159
- McClelland (W.), a Treatise on the Geometry of the Circle, and some Extensions to Conic Sections by the Method of Reciprocation, 412
- Macdonald (H. M.), the Self-Induction of Two Parallel Conductors, 166
- Macgowan (Dr.), the Origin of the Ass, the Cat, and the Sheep in China, 285
- MacGregor (Prof. J. G.), Auroras at Halifax, 7
- Mackenzie (J. E.), Synthesis of Hexahydroterephthalic Acid, 383
- McKinley Tariff and Scientific Instruments, 208
- McLachlan (R., F.R.S.), Sparrows and Crocuses, 441
- McLachlan (R., F.R.S.), Abbreviated Wings of the Male Caddis-fly, 623
- Macley (Sir Wm.), Death and Obituary Notice of, 303
- Macpherson (A. Holte), Torpid Cuckoo, 416
- Macro-Lepidoptera and Birds of Winchester, 115
- Madras Observatory, Proposed Removal of, 258
- Magnesium as a Source of Light, Fred. J. Rogers, 622
- Magnetism : Electricity and Magnetism, by Amédée Guillemin, Prof. A. Gray, 1; some Experiments made with the View of ascertaining the Rate of Propagation of Induced Magnetism in Iron, Fred. T. Trouton, 42; Electro-magnetism, S. P. Thompson, F.R.S., Prof. A. Gray, 73; Magnetic Rotary Power of Solutions of Ammonium and Sodium Salts of Fatty Acids, Dr. W. H. Perkin, F.R.S., 92; Attraction of Liquid Oxygen by Faraday Magnet, Prof. Dewar, 154; a Permanent Magnetic Field, W. Hibbert, 191; Magnetic Disturbance, G. M. Whipple, 304; Magnetic Perturbation of February 13-14, 1892, M. Moureaux, 408; Magnetic Storm of February 13-14, 1892, 493; H. Wild, 480; Magnetic Storms, Dr. M. A. Veeder, 557; a First Book of Electricity and Magnetism, W. Perren Maycock, 248; Influence of

- Electric Discharge during Thunderstorms on Apparatus registering Terrestrial Magnetism, Em. Marchand, 264; Absolute Values of Magnetic Elements on January 1, 1892, M. Moureaux, 264; Magnetization of Iron, Prof. C. G. Knott, 431
- Maiden (J. A.), Panax Gum, 567
- Maize as Food, the Value of, 234
- Maize, Wild, found in Mexico, 39
- Makino (Tomitarō), Illustrations of the Flora of Japan to serve as an Atlas to the Nippon-Shokubutsushi, 149
- Malacology, French, A. Locard, 219
- Malay Peninsula, the Iphoh Poison of the, Leonard Wray, Junior, 278
- Mallard (M.), the Native Iron of Cañon Diablo, Arizona, 575
- Mallet (F. R.), Physiological Action of Diminished Atmospheric Pressure, 606
- Mammalia, Catalogue of, in the Indian Museum, Calcutta, W. L. Sclater, 50
- Man, Beast and, in India, John Lockwood Kipling, 131
- Man, Evolution of, Prof. Ernst Haeckel, 482
- Man in Nature, Paul Topinard, 457
- Man's Place in Nature, Prof. N. S. Shaler, 220
- Manchester, Free Public Libraries in, 157
- Manchester Field Naturalists' Society, Programme of Summer Excursions, 614
- Manchu Race, the, 523
- Mangrove Vegetation in the Malay Archipelago, W. B. Hemsley, 3
- Mangrove as a Source of Tannin, the, Dr. J. T. Rothrock, 546
- Manipulation of the Microscope, Edward Bausch, 342
- Manitoba, the Prairie Larks of, E. E. Thompson, 135
- Mannerling (Geo. Edward), With Axe and Rope in the New Zealand Alps, Prof. T. G. Bonney, F.R.S., 147
- Maquenne (M.), Direct Combination of Nitrogen with Alkaline-Earthly Metals, 264; Barium and Strontium Nitrides, 360; Interesting Compound of Carbon and Barium, 404
- Marcano (V.), the Ammonia in the Air and Rain of a Tropical Region, 143
- Marchand (Em.), Influence of Electric Discharge during Thunderstorms on Apparatus registering Terrestrial Magnetism, 264
- Marchand (M.), Solar Observations, 352
- Marey (M.), Use of Chronophotography for Study of Aerial Locomotive Machines, 71
- Marine Biological Association, 116
- Mariotti (W.), Investigation into the Thunderstorms of 1888-89, 215
- Mars, Observations of, Dr. Lohse, 326
- Marshall (Arthur), Aurora, 605
- Marsupialia, Teeth-Development in the, M. F. Woodward, 335
- Maryland, a Geological Excursion in, Prof. G. H. Williams, 235
- Mascart (M.), Theory of Astronomical Aberration, 68; the Mass of the Atmosphere, 311
- Maskelyne (Prof. N. Story, F.R.S.), the Koh-i-Nur, 5, 126
- Mason (Prof. O. T.), Eskimo Throwing-sticks, 66
- Mason Science College, Birmingham, Report on Educational Work of, 519
- Massee (G.), British Fungi, Phycomyces and Ustilagineae, 411
- Massee (G.), Thermal Data concerning active Malic Acid and Potassium and Sodium Malates, 167; Tartaric Acid and the Tartrates of Sodium and Potassium, 432; the Heats of Formation of Potassium Carballylates, 456; Citric Acid, 504
- Mathematics: Prof. Kikuchi's Treatise on Geometry, 20; Loney's Elementary Dynamics, 20; "W = Mg," Prof. Arthur G. Webster, 29; an Introduction to the Differential and Integral Calculus, T. Hugh Miller, 52; Lemoine's Two Problems of Stamps, Prof. Schoute, 72; Mechanics for Beginners, Part I., Rev. J. B. Lock, 101; Mathematical Society, 119, 214, 335, 407, 502, 623; Bulletin of the New York Mathematical Society, 124, 341; Mathematical Exercises, A. T. Richardson, 125; the Loci of Singular Points and Lines occurring in Connection with Theory of Locus of Ultimate Intersections of a System of Surfaces, Prof. M. J. M. Hill, 141; Prof. D. T. Korteweg on Van der Waals's Isothermal Equation, 152; Equations of Propagation of Disturbances in Gyrostatically Loaded Media, J. Larmor, 214; Theory of Elastic Wires, A. B. Basset, F.R.S., 215; Harmonic Functions for the Elliptic Cone, E. W. Hobson, 335; Theorems relating to a Series of Coaxial Circles, R. Lachlan, 335; Stamp-folding Problem, Prof. Schoute, 335; the Logical Foundations of Applied Mathematical Sciences, Mr. Dixon, 407; Mathematical Analogies between various Branches of Physics, Prof. Bragg, 423; the Theory of Determinants in the Historical Order of its Development, Thos. Muir, 481; the Simplest Equivalent of a given Optical Path, Dr. J. Larmor, 502; Dualistic Differential Transformations, E. B. Elliott, F.R.S., 503; Rectification of the Cartesian Oval, Prof. Greenhill, F.R.S., 503; Elementary Mathematical Astronomy, C. W. C. Barlow and G. H. Bryan, 579; Klein's Modular Functions, F. N. Cole, 597
- Mathews (F. E.),  $\alpha$  and  $\beta$  Modifications of Chlorobenzene Hexachloride, 263
- Matignon (M.), Heat of Formation of Hydrazine and Hydrazoic Acid, 95
- Mattieu-Williams (W.), Migration of the Lemming, 294
- Maudslay (Alfred P.), Ancient Civilization of Central America, 617
- Maudner (E. W.), Spectrum of Nova Aurige, 616
- Maxwell (J. Clerk), Theory of Heat, 222
- Maxwell, M. Poincaré and, Prof. Geo. Francis Fitzgerald, F.R.S., 532
- Mayall (John), Proposed Fund for the Family of the late, 86
- Maycock (W. Perren), a First Book of Electricity and Magnetism, 248
- Mayhew's Illustrated Horse Doctor, 27
- Measure and Weight, Examination of the Standards of, measured in the Houses of Parliament, 534
- Mechanical Engineers, Institution of, 22, 585; Annual Meeting, 355, 585
- Mechanics, Celestial, Two New Laws of, H. Struve, 70
- Mechanics for Beginners, Part I., Rev. J. B. Lock, 101
- Mechanics, American Superiority in, Coleman Sellers, 157
- Mechanics, Applied, Sheets and Tie-rods Laterally Loaded, Prof. J. Perry, F.R.S., 192
- Mechanics: the Law of Elastic Lengthening, J. O. Thompson, 311; the Flexure of Long Pillars under their own Weight, Prof. M. Fitzgerald, 479
- Medical Students, Physiological Chemistry for, F. Charles Larkin Randle Leigh, 292
- Mediterranean, Austrian Government Deep-Sea Exploration in, 518
- Medium for Preserving the Colours of Fish and other Animals, 212
- Medoc District, the Wines of the, 279
- Milk Ferment identical with Kefyr in use in Canada and United States, C. L. Mix, 471
- Meldola (Prof. R., F.R.S.), Photography as a Branch of Technology, 331; Pigments of Lepidoptera, 605
- Mendeleëff (D.), the Principles of Chemistry, 529
- Mendenhall (T. C.), the Use of a Free Pendulum as a Time Standard, 450
- Mental Arithmetic, Clive Cutbush, 78; Dr. K. Haas, 198
- Mercury Mining in Russia, 305
- "Meretrix," Lamarck, 1799, versus "Cytherea," Lamarck, 1806, C. R. Osten Sacken, 30
- Mergui, Tin Mining in, 496
- Merope, Measures of the Nebulæ near, 352
- Merrill (Geo. P.), Stones for Building and Decoration, 222
- Merz (Dr.), Lithium Nitride, 307; Magnesium Nitride, 280
- Meslans (M.), Synthesization of Two New Liquids containing Fluorine, 547
- Metallurgy: Iron Production in United States, Berkley, 65; Production of Pig-Iron in United States, John Birkinbine, 208; Value of Metallurgical Science, Prof. Roberts-Austen, 257; Prince Louis Lucien Bonaparte's Collection of Metals, 348; Art Metal Work; Bronze in the London Atmosphere, Prof. Roberts-Austen, 443; Metals at High Temperatures, Prof. W. C. Roberts-Austen, F.R.S., 534
- Meteoritic Iron, E. Cohen, E. Weinschenk, 69
- Meteoritic Iron, a New Locality for, with a Preliminary Notice of the Discovery of Diamonds in the Iron, Prof. A. E. Foote, 178
- Meteorology: U.S. Pilot Chart for October, 1891, 38; the Hydrology of Mitta Mitta, James Stirling, 40; the Climate of Alta Verapaz (Guatemala), Dr. Sapper, 41; Phenomenal Barometrical Depression (November 11, 1891), G. J. Symons, 65; Catalogue of Deutsche Seewarte Library, 65; the Magdeburger Zeitung for 1890, 65; Cloud-Observation at Sea, Prof. C. Abbe, 70; the Weather Bureau of the United States, 86; Meteorology of Finland, 87; International Conference of

- Meteorologists at Munich, 87; Electric Self-recording Rain-gauge, W. J. E. Binnie, 95; Wet and Dry Bulb Formulae, Prof. J. D. Everett, F.R.S., 95; Results of Observations at Akasso, F. Russell, 95; Atlas of the Meteorology and Physical Data of the Indian Ocean, 101; the Publications of the Meteorological Department of India, 113; Rainfall and Thunderstorms of Berlin, 114; Cyclones in Europe, 114; the Temperature of the Rivers of Central Europe, 114; Proposals for a Co-operative Observation of the So-called Luminous Clouds, 117; Cyclones in the Arabian Sea, 276; Cyclone Memoirs of the Arabian Sea, W. L. Dallas, 135; the Tides of the Bay of St. Malo, M. Heurtault, 143; the Ammonia in the Air and Rain of a Tropical Region, Marcano and Muntz, 143; Wind Direction, 149; Radiation of Upper Clouds round Barometric Minima, Dr. H. E. Hamberg, 156; Meteorological Observations at Cairo, 1868-88, Dr. J. Hann, 156; Meteorological Observations during Balloon Voyages, Dr. Assmann, 168; the Severe Gale of November 11, Chas. Harding, 181; Mr. E. Engelenburg, the new Director of the Dutch Observations on Land, 183; Annual Meteorological Report for Japan (1889), 184; Prof. Hazen's High Balloon Voyages, 189; Meteorology at French Association at Marseilles, A. L. Roich, 189; Features of Hawaiian Climate, C. L. Lyons, 190; Instructions Météorologiques, A. Angot, 196; Annals of Meteorological Office of Paris (1889), 208; a Weather Lexicon, Herr Seemann, 208; Investigation into Thunderstorms of 1888-89, W. Marriott, 215; the Prevalence of Fog in London, 1871-90, F. J. Brodie, 215; Report on the Meteorology of India in 1889, John Eliot, 217; Report on the Administration of the Meteorological Department of the Government of India, 217; Plan for Observations to determine Local Distribution and Altitude of Aurora, 234; Temperature Observations made in 1890 on Eiffel Tower, Angot, 234; Meteorological Observations at San José (1889), H. Pittier, 234; Pilot Chart of North Atlantic Ocean for December 1891, 258; Meteorological Report for Leeward Islands for 1890, 258; Frequency and Geographical Distribution of heavy Daily Rainfalls in European Russia, E. Berg, 258; Proposed Removal of Madras Observatory, 258; Proposed Construction of numerous fresh Meteorological Observatories in Japan, 258; Cause of Floating of Particles of Cloud and Fog, Herr von Frank, 259; Sun-spots and Air Temperature, 271; Harmonic Analysis of Hourly Observations of Air-temperature and Pressure at British Observatories, 279; the Year's Sunshine in the British Isles, 1881-90, 279; the Quantity of Sugar produced in various Plants as a Means of determining the Meteorological Elements concerned, Abbé Buvé, 279; new Condensation Hygrometer, Henri Gilbault, 283; on the Number of Dust Particles in the Atmosphere of various Places in Great Britain and on the Continent, with Remarks on the Relation between the Amount of Dust and Meteorological Phenomena, John Aitken, F.R.S., 299; Curves showing Fluctuations of Temperature and Pressure at Base and Summit of Mount Washington, 304; Temperature Observations at Geneva, M. Chaix, 304; Prof. Wiborg's Air-pyrometers, John Crum, 304; Thermometer-Temperature and Skin-Temperature, M. Vincent, 304; Curious Nocturnal Rosy Sky Light at Berlin, 324; Rainfall Atlas of Jamaica, Maxwell Hall, 324; Evaporation and Condensation, Baldwin Latham, 335; Observations on the Flow of Underground Water, Baldwin Latham, 335; Ammonia in Rainwater, A. Muntz, 336; Presidential Address of M. Janssen to French Meteorological Society, 350; Barometric Gradients, H. Lasne, 350; International Monthly Charts of Mean Barometric Pressures and Wind Directions, General Greeley, 350; Ferrel's View of the General Circulation of the Atmosphere, Prof. W. M. Davis, 357; Cold Waves, Dr. A. Woeikof, 357; Nacreous Clouds, T. W. Backhouse, 365; Remarkable Display of Aurora Borealis in America, 378; Causes of the Famine in Russia, Dr. A. Woeikof, 378; Silver Thaw at Ben Nevis Observatory, R. C. Mossman, 378; the Mountain Meteorological Stations of the United States, A. L. Rotch, 403; the Blue Hill Meteorological Observatory, 418; Untenableity of Atmospheric Hypothesis of Epidemics, Hon. R. Russell, 431; the Origin of Influenza Epidemics, H. Harries, 431; the Phenological Observations for 1891, E. Mawley, 431; Relationship of Atmospheric Electrical Phenomena to Terrestrial Magnetism, Dr. Arendt, 432; Observations made in a Captive Balloon, Dr. Assmann, 432; the Service of Roumania, 444; the Danish Meteorological Institute and Deutsche Seewarte Daily Synoptic Weather Charts for North Atlantic Ocean, 444; Influence of Total Solar Eclipse on Air Pressure, Herr Steen, 444; the Samoan Hurricane, Everett Hayden, 461; the Magnetic Storm of February 13-14, 1892, 493; H. Wild, 480; the Winter Storms of Northern India, Henry F. Blanford, F.R.S., 490; Atlantic Weather and its Connection with British Weather, R. H. Scott, 496; Report of the Meteorological Council, 518; Cloud Pictures, Dr. Singer, 518; Prof. G. Hellmann's Rainfall Record Experiments, 545; Value of Meteorological Instruments in Selection of Health Resorts, Dr. C. Theodore Williams, 551; Magnetic Storms, Dr. M. A. Veeder, 557; Meteorological Council's Issue of Tables of Monthly Means for Pressure, Temperature, and Rainfall, 567; Research on Extremes of Temperature in Europe, Dr. Lachmann, 576; Dust-Counting on Ben Nevis, Angus Rankin, 582; Deutsches Meteorologisches Jahrbuch, 1890, 587; the General Circulation of the Atmosphere, Dr. J. M. Fernter, 593; the Meteorological Station of Naha, Luluku Islands, Japan, 597; Aurora, George M. Seabrook, 605; Arthur Marshall, 605; Arthur E. Brown 605; the Changefulness of Temperature as an Element of Climate, 610; Royal Meteorological Society, 623; Anemometer Comparisons, W. H. Dines, 623; Meteorological Society (see Royal)
- Meteors: Fall of Meteorites in Madras, 20; the Tonganoxie Meteorite, by E. H. S. Bailey, 119; a Brilliant Meteor, Thomas Heath, 295; Large Meteor of January 24, 1892, W. F. Denning, 317
- Metschnikoff (Dr. Elie): Leçons sur la Pathologie Comparée de l'Inflammation faites à l'Institut Pasteur en Avril et Mai, 1891, Prof. E. Ray Lankester, F.R.S., 505
- Mexican Atlas, 66, 102
- Mexican Leatherwork, Surviving Specimens of Ancient, 66
- Mexican Shields, Ancient, Zelia Nuttall, 520
- Mexico, Northern, Carl Lumholtz's Explorations in, 136
- Mexico, Projected Abandonment of Villages near Colima in Consequence of Activity of Neighbouring Volcano, 158
- Mexico, Wild Maize found in, 39
- Meyer (Lothar), Outlines of Theoretical Chemistry, Prof. M. M. Pattison Muir, 601
- Meyer (Prof. Victor): Royal Society Medallist, 111; Silent Combination of Hydrogen and Oxygen, 616
- Mica, Use of, at the Chicago Exhibition, 615
- Michael (A. D.), Association between Gamsidis and Ants, 164
- Michelson (A. A.), Measurement of Jupiter's Satellites by Interference, 160
- Michigan Mining School, 88
- Micrometric Measurements, on the Influence of Ring and Disk Blinds in, Dr. Walter Wislicenus, 137
- Microscopy: Sir W. J. Sellard's Apparatus for making Accurate Measurements with Camera Lucida, 46; the Leach Lantern Microscope, W. I. Chadwick, 47; Microscopic Structure of Hard Steel, Behrens, 48; Photography Applied to the Microscope, F. W. Mills, 77; the Kenal Organs of Certain Decapod Crustacea, W. F. R. Weldon, 140; Nephridium of Lumbricus and its Blood-supply, Dr. W. B. Benham, 140; *Pelomyxa viridis*, Dr. A. G. Bourne, 140; the Medusae of *Millepora Murrayi* and the Gonophores of *Allopora* and *Distichopora*, Dr. S. J. Hickson, 140; the Formation and Fate of the Primitive Streak in the Frog, Dr. A. Robinson and R. Assheton, 140; Some Points in Development of *Scorpio fulvipes*, M. Laurie, 140; the Occurrence of Pseudopodia in Diatomaceous Genera *Melosira* and *Cyclotella*, J. G. Grenfell, 140; the Resolution of *Amphipleura pellicida*, J. W. Gifford, 143; a New Form of Mechanical Stage, H. Bernard, 239; Resolution of Podura, Hon. J. G. P. Vereker, 239; the late Dr. Carpenter's Microscope and its Relations, Seventh Edition of, by Rev. W. H. Dallinger, F.R.S., Prof. E. Ray Lankester, F.R.S., 313; Manipulation of the Microscope, Edward Bausch, 342; Wandering Cells in Echinoderms, &c., H. E. Durham, 450; the Excretory Processes in Marine Polyzoa, S. F. Harmer, 450; the Differentiation of Leprosy and Tubercle Bacilli, Chas. Slater, 450; *Onchomesoma Steenstrupii*, A. E. Shipley, 450; Note on a Sieve-like Membrane across Oesula of a Species of Leucosolenia, E. A. Minchin, 450; the Development of the Oviduct in the Frog, E. W. MacBride, 450; the Nauplius Eye persisting in some Decapods, Margaret Robinson, 450; a New Genus of Synascidians from Japan, Okada and Willey, 450; Microscopic Structure of Oolitic Iron from Lorraine, M. Bleicher, 504; the Calculable Limit of Microscopic Vision, Prof. Czapski, 575; on the Microscopic

- Structure and Residues Insoluble in Hydrochloric Acid in the Devonian Limestone of South Devon, Edward Wethered, 597
- Migration of the Lemming, F. Howard Collins, 149; W. Dappa-Crotch, 199, 294; Prof. Geo. J. Romanes, F.R.S., 249; W. Mattieu-Williams, 294
- Milk, R. Henry Rew on the Statistics of the Production and Consumption of, in Great Britain, 614
- Milk and Diphtheria, Dr. R. Thorne Thorne, 123
- Milky Way, the Grouping of Stars in the Southern Part of the, H. C. Russell, F.R.S., 423
- Milky Way, New Star in the, Ralph Copeland, 325
- Mill (Dr. Hugh Robert): The Realm of Nature, 390; appointed Librarian to Royal Geographical Society, 566
- Miller (Dr. A. K.), Frangulin, ii, 214
- Miller (T. Hugh), an Introduction to the Differential and Integral Calculus, 52
- Mills (F. W.), Photography applied to the Microscope, 77
- Milne (Prof. John, F.R.S.), Seismometry and Engineering in Relation to the Recent Earthquake in Japan, 127
- Mimicry, Topical Selection and, David Syme, 30; Dr. Alfred R. Wallace, 30
- Minchin (E. A.), Note on a Sieve-like Membrane across Oscula of a Species of Leucosolenia, 450
- Mineralogy: Mineralogical Society, 19; Boleite, a New Mineral, 23; New Analysis of Uraninite, W. F. Hillebrand, 119; the Koh-i-Nur, Prof. N. Story-Maskelyne, F.R.S., 5, 126; Dr. Valentine Ball, F.R.S., 126; the Sillimanite Group and the Part played by Aluminium in the Silicates, W. Wernadsky, 141; Economic British Minerals at the Chicago Exhibition, 155; Discovery of Uranium in Swedish Anthracitic Minerals, Baron Nordenskiöld, 209; the Mineral Wealth of Brazil, 235; Microscopic Structure of Oolitic Iron from Lorraine, M. Bleicher, 504; Manganese Nodules in the Marine Deposits of the Clyde Sea-area, Murray and Irvine, 527; the Native Iron of Cañon Diablo, Arizona, M. Mallard, 575
- Mines, Copper, of French Congo, 135
- Mines and Mining, a Handy List of Books on, 116
- Mines, Royal School of, 257
- Mining, Electricity in Relation to, Ernest Scott, 184
- Mining, the Michigan School of, 88
- Mining in Russia, Mercury, 305
- Mining, Tin, in Mergui, 496
- Minor Planets, the Elements of the, Dr. Paul Lehmann, 42
- Missouri Botanical Garden, Pupils at the, 88
- Mistletoe to its Parent Tree, the Relation of the, Dr. G. Bonnier, 421
- Misunderstanding, a Possible, Thos. H. Blakesley, 441
- Mitchell (Hubbard Winslow), Evolution of Life, or Cause of Change in Animal Forms, 364
- Mitchell (J. C.), the Lateral Sense-organs of Elasmobranchs, 239
- Mivart (Dr. St. George, F.R.S.), Implications of Science, 60, 82, 222, 343
- Mix (C. L.), Milk-ferment identical with Kefyr in use in Canada and United States, 471
- Model, Wave Motion, F. Cheshire, 347
- Moissan (Henri): Two New Phospho-iodides of Boron, 67; Phosphides of Boron, 136; Action of Alkaline Metals on Boric Acid, 408; the Preparation of Amorphous Boron, 421; the Properties of Amorphous Boron, 527; Crystallization of Tetra-iodide of Carbon, 209; Colour and Spectrum of Free Gaseous Fluorine, 260
- Molecular Velocity, Relation of Voltaic Electromotive Force to, Dr. G. Gore, F.R.S., 596
- Molecular Weight of Gadolinia, 237
- Monck (W. H. S.), Proper Motions of the Stars, 8
- Monckton (H. W.), Gravel South of the Thames, Guildford to Newbury, 263
- Monkeys, Tender Feeling in, Robert Morley, 350
- Monteiro (Rosa), Delagoa Bay, its Natives and Natural History, 124
- Montelius (Prof.), the Chronology of the Neolithic Age in Scandinavia and the Bronze Age in the East and Southern Europe, 39
- Moon, a Double, Rose Mary Crawshaw, 224
- Moon, Eclipse of the, Robert C. Leslie, 53
- Moon, Photography of the Eclipsed, 117
- Moon, the Recent Eclipse of the, Mrs. R. M. Crawshaw, 134
- Moon, Secular Acceleration of the, and the Length of the Sidereal Day, 137
- Moore (C. B.), Opening a Burial Mound in Florida, 567
- Moreno (Señor), Discovery of Aboriginal Skulls in the Argentine, 278
- Morgan (C. Lloyd), Animal Sketches, 291
- Morgue, the, in Paris, 116
- Moritz (E. R.) and G. H. Morris, a Text-book of the Science of Brewing, 100
- Morley (Robert), Tender Feeling in Monkeys, 350
- Morris (D.), the *Icerya Purchasi* at St. Helens, 115
- Morris (D.), on the Phenomena concerned in the Production of Forked and Branched Palms, 598
- Morris (G. H.) and E. R. Moritz, a Text-book of the Science of Brewing, 100
- Morris (Prof.), on Universities in Australia, 426
- Morrison (Dr. Joseph), Solar Heat, 589
- Moseley (Henry Nottidge, F.R.S.): Death of, 64; Obituary Notice of, Prof. E. Ray Lankester, F.R.S., 80
- Mossman (R. C.), Silver Thaw at Ben Nevis Observatory, 378
- Moths, Silk-producing, Colonel Swinhoe, 38
- Moureaux (Th.), Absolute Values of Magnetic Elements on January 1, 1892, 264; Magnetic Perturbation of February 13-14, 1892, 408
- Mueller (Baron von), the Protection of Birds in Victoria, 280; Diagnoses of New Papuan Plants, 496
- Muir (Prof. M. M. Pattison), Outlines of Theoretical Chemistry, Lothar Meyer, 601
- Muir (Dr. Thomas): appointed Superintendent-General of Education for Cape Colony, 443; the Theory of Determinants in the Historical Order of its Development, 481
- Muirhead (Lieutenant B. A.), a Plague of Frogs, 30
- Müller (Dr.): on the Telluric Spectrum, 21; Photometric Observations, 90
- Müller (Dr. Fritz), Dismissal of, 156
- Müller (Dr. Hugo, F.R.S.), the Chemistry of Paints and Paintings, A. H. Church, F.R.S., 241
- Muller (P. T.), a Study of the Velocity of Decomposition of Diazo-Compounds by Water, 480
- Munro (J.), Heroes of the Telegraph, 5
- Muntz (A.), the Ammonia in the Air and Rain of a Tropical Region, 143; Ammonia in Rain-Water, 336
- Murchison (Sir Roderick), Centenary of, 398
- Murray (D.) on Mr. Lindsay's Expedition in Western Australia, 425
- Murray (Dr. John), Manganese Nodules in the Marine Deposits of the Clyde Sea-Area, 527; Deep-Sea Deposits, 409
- Murray (Dr. T. S.), Electrolysis of Potassium Acetate Solutions, 93
- Muscat, Projected Tidal Observatory at, 134
- Musical Instruments, the Bow as Origin of Stringed, Dr. E. B. Tylor, 184
- Museum of Natural History, Paris, Reorganization of, 183
- Museum, the Science, and the Tate Gallery, 385; 433
- Museum, Proposed County, for Bucks, 114
- Museums of the Future, G. B. Goode, 421
- Museums, Typological, General Pitt-Rivers, 184
- Mussel-poisoning in Tierra del Fuego, M. Segers, 134
- Mycology: British Edible Fungi, M. C. Cooke, 75
- Nachtigal (Gustav), Bust of, 566
- Nacreous Clouds, T. W. Backhouse, 365
- Naden (Constance), Further Reliques of, 389
- Nathorst (Dr. A. G.), Fresh Evidence Concerning the Distribution of Arctic Plants during the Glacial Epoch, 273
- National Electric Light Association, Fifteenth Convention of the, 470
- Natural History: Opportunity for a Naturalist, Dr. P. L. Sclater, F.R.S., 174, 269; Reorganization of Paris Museum of Natural History, 183; Natural History of Isolated Ponds, Clement Reid, 325; Obituary Notice of Henry Walter Bates, Naturalist of the Amazons, 398; the Horse, a Study in Natural History, William Henry Flower, F.R.S., 436; Natural History Society of Buda Pesth, 471; Preference of certain Birds for certain Trees, 471; the Naturalist in La Plata, W. H. Hudson, Dr. Alfred R. Wallace, 553; the Gradual Extinction of many Species of Lepidoptera in the Fens, 567
- Natural Science, 421, 521
- Natural Science to Art, on the Relation of, Prof. E. du Bois-Reymond, F.R.S., 200, 224; W. Ainslie Hollis, 319
- Natural Waters, the Salts in, 78; F. H. Perry Coste, 176; Robert B. Hayward, F.R.S., 176

- Nature, L'Électricité dans la, Georges Dary, 460  
 Nature, La Place de l'Homme dans la, T. H. Huxley, 197  
 Nature, Man in, Paul Topinard, 457  
 Nature, Man's Place in, Prof. N. S. Shaler, 220  
 Nature, the Realm of, Hugh Robert Mill, 390  
 Nature Teachings, Cyclopædia of, H. Macmillan, 248  
 Navajo Indians, Weaving as practised by the, Dr. Shufeldt, 260  
 Naval Architects, Institution of, 570  
 Nebulæ, some Apparently Variable, Lewis Swift, 261  
 Nebulæ near Merope, Measures of the, 352  
 Nebulæ and Star Clusters, Observations of, M. Bigourdan, 352  
 Nebulæ, Variability of, Dr. Lewis Swift, 522  
 Neesen (Prof.), Measurements of Latent Heats of Evaporation by means of a Condensation Calorimeter, 456  
 Negreano (D.), Variation, with Temperature, of Dielectric Constant of Liquids, 408  
 Neolithic Age in Scandinavia, Chronology of the, Prof. Montelius, 39  
 Nephrite Axe found at Ohlau, Silesia, the, Dr. O. Schoetensack, 379  
 Neptune, the Discovery of, Prof. Holden, 522  
 New Forest Bill, the, H. Goss, 295  
 New Forest in Danger, the, Herbert Goss, 343  
 New Fragments, John Tyndall, F.R.S., 508  
 New Guinea, British, J. P. Thomson on Recent Explorations and Discoveries in, 425  
 New Guinea, Geology of, R. L. Jack, 209  
 New South Wales: the Acclimatization of the Avocado Pear in, F. Turner, 66; Scientific and Technical Education in, 88; Tea Culture in, W. T. Robertson, 260  
 New York Mathematical Society, 124; Bulletin of the, 341  
 New York and Philadelphia, Proposed Ship Canal between, Prof. L. M. Haupt, 497  
 New York Scientific Alliance, the, 544  
 New York State, Earthquake in, 259  
 New Zealand Alps, with Axe and Rope in the, Geo. Ed. Manering, Prof. T. G. Bonney, F.R.S., 147  
 New Zealand, on a Recent Discovery of the Remains of Extinct Birds in, Prof. Henry O. Forbes, 416  
 New Zealand Region, Aphanapteryx in the, Prof. Henry O. Forbes, 580  
 Newcomb (Prof.), Periodic Perturbations of the Four Inner Planets, 548; N.P.D.'s observed with Greenwich and Washington Transit Circles, 548  
 Newton (Prof. Alfred, F.R.S.), Ornithology of the Sandwich Isles, 465, 532  
 Newton (Prof. H. A.), Capture of Comets by Planets, 186  
 Nicaragua, Earthquake in, 471  
 Nicholson (A. C.), High-level Glacial Grounds near Oswestry, 165  
 Nickel Heat Engine, W. B. Croft, 392; Rev. Frederick J. Smith, 464  
 Nile, Reported Discovery of Ultimate Source of, 154  
 Nitrogen, Results of Experiments at Rothamsted on the Question of the Fixation of Free, Dr. J. H. Gilbert, F.R.S., 32  
 Nitrogen, the Urinary Secretion of, Dr. Gumlisch, 599  
 Noble (Capt. A., F.R.S.), First Visible Colour of Incandescent Iron, 484  
 Nomenclature in Biology, Suggestions for securing Greater Uniformity of, Prof. T. Jeffery Parker, F.R.S., 68  
 Nomenclature, Botanical, Dr. Otto Kuntze, W. Botting Hemley, 169  
 Nomenclature, Scientific, H. St. A. Alder, 104  
 Non-Euclidian Geometry, Prof. H. Poincaré, 404  
 Non-Metallic Chemistry, Synopsis of, W. Briggs, 604  
 Nordenskiöld (Baron), Discovery of Uranium in Swedish Anorthitic Minerals, 209  
 Norfolk and Norwich Naturalists' Society, 567  
 North (Marianne), Recollections of a Happy Life, 602  
 North America, Nature and Man in, Prof. N. S. Shaler, 220  
 North Atlantic Weather Charts, Synoptic, 444  
 Nova Aurige, Observations of the Spectrum of, Dr. Henry Crew, 509  
 Nova Aurige, Spectrum of, E. W. Maunder, 616  
 Nova Cygni, Photographs of the Region of, 617  
 Novelists, Technical Education for, 487  
 Nuovo Giornale Botanico Italiano, 46, 478  
 Nurhagi of Sardinia, Dr. Ermling on the, 114  
 Nuttall (Zelia), Ancient Mexican Shields, 520  
 Oak, The, a Popular Introduction to Forest Botany, H. Marshall Ward, F.R.S., 509  
 Object Glasses, Diffraction Effects produced by placing Screens in Front of, Prof. Pritchard, 237  
 Objective Prism, the, Prof. Pickering, 521  
 Objectives, Telescopic, A. Fowler, 204  
 Observatories: Proposed Removal of Madras Observatory, 258; Report of the U.S. Naval Observatory, 352; the Warner Observatory, 422; Cordova Observatory, 446; Photography at the Cape Observatory, D. Gill, 600  
 Observatories, Meteorological: Projected Tidal Observatory at Muscat, 134; Blue Hill Meteorological Observatory, 418  
 Oddone (Dr. Emil), on Earth Vibrations, 510  
 Ogilby (J. D.), Dr. Stirling's new Australian Animal (*Notoryctes typhlops*), 135  
 Ohic, Excavations of the Prehistoric Mounds in, 20  
 Ohio: Discovery of Remarkable Prehistoric Tomb, 157; the Geology of, in connection with the Average Yield of Wheat, 420  
 Oka (Asajiro), a New Genus of Synsacids from Japan, 450  
 Olive Culture in Australia, Principal J. L. Thomson, 135  
 Olliff (A. S.), the Plague Locust of New South Wales, 520  
 Ontario, Grape Culture in, 209  
 Opium Question, the, G. H. M. Batten, 545  
 Opossum, Ring-tailed, Curious Death of a, J. E. Dixon, 88  
 Optics: Optical Proof of the Existence of Suspended Matter in Flames, on an, Sir G. G. Stokes, F.R.S., 133; Optical Determination of High Temperatures, H. Le Chatelier, 360; Optics of Photography and Photographic Lenses, J. Traill Taylor, 364; Optical Lantern as an Aid in Teaching, C. H. Bothamley, 437; the Simplest Equivalent of a Given Optical Path, Dr. J. Larmor, 503; an Aerial Graphoscope for showing Effects of Persistence of Vision, E. S. Bruce, 574; the Dispersion of the Ultra-red Rays, Dr. Rubens, 576  
 Orange, Double, Gerald B. Francis, 534, 607  
 Organic Chemistry, a Hand-book of Industrial, Samuel P. Sadler, 125  
 Orientation of Ancient Monuments, Rev. Fred. F. Grensted, 464  
 Orientation, a Preliminary Statement of an Investigation of the Dates of some of the Greek Temples as derived from their, F. C. Penrose, 395  
 Origin of the Year, J. Norman Lockyer, F.R.S., 487  
 Orkneys, Supernumerary Rainbows Observed in the, Robert H. Scott, F.R.S., 223; M. Spence, 223  
 Ornithology: Migratory Birds passing over Dublin, 20; the Prairie Larks and Cranes of Manitoba, E. E. Thompson, 135; Intelligence in Birds, A. Wilkins, 151; Bird Gallery in the British Museum, 154; Capture of a Spotted Eagle near Colchester, 158; Threatened Extinction of Kentish Plover, W. Verner, 236; Spotted Eagle, Pratt and Son, 259; Additional Observations on Development of Apteryx, T. J. Parker, F.R.S., 311; Utilization of Homing Pigeons, W. B. Tegetmeier, 320; Harrow Birds, G. E. H. Barrett-Hamilton, 342; Nest of Eggs of Bird of Paradise, A. J. Campbell, 379; Remarkable Case of Humming Birds Nesting and Hatching in a Drawing-room, 383; Torpid Cuckoo, A. Holte Macpherson, 416; a Swan's Secret, Mrs. Jessie Godwin-Austen, 416; on the Origin of the Struthious Birds of Australasia, Prof. Hutton, 425; Ornithology of the Sandwich Isles, Prof. Alfred Newton, F.R.S., 465, 532; Albert F. Calvert, 485, 558; J. E. Harting, 532; Preference of Certain Birds for Certain Trees, 471; White's Thrush (*Turdus varius*), H. Seebohm, 479; Tame Jackdaws, E. C. Green, 545; the Great Skua in Shetland, W. E. Clarke, 545; Depredations of the Great Bower Bird in Northern Queensland, 588  
 Orthochromatic Plates for Astronomical Photography, M. M. Fabre and Andoyer, 280  
 Orthography of Geographical Names, 186  
 Osmond (M.), and the Alloys Research Committee of the Institution of Mechanical Engineers, 22  
 Ostwald (Prof. W.), Theory of Solutions, 193, 293, 415, 606; the Magnetic Rotation of Dissolved Salts, 383; the Dissociation of Nitrogen Peroxide, 383; Recent Advances in Physical Chemistry, 590  
 O'Sullivan (C. C.), Gedda Gums, the Dextro-Rotatory Varieties, 93  
 O'Sullivan (J.), Specific Rotatory and Cupric Reducing Power of Invert Sugar and of Dextrose obtained from Cane Sugar by means of Invertase, 551  
 Oudemans (Dr. A. C.), the Great Sea Serpent, 614  
 Oudemans (J. A. C.), Levels, 240

- Ouse, the, A. J. Taylor, 102  
 Owens (Prof. W. G.), Report of Solar Halos and Parhelia, 518  
 Oxford: Election of Mr. E. R. Lankester to the Linacre Professorship, 183  
 Oxford, Pass Examination Papers, a Defect in the, 443  
 Oxford University, Junior Scientific Club, 455, 503  
 Oxford University Museum, Fourth Annual Report of the Delegates of the, 572  
 Oxide, Phosphorous, A. E. Tutton, 446  
 Oxidant and Hydrogen, Silent Combination of, Prof. Victor Meyer and Herr Askenasy on, 616  
 Oyster Culture in Queensland, Saville-Kent, 66  
 Oysters at the Antipodes, 43  
 Ozone by Electric Silent Discharge, Experiments on the Production of, Siemens and Halske, 39
- Pacific, Eastern, Dredging Operations in the, Prof. Alex. Agassiz, 281  
 Page (Mr. F. J. M.), Appointed to Chair of Chemistry and Physics at London Hospital, 566  
 Palatability, Comparative, E. B. Titchener, 53  
 Palaeolithics: a Curious Stone Hammer found in the Thames, G. F. Lawrence, 324  
 Palaeolithic and Neolithic Period, the Continuity of the, J. A. Brown, 503  
 Palaeontology: Catalogue of Fossil Birds in the British Museum, R. Lydekker, 33; Discovery of Mammalian Tooth near Hastings, 39; some Eurypterid Remains from Upper Silurian Deposits of Portland Hill, Malcolm Laurie, 239; the Silchester Remains, Herbert Jones, 259; Fresh Evidence Concerning the Distribution of Arctic Plants during the Glacial Epoch, Dr. A. G. Nathorst, 273; on a Recent Discovery of the Remains of Extinct Birds in New Zealand, Prof. Henry O. Forbes, 416; Discovery of Remains of Prehistoric Animals in Endsleigh Street, Dr. H. Hicks, F.R.S., 566; Aberrant Fossil Ungulates of South America, 608  
 Palms, on the Phenomena Concerned in the Production of Forked and Branched, D. Morris, 598  
 Pameley (Caleb), Colliery Manager's Hand-book, 77  
 Pamir, Le, et sa Faune lépidoptérologique, 115  
 Pamirs, a Journey across the, 90  
 Pamirs, Journeys in the, and Adjacent Countries, Capt. F. E. Younghusband, 353  
 Pantelleria: Earthquakes at, 120; the October Eruption, North-West of, G. W. Butler, Prof. John W. Judd, F.R.S., 154; on the Matter thrown up during the Submarine Eruption North-West of, October 1891, Gerard W. Butler, 251; Geo. H. Perry, 251; Abstract of Mr. A. Ricco's Account of the Submarine Eruption North-West of, October 1891, G. W. Butler, 584; Geology of, G. Jervis, 207  
 Paper-making Industry in the United States, the, J. F. Hobart, 279  
 Parasitic Fungi and Moulds, G. Masee, 411  
 Paris: Academy of Sciences, 23, 47, 71, 95, 120, 143, 167, 192, 215, 239, 264, 287, 311, 336, 360, 384, 408, 431, 456, 480, 504, 527, 552, 575, 599, 624; Astronomy at the, March 21, 522; April 11, MM. Périgaud and Boquet, 589; the Morgue in, 116; Paris Museum of Natural History, Prof. Chauveau's Laboratory, 86; Reorganization of, 183; 1889 Annals of Meteorological Office of Paris, 208; Les Fleurs à Paris, Culture et Commerce, Philippe L. de Vilmorin, 510  
 Parke (Thos. Heazle), My Personal Experiences in Equatorial Africa as Medical Officer of the Emin Pasha Relief Expedition, 265  
 Parker (J.), Elementary Thermodynamics, 314  
 Parker (Prof. T. Jeffery, F.R.S.): Suggestions for securing Greater Uniformity of Nomenclature in Biology, 68; Additional Observations on Development of Apteryx, 311  
 Parmentier (F.), Chlorosulphide and Bromosulphide of Lead, 384  
 Parry (John), the Spectrum of Iron and the Periodic Law, 253  
 Pasco (Captain), on Early Discoveries in Australia, 425  
 Pasquale (F.), a New Carpellary Theory, 478; a New Theory of the Morphology of the Carpel in Flowering Plants, 546  
 Passmore (F. W.), the Aconite Alkaloids, iii, 525  
 Pathology: a Text-book of Chemical Physiology and Pathology, W. D. Halliburton and Dr. E. H. Starling, 51; Prevention of Hiccough by Pressure on the Phrenic Nerve, M. Leloir, 312; Animals rendered immune to Anthrax, Dr. Th. Weyer, 312; a New Epidemic in Vienna, 349; the Differentiation of Leprosy and Tubercle Bacilli, Chas. Slater, 450; the Tubercular Vaccination of the Dog, Héricourt and Richet, 576  
 Paton (Dr. Noel), Action of the Auriculo-Ventricular Valves, 311  
 Paul (R. W.), some Electrical Instruments, 574  
 Peabody (Cecil H.), Thermodynamics of the Steam Engine and other Heat Engines, Prof. A. G. Greenhill, F.R.S., 172  
 Peach (B. N.), the Olenellus Zone of the North-West Highlands, 453  
 Pear in New South Wales, the Acclimatization of the Avocado, F. Turner, 66  
 Peary (Lieut.), Proposed Expedition for Relief of, 183  
 Peat-bog Eruptions, Herr Klinge, 472  
 Pechard (E.), the Estimation of Molybdenum, 336  
 Peculiar Eyes, Jas. Shaw, 104; G. K. Gude, 151; E. B. Titchener, 177  
 Peek (Cuthbert G.), Fuzziness of some Variable Stars, 497  
 Pekelharing (Prof.), Composition of Fibrin Ferment, 408; Coagulation of the Blood, 600  
 Penfield and Wells (Messrs.), Remarkable Series of Compounds of Halogen Salts of Caesium with Two or more Atoms of Chlorine, Bromine, or Iodine, 325  
 Penrose (F. C.), a Preliminary Statement of an Investigation of the Dates of some of the Greek Temples as derived from their Orientation, 395  
 Percival and Co., Simple Proof of Euclid II. 9 and 10, 250  
 Perfume Farming in Victoria, Experimental, 305  
 Périgaud (M.), Astronomy at the Paris Academy, April 11, 589  
 Periodic Law, the Spectrum of Iron and the, John Parry, 253  
 Periodic Perturbations of the Four Inner Planets, Prof. Newcomb, 548  
 Periodic Variations in Latitude, Chandler, 589  
 Perkin (A. G.), Action of Nitric Acid on Oxanilide and its Analogues, 551  
 Perkin (Dr. W. H., F.R.S.), Magnetic Rotary Powers of Solutions of Ammonium and Sodium Salts of Fatty Acids, 92  
 Perkin (W. H., Jun.), Synthesis of Hexahydroterephthalic Acid, 383; a New Acid from Camphoric Acid, 551  
 Perkins (R. C. L.), selected to Investigate the Zoology of the Sandwich Islands, 322  
 Pernter (Dr. J. M.), the General Circulation of the Atmosphere, 593  
 Perot (A.), on Hertz Oscillations, 336  
 Perry (Geo. H.), on the Matter thrown up during the Submarine Eruption North-West of Pantelleria, October 1891, 251  
 Perry (Prof. J., F.R.S.), Struts and Tie-Rods Laterally Loaded, 192; Choking Coils, 520  
 Perseids observed in Russia in 1890, Th. Bredichin, 597  
 Persia and Kurdistan, Journeys in, Mr. Bishop, 248  
 Personal Equations in Transit Observations, 617  
 Peru, Central, Mr. Alexander Ross's Journey to Head Waters of the Ecayali, 519  
 Petermann's Mitteilungen, 588  
 Petrie (W. M. Flinders), Prehistory of Egypt, 580  
 Pevtsoff (General), Tibet Expedition, 45  
 Pfaff's Allgemeine Geologie als Exacte Wissenschaft, J. Joly, 126  
 Pfeiffer (Herr), Measurements of Process of Dissolution of Glass in Water by Change in Conductivity of Latter, 209  
 Pharaohs, Egypt under the, H. Brugsch-Bey, 363  
 Pharmaceutical Society at Edinburgh, 88  
 Phasemeter, a, John Trowbridge, 622  
 Phenomenon, a Rare, Alex. Graham Bell, 79  
 Philadelphia and New York, Proposed Ship Canal between, Prof. L. M. Haupt, 497  
 Philosophical Notes on Botanical Subjects, E. Bonavia, 483  
 Phoronomy, Dr. W. H. Besant, F.R.S., 462; A. B. Basset, F.R.S., 486; M. Am Ende, 486  
 Phosphorous Oxide, A. E. Tutton, 446  
 Photography: Photographic Pastimes, a Hand-book for Amateurs, by Hermann Schnaus, 5; Praktisches Taschenbuch der Photographie, Dr. E. Vogel, 51; Geological Photographs, 64; Applied to the Microscope, F. W. Mills, 77; Colour Photography by Lippmann's Process, 119; Aluminium and its Application to Photography, G. L. Addenbrooke, 134; a Shutter for Use in Stellar Photography, J. Joly, 167; Chronophotography, or Photography as Applied to Moving Objects, 228; Use of Chronophotography for Study of Aerial Locomotive Machines, Marey, 71; Orthochromatic Plates for Astronomical Photography, MM. Fabre and Andoyer, 280;

- Solar Prominences, Prof. G. E. Hale, 326; Photography of Solar Prominences, M. Deslandres, 405, 522; Photography as a Branch of Technology, Prof. R. Meldola, F.R.S., 331; Optics of Photography and Photographic Lenses, J. Traill Taylor, 364; Photographic Magnitudes of Stars, 380; the Draper Catalogue of Stellar Spectra, A. Fowler, 426; the Iford Manual of Photography, C. H. Bothamley, 460; Photography Applied to the Detection of Crime, Dr. Paul Jeserich, 568; Photography at the Cape Observatory, D. Gill, 600; Spectrum of Nova Auriga, 616; Photographs of the Region of Nova Cygni, 617; Photographs of a Part of Cygnus, M. Faye, 624
- Photometric Observations, Dr. Müller, 90
- Photometry, Colour, Capt. Abney, F.R.S., 213
- Phycomycetes and Ustilagineae, British Fungi, G. Masee, 411
- Phyllium, the, Dr. Sharp, 623
- Physics : Some Experiments Made with the View of Ascertaining the Rate of Propagation of Induced Magnetism in Iron, Fred. T. Trouton, 42; on the Virial of a System of Hard Colliding Bodies, Lord Rayleigh, F.R.S., 80; Van der Waals's Generalization regarding Corresponding Temperatures, Pressures, and Volumes, Prof. Sydney Young, 93; Physical Society, 93, 142, 191, 238, 358, 478, 524, 574; Annual General Meeting, 452; Dynamic Action and Ponderosity of Matter, by "Waterdale," 100; Experimental, on an Optical Proof of the Existence of Suspended Matter in Flames, Sir G. G. Stokes, F.R.S., 133; the Various Forms given to the General Equation expressing Behaviour of Liquids and Gases under Different Conditions of Volume, Temperature, and Pressure, Dr. P. A. Guye, 142; a New Theory concerning the Constitution of Matter, Dr. C. W. Burton, 142; Refraction and Velocity of Sound in Porous Bodies, Herr Heselhus, 156; the Thermal Emissivity of Thin Wires in Air, Ayrton and Kilgour, 162; Effect of Flaws on the Strength of Materials, J. Larmor, 166; Physical Theory of Solutions, W. Ostwald, 193; Smithsonian Standards for Physical Apparatus, Prof. S. F. Langley, 197; on the Virial Equation for Gases and Vapours, Prof. F. G. Tait, 199; Experimental Measurement of Process of Dissolution of Glass in Water by Change in Conductivity of Latter, Herr Pfeiffer, 209; the Theory of Regelation, H. Le Chatelier, 288; the Cause of an Ice Age, Sir Robert Ball, F.R.S., Prof. G. H. Darwin, F.R.S., 289; the Law of Elastic Lengthening, J. O. Thompson, 311; Experiments on Cause of Emission of Light by Gases, Dr. Pringsheim, 312; Wave Motion Model, F. Cheshire, 347; Experimental, the Mechanical Stretching of Liquids, A. M. Worthington, 358; Optical Determination of High Temperatures, H. Le Chatelier, 260; Collection de Mémoires relatifs à la Physique, Prof. J. J. Thomson, F.R.S., 361; Superheated Steam, Lord Rayleigh, 375; J. Macfarlane Gray, 413, 486; Prof. James A. Cotterill, F.R.S., 414; G. H. Bailey, 414; John Gangee, 438; Quaternions as a Practical Instrument of Physical Research, A. McAuley, 423; Mathematical Analogies between various branches of Physics, Prof. Bragg, 423; Heat Engines and Saline Solutions, Lord Rayleigh, F.R.S., 438, 510; Experimental, Supplementary Colours, Prof. S. P. Thompson, F.R.S., 452; the Relation between Kinetic Energy and Temperature in Liquids, Prof. Tait, 455; Long Rotating Circular Cylinders, C. Chree, 455; Measurements of Latent Heats of Evaporation by means of a Condensation Calorimeter, Prof. Neesen, 456; a Lecture Experiment in Surface Tension, E. D. Fridlander, 463; the Terms "Centrifugal Force" and "Force of Inertia," Geo. S. Carr, 463; a Nickel Heat Engine, W. B. Croft, 392; Rev. Fred. J. Smith, 464; Aberration, Lord Rayleigh, Sec. R.S., 499; Changes in Dimensions of Elastic Solids due to given Systems of Forces, M. C. Chree, 527; Law of Distribution of Velocities in a System of Moving Molecules, A. H. Leahy, 527; on the Tensions of Saturated Vapours of Different Liquids at same Pressure, Edmond Colot, 528; a Standard Condenser, H. Abraham, 528; Crystalline Absorption and the Choice between the Different Theories of Light, E. Carvallo, 528; Aberration Problems, Prof. O. Lodge, F.R.S., 549; Radiations of Incandescent Bodies and Optical Measure of High Temperatures, J. Violle, 552; Recent Advances in Physical Chemistry, Prof. W. Ostwald, 590; Physiological Action of Diminished Atmospheric Pressure, F. R. Mallet, 606
- Physiography : Elementary Stage, J. Spencer, 27; the Realm of Nature, Hugh Robert Mill, 390
- Physiology : a Text-book of Chemical Physiology and Pathology, W. D. Halliburton and Dr. E. H. Starling, 51; Prof. Stokvis on Mutual Antagonism, 72; on the Implanting of Large Pieces of Decalcified Bones to fill up Losses of Substance of Skeleton, Le Dentu, 95; the Renal Organs of certain Decapod Crustacea, W. F. R. Weldon, 140; the Nephridium of Lumbricus and its Blood Supply, Dr. W. B. Benham, 140; the Formation and Fate of the Primitive Streak in the Frog, Robinson and Assheton, 140; some Points in the Development of *Scorpio fulvipes*, M. Laurie, 140; a New Mode of Respiration in the Myriapoda, F. G. Sinclair, 164; the Foot as a Prehensile Organ in Hindoos, F. Regnault, 192; Outlines of Practical Physiological Chemistry, F. Charles Larkin and Randle Leigh, 292; Development of Lung-books of Scorpio, Malcolm Laurie, 311; Action of the Auriculo-Ventricular Valves, Dr. Noel Paton, 311; Influence of Blood Supply to Skin in Sweat-secretion as seen in Paw of Cat, Dr. Max Levy, 312; Extra-ordinarily Rapid Evaporation on Glacier, Prof. Boerstein, 312; Teeth Development in the Marsupialia, M. F. Woodward, 335; an Introduction to Human Physiology, Augustus D. Waller and Dr. E. H. Starling, 340; the Mechanism of the Closure of the Larynx, Prof. T. P. A. Stuart, 357; Note on the Behaviour of Sugar in Blood, Dr. Vaughan Harley, 407; Composition of Fibrin Ferment, Prof. Pekelharig, 408; the Development of the Oviduct in the Frog, E. W. MacBride, 450; Contributions to the Physiology and Pathology of the Mammalian Heart, Roy and Adami, 451; Action of Lymph in producing Intravascular Clotting, Dr. Shore, 455; the Abductor and Adductor Fibres of the recurrent Laryngeal Nerve, J. S. R. Russell, 573; Dr. Verigo's Experiments respecting Influence of Oxygen on Elimination of Carbon Dioxide by the Lungs, Prof. Zuntz, 576; Physiological Action of Diminished Atmospheric Pressure, F. R. Mallet, 606; Physiology of Respiratory Centres, Dr. Alfred Bienfait, 624
- Pickering (Prof.), Distribution of Energy in Stellar Spectra, 159; Stars having Peculiar Spectra, 210; Astronomical Possibilities at Considerable Altitudes, 498; the Objective Prism, 521
- Pictet's (Prof.) Laboratory at Berlin, Prof. R. du Bois-Reymond, 31
- Picton (H.), Metallic Hydrosulphides, 262; Physical Constitution of some Sulphide Solutions, 263; of Solution and Pseudo-solution, *ibid.*, 263
- Pigment in Yellow Butterflies, F. Gowland Hopkins, 197
- Pigments of Lepidoptera, F. Gowland Hopkins, 581; F. H. Perry Coste, 605; Prof. R. Meldola, F.R.S., 605
- Pilchard or Sardine, Growth of the, Prof. J. T. Cunningham, 255
- Pilchards, Matthias Lunn, 511; J. T. Cunningham, 558
- Pillar, Sun, Annie Levy, 484
- Piltshchikoff (N.), Polarization of Atmosphere by Light of Moon, 456
- Pinches (Thos. G.), the Tower of Babel and the Confusion of Tongues, 210
- Pisciculture, the Salmon Industry in British Columbia, 279
- Pitt-Rivers (General), Typological Museums, 184
- Pittier (H.), Meteorological Observations at San José during 1889, 234
- Pittsburg Electric Club, the, 568
- Placentation of certain Lemurs and Insectivora, Hubrecht, 600
- Plane Trigonometry, the Elements of, R. Levett and C. Davison, 509
- Planets, Capture of Comets by, Prof. H. A. Newton, 186
- Planets, Minor, the Elements of the, Dr. Paul Lehmann, 42
- Planets, Periodic Perturbations of the Four Inner, Prof. Newcomb, 548
- Plants, the Diseases of, New Journal devoted to, 20
- Plants, Grafted, W. H. Beeby, 151
- Plarr (Dr. Gustav), Obituary Notice of, 419
- Pleyte (C. M.), Use of the Sumpitan and Bow in Indonesia, 235
- Plover, Kentish, Threatened Extinction of the, W. Verner, 236
- Podkamennaya Tunguska, Rocks collected by M. Lopatin on the, 597
- Poincaré (Prof. H.): Poincaré's Thermodynamics, 245, 414, 439, 485, 532; Electrodynamic Theories and the Electromagnetic Theory of Light, Prof. A. Gray, 307; Non-Euclidian Geometry, 404; Poincaré and Maxwell, Prof. Geo. Fras. Fitzgerald, F.R.S., 532
- Poison, Arrow, A. Coppen Jones, 343



- Poison, Arrow, of Sarro Savages, Laborde and Rondeau, 278  
 Poison of the Malay Peninsula, the Ipoh, Leonard Wray, Jun., 278  
 Polar, on the Observation of North Polar Stars in the Vertical of, Truman Saffard, 159  
 Polarization of Atmosphere by Light of Moon, N. Piltschikoff, 456  
 Political Economy and Taxation, David Ricardo, 4  
 Pollination, Evolution in Methods of, Miss Alice Carter, 596  
 Polynesians, Lieut. Vedel on the, 615  
 Polytechnic Institute, Regent Street, Appeal on behalf of the, 250  
 Polytechnics and Recreation, Miss E. Cons, 28  
 Ponds, Isolated, Natural History of, Clement Reid, 325  
 Population in Austria-Hungary, the Increase of, 158  
 Population of the Five Continents, E. Levasseur, 552  
 Population and Surface of European States, Emile Levasseur, 528  
 Porter (T. C.), Alum Solution, 29; First Visible Colour of Incandescent Iron, 558  
 Portland, Oregon, Earthquake at, 586  
 Post (Dr. A. H.), Strange Symbolical Marriage Custom in India, 135  
 Poulenc (C.), Action of Potassium Fluoride on Anhydrous Chlorides, 552  
 Poulton (Edward B., F.R.S.), a Difficulty in Weismannism, 52; Warning Colours, 174  
 Pratt and Son, Spotted Eagle, 259  
 Precessional Globe, a New, Dr. K. Haas, 250  
 Precious Stones and Gems, their History, Sources, and Characteristics, Edwin W. Streeter, 531  
 Preece (W. H., F.R.S.), the Specification of Insulated Conductors for Electric Lighting, &c., 155  
 Prehistoric Animals in Endsleigh Street, Discovery of Remains of, Dr. H. Hicks, F.R.S., 566  
 Prehistoric Antiquities, Russian; the Slavonians of the First Centuries of our Era, Prof. Samokvasoff, 577  
 Prehistoric Mounds in Ohio, Excavation of the, 20  
 Prehistoric Remains, Opening of a Burial Mound in Florida, C. B. Moore, 567  
 Prehistoric Tomb in Ohio, Discovery of Remarkable, 157  
 Prehistoric Weapons: the Nephrite Axe found at Ohlau, Silesia, Dr. O. Schoetersack, 379  
 Prehistory of Egypt, W. M. Flinders Petrie, 580  
 Prestwich (Joseph, F.R.S.), the Raised Beaches and Rubble-drifts of the South of England, 453  
 Pringsheim (Dr.), Experiments on Cause of Emission of Light by Gases, 312  
 Prior (Dr. R. C. A.), Ripe Seeds of the Monkey-Puzzle Tree (*Araucaria imbricata*) of Chili, grown in England, 421  
 Prism, the Objective, Prof. Pickering, 521  
 Pritchard (Prof.), the Diffraction Effects produced by placing Screens in Front of Object Glasses, 237  
 Professional Duties, Exchange of, Prof. E. Ray Lankester, F.R.S., Prof. T. P. Anderson Stuart, 557  
 Projectiles, Calculation of Trajectories of Elongated, Rev. F. Bashforth, 473  
 Propagation of Induced Magnetism in Iron, some Experiments made with the view of ascertaining the Rate of, Fred. T. Trouton, 42  
 Pseudopodes of Diatoms, Alleged, Alf. W. Bennett, 177  
 Psychology: a Short Account of the Human Mind, F. S. Granger, 76  
 Psychology, Experimental, 234  
 Psychology as a Science in the United States, the Study of, C. W. Scripture, 568  
 Ptomaines Extracted from Urine in some Infectious Maladies, A. B. Griffiths, 72  
 Pullinger (W.), Platinum Tetrachloride, 551  
 Puma, the, F. W. Tree, 445  
 Pupin (Dr. M. I.), on the Action of Vacuum Discharge Streamers upon each other, 622  
 Putnam's (Prof.) Anthropological Exhibit at Chicago Exhibition, 259  
 Quantitative Chemical Analysis, Frank Clowes and J. Bernard Coleman, 578  
 Quarterly Journal of Microscopical Science, 140, 450  
 Quaternions as a Practical Instrument of Physical Research, A. McAuley, 423  
 Quatrefores (Prof. de), Death and Obituary Notice of, 278; Proposed Monument to, 612  
 Queensland: Oyster Culture in, Saville-Kent, 66; on the Habits of Ceratodus, the Lung Fish of, Prof. Spencer, 425; Depredations of the Great Bower Bird in, 588  
 Race, the Manchu, 523  
 Radiant Points, Displacement of, Dr. J. Kleiber, 570  
 Rail, New Extinct, Prof. Henry O. Forbes, 416  
 Railway, New, from Upminster to Romford, Essex, T. V. Holmes, 151  
 Railways, English, the Working and Management of, 116  
 Rainbows, Supernumerary, observed in the Orkneys, Robt. H. Scott, F.R.S., 223; M. Spence, 223  
 Rainfall Experiments, Prof. G. Hellmann's Recent, 545  
 Ramsay (Sir Andrew Crombie), Obituary Notice of, 151  
 Ramsay (E. P.), Ethnological Purchases for the Australian Museum, Sydney, 324  
 Ramsay (W.), Pedetic Motion in Relation to Colloidal Solutions, 429  
 Rankin (Angus), Dust Counting on Ben Nevis, 582  
 Raoult (M.), Determination of the Freezing Point of very Dilute Solutions, as Applied to Cane Sugar, 384  
 Rare Phenomenon, a, Alexander Graham Bell, 79  
 Ráthay (Dr.), the Ants attracted by *Cynips calycis*, a Protection to *Quercus pedunculata*, 546  
 Ratzel (Friedrich), Anthropogeographie, 557  
 Rayet (G.), the Temporary Star in Auriga, 408  
 Rayleigh (Right Hon. Lord, F.R.S.): on the Virial of a System of Hard Colliding Bodies, 80; Experiments in Aerodynamics, 108; Superheated Steam, 375; Heat Engines and Saline Solutions, 438, 510; Aberration, 499  
 Reade (T. M.), Drift Beds of North and Mid Wales Coast, 525  
 Realm of Nature, the, Hugh Robert Mill, 390  
 Reboul (E.), Butylene Monobromides, 47  
 Recollections of a Happy Life, being the Autobiography of Marianne North, 602  
 Records of the Australian Museum, 421  
 Recoura (A.), a Green Solid Chromic Sulphate, 192  
 Recreation, Polytechnics and, Miss E. Cons, 28  
 Red Light after Sunset, Dr. M. A. Veeder, 30  
 Red Spot on Jupiter, W. F. Denning, 272  
 Reflection, on Selective and Metallic, A. B. Basset, F.R.S., 119  
 Refractive Power of Cometary Matter, E. E. Barnard, 237  
 Refrigerating Machinery: Prof. Pictet's Laboratory at Berlin Prof. R. du Bois-Reymond, 31  
 Regulation, the Theory of, H. Le Chatelier, 288  
 Regnault (F.), the Foot as a Prehensile Organ in Hindoos, 192  
 Reid (Clement), Natural History of Isolated Ponds, 325; the Pleistocene Deposits of the Sussex Coasts, 454  
 Reinhold, the late Dr., 496  
 Relation of Natural Science to Art, on the, W. Ainslie Hollis, 319  
 Religion, Savage, the Limits of, Dr. Tylor, 71  
 Reliques of Constance Naden, Further, 389  
 Renard (Rev. A. F.), Deep-sea Deposits, 409  
 Respiratory Centres, on the Physiology of, Dr. Alf. Bienfait, 624  
 REVIEWS and OUR BOOK SHELF:—  
 Electricity and Magnetism, translated from the French of Amédée Guillemin, Revised and Edited by Silvanus P. Thompson, F.R.S., Prof. A. Gray, 1  
 Die indo-malayische Strandflora, A. F. W. Schimper, 3  
 Ueber die Mangrove-Vegetation im malayischen Archipel, G. Karsten (Bibliotheca Botanica, Heft 22), W. Botting Hemsley, F.R.S., 3  
 Principles of Political Economy and Taxation, David Ricardo, 4  
 Photographic Pastimes, a Hand-book for Amateurs, Hermann Schnauss, 5  
 On Surrey Hills, by a Son of the Marshes, 5  
 Heroes of the Telegraph, J. Munro, 5  
 An Elementary Hand-book on Potable Water, Floyd Davis, M.Sc., Ph.D., Prof. Percy F. Frankland, F.R.S., 25  
 The Intra-cranial Circulation and its Relation to the Physiology of the Brain, James Cappie, M.D., 26  
 Physiography, Elementary Stage, J. Spencer, 27

## Reviews—continued.

- Mayhew's Illustrated Horse Doctor, Revised and Improved, James Irvine Lupton, 27  
 Handleiding tot de Kennis der Flora van Nederlandsch Indië, Dr. J. G. Boerlage, 28  
 By Seashore, Wood, and Moorland, Peeps at Nature, Edward Step, 28  
 The Ninth Annual Report of the Fishery Board for Scotland, being for the Year 1890, 49  
 Catalogue of Mammalia in the Indian Museum, Calcutta, W. L. Sclater, 50  
 A Text-book of Chemical Physiology and Pathology, W. H. Halliburton, Dr. E. H. Starling, 51  
 Praktisches Taschenbuch der Photographie, Dr. E. Vogel, 51  
 An Introduction to the Differential and Integral Calculus, J. Hugh Miller, 52  
 Star Groups, J. Ellard Gore, 52  
 The Universal Atlas, 52  
 La Transcaucasie et la Péninsule d'Aphéron, Calouste S. Gulbenkian, 52  
 How to Organize a Cruise on the Broads, E. R. Suffling, 52  
 The Electro-magnet and Electro-magnetic Mechanism, S. P. Thompson, F.R.S., Prof. A. Gray, 73  
 British Edible Fungi, how to Distinguish and how to Cook them, M. C. Cooke, 75  
 Psychology: a Short Account of the Human Mind, F. S. Granger, M. A., 76  
 Arithmetical Exercises in Chemistry, Leonard Dobbin, Ph.D., with Preface by Prof. Crum Brown, 76  
 The Colliery Manager's Hand-book, Caleb Pamely, 77  
 Photography Applied to the Microscope, F. W. Mills, 77  
 Copernic et la Découverte du Système du Monde, Camille Flammarion, 77  
 Annals of British Geology, 1890, J. F. Blake, 77  
 Outlines of Field Geology, Sir Archibald Geikie, F.R.S., 97  
 The Land of the Lamas, Notes of a Journey through China, Mongolia, and Tibet, William Woodville Rockhill, 98  
 A Text-book of the Science of Brewing, E. R. Moritz and G. H. Morris, 100  
 Fresh Light on the Dynamic Action and Ponderosity of Matter, "Waterdale," 100  
 Indischer Ozean: Ein Atlas die physikalischen Verhältnisse und die Verkehrs-Strassen darstellend, 101  
 Mechanics for Beginners, Part I., Dynamics and Statics, Rev. J. B. Lock, 101  
 The Physical Geology and Geography of Ireland, Edward Hull, F.R.S., 102  
 The Ouse, A. J. Foster, M.A., 102  
 A Theoretical and Practical Treatise on the Manufacture of Sulphuric Acid and Alkali, George Lunge—Vol. I., Sulphuric Acid, Prof. T. E. Thorpe, F.R.S., 121  
 The Alkali Maker's Hand-book, George Lunge, Ph.D., and F. Harter, Prof. T. E. Thorpe, F.R.S., 121  
 Diphtheria, its Natural History and Prevention, R. Thorne Thorne, F.R.S., 123  
 Bulletin of the New York Mathematical Society, a Historical and Critical Review of Mathematical Science, 124  
 Delagoa Bay, its Natives and Natural History, Rosa Monteiro, 124  
 A Hand-book of Industrial Organic Chemistry, Samuel P. Sadtler, 125  
 Progressive Mathematical Exercises, A. T. Richardson, 125  
 Text-book of Comparative Anatomy, Arnold Lang, Prof. E. Ray Lankester, F.R.S., 145  
 Lehrbuch der Vergleichenden Entwicklungsgeschichte der Wirbellosen Thiere, Dr. E. Korschelt und Dr. K. Heider, Prof. E. Ray Lankester, F.R.S., 145  
 The Artillery of the Future and the New Powders, James Atkinson Longridge, 146  
 The Skeleton of the Irish Giant Cornelius Magrath, Dr. D. J. Cunningham, F.R.S., 147  
 With Axe and Rope in the New Zealand Alps, George Edward Manning, Prof. T. G. Bonney, F.R.S., 147  
 Manual of the Science of Religion, P. D. Chantpie de la Saussaye, translated by Beatrice S. Colyer Fergusson, 148  
 Euclid's Elements of Geometry, Book XI., A. E. Layng, 149  
 Illustrations of the Flora of Japan, to serve as an Atlas to the Nippon-Shokubutsushi, Tomitaro Makino, 149  
 About Ceylon and Borneo, Walter J. Clutterbuck, 149  
 Revisio Genera Plantarum Vascularium omnium, atque

## Reviews—continued.

- Cellularium multarum, secundum Leges Nomenclaturæ Internationales, cum Enumeratione Plantarum in Itinere Mundi collectarum, Dr. Otto Kuntze, 169  
 Thermodynamics of the Steam Engine and other Heat Engines, C. H. Peabody, 172  
 An Account of British Flies (Diptera), Hon. M. Cordelia E. Leigh and F. V. Theobald, 173  
 Principles of Agriculture, R. P. Wright, 173  
 Elementary Trigonometry, J. M. Dyer and Rev. R. H. Whitcombe, 174  
 Solutions, W. Ostwald, translated by M. M. Pattison Muir, 193  
 Colour-blindness and Colour-perception, F. W. Edridge Green, 195  
 Instructions Météorologiques, A. Angot, 196  
 Chambers's Encyclopædia, Vol. VIII., 196  
 La Place de l'Homme dans la Nature, Prof. T. H. Huxley, F.R.S., 197  
 Report on the Meteorology of India in 1889, John Eliot, 217  
 Reports on the Administration of the Meteorological Department of the Government of India, 1885-91, 217  
 Les Coquilles Marines des Côtes de France, Description des Familles et Espèces, A. Locard, 219  
 Nature and Man in North America, N. S. Shaler, 220  
 Stones for Building and Decoration, George P. Merrill, 222  
 Les Champignons, A. Aclouque, 222  
 Theory of Heat, J. Clerk Maxwell, 222  
 The Chemistry of Paints and Painting, A. H. Church, F.R.S., Dr. Hugo Müller, F.R.S., 241  
 Thermodynamique, H. Poincaré, 245  
 Hand-book of the Destructive Insects of Victoria, C. French, 246  
 Farm Crops, John Wrightson, 247  
 Arithmetic for Schools, Charles Smith, 247  
 Journeys in Persia and Kurdistan, Mrs. Bishop (Isabella L. Bird), 248  
 A First Book of Electricity and Magnetism, W. Perren Maycock, 248  
 A Cyclopædia of Nature Teachings, Hugh Macmillan, 248  
 My Personal Experiences in Equatorial Africa as Medical Officer of the Emin Pasha Relief Expedition, T. H. Parke, 265  
 An Introduction to the Theory of Value, William Smart, 268  
 Across Tibet, Gabriel Bonvalot, translated by C. B. Pitman, 269  
 Light, Sir Henry Trueman Wood, 269  
 The Cause of an Ice Age, Sir Robert Ball, Prof. G. H. Darwin, F.R.S., 289  
 Animal Sketches, C. Lloyd Morgan, 291  
 Outlines of Practical Physiological Chemistry, F. C. Larkin and Randle Leigh, 292  
 Problems in Chemical Arithmetic, E. J. Cox, 293  
 The Microscope and its Revelations, the late Dr. Carpenter's, Seventh Edition by Rev. W. H. Dalliger, F.R.S., Prof. E. Ray Lankester, F.R.S., 313  
 Elementary Thermodynamics, J. Parker, 314  
 The Century Dictionary, an Encyclopædic Lexicon of the English Language, William Dwight Whitney, Ph.D., LL.D., 316  
 List of the Snakes in the Indian Museum, W. L. Sclater, 317  
 The Living World, Where it Came and Whither it is Drifting, H. W. Conn, 317  
 Adventures amidst the Equatorial Forests and Rivers of South America, also in the West Indies and the Wilds of Florida, Villiers Stuart, 317  
 Catalogue of Scientific Papers compiled by the Royal Society of London, 338  
 How to Use the Aneroid Barometer, Edward Whympier, 339  
 An Introduction to Human Physiology, Augustus D. Waller, 340  
 Bulletin of the New York Mathematical Society, 341  
 Guide to the Examinations in Chemistry, W. Jerome Harrison, 342  
 Manipulation of the Microscope, Edward Bausch, 342  
 Harrow Birds, G. E. H. Barrett-Hamilton, 342  
 Collection de Mémoires relatifs à la Physique, La Société Française de Physique, Prof. J. J. Thomson, F.R.S., 361  
 Sul Regime delle Spiagge, e sulla Regolazione dei Porti, Signor P. Cornaglia, 362  
 Egypt under the Pharaohs, H. Brugsch-Bey, M. Brodrick, 363

Reviews—continued.

- The Story of the Hills, a Popular Account of Mountains, and how they were made, Rev. H. N. Hutchinson, 364
- The Optics of Photography and Photographic Lenses, J. Traill Taylor, 364
- The Evolution of Life, or Causes of Change in Animal Forms, Hubbard Winslow Mitchell, M.D., 364
- Manual of Chemical Technology, Rudolf von Wagner, translated by William Crookes, F.R.S., 386
- Elements of Agriculture, W. Fream, 388
- Further Reliques of Constance Naden, George M. McCrie, 389
- The Realm of Nature, Hugh Robert Mill, 390
- Grasses of the South-West, Dr. George Vasey, 390
- Sporting Sketches in South America, Admiral Kennedy, 390
- Report on the Scientific Results of the Voyage of H.M.S. Challenger in 1873-76, prepared by the late Sir Wyville Thomson, F.R.S., and John Murray, Prof. J. W. Judd, F.R.S., 409
- British Fungi, Phycomycetes and Ustilaginæ, G. Masee, 411
- A Treatise on the Geometry of the Circle and some Extensions to Conic Sections by the Method of Reciprocation, W. J. McClelland, M.A., 412
- Kalm's Account of his Visit to England on his Way to America in 1748, translated by Joseph Lucas, 412
- Cœuvres Complètes de Christiaan Huygens, A. M. Clerke, 434
- The Horse, a Study in Natural History, William Henry Flower, C.B., F.R.S., 436
- A System of Sight-Singing from the Established Musical Notation, based on the Principle of Tonic Relation, Sedley Taylor, 437
- The Statesman's Year-book for the Year 1892, J. Scott Keltie, 437
- The Optical Lantern as an Aid in Teaching, C. H. Bothamley, 437
- L'Homme dans la Nature, par Paul Topinard, 457
- The Art and Craft of Cabinet Making, D. Denning, 459
- L'Électricité dans la Nature, Georges Dary, 460
- The First Book of Euclid's Elements, Rev. J. B. Lock, 460
- The Ilford Manual of Photography, C. H. Bothamley, 460
- The Advanced Class-book of Modern Geography, William Hughes and J. Francon Williams, 460
- The Theory of Determinants in the Historical Order of its Development, Thomas Muir, 481
- Anthropogenie, oder Entwicklungsgeschichte des Menschen, Prof. Ernst Haeckel, 482
- Philosophical Notes on Botanical Subjects, E. Bonavia, 483
- The Zoological Record for 1890, Frank E. Beddard, 483
- Leçons sur la Pathologie comparée de l'Inflammation faites à l'Institut Pasteur en Avril et Mai, 1891, Elie Metschnikoff, Prof. E. Ray Lankester, F.R.S., 505
- Travels in Africa during the Years 1879-83, Dr. Wilhelm Junker, translated by A. H. Keane, 507
- My Second Journey through Equatorial Africa, Hermann von Wissmann, translated from the German by Minna J. A. Bergmann, 507
- New Fragments, John Tyndall, F.R.S., 508
- A Treatise on Chemistry, Sir H. E. Roscoe, F.R.S., and C. Schorlemmer, F.R.S., 509
- The Oak, a Popular Introduction to Forest Botany, H. Marshall Ward, F.R.S., 509
- The Elements of Plane Trigonometry, R. Levett and C. Davison, 509
- Les Fleurs à Paris, Culture et Commerce, Philippe L. de Vilmorin, 510
- Health Springs of Germany and Austria, F. O. Buckland, 510
- The Principles of Chemistry, D. Mendelëff, translated from the Russian by George Kamensky, and edited by A. J. Greenaway, 529
- A Treatise on the Ligation of the Great Arteries in Continuity with Observations on the Nature, Progress, and Treatment of Aneurism, C. A. Ballance and Walter Edmunds, Dr. M. Armand-Ruffier, 530
- Precious Stones and Gems, their History, Sources, and Characteristics, Edwin W. Streeter, 531
- Air and Water, Vivian B. Lewes, Professor of Chemistry at Royal Naval College, Greenwich, 531

Reviews—continued.

- The Naturalist in La Plata, W. H. Hudson, Dr. Alfred R. Wallace, 553
- A Study of Influenza and the Laws of England concerning Infectious Diseases, Richard Sisley, 556
- Anthropographie, Zweiter Theil, Die Geographische Verbreitung des Menschen, Friedrich Ratzel, 557
- Within an Hour of London Town, among Wild Birds and their Haunts, by a Son of the Marshes, edited by J. A. Owen, 557
- Mission Scientifique de Cap Horn, tome vii., Anthropologie, Ethnographie, P. Hyades et J. Deniker, 577
- Quantitative Chemical Analysis, Frank Clowes and J. Bernard Coleman, 578
- Elementary Mathematical Astronomy, C. W. C. Barlow and G. H. Bryan, 579
- Practical Fruit Culture, J. Cheal, 579
- Blowpipe Analysis, J. Landauer, edited by James Taylor, 580
- Outlines of Theoretical Chemistry, Lothar Meyer, translated by P. Phillips Bedson and W. Carleton Williams, Prof. M. Pattison Muir, 601
- Recollections of a Happy Life, being the Autobiography of Marianne North, edited by Mrs. John Addington Symonds, 602
- Our Trees, John Robinson, 603
- Synopsis of Non-Metallic Chemistry, William Briggs, 604
- Chemical Calculations, R. Lloyd Whiteley, with Preface by Prof. E. Clowes, 604
- The Year-book of Science, edited by Prof. T. G. Bonney, F.R.S., 604
- Handy Atlas of Modern Geography, 605
- Rew (R. Henry), on the Statistics of the Production and Consumption of Milk in Great Britain, 614
- Reynolds (J. E.), Silver Compounds of Thiourea, 383
- Ribbentrop (Dr.), Government Forestry in India, 41
- Ricardo (David), Principles of Political Economy and Taxation, 4
- Rico (A.), Earthquakes at Pantelleria, 120; Account of the Submarine Eruption North-west of Pantelleria, October 1891, Abstract of ditto, G. W. Butler, 584
- Richardson (A. T.), Mathematical Exercises, 125
- Richardson (Dr. B. W., F.R.S.), New Year's Address to Sanitary Inspectors' Association, 234
- Richet (Prof.), Death of, 258
- Richet (Ch.), the Tubercular Vaccination of the Dog, 576
- Rigg (Gilbert), Ice Crystals, 319
- Riley (Dr. C. V.), a New Herbarium Pest, 235
- Ring and Disk Blinds in Micrometric Measurements, on the Influence of, Herr Dr. Walter Wislicenus, 137
- Rings, Atmospheric, Dr. Sprung, 599
- Rivers of Central Europe, the Temperature of, 114
- Roberts (Thomas), Death and Obituary Notice of, 303
- Roberts-Austen (Prof., F.R.S.): the Report to the Alloys Research Committee of the Institution of Mechanical Engineers, 22; Value of Metallurgical Science, 257; Bronze in the London Atmosphere, 443; Metals at High Temperature, 534
- Robertson (W. T.), Tea-culture in New South Wales, 260
- Robinson (Dr. A.) the Formation and Fate of the Primitive Streak in the Frog, 140
- Robinson (John), Our Trees, 603
- Robinson (Margaret), the Nauplius Eye persisting in some Decapods, 450
- Rochester Academy of Sciences, U.S., 588
- Rockhill (William Woodville), the Land of the Lamas, 98
- Rocks collected by M. Lopatin on the Podkameennaya Tunguska, 597
- Rodger (J. W.), Theory of Solutions, 342, 487
- Roemer (the late Ferdinand), Proposed Memorial of, 322
- Rogers (Fred. J.), Magnesium as a Source of Light, 622
- Rolling of Ships, 559
- Romanes (Prof. Geo. J., F.R.S.), Migration of the Lemming, 249
- Rome (Province), Earthquakes in, 304
- Roscoe (Sir H. E., F.R.S.): Action of Water-Gas on Iron, 92; a Treatise on Chemistry, 509
- Rosenberg (Dr.), Assimilation of Diet investigated in a Dog Working on a Treadmill, 599
- Ross (Alexander), Journey to Head Waters of Ecayali, Central Peru, 519

- Ross (W. J. C.), on the Discovery of Two Specimens of Fossil Lepidodendrons in the Neighbourhood of Bathurst, New South Wales, and the Inferences to be drawn from their Occurrence, 424
- Rossiter (E. C.), Sulphochloride of Isomeric Dibromonaphthalene, 263; Action of Alcohols on Sulphonic Chlorides as Means of producing Ethereal Salts of Sulphonic Acids, 263; Action of Bromine on Mixture of Ortho- and Paranitro-acenaphthalide, 263
- Rotation of Jupiter, W. F. Denning, 473
- Rotation of Venus, Herr Loschardt, 210
- Rotch (A. L.), Meteorology of French Association at Marseilles, 189; the Mountain Meteorological Stations of the United States, 403
- Rothamsted, Results of Experiments at, on the Question of the Fixation of Free Nitrogen, Dr. J. H. Gilbert, F.R.S., 32
- Rothney (E. A. J.), Two Species of Indian Ants, 454
- Roumania, the Meteorological Service of, 444
- Rousseau (G.), Manganates of Potash, 288
- Roy (Prof., F.R.S.), Contributions to the Physiology and Pathology of the Mammalian Heart, 451
- Royal Academy of Sciences of Lisbon, Sir Joseph Fayrer, F.R.S., elected Corresponding Member of, 585
- Royal College of Physicians, Sir Andrew Clark elected (fifth time) President, 566
- Royal Geographical Society, 183; Appointment of Mr. J. S. Keltie to the Assistant-Secretaryship in room of late Mr. H. W. Bates, 402; Dr. H. R. Mill appointed Librarian to, 566
- Royal Institution, Lectures at the, 155, 586
- Royal Meteorological Society, 95, 215, 335, 431, 551, 623
- Royal Microscopical Society, 46, 143, 165, 239, 311, 479, 574
- Royal Military Academy, Science at the, 563
- Royal Scottish Geographical Society, Branch established in London, 544
- Royal Society, 37, 141, 162, 190, 212, 311, 357, 381, 407, 429, 451, 549, 573; Anniversary Meeting, 110; Sir William Thomson's Anniversary Address, 110; Medallists, 111; Officers and Council, 112; Catalogue of Scientific Papers, 338
- Royal Society of New South Wales, 95; Prizes Offered by, 443; Award of Clarke Memorial Medal to Mr. W. T. Thiselton-Dyer, 495
- Royal Statistical Society, R. Henry Rew on the Statistics of the Production and Consumption of Milk in Great Britain, 614
- Rubens (Dr.): New Method of Determining Dispersion and Refraction in Ultra-Violet Rays, 48; the Dispersion of the Ultra-Red Rays, 576
- Rubi, Alpine, T. D. A. Cockerell, 320
- Rücker (Prof., F.R.S.): Royal Society Medallist, 111; Speech at the Royal Society Dinner, 112
- Ruffer (Dr. M. Armand), a Treatise on the Ligation of the Great Arteries in Continuity, with Observations on the Nature, Progress, and Treatment of Aneurism, Charles A. Ballance and Walter Edmunds, 530
- Rugby School Natural History Society, 520
- Runge (Prof. C.), on the Line Spectra of the Elements, 607
- Russell (F.) Results of Meteorological Observations at Akassa, 95
- Russell (H. C., F.R.S.), the Grouping of Stars in the Southern Part of the Milky Way, 423
- Russell (H. L.), the Effect of Mechanical Movement on the Growth of Certain Plants, 478
- Russell (Prof. Israel C.): Cirques, 317; Geographical Position of Mount St. Elias, 472
- Russell (J. S. R.), the Abductor and Adductor Fibres of the Recurrent Laryngeal Nerve, 573
- Russell (Lucy J.), Bedford College and the Gresham University, 391
- Russell (Hon. Rollo), Untenability of Atmospheric Hypothesis of Epidemics, 431
- Russell (Dr. W. J., F.R.S.): Town Fogs and their Effects, 10; Bedford College and the Gresham University, 391
- Russia: the Grain Production of, Borkovsky, 67; Russian Geographical Society, 92; Awards, 444; European, Frequency and Geographical Distribution of Heavy Daily Rainfall in Russia, E. Berg, 258; Mercury Mining in, 305; Causes of the Famine in, Dr. A. Woeikof, 378; Russian Prehistoric Antiquities, the Slavonians of the First Centuries of our Era, Prof. Samokvasoff, 547; Sunflower Cultivation in Southern Russia, 568
- Rust Fungus in Wheat, 615
- Rusting of Iron, A. Liversidge, F.R.S., on the, 424
- Rutherford's Photographs, Catalogue of, 21
- Sabatier (Paul), Sulphides and Selenides of Boron and Silicon Selenide, 41
- Sacken (C. R. Osten), *Meretrix*, Lamarck 1799, *versus Cytherea*, Lamarck 1806, 30
- Sadtler (Samuel P.), a Hand-book of Industrial Organic Chemistry, 125
- Saffard (Truman), on the Observation of North Polar Stars in the Vertical of Polaris, 159
- St. Malo Bay, the Tides of, M. Heurtault, 143
- St. Petersburg Electrical Exhibition, 303
- St. Thomas's Hospital, Lectures on Systematic Botany at, 586
- Saline Solutions, Heat Engines and, Lord Rayleigh, F.R.S., 438, 510
- Salmon Industry in British Columbia, 279
- Salt Lake of Aalia Paakai, A. B. Lyons, 29
- Salts in Natural Waters, 78; F. H. Perry Coste, 176; Robert B. Hayward, F.R.S., 176
- Samoa Cyclone of March 16, 1889, 161
- Samoa Hurricane, Everett Hayden, 461
- Samokvasoff (Prof.) the Slavonians of the First Centuries of our Era, 547
- Sanderson (Prof. J. Burdon, F.R.S.), Obituary Notice of Sir William Bowman, 564
- Sandwich Islands, Mr. R. C. L. Perkins Selected to Investigate the Zoology of the, 322
- Sandwich Isles, Ornithology of the, Prof. Alfred Newton, F.R.S., 465, 532; Albert F. Calvert, 485, 558; J. E. Harting, 532
- Sanitary Conference, International, 233
- Sanitary Engineering, C. Napier Bellon, 426
- Sanitary Inspectors' Association, New Year's Address, Dr. B. W. Richardson, F.R.S., 234
- Sanitation in Schools, 185
- Sapper (Dr.), the Climate of Alta Verapaz, 41
- Sardine, Growth of the Pilchard or, Prof. J. T. Cunningham, 255
- Sardinia, the Nurhagi of, Dr. Erlming, 114
- Sarro Savages, Arrow-Poison of, Laborde and Rondeau, 278
- Saussure (P. D. Chantpie de la), Manual of the Science of Religion, 148
- Saville-Kent (W.), Oyster-Culture in Queensland, 66
- Scandinavia, Chronology of the Neolithic Age in, Prof. Montelius, 39
- Scheele (Carl Wilhelm), Letters and Memoirs of, 207
- Scheurer-Kestner (M.), Decomposition of Sulphurous Acid by Water at very High Temperatures, 384
- Schimper (A. F. W.), Die indo-malayische Strandflora, W. Botting Hemsley, F.R.S., 3
- Schlesing (Th., Jun.), the Fixation of Free Nitrogen by Plants, 143
- Schnauss (Hermann), Photographic Pastimes, a Hand-book for Amateurs, 5
- Schoetensack (Dr. O.), the Nephrite Axe found at Ohlau, Silesia, 379
- Schorlemmer (C., F.R.S.), a Treatise on Chemistry, 509
- Schorr (Dr. R.), Denning's Comet (*6* 1892), 569
- Schoute (Prof.): Lemoine's Two Problems of Stamps, 72; the Stamp-folding Problem, 335
- Schweizer (Dr.), the Behaviour of Spermatozoa towards Electric Currents, 599
- Science: Electricity in Relation to, Prof. W. Crookes, F.R.S., 63; Examinations in, 85; Elizabeth Thompson Science Fund, 91; a Text-book of the Science of Brewing, E. R. Moritz and G. H. Morris, 100; Scientific Nomenclature, H. St. A. Alder, 104; Manual of the Science of Religion, P. D. Chantpie de la Saussure, 148; Implications of Science, Dr. St. George Mivart, F.R.S., 60, 82, 222, 343; Edward T. Dixon, 125, 272, 391; Miss E. E. C. Jones, 223, 366; on the Relation of Natural Science to Art, Prof. E. du Bois-Reymond, F.R.S., 200, 224; Science in Japan, Prof. E. Ray Lankester, F.R.S., 256; Royal Society Catalogue of Scientific Papers, 338; Science Museum and Gallery of British Art at South Kensington, 348; Science Museum and the Tate Gallery, 385, 433; Forthcoming Scientific Books, 476; Science at the Royal Military Academy, 563; the New York "Scientific Alliance," 544; the Year-book of Science, 1891, Prof. T. G. Bonney, F.R.S., 604

- Slater (Dr. P. L., F.R.S.), Opportunity for a Naturalist, 174, 269
- Slater (W. L.), Catalogue of Mammalia in the Indian Museum, Calcutta, 50
- Scotland, the Ninth Annual Report of the Fishery Board for, 49
- Scotland, Technical Education in, 377
- Scott (Ernest), Electricity in Relation to Mining, 184
- Scott (Robt. H., F.R.S.): Supernumerary Rainbows observed in the Orkneys, 223; Atlantic Weather and its connection with British Weather, 496
- Scottish Meteorological Society, 470
- Scottish Zoology, Prof. Cossar Ewart on, 17
- Scripture (E. W.), the Study of Psychology as a Science in the United States, 568
- Scudder (F.), Action of Water Gas on Iron, 92
- Sea, Cloud-Observations at, Prof. C. Abbe, 70
- Sea-borne Sediment, the Precipitation and Deposition of, R. G. Mackley Browne, 598
- Sea-Fish, Destruction of Immature, Alfred O. Walker, 176; Ernest W. L. Holt, 240
- Sea-Serpent, Dr. A. C. Oudemans on the, 614
- Sea-shore, Wood, and Moorland, By, Edward Step, 28
- Seabrook (Geo. M.), Aurora, 605
- Search Light, Working of the, W. B. Lefroy Hamilton, 587
- Searle (G. F. C.), an Experiment of Sir Humphry Davy's, 47
- Seaside Plants, Biology of, W. Botting Hemsley, F.R.S., 3
- Secular Acceleration of the Moon and the Length of the Sidereal Day, 137
- Secular Variation of Latitudes, 210
- Seeborn (H.), White's Thrush (*Turdus varius*), 479
- Seemann (Herr), a Weather Lexicon, 208
- Segers (M.), Mussel-Poisoning in Tierra del Fuego, 134
- Seismometry and Engineering in Relation to the Recent Earthquake in Japan, Prof. John Milne, F.R.S., 127
- Seismology: Earthquake at Nipon, Japan, 19; Earthquake in Japan, 86, 199; Seismology in Japan, 471; Seismological Phenomena in Australasia, 423; Earthquake at Nicaragua, 471; at Portland, Oregon, 586; Earthquake at California, 471, 614 (see also Earthquakes)
- Selection, Topical, and Mimicry, David Syme, 30; Dr. Alfred R. Wallace, 30
- Selective and Metallic Reflection, A. B. Basset, F.R.S., 119
- Self-registering Weathercock, J. Lawrence Hamilton, 559
- Sellers (Coleman), American Superiority in Mechanics, 157
- Sendall's (Sir W. J.) Apparatus for making Accurate Measurements with Camera Lucida, 46
- Sensitive Water Jets, W. B. Croft, 606
- Shaler (Prof. N. S.), Nature and Man in North America, 220
- Shark, Large Greenland, Stranded at Lynn, T. Southwell, 546
- Sharp (Dr.), on the Phyllium, 623
- Shaw (Jas.), Peculiar Eyes, 104
- Sheep, Origin of the, in China, Dr. Macgowan, 285
- Sherman (O. T.), Zodiacal Light, 381
- Sherwood (William), Striated Surface under the Cromer Drift, 511
- Shields, Ancient Menches, Zelia Nuttall, 520
- Shipbuilding: the Steadying of Vessels at Sea, J. T. Thornycroft, 570; the Influence of Shallow Water upon the Trial Trip Speeds of Modern Vessels, W. H. White, F.R.S., 571; on Balancing Marine Engines and the Vibration of Vessels, A. F. Yarrow, 571
- Ships, Rolling of, 559
- Shipleigh (A. E.), *Onchomesoma Steenstrupii*, 450
- Shore (Dr.), Action of Lymph in Producing Intravascular Clotting, 455
- Shufeldt (Dr.): Prints of Havesu-pai Indians, 235; Weaving as Practised by the Navajo Indians, 260
- Sidereal Day, the Secular Acceleration of the Moon and the Length of the, 137
- Sidgreaves (Rev. Walter), Stonyhurst Drawings of Sun-spots and Faculae, 261
- Siemens and Halske, Experiments on the Production of Ozone by Electric Silent Discharge, 39
- Sierra Leone Anglo-French Frontier Delimitation Commission, the, 64; Government Mission to Investigate Botany of, 64
- Sight, Motion of Stars in the Line of, Prof. H. C. Vogel, 280
- Sight-singing from the Established Musical Notation, a System of, based on the Principle of Tonic Relation, Sedley Taylor, 437
- Silk Insects of India, the Wild, E. C. Cotes, 520
- Silk-producing Moths, Col. Swinhoe, 38
- Simla, Capt. Bowser's Journey from China to, 615
- Sinclair (F. G.), a New Mode of Respiration in the Myriapoda, 164
- Singer (Dr.), Cloud Pictures, 518
- Sirius System, the, Dr. A. Auwers, 617
- Sisley (R.), a Study of Influenza and the Laws of England concerning Infectious Diseases, 556
- Skate, the Electric Organ of the, Prof. J. G. Ewart, 451
- Skinner (S.), Some Notes on Clark's Cells, 47; Properties of Alcoholic and other Solutions of Mercuric and other Chlorides, 430
- Skea in Shetland, the Great, W. E. Clarke, 545
- Slater (Chas.), the Differentiation of Leprosy and Tubercle Bacilli, 450
- Slater's (Prof. J. S.) Improved Armillary Sphere, 134
- Slavonians of the First Centuries of our Era, the, Prof. Samokvasoff, 547
- Sleep: Causation of, James Cappie, M.D., 26; Peculiar Case of Prolonged, 323, 349
- Smart (William), an Introduction to the Theory of Value, 268
- Smith (Charles), Arithmetic for Schools, 247
- Smith (Fred. J.), a Simple Heat-Engine, 294, 464
- Smith (W. W.), Hellebore as an Insecticide, 546
- Smithells (A.): Structure and Chemistry of Flames, 214; Structure of Luminous Flames, 214
- Smithells (Prof.), Origin of Flame Coloration, 306
- Smithsonian Institution: Gift by Mr. Thomas Hodgkins to, 37; Prof. S. P. Langley's Report for the Year, 261
- Smithsonian Standards for Physical Apparatus, Prof. S. P. Langley, 197
- Snakes in the Indian Museum, List of the, W. L. Slater, 317
- Snow-Sweeper, Electric, 39
- Snowstorms, Severe, in the Channel Islands and South of England, 586
- Société de Biologie, Prof. A. Chauveau elected President of the, 612
- Society of Arts, Lecture Arrangements, 19
- Solar Activity, State of, Prof. Tacchini, 137
- Solar Activity in 1891, Rodolf Wolf, 307
- Solar Disturbances of 1891, June 17, H. H. Turner, 404
- Solar Heat, Dr. Joseph Morrison, 589
- Solar Investigation, Prof. Hale, 473
- Solar Observations, Prof. Tacchini, M. Marchand, 352
- Solar Parallax, Determination of the, A. Auwers, 89
- Solar Prominences: Measurement of, M. Fizeau, 422; Photography of, Prof. G. E. Hale, 326; M. Deslandres, 404, 522
- Sollas (Prof., F.R.S.), the Basal Conglomerate of Howth, 455
- Solomon Islands, Collection of Dried Plants from the, 586
- Solutions: Prof. W. Ostwald, 193, 293, 415, 606; J. W. Rodgers, 487, 342
- Somaliland, Skin of Grevy's Zebra brought from, 598
- Sorby (Dr.), True Relation of Technical Education to Study of Pure Science, 38
- Sound, a Lecture Experiment on, Reginald G. Durrant, 415
- South America: Adventures amidst the Equatorial Forests and Rivers of, Villiers Stuart, 317; Sporting Sketches in, Admiral Kennedy, 390; Aberrant Fossil Ungulates of, 608
- South Kensington, the Science Museum and Gallery of British Art at, 348
- South-West, Grasses of the, Dr. George Vasey, 390
- Southwell (T.), Large Greenland Shark Stranded at Lynn, 546
- Sowerby (William), Intermediate Forms of Azaleas, 519
- Spanish Quatercentenary Exhibition of Discovery of America, Projected, 64
- Sparrows and Crows, B. McLachlan, F.R.S., 441
- Spectrum Analysis: Dr. Müller on the Telluric Spectrum, 21; Note on the Chromosphere Spectrum, Prof. C. A. Young, 28; the Chromosphere Line Angström 6676.9, 103; the Chromosphere Line  $\lambda$  6676.9, Prof. C. A. Young, 198; New Method of Determining Dispersion and Refraction in Ultra-Violet Rays, Dr. Rubens, 48; Spectra of the Sun and Metals, F. McClean, 159; Analysis of Spectrum of Sodium, Dr. G. J. Stoney, F.R.S., 166; Stars having Peculiar Spectra, Prof. Pickering, 210; a New Spectrometer, C. Féry, 239; Spectrum of Iron and the Periodic Law, John Parry, 253; Colour and Spectrum of Free Gaseous Fluorine, M. Moissan, 260; Observations of the Spectrum of Nova Aurigæ, 345; Dr.

- Henry Crew, 569; J. Norman Lockyer, F.R.S., 429; E. W. Maunder, 619; the Curves of Luminosity under very Feeble Illumination, Prof. König, 432; the Lick Spectroscope, 473; Researches on Samarium, Lecoq de Boisbaudran, 504; Periodic Heat Maxima observed in Spectra from Flint and Crown Glass and Rock-salt, M. Aymonnet, 504; the Aurora Spectrum, Prof. Hale, 522; the Spark Spectra of Gallium, Lecoq de Boisbaudran, 575; on the Line-Spectra of the Elements, Prof. C. Runge, 607
- Spence (M.), Supernumerary Rainbows observed in the Orkneys, 223
- Spencer (J.), Physiography, Elementary Stage, 27
- Spencer (Prof. W. Baldwin); on the Habits of *Ceratodus*, the Lung Fish of Queensland, 425; on the Fresh-water and Terrestrial Fauna of Tasmania, 425
- Spermatozoa, the Behaviour of, towards Electric Currents, Dr. Schweizer, 599
- Sphere, Prof. J. S. Slater's Improved Armillary, 134
- Spitta (Dr. E. J.), Law of Limiting Apertures, 186
- Sponge Trade of the Bahama Islands, 20
- Sponges, Fresh-water in the Buffalo Bay and Niagara Region, Dr. Kellicott, 305
- Sporting Sketches in South America, Admiral Kennedy, 390
- Spot, the Red, on Jupiter, W. F. Denning, 272
- Spring (Prof.), the Late Prof. Stas's "Silver" (the Results of further Stöchiometrical Investigations), 497
- Sprung (Dr.), Atmospheric Rings, 599
- Squirrels in Winter, C. Fitzgerald, 136
- Stage, Electricity on the, 259
- Standards of Measure and Weight immersed in the Houses of Parliament, Examination of the, 543
- Stanton (T. W.), the Stratigraphic Position of the Bear River Formation, 450
- Starling (Dr. E. H.): an Introduction to Human Physiology, Augustus D. Waller, 340; a Text-book of Chemical Physiology and Pathology, W. D. Halliburton, 51
- Stars: Proper Motions of the Stars, W. H. S. Monck, 8; the Motion of Stars in the Line of Sight, Prof. J. Norman Lockyer, F.R.S., 117; Prof. H. C. Vogel, 280; Star Groups, J. Ellard Gore, 52; on the Observation of North Polar Stars in the Vertical of Polaris, Truman Saffard, 159; Stars having Peculiar Spectra, Prof. Pickering, 210; New Star in the Milky Way, Ralph Copeland, 325; Observations of Nebulæ and Star-Clusters, M. Bigourdan, 352; the New Star in Auriga, 344, 366; Thos. D. Anderson, 365; G. Rayet, 408; J. Norman Lockyer, F.R.S., 429, 473; Herren Eugen and Gothard, 473; S. W. Burnham, 473; H. C. Vogel, 498; Astronomer-Royal of Scotland, 454, 527; Photographic Magnitudes of Stars, 380; the Grouping of Stars in the Southern Part of the Milky Way, H. C. Russell, F.R.S., 423; Fuzziness of some Variable, Cuthbert G. Peck, 497; the Relative Motion of 61 Cygni, Prof. A. Hall, 547
- Stas (Prof.), Death of, 154
- Stas's (the late Prof.) "Silver" (the Results of further Stöchiometrical Investigations), Prof. Spring, 497
- Statesman's Year-book for the year 1892, J. Scott Keltie, 437
- Statistics of Population of the Five Continents, E. Levasseur, 552
- Statistics of the Production and Consumption of Milk in Great Britain, R. Henry Rew, 614
- Statistics of Surface and Population of European States, Émile Levasseur, 528
- Steam, Superheated, Lord Rayleigh, Sec. R.S., 375; J. Macfarlane Gray, 413, 486; Prof. James A. Cotterill, F.R.S., 414; G. H. Bailey, 414; John Gamgee, 438
- Steam-Engine, Thermodynamics of the, and other Heat-Engines, Cecil H. Peabody, Prof. A. G. Greenhill, F.R.S., 172
- Stearns (Robert E. C.), Conchology of the West Coast of South America, 89
- Steel, Microscopic Structure of Hard, Behrens, 48
- Steen (Herr), Influence of Total Solar Eclipse on Air-Pressure, 444
- Stejneger (L.), Enormous American Lizard, 40
- Stellar Aberration, Lord Rayleigh, Sec. R.S., 499
- Stellar Photography, a Shutter for use in, J. July, 167
- Stellar Spectra, Distribution of Energy in, Prof. Pickering, 159
- Stellar Spectra, the Draper Catalogue of, A. Fowler, 426
- Step (Edward), By Sea-shore, Wood, and Moorland, Peeps at Nature, 28
- Stirling (James), Hydrology of the Mitta Mitta, 40
- Stirling (Dr.), New Australian Animal (*Notoryctes typhlops*), J. D. Ogilby, 135
- Stockholm Natural History Museum, Prof. Svén Lovén's Resignation of his Position as Senior Keeper in the, 613
- Stokes (Sir G. G., F.R.S.): the Interactions occurring in Flames, 430; on an Optical Proof of the Existence of Suspended Matter in Flames, 133
- Stokvis (Prof.) on Mutual Antagonism, 72
- Stones for Building and Decoration, Geo. P. Merrill, 222
- Stones, Precious, and Gems, their History, Sources, and Characteristics, Edwin W. Streeter, 531
- Stoney (Dr. G. Johnstone, F.R.S.): Analysis of Sodium Spectrum, 166; proposed Standard Gauge, 598
- Stonyhurst Drawings of Sun-spots and Faculæ, Rev. Walter Sidgreaves, 261
- Storm, Magnetic, of February 13-14, 1892, 493
- Storms, Magnetic, Dr. M. A. Veeder, 557
- Storms, Winter, of Northern India, Henry F. Blanford, F.R.S., 490
- Story of the Hills, Rev. H. N. Hutchinson, 364
- Streeter (Edwin W.), Precious Stones and Gems, their History, Sources, and Characteristics, 531
- Strength, the Limpet's, J. Lawrence Hamilton, 487
- Striated Surface under the Cromer Drift, William Sherwood, 511
- Struthion Birds of Australasia, on the Origin of the, Prof. Hutton, 425
- Struts and Tie-rods laterally loaded, Prof. J. Perry, F.R.S., 192
- Struve (H.), Two New Laws of Celestial Mechanics, 70
- Stuart (Prof. T. P. Anderson): the Mechanism of the Closure of the Larynx, 357; Exchange of Professional Duties, Prof. E. Ray Lankester, F.R.S., 557
- Stuart (Villiers), Adventures amidst the Equatorial Forests and Rivers of South America, 317
- Submarine Eruption North-west of Pantelleria, October 1891, on the Matter thrown up during the, General W. Butler, Geo. H. Perry, 251; Abstract of Mr. A. Ricco's Account of the, G. W. Butler, 584
- Suffling (E. R.), How to Organize a Cruise on the Broads, 52
- Sugar in Blood, Note on the Behaviour of, Dr. Vaughan Harley, 497
- Sulphur, Decomposition of, Tested Electrolytically, Dr. Gross, 599
- Sulphuric Acid, the Manufacture of, George Lunge, Ph.D., Prof. T. E. Thorpe, F.R.S., 121
- Sumatra, Java, &c., Fresh-water Fauna of, Prof. Max Weber, 408
- Sumptan and Bow in Indonesia, Use of the, C. M. Pleyte, 235
- Sun: the Temperature of the, M. H. Le Chatelier, 547; Sun Pillar, Annie Ley, 484; Spectra of the Sun and Metals, F. McClean, 159; Sun-spots and Air Temperature, 271; Stonyhurst Drawings of Sun-spots and Faculæ, Rev. Walter Sidgreaves, 261; Sun-spots of February, 446; Red Light after Sunset, Dr. M. A. Veeder, 30
- Sunday Lecture Society, 116
- Sunflower Cultivation in Southern Russia, 568
- Sunflower, Biology of the, A. Gordyaghin, 597
- Superheated Steam, Lord Rayleigh, Sec. R.S., 375; J. Macfarlane Gray, 413, 486; Prof. James A. Cotterill, F.R.S., 414, G. H. Bailey, 414; John Gamgee, 438
- Supernumerary Rainbows observed in the Orkneys, Robt. H. Scott, F.R.S., 223; M. Spence, 223
- Surface Tension, a Lecture Experiment in, E. D. Fridlander, 463
- Surgery: on the implanting of Large Pieces of Decalcified Bone to fill up Losses of Substance of Skeleton, Le Dentu, 95
- Surrey Hills, on, by a "Son of the Marshes," 5
- Suspended Matter in Flames, on an Optical Proof of the Existence of, Sir G. G. Stokes, F.R.S., 133
- Swan's Secret, a, Mrs. Jessie Godwin-Austen, 416
- Swift (Dr. Lewis): some Apparently Variable Nebulæ, 261; Variability of Nebulæ, 522; a New Comet Discovered by, 446; Swift's Comet, March 6, 548; Comet Swift, 1892, 569
- Swinhoe (Colonel), Silk-producing Moths, 38
- Sydney: Discoloration of Water in Port Jackson by Minute Marine Organisms, 184
- Sydney: Ethnological Purchases for the Australian Museum, E. P. Ramsay, 325; Fruit-growers' Conference at, 420
- Sydney, Royal Society of New South Wales, 311

- Sydney University, the Demonstrator of Chemistry at, 19  
 Syme (David), Topical Selection and Mimicry, 30  
 Symons (G. A.), Phenomenal Barometrical Depression  
 (November 11, 1891), 65  
 Tacchini (Prof.), State of Solar Activity, 137; Solar Observations, 352  
 Tait (Prof. P. G.): on the Virial Equation for Gases and Vapours, 199; the Isothermals of Mixtures of Gases, 431; the Relation between Kinetic Energy and Temperature in Liquids, 455  
 Taannin, the Mangrove as a Source of, Dr. J. T. Rothrock, 546  
 Tarr (R. S.), the Permian of Texas, 310  
 Tasmania, on the Freshwater and Terrestrial Fauna of, Prof. W. Baldwin Spencer, 425  
 Tate Gallery, the Science Museum and the, 385, 433  
 Taurus, the Eastern, and the Anti-Taurus, D. G. Hogarth, 138  
 Taylor (A. J.), the Ouse, 102  
 Taylor (J. Traill), Optics of Photography and Photographic Lenses, 364  
 Taylor (Sedley), a System of Sight-singing from the Established Musical Notation, based on the Principle of Tonic Relation, 437  
 Tea-Culture in New South Wales, W. T. Robertson, 260  
 Teaching, the Optical Lantern as an Aid in, C. H. Bothamley, 437  
 Teall (J. J. H., F.R.S.), the Plutonic Rocks of Garabal Hill and Meall Breac, 360  
 Technical Education : the Speaker of the House of Commons on, 19; Technical Education in Essex, 243, 613; in Scotland, 377; in London, 403; the New London County Council and, 566; Technical Education for Novelists, 487  
 Technology, Photography as a Branch of, Prof. R. Meldola, F.R.S., 331  
 Tegetmeier (W. B.), Utilization of Homing Pigeons, 320  
 Telegraph, Heroes of the, J. Munro, 5  
 Telegraphic Connection with the Bahama Islands, 114  
 Telephone Installation at Adelphi Hotel, Liverpool, 184  
 Telescopic Objectives, A. Fowler, 204  
 Telluric Spectrum, Dr. Müller on the, 21  
 Tempel-Swift's Periodic Comet, 21  
 Tempel-Swift Comet, 159  
 Temperature, Changefulness of, as an Element of Climate, 610  
 Temperature in Europe, Research on Extremes of, Dr. Lachmann, 576  
 Temperature, Metals at High, Prof. W. C. Roberts-Austen, F.R.S., 534  
 Temperature of the Sun, the, M. H. Le Chatelier, 547  
 Tenasserim River, Discovery of Coal on, 496  
 Tension, a Lecture Experiment in Surface, E. D. Fridlander, 463  
 Terne (Dr. B.), the Utilization of the By-products of the Coke Industry, 157  
 Tertiary Silicified Woods of Eastern Arkansas, R. Ellsworth Call, 119  
 Tesla (Nikola), Lectures on Alternate Currents of High Potential and Frequency, 345  
 Theobald (F. V.), an Account of British Flies (Diptera), 173  
 Theory of Solutions, Prof. W. Ostwald, 293, 415; J. W. Rodger, 342, 487  
 Thermodynamics : Thermodynamics of the Steam Engine and other Heat Engines, Cecil H. Peabody, Prof. A. G. Greenhill, F.R.S., 172; a Simple Heat Engine, Fred. J. Smith, 294; Elementary Thermodynamics, J. Parker, 314; the Thermal Conductivities of Crystals and other Bad Conductors, C. H. Lees, 382; Poincaré's Thermodynamics, Prof. H. Poincaré, 245, 414, 439, 485, 532; Thermodynamic View of Action of Light on Silver Chloride, H. W. Elder, 524  
 Thermometer, a Compensated Air-, H. L. Callendar, 212  
 Thermometers, the Change of Zero of, C. T. Heycock, 526  
 Thielston-Dyer (W. T., F.R.S.): University of London, 329; Award by Royal Society of New South Wales of Clarke Memorial Medal to, 495  
 Thomas (R. Haig), a Plague of Small Frogs, 8  
 Thompson (Elizabeth), Science Fund, 91  
 Thompson (E. E.), the Prairie Larks and Cranes of Manitoba, 135  
 Thompson (J. O.), the Law of Elastic Lengthening, 311  
 Thompson (Prof. S. P., F.R.S.): Electro-Magnetism, Prof. A. Gray, 73; Supplementary Colours, 452; Modes of Representing Electromotive Forces and Currents in Diagrams, 478  
 Thomson (D.), the Prolongation of the Gooseberry Season, 157  
 Thomson (Prof.), some Experiments on Electric Discharge, 526  
 Thomson (Prof. J. J., F.R.S.), Collection de Mémoires Relatifs à la Physique, 361  
 Thomson (Principal J. L.), Olive-culture in Australia, 135  
 Thomson (J. P.), on Recent Explorations and Discoveries in British New Guinea, 425  
 Thomson (Sir William, F.R.S.): Portrait of, 113; Peerage conferred on, 233  
 Thorne (R. Thorne, F.R.S.), Diphtheria, its Natural History and Prevention, 123  
 Thornycroft (J. I.), the Steadying of Vessels at Sea, 570  
 Thorpe (Prof. T. E., F.R.S.): Dr. George Lunge on the Manufacture of Sulphuric Acid, 121; the Alkali Maker's Handbook, by Dr. George Lunge and Dr. F. Hurter, 121; Phosphorus Oxide, ii., 213; Frangulin, ii., 214; Obituary Notice of Hermann Kopp, 441; Lecture Experiment to illustrate Phenomena in Coal-Dust Explosion, 551  
 Thraen (Herr Dr.), Wolf's Comet, 1891 II., 548  
 Throwing-Sticks, Eskimo, Prof. O. T. Mason, 66; Agnes Crane, 103  
 Thurston (Edward), on the Fall of Meteorites in Madras, 20  
 Thibet, Across, Gabriel Bonvalot, 269  
 Tibet Expedition, General Petzoff, 45  
 Tides of St. Malo Bay, the, M. Heurtault, 143  
 Tierra del Fuego, Mussel Poisoning in, M. Segers, 134  
 Tilden (W. A.), Limettin, 453  
 Tin Mining in Mergui, 496  
 Titchener (E. B.): Comparative Palatability, 53; Peculiar Eyes, 177  
 Tittmann (O. H.), C.G.S. System of Units, 581  
 Tobacco, the Insect &c. Enemies of, Prof. Tozzetti, 325  
 Tokyo Botanical Magazine, 46  
 Tomb, Prehistoric, in Ohio, Discovery of Remarkable, 157  
 Tombs, Ancient, and Burial Mounds of Japan, Prof. Hitchcock, 381  
 Tomlinson (Herbert, F.R.S.), the Aneroid in Hypsometry, 440  
 Tonganoxie Meteorite, E. H. S. Bailey, 119  
 Topical Selection and Mimicry, David Syme, 30; Dr. Alfred R. Wallace, 30  
 Topinard (Paul), the Transformation of the Animal Skull into a Human Skull, 260  
 Topinard (Paul), L'Homme dans la Nature, 457  
 Topley (W.), Obituary Notice of Dr. T. Sterry Hunt, 400  
 Tornado in N.W. States of North America, 545  
 Torpid Cuckoo, A. Holte Macpherson, 416  
 Tortoise Enclosed in Ice, a, Frank Finn, 320  
 Tower of Babel and the Confusion of Tongues, the, Thos. G. Pinches, 210  
 Town Fogs and their Effects, 53; Dr. W. J. Russell, F.R.S., 10  
 Tozzetti (Prof. A. T.), the Insects &c. that Injure Tobacco, 325  
 Trajectories of Elongated Projectiles, Calculation of, Rev. F. Bashforth, 473  
 Transcaucasia and la Péninsule d'Aphéron, la, Calouste S. Gulbenkian, 52  
 Transit Circles, N.P.D.'s Observed with Greenwich and Washington, Prof. Newcomb, 548  
 Transit Observations, Personal Equations in, 617  
 Transvaal, Southern, Geology of the Gold-bearing Rocks of the, Walcot Gibson, 598  
 Travaux de la Société des Naturalistes de St. Pétersbourg, 141  
 Travels of a Painter of Flowers, 602  
 Trees, Our, John Robinson, 603  
 Trigonometry, Elementary, Rev. R. H. Whitcombe and J. M. Dyer, 174  
 Trigonometry : the Levels, J. A. C. Oudemans, 240  
 Trigonometry, the Elements of Plane, R. Levett and C. Davison, 509  
 Trinity College, Dublin, Tercentenary Celebration of, 378  
 Tropical Sea-side Plants, W. Botting Hemsley, F.R.S., 3  
 Trouton (Fred. T.), some Experiments made with the View of Ascertaining the Rate of Propagation of Induced Magnetism in Iron, 42  
 Trow (A. H.), a Difficulty in Weismannism, 102, 175  
 Trowbridge (John), a Phasemeter, 622  
 True (F. W.), the Puma, 445  
 Tuberculosis, the Vaccination of the Dog against, Héricourt and Richet, 576

- Tudor Specimen of Eozoon, J. W. Gregory, 486  
 Turner (F.), the Acclimatization of the Avocado Pear in New South Wales, 66  
 Turner (H. H.), Solar Disturbances of 1891, June 17, 404  
 Turner (Sir W.), the Lesser Rorqual Whale, 454  
 Tutton (A. E.): Iron Carbonyl from Water Gas, 36; Further Researches upon Azoimide, N<sub>2</sub>H, 127; Phosphorous Oxide, ii., 214; Phosphorous Oxide, 446; the Properties of Amorphous Boron, 522  
 Tyler (Dr. E. B.): the Limits of Savage Religion, 71; the Bow as Origin of Stringed Instruments, 184  
 Tyndall (John, F.R.S.), New Fragments, 508  
 Typological Museums, General Pitt-Rivers, 184  
 Tyrell (J. B.), Geology of Lake Winnipeg, 115
- Ungulates of South America, Aberrant Fossil, 608  
 Umney (J. C.), the Aconite Alkaloids, ii., 525  
 United States: Weather Bureau of the, 86; Education in, 156; Production of Pig-Iron in, John Birkinbine, 208; the Paper-making Industry in the, J. F. Hobart, 279; U.S. Naval Observatory, Report of, 352; the Mountain Meteorological Stations of the United States, A. L. Rotch, 403; the Study of Psychology as a Science in the United States, E. W. Scripture, 568  
 Units, C.G.S. System of, O. H. Tittmann, 581; Prof. J. D. Everett, F.R.S., 581  
 Universal Atlas, the, 52  
 Universities in Australia, Prof. Morris on, 426  
 Universities, Functions of, Prof. Geo. Fras. Fitzgerald, F.R.S., 513  
 University College, London, Proposed Extension of Physical and Engineering Departments, 348  
 University Colleges in Great Britain, Report of Committee on Grants to, 544  
 University Extension Movement, Lord Cranbrook and the, 155  
 University, the Function of a, Prof. W. E. Ayrton, F.R.S., 430  
 University Intelligence, 23, 45, 70, 92, 118, 139, 162, 286, 334, 356, 381, 428, 449, 549, 622.  
 University of London, W. T. Thielston Dyer, F.R.S., 392; Prof. E. Ray Lankester, F.R.S., 413; Prof. W. F. R. Weldon, F.R.S., 440  
 University, the Proposed Gresham, 323, 443, 517  
 University, Teaching, for London, Royal Commission to investigate the Question of a, 612  
 Upham (Warren), Fossils recently Discovered near Boston, 622  
 Uraninite, New Analyses of, W. F. Hillebrand, 119  
 Uranium in Swedish Anthracitic Minerals, Discovery of, Baron Nordenskiöld, 209  
 Urinary Secretion of Nitrogen, Dr. Gumlich on the, 599  
 Urine in some Infectious Maladies, Ptomaines extracted from, A. B. Griffiths, 72  
 Useless Studies, Value of, Prof. Geo. Fras. Fitzgerald, F.R.S., 392  
 Utilization of Homing Pigeons, W. B. Tegetmeier, 320
- Vaccination of the Dog, the Tubercular, Héricourt and Richet, 576  
 Vacher (M.), Workmen Killed and Wounded in Accidents in Germany, 350  
 Vacuum Discharge Streamers, on the Action of, upon each other, Dr. M. I. Pupin, 622  
 Vacuum Tubes and Electric Oscillations, Prof. Oliver J. Lodge, F.R.S., 366  
 Valence of a Coloured Radiation, Hering, 115  
 Value of Useless Studies, Prof. Geo. Fras. Fitzgerald, F.R.S., 392  
 Value, an Introduction to the Theory of, William Smart, 268  
 Varet (Raoul), Action of Metals on Salts Dissolved in Organic Liquids, 360  
 Variability of Nebulæ, Dr. Lewis Swift, 522  
 Variable Nebulæ, Some Apparently, Lewis Swift, 261  
 Variable Stars, Fuzziness of Some, Cuthbert G. Peek, 497  
 Variables, Two New, in Cepheus, Paul S. Yendall, 570  
 Variation of Latitude, Dr. S. C. Chandler, 404, 589; Robert B. Hayward, F.R.S., 465; Dr. B. A. Gould, 521; on the, M. Faye, 570  
 Vasey (Dr. George), Grasses of the South-West, 390  
 Vausseant (C. X.), Death and Obituary Notice of, 207  
*Vedalia cardinalis* successfully Colonized at the Cape of Good Hope, 615  
 Vedel (Lieut.), on the Polynesians, 615  
 Veeder (Dr. M. A.): Auroras at Lyons, N.Y., 7; Red Light after Sunset, 30; Plan for Observations to Determine Local Distribution and Altitude of, 234; Magnetic Storms, 557  
 Velocity, Molecular, Relation of Voltaic Electromotive Force to, Dr. G. Gore, F.R.S., 596  
 Venus, Rotation of, Herr Loschardt, 210  
 Verbeek (Dr. R. D. M.), Relics of the Hindu Period in Java, 88  
 Vereker (Hon. J. G. P.), the Resolution of Podura, 239  
 Verner (W.), Threatened Extinction of the Kentish Plover, 236  
 Vesuvius, Eruption of, 259  
 Vibrations, on Earth, Dr. Emil Oddone, 510  
 Victoria: Victoria Agricultural Department, Results of the Travelling Dairy, A. Crawford, 39; Hand-book of the Destructive Insects of Victoria, C. French, 246; Experimental Perfume Farming in, 305; Viticulture for Victoria, F. de Castella, 324  
 Vienna, Annales of the University Observatory in, 138  
 Vienna, a New Epidemic in, 349  
 Vilmorin (Philippe L. de), Les Fleurs à Paris; Culture et Commerce, 510  
 Vincent (M.), Thermometer-Temperature and Skin-Temperature, 304  
 Violle (J.), Radiation of Incandescent Bodies and Optical Measure of High Temperatures, 552  
 Virial Equation for Gases and Vapours, on the, Prof. P. G. Tait, 199  
 Virial of a System of Hard Colliding Bodies, on the, Lord Rayleigh, F.R.S., 80  
 Vision, Peculiar Eyes, James Shaw, 104  
 Viticulture: the Wines of the Medoc District, 279  
 Viticulture for Victoria, F. de Castella, 324  
 Vogel (Dr. E.), Praktisches Taschenbuch der Photographie, 51  
 Vogel (Prof. H. C.): Motion of Stars in the Line of Sight, 280; the New Star in Auriga, 498  
 Volcanoes: Projected Abandonment of Villages near Colima (Mexico), in Consequence of Activity of Neighbouring Volcano, 158; Volcanic Action in the British Isles, Sir Archibald Geikie, F.R.S., 398; Volcanic Action in Eastern Australia and Tasmania, T. W. E. David, 424; Eruption of Vesuvius, 259; Discovery of Saltpetre and Soda in Kilimanjaro District, 379  
 Voltaic Electromotive Force, Relation of, to Molecular Velocity, Dr. G. Gore, F.R.S., 596  
 Vonberg (Prof. Ignace), 518
- "W = Mg," Prof. Arthur G. Webster, 29  
 Waals's (Van der) Generalizations regarding "Corresponding" Temperatures, Pressures and Volumes, Prof. Sydney Young, 93  
 Waals's (Van der) Isothermal Equation, Prof. D. T. Korteweg on, 152, 277  
 Wagner (Rudolf von), Manual of Chemical Technology, 386  
 Walker (Alfred O.), Destruction of Immature Sea-fish, 176  
 Walker (G. T.), Repulsion and Rotation produced by Alternating Electric Currents, 213  
 Walker (J. J.), Ants' Nest Beetles, 351  
 Wallace (Dr. Alfred R.): Topical Selection and Mimicry, 30; the Naturalist in La Plata, W. H. Hudson, 553  
 Waller (Augustus D.), an Introduction to Human Physiology, Dr. E. H. Starling, 340  
 Ward (Prof. H. Marshall, F.R.S.): the Ginger-beer Plant, 190; The Oak, a Popular Introduction to Forest Botany, 509  
 Warner Observatory, 422  
 Warning Colours, Frank E. Beddard, 78; Edward B. Poulton, F.R.S., 174; W. L. Distant, 174  
 Washington Observations, 1886, 237  
 Washington Observations, 1887, 548  
 Washington Weather Bureau, Atlas issued by, 587  
 Washington, Wind-rush at, Prof. H. A. Hazen, 597



- Water, an Elementary Hand-book on Potable, Floyd Davis, Prof. Percy F. Frankland, F.R.S., 25
- Water, Air and, Vivian B. Lewes, 531
- Water Gas, Iron Carbonyl from, A. E. Tutton, 36
- Water Jets, Sensitive, W. B. Croft, 606
- Water-supply of London, John Hopkinson, 88; Appointment of Commission on, 470
- Watson (Rev. H. W., F.R.S.), on the Boltzmann-Maxwell Law of Partition of Kinetic Energy, 512
- Watson (Serenio), Obituary Notice of, 494
- Watson (W.), Effect of Fog on Plants Grown in the Houses at Kew, 16
- Wave-motion Model, F. Cheshire, 347
- Waves, Remarkable Illustration of Height of Breaking, 305
- Weather-cock, Self-Registering, J. Lawrence-Hamilton, 559
- Weaving as practised by the Navajo Indians, Dr. Shufeldt, 260
- Weber (Prof. Max), Freshwater Fauna of Sumatra, Java, &c., 408
- Webster (Prof. Arthur G.), "W = Mg," 29
- Weight, Examination of the Standards of Measure and, imured in the Houses of Parliament, 543
- Weinschenk (E.), Meteoric Iron, 69
- Weismannism, a Difficulty in, Edward B. Poulton, F.R.S., 52; Prof. Marcus Hartog, 102; A. H. Trow, 102, 175
- Weiss (F. E.), Caoutchouc-containing Cells of *Eucommia ulmoides*, 335
- Weldon (W. F. R.), the Renal Organs of certain Decapod Crustacea, 140
- Weldon (Prof. W. F. R., F.R.S.), the University of London, 440
- Wells (H. L.), a Series of Cæsium Trihalides, 310
- Wells and Penfield (Messrs.), Remarkable Series of Compounds of Halogen Salts of Cæsium with Two or more Atoms of Chlorine, Bromine, or Iodine, 325
- Werigo's (Dr.) Experiments respecting Influence of Oxygen on Elimination of Carbon Dioxide of Lungs, Prof. Zuntz, 576
- Wernsdorff (W.), the Sillimanite Group and the Part played by Aluminium in the Silicates, 141
- Wesendonck (Prof.), Gaseous Carbonic Acid not capable of Generating Electricity by Mechanical Friction on Metal, 306
- West India Islands, Zoology and Botany of the, 139
- West Indies, Dr. J. T. Rothrock on the Flora &c. of the Bahamas and Jamaica, 596
- Westgate-on-Sea, Aurora Visible from, 613
- Wethered (Edward), on the Microscopic Structure and Residues Insoluble in Hydrochloric Acid in the Devonian Limestone of South Devon, 597
- Weyl (Dr. Th.), Animals rendered Immune to Anthrax, 312
- Whale, a Steamer's Encounter with a, 88
- Whale, the Lesser Rorqual, Sir W. Turner, 454
- Wheat, Rust Fungus in, 615
- Wheat in Ohio, the Average Yield of, geologically considered, 420
- Whipple (G. M.), Magnetic Disturbance, 364
- Whitaker's Almanack for 1892, 156
- Whitcombe (Rev. R. H.), Elementary Trigonometry, 174
- White (W. H., F.R.S.), the Influence of Shallow Water upon the Trial Trip Speeds of Modern Vessels, 571
- White (William), Darwinian Theory, 53
- Whiteley (R. Lloyd), Chemical Calculations, 604
- Whitney (W. Dwight), the Century Dictionary, 316
- Whymper (Edward) : how to Use the Aneroid Barometer, 339; Travels among the Great Andes of the Equator, Prof. T. G. Bonney, F.R.S., 561
- Wiborgh's (Prof.) Air-Pyrometer, John Crum, 304
- Wild (H.), the Magnetic Storms of February 13-14, 1892, 480
- Wilkins (A.), Intelligence in Birds, 151
- Wilks (W.), the Place of Horticulture in Technical Education, 38
- Willéy (Arthur), a new Genus of Synascidians from Japan, 450
- Williams (Dr. C. Theodore), Value of Meteorological Instruments in Selection of Health Resorts, 551
- Williams (F. N.), the Genus *Dianthus*, 383
- Williams (Prof. G. H.) : a Geological Excursion in Maryland, 235; the part played in Growth of Geological Opinion by Regions near Great Universities, 519
- Williams (J. Francon) and William Hughes, the Advanced Class-Book of Modern Geography, 460
- Willis (J. C.), the Method of Fertilization in *Ixora*, 455
- Wilson (F. R. L.), Action of Dry Hydrochloric Acid Gas on Dry Carbonates, 503
- Wilson (Prof.), Experiment Illustrating Power of Palladium of Occluding Hydrogen, 380
- Winchester, Macro-Lepidoptera and Birds of, 115
- Wines of the Medice District, the, 279
- Wing in Dinornis, Evidence of a, Henry O. Forbes, 257
- Wind Direction, 149
- Wind-rush at Washington, Prof. H. A. Hazen, 594
- Winnicke's Comet, Dr. G. F. Haerdtl, 617
- Winnipeg, Lake, Geology of, J. B. Tyrell, 115
- Winter Storms of Northern India, Henry F. Blanford, F.R.S., 490
- Wislicenus (Herr Dr. Walter), on the Influence of Ring and Disk Blinds in Micrometric Measurements, 137
- Wissmann (Hermann von), My Second Journey through Equatorial Africa, 507
- Within an Hour of London Town, 557
- Woeikof (Dr. A.), Cold Waves, 357
- Wolf (Rodolf), Solar Activity in, 1891, 307
- Wolf's Periodic Comet, 42; Dr. Berberich, 237
- Wolf's Comet, 1891, 11; Herr Dr. Thraen, 548
- Wolf's Numbers for 1891, 307
- Wolstenholme (Prof. Joseph), Death of, 85
- Wood (Sir H. Trueman), Light, 269
- Woods, Furniture, D. Deeming, 459
- Woodward (Mr. A. S.), Appointed Assistant Keeper of Department of Geology at British Museum, 566
- Woodward (M. F.), the Milk Dentition of *Procyon (Hyrax) capensis*, 287; Teeth Development in the Marsupialia, 333
- Worship, Dwarfs and Dwarf, Harold Crichton-Browne, 269
- Worthington (A. M.), the Mechanical Stretching of Liquids, 358
- Wray (Leonard, Jun.), the Ipoh Poison of the Malay Peninsula, 278
- Wright (C. R. Alder, F.R.S.), on Certain Ternary Alloys, v., 381
- Wright (Prof. G. Frederick) : the Theory of an Interglacial Submergence in England, 310; Cirques, 317
- Wrightson (J.), Farm Crops, 247
- Yahgan, the, P. Hyades and J. Deniker, 577
- Yarrow (A. S.), on Balancing Marine Engines and the Vibration of Vessels, 571
- Year, the Origin of the, J. Norman Lockyer, F.R.S., 487
- Year-book of Science, 1891, Prof. T. G. Bonney, F.R.S., 604
- Yeast, Milk Ferment Identical with Kefyr, in use in Canada and United States, C. L. Mix, 471
- Yellow Butterflies, Pigment in, F. Gowland Hopkins, 197
- Yendall (Paul S.), Two New Variables in Cepheus, 570
- Yezo, the Fauna of, Dr. Adolf Fritz, 89
- Young (Prof. C. A.) : Note on the Chromosphere Spectrum, 28; the Chromosphere Line  $\lambda$  6676.9, 198
- Young (Prof. Sydney), Van der Waals's Generalizations regarding "Corresponding" Temperatures, Pressures, and Volumes, 93
- Youngusband (Capt.), Journeys in the Pamirs and Adjacent Countries, 353
- Zebra, on the Attitudes of the, during Sleep, and their Influence on the Protective Value of its Stripes, 248
- Zebra, Skin of Grevy's, brought from Somaliland, 598
- Zebraw, Notes on, S. B. Carhill, 526
- Zeitschrift für Anorganische Chemie, 421
- Zeitschrift für Pflanzenkrankheiten, 20
- Zimbabwe Ruins, Finds at the Great, Theodore Bent, 551
- Zodiacal Light, O. T. Sherman, 381
- Zoology : Zoological Gardens, Additions to, 21, 41, 67, 89, 116, 137, 159, 186, 210, 236, 260, 280, 307, 325, 351, 380, 404, 422, 445, 472, 497, 521, 547, 569, 589, 616; the Death of the Giraffe, 518; Zoological Society, 70, 164, 287, 383, 430, 503, 526, 597; Enormous American Lizard, L. Stejneger, 40; Herr Lehmann on the Camel, 87; Prof. Cossar Ewart on Scottish Zoology, 87; Zoological Regions, G. A. Boulenger, 104; Dr. Stirling's New Australian Animal (*Noloryctes typhlops*), J. D. Ogilby, 135; Squirrels in Winter, C. Fitzgerald, 137; Zoology and Botany of the West India Islands, 139; Text-book of Comparative

- Anatomy, Arnold Lang, 145; Lehrbuch der Vergleichenden Entwicklungsgeschichte der Wirbellosen Thiere, Dr. E. Korschelt und Dr. K. Heider, 145; the Migration of the Lemming, F. Howard Collins, 149; W. Dappa Crotch, 194, 294; Prof. George J. Romanes, F.R.S., 249; W. Mattieu-Williams, 294; Big Game in India, Harold Little-  
dale, 158; Discovery of New Species of Frog in New Jersey, Prof. E. D. Cope, 208; Animal Sketches, C. Lloyd Morgan, 291; Animals recently Extinct or Threatened with Extermination, F. A. Lucas, 305; Freshwater Springs in the Buffalo Bay and Niagara Region, Dr. Kellicott, 305; Zoology of the Sandwich Islands, Mr. R. C. L. Perkins Selected to Investigate the, 322; the Hydrocorallinæ Collected by Prof. Haddon in Torres Straits, S. J. Hickson, 407; Freshwater Fauna of Sumatra, Java, &c., Prof. Max Weber, 408; the Puma, P. W. True, 445; the Lesser Rorqual Whale, Sir W. Turner, 454; Zoological Record for 1890, 483; a Zoologist on Disease, Dr. Elie Metschnikoff, Prof. E. Ray Lankester, F.R.S., 505; Mr. Charles Hose's Collections, 517; Notes on Zebras, S. B. Carlill, 526; a New Oryx (*Oryx callotis*), 526; the New Imperial German Zoological Station at Heligoland, 544; Egg of the Extinct Gigantic Bird of Madagascar, *epyornis maximus*, 586
- Zune (M.), the Composition of Hæmocyanin, 456
- Zuntz (Prof.), Dr. Werigo's Experiments respecting Influence of Oxygen on Elimination of Carbon Dioxide by Lungs, 576



# NATURE

A WEEKLY ILLUSTRATED JOURNAL OF SCIENCE.

*"To the solid ground  
Of Nature trusts the mind which builds for aye."*—WORDSWORTH.

THURSDAY, NOVEMBER 5, 1891.

## ELECTRICITY AND MAGNETISM.

*Electricity and Magnetism.* Translated from the French of Amédée Guillemin. Revised and Edited by Silvanus P. Thompson, D.Sc., F.R.S. (London: Macmillan and Co., 1891.)

THIS work is an English translation of M. Amédée Guillemin's popular treatise of electricity. We are informed, in the preface, that the translation has been in great part executed by Mr. Colman C. Starling and Prof. Walmsley, under the editorship of Dr. Silvanus P. Thompson. It is a splendidly illustrated and beautifully got-up book, designed, so the editor says, rather for the table of the drawing-room than for the desk of the student.

We doubt whether, in fashionable drawing-rooms at any rate, scientific curiosity exists to any great extent; but now that large houses are very frequently lighted with electricity there may be a minority of people who are willing to spend any spare time left over from more absorbing drawing-room occupations in learning something of how the light is produced and of other applications of electricity. For such a public the present work seems exceedingly well adapted. It is popularly and attractively written, so far as a translation from a foreign tongue, supplemented, and to some extent corrected, by editorial paragraphs, can well be; it is profusely illustrated, and comprehensive to an extent which has made the book almost too bulky for convenient perusal.

Still, the remnant of people by whom popular scientific treatises such as this are welcomed, though numerous in itself, is, alas, only a very small minority of that great and influential section of the British public who are brought directly into contact every hour of their lives with the wonderful practical results of the progress of science. The great majority converse through telephones, consult their watches, and send telegrams, and know no more than a Hottentot does how a telephone acts, a watch goes, or a telegraph message is transmitted.

The book is divided into two parts, dealing respectively with phenomena and their laws, and practical applications; or, speaking briefly, theory and practice. In the theoretical part, magnetism is first treated, then electricity, in the order statical electricity, electro-chemistry, and electro-magnetism. In the practical part are comprised telegraphy and telephony, electric lighting and transmission of power, and a number of minor, but in themselves important, applications, such as clockwork-driving and regulation, electricity in warfare, and electroplating. Of the treatment of these subjects we can give here only the merest sketch, noting as we do so a few points in which the book seems to call for modification or improvement in a new edition.

The theoretical part begins with a brief account of the natural history of magnetism, then passes to a discussion of the polar theory of magnetism, starting with the notion of Thales that a magnet had a soul, and ending with the experiments of Coulomb and their results. An excellent description of Coulomb's torsion-balance experiments is given, and then follow the methods devised by Coulomb and Jamin for the determination of the distribution of magnetism in magnets. It is hardly correct to say, as is done on p. 33, that Coulomb's method "enabled him to study the distribution of magnetism in magnets; that is to say, how the magnetism at the surface varies along the magnet between one end and the other." Apart from the objection that the field at any point external to the surface of the bar depends really upon the whole distribution of magnetism, and not merely on that supposed to be near the point, and the further objection (which also does not seem to be stated here) that the vibrating needle itself affects the magnetization of the magnet, it is quite certain that this method, like others devised for the same purpose, cannot be made to give any definite information except as to the surface-distribution of magnetism, which, as Gauss showed, can be made to replace the magnet so far as the external field is concerned. By none of these methods can any information whatever be obtained as to the actual magnetization of a bar of finite cross-section.

It would have been well also if the editor had here appended a note as to the essential inaccuracy of Jamin's method "of placing on the point that we wish to study a

31297  
8/14/93

small contact-piece of soft iron, and of measuring by means of a graduated spring that gradually extended, the force requisite to detach the iron," and given a description of the much more satisfactory method adopted by Rowland and others.

After a chapter on methods of magnetization, in which all the ancient and now discarded methods of "touch" are described, we have an excellent popular discussion of terrestrial magnetism, ending with a splendidly illustrated account of aurora. The introduction of the subject of aurora at this point is justified on the ground that they are electrical phenomena connected with the magnetism of the earth, and a sketch is given of the various theories which have been proposed.

Passing now to the subject of electricity, we have the same wealth of illustration, though many of the smaller cuts, like some of those in the section on magnetism, are old familiar friends. Electrical machines are described, from Otto Guericke's down to Wimshurst's. Nothing impresses us as more indicative of the enormous advance of electrical science in recent times than a comparison of Plates V. and XIII. of this book. The former, a well-known picture, represents an electrical machine "according to the model in fashion about 1754"; the latter, a large Edison steam-dynamo. In the former a bevy of ladies and gentlemen in the costume of last century are grouped round a sulphur ball machine, which a gentleman in powdered wig and ruffles is vigorously turning by means of a crank attached to a large and much ornamented driving-wheel of wood. Evidently we have here "electricity in the drawing-room," as practised in the middle of last century. On the other plate we see a large modern steam-engine, in all its array of steam-pipes, balanced cranks, and connecting-rods, resting on a massive bed-plate of iron bolted to a base of masonry, and driving an enormous dynamo. The somewhat *dilettante* group of men and women have disappeared, and in their place stands a typical Yankee engineer, oil-can in hand, and coatless, intently regarding the bearings of the engine. Here there is no unnecessary ornamentation, no suggestion of elegant trifling, everything is sternly suggestive of work and nothing else. Nevertheless, in the contrast, the real dignity and beauty is with the present, not with the past; with modern science in the laboratory, the workshop, or the factory; with work carried on in the deepest earnest, with plain duty-doing, irrespective of sensation or applause.

Next comes an account of batteries, which (like several other parts of the book) we think might very well have been lightened by ignoring old and obsolete pieces of apparatus; after that, we have a discussion of the production of electric currents. In a book of this size, in which a considerable amount of space is devoted to things relatively unimportant, the subject of electrolysis might have been more fully treated; for example, there are matters connected with electrolytic theories to which, since such a theory as that of Clausius is introduced, a few pages might very well have been devoted. The absolute measurement of currents by means of electrolysis from the known electro-chemical equivalents of different substances is not referred to; indeed, an electro-chemical equivalent does not seem to be anywhere defined. But

what strikes one as strange indeed is that in the chapter on thermo-electricity Peltier's name is only mentioned in connection with an illustration showing what is called his "thermo-electric pince." Not a word is said on the subject of the Peltier effect, or the Thomson effect, not to speak of the bearing of these on thermo-electric theory! Again, no mention appears to be made of any form of secondary cell except that of Planté: surely some of the modern forms now so largely in use in practice for electric lighting, traction, &c., might have been figured and described.

The next section of theory, electro-magnetism, has three chapters devoted to it. The main phenomena are well described, and excellently illustrated by diagrams. Here the only forms of tangent and sine galvanometer figured are those of Pouillet (one of these (p. 337) has an enormous needle). Some of the splendid instruments which have been made for absolute measurements (for example, Fitzgerald's tangent galvanometer) ought surely to find a place in a work like the present, published as it is at a time when currents, &c., are no longer measured in arbitrary units, and their determinations are as far as possible divested of errors arising from instrumental peculiarities and accidents of place. A definition might also have been given here of the electro-magnetic unit of current, with some indication, where the constant of a galvanometer is referred to, of how it is possible to measure currents in absolute units, and the importance in this respect of electro-magnetic instruments, the constants of which can be determined from their dimensions and arrangement. At p. 333 a current of so many amperes is referred to as producing a certain force at the needle, but we have not anywhere, so far as we have been able to discover, a definition of an ampere.

The following passage (p. 369) apparently quoted from Faraday's "Researches," was at first sight rather startling: "In this state of circumstance(s) the force of the electro-magnet was developed by sending an electric current through its coils, and immediately the *image of the lamp-flame continued magnetic.*" It is almost needless to say that a reference to the "Researches" showed that the copyist had dropped out a line from Faraday's account of the actual phenomenon, which was not exactly that asserted in the quotation. After "flame" supply the words "became visible, and continued so as long as the arrangement."

The second part of the book is most excellent. All applications of electricity of any importance are fully described, and magnificent cuts, without stint, illustrate in the clearest manner the marvellous and complex contrivances and arrangements now in use in the various systems of telegraphy and telephony, electric lighting, &c., &c. Full-page plates of the illumination of Tunis by the search-lights of the French fleet, the electric light in use in the erection of a great Parisian *magasin*, the head-light of a locomotive illuminating the track, the interior of one of the Paris forts during the siege, and other subjects, serve to show the great part now played by electricity in all branches of industry and the arts, even including warfare, slow as that is in some respects to profit by the latest results of scientific invention. No book could form a more attractive and useful present for a boy with a taste for mechanics and practical electrical

science, and it is sure to be no less popular among older people who appreciate a sound and easy guide to the mysteries of practical electricity.

In taking leave of this work, we have only to say, what has already been indicated above, that an extension of the editorial remarks, and their absorption into the general current of the text, with consequent re-writing of some of the chapters, would render it more homogeneous, and throughout more in accordance with the electrical spirit of the age. Still, the clearness of its arrangement and style more than compensate for the disadvantages necessarily attending an edited English edition of a foreign scientific treatise, however popular. As a whole, it reflects credit on all concerned—translators, editor, and publishers alike. Its publication may even do something towards arousing an interest in electricity in circles, even in this proverbially practical country, where the light of science can hardly be said to have yet penetrated.

A. GRAY.

### BIOLOGY OF SEASIDE PLANTS.

*Die indo-malaysische Strandflora.* Von A. F. W. Schimper. Mit 7 Textfiguren, einer Karte, und 7 Tafeln. (Jena: Gustav Fischer, 1891.)

*Ueber die Mangrove-Vegetation im malayischen Archipel.* Von G. Karsten. *Bibliotheca Botanica*, Heft 22. (Cassel: Theodor Fischer, 1891.)

THESE two essays are exceedingly interesting contributions to our knowledge of plant-life on tropical sea-shores. They partly cover the same ground, partly supplement each other, and to some extent review and summarize the work of previous observers. Schimper treats of the salt-loving plants of the sea-shore generally, whilst Karsten's investigations are limited to the purely mangrove vegetation. Karsten also enters more fully into the formation of seeds—that is to say, into the development of the embryo-sac, the endosperm, and the embryo; and he follows up their germination and subsequent growth.

But the object of this notice is to give some general idea of the subject rather than a critical exposition of the writings of the authors named, for they are the first attempts at a connected description of the vegetation of tropical sea-shores.

The mangrove<sup>1</sup> vegetation—that is, the vegetation of the tidal forests—exhibits comparatively little variety, though the components belong to several different natural orders. First come the Rhizophoræ—genera *Rhizophora* (both in the Old World and in America), *Bruguiera*, *Ceriops*, and *Kandelia*; *Combretacæ*—*Lumnitzera* (*Laguncularia* in America); *Lythraceæ*—*Sonneratia*; *Meliacæ*—*Carapa*

(*Carapa guianensis*, a native of tropical America and west tropical Africa, does not appear to inhabit the tidal forests); *Myrsinacæ*—*Ægiceras*; *Rubiaceæ*—*Scyphiphora*; *Verbenacæ*—*Avicennia* (both in the Old World and in America); *Acanthaceæ*—*Acanthus ilicifolius*; *Palmæ*—*Nipa fruticans*.

The foregoing are the principal and widely-spread trees and shrubs of the mangrove girdle of muddy tropical shores; but this list might be largely augmented if we included those forming the tidal forests of the Bay of Bengal, and similar situations. Thus, in the Sunderbun, as Mr. C. B. Clarke informs me, the Sundra tree (*Heritiera Fomes*) abounds to such an extent that a railway is almost entirely devoted to carrying the wood to Calcutta, of which city it is the fire-wood. Among other common trees and shrubs are *Hibiscus tiliaceus*, *Sapindus Danura*, *Dalbergia monosperma*, *Derris uliginosa*, *Oxysterna esculenta*, *Dolichandrone Rheedii*, *Promnia integrifolia*, *Clerodendron inerme*, *Pandani*, *Phenix paludosa*, and *Cocos nucifera*. Mr. Clarke further informs me that the milk of the coco-nut in the Sunderbun is so salt as to be undrinkable. This is a very remarkable fact, and scarcely in harmony with the observations of Schimper, Karsten, and others, so far as mangrove plants are concerned generally.

In this connection it may be mentioned that mangrove plants have mostly very thick leaves, with few, very deeply seated stomata, so that transpiration is reduced to as low a minimum as in true xerophytes. As it is obvious that transpiration is not checked in halophytes because of a lack of water, it must be accounted for in some other way; and, as it has been found that the accumulation of salt in the tissues of the leaves beyond a certain quantity, varying in different plants, prevents the formation of starch and glucose, it is assumed that it is of a protective character; that, in short, smallness of transpiration means smallness of absorption, and thus no more salt is taken into the tissues of the plant than it is capable of assimilating. The correctness of this view is strongly supported by the fact that mangroves, grown in soil free, or practically free, from chloride of sodium, develop foliage of less substance, furnished with a larger number of stomata.

Turning to another phase in the life-history of mangroves—namely, reproduction—we find special provisions, suitable to the exceptional conditions, to insure the propagation of the species. Most of the members of the Rhizophoræ, for instance, are, in a sense, viviparous—that is to say, the seed germinates on the parent plant. Only one ovule is developed, the rest being aborted; and when the seed is ripe, the radicle, or primary root, grows through the apex of the fruit, assuming a slender club-shaped form, with the centre of gravity nearest the organic base, so that, when it eventually separates from the parent, it falls in such a manner that the radicle penetrates the mud, and usually sufficiently to withstand the ebb and flow of the water. The size and length of the viviparous radicle varies considerably in different genera, and even in different species, of the same genus, attaining its greatest development in *Rhizophora mucronata*, the foremost of the Asiatic mangroves, and perhaps the only one that sometimes grows where the soil is always submerged. In this the viviparous radicle is

<sup>1</sup> The word mangrove looks quite English, but it appears to be a corruption or modification of *mangro* or *mungro*, the name commonly applied, according to Rumpf (1750), and Blume (*Museum Botanicum*, i. p. 132), in Dutch Guiana to *Rhizophora Mangle*. However, it was employed in its present form by Dampier, Sloane, and other writers of the seventeenth century, and it is now applied to a number of different trees and shrubs that constitute the outermost fringe of vegetation on tropical coasts. It is also used to designate these shrubs and trees collectively. *Mangro-mangi* is the generic term in the Malay Islands for these trees and shrubs, and the different kinds are distinguished by affixes. In Brazil, *Rhizophora Mangle* is called *mangale* and *mangrus*; and in Panama, on the authority of Seemann ("Die Vulkanen der amerikanischen Pflanzen"), the former name is current, with various qualifying affixes. In Grisebach's list of colonial names of plants ("Flora of the British West Indian Islands," p. 785), we find mangroves (*Rhizophora mangle*); black mangrove (*Avicennia nitida*); white mangrove (*Laguncularia racemosa*); and Caragoa mangrove (*Conocarpus erectus*).

usually from twenty to twenty-four inches long, and occasionally as much as forty; and it is capable of growing even should it fall where it is wholly under water in the early stage of its further development. When the young plantlet is ready to separate from the parent, the aperture made by the growing radicle is sufficiently large to allow the inclosed or apical end to slip out, leaving the empty fruit still attached to the branch. And when this happens, there is a fully-formed leaf-bud at the top, from which the stem is developed. The primary root does not grow much after falling, but stout secondary roots are thrown out from this axis, successively, one above the other; and as they assume an arched form, and are produced in all directions, the plant becomes very firmly fixed. The American *Rhizophora Mangle* is very closely allied to the Asiatic and African *R. mucronata*; but whereas there is only one genus and one species of the order in the New World, there are several in the Old.

Singular to say, the only herbaceous plant of the Asiatic mangroves, *Acanthus ilicifolius*, is supported by similar stilt-roots. Most of the other trees and shrubs of the mangrove vegetation have horizontal roots, often of enormous length and strength, and some of them produce the so-called knee-roots in great abundance. These roots grow out of the ground, at an angle of about 45°, to a height of a foot or two, or perhaps more, and return to the ground at about the same angle, forming an anchor-like attachment. But their function is not merely to hold the plant. They are abundantly furnished with lenticels, through which the interchange of gases takes place—at least, such is the opinion of several eminent physiologists. Indeed, Karsten designates them breathing roots. Schimper figures negative geotropic roots of *Avicennia tomentosa*, which grow quite erect, from a thicker horizontal root, to a height of about a foot, and are either undivided or forked, and taper to a point. They are thickly studded with lenticels, as are the stilt-roots of *Rhizophora*. Another modification of root-production is exhibited by some of the mangrove-trees. Like *Rhizophora*, they produce aerial roots; but, instead of their remaining free, they eventually grow to the stem and outwards, forming plate-like buttresses.

Many other interesting facts might be extracted from the papers cited; but enough has been said to give an idea of the nature and value of their contents.

W. BOTTING HEMSLEY.

#### RICARDO'S "POLITICAL ECONOMY."

*Principles of Political Economy and Taxation.* By David Ricardo. Edited, with Introductory Essay, Notes, and Appendices, by E. C. K. Gonner, M.A., Lecturer on Economic Science, University College, Liverpool. (London: George Bell and Sons, 1891.)

THIS edition of Ricardo's "Principles" will be found useful to students of political economy. In addition to a large number of footnotes, the editor contributes an introductory essay of forty pages, and two short appendices—(1) on Ricardo and his critics, (2) on the effect upon rent of improvements in the fertility of land. The introductory essay gives a general account and brief critical estimate of Ricardo's work. It is characterized

by judicial moderation and impartiality; and many ambiguities and obscurities, due to the defects of Ricardo's style, are cleared away. Naturally, the abstract theory of value is treated first; and here the editor acknowledges that Ricardo did not attach sufficient importance to the influence of demand in determining value. But, on the serious question of the relation of capital to labour, he hardly seems to make Ricardo's position clear. He says (p. xxxix.) :—

"Of course, the mere fact that capital is subject to such replacements enables us to assert that, in the long run, there is a tendency to some equality of reward between indirect labour (*i.e.* labour embodied in capital) and direct labour. Thus in a somewhat abstract and general way we may renew our previous statement that commodities exchange in the ratio of their cost of production."

This passage, in which the editor concludes his general criticism of Ricardo's theory of cost of production, appears to involve the very fallacy that some Socialists have committed in their reasonings based on Ricardo. For it suggests their doctrine that capital is nothing but labour applied *indirectly* to production. Now Ricardo most explicitly avoided this fallacy. He wrote (p. 27) :—

"On account of the time which must elapse before one set of commodities can be brought to market, they will be valuable, not exactly in proportion to the quantity of labour bestowed on them, . . . but something more to compensate for the greater length of time which must elapse before the most valuable can be brought to market."

In short, Ricardo distinctly points out that an additional value arises when the same quantum of labour is extended over a larger period of time.

On the question of the distribution of reward between capital and labour, the editor remarks (p. xxxviii.) :—

"The two great agents in production—labour and capital—so divide total value between them that an increase in the value obtained by the one implies a diminution in the share of value falling to the other."

This apparently harmless truism is elaborated with painful prolixity. But the form in which Ricardo applied it was always "Profits depend on wages"—never "Wages depend on profits." With Ricardo, profits were the residue of production remaining over and above the value of the standard of comfort; and he did not enter too closely into the question of the forces determining variations in this standard. This crucial error shows itself throughout all Ricardo's reasonings—notably in his theory of taxation.

In Appendix B, the treatment of the effects upon rent of improvements in the fertility of land is very unsatisfactory. The editor says that Ricardo made two assumptions—one implicitly and the other explicitly. But if he had properly interpreted the assumption explicitly made, he would have seen that the other was unnecessary. Ricardo explains quite clearly that the contemplated improvement is assumed not to disturb "the difference between the productive powers of the successive portions of capital." The editor most gratuitously interprets *difference* to mean *ratio*, in the face of the fact that *all* Ricardo's illustrations assume constancy of difference, not constancy of ratio. Now Prof. Marshall has shown

that, with Ricardo's premiss, his conclusion is absolutely correct without any further assumption. If, on the other hand, we adopt constancy of *ratio* (instead of constancy of *difference*)—which was Mill's (not Ricardo's) supposition—then some further assumption must be made in order to demonstrate that improvement in fertility produces diminution of rent. In proving this point, the editor uses an unnecessarily complicated piece of mathematical reasoning.

Without further dwelling on these defects, it is only necessary to say that the explanatory footnotes are everywhere extremely helpful, and that the frequent references to Ricardo's "Letters to Malthus" will be found especially useful in further elucidating the great economist's doctrines. W. E. J.

### OUR BOOK SHELF.

*Photographic Pastimes: a Hand-book for Amateurs.*  
By Hermann Schnauss. Translated from the Second German Edition. (London: Iliffe and Son, 1891.)

MANY and varied are the effects that can be produced with the aid of the camera, and the present work gives a plain and popular account of the methods that have been adopted in producing them. The five chapters are headed, respectively—specialities, curiosities, photography by peculiar arrangements, photographic optical entertainments, and entertainments with photographic prints.

In carrying out the experiments contained under the first two headings, amateurs will find their time fully occupied, while the novel effects that can be obtained will afford both instruction and amusement. With reference to taking pictures by moonlight, we can quite agree with the author when he says that "if the moon is included in the picture, its track will make a straight band of light nearly half-way across the photograph, which, besides the peculiar illumination of the landscape, gives a most characteristic effect." The characteristic effect, we should think, would be very decided.

An excellent and easy method of producing ghosts, which may prove useful to amateurs, and which is not wholly described in this book, is as follows:—The ghost consists of a person completely covered over with a sheet, the latter being so adjusted as to give a dim outline of the head; when in position, a short exposure of about half an inch of magnesium is given: then, as soon afterwards as possible, without moving anything with the exception of the ghost (which now is no longer required), another exposure is made, by means of a magnesium flash light, of the other figures that are required for the picture. In this manner excellent results have been obtained, the pattern on the wall appearing through the ghost, giving it quite a realistic appearance.

In these and the remaining chapters, descriptions of many novelties too numerous to mention are given, of which the following may serve as types—caricature, composite, and pin-hole photographs, statuary portraits, kaleidoscopic and stroboscopic pictures, &c.

Altogether, amateurs will find in this hand-book much that will occupy them during the winter months, when out-door photography is more or less at a standstill.

*On Surrey Hills.* By a "Son of the Marshes." (Edinburgh and London: W. Blackwood and Sons, 1891.)

THE Surrey hills are so well known that an ordinary writer would find it hard to say anything fresh about them. The "Son of the Marshes," however, has an exceptionally good power of observation, and even familiar facts he is able to present in a way that seems to give them new

vitality. In all his books he is especially interesting in passages dealing with the habits of animals, and there are many such passages in the present volume. No secondhand information is offered; the author tells us only of things which he himself has had opportunities of noting. Most of the chapters have already appeared in *Blackwood's Magazine*, but many who read them there will be glad to possess them in their present form. The manuscripts of the "Son of the Marshes" have, as usual, been edited by Mr. J. A. Owen, who does not say precisely how much his editorial work includes.

*Heroes of the Telegraph* By J. Munro. (London: Religious Tract Society, 1891.)

THE author of this book desires that it shall be regarded as in some respects a sequel to his volume on "Pioneers of Electricity." He begins with a short account of the origin of the telegraph, and then sketches the lives and principal achievements of those discoverers and inventors to whom we owe the electric telegraph and the telephone—Charles Wheatstone, Samuel Morse, Sir William Thomson, Sir William Siemens, Fleeming Jenkin, J. P. Reis, Graham Bell, Thomas Alva Edison, and D. E. Hughes. In an appendix, Mr. Munro gives brief accounts of various other investigators whose names are intimately connected with his subject. He has a plain, straightforward style, and the book will give much pleasure to young readers who take interest in the practical applications of science.

### LETTERS TO THE EDITOR.

(The Editor does not hold himself responsible for opinions expressed by his correspondents. Neither can he undertake to return, or to correspond with the writers of, rejected manuscripts intended for this or any other part of NATURE. No notice is taken of anonymous communications.)

#### The Koh-i-Nur.

DR. BALL, in his reply (*NATURE*, vol. xlv. p. 592) to my criticisms on his "true history" of the Koh-i-Nur, feels aggrieved that I "smite him in season and out of season," and considers me in the light of a partisan for doing so. I can assure him that my criticisms were absolutely impersonal, as I have never, to my knowledge, seen him in my life, and bear no kind of ill-natured feeling towards him; indeed, I said whatever I was able honestly to do in favour of his work. But of course, where I considered his arguments to be groundless or illogical, I met them. If he has read into my remarks an asperity I did not desire to impart to them, surely he should blame himself somewhat for the style of his attacks on those who went before him, and of whom I have shown that they knew not less, but more, of the subject than he did himself.

I have pleasure in withdrawing my expression of an accusation that Prof. H. H. Wilson was one of those against whom Dr. Ball threw out a sneer in relation to the earlier history and traditions attaching to the Koh-i-Nur. I supposed that, as he has laboured to make his knowledge of the authorities on the subject complete, he would certainly have known what was of common knowledge at the time as to the authorship of by far the most interesting notice ever penned on the Koh-i-Nur. But that was long ago. It was that notice, however, that brought me into such contact as I have had with the subject. As a young Professor at Oxford, I had the honour of knowing the great master of Sanskrit and of Indian lore; and as I had been interested in Indian history I ventured to approach him now some thirty-five or thirty-six years ago on the subject of the values assigned by him to certain weights referred to in his article. I drew his attention to Babar's valuation of the mishkal in ratis, and I further pointed out the probability of the retention by Shah Jahan of the Mogul diamond in his captivity. He received my suggestions in the kindest spirit, and offered me every help in further inquiry; and at the East India Company's Library he placed all the documents before me.

I shall not weary your readers with thrashing out and again winnowing the various statements involved in this controversy.

I could say more about the Garcias-De Boot matter, but I am satisfied with having shown that it was not Dr. Ball, but Mr. King, who, twenty-five years ago, explained the misprints in De Boot, and declared the very great improbability of the 140 mangelin diamond of Garcias, estimated by De Boot at a weight of 187½ carats, not being the Koh-i-Nur. Dr. Ball alludes to inaccurate figures in Mr. King's treatise. That Mr. King was inaccurate, was hasty, no one knows better than I. Nor did any of his many warm friends lament more than I did the unhappy infliction of advancing blindness which explains so much of the former's demerit, as no one admired more than I the boy-like enthusiasm which often gilded in his imagination what seemed to others metal of a less precious order than gold. He had a splendid memory, and he trusted too much to it in drawing out from it, rather than throwing on his impaired eyesight, the verifying the records of his enormous reading and varied knowledge. I had controversies with him over a thousand subjects, but while he kept singularly isolated, and let no one come between him and his printer, he never resented a friend's criticism or difference from him.

As regards the scene before the throne of Aurungzebe, it can never, perhaps, be determined whether the view first put forward by Prof. H. H. Wilson, that Tavernier weighed the diamond, but with weights and scales supplied by Akil Khan its custodian, is the correct one; or the view I have held—namely, that Tavernier's account of the transaction given in his tenth chapter was barely compatible with his having weighed the stone, as he asserts he did in the twenty-second chapter of his book, which was avowedly a retrospective one written long afterwards, and near the end of his life. That I have reason for adhering by preference to the latter view is confirmed by what Dr. Ball himself says of another passage referring to the Great Mogul diamond. Dr. Ball condemns the passage as "in part spurious if not altogether so, . . . as the statements are in contradiction with others made elsewhere in the 'Travels'; and there is the strongest reason for attributing them to an erroneous editorial interpretation, and not to Tavernier himself." The delinquent he supposes to have been a M. Samuel Chappuzeau, the reputed editor of Tavernier's works.

As a fact, the travelled Frenchman seems to have been a person somewhat illiterate, as he had to call in extraneous aid in putting his memoirs into shape. He must be supposed to have picked up some colloquial Persian, but otherwise seems to have been dependent on interpreters throughout his travels. The treatment Chappuzeau received during a year of editorial service at the hands of Tavernier and his wife is recounted by Dr. Ball as a sort of "mutilation, if not martyrdom." Chappuzeau appears to have described the notes of the traveller, on which he had to depend, as a chaos, and to have attributed the only written part of them to the permanship of one Father Gabriel. I think I am justified, then, in asking whether the account of the weighing in the later chapter may not have been an editorial afterthought; but whether it were so or was historical, in the sense assigned to it by Prof. Wilson, really very little affects the question.

The logical issue of this discussion is involved in the acceptance of one of two alternatives, the one a series of astounding coincidences and improbabilities, the other one of simple probabilities. Garcias saw a diamond weighing 140 mangelins; Le Cluze estimated its weight at 700 apothecary grains (= 573·8 grains troy, or 180 carats). De Boot assigned to it a weight of 187½ carats. The Koh-i-Nur weighed 589½ grains, or 186 carats. Misinterpreting a note of Le Cluze, Dr. Ball throws scorn on this having anything to do with the Koh-i-Nur.

Tavernier sees a diamond to which a weight is assigned of 319·5 ratis. Babar's diamond (the Koh-i-Nur) weighed 8 miskhals, or 320 ratis, equivalent to about 186 carats. Dr. Ball says this diamond was that known as the Great Mogul, that it is the Queen's Koh-i-Nur, but that it was whittled down by necessitous princes—to find them, in fact, in pocket-money—from 280 carats to 589½ grains, or 186 carats, the identical weight of Babar's diamond and of the Koh-i-Nur. Dr. Ball finally declares the Darya-i Nur to have this same weight of 186 carats.

In opposition to this impossible recurrence of coincidences I have endeavoured to show that the stone Garcias saw may have been the Koh-i-Nur, that the one Tavernier handled was in all probability—I believe was certainly—the Koh-i-Nur. I say there is no evidence whatever of the Koh-i-Nur having been whittled down by cleavage, accidental or intentional; that its form in 1851

was more probably its original form rudely faceted (and I think, perhaps, I may not be without a mineralogist's experience when I say this); I further say that the Darya-i-Nur is undoubtedly the "Golconda table" diamond.

Finally, I assert the probability that the Great Mogul, unwhittled down and entire, is in the jewel chamber of the Shah of Persia to this day.

Of the great diamond which I would identify with this stone I append a tracing, in which it is seen in its carcanet of ruby-enamel. In the original drawing it is accompanied to right and left by two large diamonds, similarly girdled; while, above and below, is a row of three enormous rubies encircled by emerald-enamel. Ten pearls above and ten below, some of them ¼ of an inch in diameter, form a fringe to this gorgeous ornament. It

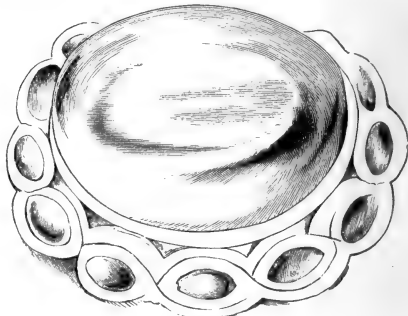

FIG. 1.—Great Mogul.

is, however, only one half of a cylindrical cap the corresponding half of which is its counterpart in splendour and wealth of stones, only the Darya-i-Nur is in, that other half, the central ornament.

I leave the great stone to speak for itself in the tracing, and I furthermore for comparison give a tracing from a drawing of the Koh-i-Nur, taken from a somewhat similar point of view—that is to say, looking down on it.

That the Koh-i-Nur was valued beyond these greater stones I believe to have been in consequence of its being the reputed talisman of Indian empire. It was probably that last relic of his treasure surrendered by the miserable Muhammad Shah when he exchanged caps with Nadir, and the conqueror saluted this most historic of his spoils by the name it has since borne—

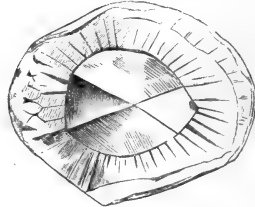

FIG. 2.—Koh-i-Nur.

the Koh-i-Nur. It was certainly the diamond that Shah Rukh, after yielding up all his wealth of jewellery, held to through every torture till he gave it to Ahmad Shah. Shah Zaman carried it to his prison, and secreted it in a crevice; whence Shah Shuja recovered it on information from his blinded brother.

Shah Shuja again clung to the old talisman not less fiercely than those who had preceded him, till he surrendered it to Runjit Singh under pressure which amounted to compulsion; and memorable was the answer of Shah Shuja to Faker Nur-ud-din, who had been sent by Runjit to ask in what its value consisted. It is "good luck," said Shah Shuja, "for he who has possessed it has done so by overpowering his enemies."

I have put, I hope clearly, to my readers, the alternative and



conflicting interpretations of the portion of the accounts of the Koh-i-nur from Babar's time onward. There are still some interesting questions of a difficult kind regarding its history antecedent to the days of the Mogul Empire. But I believe I have said now my last word regarding the later history, and leave to my readers the decision as to the side in this little controversy on which the truth is more likely to lie.

N. STORY MASKELYNE.

Basset Down House, October 26.

#### A Rare Phenomenon.

AURORAS were visible at Lyons, New York, on September 9, 10, and 11. That on September 9 was very fine, flickering streamers and arches forming at intervals from 8 o'clock to 10 o'clock p.m. A peculiar feature of this aurora was an arch similar to that described in NATURE of September 17 (vol. xlv, p. 475), as having been seen by Mr. Tuckwell at Loughrigg, Ambleside, on September 11. The arch seen at Lyons on September 9 was visible shortly after sunset, and remained in the same position throughout the evening. It consisted of a narrow band of light, which arose vertically from a point on the horizon nearly due west, and passed through the constellations of the Northern Crown and the Lyre, and just south of the zenith down to the eastern horizon. When it was brightest, at about 10 p.m., a few small streamers formed in connection with it nearly in the zenith; otherwise it consisted simply of a narrow band of white light separated by a wide interval from the auroral osculations and streamers in the northern heavens. This seems to have been very similar to the band seen by Mr. Tuckwell. Other instances have been noted by the writer in which some peculiarity of form or colour characteristic of an outbreak of the aurora has attended its appearance in localities remote from each other.

M. A. VEEDER.

Lyons, N. Y., October 17.

Two instances of the occurrence of the rare phenomenon referred to in your issue of September 24 (vol. xlv, p. 494), by Prof. R. Copeland and Mr. W. E. Wilson, will be found recorded in the Transactions of the Nova Scotian Institute of Natural Science, vol. vi, p. 100. The dates of these occurrences were July 31 and September 5, 1883. The general appearance and position of the luminous arch were the same in both cases as in those described by Prof. Copeland and Mr. Wilson. Two additional points were noted, however, which are worthy of mention, viz. (1) that the arch of September 5 had a slightly marked rayed structure, which, when first observed, was in the direction of its length, but which gradually changed to a direction inclined about 45° to the longitudinal, and (2) that the spectrum of this arch, as determined by one of Hilger's pocket spectroscopes, consisted of two lines in the green, one quite bright and the other faint.

On Tuesday, September 1 of this year, I again observed the same phenomenon at Halifax, N.S. I was unable to make accurate observations, but noted the following facts:—The luminous arch was quite bright when first observed, at 11.30 p.m., and extended from horizon to horizon. Fifteen minutes later it had completely faded away. It was about 4' or 5' in width throughout its whole length. It met the horizon at points about 10° or 15° to the north of the east and west points, and passed through a point a few degrees south of the zenith. When first observed, it was approximately uniformly bright throughout, except at the edges, where its brightness diminished rapidly outwards. To the eye its light seemed to be white, and stars were visible through it. In fading away, the east and west ends disappeared first, and the main body of the arch became gradually fainter, wider, and more variable in width. The night was bright and clear, and the temperature lower than it usually is in the beginning of September, and there was no appearance of aurora in other parts of the sky.

Except on this occasion I have neither observed this phenomenon nor heard of its occurrence since 1883. But as it might readily occur without my either seeing it or hearing of it, I cannot say that I know it to be rare.

J. G. MACGREGOR.

Dalhousie College, Halifax, N.S., October 14.

It has twice been my good fortune to observe phenomena similar to that described in NATURE of September 24 (vol. xlv, p. 494). My recollections of the first occasion are some-

what indistinct, but at all events the luminous band extended east and west almost through the zenith, and was preceded by an auroral display. It occurred in August or September of 1883 or 1884.

My attention was again directed to a similar appearance on the evening of September 9 of the present year, while near Toronto. The narrow band of light, as before, extended from the eastern almost to the western horizon, passing through the zenith, and was accompanied by an aurora.

It is worthy of note that I saw the phenomenon at Toronto on the evening of September 9, not September 11.

R. N. HUDSPETH.

Bishop's College, Lennoxville, P. Q.

#### Apparent Size of Objects near the Horizon.

SOME years ago there appeared an account of an investigation into the cause of the sun and moon looking larger when low down than when high up in the sky. The theory advanced as the result of the investigation attributed the effect to a physiological cause. One could not expect an explanation of this kind to be applicable to all individuals, but rather that with different persons there would be different results; so I have made observations—81 in number—to find out what law applies to my own case. These observations were made by taking notice of two stars near the horizon, and then looking up near the zenith to see what stars in that situation appeared to be the same distance apart as those near the horizon. I took a great variety of different cases, the length of the compared arcs varying from 1° 4' to 100°. I observed them also in various angles of position, from horizontal to vertical; and sometimes had the two arcs at the same angle of position upon the retina, and at other times at different angles.

The result of this investigation is an unexpected one, showing that the length of the observed arc greatly affects the result of the estimation—short arcs appearing longer when near the horizon than when high up, and long ones appearing shorter.

The comparisons were made in either of two ways; according to one method, after I had carefully taken note of the apparent length of the arc near the horizon, and had fixed an idea of it in my mind, I then took a single glance at the stars near the zenith and fixed in a moment upon an arc that appeared to be of the same length; whereas in the other plan I made as deliberate and careful an estimation of the arc near the zenith as of that near the horizon with which it was compared, looking to and fro from one to the other till I was satisfied as to their apparent equality.

One would naturally expect that the instantaneous estimations would be less accurate than the careful ones, and this is found to be the case. Taking all the observations, I find the average deviation from the truth of a single estimation is 7.7 per cent. in the case of careful comparisons, and 10.3 per cent. in the case of the instantaneous ones. The following formula is based upon the careful comparisons—

$$L = l \left\{ 1 + \frac{A^{\circ} - a^{\circ}}{74^{\circ}} (.085 - .0032l) \right\},$$

where  $l$  and  $L$  are the lengths (in degrees) of apparently equal arcs at  $a^{\circ}$ , the lower altitude, and at  $A^{\circ}$ , the higher altitude, respectively. According to this formula, an arc 26° 48' long appears the same length at whatever altitude it is situated, but an arc shorter than 26° 48' appears longer at the horizon than at the zenith, and an arc in excess of 26° 48' would actually appear longer near the zenith than near the horizon: an arc 1° 4' long (the shortest in my observations), when at the horizon, would appear equal to an arc in the zenith 109.85 per cent. of its length; while an arc 100° (about the longest in my observations) at the horizon would appear equal to an arc of 71° 30' only in the zenith (*i.e.* with its middle point in the zenith). When the above formula is applied to all the observations, the average deviation (of the observed lengths from the computed) is reduced to 4.2 per cent. in the case of the careful comparisons, and 7.0 per cent. in the case of the instantaneous ones. If this formula can rightly be applied to objects of such small dimensions as the sun and moon, it (as will be seen) allows only a small increase for their apparent size near the horizon upon that when they are seen at a considerable altitude.

It would be easy to find a more complex formula which would satisfy the observations still better, but these are not sufficiently numerous to warrant the doing so.

It might be supposed that the estimations would agree better when the angles of position are the same for both arcs compared together, than when they are different. But this supposition is not borne out by my observations; for after correcting them by the above formula, the average deviation from the truth in the case of the careful comparisons is 4.4 per cent. when the angle of position of both arcs on the retina is the same, or within  $10^\circ$  of the same; and 4.1 per cent. when it differs more than  $10^\circ$ ; while in the case of the instantaneous comparisons these numbers are 7.9 and 6.3 respectively.

When the lower arc is horizontal, or nearly so, it is (on the average) estimated as being shorter than when in a vertical position, but the difference is so slight that it is doubtful whether it would not disappear with a larger number of observations. The best correction formula I have obtained for this is to apply the factor

$$(1.04 - .048 \cos d)$$

to the result already obtained:  $d$  being the deviation of the lower arc from the horizontal. But the application of this factor only reduces the sum of the squares of the differences between calculation and observation in the case of the careful comparisons from 1163 to 1111.

The angle of position of the upper arc seems to make no difference in the results. T. W. BACKHOUSE.

West Hendon House, Sunderland, October 24.

#### Proper Motions of the Stars.

MISS CLERKE, in her very interesting article (NATURE, vol. xlv. p. 572) on the motion of the sun in space, seems to think that we have only the two alternatives of supposing that the brightness of a star is independent of its distance, or that the motions of the stars increase with their distance. I suspect that, when the proper motions of all stars down to the 9th magnitude have been tabulated, the necessity of adopting either alternative will disappear. My object in writing this letter, however, is to call the attention of spectroscopists to the question thus raised. The spectroscope, when used in connection with a powerful telescope, ought to be able to show whether the fainter stars as a rule move more rapidly in the line of sight than the brighter ones; for if the average motion in the line of sight is the same in both cases, astronomers will be slow to accept an explanation of phenomena which supposes a different average velocity on the whole. But even instruments incapable of deciding this question may throw light on the subject. It now appears certain that if a Sirian and a solar star of the same mass were placed at the same distance from us, the Sirian star would appear more than one magnitude brighter. Hence, before we can use magnitudes as in any sense a test of distance, we must ascertain the relative proportion of Sirian and solar stars in the groups which we are comparing. It would also be very desirable that the magnitudes of the stars employed by Profs. Eastman, Boss, and Stumpe, should be photometrically determined. The photometer has at all events the advantage over the eye that its results are in all cases (allowing for errors of observation) comparable. W. H. S. MONCK.

Dublin, October 17.

#### California Foxes.

IN NATURE of September 10 (p. 452), there is a paragraph in praise of the intelligence of the (English) fox, with examples in proof. Permit me to say that his California cousin is next door to a fool. My young son has amused himself for the past three summers in trapping (in large box-traps) the small California foxes which infest these mountains, and which live on a mixed diet of Manzanita berries and astronomer's chickens. I pass over the fact that each trap has painted over its door "Danger to all who enter here!"; and I proceed to show that our California foxes are barely one remove from idiots. When they are caught, my boy is in the habit of fastening a small leather collar about their necks, and of chaining them with light chains to stakes near the Observatory buildings. Many of them have escaped by parting the chains (by dint of strength, not of intelligence), and have been again caught within two or three days in the same traps! One of them was caught three times in quick succession! I presume an English fox, once caught, would emigrate to North Britain, or at least to the next county. My own ideas of the intelligence of the fox, until I came here, were derived from Goldsmith's "Animated Nature," and, generally, from English writings.

I have now become satisfied that the California fox is *arriéré*. Either the struggle for existence is not sharp here, or he has made up his mind that existence is not worth struggling for.

Lick Observatory, October 8. EDWARD S. HOLDEN.

#### A Plague of Small Frogs.

MY wine-cellar has been visited during the recent rains with a curious plague of small frogs (*Rana temporaria*) all the same size, about one-inch long. There would be nothing surprising in this visitation were it not for the apparent absence of any means of communication from outside, the level of which is six feet above that of the cellar; there is no drain near that part of the house. There is a step up before you go down into the wine-cellar from the adjacent cellar, against which the door closes, leaving no crack any animal so large could squeeze through. The cellar has solid stone walls and a bricked floor. During the recent floods the water stood some three or four inches deep there, apparently oozing through a tiny hole level with the floor on the outside wall, into which the point of a pencil could only penetrate for an inch. Even had it been possible for these little creatures to come in that way they must have burrowed down six feet from the outside level. Only one or two were found in the cellar adjacent, which is lighted by a grating into the garden, whereas in the wine-cellar two or three dozen were caught, many of them drowned by the flood.

Is it not unusual for bats to fly in the day-time? Here one has been doing so for two afternoons, coming out about 2.30, and flying backwards and forwards after insects in most brilliant sunshine. The gardener tells me he has never observed them do so before; and having sometimes caught them in the day-time, always noticed that when thrown into the air they would drop at once, and run instead of flying.

R. HAIG THOMAS.

#### BOTANY OF THE EMIN RELIEF EXPEDITION.

THE botanical exploration of Tropical Africa leaves so much to desire that it was somewhat disappointing to find that Mr. Stanley brought nothing back which would give any idea of the nature of the dense forests which he traversed. The conditions under which such an expedition is necessarily executed make natural-history-collecting extremely difficult. Travellers, however, often suppose that because they cannot make extensive collections they can do nothing to add to our knowledge. Yet to fill a small portfolio with well-selected and significant specimens is not a very difficult matter. And these may often furnish the basis of useful and important conclusions as to the general nature of the flora. Sir Joseph Hooker was able to give the first account of the vegetation of Kilimanjaro from a small parcel of plants collected by a missionary, the Rev. Mr. New, who was supplied for the purpose by Sir John Kirk, with "a bundle of old *Guardians*." An officer of the Ashanti Expedition brought from Comassi the fruit of what proved to be a new species of *Duboscia*. And quite lately Lord Lamington sent to Kew a small parcel of plants collected by himself in an expedition through the Shan States, which contained good specimens of an interesting plant only known previously from imperfect material collected by Griffith. It has now been worked out and figured in the Kew "*Icones Plantarum*."

Nor is it so difficult as it might be supposed to do even more than this. And I am not sure that a little careful and intelligent plant-collecting would not be a healthy and useful distraction to the tedium and strain of an arduous journey. Nothing could probably exceed the difficulties under which Joseph Thomson travelled in Masailand; yet he managed, notwithstanding, to get together a tolerably extensive and most valuable botanical collection. Upon this Sir Joseph Hooker was able to base the first attempt at a rational theory of the geographical relations of the high-level flora of Eastern

Equatorial Africa. Nothing, again, could be more admirable than the collections made by Brigade-Surgeon Aitchison when attached to the Kuram Field Force under Sir Frederick Roberts in Afghanistan. And the Government of India has now arranged—and it is an indication of the sympathy for science which animates its members—that, as part of the organization of the Botanical Survey of India, a botanist shall for the future be attached to all frontier expeditions.

Major Jephson, who accompanied Mr. Stanley, seems, however, to have had his eyes about him. A correspondent has sent me a copy of the October number of the *Mayflower*, a small monthly horticultural periodical published in New York, which contains (pp. 155, 156) a short paper by him on the "Plants of the Dark African Wilderness." This seems to me worth putting on record in the pages of NATURE, where it will be at least more accessible for future reference. At my request, Mr. Baker, the Keeper of the Kew Herbarium, has had the paper annotated with such critical comments as were possible.

To Major Jephson's paper Mr. Stanley has prefixed a brief introduction, which adds nothing of importance. He remarks:—

"In this branch of science I fancy we were all but amateurs, and considering what very little time any of us could devote from the engrossing business of marching, and seeking for food to sustain life, Mr. Jephson shows what might have been done by him had circumstances been more favourable."

This is, however, erring a little on the side of modesty. As I have already shown, amateurs can do very useful work without much difficulty, if they are content to do only a little, but to do that little carefully. Some further observations are open to more serious criticism:—

"Africa is yet too young and too crude for the scientific botanist. We have only been pioneers to stake the highway to make ready for those who shall come after us. When the rails have been laid in pairs of iron lines across the swamp and desert, and the engine boat cleaves the red bosoms of the great rivers, and furrows the dead green face of the fresh-water seas, then the tender-nurtured botanist, conveyed from point to point without danger to his valuable life, may be trusted, with his enthusiasm and devotion, to bring to us results worthy of science and the age. Of those who have given us an insight into the botanic treasures of the African world, Schivernuth (*sic*) is by far the best, but he has also laboured under such disadvantages and discomforts that he was not able to do for Equatorial Africa a tenth part of what Bates did for the Amazon."

One cannot but wonder a little at the ignorance of the literature of African travel which this paragraph displays. Men like Grant, Speke, Kirk, Welwitsch, Mann, Vogel, Barter, and Thomson, to mention only a few of those to whom we owe our knowledge of the African flora, would have thought it comical to be described as "tender-nurtured" botanists. The work of Schweinfurth was admirable; yet no one would, I think, be more surprised than that distinguished naturalist, Mr. Bates, to learn that the botanical collections which he never even professed to make, were ten times better.

W. T. THISELTON-DYER.

Royal Gardens, Kew.

"It is difficult to give an accurate idea of the flowers we saw in our march through Africa in a short magazine article, but I here give a short sketch, mentioning some few things which I think may be interesting to my readers."

"The great forest of Central Africa through which we passed is not so rich in variety of flowers and orchids as the forests of Mexico and Brazil, or even the jungles of India and Ceylon. It is chiefly rich in flowering vines,

trees, lilies,<sup>1</sup> and Begonias. There is, however, a great wealth of different kinds of ferns, such as I have often seen cultivated in hot-houses in England. In many places the damp ground was covered by a thick growth of filmy ferns and Lycopodium of the most beautiful description.

"Here is a short extract from my journal, which will give some idea of the every-day sights we saw on the banks of the Lower Congo, 1700 feet above the sea, and 250 miles distant from it:—

"At the bottom of a piece of swampy ground I came to a small stream, on the banks of which were growing *Osmunda regalis*,<sup>2</sup> or Royal fern. It was slightly stunted in growth, being not more than 2 feet in height. It is the first I ever have yet seen in the tropics. Close by the stream was growing a group of beautiful ground orchids,<sup>3</sup> in form like a *Hyacinthus candicans*. There were clusters of great pink flowers with yellow centres; the whole had a very gorgeous effect. Here, also, was a profusion of Lycopodium.<sup>4</sup> It is of a kind I have not yet seen; it creeps up and over everything in great blue-green masses; its long tendrils creep up the tree trunks like ivy, to a height, in some cases, of 4 feet. There were quantities, also, of the ribbon fern, exactly like the *Davallia pentaphylla*,<sup>5</sup> which has been introduced into English hot-houses from the Malayan Archipelago. What would not florists at home have given for an acre of this ground?"

"In the forest there were two kinds of lilies which were common. One, which grew in swampy ground, was in form like an *Amaryllis*.<sup>6</sup> It was white, with a deep crimson centre, and had a delicious but heavy scent. The other was a lily,<sup>7</sup> which grew everywhere through the whole length of the forest. It was of a brilliant scarlet colour, and was formed of several hundreds of small flowers, forming a round ball like a huge Guelder rose, four inches in diameter. It was of such a brilliant scarlet that it looked almost metallic, growing in the darkest recesses of the forest. One of the commonest and most striking of all the ferns we saw was the *Platyserium alcornice*.<sup>8</sup> It is an extremely interesting fern, one of a singular genus of epiphytal plants, growing on the branches of trees. Our Zanzibaris called it 'elephant ear,' from its curious shape. There was another of the same family, *Platyserium Stemmaria*, which we found growing upon rocks in the open country. Both these ferns grew at altitudes from 1000 to 5000 feet. Tree-ferns<sup>9</sup> of the ordinary kind we found growing in all the gullies and streams on the slopes of the mountains above the Albert Nyanza. The altitude was from 5000 to 6000 feet above the level of the sea, and I noticed especially that the flora here was remarkably like that in the Central Province of Ceylon, which is an altitude of 2500 to 4000 feet above the sea.

"By far the most common plant which we saw in the jungle was the *Amonum*, or wild cardamom.<sup>10</sup> It was almost precisely the same in form as the cardamom which is cultivated in Ceylon. It grew almost throughout the whole of Central Africa. It has a large purple flower, which grows in clusters on the ground at the root of the plant, and from it a bright scarlet fruit forms, of a pear shape, and about the size of a small fig. It is divided into four quarters, and contains some white, fleshy pulp, very juicy and acid. This pulp is full of

<sup>1</sup> Cinnum.

<sup>2</sup> *Osmunda regalis* is cosmopolitan, but in tropical zone is high up only.

<sup>3</sup> Mr. Rolfe cannot suggest anything better than *Lissochilus*.

<sup>4</sup> *Selaginella scandens*, no doubt.

<sup>5</sup> "Ribbon fern" would suggest *Ophioglossum pendulum* or *Vittaria*, but they are not like *Davallia pentaphylla*.

<sup>6</sup> *Crinium zeylanicum*, <sup>7</sup> *Brunsvigia toxicaria*.

<sup>8</sup> *Platyserium alcornice* is not African, but *P. Stemmaria* is widely spread.

<sup>9</sup> No doubt *Cyathea Thomsoni*, Baker, which is very near *C. Dregoi* of the Cape.

<sup>10</sup> There are a large number of *Anomoms* in West Tropical Africa. The fruits are ? not scilled. See *A. Daniellii*, &c., in Oliver and Hanbury's paper in Journ. Linn. Soc., vii. 109.

small black aromatic tasting seeds like those of the cultivated cardamom. If ever planters go into Africa, the cardamom will be an important product of the soil for commerce, for there are vast tracts of forest with the climate, soil, and checkered shade which are necessary for the cultivation of the cardamom. Orchilla weed should also become a valuable article of commerce; it grows in many parts of the forest. I consider, however, that when the great forest of Central Africa is opened up to civilization, by far the most valuable article of commerce will be india-rubber, the want of which is increasingly felt in the civilized world. Now that electricity is so much used for various purposes, the demand for india-rubber grows larger and larger; the supply which is shut up in the African forest is practically unlimited. There are various trees of the fig tribe which yield this product, but by far the greatest amount is contained in the india-rubber vines<sup>1</sup> which abound in the forest and hang from almost every tree. In cutting our way through the forest in some places, we got covered with the milky glutinous sap, which dropped upon us from the vines we cut through.

"The natives know its value, and use it largely for smearing the inside of their buckets in order to make them hold water. They use it largely also for covering the ends of their drum-sticks. The india-rubber obtained is of a clear, yellowish colour, like glue, and is of the most elastic description.

"In the forest region I saw no water-lilies, but in Emin Pasha's Province, in the Bari country, I saw two kinds.<sup>2</sup> They were both about the size of an ordinary white water-lily, and the leaves and flowers floated on the surface of the water, but the stalks and formation of the leaves and flowers was finer and more slender. One was of a pink coral-like colour, not white like the Zanzibar lily, and the other of a pale bluish lavender. They were growing in small clear pools only a few miles apart in the valley of the Nile, at an altitude of about 3000 feet above the sea.

"One of the most interesting botanical discoveries I made in the forest was the discovery of a wild orange-tree. During our march through the forest I had continually come upon trees varying from 8 to 15 feet high. They had double leaves of a peculiar shape, which had a delicious smell like orange leaves; the branches were covered with long sharp thorns, and I at once pronounced them to be orange-trees. My fellow officers smiled incredulously, and exclaimed: 'Orange-trees<sup>3</sup> in the middle of the forest!' But I held to my opinion, and just before reaching the open country, I came upon a tree with both flowers and fruit upon it. The flowers were exactly the same as the flowers of a cultivated orange-tree. The fruit, which was green, was about the size of a marble. On cutting through it with a knife I found it had the same divisions as an ordinary orange, but each division was full of small seeds, which were very bitter and aromatic. On reaching Emin's Province I told him about it, and he regretted very much that I had not brought a specimen with me, for he was a good botanist, and wished to add it to his collection of dried plants. He told me my discovery was doubly interesting, as many years before a German had penetrated the forest on the west coast of Africa, and reported that he had found wild orange-trees. His story was discredited, and now our discovering the orange-tree in the forest pointed that his report was after all true.

"I have not space to speak much about the flowers we saw in the open country, but will say a few words about those flowers which we found at a high altitude on the slopes of Ruwenzori, or the Mountains of the Moon.

Lieutenant Stairs who made the ascent of the mountains, gives the following facts in his report:—

"The barometer stood at 21°10, thermometer 70° F. Ahead of us and rising in one even slope stood a peak, in altitude 1200 feet higher than we were. This we now started to climb, and after going up a short distance came upon three heaths. Some of these must have been 20 feet high, and as we had to cut our way foot by foot through them our progress was necessarily slow. Here and there were patches of inferior bamboos, almost every stem having holes in it made by some boring insect, and quite destroying its usefulness. Under foot was a thick spongy carpet of wet moss, and the heaths on all sides of us we noticed were covered with "Old Man's Beard" (*Usnea*). We found great numbers of blue violets which had no smell, and from this spot I brought away some specimens of plants for Emin Pasha to classify. The altitude was 8500 feet. We found blueberries and blackberries<sup>1</sup> at an altitude of 10,000 feet. The following<sup>2</sup> are the generic names of the plants collected as named by Emin Pasha:—

Clematis.	Moschosma.
Viola.	Lissoschilus.
Hibi-cus.	Luzula.
Impatiens.	Carex.
Tephrosia.	Anthistria.
Glycine.	Adiantum.
Rubus.	Pellæa.
Vaccinium.	<i>Peris aquilina</i> .
Begonia.	Asplenium.
Peucedanum.	Aspidium.
Gnaphalium.	Polypodium.
Helichrysum.	Lycopodium.
Senecio.	Selaginella.
Sonchus.	Marchantia.
<i>Erica arborea</i> .	Parmelia.
Landolphia.	Dracæna.
Heliotropium.	Usnea.
Lantana.	Tree Fern.

"These were just a few specimens Lieutenant Stairs brought down with him. But the slopes of Ruwenzori will, when properly explored, yield numbers of unknown treasures to be added to the Botanical Encyclopedia.

"For many weeks we drank coffee which we made from the berries of the wild coffee-trees which abound on the highlands round the great lakes of Central Africa. The Arabian coffee was originally supposed to have come from Kaffa, in Abyssinia. That which we found in Karagwe, Ankori, and Uganda is equal in flavour to the finest Arabian coffee, and will, when Central Africa is opened up, be another of the chief articles of commerce.

"I. A. M. JEPHSON."

#### TOWN FOGS AND THEIR EFFECTS.<sup>3</sup>

UNTIL 1880 the formation of fog was looked upon as arising simply from the separation of liquid water, probably in the form of hollow vesicles, from an atmosphere saturated with aqueous vapour; but in that year Aitken showed that really the determining cause of the separating out of liquid water, and consequent formation of fog, was dust present in the air. He pointed out that a change of state, a gas passing to a liquid, or a liquid to a solid, really always occurred at what he terms a "free

<sup>1</sup> It would be very interesting to have these identified. The two highest-known species of *Rubus* are *pinnatus* and *rigidus*, at 5000-6000 feet.

<sup>2</sup> This list is in Stanley's book. The *Viola* is no doubt *abyssinica*, common to the mountains of Madagascar, Abyssinia, the Cameroons, and Fernando Po. There are three heaths known on the high mountains of Central Africa, viz. *Erica arborea*, *Ericinella Mannii*, and *Blueria spicata*. There is no *Vaccinium* known before in Tropical Africa; though three or four are plentiful in Madagascar, and there is one on the Drakensberg, so that its occurrence is most probable. The ferns of Tropical Africa are nearly all species widely spread in other continents.

<sup>3</sup> The paper by Dr. W. J. Russell, F.R.S., introducing the discussion on Town Fogs at the Hygienic Congress.

<sup>1</sup> Landolphia.

<sup>2</sup> *Nymphaea stellata* and *N. Lotus* are both plentiful in Upper Nile-land.

<sup>3</sup> This reads like a *Citrus*, and if so is an interesting discovery, as no species is hitherto known there.

surface"; that as long as a molecule of liquid water is surrounded by like molecules, and the same with gaseous water, we do not know at what temperature, or whether at any temperature, they would change their state; but if in contact with a solid then at the surface, where they meet, the change will occur; if the solid be ice it may become liquid or the liquid may become solid, and the same kind of action occurs when the liquid is in contact with its own vapour; in fact, that what we call the freezing and boiling-points of a body are the temperatures at which these changes take place at such free surfaces. The dust always present in the atmosphere offers this free surface to the gaseous water, and thus induces its condensation. This specific action of dust varies very considerably, first with regard to its composition, and second with regard to the size and abundance of the particles present. Sulphur burnt in the air is a most active fog-producer, so is salt. Many hygroscopic bodies form nuclei having so great an affinity for water that they can cause its condensation from an unsaturated atmosphere. At the same time non-hygroscopic bodies, such as magnesia and many others, are powerful fog-producers; no doubt their activity may in part be attributed to their being good radiators of heat, and thus becoming cooled, induce condensation. Mr. Aitken also shows that the products of combustion, even when the combustion is perfect, are powerful fog-producers, a fact which has important bearing on the production of town fogs. One other point in these experiments I cannot omit mentioning, it is the exceedingly minute amount of matter capable of inducing fog. In his first series of experiments Mr. Aitken showed that  $\frac{1}{100}$  of a grain of iron wire, however often it was heated, evolved on each heating sufficient dust to cause a visible fog, and afterwards, with still more delicate apparatus, that  $\frac{1}{1000}$  of a grain of either iron or copper, when treated in the same way, gave a similar result, and from these last experiments he infers that even  $\frac{1}{100000}$  grain of either wire, if only slightly heated, would yield sufficient nuclei to cause a visible amount of fog. It is of much importance and interest, seeing how small a quantity of dust is required to produce fog, to know that even this small amount may be filtered out of the air by passing it through cotton wool, and thus an air be obtained in which a fog cannot be produced. Mr. Aitken's description of such an atmosphere is at first most alluring, for he says, if there was no dust in the air there would be no fogs, no mists, and probably no rain; but he goes on to state that when the atmosphere became burdened with supersaturated vapour, it would convert everything on the surface of the earth into a condenser; every blade of grass and every branch of a tree would drip with moisture deposited by the passing air; our dresses would become wet and dripping, and umbrellas useless; but our miseries would not end here, for the inside of our houses would become wet, the walls and every object in the room would run down with moisture. I think, if we picture to ourselves this state of things, we may be thankful that there is dust and fog. Dust in its finer forms is invisible to us; but as its delicate particles become loaded with moisture, it becomes a fine mist, dense if the number of particles are many; if, however, the dust-particles are fewer, and the amount of aqueous vapour the same, each particle will have a larger amount of condensed moisture to carry, and it will give rise to a more coarse-grained fog; the moisture, or some of it, will be more feebly attached to its nuclei, producing then what is known as a wet fog, whereas at least a most important fact in the production of a dry fog is the strong affinity between the nuclei and the condensed vapour. As most of you are no doubt aware, Mr. Aitken has invented a most ingenious method for counting the number of dust-particles in air, and has obtained most interesting and valuable results. I can only mention here that some of

these results deal with the clearness of air in relation to the number of dust-particles present, and other results show how little effect rain has in diminishing the amount of the finer dust in air. Evidently towns will supply dust of all kinds, and therefore offer every inducement for fogs to form there, and that at least some of the particles will be capable of causing the condensation of moisture even from an atmosphere which is not saturated with aqueous vapour. This condensation of moisture is a very complete process for removing all kinds of impurities from the air. Floating particles are free surfaces, and become weighted by the moisture they condense and tend to sink, and even the gaseous impurities in the air will be dissolved and carried down by the moisture present.

Experiment confirms this, for it has been proved how correctly the impurities of an air can be ascertained by determining the composition of dew, even if it be artificially and locally formed. It is of importance to note that even the purely gaseous emanations from our towns cannot pass away when a fog exists, as is shown by the accumulation of carbonic acid which takes place during a fog. Taking 4 volumes in 10,000 volumes as the normal amount of carbonic acid in London air, some years ago I found that it increased in the case of a dense fog to as much as 14.1 volumes, and often to double the normal amount, which must represent a very serious accumulation of the general impurities in the air.

A fog in this way becomes a useful indicator of the relative purity of the atmosphere in which it forms. If pure aqueous vapour be condensed it gives a white mist—a country fog, a sea fog—and a white light seen through it is not converted into a red light; but in town fogs the whiteness of pure mist disappears and becomes dark, in some cases almost black in colour, the change being produced by the foreign matters floating in the air, and by far the most abundant colouring matters of our town fogs are the products generated by the imperfect combustion of coal; but in addition to these bodies, many others must obviously find their way into the air over a town. Especially will there be dust from the universal grinding and pounding going on in street traffic and many mechanical operations, from the general disintegration of substances and the decomposition of perishable materials—all will add something to the air, and it will become an integral part of the fog. However, although it is often said that a town fog is so dense that it may be cut with a knife, still it is difficult to condense so much of it that it can be subjected to a searching chemical analysis. In 1885, by washing foggy air, I was able to determine the amount of sulphates and chlorides present, and as indicators of organic matter the quantity of carbon and nitrogen in the fog. The results showed strikingly how largely the amounts of organic matter and ammonia salts in the air varied with the weather; no case of dense fog occurred when the experiments were being made; but the mean of several experiments clearly showed that in foggy weather the amount of organic matter was double as much as existed in the air in merely dull weather, and that the amount of sulphates and chlorides increased under like conditions, but not to the same extent. Fog may, however, be made to give its own account of its constituents, for we have only to collect and analyze the deposit which it leaves to learn what its more stable constituents are, and we have to thank the air-analysis committee of the Manchester Field Naturalists' Society for the most complete analysis of such a deposit which has yet been made. The deposit analysed occurred during the last fortnight in February of this year (1891), and was obtained from the previously washed glass roofs of the plant-houses at Kew, and Messrs. Veitch's orchid-houses at Chelsea. At Kew 20 square yards of roof yielded 30 grammes of deposit. At Chelsea the same area gave 40 grammes, which represents 22 lbs. to the acre or 6 tons

to the square mile, and the composition of these deposits is as follows:—

	Chelsea, Per cent.	Kew, Per cent.
Carbon ... ..	39.0	42.5
Hydrocarbons ... ..	12.3	4.8
Organic bases (pyridines, &c.) ... ..	2.0	
Sulphuric acid (SO <sub>2</sub> ) ... ..	4.3	4.0
Hydrochloric acid (HCl) ... ..	1.4	0.8
Ammonia ... ..	1.4	1.1
Metallic iron and magnetic oxide of iron ... ..	2.6	
Mineral matter (chiefly silica and ferric oxide) ... ..	31.2	41.5
Water, not determined (say dif- ference) ... ..	5.8	5.3
	100.0	100.0

These analyses give, I believe, for the first time, a definite account of the composition of fog-deposit. Soot and dust are by far its principal constituents, rendered sticky and coherent by hydrocarbons, but I should like to give you the striking description which Prof. Thiselton Dyer has sent me of this deposit, collected at Kew. He says: "It was like a brown paint, it would not wash off with water, and could only be scraped off with a knife. It thickly coated all the leaves of the evergreens, and upon what have not yet been shed it still remains." In the above analysis it is curious to note the large amount of metallic iron and magnetic oxide of iron.

The details with regard to these very interesting analyses we shall hear from a member of the Manchester Committee, and I will only ask you to note how large a proportion of these deposits arises from the imperfect combustion of coal. We also learn from the Manchester Committee some interesting facts with regard to fog-deposits which occurred last winter in their city. This deposit which was collected from Aucuba leaves contained as much as 6 to 9 per cent. of sulphuric acid, and 5 to 7 per cent. of hydrochloric acid, mostly, of course, in a state of combination, but the deposit was, they say, "actually acid to the taste." Also, that three days' fog deposited per square mile of surface, in by no means the worst part of Manchester, 14 cwt. of sulphuric acid, and even as far out of the city as the Owens College, on the same area, over 1 cwt. of acid and 13 cwt. of blacks.

There is still one other point characteristic of town fogs to be noted: it is their persistency in an atmosphere considerably above the dew point. A country fog under such circumstances directly passes away; a town fog apparently does not do so. There seem to me to be two reasons for this: one is that the moisture is protected, and its evaporation to a large extent hindered, by the presence of oily matter; and secondly, when the moisture has really gone, the soot and dust remain, and produce a haze.

The great distance to which fogs will travel is also remarkable, for they have on many occasions been traced to a distance of at least 25 to 35 miles from London, and I believe I might say to 50 miles.

I have so far discussed the production and composition of town fogs, and before considering their effects, would say a word on the question of whether in London they are increasing in frequency and density. A complete and accurate record of fogs in London is not kept; several stations are required, and a correct method of registering the density and distinguishing the difference between haze and fog is necessary; but fortunately there is a fair approximation to this complete registration of London fogs published by the Meteorological Office in their daily reports. The observations are made every morning at Brixton, and every afternoon at Victoria Street, and from a paper by Mr. Brodie, on "Some Remarkable Features in the Winter of 1890-91," published in the *Journal of the Royal Meteorological Society*, I learn that the number of fogs thus registered which have occurred each winter since 1870 is as follows, winter being represented by the months December, January, and February. I have divided these 20 years into four groups of 5 years each:—

logical Society, I learn that the number of fogs thus registered which have occurred each winter since 1870 is as follows, winter being represented by the months December, January, and February. I have divided these 20 years into four groups of 5 years each:—

Between 1870 and 1875,	93 fogs occurred.
" 1875 and 1880,	119 " "
" 1880 and 1885,	131 " "
" 1885 and 1890,	156 " "

It appears, then, that during the last twenty years there has been a steady increase in the number of winter fogs. I am not aware of any data to prove whether the density of these fogs has increased, but it is probable that the increase of number of fogs largely depends upon an increase of atmospheric impurity, and the conversion of haze and mist into obvious fog; and as the great colouring matter of fogs arises from the combustion of coal, I have drawn up the following table from information which has been kindly furnished to me by Mr. G. Livesey and Mr. J. B. Scott, of the Coal Exchange. It gives the amount of coal really consumed annually in London; it does not include the coal used by the different gas companies. For the first five years, the amount given in the table is rather too high, as the quantity used by the suburban gas companies could not be ascertained and deducted. The quantities apply to what is known as the London district—an area, on an average, of 15 miles round London. The table shows an absolute increase, during the last fifteen years, of 2,000,000 tons of coal—that is, half as much again is now burnt as was burnt in 1875.

*Coal consumed in London (that used by Gas Companies deducted).*

Year.	Tons.	Year.	Tons.
1875 ...	4,882,233	1883 ...	5,872,310
1876 ...	4,988,280	1884 ...	5,669,281
1877 ...	4,143,909	1885 ...	6,026,063
1878 ...	4,973,147	1886 ...	6,096,732
1879 ...	5,833,891	1887 ...	6,231,956
1880 ...	5,334,823	1888 ...	6,463,498
1881 ...	5,598,281	1889 ...	6,390,850
1882 ...	5,343,974		

Supposing only 1 per cent. of sulphur in this last yearly amount is converted into sulphuric acid (H<sub>2</sub>SO<sub>4</sub>) and passes into the air; this would give 195,720 tons of this acid.

The five years' averages of winter fogs, we have seen, give a steady increase, but obviously the number each winter will vary much with the atmospheric conditions: for instance, last winter was remarkably favourable for the development of fog; for, again taking the last twenty years, the average number of days of fog during the winter is 25, but last winter the actual number was 50.

The general atmospheric conditions which induce fogs are a still and moist air and a high barometer—a state of the air most usual under anticyclonic conditions. The immediate determining cause, however, of a fog is usually a sudden and considerable fall of temperature. Mr. Brodie also points out that last winter was a time of calms; the percentage of such days on the average for the last twenty years is 9.7, but last winter the number was 22. Emphatically, he says, it was an anticyclonic winter.

A form of fog, well termed a "high fog," now frequently occurs in London. The lights in a street during this form of fog are often as visible as on clear nights, but above hangs a fog so dense that the darkness of night may prevail during the day. This particular form of fog appears

to have become much more frequent of late years, and, in fact, it is doubtful whether in former times it ever occurred. The immediate cause of this new form of fog is difficult to explain.

London has always been the head-quarters of town fogs, but now all the large towns appear to be emulating it in this respect, and this is what we must expect; an increase of population means an increase of combustion of coal, and that implies a pouring into the atmosphere of more and more carbon, hydrocarbons, and sulphuric acid. In dry and windy weather all these bodies may be scattered so as not to produce appreciable effects; but let the air be still, and even approach a state of aqueous saturation—then, we have seen, every particle of dust and dirt becomes a centre for moisture to deposit on, and we shall have a fog imprisoning all impurities and offering them to us for inhalation. To burn coal so that only

ascertain how far such views were correct, I studied the Registrar-General's reports for the times of fogs; but, as I found it difficult to interpret the figures, I have expressed them by the curves upon these somewhat lengthy diagrams (Figs. 1, 2, and 3). I have selected times of fog, viz. the winters of 1879-80, 1880-90, and 1890-91, and have represented graphically the temperature, the amount of fog, and the death-rate for each day.

The results are, I think, worthy of careful study. The first thing we learn from these diagrams is that by far the greater number of fogs occur when there is a great fall of temperature; and clearly this is closely followed after a few days by a great increase in the death-rate; but how much of this increase is to be attributed to the fog and how much to the fall in temperature may be difficult to determine; but we have evidence that when fogs occur without fall of temperature they do not appear to be followed

*Explanation of Diagrams.*—The amount of fog is represented by the small dark patches, the denser the fog the deeper the patch; thus the Registrar-General reports that it is either haze, foggy, fog, thick fog, or dense fog. These different degrees of fog are represented by the vertical thickness: thus dense fog is 5 times as deep as haze, and so with the other designation.

The horizontal line represents the average temperature for each day for the previous 20 years, and also the average weekly death-rate from diseases of the respiratory organs for the previous 20 years.

The curved line represents the divergence of temperature from the daily average, and the shaded part the divergence of the death-rate from the average.

Scale:  $\frac{1}{2}$  inch represents 1 day,  $1^{\circ}$  F., and 10 deaths.

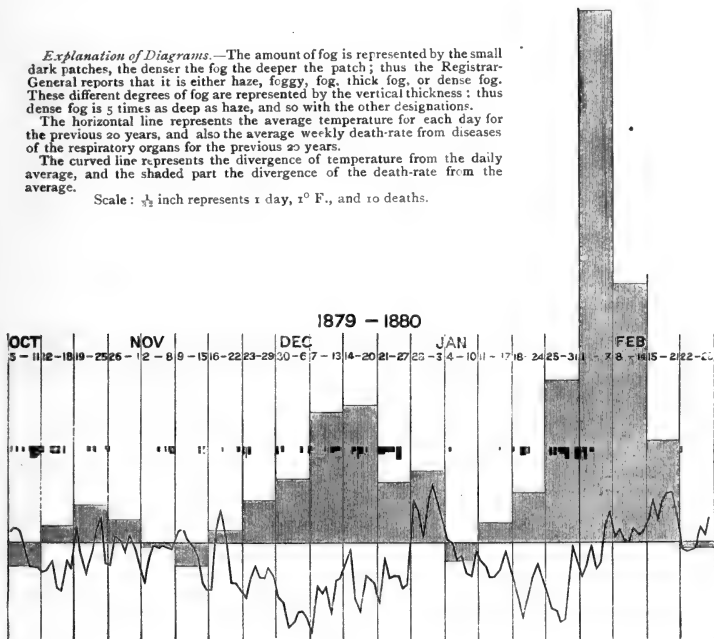

FIG. 1.

products of complete combustion shall escape is a problem of much difficulty, and is comparatively rarely done. Certainly the domestic fireplace does not do it, but, on the contrary, is the principal cause of the dark colour of our fogs. Many manufacturers, however, liberally contribute to produce the same effect.

I turn now from the constitution and production of fog to note some of the effects it produces. First, with regard to health, details on this point I leave to those who are more able to describe them than I am, but I have a few words to say with regard to the effect of London fogs on the death-rate in general. There are many people who feel so strongly the unpleasantness of fog that it induces them to magnify its results, and make extraordinary statements with regard to the mortality it produces. It has even by some been likened in deadliness to the Great Plague of London, and to other great epidemics. To

by any remarkable increase of death-rate; for, on December 15, 1889, there was a dense fog, and the temperature was even above the average; under these conditions the death-rate remained far below the average. On December 13 and 14 in the same year, again, there is a dense fog, an average temperature, and only an average death-rate; and the same thing happens on February 4 in 1890, when, notwithstanding a dense fog, the death-rate remained remarkably low; and last winter, on November 13 and 14, there was again a dense fog, a high temperature, and an average death-rate. With these four exceptions depression of temperature goes with fog. There is no case of depression of temperature not followed by increase of death-rate.

That many people suffer much, both physically and mentally, from the effects of fog, there can be no doubt; but, as far as I can interpret these returns of the Registrar-

General, they do not confirm the popular impression that fog is a deadly scourge; at the same time, it is beyond doubt that an atmosphere charged with soot, dust, and empyreumatic products is an unwholesome atmosphere to breathe; but I think that the principal cause of the great increase of death when fogs occur is attributable rather to the sudden fall of temperature which usually accompanies fog, than to the fog itself.

So many toxic effects are now traced to the action, direct or indirect, of bacteria, that it is satisfactory to

bare, and it is impossible ever again to recover them into sightly specimens. (2) The toxic influence of the fog. This is most striking. It is illustrated in the most forcible way by the inclosed memorandum. I attribute it in the main to sulphurous acid, though I cannot help suspecting that some hydrocarbon may also have something to do with it. The toxic effect varies from one plant to another, some are scarcely injured, others are practically killed." He adds:—"I hope you will be able to arouse some interest in this horrible plague. If the visitation of

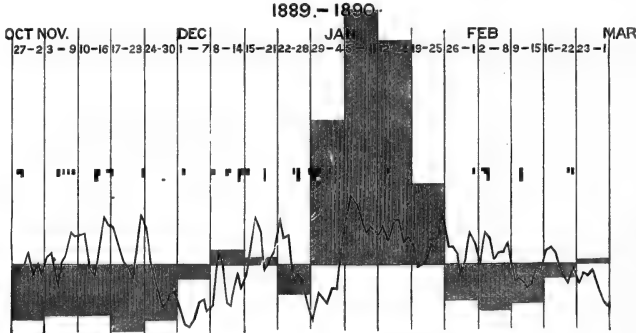

FIG. 2.

learn, from the experiments of Dr. Percy Frankland, that fogs do not tend to concentrate and nurture them, for he found there were remarkably few bacteria in London air during a time of fog. The deleterious action of town fogs on plants is more marked and more easy to investigate than its effect on animals. Nurserymen have long known from experience that a town fog will penetrate even their heated greenhouses, and with certainty will kill many of their plants, specially their orchids,

last year is annually repeated, it must in time make all refined horticulture impossible in the vicinity of London."

I append to this paper the very interesting and important report to which Prof. Dyer refers, from Mr. W. Watson, "On the Effect of Fog on Plants grown at Kew." This fog action on plants is so clearly marked, and so deadly, that it has, I am happy to say, led the Horticultural Society, aided by a grant from the Royal Society, to undertake a scientific investigation of the matter. Plants

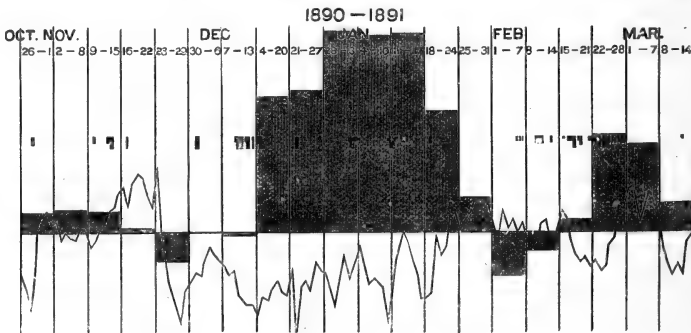

FIG. 3.

tomatoes, and, in fact, most tender and soft-wooded plants; but on this point, I cannot do better than read to you what the Director of Kew Gardens, Prof. Thiselton Dyer, says in a letter to me:—"With regard to plants under glass, the effect of fog is of two kinds—(1) By diminishing light. This checks transpiration. The plants are therefore in the condition of being over-watered. A well-known consequence of this is to make them shed their leaves wholesale. Many valuable plants which ought to be well furnished with foliage become perfectly

are so much more easily dealt with than people, all the circumstances of their attack by the fog and its immediate results so much more easily noted and traced, that the investigation has already yielded important results, and we shall, I hope, hear from Prof. Oliver—who is devoting himself specially to the investigation—some account of his latest results. A marked and admitted difference between town and country fog is, that while a country fog is harmless in a greenhouse, a town fog will produce most destructive results.



There is still another action of town fogs, and one which I believe is of great importance. I mean its power of absorbing light. This power of abstracting light depends principally on the amount of coal products which the fog contains. The slower-vibrating red rays can struggle through a fog which is absolutely impervious to the more refrangible ones. Even a mist but slightly tinged with smoke is opaque to the blue rays, and thus screens us from their action but as Aitken has lately shown, the heat rays can pass readily through. This opacity of town fog to light is, I believe, one of its most serious and detrimental characters. Animals can no more thrive in semi-darkness than can plants; and, important as the red rays may be, still it is undoubtedly the blue rays which are most active in producing the principal chemical changes going on around us. Experiments lately made have strongly impressed me with the wonderful activity which light confers on a mixture of air and moisture, oxidations which in dullness and darkness are impossible are easily and rapidly effected by aid of a gleam of sunshine, or even a bright diffused light. It is not possible, I believe, for people to remain healthy where this source of chemical activity is cut off, or even seriously diminished. In addition to the loss of physical energy, mental depression is induced by the absence of light, the whole tone of the system becomes lowered, and may be a prey to actions which, under brighter conditions, it would have been able to resist.

There is another action of light which is potent for good. I mean its destructive action on many forms of bacteria. Prof. Koch, at the last meeting of this Congress, pointed out how his tubercle bacilli are killed by even a short exposure to sunlight, and it is now well established how inimical light is to the growth and development of most kinds of bacteria. I wish I could show you in some perspicuous way the enormous power which town fog has of absorbing light, and bring forcibly before you the great difference which exists between the amount of light which reaches the inhabitants and buildings of a town, as compared to the amount on an equal area free from smoke. A simple actinometer is much required, and I hope the want will soon be supplied; but at present the only records bearing on this point are the observations of direct sunshine made at various stations, by the Meteorological Society and Meteorological Office, with the Campbell-Stokes instrument, and some interesting observations, by Mr. H. Raffles, on the distance at which objects were visible during a London winter.

First, with regard to the sunshine experiments. One

Hours of Sunshine during the Year 1890.

	Bunhill Row.	Greenwich.	Kew.	Aspley Guise.	Eastbourne.
January ...	29.9	44.0	56.0	57.3	56.9
February ...	42.4	62.8	57.8	70.5	106.5
March ...	71.3	90.8	109.3	110.4	133.5
April ...	127.4	141.5	144.8	137.3	170.1
May ...	215.7	223.9	223.9	214.3	267.9
June ...	128.0	125.2	141.4	119.1	165.3
July ...	134.1	120.6	139.9	141.3	185.6
August ...	164.0	153.1	182.5	189.5	200.2
September ...	131.6	153.2	169.5	166.1	207.4
October ...	89.6	96.9	121.6	135.6	125.3
November ...	23.4	40.8	57.6	64.7	66.9
December ...	0.1	2.4	0.3	13.4	38.0
Total ...	1157.5	1255.2	1404.6	1419.5	1723.6

station is situated in the heart of the City, in Bunhill Row, and it is of much interest to compare the amount of

sunshine there with, first, the amount in the immediate neighbourhood of London, where we are not beyond the effect of town fogs, viz. at Greenwich on one side, and Kew on the other, and also with a place not far from London, which is beyond the influence of its smoke, viz. Aspley Guise, near Woburn. I have also noted the results obtained at Eastbourne, which is about as far distant from London as Aspley Guise, but in the opposite direction, and is one of the sunniest places in England.

Taking the totals of last year, the table shows that the hours of sunshine registered at Bunhill Row were 1158, at Greenwich 1255, at Kew 1405, at Aspley Guise 1420, and at Eastbourne 1724; but for our present purpose we must compare the amounts of sunshine at these places during the winter months—November, December, January, and February—and we find that at Bunhill Row there were 95.8, Greenwich 150, Kew 171.7, Aspley Guise 205.9, and at Eastbourne 268.3 hours of sunshine; that is, if Aspley Guise be taken as giving the normal amount, Bunhill Row received only half its due amount, and at Eastbourne there was nearly three times as much sunshine as in the City. Now, on comparing the two other periods of 4 months, which are comparatively free from fogs, the amount of sunshine is far more nearly the same at all stations.

	Bunhill Row.	Greenwich.	Kew.	Aspley Guise.	Eastbourne.
March till June ...	542.4	581.4	619.4	581.1	736.8
July till October ...	519.3	523.8	613.5	632.5	718.5

Mr. Raffles, during the winter of 1887-88, which it should be noted was remarkably free from fogs, made a series of observations of the distances to which he could see from Primrose Hill, and found that looking south on the 152 consecutive days from November to March, only on 78 days could he see a quarter of a mile, and only on 83 days could he see to the same distance in a south-westerly direction: this conveys a good idea of the opacity of our London atmosphere.

We attempt to compensate for the darkness which fogs cause by the use of artificial light, and I have again to thank my friend Mr. Livesey for the information he has given me with regard to the extra quantity of gas burnt in London during a day of fog. He tells me that if a dense fog covered the whole of London, and lasted all day, the additional amount of gas consumed would be 30 million cubic feet; but since so extensive a fog as this probably never exists, and certainly never lasts all day, the actual amount consumed may be correctly reckoned at 25 million cubic feet; and if the cost of this be calculated at 2s. 6d. per 1000 cubic feet, which is rather below than above the actual cost, it amounts to £3125; but after all, it is not the single days of dense fog that measure the extra amount and cost of artificial light used on account of fog—it is rather the continually occurring dull days and local transitory fogs which demand an extra supply of gas, and this is often 5 to 15 million cubic feet in a day, and gives a total by the end of the winter which is very considerable. As a standard of comparison, I should state that the total consumption of gas in the London district in a day of 24 hours, during the depth of winter, is 140 million cubic feet.

Such, then, is an imperfect outline of the chief features and effects of town fogs; and now what is to be said with regard to the possibility of getting rid of such fogs? This question, it seems to me, resolves itself into this: fogs cannot be prevented from forming over towns; there are, and probably ever will be, special inducements, in the way of dust particles and products of combustion, for fogs to form there; but whether they must always be dark in

colour, and loaded with soot and tarry matter, is another question. The answer involves not only chemical but also social considerations. With regard to the first, my answer is that as long as coal is burnt you will have dense fogs; grates, kitcheners, furnaces, may be, and probably will be, much improved, and fires may be stoked in a better way, but that the improvements will be so great that all imperfect combustion will cease I think is improbable; if this be so, there is only one other alternative, as long as coal is our source of heat: it is to alter our form of fuel and adopt gas and coke; the soot and tarry matters will be then done away with; the question of sulphuric acid in the air would remain, but our fogs would at least be white. There is still the social part of the question, which is not without serious difficulty—namely, how to induce or compel people to give up the use of coal. At the present day it would not be possible to do as it is recorded was done in the reign of Edward I., try, condemn, and execute a man for burning coal in the City of London.

W. J. RUSSELL.

#### *Effects of Fog on Plants Grown in the Houses at Kew.*

The heavy fogs experienced in the last two or three winters injured many plants in the houses at Kew. When thick fog occurred almost daily, the injury it did to many plants amounted practically to destruction. The leaves fell off, the growing point withered, and in some cases, such as Begonias and Acanthads, the stems also were affected. Flowers, as a rule, fell off as soon as they opened, or whilst in bud. Almost all flowers which expanded were less in size than when there was no fog. The flower buds of *Phalænopsis*, *Angræcum*, some Begonias, Camellias, &c., changed colour and fell off as if they had been dipped in hot water.

In the Palm-house bushels of healthy-looking leaves, which had fallen from the plants, were gathered almost every morning. Plants which appeared to be perfectly healthy, when shaken would drop almost every leaf. Herbaceous plants suffered most, *i.e.* Begonias, Poinsettias, Bouvardias, Acanthads, &c. Some herbaceous plants, however, did not suffer at all, nor were their flowers injured, as, for instance, Cyclamen, Primula, Hyacinth, &c. Many hard-wooded plants lost their leaves and were otherwise damaged, viz. *Boronias*, some *Heaths*, *Grevilleas*, *Acacias*, &c. *Protea cynaroides*, a Cape plant with large laurel-like leaves, was much injured in the temperate house (minimum temperature 40°), the leaves turning black as though scalded. The same species, however, in another house where the atmosphere is drier and the temperature a few degrees higher, was scarcely affected by fog.

As a rule, the plants that were in active growth suffered most. Monocotyledonous plants and ferns for the most part were not appreciably affected by the fogs, the injury they suffered, especially last winter, being clearly due to low temperature. The effect of fog on flowers is remarkable. Generally, white flowers are destroyed, but there are some notable exceptions—viz. *Masdevalia tovarensis*, *Odontoglossum crispum*, and *Angræcum* amongst Orchids, and *Crinum* and white Cyclamen, white Hyacinths, white *Chrysanthemums*, &c.

The green leaves of *Poinsettia pulcherrima* all fell off, whilst the red ones (bracts) remained, as also did the flowers. All *Calanthes*, of whatever colour, lost their flowers. The buds of the white-flowered *Angræcum sesquipedale* turned black as if boiled, whilst those of *A. eburneum*, also white-flowered, were not injured, and developed properly. These two plants are grown in the same house under identical conditions, and they come into bloom about the same time.

The conditions most conducive to rest from growth—viz. a low temperature and moderately dry atmosphere,

together with diminished light, unavoidable during the prevalence of fog—were proved at Kew to be the safest for all plants during the prevalence of heavy fogs.

July 25.

W. WATSON.

#### THE ANATOMY OF THE DOG.<sup>1</sup>

THE dog has played by far the most important part in the elucidation of the difficult problems of physiology and pathology presented by the higher animal organism. It is by a firm reliance on the results of experimental researches, conducted largely upon this animal, that the modern physician is enabled to form some idea as to the causation of the symptoms of disease in man, and the mode of action of the remedies which he employs; while the modern surgeon, after a preliminary testing of an operation upon the dog, fearlessly proceeds to attack the most deeply-seated tumour, and to explore the most hidden recesses of the human organization. What, after all, are the services of friendship and companionship, or the more menial duties which are often laid upon the dog, compared with the alleviation of human suffering and the advancement of human knowledge for which he has served as the passive instrument, and this (*pace* the mendacious asseverations of fanatical essayists) at the expense of the least possible amount of suffering to himself?

For these reasons, to the physiologist, the pathologist, the pharmacologist, and the scientific surgeon, a book which, like the one before us, endeavours to deal with the anatomy of the dog in the same detailed and systematic manner in which the structure of man is dealt with in text-books of human anatomy cannot fail to be of the utmost value. To the comparative anatomist it will prove an important addition to the limited existing series of monographs dealing in detail with vertebrate types, while to the veterinarian it will be an indispensable *vade mecum*, both in study and in practice.

For the work is done excellently well, a result which might be anticipated from the manner in which it has been set about. Not only has it been carried on under the auspices of a scientific anatomist so well known as Prof. Ellenberger and in a veterinary school where an unlimited supply of subjects was available for dissection, but with a far-sighted liberality, for which the Saxon Government is much to be congratulated, all the expenses for material and instruments have been defrayed by the State, and one of the collaborators has been enabled to devote his whole time during a period of two years entirely to the labour incident upon the preparation of this work.

The book is a large octavo of 650 pages, containing 208 woodcuts, a few examples of which are here reproduced. There is, in addition, an appendix of 37 lithographed plates, representing in outline frozen sections through the trunk and limbs. A study of these is in itself sufficient to make out the relations of the organs to one another, and the authors have accordingly burdened the text as little as possible with topographical details. Historical and developmental references are entirely avoided, partly for the reason that the facts are not materially different from those which are found in other mammals, partly because they have been dealt with, especially for the dog, in other works, and largely because it was obviously desirable not to increase the bulk of the work. References to literature are also for the most part omitted, for although other works have been consulted, it is claimed by the authors that the present account is

<sup>1</sup> "Systematische u. topographische Anatomie des Hundes." Bearbeitet von Dr. W. Ellenberger, Professor an der tierärztlichen Hochschule in Dresden, und Dr. H. Baum, Prosektor an der tierärztlichen Hochschule in Dresden. (Berlin: Paul Parey, 1895)

based almost exclusively upon original dissections and preparations.

It might be supposed that the striking differences, both in size and in shape, which are presented by dogs

ties which result therefrom, are, as might be supposed, not ignored by the authors of this book. But they remark hereon that apart from differences in size, rendering absolute measurements of little value, the racial

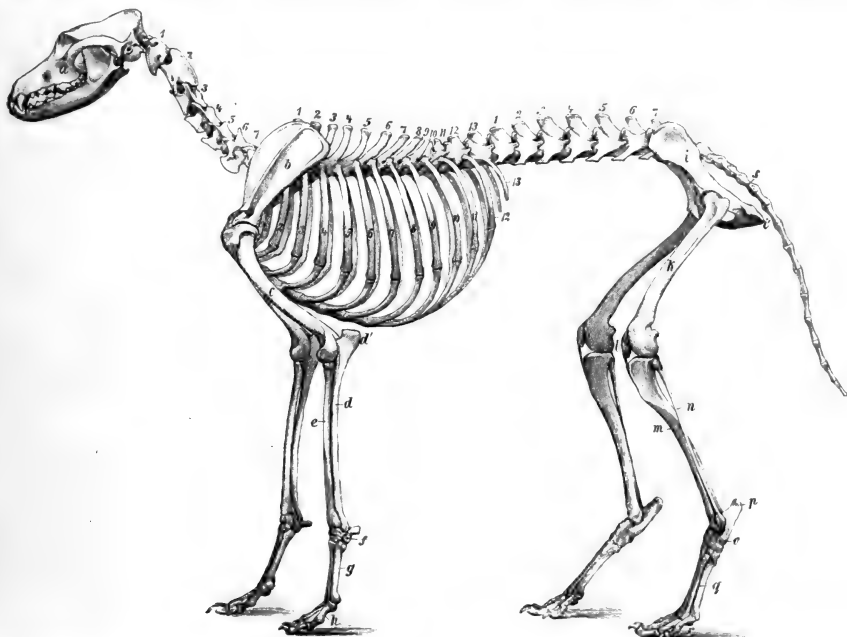

FIG. 1.—Skeleton of the dog. *a*, skull; *b*, scapula; *c*, humerus; *d*, ulna; *e*, olecranon; *e*, radius; *f*, carpus; *g*, metacarpus; *h*, phalanges of fore-foot; *i*, pelvis; *j*, tuber ischii; *k*, femur; *m*, tibia; *n*, fibula; *o*, tarsus; *p*, tuber calcanei; *q*, metatarsus; *r*, phalanges of hind-foot; *s*, coccygeal vertebra. The cervical, thoracic, and lumbar vertebrae and the ribs are respectively numbered consecutively.

of races so different from one another as, to take extreme cases, the greyhound and the pug, would be accompanied by such structural peculiarities as to render a general

differences are almost entirely confined to the skeleton and to certain parts of the muscular system, no important differences being manifest in the position of the muscles,



FIG. 2.—Fore-foot of the dog. *a*, carpal ball; *b*, ball of the sole; *c*<sub>1</sub> to *c*<sub>4</sub>, balls of the toes.

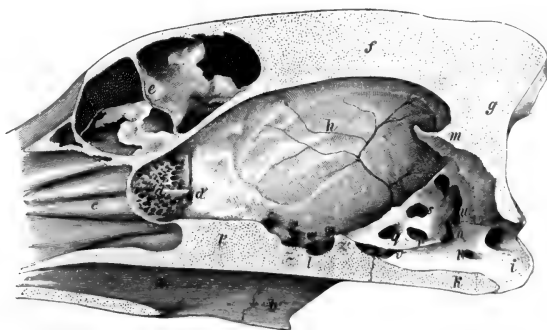

FIG. 3.—Section of skull, displaying the interior of the cranial cavity, and the frontal sinuses. The foramina of exit of the cranial nerves, and the impressions of the cerebral convolutions on the inner surface of the cranium are well shown.

anatomical account of the dog of less value than that of animals in which racial characteristics are less exaggerated. The differences which are found, and the difficul-

vessels, nerves, and viscera; and even in crook-legged dogs, such as the dachshund, in spite of the twisting of the extremities, the topographical relations of the muscles

to one another, as well as to the vessels, nerves, and bones, remain completely unaltered. The only racial characteristics, therefore, which are dwelt upon are those of the skeleton, and especially of the skull, in illustration of which the authors reproduce some of the excellent figures of Nathusius.

Classifying them with regard to their racial peculiarities, the skulls of dogs are divided into two large groups, viz. (1) *Dolichocephalic*, to which belong such dogs as the greyhound, collie, poodle, St. Bernard, and Newfoundland; and (2) *Brachycephalic*, including, amongst others, the pug and bulldog. These groups, however, do not include all dogs, some varieties being intermediate. The difference depends upon the relative development of the face as compared with the brain-capsule, for in the dolichocephalic the face is about two-thirds as long as the brain-capsule, while in the brachycephalic it is only about one-third as long. The former have a strongly marked, bony sagittal crest and a narrow brain-capsule; in the latter the sagittal crest is absent, and the brain-capsule wide. The jaws and dental arches are straight and extended in the dolichocephalic; short and rapidly con-

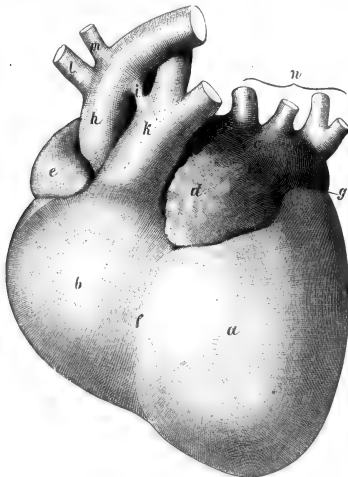

FIG. 4.—Dog's heart, viewed from the left side. *a*, left ventricle; *b*, right ventricle; *c*, left auricle; *d*, its auricular appendage; *e*, right auricle; *f*, groove between right and left ventricles; *g*, coronary groove; *h*, aorta; *i*, ligamentum Botalli; *k*, pulmonary artery; *j*, innominate artery; *m*, left subclavian; *n*, pulmonary veins.

verging in the brachycephalic; in the former the pre-molars are set straight, with well-marked intervals; in the latter they are closely packed, and set obliquely. The racial peculiarities of all the several bones of the skeleton are referred to, and a comprehensive table of pelvic measurements of the different races is given.

It would carry us too far to draw attention to all the details of a work like this, but there are certain points which deserve special mention. Amongst these may be enumerated the exact manner in which each individual bone is described and illustrated; the descriptions of the teeth, short but sufficient, including their dates of eruption; the account of the individual muscles and groups of muscles, with their action; the descriptions of the viscera and of the vascular and nervous systems; and last, but not least, the general excellence of the illustrations, in which the muscles, the blood-vessels, and the nerves are shown up by the aid of colours and differences of shading in a manner which gives a diagrammatic clearness to what appear to be drawings made from actual

dissections. Special mention may also be made of the section devoted to the cerebral hemispheres, the convolutions and fissures of which are minutely described and illustrated both by diagrams and artistic representations. The diagrams which are used to elucidate the distribution of the vagus and sympathetic nerves are a model of clearness; a reference to recent observations on the distribution of white and grey fibres in these and other nerves would, however, have added much to the physiological value of this section. It is also to be remarked that the sense-organs are somewhat lightly touched upon; but in the case of the eye and its connections with the brain, the student is enabled to supplement the account given by the authors by a bibliography of the subject extending over the last twenty-five years.

A table showing the arterial and nervous supply of all the organs of the body, including each muscle and the several parts of the skin, occupies about twenty pages at the end of the book, and will add greatly to its value. An excellent index must also be mentioned, especially as an index is often conspicuous by its absence in German scientific works. In its printing and general get up the book is worthy of the pains which have been bestowed upon it by its authors and of the distinguished physiologist, Prof. Carl Ludwig, to whom they have inscribed a dedication. It is to be hoped that we may soon be able to welcome this work in an English form.

#### NOTES.

A COMMITTEE has been formed at Cambridge to raise a fund to obtain a portrait of Prof. Michael Foster. The portrait will be presented either to the University or to Trinity College, as the subscribers may decide. Among the members of the committee are the Vice-Chancellor, the Provost of King's, the Masters of Trinity, Jesus, and Downing Colleges, Sir George Stokes, M.P., Sir George Paget, Sir George Humphry, Prof. Jebb, M.P., Prof. Darwin, Prof. Newton, Prof. Roy, Prof. Stanford, Prof. Stanton, and Prof. Thomson. Dr. Lea, of Gonville and Caius College, is the treasurer of the fund.

The celebration of Prof. von Helmholtz's seventieth birthday, deferred from August 31, was held on Monday last at Berlin. He was congratulated in the warmest terms by the Minister of Education, and by representatives of many scientific Societies. Prof. du Bois Reymond, acting on behalf of the Helmholtz Medal Committee, handed to Dr. von Helmholtz the first medal, and said that numerous contributions to the Helmholtz Fund had flowed in from all parts of the world, and that the Berlin Academy of Science, with the Emperor's permission, had undertaken the trusteeship. In the evening over 500 guests attended a banquet at the Kaiserhof Hotel.

We regret to have to record the death of Dr. H. K. H. Hoffmann, one of the most distinguished German botanists. He died on October 27. He had been for many years Professor of Botany at Giessen and Director of the Botanic Institution there. Prof. Hoffmann was in his seventy-third year.

WITH reference to the article on "Existing Schools of Science and Art" in NATURE of October 8 (vol. xlv. p. 547), Mr. O. S. Dawson writes:—"It was stated at the meeting that the St. Martin's School of Art 'had closed its doors.' I find this to be incorrect. Certain changes have been made, but I am glad to be able to state that this school (one of the oldest and best known in the country) is flourishing under the new head-master, Mr. Allen."

THE interest excited by the question of the compulsory study of Greek brought to Cambridge on Thursday, last week, the largest number of members of the Senate ever gathered in the Senate House. The proposal that the question should be made a subject of official inquiry was rejected by 525 votes against 185.

The Museums and Lecture Rooms Syndicate, Cambridge, have accepted on behalf of the University a cast of the model executed by the late Sir J. E. Boehm, R.A., for his statue of Mr. Charles Darwin. The cast has been presented by Mr. Darwin's family, and is now placed in the lecture-room of comparative anatomy.

A SOCIETY for the encouragement of the study of natural science has recently been formed at the University of Edinburgh. In commemoration of the fact that Darwin was once a student of the University and a member of a similar society, it has been named the Darwinian Society. The inaugural address is to be delivered by the President, Prof. J. Cossar Ewart. Mr. J. Graham Kerr (late naturalist to the Pilcomayo Expedition) is chairman.

THE anniversary meeting of the Mineralogical Society will be held on Tuesday, November 10, at 8 o'clock. After the election of officers and Council, the following papers will be read:—analysis of aragonite from Scotland, by J. Stuart Thomson; on minerals from the apatite mines near Risør, Norway, by R. H. Solly; notes on the minerals from the hematite depo of West Cumberland, by the same; mineralogical notes from Torreón, Chihuahua, by Henry F. Collins; on the pinite of Breage in Cornwall, by J. H. Collins; on the occurrence of danalite, by H. A. Miers and G. T. Prior.

ON Tuesday, Dr. Burdon Sanderson delivered the first of the Croonian Lectures before the College of Physicians in the new lecture-room at the Examination Hall. The remaining lectures will be given on the next three Tuesdays of November. The subjects are the etiology of inflammation and of the acute specific diseases, and natural and acquired immunity.

SIR DOUGLAS GALTON, F.R.S., has been asked to investigate and report upon the sanitary state of Florence. He is to make any recommendations and suggestions that he may deem necessary.

AT a meeting of the Senate of the University of Sydney on September 21, it was resolved that Prof. Thorpe and Prof. Ramsay should be asked to select and appoint a Demonstrator of Chemistry to take office at the Sydney University on March 1 next, the salary to be at the rate of £350 per annum, and £60 to be allowed for passage money, such sum to be refunded if the Demonstrator should resign his office before the expiration of two years from his appointment. The appointment of a new Demonstrator has been rendered necessary by the resignation of Mr. F. B. Guthrie, who has been made Analyst to the Department of Agriculture.

THE Society of Arts has completed its arrangements for the approaching session. The first meeting will be held on Wednesday, November 18, when the opening address will be delivered by the Attorney-General, Chairman of the Council. At subsequent ordinary meetings (four of which, in addition to the opening meeting, will be held before Christmas) the following lectures will be delivered:—Measurement of lenses, by Prof. Silvanus P. Thompson, F.R.S.; secondary batteries, by G. H. Robertson; the World's Fair at Chicago, 1893, by James Dredge; spontaneous ignition of coal, and its prevention, by Prof. Vivian B. Lewes; burning oils for lighthouses and lightships, by E. Price Edwards; dust, and how to shut it out, by T. Pridgin Teale; typological museums, by General Pitt Rivers; Iceland, by T. Anderson; artistic treatment of jewellery and personal ornament, by J. W. Tonks; agricultural banks for India, by Sir William Wedderburn. The following Cantor Lectures will be given on Monday evenings:—The pigments and vehicles of the old masters, by A. F. Laurie (three lectures, November 30, December 7, 14); developments of electrical distribution, by Prof. George Forbes, F.R.S. (four lectures,

January 25, February 1, 8, 15); the uses of petroleum in prime movers, by Prof. William Robinson (four lectures, February 29, March 7, 14, 21); mine surveying, by Bennett H. Brough (three lectures, March 28, April 4, 11); recent contributions to the chemistry and bacteriology of the fermentation industries, by Dr. Percy Frankland (four lectures, May 2, 9, 16, 23). A special course of six lectures, under the Howard Bequest, will be delivered on Friday evenings:—The development and transmission of power from central stations, by Prof. W. Cawthorne Unwin, F.R.S. (February 5, 12, 19, 26, March 4, 11).

LAST week the Speaker of the House of Commons, responding to a toast at the annual Mayoral banquet at Warwick, gave some sensible advice about technical education. He was afraid, he said, that there was great danger of the sums granted for the promotion of technical education being frittered away. What they wanted to teach was not a trade, not the particular manipulation of the article students might have to deal with in after life, but the principles of science as applicable to the art. Their object should be to elevate the students above the mere manual dexterity of the special professions to which they were to belong.

ON November 12, Mr. E. J. Humphrey will read a paper before the Camera Club on a new method of photography by artificial light. According to the *Journal of the Camera Club*, Mr. Humphrey promises a process of considerable novelty and value in practical work.

DR. ELISHA GRAY lately read before the Chicago Electric Club a paper in which he urged the importance of the International Congress of Electricians which is to be held in connection with the World's Fair at Chicago in 1893. The Congress, he thinks, should be divided into sections according to the various interests represented, one section being devoted to the purely scientific aspects of the subject. "Success," he said, "will be assured from the beginning if all our interested friends act harmoniously, and are actuated by one common desire that the best thing shall be done, without regard to geographical boundaries or local prejudices." Commenting on the paper, Mr. Parker pointed out that, owing to the supremacy which America enjoys in the practical development of industrial electricity, the electrical department would be the most interesting and attractive feature of the Exhibition. He held, therefore, that the directors of the Exhibition should give priority to this department in all arrangements, and should do all in their power to render the Electrical Congress a successful gathering.

PROF. WARD, the mineralogist, of Rochester, New York, has offered to send his collection of geological specimens to the Chicago Exhibition. It is said to be one of the most valuable collections in the United States.

ON Wednesday, October 28, a terrible earthquake visited Nipon, the island which forms the larger part of the Japanese Empire. The area over which the shocks were felt was wider than was at first supposed. It extended inland to the region of the lakes. The principal shock lasted less than two minutes, but was of extreme violence. The subsequent shocks were not strong enough to have done damage in ordinary circumstances, but they sufficed to shake down walls already cracked, and added immensely to the terrors of the night. The *Times* correspondent, telegraphing from Hiogo on November 2, says that great fissures had appeared in the ground at many points, rendering roads impassable and travelling dangerous; and that there had been a remarkable subsidence of the land to some depth over large tracts of country. The volcanic mountain Nakusan belched forth enormous masses of stones and continuous streams of sand and mud, and the contour of the mountain has been completely changed by the eruption. The greatest havoc

seems to have been caused at Ogaki, where at least 1000 persons were killed, chiefly by falling buildings. Both there and at Gifu the earthquake was followed by fires, in which many perished. At Kitagata, Ichinomiya, Tiraguna, Kiyonsu, Kamatsu, and other places, chiefly along the coast, great damage was done. The city of Nagoya suffered to a less extent, although seriously. Much distress prevails in the ruined towns, and the Government is embarrassed in its efforts by the prevailing panic, and the absence of means of communication, telegraph lines and many miles of railway having been destroyed. Exact details as to the extent of the calamity will probably not be obtained for some time. On November 2 the following was the official estimate: killed, 4000 persons; injured, fully 5000; houses destroyed, 50,000.

A GREAT rush of migratory birds seems to have passed over Dublin during the night of May 4 last, evidently on the way to their northern breeding-haunts. An account of the matter is given by Mr. Allan Ellison in the new number of the *Zoologist*. "While sitting in our rooms in Trinity College, about 11 p.m.," he says, "we were attracted by the loud call-notes of birds passing overhead. The night was calm and cloudy, not very dark. We listened at the open window until about 1 a.m., when they seemed to be still passing over in undiminished numbers. They were mostly golden plovers and dunlins, easily recognized by their notes, but we frequently heard the cry of the whimbrel, or the shrill call of the common sandpiper. It was most curious to hear these notes, at first far away towards the south-west, gradually becoming louder as the flocks drew nearer and passed overhead, and then rapidly passing away to the northward. Sometimes the whole air seemed full of their clear whistling notes: in one direction the loud, short pipe of the golden plover, in another the shrill wheezing cry of the dunlin, reminding one of the sound made by a whistle with a pea in it. Sometimes a bird or two would fly quite close over the house-tops, uttering its loud whistle close to the open window, but they seemed for the most part to fly at a great height."

ONE large meteorite and two fragments were lately received by the Government Central Museum, Madras, through the Board of Revenue. Mr. Edward Thurston, the Superintendent of the Museum, quotes in his report for 1890-91 the following statement, by the Tahsildar of Tirupatūr, in the Salem district, as to the conditions under which these stones fell:—"On June 4, 1890, about 8 a.m., there was a sudden clap of thunder, accompanied by an unusual rumbling noise. At this time two stones are said to have fallen in the village of Kakangarai. The fall of both the stones occurred at the same time in adjacent fields, and was witnessed by rayats, who were ploughing close by at the time. One stone appears to have been broken up and divided among the rayats, while the other was taken charge of by the village munsif. The large specimen weighs 11½ ounces, and the fragments weigh about 1 ounce and ½ ounce respectively."

THE sponge trade of the Bahama Islands forms the subject of an excellent report by the U.S. Consul at Nassau. The number of persons engaged in this industry in the Bahamas is from 5000 to 6000, all of whom, except the shipowners, brokers, and skippers are coloured people. The sponges are gathered by means of iron hooks attached to long poles. By using a water-glass the fisherman can readily discover the sponges at the bottom, and then with his pole and hook he will bring up those he may select as fit for his purpose, leaving the smaller ones untouched. Some sponges adhere firmly to the bed of the sea, while others—known as "rollers"—are not attached at all. About ten years ago an attempt was made to introduce dredges, but it seemed likely that they would ruin the beds, and a law was passed forbidding their use. The vessels are provided and

fitted out, as a rule, for a voyage of about six weeks, and generally from six to eight voyages are made in the year. It is difficult to estimate the average catch per trip, as the cargoes vary greatly in size and value. Of the larger sponges a catch of 5000, or of the smaller ones 7500, would be considered a fair lot. Occasionally a cargo of from 12,000 to 15,000 large sponges has been brought in, but this success is exceptional. Contradictory statements are made as to the time taken by sponges to grow to the size at which they are wanted. It seems probable, however, that under ordinary conditions a healthy sponge will reach a marketable size in from twelve to eighteen months.

EXTENSIVE excavations of the prehistoric mounds in Ohio and Indiana have lately been carried on under the supervision of Prof. Putnam. In one mound, near Anderson Station, Indiana, 7232 flint spear-heads and knives have been discovered. They were found in a layer one foot thick, extending over a space of twenty by thirty feet. They are made of grey flint found only in Indiana. The largest find of flint implements previously made in America did not include more than 1800 specimens.

STATISTICS published by the French Ministry of Public Instruction show that there are in France 525 learned Societies, of which 135 have been officially recognized as of national importance. Of these 525 Societies, 95 are historical and social; 95 agricultural and horticultural; 57 medical and pharmaceutical; 45 scientific; 41 artistic; 37 geographical; and the rest miscellaneous, including photographic, statistical, and ballooning associations.

PROF. KIKUCHI, of Tokyo, whose Japanese treatise on geometry we noticed briefly a year or two since, has now published a translation of his work into English. In the first Japanese Parliament Prof. Kikuchi had the honour to be made a life member of the House of Peers by the Emperor ("this does not constitute peerage as in England"), and at the request of the Department of Agriculture and Commerce he was one of the original framers of the Weights and Measures Bill.

THE Cambridge University Press has published a second edition of Mr. S. L. Loney's "Treatise on Elementary Dynamics." The book is intended for beginners, the author having dealt only with those parts of dynamics which can be treated without the use of the infinitesimal calculus. In the present edition the work has been carefully revised and somewhat enlarged.

THE first part has now been issued of the *Zeitschrift für Pflanzenkrankheiten*, edited by Dr. Paul Sorauer, with the assistance of an "International Phytopathological Committee." The journal is intended to be published bi-monthly, at a subscription of 15 marks per annum; and will contain original articles, reviews, and news, extending over the whole subject of the diseases of plants and the remedies for these diseases.

MESSRS. CASSELL AND CO. have issued Part 37 of their "New Popular Educator." Besides many illustrations in the text, there is a coloured plate representing sea-jellies and sea-stars.

FREE hydroxylamine,  $\text{NH}_2\text{OH}$ , has been isolated by M. Lobry de Bruyn, and a preliminary account of its mode of preparation and properties is published by him in the current number of the *Recueil des travaux chimiques des Pays-Bas* (1891, 10, 101). The manner in which the free base was obtained was briefly as follows. About a hundred grams of hydroxylamine hydrochloride,  $\text{NH}_2\text{OH} \cdot \text{HCl}$ , were dissolved in six hundred cubic centimetres of warm methyl alcohol. To this solution a quantity of sodium dissolved in methyl alcohol was added, in such proportion that the hydrochloride of hydroxylamine was present in slight excess over and above that required to convert it to sodium chloride. After deposition of the separated sodium

chloride the solution was decanted and filtered. The greater portion of the methyl alcohol was next removed by distillation under the reduced pressure of 160–200 mm. The remainder was then treated with anhydrous ether, in order to completely precipitate the last traces of dissolved sodium chloride. The liquid eventually separated into two layers, an upper ethereal layer containing about 5 per cent. of hydroxylamine, and a lower layer containing over 50 per cent. of hydroxylamine, the remainder of the methyl alcohol, and a little dissolved salt. By subjecting this lower layer to fractional distillation under 60 mm. pressure, it was separated into three fractions, of which the first contained 27 per cent. of hydroxylamine, the second 60 per cent., and the third crystallized in the ice-cooled receiver in long needles. This third fraction consisted of free solid  $\text{NH}_4\text{OH}$ . Hydroxylamine as thus isolated in the free state is a very hygroscopic substance, which rapidly liquefies when exposed to air, owing to the absorption of water. The crystals melt at  $33^\circ$ , and the fused substance appears to possess the capability of readily dissolving metallic salts. Sodium chloride is very largely soluble in the liquid; powdered nitre melts at once in contact with it, and the two liquids then mix. Free hydroxylamine is without odour. It is heavier than water. When rapidly heated upon platinum foil it suddenly decomposes in a most violent manner, with production of a large sheet of bright-yellow flame. It is only very slightly soluble in liquid carbon compounds such as chloroform, benzene, ether, acetic ether, and carbon bisulphide. The vapour attacks corks, so that the solid requires to be preserved in glass-stoppered bottles. The free base appears also to act upon cellulose, for, upon placing a few drops of the melted substance upon filter paper, a considerable amount of heat is evolved. The pure crystals are very stable, the base in the free state appearing to possess much greater stability than when dissolved in water. The instability of the solution appears, however, to be influenced to a considerable extent by the alkalinity of the glass of the containing vessel, for concentrated solutions free from dissolved alkali are found to be perfectly stable. Bromine and iodine react in a remarkable manner with free hydroxylamine. Crystals of iodine dissolve instantly in contact with it, with evolution of a gas and considerable rise of temperature. Bromine reacts with violence, a gas again being explosively evolved and hydrobromic acid formed. The nature of the gas evolved is now undergoing investigation. A letter from M. Lobry de Bruyn appears in the number of the *Chemiker Zeitung* for October 31, warning those who may attempt to prepare free hydroxylamine by the above method that it is a dangerously explosive substance when warmed to a temperature of  $80^\circ$ – $100^\circ$ . Upon warming a flask containing the free solid base upon a water-bath a most violent explosion occurs. A spontaneous decomposition appears to set in about  $80^\circ$ , and even in open vessels the explosion is very violent. Care must also be taken during the fractional distillation of the concentrated solution in methyl alcohol to cool the apparatus before changing the receiver, as if air is admitted while the retort is heated the experiment ends with an explosion.

The additions to the Zoological Society's Gardens during the past week include a Rhesus Monkey (*Macacus rhesus* ♀), two Macaque Monkeys (*Macacus cynomolgus* ♂ ♀), a Bonnet Monkey (*Macacus sinicus* ♀) from India, two Roseate Cockatoos (*Cacatua roseicapilla*), a Greater Sulphur-crested Cockatoo (*Cacatua galerita*), two Cockateels (*Calopsitta nova-hollandica*) from Australia, presented by the Rev. Sidney Vatcher; two Rhesus Monkeys (*Macacus rhesus* ♂ ♂) from India, presented by Mr. John H. Taylor; a Macaque Monkey *Macacus cynomolgus* ♂ from India, presented by Mr. K. A. Williams; a Yak (*Poephagus grunniens* ♂) from Tibet, presented by Mr. M. E. C. Ingram; a Corn Crane (*Crex pratensis*), British, presented by Mr. E. Hart, F.Z.S.; two Woodcocks (*Scolopax rusticola*,

British, presented respectively by Mr. Hamon Le Strange, F.Z.S., and Mr. William Bellamy; two Water Vipers (*Conechris piscivorus*), a Water Rattlesnake (*Crotalus adamantens*) from Florida, presented by the Natural History Society of Toronto; a Small-scaled Mastigure (*Uromastix microlepis*) from Persia, presented by Mrs. Howell; an Alligator (*Alligator mississippiensis*) from the Mississippi, presented by Mr. W. Chattaway; two Bearded Vultures (*Gypaetus barbatus*), European, deposited; a Molucca Deer (*Cervus moluccensis*), born in the Gardens.

OUR ASTRONOMICAL COLUMN.

THE TELLURIC SPECTRUM.—Dr. Müller has made some observations of the telluric spectrum on the summit of the Sântis, and his results are given in a recent publication of Potsdam Observatory (vol. viii., No. 27). The observing station was situated at a height of 2500 metres above sea-level. It was found that when the sun had a mean altitude, about 40 per cent. of the lines due to the water vapour in the atmosphere were quite invisible, and the remainder were very weak. Whilst the zenith distance of the sun was less than  $60^\circ$ , the appearance of the spectrum remained unchanged. At greater zenith distances the weak lines increased in intensity and the missing ones gradually appeared. Measurements of the intensities of single lines observed on different days and at different zenith distances indicate a variation roughly proportional to the thickness of atmosphere traversed. The aspect of the portion of spectrum observed was on the whole strikingly similar to that seen when observations were made near sea-level on dry and cold days. This is in agreement with the fact that the vapour pressure on mountains in summer is approximately equal to that on the plains in winter. Careful estimations of the intensities of the atmospheric lines at C and D might therefore be utilized to determine the decrease of the amount of vapour present in the air at different elevations. With regard to other atmospheric lines, Dr. Müller observed changes in the  $\alpha$ -group. The whole of the lines of this group, however, were easily seen at the mountain station when the sun had a high altitude, and the difference of intensity there and in the plains was considerably less than in the groups C and D. Two maps are given illustrating the appearance of the lines in the neighbourhood of C and D for different zenith distances of the sun.

TEMPEL-SWIFT'S PERIODIC COMET.—The following ephemeris is given by M. Bossert in *Astronomische Nachrichten*, No. 3063:—

1891.	Ephemeris for Paris Midnight. °			Brightness.
	Right Ascension.	Declination.		
	h. m. s.			
Nov. 3	21 31 22	+ 7 49.6	10.1	
" 5	21 37 6	8 37.5		
" 7	21 43 17	9 27.7		
" 9	21 49 59	10 19.3		
" 11	21 57 13	11 15.1	11.9	
" 13	22 4 59	12 12.1		
" 15	22 13 19	13 11.2		
" 17	22 22 14	14 12.0		
" 19	22 31 45	15 14.4	13.5	
" 21	22 41 54	16 18.0		
" 23	22 52 41	17 22.2		
" 25	23 4 6	18 26.6		
" 27	23 16 9	19 30.5	14.4	
" 29	23 28 48	20 33.2		
Dec. 1	23 42 1	21 33.9		
" 3	23 55 46	22 31.8		
" 5	0 9 57	23 26.2	14.0	
" 7	0 24 30	24 16.3		
" 9	0 39 18	25 1.4		
" 11	0 54 15	25 41.0		
" 13	1 9 13	26 14.9	12.0	

The comet is moving north at the rate of  $1^\circ$  per day. It will be in Pegasus all this month, and will pass about  $4^\circ$  north of a Pegasus (Marcab) near the 23rd inst. The maximum brightness is reached at the end of the month.

CATALOGUE OF RUTHERFURD'S PHOTOGRAPHS.—A year ago Dr. Lewis Rutherford presented to the Observatory of Columbia College all his photographic negatives taken between

the years 1858 and 1878, and thirty quarto volumes containing the measures of many of them. The *Annals of the New York Academy of Sciences*, vol. vi., June 1891, contains a catalogue of these negatives. There are 139 negatives of the sun taken between 1860 and 1874, each of which has the time of exposure marked upon it. Several negatives were taken of the eclipses of 1860, 1865, and 1869. The solar spectrum is the subject of 160 negatives and 14 positives. The list of lunar negatives numbers 408, 40 of which are covered for protection. Mars was photographed in 1877, and the transit of Mercury in the following year. It is hoped soon to issue reductions of the measures of the numerous negatives of stars and clusters.

#### THE INSTITUTION OF MECHANICAL ENGINEERS.

A GENERAL meeting of the Institution of Mechanical Engineers was held on Wednesday and Thursday evenings of last week, the 28th and 29th ultimo. The meeting took place at the Institution of Civil Engineers, Great George Street, the theatre having been lent by the Council of the latter Society for the purpose. The President, Mr. Joseph Tomlinson, occupied the chair, and there were two papers on the agenda. The first of these, taken at the Wednesday's sitting, was "On some Details in the Construction of Modern Lancashire Boilers," by Mr. Samuel Boswell, of Manchester. The evening of Thursday was occupied with the reading of "The Report to the Alloys Research Committee," made by Prof. W. C. Roberts-Austen, C.B., F.R.S.

The first paper does not call for much attention at our hands. It dealt exclusively with boiler-making practice, and can hardly be of much interest outside the boiler-shop and draughting office. Within these limits the paper is one of great value, and therefore will occupy a most fitting place in the Proceedings of the Institution. The contribution of Prof. Roberts-Austen was of a very different description; and although it may not appeal so directly to the majority of mechanical engineers, it can hardly fail to improve the practice of engine construction, and advance the science of the production of mechanical energy many steps nearer that ideal of efficiency which is the goal all good engineers should keep in view. We have on previous occasions dwelt upon the excellent work done by the various Research Committees appointed by the Council of this Institution, and we can think of no better way in which the surplus funds of the Institution could be spent. Of all these Research Committees, it may be said that that appointed to consider the question of alloys is the most comprehensive and important, for we appear to be fast coming to a period when engines will consist almost wholly of two alloys—namely, brass and steel. Cast-iron will naturally continue to be used for massive parts where comparatively great weight is of small importance, but wrought-iron is every day giving place to steel, and steel castings have already almost entirely superseded those of iron in positions where it is desirable to combine lightness and strength.

Prof. Roberts-Austen's report is a long document occupying twenty-four pages of the Proceedings, and illustrated by several diagrams. We shall therefore, with the space at our command, be able to do little more than give an outline of its scope, or at any rate we can do no more than dwell on a few of the more salient features. In dealing with the question of iron and its alloys, the author assumed the reader to have an acquaintance with the work of the talented French physicist Osmond, of whom, as is well known, Roberts-Austen is a great admirer. Osmond holds that the results of his experiments show that there are two distinct varieties of pure iron—namely, the  $\alpha$  or soft form, and the  $\beta$  or hard form. M. Osmond, it will be remembered, set forth his views in a paper read at the meeting of the Iron and Steel Institute, held in 1890.<sup>1</sup> Mr. Roberts-Austen had previously commenced an investigation upon the application of the "periodic law" of Newlands and Mendeleeff to the mechanical properties of metals, and the Research Committee requested him to carry his work in this direction still further. This law, as originally expressed, states that "the properties of the elements are a periodic function of their atomic weights." It has been shown that the effect of impurities added to gold is nearly proportional to their atomic volume, the larger the volume of the atom the greater being its effect.<sup>2</sup> It became

interesting to determine, therefore, whether this holds good for other metals. Osmond had determined that the action of impurities on iron does appear to be in accordance with the periodic law; and he had arranged the elements in the following order in accordance with their atomic volumes, found by dividing their atomic weight by their specific gravity:—

I.		II.	
Carbon	3.6	Chromium	7.7
Boron	4.1	Tungsten	9.6
Nickel	6.7	Silicon	11.2
Manganese	6.9	Arsenic	13.2
Copper	7.1	Phosphorus	13.5
		Sulphur	13.7

Osmond pointed out that the elements in column I., whose atomic volumes are smaller than that of iron (7.2), delay during cooling, *ceteris paribus*, the change of hard iron into soft iron, as well as that of "hardening carbon" into "carbide carbon." For these two reasons they tend to increase, with equal rates of cooling, the proportion of hard iron that is present in the cooled iron or steel, and consequently the hardness of the metal. The elements in column II. tend to raise, or maintain at its normal position during cooling, the temperature at which the change of hard to soft iron takes place. Further, they render the inverse change during heating more or less incomplete, and usually hasten the change of dissolved or hardening carbon to carbide carbon. Thus they maintain iron in the soft state at high temperatures, and must therefore have the same effect in the cooled metal. In this way they would act on iron as annealing does, rendering it soft and malleable, did not their individual properties, or those of their compounds, mask this natural consequence of their presence. The essential part played by foreign elements alloyed with iron is therefore either to hasten or to delay the passage of iron during cooling to an allotropic state; and to render the change more or less incomplete in one direction or the other, according to whether the atomic volume of the added impurity is greater or less than that of iron. In other words, foreign elements of low atomic volume tend to make iron itself assume or retain the particular molecular form which possesses the lowest atomic volume; whilst elements with large atomic volume produce a reverse effect. The report goes on to point out that the effect of impurities on iron is far more complicated than in the case of gold; the latter being probably more simple in its molecular structure. Also if iron, by itself, can exist in two widely different states, the mechanical properties will be affected by the proportion of each. Lead also, which was one of the metals the Committee selected for investigation, probably exists in more than one modification. The author had made many experiments on the mechanical properties of lead as affected by a small quantity of impurity, but had not brought the results to any concordant or definite conclusion, and the inquiry was laid aside for a time. The fundamental necessity in carrying out the work of the Committee was a trustworthy pyrometer which would measure higher temperatures, and fortunately an instrument which appears to fulfil these conditions is now to be procured. This, we need hardly say, is the Le Chatelier pyrometer. This instrument consists of a thermo-couple of platinum and platinum-rhodium wire, the record being obtained by the measurement of the electric current produced. An autographic record is obtained by means of a spot of light thrown from a mirror attached to the galvanometer which measures the current. This spot of light is thrown on to a sensitized plate (Eastman's film) which is caused to travel by suitable means so as to give the time factor. The amplitude of the deflection naturally gives the temperature of the substance which is supplying the heat to the thermo-couple. The calibration has been carefully effected by observations at known temperatures; and the instrument has been tested by observations in connection with the liquation of silver-copper alloys, about which a good deal is known.

The report next proceeds to deal with the effect of small quantities of impurity on the freezing point of gold—a metal which offers special advantages for investigations of this nature, as it may be prepared in a very high degree of purity, and is not liable to contamination by oxidation. Moreover, much is already known of its mechanical and thermal properties as influenced by small quantities of impurity. The effects of certain alloys upon gold are given in the report, and are well worth study on the part of those inquirers who wish to prepare them-

<sup>1</sup> See also *Comptes rendus*, vol. cx., 1890, p. 346.

<sup>2</sup> Philosophical Transactions of the Royal Society, vol. clxix., 1888,



selves for a better understanding of the alloys of metals which come within the scope of every-day experience.

From the engineer's point of view, as the report states, the most interesting information which the pyrometer has yet afforded is connected with the measurement of the internal stresses in iron and steel. The molecular change which takes place in steel must be of vital importance when the metal is subjected at high temperature to mechanical operations such as rolling or forging. "Do the molecular changes in the iron take place at one moment throughout the mass of metal? that is, is the rate of cooling approximate throughout the mass, or does the external portion of the ingot cool so much more rapidly than the centre as to allow the molecular changes in the iron, and the relation between the carbon and the iron, to become completed near the surface long before they take place in the interior of the mass?" The pyrometer used allows some insight to be gained into this hitherto unassailable problem. A small ingot of mild steel had two holes drilled into it, one near the circumference, and the other at the centre. The ingot was heated, and a thermo-junction was inserted in each hole. In this way curves of temperature were obtained simultaneously. With the mild steel the evidence as to molecular change was but slight. Another ingot of steel, containing 0.799 per cent. of carbon, 0.084 per cent. of silicon, and 0.412 per cent. of manganese, was tried in the same way. The initial temperature at the centre was 1160° C. The curve showed the molecular change at 880° C., and the carbon change at 696° C. At the circumference the carbon change took place no less than four minutes earlier than at the centre, and at the lower temperature of 665° C. This is a most important point, as the rate of cooling, as Osmond has pointed out, has a measurable effect upon the temperatures at which molecular change occurs. The great internal strain which must be set up is evident when it is borne in mind that the carbon change is accompanied by a considerable alteration of volume. It is pointed out in the report that "there can be but little question that such experiments well deserve careful attention, and, in the hands of competent observers, should be fruitful of results."

On the conclusion of the reading of the paper, the President called for a discussion, when Dr. Anderson was the first to rise. He spoke in terms of warm praise as to the value of the work done by Prof. Roberts-Austen. As an instance, he mentioned that the method described in the report, by which the temperatures of an ingot could be obtained simultaneously at the centre and the circumference, would be of the greatest use in dealing with the large pieces of steel used for gun-hoops; and he expected great help from this in the work at the Royal Arsenal.

Mr. R. Hadfield, of Sheffield, followed. He gave a summary of the effect of the most prominent alloys of iron. This table will form a useful appendix to the report when published in the Transactions of the Institution.

Prof. Howe, of Boston, gave an instance in which the Le Chatelier pyrometer had been turned to good practical account. This was in the Rodman system of gun-casting. In that process it was most desirable to know the varying temperatures of different parts of the cast, but naturally this had been hitherto impossible. By inserting a thermo-couple in the mould it was possible to get this information at all times. He thought the Le Chatelier pyrometer the greatest boon that metallurgists had received for very many years.

The next speaker was Prof. Arnold, of Sheffield, who made a certainly vigorous speech. We think, however, that he was rather carried away by his enthusiasm. To say that the work done by the author of the report was "not worth a rush," is rather straining the prerogative of rhetoric; and we failed to see, when Prof. Arnold descended to facts, that he justified the florid language of his exordium. Prof. Roberts-Austen, in his reply, gave an example of forbearance and good temper which it would be well if men of science could often follow. It was satisfactory to notice that the feeling of the meeting was by no means in accordance with Prof. Arnold.

Mr. Stromeyer added to the work done a useful table in which were collated the opinions of various authorities on the effect of alloys upon iron. The table was not read, but will be published in the Proceedings. Such work as this is very acceptable. It involves a great deal of labour and brings but small return in the way of praise and glory, which of course are two things to which a true follower of science is profoundly indifferent.

Mr. Stead, of Middlesborough, protested against Prof. Arnold's remarks, and spoke of the value of the author's work. The testimony of Mr. Stead is valuable, as he combines the position of a practical investigator, working for commercial ends, and a man of science.

The meeting broke up after passing the usual votes of thanks.

### UNIVERSITY AND EDUCATIONAL INTELLIGENCE.

OXFORD.—The Junior Scientific Club held their first meeting this term in the Physiological Laboratory at the Museum, under the presidency of Mr. R. S. Gunther, of Magdalen.

Mr. W. Pullinger, of Balliol, read a paper on volatile platinum compounds, and exhibited prepared specimens.

Mr. A. F. S. Kent, of Magdalen, indicated improvements in the manipulation of photo-micrography whereby the effect of tremors was excluded, and passed through the lantern some very excellent slides which he had taken from negatives obtained by his new method.

Mr. G. E. C. Pritchard, of Hertford, exhibited specimens of Bacteria, and described the method whereby they had been obtained and prepared for microscopic exhibition.

Dr. Collier read a paper of a very interesting character on the physiology of muscular exercise with special reference to training, in the course of which he traversed some statements recently made by Sir Morell Mackenzie, to the effect that fatigue was due to the cessation of blood flowing to the muscles. Dr. Collier would rather attribute fatigue to the development of waste-products in the muscle, formed too rapidly for the blood to remove them, and quoted experiments carried out on frogs which seemed to support this view.

CAMBRIDGE.—The Agricultural Education Syndicate, in view of a grant of £400 a year from the Cambridgeshire County Council, recommend that a lecturer in agricultural science, who shall also be director of agricultural studies, should be appointed at a stipend of £500. They also propose that a second lecturer be appointed at a stipend of £300. These two lecturers would take between them the subjects of agricultural botany and agricultural chemistry.

The degree of M.A. *honoris causa* has been conferred on the distinguished entomologist Mr. D. Sharp, F.R.S., Curator in Zoology at the University Museums.

Dr. Sir A. Geikie and Dr. T. G. Bonney have been appointed adjudicators of the Sedgwick Prize of 1895.

At St. John's College, on November 2, the following were elected to the vacant Fellowships: William McFadden Orr, B.A., Senior Wrangler, 1888; Edward Ernest Sikes, B.A., First Class (Division 1), Classical Tripos, 1889, Newton Student in Archæology; Percival Horton-Smith, B.A., First Class Natural Sciences Tripos, 1889-90 (distinguished in physiology), late Hutchinson Student in Physiology.

### SOCIETIES AND ACADEMIES.

#### PARIS.

Academy of Sciences, October 26.—M. Duchartre in the chair.—On the theory of Hertz-oscillations, by M. H. Poincaré.—On a new mineral—boleite, by MM. Mallard and E. Cumenge. The new mineral occurs with copper in volcanic tuff and conglomerate found near Santa Rosalia, Lower California. It crystallizes in the cubic system, and its composition is represented by the expression  $PbCl_2 + CuO.H_2O + \frac{1}{2}AgCl$ . Its density is a little greater than that of calcite; cleavage easy parallel to the faces of cube, much less easy parallel to faces of octahedrons. Approximate index of refraction, 2.07.—Vasomotor action of bacteria, by M. Ch. Bouchard.—Contribution to the botanical history of the truffe (fourth note): *Kama* of Bagdad (*Terfezia Hafsa* and *Terfezia metaxasi*) and of Smyrna (*Terfezia Leonis*), by M. Ad. Chatin.—On a storm observed at the Canary Islands. This is an extract from a memoir by M. de la Monneraye.—On the original causes of cyclones, and on their precursor signs: extract from a memoir by M. Le Goarant de Tromelin.—On the theory of the voltaic pile, by M. P. Duhem.—Experimental researches on a category of capillary phenomena, with an application to the analysis of alcoholic liquids and others, by M. Emile Gossart.—On bromo-

stannates, by M. Leteur. The author has prepared the following bromostannates, the general method consisting in mixing concentrated solutions of the two bromides, and evaporating the mixture in a vacuum or dry air:  $\text{SnBr}_4 \cdot \text{NH}_4\text{Br}$ ,  $\text{SnBr}_4 \cdot \text{NaBr} + 6\text{H}_2\text{O}$ ,  $\text{MgBr}_2 \cdot \text{SnBr}_4 + 10\text{H}_2\text{O}$ .—On a new crystalline ferric oxychloride, by M. G. Rousseau. Concentrated solutions containing more than 80 per cent. of  $\text{Fe}_2\text{Cl}_6$ , if kept for some time at a temperature between  $160^\circ$  and  $220^\circ \text{C}$ ., give rise to crystalline ferric oxychloride,  $2\text{Fe}_2\text{O}_3 \cdot \text{Fe}_2\text{Cl}_6 \cdot 3\text{H}_2\text{O}$ . The author has studied the decomposition of solutions of ferric chloride at temperatures higher than  $220^\circ$ . Between  $225^\circ$  and  $280^\circ$  anhydrous oxychloride ( $2\text{Fe}_2\text{O}_3 \cdot \text{Fe}_2\text{Cl}_6$ ) was obtained. At temperatures between  $300^\circ$  and  $340^\circ$  a new oxychloride was formed, having the composition  $3\text{Fe}_2\text{O}_3 \cdot \text{Fe}_2\text{Cl}_6$ .—On the estimation of thallium, by M. H. Baubigny.—On the solution of bismuth chloride in saturated solutions of sodium chloride, and on the basic salicylate of bismuth, by M. H. Causse.—On a characteristic difference between the alcoholic radicles substituted in place of carbon and nitrogen, by M. C. Matignon. From a thermo-chemical investigation the author finds that the substitution of an alcoholic radicle for nitrogen increases the heat of combustion more than the substitution of the same radicle for carbon.—Action of benzoic acid on essence of turpentine, by MM. G. Bouchardat and J. Lafont.—On the formation of quaternary iodides of ammonium by the action of trimethylamine, in concentrated aqueous solutions, or the hydriodic ethers of several primary and one secondary alcohol, by MM. H. and A. Malbot.—On a new albuminoid substance in the blood serum of man, by M. C. Chabrié.—The soluble substances of the pyocyanic bacillus producing fever, by M. A. Charrin.—Experimental progressive muscular atrophy, by M. Roger.—Some anatomical characteristics of *Hyperoodon rostratus*, by M. E. L. Bouvier.—*Appropos* the chromatophores of Cephalopods, by M. Raphael Blanchard.—Physiology of the nerve which enables us to localize sounds, by M. Pierre Bonnier.—On a method for destroying insects injurious to the beetroot and cereals, by M. Decaux.

DIARY OF SOCIETIES.

LONDON.

THURSDAY, NOVEMBER 5.

LINNEAN SOCIETY, at 8.—A Theory of Heredity based on Force instead of Matter: Rev. Prof. Henslow.  
 CHEMICAL SOCIETY, at 8.—The Dissociation of Liquid Nitrogen Peroxide: J. Tudor Cundall.—The Magnetic Rotation of the Ammonium and Sodium Salts of Fatty Acids: Dr. Perkin, F.R.S.—The Vapour-Pressures and Molecular Volumes of Acetic Acid and of Carbon and Tin Tetrachlorides: Prof. S. Young.—The Ortho- and Para-nitro Derivatives of Orthotolidine: A. G. Green and P. A. Lawson.—Researches on the Gums of Arabian Gum, Part II.: C. O'Sullivan, F.R.S.  
 CAMERA CLUB, at 8.30.—The Action of Light and Heat upon the Haloid Silver Salts: Dr. J. J. Acworth.

FRIDAY, NOVEMBER 6.

PHYSICAL SOCIETY, at 5.—On Corresponding Temperatures, Pressures, and Volumes: Prof. Sydney Young.  
 GEOLOGISTS' ASSOCIATION, at 8.—*Conversazione*.

SATURDAY, NOVEMBER 7.

ESSEX FIELD CLUB, at 7.—Notes concerning the Distribution of Mollusca in the Thames Estuary: A. J. Jenkins.—Some Remarks upon the Aquatic Plants and Algae of the Thames Marshes: A. J. Jenkins.—On the Occurrence of Westleton Beds in part of North-Western Essex: J. French.

SUNDAY, NOVEMBER 8.

SUNDAY LECTURE SOCIETY, at 4.—The Personal Life of Shakespeare: W. E. Church.

MONDAY, NOVEMBER 9.

CAMERA CLUB, at 8.30.—Lenses, II.: Lyonel Clark.

TUESDAY, NOVEMBER 10.

MINERALOGICAL SOCIETY, at 8.—Anniversary Meeting.  
 INSTITUTION OF CIVIL ENGINEERS, at 8.—President's Address: George Berkley.—Presentation of Medals, Premiums, and Prizes.  
 PHOTOGRAPHIC SOCIETY, at 8.

WEDNESDAY, NOVEMBER 11.

GEOLOGICAL SOCIETY, at 8.—On Dacrythium ovium from the Isle of Wight and Jersey: R. Lydekker.—Supplementary Remarks on Glen Roy: Thos. F. Jamieson.

THURSDAY, NOVEMBER 12.

MATHEMATICAL SOCIETY, at 8.—On the Classification of Binodal Quartic Curves: H. M. Jeffery, F.R.S.—On Selective and Metallic Reflection: A. B. Basset, F.R.S.—On a Class of Automorphic Functions: Prof. W. Burnside.—The Contacts of Systems of Circles: A. Larmor.—Note on the

Identity  $4(x^2 - 1)(x - 1) = Y^2 + AZ^2$ : Prof. G. E. Mathews.—Note on Finding the G Points of a given Circle with respect to a given Triangle: Reference: J. Griffiths.

INSTITUTION OF ELECTRICAL ENGINEERS, at 8.—Description of the Standard Volt and Ampere Meter used at the Ferry Works, Thames Ditton: Captain H. R. Sankey (at R.E.) and F. V. Andersen.  
 CAMERA CLUB, at 8.30.—A New Method of Photography by Artificial Light: E. J. Humphrey.

FRIDAY, NOVEMBER 13.

ROYAL ASTRONOMICAL SOCIETY, at 8.  
 INSTITUTION OF CIVIL ENGINEERS, at 9.30.—Description of the Works on the Barking and Pitsea Extension Railway: Henry E. Stilgoe.—Rail File Bridges in Ceylon: Harry Bucknall.  
 CAMERA CLUB, at 8.—Retouching: Redmond Barrett.

SATURDAY, NOVEMBER 14.

ROYAL BOTANICAL SOCIETY, at 3.45.

BOOKS, PAMPHLETS, and SERIALS RECEIVED.

Natural Theology: Sir G. G. Stokes (Black).—Elementary Trigonometry: J. M. Dyer and Rev. R. H. Whitcombe (Bell).—Fundamental Problems: Dr. P. Carus, 2nd edition (Chicago).—L'Amateur d'Oiseaux de Volière: H. Moreau (Paris, Baillière).—Les Coquilles Marines: A. Locard (Paris, Bailière).—Colour-Blindness and Colour-Perception: Dr. F. W. Eddridge-Green (Paul).—Handleiding tot de Kennis der Flora van Nederlandsch Indië: Dr. J. G. Boerlage, Tweede Deel, Eerste Stuk (Leiden, Brill).—Star Groups: J. E. Gore (Lockwood).—Elementary Thermodynamics: J. Parker (Cambridge University Press).—Report on the Meteorology of India in 1889: J. Eliot (Calcutta).—Copernic et la Découverte du Système du Monde: C. Flammarion (Paris, Marpon and Flammarion).—Moral Teachings of Science: A. B. Buckley (Stanford).—Further Reliques of Constance Naden: edited by G. M. McCrie (Bickers).—The Wire and the Wave: J. Mauro (R.I.S.).—Vittorligare om Gadolinit-Jordens Molekylvägigt: A. E. Nordenskiöld (Stockholm).—Notes on the Recent Geometry of the Triangle: J. Griffiths (Simpkin).—Journal of the Royal Microscopical Society, October (Williams and Norgate).—Illustrations of the Flora of Japan, vol. 1. Nos. 7, 8, 9 (Tokyo).

CONTENTS.

PAGE

Electricity and Magnetism. By Prof. A. Gray . . .	1
Biology of Seaside Plants. By W. Botting Hemslley, F.R.S. . . . .	3
Ricardo's "Political Economy." By W. E. J. . . . .	4
Our Book Shelf:—	
Schnauss: "Photographic Pastimes: a Hand-book for Amateurs" . . . . .	5
"On Surrey Hills" . . . . .	5
Munro: "Heroes of the Telegraph" . . . . .	5
Letters to the Editor:—	
The Koh-i-Nur. (Illustrated).—Prof. N. Story Maskelyne, F.R.S. . . . .	5
A Rare Phenomenon.—Dr. M. A. Zeeder, Prof. J. R. MacGregor; and R. H. Hudspeth . . . . .	7
Apparent Size of Objects near the Horizon.—T. W. Backhouse . . . . .	7
Proper Motions of the Stars.—W. H. S. Monck . . . . .	8
California Foxes.—Prof. Edward S. Holden . . . . .	8
A Plague of Small Frogs.—R. Haig Thomas . . . . .	8
Botany of the Emin Relief Expedition. By W. T. Thielston Dyer, C.M.G., F.R.S.; Major I. A. M. Jephson . . . . .	8
Town Fogs and their Effects. (Illustrated.) By Dr. W. J. Russell, F.R.S.; W. Watson . . . . .	10
The Anatomy of the Dog. (Illustrated.) . . . .	16
Notes . . . . .	18
Our Astronomical Column:—	
The Telluric Spectrum . . . . .	21
Tempel-Swift's Periodic Comet . . . . .	21
Catalogue of Rutherford's Photographs . . . . .	21
The Institution of Mechanical Engineers . . . . .	22
University and Educational Intelligence . . . . .	23
Societies and Academies . . . . .	23
Diary of Societies . . . . .	24
Books, Pamphlets, and Serials Received . . . . .	24

THURSDAY, NOVEMBER 12, 1891.

## THE HYGIENE OF WATER-SUPPLY.

*An Elementary Hand-book on Potable Water.* By Floyd Davis, M.Sc., Ph.D. (Boston, U.S.: Silver, Burdett, and Co., 1891.)

THE aphorism that "history repeats itself" is being very strikingly illustrated in the matter of hygiene at the present day. Questions respecting water-supply and the public health generally, which in this country were absorbing much of scientific attention some fifteen or twenty years ago, have only within the last decade begun to be seriously dealt with even in the most civilized of Continental countries and in the United States. Indeed, although we are indebted for much of the recent progress which has been made in what may be called the theory of hygiene to our Continental neighbours, yet in matters of actual practice we still hold, undisputedly, the first place among nations. The practice of hygienic principles cannot be introduced by Act of Parliament or Imperial ukase; it is the growth of years, or rather generations, and is quite independent of the establishment of hygienic institutes and bacteriological laboratories. In a few hours of Continental travel, it is possible to visit University towns provided with hygienic laboratories, munificently equipped, in which food-stuffs are daily submitted to elaborate analysis, whilst water and milk are searchingly interrogated as to the micro-organisms which they contain; and yet side by side with these refinements we find sanitary conditions, even in the houses of the well-to-do, which would hardly be found in the alleys and purlieus of one of our manufacturing centres. It is far from my wish or purpose to deprecate the establishment of institutions for the prosecution of hygienic inquiries on a scientific basis; on the contrary, such places are calculated to enormously accelerate the achievement of sanitary improvements, and to economize time, money, and human life, which are ruthlessly wasted when these improvements are attained as the result of empiricism and the operation of natural forces. Our position of supremacy in practical sanitation is mainly due to the long period of domestic repose and prosperity which we have enjoyed, and which has led us to turn our attention to the prevention of the unnecessary sacrifice of human beings even in civil life; but who can doubt that this position would have been much more rapidly gained if these endeavours had been always guided by scientific knowledge and systematic experimental inquiry? Even as it is, the path to our present position has been much shortened, and has been rendered less costly both as regards life and money, by the time and attention which have been bestowed upon sanitary matters by men of high scientific attainments. It is earnestly to be hoped that the recent Hygienic Congress held in our midst will have convinced those who control the purse of this country that a national effort must be made to maintain our position in the scientific as well as the practical progress of the century. We have not to

deprecate any shortcoming in the quality of the scientific work which emanates from us; in originality and as pioneers in all departments of science we are second to none; but quantitatively we are lamentably deficient, and in consequence, it is only too frequently the case that we have to leave to others the cultivation of those fields which we have ourselves had a large share in discovering. This is most conspicuously the case in the matter of hygiene; and after the highly discreditable obstruction, with which the foundation of our National Institute of Preventive Medicine was recently harassed, has now happily been swept away, we trust that public if not Government support will be forthcoming in the immediate future, to render that Institution, with its tremendous potentiality for benefiting mankind, second in usefulness and dignity to none in the civilized world. The State organization of science in the New World has made great strides during recent years, and scientific men in this country cannot fail to be impressed with the immense volume of work—more especially in applied science—which annually flows from the laboratories of the United States. The appearance of the book before us is, presumably, evidence of this great activity, showing as it does that there is a considerable body of men anxious to have presented to them in a concise and handy form all the main facts which have been accumulated—and which are dispersed in innumerable reports, blue-books, journals, and other forms of literature—concerning potable water. The difficulty of access to the original sources of this information renders such a work of great importance at the present time, but one which it is extremely difficult to do justice to. The present volume, we regret, does not come up to what we could wish for in a work of the kind. The questions which have to be discussed are in many cases necessarily more or less matters of opinion, in which conflicting evidence ought to be balanced and submitted to careful and critical analysis; unfortunately, however, for the exercise of this judicial power the author exhibits but little aptitude or inclination. The pages are sometimes filled with authoritative statements made by their respective authors on insufficient data, which statements have been copied, often not even from the original sources, without a word of elucidation or criticism. Such material, placed in the hands of the unwary reader, may lead to very serious consequences. Of this character is the statement that "the power of certain samples of water to dissolve lead is directly proportional to the number of micro-organisms that the samples respectively contain," which might well have been omitted from this work; and its introduction as almost the only piece of information concerning the action of water on lead is singularly inappropriate. Again, on another page, we are categorically informed that "even milk is sometimes the agent of this disease (typhoid fever), in which case the typhoid poison remains undestroyed in passing from the polluted water from which the cows drink, to the milk-secreting glands"; whilst no mention is made of the real mode of transmission by the watering of milk and the rinsing of cans with contaminated water. In most cases the principles laid down are sound and reasonable; but the author has permitted himself to be carried some-

what too far in his advocacy of pure water, when he says that "scientific investigation also reveals the fact that, as a community is supplied with pure water, there is not only a decrease in the disease and death-rate, but often a most surprisingly rapid increase in thrift, morality, and degree of civilization." We should be glad indeed if he were correct in his statement that since the introduction of an efficient health administration in England, the prevalence of typhoid has been reduced to such an extent that "for weeks and even months not a single case now occurs in the city of London." We can readily understand that our rivers must appear insignificant enough to the inhabitants of a country containing such mighty streams as the St. Lawrence, the Mississippi, and the Ohio; and although we are fully alive to some of them being disgracefully fouled, we certainly are somewhat startled to have our watercourses, which are dear to many of us, disposed of in the following sentences:—"The pollution of English streams is carried to such an enormous extent that the waters of many, where city sewage enters them, are actually offensive, and during the summer months, owing to the stench, the passenger traffic is forced to the railroads. In some of these streams the whole surface of the water, for some distance below sewage entrance, is in a state of commotion, owing to the evolution of gas bubbles, and the water is so foul that it cannot be used in the boilers of the little steamers that ply across the rivers. Immediately below the entrance of sewage no life can exist in the water, on account of the presence of ferrous sulphate (*sic*), which is a disinfectant." In dealing with the much vexed subject of the apparent self-purification of streams, the author shows a very just appreciation of the matter when he points out that there "is no guarantee that running water is perfectly wholesome at any distance below a point where it is certainly polluted with the contents of sewers and privy-vaults, or the decomposition of vegetable and animal matter. The question as to what extent must impure water be diluted or oxidized to render it safe for domestic purposes, cannot be answered. Mere dilution of polluted water does not render inoperative the action of living bacteria. . . ." We are glad to see that the author points out the importance of boiling all drinking-water which is open to suspicion, for it cannot be too frequently reiterated that perhaps the two most effective measures which the private individual can take in avoiding zymotic disease consist in boiling the water and milk that are used for drinking. The largely increasing consumption of ice, which in America has assumed enormous proportions, is a matter which also calls for very careful attention, since recent experiments have shown that, although the living bacteria in ice are considerably less numerous than in the water from which the ice has been derived, still the process of freezing, even if long continued, affords no sort of guarantee that the dangerous forms originally present in the water shall have been destroyed. Thus the bacillus of typhoid fever has been found still alive in ice which had remained continuously frozen for a period of 103 days.

PERCY F. FRANKLAND.

#### CAUSATION OF SLEEP.

*The Intracranial Circulation and its Relation to the Physiology of the Brain.* By James Cappie, M.D. (Edinburgh: James Thin, 1890.)

THE factors concerned in the production of sleep have from time to time engaged the attention of physiologists, and various theories have been advanced to explain the phenomena. The author of the work now before us, so far back as 1854, published a short essay on "The Immediate Cause of Sleep," which he subsequently expanded into a volume entitled "The Causation of Sleep" (Edinburgh, 1882). In the work now under consideration, although with a different title, the author travels over much the same ground as that surveyed in his previous writings on this subject, and adds to it some additional chapters.

In his successive publications Dr. Cappie accepts the position usually taken up by physiologists, that the state of sleep is accompanied by a diminished brain circulation; but he combats the view that sleep is due to a diminution of the whole mass of blood within the cranial cavity, and that the compensation for this diminution is got by an increase in the amount of cerebro-spinal fluid in the ventricular and sub-arachnoid spaces of the brain. His objection to this opinion is based upon its not being reconcilable with either the physics or the physiology of the parts situated within the cranium. As regards the physics, he adopts the view advocated by Drs. Alexander Monro (*secundus*), Abercrombie, and Kellie, that, inasmuch as the brain lies within a closed cavity, which possesses rigid bony walls, the contents cannot be affected directly by the pressure of the atmosphere, which can only influence the interior of the cranium through the blood-vessels, so that a force is constantly in operation to maintain the amount of blood within the intracranial vessels. The author believes that the effect of the pressure on the blood-vessels, say of the neck and head, is opposed to the movement of the blood in the veins, and that the tendency of the pressure is to keep the blood within the veins which ramify in the vascular membrane enveloping the brain, called the pia mater. At the same time, however, the arterial stream drives the blood onwards into the capillaries and the veins, which tends to dilate the latter vessels, and, in conjunction with the backward pressure on the great veins, to retard the flow of blood through the veins of the pia mater, and consequently through the great venous sinuses of the head, into the jugular veins. In this way he infers that, whilst the brain itself becomes less vascular, the mass of blood within the cranial cavity continues the same, but its mode of distribution is altered: a less proportion is taken the arteries and capillaries, whilst an increase takes place in the contents of the veins of the pia mater.

The author acknowledges, in connection with the nutrition of the brain, that molecular actions of a subtle kind take place between the blood and blood-vessels and the nervous tissues, and that these are much less active during sleep than when awake. The lessened activity in the nutrition of the nerve protoplasm diminishes the activity of the capillary circulation. He regards, however, the change in the balance of the circulation

between the arteries and capillaries on the one hand, and the veins on the other, as the key-stone of the theory of the causation of sleep. The altered balance of the circulation occasions a change in the balance of active pressure, which is not so much within the brain substance as on the surface. It is less expansive and more compressing, and with this compression consciousness is suspended.

In proof of his theory, the author adduces observations made by Dr. Hughlings Jackson and himself on the retina—the blood-vessels of which are so intimately connected with those of the brain—both during sleep and in a state of coma, from which it would appear that in these conditions the retina was paler, its arteries smaller, but its veins were larger, more tortuous, and distended. In another case recorded by Dr. Kennedy, where a portion of the skull and dura mater had been removed, and the pia mater consequently exposed, it was noticed that the veins in the latter were during sleep congested and assumed a dark hue.

In a concluding chapter, entitled "Some Points in Mental Physiology," which was not contained in his previous work "On the Immediate Cause of Sleep," the author considers how far the peculiarities of the encephalic circulation may affect the functional activity of the different parts of the brain. Starting from the position that the brain is a composite organ, and that distinct portions are put into a state of functional activity in connection with the discharge of their respective duties, the question of balance of the circulation has again to be considered. For the part which is more immediately concerned in the production of the particular cerebral operation must become the seat of vascular excitement, and the amount of blood flowing through its vessels will be greater than that transmitted through the vessels of those other parts of the brain which are for the time being not so functionally active. Hence a certain tension of the area or centre which is actively working must arise, and the encephalic circulation is focussed in the direction of activity. The parts which surround the operating centre would act as a background of resistance, and would afford such support as will secure the immediate liberating action in the discharging centre.

The author applies his views on the encephalic circulation to the explanation of the phenomena of Hypnotism. The first incident in the hypnotic state is a steady prolonged effort of volition in which the attention is concentrated in a very restricted direction. The immediate consequence is fatigue of the nerve-centres concerned in keeping up the strain. Their molecular motions become enfeebled, the circulation through them is less active, and a condition approaching that of sleep is produced. If then, in the form of a "suggestion" from another, some stimulus calls into activity a part of the brain not fatigued in the effort of attention, the vascular activity in it will be increased, and its function will be intensified. An assertion boldly made to a hypnotized person may influence belief in opposition to former experience, and if it be towards an ideational centre, some particular notion may so monopolize the consciousness that discrimination and judgment may become almost as completely in abeyance as in ordinary dreaming.

## OUR BOOK SHELF.

*Physiography: Elementary Stage.* By J. Spencer, B.Sc., F.C.S. (London: Percival and Co., 1891.)

As an introductory science, physiography is one requiring very careful treatment. Its range is undoubtedly wide, but it is correspondingly shallow, and should rather lead up to scientific thought than aim at giving an incoherent collection of facts. In the book before us, the author, who is head master of one of our most successful technical colleges, begins well by recommending that teachers should endeavour to make the subject a practical one, by the performance of experiments, excursions into the neighbouring country, and the collection of specimens of rocks, minerals, and fossils. The experimental shape which the book has consequently taken is one of its most noticeable features; but it certainly falls short of the expectations raised. The chemical and physical parts appear to be excellent, but there is little to assist either teacher or student in gleaning information from the inspection of natural phenomena. A peat bog, for instance, is a fruitful subject for study under proper guidance; but this is not afforded by the scanty remarks on p. 89. In dealing with a wide subject, brevity is essential, but this does not necessitate the omission of the fundamental points, and looseness of expression. The book, however, shows many signs of a want of care in this respect. In the note on Foucault's pendulum (p. 210), for example, the whole point of the explanation is lost by the absence of a reference to the permanence of the plane of swing. On p. 113, it is stated that "submarine volcanoes produce new land, the erupted matter being piled up sufficiently high to form islands"; the omission of the qualifying word "sometimes" might obviously lead to a misconception. Test questions, original and selected, are given at the end of each chapter.

The book is well illustrated, and, with careful revision, should make a useful addition to existing text-books.

*Mayhew's Illustrated Horse Doctor.* Revised and Improved by James Irvine Lupton, F.R.C.V.S. (London: Griffith, Farran, and Co.)

THE continued existence of domestic medicine, whether the subjects of its application be human beings or domesticated animals, cannot well be doubted. We may, however, be permitted to doubt whether true economy lies in this direction. Nevertheless, as residents in the colonies, and even in many rural districts of our own country, are often far removed from the qualified veterinarian, and considerable time must necessarily elapse before his services when sought can be forthcoming, it is obviously advisable that whatever measures are taken by the stock-owner to ameliorate the sufferings of the animal during this interval of time should be rational, and follow lines similar to those which the professional man would adopt. Wrong methods of procedure would serve only to handicap and hamper his efforts. The book before us can be recommended to guide the horse-owner in such emergencies; though we note with pleasure that the reviser, on p. 553, points out that "the reader will always best consult his interest and pocket by at once consulting a qualified veterinarian." Agreeing with this proposition, we cannot but consider superfluous the introduction of minute directions for the performance of such delicate and difficult operations as the extirpation of the eye-ball, the division of the plantar nerves (neurotomy) in some forms of foot-lameness, and section of contracted tendons (tenotomy). We can scarcely conceive an owner, however intelligent and courageous he may be, proceeding to cast, chloroform, and perform any of the above-mentioned operations.

Horse-owners will do well to note the stress which is laid upon the construction, ventilation, and drainage of

stables, and the varied information given on the prevention of disease. The reviser has scant sympathy with the use of the actual cautery; but here he is on debatable ground, and, notwithstanding his strictures, we fancy veterinarians will not lightly lay aside an agent which, rightly or wrongly, most of them believe to be potent for good.

The illustrations form the least satisfactory portion of the work. Many of them are grotesque and ludicrous to the last degree, and ought to have been eliminated from the present revised edition. Some, such as those indicative of the symptoms of colic, are good, and well convey their intended meaning.

W. F. G.

*Handleiding tot de Kennis der Flora van Nederlandsch Indië.* Door Dr. J. G. Boerlage. Tweede Deel, "Dicotyledones Gamopetalæ." Eerste Stuk, "Inferræ—Heteromera"; Caprifoliaceæ—Styracaceæ." (Leyden: E. J. Brill, 1891.)

PREVIOUS parts of this work have been noticed in these columns. It is more than thirty years since the last part of Miquel's "Flora Indiæ Batavæ" appeared, a work written chiefly in Latin; but the present publication cannot be regarded as replacing it, or as being a successor to it. So far as we have tested this "Manual," it is a Dutch translation of the descriptions of the natural orders and genera in Bentham and Hooker's "Genera Plantarum," followed by a list of the species inhabiting the Dutch Indies. Locally it may be serviceable; but what is wanted by botanists generally is a new descriptive elaboration of the species of the region in question.

W. B. H.

*By Sea-shore, Wood, and Moorland: Peeps at Nature.* By Edward Step. (London: S. W. Partridge and Co., 1891.)

THE author of this book, under his pseudonym "James Weston," published in 1886 "Stories and Pictures of Birds, Beasts, and Fishes"; and, two years later, a companion volume, "Stories and Pictures of Animal Life." Both of these volumes, which were very popular, are now out of print. In the present work they have been amalgamated, and the author has added to them some brief "nature-papers" which he has contributed to various periodicals. The book is intended chiefly for young people, and it is so pleasantly written that children who have a chance of reading it can hardly fail to find it attractive. They will obtain from it much interesting information about all sorts of animals, and it will help them to realize that even the most familiar objects, when properly observed, may be worthy of close study. The book is very carefully illustrated.

#### LETTERS TO THE EDITOR.

[The Editor does not hold himself responsible for opinions expressed by his correspondents. Neither can he undertake to return, or to correspond with the writers of, rejected manuscripts intended for this or any other part of NATURE. No notice is taken of anonymous communications.]

#### Note on the Chromosphere Spectrum.

WITH the new spectroscopie of the Halsted Observatory, which has a 5-inch Rowland grating of 20,000 lines to the inch, I have repeatedly observed of late that the bright chromosphere line, Angström 6676·9 (No. 2 in my catalogue of chromosphere lines), is not coincident with the corresponding dark line of the solar spectrum, but is *less refrangible* by about one-third of a unit of Rowland's scale. This chromosphere line, therefore, can no longer be ascribed to iron, but must be due to some other substance as yet undetermined.

I think there can be no doubt as to the non-coincidence. The interval between the bright and dark lines varies to some extent with circumstances, being usually less in the chromo-

sphere spectrum on the sun's eastern limb than on the western, and it is often affected by motions in the line of sight; but nine times out of ten the want of coincidence is perfectly obvious.

I may add that I have also obtained a considerable number of photographs of the ultra-violet spectrum of the chromosphere with the new instrument, and get complete confirmation of almost all Mr. Hale's results. I find not only the constant reversal of the H and K lines, but I have obtained, so far, five of the ultra-violet series of hydrogen lines; the first of them being the well-known "companion" of H (first visually observed by myself in 1880), and the other four in their regular succession above it.

The only point in which my plates fail to confirm Mr. Hale's is that I have not yet succeeded in catching the duplicity of the hydrogen  $\alpha$  (3889). Several of his plates show at this point two lines near together; none of mine do so, and I conclude that the companion line makes its appearance only rarely. I first observed this line visually in 1883 (*American Journal of Science*, November 1883), and it has since been often seen here by my assistant, Mr. Reed, as well as by myself.

Of course the opinion is no longer tenable that H and K can be due to hydrogen, since the measures clearly show that the companion to H belongs to the hydrogen series. But I am still sceptical whether they are due to calcium, at least in its terrestrial condition.

C. A. YOUNG.

Princeton, N. J., U. S., October 20.

#### Formation of a Temporary Cyst in the Fresh-water Annelid *Zoelasma*.

AS I am not aware that the formation of a temporary chitinous cyst has been described in any Oligochaetous Annelid, the following observations may be of some little interest. A few days ago Mr. Latter, science master at the Charterhouse, kindly forwarded to me three tubes containing a quantity of *Zoelasma quaternarium*. They were so abundant that every drop of water contained several specimens; in the water I found also a still larger number of spherical bodies, which proved to be cysts, each completely filled by a single worm coiled once upon itself. The cysts were perfectly colourless and transparent, and very thin-walled; one cyst was found empty, and had been ruptured by the worm in escaping from it. Twenty-six years ago Maggi (*Mem. Soc. Ital. Sci. Nat.*, 1865) described and figured some bodies, oval in form, which he believed to be the cocoons of *Zoelasma*; embryos were found in these cocoons in different stages of development. Prof. Vejdovsky (*Entwickelungsgesch. Unterr.*, Heft 1, Prag, 1888) suggested the possibility that these bodies were really cysts; my own examination of what are, I think, undoubtedly cysts in *Zoelasma* leads me to agree with Vejdovsky's suggested interpretation of Maggi's figures. If the structures which I describe here are really cocoons, their form differs from that of the cocoons of all other Oligochaeta, in being spherical and without a narrow process at either pole; moreover, it is—on the hypothesis that they are cocoons—a remarkable coincidence that they should all contain completely adult worms; finally, and this is of course conclusive, the intestinal tract of the worms contained vegetable detritus. The cysts, as I believe them to be, are of about the size of a *Volvox globator*. In this encysted condition the worms might perhaps be easily transported from place to place; I have found that they survived the evaporation of the surrounding water upon a glass slide for a considerable period; the worms were in continual movement within their cysts, so that it was quite easy to be sure that they were alive. Now this very species has a wide distribution, which may perhaps be partially accounted for by this habit of encystment; with regard to other fresh-water Annelids which have a wide range, such as *Tubifex*, it is possible that birds may inadvertently transport the cocoons from country to country. It is not known yet whether *Zoelasma* forms a cocoon, though it is probable, as the worm develops a clitellum. But sexual maturity appears to be a comparatively rare occurrence in *Zoelasma*; very few observers appear to have seen the sexually mature worms. If this is so, the encystment of the worm may take the place of one of the secondary uses of the cocoon—namely, to aid in the diffusion of the species.

FRANK E. BEDDARD.

#### Polytechnics and Recreation.

IN Mr. Oliver Dawson's article on Polytechnics in your issue of the 8th inst. (vol. xlv., p. 547) he says: "although

those institutes which make much of athleticism and such matters attract the largest proportion of students, the attendance *pro rata* in the class-rooms would not favourably compare with an institute carrying out a purely educational programme." A Polytechnic is mentioned in which, though only seven students entered the class, "scores of young men could be found in the billiard-room and gymnasium"; and the opinion is expressed that even the excellent work of the Regent Street Polytechnic "would be still better if it could be relieved of the recreative element."

May I say a word for recreation, as the representative of a College which will eventually form part of the South London Polytechnic, and which has not been "started by a teacher," but has grown up out of a purely recreative institution, for the Victoria Hall (the parent of the Morley Memorial College) is nothing more, unless we use the word in a very narrow sense.

It is a commonplace truth that the aim of education should be to develop the whole man, not to make mere intellectual experts any more than mere manual experts. Surely recreation has not only a legitimate but a very important place in this, especially where sedentary workers are concerned. Those whose tastes are naturally studious may with comparative safety be left to take care of themselves. In these days, instruction of some sort may be had by most of those who set their minds on it, and if they miss much which books or the living teacher would have enabled them to gain, at least their energy is not likely to be turned into hurtful channels. Those who desire recreation can also get it, and with little exertion; but of what kind? If the gymnasium spoken of above had not been open, what would its scores of frequenters have been doing? Some, no doubt, might have been in class, improving their minds more than they are likely to do in a gymnasium; but others, whose youthful spirits need an outlet, would not have been much attracted by study not associated with recreation. The music-hall, or some of the many forms of betting now prevalent, would have been more likely to entice them. In the confined life of our towns it is no small good to provide athletic sports (apart from temptation to drink) as a safety-valve for boyish spirits, even if the good stops short there. But it need not stop short. Of course, there is danger lest the recreative side of an institute or Polytechnic should swamp the educational, unless care is taken to prevent it. A very simple rule, however, is sufficient for this. Our members are not allowed to use the gymnasium or recreation rooms unless they are *bona fide* students of at least one class. It is not sufficient that they should take a ticket for a class. The registers are occasionally looked over, and if frequent absence from class is combined with frequent attendance in the gymnasium or recreation rooms, a warning, suspension, or even expulsion, is the consequence. We have found that only in an insignificant number of cases is it necessary to proceed to the last resort. Our students as a rule receive an excellent character for steady work from such of our teachers as are in a position to compare them with other students. "I am tired of teaching lads who are trying not to learn," said one who held an important position in a large educational establishment; "your fellows mean business; it's a pleasure to teach them." And the testimony of others is to the same effect.

If the moving spirits of a Polytechnic love work themselves, and if they are careful to enlist the sympathy of students, so as to lead them by example rather than drive them by rigid rule, then there is little danger of the institution degenerating into a mere place of amusement.

EMMA CONS.  
Samuel Morley Memorial College, Waterloo Road, S.E.,  
October 16.

"W = Mg."

I SHOULD like to take exception to Prof. Greenhill's statement in your issue of September 24 (vol. xiv, p. 493) that "when goods are sold in commerce by weight, they are weighed in scales, and the weight is the same wherever the weighing is carried out, whether at the equator, or the poles, or in the Moon, Sun, or Jupiter." In this country it is the commonest thing in the world to see goods sold in commerce weighed in a spring-balance, which is also the universal kitchen weighing apparatus, and I respectfully submit that the weight indicated would not be quite the same in the Moon, Sun, or Jupiter.

The appeal to the scales seems to me to be an attempt to throw dust in our eyes, as what Prof. Greenhill really means is that two equal weights are equal (not each the same) wherever

the weighing is carried on—a balance telling us nothing about the weight, or pull downwards, of either one.

I was fortunate in getting some of my first notions of dynamical measurements from Thomson and Tait, and hence the appearance of the "blooming  $g$ " did not seem unnatural, for after I had learned how to measure a force properly in dynamical units, I was told that a pound's weight =  $g$  poundals, or a gram's weight =  $g$  dynes, which suffices for reduction to non-absolute units. This, in my opinion, is virtually the same as Prof. Slate's suggestion. I never could see why  $g$  should appear in dynamical formulas: measure in absolute units, and at the end reduce to pounds' weight from poundals as above. Of course this involves knowing what an absolute dynamical unit is, and it strikes me that a few more "horizontal" experiments with spring-balances, graduated in poundals or dynes, and a little less thinking about arm balances, would go far to clear up difficulties in the minds of students.

ARTHUR G. WEBSTER.

Clark University, Worcester, Mass., October 14.

[It will be interesting to see if Mr. Webster can devise a horizontal spring dynamometer which will record within 10 per cent. of the true value; also to know what corrections he would apply for the inertia, temperature, and fatigue of the spring, and how he would occasionally test the indications. These difficulties have to be met in Diagrams given by Steam-Engine Indicators. How does the Inspector of Weights and Measures test Spring-Balances in America?—A. G. G.]

Alum Solution.

PERHAPS the following evidence of the *practical* superiority of potash alum solution to distilled water in adiabaticity, when the electric arc is the radiant and the "radiometer" a Crookes, may be of interest. The same glass-celled cell was used throughout, and the difference of voltage between the carbons ("Apostle") was kept sensibly constant (40 volts) through the experiments. Between each observation on the liquids the radiation from the arc was observed unimpeded, save by the glass of the radiometer, as recorded below. The time was given by a metronome (previously examined for constancy) beating half-seconds. No lens was used.

	No. of revolutions of radiometer arms.	Time in half-seconds.
1. Unimpeded radiation ...	25	160
2. Through empty cell ...	25	254
3. Unimpeded radiation ...	25	152
4. Cell + water ...	25	820
5. Unimpeded radiation ...	25	164
6. Cell + water (second experiment) ...	25	832
7. Unimpeded radiation ...	25	160
8. Cell + alum solution ...	25	43,200
	(time of two revolutions actually taken.)	
9. Unimpeded radiation ...	25	160

The current throughout was 6.4 amperes, thickness of each glass plate 1.5 mm., thickness of solution 50 mm., distance of radiometer from arc 1 metre.  
T. C. PORTER.  
Eton College, October 29.

The Salt Lake of Aalia Paakai.

I HAVE recently made an analysis of the water of the salt lake of Aalia Paakai, near Honolulu, and have thought that the results might be of interest to the readers of NATURE. The lake occupies the crater of an immense tuff cone, whose ejecta cover several square miles, and are especially remarkable for containing numerous aggregations of crystalline grains of pure olivine. The lake is just at mean sea-level, and is scarcely a mile distant from the ocean, but there is evidently no free communication with the waters of the sea.

During the dry months crusts of salt are deposited, sometimes six inches or more in thickness, on the bottom of the lake, and the salt has at times been taken out for use. In the rainy season the salt is wholly redissolved. The crust of salt is at the present

time from one to three inches thick, and the water is, of course, a saturated brine. It is interesting to note, however, that it does not correspond in composition with the water from the ocean. Like the Dead Sea, the lake contains an excessive quantity of calcium salt.

The interior of the crater basin is crusted in many places with deposits of carbonate of calcium, proving that it was at one time occupied by a highly calcareous water, probably of high temperature. I have given in connection with the results of my analysis, which extends only to the constituents present in large amount, an analysis of concentrated sea-water from the salt works of Kakaako, and an average of a number of analyses that have been made of the waters of the Dead Sea. These latter sometimes contain a larger proportion of solids than the average figure, but in no analysis that I have seen has the quantity been as large as that found in the water of Aalia Paakai.

Constituents.	Water of the Salt Lake.	Water of the Dead Sea.	Concentrated sea-water.
	Grains per gallon.	Grains per gallon.	Grains per gallon.
Chloride of sodium ...	6989	5137	13239
Chloride of calcium ...	7742	2077	Absent
Chloride of magnesium	7790	8235	3779
Bromide of magnesium	99	208	57
Sulphate of magnesium	Absent	Absent	2478
Sulphate of calcium ...	34	58	22
Chloride of potassium	156	736	534
Total solids... ..	22,810	16,451	20,109
Weight of one wine gallon (approximate)	73,044	68,900	72,180

Honolulu, October 16.

A. B. LYONS.

#### *Meretrix*, Lamarck, 1799, versus *Cytherea*, Lamarck, 1806.

IN the notice of Mr. Newton's "List of Mollusca," in NATURE of October 29 (vol. xlv. p. 610), I read as follows:—"Many old favourites have been thus relegated to obscurity, whilst fresh names, dug up from some forgotten corner, have, by the law of priority, taken their places." Thus, *Meretrix*, Lamarck, 1799, takes the place of his better-known *Cytherea* of 1806, the latter having been applied by Fabricius, in 1805, to a dipterous insect."

The Dipterous *Cytherea obscura*, Fab. 1805, was described nine years later than *Mutio obscurus*, Latreille (1796), which is the same species. Meigen, in his principal work (1820), acknowledged the priority, and the insect has been called *Mutio* ever since. As the typical species is the same for both genera, there is no chance whatever for *Cytherea* to be resuscitated, and it may well remain as the name of the Mollusk. I most heartily agree with the opinion of the reviewer, that "it would be an immense gain if every name proposed to be altered had to pass through a regularly-constituted committee of investigation before it was accepted and allowed to pass current." In such a committee, besides priority, two other paramount scientific interests should be consulted, and they are—*continuity* and *authority*.

Heidelberg, November 1.

C. K. OSTEN SACKEN.

#### A Plague of Frogs.

I HAVE just read with great interest the letter in NATURE of the 5th inst. (p. 8), signed R. Haig Thomas, *à propos* of frogs entering his cellar.

During the past seven years I have resided in three separate lodgings (no two being within half a mile of the other), each having a small garden at the back surrounded by a solid wall. The lowest of these was about 5 feet, and in two cases the walls were quite bare. In the third case there were creepers on both sides. But in all three cases has *one* frog suddenly made its appearance, and always during very wet weather. To account for their entrance has completely puzzled me.

B. A. MUIRHEAD.

Pall Mall Club, Waterloo Place, November 8.

NO. 1150, VOL. 45]

#### Red Light after Sunset.

THERE was at Lyons, N.Y., last evening, a magnificent display of red light similar to the sunset glows which attracted so much attention a few years ago. The entire western sky was of a deep lurid red, resembling a conflagration, for three-quarters of an hour or more after sunset.

M. A. VEEDER.

Lyons, N.Y., October 30.

#### Topical Selection and Mimicry.

WILL you permit me to make a few remarks on Dr. A. R. Wallace's review of my book ("On the Modification of Organisms" which appeared in your journal on April 9 last (vol. xlii. p. 529)? I cannot disguise from myself the fact that in attempting any reply I labour under great disadvantages: first, in having to combat the statements of such a high authority as Dr. Wallace; and secondly, in writing as I am from the Antipodes, my reply cannot reach your readers for at least three months after the publication of the review in question. Nevertheless there are two statements made by him which demand some notice from me.

The first is that I have misrepresented Darwin's views on the question of natural selection. My reply to this is distinct and emphatic. The references to Darwin in my book are absolutely correct; there is no misrepresentation; there is no misquotation. In every reference to Darwin's views I gave the page and the edition from which the quotation was taken. In writing my book I was perfectly aware how important it was to start with a clear understanding of what Darwin meant by the term natural selection, and I was at the utmost pains to quote his exact words in every reference I made to him. It is not my fault if Darwin did not give a clear or consistent definition of natural selection, or that he confounded cause with effect, as when at one time he defined natural selection as "the struggle for existence," and at another time as "the survival of the fittest." I can therefore with the utmost confidence refer your readers to the book itself in confirmation of what I here state.

Dr. Wallace has also been good enough to give, as a sample of my "teaching," a part of a sentence of mine on the subject of mimicry. He says your readers "may estimate the value of Mr. Syme's teaching by his explanation of mimicry, which is, that natural selection has nothing to do with it, but that insects choose environments to match their own colours. He tells us that these extraordinary resemblances only occur among insects that are sluggish, and that 'to account for the likeness to special objects, animate or inanimate, we have only to assume that these defenceless creatures have intelligence enough to perceive that their safety lies in escaping observation.'"

Now I did not state that these extraordinary resemblances occurred only among insects; what I said was that they occurred "chiefly" among insects. I am aware that, judging from Dr. Wallace's standpoint, I may have disposed of the subject of mimicry in a somewhat off-hand way, and for the simple reason that I regarded mimicry as a subordinate branch of the more important subject of protective coloration, which I had treated at some length; and in adopting this course I was taking as my guide Dr. Wallace himself, who has elsewhere stated that "the resemblance of one animal to another is of exactly the same essential nature as the resemblance to a leaf, or to bark, or to desert sand, and answers exactly the same purpose" ("Natural Selection," p. 124, 2nd edition). So far, then, I may presume that I am in good company. To understand what I said about mimicry, therefore, it is necessary to know my views on protective coloration. Protective coloration I regarded as, in certain cases, the result of heat and light acting on the pigment cells, and, in other cases, the result of what, for want of a better name, I may call topical selection—that is, the selection by the animal of its environment. Obviously, this environment would be a cover or background which would enable the animal to escape observation, as by that means many animals, especially such as are not possessed of great speed or great powers of flight, might elude their enemies, or, if Carnivora, might steal upon their prey unawares. No doubt there is something captivating in the idea of a universal cause to which every change in the organic world may be referred; but it is surely contrary to the rules of right reasoning to invoke the aid of a greater force than is necessary to account for a given result. This is what the Darwinist does, however, in order to explain the phenomena of protective coloration and mimicry. It is well known, however, and it has been pointed out by Dr. Wallace himself, that certain



varieties of protectively coloured insects are frequently confined to very limited areas. Some will only be found on a certain species of tree or plant; others only on rocks or a stone wall of some particular colour; others, again, only on small patches of soil or gravel; while a short distance from these there may be other objects differently marked, which may be frequented by insects altogether different in colour, although belonging to the same or to an allied species. Are we to suppose that every tree, plant, rock, every stone wall, and every distinctive patch of soil or gravel, has been the scene of natural selection? There is no other conclusion open to the Darwinist. But when it is considered that natural selection may take hundreds of thousands or even millions of years, to effect a given result, the strain upon our forbearance must be great when we are asked to believe that this process is the only one we have to reckon with. If the phenomena can be accounted for by a shorter or simpler process, why should the longer and more complex one be insisted on? Is it not more reasonable to suppose that animals have sufficient intelligence to fly to, and remain in, the place where experience has shown they are least exposed to observation? Can anyone doubt that animals possess such knowledge? How otherwise are we to explain the action of the butterfly, for instance, in darting at once when disturbed to some object which resembles itself, and then lying perfectly still, when one might in vain attempt to find it, although within a few inches of it?

This view also receives corroboration from the fact that many unprotected animals render themselves inconspicuous by covering themselves with materials which resemble their environment. Thus certain Lepidopterous larvæ form cases for themselves out of the fragments of the substance on which they feed, the cases of the larvæ of the Psychidæ, for instance, being made of leaves or of brown grass stems; those of the Essex emerald moth of fragments of leaves spun together with silk; certain species of sea-urchins and many Mollusca cover themselves with grains of sand, shell, and bits of stone, while, according to Poulton, certain species of crabs fasten species of seaweed to their bodies for the same purpose.

Topical selection will also explain the protective coloration of certain vertebrates, as rabbits, hares, and deer. Thus Mr. H. A. Brydon, who has an extensive acquaintance with the habits of deer in South Africa, writes ("Kloof and Karoo," p. 298) as follows:—

"In some localities where the 'zuur veld' clothes the upper parts of the mountains, and the 'rooi' grass the lower portions, the vaal and the rooi rhebok may be found on the same mountain-side, but each adhering to its own peculiar pasturage. When the hunters come upon the ground to shoot, the rooi rhebok immediately fly from their lower slopes to the higher ground of their grey brethren, and the two species are seen galloping in close company over the mountain heights. If the hunter rests quietly after his shot and looks about him, he will presently see the two kinds of antelope, as soon as they think they may safely do so, separating, the rooi rhebok quitting the 'vaal' pastures, and betaking themselves again to their own feeding-grounds. To this habit they invariably adhere, and will not delay their departure an instant longer than their safety admits of. If the vaal rhebok in turn are driven out of their own ground, they pursue exactly the same tactics, and will on no account remain for long in their red brethren's territory."

The occurrence of so many trimorphic and polymorphic varieties of the same species have always been a puzzle to Darwinists, as the numerous varieties which the Darwinian theory postulates would all be killed off by natural selection, except the "fit"; but according to the theory which I have advanced, most variations would find their appropriate environments and live. If this theory of topical selection be correct, its application to the phenomena of mimicry is obvious. We have only to suppose that one animal may find safety in associating with another animal to which it has some resemblance, without invoking the aid of either mimicry or natural selection.

I shall not attempt to reply to the other remarks of your critic further than this, that no one who contents himself with reading Dr. Wallace's review will be able to form the slightest idea of the views put forth in my book. That it has taken a lifetime, as Dr. Wallace correctly enough says it has, to build up "the vast edifice" of Darwinism is surely no guarantee of the truth of that system, and certainly no reason why it should be above criticism, as my reviewer seems to think it should be.

Melbourne, 1891.

DAVID SYME.

MR. SYME now says: "The references to Darwin in my book are absolutely correct," and—"In every reference to Darwin's views I gave the page and the edition from which the quotation was taken." Assertions, however, are not proofs; but if Mr. Syme will point out where Darwin defines natural selection as "the struggle for existence," and where Darwin "insists that variations are created by natural selection," statements which occur at p. 8 and p. 15 of Mr. Syme's book, I will acknowledge that I have misrepresented him. Otherwise I see nothing that requires modification in my article. But as Mr. Syme claims to have taken "the utmost pains" to quote Darwin's exact words, I will refer to other cases. At p. 12 he says, "The second assumption is that favourably modified individuals should be few in number, 'two or more';" and for this he refers to "Plants and Animals under Domestication," vol. ii. p. 7. The true reference is to vol. i. p. 7, where Darwin says: "Now, if we suppose a species to produce two or more varieties, and these in course of time to produce other varieties, &c." Here we see that Mr. Syme puts "individuals" in the place of "varieties," and thus makes Darwin appear to say the exact reverse of his main contention, which is, that ordinary variability occurring in large numbers of individuals, not single sports, are the effective agents in the modification of species.

Again, at p. 102, Mr. Syme says, when discussing cross-fertilization and variability: "No doubt self-fertilization is a great factor in producing uniformity of colour. That this uniformity is not due to the plants having been 'subjected to somewhat diversified conditions,' as Darwin intimates, is shown by the fact, &c." But Darwin, as every student knows, said exactly the reverse of this—that the somewhat diversified conditions produced *variability*; and Mr. Syme's great efforts to understand him and to quote him correctly again fail of success.

One more example is to be found at p. 110, where he says: "Darwin has distinctly laid down the principle that if it can be proved, by a single instance, that one organism exists for the benefit of another organism, his whole system would fall to the ground." But the statement made by Darwin was, that if any part of the structure of one species could be proved to have been formed for the *exclusive* good of another species it would annihilate his theory ("Origin," 6th edition, p. 162). Mr. Syme omits the essential word "exclusively," and thus appears to have a strong case against the theory.

As an example of general misrepresentation, I will refer to p. 86, where Mr. Syme states that "the Darwinist" "carefully ignores the facts which point in the opposite direction" (of the necessity for insect fertilization of flowers); and on the next page, after referring to cleistogamic and other self-fertilized flowers, he asks: "Why does the Darwinist omit mention of such structures as these?" But he does not refer us to the Darwinists in question who, while discussing insect fertilization, "carefully ignore" self-fertilization; and as his statement will be taken to include all, or at least the majority of Darwinists, it must be held, by those who are acquainted with the facts, to be a very absurd misrepresentation.

Other examples might be given, but these are sufficient to support my statement that Mr. Syme has both misquoted and misrepresented Darwin.

The exposition of his theory of "topical selection" to explain the phenomena of mimicry, as given above, may be left to the judgment of the readers of NATURE.

ALFRED R. WALLACE.

#### PROF. PICTET'S LABORATORY AT BERLIN.

IT has often been remarked that purely scientific research frequently bears fruit of practical value. A fresh illustration of this fact is afforded by the work of Prof. Pictet, the eminent man of science of Geneva, who is turning to practical account the apparatus by which, in 1877, he first reduced hydrogen and oxygen to the liquid state. At Berlin, where he now resides, he has established, on the scale of a small factory, what he terms a "laboratoire à basses températures." The following account of the work carried on and the results obtained is taken from papers read by the Professor before different scientific Societies of Berlin.

The refrigerating machinery, driven by several powerful

steam-engines, is intended to withdraw heat from the objects under observation, and to keep them at any temperature between  $-20^{\circ}$  and  $-200^{\circ}$  C. as long as may be required. Prof. Pictet's experience has led him to the conclusion that among the refrigerating agents known, such as rarefaction of gases, dissolution of salts, evaporation of liquids, the latter is to be preferred. A long course of research has further enabled him to choose the most convenient from amongst the great number of suitable liquids. In order to avoid the great pressure required in handling the highly evaporative substances of lowest boiling-point which serve to produce extreme cold, it is necessary to divide the difference of temperature into several stages. Each stage is fitted with especial apparatus consisting of an air-pump worked by steam, which drains off the vapours of the liquid from the refrigerator, and forces them into a condenser, whence, reduced to the liquid state, they are again offered for evaporation in the refrigerator. Thus the liquid, without any loss beyond leakage, passes through a continuous circuit, and the operations can be carried on for any length of time. The liquid made use of for the first stage is the mixture of sulphurous acid and a small percentage of carbonic acid called "*liquide Pictet*." It is condensed at a pressure of about two atmospheres in a spiral tube merely cooled by running water. Oxide of nitrogen (laughing gas) is the liquid chosen for the second stage. Its vapours are condensed in the same way at a pressure about five or six times as great in a tube maintained at about  $-80^{\circ}$  by the action of the first circuit. As medium for a third stage, in which, however, continuous circulation has not yet been attempted, atmospheric air is employed, which passes into the liquid state at a pressure of no more than about 75 atmospheres, provided the condenser is kept at  $-135^{\circ}$  by the first two circuits. The evaporation of the liquefied air causes the thermometer to fall below  $-200^{\circ}$ .

By this combination quite new conditions for investigating the properties of matter are realized. In various branches of science new and surprising facts have already been brought to light. Many laws and observations will have to be re-examined and altered with regard to changes at an extremely low temperature.

For instance, a remarkable difference was noted in the radiation of heat. Material considered a non-conductor of heat does not appear to affect much the passage of heat into a body cooled down to below  $-100^{\circ}$ . Or, to state the fact according to Prof. Pictet's view: "The slow oscillations of matter, which constitute the lowest degrees of heat, pass more readily through the obstruction of a so-called non-conductor than those corresponding to a higher temperature, just as the less intense undulations of the red light are better able to penetrate clouds of dust or vapour than those of the blue." If the natural rise of temperature in the refrigerator, starting from  $-135^{\circ}$ , is noted in a tracing, and afterwards the same refrigerator carefully packed in a covering of cotton-wool of more than half a yard in thickness, and cooled down afresh, and the rise of temperature again marked, on comparing the tracings hardly any difference will be found in the two curves up to  $-100^{\circ}$ , and only a very slight deviation even up to  $-50^{\circ}$ . On this ground it is clear that the utmost limit of cold that can possibly be attained is not much lower than that reached in the famous experiment of liquefaction of hydrogen. The quantity of warmth which hourly floods a cylinder 1250 mm. high by 210 mm. wide (the size of the refrigerator) at  $-80^{\circ}$ , is no less than 600 calories, and no packing will keep it out. At a lower temperature, the radiation being even greater, the power of the machinery intended to draw off still more heat would have to be enormous. And as  $-273^{\circ}$  is absolute zero, the utmost Prof. Pictet judges to be attainable is about  $-255^{\circ}$ .

As an example of the surprising methods which the

refrigerating machine permits the investigator to employ, it may be mentioned that, in order to measure the elasticity of mercury, Prof. Paaizow had the metal cast into the shape of a tuning-fork, and frozen hard enough for the purpose in view. On this occasion it appeared that quicksilver can be shown in a crystallized state, the crystals being of a beautiful fern-like appearance.

Glycerine was likewise made to crystallize; and cognac, after having been frozen, was found to possess that peculiar mellowness commonly only attained by long keeping.

But the most important application of the refrigerating machinery has been the purification of chloroform, undertaken by Prof. Pictet at the instance of Prof. Liebreich, of the Pharmacological Institute, Berlin. Chloroform has hitherto been considered a most unstable and easily defiled substance. The action of sunlight, the slight impurities retained from the different processes of manufacture, perhaps the mere settling down during protracted storage, have invariably resulted in a more or less marked decomposition. By the simple process of crystallization this unstableness is got rid of, and a practically unchangeable liquid is produced. The crystals begin to form at  $-68^{\circ}$ , first covering the bottom of the vessel, and gradually filling it up to within one-fifth of the whole volume. This residue being drained off, the frozen part is allowed to melt under cover, so as to exclude the atmospheric moisture. Chloroform thus refined has, by way of testing its durability, remained exposed on the roof in a light brown bottle from November till June without the slightest sign of decomposition.

Prof. Pictet has already taken steps to introduce his process into manufacture, and proposes to apply the principle to various other chemical and technical objects. Sulphurous ether, for instance, has by a similar process been produced in a hitherto unknown degree of purity. At the same time, the Professor continues eagerly to pursue the various purely scientific inquiries with which he started.

R. DU BOIS-REYMOND.

#### RESULTS OF EXPERIMENTS AT ROTHAMSTED ON THE QUESTION OF THE FIXATION OF FREE NITROGEN.<sup>1</sup>

FROM the results of the experiments of Boussingault, and also of those made at Rothamsted under conditions of sterilization and inclosure more than thirty years ago, Sir J. B. Lawes and the author had always concluded that at any rate our agricultural plants did not assimilate free nitrogen. They had also abundant evidence that the Papilionaceæ, as well as other plants, derived much nitrogen from the combined nitrogen in the soil and sub-soil. Still, they had long recognized that the source of the whole of the nitrogen of the Papilionaceæ was not explained; that there was, in fact, "*a missing link*"! They were, therefore, prepared to recognize the importance of the results first announced by Prof. Hellriegel in 1886; and they had hoped to commence experiments on the subject in 1887, but they had not been able to do so until 1888. Those first results showed a considerable formation of nodules on the roots, and coincidentally great gain of nitrogen, in plants grown in sand (with the plant-ash) when it was microbe-seeded by a turbid watery extract of a rich soil.

In 1889 and since, they had made a more extended series. The plants were grown in pots in a glass-house. There were four pots of each description of plant, one with sterilized sand and the plant-ash, two with the same sand and ash, but microbe-seeded with watery extract, for some plants from a rich garden soil, for lupins from a sandy soil in which lupins were growing luxuriantly, and

<sup>1</sup> Abstract of a paper read before the Agricultural Chemistry Section of the Naturforschers Versammlung at Halle a.S., by Dr. J. H. Gilbert, F.R.S., September 24, 1891.

for some other plants from soil where the particular plant was growing. In all, in 1889 and subsequently, they had grown in this way four descriptions of annual plants—namely, peas, beans, vetches, and yellow lupins; and four descriptions of longer life—namely, white clover, red clover, sainfoin, and lucerne. Enlarged photographs of the above ground-growth, and of the roots, of the peas, the vetches, and the lupins, so grown, were exhibited. Without microbe-seeding there was neither nodule-formation nor any gain of nitrogen; but with microbe-seeding there was nodule-formation, and, coincidentally, considerable gain of nitrogen.

As, however, in this exact quantitative series, the plants were not taken up until they were nearly ripe, it was obvious that the roots and their nodules could not be examined during growth, but only at the conclusion, when it was to be supposed that the contents of the nodules would be to a great extent exhausted. Another series was, therefore, undertaken, in which the same four annuals, and the same four plants of longer life, were grown in specially made pits, so arranged that some of the plants of each description could be taken up, and their roots and nodules studied, at successive periods of growth: the annuals at three periods—namely, first when active vegetation was well established, secondly when it was supposed that the point of maximum accumulation had been approximately reached, and thirdly when nearly ripe; and the plants of longer life at four periods—namely, at the end of the first year, and in the second year when active vegetation was re-established, when the point of maximum accumulation had been reached, and lastly when the seed was nearly ripe. Each of the eight descriptions of plant was grown in sand (with the plant-ash), watered with the extract from a rich soil; also in a mixture of two parts rich garden soil and one part of sand. In the sand the infection was comparatively local and limited, but some of the nodules developed to a great size on the roots of the weak plants so grown. In the rich soil the infection was much more general over the whole area of the roots, the nodules were much more numerous, but generally very much smaller. Eventually the nodules were picked off the roots, counted, weighed, and the dry substance and the nitrogen in them determined.

Taking the peas as typical of the annuals, and the sainfoin of the plants of longer life, the general result was, that at the third period of growth of the peas in sand the amount of dry matter of the nodules was very much diminished, the percentage of nitrogen in the dry matter was very much reduced, and the actual quantity of nitrogen remaining in the total nodules was also very much reduced. In fact the nitrogen of the nodules was almost exhausted. The peas grown in rich soil, however, maintained much more vegetative activity at the conclusion, and showed a very great increase in the number of nodules from the first to the third period; and with this there was also much more dry substance, and even a greater actual quantity of nitrogen, in the total nodules at the conclusion. Still, as in the peas grown in sand, the percentage of nitrogen in the dry substance of the nodules was very much reduced at the conclusion. In the case of the plant of longer life, the sainfoin, there was, both in sand and in soil, very great increase in the number of nodules, and in the actual amount of dry substance and of nitrogen in them, as the growth progressed. The percentage of nitrogen in the dry substance of the nodules also showed, even in the sand, comparatively little reduction, and in soil even an increase. In fact, separate analyses of nodules of different character, or in different conditions, showed that whilst some were more or less exhausted and contained a less percentage of nitrogen, others contained a high percentage, and were doubtless new and active. Thus, the results pointed to the interesting conclusion, that, in the case of the annual, when

the seed is formed, and the plant more or less exhausted, both the actual amount of nitrogen in the nodules, and its percentage in the dry substance, are greatly reduced, but that, with the plant of longer life, although the earlier formed nodules become exhausted, others are constantly produced, thus providing for future growth.

As to the explanation of the fixation of free nitrogen, the facts at command did not favour the conclusion that under the influence of the symbiosis the higher plant itself was enabled to fix the free nitrogen of the air by its leaves. Nor did the evidence point to the conclusion that the nodule-bacteria became distributed through the soil and there fixed free nitrogen, the compounds of nitrogen so produced being taken up by the higher plant. It seemed more consistent, both with experimental results and with general ideas, to suppose that the nodule-bacteria fixed free nitrogen within the plant, and that the higher plant absorbed the nitrogenous compounds produced. In other words, there was no evidence that the chlorophyllous plant itself fixed free nitrogen, or that the fixation takes place within the soil, but it was more probable that the lower organisms fix the free nitrogen. If this should eventually be established, we have to recognize a new power of living organisms—that of assimilating an elementary substance. But this would only be an extension of the fact that lower organisms are capable of performing assimilation-work which the higher cannot accomplish; whilst it would be a further instance of lower organisms serving the higher. Finally, it may here be observed that Loew has suggested that the vegetable cell, with its active protoplasm, if in an alkaline condition, might fix free nitrogen, with the formation of ammonium nitrite. Without passing any judgment on this point, it may be stated that it has frequently been found at Rothamsted that the contents of the nodules have a weak alkaline reaction when in apparently an active condition—that is, whilst still flesh-red and glistening.

As to the importance of the fixation for agriculture, and for vegetation generally, there is also much yet to learn. It is obvious that different Papilionaceæ growing under the same external conditions manifest very different susceptibility to, or power to take advantage of, the symbiosis. The fact, as shown by Prof. Nobbe, that Papilionaceous shrubs and trees, as well as herbaceous plants, are susceptible to the symbiosis, and under its influence may gain much nitrogen, is of interest from a scientific point of view as serving to explain the source of some of the combined nitrogen accumulated through ages on the surface of the globe; and also from a practical point of view, since, especially in tropical countries, such plants yield many important food materials, as well as other industrial products.

In conclusion, it will be seen that the experimental results which have been brought forward constitute only a small proportion of those already obtained or yet to be obtained at Rothamsted, but they have been selected as being to a great extent typical, and illustrative of the lines of investigation which are being carried out.

#### FOSSIL BIRDS IN THE BRITISH MUSEUM.

IT is always a matter of extreme interest to trace back any group of beings to their first recorded appearance in geological history, and the task becomes the more attractive in proportion to the rarity of the organism sought for.

The fossil remains of birds, which form the subject of Mr. Lydekker's Catalogue, constitute nearly the smallest

<sup>1</sup> "Catalogue of the Fossil Birds in the British Museum (Natural History), Cromwell Road, S.W." By Richard Lydekker, B.A., F.G.S., F.Z.S. Pp. xviii. and 368. (London: Printed by Order of the Trustees, Longmans and Co.; B. Quaritch; Asher and Co.; Kegan Paul and Co., 1891.)

group of vertebrate fossils known; indeed, it is only within the last thirty-five years that any considerable number of species had been recorded.

That the existence of birds at the period of the Secondary rocks should have been first intimated by their foot-prints may seem strange; but as far back as 1835 a notice appeared in *Silliman's American Journal of Science* stating that Dr. Deane had discovered impressions resembling the feet of birds upon some slabs of Triassic sandstone from Connecticut. Dr. Hitchcock, who was the first to submit these tracks to careful scientific examination, concluded that they had been produced by the feet of birds which must have been at least four times larger than an ostrich. The great size of some of these foot-prints, however, presented at the time an obstacle to their acceptance, notwithstanding the fact of their exhibiting the same characteristic number of toe-joints as exist in the feet of living tridactylous birds—namely, three phalangeal bones for the inner toe, four for the middle, and five for the outer one.

The subsequent discovery of the entire skeletons of great wingless birds in New Zealand has, to some extent, destroyed the force of this objection as to their size; nevertheless, it seems more probable that these impressions were made by some of those gigantic Dinosaurs whose remains have been in later years met with in such abundance in the Secondary rocks of the American continent, many of which were bipedal in their method of progression, their fore-limbs being exceedingly short, and but ill adapted for use in walking. The hind-foot in *Iguanodon* and in some others was tridactylous, and agreed in the number of toe-bones with the foot of the *Dinornis* and other flightless birds. But between the discovery of the reputed foot-prints of birds in the Connecticut Valley sandstones, and the finding of true bird-remains in Secondary rocks, a long interval of time has elapsed. Some supposed bird-bones from the Chalk of Burham, near Maidstone, were figured and described as long ago as 1845 by Dr. Bowerbank, under the name of *Cimolornis*, but these proved to belong to a gigantic Pterodactyle, and not to an albatross. The same fate befell Dr. Mantell's Wealden bird (*Palaornis cliffii*, 1844), now also transferred to the Ornithosauria by Mr. Lydekker.

Passing over some fragmentary remains, discovered in 1858 by Mr. Lucas Barrett in the Greensand of Cambridge, referred to birds, we come in 1861 to the discovery, announced by Dr. H. von Meyer, of the impression of a single feather upon a slab of lithographic stone from Solenhofen, Bavaria, followed in 1862 by the description by Prof. Owen of the skeleton of a remarkable long-tailed bird from the same formation and locality, the *Archæopteryx macrura*. This, which is still the earliest-known avian fossil, is also the most generalized bird known; and the discovery, twenty years later, of a second example only serves to confirm the correctness of the conclusions which had been arrived at from a study of the first-found example.

That it was clothed in feathers serves to prove the true avian character of the fossil, no reptile having been met with possessed of such epidermal structures. The remarkable features are that the jaws were armed with conical enamelled teeth implanted in distinct alveoli (see Fig. 1); the three metacarpals in the manus are separate and the phalanges are free (not ankylosed, as in modern birds), and each of the three digits was armed with a terminal claw; the centre of the vertebræ are amphicæalous; there are twenty free vertebræ in the tail, which is longer than the body, each vertebra bearing a pair of feathers, and the tail does not terminate in a pygostyle, like most modern birds.

From these, and other anatomical characters, *Archæopteryx* has been placed in a distinct order, the SAURURÆ, or lizard-tailed birds.

The next important bird discoveries from the Secondary rocks were those made in North America by Prof. O. C. Marsh, in 1870, from the Upper Cretaceous strata of Kansas, U.S., by which we became acquainted with two most distinct and important types, the *Hesperornis* and the *Ichthyornis*. Both of these birds are remarkable as having their jaws armed with teeth. The former (*Hesperornis*) had the teeth implanted in grooves, it had only rudimentary wings, a flat keel-less sternum, and saddle-shaped vertebræ. It was a huge fish-eating diver, nearly 6 feet high, probably resembling in appearance the loons and grebes (see Fig. 2).

The latter (*Ichthyornis*) was a bird of powerful flight, having well-developed wings and a strongly-keeled sternum; its jaws were armed with teeth in distinct sockets, and the vertebræ were biconcave (see Fig. 3).

By far the greater proportion of avian remains known are of Tertiary age; many are referable to existing birds, but a few of them are of almost as great interest to the ornithologist as those already referred to, either as representing, like them, extinct forms, or because they tell of important changes during Tertiary times in the geographical distribution of many genera of birds. The oldest of these remains have been obtained from the London Clay. A single skull of a large ostrich-like bird was obtained from the Lower Eocene of the Isle of Sheppey, and described by Owen in 1869 under the name of *Dasornis londiniensis*. Two limb-bones of a bird as large as an ostrich, but more robust, and with affinities to the Anserine type, as well as to the *Ratitæ*, were obtained about six years ago from the Lower Eocene near Croydon, and described by Mr. Newton under the name of *Gastornis klaasseni*. Two other species of *Gastornis* had previously been described from the Eocene of Meudon and Rheims, in France, so that the *Ratitæ* were doubtless well represented in Western Europe in Tertiary times.

Another remarkable discovery in the London Clay of Sheppey is that of the *Odontopteryx tolapiicus*, a bird with a powerfully serrated bill, well adapted for seizing fish, which probably formed its prey.

The interest attaching to the discovery, fifty years ago, of the bones of extinct ostrich-like birds in New Zealand, remains unabated; their former abundance may be imagined from the fact that there is hardly a museum in the world where remains of the "moa" are not to be found, and they still continue to be sent to Europe for sale. The series of skeletons of *Dinornis* set up in the Vienna Museum is even finer than that in the British Museum. In the latter, six almost complete skeletons may be seen, beside an immense series of detached bones (see Fig. 4). The tallest skeleton is probably 10 feet, and the smallest 4 feet in height. Specimens showing the skin and feathers still attached to the bones are also preserved, evidencing the comparatively modern date at which they were exterminated.

Another island, which possessed a now extinct flightless bird, is Madagascar. Bones and eggs of this great bird, the *Epyornis*, which probably rivalled the *Dinornis* in size, are preserved in the British Museum; but, owing to the lack of exploration in the island, we know as yet of only a few odd bones, where entire skeletons doubtless exist, perhaps as abundantly as in New Zealand. The egg of *Epyornis* is the largest bird's egg known, its liquid contents being rather more than two gallons.

The close affinity existing between birds and reptiles has long ago been an accepted fact in zoology; the finding, therefore, of such primitive birds as *Archæopteryx*, *Hesperornis*, and *Ichthyornis* on the one hand, and of the numerous bird-like Dinosaurs in Europe and America on the other—indeed, the whole tendency of this branch of modern palæontological discovery—has been to strengthen the relationship of the two, and to confirm their association in one primary group of the Vertebrata, the SAUROPSIDA.



FIG. 1.

FIG. 1.—Right lateral aspect of the skull of *Archaeopteryx macrura*, Owen, from the Lithographic stone, Lower Kimmeridgian, Solenhofen, Bavaria (†). (After Dames, "Paläontologische Abhandlungen," vol. ii., 1884.)

FIG. 2.—Restored skeleton of *Hesperornis regalis*, Marsh (1870), from the Cretaceous of Kansas, North America (about  $\frac{1}{2}$  natural size). (Reproduced, by permission, from Prof. O. C. Marsh's "Extinct Toothed Birds of North America" (folio), New Haven, Conn., U.S., 1880.)

FIG. 3.—Restored skeleton of *Ichthyornis victor*, Marsh (1872), from the Cretaceous of Kansas ( $\frac{1}{2}$  natural size). (Reproduced, by permission, from Prof. Marsh's "Extinct Toothed Birds of North America" (folio), New Haven, Conn., U.S., 1880.)

FIG. 4.—Restored skeleton of *Dinornis (Pachyornis) elephantopus*, Owen, from Pleistocene deposits, Oamaru Point, South Island, New Zealand (about  $\frac{1}{15}$  natural size). (Original in British Museum, N.H.)



FIG. 3.



FIG. 2.



FIG. 4.

One very interesting point we may note with regard to the class Aves—namely, that while birds still possessed the teeth which they had inherited from their reptilian ancestors, two very remarkable and distinct types of the class had already made their appearance, and that these two types have persisted on, even to the present day, dividing the class into *Katite* and *Carinate*. The characters of the ancient toothed birds indicate undoubtedly a great antiquity for the class, which was probably evolved from the Reptilia in Triassic times, or even earlier.

Although the majority of entries in Mr. Lydekker's Catalogue relate to the *Carinata*, the *Ratite* are also well represented in the collection, and there is a sufficient number of remarkable extinct forms and figured types to impart to this volume a high scientific interest.

In conclusion, we must express our thanks to Mr. Lydekker for this last contribution to the very useful series of Catalogues which he has prepared for the Trustees of the British Museum, which cannot fail to prove of great service to biological science.

#### IRON CARBONYL FROM WATER GAS.

AT the meeting of the Chemical Society on Thursday last, November 5, a communication was made by Sir Henry Roscoe, M.P., in the joint names of himself and Mr. Scudder, concerning a new and highly interesting mode of formation of iron carbonyl,  $\text{Fe}(\text{CO})_4$ , the volatile compound of iron and carbon monoxide independently obtained a few months ago by M. Berthelot and by Messrs. Mond and Quincke. During the course of experiments upon the application of water-gas, which contains about 40 per cent. of carbon monoxide and an approximately equal quantity of hydrogen, to the purposes of illumination, it was noticed that the magnesia combs placed over the flame of the burning water-gas rapidly became coated with oxide of iron, which materially lessened the illuminating power. Steatite burners were likewise found to become stained with oxide of iron. The deposit, when allowed to accumulate, took a coralloid tuberos form quite different from accumulations of particles mechanically carried in a stream of gas. This led to the supposition that the iron had existed in the water-gas in a volatile form, and was deposited as the result of the decomposition of the volatile compound at the high temperature of the flame. Further experiments were subsequently made with water-gas which had been compressed to eight atmospheres in iron cylinders. After standing for a week in such a cylinder, the gas, which usually burns with a blue non-luminous flame, was found to burn with an intensely yellow flame, and the illuminating power when the magnesia comb was placed over the flame was considerably reduced, owing to the deposition upon the comb of large quantities of oxide of iron. The experiment was repeated before the Fellows of the Society present, and upon depressing the lid of a porcelain crucible upon the flame a black stain was immediately produced, due to the deposition of particles of metallic iron or oxide. Moreover, upon heating the glass tube through which the gas was passing upon its way to the burner, a black mirror of metallic iron was rapidly formed. A thick deposit was also formed upon a plug of cotton-wool inserted in the tube between the heated portion and the burner. A similar tube was exhibited, through which, while heated, one cubic foot of water-gas had been allowed to pass from a cylinder in which it had been stored two weeks; the deposit was strikingly large, both in the portion which had been heated and upon the cotton-wool. After allowing a similar cylinder containing compressed water-gas to stand for five weeks, the flame was found to be smoky, from the large amount of iron liberated during the combu-

tion. The smokiness, and, indeed, the whole luminosity, disappeared upon heating the tube, the gas burning with its ordinary blue flame; a thick mirror was at once deposited, and a large amount of iron retained by the cotton-wool. Thirty litres of gas from this cylinder, burnt during the space of half an hour, gave thirty-two milligrams of metallic iron in the form of a mirror, and forty milligrams were deposited upon the cotton-wool. Upon passing the gas through a U-tube surrounded by ice, a few drops of a turbid liquid were obtained, consisting mainly of iron carbonyl, possessing the properties ascribed to it at the meeting of the British Association at Cardiff by Mr. Mond. The turbidity entirely disappeared upon the addition of hydrochloric acid. From the above experiments it is evident that iron carbonyl is produced in the cold by the action of the carbon monoxide contained in the water-gas upon the iron of the containing cylinder, for the greater the length of time during which it has been stored, the greater is the amount of the compound present. It is interesting to learn that the same deposit of metallic iron or oxide is found upon steatite burners from which ordinary coal-gas is burnt, pointing to the existence of iron carbonyl in our common illuminating gas. This conclusion is strengthened by the fact recorded by Dr. Thorne, that coal-gas which has been compressed in iron cylinders and allowed to stand some time is rendered unfit for use for lantern projection, owing to the deep stain of iron formed upon the lime cylinders. It is also interesting, in view of the fact that iron carbonyl is capable of formation in the cold, to note that the nickel compound,  $\text{Ni}(\text{CO})_4$ , described by Messrs. Mond, Langer, and Quincke last year (*vide NATURE*, vol. xlii. p. 370), is also readily formed in the cold, provided the metallic nickel has been previously heated in a current of hydrogen. A. E. TUTTON.

#### CAPE GUARDAFUI AND THE NEIGHBOURING SEA.<sup>1</sup>

THIS work consists of monthly charts which illustrate the sea surface temperature, the wind, ocean currents, sea disturbance, and weather in the immediate vicinity of Cape Guardafui, extending down the Somali coast so as to include Ras Hafūn, and covering the sea to 53° E. Some years ago the Admiralty issued a "Notice to Mariners," indicating the precautions necessary in rounding Cape Guardafui from the southward, in consequence of the Committee of Lloyd's having drawn attention, through the Board of Trade, to the large number of wrecks which had taken place in the neighbourhood. It was pointed out that the wrecks occurred chiefly during the period of the south-west monsoon, which blows from April to September, when the weather on the African coast is stormy and accompanied by a heavy sea; the currents are strong, and the land is generally obscured by a thick haze. The principal recommendation adopted by the Admiralty was the necessity for every precaution in verifying the vessel's position by soundings; and with this precaution it is asserted that the vessel's safety is assured, as the water rapidly deepens northward of the parallel of the cape. Ignorant of the exact position, many seamen have mistaken the high land at the back of Ras Jard Hafūn, ten miles south of Cape Guardafui, for the latter, which, being lower and lighter in colour, is often invisible at any considerable distance. Believing the cape to be passed, ships have been steered into the comparatively low bay between the two headlands, and have struck on the sandy beach before any warning has

<sup>1</sup> "Meteorological Charts of the Portion of the Indian Ocean adjacent to Cape Guardafui and Ras Hafūn." (London: Published by the authority of the Meteorological Council, 1891.)

been given. An idea was mooted that a change in the sea temperature could be trusted to indicate the position of the ship in latitude, and some experienced captains in the mercantile marine advocated warmly this test, holding that a sea temperature of 80° F. was never found at this season south of Cape Guardafui. The attention of the Meteorological Office was called to these statements, and it was evident that an investigation into the facts would be of great service to the mariner. A preliminary inquiry threw doubt on the view in question, though it was apparent that the temperature was, generally speaking, lower to the south of Cape Guardafui than to the north. The charts now published are the outcome of the inquiry. So far as the practical bearing of the investigation on navigation is concerned, the result, in brief, is that in every month of the year a sea surface temperature above 80° may be found to the southward of Cape Guardafui; and that, although in the months of June, July, and August, when the south-west monsoon is at its height, this occurrence is rarer than at other seasons, the thermometer would prove a very dangerous guide for the purpose suggested.

The primary object of the discussion undertaken by the Meteorological Office was to show the difference of sea surface temperature near Cape Guardafui in comparison with that over the sea to the southward during the south-west monsoon months, from April to September, but more especially in the months of June, July, and August, when the monsoon is most pronounced. In spite of this being the period of the northern summer, the surface water is coldest at this season, and from June to September are the only months during the year that temperatures below 70° are experienced within the area dealt with. It is clear that during the full strength of the south-west monsoon the cold water of the southern hemisphere is driven north of the equator; but on the other hand, although low temperatures are experienced, readings of 80° and above are met with in these months at a considerable distance to the southward of Cape Guardafui; and for a vessel, making a passage from the southward, to reason that she had passed Cape Guardafui because the thermometer indicated a temperature of 80° would be altogether misleading. The temperatures are without doubt more uniformly high in the vicinity of Cape Guardafui than further to the southward during the months of June to September, and this justifies to a very great extent the opinion formed by many leading captains of the merchant service that a safe course might be shaped by the thermometer; but this view is now proved to be erroneous. The sea surface temperature reaches its highest point in the district discussed during the months of March, April, and May, when nearly the whole area is above 80°.

The winds and ocean currents, which are plotted in position on the charts, give features of especial interest. The change of monsoon is well shown, and the effect produced by the adjacent land on the direction of the wind, also the variations in the strength of the monsoon, especially the intensified force of the south-west wind, which reaches its maximum in July, when the winds frequently blow with the force of a whole gale. The direction during the south-west monsoon is generally more southerly near the land than over the open sea. The surface current during the south-west monsoon almost invariably sets off the land to the eastward and north-eastward, and it sometimes attains the velocity of 80 to 100 miles in the 24 hours. In the north-east monsoon the conditions are generally much quieter, but the monthly charts show interesting and important differences; and the work, embracing, as it does, the whole twelve months, illustrates very fully the changes which occur, and afford very valuable material both for the man of science and the sailor.

## NOTES.

THE President and Council of the Royal Society have recommended Prof. Charles Lapworth and Prof. A. W. Rücker for the Royal Medals this year, and the Queen has signified her approval of the award. The other medallists are Prof. Cannizzaro for the Copley Medal, and Prof. Victor Meyer for the Davy Medal.

THE following is the list of names recommended by the President and Council of the Royal Society for election into the Council for the year 1892, at the anniversary meeting on November 30:—President: Sir William Thomson. Treasurer: John Evans. Secretaries: Prof. Michael Foster, Lord Rayleigh. Foreign Secretary: Sir Archibald Geikie. Other Members of the Council: Captain William de Wiveleslie Abney, William Thomas Blanford, Prof. Alexander Crum Brown, Prof. George Carey Foster, James Whitbread Lee Glaisher, Frederick Duane Godman, John Hopkinson, Prof. George Downing Liveing, Prof. Joseph Norman Lockyer, Prof. Arthur Milnes Marshall, Philip Henry Pye-Smith, William Chandler Roberts-Austen, Prof. Edward Albert Schäfer, Sir George Gabriel Stokes, Prof. Sydney Howard Vines, General James Thomas Walker.

WE are glad to hear of a splendid gift which has just been formally accepted by the Regents of the Smithsonian Institution. It is a gift of 200,000 dollars, which has been presented to the Institution by Mr. Thomas Hodgkins, of Setauket, Long Island. The donation is accompanied with a condition—which, as the *New York Tribune* remarks, "will not be onerous"—that the donor shall have the option of giving another sum of 100,000 dollars within the year. Mr. Hodgkins has arranged that the interest of 100,000 dollars shall be "permanently devoted to the increase and diffusion of more exact knowledge in regard to the nature and properties of atmospheric air."

THE opening meeting of the seventy-fourth session of the Institution of Civil Engineers was held on Tuesday, and was very fully attended. Awards were made for various original communications submitted during the past session, for various papers printed in the Proceedings without being discussed, and for various papers read at the supplemental meetings of students. Mr. George Berkley, the President, delivered an address, taking as his subject the advance of engineering work in relation to social progress.

THE following, briefly stated, are prize subjects recently proposed by the Dutch Academy of Sciences, at Haarlem:—(1) Molecular theory of internal friction of gases departing from Boyle's law, and if possible, of liquids. (2) Determination of the duration of electric vibrations in various conductors. (3) Try inoculation of *Viscum album* on apple, pear, chestnut, and lime trees, and explain its preference for certain species. (4) Criticism of opinions on structure and mode of growth of the cell-wall, having regard to continuity of the protoplasm of the adjacent cells (in some cases). (5) New experiments on the reproductive power of parts of plants, and the polarity observed in it. (6) Study of the low organisms appearing (usually as filaments) in bottles containing solutions of chemical products, after long standing. (7) Significance of peptones for the circulation of nitrogen in plants. (8) Oxidation of ammoniacal salts in the ground, and transformation into nitrates. Do the microbes found by Winogradsky and Frankland exist in the soil of Holland? (9) Researches on the organism concerned in production of marsh gas, or the conditions in which the gas is formed, if life has only an indirect influence on the phenomenon. Liberation of the gas from manure. (10) Study of the

microbes involved in ensilage of green fodder, and of the variations of sugar and acidity with temperature and time. (11) The development of Tricladæ. (12) The development of the spleen. The prize offered in each case is a gold medal or a sum of 150 florins. Memoirs may be written in Dutch, French, English, Latin, Italian, or German (not German characters), and they are to be sent in, with sealed packet, to the secretary before January 1, 1893. (Further particulars in the *Revue Scientifique*, October 10, 1891.)

ACCORDING to an official report which reached the Japanese Legation, London, on November 6, the earthquake of October 28 affected the prefectures of Aichi and Gifu. It was calculated that the number of persons killed was 6500, and of persons injured 9000; that 75,000 houses were destroyed, and 12,000 damaged.

In its review of the weather during October, the U.S. Pilot Chart notes that the latter part of September and nearly the entire month of October were characterized by exceptionally severe weather in the North Atlantic. Tropical hurricanes passed north between Hatteras and Bermuda on October 3, 12, and 18. The heavy weather that prevailed between Newfoundland and the British Channel in the last week of September was followed by comparatively moderate weather during the first two days of October, but a storm that apparently moved eastward in high latitudes on the 2nd and 3rd caused increasing westerly gales in mid-ocean, and the force of these gales was very greatly increased by the formation of a secondary on the 4th, a short distance west of Rockall. This secondary remained central about the same place for three days, the 4th, 5th, and 6th, and during all of this time there was very severe weather almost all the way from the North Sea to the Grand Banks. There were also later storms, and altogether, when the facts are fully known, it will probably be found that the month was one of the most severe on record.

WE take from *Symons's Monthly Meteorological Magazine* for October the following interesting details of the climate of the British Empire during 1890. The tables for the year exhibit some exceptional features. For the first time in the 17 years that the figures have been published, the highest shade-temperature occurred at an East Indian station, 105°·6 at Calcutta, instead of in Australia. The highest sun-temperature was, however, recorded at Adelaide, 163°·9, although it is not exceptional for this to occur at Calcutta, while the mean temperature of the East Indian stations far exceeds that of Australia. The lowest shade-temperature occurred, as usual, at Winnipeg, -39°·4, the extreme rigour of whose winters far exceeds the cold at the other Canadian stations. The greatest range in the year, 135°·9, as well as the greatest mean daily range and the lowest mean temperature, 32°·8, also occurred there; while the least yearly range, 25°·4, and the highest mean temperature, 80°·5, occurred at Colombo, Ceylon. The driest station was Adelaide, mean humidity 62, and the dampest London, mean humidity 80. The greatest rainfall for the places quoted was 82·90 inches at Trinidad, and the least, 19·96 inches at Jamaica. The most cloudy station was Hobart, in Tasmania, and the least cloudy Malta. A large amount of cloud occurs at most insular stations, as well as great humidity, and small range of temperature; and, at one time or another London, Ceylon, Barbados, and Mauritius have recorded the extremes of most of these elements.

AT the distribution of prizes in the Sheffield Technical School last week, Dr. [Sorby, the President of the Council of Firth College, spoke vigorously and opportunely on a subject which is likely to become one of increasing importance—the true relation of technical education to the study of pure science. He feared, he said, not that technical education would not succeed, but that the public might forget that there might be something else

besides. He hoped that in the efforts that were being made to insure education in everything which was required for the trade of the country they would not forget that there were other things besides that. Some of the greatest discoveries made by Davy, Faraday, and Pasteur, were not made for trade purposes, but in the interests of abstract science. If they did anything to delay the development of science as a whole, they would hinder trade in the long run. Abstract science might sometimes appear at first to be very abstract, but all at once it might turn out to be of the utmost value in connection with trade. He would be very sorry indeed if in the future technical instruction should push other education out of the field altogether. There was a danger of this, because the funds available for education and objects of that kind were limited, and what was devoted to one institution was to some extent taken from others.

THE annual report on the technological examinations of the City and Guilds of London Institute has just been published. It is signed by Mr. G. Matthey, F.R.S., chairman of the examinations committee, and Sir Philip Magnus, superintendent of technological examinations. The facts set forth in the report are, upon the whole, satisfactory. At the recent examination the total number of worked papers was 7416, as against 6781 in 1890, showing an increase of 635, the corresponding increases in the two previous years being 175 and 440. This year, too, there is not only an increase in the number, but also in the proportion of candidates who have succeeded in satisfying the examiners, the number of passes being 4099 as against 3507 in 1890, and the percentage of passes 55·3 as against 51·8. Moreover, the examinations were held this year in 53 as against 49 subjects in the previous year, and in 245 as against 219 different centres throughout the country.

WRITING to the *Times* on the place due to horticulture in technical education, Mr. W. Wilks, honorary secretary of the Royal Horticultural Society, says that that Society is ready to co-operate with the County Councils in any attempt to promote the serious study of the subject. The Society has already entered into arrangements with the County Council of Surrey for holding examinations and awarding certificates, &c., after a series of lectures in various centres; and the County Council of Cambridgeshire is in communication with the Society as to the provision of practical demonstrations of scientific methods applied to orchards, allotments, and cottage gardens. Mr. Wilks is also in correspondence with a gentleman in Somersetshire, with the object of sending round an itinerant instructor and adviser to some of the cider orchard districts of that county.

AT a meeting of the Ashmolean Society in the Museum, Oxford, on Monday, November 9, under the presidency of Prof. Odling, Colonel Swinhoe read a paper on silk-producing moths. The author exhibited specimens of *Bombyx mori* and of their cocoons, showing the changes produced by variation of climate and domestication on members belonging to the Bombycidae. Several specimens of the tussur silkworm were exhibited, illustrating in some respects the effects of cross-breeding, which, in the opinion of the author, had done much to depreciate the commercial value of the silk produce of India. Much greater care—a care which the Chinese appreciated—was needed on the part of the native breeders of the silkworm to insure in the silk the peculiar qualities which enhance its market value. A discussion followed, in the course of which Prof. Legge described briefly the method of culture of the mulberry-tree in China, and some of the methods employed in winding and securing the silk.

THE Christmas lectures to juveniles, at the Royal Institution, will this year be on "Life in Motion, or the Animal Machine" (experimentally illustrated), and will be delivered by Prof. John G. McKendrick, F.R.S., Professor of Physiology in the University of Glasgow.



A MAMMALIAN tooth has just been discovered by Mr. Charles Dawson, of Uckfield, in a Wealden bone-bed near Hastings. The fossil much resembles one of the lower molars of *Plagianax*, a genus well known from the Purbeck Beds of Swanage. It is the first evidence of a mammal from the Wealden formation, and will be exhibited and described by Mr. Smith Woodward at the next meeting of the Zoological Society, on the 17th inst.

DE CANDOLLE states, in his "Origin of Cultivated Plants," that maize is unknown in the wild condition. Some light may possibly be thrown on the origin of cultivated maize, by the discovery of a wild species, the only one of the genus, in Mexico. It is described by Prof. Sereno Watson, in the "Contributions to American Botany," under the name *Zea nana*.

WE learn from the *Journal of Botany* that the great Index of Genera and Species of Flowering Plants, on which Mr. B. Daydon Jackson has been continuously engaged for nearly ten years, is now ready for the printers' hands, and will be issued by the Clarendon Press, under the title "Index Kewensis nominum omnium plantarum phanerogamarum, 1735-1885." The work has been carefully revised by Sir Joseph Hooker, who, besides annotating the manuscript, has undertaken the care of the geographical distribution.

If the weather during the approaching winter be as severe as that which we had last winter, many persons will be likely to take some interest in an invention which is attracting notice in America. This is an electric snow-sweeper—a snow-sweeper driven by an electric motor. The *Engineering Magazine*, of New York, says that while the machine is driven along the track of an electric railway by a motor of 30 horse-power, taking its current through the trolley wire, the two sweeping brushes are each driven by an independent motor, and all the three motors are reversible. It is stated that this plough is competent to remove from a track snow having a depth of from 3 to 12 inches, while running at a speed of from 4 to 10 miles an hour. The independent action of the brush-motors enables them, when necessary, to be run at a high rate of speed while the plough is moved slowly along the track, and thus to cut away hard, compacted snow, or drifts. It is said that the machine was thoroughly tested last winter, and its effectiveness thereby completely demonstrated.

It is known that ozone can be abundantly produced by the electric silent discharge, and many years ago Siemens devised an "ozone-tube" for the purpose, consisting of two thin glass tubes, one within the other; the inner lined, and the outer coated, with metal, to which alternating currents of high tension are brought, acting on the gas to be ozonized within. From recent experiments in Siemens and Halske's laboratory, it appears that a good result may be had with only one dielectric, and for this not only glass, but mica, celluloid, porcelain, or the like, may be used. Thus the ozone-tube may be arranged with a metallic tube within, and the outer tube a metal-coated dielectric; or the inner metal tube may have a dielectric coat, while a metal tube is the inclosing body. As metals that are little or not at all attacked by ozone, platinum, tin, tinned metals, and aluminium are recommended. Through the inner tube flows cold water, and through the space between the tubes air, dried and freed from carbonic acid. Several such tubes may be combined in a system, and worked with alternate currents (for single tubes the continuous current with commutator is best). An apparatus of this kind is now at work in the laboratory, yielding 2.4 mg. of ozone per second. Experiments are being made in supplying compressed ozone for technical use; and this has been accomplished with a pressure of nine atmo-

spheres. One use of ozone, on which Herr Frölich lays special stress (in the recent lecture from which these data are taken), is the disinfection and sterilization of water. And doubtless with an abundant supply of the substance, the use of it would be greatly extended.

MR. A. CRAWFORD, the manager of the travelling dairy connected with the Department of Agriculture, Victoria, is able to give a very favourable report of the results of the operations of the dairy during the last two years. It has been the means, he says, of very largely improving the general average of both cheese and butter sent to market. A good many pupils have been taught who had never made butter of cheese before, and several of them are now managing factories. In nearly all the places he has visited Mr. Crawford has lectured on dairy farming; and in many cases he has gone to outlying districts as well as to important centres.

AT the recent general meeting of the German Anthropological Society, Prof. Montelius, of Stockholm, delivered two remarkably interesting archaeological lectures. In the first he dealt with the chronology of the Neolithic Age, especially in Scandinavia. The monuments of that age, he said, belonged to three different periods. First, were free-standing dolmens without passages; next, passage-graves; finally, stone cists. The last are later in proportion to the completeness with which they are covered by the mounds heaped over them. Behind the periods represented by these classes of monuments was a Neolithic period from which no grave of any kind is known to have survived. It has left traces, however, in its implements, which are of an earlier form than the various sorts found in the different groups of monuments. The Scandinavian forms of Neolithic weapons, implements, and ornaments are closely akin to those which have come down to us in the rest of Europe, especially in North Germany, England, Italy, and even Cyprus. This may be held to prove that there was a more or less active commercial intercourse between Scandinavia and the Continent at a very remote time. To this commercial intercourse Prof. Montelius is disposed to attribute the relatively high civilization of Scandinavia in the Neolithic Age. Prof. Montelius also contends that the various periods of the Neolithic Age in Scandinavia were more nearly contemporaneous with those of other parts of Europe than has hitherto been generally supposed.

In his second lecture Prof. Montelius treated of the Bronze Age in the East and in Southern Europe. He distinguished the following periods:—(1) A copper period without bronze, represented by the finds of Richter in Cyprus and those obtained by Schliemann from the first city at Hissarlik. (2) The bronze period in the islands of the Ægean Sea, Rhodes, Crete, &c. (3) A later bronze period—(a) with shaft tombs at Mycenæ, (b) with bee-hive tombs in the neighbourhood of Mycenæ, Orchomenos, &c. These cities had not a pure Hellenic civilization, but must be regarded rather as Oriental colonies. The knowledge of bronze certainly came to Europe from the East; not by way of Siberia and Russia, nor across the Caucasus, but probably through Asia Minor and the Mediterranean to Italy and Spain, whence it rapidly spread to Gaul, Britain, and other countries.

A PENINSULA called Keweenaw Point, jutting into Lake Superior from the southern shore towards the north-east, is famous as the centre of a vast copper-mining industry. Last year the mines produced no less than 105,586,000 pounds of refined copper, and it is estimated that during next year production will be increased by at least 20 per cent. Mr. E. B. Hinsdale, who contributes to the latest Bulletin of the American Geographical Society an article on the subject, has much that is interesting to say about the numerous prehistoric mines which have been found in this region. These ancient mines—judging

from their extent—must have been worked for centuries. Who the workers were, no one can tell. They seem to have known nothing of the smelting of copper, for there are no traces of molten copper. What they sought were pieces that could be fashioned by cold hammering into useful articles and ornaments. They understood the use of fire in softening the rocks to enable them to break away the rock from the masses of copper. They could not drill, but used the stone hammer freely. More than ten cart-loads of stone hammers were found in the neighbourhood of the Minnesota mine. In one place the excavation was about 50 feet deep, and at the bottom were found timbers forming a scaffolding, and a large sheet of copper was discovered there. In another place, in one of the old pits, was found a mass of copper weighing 46 tons. At another point the excavation was 26 feet deep. In another opening, at the depth of 18 feet, a mass of copper weighing over 6 tons was found, raised about 5 feet from its native bed by the ancients, and secured on oaken props. Every projecting point had been taken off, so that the exposed surface was smooth. Whoever the workers may have been, many centuries must have passed since their mines were abandoned. Their trenches and openings have been filled up, or nearly so. Monstrous trees have grown over their work and fallen to decay, other generations of trees springing up. When the mines were rediscovered, decayed trunks of large trees were lying over the works, while a heavy growth of live timber stood on the ground.

The last two parts of the *Investia* of the Russian Geographical Society (vol. xxvii., 3 and 4) contain M. Grum-Grzimaïlo's report on his journey to Central Asia, and General Tillo's calculations of the heights determined by the Russian traveller during his journey. The report, which adds little to the information given in the explorer's letters, is accompanied by a map embodying the results of the extensive surveys made by the two brothers in the Eastern Tian Shan, the Hashun Gobi, the Barkul oasis, and the region in the south-east of it, as far as the 36th degree of latitude and the 72nd degree of longitude. It was already known that during this journey the brothers Grum-Grzimaïlo had discovered, some fifty miles to the south-east of Turfan, a depression situated between the two chains of the Eastern Tian Shan and the Kuruk-tag Mountains, the level of which proved to be very near to the sea-level, or even below it. At the spot, Lukchin-chir, their barometer rose (on October 27) to 771.7 mm. On the same day, the pressure of the atmosphere, reduced to the sea-level, attained 784 mm. at Krasnoyarsk, 787.7 mm. at Yeniseisk, 774 mm. at Irkutsk and Tomsk, and 767 mm. at Przevalsk and Narynsk; so that there may be some doubt as to the pressure in the latitude and longitude of Lukchin-chir (at the sea-level) really being 767 mm., as adopted by General Tillo, which would give for that spot 50 metres below the level of the sea. But the possible error cannot be very great, and we thus have, between the two above-named chains of mountains, an undoubted depression, the surface of which is very near to the level of the ocean.

MR. L. STEJNEGER describes, in the Proceedings of the American National Museum, a new North American lizard of the genus *Sauromalus*. It is very large, the total length of four specimens averaging 540 millimetres. This enormous lizard is closely allied to the much smaller species which inhabits the arid regions of the mainland to the north of the Gulf of California, viz. *Sauromalus ater*, with which it has been confounded. It may be readily distinguished by the characters given in Mr. Stejneger's diagnosis.

SOME time ago the Educational Museum of Tokyo was abolished, and the collections were transferred to the Science College of the Imperial University. Dr. I. Ijima, Professor of Embryology and Comparative Anatomy, who volunteered to

take care of the ornithological collection, offered to send it to Mr. L. Stejneger, of the U.S. National Museum, in instalments for identification and study, and the proposal was gladly accepted. Dr. Stejneger has made some progress with the work, and has just issued "Notes" in which he presents the results of his examination of the first instalment. He has had the satisfaction of finding "quite a number of interesting additions to the Japanese avifauna."

WE have received Nos. 7-9 of vol. i. of "Illustrations of the Flora of Japan, to serve as an Atlas of the Nippon-Shokubutsu-shi," by Tomitaro Makino, a monthly publication, brought out in Tokyo, apparently somewhat on the plan of the "Icones Plantarum." Each number contains about six plates (un-coloured), with descriptions, of new or remarkable species, natives of Japan. The drawings are exceedingly well done, and the descriptions (in English) would compare favourably, in accuracy and completeness, with those of some works published in this country. The species described appear to be taken at random, those in the same number having no affinity with one another.

MESSRS. BAILLIÈRE, TINDALL, AND COX have issued the fifth edition of the "Manual for the Physiological Laboratory," by V. D. Harris and D'Arcy Power. The work has been enlarged, the increase being due mainly to the more detailed account which has been given, for junior students, of microscopes and their properties; and to the description, for senior students, of the latest methods of histological research. The parts relating to physiological chemistry have been thoroughly revised, and many additional illustrations have been inserted.

MR. JAMES STIRLING, Assistant Government Geologist, Victoria, has published at Melbourne some valuable and interesting notes on the hydrology of the Mitta Mitta. The following are the leading conclusions to which he has been led by his observations:—(1) That there is considerable inequality in the amount of rainfall over different portions of the same watershed area in each of the various streams flowing from the Australian Alps, the Mitta Mitta being cited as an instance of this; and that as the recording stations at present established are all below the normal line of cloud flotation (under 4000 feet), where the rainfall is greater, the actual quantity which falls in the several watershed areas is really greater than that shown in the records. (2) That the low percentage of discharge to rainfall is due in all probability to a complexity of causes, among which may be cited the excessive evaporation in certain areas, largely due to the great range of temperature; the different heat-radiating powers of different rock-masses; and percolation along fault lines, contacts of the igneous and sedimentary formations, &c.; and, in some areas, the absorption by certain species of the prevailing eucalyptus vegetation. (3) To determine the actual quantity of rainfall and the causes affecting its local distribution, it has become necessary to establish meteorological stations at the higher altitudes in the Australian Alps. (4) And in order to supply further trustworthy data, it is, Mr. Stirling thinks, imperative that a system of complete topographical survey should be instituted.

THE Annual Report, for 1888-89, of the Geological and Natural History Survey of Canada has been issued. It forms the fourth volume of the new series, and includes reports and maps of various investigations and surveys. The volume opens with summary reports, by Mr. Alfred R. C. Selwyn, the Director, on the operations of the Geological Survey for the year 1889. Then come the following reports:—On a portion of the west Kootanie district, British Columbia, by G. M. Dawson; an exploration in the Yukon and Mackenzie basins, by R. G. McConnell; exploration of the glacial Lake Agassiz in Manitoba,

by Warren Upham; the mineral resources of the province of Quebec, by R. W. Ellis; the surface geology of Southern New Brunswick, by R. Chambers; chemical contributions to the geology of Canada from the laboratory of the Survey, by G. C. Hoffmann; mining and mineral statistics of Canada, by H. P. Brumell; division of mineral statistics and mines, by E. D. Ingall and H. P. Brumell; annotated list of the minerals occurring in Canada, by G. C. Hoffmann.

The administration of forests seems to be, on the whole, one of the most satisfactory departments of public activity in India. Dr. Ribbentrop, in his report for the year 1889-90, states that over 4200 square miles were added to the area of forest estates under control, thus bringing the total area up to nearly 105,500 square miles. The gross revenue exceeded 153 lakhs of rupees, giving a surplus over expenditure of nearly 73 lakhs, or an increase in a single year of 15 lakhs. The surplus in 1885 was only 41 lakhs. It is believed that this rate of increase may be maintained, as the rich forests of Upper Burma have still to be opened out.

In a recent communication from Alta Verapaz, a department in Guatemala (*Met. Zeit.*), Dr. Sapper describes the climate. The position is on the north slope of a hill-range stretching east and west, and the large rainfall (it has a rainy season in winter, as well as that in summer common to the whole of Central America) apparently affects the frequency of earthquakes. For the district is of limestone and dolomite, and honeycombed with caverns and subterranean watercourses, and heavy rains lead to a collapse of such cavities, so that towards the end of the summer rain season, and still more towards that of winter, the number of earthquakes and tremors is distinctly increased. The winter of 1889-90 had unusually heavy rains, and the earthquakes were also unusually numerous (seventeen in 1890 as against five the previous year).

A PAPER upon the sulphides of boron is communicated by M. Paul Sabatier to the September number of the *Bulletin de la Société Chimique*. Hitherto only one compound of boron with sulphur has been known to us, the trisulphide,  $B_2S_3$ , and concerning even that our information has been of the most incomplete description. Berzelius obtained this substance in an impure form by heating boron in sulphur vapour, but the first practical mode of its preparation in a state of tolerable purity was that employed by Wöhler and Deville. These chemists prepared it by allowing dry sulphuretted hydrogen gas to stream over amorphous boron heated to redness. Subsequently a method of obtaining boron sulphide was proposed by Fremy, according to which a mixture of boron trioxide, soot, and oil are heated in a stream of the vapour of carbon bisulphide. M. Sabatier finds that the best results are obtained by employing the method of Wöhler and Deville. The reaction between boron and sulphuretted hydrogen only commences at red heat, near the temperature of the softening of glass. When, however, the tube containing the boron becomes raised to the temperature, boron sulphide condenses in the portion of the tube adjacent to the heated portion; at first it is deposited in a state of fusion, and the globules on cooling present an opaline aspect. Further along the tube it is slowly deposited in a porcelain-like form, while further still the sublimate of sulphide takes the form of brilliant acicular crystals. The crystals consist of pure  $B_2S_3$ ; the vitreous modification, however, is usually contaminated with a little free sulphur. Very fine crystals of the trisulphide may be obtained by heating a quantity of the porcelain-like form to  $300^\circ$  at the bottom of a closed tube whose upper portion is cooled by water. The crystals are violently decomposed by water, yielding a clear solution of boric acid, sulphuretted hydrogen being evolved. On examining the porcelain boat in which the boron had been placed, a non-volatile

black substance is found, which appears to consist of a lower sulphide of the composition  $B_2S$ . The same substance is obtained when the trisulphide is heated in a current of hydrogen; a portion volatilizes, and is deposited again further along the tube, while the residue fuses, and becomes reduced to the unalterable subsulphide  $B_2S$ , sulphuretted hydrogen passing away in the stream of gas.

Two selenides of boron,  $B_2Se_3$  and  $B_4Se$ , corresponding to the above-described sulphides, have also been prepared by M. Sabatier, by heating amorphous boron in a stream of hydrogen selenide,  $H_2Se$ . The triselenide is less volatile than the trisulphide, and is pale green in colour. It is energetically decomposed by water, with formation of boric acid and liberation of hydrogen selenide. The liquid rapidly deposits free selenium, owing to the oxidation of the hydrogen selenide retained in solution. Light appears to decompose the triselenide into free selenium and the subselenide  $B_2Se$ .

SILICON SELENIDE,  $SiSe_2$ , has likewise been obtained by M. Sabatier by heating crystalline silicon to redness in a current of hydrogen selenide. It presents the appearance of a fused hard metallic mass incapable of volatilization. Water reacts most vigorously with it, producing silicic acid, and liberating hydrogen selenide. Potash decomposes it with formation of a clear solution, the silica being liberated in a form in which it is readily dissolved by alkalis. Silicon selenide emits a very irritating odour, due to the hydrogen selenide which is formed by its reaction with the moisture of the atmosphere. When heated to redness in the air it becomes converted into silicon dioxide and free selenium.

THE additions to the Zoological Society's Gardens during the past week include a Macaque Monkey (*Macacus cynomolgus* 8) from India, presented by Mr. G. E. Lidiard; two Senegal Touracou (*Corythæus persa*), a Madagascari Porphyrio (*Porphyrio madagascariensis*) from West Africa, presented by Mr. J. B. Elliott; a Blue-fronted Amazon (*Chrysotis æstiva*) from Brazil, presented by Mrs. H. R. Warmington; two Puff Adders (*Vipera arietans*) from South Africa, presented by Messrs. Herbert and Claude Beddington; two Tree Boas (*Corallus hortulanus*) from St. Vincent, W.I., presented by H.E. the Hon. Sir Walter F. Hely Hutchinson, K.C.M.G.; a Tree Boa (*Corallus hortulanus*) from Demerara, presented by Mr. J. J. Quelch, C.M.Z.S.; a Black-headed Lemur (*Lemur brunneus*) from Madagascar, a Brown Capuchin (*Cebus fatuellus*) from South America, a Black-headed Caique (*Caica melanocephala*) from Demerara, a Red and Blue Macaw (*Ara macao*) from Central America, deposited; and a Black-headed Caique (*Caica melanocephala*) from Demerara, purchased.

#### OUR ASTRONOMICAL COLUMN.

OUTBURST OF DARK SPOTS ON JUPITER.—Attention has been called by several observers to a number of dark spots which have appeared lately on the first belt north of the north equatorial belt of Jupiter, in about latitude  $20^\circ$ . Mr. Denning derived a period of rotation of 9h. 49m. 27.2s. from his observations of one of these objects between August 21 and September 15 (*Observatory*, October 1891). A change then occurred, for this spot, and others near it, were found to have a rotation period of 9h. 49m. 44.2s. from September 15 to October 15. This sudden change of 17 seconds in the rate of motion of a region of some extent is most remarkable. A series of photographs of Jupiter were taken at Lick Observatory in August, which, according to Mr. Stanley Williams, "are of such a degree of excellence that an examination of them is almost like looking at the planet itself" (*Observatory*, November 1891). These photographs show six or seven dark spots, and a comparison of them with a sketch made about one rotation later clearly indicates a displacement of the spots with reference to the great red spot,

owing to the more rapid movement of the belt in which they occur. Prof. E. E. Barnard observed the spots so early as May last (*Astronomische Nachrichten*, No. 3063). He found in September that they were decreasing their longitudes about 10° daily. At this rate they would describe a complete rotation round Jupiter, relative to the great red spot, in about 36 days. The daily loss derived from Mr. Denning's observations in August and September would bring the two spots in conjunction in about 39 days.

**WOLF'S PERIODIC COMET.**—The following ephemeris is from one given by Dr. Thraen in *Astronomische Nachrichten*, No. 3064:—

Ephemeris for Berlin Midnight.				
1891.	Right Ascension.	Declination.	Brightness.	
	h. m. s.	° ' "		
Nov. 14 ...	4 35 16 ...	- 8 29 28 ...	10.2	
" 17 ...	33 27 ...	9 36 16 ...		
" 20 ...	31 31 ...	10 36 44 ...	9.3	
" 23 ...	29 31 ...	11 30 38 ...		
" 26 ...	27 31 ...	12 17 51 ...	8.3	
" 29 ...	25 31 ...	12 58 22 ...		
Dec. 2 ...	23 37 ...	13 32 15 ...	7.4	
" 5 ...	21 48 ...	13 59 40 ...		
" 8 ...	20 8 ...	14 20 51 ...	6.5	
" 11 ...	18 39 ...	14 36 10 ...		
" 14 ...	17 22 ...	14 45 59 ...	5.7	
" 17 ...	16 17 ...	14 50 41 ...		
" 20 ...	15 26 ...	14 50 38 ...	4.9	
" 23 ...	14 49 ...	14 46 14 ...		
" 26 ...	4 14 27 ...	14 37 52 ...	4.3	

Although the comet is getting fainter and moving south, it may probably be followed to the last date in the above ephemeris with instruments of moderate aperture. The greatest southern declination of 14° 51' 8" is reached on November 18.

**THE TOTAL LUNAR ECLIPSE OF NOVEMBER 15.**—If atmospheric circumstances permit, a total eclipse of the moon may be observed over all Europe on Sunday next, November 15. The following are the times of contact with the earth's shadow given in the *Nautical Almanac*:—

	G.M.T.
	h. m.
First contact with the penumbra ...	9 36.7
" " " shadow ...	10 35.1
Beginning of total phase ...	11 37.4
Middle of eclipse ...	12 18.9
End of total phase ...	13 0.4
Last contact with the shadow ...	14 2.7
" " " penumbra ...	15 1.1

The first contact with the shadow occurs at 55° from the most northern point of the moon's limb counting towards the east, the last contact at 95° from the same point counting towards the west.

**THE ELEMENTS OF THE MINOR PLANETS.**—The *Vierteljahrsschrift der Astronomischen Gesellschaft* (first volume) contains two interesting compilations, on the planets discovered in the year 1890, and on the appearances of comets in the same year. The first paper is contributed by Dr. Paul Lehmann, and informs us that no less than fifteen new members of our minor planet system were discovered last year between February 20 and November 14. In the table that follows a summary of all the days on which each individual planet was observed is given, and this is succeeded by another which shows their chief elements. By combining the elements of some of the old planets with those of the new ones, some striking combinations are thus brought to light, of which we give the two following cases, in which the new planets are 292 and 288:—

Planets.				
152	$\Omega = 41.3$	$i = 12.2$	$\phi = 4.4$	$a = 3.15$
13	43.2	16.5	5.0	2.58
99	42.0	13.9	13.8	2.80
155	43.1	14.1	14.8	2.91
292	43.1	14.7	2.4	2.53
268	$\Omega = 121.7$	$i = 2.0$	$\phi = 7.9$	$a = 3.09$
288	121.6	4.4	11.6	2.75
113	123.1	5.0	5.0	2.38
213	122.4	6.8	8.3	2.75

The next table shows the values that have been obtained after computing the mean brightest and darkest magnitudes that the

planets can attain. In the last form the tabulation is so arranged that the following numbers can be directly seen:—(1) The number of oppositions in which, up to the present time, places have been found, with the number of appearances since observed. (2) The number of every known opposition in which the planet has been observed. (3) Every planet to which the foregoing statement refers. (4) The number of these planets.

### SOME EXPERIMENTS MADE WITH THE VIEW OF ASCERTAINING THE RATE OF PROPAGATION OF INDUCED MAGNETISM IN IRON.

THE question, considered in a simple form, may be put thus: Suppose a magnet were suddenly brought up to one end of a long iron rod, what length of time intervenes between the occurrence of magnetization at the near end and at the far end?

Everyone, probably, would at first be inclined to say that the speed along the bar would undoubtedly be about the same as the velocity of light, and this supposition would naturally follow if the energy to places along the bar be supposed transmitted through the surrounding space; but, on the other hand, the speed may be much less if the energy of magnetization is transmitted from particle to particle in the iron—the orientation of the molecular magnets being, as it were, passed from each to the next along the bar. In such case we would, of course, expect the velocity of propagation to be comparable in speed with that of molecular phenomena rather than that of disturbances in the ether.

The velocity of sound, with which we may, perhaps, compare it, is in iron about 16,000 feet per second. The transmission of sound resulting from vibratory movement can be said to depend on the mass of the molecule, and on the mutual forces keeping the molecules in position; while the rate of propagation of a magnetic disturbance of the kind supposed would depend on the moment of inertia of the particles (assumed to be molecular magnets) round their axes of rotation, and on their mutual magnetic moments.

The propagation of such a disturbance can be observed in Prof. Ewing's magnetic model. The model, which consists essentially of a great number of small compass needles placed within each other's action, but not near enough to touch, can be disturbed at one place by bringing a magnet near, or otherwise. The disturbance then is seen to spread throughout the model, much in the same manner as we have suggested a magnetizing disturbance to be propagated in iron.

The method proposed to test matters depended upon the principle of the interference of waves travelling in opposite directions observed through the production of stationary waves.

Thus, if a bar of soft iron have two coils of wire placed one at each end, and if the same alternating current be passed through both coils, disturbance of opposite signs travelling in opposite directions along the bar should interfere, provided the rate of alternation and the length of the bar are chosen suitable to the rate of propagation.

It was proposed to detect the nodes or places of interference by means of a telephone in circuit with a third coil which could be slid along the bar.

Instead of employing two alternating coils, the bar can be bent round to form a ring, and one coil will be then sufficient.

Some preliminary experiments with a straight bar having given faint indications of the existence of places of minimum intensity, closed magnetic circuits or rings, formed of a great number of turns of soft iron wire,<sup>1</sup> were then tried with more decided results. When the alternating coil was in certain positions on the ring the telephone coil could be placed at points where no sound, or if any very slight, could be heard—the sound reaching a maximum in places somewhere between these points. These nodes and inter-nodes occupied about half the ring—the opposite half of the ring from that in which the alternating coil lay. On approaching nearer the alternating coil, apparently the very unequal length of the paths prevented any effect being observed.

It was without difficulty ascertained that these were not the

<sup>1</sup> Two rings were made of No. 21 soft iron wire, one about 10 feet and the other 14.5 feet in circumference. Both had 8 pounds of wire wound on. The wire used in a third ring was No. 32. This ring was about 12 feet in circumference. There was about a mile of wire put on. The wire of this and the 14-foot ring was well coated with shellac before winding, so as to minimize Foucault currents.

nodes looked for, because the distances between them remained unaffected on changing the rate of alternation. The distances from node to node also were found to measure different amounts (though on the whole there was a decided tendency towards regularity). The average distance apart of the nodes in the different rings tried lay between 10 and 18 inches.

The occurrence of the nodes might have been very well attributed to the ring being locally irregular in its susceptibility to induction, but for the irreconcilable fact that the effects on either side of a node were found to be of opposite phase, just as it would be, were the phenomenon due to stationary interference waves.

This was ascertained by means of two coils connected in the same sense in series with the telephone. When these coils were arranged at places of equal intensity, one on each side of a node, no sound was to be heard in the telephone, the effects neutralizing one another. A commutator, to throw in the coils singly or together as desired, is convenient for making this experiment.

From this, one would naturally assume that the currents induced on either side of a node must be of opposite sign, seeing that they neutralize each other in the telephone; but experiments with the galvanometer show it not to be the case. To test this, the galvanometer is connected up through a commutator arrangement fixed to the originator of the primary current in such a way as only to admit of the currents induced in one direction passing. Tried in this way, no difference in the direction of the current on either side of a telephone node was found, or, indeed, any trace of a minimum effect at these points. The thing can also be tested by means of a ballistic galvanometer, and a reversing key with battery, for, with a reversing key and telephone, the nodes, which are quite independent of the speed, are to be found, as well as the opposite phase effect. The ballistic galvanometer gives no indication of there being any difference at the nodes from elsewhere, and the deflection everywhere is in the same direction.

It was thought that perhaps the telephone effect was in some way connected with the fact that the form of the alternating current was not a simple wave or sign curve, owing to the method employed in producing it. This consisted of a rotating commutator, which threw in circuit alternately two cells connected up singly and in opposite directions. For this reason, the effect, when using a small alternating machine with about 40 alternations per second, was compared, and was found to be in no way different. Also what must have been a very regular variable current of the simple harmonic type was procured by means of a microphone and an organ-pipe. This gave like results.

One is thus left apparently to suppose the sound in the telephone to be due to a peculiarity in the character of the curve representing the rise and fall of the current, probably something of the nature of a subsidiary oscillation; this subsidiary oscillation being absent at the nodes, and of opposite sign on either side.

As mentioned before, it is necessary for the alternating coil to be placed at definite positions, in order that the system of nodes and internodes should occur. These positions of the alternating coil are at about the same average distance apart, and are of very much the same character with respect to regularity as the nodes of the telephone coil. In fact, if the alternating coil and the telephone coil change places round the ring, the best position for the alternating coil will always be between two nodes, and the nodes will be found situated between two old positions of the alternating coil. If the alternating coil be placed at a point where a node was found in some other position of the alternating coil, the system of nodes and internodes generally completely disappears, and now on moving the telephone coil round the ring the intensity uniformly diminishes until the diameter is reached, and then increases round the other half of the ring. This gives the phenomenon a distinctly resonant character. The induced current, as observed by a galvanometer, is always of the latter character—that is to say, a uniform fall, and then a rise on going round the ring.

As a rule the permanent magnetism of these large rings is irregular, and apparently apt to change frequently. A determination of the permanent magnetism was easily made by means of one of the coils connected with a ballistic galvanometer. By moving this through a given amount at a time, say an inch, and noting the throw of the needle, one was able to plot out a representation of the state of the permanent magnetism. In this way, places where no throw occurs were found, while to either

side of such a point the throw changed sign. It was sometimes found that there was a decided tendency for the position of no throw to occur between two telephone nodes, the throw changing sign on either side of these points. But further experiments showed that this arrangement of the permanent magnetism was probably accidental, and due to the very currents employed in making the telephone observations. For when only very feeble currents had been used on a ring, these consequent poles were absent.

It is possible, as one would expect, to artificially make a minimum intensity position, at any point on a ring, by winding on a few turns of thick copper wire. But the fact that the phases on either side of such a point (found as before by means of two coils in circuit with a telephone) are the same, precludes the idea that the nodes can be due to Foucault currents.

Obviously, however, the phenomenon depends on some permanent peculiarity round the ring which happens to occur fairly regularly. What this peculiarity is, or how it is brought about, I have not yet been able to discover.

FRED. T. TROUTON.

### OYSTERS AT THE ANTIPODES.

SO much attention has been given in England to the various questions connected with oyster-fisheries that it may be of interest to note some facts relating to the oyster-fisheries of our Australian kinsfolk. The subject was admirably dealt with in a lecture delivered by Mr. Saville-Kent before the Christchurch meeting of the Australasian Association for the Advancement of Science. This lecture is entitled "Oysters and Oyster-Culture in Australasia," and has been published separately.

Mr. Saville-Kent devotes attention chiefly to Australia and Tasmania, as, at the time when his lecture was prepared, he had not had an opportunity of personally studying the question in New Zealand. Beginning with Tasmania, where for five years he was officially connected with the oyster-fisheries, he points out that the oyster of Tasmania corresponds closely with the type *Ostrea edulis*, produced and cultivated in British waters. Formerly, this oyster was so abundant in Tasmanian waters, that, according to the report of a Royal Commission of Fisheries in 1882, about twenty years previously a quantity representing at current prices a retail value of no less than £90,000 had been exported in a single year to Victoria and New South Wales. At that time, oysters were so plentiful that it was a common practice to burn them in large quantities for the purpose of making lime. The strain was, of course, too severe, and by and by the Tasmanians found that, although there was still a demand for oysters, there was no longer a home-supply, and that it was necessary for them to go elsewhere for the commodity which they had so recklessly wasted. In 1884, when Mr. Saville-Kent reached the colony, the oyster-fisheries of Tasmania had for some years been an obsolete industry. Profiting by the information which had been made accessible through the International Fisheries Exhibition and associated Conferences in London in 1883, and by Prof. Hubrecht's testimony as to the oyster-fisheries of the Schelde, Mr. Saville-Kent recommended the establishment, in suitable localities, of efficiently-protected Government reserves, upon which breeding-stocks of oysters of the best quality should be carefully cultivated and permanently retained. These reserves were to fulfil the double purpose of breeding-centres, from whence the surrounding waters might be restocked, and also of model oyster-farms, around which private beds might be established on similar lines. The scheme recommended being approved, sites formerly associated with the most prolific oyster production were selected. The operations were necessarily conducted on a very modest scale. Oyster stock, suitable for laying on the reserves, could be accumulated only by slow and laborious processes, and some 20,000 to 50,000 oysters represented the approximate numbers that were gradually collected and placed under cultivation. In order that the largest possible amount of spat produced by the oyster stocks laid down might be caught, various methods were adopted, the principle being that which has been followed with so much success by M. Coste on the west coast of France. In addition to dead oyster-shells, or "culch," which has, from the earliest days of oyster-culture, been recognized as representing a most natural and prolific catchment material for the adhesion of the spat, artificial collectors of various descriptions were introduced. In France, tiles cemented on their lower surfaces have been found

to constitute the most productive and economic collectors. In Tasmania, as in all the other Australasian colonies, tiles being much too expensive for such a purpose, a cheap and efficient substitute for them was effectually improvised out of the thin roughly-cleft boards known as "split palings," which can be produced in timber-producing districts at a cost of from 8s. to 10s. per 1000. These paling collectors are coated on their under surface with cement, a brick or stone is fastened underneath at each end to give them stability, and a wire loop secured through the centre of their upper surface forms a convenient handle by which they can be manipulated on shore or raised with a boat-hook from beneath the water.

The results have been most satisfactory. Last year oysters had become so plentiful at Spring Bay that the Hobart market was glutted, and the sale price was reduced 50 per cent. Thus an important industry has been revived, and there can be little doubt that by the due maintenance of the breeding-reserves the oyster-fisheries of Tasmania will be restored to more than their former prosperity. In accordance with Mr. Saville-Kent's recommendations, all holders of private oyster-beds in Tasmania are bound by the terms of their leases to retain a certain amount of breeding-stock—not less than 10,000 mature oysters to the acre—permanently on their oyster-beds. This regulation contributes materially towards the distribution of spat throughout the surrounding water, and to the re-establishment of the oyster-fisheries upon a durable basis.

Referring next to Victoria, Mr. Saville-Kent says that the specific form of oyster indigenous to the Victorian coast-line is a so-called mud oyster, identical with that produced in Tasmanian waters, and to all outward appearance indistinguishable from the British native, *Ostrea edulis*. In former years vast quantities of this oyster were obtained from Western Port Bay, Port Albert, and Corner Inlet. Over-dredging, however, has reduced these prolific natural beds to the very verge of extinction, so that Victoria has for many years been dependent upon New South Wales, Queensland, South Australia, and New Zealand, for her oyster supplies. Some time ago Mr. Saville-Kent was invited by the Government of Victoria to make a tour of and report upon the fisheries of the colony, giving special attention to the practicability of reviving the oyster-fisheries. As a result of that tour of inspection, he strongly recommended the adoption, at Western Port and Port Albert more particularly, of the methods which had proved so effective in Tasmania. One such reserve with a very small stock of oysters was formed at Port Albert. Unfortunately, however, the Government omitted to make provision for periodical skilled supervision, and the reserve dwindled away. As Mr. Saville-Kent says, unless such reserves can be maintained in efficient working order, and the operations periodically required thereon be supervised by a practical oyster-culturist, the money expended on their establishment is simply wasted.

At various parts of the Victorian coast-line, Mr. Saville-Kent observed considerable numbers of oyster-shells, evidently derived from deep water, that had recently been cast upon the shore by storms. He consequently predicted that more or less extensive beds would be found off the coast; and off-shore beds have in fact been since discovered. Mr. Saville-Kent points out that a most favourable opportunity is thus afforded for the restocking of the in-shore fisheries.

In New South Wales a separate species of oyster has to be taken into consideration. The commercial species of this colony is the rock oyster, *Ostrea glomerata*. At the same time a mud oyster, identical with or most closely allied to the Victorian and Tasmanian type, *Ostrea edulis*, occurs in some numbers upon the coast, but in consequence of the hitherto profuse abundance of the rock variety it has not been considered worthy of commercial attention. In form and general aspect the New South Wales rock oyster somewhat resembles the Portuguese oyster, *Ostrea angulata*, and also the American *Ostrea virginiana*. With these two species it further corresponds in its breeding habits, which are essentially distinct from those of the English, Victorian, and Tasmanian mud oyster, *Ostrea edulis*. In the case of the Australian rock oyster there is no nursing of the young brood, which is turned out to shift for itself, not only in a shell-less but even in an unfertilized condition. Like the spawn of many fishes, these ova are fertilized in the water. They can be readily fertilized artificially, and Mr. Saville-Kent has found that four days after fertilization the shells, which make their appearance on the second day, become so dense that the embryo oysters can no longer support themselves in the water, but sink

to the bottom, where they assume their permanently fixed condition. Such is the fecundity of this oyster that the rocks and every available hiding-place in the bays, estuaries, and inlets of the districts it affects become literally plastered with the embryo brood; and until quite recently, artificial culture in the scientific sense has in New South Wales been usually regarded as an unprofitable and unnecessary superfluity. Lately, however, the oyster-fisheries of the colony have been seriously damaged by a disease which either destroys the oyster or makes it unfit for food. Mr. Saville-Kent attributes this disease to the pollution of rivers. If he is right in this view, in support of which he has much to say, the oyster-growers of New South Wales will, as he says, have to make the most of the water area left to them where the water is pure. They may also have to turn their attention to the cultivation of the New South Wales variety of the mud oyster.

In Queensland, as in New South Wales, the only oyster used in commerce is the rock variety, which may be said to attain its maximum development in both quantity and quality in the Moreton and Wide Bay districts. In these areas the species is so abundant that large consignments, above those required for home consumption, are exported to New South Wales and Victoria. The disease which has so seriously depleted the fisheries of New South Wales has not yet affected the Queensland beds. Mr. Saville-Kent thinks that this immunity is probably due to the circumstance that the Queensland oyster-fisheries are chiefly located in bays and channels in close proximity to the open sea, from whence, even after heavy floods from the tributary rivers, they are speedily revived by an inflow of sea-water. He urges the Queensland authorities to preserve these tributary streams as far as possible from pollution by chemical or other noxious works, which if allowed to increase to any considerable extent cannot fail to exert a very deleterious effect upon both the oyster and all other fisheries of the bays into which the rivers flow. Artificial oyster-culture, with the exception of one or two small experiments, has been so far carried out in Queensland waters on the simple lines only of transporting the young brood or ware, locally known as "cultivation," from one locality and laying it down on ground where it will develop more speedily to maturity. Mr. Saville-Kent believes, however, that it would be profitable to use split palings as spat collectors. One advantage possessed by this form of collector is the shelter from the sun's heat afforded to the young brood when left high and dry by the receding tide. Millions of the Australian rock oyster are destroyed annually through exposure to the overpowering heat of the sub-tropical sun in the early days of their attachment to exposed rocks near high-water mark. The overhanging ledges of larger rocks and the shady sides of stone jetties or embankments are invariably found to attract and support the greatest amount of oyster brood, and this shelter, which is naturally sought, plainly indicates the lines that may be most profitably followed in operations connected with the artificial cultivation of the species.

We may note that since Mr. Saville-Kent's lecture was published a report by him on "Oysters and Oyster-fisheries of Queensland" has been issued by the Queensland Government. In this report, which is carefully illustrated, full details are given as to the conditions which must be specially taken into account by all persons connected with Queensland oyster-fisheries. Referring to the "split paling" collectors, Mr. Saville-Kent emphatically repeats what he says in their favour in his lecture. After considerable experience he expresses his conviction that they are the most convenient and economic form for use in Australian waters, and that they may be characterized as an essentially Australian product. About half-tide mark represents the zone within which—at all times of the year, but especially in the months of February and August—they gather the most abundant harvest of spat. On their first attachment to the cemented collectors, the young oysters adhere to the cement by the entire surface of the attached shell. After attaining to about half an inch in diameter, the free edges of the shells begin to grow outwards, and this direction of their growth is continued until at an age of about six months they project an inch and a-half or two inches from the collector. At this stage the young oysters may be easily detached with or without the cement, and be laid on the banks as ordinary "cultivation." The collectors may then be re-cemented and re-laid for the catchment of a second crop.

Of the oyster-fisheries of South and West Australia Mr. Saville-Kent is not able, in his lecture, to give precise details. He says,

however, that excellent oysters of fine quality and magnificent proportions, allied to *Ostrea edulis*, are exported from Spencer's Gulf in South Australia to the Victorian markets, and more especially to Ballarat. Some of these South Australian oysters are of such Broddingnagian dimensions that it is customary to cut them in four pieces for sale at the oyster saloons, the quarters thus divided being severally allotted to separate shells of ordinary size and sold as single oysters.

Mr. Saville-Kent congratulates New Zealand upon her abundant stores of oysters of various kinds. The days for the systematic artificial cultivation of the oyster in that colony have not yet arrived, and if she carefully husbands her natural resources they may, he thinks, be long delayed.

### THE TIBET EXPEDITION.

AT an extraordinary meeting of the Russian Geographical Society on October 14, General Pevtsoff made his report about the Tibet Expedition, of which he was the commander after the death of Przewalsky. Having crossed the main Tianshan ridge by the Bedel Pass, the Expedition went southwards, through an extremely narrow gorge of the Kara-teke ridge. In some places the gorge has only the width of 30 to 35 feet, while its walls are 700 feet high. The first Kashgarian village reached was Kalpyn, whence the travellers went to Yarkend. From Yarkend they moved on the great Khotan high-road into the northern spurs of the Kuen-lun. There they stayed for some forty days, at a height of 10,000 feet above the sea, at Tokhtahon, collecting many interesting plants and birds, while the geologist of the expedition, M. Bogdanovitch, made a long excursion into the region between the Yarkend-daria and the Tyznan Rivers. On September 13 they left the highlands, and after a three weeks' journey arrived at the Khotan oasis, the population of which (120,000) are skilful in the manufacture of carpets, felts, silks, and so on. From Khotan they went to Keria, and next to Niya, where they left their superfluous luggage, and whence they started to explore the Kuen-lun, in order to try to find a good pass to Tibet. The pass was found at the sources of the Tillan-hadj stream, not far from the Minjiilikhannu monastery. It proved to be quite available both for horses and camels. The winter was spent at Niya. On May 7, the work of exploration was resumed, and next week the Expedition reached the Kara-sai village. Followed by two men only, M. Roborovsky went up the Saryk-tuz Pass (discovered during the preceding autumn), and attained the sources of the Keriyadaria on the Tibet plateau. Its altitude proved to be there 16,500 feet, and its surface was an absolute desert. The want of food for the horses compelled M. Roborovsky soon to return to Kara-sai. He soon made a second attempt at further exploration, but, after having marched some 50 miles southwards on the plateau, he was again compelled to return. During the same time, M. Kozloff went across the border-ridge, following for some 100 miles the Bastan-tigrak River. He passed by Lake Dashi-kul and went up the river which flows into the lake from the east, through a wild desert, 14,000 feet above the sea. He also was soon compelled to return to Kara-sai. The next attempt was made by all three explorers together, accompanied by four Russians and a few natives. They went up the Aksu River, and soon were on a plateau, 15,000 feet high and almost quite devoid of vegetation. Terrible snow-storms were raging in the first days of July. The only mammals seen were two antelopes, and the only bird met with was a lark. Finding no food for the horses, the Expedition had nothing to do but to return to Kara-sai. Thence they started for Tcherchen, and at Atchan they were rejoined by M. Bogdanovitch, who had explored in the meantime the geological structure of the two passes of Saryk-tuz and Aksu. After a short stay at Mandalyk, where good grazing-grounds were found, and the horses recovered, the Expedition crossed again the Kuen-lun *via* the Muzluk Pass (15,500 feet high), and after having crossed it they divided into two parties, one of which, under M. Roborovsky, went south-east, and the other, under General Pevtsoff, moved southwards, up the little River Uluk-su, which is the source of the Tcherchen-daria. They soon came to an immense chalky mountain ridge, which rose to about 20,000 feet in the south, while a wide valley stretched south-westwards between that ridge and the Kuen-lun. The party stopped at the foot of this ridge, at a small lake, Yamil-kul. From some natives who were engaged in gold-mining in a gorge of the ridge, they learned that its name is Akkai-tai, and that its summits are covered with perpetual snow. The

party did not proceed further, and from Yamil-kul they returned to Mandalyk, and thence began their journey to Lob-nor, which journey took no less than one month. From Lob-nor the Expedition went up the Yarkend-daria, visiting on the way the great settlement of Kuria (4000 inhabitants), the fort of Karashar (10,800 inhabitants in the fort and the oasis), and the town Urunchi, situated at the foot of the Tianshan, and residence of the Governor-General of West China. On their way to the Russian frontier the travellers visited also the oasis of Sa-tan, peopled by Chinese, and crossed the Malas River as well as the desert Khatyn-ula. On January 15, 1891, they entered the Russian post of Zaisan.

### UNIVERSITY AND EDUCATIONAL INTELLIGENCE.

OXFORD.—The Rev. Andrew Clark, M.A., Fellow of Lincoln College, has been elected by Congregation a Curator of the Bodleian Library, in place of Prof. Max Müller, whose term of office had expired.

The Provost of Oriel College has been re-elected a Delegate of the University Museum.

Mr. F. Liddell, B.A. Christ Church, has been elected to a Fellowship at All Souls' College. Mr. Liddell, who is a son of the Dean of Christ Church, was placed in the first class by the examiners in the Final Classical Schools. Mr. A. H. Hardinge, M.A., formerly Fellow of All Souls' College, has been elected to a Fellowship under Statute 3, Clause 10, of the College Statutes.

There was no candidate for election to the Burdett-Coutts Scholarships. The scholarships are of the annual value of about £115, tenable for two years, for the promotion of the study of geology, and of natural science bearing on geology. This is the fifth occasion since the foundation of the scholarships that there has been either no candidate or no election.

In consequence of the requirements of the Civil Service Commissioners for the limited competition for assistantships in the Royal Observatory, Greenwich, the Savilian Professor of Astronomy has offered a short course of lectures on Newton's "Principia." The study of Newton has been practically abolished from the requirements of the Oxford Mathematical Schools for some time past.

A studentship, provided out of the funds of the Newton Testimonial Fund, having been offered to the University by the Managing Committee of the British School at Athens, the Craven Committee will proceed to make the appointment in the course of the present term. The studentship is of the value of £50, and is tenable for one year. The holder will be required to reside at Athens for not less than three months during the ensuing winter and spring. Candidates should apply to the Secretary of the Board of Faculties, Clarendon Buildings.

CAMBRIDGE.—The first award of the Isaac Newton Studentship in Astronomy and Physical Optics has been made to Ralph Allen Sampson, B.A., Fellow of St. John's College, Cambridge.

Prof. Thomson, F.R.S., has been elected Chairman of Examiners for Part II. of the Mathematical Tripos.

The vacancy of the office of Superintendent of the Museum of Zoology will take place on January 1, 1892. The stipend is £200. Applications are to be sent to Prof. Newton before November 19.

The State Medicine Syndicate report that this year there were 64 candidates for the Diploma in Public Health, of whom 45 were successful. They propose, on account of the large number of candidates, to hold a second examination in the first week of April 1892. The Syndicate have resolved to transfer to the University a sum of £150 from their accumulated funds.

### SCIENTIFIC SERIALS.

*American Journal of Mathematics*, vol. xiv. No. 1 (Baltimore, Johns Hopkins Press).—This number, which contains an excellent likeness and autograph of Prof. Klein, opens with articles by Goursat, "Sur un problème relatif à la déformation des surfaces," and by Appell, "Sur une expression nouvelle des fonctions elliptiques par le quotient de deux séries."—Major MacMahon, F.R.S., contributes a fourth memoir on a new

theory of symmetric functions. The author has extended the subject of these memoirs in a paper with the title "Memoir on symmetric functions of the roots of systems of equations" in the Philosophical Transactions, A. (1890).—The next paper, by C. P. Steinmetz, was read before the New York Mathematical Society, and is entitled "Multivalent and univalent involutory correspondences in a plane determined by a net of curves of  $n$ th order."—The following note, also read before the same Society, is on the algebraic proof of a certain series. It supplies a "temporary lack," which was regretted by the author, E. McClintock, in a memoir which will be found in vol. ii. p. 108. The same writer furnishes another addition to the memoir just referred to (vol. ii.), on independent definitions of the functions  $\log x$  and  $e^x$ .—H. B. Newton writes on a pair of curves of the fourth degree, and their application in the theory of quadrics; and H. P. Manning finishes this instalment with a note on linear transformation, which was suggested by a method employed by Prof. Cayley, F.R.S., in vol. v. of the *Amer. Journal*.

The articles in the numbers of the *Journal of Botany* for October and November are mostly of interest to specialists in local floras. Mr. A. Fryer describes and figures a new English *Potamogeton* (or, rather, hybrid). Mr. T. H. Buffham describes and figures the hitherto unknown plurilocular sporanges in two sea-weeds, *Asperococcus bullousus* and *Myriotrichia claviformis*. Mr. F. N. Williams contributes a synopsis of the primary characters in the species of *Rheum*.

The last number received of the *Botanical Magazine* published at Tokyo, Japan (for June), contains an interesting article, illustrated, on a new Japanese *Prasiola*, *P. japonica*, by Dr. R. Yatabe, which, the author states, is collected in large quantities in the districts where it grows, and is sold as an article of food under different names in different localities. It is eaten either slightly broiled or with vinegar, the mode of preparation being very similar to that of the ordinary purple and green lavers. Other articles in the same number are on the reproduction of *Laminaria japonica*; on a recent problem in vegetable physiology (apparently the greatly discussed question of the direct absorption of nitrogen from the air by plants); and on the colours and scents of flowers; but as all these are unfortunately in Japanese, they are inaccessible to the English reader.

The number of the *Nuovo Giornale Botanico Italiano* for October is chiefly occupied with the Proceedings of the Italian Botanical Society. The attention of Italian botanists is still directed to the interesting phenomena connected with the pollination of the Aroidæ: Signor Caleri has a paper on the flowering of *Arum Dioscoridis*, and Prof. Arcangeli one on the fertilizers of *Helicodictyon muscivorum*. He is unable to discover any evidence that the latter plant is really carnivorous.—Signor Martelli discusses a vine-disease which has lately appeared in the neighbourhood of Florence, and which he identifies with the "black rot" of the American grape, caused by a Pyrenomycetous fungus, *Phyalospora Bidwellii*.

## SOCIETIES AND ACADEMIES.

### LONDON.

Entomological Society, October 7.—Dr. D. Sharp, F.R.S., Vice-President, in the chair.—The Chairman referred to the death, on September 14 last, of Mr. E. W. Janson, who had been a member of the Society since 1843, and who had formerly filled the offices of secretary and librarian respectively.—The Rev. Dr. Walker exhibited a long series of several species of *Erebia*, and of *Argynnis pales*, which he had recently captured near Roldal, in Norway.—Mr. W. L. Distant exhibited specimens of *Danaus chrysipus*, with its two varietal forms, *alceippus*, Cram., and *dorippus*, Klug., all which he found together in the Pretoria district of the Transvaal. Mr. Jenner Weir and Colonel Swinhoe took part in the discussion which ensued as to these forms and their distribution.—The Rev. W. F. Johnson sent for exhibition specimens of *Velia curvans* from stagnant water near Armagh; also a specimen of *Nabis limbatas*, killed whilst holding on to its prey, a very hard species of Ichneumon. Mr. Saunders thought that, from the nature of the Ichneumon, the only chance the *Nabis* had of reaching its internal juices would be through the anal opening, as recorded by Mr. E. A. Butler in a similar case, in the *Entomologist's Monthly Magazine*, October 1891.—Mr. F. P. Pascoe exhibited two British

species of Diptera, unnamed. He said they had been submitted to Mr. R. H. Meade, but were unknown to him, and are probably new to the British list.—Mr. R. Adkin exhibited two specimens of a supposed new species of Tortrix (*Tortrix douglana*, Carpenter), bred from larvæ found on pine-trees at Taam. Mr. C. G. Barrett said he examined the specimens with great care, but he did not consider that they belonged to a new species. He was unable to distinguish them from *Tortrix viburnana*.—M. A. Wailly exhibited preserved larvæ, in various stages, of *Citheronia regalis*, which he had bred from ova received from Iowa, United States. He said that the natives called this larva the Hickory Horned Devil, and that the specimens exhibited were the first that had been bred in this country. M. Wailly further exhibited three female specimens of *Antheraea yama-mai* bred from cocoons received from Japan; also a nest of cocoons of *Bombyx radama*, received from the west coast of Madagascar. Prof. J. B. Smith, of the United States, and Colonel Swinhoe took part in a discussion on the habits of the larvæ of *Citheronia regalis*, and as to the period at which they dropped their spines prior to pupating.—Dr. Sharp exhibited several specimens of a weevil, *Ectopsis ferrugalis*, the ends of the elytra of which bore a close resemblance to the section of a twig cut with a sharp knife. He said he had received the specimens from Mr. G. V. Hudson, of Wellington, New Zealand, who stated that they were found resting in large numbers on dead trunks and branches of *Panax arborea* in the forests.—Mr. G. C. Champion stated that the species of *Forficulide*, captured by Mr. J. J. Walker, R.N., in Tasmania, and exhibited by himself at the meeting of the Society in April last, was, he believed, referable to *Anisobolis tasmanica*, Bormans, described in the *Comptes rendus* of the Ent. Soc. Belgique, 1880.—The Rev. A. E. Eaton made some remarks on the synonymy of the *Psychodide*, and stated that, since August 1890, he had identified all of the British species in Mr. Verrall's list, except *Sycorax silacea*.—Mr. Gervase F. Mathew, R.N., communicated a paper entitled "The Effect of Change of Climate upon the emergence of certain species of Lepidoptera." A discussion followed, in which Mr. Stainton, F.R.S., Mr. Barrett Dr. Sharp, F.R.S., and Mr. McLachlan, F.R.S., took part.

Royal Microscopical Society, October 21.—Dr. R. Braithwaite, President, in the chair.—The President said that the pleasure with which he met the Fellows after the vacation was very sadly marred by the death of one of their Secretaries, Mr. John Mayall, Jun. The loss they had sustained was one which the Society could hardly hope to replace, because perhaps there was no living person who knew more about the microscope and its applications than their deceased friend Mr. Mayall. The difficulty in which they were placed had, however, for the present been met by the kindness of Dr. Dallinger, who had undertaken to fill up the vacant place until the end of the current session.—Mr. A. D. Michael proposed, and Mr. T. H. Powell seconded, that a special vote of thanks be given to Dr. Dallinger for his kindness in accepting the office of Secretary. The vote of thanks was carried by acclamation.—Mr. F. Chapman read his paper on the Foraminifera of the Gault.—Sir Walter J. Selland exhibited and described a new apparatus which he had devised for making accurate measurements with the camera lucida, the inherent faults of which were explained by drawings on the blackboard. Mr. E. M. Nelson said there could be no doubt that camera lucida measurements when made in the ordinary way as described were grossly incorrect, and that the apparatus that had been devised was most ingenious and thoroughly scientific in principle. He thought, however, that there was a much simpler method of obtaining measurements by projecting the image for a distance of 5 feet; the curve would with so large a radius be practically reduced to a straight line. The camera lucida and neutral tint reflector were only rough-and-ready means, and useful only for ready reference; where correctness was of importance, the eye-piece micrometer would best meet the requirements; the ruling of eye-piece micrometers was now done so perfectly that it was possible to arrive at measurements even as small as 1/500,000 of an inch with far greater accuracy than could be attained with any machine. Dr. W. H. Dallinger thought there could be no doubt of the value of the apparatus within certain limits, but it would require great care for use with high powers, partly on account of its weight if made in brass, as the specimen before them; perhaps it might be made in aluminium or some other light material. The discussion was continued by Messrs. A. D. Michael, C. Beck, and Sir Walter J. Selland.—Mr. W. I.



Chadwick described the Leach lantern microscope as follows. The microscope can be applied to any oxy-hydrogen lantern. It is screwed on the front in place of the ordinary lantern objective, the size of flange required being  $2\frac{1}{2}$  inches; when the lantern objective flange is larger than this, an adaptor must be provided; and when the draw-tube of the lantern is "ricketty," a rigid lengthening tube may be adapted. The lantern condenser should be about 4 inches or  $4\frac{1}{2}$  inches in diameter, and of the triple form. The stage of the microscope is open at both sides, and at the top also, and serves for all classes of objects, whether ordinary microscopic slides or polariscope crystals, shown with either narrow angle rays or by the convergent system of lenses. The stage being so constructed, it is extremely accessible for the introduction of sub-condensers, with which the instrument is provided. The object-holder is quite a novel idea, the principal mechanism of it is placed under the stage (to be out of the way); two arms passing through slots in the bottom of the stage, actuated by a spring and manipulated by a milled head, serve to hold the objects flat against the inside surface of the front of the stage. The diaphragm, or compound wheel of diaphragms, is rotative on a pivot attached to the plate arm in such a manner that the whole may be raised out of the field altogether, and dropped into it again, in an instant; when the wheel is raised, a spring catch holds it in position. When in this position the whole field of the microscope can be utilized for showing objects up to  $1\frac{1}{2}$  inches in diameter. When, as in using polarized light, it is desired not to be incommoded with the diaphragms, the detachable plate carrying the compound wheel can be instantly removed from the stage, and when again required it can be as quickly restored. The arms of the object-holder projecting through the bottom of the stage have sufficient lateral movement to admit any zoophyte trough or wooden frame or combination of wooden frames up to 1 inch in thickness. Thus the advantages of this arrangement are clearly manifest. The two sub-condensers with which the instrument is provided are found to give satisfaction with all objectives of from  $2\frac{1}{2}$  to  $\frac{1}{2}$  inch focus. When the light has been properly concentrated, high powers can be used. It should also be observed that when high powers are used the front lens of the objective is open to the view of the manipulator, a great convenience when inserting the object, by enabling it to be immediately adjusted within the area of the lens. When polarized light is to be used, the polarizing prism must be pushed into the rotating tube of the instrument by removing the concave lens at the back, and after inserting the prism this concave lens may be replaced in an instant. The rotating tube is an advantage over fixed tubes, as the polarizing prism can by this arrangement be placed in any desired azimuth which best suits the object. The convergent system of lenses for use with polarized light in transmitting rays through biaxial crystals was worked out by Mr. Leach. It gives powerful illuminations, and includes an angle of  $170^\circ$ . The front focussing arrangement was introduced by Mr. Leach in 1883. Before that time several supplementary lenses had to be kept in readiness for use, as different classes of crystals were placed in the polariscope. Mr. Leach discovered how these supplementary lenses might be dispensed with, and fitted up his system accordingly; and now all makers of first-class polariscopes attach to their instruments this great improvement. The concave field lens, with which the instrument is provided, is absolutely necessary when the polarizing prism is in use. With all powers it enlarges the field, and equalizes the distribution of illumination. The three objective adaptors with which the instrument is provided admit of any microscope power with the standard screw; they are made to slide in the front tube of the microscope, which is provided with a rack and pinion, and also with a fine screw movement. Thus, by having the various powers already screwed into the adaptors, one may be changed for another almost instantaneously. And into the front or tube portion of these adaptors the tube of the amplifier is made to slide. The amplifier which is provided is a Barlow lens, and being achromatic, it enhances the applanatic qualities of the objective. It has been asserted "that high power cannot be used in the lantern microscope; that it is unable to exhibit fine detail upon the screen, and that no alum trough is required." No doubt this is all true so far as applied to inefficient instruments. But the Leach microscope does require an alum trough, because where great light is concentrated from the oxy-hydrogen luminant, great heat must, from the very nature of the means employed, be concentrated with it, and the alum trough is the only practical thing which can be used to absorb the heat rays.

The alum trough is of large size, and is used in the ordinary slide stage of the lantern. At the conclusion of the paper, Messrs. Chadwick and Leach gave a demonstration with common and polarized light.

## CAMBRIDGE.

**Philosophical Society, October 26.**—Prof. G. H. Darwin, President, in the chair.—The officers for the ensuing session were elected as follows:—President: Prof. G. H. Darwin. Vice-Presidents: Prof. Hughes, Prof. Thomson, Mr. J. W. Clark. Treasurer: Mr. R. T. Glazebrook. Secretaries: Mr. J. Larmor, Mr. S. F. Harner, Mr. E. W. Hobson. New Members of Council: Mr. H. F. Newall, Mr. C. T. Heycock, Mr. A. E. H. Love.—The following communications were made to the Society:—On the absorption of energy by the secondary of a transformer, by Prof. Thomson.—On an experiment of Sir Humphry Davy's, by Mr. G. F. C. Searle. Two copper wires are passed up through holes about 5 centimetres apart in the bottom of a flat trough, their ends being level with the surface of the trough. Mercury is then poured into the trough to a depth of about 4 millimetres. On sending a powerful current through the mercury by means of the two wires the mercury in the immediate neighbourhood of the electrodes was elevated into a small cone 2 or 3 millimetres in height.—Some notes on Clark's cells, by Mr. R. T. Glazebrook and Mr. S. Skinner. In addition to the causes of variation indicated by Lord Rayleigh, the authors find that the state of amalgamation of the zinc pole may cause a fall in force if the zinc does not show a bright surface. This is worked out by means of a testing cell into which the faulty zincs are transplanted. The result is confirmed by Swinburne's experiments on zinc rods in zinc sulphate solution. To correct this fault previous amalgamation in the presence of dilute sulphuric acid is recommended, or immersion of the zinc in the paste. Dr. Hopkinson's method of testing cells by tapping was shown.—Illustrations of a method of measuring ionic velocities, by Mr. W. C. D. Whetham.—On gold-tin alloys, by Mr. A. P. Laurie.

## PARIS.

**Academy of Sciences, November 2.**—M. Duchartre in the chair.—On aberration, by M. Mascart.—Note on Mont Blanc Observatory, by M. J. Janssen. This is a brief report of the attempt to reach the rock through the snow on the summit of Mont Blanc, in order to obtain a foundation for a proposed Observatory. In spite of circumstances which rendered the proposed building impossible, M. Janssen believed that an edifice of some kind resting on the snow would permit the necessary observations to be carried on, and had one constructed according to his ideas. No displacement of the erection occurred during the twenty days previous to M. Janssen's departure from the summit of the mountain. The construction of a similar but more important building is therefore contemplated for next year.—Note by M. Armand Gautier, accompanying the presentation of his work on "Biological Chemistry."—On the Arago Laboratory, by M. de Lacaze-Duthiers.—Contribution to the natural history of the truffles: parallelism between the Terfaz or Kama (*Terfezia, Tirmania*) of Africa and Asia and the truffles of Europe, by M. A. Chatin. In the comparison the points considered are geographical distribution, climate, soil, nutritious plants, periods of ripening, depth in soil, and numerous other characteristics.—An excursion in the Rocky Mountains, by M. Albert Gaudry. At the end of the recent Geological Congress at Washington a party was organized to visit the Rocky Mountains. An account is given of the objects of geological interest observed by the excursionists.—Note on the storm that visited Martinique on August 13, 1891 (an extract from the *American Journal of Meteorology*), by M. Faye.—Reserches on butylene monobromides, by M. E. Rebulon. There are three butylene monobromides known besides the isobutylene of Boulewer. The author describes the preparation and properties of one of these, to which he assigns the constitution  $\text{CH}_3\text{—CH}_2\text{—CBr—CH}_2$ . He proposes to term it ethyl-acetylene  $\alpha$ -hydrobromide.—Observations of two new asteroids discovered at Nice Observatory on September 24 and October 8, 1891, by M. Charlois. Observations of position are given.—On the dimensions and form of the section of a stream (*veine*) of gas under limited counter-pressure during a limited delivery, by M. Parenty.—On a model of a luminous fountain, by M. G. Trouvé.—On the direct combinations of metals with chlorine and bromine, by MM. Henri Gautier and Georges Charpy.

With the exception of aluminium, most of the metals are hardly attacked by dry chlorine and bromine at the ordinary temperature. Aluminium, however, is acted on very energetically by liquid chlorine and bromine, whilst magnesium particularly resists the action. The reactions are very slow when the dry halogens are used. When water is present the action becomes more rapid, hydrogen being generally liberated owing to its decomposition, but in some cases the water remains unaltered.—Contribution to the chemico-physical study of the function of the kidney, by M. C. Chabrier.—On the chronology of the eruptive rocks of Jersey, by M. A. de Lapparent.—New geological observations of the Island of Sardinia, by M. Charles de Stefani.—New considerations on the Vertebrate fauna of the Upper Miocene in the Isle of Samos, by M. Forsyth Major.—The gravels of Montfort, by M. Ed. Piette.

BERLIN.

Physiological Society, October 16.—Prof. du Bois-Reymond, President, in the chair.—Dr. Lüderitz gave an account of an investigation of the changes of blood-pressure in the left ventricle and right carotid which result from gradual compression of the aorta.—The President exhibited three very successful photographs of the posterior (retinal) surface of the eye.—Doctor Wertheim recorded the disappearance of the indirect image of an illuminated disk when the object itself, as seen directly, is suddenly darkened.—Dr. Lilienfeld gave an account of a chemical examination of blood-platelets, which showed that they consist of a compound of albumin and nuclei, whose behaviour speaks against their being preformed structures.

Physical Society, October 23.—Prof. du Bois-Reymond, President, in the chair.—The Society resolved to present to Prof. von Helmholtz, on November 2, in celebration of his seventieth birthday, an address prepared by Prof. von Bezold.—Messrs. Haensch described a modification which they had made in a spectrophotometer.—Dr. Rubens gave an account of a new method of determining dispersion and refraction in the ultra-violet rays, a method which, unlike that employed by Langley, yields more accurate results by very simple means. He has already made determinations with a series of glasses, with water and with carbon bisulphide. The curve of dispersion he finds to be, on the whole, the same as that obtained by Langley for rock-salt.—Prof. Preyer enunciated his hypothesis as to the genealogy of the chemical elements.

AMSTERDAM.

Royal Academy of Sciences, September 26.—Prof. van de Sande Bakhuysen in the chair.—Prof. Franchimont showed a little bottle filled with a new chemical compound, obtained and examined by Dr. C. A. Lobry de Bruyn. This hydroxylamine is a crystalline matter without colour and smell. It is prepared by the action of sodium-methylate on the methylalcoholic solution of the compound of hydroxylamine and HCl, and by distilling and fractionating the result *in vacuo*. The specimen is pure to 99.6 per cent; it melts at 31°·5, and distillates under a pressure of 35 mm. between 63°·5 and 65°·5.—Mr. Behrens spoke of the microscopic structure of hard steel. If high microscopic powers are used, the network in hardened steel may be made visible on polished slices without etching or annealing. The dark sinuous lines answering to the bright ones shown by Sorby and Wedding on etched slices, it is proved that hardened steel contains hard granules bound up in a matrix of soft iron. Some varieties of grey iron from small castings may be hardened like steel, most of the graphite disappearing. After annealing the hardened metal at a red heat, the slices were dotted with blackish dust, which formed circles round the globules of the crystallites and little heaps in the midst of them. It is to be presumed that graphite has reappeared in the course of the annealing. Full details will speedily be given in the *Recueil des travaux chimiques des Pays-Bas*.

## BOOKS, PAMPHLETS, and SERIALS RECEIVED.

Books.—Pflanzenleben, Zweiter Band; A. K. von Marilau (Leipzig, Bibliographisches Institut).—British Fungi: G. Masee (L. Reeve).—Studies in American History: M. S. Barnes and E. Barnes (Boston, Heath).—A Text-book of the Science of Brewing: E. R. Moritz and G. H. Morris (Spion).—The Universal Atlas, Part 5 (Cassel).—Geological and Natural History Survey of Canada, Annual Report, vol. iv., 1888-89 (Montreal, Foster, Brown).—Daily Weather Charts to illustrate the Tracks of Two Cyclones in the Arabian Sea (Eyre and Spottiswoode).—Meteorological Charts of the

portion of the Indian Ocean adjacent to Cape Guardafui and Ras Hafin (Eyre and Spottiswoode).—Arithmetical Physics: Part 2a, Magnetism and Electricity: 3rd edition; C. J. Woodward (Simpkin).—A Graduated Course of Natural Science, Part 2: B. Loewy (Macmillan).—Delagosa Bay, its Natives and Natural History: R. Monteiro (Philipp).—Observations made at the Hong Kong Observatory in the Year 1890: W. Doberck (Hong Kong).—Light, an Elementary Treatise: Sir H. J. Wood (Whittaker).—A First Book of Electricity and Magnetism: W. P. Maycock (Whittaker).—The Alkali-Maker's Hand-book; 2nd edition; G. Lunge and F. Hurter (Whittaker).—The Practical Telephone Hand-book: J. Poole (Whittaker).—The Plant-World: G. Masee (Whittaker).—T. Cooke and Sons' Catalogue of Astronomical and Scientific Instruments, 1891 (York).—A Text-book of Physiology, Part 4, 5th edition, revised: Prof. M. Foster (Macmillan).—Iconographia Florae Japonica, vol. i. Part 1: Dr. R. Yatabe (Tokyo, Maruya).—Catalogue of the Michigan Mining School, Houghton, Michigan, 1890-91 (Houghton).—Manual for the Physiological Laboratory, 4th edition: Drs. H. Harris and P. Waller (Baillière).—Die Entstehung der Landtiere, ein Biologischer Versuch: Dr. H. Simroth (Leipzig, Engelmann).—Revisio Generum Plantarum, Pars 1: Dr. O. Kuntz (Dulau).

PAMPHLETS.—Proposed Railway through Siberia: W. M. Cunningham (London).—Molecular Motion in the Radiometer, in Crookes' Tubes and in some other Phenomena: D. S. Troy (New York, Hodges).—Oysters and Oyster-Fisheries of Queensland (Brisbane).

SERIALS.—Quarterly Journal of the Geological Society, No. 188, vol. xviii., Part 4 (Longmans).—Morphologisches Jahrbuch, 17 Band, 4 Heft (Leipzig, Engelmann).—Quarterly Journal of Microscopical Science, No. 128 (Churchill).—Boletim da Comissao Geographica e Geologica do Estado de S. Paulo, Nos. 4-7 (S. Paulo).—Mittn. des Vereins für Erdkunde zu Halle a/S (Halle a/S).—Geological Magazine, November (K. Paul).—Jahrbuch der Meteorologischen Beobachtungen der Wetterwarte der Magdeburger Zeitung, Band ix. Jahrg. xx., 1890 (Magdeburg).—Records of the Australian Museum, vol. i. No. 5 (Sydney).—Journal of the Chemical Society, November (Gurney and Jackson).—Sitzungsberichte der k. Akademie der Wissenschaften Math. Naturw. Classe, xxix. Band, Abthg. 1, Heft 4-10; Abthg. 2a, Heft 4-10; Abthg. 2b, Heft 4-10; Abthg. 3, Heft 4-10 (Wien).

## CONTENTS.

	PAGE
The Hygiene of Water-Supply. By Prof. Percy F. Frankland, F.R.S. . . . .	25
Causation of Sleep . . . . .	26
Our Book Shelf:—	
Spencer: "Physiography—Elementary Stage" . . . . .	27
Lupton: "Mayhew's Illustrated Horse Doctor."—W. F. G. . . . .	27
Boerlage: "Handleiding tot de Kennis der Flora van Nederlandsch Indië."—W. B. H. . . . .	28
Step: "By Sea-shore, Wood, and Moorland" . . . . .	28
Letters to the Editor:—	
Note on the Chromosphere Spectrum.—Prof. C. A. Young . . . . .	28
Formation of a Temporary Cyst in the Fresh-water Annelid <i>Bolosoma</i> .—Frank E. Beddard . . . . .	28
Polytechnics and Recreation.—Miss Emma Cons "W = Mg."—Prof. Arthur G. Webster; A. G. G. . . . .	29
Alum Solution.—T. C. Porter . . . . .	29
The Salt Lake of Aalia Paakal.—A. B. Lyons . . . . .	29
<i>Meretrix</i> , Lamarck, versus <i>Cytherea</i> , Lamarck, 1806.—C. R. Osten Sacken . . . . .	30
A Plague of Frogs.—Lieutenant B. A. Muirhead, R. N. . . . .	30
Red Light after Sunset.—Dr. M. A. Veeder . . . . .	30
Topical Selection and Mimicry.—David Syme; Dr. Alfred R. Wallace . . . . .	30
Prof. Pictet's Laboratory at Berlin. By Prof. R. du Bois-Reymond . . . . .	31
Results of Experiments at Rothamsted on the Question of the Fixation of Free Nitrogen. By Dr. J. H. Gilbert, F.R.S. . . . .	32
Fossil Birds in the British Museum. ( <i>Illustrated</i> ). . . . .	33
Iron Carbonyl from Water Gas. By A. E. Tutton . . . . .	36
Cape Guardafui and the Neighbouring Sea . . . . .	36
Notes . . . . .	37
Our Astronomical Column:—	
Outburst of Dark Spots on Jupiter . . . . .	41
Wolf's Periodic Comet . . . . .	42
The Total Lunar Eclipse of November 15 . . . . .	42
The Elements of the Minor Planets . . . . .	42
Some Experiments made with the View of ascertaining the Rate of Propagation of Induced Magnetism in Iron. By Fred. T. Trouton . . . . .	42
Oysters at the Antipodes . . . . .	43
The Tibet Expedition . . . . .	45
University and Educational Intelligence . . . . .	45
Scientific Serials . . . . .	45
Societies and Academies . . . . .	46
Books, Pamphlets, and Serials Received . . . . .	48

THURSDAY, NOVEMBER 19, 1891.

## SCOTCH FISHERIES.

*The Ninth Annual Report of the Fishery Board for Scotland: being for the Year 1890.* (Edinburgh: Printed for Her Majesty's Stationery Office by Neil and Co., 1891.)

THIS, like the three preceding Reports, is published in three parts: I. General Report; II. Report on Salmon Fisheries; III. Scientific Investigations.

The first part deals with such matters as the statistics relating to fish landed and cured, Crown brands, number of boats and men fishing, an account of the services rendered by the various vessels employed in marine police and fishery superintendence; and generally, reports on all business matters connected with this section of the Board's work. The Shetland herring fishing seems to have been particularly successful, and to have attracted the usual number of English and Irish boats, but the reports as to the number of Scotch boats employed in this and long-line fishing tend to show that there is a gradual decrease; that the fishing does not now seem to hold out such attractions to the rising generation as it once did; that probably over-competition is telling upon this as well as other industries.

The chief article in the second part is the annual report of Mr. Archibald Young, Inspector of Salmon Fisheries for Scotland. It contains an account of the fishings in the various rivers and lochs, with answers to queries from district boards and local fishing authorities. The question of the advisability of having a close-time for trout is only casually mentioned; and we cannot but think that the Board would do well if, with all the facilities at its command, it paid more careful attention to such matters as the life-history and habits of the salmon. Many points of great interest and usefulness have still to be settled: for instance, we see no attempt to distinguish between the different "runs" of fish in the various rivers, their spawning periods, and subsequent movements. We are not told whether, in the case of the salmon hatcheries, any attention has been paid to the spawning of spring run fish—probably a point of great importance in early rivers. Might the Board not collect and publish much valuable information as to the best means of keeping up a steady supply of Salmonidæ, by looking at the question a little more with the interest of the naturalist and sportsman? A great deal of information is yet required as to late and early spawning, migratory movements of the young, rate of growth in the sea, food, &c. To carry out some of these inquiries might possibly require more legal power than the Board possesses, but that the Fishery Board is in a more favourable position than other fishery authorities will be generally admitted. These excellent reports as to the state of the salmon fishings should be used more as a means for improving that state than as the finished results of a year's inspection.

The third or scientific section of the Report is a volume of nearly 430 pages. The word *scientific* has, with the Fishery Board, a significance of its own: it

covers a multitude of subjects, but is on the whole a convenient title. Part III. is subdivided into four sections. In the first (A.), after detailed tabulated results of the work done by means of the cruiser *Garland*, &c., there are one or two papers deserving of special mention.

A paper by Dr. Fullarton, "On the Suitability of Scottish Waters for Oyster Culture," is an exhaustive account of an expedition made by him to a great number of lochs on the west coast, and shows clearly that some of these lochs formerly produced an abundance of oysters, and have had, within recent years, an abundant fall of spat on their spawning beds. A table of temperatures and densities is also given, which is valuable, but would certainly have been much more so if the temperature readings had been given in the common Fahrenheit instead of the Centigrade scale. The next paper is by the Secretary for Scientific Investigations, Dr. T. Wemyss Fulton, on "The Capture and Destruction of Immature Sea Fish." The two most important parts of this paper deal with the vitality of trawled fish, and the numbers of immature fish taken by shrimpers. It is the first attempt ever made to collect accurate data as to the proportion of living and dead fish brought up in a trawl net worked upon a certain kind of bottom for a certain length of time. The information regarding the number of immature fish taken by shrimpers has been collected in the Solway Firth and on the Lancashire coast. The results cannot but be surprising to very many. Taking the Solway alone, Dr. Fulton's totals show that, in one year, a single boat captures over 110,000 immature plaice. It is gratifying to learn that in this district the fishermen are, for once, provident, and return to the sea all these little fishes, for the sum-total of all immature fish landed in the year, comes to about 3,653,000. Dr. Fulton finds that, owing to the short time the shrimp trawl remains at the bottom—a sandy bottom—none of the young fish die. This contradicts a statement very generally made by those who denounce the system of fishing with beam trawl, and also is exactly the reverse of the finding of M.M. Giard and Roussin in their report on this subject to the French Minister of Marine—a report founded, however, not on experimental observation, as Dr. Fulton does not fail to point out. These observations further seem to show that very young fish caught in a shrimp trawl are much more tenacious of life than older fish taken in a large net of similar construction, and under similar conditions. This point, we think, is of some importance, and has not been sufficiently taken notice of. It bears on the question of size of mesh and destruction of small fish taken.

The biological section opens with a long paper, "On the Food of Fishes," by W. Ramsay Smith, B.Sc., and, following this, another paper by Dr. Wemyss Fulton, on "The Comparative Fecundity of Sea Fishes." In this paper the author first deals with the proportional weight of the ova compared to the rest of the body. This naturally leads him into the somewhat complicated subject of the proportion of eggs ripe at the spawning-time of certain fishes which do not shed their spawn *en masse*. He finds that in such cases it would often be an impossibility for the body of the fish to contain all the eggs it naturally produces in an enlarged and ripe condition. Taking

the instance of a plaice, it is shown that, if all its ova were ripe at once, the mass of eggs would themselves weigh a pound and a half heavier than the body of the fish without the ovaries.

Fish with demersal ova are distinguished from fish with pelagic ova, and tables are constructed which show the ratio of the weight of the ova present at one time, to the weight of the rest of the fish taken at 1000. The final results are given in the form of mean ratios. Dr. Fulton then goes on to draw three conclusions from his data. First, he says, it appears "to explain the majority of cases in which the females of a species are in excess of the males." What precisely explains this we are quite at a loss to see, and we cannot imagine an explanation which has not in it either a statement regarding the preponderance of the female element in the early nuclear plasma of the eggs, or an account of a wholesale destruction of males. The second point is the generally greater size of the female, and the third, "not merely the gradual growth of ova to replace mature ova shed during a prolonged spawning period, but the more or less sudden increase of bulk, which occurs in the ovum shortly prior to its extrusion." The second point seems to us to be like the first in requiring a more complete explanation; the third to be the clearest point advanced. The remainder of the paper is taken up with detailed statements, treating the fish according to their classification.

Among the papers following we have examples of Mr. Scott's conscientious systematic work in his second paper on "The Invertebrate Fauna of the Inland Waters of Scotland," and "Additions to the Fauna of the Firth of Forth."

Dr. Fullerton contributes a paper on "The Development of the Plaice—Preliminary Report." There are a number of excellent figures, but as there seems to be little that is new in the text, we do not give it further mention.

Prof. McIntosh adds to his already long list of observations "On the Life-Histories and Development of the Food and other Fishes." Interesting forms, such as a hybrid brill, lesser weaver, and sand-eel, are dealt with, as well as several unknown eggs and a curious unknown post-larval form.

Prof. Prince, so often associated with Prof. McIntosh, follows with "Notes on the Development of the Angler Fish (*Lophius*)."

In his statement that "hitherto no British observer has secured the ova," he has overlooked the fact that, in some previous notes by one of the naturalists to the Fishery Board, the procuring of a mass of ova was recorded. This, of course, in no way detracts from the interest of Prof. Prince's valuable paper.

The biological section closes with a note on "A Case of Hermaphroditism in a Haddock," by W. Ramsay Smith. Both ovary and testis appeared perfectly normal, and were removed from a fish 18 inches long, and 3 pounds in weight.

The physical investigations of the Board are dealt with by Dr. Mill in Section C.; and a review of the contemporary scientific fishery investigations, by Dr. Wemyss Fulton, forming a fourth section, brings the Report to a close.

### THE MAMMALS OF INDIA.

*Catalogue of Mammalia in the Indian Museum, Calcutta.*  
By W. L. Sclater, M.A., F.Z.S., Deputy Superintendent of the Indian Museum. Part II. (Calcutta: Printed by order of the Trustees of the Indian Museum, 1891.)

THE Indian Museum at Calcutta is rich in Mammals. Not only are those of our Eastern possessions well illustrated, but it possesses also a good general series from other parts of the world. The collection has, moreover, the advantage of being well catalogued. In 1863, the late very zealous and acute zoologist, Edward Blyth, published a catalogue of the specimens contained in the Museum of the Asiatic Society of Bengal. This Museum, when transferred to the Government of India, formed the nucleus of the present Indian Museum. The 1330 specimens mentioned in that catalogue have now increased to 4872, representing 590 species, of which 276 are found within our Indian Empire, and 314 are exotic.

Of this greatly augmented collection Dr. John Anderson commenced a catalogue, and the first part, containing the orders Primates, Prosimiæ, Chiroptera, and Insectivora, was published in 1881. In consequence of Dr. Anderson's relinquishing his appointment as Superintendent of the Museum, the work has remained in abeyance for some years; but it has now been taken up and completed by Mr. W. L. Sclater, the present Deputy Superintendent, and eldest son of the distinguished Secretary of the Zoological Society of London. This volume contains the orders Rodentia, Ungulata, Proboscidea, Hyracoidea, Carnivora, Cetacea, Sirenia, Marsupialia, and Monotremata.

The Mammals of our Indian Empire have attracted the attention of many well-qualified zoologists. Hodgson, Blyth, Jerdon, Tickell, Horsfall, Elliot, Dobson, Anderson, and others, have contributed much to elucidate their history, habits, and distribution. The work now being published under the auspices of the Indian Government by Mr. W. T. Blanford, the first part of which appeared in 1888 (see NATURE, vol. xxxviii. p. 513), contains a valuable summary of all that is known upon the subject up to the present time. Mr. Sclater's work is of a less ambitious kind, professing to be only a catalogue of the Mammalia contained in the Museum, not mentioning any other species. Such catalogues are not only invaluable for working purposes in the institution itself, but they have also a more extended area of usefulness, being often works of reference which no zoologist investigating the group they treat of can dispense with. In the present case there will be found under the heading of every species much information as to its literature, synonymy, and geographical distribution. As catalogues naturally deal largely with names, the selection of those which accord best with a common-sense interpretation of the rules of zoological nomenclature is a matter of primary importance, and in this respect Mr. Sclater appears to have shown upon the whole great judgment, having been careful to avoid unnecessary alterations in generally accepted names, either such as are caused by splitting genera, or by reviving obsolete, long-forgotten, or never received specific appellations. Although no de-

tailed specific descriptions are attempted, the work is rendered more useful than a mere list would be, by the introduction of keys, by means of which all the Indian species can be discriminated. There are also some critical remarks upon disputed questions of specific distinction, which the large series of specimens at the author's disposal has enabled him to throw light upon, such as the identity of *Ovis poli* of the Pamir and the so-called *Ovis karelini* of the Thian Shan. Under the heading *Elephas indicus*, we note that Mr. Sclater refers to Schlegel's having pointed out in a well-known memoir (of which a translation appeared in the *Natural History Review*, vol. ii., 1862) certain distinctions between the true Indian elephant and that inhabiting the islands of Ceylon and Sumatra (*Elephas sumatranus*, Schlegel), and he repeats the characters assigned to the two supposed species or varieties. Although no fresh evidence is brought forward in favour of Schlegel's views, it is not likely that Mr. Sclater would, without good reasons, reject Dr. Falconer's elaborate refutation of them, published in the succeeding volume of the same Review. Dr. Falconer was such a great authority on elephants, and his arguments for the specific unity of the Asiatic forms have been so generally held to be sound, that Schlegel's two species can only be rehabilitated by a careful comparison of a considerable series of specimens undoubtedly natives of both localities. Perhaps Mr. Sclater may have an opportunity of doing this while in the East, and thus definitely settle a question of considerable zoological interest.

W. H. F.

#### A TEXT-BOOK OF CHEMICAL PHYSIOLOGY AND PATHOLOGY.

*A Text-book of Chemical Physiology and Pathology.* By W. D. Halliburton, M.D., B.Sc., M.R.C.P. (London: Longmans, Green, and Co., 1891.)

IN spite of the fact that several standard works on the subject of physiological chemistry exist, both in German and English, the need has nevertheless been universally felt of one that should at the same time present a review of the present condition of the subject from an impartial standpoint, and give some account of the methods of research employed.

Hoppe Seyle's works have been of immense service, but suffer from being onesided, and representing only the views and methods of the Strassburg school. The only work in English which promised to be universal in its scope—namely, that by Gamgee—is unfortunately still unfinished.

Prof. Halliburton, who is justly celebrated for his work in all departments of physiological chemistry, has attempted to fill this gap in our literature, and with a large measure of success.

The first fifty pages of the book are taken up with an account of the apparatus and analytical methods chiefly employed in physiological chemical research. The only fault we have to find with this part of the book is that there is not enough of it. In a book intended as a guide to those who would work practically at the subject one hundred and fifty pages might well be devoted to these subjects, seeing that so many workers devotedly attack the chemical

problems of physiology with scarcely any practical knowledge of chemical analytical methods.

The second part treats of the chemical constituents of the organism, concluding with two chapters on fermentation and ptomaines, the chapters on the latter and on proteids being especially good, and presenting an excellent *résumé* of our present knowledge of these subjects.

The next section is taken up with an account of the tissues and organs of the body. Here the author is thoroughly at home, and can speak with the authority of many years' practical work at the subject. It is rather difficult, however, to see on what principle he includes respiration in this part, especially as the subjects of alimentation, excretion, and general metabolism have each a part to themselves; unless it be, that it is so intimately connected with the physiology of the blood. In this chapter a student might be led astray by seeing the table of relations between the tension of the gases in venous blood and of those in the alveolar air. The important thing to know is the tension of gases in arterial blood; and by giving those in venous blood in juxtaposition to those in the alveolar air, the author glosses over the difficulties presented by the question of gas interchange in the lungs. In this connection, too, he does not notice Bohr's important work on the subject (interchange of gases in the lungs), although he gives a full account of the Danish physiologist's researches on the combination of hæmoglobin with  $CO_2$ .

In the latter part of the book no reference is made to Altman's views on fat absorption, or to Ehrlich's suggestive work on the oxidative processes taking place in living tissues.

But a few errors of omission are inevitable in a work of this size and scope, and Dr. Halliburton wins our admiration for the completeness and correctness of his book, which everywhere shows signs of the care with which the proof-sheets have been revised and brought up to date. The accounts of recent analytical methods and work render it invaluable in a physiological laboratory, and it will be repeatedly referred to by students who desire more than a superficial knowledge of the subject. In Germany it has already found favour with physiologists, and is considered the best work on the subject. The fact that it is being translated into German, under the auspices of Prof. Kühne, is of itself sufficient recommendation for any work; and there is no doubt that in its new dress it will command as much success in Germany as it has already commanded in England.

E. H. STARLING.

#### OUR BOOK SHELF.

*Praktisches Taschenbuch der Photographie.* By Dr. E. Vogel, Assistant in the Photochemical Laboratory of the Technical High School of Berlin. (Berlin: Robert Oppenheim, 1891.)

THIS is a small volume, of some 200 pages, but it is full of useful information for working photographers, whether amateurs or professionals. Under nine sections the author treats of all the subjects likely to be required by the manipulator of the camera, from the purchase of his apparatus onward through every detail essential for successful work. The value of the book is greatly enhanced by numerous illustrations, which are

executed with that clearness and finish for which so many Continental scientific works are justly to be commended. To give an idea of its contents it will be sufficient to mention the headings of the sections, viz. apparatus for the negative process, photographic objectives, instantaneous shutters, portable cameras, equipment of the dark room, general remarks on exposure, negative processes, positive processes, cyanotype and similar processes. The work, as its title implies, is purely technical, and, as such, does not call for lengthened notice in these columns, but for the particular object with which it has been written it is admirably adapted, and should find many readers in this country. We have nothing which can be compared with it for conciseness and completeness.

*An Introduction to the Differential and Integral Calculus.* By T. Hugh Miller. (London: Percival and Co., 1891.)

THIS small book contains a fair amount of the calculus put together in a clear and readable form. It merely touches the subject, but appears to contain enough to meet the wants of a South Kensington examinee. "It assumes a knowledge of elementary algebra and trigonometry as far as the properties of plane triangles." The student is supposed to be unacquainted with analytical geometry, but as he is credited with a knowledge of the exponential and binomial theorems, with "indeterminate coefficients" and a few other matters, it will be seen that *elementary* includes a fair grasp of the two subjects named. Six chapters are devoted to the elements, successive differentiation, the theorems of Leibnitz, Taylor, and Maclaurin, maxima and minima values of a function of one variable, and the evaluation of indeterminate expressions; the remaining four chapters are devoted to elementary integration, formulæ of reduction, rational fractions, and a few applications of the integral calculus. We presume that the miscellaneous examples are taken from South Kensington papers; those in the text are old friends which figure in Todhunter's works. In the text, the following slips occur: p. 4, l. 15, for  $f(x)$  read  $f'(x)$ ; p. 18 (6), read  $e^x$ ; p. 37 (3), for  $\frac{x^0}{720}$  we get  $\frac{x^6}{5}$ ; p. 40 (3), ?  $(a-b)^2/a$  for the maximum; p. 41, l. 4 up, for  $2a+3b$ , read  $3a+2b$ ; p. 42 (1), read  $\cos^3 \theta$  and  $3\sqrt{3d^2/16}$ ; p. 62 (4), ? last connecting sign (read -); p. 71 (4), for  $\pi$  read  $\pi^2$ ; p. 80 (24), in first place read  $(1+x^2)^2$ . In the answers, we differ from the author in (1), (20), (74), and (88). We prefer to work (84) from  $\int (1+t^2)^{3/2} dt$ , where  $t$  stands for  $\tan x$ .

*Star Groups.* By J. Ellard Gore. (London: Crosby Lockwood and Son, 1891.)

A KNOWLEDGE of the principal constellations visible in our latitudes may be easily acquired from the thirty maps and accompanying text contained in this work. All stars down to the sixth magnitude are shown, and brief descriptions given of the objects of interest in each constellation. The maps are intended to be useful as an introduction to larger atlases, and will doubtless serve this purpose well; but a beginner unacquainted with the motions of the heavenly bodies will hardly find in them what he requires. G.

*The Universal Atlas.* (London: Cassell and Company, 1891.)

THIS atlas is being issued in twenty-eight parts, including the index, eight of which have already appeared. It contains fifty-eight single page maps and thirty-two double page, several illustrating physical geography. The maps are well drawn and reproduced, and full of detail, whilst

their large scale has enabled the names of all places of any importance to be printed with perfect legibility. In fact, all who require a good atlas, for reference or otherwise, would do well to obtain this one. G.

*La Transcaucasie et la Péninsule d'Apchéron.* Calouste S. Gulbenkian. (Paris: Hachette et Cie., 1891.)

THIS is a very pleasant book of travels, well worthy of the attention of all who for any reason take interest in the Caucasus. The author has no very stirring adventures to tell us of, but he presents lucid and attractive descriptions of the towns and districts through which he passed, and of the manners and customs of the inhabitants. Especially good are the chapters he has devoted to the petroleum industry—chapters which have already appeared in the *Revue des Deux Mondes*. He gives also a very interesting account of Oriental carpets, the manufacture of which plays so great a part in the Caucasus.

*How to Organize a Cruise on the Broads.* By E. R. Suffing. (London: Jarrold and Sons, 1891.)

IN preparing this little book, the author did not attempt to provide a guide to the Broads. He intended the volume to serve merely as a supplement or appendix to the various guides already accessible. A cruise on the Broads is heartily enjoyed by everyone who tries it under tolerably favourable conditions, and certainly not least by students of natural history. Anyone who may think of making the experiment will find in Mr. Suffing's pages all the information that is really necessary for the formation of suitable plans. In one chapter he presents a brief and interesting diary of what may be looked for at the Broads during the various months of the year.

#### LETTERS TO THE EDITOR.

[The Editor does not hold himself responsible for opinions expressed by his correspondents. Neither can he undertake to return, or to correspond with the writers of, rejected manuscripts intended for this or any other part of NATURE. No notice is taken of anonymous communications.]

#### A Difficulty in Weismannism.

I HAD intended to accept Prof. Hartog's challenge, and say a few words on this subject at an earlier date, but absence from home and many engagements have interfered until now.

In some respects it would have been more convenient to defer such a discussion until Weismann's last essay, "Amphimixis," has become more widely known, or even until the appearance of his complete and detailed work, which is expected some time next year. Prof. Weismann tells me that the points raised by Prof. Hartog are considered in this treatise, and, such being the case, he is unwilling to tax his already over-strained eyesight with any earlier reply.

As the question has been raised, I will briefly speak of the manner in which I have tried to see my way through such difficulties. I do not, however, wish to involve anyone else in the responsibility for the attempt, which is no doubt crude and insufficiently thought out.

Accepting Prof. Hartog's five theses as fair statements, I have always proceeded to make his hypothesis B, and in this I believe I am following Prof. Weismann. Hypothesis A had never occurred to me, and I agree with Prof. Hartog in considering it as valueless. But I believe a way through the difficulties raised against hypothesis B may be found in the assumption of a relationship between the Ahenplasmas in the germ-cell. Such a relationship is perhaps hinted at by Prof. Hartog in Thesis III., where he speaks of these units as lying "associated together," and in this respect the metaphor of two packs of cards in Thesis IV. is, I believe, inadequate. I have always been accustomed to regard the relationship between the ancestral units, the "pattern" or figure which they form, as an essential part of the process. I have regarded the units as the necessary material, like the pigments in a colour-box, while their arrange-

ment would correspond to a finished picture. With such a conception I should prefer in Thesis IV, the metaphor of a kaleidoscope. The pattern at any one point will determine the pattern that succeeds, although, with an infinite number of pieces, the latter must always be different. But though differing, the successive patterns will resemble each other far more closely than those which are separated by wide intervals. Similarly, I do not think it is inconceivable that the arrangement of the ancestral units may have a determining effect on the arrangements which will succeed, in spite of the loss and restoration of half the units in each generation. Such a conception has the further advantage that it renders intelligible the action of external conditions on the germ-cells, either directly or through the medium of the body-cells. The ancestral units may be excessively stable, but the arrangements may be modified by a shock, just as the pattern in a kaleidoscope may be changed by a blow instead of the "normal" process of rotation (corresponding, of course, to the loss and restoration of half the units).

Oxford, November 16. EDWARD B. POULTON.

#### Town Fogs and their Effects.

THE influence of fogs on health, referred to in the very interesting paper by Dr. Russell (NATURE, November 5, p. 10), seems to call for further investigation. On the face of it, and judging by the composition of fogs, the discomfort they bring, their hurtfulness to plants, &c., fogs must surely damage health. And the injurious effect, I would point out, might not be at once apparent in the death-rate. What, on the other hand, is the precise nature of the beneficial effect of fogs (for such there seems to be)? If they plague mankind, they probably also plague those enemies of mankind, the minute organisms on which disease depends. And if so, we might even suppose some lives to be saved when fog comes on. It would be interesting to hear from hospitals for special diseases, how the patients are affected by fog. I understand that people suffering from asthma often rather enjoy a fog, or the sulphureous atmosphere of the Underground Railway. Has this ever been explained?

M.

#### The Eclipse of the Moon.

I VENTURE to send some notes upon last night's eclipse of the moon, taken by me here up to 11.35 p.m., when the sky became rather suddenly and entirely overcast.

The first indication of the penumbra of the earth's shadow was distinctly visible upon the north-east limb of the moon a little before 10.25; and at 10.35 (time given by the almanac) her north-east limb was well in shadow, and hidden by a remarkably dense or black shadow. At this time the sky here was quite clear, and promised to keep so for some time. At 10.45 the shaded part of the moon was so dark as to be invisible upon the sky even through glasses. At 10.50 a very beautifully coloured prismatic "cock's eye" formed in the sky exactly opposite the shaded limb, taking a fan-like shape radiating from that side of the moon; the prismatic colours being repeated twice, as in a double quadrant of a rainbow; while the sky round the bright part of the moon was clear and uncoloured. At 10.55 a thin white cloud, with ring of prismatic colours, formed round the moon; the earth's shadow still remaining very dark, with well-defined edge, and little or no penumbra beyond it. At 11.5 the thin cloud entirely cleared, the shadow still very dark, the upper and lower edges of the moon's limb just visible as threads of light upon the sky; and at 11.10 a very slight warmish tint appeared about the north-east part of shadow. At 11.15 the sky very clear and dark about the moon, stars before invisible coming out brightly. The earth's shadow was now well advanced over the moon, strongly defined, and as dark as the sky beyond it. At 11.22 light thin clouds again gathered round the moon, a narrow crescent of her only remaining. At 11.25 the moon became wholly hidden by a dense cloud. At about 11.35 I caught a momentary glimpse of the moon through the cloud, a very small part of her south-west limb just showing. At 11.40 sky entirely overcast; a faint aurora or red colour spreading upward, apparently below this cloud or mist, from the north.

I have only to add that the darkness and absence of colour of the shaded part of the moon was even more marked in this eclipse—so long as I was able to observe it—than in that of October 4, 1884, which was then set down to an abnormal

NO. 1151, VOL. 45]

density of the earth's atmosphere, and was supposed to have some connection with the strange sunsets and other phenomena of that period. I was not altogether unprepared for the same general character in last night's eclipse, as, so far as my own observations go, I am led by them to believe that the conditions then present in our atmosphere are still with us.

Southampton, November 16.

ROBERT C. LESLIE.

#### Comparative Palatability.

THE following observations were made during the last week of September and first of October:—

Two tadpoles of the small newt were taken by a "silver-fish." Three others, placed next day in the globe containing this fish and two goldfish, were not swallowed, though attempted from time to time. A brandling (*Alloleobophora fatida*) was once taken by the same silver-fish; but refused the next day and afterwards.

A large frog (♀) ate brandlings readily. Two slugs were taken by frogs. Tadpoles of the small newt were disregarded.

A very interesting experiment was made with a brimstone butterfly (*Rhodocera rhamni* ♂). It was offered to a frog which had just taken a *V. urticae*. Though fairly seized several times, the brimstone was always rejected. After one rejection, a second *V. urticae* was swallowed; after another, a *Spilosoma* larva. The butterfly was then given to a spider, which attacked it, but left it unbound. A *V. urticae* placed in the web was at once seized, partially wound, and sucked. Then the spider returned to the brimstone; but immediately left it again for the *Vanessa*, which was thoroughly wound, sucked, and moved higher up into the web. At dusk, the brimstone had been very imperfectly fastened. Next morning, however, it had been taken up by the spider.

That a frog is not much hurt by the nippers of *Ocyrops* is shown by the following experiment. A specimen which had been taken from the side seized the frog's tongue, was rejected after a few minutes, and removed by the forceps. The frog immediately after took a large earthworm.

Small frogs are exceedingly bold and voracious; often attacking prey which is as large as themselves, and which they could not possibly swallow. House- and harvest-spiders, hairy and smooth larvæ (among them those of *Spilosoma* sp. and *Manestra persicariae*), ladybirds, earthworms, brandlings, and silver-Y moths, were all swallowed somehow; while large "devil's coach-horses" were invariably attacked. Tadpoles of the small newt were disregarded.

E. B. TITCHENER.

Inselstrasse 13, Leipzig.

#### The Inheritance of Acquired Characters.

WILL you allow me to call the attention of your readers to a sentence in Mr. Hemsley's review of Schimper's and Karsten's works on the mangrove vegetation? "Mangroves grown in soil free, or practically free, from chloride of sodium, develop foliage of less substance, furnished with a larger number of stomata." If this means, as I understand it, that the change takes place immediately with the change in the conditions of growth, it would be very interesting to have further details; as the fact would furnish a very strong argument that the peculiarities in the mangrove vegetation are the result of the inheritance of acquired characters.

ALFRED W. BENNETT.

St. Thomas's Hospital, November 7.

#### "The Darwinian Society."

IN your issue of November 5 (p. 19) information is given that a local Society is about to be inaugurated in Edinburgh, under the title "The Darwinian Society."

As the Society is apparently to be merely for the encouragement of the study of natural science in the University of Edinburgh, the name is surely too pretentious to be suitable; and it is one that might well, I think, be kept in reserve for bestowal in later years upon a chartered Society of similar magnitude and as far-reaching extent as that founded in honour of Linnæus. It is therefore to be hoped that a more applicable name than the one proposed may be found for the new Edinburgh University Society.

WILLIAM WHITE.

Sheffield, November 10.

SOME NOTES ON THE FRANKFORT INTERNATIONAL ELECTRICAL EXHIBITION.

V.

The Evolution of the Multiphase Alternate Current Motor.

THE two-phase alternate current motor described in Part IV. has the disadvantage that, not merely does the magnetic field rotate, but it also varies in strength: this causes the driving force to fluctuate, and diminishes the power that the motor would otherwise give out. That there is this variation in strength of the magnetic field

all the four coils will always help one another to magnetize the iron ring, hence the magnetizing force at any moment will be approximately proportional to the number of convolutions in one of the coils multiplied by the arithmetical sum of the ordinates of all the four coils I, II, I<sub>2</sub>, and II<sub>2</sub>, that is, multiplied by twice the ordinate of the upper or summation curve.

If the maximum ordinate of either of the curves I or I<sub>2</sub> be called H, the ordinate of the upper or summation curve is equal to H when the time is *a, c, or e*, corresponding with the illustrations marked *a, c, and e* in Fig. 12; whereas the ordinate of this summation curve is  $\frac{2}{\sqrt{2}} H$ , or 1.414H, when the time is *b, d, or f*, corresponding with the illustrations marked *b, d, and f* in Fig. 12.

Hence, if K be the number of convolutions in one of the coils, the sum of the products of the current into the number of convolutions, or the number of ampere-turns, as it is called, will vary between two values proportional to HK and 1.414 HK—that is, will vary by 41.4 per cent. The variation in the magnetism produced by such a change in the number of ampere-turns will be less than 41.4 per cent., and much less if the magnetic induction be considerable; still, the fluctuation in the strength of the rotating field may be greater than is desirable.

If in place of the two pairs of coils (Fig. 12) there be three, I, I<sub>2</sub>, II, II<sub>2</sub>, III, III<sub>2</sub>, as in Fig. 18, and if the alternating currents passing through these three circuits be of the same maximum altitude and periodic time, but differ by 60° in phase, the variation in the number of ampere-turns will be much less than if only two alternating currents be employed. For on examining the sum of the ordinates of the three continuous curves, I, II, III (Fig. 19), which are the curves of three such currents, we see that the sum, or the ordinate or the top curve, varies between  $2H \sin 60^\circ$ , when the time equals *t*, and  $H + 2H \sin 30^\circ$ , when the time equals *t*. Hence this sum varies between  $\sqrt{3}H$  and 2H, corresponding with a change of only 14 per cent. in the magnetizing force, and with less than 14 per cent. in the magnetism produced.

Such a system, however, would require six wires, whereas the same reduced maximum variation of the number of ampere-turns can be practically attained by employing only three wires conveying three alternate

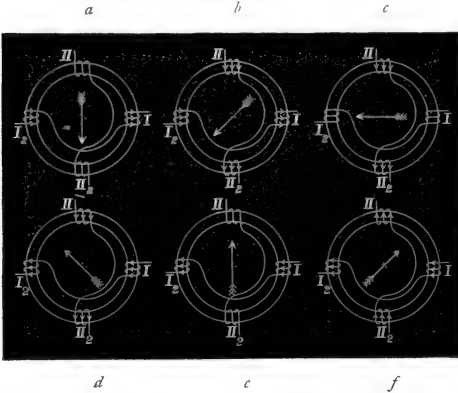

FIG. 12 (repeated).—Rotating magnetic field produced by two alternating currents, differing by 90° in phase.

may be seen from Fig. 17, where the continuous curves I and II show at any moment the strengths of the currents in the coils I and II, Fig. 12 (repeated for reference from the last article); while the dotted curves I<sub>2</sub>, II<sub>2</sub>, in Fig. 17, give the values at any moment of the currents in the coils I<sub>2</sub>, II<sub>2</sub>, in Fig. 12. For example, when the time equals *a* (Fig. 17), the currents flowing in

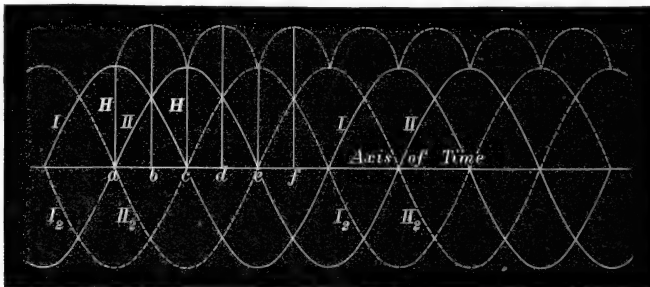

FIG. 17.—Two harmonic alternating currents of the same period and maximum amplitude, but differing by 90° in phase.

the coils I and II have respectively their maximum value and nought; whereas when the time equals *b*, the currents flowing in each of these coils is the same, being equal to  $2 \times \sin 45^\circ$  into the maximum value.

Now if each of the four coils occupies only a small portion of the ring, as shown in Fig. 12, the currents in

currents differing by 120° in phase, and by joining up the motor as shown in Fig. 20.

That it is possible to use only three wires, so that either wire always acts as the return wire for the currents in the other two, arises from the fact that the algebraical sum of three harmonic alternate currents of the same period and maximum amplitude but differing by 120° in

<sup>1</sup> Continued from vol. xliiv. p. 619.



phase is always nought. This may be easily proved thus: the values of three such currents are given at any moment by projecting on a stationary line, POQ (Fig. 21), the three equal limbs of the three-legged figure  $Oa, O\beta, O\gamma$ , as it rotates with uniform velocity round the point O.  $Oa, O\beta, O\gamma$ , are, therefore, the maximum values of the three cur-

struction be made for Fig. 21,  $\zeta$  and O will always coincide, therefore the sum of the projections of  $Oa, O\beta$ , and  $O\gamma$ , Fig. 21, must be always nought.

Fig. 23 shows three curves, I, II, III, drawn so as to give the values at any moment of three harmonic alternating currents each of the same altitude, H, and periodic

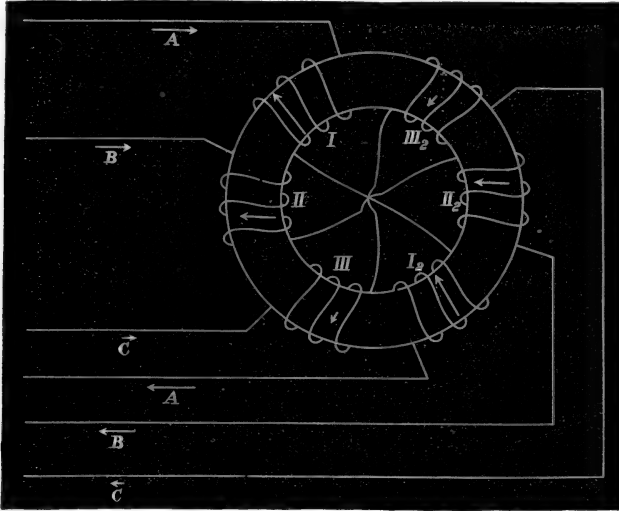

FIG. 18.—Currents differing by  $60^\circ$  in phase, and represented in direction and magnitude by the direction and length of the arrows.

rents, and the actual values of the currents for the position of the figure shown are OA, OB, OC, respectively, corresponding in relative magnitude with the lengths of the arrows which are attached to A, B, C, in Figs. 18 and 20, and in direction with the arrows attached to the latter figure, on the assumption that a current is regarded as

time, but differing by  $120^\circ$  in phase, and it is seen that the sum of the three ordinates—that is, the ordinate of the top curve—varies from  $H + 2H \sin 30^\circ$ , when the time equals  $t$ , to  $2H \sin 60^\circ$ , when the time equals  $t'$ , so that the ordinate of the summation curve varies from  $2H$  to  $\sqrt{3}H$ , corresponding with a variation of 14 per cent. But this

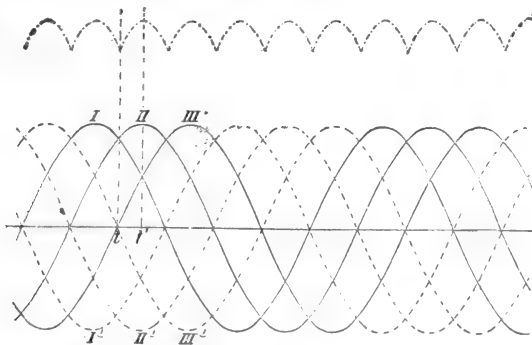

FIG. 19.—Three harmonic alternating currents of the same period and maximum altitude, but differing by  $60^\circ$  in phase.

positive when it circulates round the iron ring in such a direction as to tend to send a north pole counter-clockwise round the iron ring. Now the sum of the projections on POQ of any three lines  $Oa, O\beta, O\gamma$  (Fig. 22) is simply the projection of  $O\zeta$  found by drawing  $ae$  and  $e\zeta$  parallel and equal to  $O\beta$  and  $O\gamma$  respectively. But if such a con-

struction is exactly the variation that we obtained in Fig. 19, hence if there be twice as many convolutions in each of the three coils of Fig. 20, as in each of the six coils of Fig. 18—that is, the same total number of coils in the whole ring—and if the three equal harmonic alternating currents differing by  $120^\circ$  in phase have each the same

maximum amplitude as the three equal harmonic alternating currents differing by  $60^\circ$  in phase, there will be the same maximum variation in the number of ampere-turns in the two cases.

Mr. Dolivo Dobrowolski, the designer of the three-phase

proportional to the magnetizing force; secondly, from the magnetic leakage in the motor being different when the axis of the rotating field cuts the ring between two of the coils, and when it passes through a coil conveying a current, a case which cannot, of course, be neglected

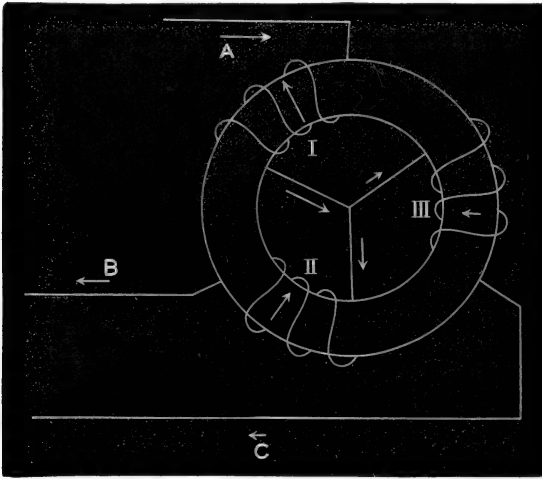

FIG. 20.—Three-phase alternate current motor (open winding); currents differing by  $120^\circ$  in phase, and represented in direction and magnitude by the direction and length of the arrows.

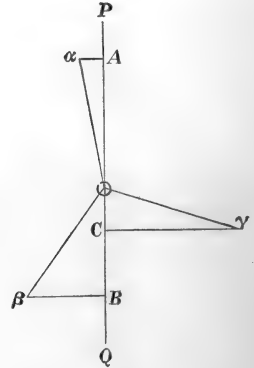

FIG. 21.

motor employed in the Lauffen-Frankfort transmission, was the first to draw attention to this variation in the number of ampere-turns with a rotatory magnetic field motor, and the pulsation of the field thus produced. But we venture to think that in his deductions he lays too much stress on the mere variation in the number of

when each coil occupies a considerable portion of the ring, as in an actual three-coil motor.

Hence we doubt whether it could be decided theoretically without experiment with which of the windings indicated in Figs. 12 or 20 the rotating magnetic field would undergo the greater variation in strength, if in

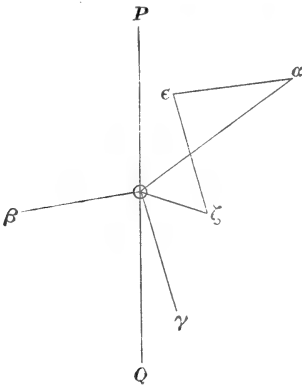

FIG. 22.

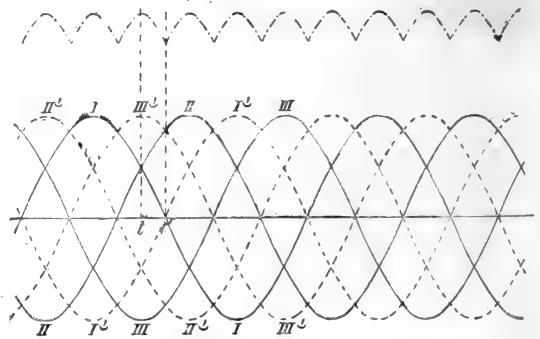

FIG. 23.—Three harmonic alternating currents of the same period and maximum altitude, but differing by  $120^\circ$  in phase.

ampere-turns, and too little on the fact that the variation in the number of ampere-turns only imperfectly indicates the variation in the strength of the rotating field. That the one variation does not alone measure the other arises first from the induction in iron not being, as is well known,

both cases the windings occupied the whole of the iron ring.

Since, as we have proved, the algebraical sum of the three alternate currents in the coils I, II, III, Fig. 20, is always nought, Kirchoff's second law suggests that these

three coils, instead of being wound on the ring as indicated in Fig. 20, may be wound so as to form a closed circuit, as shown in Fig. 24. With this arrangement of coils it is easy to show that the current

$$\begin{aligned} \text{in I} &= \frac{A+B}{3}, \\ \text{,, II} &= \frac{B-C}{3}, \\ \text{,, III} &= \frac{C+A}{3}, \end{aligned}$$

where A, B, and C represent simply the arithmetical values of the currents in the three main leads. And in Fig. 24 the arrows attached to the wires A, B, and C, and to the coils I, II, III, are drawn of such proportional lengths that the above connection between the currents

Since the three coils both for the open and the closed methods of winding (Figs. 20 and 24) are connected together, and since the current in any one coil varies like the current in the preceding coil, with a lag of 120°, each value of the current may be regarded as travelling round the ring from each coil to the next. This idea has led Mr. Dobrowski to call such a motor a rotatory current or "drehstrom" motor.

In joining up a three-phase *drehstrom* motor, we have to decide whether we shall adopt the arrangement shown in Fig. 20 or that illustrated in Fig. 24. The latter, or closed winding, would be employed when we desired that the maximum potential difference between the terminals of any one of the three coils should be equal to the maximum potential difference between any two of the mains; while with the open method of winding (Fig. 20) the maximum difference of potential between the terminals of any one of the three coils would be only  $\frac{1}{\sqrt{3}}$ , or 0.5744

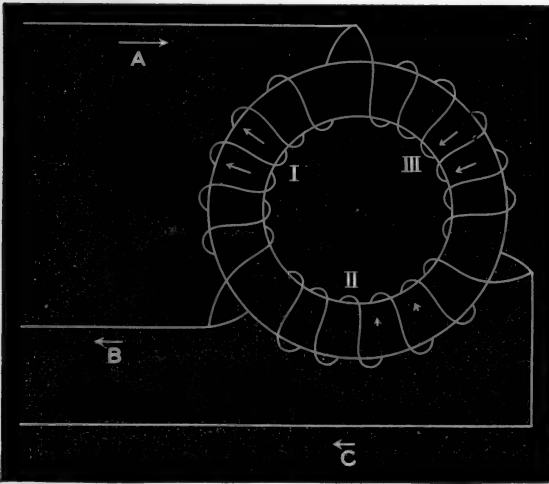

FIG. 24.—Three-phase alternate current motor (closed winding); currents differing by 120° in phase, and represented in direction and magnitude by the direction and length of the arrows.

in the three coils and the currents in the three mains is satisfied.

Next, to find the difference in phase, we draw three lines, so that their projections on POQ (Fig. 25) represent in direction and magnitude  $\frac{OA+OB}{3}$ ,  $\frac{OB-OC}{3}$ ,  $\frac{OC+OA}{3}$ , which is done by taking one-third of the diagonals of each of three parallelograms constructed respectively on  $Oa$  and  $O\beta$  produced backwards, on  $O\beta$  and  $O\gamma$  produced backwards, and on  $O\gamma$  and  $Oa$  produced backwards. In this way is obtained the three-legged figure,  $O1, O2, O3$ , with three equal sides making angles of 30° with  $Oa, O\beta, O\gamma$ , respectively; then  $O1, O2, O3$ , the projections of  $O1, O2,$  and  $O3$  on  $POQ$ , give us the direction and magnitude of the three currents in the coils I, II, III (Fig. 24). Hence we see that the current in coil I lags 30° behind the current in A, the current in coil II 30° behind the current in B, and similarly the current in coil III 30° behind the current in C.

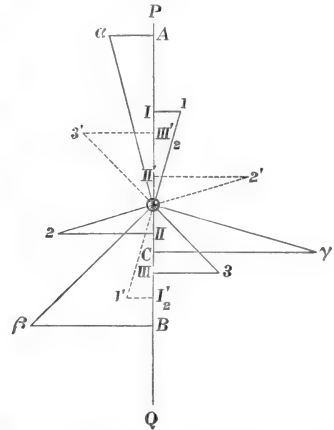

FIG. 25.—Projections of  $Oa, O\beta, O\gamma$  give direction and relative magnitude of currents in the mains A, B, C of Figs. 20, 24, 27, 29, and 31, and of currents in coils I, II, III of Fig. 20. Projections of  $O1, O2, O3$  completely represent currents in coils I, II, III of Fig. 24; and projections of  $O1, O2, O3$  completely represent currents in coils I, II, III of Fig. 27.  $\frac{1}{3}$

times the maximum potential difference between any two of the mains. The open method has the further advantage that the middle point where the single current branches into two (Fig. 20) can be permanently connected with the earth; so that, while the maximum potential difference between each pair of mains may be, say, 20,000 volts, the potential of no point of the whole system can ever differ from that of the earth by more than 10,000 volts, a result which of course enables the insulation of separate aerial conductors to be more easily carried out.

The open method of winding has therefore been adopted for the transformers at Lauffen and at Frankfort, as well as for the motor at Frankfort; but, for the reasons which follow, the actual winding employed is more complex than that indicated in Fig. 20.

In addition to the defect possessed by the two-phase alternate current motor arising from the variation in the strength of the rotating magnetic field, there is another defect caused by the rotation of the field not proceeding

at a uniform rate, so that the driving force is intermittent. Both these defects, however, can be much lessened by subdividing up the coils wound on the iron ring of the motor, a result that can be attained without increasing the number of main wires beyond three by employing the following device. Imagine one half of each of the three coils of

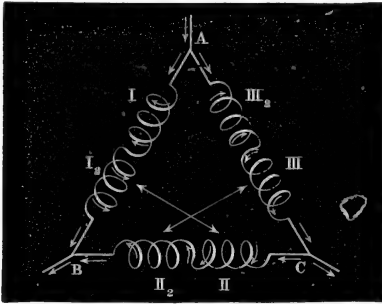

FIG. 26.—Transformation of a three-phase alternate current motor (closed winding), with currents differing by 120° in phase, into a six-phase motor, with currents differing by 60° in phase.

the motor in Fig. 24 to be wound in the opposite direction; then an arrangement, symbolically indicated in Fig. 26, would be obtained, where the six halves of the former three coils, I, II, III, are now called I, I<sub>2</sub>, II, II<sub>2</sub>, III, and III<sub>2</sub>, as we go round the triangle, Fig. 26. If now, with-

but as one-half of the coil is wrapped one way round the iron ring, and the other half the other way, the currents, as far as sending a north pole round the ring is concerned, will have diametrically opposite effects—that is, will differ by 180° in phase. Hence, while the currents in the three coils I, II, III, in Fig. 24, differed by 120° in phase, the currents in the six coils I, II, III, I<sub>2</sub>, II<sub>2</sub>, III<sub>2</sub> (Fig. 27) will differ by 60° in phase, so that, as far as the magnetization of the iron ring is concerned, we have arrived at exactly the arrangement of currents shown in Fig. 18. There is, however, this important difference—that, whereas in Fig. 18 six main wires were required, in Fig. 27 only three are needed.

The difference in phase between the currents in the six coils (Fig. 27) and the currents in the mains can be at once obtained from Fig. 25. For it is easy to show that the current

$$\begin{aligned} \text{in } I &= \frac{A+B}{3}, \\ \text{,, } II &= \frac{B-C}{3}, \\ \text{,, } III &= \frac{C+A}{3}, \end{aligned}$$

where A, B, and C represent simply the arithmetical values of the currents in the three main leads. Arithmetically, then, for the same currents in the mains A, B, C, the currents in the three coils I, II, III of Fig. 27 are the same as the currents in the three coils I, II, III of Fig. 24. But while, as far as sending north polarity counter-clockwise round the iron ring is concerned, the current in coil II of Fig. 24 was negative, that in coil II of

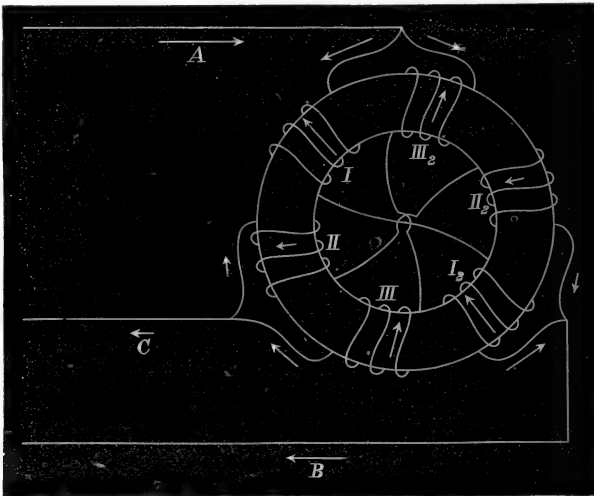

FIG. 27.—Six-phase alternate current motor (closed winding); currents differing by 60° in phase, and represented in direction and magnitude by the direction and length of the arrows.

out separating any of the connections, the coils I<sub>2</sub> and II be made to change places, as well as II<sub>2</sub> and III, we obtain the arrangement of winding shown on the motor in Fig. 27.

Now it is to be observed that since the coils I and I<sub>2</sub> (Fig. 27) are in series, being in fact simply parts of the same coil I of Fig. 26, the current in the one must be, of course, exactly the same as the current in the other;

Fig. 27 is positive. Hence, while it was the projection of O<sub>2</sub> (Fig. 25) that gave the current in coil II of Fig. 24, it will be the projection of O<sub>2</sub>' that will completely represent the current in coil II of Fig. 27, &c.

Hence, in Fig. 27 the current in the coil I will be O I, the projection of O<sub>1</sub>; the current in the coil II will be O II, the projection of O<sub>2</sub>'; that in coil III will be O III, the projection of O<sub>3</sub>; that in coil I<sub>2</sub> will be O I<sub>2</sub>, the projection of

or, &c. And the various arrows attached to the various parts of Fig. 27 are all drawn so as to represent, in direction and by their proportional lengths, the currents as determined from Fig. 25.

If, instead of starting with the closed circuit three-phase motor (Fig. 24), we deal in the same sort of way

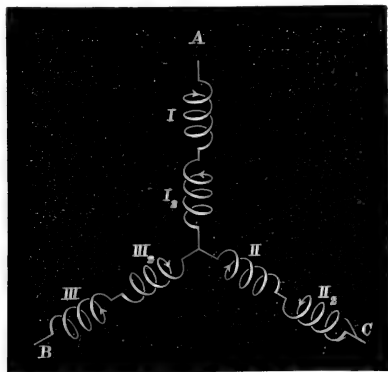

FIG. 28.—Transformation of a three-phase alternate current motor (open winding), with currents differing by  $120^\circ$  in phase, into a six-phase motor, with currents differing by  $60^\circ$  in phase.

with the open circuit three-phase motor (Fig. 20), we obtain Fig. 28, by supposing each coil to consist of two coils in series oppositely wound; and then, by interchanging the positions of the coils without breaking any of the connections, we arrive at the six-phase motor seen

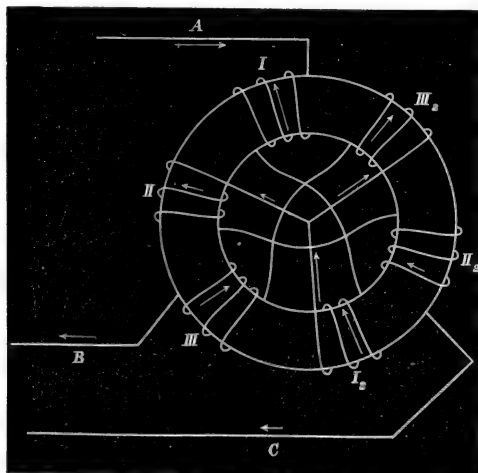

FIG. 29.—Six-phase alternate current motor (open winding); currents differing by  $60^\circ$  in phase, and represented in direction and magnitude by the direction and length of the arrows.

in Fig. 29, where the current in coil I is completely represented by  $Oa$  (Fig. 25), that in coil II by the projection of  $O\gamma$  produced backwards, that in coil III by the projection of  $O\beta$ , &c.

Lastly, if we combine the closed and open methods of

winding, and consider each coil as consisting of two in series but wound in opposite directions, we arrive at the symbolical Fig. 30; then, by interchanging the positions of the coils without separating any of the connections, the twelve-phase motor shown in Fig. 31 is produced,

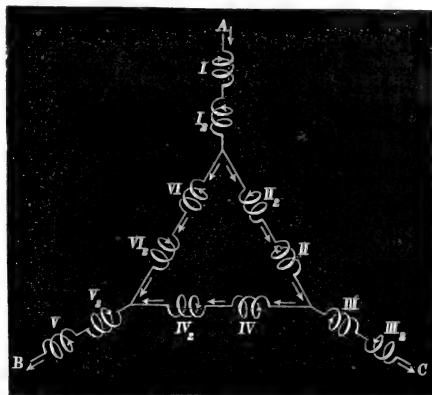

FIG. 30.—Transformation of an open wound combined with a closed wound six-phase alternate current motor into a twelve-phase motor with current differing by  $30^\circ$  in phase.

where the current in each coil differs from that in the preceding by  $30^\circ$  in phase.

In the twelve-phase motor (Fig. 31) the current in coil I is completely represented by the projection of  $Oa$  (Fig.

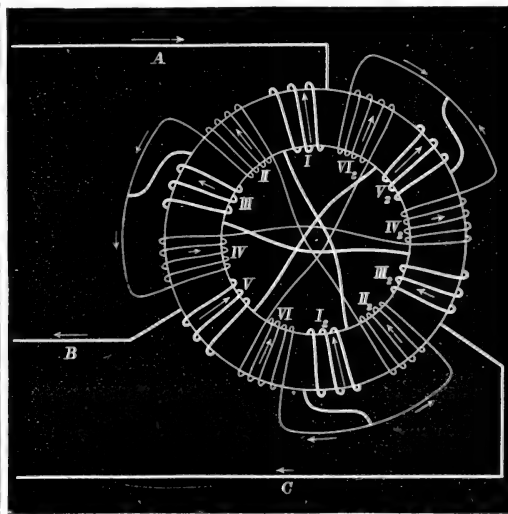

FIG. 31.—Twelve-phase alternate current motor; currents differing by  $30^\circ$  in phase and represented in direction and magnitude by the direction and length of the arrow.

25), that in coil II by the projection of  $O3'$ , that in coil III by the projection of  $O\gamma$  produced backwards, that in coil IV by the projection of  $O2$ , &c. The maximum currents then in the coils I,  $I_2$ , IV,  $IV_2$ , VI,  $VI_2$ , will

be only  $\frac{1}{\sqrt{3}}$ , or 0.5774 times the maximum value of the currents in I, I<sub>2</sub>, III, III<sub>2</sub>, V, V<sub>2</sub>. Hence the number of convolutions in each of the coils II, II<sub>2</sub>, IV, IV<sub>2</sub>, VI, VI<sub>2</sub> should be  $\frac{2}{3}$  of the number in each of the coils I, I<sub>2</sub>, III, III<sub>2</sub>, V, V<sub>2</sub>, and the cross-section of the wire in each of the first six coils only  $\frac{2}{3}$  of that in the last six, both of which ratios are symbolically indicated in Fig. 31.

By still further following out the same general idea, an alternate current motor with twenty-four, or more, coils on it can be developed, requiring only three main wires to supply the current. And thus, thanks to the labours of Tesla, Bradley, Haselwander, Wenström, and last, but by no means least, to the striking ingenuity of Dolivo Doblowsky, a practical alternate current motor can now be constructed, which will produce as steady a driving force as the best modern direct current motor.

W. E. A.

(To be continued.)

### THE IMPLICATIONS OF SCIENCE.<sup>1</sup>

I.

WHEN I was honoured by an invitation to lecture here this evening, I felt much troubled as to the subject which I might most fitly select as my theme. During the forty years I have been a member of the Royal Institution, I have had the privilege of listening to lectures on many very different branches of science, and I know that all branches of science have few or many followers amongst the audience I am now addressing.

It has struck me, however, that for this single lecture it might be well not to confine myself to any subordinate department of scientific inquiry, but rather to invite your attention to certain questions which deeply concern them all. Thus, it has seemed to me, I might hope to interest a greater number of hearers than it would be possible for me otherwise to do.

I felt the more encouraged to take this course when I recalled to mind on how many previous occasions I had myself listened to discourses of a similar breadth of scope, given in this theatre by very distinguished men of science.

Foremost among them I may mention Prof. Huxley, who has here, as elsewhere, called attention to questions which underlie all physical science. I may also refer to that brilliant mathematician, Prof. Clifford, the sad and sudden ending of whose brief career we have good reason to deplore.

It would be easy to mention the names of other scientific celebrities who have here discoursed on matters beyond the scope of any one branch of science. These two, however, will, I think, suffice.

But before proceeding further I would feign say a few words as to the title of my lecture, so as at once to prevent any misunderstanding as to the object I have in view.

By "*the implications of science*," I mean nothing to which any section of my hearers can object, whatever their notions about "*creed*" or "*conduct*" may be. I desire carefully to eliminate all questions of either religion or morals, and I shall confine myself purely and simply to the consideration of certain propositions which appear to me to be latent within, and give force to, what we regard as well-ascertained scientific truths. They are propositions which must, I believe, be assented to by every consistent follower of science, who is convinced that science has brought to our knowledge *some* truths on which we can, with entire confidence, rely.

My appeal, then, is to the pure intellect of my hearers,

and to nothing else. And indeed I desire to take this opportunity plainly to declare, before this distinguished audience, that not only here and now, but everywhere and always, I unhesitatingly affirm that no system can, or should, stand, which is unable to justify itself to reason. I possess no faculty myself, nor do I believe that any human faculty exists, superior to the intellect, or which has any claim to limit or dominate the intellect's activity. Feelings and sentiments have their undoubted charm and due place in human life, but that place is a subordinate one, and should be under the control of right reason.

But it is by no means only or mainly against those who would undervalue *reason* in the interest of *sentiment*, that I have this evening to protest. My object is to uphold what I believe to be the just claims of our rational nature against all who, from whatever side, or in the name of whatsoever authority, would impugn its sovereign claims upon our reverence, or unduly restrict the area of its sway.

As I have already intimated, I propose to fulfil this task by calling attention to some half-dozen far-reaching truths implicitly contained in scientific doctrines universally admitted, so that those doctrines cannot logically be maintained, if such implied truths are *really* and *seriously* doubted, and still less if they are *really* disbelieved and denied. These truths, then, are what I mean by "*the implications of science*." But what *is* science?

The word "*science*" is now very commonly taken as being synonymous with "*physical science*." There is much to be said against giving the word so narrow a meaning; nevertheless that meaning will sufficiently serve my purpose this evening. "*Science*," then, thus understood, is merely ordinary knowledge pursued with extreme care—most careful observation, measuring, weighing, &c.—together with most careful reasoning as to the results of observations and experiments, and also painstaking verification of any anticipations which may have been hazarded. In this way our thoughts are made to conform as accurately as may be with what we regard as the realities they represent.

The value and the progress of science are unquestioned. Many foolish discussions are carried on in the world about us; but certainly no one disputes or doubts the value of science or the fact of its progress. The value of carefully ascertained scientific truths will not at any rate be disputed in *this* theatre, which has witnessed the triumphs of the immortal Faraday, and which may justly claim to be a very temple of science. And certainly I have no disposition to undervalue it, who have loved it from my earliest years, and devoted such small powers as I possess to its service. I am profoundly convinced that, since I can recollect, biological science has made great progress, and I see grounds for absolute certainty now about many propositions in zoology which were doubtful or undreamed of when I was a lad.

We all, then, agree that science does advance. Nevertheless, it is obvious that such advance would be impossible if we could not, by observations, experiments, and inferences, become so certain with respect to *some* facts as to be able to make them the starting-points for fresh observations and inferences as to other facts. Thus, with respect to the world we live in, most educated men are now certain as to its daily and annual revolutions, as also that its crust is largely composed of sedimentary rocks, containing remains or indications of animals and plants more or less different from those which now live. No one can reasonably deny that we may rely with absolute confidence and entire certainty upon a variety of such assertions.

But our scientific certainties have been acquired more or less laboriously, and a questioning attitude of mind is emphatically the scientific attitude. We ought never to

<sup>1</sup> Friday Evening Discourse delivered at the Royal Institution by Dr. St. George Mivart, on June 5, 1891.

rest satisfied about any scientific inquiry the truth of which has not been demonstrated, unless we find that it is one which we have no possible power to answer. It would obviously be idle to occupy ourselves about the shape or number of the mountains on that side of the moon which is constantly turned away from us.

Yet, although doubt and inquiry are necessary in science, nevertheless doubt has its legitimate limits. Blind disbelief is scientifically fatal, as well as blind belief. We all know how apt men are, when seeking to avoid one extreme, to fall into the opposite one, and it is possible to get into an unhealthy condition of mind so as to be unable to give a vigorous assent to anything. It is necessary distinctly to recognize there is such a thing as *legitimate* certainty, not to perceive the force of which is *illegitimate* doubt. Such doubt would necessarily discredit all physical science.

*Universal* doubt, for example, is an absurdity. It is scepticism run mad.

If anyone affirms that "nothing is certain," he obviously contradicts himself, since he thereby affirms the certainty of uncertainty. He says that, which, if true, absolutely contradicts what he has declared to be true.

But a man who affirms what the system he professes to adopt forbids him to affirm, and who declares that he believes what he also declares to be unbelievable, should hardly complain if he is called "foolish." No system can be true, and no reasoning can be valid, which inevitably ends in absurdity. Such scepticism, then, cannot be the mark of an exceptionally intellectual mind, but of an exceptionally foolish one, and every position which necessarily leads to scepticism of this sort must be an untenable position.

A very little reflection suffices to show how self-refuting such modes of thought are.

Thus, if a man were to say, "I cannot know anything because I cannot be sure that my faculties are not always fallacious," or "I cannot be sure of anything because, for all I know, I may be the plaything of a demon who amuses himself by constantly deceiving me"—in both these cases he contradicts himself, because he obviously grounds his assertion upon his perception of the truth that "we cannot arrive at conclusions which are certain by means of premises which are uncertain or false."

But if he knows that truth, he must know that his faculties are not always fallacious, and that his demon cannot deceive him in everything.

My object in making these remarks is to enable us to get clear of mere idle, irrational doubts which have no place in science and can have none, so that we may recognize the fact that we all of us have certainty as to some facts according to our degrees of knowledge. Obviously we can only judge of truth by our mental faculties, and if a man denies their validity we must pass him by, contenting ourselves with calling his attention to the fact that he refutes himself. If a man professes to doubt his faculties, or to doubt whether language can be trusted to convey thought, then plainly we cannot profitably argue with him. But if, on account of his absurdity, we cannot refute him, it is no less plain that he cannot defend his scepticism. Were he to attempt to do so, then he would show, by that very attempt, that he really had confidence in reason and in language, however he might verbally deny it.

Confident, then, that there are some scientific statements on which we may rely with *certainty*, let us consider a few truths implicitly contained in them.

In the first place, science makes use not only of observations and experiments, but also of reasoning as to the results of such experiments. It needs that we should draw valid inferences; but this implies that we may, and must, place confidence in the principle of deduction—in that perception of the mind which we express by the word "therefore." When we use that word, we mean to

express by it that there is a truth, the certainty of which is shown through the help of different facts or principles which themselves are known to be true.

It is sometimes objected to deductive reasoning—that the syllogism—that it really teaches us nothing new, all that is contained in the conclusion being contained already in the premisses. But this objection is due to a want of perception of the great difference which exists between *implicit* and *explicit* knowledge. Let us suppose a person to be looking at some very flexible and soft kind of fish. He may, perhaps, say to himself, "This creature can have no spinal column!" Then it may strike him that naturalists have classed fishes, together with other animals, in a great group, one character of which is the possession of a spinal column, and so he may *explicitly* recognize a truth implied in what he knew before. So great, indeed, is the difference between explicit and implicit knowledge, that the latter may not really deserve to be called "*real knowledge*" at all. No one will affirm that a student who has merely learned the axioms and definitions of Euclid has attained such a *real knowledge* of all the geometrical truths the work contains that he will fully understand all its propositions and theorems without having to study them. Yet all the propositions, &c., of Euclid are *implicitly* contained in the definitions and axioms. Nevertheless, the student will have to go through many processes of inference by which these implicit truths may be explicitly recognized by him, before he can be said to have any *real knowledge* of them.

The VALIDITY OF INFERENCE is, then, one of the truths implied by physical science, and we shall presently see the intellectual penalty which must be paid for any *real* doubt about it.

In the second place, physical science is emphatically experimental science. But every experiment, carefully performed, implies a most important latent truth. For when an experiment has shown us that anything is certain—as, for example, that a newt's leg may grow again, after amputation, because one actually has grown again; we shall find that such certainty implies a prior truth. It implies the truth that if the newt has come to have four legs once more, it cannot at the very same time have only three legs. This may seem too trivial a remark to some of my hearers, but there is nothing like a *concrete* example for making an *abstract* truth plain. Anything we are certain about, because it has been proved to us by experiment, is certain only if we know, and because we know, that a thing which has been actually proved cannot at the same time remain unproven. If we reflect again on this proposition, we shall see that it depends on a still more fundamental truth which our reason recognizes—the truth, namely, that "nothing can at the same time both be and not be"—the truth known as "THE LAW OF CONTRADICTION"; and this I bring forward as a second truth implied by physical science.

If we reflect upon this law, we shall see that our intellect recognizes it as an absolute and necessary truth which carries with it its own evidence. It is but the summing up in one general expression, of all the concrete separate cases—such as that of the newt's legs, of the fact that if a man possesses two eyes he cannot at the same time have only one, and so on.

But an objection has been made as follows: "It is very true that I cannot imagine having 'two eyes' and only 'one eye' at the same time, and so I must practically acquiesce in the statement, but I am only compelled to do so by the impotence of my imagination." Thus, instead of the "law of contradiction," Mr. Herbert Spencer has put forward as an ultimate truth—"his universal postulate"—the assertion that "we must accept as true propositions we cannot help thinking, because we cannot imagine the contrary." But if any of my hearers will reflect over what his mind tells him when it pronounces

that he cannot at the same time have both two eyes and only one eye; he will, I think, see that his perception is (as *mine* is) a perception of real incompatibility, and consequent positive impossibility. He will not find his mind a mere blank, passively unable to imagine something. He will find that his mind actively asserts its power to judge of the matter as well as what its judgment is, and that the truth is one which positively applies to *things*, and not merely to his own imaginings.

Moreover, this objection ignores the difference between intellect and imagination. Yet there are very many things we can conceive of but cannot imagine, as, for example, our "act of sight" or "our own annihilation."

But it appears to me evident that Mr. Herbert Spencer's "universal postulate" can never be itself an ultimate truth, but must depend upon the law of contradiction. For, supposing we had tried to imagine a thing and *failed*, how could we from that ever be sure we might not at the same time have actually tried and *succeeded*, if we could not rely upon the law of contradiction?

The consequences resulting from any real doubt as to this law we will see later on.

In the pursuit of science, observation is anterior to experiment; but in every observation in which we place confidence, and still more in every experiment, a third fundamental truth is necessarily implied: this implied truth is the VALIDITY OF OUR FACULTY OF MEMORY.

It is plain that it would be impossible for us to be certain about any careful observation or any experiment, if we could not feel confidence in our memory being able to vouch for the fact that we had observed certain phenomena and what they were. But what is memory?

Evidently we cannot be said to remember anything unless we are conscious that the thing we so remember has been present to our mind on some previous occasion. A mental image might present itself to our imagination a hundred times; but if at each recurrence it seemed to us something altogether new, and unconnected with the past, we could not be said to *remember* it. It would rather be an example of extreme forgetfulness than of memory.

By asserting the trustworthiness of our faculty of memory, I do not, of course, mean that we may not occasionally make mistakes about the past. It is quite certain we may, and do, make such mistakes. But, nevertheless, we are all of us certain as to *some* past events. Probably there is no single person now in this room who is not certain that he was somewhere else before he entered it. Memory informs us—certainly it informs *me*—as surely concerning *some* portions of the past, as consciousness does concerning *some* portions of the present.

If we could not trust our faculty of memory, the whole of physical science would be, for us, a mere present dream. But there can be no such thing as *proof* of the trustworthiness of memory, since no argument is possible without trusting to the veracity of memory. It is therefore a fundamental fact which must be taken on its own evidence, and from a consideration of the results of any real doubt about it—results I will refer to presently.

Yet it has been strangely declared, by a leading agnostic, that we may trust our memory because we learn its trustworthiness by experience. Surely never was fallacy more obvious! How could we ever gain experience if we did not trust memory in gaining it? Particular acts of memory may, of course, be confirmed by experience if the *faculty* of memory be already trusted, but in every such instance it must be confided in. The agnostic referred to has told us in effect that we may place confidence in our present memory because in past instances its truth has been experimentally confirmed, while we can only know it *has* been so confirmed by trusting our present memory!

But if we admit the trustworthiness of memory at all, a most important consequence follows—one relating to the

distinction between what is *subjective* and what is *objective*.

Every feeling or state of consciousness present to the mind of the subject who possesses it is "subjective," and the whole of such experiences taken together constitute the sphere of *subjectivity*. Whatever is external to our present consciousness or feelings is for us "objective," and all that is thus external is the region of OBJECTIVITY. Now memory, inasmuch as it reveals to us part of our own past, reveals to us what is "objective," and so introduces us into the realm of objectivity, shows us more or less of objective truth, and carries us into a real world which is beyond the range of our own present feelings. This progress, then, this knowledge of *objectivity*, is, through memory, IMPLIED in every scientific experiment the facts of which we regard as certain.

But our scientific observations and experiments carry with them yet another implication more important still: this is the certainty of our KNOWLEDGE OF OUR OWN CONTINUOUS EXISTENCE. Unless we can be sure that we actually made the observations and experiments, on our having made which we rely for our conclusions, how can those conclusions be confidently relied on by us?

This implication is so important—in my opinion so *fundamentally* important—that I must crave your permission to notice it, later on, at some length. But before considering it, I desire to call your attention to the fact that the propositions thus implied by physical science, run directly counter to a system of thought which is widely current to-day, and which has now and again found expression in this theatre. The popular views I refer to may be conveniently summed up as follows:—

(1) All our knowledge is merely relative.

(2) We can know nothing but phenomena.

(3) We have no supremely certain knowledge but that of our own feelings, and therefore we have none such of our continuous existence.

(4) We cannot emerge from subjectivity, or attain to real knowledge of anything objective.

Therefore, either I am very much mistaken, or those who uphold the views I have just summed up are much mistaken.

It may seem presumptuous on my part to come forward here to-night to controvert a system upheld by men of such undoubted ability and so unquestionably competent in science, as are men who uphold the system I oppose. I feel therefore that a few words of personal apology and explanation are due from me.

For full five-and-thirty years I have been greatly interested in such questions. But when my intellectual life began, it was as a student and disciple of that school with which the names of John Stuart Mill, Alexander Bain, G. H. Lewes, Herbert Spencer, and Prof. Huxley have been successively associated—more or less closely. The works of writers of that school I studied to the best of my ability, and I had the advantage of personal acquaintance with some of the more distinguished of them. Thus, by conversation, I was much better enabled to learn what their system was than I could have learned it by reading only.

However, by degrees, I became sceptical about the validity of the system I had at first ingenuously adopted, but it took me not a few years to clearly see my way through all the philosophical fallacies—as I now regard them—in which I found myself entangled. I say "see my way through," for I did not free myself from them by *drawing back* but by *pushing forwards*—slowly working my way through them and out on the other side. These circumstances constitute my apology for appearing before you as I do. I have been a dweller in the county which I am willing to aid anyone to explore who may wish to explore it.

(To be continued.)



## ELECTRICITY IN RELATION TO SCIENCE.

THE third annual dinner of the Institution of Electrical Engineers was held at the Criterion on Friday, November 13. Prof. William Crookes, the President, was in the chair. In proposing the toast of the evening, "Electricity in relation to Science," Prof. Crookes delivered the following speech:—

We have happily outgrown the preposterous notion that research in any department of science is mere waste of time. It is now generally admitted that pure science, irrespective of practical applications, benefits both the investigator himself and greatly enriches the community. "It blesseth him that gives, and him that takes." Between the frog's leg quivering on Galvani's work-table and the successful telegraph or telephone there exists a direct filiation. Without the one we could not have the other.

We know little as yet concerning the mighty agency of electricity. "Substantialists" tell us it is a kind of matter. Others view it, not as matter, but as a form of energy. Others, again, reject both these views. Prof. Lodge considers it "a form, or rather a mode of manifestation, of the ether." Prof. Nikola Tesla demurs to the view of Prof. Lodge, but thinks that "nothing stands in the way of our calling electricity ether associated with matter, or bound ether." High authorities cannot even yet agree whether we have one electricity or two opposite electricities. The only way to tackle the difficulty is to persevere in experiment and observation. If we never learn what electricity is, if, like life or like matter, it should remain an unknown quantity, we shall assuredly discover more about its attributes and its functions.

The light which the study of electricity throws upon a variety of chemical phenomena—witnessed alike in our little laboratories and in the vast laboratories of the earth and the sun—cannot be overlooked. The old electrochemical theory of Berzelius is superseded, and a new and wider theory is opening out. The facts of electrolysis are by no means either completely detected or co-ordinated. They point to the great probability that electricity is atomic, that an electrical atom is as definite a quantity as a chemical atom. The electrical attraction between two chemical atoms being a trillion times greater than gravitational attraction is probably the force with which chemistry is most deeply concerned.

It has been computed that, in a single cubic foot of the ether which fills all space, there are locked up 10,000 foot-tons of energy which have hitherto escaped notice. To unlock this boundless store and subdue it to the service of man is a task which awaits the electrician of the future. The latest researches give well-founded hopes that this vast storehouse of power is not hopelessly inaccessible. Up to the present time we have been acquainted with only a very narrow range of ethereal vibrations, from extreme red on the one side to ultra-violet on the other—say from 3 ten-millionths of a millimetre to 8 ten-millionths of a millimetre. Within this comparatively limited range of ethereal vibrations, and the equally narrow range of sound vibrations, we have been hitherto limited to receive and communicate all the knowledge which we share with other rational beings. Whether vibrations of the ether, slower than those which affect us as light, may not be constantly at work around us, we have until lately never seriously inquired. But the researches of Lodge in England, and Hertz in Germany, give us an almost infinite range of ethereal vibrations or electrical rays, from wave-lengths of thousands of miles down to a few feet. Here is unfolded to us a new and astonishing universe—one which it is hard to conceive should be powerless to transmit and impart intelligence.

Experimentalists are reducing the wave-lengths of the electrical rays. With every diminution in size of the

apparatus the wave-lengths get shorter, and could we construct Leyden jars of molecular dimensions the rays might fall within the narrow limits of visibility. We do not yet know how the molecule could be got to act as a Leyden jar; yet it is not improbable that the discontinuous phosphorescent light emitted from certain of the rare earths, when excited by a high-tension current in a high vacuum, is really an artificial production of these electrical rays, sufficiently short to affect our organs of sight. If such a light could be produced more easily and more regularly, it would be far more economical than light from a flame or from the arc, as very little of the energy in play is expended in the form of heat rays. Of such production of light, Nature supplies us with examples in the glow-worm and the fire-flies. Their light, though sufficiently energetic to be seen at a considerable distance, is accompanied by no liberation of heat capable of detection by our most delicate instruments.

By means of currents alternating with very high frequency, Prof. Nikola Tesla has succeeded in passing by induction through the glass of a lamp energy sufficient to keep a filament in a state of incandescence without the use of connecting wires. He has even lighted a room by producing in it such a condition that an illuminating appliance may be placed anywhere and lighted without being electrically connected with anything. He has produced the required condition by creating in the room a powerful electrostatic field alternating very rapidly. He suspends two sheets of metal, each connected with one of the terminals of the coil. If an exhausted tube is carried anywhere between these sheets, or placed anywhere, it remains always luminous.

The extent to which this method of illumination may be practically available experiments alone can decide. In any case, our insight into the possibilities of static electricity has been extended, and the ordinary electric machine will cease to be regarded as a mere toy.

Alternating currents have at the best a rather doubtful reputation. But it follows from Tesla's researches that as the rapidity of the alternation increases they become not more dangerous but less so. It further appears that a true flame can now be produced without chemical aid—a flame which yields light and heat without the consumption of material and without any chemical process. To this end we require improved methods for producing excessively frequent alternations and enormous potentials. Shall we be able to obtain these by tapping the ether? If so, we may view the prospective exhaustion of our coal-fields with indifference; we shall at once solve the smoke question, and thus dissolve all possible coal-rings.

Electricity seems destined to annex the whole field not merely of optics, but probably also of thermotics.

Rays of light will not pass through a wall, nor, as we know only too well, through a dense fog. But electrical rays of a foot or two wave-length of which we have spoken will easily pierce such mediums, which for them will be transparent.

Another tempting field for research, scarcely yet attacked by pioneers, awaits exploration. I allude to the mutual action of electricity and life. No sound man of science endorses the assertion that "electricity is life"; nor can we even venture to speak of life as one of the varieties or manifestations of energy. Nevertheless electricity has an important influence upon vital phenomena, and is in turn set in action by the living being—animal or vegetable. We have electric fishes—one of them the prototype of the torpedo of modern warfare. There is the electric slug which used to be met with in gardens and roams about Hornsey Rise; there is also an electric centipede. In the study of such facts and such relations the scientific electrician has before him an almost infinite field of inquiry.

The slower vibrations to which I have referred reveal

the bewildering possibility of telegraphy without wires, posts, cables, or any of our present costly appliances. It is vain to attempt to picture the marvels of the future. Progress, as Dean Swift observed, may be too fast for endurance. Sufficient for this generation are the wonders thereof.

#### GEOLOGICAL PHOTOGRAPHS.

AT the meeting of the British Association in 1889, a Committee was appointed for the purpose of arranging for the collection, preservation, and systematic registration of photographs of geological interest in the United Kingdom. Since its formation, the Committee has succeeded in obtaining a number of photographs, 588 of which were received and registered up to August last; and in its second report, presented at the Cardiff meeting of the British Association, the Committee was able to state that, in the choice of subjects, greater care had been taken during the year to include the most typical views. As yet, only about half of the British counties are represented in the collection, while some are still represented inadequately. The work is one of great interest and importance, both from a scientific and an educational point of view, and it may be hoped that local Societies and Field Clubs, whose co-operation the Committee is particularly anxious to secure, will everywhere associate themselves with the scheme, and do what they can to bring it to completion. The Committee, in a circular just issued, suggests that these Societies and Clubs might materially aid the scheme by mapping out their districts under the direction of a local geologist, and drawing up a list of sections and localities of which photographs would be desirable. New sections and exposures of strata should be noted. This preliminary work could be done during the winter session, and arrangements made for the use of the camera in the ensuing spring, or when opportunity offered.

In its report, the Committee refers especially to the work accomplished by the Geological Photographic Committee of the Yorkshire Naturalists' Union. Among the photographs of this Society are many relating to sections which cannot be reproduced—as, for instance, fossil trees laid bare in quarrying and in excavations for the foundations of buildings now covered over. The Hertfordshire Natural History Society and the East Kent Natural History Society have also organized schemes for the photography of local geological features; and the Committee has already received from them views which, it is hoped, will be supplemented by a further series next year.

Of course it is not always easy to obtain the services of a professional photographer, but few Societies should have much difficulty in securing the help of amateur photographers, so many of whom are now to be found in all parts of the country. In order that there may be unity of action, the Committee has drawn up a set of instructions, copies of which may be obtained on application to the secretary, Mr. Osmund W. Jeffs, 12 Queen's Road, Rock Ferry, Cheshire. It is pointed out that the photographs should illustrate characteristic rock exposures, especially those of a typical character or temporary nature; important boulders; localities affected by denudation, or where marked physiographical changes are in operation; raised beaches; old sea-cliffs and other conspicuous instances of marine erosion; characteristic river-valleys or escarpments, and the like; glacial phenomena, such as *roches moutonnées*, moraines, drums, and kames; or any natural views of geological interest. Photographs of microscopical sections and typical hand-specimens of rocks are also admissible.

Detailed lists of photographs officially received are published in the report of the Committee, which also

states where the photographs may be obtained. Lists for insertion in the third report will be received up to June 15, 1892.

It is satisfactory to find that geological photographic schemes similar to that of the British Association are being adopted in other countries. The Committee, in its second report, alludes to the action taken in the matter by the Société Géologique de Belgique, and to the Committee of Photographs appointed by the Geographical Society of America. The American Committee proposes to prepare lists for international exchange.

#### NOTES.

AFTER a rather prolonged delay, the Commission for the delimitation of the Anglo-French frontier in the neighbourhood of Sierra Leone, in accordance with the West African agreement between Great Britain and France of August 10, 1889, has been appointed. Captain Kenney, R.E., the British Commissioner, with his party, proceeded to Sierra Leone by the steamer of November 14 last. The Secretary of State for the Colonies permitted the Director of Kew to nominate a botanist to accompany the expedition, and the Government Grant Committee of the Royal Society made a grant to meet his expenses, part of which will also be borne by the Government of Sierra Leone. The mission has been undertaken by Mr. G. F. Scott-Elliot, M.A. Camb., B.Sc. Edinb., F.L.S., who has recently published in the Journal of the Linnean Society an account of the new species of plants found by him in a journey through a little known part of Southern Madagascar. The botany of the interior of Sierra Leone is very little known, but is believed to be of great interest. The Commission will be absent about six months. It will proceed in the first instance to Falaba, and then proceed to the point of intersection of the 10th parallel of North latitude and the 13th meridian (French) of West longitude.

WE understand that Prof. Hennessy, F.R.S., will shortly resign the Chair of Applied Mathematics and Mechanism in the Royal College of Science, Dublin. The salary of the post is £400, rising to £500, a year, with a share of the fees. The appointment rests with the Lord President of the Council, and applicants should address themselves to the Secretary, Science and Art Department.

THE arrangements to be made for the Crystal Palace Electrical Exhibition are to be discussed at a meeting of the honorary council of advice and of the special committee appointed by the Electrical Section of the London Chamber of Commerce. The meeting will be held at the Mansion House on Wednesday, November 25, at 3 o'clock. The Lord Mayor will preside. The whole of the space is now practically allotted, extra buildings having been erected for certain large installations which could not otherwise have been accommodated.

A COMMITTEE has been appointed by the American Institute of Electrical Engineers to suggest plans for the International Electrical Congress to be held in Chicago in 1893, in connection with the World's Fair. A local Committee, with Prof. Gray as President, is being formed at Chicago for the purpose of making preparations for the same Congress. The Chicago journal *Electricity* sees no reason "why a perfectly harmonious arrangement should not be made between the Institute and the local Committee, whereby both will work together to promote the success of the Congress."

THE Spanish Government intend to open two Exhibitions in September 1892 in celebration of the fourth centenary of the discovery of America. One of these will be at Madrid, and will be called the Exposition Historique Américaine de Madrid. The

other, at Huelva, will be called the Exposition Historique Européenne de Madrid. The former should have considerable interest for anthropologists, as it has for its object, according to the official programme, "de présenter de la manière la plus complète l'état où se trouvaient les différentes contrées du Nouveau-Continent avant l'arrivée des Européens et au moment de la conquête, jusqu'à la première moitié du XVII<sup>e</sup> siècle." It will comprise objects, models, pictures, &c., illustrating the customs and civilization of the peoples at that time inhabiting America.

We greatly regret to have to record the death of Prof. Henry N. Moseley, F.R.S. He died on November 10, at the age of forty-six. We hope next week to give some account of his services to science.

DR. OSCAR BAUMANN is about to undertake a series of explorations in the interest of the German East Africa Company. In the German Masai territory there are, he says, in a letter to *Globus*, many regions about which little is known; and about these he hopes to bring back much fresh light. He proposes to study the conditions which must be taken into account by projectors of railways, and, if possible, to open a direct caravan route to Lake Victoria.

In the course of his interesting presidential address at the meeting of the Institution of Civil Engineers last week, Mr. Berkeley referred to the production of iron in the United States. The most conspicuous difference between American and English practice, he said, was the output from one blast furnace. The largest production in Great Britain did not seem to exceed 750 tons in the week, while in America it had reached 2000 tons. It might be questioned whether this large output from a single furnace was not obtained at some sacrifice of economy of fuel used and of wear and tear of furnace. The production of pig-iron in the United States now amounted to 10,000,000 tons, or 2,000,000 tons more than that of the United Kingdom. This amount was wholly used within the country, showing a larger quantity of iron used per head of the population (300 pounds) than in any other part of the world. In Great Britain, after deducting from its production of iron the quantity exported, the consumption only equalled 250 pounds per head of the population.

THE lecture season at the London Institution, Finsbury Circus, was opened on Monday evening with a lecture by Sir M. E. Grant Duff on "Some of our Debts to the East."

THE barometric depression on November 11, according to Mr. G. J. Symons, has been exceeded only five times in the 34 years during which he has been making meteorological observations. In a letter to the *Times* Mr. Symons says that as he anticipated some such depression, he started the Richard brontometer at 6.30 a.m., and kept it running for 10 hours—*i.e.* through the chief part of the depression. This, at the cost of a little trouble and a roll of paper, gave him a record of the motion of the barometer such as had never before been obtained—somewhere about 60 feet long—and with every little pulsation shown in detail, even if it lasted only two seconds.

WE have received the meteorological year-book published by the *Magdeburg Zeitung* for 1890, being the tenth year for which the observations have been made on a uniform plan. In addition to observations taken three times daily, the volume contains hourly values of pressure and wind, and continuous records of sunshine; also, curves of pressure and temperature for those periods of exceptional weather during which the ordinary hourly values would fail to represent the details of the oscillations—a plan which seems highly commendable. The whole work is very complete and compact.

THE Deutsche Seewarte has published a catalogue of its valuable library, containing entries of 10,660 works and excerpt papers in various subjects, about a quarter of which refer to meteorology. The library has been enriched by the acquisition of the books which formerly belonged to Prof. Dove and other eminent men. This laborious undertaking has been carried out with great care, and is classified under subjects and authors. Some difficulty has been experienced in dealing with a few English authors; *e.g.*, on p. 67, Balfour Stewart is entered under the Christian name, and on p. 160, Powell is entered as the Christian name of Baden-Powell. And the works issued by institutions are not always sufficiently distinguished from those which are due to individual writers; *e.g.*, on p. 5, Sir Thomas Farrer is credited with a work on "Telegraphic Weather Information"—of which, probably, he would have no recollection, it being merely a circular signed in his capacity as Secretary of the Board of Trade. But these are mere trifles, and in no way detract from the value of the work as a whole, for which the scientific world will be grateful.

MR. ALBERT KOEBELE, the American entomologist, is travelling in the Australasian colonies for the purpose of studying the enemies of insect pests. In introducing him to the Wellington Philosophical Society at a meeting on September 23, Sir James Hector recalled the circumstances connected with a memorable service which Mr. Koebele lately rendered to California. In 1888, when on a visit to South Australia in search of a small fly (*Testophonus*), a parasite on that dreadful pest *Icerya purchasi*, Mr. Koebele discovered a single ladybird (*Vedalia*) preying on the pest. He found a second specimen in New South Wales, and then on his arrival in New Zealand he found that the *Icerya* about Auckland was also being destroyed by something, and this, too, turned out to be *Vedalia*. He at once saw that here was the thing he sought, and he was fortunate enough to be able to collect several thousands of *Vedalias*, which he afterwards liberated in California. Up to that time California had been so eaten up by *Icerya* that the damage was estimated at twenty millions of dollars annually. Yet, in twelve or fifteen months after the liberation of *Vedalia* in April 1889, the State was practically free from the dreaded pest. Sir James Hector rightly characterized this work of Mr. Koebele as one of the grandest things in the interest of fruit and tree-growers that have been effected in modern times.

PROF. G. L. GOODALE, of Harvard University, has recently paid a visit to the Museums and Botanical Gardens in the tropics and in the southern hemisphere, and has contributed an interesting description of them to the *American Journal of Science*. In the number for October we find an account of the Technological Museum at Sydney, which contains a very complete collection of the economic vegetable products of Australia, and which is largely visited by the working classes; of the two Botanic Gardens at Brisbane, one of them under the management of the Society of Acclimatization; the Botanic Gardens at Geelong, Dunedin, Christchurch, and Wellington; the Museums at Dunedin, Christchurch, Wellington, and Auckland; and the small but excellent local Museum and Garden at Hobart. Prof. Goodale notices, with commendation, the tenacity with which all the Australian Museums cling to rare specimens of archæological and ethnographical interest, instead of utilizing them for exchange.

MESSRS. MACMILLAN AND CO. have published the first number of the *Record of Technical and Secondary Education*, a bi-monthly journal of the progress made by County Councils and other local authorities in the administration of the Technical Instruction Acts. The periodical is issued on behalf of the National Association for the Promotion of Technical and Secondary Education. Lord Hartington contributes an intro-

ductory statement, in which he sets forth briefly the objects of the *Record*. It will, he says, be of a strictly practical character, and will not interfere with any educational journal now in circulation. It will "give the latest information, not only with respect to what is being done in this Kingdom, but also in regard to such educational work on the Continent and in America as may be of service to those who are engaged in carrying out schemes of technical instruction." The *Record* may become a journal of great value, and we trust there will be a cordial response to Lord Hartington's appeal to the members of the County Councils, their organizing secretaries, and others interested in the work, to supply the Committee with early and regular information as to what is being done in their several centres. The present number contains, besides Lord Hartington's statement, County Council schemes and reports relating to Oxfordshire, Surrey, Bedfordshire, Lancashire, Birmingham, and Aberdeen; details regarding Scholarship schemes in the West Riding and Somerset; notes on the work of the counties and county boroughs; miscellanea; and reviews.

THERE are not many remains of the ancient Mexican feather-work which excited the surprise of the Spanish conquerors of the New World. The most famous surviving specimen is the standard, described by Hochstetter, which is now in the Vienna Ethnographical Museum. Another specimen has lately been discovered by Mrs. Zelia Nuttall in the Schloss Ambras, near Innsbruck. It is mentioned in an inventory, drawn up in 1596, of the treasures of the castle. This very valuable relic is the decorative part of a round shield made of interlaced reeds, and consists of feather-mosaics representing a monster, the contours of which are fastened by strips of gold. Formerly the shield was adorned with costly quetzal feathers, only small fragments of which survive. *Globus*, which has an interesting note on the subject, speaks of similar old Mexican shields in the Stuttgart Museum, and refers to a statement of Stoll to the effect that beautiful feather-ornaments are still made by the Indians of Guatemala.

IN the Report of the U. S. National Museum for 1884, Prof. O. T. Mason published a short paper on the throwing-sticks of the Eskimo. The use of a like device for the throwing of spears and harpoons was formerly well known in Mexico; and Prof. Mason has written to *Science* to say that he lately received from Lake Patzcuaro, in Mexico, "a modern altai, well worn and old-looking, accompanied with a gig for killing ducks." The apparatus, which was bought from the hunter by Captain J. G. Bourke, U. S. A., has been placed in the National Museum. The thrower is 2 feet 3 inches long, and has two finger-holes, projecting, one from the right, one from the left side. The gig consists of three iron bars, exactly like the Eskimo trident for water-fowl. "The problem now is," says Prof. Mason, "to connect Alaska with Patzcuaro."

A PAMPHLET on "The Dwarfs of Mount Atlas," by Mr. R. G. Haliburton, has been published by Mr. David Nutt. Along with it are printed portions of the paper on the subject read by Mr. Haliburton before the recent Oriental Congress. His views are accepted by Sir J. Drummond-Hay, who represented Great Britain in Morocco for over forty years, and by Mr. Hunnot, our Consul at Safi. There is, of course, no inherent improbability in the statement that there are tribes of dwarfs to the south of Mount Atlas. Such tribes are known to exist elsewhere in Africa, and they may exist in the regions where Mr. Haliburton thinks he has discovered them. The question is one of evidence. Even if dwarfs have many settlements there, it does not follow that there is any solid foundation for Mr. Haliburton's theories as to the part their race has played in the evolution of mythology. Still the suggestion is an interesting one.

IN the report on "Oysters and Oyster-Fisheries of Queensland," to which we referred last week, Mr. Saville-Kent presents quite an idyllic picture of the circumstances of those who devote themselves in Queensland to the culture of "bank oysters"—that is, oysters which spread over extensive level banks that are more or less uncovered at low water. He says that "probably in no other country in the world is so healthy, congenial, and unlaborious a means of earning a substantial competency open to, and turned to practical account by, all classes as that of bank oyster culture in the Queensland oyster-producing districts of Moreton or Wide Bays. With a nominal rental payable for the ground cultivated and occupied for a homestead, a climate that permits of dispensing with all but the most necessary form of raiment, and fish procurable in such abundance as to substantially minimize the butcher's bill, no more perfect terrestrial Elysium is probably at the disposal of small capitalists having sufficient means for the supply of their most immediate necessities during that first year or two that must elapse before their oyster-crops have increased to a remunerative extent."

MR. CHARLES CHILTON contributes to the new number of the *Records of the Australian Museum* (vol. i. No. 8) an excellent paper on a new and peculiar fresh-water "Isopod" from Mount Kosciusko. Towards the end of 1889, Mr. Chilton received from the trustees of the Australian Museum, Sydney, a small collection of Australian Crustacea, containing, among others, some terrestrial and fresh-water species collected by Mr. R. Helms while on an expedition to Mount Kosciusko on behalf of the Museum. Among these Mr. Chilton at once saw that one was quite different from any of the terrestrial and fresh-water Crustacea previously described from Australia, and that it belonged to a genus *Phreatoicus* established by himself in 1882, for a peculiar blind subterranean Isopod found in wells in Canterbury, New Zealand. This genus was of special interest, both because of the situation in which the original species was found, and because it combined characters belonging to several different families, and was also, to some extent, intermediate between the Isopoda and the Amphipoda. The discovery of a species belonging to the same genus in such a widely remote situation as Mount Kosciusko, and living under such different conditions, was therefore of peculiar interest; and Mr. Chilton thinks that it will probably have an important bearing on the difficult question of the origin of the blind subterranean forms. In the paper in the *Records* he does not enter upon this question, but he hopes to do so on a future occasion, when describing more fully the subterranean forms from New Zealand.

MESSRS. MACMILLAN AND Co. have issued the fifth edition, revised, of Part IV. of Prof. M. Foster's "Text-book of Physiology." This completes the work, with the exception of the appendix, which differs so widely in character from the rest of the book that it seemed desirable to issue it separately. It will be published very shortly.

SOME time ago the Department of Agriculture in New South Wales included in its list of economic plants suitable for cultivation in the north-eastern portion of the colony the "Avocado" or "Alligator pear" (*Persea gratissima*, Gaertn.). Several inquiries about it having since been made, Mr. F. Turner provides an account of the plant, with an illustration, in the August number of the *Agricultural Gazette* of New South Wales. Unless it is grown in very sheltered situations, the climate of Sydney is too cold for its successful cultivation as a commercial crop; but Mr. Turner thinks that on the northern rivers of New South Wales it should bear fruit as prolifically as it does in Southern Queensland. Some years ago, in the Brisbane Botanic Gardens, a fine Alligator pear-tree bore annual crops of very fine fruit, and it may do so still. When Sir W. W. Cairns was Governor of Queensland, he often asked Mr. Turner for some of the fruit when it was in

season, and Mr. Turner kept him well supplied, for at that time no one seemed to care much for it. His Excellency told Mr. Turner he was very fond of the fruit for breakfast, and he used to eat it spread on bread and butter, with pepper and salt added to give it zest, and in various other ways. Mr. Turner did not care for the fruit at first, but afterwards became as fond of it as his tutor. So we are not unlikely to hear of the Alligator pear by-and-by as a popular Australian product.

MESSRS. J. B. BAILLIÈRE ET FILS, Paris, have lately added some good volumes to their well-known Bibliothèque des Connaissances Utiles. In one of them—"La Pêche et les Poissons des Eaux Douces"—M. Arnold Locard presents a clear and interesting summary of the various classes of facts which must be understood by all who desire to become expert in the art of fishing in fresh waters. M. Lacroix-Daniard contributes a volume on "La Plume des Oiseaux," dealing with the birds whose feathers are utilized by man, and with the industrial processes to which the demand for feathers has given rise. A useful volume on "Les Plantes d'Appartement et les Plantes de Fenêtres" is contributed by M. D. Bois.

UNDER the title "Bibliotheca Accipitraria," Mr. J. E. Harting has on the eve of publication a bibliography of falconry, with critical notes. It deals with 378 works in various languages, ancient and modern, and will be illustrated with portraits of famous falconers by Holbein, Titian, Vandyck, Frans Floris, Gerhardt, and other masters. The volume concludes with an English glossary, and a vocabulary, in seven languages, of the technical terms used by falconers.

AN important treatise on Salt-Range fossils has been issued in the series entitled "Palæontologia Indica," which contains figures and descriptions of the organic remains procured during the progress of the Geological Survey of India. Prof. Waagen, the author of the treatise, in concluding it says he has tried to make it as useful as possible both to Indian geology and to geological science in general.

MR. STUART A. RUSSELL'S new work on electric light cables and the distribution of electricity will be issued shortly in Messrs. Whittaker's "Specialists' Series."

MESSRS. DULAU AND Co. have issued a catalogue of zoological and palæontological books which they offer for sale. It includes the following "parts"—Natural history publications of the British Museum; Protozoa, Bacteria; Cælestrata.

THE last volume of the Memoirs of the Statistical Section of the Russian Geographical Society contains an interesting work by M. Borkovsky, who has devoted more than twenty-five years of his life to the study of the grain-production of Russia, and the directions in which cereals are transported within Russia both for export and for home consumption. The results totally upset the current theory as to Russia being a granary of Europe, and are grimly confirmed by the famine which now prevails in several provinces of the empire. It appears from M. Borkovsky's figures and maps that Russia may be divided into two parts, strictly dependent on her orographical structure: one of them, which corresponds to the south-eastern slope of the broad swelling which stretches across the country from south-west to north-east, has an excess of grain during the years of good crops, which excess sometimes exceeds twice or thrice the wants for local use. But there is also another part—the north-western one—which always has less corn than is wanted for its population. Taking the years 1882-85, which were years of average crops, a line traced from Kieff to Nijni-Novgorod and further north-east divides Russia into two almost equal parts, of which the south-eastern exports wheat and rye into the north-western

part to the amount of no less than 710,000 tons of wheat and 508,000 tons of rye, the exports to foreign countries attaining at the same time the respective figures of 1,780,000 and 1,029,600 tons. Taking into account the respective populations of the two regions, and the amount of corn consumed by the distilleries (which does not exceed 14 English pounds per inhabitant), M. Borkovsky shows that the total consumption of wheat and rye attains only the figure of 437 pounds per inhabitant (109 pounds of wheat) in the exporting region, and the still lower figure of 382 pounds (46 pounds of wheat) in the region which imports corn. The average consumption throughout Russia thus attains only 430 pounds per inhabitant, out of which 14 pounds must be deducted for the use of the distilleries. These figures will certainly seem very low if it is remembered that the great mass of the Russian peasants consume extremely small quantities of meat—bread being their chief and almost exclusive food. It appears, moreover, that if Russia exported no grain at all, and the whole of the crop of cereals were consumed within the country, the average consumption would nearly approach the average consumption in France—that is, 505 English pounds on an average year; while the surplus obtained during years of exceptionally good crops would only cover the deficit during the bad years, which recur in the steppes of South-East Russia with almost the same regularity as in India, *i.e.* every ten to twelve years.

AN important paper is contributed by M. Moissan to the current number of the *Comptes rendus* describing two interesting new compounds containing boron, phosphorus, and iodine. A few months ago M. Moissan succeeded in preparing the iodide of boron (comp. NATURE, vol. xliii. p. 565), a beautiful substance of the composition  $BI_3$ , crystallizing from solution in carbon bisulphide in pearly tables, which melt at  $43^\circ$  to a liquid which boils undecomposed at  $210^\circ$ . When this substance is brought in contact with fused phosphorus an intense action occurs, the whole mass inflames with evolution of violet vapour of iodine. Red phosphorus also reacts with incandescence when heated in the vapour of boron iodide. The reaction may, however, be moderated by employing solutions of phosphorus and boron iodide in dry carbon bisulphide. The two solutions are mixed in a tube closed at one end, a little phosphorus being in excess, and the tube is then sealed. No external application of heat is necessary. At first the liquid is quite clear, but in a few minutes a brown solid substance commences to separate, and in three hours the reaction is complete. The substance is freed from carbon bisulphide in a current of carbon dioxide, the last traces being removed by means of the Sprengel pump. The compound thus obtained is a deep-red amorphous powder, readily capable of volatilization. It melts between  $190^\circ$  and  $200^\circ$ . When heated *in vacuo* it commences to volatilize about  $170^\circ$ , and the vapour condenses in the cooler portion of the tube in beautiful red crystals. Analyses of these crystals agree perfectly with the formula  $BPI_2$ . Boron phospho-di-iodide is a very hygroscopic substance, moisture rapidly decomposing it. In contact with a large excess of water, yellow phosphorus is deposited, and hydriodic, boric, and phosphorous acids formed in the solution. A small quantity of phosphoretted hydrogen also escapes. If a small quantity of water is used a larger deposit of yellow phosphorus is formed, together with a considerable quantity of phosphonium iodide. Strong nitric acid oxidizes boron phospho-di-iodide with incandescence. Dilute nitric acid oxidizes it to phosphoric and boric acids. It burns spontaneously in chlorine, forming boron chloride, chloride of iodine, and pentachloride of phosphorus. When slightly warmed in oxygen it inflames, the combustion being rendered very beautiful by the fumes of boric and phosphoric anhydrides and the violet vapours of iodine. Heated in contact with sulphuretted hydrogen, it forms sulphides of boron and phosphorus and hydriodic acid, without liberation

of iodine. Metallic magnesium when slightly warmed reacts with it with incandescence. When thrown into vapour of mercury, boron phospho-di-iodide instantly takes fire.

The second phospho-iodide of boron obtained by M. Moissan is represented by the formula  $BPI$ . It is formed when sodium or magnesium in a fine state of division is allowed to act upon a solution of the di-iodide just described in carbon bisulphide; or when boron phospho-di-iodide is heated to  $160^\circ$  in a current of hydrogen. It is obtained in the form of a bright-red powder, somewhat hygroscopic. It volatilizes *in vacuo* without fusion at a temperature about  $210^\circ$ , and the vapour condenses in the cooler portion of the tube in beautiful orange-coloured crystals. When heated to low redness it decomposes into free iodine and phosphide of boron,  $BP$ . Nitric acid reacts energetically with it, but without incandescence, and a certain amount of iodine is liberated. Sulphuric acid decomposes it upon warming, with formation of sulphurous and boric acids and free iodine. By the continued action of dry hydrogen upon the heated compound the iodine and a portion of the phosphorus are removed, and a new phosphide of boron, of the composition  $B_2P_3$ , is obtained.

The additions to the Zoological Society's Gardens during the past week include a Macaque Monkey (*Macacus cynomolgus* ♂) from India, presented by Mr. James Hammond; two Pink-footed Geese (*Anser brachyrhynchus*), British, presented by Mr. Cecil Smith, F.Z.S.; two Tuberculated Tortoises (*Homopus femoralis*) from South Africa, presented by the Rev. G. H. R. Fisk, C.M.Z.S.; two White-tailed Sea-Eagles (*Haliaeetus albicilla*), European, purchased.

#### OUR ASTRONOMICAL COLUMN.

THEORY OF ASTRONOMICAL ABERRATION.—An interesting point connected with astronomical aberration was raised by M. Mascart in a paper presented to the Paris Academy of Sciences on November 2. It would at first appear that if observations demonstrated that the constant of aberration had precisely the same value for all stars, the velocity of light in space must be uniform. This interpretation, however, seems open to objections. Eclipses of Jupiter's satellites furnish a method for determining the velocity of light in the space contained within the earth's orbit, and, as is well known, the results obtained in this manner agree very well with those deduced from experiments made on the surface of the earth. But astronomical aberration depends only upon the relation of the velocity of the observer to that of the light in the region occupied by the instrument, and is unaffected by any variations in the velocity of propagation of the light-waves between the object observed and the earth. A real difference in the constant of aberration given by different stars would therefore indicate that the velocity of light was not uniform in the parts of space traversed by the earth. From this reasoning, M. Mascart is led to conclude that the values derived from the experiments, direct and astronomical, made to determine the velocity of light, should be limited to the space contained within the terrestrial orbit. The induction is certainly a legitimate one, and it must be admitted that to consider the velocity of light in interstellar space as uniform is to rely entirely on hypothesis.

#### SUGGESTIONS FOR SECURING GREATER UNIFORMITY OF NOMENCLATURE IN BIOLOGY.<sup>1</sup>

COMPLAINTS are constantly being made, not only by laymen but by actual workers in science, of the increasing complexity of modern terminology. The fact is indisputable, but is it altogether to be regretted? Is it not rather the outward expression of fuller knowledge and clearer conceptions? If so,

the complaints of those indolent persons who wish to gain a "general knowledge" of the subject with the least possible trouble to themselves are worthy of no more consideration than those of the landsman out yachting, of whom Mr. Hamerton writes:—

"You cannot speak of anything on board without employing technical terms which, however necessary, however unavoidable, will seem to him a foolish and useless affectation by which an amateur tries to give himself nautical airs. If you say 'the main-sheet,' he thinks you might have said more rationally and concisely, 'the cord by which you pull towards you that long pole which is under the biggest of the sails,' and if you say 'the starboard quarter,' he thinks you ought to have said, in simple English, 'that part of the vessel's side that is towards the back end of it and to your right hand when you are standing with your face looking forwards.'"

As a modern yacht or ironclad requires a more elaborate terminology than a fishing-boat or a trirème, so it is necessary that the exact morphology of to-day—to speak only of one branch of biology—should be weighted with a more extensive nomenclature than was required for the simpler comparative anatomy of former days. That many are repelled by the bristling outwork of more or less barbarous Greek and Latin compounds is undoubted, and is much to be regretted; but I quite fail to see that it can be avoided as long as we have to deal with a comparatively inflexible language like English. I would recommend anyone who is deeply impressed with the evils of the present system to try and translate a technical description of one of the ordinary students' types—say an earthworm or a crayfish—into "plain English" without loss of conciseness or lucidity.

I think it may be taken as axiomatic that whenever the bounds of knowledge are extended, either by the investigation of new problems or by the re-examination of old ones with the aid of improved methods and extended views, an elaboration of nomenclature is inevitable. Indeed, the introduction of an extended terminology, either because of the discovery of new facts or of the more accurate grouping of old ones, is a distinct gain; it emphasizes an actual advance in knowledge.

There are, however, certain undoubted evils connected with the introduction of new terms which must have troubled all of us at some time or other.

Two workers at a given subject living in different parts of the world invent each a terminology of his own. Each system is adopted by the inventor's own friends or countrymen, and no attempt is made by the general body of biologists to give either scheme official sanction—on grounds of priority or otherwise. In this respect systematists have a great advantage; if a given specific or generic name can be shown to have priority, it takes precedence of every other, however much more suitable the latter may be. Morphological names, on the other hand, always run the risk of being either ignored altogether, or ousted by others which, although no more appropriate, and perhaps considerably later in date, happen to be invented or adopted by some widely-read author.

New terms are sometimes proposed without a due sense of responsibility—on inadequate grounds or even from mere love of novelty; and, on the other hand, the conservative tendency leads to the continued employment of unsuitable terms when appropriate ones have been proposed in their place. New names are often casually introduced in the body of a large and highly technical paper, where they are certain to be seen by few; and, lastly, it frequently happens that such terms are inadequately defined.

Unfortunately this state of things can hardly be remedied by anything corresponding to the British Association's Rules, which have proved so useful in systematic zoology and botany. In these departments the appropriateness of a name is a matter of little importance, but in morphological nomenclature suitability is of far more importance than priority, and the most respectable and time-honoured terminology should never be allowed to stand in the way of one by which homologies, mutual relations, &c., are adequately expressed.

As morphology is essentially a progressive science, any attempt to draw up hard and fast rules on nomenclature is for the most part to be deprecated; the fittest must be allowed to survive. I think, however, that a few rules and definitions might be framed and afforded the official sanction, say, of the British, American, and Australasian Associations.

For instance, it is about time that we made up our minds as to what exactly we mean by *biology*, whether the whole science

<sup>1</sup> A Paper read before Section D (Biology) of the Australasian Association for the Advancement of Science, Christchurch, N.Z., by T. Jeffery Parker, B.Sc., F.R.S., Professor of Biology in the University of Otago, January 1891.

of living things, or that department which deals with the mode of life of organisms—habits, relation to the environment, &c.; the former use of the term is almost universal in English-speaking countries, but many of the leading German writers give it the other signification. Again, *morphology* and *anatomy* are terms of fundamental importance, and zoologists and botanists might surely agree upon a common definition for each. The same applies to other terms common to the two sub-sciences, *ovary* being the most flagrant example of divergence. To take one more example, the word *biogenesis* was introduced by Prof. Huxley to signify the origin of organisms from pre-existing organisms. Eimer, in his recent work on organic evolution, uses the term *biogenetic law* for the law that individual recapitulates ancestral development.

Another matter, which might certainly be settled once for all, is the meaning to be attached to adjectives and prefixes denoting position, such as dorsal and ventral, anterior and posterior, proximal and distal, mesial and lateral, epi-, hypo-, pre-, post-, &c. Such terms of position, although easy enough to apply in most cases, are constantly being misused; *epipubis* (for *pre-pubis*) is a modern and widely-used term; the dorsal and ventral roots of the spinal nerves are still frequently called *anterior* and *posterior*, and the great body-veins the *superior* and *inferior* venæ cavae; and the botanical use of many terms of position (e.g. the *dorsal* and *ventral* sutures of a carpel) is absolutely meaningless.

Another step in the right direction would be the publication, under the auspices of the British, American, and Australasian Associations, the Anatomische Gesellschaft, and similar bodies, of a glossary of biological terms, in which the history of the word, its inventor, the precise sense in which he used it, and any subsequent changes of meaning it may have undergone, would be set forth. Such a glossary might, I think, be usefully arranged under somewhat similar headings to those employed in the *Zoologischer Jahresbericht*, the whole work being of course supplied with an alphabetical index. With a single responsible editor, and a sub-editor for each department, the work would not be one of insuperable difficulty.

An even more practicable suggestion than the last, and one which, although supplementary to, is not dependent upon it, is that in such publications as the *Zoological Record*, the Journal of the Royal Microscopical Society, and the *Zoologischer Jahresbericht*, there should be a record of new terms as well as of new species. The recorders who do the work of these publications with such fidelity and success, would hardly find their labours increased by noting down all the new terms used by the authors in their various departments, and placing them in a special list, each being accompanied by name of author, date, and definition. If this were done, we should have fewer instances both of useless synonyms and of identical words being employed for totally distinct things. I do not think, for instance, that the body-cavity of Peripatus would have been called a *pseudocæle* by Mr. Sedgwick, or a *metacæle* by Mr. Hatchett Jackson, if these writers had had the means of knowing that the former term had been previously applied by Dr. Burt Wilder to the so-called fifth ventricle of the mammalian brain, and the latter to the fourth ventricle.

Finally, matters would be very much improved if every author who finds himself obliged to coin a word would notify the fact in a conspicuous part of his paper, accompanying the term with an adequate definition. One has only to point to Hallen's monograph on the Gynoblastic Hydroids, or to Alcock's Report on the Deep-Sea Medusæ, to give a practical instance of the advantage of such a practice.

My proposals for promoting greater uniformity of nomenclature in biology may therefore be summed up under three heads, as follows:—

1. The appointment of a strong international committee to define terms of general and fundamental importance, such as the subdivisions of biological science, terms common to zoology and botany, terms denoting position, &c.
2. The issue of an authoritative historical glossary.
3. The systematic record of new terms.

### METEORIC IRON.

THE *Annalen des k.k. naturh. Hofmuseums*, No. 2 of vol. vi., contains a further contribution by E. Cohen and E. Weinschenk to their interesting studies on meteoric irons.

By treating comparatively large masses in the cold with very

dilute hydrochloric acid (1 in 20) so that the process of solution was very slow, in some cases extending to several months, a residue is left from which it is found possible to isolate several more or less definite compounds, distinct from the freely soluble main mass of the meteorite.

It is in the portion insoluble in the highly dilute acid, which in some cases amounts to no more than 5 per cent. of the whole, that the main interest in analytical work on meteoric irons centres. The patience and care involved in the separation of its various constituents often find their reward in some interesting discovery. As a typical example of the constituents into which a meteorite may be separated by this treatment with dilute acid, it will suffice to quote the percentage numbers obtained in the case of a slice of the Magura iron. They are as follows:—

Nickel-iron which passed into solution	92·67 per cent.
Cohenite	... .. 4·00 "
Tænite + jagged fragments	... .. 0·13 "
Schreibersite	... .. 0·09 "
Tænite + cohenite	... .. 2·93 "
Non-magnetic residue	... .. 0·18 "

In most meteoric irons the soluble portion consists to a large extent of a nickel-iron kamacite, which mainly constitutes the broad layers of the Widmanstätten figures seen on an etched polished surface. The authors are of opinion, from a comparison of various analyses, that this alloy has a constant composition represented by the formula  $Fe_{11}Ni$ .

Cohenite, which occurs in very brittle tin-white crystals, has at present been only found in the Magura iron. It was analyzed and described in a previous paper by Dr. Weinschenk, who found it to consist of a definite carbide of iron, nickel, and cobalt, having the composition represented by the formula  $(FeNiCo)_3C$ . Very similar crystals in the Wichita iron were found to have the composition represented by the formula  $(FeNiCo)_3C$ , analogous to the well-known spiegeleisen,  $Fe_3C$ . Cohenite corresponds to the carbide  $Fe_3C$ , which separates out in crystals when cast-iron is slowly cooled between 600° and 700°. Many points of resemblance such as this between meteoric and ordinary cast-iron appear to show that the conditions as regards temperature, &c., during their production must have been very similar in the two cases.

Tænite, occurring usually in thin silver-white lamellæ of great toughness between the broader layers of kamacite, is a nickel-iron, of which there appear to be two varieties, containing respectively about 65 and 73 per cent. of iron. Further analyses, however, are necessary in order to determine its true composition. The jagged and angular fragments of iron-black colour were analyzed, and found to consist of a nickel-iron containing about 7 per cent. of nickel, and were thus in all probability identical with kamacite.

The phosphor-nickel-iron schreibersite is generally found in large tabular crystals of tin-white colour. The new analyses show that its composition may be represented by the formula  $(FeNiCo)_3P$ . In some meteorites a phosphor-nickel-iron occurring in needles is found. This is the so-called rhadbitte of Rose. Whether it is identical or not with schreibersite has not yet been decided, owing to the difficulty of obtaining pure material. A non-magnetic residue, consisting chiefly of transparent grains, the authors find is common in greater or less amount to most meteoric irons. In such residues a great variety of minerals have been identified with more or less certainty, such as diamond, cliftonite (a graphitic pseudomorph after diamond), quartz, tridymite, chromite, cordierite, garnet, corundum, pyroxenes both rhombic and monoclinic, &c.

The aim of the authors in the present investigation was to answer the following questions:—How widely distributed is cohenite? Are schreibersite and rhadbitte definite compounds? Has kamacite a constant composition? Has tænite always the same physical and chemical properties? What is the composition of the jagged fragments? So generally left undissolved after treatment of meteoric irons with dilute hydrochloric acid? How widely distributed are the transparent grains, as well as the diamond, cliftonite, &c.?

Unfortunately, owing to the fact that the present joint investigation had to be brought to a somewhat premature conclusion, a definite answer to all of these questions could not be given. We may, however, expect soon to hear more on the points still left undecided, as the promise is made that the gaps in the present investigation shall be filled up as soon as possible.

G. T. P.

### UNIVERSITY AND EDUCATIONAL INTELLIGENCE.

OXFORD.—The first election to a Geographical Studentship will be held at the end of Hilary Term 1892. The student at the time of his election must have passed all the examinations for his B.A. degree in the University of Oxford, but must not be of more than eight years' standing from matriculation. Previous to his election he must have attended the lectures of the Reader in Geography in at least two terms. Information as to the conditions of tenure may be obtained from the Reader in Geography.

The Report of the Delegacy of Non-Collegiate Students was presented to Convocation on Wednesday. It shows that the list of matriculations is rather larger than in the preceding year, but the total number of undergraduates has somewhat decreased. The total number on the books (440) is the largest which has yet been reached. Thirty-six took the B.A. degree, and nineteen the M.A. during the year. The Delegates notify that they admit, without examination, students in any special branch of study who do not desire to pass through the Arts course, and can show evidence of fitness for their special subject. Sixteen students have availed themselves of this privilege during the year. The balance-sheet appended shows that the financial condition is satisfactory. The total receipts exceeded the expenditure by £550, and the accumulated balance in the hands of the Delegacy at the close of the year was £2284.

CAMBRIDGE.—Mr. J. Macalister Dodds, of Peterhouse, has been elected Chairman of the Examiners for the Mathematical Tripos, Part I.

A petition from 2689 persons residing in New Zealand has been received by the Vice-Chancellor, praying that the Senate will grant degrees to properly qualified women. The signatories include Sir George Grey, K.C.B., formerly Governor of New Zealand, most of the Ministers of the Colonial Government, and many professors and graduates of the University of New Zealand.

Lord Wal-ingham, F.R.S., High Steward of the University, offers annually a gold medal to B.A.'s of not more than two years' standing for the best monograph or essay giving evidence of original research on any botanical, geological, or zoological subject; zoology being understood to include animal morphology and physiology, and an essay on any subject of chemical physiology being valued according to its physiological rather than its chemical importance.

MR. R. W. STEWART, B.Sc. (Lond.), has been appointed Assistant Lecturer and Demonstrator in Physics at the University College of North Wales, Bangor.

### SCIENTIFIC SERIALS.

THE *American Meteorological Journal* for October contains:—A short memoir of the late Prof. W. Ferrel, by Prof. A. McAdie, with a complete list of his scientific contributions, from 1853 to 1891; his last paper, which appeared in our columns in April 1891, was entitled "The High-pressure Area of November 1889 in Central Europe."—The mineral waters of Ypsilanti and other places in Michigan, by Dr. E. N. Brainerd.—Cloud observations at sea, by Prof. C. Abbe. This is a preliminary report relative to the principal features of the work done by him during the recent cruise of the *Pensacola* to the West Coast of Africa. A number of experiments were made to determine the relative speed and direction of movement of the various strata of air, by means of clouds and small balloons. The experiments showed that the use of balloons is practicable both on sea and land, and gives accurate results. The following are some of the results of the author's observations: the vertical circulation increases and the horizontal circulation diminishes in the doldrums; the horizontal movement is a maximum at high latitudes; the bases of the cumuli are lower and their tops higher in the low latitudes; if there be any general east wind in the upper regions at the doldrum it is above the clouds, and therefore not observable.—The last article is by Dr. Leudet, on the action of climates at elevated stations on diseases of the chest.

*Bulletin de l'Académie des Sciences de St. Pétersbourg*, new series, vol. ii., No. 1.—On the scales of *Holoptychius* found in Russia, by Dr. Rohon (French). The histology of the same is

described, as also two new species: *Hol. virius* and *Hol. superbus*.—Ichthyological notes from the Museum of the Academy, by S. Herzenstein, being a description of the following new species: *Coltus vivosus*, *Centridermichthys alricornis*, *Hypogonus gradiens*, *Sticheus grigorievi*, *St. dictyogrammus*, *Chilophilus japonicus*, *Pleuronectes obscurus*, *Pl. japonicus*, *Pl. bicoloratus* (incompletely described by Basilewsky), *Hippoglossus grigorievi*, *Alburnus charusini*, and *Nemachilus kuschakewitschi*.—On the extraordinary phenomena presented by the great comet of 1882, by Th. Bredichin. After having given in a preceding paper his reasons for considering the interior tube of that comet as an anomalous tail, the author applies the same explanation to the exterior tube.—On two new laws of celestial mechanics, by H. Struve. In addition to the previously communicated results of observations made on the satellites of Saturn with the 30-inch refractor, Prof. Struve points out the remarkable relations which exist between the satellites Mimas and Tethys on the one side, and Enceladus and Dione on the other side. The observations of Mimas have shown that its orbit has an inclination of 1° 26' on the equator of Saturn, and that its nodes have a motion of 1° every day, so that by the end of the year the orbit returns to its previous position; moreover, a considerable acceleration has been noticed in the rotation of Mimas during the last few years. From these facts M. Struve deduces the following law:—"Four times the average movement of Tethys, minus twice the average movement of Mimas, is always equal to the sums of the average movements of the nodes of the orbits of Mimas and Tethys on the equator of the planet." The same law may also be expressed in this way:—" (1) The conjunctions of Mimas and Tethys always take place about a point which is situated halfway between the ascending nodes of their orbits on the equator of Saturn. They may move off this point for about 48", and this libration is performed in sixty-eight years. (2) The conjunctions of Enceladus and Dione always coincide with the perisaturn of Enceladus, or, at least, they must oscillate around this point." Several important conclusions relative to the mass of Rhea and that of the rings may be deduced from these laws.—On the genus *Obolus* (Eichwald), by A. Mickwitz.—On a personal equation in photometric observations of stars, by E. Lindemann.—The mammals of the Gan-su expedition of 1884-87, by Eug. Büchner (German). The few species of this very interesting fauna which have been brought to St. Petersburg, are described, the remainder being kept in the Museum of Irkutsk.—On the rotation of Jupiter, by A. Belopolsky (in German). From a perusal of all available data, the author finds the rotation-period to be equal to 9h. 55m. in the latitudes from 10° to 45°, while in the zone 0° to 5°, it is only 9h. 50m.—On the Ammonites of the Artinsk strata, by A. Karpinsky (German). The collection is derived from North-East Russia; the new species are: *Prorotites postcarbonicus*, *Pr. prepermicus*, *Parapronotites tenuis*, *Gastrioceras suessi*, *Agathiceras uralicum*, *Popanoceras krasnopolskyi*, and *Thalassoceras gemmellari*.—On a new process for separating iron-oxide from aluminium, by F. Beilstein and R. Lüther.—Chemical notes, by N. Beketoff.—On the use of incandescent light for self-registering instruments, by H. Wild.—On artificial amphibolite, by K. Khruščoff.

In the *Botanical Gazette* for September and October, Mr. T. Holm continues his series of articles on the minute comparative anatomy of American grasses. Brief abstracts are given of the botanical papers read at the Washington meeting of the American Association for the Advancement of Science, and at that of the Botanical Club of the same Association. Other papers are chiefly of interest to American botanists.

### SOCIETIES AND ACADEMIES.

LONDON.

Zoological Society, November 3.—Prof. W. H. Flower, F.R.S., President, in the chair.—The Secretary read a report on the additions that had been made to the Society's Menagerie during the months of June, July, August, and September, 1891, and called attention to certain interesting accessions which had been received during that period.—The following objects were exhibited:—(1) On behalf of Mr. F. E. Blaauw, a stuffed specimen of a young Wondrous Grass-Finch (*Poephila mirabilis*), bred in captivity at his house in Holland; in the behalf of Prof. E. C. Stirling, a water-colour drawing of the new



Australian Mammal *Notoryctes typhlops*; (3) by Mr. G. A. Boulenger, an Iguana with the tail reproduced; (4) by Mr. R. Gordon Wickham, a very fine pair of horns of the Gemsbok (*Oryx gazella*) from Port Elizabeth, South Africa; and (5) by Dr. Edward Hamilton, a photograph of an example of the Siberian Crane (*Grus leucogeranus*), shot on the i-land of Barra, Outer Hebrides, in August last.—Mr. R. Lydekker gave a description of some Pleistocene Bird-remains from the Sardinian and Corsican Islands. These belonged mostly to recent forms, but to genera and species which in several instances had not been found fossil. They showed rather more of an African character than the present avifauna of these islands.—Mr. R. Lydekker also read some notes on the remains of a large Stork from the Allier Miocene. These remains were referred to the genus, closely allied to *Ciconia*, lately named *Pelargopsis*, but which (that term being preoccupied) it was now proposed to rename *Pelargoides*.—Mr. R. Lydekker also exhibited and made remarks on the leg-bones of an extinct Dinornithine Bird from New Zealand, upon which he proposed to base a new species allied to *Pachyornis elephantopus* (Owen), and to call it, after the owner of the specimens, *Pachyornis rothschildi*.—Dr. A. Günther, F.R.S., read a description of a remarkable new Fish from Mauritius belonging to the genus *Scorpaena*, which he proposed to call *Scorpaena frondosa*.—A communication was read from Mr. Roland Trimen, containing an account of the occurrence of a specimen of the scarce Fish *Lophotes cepedianus*, Giorna, at the Cape of Good Hope.—A communication was read from the Hon. L. W. Rothschild, giving a description of a little-known species of *Papilio* from the Island of Lifu, Loyalty Group.—Mr. R. J. Lechmere Guppy read some remarks on a fine specimen of *Pleurrotomaria* from the island of Tobago.—A communication was read from Mr. L. Péringuey, giving an account of a series of Beetles collected in Tropical South-western Africa by Mr. A. W. Eriksson.

**Entomological Society, November 4.**—Dr. D. Sharp, F.R.S., Vice-President, in the chair.—Mr. W. F. Kirby exhibited a series of a very dark-coloured form of *Apis* reared by Mr. John Hewitt, of Sheffield, from bees imported from Tunis, and which he proposed to call "Punic bees."—Mr. C. G. Barrett exhibited five melanic specimens of *Aplecia nebulosa*, reared from larvae collected in Delamere Forest, Cheshire, and described in the Proceedings of the Lancashire and Cheshire Natural History Society as *A. nebulosa*, var. *Rossoni*. Mr. Barrett also exhibited a beautiful variety of *Argynnis aglaia*, taken in Norfolk by Dr. F. D. Wheeler, and two specimens of *Lycena argiades*, taken in August 1885, on Bloxworth Heath, Dorsetshire.—Mr. H. St. John Donisthorpe exhibited a collection of Coleoptera, comprising about thirty-six species, made in a London granary in 1890 and 1891. The genera represented included *Sphodrus*, *Calathus*, *Quectius*, *Crepilidius*, *Omalium*, *Frogosita*, *Silvanus*, *Lathridium*, *Dermestes*, *Anthrenus*, *Ptinus*, *Niptus*, *Anobium*, *Blaps*, *Tenebrio*, *Calandaria*, and *Bruchus*.—Mr. A. B. Farn exhibited a series of specimens of *Eubolia lineolata*, bred from a specimen taken at Yarmouth. The series included several remarkable and beautiful varieties, and the size of the specimens was much above the average.—The Rev. Dr. Walker exhibited specimens of *Argynnis ino* and *A. pales*, from Norway.—Mr. B. A. Bower exhibited, for Mr. J. Gardner, specimens of *Nephropteryx splendens*, H. S., *Botys lupulinatis*, Ck., and *Bryotropha obscurella*, Hein., taken at Harlepool.—Mr. R. Adkin exhibited two very dark specimens of *Peronea cristana*, from the New Forest.—Colonel C. Swinhoe exhibited, and remarked on, types of genera and species of moths belonging to the *Tineina*, all of which had been described by Walker, and placed by him amongst the *Lithoside*.—Mr. H. Goss exhibited specimens of *Callimorpha hera*, taken by Major-General Carden in South Devon in August last, and observed that the species appeared to be getting commoner in this country, as General Carden had caught seventeen specimens in five days. Mr. Goss said that the object of the exhibition was to ascertain the opinion of the meeting as to the manner in which this species had been introduced into this country. A discussion on the geographical distribution of the species ensued, in which Mr. G. T. Baker, Colonel Swinhoe, Mr. McLachlan, Mr. Verrall, Captain Elwes, Mr. Barrett, Mr. Fenn, and others took part.—Mr. C. J. Gahan contributed a paper entitled "On South American Species of *Diabrotica*," Part III.—Mr. McLachlan contributed a paper entitled "Descriptions of New Species of Holophthalmous *Ascalaphidae*."—Mr. W. L. Distant communicated a paper entitled "Descriptions of Four New Species of

the Genus *Fulgora*."—Mr. F. Enock read a paper entitled "Additional Notes and Observations on the Life-history of *Alypus picus*." Every detail in the life-history of this spider was most elaborately illustrated by a large number of photographs, made by Mr. Enock from his original drawings, and shown by means of the oxy-hydrogen lantern. A discussion followed, in which Mr. C. O. Waterhouse, Dr. Sharp, Mr. G. C. Champion, the Rev. A. E. Eaton, and Mr. P. Crowley took part.

**Anthropological Institute, November 10.**—Dr. Edward B. Tylor, F.R.S., President, in the chair.—Mr. Francis Galton exhibited, on behalf of Lady Brooke, a photograph of a human figure carved on a rounded sandstone rock in Sarawak; the rock is about twelve feet in height, and the sculpture is in high relief and of the size of life. Mr. Galton also exhibited some imprints of the hand, by Dr. Forgeot, of the Laboratoire Criminale, Lyon.—Dr. Tylor read a paper on the limits of savage religion. In defining the religious systems of the lower races, so as to place them correctly in the history of culture, careful examination is necessary to separate the genuine developments of native theology from the effects of intercourse with civilized foreigners. Especially through missionary influence since 1500, ideas of dualistic and monotheistic deities, and of moral government of the world, have been implanted on native polytheism in various parts of the globe. For instance, as has lately become clear by the inquiries of anthropologists, the world-famous Great Spirit of the North American Indians arose from the teachings of the Jesuit missionaries in Canada early in the seventeenth century. This and analogous names for a Supreme Deity, unknown previously to native belief, have since spread over North America, amalgamating with native doctrines and ceremonial rites into highly interesting but perplexing combinations. The mistaken attribution to barbaric races of theological beliefs really belonging to the cultured world, as well as the development among these races of new religious formations under cultured influence, are due to several causes, which it is the object of this paper to examine: (1) direct adoption from foreign teachers; (2) the exaggeration of genuine native deities of a lower order into a God or Devil; (3) the conversion of native words, denoting a whole class of minor spiritual beings, such as ghosts or demons, into individual names, alleged to be those of a Supreme Good Deity or a rival Evil Deity. Detailed criticism of the names and descriptions of such beings in accounts of the religions of native tribes of America and Australasia was adduced, giving in many cases direct proof of the beliefs in question being borrowed or developed under foreign influence, and thus strengthening the writer's view that they, and ideas related to them, form no original part of the religion of the lower races. The problems involved are, however, of great difficulty, the only hope of their full solution in many cases lying in the researches of anthropologists and philologists minutely acquainted with the culture and languages of the districts; while such researches will require to be carried out without delay, before important evidence, still available, has disappeared.

## PARIS.

**Academy of Sciences, November 9.**—M. Duchartre in the chair.—On the use of chronophotography for the study of machines constructed for aerial locomotion, by M. Marey. It is known that, in the case of a plane moving in a fluid medium, the centre of pressure only coincides with the centre of figure if the plane be normal to the direction of its motion; but if the plane makes an angle with its trajectory, the centre of pressure occurs in advance of the centre of figure to an extent which increases as the plane forms a more acute angle with the direction of motion, and as its velocity of translation is increased. This principle is strikingly illustrated by some photographs of a specially constructed falling body taken at intervals of a twentieth of a second. The body first described a sensibly parabolic curve, it then rose slightly, and passed over a convex curve before reaching the ground. The figure accompanying the paper shows clearly that the inflexions of the body's trajectory depend on the variations of its velocity, and the inclination of its surface with respect to the direction of motion.—On the laws of the intensity of light emitted by phosphorescent bodies, by M. Henri Becquerel. The author develops formulæ to represent the relation between the intensities of light emitted by phosphorescent bodies and the duration of illumination, and compares the results of some of

his father's observations with those obtained by calculation. The agreement of the two sets of numbers is very close, even when the intensity was taken some thirty minutes after the body had been emitting light. A relation is also established between the intensity and the time that the body was exposed to light.—Study of boron phospho-iodides, by M. Henri Moissan. (See Notes, p. 67.)—M. Haton de la Goupillière made some remarks on the paper read by Sir William Thomson before the Royal Society, on April 9, "On Electrostatic Screening by Gratings, &c.," saying that he had published some similar results in 1859.—Experimental determination of the velocity of propagation of electro-magnetic waves, by M. R. Blondlot. Experiments have been made between wave-lengths 8'94 and 35'36 metres, and the results show that all electrical undulations have a velocity of propagation of about 297,600 kilometres per second.—On algebraic integrals of the differential equation of the first order, by M. Autonne.—On surfaces with rational generators, by M. Lelievre.—Theory of turbo-machines, by M. Rateau.—A simple method of verifying the centres of the object-glasses of microscopes, by M. C. J. A. Leroy.—On the existence of acid or basic salts of monobasic acids in very dilute solutions, by M. Daniel Berthelot. The author has studied very dilute solutions near the point of neutralization, using HCl and baryta water at a concentration of 0'01 equivalent per litre, by the method of measuring the electric conductivities. He concludes that acid and basic salts are not destroyed by dilution, even very dilute solutions containing traces undecomposed.—On the formation of hydrates at high temperatures, by M. G. Rousseau.—On a double chloride of copper and lithium, by M. A. Chassevaut. A substance of the composition  $2\{CuCl_2 \cdot LiCl\} + 5H_2O$  has been obtained. It is decomposed by water, but is soluble to a red-brown solution in a concentrated solution of lithium chloride from which it may be recrystallized.—Researches on digitaline, by M. J. Houdas.—On isochinones, by MM. E. Jungfleisch and E. Leger.—Estimation of fats in milk products, by MM. Lezé and Allard.—Ptomaines extracted from urine in cases of some infectious maladies, by M. A. B. Griffiths. The ptomaine from scarlet fever has the composition  $C_{12}H_{12}NO_4$ , that from diphtheria  $C_{14}H_{17}NO_6$ ; they have also been prepared from pure cultures on peptonized gelatine of *Micrococcus scarlatine* and *Bacillus diphtherie* respectively. The ptomaine from the urine of a case of mumps has the constitution  $NH : C(NH_2) \cdot N(C_2H_5)_2 \cdot CH_2 \cdot CO_2H$ . None of the three ptomaines described are constituents of normal urine.—On the exterior form of the muscles of man with respect to the movements executed (experiments made by chronophotography), by M. G. Demyen.—On the formation of the peripheral nervous system of vertebrates, by M. P. Mitrophanow.—On the effects of parasitism on *Ustilago antherarum*, by M. Paul Vuillemin.—Meteorological observations made at Rodez, by M. des Vallières.

## AMSTERDAM.

Royal Academy of Sciences, October 31.—Prof. van de Sande Bakhuizen in the chair.—Prof. P. H. Schoute offered some general remarks on Lemoine's two problems of stamps: In how many different ways a ribbon of  $p$  stamps and a rectangular sheet of  $pq$  stamps can be folded up in one? (compare vol. i. p. 120 of the "Théorie des Nombres" of E. Lucas). He reduced the first problem to a question in the theory of permutations, gave the number  $x_p$  of its solutions up to  $p = q$ , and showed why the number  $x_{pq}$  of the solutions of the second problem must

surpass the expression  $\binom{p+q-2}{p-1} x_p x_q$ .—Prof. B. J. Stokvis made a contribution to our knowledge of mutual antagonism and the combined action of mutual antagonists. In experimenting on the isolated and freely pulsating frog's heart, he stated that digitaline on the one side, and muscarine (or chinine) on the other, were to be considered as mutual antagonists for this organ, and displayed their antagonistic action, whichever of the two might be applied first. In another series of experiments he studied the action of muscarine and digitaline flowing at the same time with the nourishing blood through the isolated frog's heart, and found that the greatest antagonistic action, for instance of digitaline, was displayed when very dilute solutions (1 : 25,000 or 1 : 33,333) were applied at the same time as moderately strong solutions of muscarine. Finally, he stated that the isolated frog's heart recovered much faster and much more easily by normal blood when it was previously poisoned by muscarine and digitaline combined than when it was poisoned

by the same or even a lower dose of muscarine alone.—MM. S. Hoogewerf and W. A. van Dorp gave an account of the action of an aqueous solution of ammonia on phthalic chloride. If care is taken to keep the liquids cool in mixing, about 40 per cent. of the weight of the chloride is converted into orthocyanobenzoic acid,  $C_6H_4 \begin{matrix} CN \\ COOH \end{matrix}$ .

## BOOKS, PAMPHLETS, and SERIALS RECEIVED.

BOOKS.—The Land of the Lamas, W. W. Rockhill (Longmans).—Arphimixis; oder Die Vermischung der Individuen: A. Weismann (Jena, Fischer).—Primitive Culture; 2 vols., 3rd edition, revised: Dr. E. B. Tylor (Murray).—Mémoires of the Geological Survey of India, vol. xxiii. Geology of the Central Himalayas: J. L. Griesbach (Calcutta).—L'Homme dans la Nature: P. Topinard (Paris, Alcan).—Outlines of Physiological Chemistry, 2nd edition: F. C. Larkin and R. Leigh (Lewis).—My Personal Experiences in Equatorial Africa: T. H. Parke (Low).—An Introduction to the Theory of Value: W. S. Smart (Macmillan).—Quantitative Chemical Analysis: F. Clowes and J. B. Coleman (Churchill).—A Hand-book of Industrial Organic Chemistry: S. P. Sadler (Lippincott).—Farm Crops: J. Wrightson (Cassell).—Our Common Birds and how to Know Them: J. B. Grant (Gay and Bird).—The Microscope and its Relations, 7th edition: Dr. W. H. Dallinger (Churchill).—How to Use the Aneroid Barometer: E. Whymper (Murray).—Beobachtung an der Russischen Polar-station auf Nowaja Semlja, 2 Theil: Magnetische Beobachtungen: K. Andrejef (St. Petersburg).—Selected Essays of Arthur Schopenhauer: E. B. Baz (Bell).—About Ceylon and Borneo: W. J. Clutterbuck (Longmans).—With Axe and Rope in the New Zealand Alps: G. E. Manninger (Longmans).—The Microscope and Histology, Part 1, The Microscope and Microscopical Methods: S. H. Page (Ithaca, N. Y.).—Anthropogenie-oder Entwickelungsgeschichte des Menschen, 2 vols.: E. Haeckel (Leipzig, Engelmann).

PAMPHLET.—A Memoir on the Coefficients of Numbers: B. Seal (Calcutta).

SERIALS.—Bacteriological World, vol. i. No. 10 (Battle Creek, Mich.).—Proceedings of the Aristotelian Society, vol. i. No. 4, Part 2 (Williams and Norgate).—Himmel und Erde, November (Berlin, Paetel).—Bulletin de l'Académie Impériale des Sciences de St. Pétersbourg, nouvelle série ii. (xxxiv.) (St. Pétersbourg).—Harvard University Bulletin, No. 50.

## CONTENTS.

PAGE

Scotch Fisheries . . . . .	49
The Mammals of India. By W. H. F. . . . .	50
A Text-book of Chemical Physiology and Pathology. By Dr. E. H. Starling . . . . .	51
Our Book Shelf:—	
Vogel: "Praktisches Taschenbuch der Photographie" . . . . .	51
Miller: "An Introduction to the Differential and Integral Calculus" . . . . .	52
Gore: "Star Groups."—G. . . . .	52
"The Universal Atlas."—G. . . . .	52
Gulbenkian: "La Transcaucasie et la Péninsule d'Apchéron" . . . . .	52
Suffling: "How to Organize a Cruise on the Broads" . . . . .	52
Letters to the Editor:—	
A Difficulty in Weismannism.—Edward B. Poulton, F.R.S. . . . .	52
Town Fogs and their Effects.—M. . . . .	53
The Eclipse of the Moon.—Robert C. Leslie . . . . .	53
Comparative Palatability.—E. B. Titchener . . . . .	53
The Inheritance of Acquired Characters.—Alfred W. Bennett . . . . .	53
"The Darwinian Society."—William White . . . . .	53
Some Notes on the Frankfort International Electrical Exhibition. V. (Illustrated.) By W. E. A. . . . .	54
The Implications of Science. I. By Dr. St. George Mivart, F.R.S. . . . .	60
Electricity in Relation to Science. By Prof. William Crookes, F.R.S . . . . .	63
Geological Photographs . . . . .	64
Notes . . . . .	64
Our Astronomical Column:—	
Theory of Astronomical Aberration . . . . .	68
Suggestions for securing Greater Uniformity of Nomenclature in Biology. By Prof. T. Jeffery Parker, F.R.S . . . . .	68
Meteoritic Iron. By G. T. P. . . . .	69
University and Educational Intelligence . . . . .	70
Scientific Serials . . . . .	70
Societies and Academies . . . . .	70
Books, Pamphlets, and Serials Received . . . . .	72

THURSDAY, NOVEMBER 26, 1891.

## ELECTRO-MAGNETISM.

*The Electro-magnet and Electro-magnetic Mechanism.*

By S. P. Thompson, D.Sc., F.R.S. (London: E. and F. N. Spon, 1891.)

THIS is a reprint, with additions, of a course of Cantor Lectures which the author delivered during 1890 before the Society of Arts. The book, it may be stated at the outset, is an excellent account of electro-magnetic mechanism, and abounds in information at once of historical, scientific, and practical value. Evidently the author is willing to spare no pains to give completeness to any work of this kind he undertakes, and the present book, like his treatise on dynamo-electric machinery, will no doubt be widely read and appreciated.

In the preface, and elsewhere in the body of the book itself, Dr. Thompson indulges in some statements which we think are a blemish on an excellent and well-written treatise. It serves no good purpose to distribute in a scientific book praise or blame to certain classes of scientific investigators, and while glorifying a certain section of workers, to pour what seems little short of contempt and derision on the labours of another. We refer here to the statements (chiefly in the preface) regarding the earlier mathematical theories of magnetism, and their alleged influence in retarding electro-magnetic discovery.

It is quite true that some of the older theorists, concentrating their attention on the magnetic field of a system of permanent magnets, gave only a secondary attention to the problem of the internal constitution of a magnet. But it is hardly fair to put down against them, by inference, the errors of the persons who persisted in assuming that, because it had been proved that a magnet produces a field which can also be accounted for by a distribution of imaginary magnetic matter over the surface of the magnet, the magnetization of the magnet did consist in such a distribution. Such an equivalent distribution is a conception helpful in itself, inasmuch as it can be experimentally determined, and expresses exactly the manner in which the lines (unit tubes) of magnetic induction leave the surface. But to accuse it of misleading those who misunderstood it, is to put on the shoulders of Gauss and others who considered surface distributions a responsibility which is not theirs, and a blame which properly belongs to the perverse experimentalists who have insisted on determining the actual positions of "poles" in bar magnets, and on measuring other things equally indeterminate or non-existent.

But is the following statement quite free from possibility of misconstruction? "Gradually, however, new light dawned. It became customary, in spite of the mathematicians, to regard the magnetism of a magnet as something that traverses or circulates around a definite path, flowing more freely through such substances as iron than through other relatively non-magnetic materials." If any student of the subject does get into his head the idea that an actual material something flows round a magnetic circuit, he might quite as justly hold Dr. Thompson responsible for this false notion as blame the mathe-

maticians for causing him to suppose a magnet to be a body plastered over with imaginary magnetic matter.

In tracing the evolution of the notion of magnetic permeability, Dr. Thompson might have made some mention of the contributions to molecular theory given by Poisson and others; for after all, these men really knew as well as we do "that magnetism, so far from residing in the end or surface of the magnet, is a property resident throughout the mass." But, as has already been stated, their attention was chiefly directed to the fields of permanent magnets; and to find a doctrine which "will afford a basis of calculation such as is required by the electrical engineer" is the business of the electrical engineer himself, and others interested in the problem. Hitherto, indeed, so far as such a doctrine has been found, it has been discovered in great measure by the physical mathematician! The mathematical doctrine of "magnetic permeability," or—to use Faraday's phrase—"conductivity for magnetic lines of force," was given so long ago as 1872 by Sir William Thomson, and fully illustrated by analogies and applications; and it is certainly curious that so accurate an historian as Dr. Thompson should, in his historical *résumé*, have made no mention of this very important paper. It is also the fact that our knowledge of the properties of iron, which, with the "simple law of the magnetic circuit," constitutes, according to Dr. Thompson, the stock-in-trade of the designers of dynamos, has come in no small degree from the same source. The most eminent investigator and improver of the dynamo is also a mathematician; but perhaps, as Sir William Hamilton (of Edinburgh, not of Dublin!) said of a certain mathematician who, he was forced to admit, reasoned correctly, he did it in spite of his mathematics, not because of them.

All honour to the great mathematicians who first attacked the difficult subject of magnetic action. But even if they had sinned so grievously by their impracticality as it seems now the fashion to try to make out, their successors, entering into their labours, have been able to do much to atone by helping the engineer in the difficulties which beset his advance into a region, viewed indeed from afar, but hitherto untrodden. In this great work the engineer and mathematician are necessarily companions, and for either to reproach the other, as to what happened or did not happen in the past, is only to provoke useless recrimination, and delay their onward progress.

It is time now to come to the subject-matter proper of the book, and for this we have, on the whole, nothing but commendation. There are some things which might, perhaps, have been expressed differently with advantage, but this, of course, is only a matter of opinion. In the first chapter a very interesting account is given of the inventions and researches carried out by Sturgeon, Henry, and Joule, and ends with a description of notable electro-magnets. The sketch of Sturgeon's career, given in an appendix to this chapter, is of remarkable interest as a plain unvarnished record of heroic toil in the pursuit of knowledge, carried on amid uncongenial surroundings, and in spite of the hard pinch of poverty. In happier circumstances, this experimental genius would no doubt have done much for science. Still, to us there is some compensation, for, had it not

been for the *res angusta domi* of his later years, we might not have had his "Annals of Electricity" or his "Scientific Researches." As it is, it seems well established that he was the pioneer of electro-magnetic discovery, the maker of the first electro-magnet and the first magneto-electric machine; and Dr. Thompson has done a simple act of justice in bringing Sturgeon's claims in this respect before the great public now interested in the progress of electrical science.

In chapter ii. we have generalities concerning electro-magnets and electro-magnetism, descriptions of typical forms of electro-magnets, and materials of construction. First are discussed such topics as the uses of electro-magnets, magnetic polarity, magnetic units, and elementary propositions in electro-magnetism. Here we would remark, as a merit in this work, the fact that the author has not loaded what is intended to be a thoroughly practical treatise with long discussions of purely theoretical matters, however important in relation to practice. The sketches of theory given in many works—which are really only collections of tables of numerical data, lists of formulæ, and workshop recipes—would be much better left out, and their places supplied by other matter, or the books lightened by their absence.

An excellent chapter follows, on the properties of iron. The various methods of measuring permeability are well explained, and for the space devoted to it a good account (with tables) is given of the results obtained by Hopkinson and Ewing in their researches. On p. 108 the effect of opening gaps in a magnetic circuit of iron is discussed, and a reference is given to an experiment described later in the work. On turning to this experiment (p. 212), it is found to be a description of an exploration of the effect produced at different parts of a horseshoe steel magnet by pulling off the keeper. A narrow coil of a few turns of wire is wound on a light frame capable of being slid round the magnet, and is connected with a ballistic galvanometer. The effect of pulling off the keeper is then tested with the coil in different positions on the horseshoe, and is shown by the deflection of the needle of the ballistic galvanometer. The theory of the author is, that putting on or taking off the keeper of a permanent steel magnet does not affect the magnetization at the middle of the horseshoe; that by putting on the keeper, and so diminishing the magnetic "reluctance" of the circuit, the lines of magnetic force are only collected, not altered in amount. Hence, if this theory be true, the coil, when placed at the middle of the magnet, should show no effect on the removal of the keeper. It is stated that careful and repeated experiments made at Finsbury gave an effect at the middle of the magnet which did not amount to  $1/3000$  of that found when the coil was close up to either end of the magnet.

Some time ago, when informed by a friend of this statement and result, the writer, feeling extremely doubtful of their general truth, had a magnet constructed for the purpose of repeating the experiments. As a large magnet was required for other purposes, one was constructed of eight steel bars of a mean length of about 3 feet. Each bar was 2 inches broad by  $\frac{1}{4}$  inch thick, so that when put together they formed a large horseshoe of square cross-section 2 inches in side. A keeper, made of a block of soft iron, fitted between the ends of the horseshoe. The

steel, which was tool steel obtained from a local firm, took magnetism readily, and an excellent horseshoe magnet was obtained.

A coil in circuit with a ballistic galvanometer was used in the manner described above, to test the effect of removing the keeper. Careful experiments made by students, and repeated by the writer, gave an entirely different result from that obtained by Prof. Thompson. A very large throw was obtained by placing the coil close to either end of the magnet and detaching the keeper; but with the coil as nearly as possible at the middle of the horseshoe, the throw was about *one-eighth* of the maximum. It was verified, moreover, that the minimum throw was obtained at the middle.

This result was exactly what the writer had expected would in general happen. The so-called free magnetism at the extremities of the magnet, in the absence of the keeper, produced a demagnetizing effect throughout the magnet, and thus diminished the induction through the coil, even when at the middle. This action was counteracted by the magnetizing effect of the keeper when in position, and therefore itself inductively magnetized, but had full play as soon as the keeper was removed. The much greater deflections near the ends were undoubtedly due to the cause to which Dr. Thompson would assign the whole effect—the alterations of the arrangement of the lines near the ends which accompanied the removal and replacement of the keeper.

It is certain that this effect will depend on the permeability of the magnet steel, which is a function of the magnetization; but that such an effect will in general be produced there does not seem to be any room for doubt.

The following chapters deal with specially designed electro-magnets, such as, for example, those used in relays and clockwork, electro-magnetic mechanism, alternate-current electro-magnets, electro-magnetic motors and machine tools, and the purely electro-magnetic part of the book winds up with a very interesting chapter on the electro-magnet in surgery. The last chapter of all is devoted to permanent magnets. To give a satisfactory account of these chapters is here impossible; but it may be mentioned that the electro-magnetic mechanism fully described and figured includes no less than nine classes, beginning with the different forms of magnet with moving armature or plunger, magnets with armatures moving against counterpoises of different kinds, polarized devices, electro-magnetic vibrators, magnetic brakes, &c.

In chapter xi., on alternate-current electro-magnets, the modes of laminating magnets for the prevention of eddy-currents are described; then follows a discussion of effects of alternating electro-magnets, depending on the difference of the phase relations of the magnets and the eddy-currents excited in conductors in the form of disks and rings placed near the extremities of the iron cores. Thus we have a very interesting account of Elihu Thomson's remarkable experiments. The throttling or impedance effect of electro-magnets included in circuits is next treated. It would have been worth noticing, were the relations of maximum current, maximum electromotive force, mean current, mean electromotive force, and impedance are given, that the true mean value of the total electrical activity in an alternating circuit, in which

work is done against resistance only, as in lighting glow-lamps, is equal to the mean square of the current multiplied by the total resistance in circuit.

In the chapter on the electro-magnet in surgery, Dr. Thompson, as was to be expected, gives a careful summary of the history of the subject. It seems that hitherto the principal use has been in ophthalmic surgery, for the extraction of small particles of iron from the eyeball. A very interesting case is narrated, in which the author's brother, Dr. Tatham Thompson, of Cardiff, successfully removed, by a magnetic probe constructed according to his own design, a fragment of iron which had passed through the eye of a blacksmith and lodged in the retina. The probe, excited by a coil, was inserted through the vitreous humour of the eye along the track of the wound, and catching the bit of steel, drew it from its resting-place in the retina. With the exception of a slight limitation of the field of vision, the patient perfectly recovered his sight.

The writer has a lively remembrance of being present some years ago at a search made, by means of a magnetic probe which he had arranged for one of the surgeons of Glasgow Infirmary, for a fragment of iron which was alleged to have entered the knee of a blacksmith. The blacksmith was exceedingly lame, and an examination of the knee by means of a magnetometer for signs of the presence of iron had resulted in some very puzzling indications. All iron, it was thought, had been removed from the patient, and with the knee in certain positions very decided indications of magnetized iron or steel had been observed. The probe, magnetized by a battery current, was inserted in an incision made at the place where the iron was supposed to have entered, but without effect. An adhesion was found to exist in the joint, and was broken down by the surgeon, with the result that after the patient's recovery the lameness had disappeared. It was found on stripping the patient that he wore a truss, and hence the magnetometer effects!

It seemed rather unlikely, in any case, that the magnetic probe would be effective in removing a splinter deeply embedded in muscular tissue.

The last chapter, on permanent magnets, though no part of the subject-matter proper of the book, is nevertheless very complete, and full of valuable information regarding the magnetizability of different kinds of steel, effects of temperature, use of laminated magnets, lifting power of magnets, and permanence of magnets with lapse of time.

The chapter concludes with a short sketch of astatic arrangements of needles. In connection with these, it may be remarked that the vertical pair of astatic needles—which has the advantage of perfect and permanent astaticism, inasmuch as each needle is astatic—was described, with other astatic arrangements, in a paper by Mr. T. Gray and the present writer, in the Proceedings of the Royal Society for 1884 (vol. xxxvi).

Here we must take leave of a most interesting volume. The outside of the book is tastefully got up, the printing and paper are excellent, and the whole is worthy of the reputation of both author and publishers.

A. GRAY.

#### FUNGUS EATING.

*British Edible Fungi: how to Distinguish and how to Cook them.* By M. C. Cooke. (London: Kegan Paul, Trench, Trübner, and Co., 1891.)

There is a fascination in the minds of many people for the eating of fungi, which has often been expressed in popular books on the subject by authors of various degrees of power. Some of these are enthusiasts, who suffer palpably from that malady of intolerance which characterizes so many propagandists, who would persuade us that those things are best to eat and drink which they have found so; others, again, temper their recommendations by the calm arguments of the scientific man, though, speaking as having found, they must write with a tinge of that persuasiveness necessary to overcome wide-spread prejudice, or ignorance, if they are to be understood by the multitude; others, again, are content to state the facts, and let the logic of their sentences make its own impression in due course.

It is not easy to say off-hand in which of these categories the writer of the book under review should be classed, nor is it of much consequence to look at his writings according to the decision arrived at in that connection. It is certainly no more than fair to say that Mr. Cooke has compiled a little book of no small value as a guide to common edible fungi of this country; and that, while the information is singularly clear, and told in plain and homely language, it loses little or nothing in the simple telling, so far as the facts about these cryptogams are concerned. In so far, the author's well-known reputation as a mycologist is not likely to suffer; but it must be added that, while we do not pretend to criticize in detail all that relates to the cooking of these delicacies, and while it must always be more or less a matter of individual opinion whether *Chanpignons* stewed with pepper and butter, or *Boletus* with sauce of lemon-juice and powdered lump-sugar, are the more delicious, there is something that smacks of prejudice in the more than hearty commendation of some of the cooked favourites. Be this as it may, Mr. Cooke is unquestionably a high authority on his subject, and he has done good service in supplying the public with a well-written account of it, and with excellent coloured drawings of about forty of the chief forms of edible fungi.

Few people in this country are aware that nearly two hundred of the things called toadstools are at least edible, and fewer still will be prepared to believe that there are people in the world who regard some fifty-odd of these as dainties. Mushrooms, truffles, and morels exhaust the list for most Englishmen, and many are dubious about even these, and eat them, when served, with various degrees of trustful confidence, or the reverse.

It is a severe shock to these persons when they learn that such species as *Amanita rubescens*, *Leptota procerus*, *Coprinus comatus*, and other "horrid toadstools," may not only be eaten, but are even extolled as delicious; and when it comes to recommending the green-topped *Clitocybe odorus*, smelling of anise, or the purple *Tricholoma nudus*, and other violently coloured species, the amateur may be pardoned for hesitating. Nevertheless, these and many other forms popularly held as dangerous are not only edible, but are also capable of distinction with a

little practice. It may, perhaps, be doubted whether specialists do not commonly underrate the difficulties in diagnosis of these forms to an amateur, but Mr. Cooke can at least be felicitated on having made the distinguishing characters as clear as popular language admits.

In addition to the chapters on edible fungi, there is an interesting one on poisonous species, which may convince the reader of error in supposing that these are so numerous as is vulgarly supposed. The fact is, we know very little about the poisonous forms. Some few are thoroughly established as poisonous, and great care should be exercised by amateurs in view of this fact; but by far the majority of toadstools are simply not known to be edible. The following paragraph, from p. 208, may be worth quoting:—

“Over and over again have we been urged to lay down some rules, or instructions, whereby poisonous may be distinguished from innocuous fungi. As often have we declared, as we do now, that such general instructions are impossible. No rules can be given whereby a poisonous can be distinguished from a harmless species, nothing except knowledge and experience. The poisonous species already known are known because they have a past history which has condemned them, and not from any evidence written upon them. The most experienced mycologist cannot tell by any character, feature, or behaviour, that this or that fungus is poisonous or the reverse. He only knows its antecedents and the company it keeps. A large order of flowering plants, such as the *Solanaceae*, may be looked upon with suspicion; but the potato and tomato are not poisons. In the *Agarics* the sub-genus *Amanita*, with warted caps, have always been regarded with suspicion because of *Agaricus muscarius* and *Agaricus phalloides*; but two others of the same group, *Agaricus rubescens* and *Agaricus strobiliformis*, are most excellent food.”

This, in spite of traces of obscurity, may be taken as sound talk, showing an appreciation of the position by the author, who is, moreover, quite alive to what generalizations can be made as to the dangerous character of pink-spored genera, and the bright red forms of *Agaricus* and *Russula*, and so on; and we recommend this chapter of warnings to all who are inclined to taste rashly.

The printing of the text and illustrations is decidedly good, and we regard this little work as a gain to the popular naturalist's library.

#### “EXTENSION” PSYCHOLOGY.

*Psychology: a Short Account of the Human Mind.*

By F. S. Granger, M.A. (London: Messrs. Methuen and Co., 1891.)

THIS little volume, which forms one of Messrs. Methuen's “University Extension Series,” is not a mere compilation from larger works on psychology. Short as it is, it presents an independent development of the subject; and it is not infrequently characterized by a freshness and vigour most helpful to the student. We feel sure that Mr. Granger's short account of the human mind will be a most useful little book in the “psychology circles” of that National Home-Reading Union to the existence and work of which Dr. Hill drew attention in a recent issue of NATURE. And few subjects are better suited than psychology for study in this way.

NO. 1152, VOL. 45]

Mr. Granger lays great stress on the essential unity of the wave of consciousness that in its onward course constitutes our mental life. By introspection (which is also retrospection) we may analyze the waves that have passed; we may find elements of cognition, of feeling, and of will; we may separate out dominant and sub-dominant ideas, sensations from without the body and from within. But in the wave as it passes all these are fused into one state of consciousness from which no one of the constituent elements could be omitted without destroying its identity. Students are only too apt to fancy that the elements reached by psychological analysis have a reality more real than the state of consciousness with which they started. Mr. Granger does his best to help them to avoid this fallacy.

Welcome as the little book is from its independence of treatment, it shows signs of hurried composition. Apart from bits of sheer carelessness—e.g. where Mr. Granger speaks of “the facts with which we have to deal in”—the statements are occasionally ambiguous or misleading. “The retina, for example, may be supposed to transform all sorts of stimuli into sight impressions.” That is not well put. “The causes which give rise to states of mind may be divided into states of mind and states of body. Thus the sensation of red is due to a light-stimulus received from some object by way of the eye. Here, a state of mind, the sensation of red, is caused by a state of body—namely, a change in the retina. All cases of this kind, in which a mental effect follows upon a physical cause, are instances of physical laws. On the other hand, states of mind are very often due to previous states of mind,” &c. This, again, is awkward and misleading. The physical basis of a “sensation of red” is found in certain molecular changes in the brain; and these may be induced by changes in the retina (external origin), or by other changes in surrounding parts of the brain (internal origin). So far as the molecular changes which are the basis of the “sensation of red” are concerned, whether they be due to causes external to the brain or to causes within the brain, they are alike “instances of physical laws.” Here, and elsewhere in the book, the fundamental distinction between energy and consciousness, between the physical and the psychological, is not brought out with sufficient clearness.

In his preface, Mr. Granger tells us that “the illustrations are largely drawn from every-day experiences and familiar books.” If the following illustration correctly represents Mr. Granger's every-day experiences, Nottingham must be a somewhat dangerous place to live in. “A group of ideas may come into the mind, and by the process of association may bring up an idea of some movement or series of movements which is forthwith realized. The sight of a stranger leads to the idea, and then to the act, of throwing half a brick at him.” Even if the experience is of every-day occurrence, it can hardly be regarded as a happy illustration. C. LL. M.

#### OUR BOOK SHELF.

*Arithmetical Exercises in Chemistry.* By Leonard Dobbin, Ph.D. With Preface by Prof. Crum Brown. (Edinburgh: James Thin, 1891.)

THIS book is a short collection of problems dealing with chemical changes, and such physical changes as are

of special importance to junior students of chemistry. Examples are given on the metric system, thermometric scales, specific gravity, the gaseous laws, the weights and volumes of materials entering into chemical reactions, and on the calculation of the empirical formulae and percentage composition of compounds. As distinguished from others on the same subject, the book contains no more than the beginner requires, and is therefore less apt to confuse than one more elaborate. The introductory part of each section, giving the principles involved in the exercises, is clear, and the examples, 128 in all, seem well chosen. A table of contents, index, and answers, are included. A few points in connection with specific gravity might with profit be attended to. On p. 6, density, in reality absolute density, is defined, and then specific gravity. Relative density, as it is referred to on p. 31, might here be introduced, and the account would be more complete if the relation between density and specific gravity were clearly stated. After the formula  $s = w/v$ , on p. 9, it might be definitely pointed out that, with the units chosen, specific gravity is the weight of unit volume. It is not quite accurate to lead the student, as on p. 8, to infer that specific gravities are usually given for the temperature of 4° C.

*The Colliery Manager's Hand-book.* A Comprehensive Treatise on the Laying-out and Working of Collieries, designed as a Book of Reference for Colliery Managers, and for the use of Coal-mining Students preparing for First-class Certificates. By Caleb Pameley. Pp. 552, Index, and 472 Woodcuts. (London: Crosby Lockwood and Son, 1891.)

No doubt colliery managers, and students preparing for examinations, would find it convenient to have a cyclopædia of mining, but the hand-book under consideration will scarcely satisfy their wants. The work is another illustration of the proverb, "Ne sutor ultra crepidam." Instead of being satisfied with describing mining processes and mining plant, the author deliberately plunges into geology and chemistry, and then finds himself quite out of his depth.

It is evident that much labour has been expended in bringing together information upon various matters connected with coal-mining; but there are gaps which require to be filled up, and errors that should be corrected in a second edition. For instance, the chapter upon boring is meagre. The part relating to percussive boring is in the main borrowed from Greenwell, and refers solely to boring by hand. Not a word is said about free-falling tools. It is not correct to say that "a great advantage of the diamond-drill boring is that the hole is kept true and vertical." The surveys made with the ingenious "clinograph" of Macegeorge have shown beyond a doubt that this is not invariably the case.

The description of tools is insufficient; and strange to say, the book contains no figure of a pick. Probably no work on mining was ever written before without a figure of this characteristic miner's implement. It is not for want of space, because there are figures to illustrate the manner of preparing oxygen and nitrous oxide. These are really unnecessary: if the student wants to learn a little elementary chemistry, he had better have recourse to one of the numerous text-books on that subject.

The examples of the different methods of working coal are likely to confuse students, owing to the mass of details by which they are accompanied. As the original articles are available in the Transactions of the Mining Institute of Scotland, short abstracts would have been quite sufficient.

Serious omissions are somewhat numerous. Rittinger pumps, which are doing such excellent work on the Continent, are not mentioned; and the following important subjects are also entirely ignored: coal-washing, coking,

utilization of the gases for making tar and ammonia, and manufacture of patent fuel. In these days, when warning notes are being sounded concerning the duration of our coal supply, the attention of mining engineers and students should be specially directed to methods of turning small coal and inferior seams to profitable account. The author of a hand-book ought to be in advance of the times, and point out the path of economy and progress.

In spite of its defects, Mr. Pameley's work is by no means destitute of value. It contains a great deal of information which managers and students will find of use to them, and the excellent index will enable them to lay their hands at once on any part they desire to consult.

C. L. N. F.

*Photography applied to the Microscope.* By F. W. Mills. (London: Iliffe and Son, 1891.)

THE subject of photo-micrography is one of such absorbing interest that it is no wonder it has become so popular among amateurs. For those commencing, and for those who have already made some steps in pursuing this subject, the present little book is intended, and it will be found to contain just that sort of information and advice that is so necessary to a beginner. The main point to insure good photographic results lies in the preparation of the object, which requires both patience and care; the chapter dealing on this has been written by Mr. Charters White, who gives good directions for cutting hard and soft tissues, and for bringing materials, that are too soft in their natural condition, to a state of firmness previous to cutting. With regard to the choice of the necessary apparatus, the author describes various forms that are cheap, and which with care can be made to yield fair results. In the remaining chapters all the photographic manipulations are dealt with, such as exposing, developing, and printing, &c., and at the end is added a useful list of works which treat of the subject under consideration.

*Copernic et la Découverte du Système du Monde.* By Camille Flammarion. (Paris: Marpon and Flammarion, 1891.)

AN interesting book is this, and one full of information. In ten chapters and 250 pages M. Flammarion traces the history of astronomy from Copernicus to Newton, with special reference to the life of the former and the development of his system. There is little doubt that this work will be as well received as others by the same writer, and it really deserves the favour.

G.

*Annals of British Geology, 1890.* By J. F. Blake. (London: Dulau and Co., 1891.)

It is intended that this shall be the first issue of an annual publication; and, if future volumes are prepared with as much care as the present one, the work ought to be of much service to geologists. Its scope is restricted to writings which have appeared in the United Kingdom. The author is not content with noting merely the titles of the works he records. When they are of the least importance, he gives a general idea of their contents, and presents what seems to him an adequate critical estimate of their value. The classification is by subjects. He begins with general geology; then come stratigraphical geology, palæontology, palæobotany, petrology, economics, maps and sections, and works relating to foreign geology, but published in Britain. A section headed "Personal Items" brings together a number of facts to which it may sometimes be convenient for the student of geology to refer. The volume deserves to be all the more cordially welcomed because Mr. Blake is not of opinion that he has at one stroke reached perfection. He hopes that future volumes may be improved by the co-operation of specialists in the several departments.

## LETTERS TO THE EDITOR.

[The Editor does not hold himself responsible for opinions expressed by his correspondents. Neither can he undertake to return, or to correspond with the writers of, rejected manuscripts intended for this or any other part of NATURE. No notice is taken of anonymous communications.]

## Warning Colours.

In the experiments on "Comparative Palatability," recorded in NATURE of November 19 (p. 53), Mr. E. B. Titchener refers to the unpalatability of the brimstone butterfly. The insect was "fairly seized several times," but "was always rejected," by a frog. Some of your readers may not be aware that Mr. F. Gowland Hopkins, of Guy's Hospital, has recently shown that the yellow pigment of this butterfly, and of several others of its allies, is due to a substance formed as a urinary pigment; it is also known that the colours of other butterflies, and other animals, bear a relation to the urinary pigments. These substances may be in many cases of a disagreeable flavour. Dr. Eisig, of the Naples Zoological Station, has suggested that if intense and varied coloration is primarily due to a great quantity and variety of such bitter-tasting pigments, we do not need to assume that the brilliant coloration has been brought about in order to advertise the nauseous taste. The bright and varied colour will be, in fact, a consequence of the deposition in the integument of bitter pigments. This view—which has for the most part escaped the attention of those who have written upon animal colours, owing doubtless to its having been put forward in a special monograph upon a group of worms (*Capitellidae*)—better explains how it is that brightly-coloured unpalatable creatures are in so many (?) the majority of) cases tasted before being refused. I have laid some stress upon this view of warning coloration in a forthcoming book upon "Animal Coloration," which is to be published by Messrs. Swan Sonnenschein and Co. FRANK E. BEDDARD.  
Zoological Society's Gardens, Regent's Park.

## The Salts in Natural Waters.

The communication of Mr. Lyons, in NATURE of November 12 (vol. xlv. p. 30), giving an analysis of the water of the salt lake of Aalia Paakai, affords a suitable opportunity for asking a question, to which, I trust, some chemist among the readers of NATURE will be able to give a satisfactory answer.

The usual analysis of the "solid constituents" of a given specimen of natural water only directly determines, I believe, the respective quantities of the metallic bases—sodium, calcium, &c.—and of the non-metallic constituents—chlorine, carbonic acid, &c.—contained in the "total solids." How does the chemist, then, proceed to mate these two classes of constituents together, so as to be able to state with confidence what salts, and in what quantities, are held in solution in the water? The problem itself would appear to be an indeterminate one, at any rate if there are more than two of either class of constituents. What additional considerations are introduced to render the problem determinate? Are they definite chemical conditions; or is there more or less arbitrariness in the assumptions made, so that two chemists would not necessarily arrive at the same result?

In the case of the Honolulu lake, there are, according to Mr. Lyons's analysis, three non-metallic constituents (*chlorine, bromine, sulphuric acid*)—(is not the absence of carbonic acid remarkable?)—and four metals (*sodium, potassium, calcium, magnesium*); the quantities of which have, I suppose, been obtained by direct analysis. From the twelve possible combinations of these constituents to form simple salts, five have been excluded, the sulphates of sodium and potassium, and the bromides of these metals and calcium also, thus reducing the number to seven, the quantities of which can, of course, be definitely determined from the seven direct data of the analysis. Is it certain, however, on assured chemical grounds, that none of these excluded salts are contained in the water, and if not, on what principle has their possible existence been ignored?

I write, as is evident, with but very slight knowledge of chemical analysis; and possibly answers to my questions are to be found in some text-book. If so, I should be obliged by a reference to any easily accessible work in which the question is discussed.

K. B. H.

## Mental Arithmetic.

The following method of multiplying large numbers together mentally, if new, may interest some of your readers. If it has been published before, I should be glad to learn where it may be found. The process is so simple that, though I have no special gift for mental arithmetic, I was able, almost without practice, to multiply together correctly seven figures by seven, and to write down the result from left to right.

Suppose it is desired to multiply 123 by 456. The sum is usually written thus:—

$$\begin{array}{r} 123 \\ 456 \\ \hline 738 \\ 615 \\ 492 \\ \hline 56088 \end{array}$$

If, instead of completing each step in the multiplication as we arrive at it, and carrying the tens to the left, the digits are merely connected by the multiplication sign and written down in their proper places, the result is:—

$$\begin{array}{r} 1 \quad 2 \quad 3 \\ 4 \quad 5 \quad 6 \\ \hline 1 \times 6 \quad 2 \times 6 \quad 3 \times 6 \\ 2 \times 5 \quad 3 \times 5 \\ 3 \times 4 \\ \hline 1 \times 4 \quad 1 \times 5 \quad 2 \times 4 \\ 2 \times 4 \end{array}$$

$$1 \times 4 \quad (1 \times 5 + 2 \times 4) \quad (1 \times 6 + 2 \times 5 + 3 \times 4) \quad (2 \times 6 + 3 \times 5) \quad 3 \times 6$$

If the figures in the lowest line are multiplied out and the tens carried to the left in the usual way, the result is, of course, the same as that given by the ordinary procedure. Thus, to obtain the first figure, beginning at the right, we say: " $3 \times 6 = 18$ —8 and carry 1." To obtain the second figure: " $2 \times 6 = 12$ ;  $3 \times 5 = 15$ ;  $12 + 15 + 1$  (which has been carried) =  $28$ —8 and carry 2." And so on. Thus each figure of the answer can be obtained by multiplying together certain digits of the multiplier and multiplicand, and adding the amount to be carried from the calculation of the previous figure, without the strain of remembering all the horizontal rows of results and their relative positions vertically. It remains only to show which digits of the multiplier and multiplicand must be combined. A consideration of the example worked out above will show that, to obtain the first figure of the answer, we multiply the 1st digit (from the right) of the multiplier (6) by the 1st of the multiplicand (3). To obtain the second, we multiply the 1st of the multiplier by the 2nd of the multiplicand and the 2nd of the multiplier by the 1st of the multiplicand (*i.e.* the first two of each line) crosswise, and add the products. Similarly, the third figure is obtained by multiplying the first three digits of each line crosswise, *i.e.* 1st by 3rd, 2nd by 2nd, and 3rd by 1st, and adding the products. The number of digits employed in the process is now at a maximum, and begins to diminish. To obtain the fourth figure, we multiply together crosswise all the digits except the first of each line, *i.e.* the group  $\begin{matrix} 12 \\ 45 \end{matrix}$ . And to obtain the last figure, we multiply all except the first two of each line, *i.e.* the group  $\begin{matrix} 1 \\ 4 \end{matrix}$ .

If the number of digits in the multiplier is less than that in the multiplicand, the procedure is the same till all the digits of the multiplier are used in the combination. For each successive figure, the group of digits in the multiplicand to be used shifts along one place to the left till it comes to the end. The group then diminishes as before, by dropping the right-hand digit in each line. For example: the groups, the digits of which are multiplied together crosswise, in multiplying 123456 by 789, are as follows:—

Digits—	8th.	7th.	6th.	5th.	4th.	3rd.	2nd.	1st.
1	12	123	234	345	456	567	678	789
7	78	789	789	789	789	789	89	9

It will be found, on trial, that this method is quite easy, and can be accomplished by anyone who can add together in his head the products of two digits, and can remember the string of figures which form the answer. This is most easily done by



repeating the whole series from left to right, as each successive figure is arrived at.

The power of multiplying as many as seven figures by seven is not likely to be of much practical value, and when carried to this stage the method is merely a curiosity; but it may be of use in helping us to multiply together small amounts, consisting of two or three digits, which lie beyond the scope of the multiplication table.

I will conclude with a short example, showing what passes through the mind in working the method.

Multiply 987 by 654.

987  
654

First figure.— $4 \times 7 = 28$ . Eight and carry two. 8  
 Answer (so far) ... .. 8  
 Second figure.— $4 \times 8 = 32 + 2$  (carried) = 34  
 $+ 5 \times 7 (= 35) = 69$ . Nine and carry six. Answer 98  
 (so far) ... .. 98  
 Third figure.— $4 \times 9 = 36 + 6$  (carried) = 42 +  $5 \times 8$   
 (= 40) = 82 +  $6 \times 7 (= 42) = 124$ . Four and carry 498  
 twelve. Answer (so far) ... .. 498  
 Fourth figure.— $5 \times 9 = 45 + 12$  (carried) = 57  
 $+ 6 \times 8 (= 48) = 105$ . Five and carry ten. Answer 5498  
 (so far) ... .. 5498  
 Fifth and sixth figures.— $6 \times 9 = 54 + 10$  (carried)  
 = 64. Answer ... .. 645498

CLIVE CUTHBERTSON.

**A Rare Phenomenon.**

I HAVE read with much interest the accounts of "the rare phenomenon" observed by several of your correspondents (published in NATURE, vol. xlv, pp. 494, 519), as I noticed a similar appearance here in Nova Scotia, at about the same time (September 11).

A narrow ray—apparently of auroral light—spanned the whole heavens from east to west, passing overhead a little to the south of the zenith. There was little or no display of auroral light in the north at the time.

A "harvest-home" was held here on September 11, and I noticed the appearance, I think, the same evening about 11 o'clock.

A number of persons in the town of Baddeck observed the same or a similar phenomenon "very shortly before September 12."

ALEXANDER GRAHAM BELL.

Beinn Breagh, near Baddeck, Cape Breton, N.S.,  
November 6.

**HENRY NOTTIDGE MOSELEY, F.R.S.**

I HAVE been asked to write for the readers of NATURE some account of my dear friend Moseley, who, after an illness which removed him from all active life and work for more than four years, died at Clevedon, in Somersetshire, on November 10. He was only forty-seven years of age; and when seized with the illness which necessitated his retirement from active life, was at the zenith of a wonderful career of scientific productiveness and value. He had for six years held the Linacre Professorship of Human and Comparative Anatomy in the University of Oxford; and by his great energy and commanding talent had succeeded in collecting around him a most promising band of younger men devoted to the investigation of embryological and morphological problems. Baldwin Spencer, Gilbert C. Bourne, S. J. Hickson, and G. Herbert Fowler, were his pupils, and have shown by their numerous published works the value of the teaching and impulse which he gave to them. In the early days of his illness (1887), he was cheered by receiving from the Royal Society the Royal Medal, in recognition of the value of his researches on Peripatus, the Hydrocorallinae, the Land Planarians, and the Chitons. The blow caused by his serious illness was felt not only in the scientific and social life of Oxford, but in many other centres. We missed his valuable and practical help in carrying to completion the Plymouth Laboratory

of the Marine Biological Association, of which he had been a most active and enthusiastic promoter; in the editorship of the *Quarterly Journal of Microscopical Science* I found myself once more deprived of the aid of my most valued comrade, as I had been but a few years previously when Frank Balfour died. The readers of NATURE and of the *Athenaeum* missed his varied and always strongly original contributions; and the Zoological, Anthropological, and Royal Societies had to regret his absence from their meetings and Councils. Moseley had, moreover, at this time made it a practice to give evening lectures in the larger provincial towns as well as in London: from all quarters came expressions of the deep regret which his retirement from public work excited. The amount and variety of work in which he engaged, in addition to the remarkable and extraordinarily minute course of lectures and laboratory work provided by him for his pupils, were certainly more than was wise for him to undertake. But it was a strange and to him a disastrous fact that he never felt tired. He was an exceedingly strong man, and I never saw him fatigued either by physical or mental exertion.

We made acquaintance in Rolleston's laboratory at the Oxford University Museum in 1866, and became fast friends and constant companions. Moseley's father was a distinguished mathematician and Canon of Bristol, Rector of Olvaston, near the Severn. Here, when I was staying with Moseley in 1871, we dissected and prepared the skeleton of a huge grampus which is now in the Oxford Museum; the carcass had made a tour of the neighbouring villages for three weeks before we obtained possession of it. Moseley was at school at Harrow, where he chiefly occupied himself in birds'-nesting and "bug-hunting," in conjunction with a small band of kindred spirits. He was essentially a sportsman, knew every kind of game and how to pursue it. He thoroughly disliked the ordinary routine of school work, such as it was in those days, and it was not until he had entered at Exeter College, and come under the teaching of the late Prof. Rolleston, that his really keen and remarkable intellectual powers began to show themselves. He had somehow developed in early youth the most deep-rooted scepticism which I ever came across among men of my own age; hence it was the reality of the work which he did in the dissecting-room at the Museum which delighted him and gave him confidence that there was "something in it" worthy of his intellectual effort. With unfeigned astonishment he would say, on dissecting out the nervous system of a mollusk or some such structure, "It is like the picture, after all!" He had a profound disbelief in the statements made in books unless he could verify them for himself, and it was this habit of mind, perceived and encouraged by Rolleston, which made him in after life so admirable an observer and so successful as a discoverer of new facts. Rolleston used to say that you had only to put down Moseley on a hill-side with a piece of string and an old nail, and in an hour or two he would have discovered some natural object of surpassing interest. He took great interest in all games, and was himself a first-rate racket-player. In the vacations he got a fair amount of shooting, and spent one "long" shooting and fishing in Norway. In the summer of 1867 we visited the Channel Islands together, for the purpose of studying marine animals. Whilst in Sark, after I had left him, he made the acquaintance of an American painter named Dix, and discovered himself to be no mean artist, bringing back a number of really clever water-colours, his first attempts in that direction. At this time and throughout his life, those who met him were struck by his singularly soft and agreeable voice, and by his great courtesy and power of interesting, I may even say fascinating, the most unpromising and unlikely of the companions amongst whom he chanced to find himself—I mean stiff old gentlemen and demure old ladies. To companions of his own age he

was fond of adopting the free discourse and chaff of school-boy days. His friendship was like that of the explorers and prairie-hunters of whom he loved to read—absolutely staunch. If you had the good fortune to be his "chum," he would stand by you through thick and thin, and share all he had with you. I do not think there was any limit to what he would have done for his friend. We took our degrees together in 1868; and in the following spring—he having been elected Radcliffe Travelling Fellow, and I Burdett-Coutts Scholar—we spent six weeks in the Auvergne and the country between that and Marseilles. In the following winter (February 1870) we took up our quarters together at Vienna, and studied with Stricker, and in Rokitsanski's laboratory. He entered, on our return, at University College, London, as a student of the Medical Faculty. In 1871, after his winter medical session, he joined me at Leipzig, where his great abilities were discerned and thoroughly appreciated by Prof. Ludwig, in whose laboratory we had the privilege of working. His first scientific memoirs were published whilst he was here—one, on the nerves of the cornea of mammals, as shown by the gold method (then not so familiar as it is now), and one on the circulation in the wing of the cockroach.

In the autumn of the same year, Moseley went, as member of the Government Eclipse Expedition, to Ceylon, under Mr. Norman Lockyer, whilst I joined Anton Dohrn at Naples. Moseley made valuable spectroscopic observations of the eclipse at Trincomali, and also brought home a large booty of Land Planarians, which he at once studied by means of sections, going to Oxford for the purpose of using the laboratory and the library attached to the Museum. This admirable piece of work delighted Rolleston, who communicated it to the Royal Society; it was published in the Philosophical Transactions after Moseley had sailed on the *Challenger*, as one of the naturalists of the Expedition, in December 1872. We did not see him again until May 1876, but I had frequent letters from him, and sometimes a small parcel, or some photographs. Of the scientific staff of the Expedition, Wyville Thomson and Suhm are dead, as well as Moseley; John Murray and J. Y. Buchanan are the two survivors. Moseley, although not a botanist, undertook the collecting of plants whenever the Expedition touched land; he also made important anthropological studies on the Admiralty Islanders, and has published a wonderful mass of notes and observations, accompanied by plates and woodcuts, in his "Notes of a Naturalist on the *Challenger*." He showed the stuff he was made of very soon after the Expedition started, viz. on the arrival of the *Challenger* at the Cape. He immediately started off in quest of *Peripatus*—a strange, imperfectly described beast which we had discussed together over some spirit specimens of it which I had received from Roland Trimen, of Cape Town. Moseley had made up his mind before he left England to "tackle" *Peripatus*, and he did so. He obtained living specimens, discovered the tracheæ and the most important features in the development, showing that the "jaws" are in-turned parapodia—and sent home a memoir which was at once published in the Philosophical Transactions. In the later part of the voyage he was occupied with the corals, and especially the Millepores and Stylasterids. The wonderfully elaborate plates, and the discovery they embodied, necessitating the formation of a new group of animals, the Hydrocorallinae, were the first-fruits of his voyage which he produced on landing in 1876. During his absence both his father and his mother had died. His old College, Exeter—where I became a Fellow in the year of the *Challenger's* departure—now was inspired through the good offices of an eminent Greek scholar, with the happy thought of offering Moseley a Fellowship and a home in the College, so that he found on landing a welcome awaiting him, and a place in which to store for a while

his treasures. I do not think that a College Fellowship was ever better bestowed: that was in the good old days before Lord Selborne's Commission. In his rooms in Exeter, Moseley displayed his Japanese and Melanesian curiosities, and wrote many papers embodying the observations made during his voyage, besides the book above mentioned. He was elected F.R.S. in 1879, and after a visit to Oregon (of which he published an account) was appointed (1879) Assistant Registrar of the University of London. He took up his residence in Burlington Gardens, but not for long. In 1881 he married the youngest daughter of Mr. J. Gwyn Jeffreys, F.R.S., the distinguished conchologist, and in the same year was elected, on the death of his teacher and close friend, Prof. Rolleston, to the Linacre Professorship in the University of Oxford.

Moseley had had no previous experience in teaching, but he set to work with that unbounded energy and strength which characterized him. He spared no pains to make his lectures absolutely up to date, and arranged a thorough laboratory course extending over two years to illustrate them. The regulations of the University as to examinations and curriculum were at that time not unfavourable to the study of animal morphology, and Moseley usually had ten or a dozen serious students besides the elementary class. Lincoln University, and New Colleges encouraged his and their efforts by offering and awarding Fellowships to students of the University distinguished in animal morphology; and after six years all was progressing as satisfactorily as possible, when he was attacked by illness which brought his work to an end. Not only was he unable to carry on his work, but his absence naturally enough was unfavourable to the interests of those studies which he would have fostered and guarded, had he been able to take part in the legislation of the University.

During the happy and busy six years which Moseley spent as Linacre Professor at Oxford, he trained Bourne, Hickson, and Fowler to carry on his coral work; with Baldwin Spencer he investigated the pineal eye of *Lacertilia*, and himself published his remarkable discovery of eyes and other sense-organs in the shells of *Chitonidæ*. He was largely instrumental in securing the Pitt-Rivers collection of anthropological objects for the University, and superintended the preliminary arrangement of the collection in the building erected for it. He served twice on the Council of the Royal Society, was a founder and member of Council of the Marine Biological Association, and was President of Section D of the British Association at the Montreal meeting.

His love of travel was shared by his wife, who went with him from Montreal to Arizona to visit the town-building Indians of that remote region, and who, only a year before his illness, accompanied him on an Easter holiday trip to Tangier and Fez. During his illness she has been his constant companion. He leaves, besides her, two daughters and a son.

E. RAY LANKESTER.

#### ON THE VIRIAL OF A SYSTEM OF HARD COLLIDING BODIES.

A RECENT correspondence has led me to examine the manner in which various authors have treated the influence of the finite size of molecules in the virial equation, and I should like to lay a few remarks upon the subject before the readers of NATURE.

To fix the ideas, we may begin by supposing that the molecules are equal hard elastic spheres, which exert no force upon one another except at the instant of collision. By calling the molecules hard, it is implied that the collisions are instantaneous, and it follows that at any moment the potential energy of the system is negligible in comparison with the kinetic energy.

If the volume of the molecules be very small in comparison with the space they occupy, the virial of the impulsive forces may be neglected, and the equation may be written

$$p v = \frac{1}{3} \Sigma m V^2, \dots \dots \dots (1)$$

where  $p$  is the pressure exerted upon the walls of the inclosure,  $v$  the volume,  $m$  the mass, and  $V$  the velocity of a molecule.

In his essay of 1873 Van der Waals took approximate account of the finite size of the molecules, using a peculiar process to which exception has been taken by Maxwell and other subsequent writers. It must be said, however, that this method has not been proved to be illegitimate, and that at any rate it led Van der Waals to the correct conclusion—

$$p(v - b) = \frac{1}{3} \Sigma m V^2, \dots \dots \dots (2)$$

in which  $b$  denotes four times the total volume of the spheres. In calling (2) correct, I have regard to its character as an approximation, which was sufficiently indicated by Van der Waals in the original investigation, though perhaps a little overlooked in some of the applications.

In his (upon the whole highly appreciative) review of Van der Waals's essay, Maxwell (NATURE, vol. x. p. 477, 1874) comments unfavourably upon the above equation, remarking that in the virial equation  $v$  is the volume of the vessel and is not subject to correction.<sup>1</sup> "The effect of the repulsion of the molecules causing them to act like elastic spheres is therefore to be found by calculating the virial of this repulsion." As the result of the calculation he gives

$$p v = \frac{1}{3} \Sigma m V^2 \left\{ 1 - 2 \log \left( 1 - \frac{\rho}{\sigma} + \frac{17 \rho^2}{\sigma^2} - \dots \right) \right\}, \dots (3)$$

where  $\sigma$  is the density of the molecules, and  $\rho$  the mean density of the medium, so that  $\rho/\sigma = b/4v$ . If we expand the logarithm in (3), we obtain as the approximate expression, when  $\rho/\sigma$  is small,

$$p v = \frac{1}{3} \Sigma m V^2 (1 + 4b/v), \dots \dots \dots (4)$$

or, as equally approximate,

$$p(v - 4b) = \frac{1}{3} \Sigma m V^2, \dots \dots \dots (5)$$

which does not agree with (2).

The details of the calculation of (3) have not been published, but there can be no doubt that the equation itself is erroneous. In his paper of 1881 (*Wied. Ann.*, xii. p. 127), Lorentz, adopting Maxwell's suggestion, investigated afresh the virial of the impulsive forces, and arrived at a conclusion which, to the order of approximation in question, is identical with (2). A like result has been obtained by Prof. Tait (*Edin. Trans.*, xxxiii. p. 90, 1886).

It appears that, while the method has been improved, no one has succeeded in carrying the approximation beyond the point already attained by Van der Waals in 1873. But a suggestion of great importance is contained in Maxwell's equation (3), numerically erroneous though it certainly is. For, apart from all details, it is there indicated that the virial of the impacts is represented by  $\frac{1}{3} \Sigma m V^2$ , multiplied by some function of  $\rho/\sigma$ , so that, if the volume be maintained constant, the pressure as a function of  $V$  is proportional to  $\Sigma m V^2$ . The truth of this proposition is evident, because we may suppose the velocities of all the spheres altered in any constant ratio, without altering the motion in any respect except the scale of time, and then the pressure will necessarily be altered in the square of that ratio.

It will be interesting to inquire how far this conclusion is limited to the suppositions laid down at the commence-

ment. It is necessary that the collisions be instantaneous, in relation, of course, to the free time. Otherwise, the similarity of the motion could not be preserved, the duration of a collision, for example, bearing a variable ratio to the free time. On the same ground, vibrations within a molecule are not admissible. On the other hand, the limitation to the spherical form is unnecessary, and the theorem remains true whatever be the shape of the colliding bodies. Again, it is not necessary that the shapes and sizes of the bodies be the same, so that application may be made to mixtures.

In the theory of gases,  $\Sigma m V^2$  is proportional to the absolute temperature; and whatever doubts may be felt in the general theory can scarcely apply here, where the potential energy does not come into question. So far, then, as a gas may be compared to our colliding bodies, the relation between pressure, volume, and temperature is

$$p = T \phi(v), \dots \dots \dots (6)$$

where  $\phi(v)$  is some function of the volume. When  $v$  is large, the first approximation to the form of  $\phi$  is

$$\phi(v) = \frac{A}{v}.$$

In the case of spheres, the second approximation is

$$\phi(v) = \frac{A}{v} + \frac{A b}{v^2},$$

where  $b$  is four times the volume of the spheres.

Thus far we have supposed that there are no forces between the bodies but the impulses on collision. Many and various phenomena require us to attribute to actual molecules an attractive force operative to much greater distances than the forces of collision, and the simplest supposition is a cohesive force such as was imagined by Young and Laplace to explain capillarity. We are thus led to examine the effect of forces whose range, though small in comparison with the dimensions of sensible bodies, is large in comparison with molecular distances. In the extreme case, the influence of the discontinuous distribution of the attractive centres disappears, and the problem may be treated by the methods of Laplace. The modification then required in the virial equation is simply to add <sup>1</sup> to  $p$  a term inversely proportional to  $v^2$ , as was proved by Van der Waals; so that (6) becomes

$$p^\lambda = T \phi(v) - \alpha v^{-2}, \dots \dots \dots (7)$$

According to (7), the relation between pressure and temperature is linear—a law verified by comparison with observations by Van der Waals, and more recently and extensively by Ramsay and Young. It is not probable, however, that it is more than an approximation. To such cases as the behaviour of water in the neighbourhood of the freezing-point it is obviously inapplicable.

In their discussions, Ramsay and Young employ the more general form—

$$p = T \phi(v) + \chi(v); \dots \dots \dots (8)$$

and the question arises, whether we can specify any generalization of the theoretical conditions which shall correspond to the substitution of  $\chi(v)$  for  $\alpha v^{-2}$ . It would seem that, as long as the only forces in operation are of the kinds, impulsive and cohesive, above defined, the result is expressed by (7); and that if we attempt to include forces of an intermediate character, such as may very probably exist in real liquids, and must certainly exist in solids, we travel beyond the field of (8), as well as of (7). It may be remarked that the equation suggested by Clausius, as an improvement on that of Van der Waals, is not included in (8).

<sup>1</sup> It thus appears that, contrary to the assertion of Maxwell,  $\phi$  is subject to correction. It is pretty clear that he had in view an attraction of much smaller range than that considered by Van der Waals.

<sup>2</sup> In connection with this it may be worth notice that for motion in one dimension the form (2) is exact.

Returning to the suppositions upon which (7) was founded, we see that, if the bodies be all of one *shape*, e.g. spherical, the formula contains only two constants—one determining the size of the bodies, and the second the intensity of the cohesive force; for the mean kinetic energy is supposed to represent the temperature in all cases. From this follows the theorem of Van der Waals respecting the identity of the equation for various substances, provided pressure, temperature, and volume be expressed as fractions of the critical pressure, temperature, and volume respectively. If, however, the *shape* of the bodies vary in different cases, no such conclusion can be drawn, except as a rough approximation applicable to large volumes. RAYLEIGH.

Terling Place, Witham, November 18.

### THE IMPLICATIONS OF SCIENCE.<sup>1</sup>

#### II.

I MIGHT now at once return to further consider those implications of science to which I have called your attention, but I think it will be better to first briefly pass two important matters in review.

The first concerns our means of investigation as to such fundamental questions.

The second relates to our ultimate grounds for forming judgments about them. We have to consider how fundamental truth can be acquired and tested.

Evidently the only means of which we can make use are our *thoughts*, our reason, our intellectual activity. "Thoughts" may be, and should be, carefully examined and criticized; but however much we may do so, and whatever the results we arrive at, such results can only be reached by thoughts, and must be expressed by the aid of our thoughts. This will probably seem such a *manifest* truism that I shall be thought to have committed an absurdity in enunciating it. To suppose that by any reasoning we can come to understand what we can never think, may seem an utterly incredible folly; yet at a meeting of a Metaphysical Society, in London, a speaker, not long ago, expressly declared "thought" to be a misleading term, the use of which should be avoided.

Now I am far from denying that unconscious activities of various different orders take place in our being, yet whatever influence such activities may have they cannot affect our judgments save by and in thoughts.

If a man is convinced that thoughts are worthless tools, he can only have arrived at that conclusion by using the very tools he declares to be worthless. What, then, ought his conclusion to be worth even in his own eyes?

It is simply impossible by reason to get behind or beyond conscious thought, and our thoughts are and must be our only means of investigating problems however fundamental.

Even in investigating the properties of material bodies, it is to self-conscious reflective thought that our final appeal must be made.

For it is to our thoughts, and not to our senses only, that our ultimate appeal must be made, even with respect to the most material physical science matters.

Some persons may imagine that with respect to investigations about the properties of material bodies, it is to our sensations alone that we must ultimately appeal. But it is not so; anyone would be mad to question the extreme importance, the absolute necessity, of our sensations in such a case. Nevertheless, after we have made all the observations and experiments we can, how can we know we have obtained such results as we may have obtained, save by our self-conscious thought? By what

other means are we to judge between what may seem to be the conflicting indications of different sense impressions?

Our senses are truly tests and causes of certainty, but not *the* test. Certainty belongs to thought, and self-conscious reflective thought is our ultimate, absolute criterion.

As to the ultimate grounds on which our judgments respecting such problems must repose, as Mr. Arthur Ballou has forcibly pointed out, that it is a question altogether distinct from that of the origin of our judgments, or from reasonings about their truth. Such matters are very interesting, but they are not here in point, since it is plain that no proposition capable of proof can be one the certainty of which is fundamental. For, in order to prove anything by reasoning, we must show that it necessarily follows as a consequence from other truths, which therefore must be deemed more indisputable. But the process must stop somewhere. We cannot prove everything. However long our arguments may be, we must at last come to ultimate statements, which must be taken for granted, like the validity of the process of reasoning itself, which is one of the implications of science. If we had to prove either the validity of that process or such ultimate statements, then either he must argue in a circle, or our process of proof must go on for ever without coming to a conclusion, which means there could be no such thing as "proof" at all.

Therefore the "grounds of certainty" which any fundamental proposition may possess cannot be anything *external* to it—which would imply this impossible proof. The only ground of certainty which an ultimate judgment can possess is its own *self-evidence*—its own manifest certainty *in and by itself*. All proof, all reasoning, must ultimately rest upon truths which carry with them their own evidence, and do not therefore need proof.

It is possible that some of my hearers may be startled at the suggestion of believing anything whatever on "its own evidence," fancying it is equivalent to a suggestion that they should believe anything *blindly*. This, I think, is due to the following fact of mental association. The immensely greater part of our knowledge is gained by us indirectly—by inference or testimony of some kind.

We commonly ask for some proof with regard to any new and remarkable statement, and no truths are brought more forcibly home to our minds than are those demonstrated by Euclid. Thus it is that many persons have acquired a feeling that to believe anything which cannot be proved, is to believe *blindly*. Hence arises the tendency to distrust what is above and beyond proof. We are apt to forget, what on reflection is manifest—namely, that if it is not blind credulity to believe what is evident to us by means of something else, it must be still less blind to believe that which is directly evident in and by itself.

And self-conscious reflective thought tells *me* clearly, that the law of contradiction is not only implied by all science, and necessary to the validity of all science, but that it is, as I said, an absolute, necessary truth which carries with it its own evidence. It must be a truth, then, applicable both to the deepest abyss of past time and the most distant region of space. But here, again, I think it possible that one or two of my hearers may be startled, and perhaps doubting how things in this respect may be in the Dog-star now, or how they were before the origin of the solar system. I fancy I hear someone asking: "How is it possible that we, mere insects, as it were, of a day, inhabiting an obscure corner of the universe, can know that anything is and must be true for all ages and every possible region of space?"

In the first place, I think the difficulty which may be thus felt is due to the abstract form of the law of contradiction. And yet, as I said before, it is but the summing up of all the particular instances, as to each one of which no difficulty at all is felt, but each is clearly

<sup>1</sup> Friday Evening Discourse delivered at the Royal Institution by Dr. St. George Mivart, on June 5, 1891. Continued from p. 62.

seen to be true. Any man who really doubted whether, if his legs were cut off, they might not at the same time remain on, would have a mind in a diseased condition.

There is, however, another reason which indisposes some persons to see the necessary force of this law. It is due, I think, to a second fact of mental association.

Things which are very distant, or which happened a long time ago, are known to us only in roundabout ways, and we often feel more or less want of certainty about them. On the other hand, we have a practical certainty concerning the things which are about us at any given moment. Thus we have come to associate a feeling of uncertainty with statements about things very remote. But nothing can well be more remote from us than "the most distant regions of space" or "before the origin of the solar system." It is not surprising, then, that this mental association should call forth a feeling of uncertainty with respect to any statement about universal truth.

It is, no doubt, wonderful that we should be able to know any necessary and universal truths; but it is less exceptionally wonderful, when we come to think the matter all round, than it may at first sight appear to be. It is wonderful; but so, deeply considered, is all our knowledge. It is wonderful that through molecular vibrations, or other occult powers of bodies, we have sensations—such as of musical tones, sweetness, blueness, or what not. It is wonderful that through sensations, actual and remembered, we have perceptions. It is wonderful that on the occurrence of certain perceptions we recognize our own existence past and present. So, also, it is wonderful that we recognize that what we know "*is*," cannot at the same time "not be." The fact is so, and we perceive it to be so; we know things, and we know that we know them. How we know them is a mystery, indeed, but one about which it is, I think, perfectly idle to speculate. It is precisely parallel to the mystery of sensation. We feel things savoury, or odorous, or brilliant, or melodious, as the case may be, and with the aid of the scalpel and the microscope we may investigate the material conditions of such sensations. But *how* such conditions can give rise to the feelings themselves is a mystery which defies our utmost efforts to penetrate. I make no pretension to be able to throw any light upon the problem "How is knowledge possible?" any more than on the problem "How is sensation possible?" or on the questions "How is life possible?" or "How is extension possible." But "*Ignorantia modi non tollit certitudinem facti.*" And we know that we are living, that we feel, and that we do know something—if only that we know we doubt about the certainty of our knowledge.

And *à propos* of such doubt, let me here put before you the intellectual penalties which have to be paid for any *real* and *serious* doubt with respect to the implications of science. I think we shall see that nothing less than intellectual suicide or mental paralysis must be the result. And such a result must also be logically fatal to every branch of science. The first implication I put before you was the *validity of inference*.

Now, no one who argues, or who listens to or reads—with any serious intention—the arguments of others, can, without stultifying himself, profess to think that no process of reasoning is valid. If the truth of no mode of reasoning is certain, if we can make no certain inferences at all, then all arguments must be useless, and to proffer, or to consider, them must be alike vain. But not only must all reasoning addressed to others be thus vain, the silent reasoning of solitary discursive thought must be vain also. Yet what does this amount to save an utter paralysis of the intellect? It is scepticism run mad.

But the implication I regard as one of the most important of all is the implication of *our knowledge of our own continuous existence*, concerning which I said I must crave your permission to speak at some length. It was the mention of this implication which led me to

refer to that system of thought it is my object here to controvert.

I have heard it proclaimed in this theatre by Prof. Huxley that we cannot have supreme certainty as to our own continuous existence, and that such knowledge is but secondary and subordinate to our knowledge of our present feelings or "states of consciousness."

Of course I am not thus accusing him of *originating* any such erroneous view. In that matter he is but a follower of that daring and playful philosopher Hume. I say "playful," because I cannot myself think that he really believed his own negations. He seems to me too acute a man to have been himself their dupe. But however this may be, I here venture directly to contradict Hume's and Prof. Huxley's affirmation, which is also adopted by Mr. Herbert Spencer, and to affirm that we have the *highest* certainty as to our own continuous existence.

It is, of course, quite true that we have complete certainty about our present feelings, as also that we cannot know ourselves apart from our feelings. But it is no less true that we cannot be conscious of feelings apart from the "self" which has those feelings. Now, it is assumed by those I oppose that we can know nothing with absolute certainty unless we know it by itself or "unmodified," or as existing "*absolutely.*" But in fact nothing, so far as we know, exists apart from every other entity and unmodified—or "*absolutely,*" as it is, in my opinion, absurdly called. No wonder, then, if we do not know things in a way in which they never do, and probably never can, exist. We can really know nothing by itself because nothing exists by itself. It is not wonderful, then, if we only know ourselves as related to our simultaneously known feelings, or *vice versa*.

It is quite true that we never know our own substantial essential being alone and unmodified, but then we have never for an instant so existed. Our knowledge of ourselves in this respect is like our knowledge of anybody and everybody else. Most persons here present doubtless know Prof. Tyndall, yet they never knew him, no one ever knew him, except in some "state"—either at home or away from home, either sitting or not sitting, either in motion or at rest, either with his head covered or uncovered—and this for the very good and obvious reason that he never did or could exist for a moment save in some "state." But this does not prevent your knowing him very well, and the same consideration applies to our knowledge of ourselves. When I consider what is my primary, direct consciousness at any moment, I find it to be neither a consciousness of a "state of feeling" nor of my "continuous existence," but a consciousness of doing something or having something done to me—action or reaction. I have always, indeed, some "feeling" and also some sense of my "self-existence"; but what I perceive primarily, directly, and immediately is neither the "feeling" nor the "self-existence," but some concrete actual doing, being, or suffering then experienced. We can, indeed, become distinctly and explicitly aware of either the "feeling" or the "self-existence" by turning back the mind upon itself. But to know that one "has a feeling" or is in a "state," or even that a "feeling exists," is plainly an act by which no one begins to think. It is evidently a secondary act—an act of reflection. No one begins by perceiving his perception a bit more than he begins by expressly adverting to the fact that it is he himself who perceives it.

Let us suppose two men to be engaged in a fencing match. Each man, while he is parrying, lunging, &c., has his "feelings" or "states," and knows that it is "he" who is carrying on the struggle. Yet it is neither his "*mental states*" nor the "*persistence of his being*" which he directly regards, but his concrete activity—what he is doing and what is being done to him. He may, of course, if he chooses, direct his attention either to the feelings

he is experiencing or to his underlying continuous personality. Should he do so, however, a hit from his adversary's foil will be a probable result.

But to become aware that one has any definite feeling is a reflex act *at least* as secondary and posterior as it is to become aware of the "self" which has the feeling. I say "*at least*," but I believe that of the two perceptions (1) of "feelings," and (2) of "self," it is the "self" which is the *more* prominently given in our primary, direct cognitions.

I believe that a more laborious act of mental digging is requisite to bring *explicitly* to light the *implicit* mental state, than to bring forward *explicitly* the *implicit* "self-existence." Men continually and promptly advert to the fact that actions and sufferings are *their own*, but do not by any means so continually and promptly advert to the fact that the feelings they experience are "*existing feelings*."

Therefore I am convinced that one of the greatest and most fundamental errors of our day is the mistake of supposing that we can know our "mental states" or "feelings," more certainly and directly than we can know the continuously existing self which has those feelings.

Our perception of our continuous existence also involves the *validity of our faculty of memory*, which is implied in this way, as well as in every scientific experiment we may perform. For we cannot obviously have a reflex perception either of our "feelings" or our "self-existence," without trusting our memory as to the past; since, however rapid our mental processes may be, no mental act takes place without occupying some period of time, and, indeed, nervous action is not extremely rapid. In knowing, therefore, such facts by a reflex act, we know by memory what is already past. Thus our certainty as to our own continuous existence necessarily carries with it a certainty as to our faculty of memory. Therefore, the mental idiocy of absolute scepticism is the penalty that has to be paid for any *real* doubt about our own existence or the trustworthiness of the *faculty of memory*, for all our power of reposing confidence in our observations, experiments, or reasonings, would, in that case, be logically at an end. On the other hand, the validity of our faculty of memory establishes once for all (as we have seen) the fact that we can transcend our present consciousness and know *real objective truth*.

Let us now see the consequences of the denial, or *real* doubt of the second implication of science—the "law of contradiction." Without it we can be certain of nothing, and it therefore lands us in absolute scepticism. And if we would rise from that intellectual paralysis we must accept that dictum as it presents itself to our minds; and the dictum presents itself to my mind, not as a law of *thought* only, but a law of *things*. It affirms, for example, that no creature anywhere or anywhere can at the same time be both bisected and entire.

An amusing instance of the way in which very distinguished men may be misled as to the question of our power of perceiving necessary truth is offered by an imaginary case which has been put forward by Prof. Clifford and Prof. Helmholtz. Their object in advancing it was to show, by an example, how truths which appear necessary to us are not objectively necessary. But the result appears to me to show the direct contradictory of what they intended. Their intention evidently was to support the proposition that we can know "*no truths to be absolutely necessary*," and the result is to show that, even according to them, "*some truths are absolutely necessary*." The necessary truths they propose to controvert are that "a straight line is the shortest line between two points," and that "two straight lines cannot inclose a space."

For this purpose, curious creatures, possessing length

and breadth but no thickness, were supposed, by them, to be living on a sphere with the surface of which their bodies would coincide. They were imagined to have experience of length and breadth in curves, but none of height and depth, or of any straight lines. To such creatures, it was said, our geometrical necessary truths would not appear "truths" at all. A straight line for them would not be the shortest line, while two parallel lines prolonged would inclose a space.

To this imaginary objection I reply as follows:—"Beings so extraordinarily defective might, likely enough, be unable to perceive geometrical truths which to less defective creatures—such as ourselves—are perfectly clear. Nevertheless, *if they could conceive of such things* at all, as those we denote by the terms 'straight lines' and 'parallel lines,' then there is nothing to show that they could not also perceive those same necessary truths concerning them which are evident to us."

It is strange that the very men who make this fanciful objection, actually show, by the way they make it, that they themselves perceive the necessary truth of those geometrical relations the necessity of which they verbally deny. For how, otherwise, could they affirm what would or would not be the necessary results attending such imaginary conditions? How could they confidently declare what perceptions such conditions would certainly produce, unless they were themselves convinced of the validity of the laws regulating the experiences of such beings? If they affirm, as they do, that they perceive what must be the truth in their supposed case, they thereby implicitly assert the existence of some absolutely necessary truths, or else their own argument itself falls to the ground.

But this same implication of science, respecting the objective absolute validity of the law of contradiction, also refutes that popular system of philosophy which declares that all our knowledge is merely relative, and that we can know nothing as it really exists independently of our knowledge of it, the system which proclaims the "*relativity of knowledge*."

Of course anything which is "*known to us*" cannot at the same time be "*unknown to us*," and so far as this, our knowledge may be said to affect the things we know. But this is trivial. Our "knowing" or "not-knowing" any object is—apart from some act of ours which results from our knowledge—a mere accident of that body's existence, which is not otherwise affected thereby.

Again, as I before remarked, nothing, so far as we know, exists by itself, and unrelated to any other thing. To say, therefore, that "all our knowledge is relative" might only mean that knowledge concords with objective reality. But this is by no means what the upholders of the "relativity of knowledge" intend to signify. They deny the objective validity, the actual correspondence with reality, of any of our perceptions or convictions—even, as Mr. Herbert Spencer tells us, our cognition of "difference."

Every system of knowledge, *however*, must start with the assumption, implied or expressed, that something is true. By the teachers of the doctrine of the "relativity of knowledge" it is evidently taught that the doctrine of the relativity of knowledge is true. But if we cannot know that anything corresponds with external reality, if *nothing* we can assert has more than a relative or phenomenal value, then this character must also appertain to the doctrine of the "relativity of knowledge." Either this system of philosophy is merely relative or phenomenal, and cannot be known to be true, or else it is absolutely true, and can be known so to be. But it must be merely relative and phenomenal, if everything known by man is such. Its value, then, can be only relative and phenomenal, therefore it cannot be known to correspond with external reality, and cannot be asserted to be true; and anybody who asserts that we can know it to be true,

thereby asserts that it is false to say that our knowledge is only relative. In that case some of our knowledge must be absolute; but this upsets the foundation of the whole system. Anyone who upholds such a system as this may be compared to a man seated high up on the branch of a tree which he is engaged in sawing across where it springs from the tree's trunk. The position taken up by such a man would hardly be deemed the expression of an exceptional amount of wisdom.

My time has expired, and I may say no more. The considerations I have put before you this evening, should they commend themselves to your judgment, will, I think, lead you to admit that, if we feel confidence and certainty in any part of any branch of physical science, we thereby implicitly affirm that the human mind can, by consciousness and memory, know more than phenomena—can know some objective reality—can know its own continuous existence—the validity of inference and the certainty of universal and necessary truth as exemplified in the law of contradiction. In other words, the system of the relativity of knowledge is untrue. Thus the dignity of that noble, wonderful power, the human intellect, is fully established, and the whole of our reason, "from turret to foundation-stone," stands firmly and secure. If I have succeeded in bringing this great truth home to one or two of my hearers who before doubted it, I am abundantly repaid for the task I have undertaken. It only remains for me now to thank you for the kind and patient hearing you have been so good as to accord me.

#### EXAMINATIONS IN SCIENCE.

THE Committee of the Privy Council on Education have just announced an important decision with regard to the examinations of the Science and Art Department in science.

The number of candidates presenting themselves for examination in science is already so large—about 100,000 papers in various branches of science were worked at the examination in May last, besides above 14,000 practical examinations—that the machinery of examination and registration is already severely strained. These numbers will in all probability soon be so increased as to render it impossible to make satisfactory arrangements for the examination of the candidates at the local centres, or for the examination of the worked papers under any system of central examination.

At the same time the means recently placed at the disposal of local authorities for providing or aiding instruction seem to render it unnecessary for the Science and Art Department to continue to give direct aid for very elementary instruction in science. Such instruction can now be more effectually organized and maintained locally.

Under these circumstances it has been decided that after the May examinations of 1892 the payments of £1 now made for the second class in the elementary stage of each science subject shall cease.<sup>1</sup> An elementary paper will continue to be set in each subject, but the results will be recorded simply as *pass* or *fail*, the standard for passing being about the same as that now required for a first class, *i.e.* about 60 per cent. of the marks obtainable.

At the same time, with a view to encourage more advanced instruction, which does not seem to be adequately provided for at present, the payments for the advanced stage and for honours will be considerably increased. The payments on results will then be £2 for a pass in the elementary stage; £5 and £2 10s. for a first or second class respectively in the advanced stage; and £8 and £4 for a first or second class respectively in honours, in each subject of science, and in each subdivision of

subject 6, theoretical mechanics, or of subject 8, sound, heat, and light, with the following exceptions:—The payments for practical chemistry will be £3 for a pass in the elementary stage, and £6 and £3 10s. respectively for a first or second class in the advanced stage; the payments for mathematics will be £2 for a pass in stage 1, £3 and £2 respectively for a first or second class in stages 2 and 4, £4 and £3 for a first or second class respectively in stage 3, £5 and £4 for a first or second class respectively in stages 5, 6, and 7, and £8 and £4 respectively for a first or second class in honours. The payment for section 1 (geometrical drawing) of subject 1 will remain as at present, 10s.

The payment for attendance in an organized science school will be increased to £1 in the day school and 10s. in the night school.

As it is of great importance to prevent large numbers of wholly unqualified candidates being presented at the examinations, the examiners will be instructed to note the papers of all such as would not obtain above twenty-five per cent. of the marks, and a deduction will be made from the grant to each school for each such paper sufficient to cover the cost incidental to its examination.

The committee of a science school in a place in Great Britain with less than 5000 inhabitants which does not receive aid from the local authority, or of any science school in Ireland, will be allowed to continue until further notice on the present system, if they so desire it.

#### NOTES.

THE subject of an International Congress of Electricity, to be held at Chicago in connection with the World's Fair, continues to attract much attention in America. A report about the matter has been presented to the Director-General of the Exhibition by Mr. J. Allen Hornsby, secretary of the department of electricity. During a recent visit to Europe, Mr. Hornsby discussed the question with several leading men of science in England and on the Continent, and he was encouraged by them to believe that, if certain conditions were complied with, the success of the Congress would be certain. They all agreed that the Congress should be held under the auspices of the U.S. Government. Invitations, they thought, should be issued by the Government to individual scientific men through the Governments of the countries to which the individuals belong. "This course of action," says Mr. Hornsby, "in the opinion of the authorities whom I consulted, will insure an official character to the proceedings of the scientific Congress, and will virtually pledge the various Governments to a recognition and adoption of the standards created."

PROF. JOSEPH WOLSTENHOLME, whose name was well known to mathematicians, died on November 18 in his sixty-third year. He graduated at Cambridge as third wrangler in the Mathematical Tripos of 1850, and became a Fellow first of St. John's College, then of Christ's, where he was for many years a member of the tutorial staff. After vacating his Fellowship by marriage in 1869, he was appointed the first Professor of Mathematics in the Engineering College at Cooper's Hill—a position from which failing health compelled him to withdraw a year or two ago. With the Rev. Percival Frost, he wrote a treatise on solid geometry, published in 1863. He also collected many original mathematical problems, devised by himself, in a volume which appeared in 1867, and again in 1878.

WE regret to announce the death of Mr. S. F. Downing, Principal of the Civil Engineering College, Seebpur, Calcutta, which took place at Coonoor, Madras, on October 16 last, at the comparatively early age of forty-seven. The *Englishman* of October 24 says:—"The deceased gentleman was educated at Trinity College, Dublin, and was a graduate of Dublin

<sup>1</sup> The payments on the results of the examinations in 1892 will not be affected by this Minute.

University in Arts and Engineering. He came out to India in 1869 as Professor of Civil Engineering in the Engineering Department of the Presidency College, Calcutta, and when that Department was amalgamated in 1880 with the Dehree Training School, and transferred to Seebpur with the title of Government Engineering College, Mr. Downing was chosen as first Principal of the new College. In no College in Bengal has so strict a system of discipline been introduced. The beneficial results of that system, consistently adhered to in the face of strong native opposition, have long been apparent; and the present flourishing condition of the College affords the best monument which could be erected to the indomitable perseverance and uniform justice of the administration of its late Principal."

The death of Mr. Thomas Wharton Jones, F.R.S., is announced. He was nearly eighty years of age. Prof. Huxley, who was one of his pupils forty years ago, gives in the *British Medical Journal* a bright and pleasant account of his intercourse with his "old master."

The third series of Hooker's "Icones Plantarum" (vols. xi.-xx. of the whole work) is now complete, and the Bentham Trustees, who are continuing the work under the editorship of Prof. D. Oliver, are offering a limited number of sets of this series of ten volumes, for £5 the set. It contains figures of a thousand new plants, including the most interesting discoveries of the last thirty years, and the most striking of the new genera described by Bentham and Hooker during the progress of their "Genera Plantarum." As the whole impression consists of only 250 copies, the work will soon become unobtainable. Thanks to the provision made by the late Mr. Bentham, the trustees are issuing a fourth series at the rate of one volume, of 100 plates, annually, at the very low price of 16s. Persons wishing to secure a copy of the third series should apply at once to Dulau and Co., 37 Soho Square, W.

The external part of the laboratory which is being built in the Paris Museum of Natural History for Prof. Chauveau, from the designs provided by him, is now being finished. This laboratory will be used only for original research in physiology and bacteriology, and when completed will be the finest laboratory in France. But the Museum is deeply in debt, and this may cause some delay.

MEMBERS of the Royal Microscopical Society, and the several London and provincial Societies of a kindred nature, have been invited to subscribe to a fund for the benefit of the family of the late Mr. John Mayall. An influential Committee has been formed to secure the success of the scheme. Communications should be addressed to Mr. T. Curties, treasurer to the Committee, 244 High Holborn, W.C. The Committee has issued a circular setting forth Mr. Mayall's great services to the science of microscopy.

ACCORDING to a telegram despatched to the *Standard* from Bangkok on Monday night, Chaiya and Bandon, towns situated on the coast of the Gulf of Siam, have been practically destroyed by a cyclone. The loss of life is estimated at three hundred.

SOME details of the earthquake which caused so much havoc in Japan at the end of October have been received. A large part of the Empire was affected, the shocks being strongly felt in no fewer than thirty-one provinces. In the provinces of Ezaki, Mino, and Owari, several towns and villages were ruined, 3400 persons being killed and 43,000 houses destroyed. An up train and a down train on the Tokaido Railway were just meeting at the station of Gifu when the first shock was felt there. It was accompanied by subterranean rumblings and violent oscillation, which put the passengers of the train into a great state of alarm. They were further terrified by seeing cracks in the earth, two or three feet wide, opening and closing

in all directions, some of which threw up volcanic mud and ashes. A number of the passengers alighted and made their way into the town. Many houses had already fallen, and immense heaps of ruins were visible on every side. Other buildings which were then standing were so severely shattered that further earth-tremors which followed threw them to the ground. There was a marked subsidence of the earth for a considerable area round Gifu. Very soon after the houses collapsed, and while hundreds of persons remained buried under the ruins, flames burst out and spread with such rapidity that the citizens were compelled to desist from the work of rescue. The fire was not subdued until the next morning, when it was found that almost the whole town had been destroyed. The potteries in the prefectures of Owari and Mino, and at Seto and other towns, were reduced to ruins. At Gobo, a temple belonging to the Shin sect of the Buddhists, which was crowded with persons, suddenly collapsed, burying fifty of the worshippers. A slight shock occurred at Nagerio on the night of October 25. On the following Wednesday morning, while forty Christians were assembled in the Methodist school, the building began to totter, and the worshippers fled, several being killed or fatally injured. Many streets were blocked with fallen houses, and others were rendered all but impassable by the crowds of panic-stricken people who were endeavouring to make their escape. Hundreds of persons were killed by the collapse of a thread factory, and a large brick building. A castle four hundred years old, however, remained intact and suffered no damage. It is estimated that in the three towns comprising the city of Nagoya from 750 to 1000 persons lost their lives. From the time of the first disturbance up to the morning of October 30, no fewer than 368 distinct shocks were reported. Fissures 2 feet wide and several feet deep appeared in the earth, while railway metals were twisted, iron bridges broken, river embankments engulfed or destroyed, and fields flooded. A lake 600 yards long and 60 wide was formed at the foot of the Hukusan Mountain in the Gifu prefecture, and great cracks were formed in the ground near the hills. Water sprang from the cracks, and that in the wells was changed to a brownish tint and rendered unfit for drinking. The embankments of most of the rivers were destroyed, and in the Gifu district it will be necessary to rebuild them for a distance of 350 miles. The general appearance of the Mizushima division of the Mortosu district underwent a complete transformation, and at Nogo in one district there was a marked subsidence of the earth. Of 700 temples in the Gifu prefecture, over one-third were destroyed, and it will take many months to repair the river embankments. In some parts of the town of Gifu boiling mud spouted from the fissures for over two hours. The top of the sacred mountain of Fujiyama was rent asunder, a chasm being formed 1200 feet wide and 600 feet deep.

In a special report to the Secretary of Agriculture, Mr. Mark W. Harrington, Chief of the U.S. Weather Bureau, has presented a general summary of the operations of the Weather Bureau during the three months which followed its transfer to the Department of Agriculture on July 1, 1891. The Service has been reorganized with a view of carrying out the expressed intention of Congress to develop and extend its work with special reference to agriculture. The office force in Washington has been formed into three principal divisions, called respectively the Executive Division, the Records Division, and the Weather-Crop Bulletin and State Weather Service Division. Outside of Washington, local forecast officials have been appointed, the person chosen being in every case selected from the most experienced and competent observers of the Service. These officials have been placed in the larger cities, with authority to make predictions for their stations and vicinity, giving the weather more in detail than the Washington fore-



casts. They are instructed to make a careful study of the climatology of their respective sections, both for their own use as an aid in predicting and for publication for the information of the public; and they are directed to give particular attention to the effect of the weather on the principal crops at their various stages of growth, so as to be able to include in their forecasts reference to this all-important subject. A vast improvement has been effected in the weather maps issued at nearly all the more important stations. They contain not only the forecasts prepared at Washington and the local forecasts, but the data on which the forecasts are based. With regard to weather-signal display stations, Mr. Harrington makes a most striking statement. On June 30 there were about 630 stations to which the forecasts were telegraphed. On September 30 the number was 1200—an increase of about 100 per cent.; and large numbers of new stations are being rapidly established. Altogether, the Bureau is evidently in a state of high efficiency, and has profited largely by the attention which has lately been devoted to it by Congress.

MR. HARRINGTON refers in his report to the enormous accumulation of meteorological records now in the U.S. Weather Bureau. These include the observations for the twenty years during which the meteorological work was in the charge of the Signal Service, and also those for the many preceding years when it was in the charge of the Smithsonian Institution. Mr. Harrington proposes to utilize these data by special studies by officers of the Bureau. He also desires that they may be thrown open to all students of meteorology who are competent to use them, subject only to such restrictions as may suffice to preserve them from injury.

REFERRING to the International Conference of Meteorologists at Munich, Mr. Harrington notes that it was attended by four American delegates, of whom he himself was one. He was much pleased with the cordial way in which European meteorologists expressed appreciation of the meteorological work done in the United States. He speaks especially of the interest excited among students on this side of the Atlantic by the international bibliography of meteorology, begun by General Hazen and published in part by General Greely. "Evidently," he says, "the general sentiment in Europe is to the effect that the work thus far done by the Signal Office is too important to be left unfinished, and that the interests of meteorology and of climatology alike demand that the Weather Bureau should publish the complete work in proper style, after obtaining from European co-labourers all possible corrections to the manuscript that has already been mimeographed." Mr. Harrington studied closely the meteorological methods adopted in Europe; and he was particularly struck by the fact that the study of climate has, in general, been prosecuted by European meteorologists to a degree of refinement that has not yet been attained, and is, perhaps, scarcely appreciated, in America. For instance, an eminent climatologist, criticizing the location of some instruments on a rise of ground and amid trees, possibly a hundred feet above the surrounding plain, objected that these instruments could not represent properly the climate of the surrounding country, but that they should have been placed in the open flat fields near at hand. "If this person be correct," says Mr. Harrington, "it is evident that the demands of agricultural climatology are very different from those of dynamic meteorology or the study and prediction of daily weather, and it will be an important result of our European journey if we shall have received a decided stimulus in the direction of minute climatology."

DR. E. BIESE, the Director of the Meteorological Office of Finland, has published the observations taken at Helsingfors during the year 1890. In addition to the ordinary hourly

observations and summaries, the volume contains hourly values of atmospheric electricity. Owing to want of funds, the publication of the observations had ceased with those for 1883; but a fresh subsidy to the institution has been granted by a decree of the Emperor, so that the publication will be continued regularly in future, and the arrears also worked off. A summary shows that in 1890 rain fell on 178 days and snow on 84 days. The temperature varied from 74°·5 in June to 5°·3 in November, giving an annual range of 69°·2.

In a recent paper on the camel (*Zeits. für wiss. Geogr.*) Herr Lehmann refers, among other things, to its relations to temperature and moisture. Neither the most broiling heat, nor the most intense cold, nor extreme daily or yearly variations hinder the distribution of the camel. It seems, indeed, that the dromedary of the Sahara has better health there than in more equably warm regions; though, after a day of tropical heat, the thermometer sometimes goes down several degrees below freezing-point, and daily variations of 33°·7 C. occur. In Semipalatinsk again, where the camel is found, the annual variation of temperature sometimes reaches 87°·3. In Eastern Asia, winter is the time the animals are made to work. In very intense cold, they are sewn up in felt covers. Of course each race of camel does best in the temperature conditions of its home: a Soudan camel would not flourish in North-East Asia. Camels are very sensitive to moisture. In the region of tropical rains they are usually absent, and if they come into such with caravans, the results of the rainy season are greatly feared. The great humidity of the air explains the absence of the camel from the northern slopes of the Atlas, and from well-wooded Abyssinia. This sensitiveness expresses itself in the character of different races. The finest, most noble-looking camels, with short silk-like hair, are found in the interior of deserts (as in the Tuarek region, in North Africa), and they cannot be used for journeys to moist regions. Even in Fezzan (south of Tripoli) the animals are shorter and fatter, with long coarse hair; and in Nile lands, and on coasts, it is the same. These animals, too, are less serviceable as regards speed and endurance. Herr Lehmann states it as a law that the occurrence of the camel finds its limits wherever the monthly average vapour tension in the air exceeds 12 mm.

LAST week Prof. Cossar Ewart lectured on "Scottish Zoology" to the newly-formed Edinburgh University Darwinian Society, of which he is President. Having given an account of some of the eminent investigators who have devoted themselves to zoology in Scotland, Prof. Ewart spoke of the need for the encouragement of research at the Scottish Universities. In the case of his own department, it ought, he thought, to be possible for him to say to any exceptionally able student, after the completion of his curriculum, "If you are willing to remain for a year or more, I shall be glad to recommend your being elected a research scholar, and to arrange for your obtaining a small sum from a research fund to provide material, &c., required in any investigation you may undertake." Were there two research scholars, or even but one, at work in each of the scientific departments, Prof. Ewart thinks the Scottish Universities would, before long, have a reputation altogether higher and grander than they at present enjoy, to the gain of science and, in all probability, the further amelioration of humanity.

In his interesting Rectorial address, at Edinburgh, on the use of the imagination, Mr. Goschen referred to the need for imaginative activity in the exact sciences. It would have been difficult for him to say anything new on a subject with which so many distinguished thinkers have dealt; but the ideas he set forth about science and the imagination were sound and well expressed. Referring to the work of Sir William Thomson, he said: "When I think of your fellow-countryman, Sir William

Thomson, engaged on atoms and molecules, piercing the secrets of the smallest entities, brooding over the mystic dance of ethereal vortices, while his magic wand summons elemental forces to reveal the nature of their powers to his scientific gaze, I forget the disciplined accuracy of the man of science, while lost in wonder at the imaginative inspiration of the poet."

THE trustees of the Missouri Botanical Garden have issued their third announcement concerning garden pupils. The object of the trustees, as we have already stated, is to provide adequate theoretical and practical instruction for young men desirous of becoming gardeners. It is not intended at present that many persons shall be trained at the same time, nor that the instruction shall resemble exactly that given by many State Colleges, but that it shall be quite distinct, and limited to what is thought to be necessary for training practical gardeners. Three scholarships will be awarded by the Director of the Garden before April 1 next. The course extends over six years, so the trustees are particularly anxious that scholarships shall be won by boys who are not much over fourteen years of age.

THE Bulletin of the Botanical Department of Jamaica, for September, contains a report, by Mr. W. Fawcett, Director of Public Gardens and Plantations, on a disease causing the death, on a large scale, of the cocoa-nut palms in the neighbourhood of Montego Bay. The disease first attacks the tissues of the youngest parts. There is no evidence that it is produced by an insect, and Mr. Fawcett considers it is due to an "organized ferment." In the supplement of the *Jamaica Gazette* for September is the remark that the disease is "rapidly destroying the cocoa-nut walks in the parish of St. James, and that, if not checked, in a very few years the cocoa-nut will cease to be a product of this parish, indeed if not of the island."

THE Batavian Society of Arts and Sciences publishes in its Proceedings (Part 46) a list of the chief relics of the Hindu period in Java, and along with it an archeological map indicating the sites of the ruins of temples, statues, and other antiquities. Both list and map are the work of Dr. R. D. M. Verbeek, a well-known engineer.

A PAPER on water and water-supply, with special reference to the supply of London from the chalk of Hertfordshire, by Mr. John Hopkinson, appears in the Transactions of the Hertfordshire Natural History Society (vol. vi., Part 5, October 1891), and has now been published separately. Mr. Hopkinson insists that instead of more water being taken from Hertfordshire for the supply of London the amount at present taken should be reduced. London, he thinks, must sooner or later follow the example of other and much less wealthy towns by obtaining a supplementary supply from a distant source. Liverpool obtains its water from the Vyrnwy, Manchester from Thirlmere, Glasgow from Loch Katrine, and there is a project on foot for Birmingham to obtain a supply from Central Wales. The most feasible scheme for London appears to Mr. Hopkinson to be to obtain a supplementary supply from Bala Lake, or some other lake or lakes in North Wales, or from Central Wales or Dartmoor.

THE White Star liner *Teutonic*, which arrived the other day from New York, after a rapid passage, brought particulars of a collision between the Anchor Line steamer *Ethiopia* and a large whale, eight hundred miles east of Sandy Hook, on the 15th inst., on the passage to New York from Glasgow. At 10.45 a.m. Captain Wilson and Second Officer Fife were on the bridge keeping a close watch ahead. Suddenly a whale came to the surface directly in the path of the ship, and only a few feet ahead. The ship was rushing towards the whale at the rate of sixteen miles an hour. There was no time to check the speed of the vessel, and almost

before the astonished officers realized it, the ship's sharp iron prow crashed into the monster. The blow was a square, incisive one. The ship seemed to sail right through the whale, which disappeared almost immediately, leaving a trail of crimson as far as the eye could see. Shortly afterwards the whale was sighted astern, floating lifelessly. When the ship came into collision with the whale the shock caused the vessel to tremble from stem to stern, and startled the passengers for a moment. The passengers who were below rushed on deck, and a panic seemed to be imminent. Captain Wilson hurriedly left the bridge and appeared on deck. "Have no fear," he said, "we have only killed a whale. The ship is not hurt." His words allayed the fears of the passengers.

IN his recent Presidential address to the Royal Society of New South Wales, Dr. A. Leibius referred with satisfaction to the progress made by the cause of scientific and technical education in New South Wales. In addition to the opportunities given by the University of Sydney for the study of science, the Government, by the establishment of a technical college and technological museum at Sydney, with branches in different parts of the colony, have brought within the reach of all who desire it the means of acquiring scientific and technical knowledge. As an illustration of the extent to which the colony is developing this part of its educational system, Dr. Leibius mentioned that contracts already let in connection with the Sydney College alone amount to close upon £48,000, while £20,000 have been voted by Parliament for technical colleges and technological museums at Bathurst, Broken Hill, Maitland, and Newcastle.

THE Michigan Mining School, at Houghton, sends us its "Catalogue" for 1890-91. The course of instruction for the regular students at this institution extends over a period of three years, the work continuing through most of the year. The authorities of the school express an earnest desire to secure as students young men who, before beginning their professional studies, have obtained "an education of the broadest and most liberal character." Every regular student is required "to spend seven hours a day for five days each week in the laboratory or field work, or in recitation or lecture." His "recitations" are prepared "in time taken outside of the seven hours a day." On Saturdays, or on other days, as occasion may require, excursions are made to the mines, mills, and smelting-works in the neighbourhood.

At a meeting of the Pharmaceutical Society at Edinburgh on November 11, a capital address was delivered by Prof. I. Bayley Balfour, on botanical enterprise in relation to pharmacology. Prof. Balfour devoted himself especially to the task of showing how vast are the obligations of pharmacologists to the Royal Gardens, Kew. The address is printed in the current number of the *Pharmaceutical Journal*.

MR. J. E. DIXON records, in the *Victoria Naturalist* for October, a curious fact which came under his own observation. During a ramble along the Kooyong Creek, Oakleigh, on August 15, he was somewhat surprised to see a specimen of the ring-tailed opossum, hanging, as he thought, by her claws, to a sharp-pointed limb of a gum-tree, about twenty feet from the ground. Upon closer observation he found that the creature was dead, and that death was due to the fact that in her flight she had become impaled by her pouch. In the pouch were two young ones almost old enough to leave her.

MR. ANGELO HEILPRIN contributes to the *New York Nation* of November 12 an interesting paper in which he describes the charms of a summer tour to Greenland. A journey to the 75th parallel of latitude, or thereabouts, could, he says, be arranged annually with much of the certainty of a trans-

Atlantic trip, and would involve neither hardship nor danger. During the latter part of July and throughout the whole of August the coast is mainly free of ice, and even the passage of the much-dreaded Melville Bay can very generally be effected during this season of the year without danger from a "nip," and frequently with not so much as an acre of ice to interfere with the traveller's journey. Once beyond Cape York, the free North Water opens up a passage to the 79th or the 80th parallel of latitude, or to within some 700 miles of the Pole. In the course of such a trip the traveller would see much that is novel and interesting, much that is grandly picturesque, and still more that is striking in its deviation from the rest of the earth. A country inhabited by a race of people so remarkable as are the Eskimos is always worthy of a visit, especially at a time when a greatly increasing interest in the science is fostering the study of ethnology. But merely in the contemplation of the forms of the almost endless number of icebergs, the vacation tourist would probably consider himself amply repaid for a journey to this easily-reached land of the midnight sun, with its almost numberless glaciers, its sky-splitting mountains, and a boundless ice-cap. The artist, too, would find abundant suggestion for his brush and palette.

PROF. AUGUST WEISMANN'S "Amphimixis: oder, Die Vermischung der Individuen," has been published at Jena by Herr Gustav Fischer. An English translation, we believe, will shortly be issued.

A FRENCH translation—edited by Dr. H. de Varigny—of Weismann's "Essays on Heredity" (Reinwald) has been issued in Paris.

THE third volume of Dr. McCook's "American Spiders and their Spinning Work," will be ready for delivery in the coming spring. The numerous lithographic plates are many of them prepared and in the colourists' hands. The cost of preparing the numerous engravings and plates has greatly exceeded the expectations of the author (who is also the publisher).

DR. ADOLF FRITZE contributes to the *Mittheilungen der Deutschen Gesellschaft für Natur- und Völkerkunde Ostasiens, in Tokio* (Heft 46) a valuable paper on the fauna of Yezo in comparison with that of the rest of Japan. He does not, of course, profess to give a complete account of the subject; but the natural history of Yezo has hitherto been so imperfectly investigated that his work will be very welcome to zoologists.

MR. ROBERT E. C. STEARNS gives in the Proceedings of the U.S. National Museum (vol. xiv., pp. 307-335), a valuable list of shells collected on the west coast of South America, principally between latitudes  $7^{\circ}$  30' S., and  $8^{\circ}$  49' N., by Dr. W. H. Jones, Surgeon, U.S. Navy. This collection, with various other treasures, was presented to the National Museum in 1884; but until lately Mr. Stearns had not an opportunity of preparing a list. A great part of the shells were picked up on the beaches, and in poor condition; but our knowledge of the distribution of west South American species is so limited that the collection, Mr. Stearns says, has its special value for the information it furnishes on this point.

THE following science lectures will be given at the Royal Victoria Hall on Tuesday evenings during December:—December 1, "North Wales," by A. Hilliard Atteridge; 8, "The Ways in which Animals hide Themselves," by E. B. Poulton; 15, "Old Stones," by H. G. Seeley.

AT the meeting of the Chemical Society on Thursday last some further particulars were given by Mr. Mond concerning his work in conjunction with Dr. Langer upon iron carbonyl. They have succeeded in isolating two distinct compounds of iron and carbon monoxide. One of them is a liquid of the composition  $\text{Fe}(\text{CO})_5$ , to which the name ferro penta-carbonyl is

given. The other is a solid corresponding to the formula  $\text{Fe}_2(\text{CO})_7$ , and is termed di-ferro hepta-carbonyl. Liquid ferro penta-carbonyl is obtained by heating finely-divided iron, obtained by reduction of ferrous oxalate, in a stream of carbon monoxide. The operation is a very slow one, 100 grams of metallic iron yielding one gram of the liquid in twenty-four hours. Ferro penta-carbonyl is a light amber-coloured liquid, which may be distilled without decomposition. It boils constantly at  $102^{\circ}$  8 C. Its specific gravity, compared with water at  $18^{\circ}$ , is 1.44. It solidifies at  $-21^{\circ}$ , forming yellow acicular crystals. Its vapour density has been determined, the number obtained being 6.5, agreeing fairly well with the value 6.7 calculated for  $\text{Fe}(\text{CO})_5$ . The liquid is quite stable in the dark, but when exposed to light an important change occurs. Gold-coloured crystals rapidly form in it, which upon analysis are found to consist of a second iron carbonyl, the di-ferro hepta-carbonyl  $\text{Fe}_2(\text{CO})_7$ . These crystals are almost insoluble in the ordinary solvents. When warmed to  $80^{\circ}$ , however, they decompose, the products of decomposition being the penta-carbonyl metallic iron, and carbon monoxide. It appears, therefore, that iron does not exactly resemble nickel in its behaviour with carbon monoxide, for the carbonyl compound of the latter metal, it will be remembered, possesses the composition  $\text{Ni}(\text{CO})_4$ .

A NOTE upon the products of oxidation of nickel carbonyl is contributed by M. Berthelot to the current number of the *Comptes rendus*. M. Berthelot states that nickel carbonyl behaves towards oxygen in a manner somewhat similar to an organic radicle. The products of its spontaneous oxidation do not consist entirely of the oxides of nickel and carbon. The liquid may be preserved in a glass vessel under a layer of water without change so long as air is excluded; but as soon as air is admitted, the compound slowly oxidizes, and a quantity of apple-green hydrated oxide of nickel free from carbon is deposited. At the same time a portion of the nickel carbonyl volatilizes and oxidizes in the air, forming a white cloud which deposits upon all the objects in the neighbourhood. M. Berthelot has succeeded in collecting a considerable quantity of this white deposit, and has subjected it to analysis. He considers it to be the hydrate of the oxide of an organic radicle containing nickel. The numbers obtained from the analysis agree with the formula  $\text{C}_2\text{O}_3\text{Ni}_3 \cdot 10\text{H}_2\text{O}$ , but as it appears likely that the preparation contained more or less nickel hydrate this formula is not considered final. M. Berthelot is of opinion that the substance probably contains an organo-nickel compound of the composition  $\text{C}_2\text{ONi}$ , belonging to a type derived from ethylene. He is continuing the study of this interesting substance.

THE additions to the Zoological Society's Gardens during the past week include a Bonnet Monkey (*Macacus sinicus* ♀) from India, presented by Mr. J. Robinson; a Rhesus Monkey (*Macacus rhesus* ♀) from India, presented by Mrs. K. Clark-Ourry; a Macaque Monkey (*Macacus cynomolgus* ♀) from India, presented by Captain J. F. C. Hamilton; two Ourang-outangs (*Simia satyrus* ♂ ♂) from Borneo, a Greater Sulphur-crested Cockatoo (*Cacatua galerita*) from Australia, four — Pelicans (*Pelecanus* sp. inc.) from India, deposited; and a Bronze-winged Pigeon (*Phaps chalcoptera* ♂) from Australia, a Blood-breasted Pigeon (*Plaplogenas cruentata* ♀) from the Philippine Islands, purchased.

#### OUR ASTRONOMICAL COLUMN.

DETERMINATION OF THE SOLAR PARALLAX.—A. Auwers, in *Astronomische Nachrichten* (No. 3066), gives the results obtained in the determination of the solar parallax from the heliometer observations made by the German Transit of Venus Expedition, in the years 1874 and 1882. The number of measurements taken amounted to 754, of which 308 were

made from the 1874, and the remaining 446 from the 1882 transit. Taking each series of measurements of each transit separately, and applying the corrections of Leverrier's tables,

$$\begin{aligned} \text{Transit of 1874 Dec. 8} \quad \Delta\alpha &= +4^{\prime}69 \quad \Delta\delta = +2^{\prime}30 \\ \text{,, 1882 Dec. 6} \quad \Delta\alpha &= +9^{\prime}13 \quad \Delta\delta = +1^{\prime}99 \end{aligned}$$

he obtains the following values for the parallax—

$$\begin{aligned} \text{Transit of 1874} \quad \pi &= 8^{\prime}873 \\ \text{,, 1882} \quad \pi &= 8^{\prime}883 \end{aligned}$$

Both the above numbers are subject to the mean errors  $\pm 0^{\prime}062$  and  $\pm 0^{\prime}037$  respectively, and are computed in the first case from 307, and in the second from 444 measurements.

By taking now the two series together, and finding the most probable number, he obtains the following result subject to the two adjoined errors—

$$\begin{aligned} \pi &= 8^{\prime}880 \\ \text{Mean error} &= \pm 0^{\prime}032 \\ \text{Probable error} &= \pm 0^{\prime}022 \end{aligned}$$

A comparison of the above results with those of other observers, taking the transits of 1874 and 1882, may be gathered from the following list—

Transit 1874.	Transit 1882.
Harkness ... .. 8 <sup>h</sup> 888	Auwers ... .. 8 <sup>h</sup> 883
Todd ... .. 8 <sup>h</sup> 883	Cornu ... .. 8 <sup>h</sup> 86
French measures ... 8 <sup>h</sup> 88	Harkness ... .. 8 <sup>h</sup> 842
Stone ... .. 8 <sup>h</sup> 88	Faye ... .. 8 <sup>h</sup> 813
Auwers ... .. 8 <sup>h</sup> 873	Todd ... .. 8 <sup>h</sup> 803
Tupman ... .. 8 <sup>h</sup> 81	
Airy ... .. 8 <sup>h</sup> 76	

PHOTOMETRIC OBSERVATIONS.—The *Publications of the Potsdam Astro-Physical Observatory*, No. 27, contains a series of photometric measurements made by Dr. Müller at a station on the Sântis, situated 2500 metres above sea-level, with a Zöllner's photometer. The observations extend over two months, and they show that the form of the curve of extinction from the zenith to a point very near the horizon is satisfactorily represented by Laplace's Theory. But a comparison of the curves calculated separately for the various days of observation shows considerable differences, which approach and even exceed 0.4 of a magnitude near the horizon. The superiority of the Sântis station over Potsdam as regards conditions of atmospheric transparency is very striking. For a star in passing from the zenith to an altitude of about 2° has its light diminished nearly by a whole magnitude more in the plain than on the top of the mountain. From the observations, according to Laplace's Theory, the loss of light produced by the atmosphere in the zenith at Sântis is about 12 per cent.; or, in other words, a star viewed from a point above the atmosphere would appear brighter by about 0.14 of a magnitude. Since the corresponding value for Potsdam is 0.2 magnitude, it follows that the absorption produced by a stratum of atmosphere between sea-level and a height of 2500 metres amounts to 0.06 magnitude. Before this value, however, can be accepted as definite, simultaneous observations of stellar magnitudes must be made at stations lying closer together than the two between which the comparison is instituted.

THE PAMIRS.

AT the meeting of the Royal Geographical Society on Monday the paper read was on a recent journey across the Pamir by Mr. and Mrs. Littledale. In introducing the paper, Mr. Douglas Freshfield made some remarks on the subject generally.

The Pamir or Pamirs (Mr. Freshfield said)—for Pamir is a generic term, the different strips of tableland are distinguished by separate names—is a vast tableland averaging 12,000 feet in height and 200 miles in length by 120 to 150 miles in breadth, ringed by a rough horseshoe of mountain ranges, and intersected by snowy ridges and shallow trenches that deepen westwards, where the streams of the Oxus descend towards Bokhara. The numerous photographs taken by Mr. Littledale exhibit a characteristic type of landscape—tent-shaped, glacier-coated ridges, bare heights naked of verdure and shorn of forests by

the bitter winds and frosts, desolate bituminous lakes; a region where for the most part there is neither fuel nor fodder; an Engadine of Asia, with nine months winter and three months cold weather; the home of the wild sheep, the summer haunt of a few wandering shepherds; nomads' land if not no man's land. Long ago Marco Polo described it well. That is the scene of Mr. and Mrs. Littledale's adventures; that is the region where the emissaries of three nations are now setting up rival claims. "The half-way house to heaven" is a Chinese appellation for the Pamirs. "Ceruleum ipsum petimus stultitia" our and the Russian soldiers and diplomats may now almost say of one another. For the tales of summer pastures of extraordinary richness, told to Marco Polo and repeated to Mr. Littledale, refer, so far as they are true at all, only to isolated oases. The country in question cannot feed the caravans that cross it; far less could it sustain the baggage animals of an army on the march. No one in his senses could consider that in itself the Pamir is a desirable acquisition. Any value it may have is in relation to adjoining lands. From the north there is comparatively easy access to it from Russian Turkistan. From the east the Chinese and their subjects climb up the long ascent from the Khanates, and pass through easy gaps in the encircling horseshoe of mountains on to the portions of the tableland they claim. From the south, a route which seems from Mr. Littledale's experience to be anything but a military route, leads over glaciers, passes, and through well-nigh impassable gorges into Gassin and Chitral, and so to Kashmir. To the south-west easier routes, little known or little described as yet, lead into the wild regions of Kafiristan and Afghanistan. We do not here deal with politics, but we do deal with the geographical and cartographical facts on a knowledge of which politics and policy ought to be—but unfortunately for our country have not always been—based. Certain portions of the Pamir have been more or less closely attached to Afghanistan. The Amir lays claim to Wakhan, Chignan, and Koshan, tracts stretching along the sources of the Oxus. It is obvious that England will claim an interest in these, but probably, owing to the deficiencies in exact knowledge of the geographers of Cabul, we have not as yet formulated publicly our claims.

In 1873 the Russian Government, at the time of their advance to Khiva, undertook never to pass the Oxus. Shortly afterwards, Sir Henry Rawlinson argued with great force that the Murgabi, the stream that cuts the Pamirs in two, and not the Pandja, which flows along their southern skirts, was the true and proper source of the Oxus. Seven years ago, in the negotiations which followed the Penjich incident, the negotiators deliberately left this portion of the frontier out of their calculations.

Why, undeterred by the experiences of which that entertaining traveller and Anglophobe, M. Bonvalot, had lately given so alarming a picture, should an Englishman and his wife cross this desert? Mr. and Mrs. Littledale are eager in the pursuit of rare game. They were old travellers; they had sojourned in the forest wildernesses of the western Caucasus; they had, on a previous occasion, penetrated Central Asia. A pair of horns were to them what a bit of rock from a maiden peak is to others.

And lastly, why did Mr. and Mrs. Littledale go from north to south? Why did they, being English, make Russian territory their starting-point? Thereby hangs a tale. Because our Anglo-Indian Government prohibits all independent travel in its trans-frontier lands. Something may be said for this course, but it does not stop there. It also gags its own official explorers. It carries yearly farther and farther the policy deprecated by Sir H. Rawlinson in this hall, when he said: "Russia deserves all honour for her services to geographical science in Asia. I only wish I could say as much for ourselves as regards our own frontiers."

No one, least of all the Council of this Society, would ask for the publication of any tactical information our military authorities desired to withhold. But the military authorities go along with us in asking for an intelligent censorship in place of a wholesale system of suppression of the mass of knowledge, general and scientific, acquired by the servants of the State in our frontier and trans-frontier lands. We believe, and the Council have represented to H. M. Government, that the present practice is not in accordance with the existing official rules, that it was intended and has been ordered that expurgated copies of all official reports of public interest should be given to the public. They hope that the departments concerned will before

long be instructed to give practical effect henceforth to any such instructions that may exist, and thus that the forward march of English power may once more, as it should, be accompanied by a general advance of scientific knowledge.

Leaving Samarcand early in May, Mr. and Mrs. Littledale drove in Russian post-carts up the beautiful valley of the Syr-Daria, which reminded them in parts of the Vale of Kashmir, as far as Osh, the last post-station. Here they organized their caravan for their great adventure, the crossing of the Pamirs into Kashmir. They had the advantage of previous experience of Central Asian travel, and of the cordial assistance of the Russian Commandant, Colonel Deubner, who could hardly have done more for the travellers had they been his own nearest relatives. After much hesitation from the difficulty of obtaining any trustworthy information as to the state of the Alai passes, they selected the Taldik, 11,600 feet, before crossing which, they left behind the last tree and bush they were to see until reaching the valley of the Gilgit.

Crossing the Alai plateau they proceeded by the Kizil Art Pass to Karakul Lake. Thence their route led over passes of 15,500 feet, in sight of the great Mustag Atta to the Murgab or North Oxus, which they struck at 12,300 feet, their correct elevation between the Alai and Sarbad. Another pass of 14,200 feet led over the Alichur Pamir—where *Ovis poli* horns lie about in hundreds—to the Boshgumbaz Valley. The pass of the same name was found impracticable. Mr. and Mrs. Littledale made a long detour to visit the Victoria Lake, one of the sources of the South Oxus, for purposes of sport. Thence they turned eastwards and crossed by the Little Pamir Lake into the Valley of Wakhan. When near Sardab they met with their first misadventure, and this was the encounter with the troops of our ally the Ameer. The civil authorities detained Mr. and Mrs. Littledale for many days, and only let them go at last grudgingly, and after having despoiled them as far as they could without open robbery.

#### ELIZABETH THOMPSON SCIENCE FUND.

THIS fund, which has been established by Mrs. Elizabeth Thompson, of Stamford, Connecticut, "for the advancement and prosecution of scientific research in its broadest sense," now amounts to \$26,000. As accumulated income will be available in December next, the trustees desire to receive applications for appropriations in aid of scientific work. This endowment is not for the benefit of any one department of science, but it is the intention of the trustees to give the preference to those investigations which cannot otherwise be provided for, which have for their object the advancement of human knowledge or the benefit of mankind in general, rather than to researches directed to the solution of questions of merely local importance.

Applications for assistance from this fund, in order to receive consideration, must be accompanied by full information, especially in regard to the following points:—

- (1) Precise amount required. Applicants are reminded that one dollar (\$1.00 or \$1) is approximately equivalent to four English shillings, four German marks, five French francs, or five Italian lire.
- (2) Exact nature of the investigation proposed.
- (3) Conditions under which the research is to be prosecuted.
- (4) Manner in which the appropriation asked for is to be expended.

All applications should reach, before December 10, 1891, the Secretary of the Board of Trustees, Dr. C. S. Minot, Harvard Medical School, Boston, Mass., U.S.A.

It is intended to make new grants at the end of 1891.

\* The trustees are disinclined, for the present, to make any grant exceeding three hundred dollars (\$300); decided preference will be given to applications for smaller amounts.

(Signed) HENRY P. BOWDITCH, President.  
WILLIAM MINOT, JR., Treasurer.  
EDWARD C. PICKERING.  
FRANCIS A. WALKER.  
CHARLES-SEDGWICK MINOT, Secretary.

#### List of Grants hitherto made.<sup>1</sup>

1. \$200, to the New England Meteorological Society, for the investigation of cyclonic movements in New England. [*American Meteorological Journal* for 1887, and May 1888.]

<sup>1</sup> The results published are given within brackets.

2. \$150, to Samuel Rideal, Esq., of University College, London, England, for investigations on the absorption of heat by odorous gases.
3. \$75, to H. M. Howe, Esq., of Boston, Mass., for the investigation of fusible slags of copper and lead smelting. [*Trans. Amer. Institute of Mining Engineers*, Feb., 1890.]
4. \$500, to Prof. J. Rosenthal, of Erlangen, Germany, for investigations on animal heat in health and disease. [*Sitzungsber. K. Akad. Wiss.*, 1888, 1309-1319; 1889, 245-254. *Arch. Anat. u. Physiol.*, Suppl. 1888, 1-53.]
5. \$50, to Joseph Jastrow, Esq., of the Johns Hopkins University, Baltimore, Md., for investigations on the laws of psycho-physics. [*American Journal Psychology*, 1890, III., 43-58.]
6. \$200, to the Natural History Society of Montreal, for the investigation of underground temperatures. [*Canadian Record of Science*.]
7. \$210, to Messrs. T. Elster and H. Geitel, of Wolfenbüttel, Germany, for researches on the electrization of gases by glowing bodies. [*Sitzungsber. K. Akad. Wiss. Wien*, xcvi., Abth. ii., 1175-1264, 1889.]
8. \$500, to Prof. E. D. Cope, of Philadelphia, Penn., to assist in the preparation of his monograph on American fossil vertebrates.
9. (Withdrawn.)
10. \$125, to Edw. E. Prince, Esq., of St. Andrews, Scotland, for researches on the development and morphology of the limbs of Teleosts. ["Inaugural Dissertation," Pp. 24, Pls. II., Glasgow, 1891.]
11. \$250, to Herbert Tomlinson, Esq., of University College, England, for researches on the effects of stress and strain on the physical properties of matter. [*Philos. Magazine*, Jan., 1890, 77-83.]
12. \$200, to Prof. Luigi Palmieri, of Naples, Italy, for the construction of an apparatus to be used in researches on atmospheric electricity.
13. \$200, to Wm. H. Edwards, Esq., of Coalburg, W. Va., to assist the publication of his work on the butterflies of North America. ["Butterflies of North America," 3rd Series, Part V.]
14. \$150, to the New England Meteorological Society, for the investigation of cyclonic phenomena in New England.
15. \$25, to Prof. A. F. Marion, for researches on the fauna of brackish waters.
16. \$300, to Prof. Carl Ludwig, for researches on muscular contraction, to be carried on under his direction by Dr. Paul Starke. [*Abhandl. math. phys. Classe K. sächs. Ges. Wiss.*, xvi., 1890, 1-146, Taf. i.-ix.]
17. \$200, to Dr. Paul C. Freer, for the investigation of the chemical constitution of graphitic acid.
18. \$300, to Dr. G. Müller, for experiments on the resorption of light by the earth's atmosphere. [*Publicationen Astrophys. Observ. Potsdam.*, viii., 1-101, Taf'n II.]
19. \$300, to Prof. Gerhard Krüss, for the investigation of the elementary constitution of erbium and didymium. [*Liebig's Annalen*, Bd. 265, 1-27.]
20. \$50, to Dr. F. L. Hoorweg, for the investigation of the manner and velocity with which magnetism is propagated along an iron bar.
21. \$150, to Mr. W. H. Edwards, to assist the publication of his work on North American butterflies. ["Butterflies of North America," 3rd Series, Part VIII.]
22. \$250, to Dr. Ernst Hartwig, for researches on the physical libration of the moon (see Grant No. 27).
23. \$200, to Prof. Charles Julin, for researches on the morphology of Ascidians.
24. \$250, to Prof. M. Nencki, for researches on the decomposition of albumenoids by microbes. [*Arch. Expt. Path. Pharmacol.*, xxviii., 311-350, Taf. IV.-V.]
25. \$200, to Prof. Carl Frommann, for researches on the minute organization of cells.
26. \$300, to Edward Atkinson, Esq., for experiments on cooking, to be carried on under the direction of Mrs. Ellen H. Richards. [*Proc. Amer. Assoc. Adv. Sci.*, 1890.]
27. \$250, to Dr. Ernst Hartwig, to continue the work of Grant No. 22.

28. \$200, to Edward S. Holden, Esq., for researches on stellar spectroscopy, to be carried on at the Lick Observatory.
29. \$150, to Prof. J. Kollmann, for investigations on the embryology of monkeys.
30. \$25, to Prof. J. P. McMurrich, Clark University, Worcester, Mass., to study embryology of Aurelia.
31. \$200, to Dr. Johannes Dewitz, Zoolog. Institute, Berlin, Germany, for researches on the laws of movement of Spermatozoa.
32. \$150, to Alexander McAdie, Clark University, Worcester, Mass., for experiments on atmospheric electricity.
33. \$250, to Prof. Julien Fraipont, University of Liège, Liège, Belgium, for the exploration of the cave of Enghoul.
34. \$50, to Prof. M. E. Wadsworth, Houghton, Michigan, for observations on the temperature in mining-shafts.
35. \$50, to Prof. A. B. Macallum, University of Toronto, Toronto, Canada, to study the digestion and absorption of chromatin.
36. \$250, to Dr. G. Baur, Clark University, Worcester, Mass., for the exploration of the Galapagos Islands.
37. \$300, to Prof. Edw. S. Holden, Lick Observatory, Cal., for astronomical photography.
38. \$250, to Prof. Louis Henry, Louvain, Belgium, for researches on the fundamental solidarity of carbon compounds.
39. \$300, to Prof. L. Hermann, Königsberg, Prussia, for photographic experiments on vowels.
40. \$50, to Prof. Alpheus Hyatt, Cambridge, Mass., for researches on the evolution of Cephalopoda.

#### UNIVERSITY AND EDUCATIONAL INTELLIGENCE.

OXFORD.—Convocation on Tuesday arrived at the following decision:—

"That the University accept the offer of Mr. G. J. Romanes, F.R.S., Christ Church, to give an annual sum of £25 for a lecture to be delivered once a year on some subject approved by the Vice-Chancellor relating to science, art, or literature. The lecturer to be called the Romanes Lecturer, and to be appointed by the Vice-Chancellor annually in the Michaelmas Term, the lecture to be delivered in the next following Easter or Trinity Term on a day to be fixed by the Vice-Chancellor, who shall give public notice thereof to the University in the usual manner. Also, that the thanks of the House be given to Mr. Romanes for his liberality."

We understand it was Mr. Romanes's wish that the foundation should be anonymous; but as such a course was found to be without precedent, and otherwise impracticable, he yielded the point to the University authorities.

Mr. H. T. Gerrans, Fellow of Worcester College, has been elected by the Board of the Faculty of Natural Science a member of the Committee for nominating Masters of the Schools from Hilary Term 1892 to Hilary Term 1895. Mr. C. H. Sampson, Fellow of Brasenose College, has been elected by the same Board of Faculty a member of the Committee for nominating Mathematical Honour Moderators.

#### SCIENTIFIC SERIALS.

A GOOD deal of interesting geological information is given in the last number of the *Izvestia* of the East-Siberian Branch of the Russian Geographical Society (vol. xxii., 2 and 3). M. Obrutcheff gives an orographical and geological sketch of the highlands of the Olekma and the Vitim, with the exploration of which he was intrusted by the mining administration. Besides the upheavals of these highlands, which have a general direction from the south-west to the north-east, M. Obrutcheff found another series of upheavals stretching west-north-west to east-south-east, the chief ridge of that system (named Kropotkin's ridge by the author) rising to the height of from 1300 to 1500 metres, and separating the tributaries of the Lena from those of the Vitim. Several lower chains seem to have the same direction. The whole series consists of metamorphic slates and limestones, intersected by granites and gneisses, and belongs to the Lower Silurian and Cambrian system, a closer definition of its age being difficult

on account of a total want of fossils. M. Obrutcheff also confirms the glaciation of the whole of these highlands. The valleys are filled up with morainic deposits, with polished and striated boulders, and there are traces of inter-glacial layers. The *dômes arrondis* and the *roches moutonnées*, so familiar to the glacialist, are frequent, and the author gives interesting facts to confirm the transport of boulders at great distances over the mountain-ridges, which cannot be explained without admitting that the whole of the highlands was covered with a mighty ice-cap. The same number contains a note by the same author on the Jurassic fossil plants recently discovered on the Bureya River (a tributary of the Amur), and a list of 290 flowering plants collected by Mme. Klements in South Yeniseisk and Tomsk, and described by M. Preyn.

#### SOCIETIES AND ACADEMIES.

LONDON.

Chemical Society, November 5.—Mr. W. Crookes, F.R.S., Vice-President, in the chair.—The following papers were read:—The magnetic rotatory power of solutions of ammonium and sodium salts of some of the fatty acids, by Dr. W. H. Perkin, F.R.S. Ostwald has argued that the peculiar results obtained by the author in the case of solutions of acids and of ammonium salts, &c., are in accordance with the electrolytic dissociation hypothesis; and has suggested that since salts formed from weak acids are as good conductors as those formed from strong ones, we may expect in this case also, marked deviations from the calculated values. He also considers that such salts as ammonium formate, &c., when in aqueous solution would show molecular rotations which would not be the sums of the rotations of the components of the salts, as must nearly be the case if the view put forward by the author be correct, that such salts are almost entirely dissociated into acid and base. The author has obtained results which show that the rotatory powers of the ammonium and sodium salts do not vary with dilution; and on comparing the experimental values obtained in the case of ammonium salts with those afforded by the constituent acid and ammonia, as might be expected, as reduction of rotatory power always attends combination, the values are slightly less in the case of the salts. This reduction is very nearly the same as that which takes place in the formation of the corresponding ethereal salts, and as the latter are anhydrous, the results show that the values for ammonium salts in solution are practically those of the dry salts, and therefore that Ostwald's views are inapplicable.—Note on the action of water gas on iron, by Sir H. E. Roscoe and F. Scudder. Whilst making experiments on the application of water gas for illuminating purposes, the authors have observed that occasionally the *Fahnehjelm* comb becomes coated with a deposit of ferric oxide, and a further examination of the tips of the steatite burners showed that the deposit of ferric oxide was "coralloid," and therefore could not be produced from dust in the atmosphere. They also observe that water gas which has been standing in steel cylinders at a pressure of 8 atmospheres for about a month contains a much larger quantity of iron. A preliminary determination of the iron in this gas amounted to 2.4 milligrams per litre. Although the compound, which is doubtless the iron carbonyl of Mond and Quincke, is only present in this small quantity, the authors have succeeded in proving that it can readily be liquefied. In the discussion which followed, the Chairman referred to the fact that at the recent British Association meeting at Cardiff, Mr. Mond had exhibited specimens not only of liquid iron carbonyl, but also of a solid compound of iron with carbonic oxide. Prof. Ramsay stated that he had found that the compound of nickel with carbonic oxide was formed in the cold.—The dissociation of liquid nitrogen peroxide, by J. Tudor Cundale. The author has determined by colorimetric methods the relative amount of  $\text{NO}_2$  formed in liquid nitrogen peroxide, (1) by dilution with chloroform, (2) by rise of temperature. He has also ascertained the absolute amounts of dioxide by comparing the colour of the liquid solution with that of the gas containing a known amount of nitrogen peroxide. The results show that, on dilution, (1) dissociation takes place very slowly at first, but more rapidly when less than 5 per cent. of the peroxide is present; (2) that solutions of the peroxide dissociate more rapidly than the pure liquid on rise of temperature.—Ortho- and para-nitro-ortho-toluidine, by A. G. Green and Dr. T. A. Lawson. The authors find that when ortho-toluidine sulphate is nitrated in a large

excess of sulphuric acid at a low temperature, three isomerides are formed—namely, *para*-nitro-ortho-toluidine (about 75 per cent.), *meta*-nitro-ortho-toluidine,  $C_6H_4Me(NH_2)(NO_2)[1:2:5]$  (about 3 and 4 per cent.), and *ortho*-nitro-ortho-toluidine,  $C_6H_3Me(NH_2)(NO_2)[1:2:6]$  (about 20 per cent.). The separation of the ortho-nitro-ortho-toluidine from the mixture is effected by taking advantage of the greater solubility of this isomeride in slightly warm water. The authors give a table of the properties of the ortho- and para-nitro-ortho-toluidines, and of their products on reduction and other derivatives.—Researches on the gums of the arabin group: Part II. Geddic acids—Gedda gums; the dextro-rotatory varieties, by C. O'Sullivan. The Gedda gums described consist of the calcium, magnesium, and potassium salts of gum acids, the calcium salt predominating, and more or less nitrogenous matter, which is probably combined with a true gum acid. They dissolve easily in water, forming a yellow or reddish syrup, neutral to test-paper, which is dextro-rotatory. The gum acids are obtained pure by dialyzing their acidified solution, and by fractional precipitation with alcohol. The gum acids in any one sample of gum bear a very simple relation to one another, and are closely related to the gum acids contained in other samples. A table of their relationships is given. The composition and partial constitution of any one of the gum acids which have been as yet examined may be expressed by the general formula,  $C_{23}H_{38-2n}O_{22-7n}nC_{10}H_{16}O_{10}pC_{10}H_{16}O_{10}$ . These gum acids, when heated at 80°-100° for 10-30 minutes with a solution containing 2 per cent.  $H_2SO_4$ , are hydrolyzed, yielding arabinon and a gum acid of lower molecular weight. The gum acids thus produced closely resemble the gum acids existing in the natural gums, but are less optically active and more insoluble in weak alcohol. The most marked difference between these gum acids and those existing in the natural gums is that they are only hydrolyzed with difficulty with 2 per cent. sulphuric acid. They are, however, slowly broken down by several hours' digestion, and acids of successively lower weight are formed. The lowest stage of the hydrolysis is represented by the general equation:—

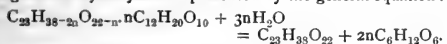

The compound  $C_{23}H_{38}O_{22}$  has not yet been obtained in sufficient quantity for an examination of its properties. Those gum acids obtained from Gedda gum are highly dextro-rotatory, whilst those from gum arabic, although otherwise identical, are inactive.—Some compounds of the oxides of silver and lead, by Emily Aston. The author finds that on following the directions given by Wöhler for the preparation of the compound  $Ag_2O, 2PbO$  the product varies in composition. A substance of the composition  $2Ag_2O, PbO$  is obtained when a mixture of lead and silver hydroxides is allowed to stand in presence of caustic soda, and also by precipitating the mixed nitrates of lead and silver, and exhaustively extracting with caustic soda.—The electrolysis of potassium acetate solutions, by Dr. T. S. Murray. On electrolyzing a dilute aqueous solution of potassium acetate only hydrogen and oxygen are evolved; with concentrated solutions a mixture of ethane, hydrogen, oxygen, methyl acetate, and carbon dioxide is evolved. On diluting the solution the amount of ethane decreases, at first very slowly, but finally with great rapidity. Reducing the current has a similar influence. With rise in temperature, the ethane diminishes, and ceases to be formed at 100°. In contradiction to Jahn, the author finds that the employment of a large anode reduces the yield of ethane; the largest yield is obtained with a very small anode; variations in the cathode do not influence the electrolysis. The results of the experiments are illustrated by curves. The author believes that the ethane is formed, not by partial oxidation of acetic acid, but by a simple interaction of the acetions ( $CH_3COO$ ). He finds that the yields of ethane from equivalent solutions of potassium, sodium, and calcium acetates are equal.—A new method of preparing  $\beta$ -dinaphthalene oxide, and the constitution of its tetra-sulphonic acid, by W. R. Hodgkinson and L. Limpach. Beta-dinaphthalene oxide is obtained by heating 2:3  $\beta$ -naphthol-sulphonic acid to low redness; the distillate is freed from  $\beta$ -naphthol by extraction with alkali, and the residue crystallized from acetic acid. It crystallizes in rhombic plates, and melts at 153°. On sulphonation it yields a tetra-sulphonic acid, which is identical with the product obtained by the continued action of sulphuric acid on  $\beta$ -naphthol.

Linnean Society, November 5.—Prof. Stewart, President, in the chair.—On behalf of a number of subscribers, Mr.

Carruthers presented to the Society a half-length portrait in oils of Sir John Lubbock, Bart., M.P., P.C., F.R.S., a former President, painted by Mr. Leslie Ward; and the remarks which he made on the services rendered to biological science by Sir John Lubbock drew from the latter a graceful acknowledgment of the honour conferred upon him.—Amongst the exhibitions which followed, Mr. E. M. Holmes showed some new marine Algæ from the Ayrshire coast; Mr. J. G. Grenfell showed some Diatoms with pseudopodia, illustrating his remarks with diagrams, upon which an interesting discussion followed.—The President exhibited and made some observations on a tooth of the walrus, which illustrated in a curious manner the periods of growth.—Mr. R. V. Sherring called attention to a large series of framed photographs which had been taken under his direction in Grenada, and illustrated the general character of the West Indian flora as well as the physical features of that particular island.—Mr. J. E. Harting exhibited a specimen of Wilson's Petrel which had been picked up in an exhausted state in the Co. Down on October 2 last, and had been forwarded for inspection by Mr. R. Patterson, of Belfast. Mr. Harting gave some account of the species, and remarked upon the unusual number of Petrels, Shearwaters, Skuas, and other marine birds which had been driven inland to a considerable distance during the recent gales.—A paper was then read by the Rev. Prof. Henslow, entitled "A Theory of Heredity based on Forces instead of any special form of Matter." The author maintained that no special form of matter (as is generally supposed) other than protoplasm is required; the latest discoveries of the organized structure of protoplasm militating against the idea of any other special form of matter. Taking illustrations from the animal and vegetable kingdoms, he inquired why two varieties of chickens fed from the first day to full growth were different? It seemed to him more probable that the results were due to different arrangements of the same kinds of molecules rather than to different kinds of "germ-plasm." *Ranunculus heterophyllis*, he pointed out, produced a "land-form" and a "water-form" according to its environment; it therefore exhibited both "heredity" and "acquired characters." As the materials of its structure were the same in both cases, the different results, he considered, must be due to different arrangements of its molecules, and must be effected by forces. The sudden appearance of stomata on the "land-form" illustrated a case of forces normally "potential" while the leaf is submerged, becoming "actual" when the leaf developed in air. After some further deductions, Prof. Henslow concluded that protoplasm and the forces bound up with it were perfectly able to do all the work of transmitting parental characters, as well as to acquire new characters, which in turn might become hereditary as well.

Physical Society, November 6.—Dr. E. Atkinson, Vice-President, in the chair.—Prof. Sydney Young read a paper on the generalizations of Van der Waals regarding "corresponding" temperatures, pressures, and volumes, in which he gave the results of an investigation made with a view of testing whether these theoretical deductions agree with experimental facts. From his virial equation,

$$\left(\rho + \frac{a}{v^2}\right)(v - b) = R(t + \alpha),$$

Van der Waals showed that, if the absolute temperatures of various substances be proportional to their absolute critical temperatures, their vapour pressures will be proportional to their critical pressures, and their volumes, both as liquid and as saturated vapour, will be proportional to their critical volumes. These deductions have now been put to the test of experiment. Some years ago, Prof. Ramsay and the author published data relating to the temperatures, pressures, and specific volumes of methyl-, ethyl-, and propyl-alcohols, ether, and acetic acid. Since then, experiments have been made on benzene and its halogen derivatives—fluor-, chloro-, bromo-, and iodo-benzene—carbon tetrachloride and stannic chloride, and in a few cases the observations have been carried to the critical points. The critical volumes being in many cases difficult to determine with any exactness, the author, instead of expressing the temperatures, pressures, and volumes of each substance in terms of their critical values, found it necessary to compare the various substances with one of them taken as a standard. Fluorobenzene was chosen as standard on account of the very simple relations observed between the monohalogen derivatives of benzene, and the fact of its critical constants (temperature, pressure, and

volume) having been determined with considerable accuracy. Some of the critical constants of the various substances examined are given in the following table, the brackets indicating calculated values—

Substance.	Formula.	Temperatures in °C.	Pressures in mms. of mercury.	Volumes in c.c.'s of a gramme molecular.	
Fluorbenzene ...	$C_6H_5F$	286.55	33,912	2.43	233
Chlorobenzene ...	$C_6H_5Cl$	(360)	(33,912)	2.34	(262)
Bromobenzene ...	$C_6H_5Br$	(397)	(33,912)	1.76	(275)
Iodobenzene ...	$C_6H_5I$	(448)	(33,912)	1.47	(298)
Benzene ...	$C_6H_6$	288.5	36,395	2.82	219
Carbon tetrachloride	$CCl_4$	283.15	34,180		
Stannic chloride ...	$SnCl_4$	318.7	28,080		
Ether ...	$(C_2H_5)_2O$	194.4	27,060		
Methyl alcohol ...	$CH_3OH$	240.0	59,760		
Ethyl alcohol ...	$C_2H_5OH$	243.1	47,850		
Propyl alcohol ...	$C_3H_7OH$	263.7	38,120		
Acetic acid ...	$CH_3COOH$	321.6	43,400	2.46	147

Other tables of experimental data—including boiling-points at corresponding pressures, vapour pressures at corresponding temperatures, molecular volumes of liquid and saturated vapours at corresponding pressures and at corresponding temperatures, and ratios calculated therefrom, accompany the paper. From these the author infers: (1) that Van der Waals's generalizations are nearly true for chloro-, bromo-, and iodobenzene when compared with fluorbenzene; (2) that for benzene, carbon tetrachloride, stannic chloride, and ether, the generalizations may only be taken as rough approximations to the truth; and (3) that for the three alcohols and acetic acid, they do not hold good at all. The tables further show that more consistent results are obtained when the comparisons are made at corresponding pressures rather than at corresponding temperatures, particularly in the case of molecular volumes of saturated vapours. The subject of saturated vapours is also treated by another method. If Van der Waals's deductions were strictly true, then the ratios of the actual densities of the saturated vapours of different substances to their theoretical densities should be equal at corresponding pressures. These ratios have therefore been calculated, and show an approximate agreement amongst benzene and its halogen derivatives, carbon tetrachloride, stannic chloride, and ether. For the other substances the agreement is less satisfactory. It is also noted that the ratio of the actual critical density to the theoretical density is for many substances about 4.4. The alcohols differing so widely from the other compounds, were compared amongst themselves instead of with fluorbenzene, with the result that somewhat closer agreement was found, but the deviations were still far outside the limits of experimental error. Of the critical constants the volumes are the most difficult to determine, because at the critical point the curves connecting temperature and volume, and pressure and volume, are parallel to the axes of volume. Accordingly, the author, in some cases, has deduced this quantity by plotting against temperature the numbers representing the ratios of the molecular volumes both of liquid and saturated vapour to those of fluorbenzene at corresponding temperatures and also at corresponding pressures. Four curves result, which should intersect at the critical temperature, and the point of intersection gives the ratio of the molecular critical volume of the substance to that of fluorbenzene. This method leads to results in fair accord with direct determinations. In the discussion which followed the reading of the paper, Prof. Ramsay said the results proved that Van der Waals's generalizations were only rough approximations, and he suggested that some force had been neglected or a term omitted from the equations. Perhaps the assumption that the molecules are incompressible was not correct. He also strongly protested against the tacit assumption of Van der Waals's laws, and deductions made therefrom, which had recently become so common, particularly in German text-books. Prof. Perry inquired whether the quantities  $a$ ,  $b$ , and  $c$ , had been determined for different substances and found to be constant. Prof. Ramsay said that for substances in states analogous to those of perfect gases, the quantities were approximately constant, but when the liquid state was approached this was no longer

true. According to Prof. Tait, the two states were not continuous. Prof. Herschel remarked that Prof. Tait had established his law on the assumption that the co-volume is four times the volume occupied by the molecules. This law, he said, had been amply verified by experiments on explosions. Dr. Burton, referring to Prof. Ramsay's remarks on the compressibility of molecules, said the law of force between attracting molecules should be accurately known before any deductions were made; and he pointed out that, at constant volume, the pressure should be proportional to the absolute temperature, if allowance be made for the negative pressure of attraction. Mr. Blakesley, in speaking of molecular forces, said he had observed that, when water is allowed to evaporate from glass, a furrow is formed in the glass, which marks out the original boundary of the liquid. To all appearance, the particles of glass are torn away by the molecular forces acting along the boundary.

**Geological Society, Nov. 11.**—Sir Archibald Geikie, F.R.S., President, in the chair.—The following communications were read:—On *Dacrytherium ovium* from the Isle of Wight and Quercy, by R. Lydekker. The author described a cranium and mandible of *Dacrytherium Cayluxi* from the Quercy phosphorites, which proved the identity of this form with the *Dichobune ovina* of Owen from the Oligocene of the Isle of Wight. This species should thus be known as *Dacrytherium ovium*. It was shown that the mandible referred by Filhol to *D. Cayluxi* belongs to another animal.—A discussion followed, in which Mr. Charlesworth and Mr. E. T. Newton took part.—Supplementary remarks on Glen Roy, by T. F. Jamieson. The author discusses the conditions that preceded the formation of the Glen Roy Lake, and appeals to a rain-map of Scotland in support of his contention that the main snowfall in glacial times would be on the western mountains. He gives reasons for supposing that, previously to the formation of the lake, the valleys of the Lochaber lakes were occupied by ice, and that the period of the formation of the lakes was that of the decay of the last ice-sheet. He supports the correctness of the mapping of the terraces by the officers of the Ordnance Survey, and shows how the absence of the two upper terraces in Glen Spean and of the highest terrace in Glen Glaster simplifies the explanation of the formation of the lakes by ice-barriers. The alluvium of Bobuntine is considered to be the gravel and mud that fell into the lake from the front of the ice when it stood at the mouth of Glen Roy during the formation of the two upper lines. During the last stage of the lake, the ice in the valley of the Caledonian Canal is believed to have constituted the main barrier, whilst the Corry N'Eoin glacier played only a subordinate part. The author suggests the possibility of a *debâcle* during the drop of water from the level of the highest to that of the middle terrace, and in support of this calls attention to the breaking down of the moraines of the Treig glacier at the mouth of the Rough Burn. He believes that when the water dropped to the level of the lowest terrace, it drained away quietly, at any rate until it receded from Upper Glen Roy. In discussing Nicol's objections, he maintains that notches would not be cut at the level of the *cols*, and observes that the discrepancy between the heights of the terraces and those of the *cols* has probably been increased by the growth of peat over most of the ground about the watersheds. The horizontality of the terraces is stated to be a fact, and cases are given where waterworn pebbles are found in connection with the "roads," these being especially noticeable in places where the south-west winds would fully exert their influence, and the structure of the terraces is considered to be such as would be produced at the margins of ice-dammed lakes. Further information is supplied concerning the distribution of the boulders of Glen Spean syenite. These are found on the north side of the Spean Valley, at the height of 2000 feet above the sea and 1400 feet above the river, and fragments of the syenite have been carried towards the north-east, north, and north-west. In an appendix, the author discusses Prof. Prestwich's remarks on the deltas, and his theory of the formation of the terraces. After some remarks from Prof. Bonney and Mr. Marr, the President said he agreed that no explanation that had yet been proposed for the parallel roads of Lochaber was free from difficulties. Yet he had long felt that these were far fewer and less formidable in the glacier theory than in any other. Had the terraces been marine, there ought surely to be similar terraces in some at least of the hundreds of sheltered glens in the Scottish Highlands, where the conditions for their formation and preservation were at least as favourable as in Glen Roy and its adjacent valleys. And though the absence of marine shells



in the Lochaber shales might not be a serious difficulty, it was hard to understand why such shells should not be found in many localities had the whole country been submerged to the height of the highest Glen Roy "road." Then no satisfactory explanation on the marine theory had ever been given of the coincidence of the terraces with well-marked *cols*; while a further formidable objection to this theory lay in the nature and distribution of the detritus of the shales, which, in his opinion, was very unlike material arranged in a tidal sea, but was quite what might be looked for in a freshwater lake. He thought that the author's present paper lessened some of the difficulties of the glacier theory by simplifying the grouping of the ice-dams. There still remained the objection that if the Great Glen and the valleys round Ben Nevis were choked up with ice, Glen Roy and its neighbours could hardly have been filled with water. But this difficulty, which every glacialist must have felt, was probably more formidable in appearance than in reality. As Mr. Marr had pointed out, conditions did actually now exist in Greenland very similar to those which, according to the theory so ably expounded by the author, formerly existed in Lochaber.

**Royal Meteorological Society, November 18.**—Mr. Baldwin Latham, President, in the chair.—Mr. R. H. Scott, F.R.S., gave an account of the proceedings of the International Meteorological Conference, which was held at Munich from August 26 to September 2.—The following papers were also read:—Account of an electric self-recording rain-gauge, by Mr. W. J. E. Binnie. This is a very ingenious instrument, and has been constructed on the assumption that all drops falling from an orifice or tube are identical in weight, as long as the dimensions of the orifice are not varied.—On wet and dry bulb formulae, by Prof. J. D. Everett, F.R.S. This is a criticism of the methods investigated some years ago by M. August and Dr. Apjohn for determining, by calculation, the maximum vapour tension for the dew point from the temperatures of the dry and wet bulb. Prof. Everett also criticizes the values adopted by Regnault, and says that, in presence of the uncertainties as to a rational formula, he thinks Mr. Glaisher did wisely in constructing his table of factors, which give the dew point approximately by the most direct calculation which is admissible. The inherent difficulties of hygrometric observation and deduction are great, and have not yet been fully overcome.—Results of meteorological observations made at Akassa, Niger Territories, May 1889 to December 1890, by Mr. F. Russell, F.R.G.S. This is in continuation of a former communication respecting the same place. After detailing the results of the various observations, the author says that this period was very unhealthy, and the year 1890 especially so. The weather was exceptionally dry, with small-pox and phthisis amongst the native population. The West Coast reports generally were also unfavourable in reference to the condition of resident Europeans, and at the principal ports quarantine regulations were put in force consequent upon an outbreak of yellow fever in places situated to the south-west. At Bonny ten deaths occurred from November to February out of a population of some sixteen Europeans.

## SYDNEY.

**Royal Society of New South Wales, September 2.**—H. C. Russell, F.R.S., President, in the chair.—The following papers were read:—On a wave-propelled vessel, by Lawrence Hargrave.—Notes on a spontaneous disease among Australian rabbits, by M. Adrien Loir.—Notes on recent celestial photographs, by H. C. Russell, F.R.S.—Some folk-songs and myths from Samoa, by Rev. G. Pratt and Dr. John Fraser.—A quick filter without the aid of pumps was exhibited and described by W. M. Hamlet.

October 7.—H. C. Russell, F.R.S., President, in the chair.—The following papers were read:—Notes on the use, construction, and cost of service reservoirs, by C. W. Darley.—Dr. Fraser presented some myths and historical records from Samoa. The myths had reference to an ancient practice of offering every day a human sacrifice to the sun, and to a chief called "Malietoa the Fierce," and showed how that was stopped. The histories were chiefly genealogies of the kings of Manu'a.

## PARIS.

**Academy of Sciences, November 16.**—M. Duchartre in the chair.—On the secular acceleration of the moon and the variability of the sidereal day, by M. F. Tisserand. From the author's

investigation it seems that the increase in the length of the day produced by tidal action is almost the same in amount as the decrease resulting from the secular contraction of the earth due to its cooling, so the length of the sidereal day remains practically invariable.—On the research on the number of roots common to several simultaneous equations, by M. Emile Picard.—On the law of intensity of light emitted by phosphorescent bodies, by M. Henri Becquerel. A correction to a formula given in a previous paper.—The heat of formation of hydrazine and of hydrazoic acid, by MM. Berthelot and Matignon. *Hydrazine*—(1) Heat of solution of hydrazine sulphate at 10°·6 is - 8·70 cal. per molecule. (2) Heat of neutralization: (a) by sulphuric acid + 5·55 cal. per equivalent; (b) by hydrochloric acid + 5·2 cal. per equivalent. Hydrazine is therefore a weak base comparable to ferric oxide. (3) Heat of combustion of 1 mol. crystallized hydrazine sulphate = + 127·7 cal. (4) Heat of formation  $\frac{1}{2}$ N<sub>2</sub>H<sub>4</sub> = - 4·75 cal. *Hydrazoic acid*—(1) Heat of solution of ammonium salt, = - 7·08 cal. per mol. (2) Heat of neutralization: (a) by baryta water + 10·0 cal.; (b) by ammonia + 8·2 cal. Hydrazoic acid, dilute, is comparable to amidobenzoic acid, superior to hyponitrous acid. (3) Heat of combustion of the am. salt + 163·8 cal. per mol. at constant volume, and + 163·3 cal. at constant pressure, by explosion in compressed oxygen. (4) Heat of formation of am. salt: (a) crystallized - 25·3 cal.; (b) in solution - 32·3 cal. Heat of formation of the free acid in dilute solution = - 61·6 cal.—Oxidation of nickel carbonyl, by M. Berthelot. (See Notes.)—Tables of Vesta, by M. G. Leveau. A comparison of the meridian observations made of the minor planet Vesta, from January to April 1890, with positions given in the *Nautical Almanac*, and in an ephemeris computed by means of M. Leveau's tables of this planet. The tables are founded on 5000 meridian observations made between 1807 and 1888, and the masses taken for Jupiter and Mars, respectively, are 1/1045·63 and 1/3,648,000. The mean differences of position are greater in the *Nautical Almanac* than in M. Leveau's ephemeris, both in right ascension and declination.—On secular variations of eccentricities and inclinations, by M. J. Perchot.—On linear differential equations, by M. André Markoff.—On the dielectric power, by M. Julien Lefebvre. From experiments described, the following mean dielectric constants have been derived: sulphur (flower and roll), 2·6; sulphur, cast in rolls six months previously, 3·9; ice, different specimens, 3·45 and 2·4; ebonite, 2·3; paraffin, brown, 2·1, white, 2·0; petroleum, 1·9; carbon bisulphide, 1·7; spirits of turpentine, 1·5. The results agree fairly well with those obtained by Gordon. M. Lefebvre also finds that the dielectric constant of sulphur increases with the time.—On an application of photography to the polariscope, by MM. Chauvin and Charles Fabre.—Action of light on ruthenium peroxide, by M. A. Joly.—Salts formed by oxygen compounds of ruthenium inferior to ruthenic and heptaruthenic acids, by M. A. Joly.—On the iodonitroso and bromonitroso compounds of platinum, by M. M. Vèzes.—On the coloration of solutions of cobalt, and the state of its salts in solution, by M. A. Étard.—The nitration of silk, by MM. Léo Vignon and P. Sisley.—On the implanting of large pieces of decalcified bone to fill up losses of the substance of the skeleton, by M. Le Dentu. It has been found that pieces of decalcified bone substituted for a portion or the whole of a diseased bone plays the part of a temporary support which, before disappearing, allows the periosteum or the osseous tissue sufficient time to reconstruct a new bone.—On some phenomena of reproduction of Cirrhipedes, by M. A. Gruvel.—On the age of the fauna of Samos, by Mr. Forsyth Major.—On a Neolithic flint working (*exploitation*) of a new type, by M. Armand Viré.

## BERLIN.

**Physiological Society, October 30.**—Prof. du Bois-Reymond, President, in the chair.—Prof. Gad reported on experiments, conducted under his direction by Dr. Schtscherbak, on the alteration of the movements of eating in rabbits which result from removal of certain parts of the cerebrum.

**Meteorological Society, November 3.**—Prof. Schwalbe, President, in the chair.—Dr. Zenker spoke on the relationship of solar radiation, as it would really occur if the sun were directly overhead and there were no atmosphere, to the actually existing and observed temperatures of stations, taking into account their proximity to oceans and continents.—Prof. Hellmann made a short communication on the recent experiments in America on the artificial production of rain.

**Physical Society, November 6.**—Prof. du Bois-Reymond, President, in the chair.—Dr. Raps explained certain modifications which he had introduced into his automatic mercurial air-pumps, and demonstrated the action of the pump on a Geissler tube, which he rapidly exhausted so completely that a phosphorescent light made its appearance in it.—The President made some remarks on photographs of the human retina.—Prof. Kundt described Dr. Zehnder's new and simple differential-refractor, an instrument by means of which the two rays destined to produce interference may be kept some 50 to 100 cm. apart, and be subjected separately to varying experimental conditions.

**LONDON INSTITUTION, at 6.**—The Tower of Babel and Confusion of Tongues (Illustrated): Theo. G. Pinches.  
**CAMERA CLUB, at 8.30.**—On Toning Bromide Paper and Transparencies (with Demonstration and Illustrations): A. R. Dresser.

FRIDAY, DECEMBER 4.

**PHYSICAL SOCIETY, at 5.**—On a Permanent Magnetic Field: W. Hilbert.—Note on the Production of Rotatory Currents: Prof. Ayrton, F.R.S.  
**GEOLOGISTS' ASSOCIATION, at 8.**—Supplementary Observations on some Fossil Fishes from the English Lower Oolites: Arthur Smith Woodward.—Organic Matter as a Geological Agent: Rev. A. Irving.  
**INSTITUTION OF CIVIL ENGINEERS, at 2.**—Students' Visit to inspect the New Refrigerating Plant at Nelson's Wharf, Commercial Road, Lambeth.  
**CAMERA CLUB, at 8.**—Retouching: Redmond Barrett.

### DIARY OF SOCIETIES.

#### LONDON.

##### THURSDAY, NOVEMBER 26.

**ROYAL SOCIETY, at 4.30.**—On Instability of Periodic Motion: Sir William Thomson, Pres. R.S.—A New Mode of Respiration in the Myriapoda: F. G. Sinclair.—Further Observations on the Gestation of Indian Rays: J. Wood-Mason and A. Alcock.—On some Variations observed in the Rabbit's Liver under certain Physiological and Pathological Circumstances: Dr. Branton, F.R.S., and Dr. Delépine.—On the Electromotive Phenomena of the Mammalian Heart: W. M. Bayliss and Dr. E. H. Starling.  
**INSTITUTION OF ELECTRICAL ENGINEERS, at 8.**—Description of the Standard Volt and Ampere Meter used at the Ferry Works, Thames Ditton: Captain H. R. Sankey (late R.E.) and F. V. Andersen.  
**LONDON INSTITUTION, at 6.**—On the Spread of Commerce in Europe in Prehistoric Times: Prof. Boyd Dawkins, F.R.S.  
**CAMERA CLUB, at 8.30.**—Some Analogous Aspects of Painting, Music, and Poetry (Musical and Pictorial Illustrations): Rev. F. C. Lambert.

##### FRIDAY, NOVEMBER 27.

**INSTITUTION OF CIVIL ENGINEERS, at 7.30.**—Modern Railway Carriages: Walter Clemence.  
**CAMERA CLUB, at 8.**—Retouching: Redmond Barrett.

##### SATURDAY, NOVEMBER 28.

**ROYAL BOTANIC SOCIETY, at 3.45.**  
**ESSSEX FIELD CLUB, at 6.30.**—(Loughton).—On some Ancient Lake Remains at Felstead, with Notes on other similar Remains in the District: J. French.—The Life-History of the Hessian Fly: F. Enock.

##### SUNDAY, NOVEMBER 29.

**SUNDAY LECTURE SOCIETY, at 4.**—How came the Great Ice Age? (with Oxhydrogen Lantern Illustrations): Sir Robert S. Ball, F.R.S.

##### MONDAY, NOVEMBER 30.

**ROYAL SOCIETY, at 4.**—Anniversary Meeting.  
**SOCIETY OF ARTS, at 8.**—The Pigments and Vehicles of the Old Masters: A. P. Laurie.  
**ROYAL MICROSCOPICAL SOCIETY, at 8.**—*Conversazione*.  
**ARISTOTELIAN SOCIETY, at 8.**—Croll's Philosophical Basis of Evolution: Arthur Bouwood.  
**LONDON INSTITUTION, at 5.**—Recent Progress in Astronomy (Illustrated): Sir Robert Ball, F.R.S.  
**CAMERA CLUB, at 8.30.**—Lantern Evening.

##### TUESDAY, DECEMBER 1.

**ZOOLOGICAL SOCIETY, at 8.30.**—Notes on Transcaspian Reptiles: G. A. Boulenger.—Further Descriptions of New Butterflies from British East Africa, collected by Mr. F. J. Jackson during his Recent Expedition, Part II.: Miss E. M. Sharpe.—On the Association of Gamasids with Anis: A. D. Michæl.—Notes on the Bornean Rhinoceros: Edward Barrett.  
**INSTITUTION OF CIVIL ENGINEERS, at 8.**—Monthly Ballot for Members.—Renewed Discussion on Portland Cement and Portland-Cement Concrete: Messrs. Bamber, Carey, and Smith.

##### WEDNESDAY, DECEMBER 2.

**SOCIETY OF ARTS, at 8.**—Secondary Batteries: G. H. Robertson.  
**ENTOMOLOGICAL SOCIETY, at 7.**—Notes on *Lycena (exile Thecla)* Rhymus, *Tengstromii*, and *Pretiosa*: George T. Baker.—The Effects of Artificial Temperature on the Colouring of *Vanessa urticae* and certain other Species of Lepidoptera: Frederic Merrifield.—On the Variation in the Colour of the Cocoons of *Eriogaster lanestrus* and *Saturnia carpinii*: W. Bateson (communicated by Dr. D. Sharp, F.R.S.).

##### THURSDAY, DECEMBER 3.

**CHEMICAL SOCIETY, at 8.**—Ballot for the Election of Fellows.—Phosphorus Oxide, Part II.: Prof. Thorpe, F.R.S., and A. E. Tu-ton.—On Frangulin, Part II.: Prof. Thorpe and Dr. A. K. Miller.—The Structure and Character of Flames: A. Smithells and H. Tingle.—The Composition of Cooked Vegetables: Miss K. J. Williams.—On the Occurrence of a Mydicatic Alkaloid in Lettuce: T. S. Dymond.—On some Metallic Hydrosulphides: S. E. Linder and H. Picton.—On the Physical Constitution of some Solutions of Insoluble Sulphides: Harold Picton.—Solution and Pseudo-Solution: H. Picton and S. E. Linder.  
**LINNEAN SOCIETY, at 8.**—A Contribution to the Freshwater Algae of the West of Ireland: W. West.—The Tick Pest in Jamaica: Dr. W. H. W. Strachan.

### BOOKS, PAMPHLETS, and SERIALS RECEIVED.

**BOOKS.**—Leçons sur les Métaux, and fasc.: A. Ditte (Paris, Dunod).—Hand-book to the Geology of Derbyshire, and edition: J. M. Mello (Bemrose).—Annals of British Geology, 1890: J. F. Blake (Dulau).—The Ouse: A. J. Foster (S.P.C.K.).—Hand-book of Psychology—Feeling and Will; J. M. Baldwin (Macmillan).—Index-Catalogue of the Library of the Surgeon-General's Office, U.S. Army, vol. six: (Washington).—Electricity tested Experimentally, 3rd edition: L. Cumming (Longmans).—Problems in Chemical Arithmetic: E. J. Cox (Perivall).—An Account of British Flies, vol. i. Part 2: F. W. Theobald (Stock).—A Treatise on the Geometry of the Circle: W. J. McClelland (Macmillan).—Beast and Man in India: J. L. Kipling (Macmillan).—Principles of Agriculture: edited by R. P. Wright (Blackie).—Elementary Inorganic Chemistry, new edition: A. H. Sexton (Blackie).—Euclid, Book XI.: A. E. Layng (Blackie).  
**PAMPHLETS.**—Water and Water-Supply: J. Hopkinson (Hereford).—History of Liberia: J. H. T. McPherson (Baltimore).—The Nuptial Number of Plato: J. Adam (Clay).  
**SERIALS.**—Zeitschrift für Wissenschaftliche Zoologie, 53 Band, i. Heft (Williams and Norgate).—Cyclone Memoirs, Part 4: W. L. Dallas (Calcutta).—Journal of the Anthropological Institute, November (K. Paul).—Government of India Meteorological Department, Monthly Weather Review—March and April 1891 (Calcutta).—Indian Meteorological Memoirs, vol. iv., Part 7 (Calcutta).

### CONTENTS.

PAGE

Electro-magnetism. By Prof. A. Gray . . . . .	73
Fungus Eating . . . . .	75
"Extension Psychology." By C. Ll. M. . . . .	76
<b>Our Book Shelf:—</b>	
Dobbin: "Arithmetical Exercises in Chemistry" . . . . .	76
Pamely: "The Colliery Manager's Hand-book."—C. L. N. F. . . . .	77
Mills: "Photography Applied to the Microscope" . . . . .	77
Flammarion: "Copernic et la Découverte du Système du Monde."—G. . . . .	77
Blake: "Annals of British Geology, 1890" . . . . .	77
<b>Letters to the Editor:—</b>	
Warning Colours.—Frank E. Beddard . . . . .	78
The Salts in Natural Waters.—R. B. H. . . . .	78
Mental Arithmetic.—Clive Cuthbertson . . . . .	78
A Rare Phenomenon.—Alexander Graham Bell . . . . .	79
Henry Nottidge Moseley, F.R.S. By Prof. E. Ray Lankester, F.R.S. . . . .	79
On the Virial of a System of Hard Colliding Bodies. By Lord Rayleigh, F.R.S. . . . .	80
The Implications of Science. II. By Dr. St. George Mivart, F.R.S. . . . .	82
Examinations in Science . . . . .	85
Notes . . . . .	85
<b>Our Astronomical Column:—</b>	
Determination of the Solar Parallax . . . . .	89
Photometric Observations . . . . .	90
<b>The Pamirs . . . . .</b>	90
<b>Elizabeth Thompson Science Fund . . . . .</b>	91
<b>University and Educational Intelligence . . . . .</b>	92
<b>Scientific Serials . . . . .</b>	92
<b>Societies and Academies . . . . .</b>	92
<b>Diary of Societies . . . . .</b>	96
<b>Books, Pamphlets, and Serials Received . . . . .</b>	96

THURSDAY, DECEMBER 3, 1891.

## FIELD GEOLOGY.

*Outlines of Field Geology.* By Sir Archibald Geikie, F.R.S. (London: Macmillan and Co., 1891.)

GEOLOGISTS, we are sometimes told, are a combative race. Geologists may fearlessly allow that the impeachment has a spice of truth in it. They may take comfort when they reflect that no serious consequences have ever followed from this tendency, in spite of the facilities which the formidable weapons they carry with them offer for pushing it to an extreme. Their healthy out-door life prompts banter, and the passes are apt to be so quick and keen that the uninitiated may be pardoned if they think the buttons are off the foils.

The meetings of the Geological Society have witnessed many a sharp passage of arms. It may be permissible to recall one. A well-known member of the brotherhood, safe long ago among the majority, of large and varied experience, was indulging in just a little brag about the broad areas he had surveyed. The retort came sharp and quick from one whose quips and cranks are now alas heard no more: "Where are your maps?" And the contemptuous answer was, that the chief requisites for geological mapping were a stout pair of legs and sound wind. There were elements of truth in this lively sparring, despite its extravagance.

It is a truism that need hardly be repeated, that geology cannot be learned without out-door work, and geological excursions are a necessary item in all geological teaching. But what do they amount to? There is a leader who knows the country well. He selects a line along which sections follow one another in close succession. The exposures are so plentiful and near together that even the beginner realizes without difficulty the order in which the several rock-groups follow one above the other, and there are ample opportunities for mastering their lithological character and fossil contents. A longitudinal section is readily constructed, and figures with more or less misconception in the note-book of each of the party. An admirable start this. But what is it compared with the mental discipline that goes along with the making of a geological map, and the grip of the subject that results from this form of geological work? There is as much difference between the two as between that form of sport which consists in riding behind a pack of hounds who follow a trailed herring, and the stalking of deer in their native wilds.

It is in mapping more than in any of its other branches that geology rises to the level of an educational tool. Here there must be the instinctive skill, acquired by long practice, which leads the surveyor to select in his preliminary work the traverses most likely to give a broad view of the structure of the district he is working over; the patience which forbids, when the first rough sketch comes to be filled in, that a single square yard of ground shall be left unvisited, lest some bit of evidence should be missed; and the constructive power which pieces together the accumulated mass of multifarious data into a consistent whole. Keeness of eye, neatness of hand, judgment, unwearied application, and chastened imagination

figure among the requisites for the work, and grow in strength as it proceeds. Surely the finishing touch in a geologist's education is given by the making of a geological map.

That the art cannot be learned from books alone, goes without saying; that books can do but little towards teaching it, may be safely maintained. But there is no reason why a master should not give us in print all the aid that a book can afford, and lure us to the fascinating pursuit by an eloquent description of its charms. And that a book which deals with field-geology has been found of service, and that geologists are not averse to hear the praises of their favourite employment, are proved by the fact that the little book on this subject by the Director-General of the Geological Survey is now in its fourth edition.

The work is primarily addressed to geologists, but it appeals also to those who have no claim to so distinctive a title, and no wish for it. It shows how much pleasure may be derived from an acquaintance with the science no larger than any intelligent person may easily acquire; how even this moderate amount of knowledge enhances the enjoyment of travel and of the daily walk. But let the author speak for himself.

"To those who are fond of country rambles geology offers many attractions. Few men are so unobservant as not to be struck, now and then, by at least the more salient features of a landscape. Even in a flat, featureless country, the endless and apparently capricious curvings of the sluggish streams may occasionally suggest the question why such serpentine courses should ever have been chosen. But when the ground rises into undulations, and breaks out into hills or crags; still more, when it towers into rugged mountains, cleft by precipices down which the torrents are ever pouring, and by ravines in the depths of which the hoarse streams ceaselessly murmur, one can hardly escape the natural curiosity to know something about these singular aspects of the landscape, when and how they arose, and why they should be precisely as they are."

Our author goes on to say that "the day is now happily past when the sterner features of the land awakened only a feeling of horror; when they were styled hideous and unsightly; when they were never visited save under the necessities of travel, and were always left behind with a sense of relief." That the appreciation of the beauty of mountain scenery is a taste of modern growth can hardly be disputed. It is open to question whether the comforts of modern travel have not done as much to foster it, as a scientific curiosity to know how the forms which charm our eye were produced. But, however this may be, the awakening and the satisfying of such curiosity are added items to the stock of pleasures which the lover of Nature derives from her wilder aspects.

Some of the inducements to field-work having been thus attractively put forward, the author defines the aim of the book. The student

"must betake himself to Nature from the first. His lessons in the field should accompany his lessons from the text-book or lecture-room. In many cases he must grope his way without guide or assistance. . . . The following chapters are offered for his help. . . . Their aim is to point out how observations may be made, what kinds of data should be looked for, what sort of evidence should be sought to establish a conclusion, and

what deductions may be drawn from particular facts. In short, they are to be regarded as sign-posts pointing out some of the highways and byways of geological inquiry, but leaving the reader to perform the journey in his own fashion."

At the outset it is made clear that, though some localities supply more material than others, even the most unpromising are far from barren of interest to those who have eyes to see. The necessary equipment is fully described. In addition to the "cheese-taster" mentioned on p. 29, the portable boring-apparatus devised by Belgian geologists has been found useful. So much stress has been already laid on the value of mapping, that it will be enough to say that, in the author's opinion, the geologist "acquires by it a thoroughness of grasp attainable in no other way." It would have been well if the meaning of contour lines, and the way in which hill-shading is used to denote the shape of the surface, had been treated of more fully. The illustrations of the sinuosities of outcrop across uneven ground, on p. 101, are beautifully distinct, but nothing is said as to the value of models in making clear this point to the beginner. Of course they tell most when he makes them himself: a little modelling clay can generally be obtained; but, in default of better material, an apple or turnip can be made to do good service. In the very handy approximate rule, on p. 116, for determining the thickness of a bed when its dip and the breadth of its outcrop are known, it is not stated that the surface on which the breadth is measured must be horizontal; or, if it be an inclined plane, we must substitute for dip the sum or difference, as the case may be, of the dip of the bed and the inclination of the plane to the horizon. The error committed in using this rule for a dip of  $5^\circ$  is a little over 4 per cent. in defect; it decreases as the dip increases up to  $30^\circ$ : for that angle the rule is accurately true. For dips over  $30^\circ$  the rule gives the thicknesses too great; the error increases rather rapidly with the dip, and at  $45^\circ$  amounts to 6 per cent.; for a dip of  $50^\circ$  it is nearly 9 per cent.

The great value of the book consists in this: from beginning to end it embodies the experiences of one who has spent a lifetime in field-work, and so it is full of "wrinkles" which could not possibly have been picked up in any other way. Most of these anyone who has in him the making of a field-geologist would sooner or later have found out for himself; but it is no small gain to the beginner to be put on the right track to start with, and to have his instructions conveyed with the life and freshness that practical acquaintance can alone give. The present writer feels proud that in one respect he can claim even a more extended experience than the author of the book: the latter, apparently, has never been suspected of being an incendiary (see p. 20), a fate which once befell him who pens this notice.

A. H. GREEN.

#### THE LAND OF THE LAMAS.

*The Land of the Lamas: Notes of a Journey through China, Mongolia, and Tibet.* By William Woodville Rockhill. With Maps and Illustrations. (London: Longmans, Green, and Co., 1891.)

MR. ROCKHILL has for so long a time taken special interest in Tibet that he is able to speak of it as his "life hobby." Accordingly, when, in 1884, he

was attached to the U.S. Legation at Peking, he looked forward with pleasure to the chance of exploring the country; and he began to make the best of all preparations for the undertaking by studying the Tibetan language. At this he worked for four years, during which he also gave some time to the study of Chinese.

In the winter of 1888 he resigned his post of Secretary of Legation, and made ready for his long-anticipated journey. He determined to enter Tibet from the north, and started from Peking on December 17. The choice of this route made it necessary for him to make in the first instance for Lan-chou, the capital of the province of Kan-su; so he arranged with a cart firm to supply him with two carts, with two mules to each, to take him there in thirty-four days. For every day over this they were to pay him two taels, he giving them the same amount for every day gained on the date agreed upon. This plan worked admirably, and he reached his destination two days ahead of time. The distance was 1350 miles.

From Lan-chou, Mr. Rockhill advanced to Hsi-ning, the residence of the Chinese Imperial Controller-general of the Koko-nor, an official known to the Tibetans and Mongols as the Amban. As this magnate was strongly opposed to foreigners, Mr. Rockhill made off from Hsi-ning as soon as possible, going to Lusar, a village near Kumbum. Kumbum is a great religious centre, and he was fortunate enough to be present on the 12th of the first moon, when the Chinese in every village and town of the empire celebrate the dragon festival. After looking through one of the temples, he and those who accompanied him walked round it, keeping it on the right hand—"a mode of showing respect for sacred things observed in all lamaist countries." At a lamasery in the neighbourhood, where he found a native who had taught him Tibetan at Peking, he had much pleasant talk with various lamas. These authorities were, he says, "immensely amused" by what he had to tell them about esoteric Buddhism and the Mahatmas.

Mr. Rockhill's final preparations were made at Tankar, the most westerly border town in that part of Kan-su. From this place, with his men, he set out on March 24, 1889, and was soon across the frontier. His intention was to visit Lh'asa; and had he succeeded in carrying out this plan, his narrative would probably have taken rank among the foremost modern books of travel. Unfortunately, the difficulties in the way proved to be insuperable, and he was obliged to content himself with a much less ambitious enterprise. The first country traversed by the party was Koko-nor, their route taking them past the northern shore of the great lake from which the region derives its name. This lake is some 230 miles in circumference, and its altitude is about 10,900 feet above sea-level. Looking at it from a low pass to the north-east, Mr. Rockhill describes it as "a glistening sheet of ice, stretching as far as the eye could reach to the west, and bounded to the south by a range of high, bleak mountains with snow-tipped peaks." To the north and west of the lake there is fine grazing-land, which is watered by many streams. Here nomads find excellent camping grounds in swales and hollows, which afford protection from violent west and north-west winds.

After leaving Koko-nor, the party passed in a southerly direction through Ts'aidam, crossing the Timurté-

Mountains, beyond which they entered the desert of Koko Beileh. Starting from the village of Shang, in Ts'aidam, Mr. Rockhill explored a district which Prjevalsky did not find it convenient to visit. Here he followed the course of the Yohuré, on the left bank of which a range of mountains culminates in a peak which Mr. Rockhill estimated to be between 17,000 and 18,000 feet above sea-level. This peak he called Mount Caroline. The district was everywhere "literally alive with game," yak and wild asses being particularly plentiful. Of the Mongols of Ts'aidam, Huc and Prjevalsky have given very unfavourable accounts. Mr. Rockhill found them honest and hospitable; and he says they are much more devout Buddhists than the Koko-nor Tibetans. Among the latter, the laity "do not bother themselves about praying, thinking that they pay the lamas quite enough to do all that is necessary for their good," whereas the Ts'aidam Mongols "are continually mumbling prayers, twirling prayer-wheels, or perhaps doing both at the same time." At Shang a pole supporting two prayer-wheels was attached to the roof of nearly every house. The wheels were put in motion by the wind, which was caught by a simple arrangement of wooden cups fixed on the ends of horizontal sticks, and looking "like our anemometers.

From Ts'aidam the party entered North-Eastern Tibet, and here they traversed for the most part a bleak country until they were some way beyond Jyékundo. The country between the range to the south of Alang-nor and the source of the Yellow River has an average altitude of about 14,500 feet; and at this height the horses and dogs soon showed signs of great fatigue. "We felt no brighter than the animals," says Mr. Rockhill; "our clothes seemed to weigh tons, our guns loaded us down, and walking, even on the level, was such a violent effort that perspiration poured down our faces." They were repeatedly warned that it would be impossible for them to cross the Dré Ch'u or upper Yang-tzu Kiang. The passage, however, was effected without serious difficulty. At the point where they first saw it, the river was of a beautiful blue colour. It was about 120 yards wide and 20 feet deep, and flowed swiftly between high, bare, reddish mountains. South of the Dré Ch'u they crossed the Zonyik Valley (altitude, 16,300 feet), at the head of which they saw twelve argali, a kind of sheep which is said to be not uncommon in the wilder gorges along the river. The snow was so deep, and any exertion so exhausting, that Mr. Rockhill did not try to get a shot at them. Beyond this valley the party came to Taglung-la, (altitude, 16,650 feet), the highest pass crossed in the course of the whole journey.

Jyékundo proved to be a pretty place, nestling at the foot of a high, steep hill crowned with the brightly coloured walls of a lamasery. After the fatigues the party had undergone, Mr. Rockhill wished very much to spend a week or two at this village; but the abbot of the lamasery, who was the chief of the district, was so bitterly hostile that they had to depart in haste. During the first day's journey beyond this point the country remained bare and bleak; but when, on the following day, they entered the Dren-kou valley, which leads down to the Dré Ch'u, the scenery "changed as if by magic." They found themselves in a fertile and picturesque glen, where

juniper and pine trees grew on the mountains, while by the roadside were plum, gooseberry, honeysuckle, and other shrubs, the fragrance of their blossoms filling the air. A brook flowed between banks covered with soft green grass "powdered over with little white and pink flowers." During the remainder of the journey Mr. Rockhill was often troubled by the lamas, but in other respects his difficulties were less formidable. The route passed through many villages, and he often has occasion to express admiration for the charm of the scenery. Advancing in a south-easterly direction, he came to Dérge, the richest agricultural and manufacturing region of Eastern Tibet, and the most densely populated. It is especially famous for the excellence of its metal-work. Mr. Rockhill spent some days at Kanzé, the chief city of the Horba country, the inhabitants of which seemed to him the best-looking people he had seen in Tibet. Lu, the Chinese official stationed at Kanzé, warned him that he might encounter serious dangers beyond that city, and insisted on his taking an escort of four Chinese soldiers. Talking of wild tribes to the north of the Horba country, this official assured Mr. Rockhill that men in a state of primitive savagery were found in Tibet. Lu himself had seen a number of wild men who had been driven out of woods by a forest-fire on the flank of Mount Ka-lo, east of Kanzé. "They were very hairy, their language was incomprehensible to Tibetans, and they wore most primitive garments made of skins. He took them to belong to the same race as the Golok, of whom many lived in caves in a condition of profound savagery." From Jyékundo to Dawo, Mr. Rockhill followed the route which had been taken by Pundit A—K—, or Krishna, in 1882; but from Dawo to Ta-chien-lu he chose a different way, and thus had an opportunity of studying a new section of country, which he carefully describes. At Ta-chien-lu, his travels, so far as Tibet was concerned, came to an end. He had still before him, however, a long journey in China, and of the more striking part of it he gives an excellent account, presenting with special vigour the incidents of a trip down the Yang-tzu Kiang, which had "just enough of danger in it to give it zest."

Mr. Rockhill writes simply and clearly, and geographers will read with interest all he has to say of the more remote regions through which he passed. His remarks on the people are not less valuable. It is stated by Chinese writers of authority that for every family in Tibet there are three lamas, and Mr. Rockhill does not believe that this is an exaggerated estimate. From Jyékundo to Ta-chien-lu, a distance of about 600 miles, he passed forty lamaseries, in the smallest of which there were 100 monks, and in five of them from 2000 to 4000. Their landed property is in many cases enormous, and their serfs and bondsmen swarm. There are four lamaist sects, called by the Chinese, yellow, red, black, and white lamas; but the laity do not attribute much importance to the differences between them. In Eastern Tibet there is also a creed known as "Bön." It represents the pre-Buddhist Shamanism of the country. The "Bönbo" are held in great scorn by the lamas; but as their charge for "beating the drum" is exceptionally low, they are readily invited to the houses of the common people for religious services.

Mr. Rockhill is of opinion that polyandrous marriages, although frequently met with, are not by any means so numerous in Tibet as we have hitherto been led to suppose. Polyandry exists only in agricultural districts, and he suggests that it is maintained there because the tillable lands are of small extent, and every family feels it to be important that the ancestral estate should not be divided. This, however, as he himself points out, can at best explain, not the origin of polyandry, but merely the fact that the custom is still permitted to survive.

We may note that the illustrations are excellent, and that two good maps make it easy for the reader to trace the author's route.

#### SCIENCE AND BREWING.

*A Text-book of the Science of Brewing.* By E. R. Moritz, Ph.D., and G. H. Morris, Ph.D. Based upon a Course of Six Lectures delivered by E. R. Moritz at the Finsbury Technical College. (London: E. and F. N. Spon, 1891.)

BREWING is an industry which, as a rule, does not excite the interest in scientific minds that it deserves. The reason is difficult to explain, for there is no industry which involves more problems of general scientific moment, or makes more varied calls on the different sciences. As an illustration—noting very briefly a few points in the manufacture of beer—we have in malting a study of the embryological development of the barley plant, and the secretion and use by the growing embryo of those curious enzymes which render both the carbohydrate and proteid food of the endosperm available; in the mashing, or infusion of malt with water, we meet with the action of the enzyme, diastase, upon starch, involving some of the most complex molecular changes known; and in fermentation, produced both by the *Saccharomyces* and *Bacteria*, we have all the interesting difficulties connected with the morphology and zymotic powers of these organisms. It is evident that any technical scientific work on such subjects as those just mentioned, involves questions of the greatest general scientific interest, and touches on points at the extreme limit of our present knowledge; consequently, it is not surprising to find that science owes some most important advances to scientific workers in the field of brewing. For instance, our knowledge of the constitution of starch, and the changes it undergoes during hydrolysis by the action of acids and diastase, is almost entirely due to the researches of C. O'Sullivan and of Horace Brown, both connected with the industry of brewing.

Dealing, then, as the science of brewing does, with some of the most complex problems known, investigations in this field of work carry with them more than ordinary technical interest, and should excite more general interest in the scientific aspect of the industry than seems to be accorded to it at present. A perusal of Drs. Moritz and Morris's "Text-book of the Science of Brewing" has induced us to make these remarks, for contained in this work we find for the first time a lucid and correct account of the important scientific principles involved in the brewing industry, and the work that has been done upon them. Although, of course, mainly written for technical purposes, the authors have

treated the whole of their subject in such a manner that the book undoubtedly has a general scientific value beyond the circle of those for whom it is mainly intended. We are sure that anyone wishing to look up such subjects as starch and its transformations, or fermentation, would do well to consult this work, for, apart from the admirable *résumés* of our present knowledge on such subjects, the abundant references given, to the authors quoted, are themselves of much value.

Hitherto there has been great want of a technical guide to the scientific principles of brewing, nothing in the least worthy of such a name having been published; and the unfortunate student of this subject has been compelled to attempt the almost impossible task of collecting his information from a literature scattered far and wide, with no guide to teach him how to do it, or how to select the good from the bad when it was done. His difficulty is now over, we are pleased to say, for in Drs. Moritz and Morris's work we find a technical guide that ranks with the best of those written on any subject, and we feel sure that it will assist in a marked way in spreading a more general knowledge of the real principles of the brewing industry. One aim of the authors has been, not only to lay before their readers the present state of scientific knowledge with regard to brewing, but also by their experience as brewers to draw practical deductions from this knowledge. This part of their subject they have approached in a very fair and impartial spirit, and they have not hesitated to call attention to those points on which knowledge is at present too restricted to justify drawing deductions of any value. Those who are acquainted with the *quasi*-scientific writing that prevails in some of the brewing trade periodicals, will thoroughly appreciate this. We trust that the appearance of Drs. Moritz and Morris's work will raise the general tone of technical brewing literature, an end much to be desired.

In attempting to write a text-book bringing the scientific principles and the practice of brewing together, the authors undertook a difficult task, and one that could only be done by those who have a thorough grasp of both branches of the subject. They have been most successful in their effort, and we commend their work to the notice of all students of brewing, and to all those brewers who take a rational interest in their own business; such cannot fail to derive much benefit from a careful study of it.

#### A THEORY OF GRAVITATION.

*Fresh Light on the Dynamic Action and Ponderosity of Matter.* By "Waterdale." (London: Chapman and Hall, 1891.)

THE original aim of this work was the discovery of some reason, other than the hypothesis of attraction, to account for the gravitation of one body towards another.

The writer thus takes up the subject of gravitation where it was left by Newton two hundred years ago. The "*Principia*" concludes with these words—

"Rationem vero harum Gravitatis proprietatum ex Phænomenis nondum potui deducere, et Hypothesem non fingo. Quicquid enim ex Phænomenis non de-

ducitur, *Hypothesis* vocanda est; et Hypotheses, seu Metaphysicæ, seu Physicæ, seu Qualitatum occultarum seu Mechanicæ, in *Philosophia Experimentalis* locum non habent."

"Adjicere jam liceret nonnulla de Spiritu quodam subtilissimo corpora crassa pervadente, et in iisdem latente, cuius vi et actionibus particule corporum ad minimas distantias se mutuo attrahunt, et contiguae factæ coherant." "Sed hæc paucis exponi non possunt; neque adest sufficientis copia Experimentorum, quibus leges actionum hujus Spiritus accurate determinari et monstrari debent."

Now the present work of "Waterdale" is all Hypothesis from beginning to end; and there is no careful detailed experiment to be found described in the book, by which the various Hypotheses brought forward by him can be tested.

At a first glance the theory seems a revival of the Cartesian Theory of Vortices, advanced in Newton's day by Descartes to account for the motion of the celestial bodies, and the difficulties attending this Theory are pointed out by Newton in his "Scholium Generale"—

"Hypothesis Vorticum multis premitur difficultatibus. Ut Planeta unusquisque radio ad Solem ducto areas describat temporis proportionales, tempora periodica partium Vorticis debent esse in duplicata ratione distantiarum a Sole," &c.

This ancient theory is attributed by our author to F. Major, in his recent work, "Spacial and Atomic Energy," Parts I. and II.; but the author himself gives, as the primary reason for gravity, the *mutual shelter* to opposite wave-energy afforded by two spheres or bodies; and now, if "Waterdale" is anxious to convert the scientific world, he must utilize the quantitative theoretical results, worked out by Lord Rayleigh, on the Apparent Attraction due to Vibration.

The book abounds with curious unfamiliar dynamical expressions, such as *real, vested, imposed, and specific ponderosity, force of diversion, rectangular velocity, centering preponderating energy, film of transplacement, &c.*, of which no definitions are given; and altogether the treatment is unconventional in the extreme.

"Waterdale" concludes by asking that the question of *mechanical perpetual motion* should be reopened, and that pure mathematics should be once more applied to the subject—

"*Perpetual motion* has already been granted to us. By the burning of coal and evaporation of water we have work performed for us by Nature. Perpetuate the process, and the work is also perpetuated. We have many ways of acquiring this gift from Nature's stores, and one more possible method need not startle the human mind."

This method of quasi-scientific argument is familiar to us, in the newspapers, in the account and explanation of Spiritualistic Phenomena. A. G. G.

#### OUR BOOK SHELF.

*Indischer Ozean: ein Atlas die Physikalischen Verhältnisse, und die Verkehrs-Strassen darstellend.* (Hamburg: Deutsche Seewarte, 1891.)

THESE maps of meteorological and other physical data for the Indian Ocean, while giving a very fair idea of the prevailing conditions, are scarcely equal to the scientific requirements of the present year of grace.

While it may be freely confessed that our knowledge

of the area dealt with is yet very imperfect, and that the scale of this handy atlas does not permit of great refinements, there are many details to which exception may fairly be taken. A few instances may be given.

In the map of general depth no indication is furnished of the extreme sparseness of the soundings from which the various coloured areas are drawn.

The current charts are depicted with a hardness and regularity with regard to the different streams that are scarcely consistent with nature. The ever-varying circumstances of the monsoons render the currents of this ocean especially changeable, and it would be preferable to indicate this characteristic by lines more broken. In the sheet of the north-east monsoon period, the meeting of the two main currents on the East African coast never takes place so far south as is shown, nor is there any justification for the peculiar direction of the line between them to the eastward.

It is a bold thing to attempt to portion the sea into areas of definite surface specific gravities. The data are very scanty.

The pressure charts, which are given for the same months as those published by the Meteorological Office, and the map showing the relative prevalence of winds, are good; but here again the absence of the data on which the various quantities in different areas are founded is a serious flaw.

The different maps are well got up, and bear further witness to the general excellence of German lithography.

*Mechanics for Beginners.* Part I. Dynamics and Statics,

By the Rev. J. B. Lock. (London: Macmillan and Co., 1891.)

MR. LOCK states that the work before us contains the more elementary parts of the dynamics of a particle and of the statics of parallel forces, arranged with some additions from his "Elementary Dynamics and Statics." The author's mode of treatment will be familiar to many of our readers, and we need hardly say that Mr. Lock slurs over no difficulty that presents itself to the young student of this difficult subject. We have read the whole of the text with much interest, and pronounce it to be excellent. A boy who has gone through this, and worked out the examples in the manner shown him by the author, will be well equipped for more advanced treatises. A novelty, to which Mr. Lock draws attention, is a new form of "that proof of the formula of accelerated motion which depends upon the idea of average velocity." This proof appears to be a satisfactory one. There is an interesting combination of Morin's and Atwood's machines, which is likely to furnish a useful illustration to students. The work is split up into eight sections—rectilinear motion, motion in one plane, forces acting at a point, parallel forces, machines, uniform motion in a circle, energy, and the pendulum. The arrangement has been made to meet the special wants of the Science and Art Department. It is suited for any junior students. Article 16 appears to us to be likely to be too difficult for a boy; if so, he can pass on, and return to it subsequently. We have not worked out the examples which accompany the several chapters, and to which answers are given at the end. The following errors we have noted: p. 17, l. 8 up, dele  $a$  in  $at$ ; p. 19, l. 5 up, the first 2 N's should be N'; p. 20, last line, for 252 read 162; p. 52, l. 1, it would seem to follow that "when one mass meets another mass of the same velocity" they would not be said to *impinge*. What would they be said to do? P. 67, the term *resolute* is defined, reference might be made to p. 92; p. 68, l. 1, dele  $a$ ; p. 72, l. 8 up, for Q read R; p. 94, l. 7, for an = read +; p. 115, l. 7 up, read  $10 - x$ ; p. 139, l. 2, for 4 read 3; p. 205, last line, numerator, for  $\cos a$  read  $\sin a$ ; p. 208, l. 20, supply  $g$ ; p. 246, l. 8 up, for second  $g$  read  $g'$ . The greater number of these errors are trifling, and will not give the private student much trouble; we have pointed

them out because we know what a stumbling-block even slight mistakes are to such students. Their reverence for printed results is often wonderful. The utility of Mr. Lock's "Higher Trigonometry" is greatly hindered by the number of typographical blunders.

*The Physical Geology and Geography of Ireland.* By Edward Hull, F.R.S. Second Edition. (London: Edward Stanford, 1891.)

THE first edition of this book was reviewed in NATURE rather more than thirteen years ago (vol. xviii. p. 354). Of the second edition, which will be welcomed by all students of the subjects it deals with, we need only say that Prof. Hull has embodied in it the additions which have lately been made to our knowledge of the geological structure of Ireland. The more important of these additions he sums up under the following heads:—(1) The determination of the occurrence of Archæan rocks in certain districts of the west and north of Ireland. (2) The determination of the peculiar relations subsisting between the Lower Devonian (or Devonian-Silurian) strata and the Upper Old Red Sandstone and Carboniferous series of the southern districts. (3) Additional evidence regarding the relative ages of the trachytic and basaltic lavas of Antrim. (4) Evidence of the invasion of Ulster by a great ice-sheet from the Grampian Mountains of Scotland during the earliest stage of the Glacial period.

*The Ouse.* By A. J. Foster, M.A. (London: Society for Promoting Christian Knowledge, 1891.)

IN this little book the course of the Ouse is traced from its source to the point where it enters the sea, and some account is given of the various elements of interest that are to be met with on the way. The idea is good, and the author has worked it out skillfully. Any boys or girls who may read the volume will find at the close that they have obtained from it much sound geographical knowledge.

#### LETTERS TO THE EDITOR.

[The Editor does not hold himself responsible for opinions expressed by his correspondents. Neither can he undertake to return, or to correspond with the writers of, rejected manuscripts intended for this or any other part of NATURE. No notice is taken of anonymous communications.]

#### A Difficulty in Weismannism.

IN your number of October 29 (vol. xlv. p. 613), Prof. Hartog depicts a dilemma in which a study of Weismann's theories has placed him.

Prof. Hartog sums up the main points of Weismann's theories in five theses, but, considering the great importance which the latter attaches to the operation of *natural selection*, he might well have added a *sixth* to the list.

There can be no doubt that, of the two hypotheses brought forward in the letter, hypothesis B is the one adopted by Weismann for the explanation of the problems of heredity. We are therefore not concerned with hypothesis A.

"According to hypothesis B," Prof. Hartog states, "the Ahnenplasmas of all Metazoa being similar and Protozoan, if the numbers are equal and the shuffling fair, any two parents may beget any offspring whatever; . . . a lioness might be expected to bring forth a lobster or a starfish, &c."

What does Prof. Hartog mean by *fair shuffling*? Surely not such shuffling as is resorted to in the game of whist, but such shuffling as he himself describes in thesis 4. He states here that the "process is comparable to the shuffling of two packs of cards by taking half from each and joining the two packs or remainders to form a new pack."

It surely cannot be imagined that Weismann ever intended to assert that with each sexual act there was a rearrangement of

the Ahnenplasmas comparable to the shuffling of a pack of cards during the game of whist.

Did he anywhere assert this, we should naturally expect him to believe that a lioness might as well bring forth human beings or lobsters as normal cubs.

With the evolution of sexuality, the excessively numerous Ahnenplasmas of our variable Protozoan ancestors became arranged in more and more complex, ever-varying combinations. At the very outset, natural selection operated. The variations (due to the combinations) most advantageous to the species were perpetuated. Unfavourable variations involved extinction. It is the *special combination* of the units of ancestral germ-plasm which predetermines the structure of the mature individual. This combination, of course, is very closely related to the two combinations from which it arose, and it is just this closeness of relationship which prevents us from supposing that a lioness can ever produce anything but cubs. Changes in the combinations are only slowly effected. The influence of the mother is due to the fact that one-half of the maternal combination is present in the offspring, and similar statements can of course be made concerning the influences of father, grandfather, great-grandfather, &c.

Do not these two considerations—(1) that the nature of the individual depends upon the *peculiar combination* of units of ancestral Protozoan germ-plasm, a combination very closely related to two previous ones (owing to the fact that, in sexual union, two halves of immediately preceding combinations are united to make one whole); (2) that the operation of natural selection provides for the *extinction of useless*, and the *preservation of useful variations*—afford to Prof. Hartog the means of escaping from his dilemma? A. H. TROW.

Penarth, Cardiff, November 14.

THE contributions of Mr. Trow and Dr. Poulton to this discussion render necessary an explanation that should, perhaps, have accompanied my first letter. After rough-drafting this, I felt misgivings lest I might have misconceived Weismann's meaning, and set up a man of straw to knock down. Accordingly, I wrote to Prof. Weismann to ask if I rightly understood his meaning, explaining my object in doing so; and he answered my queries with great kindness, courtesy, and fulness. As I wrote back to him, I then thought it better, relieved from my misgivings, to state the point without reference to his letter. But Mr. Trow and Dr. Poulton have both blamed my use of the word shuffling, and appear to think that my hypothesis A is a purely imaginary conception of the straw man order. I hope, therefore, I shall not be accused of having wilfully kept a trump card up my sleeve if I now quote the two essential passages of Prof. Weismann's letter, which were written in definition of the points at issue.

"Ich denke mir dass das Keimplasma eines Individuum's aus einer gewissen Zahl von Einheiten besteht, welche untereinander sehr ähnlich, aber nicht gleich sind. Die Unterschiede zwischen ihnen entsprechen meist den Unterschieden zwischen je zwei Individuen derselben Species. Jedes derselben würde im Stande sein ein Individuum der Art hervorzubringen falls es sich zu der dazu nöthigen Masse vervielfältigen könnte oder würde." The sentence I have italicized corresponds, I think, very fairly to my hypothesis A: "Each Ahnenplasma unit corresponds to an individual of the species itself; and if put under suitable trophic conditions would, singly, reproduce such an individual." Dr. Poulton writes: "I agree with Prof. Hartog in considering it [Hypothesis A] as valueless." I am far from considering any hypothesis as valueless which upsets a wrong theory of which it should be the mainstay.

Prof. Weismann goes on: "Sie können ganz wohl die geschlechtliche Fortpflanzung mit dem Mischen eines Kartenspiels vergleichen, aus dem immer die Hälfte der Karten entfernt wird. Nur ist nicht zu vergessen dass die Karten selbst nicht völlig unveränderlich sind." It is obvious that Prof. Weismann accepts the peculiar mode of shuffling I have described (not the ordinary mode at whist), as a fair illustration of his conception of fertilization and its antecedents. He always speaks of combinations in his "Essays," and not permutations. The reason is obvious: the figured elements of the living nucleus are constantly changing their relative position; and it is these that are the outward and visible sign of the mysterious ancestral units.



Hence Dr. Poulton's very pretty kaleidoscope simile involves new suppositions, which are worse than gratuitous because they involve throwing overboard the very facts on which the theory was originally based. It is plain that Dr. Weismann goes very much further in admitting the changeability of the ancestral units than his disciples are willing to do; and I have shown that hypothesis A involves the conclusion that these are indefinitely changeable, not merely "not completely unchangeable," as Prof. Weismann writes.

Another point for consideration is that we can hardly doubt the monophyletic origin of Metazoa, and that, at least excepting Cœlenterates and Sponges, they all originated from some one primitive form. The Protozoan ancestors of this form must have belonged to the same species with one another, and their representative ancestral units cannot have been more different than the members of a single species. Hence, without selection, the germ-plasm composed of a number of these units associated together would give an average resultant, so that the majority of individuals would be more similar than the ancestral units of their germ-plasms, and amphigony would produce uniform offspring on the whole. Divergence from the average type could only occur by the duplication or further repetition of single ancestral units of special character; and these variations would be the material for natural selection to act upon. Thus, among words of eleven letters, such a word as *abracadabra*, with its 5 *a*'s, 2 *b*'s, and 2 *r*'s, would have a marked divergence from the type as compared with groups in which no letter occurred twice over.<sup>1</sup> If, then, natural selection goes on to form a species according to Weismann's theory, it can only do so by eliminating certain ancestral plasms and duplicating or further repeating others to take their place. Once an ancestral plasm eliminated in the formation of a race it can never be re-introduced, or replaced by a new one. But as soon as we repeat certain members of a group of limited number we reduce the possible number of permutations or combinations that can be formed from that group. Anyone with a fair head for the work, and a Todhunter's "Algebra," can see for himself how very rapidly the number of combinations is reduced in this way. Thus natural selection could only result in arrangements of ever-increasing simplicity and similarity instead of complexity and divergence. The ultimate product would be a limited number of well-marked species, whose individual members had lost all power of variation. This I offer as an alternative to the variable offspring of the Ilnesses.

Mr. Trow is extremely anxious to show me a path out of my dilemma. It presents no difficulty to those biologists who consider the conception of a germ-plasm independent of the somatoplasm as more or less mythical. For those who follow Weismann, the way out of the difficulty will not lie through the ascription to natural selection of powers which it cannot possibly exert.

MARCUS HARTOG.

Exct. November 28.

### The Mexican Atlatl or Spear-Thrower.

THE note in NATURE of November 19 (p. 66) recording the important discovery at Lake Patzcuaro, Mexico, of "a modern atlatl (not atlatl, as misprinted) well worn and old-looking, accompanied with a gig for killing ducks," is very interesting. It may not be out of place to call attention to an exhaustive little memoir by Mrs. Zelia Nuttall on "The Atlatl or Spear-Thrower of the Ancient Mexicans," published this summer in the third number of the first volume of the "Ethnographical and Ethnological Papers of the Peabody Museum" (Cambridge, Mass., 1891). In this paper, which is illustrated with eighty figures of different kinds of atlatl, the author completely establishes the existence and practical use in warfare of the wooden spear-thrower or atlatl by the Mexicans at the time of the Spanish conquest, although some doubt had been expressed in the matter by such well-known authorities as Prof. E. B. Tylor and Mr. A. Bandler, while Mr. H. H. Bancroft even stated that "he had not found any description of its form or the manner of using it." Mrs. Nuttall, however, reproduces numerous illustrations of the many varied forms of the atlatl from different codices, accompanied by several descriptions of the manner of hurling the weapon, cited from old Spanish writers. Perhaps at this moment the most *à propos* is that from the

ancient chronicles of Tezozomoc, who, in describing the drill of the soldiers, relates "how their chiefs ordered them out in canoes to practise throwing spears at flying ducks before engaging the enemy in warfare." Mrs. Nuttall was enabled to trace, by means of a careful study of a MS. edition of "Sahagun's Historia," preserved in the National Library at Florence, the complete evolution of the atlatl from the simple form used by the native hunter to launch the harpoon with two or three barbs at the fish or water-fowl of the lagoons. This had a cord attached to retrieve the game. "Minus the cord, the spear-thrower became part of the necessary equipment of every soldier of a certain grade," and was used with fatal effect, as Bernal Diaz most distinctly states, in opposing the advance of the Spanish adventurers. Elaborately decorated forms first became the emblem of chieftainship, and ultimately symbolic of the Aztec deities, and were borne aloft by the chief-priestly warrior and representative of the gods in ceremonial processions. The maximum of development was attained in the symbolic "blue atlatl" or "blue serpents," inlaid with gold and richly decorated with feather-work, described as "bishops' croziers" by Cortes, who sent specimens presented to him by Montezuma II. to the Court of Spain. Some examples are still preserved in the Ethnographical Museums of Berlin and Vienna, and in the British Museum.

It was in the course of these researches that Mrs. Nuttall made the important identification of the atlatl "as the hitherto unrecognized weapon" grasped by the warriors sculptured on the "so-called sacrificial stone of Mexico," and also by the warriors depicted in Stephens's illustrations of the *bas-reliefs* adorning the ruins at Chichen-Itza in Yucatan. The different myths relating the invention or origin of the atlatl are collected and explained, and the following very practical philological derivation of the name atlatl is offered by her as a suggestion supported by a series of careful analyses:—

"The Aztec word atlatl, or atlatli, is intimately connected with the verb *tlaca* = to aim, to throw, or cast. From this verb a whole series of words is formed, as *tlatlacaliztli* = the act of throwing, &c.; *tlatlaxli* = the object thrown; *tlatlacani* = thrower. The name atlatl—a synthesis of *atl*, water, *tlacatl*, men—was applied to the fishermen, the original users of the atlatl; and it is suggested that the word atlatl may primarily have been a synthesis formed with the verbal noun *tlatlacani* = thrower, and *atl*, water, which would give the word *atlalacani*, meaning water-thrower, not an unfit name for the harpoon-thrower of the watermen" (p. 12).

This interpretation is certainly not weakened by the recent discovery that the primitive form of atlatl is still in use in the lake regions of Mexico. In other respects Mrs. Nuttall's paper well repays perusal by all interested in Mexican antiquities.

A word with reference to Prof. Otis Mason's remark "that the problem now is to connect Alaska with Mexico." Given hungry aboriginal man in the foreground, and fat wild ducks in what artists term "the middle distance," it does not seem wholly irrational to surmise that the atlatl, or spear-thrower, was independently evolved in suitable environments. Does not the average nineteenth-century boy still betray a strong innate tendency to throw or sling stones at every bird he sees? Perhaps this is but accumulated inherited instinct, not yet eradicated by civilization. It is at all events certain that the atlatl was widely used by the aboriginal inhabitants of the American continents, as Prof. Max Uhle's researches testify abundantly.

Brighton, November 21. AGNES CRANE.

### The Chromosphere Line Ångström 6676.9.

WITH regard to Prof. Young's observations as to the non-coincidence of the bright chromosphere line (NATURE, November 12, p. 28) with the corresponding dark line 6676.9 of Ångström's scale, it may be interesting to note that Profs. Liveing and Dewar have observed a barium line at 6677, which is therefore slightly less refrangible than the dark solar line. In his catalogue Prof. Young also gives a barium line at 6018.0, which is identified with Kirchhoff 933.8. In the course of the observations of sun-spot spectra taken at Stonyhurst with a twelve-prism spectroscope, no dark solar line has been noted in this position except in two uncertain instances over spots. It would be an important fact should two barium lines be found in the chromosphere without corresponding dark lines.

<sup>1</sup> The argument above was suggested to me by a chemical friend.

In the period of maximum solar activity the bright line 6676.9 was on several occasions seen in the spectroscop, while the height of the chromosphere was being measured at Stonyhurst on the C line of hydrogen. At these times C was always very bright, and generally displaced in the prominences in which 6676.9 was seen. The latter line was not seen in the observations taken between March 9, 1886, and September 10, 1891. Although both Young and Thollon attribute the line to iron, no iron line is given in this position by either Ångström or the catalogues of the British Association. Dunér, quoted by Thollon, considers the line variable with the state of solar activity, but Ångström seems to have made an error in drawing it as a fine thin line, as Kirchhoff, Burton, Fievez, Smyth, Thollon, and Higgs give it as a strong dark line. Finally, Young, Burton, and the Stonyhurst observers identify it with Kirchhoff's ray 654.3, and Thollon with 641, which latter is a calcium line. There would, then, appear to be some differences of opinion with regard to this important line (cf. *Monthly Notices R.A.S.*, vol. ii., No. 1, p. 22.) A. L. CORTIE.  
St. Beuno's College, St. Asaph, November 19.

Peculiar Eyes.

LABOUR under the peculiar inconvenience of having a right eye of normal power and a short-sighted left eye. The numerals on the face of a clock  $\frac{1}{2}$  of an inch high are visible to the right eye at 12 feet distant; but in order to discern them as clearly with my left eye I require to bring that organ of vision as near to the figures as 8 inches. On looking at my gold chain hanging on my breast in daylight and with both eyes, the chain, coloured yellow and towards the left, is perceived by the right eye, while a steely blue chain, another, yet the same, is perceived about an inch to the right and a little higher up. By artificial light the same phenomenon presents itself, but the difference of colour is not so apparent; the yellow to the right is only dimmer. Again, when a page of NATURE is being read with the short-sighted eye, there appears, about an inch to the left, part of the same column, small, and the black, under artificial light, like weak purple. The right-hand side of this ghost-like column is lost to the right eye, being commingled with the larger, darker letters seen by the short-sighted left, which cover it like the more recent writing on a palimpsest. Middle life was reached before the discovery was made. These experiences must be gone through with intent, for objects generally being perceived altogether with the right eye, all that the left seems good for is to supply a little more light. The perception of the difference of colour is as good with the one eye as the other, and the short-sighted eye can read smaller type.

As the inferior animals, so far as I know, have no habit of peeping or looking with one eye shut and the other open, it occurred to me that this ability might be a limited one. I tried the experiment with school children, and to my surprise found that a few were quite unable to keep one eye shut and the other open at the same time, and a few did it with an effort, making in all about a fourth of the number. Adults were likewise under similar limits, but to a less extent. This may be the reason why the discovery of inequality of vision, as Sir John Herschel remarks, is often made late in life. Indeed, he mentions an elderly person who made the unpleasant discovery that he was altogether blind of an eye. JAS. SHAW.  
Tynron, Dumfriesshire.

Zoological Regions.

The last number of the *Archiv für Naturgeschichte*, lvii., which has just appeared, contains (pp. 277-291, pl. x.) an article by Prof. Möbius, dealing with the zoological regions of the earth, chiefly with a cartographical and "museological" object, in which a set of regions is proposed differing in some respects from that most generally in use. The number of land regions is raised to twelve instead of the usual five or six, and the marine world is likewise subdivided into a number of regions. A part of what may appear innovations is in fact nothing but a reversion to the zoological subdivisions of the world proposed by Schmarada ("Geographische Verbreitung der Thiere") in 1853. It seems extraordinary that, although alluding to the works of the principal authorities who have dealt

with zoogeography since Schmarada, Prof. Möbius should not have referred to that author otherwise than in a second-hand quotation. For not only did Schmarada lay down the basis on which zoological regions have since been elaborated, but his attempt is, everything considered, in many respects superior to that of his immediate successors in the same field.

It will be seen, on comparing Schmarada's and Möbius's maps, or the table annexed to this note, that several of the regions independently proposed by these authors coincide in their limits, the principal difference being that Schmarada divided the world into a greater number of "Reiche," some of which are merely amalgamated in Möbius's "Gebiete."

G. A. BOULENGER.

SCHMARADA, 1853.

MÖBIUS, 1891.

A. Festland. =	A. Landgebiete.
I. Arctisches Reich .. =	I. Nordpolar Gebiet.
II. Mittel-Europa ... =	II. Europäisch-Sibirisches G. (+ part of Schmarada's I. R.)
V. Mittelmeer Reich ... =	III. Mittelmeer G.
III. Kaspiische Steppenländer ... =	
IX. Wüste ... =	
IV. Centralasiatische Steppen ... =	IV. Chinesisches G.
VI. China ... =	
LVII. Japan ... =	
VIII. Nordamerica ... =	X. Nordamerikanisches G.
X. Westafrika ... =	VI. Afrikanisches G.
XI. Hochafrika ... =	VII. Madagassisches G.
XII. Madagascar ... =	V. Indisches G.
XIII. Indien ... =	VIII. Australisches G.
XIV. Sunda-Welt ... =	
XV. Australisches Reich ... =	
XVI. American. Mittelreich ... =	
XVII. Brasilien ... =	
XVIII. Ando-peruan.-chil. R. ... =	-XI. Südamerikanisches G.
XIX. Pampas ... =	
XX. Patagonien ... =	
XXI. Polinesien ... =	{ VIII. (Part). IX. Neuseeländisches G.
B. Meer. =	B. Meergebiete.
XXII. Arctisches M. ... =	I. Nordpolar M.
XXIII. Antarktisches M. ... =	
XXX. Südt. Atlant. Oc. ... =	VIII. Süd-M.
XXXI. Südt. Stiller Oc. ... =	
XXIV. Nördl. Atlant. Oc. ... =	II. Nordatlant. M.
XXV. S. Eur. Mittel-M. ... =	III. Mittel-M.
XXVI. Nördl. Stiller Oc. ... =	VII. Nordpazifisches M.
XXVII. Trop. Atlant. Oc. ... =	IV. Südamerikanisches M.
XXVIII. Indischer Oc. ... =	{ V. Indisch-Polynesisches M.
XXIX. Trop. Stiller Oc. ... =	{ VI. Peruanisches M.

Scientific Nomenclature.

A propos of Prof. Parker's interesting article on scientific nomenclature in your issue of the 19th inst. (p. 68), I should like to call attention to the misuse of the term involucre in regard to the Anemone, &c. The so-called involucre of the Anemone is really, morphologically, a calyx, and until the flower-bud has grown to the height of an inch or two from the ground, it to a certain extent performs the ordinary functions of a calyx. Then an internode is developed between the calyx and corolla. But the presence of this internode, long as it is, should no more prevent our assigning to the calyx its proper name, than does the slight internode existing between the calyx and corolla of *Lychnis diurna*.

Great Malvern. H. ST. A. ALDER.

"The Darwinian Society."

I WOULD call Mr. White's attention to the fact that the name of this Society is not "The Darwinian Society," but "The Edinburgh University Darwinian Society"—a name which, considering Darwin's connection with the University and with a similar Society here, I think we are quite entitled to assume.

University of Edinburgh, [Secretary].  
November 24.

SOME NOTES ON THE FRANKFORT INTERNATIONAL ELECTRICAL EXHIBITION.<sup>1</sup>

## VI.

*The Frankfort Motor and the Lauffen Dynamo.*

IN all the motors described in Part V. the magnetism of the stationary iron ring is being rapidly reversed, while that of the moving interior varies at a rate which is equal to only the difference between the speeds of the rotatory magnetic field and the rotating central portion of the motor. This difference is always comparatively small in a well-designed multiphase motor, even when loaded, and becomes practically nought for light loads. Hence we may regard a multiphase motor as roughly one in which the magnetism of the rotating iron interior remains unchanged relatively to the iron itself, while that of the stationary iron ring varies rapidly.

certain that the smaller density of the lines of force in the stationary ring do not more than compensate for the increased length of their path, a point to which we venture to think Mr. Dobrowolski has not given sufficient attention when coming to this decision to turn the multiphase motor inside out.

However, be that as it may, Fig. 32 shows the multiphase motor of 100 horse-power nominal, which the considerations described in this and the previous article led Mr. Dobrowolski to construct for being worked at Frankfort by a portion of the power generated at Lauffen 100 miles away.

To lead the currents coming along the mains to the rotating interior of the motor, three rubbing contacts must be employed; indeed, six contacts become necessary if we desire to be able to couple up the coils on the motor in open or closed circuits (Figs. 20 and 24, pp. 56 and 57)—an arrangement provided for in the Frankfort motor

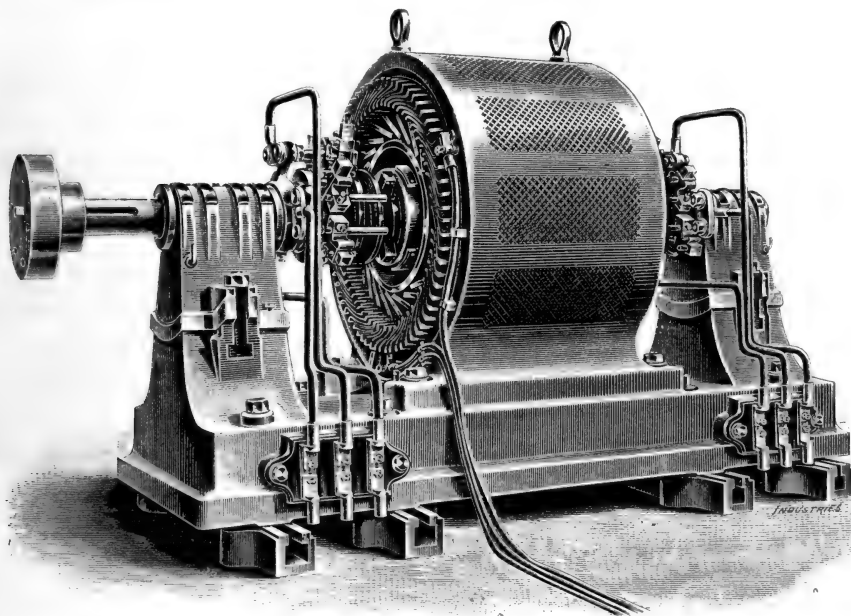

FIG. 32.—The Frankfort 100 horse-power rotatory current motor.

Now whenever the magnetism of iron is being rapidly reversed, there is loss of power; the magnitude of the loss, for a given rate of reversal and quality of iron, depending on the intensity of the magnetization and the mass of the iron acted on. And, as the length of the lines of force in the outer stationary iron ring of the multiphase motor is necessarily longer than in the interior rotating portion, Mr. Dobrowolski concluded that less power would be wasted if he inverted the functions of the stationary and rotating parts, sending the multiphase alternate currents round the interior rotating laminated iron drum, and attaching the short-circuited conductors, in which currents are induced by the rotating magnetic field, to the *inside* of the stationary laminated iron ring, so as to form a kind of short-circuited Siemens armature turned inside out.

The preceding conclusion is undoubtedly correct if it be

<sup>1</sup> Concluded from p. 60.

(Fig. 32). The great simplicity of the original Ferraris' motor is thus abandoned, but, although this would be disadvantageous in the case of small motors, where simplicity and freedom from sparking are all-important, the change is not so serious in a large motor, like that shown in Fig. 32, since high efficiency, and therefore small waste of power, combined with relatively small first cost, are the main things to be aimed at in large motors.

Another reason why the application of rubbing contacts to a large rotatory-field motor is less objectionable than might at first sight appear arises from the fact that, even if the motor were constructed in one of the original forms shown in the preceding article, it would be necessary to employ rubbing contacts for a totally different reason, viz. to introduce resistance, at the moment of starting the motor, into the circuits which carry the currents induced by the rotating magnetic field. Whereas, if these currents be induced in conductors attached to the stationary ring,

such a resistance can be introduced without extra rubbing contacts; and it is for the purpose of introducing this resistance into these stationary circuits that the three wires, trailing on the ground in Fig. 32, are seen attached to the conductors attached inside the stationary part of the motor.

The necessity, at starting the motor, for increasing the resistance of the conductors carrying the induced currents will appear from the following consideration. When the motor (Fig. 32) is running at full speed under a light load, the interior part rotates at such a rate—relatively to the frequency of alternation of the currents in the main wires—that the magnetic field is practically stationary, just as it is in an ordinary direct current motor. But at

into the circuits of the stationary conductors of his large motors while the motor is getting up speed.

We have hitherto spoken of the conductors on the rotating part as being wound on the outside of a laminated iron drum, and those on the stationary part as being wound on the inner surface of a laminated iron ring; but, as a matter of fact, in the large Frankfort motor both sets are composed of copper rods, insulated in asbestos tubes, and slipped into holes punched out of the iron close to the periphery. This burying of the copper bars to a small depth inside the iron has been adopted because it has been found that the generation of Foucault currents in the thick bars can in this way be more effectively prevented than by following the method usually adopted with bar

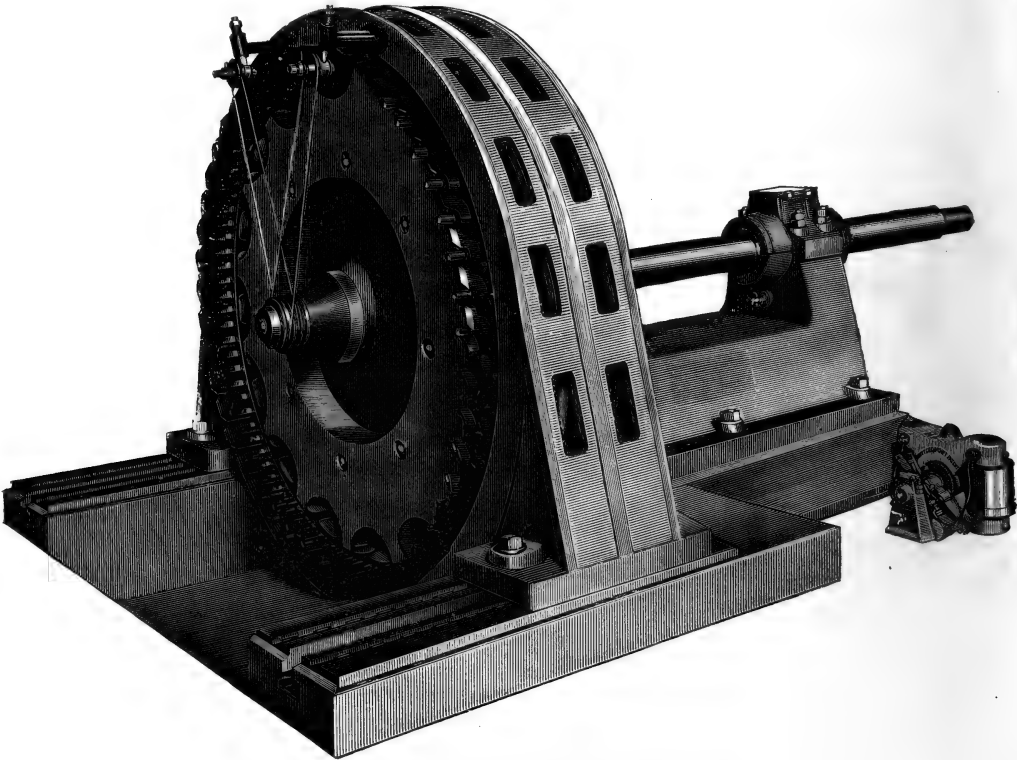

FIG. 33.—The Lauffen three-phase alternate current dynamo and exciter.

the start, the interior laminated iron drum is only moving slowly, while the currents flowing in the conductors attached to it are alternating rapidly, hence the magnetic field is rotating rapidly, and powerful currents are induced in the stationary conductors, so powerful, in fact, as to produce a magnetic field which seriously distorts that produced by the main alternating currents. In fact, there is the same antagonism of magnetic fields that occurs with a direct current motor, if the armature field be very powerful in comparison with that of the field magnet, and if the lead of the brushes be adjusted so as to cause the fields to oppose one another; and it is to avoid this result that M. Dobrowolski introduces a liquid resistance

armatures, which consists in moulding each conductor out of stranded copper wire with the various wires composing the strand partially insulated from one another.

No tests have yet been published of the power and efficiency of this machine, but the smoothness with which it ran, pumping up water for the artificial waterfall in the Frankfort Exhibition, and the absence of the roar audible with some alternate current machines, and even of the rhythmical hum noticeable with the best alternate current motors, were very striking.

In the last article it was proved that if three harmonic alternating currents of the same periodic time and maximum amplitude, but differing by  $120^\circ$  in phase, flowed in

three wires, A, B, C (Figs. 20, 21, 22), each current was at any moment algebraically equal to the sum of the other two. To test, therefore, whether the currents flowing in the three parallel wires between Lauffen and Frankfort fulfilled this condition, we had merely to find out whether any current was induced in a neighbouring telegraph wire which was sufficiently far away as to be practically at the same distance from each of the Lauffen-Frankfort wires.

Between Frankfort and Hanau the power wires are carried on one side of a broad railway, and for some eight or nine miles the telegraph wires run on the other side; the telegraph wires for the remainder of the distance between Frankfort and Hanau following quite a different route. If one of these telegraph wires were put to earth at Frankfort and at Hanau, and if a telephone were placed in the circuit, a confused chattering of telegraph instruments was always heard in this telephone, due to induction from the telegraph lines on the same posts. But during the hours that power was being transmitted

ways, leaving the field magnet in position, as seen in Fig. 34. Each of the 32 flat-looking plates round the circumference of the field-magnet is a magnetic pole, the poles being alternately north and south. This result is attained by constructing the field magnet in the ingenious manner shown in Fig. 35, the coil which carries the direct current to magnetize this field magnet being wound in the circumferential channel seen in section in Fig. 35.

The armature bars, 96 in number, are constructed of copper rods 29 mm. in diameter, insulated in asbestos tubes, and slipped through holes (parallel to the axis of rotation) punched out of the laminated iron ring which composes the armature core; this burying of the con-

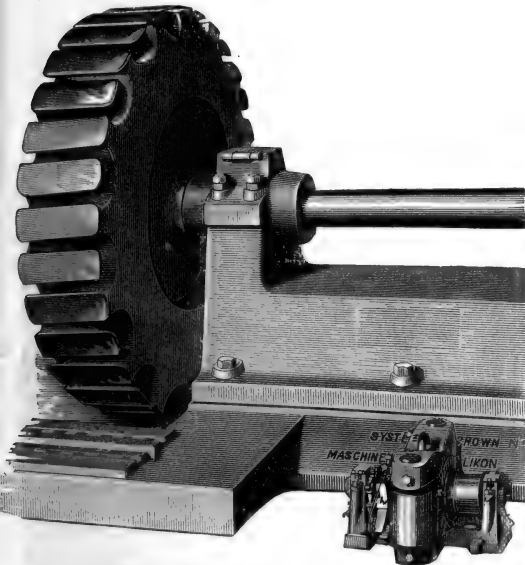

FIG. 34.—Field magnet of the Lauffen three-phase alternate current dynamo.

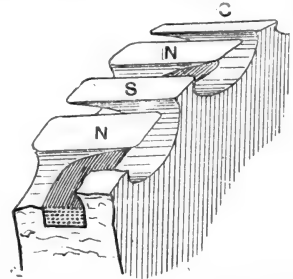

FIG. 35.—Section of the field magnet of the Lauffen dynamo.

ductors to a small depth in the iron being, as already explained in the case of the Dobrowolski motor, for the purpose of avoiding Foucault currents being induced in the thick copper bars.

A portion of the three separate windings, *aaaa*, *bbbb*, *cccc*, on the armature is shown in Fig. 36, which represents a bit of the circumferential part laid out flat; the dotted rectangles indicate the poles, and to avoid confusion the armature bars, parallel to the length of the poles, are drawn longer in proportion than they really are.

In order that the electromotive forces induced in all the up and down bars of any one of the windings *aaaa* in Fig. 36 should help one another, the distance between

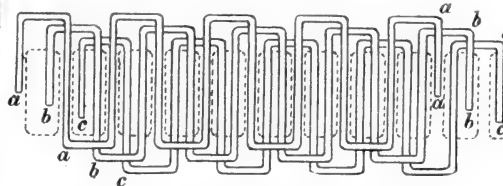

FIG. 36.—Portion of the armature-winding of the Lauffen three-phase alternate current dynamo.

through the wires on the other side of the broad railway a rhythmical hum could be detected superimposed on the confused babel of telegraph signals, proving that the three alternate currents were either not truly sine currents, or that their phase difference was not accurately  $120^\circ$ .

To generate the three-phase current at Lauffen, the extremely compact dynamo shown in Fig. 33 was designed by Mr. Brown, and constructed at the Oerlikon Works, near Zurich. The armature is wound with three distinct circuits, each arranged to give 1400 amperes at a potential difference of 50 volts, so that the dynamo can develop 300 horse-power. To avoid, as far as possible, rubbing contacts, the armature remains stationary and the field magnet revolves; while by the employment of 32 poles a frequency of 40 complete alternations per second can be obtained in each circuit when the field magnet only makes 150 revolutions per minute.

For examining the interior, the armature, which forms the outside shell of the machine, can be withdrawn side-

any up and the adjacent down conductor of the same winding must be equal to the distance between two adjacent poles—that is, to  $1/32$  of the circumference of the armature; and in order that the electromotive force generated by the winding *bbbb* should differ in phase by  $120^\circ$  from the electromotive force generated in the winding *aaaa*, the distance between an up bar of the winding *aaaa* and the following up bar of the winding *bbbb* must be two-thirds of the distance between the centres of two adjacent poles—that is, must be  $1/48$  of the circumference of the armature. Similarly, an up bar of the winding *cccc* must be behind the preceding up bar of the winding *cccc* by  $1/48$  of the circumference of the armature.

The exciting current is led into the field magnet by the novel employment of the two endless metallic cords seen to the left of Fig. 33, which saves the necessity of using a standard to carry contact brushes, and the smallness of the power spent in exciting the field magnet, compared with the power developed by the machine, is seen from the dwarf-like character of the direct current exciting dynamo in Figs. 33 and 34.<sup>1</sup>

This three-phase alternate current dynamo of Mr. Brown's, on account of the simplicity and solidity of its design, the slow speed of its rotation, and the entire absence of the experimental makeshifts which are supposed to be characteristic of an electrician, but which are in reality evidences of the rapid development of his tools, appeals especially to the mechanical engineer. It is therefore probable that the employment of so well constructed a dynamo at Lauffen, and so smoothly running a motor at Frankfurt, will bring home to the mechanical engineer that he can now avail himself, for the practical transmission of power, of that silent carrier electricity—a carrier which, while it can communicate a great force almost instantaneously to a vast distance through a thin wire, travels itself so leisurely that, in its steady flow, it experiences no extra difficulty whether it goes up hill or down dale, overhead or underground, in a straight line or round a succession of sharp corners.

EXPERIMENTS IN AERODYNAMICS.<sup>2</sup>

THE subject of this memoir is of especial interest at the present time, when the skill of a distinguished inventor is understood to be engaged in attacking the many practical difficulties which lie in the way of artificial flight upon a large scale. For a long time the resistance of fluids formed an unsatisfactory chapter in our treatises on hydrodynamics. According to the early suggestions of Newton, the resistances are (1) proportional to the surfaces of the solid bodies acted upon, to the densities of the fluids, and to the squares of the velocities; while (2) "the direct impulse of a fluid on a plane surface is to its absolute oblique impulse on the same surface as the square of the radius of the sine of the angle of incidence." The author of the work<sup>3</sup> from which these words are quoted, in comparing the above statements with the experimental results available in his time (1822), remarks:—" (1) It is very consonant to experiment that the resistances are proportional to the squares of the velocities. . . (2) It appears from a comparison of all the experiments, that the impulses and resistances are very nearly in the proportion of the surfaces. . . (3) The resistances do by no means vary in the duplicate ratio of the sines of the angle of incidence." And he subsequently states that for small angles the resistances are more nearly proportional to the sines of incidence than to their squares.

It is probable that the law of velocity tended to support in men's minds the law of the square of the sine. For, if both be admitted, it follows that the resistance, normal to the surface, experienced by a plane when immersed in a stream of fluid, depends only upon the component of the velocity perpendicular to the surface. That the effect should be independent of the component parallel to the plane seems plausible, inasmuch as this component, if it existed alone, would exercise no pressure; but that such a view is entirely erroneous has been long recognized by practical men, especially by those concerned in navigation.

From the law of the simple sine, enunciated by Robison, it follows at once that the pressure upon a lamina

exposed perpendicularly to a stream may be increased to any extent by imparting to the lamina a sufficiently high velocity in its own plane. The immense importance of this principle was clearly recognized by Mr. Wenham in his valuable paper upon flight;<sup>4</sup> and a few years later the whole subject was discussed by the greatest authority upon such matters, the late Mr. W. Froude, with characteristic insight and lucidity.<sup>2</sup>

The theoretical problem of determining the resistance from the first principles of hydrodynamics is not free from difficulty, even in the case of two dimensions, where a long rectangular lamina is exposed obliquely to a stream whose direction is perpendicular to the longer sides. The formula<sup>3</sup> resulting from the theory of Kirchhoff, viz.

$$\frac{\pi \sin \alpha}{4 + \pi \sin \alpha} \rho V^2, \dots \dots \dots (1)$$

where  $\rho$  is the density of the fluid, and  $V$  is the total velocity of the stream flowing at the angle  $\alpha$  with the plane of the lamina, shows that when  $\alpha$  is small the resistance is nearly proportional to  $\sin \alpha$ . Moreover, (1) agrees with the experiments of Vince.<sup>4</sup>

It will be seen that the laws of resistance were fairly well established many years ago, at least in their main outlines. Nevertheless, there was ample room for the systematic and highly elaborate experiments recorded in the memoir whose title stands at the head of this article.

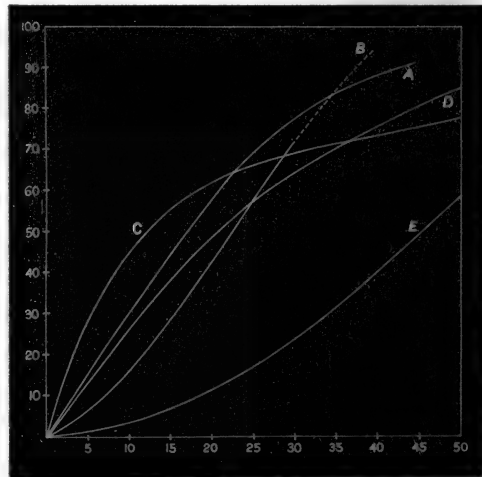

FIG. 1.

The work appears to have been executed with the skill and thoroughness which would naturally be expected of the author, and will doubtless prove of great service to those engaged upon these matters. The scanty reference to previous knowledge, which Prof. Langley holds out some promise of extending in subsequent publications, makes it rather difficult to pick out the points of greatest novelty. The main problem is, of course, the law of obliquity, and this is attacked with two distinct forms of apparatus. The general character of the results, exhibited graphically on p. 62, will be made apparent from the accompanying reproduction, in which are added a curve D,

<sup>1</sup> We are indebted to *Industries and the Electrician* for some of the illustrations used in this article.  
<sup>2</sup> "Experiments in Aerodynamics." By S. P. Langley. "Smithsonian Contributions to Knowledge." (Washington, 1891.)  
<sup>3</sup> "System of Mechanical Philosophy," by John Robison, vol. ii., 1822.

<sup>1</sup> Report of Aeronautical Society for 1866.  
<sup>2</sup> Proc. Inst. Civ. Eng., 1871 (discussion upon a paper by Sir F. Knowles).  
<sup>3</sup> See *Phil. Mag.*, December 1876. Also Basset's "Hydrodynamics," vol. i. p. 231.  
<sup>4</sup> *Phil. Trans.*, 1708.

corresponding to (1), and E, representing the law of  $\sin^2 a$ . In each case the abscissa is the angle  $a$ , and the ordinate is the normal pressure, expressed as a percentage of that experienced when  $a = 90^\circ$ . Of Prof. Langley's curves, A relates to a square plane 12 inches  $\times$  12 inches, B to a rectangle 6  $\times$  24 inches, and C to a rectangle 30  $\times$  4.8 inches, the leading edge (perpendicular to the stream) being in each case specified first, so that the theoretical curve D corresponds most nearly to C. It will be seen at a glance that at small angles the pressure is enormously greater than according to the law of  $\sin^2 a$ . The differences between A, B, C, anticipated in a general manner by Wenham and Froude, are of great interest. They demonstrate that in proportion to area a long narrow wing is more efficient as a support than a short wide one, and that in a very marked degree.

Up to a certain point there is no difficulty in giving a theoretical account of these features. When a rectangular lamina is exposed perpendicularly, there is one point, *i.e.* the centre, at which the velocity of the stream is annulled. At this point the pressure attains the full amount,  $\frac{1}{2}\rho V^2$ , due to the velocity of the stream, while at every other point the pressure is less, and falls to zero at the boundary. If the lamina is sloped to the stream, as in B and C, there is still a median plane of symmetry; and at one point in this plane, but now in advance of the centre, the full pressure is experienced. In strictness, there is only one point of maximum pressure, whatever may be the proportions of the lamina. But if the rectangle be very elongated, there is practically a great difference in this respect according to the manner of presentation, although the small angle  $a$  be preserved unchanged. For when the long edges are perpendicular to the stream (C), the motion is nearly in two dimensions, and the region of nearly maximum pressure extends over most of the length. But the case is obviously quite different when it is the short dimension that is perpendicular to the stream, for then along the greater part of the length there is rapid flow, and consequently small pressure.

It will naturally be asked whether any explanation can be offered of the divergence of C from the theoretical curve D. This is a point well worthy of further experiment. It seems probable that the cause lies in the suction operative, as the result of friction, at the back of the lamina. That the suction is a reality may be proved without much difficulty by using a hollow lamina, AB (Fig. 2), whose interior is connected with a manometer.

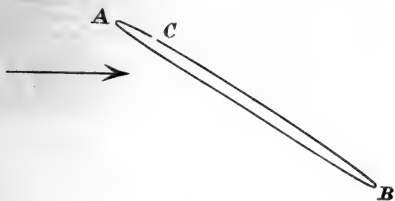

FIG. 2.

If there be a small perforation at any point C, the manometer indicates the pressure, positive or negative, exercised at this point, when the apparatus is exposed to a blast of air.

When once the law of obliquities is known, the problem of aerial maintenance presents no further theoretical difficulty. It was successfully treated many years ago by Penaud,<sup>1</sup> and somewhat later by Froude, whose interesting letters, written shortly before his death, have recently been published.<sup>2</sup> In perhaps the simplest form of the

<sup>1</sup> See Report of Aeronautical Society for 1876.

<sup>2</sup> Edinburgh Proceedings, R. E. Froude, 1891.

question the level is supposed to be maintained with the aid, *e.g.*, of screw propulsion, the necessary maintenance being secured by an acroplane slightly tilted ( $a$ ) upwards in front. The work required to be expended in order to maintain a given weight depends upon the area of plane, the inclination, and the speed. Penaud's results show that, if skin friction could be neglected, the necessary work might be diminished indefinitely, even with a given area of wing. For this purpose, it would only be necessary to increase the speed and correspondingly to diminish  $a$ . But when skin friction is taken into account, the work can only be reduced to a minimum, and to do this with a given area of wing requires a definite (large) velocity, and a definite (small) inclination. The accurate determination of the tangential, as well as of the normal, force experienced by an inclined plane is thus of essential importance in the question of flight.

The work of Penaud seems to be so little known that it has been thought desirable to recapitulate some of his theoretical conclusions. But we owe to Penaud not merely sound theory, but the actual construction of a successful flying machine, in which horizontal flight is maintained by a screw propeller. In these models the energy is stored by means of stretched india-rubber, a method available only upon a small scale. It is probable that the principle of the rocket might be employed with advantage; and even upon a large scale the abolition of all machinery would allow of considerable extravagance in the use of explosive material. This method is especially adapted to the very high speeds which on other grounds are most suitable.

In the chapter on "The Plane Dropper," some striking experiments are described, illustrating the effect of a forward movement in retarding the fall of a horizontal plane. Prof. Langley seems hardly to recognize that there is nothing really distinctive in this arrangement when he says:—

"It is, of course, an entirely familiar observation that we can support an inclined plane by moving it laterally, deriving our support in this case from the upward component of pressure derived from the wind of advance; but, so far as I am aware, this problem of the velocity of fall of a horizontal plane moving horizontally in the air has never been worked out theoretically or determined experimentally, and I believe that the experimental investigation whose results I am now to present is new."

But, apart from the complications which attend the establishment of a uniform régime, there is no essential difference between the two cases. The hydrodynamical forces depend only upon the magnitude of the relative velocity and upon the inclination of this relative velocity to the plane. All else is a question merely of ordinary elementary mechanics.

It is interesting to note that Prof. Langley's experience has led him to take a favourable view of the practicability of flight upon a large scale. Such was also the opinion of Penaud, who (in 1876) expresses his conviction "that, in the future more or less distant, science will construct a light motor that will enable us to solve the problem of aviation." But sufficient maintaining power is not the only requisite; and it is probable that difficulties connected with stability, and with safe alighting at the termination of the adventure, will exercise to the utmost the skill of our inventors.

RAYLEIGH.

#### PRELIMINARY NOTICE OF A NEW BRANCHIATE OLIGOCHÆTE.

THE term "Annélides a branches ségégères," applied by Cuvier to the group which included the terrestrial and fresh-water Annelids, now known as the Oligochæta, is no longer applicable to that group. Several Oligochæta have been described as possessing

gills, which, though for the most part differing in structure from the gills of the Polychæta, must be branchial in function. The most remarkable instance hitherto known is *Alma nilotica*, lately redescribed by Levisen (*Vidensk. Meddel. naturh. For. Kjöbenhavn*, 1889) under the name of *Digitibranchus niloticus*. The posterior segments of this Annelid possess four to five branchial processes on each side of the dorsal middle line of the body. It cannot yet be regarded as an absolute certainty that this species belongs to the Oligochæta at all; but in any case processes of the body-wall, containing each a capillary loop, and therefore probably branchial in function, have been recently described by Prof. A. G. Bourne (*Quart. Journ. Micr. Sci.*, vol. xxxi.) in a new genus of Naidæ—*Chatobranchus*. These processes, though doubtless branchial in function, are rather suggestive of the parapodia of marine Annelids, since they inclose, partially or entirely, the dorsal setæ. I have lately had the opportunity of examining this Annelid, through the kindness of Mr. Sowerby. The "*Victoria regia* tank" at the Botanical Society's Gardens, which produced the celebrated "Fresh-water Medusa" and other remarkable forms, furnished me with *Chatobranchus*, and with a new and interesting form of branchiate Oligochæta, which I propose to call *Branchiura Sowerbii*.

In its general aspect this worm recalls a *Tubifex*; the setæ, in their shape, and in their arrangement, resemble those of *Tubifex*. But here the resemblance ends. The last sixty segments or so of the body (there are from 130-170 segments altogether) are provided with a paired series of long tentacle-like processes—a pair to each segment—lying the middle ventral and dorsal lines; towards the middle of the series these processes exceed in length the diameter of the body; anteriorly and posteriorly they diminish, and finally become mere wart-like protuberances. The processes in question are supplied with blood from the main vascular trunks. They are in continual movement, each branchia moving quite independently by means of the contraction of simple muscular fibres. The writhing movements, as well as the structure of these organs, is much like that of the tentacles and cirri of certain Polychæta. Apart from the individual contractions of these branchiæ, the tail end of the worm perpetually jerks from side to side, particularly when the creature is in any way disturbed. I do not know whether the worm usually rests in the mud with the tail protruding and waving about, like many other aquatic Oligochæta; but it is probable, from the limitation of the branchiæ to the tail end, that it does. I found three specimens, which were slowly crawling about.

FRANK E. BEDDARD.

#### THE ANNIVERSARY OF THE ROYAL SOCIETY.

MONDAY being St. Andrew's Day, the anniversary meeting of the Royal Society was held in their apartments in Burlington House. The report of the auditors of the Treasurer's accounts having been read, and the Secretary having read the list of those Fellows who have been elected and those who have died since the last anniversary, the President, Sir William Thomson, delivered the anniversary address. After an account of the scientific work of those Fellows who had died within the year, the President proceeded:—

"The Royal Society, since the last anniversary meeting, has been, as always, active both in the proceedings of its ordinary meetings, which have been full of scientific interest, and in the conduct of the important affairs committed to its Council. During the past year nineteen memoirs have been published in the Philosophical Transactions, containing a total of 1020 pages and 60 plates. Of the Proceedings, six numbers have been issued, containing 893 pages. Of the large

number of papers which have been published in the Proceedings two-thirds are on the physics and dynamics of dead matter and one-third on biological subjects.

"As stated by Sir George Stokes in his Presidential Address at the last anniversary meeting, a revision of the whole body of the Statutes of the Royal Society had been entered upon, a Committee had recently reported to the Council, and its report had been left to the new Council then entering on office to take such action in the matter as might be judged proper. The Council now concluding its term of office has accordingly given much time to the subject, and has completed the work of re-enacting the Statutes with such amendments as have seemed desirable. The only questions upon which there was effective difference of opinion were those connected with the election of Fellows, which were referred to by Sir George Stokes as having elicited considerable difference of opinion in the reporting Committee. The Council, after much anxious consideration, resolved to make no change of the existing Statutes in this respect.

"There have been no changes during the past session in the constitution of the staff employed in the Offices and Library; but in the Catalogue Department, two lady assistants and two copyists have been engaged to work under the superintendence of Miss Chambers, who succeeded in July of last year to the post rendered vacant by the death of the late Mr. Holt, and who continues to give every satisfaction in the discharge of her duties.

"In January of the present year a communication was received from our Fellow, Prof. G. S. Brady, intimating that his brother, the late Mr. Henry Bowman Brady, whose decease I have already mentioned, had bequeathed to the Society all his books and papers relating to the Protozoa, with the recommendation that they should be kept together as a distinct collection. In case this recommendation should be adopted, a further bequest of £300 was made, the interest or principal or both to be applied, at the discretion of the Council, to the purchase of works on the same or kindred subjects, to be added to the collection. The Council have accepted both these bequests, and a case marked with an engraved plate has been set aside in the Library for the accommodation of the Brady collection.

"His Excellency Robert Halliday Gunning, M.D., LL.D., F.R.S.E., who in 1837 founded certain scholarships and prizes for the promotion of original scientific work and proficiency in scientific education in connection with the Royal Society of Edinburgh, the University of Edinburgh, and other institutions in that city, called the Victoria Jubilee Prizes, desires to institute foundations of a similar kind in London. He has accordingly given to the Royal Society a sum of £1000, to be ultimately invested in such manner as the President and Council, in their absolute and uncontrolled discretion, may think fit, and to be held in trust always for the purpose of forming a fund the annual income of which shall be applied triennially towards the promotion of physical science and biology in such manner as to the President and Council of the Royal Society may appear most desirable. The President and Council, for the time being, are given full power to make such rules and regulations as they think fit with regard to the application of the income of the fund, which shall always be kept distinct from and not in any way immixed with the general funds of the Royal Society.

"A very important resolution for the advancement of natural knowledge has been adopted during the past year by the Royal Commissioners of the Exhibition of 1851, in the institution of the Exhibition Science Scholarships, to which, after the first year, an expenditure to the extent of £5000 a year is to be devoted. Sixteen appointments have already been made to scholarships of £150, to be held for two years, with possible renewal for a third year. The Commissioners require of each candidate for an appointment satisfactory evidence of proficiency in a three years' course of University or high class College study, and of capacity for experimental work. To the tenure of each scholarship the duty is assigned of advancing science by experimental work in physics, mechanics, chemistry, or any application of science tending to benefit our national industries.

"A Committee of the British Association, appointed for the purpose of reporting on the best means of comparing and reducing observations on terrestrial magnetism, has strongly recommended the re-establishment of a magnetic Observatory at the Cape of Good Hope. A conference on the subject was held between the Committee and Dr. Gill, the Astronomer-Royal of the Cape of Good Hope, last June, during his recent visit to



England, which has resulted in an application to the Admiralty to carry this recommendation into practical effect in connection with the astronomical Observatory of the Cape of Good Hope (belonging to the Admiralty). This application is at present under the consideration of the Admiralty.

"A fundamental investigation in astronomy, of great importance in respect to the primary observational work of astronomical Observatories, and of exceeding interest in connection with tidal, meteorological, and geological observations and speculations, has been definitively entered upon during the past year, and has already given substantial results of a most promising character. The International Geodetic Union, at its last meeting in the autumn of 1890, on the motion of Prof. Foerster, of Berlin, resolved to send an astronomical expedition to Honolulu, which is within 9° of the opposite meridian to Berlin (171° west from Berlin), for the purpose of making a twelve months' series of observations on latitude corresponding to twelve months' analogous observations to be made in the Royal Observatory, Berlin. Accordingly, Dr. Marcuse went from Berlin, and, along with Mr. Preston, sent by the Coast and Geodetic Survey Department of the United States, began making latitude observations in Honolulu about the beginning of June. In a letter from Prof. Foerster, received a few weeks ago, he tells me that he has already received from Honolulu a first instalment of several hundred determinations of latitude, made during a first three months of the proposed year of observations; and that, in comparing these results with the corresponding results of the Berlin Observatory, he finds beyond doubt that in these three months the latitude increased in Berlin by one-third of a second, and decreased in Honolulu by almost exactly the same amount. Thus, we have decisive demonstration that motion, relatively to the earth, of the earth's instantaneous axis of rotation is the cause of variations of latitude which had been observed in Berlin, Greenwich, and other great Observatories, and which could not be wholly attributed to errors of observation. This, Prof. Foerster remarks, gives observational proof of a dynamical conclusion contained in my Presidential Address to Section A of the British Association at Glasgow, in 1876, to the effect that irregular movements of the earth's axis to the extent of half a second may be produced by the temporary changes of sea-level due to meteorological causes.

"It is proposed that four permanent stations for regular and continued observations of latitude, at places of approximately equal latitude, and on meridians approximately 90° apart, should be established under the auspices of the International Geodetic Union. The reason for this is that a change in the instantaneous axis of rotation in the direction perpendicular to the meridian of any one place would not alter its latitude, but would alter the latitude of a place 90° from it in longitude by an amount equal to the angular change of the position of the axis. Thus two stations in meridians differing by 90° would theoretically suffice, by observations of latitude, to determine the changes in the position of the instantaneous axis; but differential results, such as those already obtained between Berlin and Honolulu, differing by approximately 180° in longitude, are necessary for eliminating errors of observation sufficiently to give satisfactory and useful results. It is to be hoped that England, and all other great nations in which science is cultivated, will co-operate with the International Geodetic Union in this important work."

The celebration of the hundredth anniversary of the birth of Faraday, recorded in our columns at the time, was next referred to.

"A matter of great importance in respect to the health of the community was submitted to the Royal Society by the London County Council, in a letter of date May 1, 1891, asking for information and suggesting investigation regarding the vitality of microscopic pathogenic organisms in large bodies of water, such as rivers which are sources of water-supply and which are exposed to contamination. After some correspondence, it was agreed, between the County Council and the Council of the Royal Society, to enter upon an investigation, the expense of which was to be defrayed partly by the London County Council and partly by the Royal Society out of the Government Grant for Scientific Research. When we consider how much of disease and death is due to contaminated water, we must feel that it is scarcely possible to over-estimate the vital importance of the proposed investigation. Let us hope that the alliance between the London

County Council and the Royal Society, for this great work, may be successful in bringing out practically useful results.

*Prof. Stanislao Cannizzaro (Copley Medal).*

"Stanislao Cannizzaro, Senator of Italy, and Professor of Chemistry in the University of Rome, has rendered invaluable service to the philosophy of modern chemical science. The work of Avogadro, in 1811, and afterwards that of Ampere, had already thrown much light on the relative weights of the molecules of elementary bodies, and on the proportion in which those weights enter into chemical combination. But it is to Cannizzaro that we owe the completion of what they had left unfinished. He pointed out the all-important difference, hitherto overlooked, between molecular and atomic weights, and showed (1) how the atomic weights of the elements contained in a volatile compound can be deduced from the molecular weights of such compounds; (2) how the atomic weights of the elements the vapour-densities of whose compounds were unknown can be ascertained by help of their specific heats. By these investigations the series of atomic weights of the elements, the most important of all chemical constants, and the relation which these weights bear to the molecular weights of the elements, have been placed on the firm basis on which they have ever since rested. It is to Cannizzaro that science is indebted for this fundamental discovery, and it is this which it is proposed to recognize by the award of the Copley Medal.

*Prof. Charles Lapworth, F.R.S. (Royal Medal).*

"Prof. Lapworth is the author of some of the most original and suggestive papers which have appeared in the geological literature of this country for the last twenty years. Special reference may be made to his researches on graptolites, and to his patient investigation by these means of the exceedingly complicated structure of the Silurian uplands of the south of Scotland. He has been able not only to supply the key which has given the solution of the stratigraphical difficulties of that region, but also to furnish theoretical geology with an array of new facts from which to philosophize as to the mechanism of mountain-making. Of not less importance are his detailed studies of the structure of the North-west Highlands, and his demonstration of the true order of stratigraphical sequence in that region of complex disturbance. As a stratigraphist he has attained the highest rank, and he has likewise made himself a chief palæontological authority on the structure and distribution of the Graptolitidae. For some years past he has been engaged in a laborious study of the Silurian and Cambrian rocks of the middle of England, the detailed publication of which is awaited with much interest by geologists.

*Prof. Rücker, F.R.S. (Royal Medal).*

"In conjunction with Prof. Reinold, Prof. Rücker carried out an important series of researches (extending over ten years) on the electric resistance and other physical properties of liquid films, in the course of which the fact was established that the black part of a soap film in equilibrium has a uniform or nearly uniform thickness of 11 or 12 micromillimetres, and that there is an abrupt augmentation across its border to a thickness of about 30 or 40 micromillimetres in passing to the coloured portions. This, considered in connection with the well-known sudden opening out of the little black areas in an ordinary soap-bubble, proves a minimum of surface-tension for some thickness between 10 and 50 micromillimetres, which in the ordinary soap-bubble, unmodified by Reinold and Rücker's electric current, is temporarily balanced in virtue of the abrupt change of thickness, a proposition of fundamental importance in the molecular theory, implying the existence of molecular heterogeneity.

"In theoretical calculations connected with the co-compounding of dynamos and motors to produce constant potential difference, constant current, or constant speed, electricians did not see their way to obtain results of a sufficiently simple character to be of use in practice, if they employed a function of the current which fairly represented the magnetism. They were, therefore, compelled to assume in such calculations that the magnetism was a linear function of the current, although it was well known that this was very far from being true when the current was large. Prof. Rücker, however, developed a simple method of attacking such problems, and showed how the magnetic saturation of the iron might be taken into account, and a comprehensive solution of the general problem of compounding dynamos and motors obtained in a workable form. Prof. Rücker's paper containing

his investigation, and which will be found in the Proceedings of the Physical Society, is a most valuable contribution to the theory of direct-current dynamos and motors.

"Prof. Rücker has, with the co-operation of Prof. Thorpe, completed a magnetic survey of the British Isles (1884-89), which, independently of its great value in investigations of the distribution of the earth's magnetism, and the changes to which it is subject, is specially remarkable for the exhaustive discussion of the observations in reference to regions of local magnetic disturbance, and their relation to the geological constitution of the earth's crust in the neighbourhood. Prof. Rücker has followed up this discussion by a paper on 'The Relation between the Magnetic Permeability of Rocks and Regional Magnetic Disturbances,' read before the Royal Society. The high estimate that has been formed of the value of this magnetic survey is perhaps most easily appreciated from the very large sums that the Government Grant Committee have recommended should be contributed to aid in the completion of this work of international importance.

*Prof. Victor Meyer (Davy Medal).*

"Prof. Victor Meyer, formerly the successor of Wöhler at Göttingen, and who now occupies the chair of Bunsen at Heidelberg, is eminent as an original worker and discoverer in almost every branch of chemical science. His methods of determining the vapour-densities of substances have been of the greatest service to chemists, not only as convenient and generally applicable modes of ascertaining atomic and molecular weights, but also as serving to throw light on the molecular constitution of elements and compounds under varying conditions of temperature and pressure. A striking example of the value of these methods is seen in their application by their author to the study of the molecular dissociation of the element iodine—one of the most masterly investigations of recent years, and which is universally recognized as of the very highest significance and importance. Not less noteworthy are Victor Meyer's services to organic chemistry. His work on the nitroso-bodies, and his brilliant discovery of thiophene, the initial member of a class of substances hitherto unknown, his subsequent synthetical formation of it, and the remarkable series of researches on its derivatives, in part carried out with the aid of his pupils, stamp him as an investigator of exceptional power and distinction."

The Society next proceeded to elect the Officers and Council for the ensuing year. The following is a list of those elected:—President: Sir William Thomson. Treasurer: John Evans. Secretaries: Prof. Michael Foster, The Lord Rayleigh. Foreign Secretary: Sir Archibald Geikie. Other Members of the Council: Captain William de Wiveleslie Abney, William Thomas Blanford, Prof. Alexander Crum Brown, Prof. George Carey Foster, James Whitbread Lee Glaisher, Frederick Ducane Godman, John Hopkinson, Prof. George Downing Livinge, Prof. Joseph Norman Lockyer, Prof. Arthur Milnes Marshall, Philip Henry Pye-Smith, William Chandler Roberts-Austen, Prof. Edward Albert Schäfer, Sir George Gabriel Stokes, Bart., Prof. Sydney Howard Vines, General James Thomas Walker.

In the evening the Fellows and their friends dined together at the Whitehall Rooms, Hôtel Métropole. The company numbered over 230. The chair was occupied by the President.

After the loyal toasts, Dr. John Evans proposed "Her Majesty's Ministers and the Members of the Legislature," a toast to which Sir J. Fergusson responded.

In response to "The Royal Society," proposed by Mr. Forwood, M.P. (who referred to the fact that Sir William Thomson's discoveries "had rendered it possible to steer vessels on our fog-bound coast with an accuracy never before attained to"), the President said that the Royal Society had always been distinguished for the promotion of investigations leading to such results as Mr. Forwood had named. In illustrating this, he spoke of the history of the construction of the sextant and the development of the dynamical theory of the trade winds. A curious interest attached to some of the earlier Transactions of the Society, such as a paper which attributed the trade

winds to the breathing of a certain plant, which turned to the sun and blew its breath after it. The earlier pages of the Transactions were full of chronometers and of the work leading up to the invention which gained the reward of £10,000. Excellent work was done with the grant of £4000 administered by this and allied Societies; and he believed its future achievements would at least equal those of the past. The next fifty years would probably produce, in the science of dead matter, and in the science of living matter too, discoveries compared with which those of the last 300 years would ultimately appear to be small indeed.

The President proposed the health of "The Medalists," and spoke in eulogistic terms of the services in respect of which the medals had been awarded.

The Italian Ambassador briefly responded in the name of Prof. Stanislao Cannizzaro.

Prof. Rücker, in responding for the other medalists, said:—

Islanders as we were, the Royal Society prided itself on the fact that some of its medals could be awarded to distinguished scientific workers outside these islands. This year no less than four foreign Fellowships and two medals testified to our respect and esteem for colleagues abroad. We respected them for many things—for the thoroughness with which they grasped all that the scientific movement meant and involved; for the foresight and courage with which—beginning at the beginning—they had provided for their students laboratories and workshops such as no English lad could enter at home. We respected them for the sound educational methods which had led them to use these appliances, so as to point the student to the research laboratory rather than to the examination room as the goal of his ambition. We respected them because these methods have produced their natural results, and year by year a crop of new scientific facts was reaped not only from the laboratories of their Colleges, but from the workshops of their manufacturers. We respected and esteemed most of all the men who had thus led or who were thus leading their countrymen aright—veterans, such as Cannizzaro, who, amid the turmoil in which the foundations of modern Italy were laid, found time to lay the foundations of chemistry anew; investigators, such as Victor Meyer, who, when Bunsen retired from the laboratory where so many English chemists learnt or perfected their art, was judged by all to be a worthy successor to Bunsen himself. While fully admitting that we had something to learn from the work and methods of our foreign colleagues, we might claim that our progress had lately quickened where at one time we notoriously lagged behind. In the multiplication of centres of scientific work, Scotland was formerly the only part of these islands which compared with Germany. This was no longer so. Every large town in England and Wales and the chief towns of Ireland had now University Colleges. Their scale was modest indeed when compared with what a paternal Government was providing for Strasburg, or a democracy for Zürich; but they were full of intellectual energy and of scientific work. Hardly a month passed without the publication of papers on researches conducted in the laboratories of some of them. Almost every year they were represented in the list of Fellows newly elected into the Society. Out of the last eight recipients of the Royal Medals, five had, either as learners or as teachers, or, in turn, in both capacities, spent many years within the walls of one or other of our provincial Colleges. But he must not be understood as claiming for English science only that it was making good confessed educational deficiencies. There were sciences which, either in their origin or their development, were peculiarly our own. One of these was geology. Crowded up between our four seas was an epitome of the past history of the world such as he believed no other country possessed in an equally small area. Thus geologists were a natural product of our soil. But there was one particular in which he thought the President, more than most, would appreciate Prof. Lapworth's audacity and success. Though a Southerner, he had made a foray into Scotland, and had returned laden with spoil. It was true that he, too, had crossed the border, and he deeply regretted that he must confess that his track was marked by disturbances: but speaking for Prof. Lapworth and on his behalf—though without consulting him—he must admit that his offences were venial and that he was most to blame. He turned the most fundamental institution

of Scotland—its geological strata—upside down. There were only two ways of meeting an invader or an innovator such as this—with steel or with gold. They must confute him with the pen or reward him with a medal. The Council had chosen the better part of valour, and he was sure the Society did not question their discretion. With regard to himself, there was one remark that he must make. In some of the principal researches in which he had been engaged he had worked with colleagues. While, therefore, thanking the Society for the honour they had been pleased to confer upon him, he was, perhaps, not wrong in thinking that Dr. Thorpe and Prof. Reinold, who had received many marks of appreciation from the Royal, the Physical, and the Chemical Societies, were receiving further, though less direct, recognition from the Royal Society to-day. Apart from all minor questions, the distinguishing characteristic of this meeting was the bringing together of men who were working at different branches of science. These gatherings, and those which in the summer take place during the meetings of the British Association, were, he thought, good for all of them. They checked that scientific particularism which in the cultivation of a subject of study ignored the culture of the student. They reminded them that they were all co-operating to one common end—the promotion of natural knowledge. The very speech that he was making bore testimony to this fact, for were it otherwise the President would not have called upon an Englishman to reply for our absent foreign metallists, or a physicist to return thanks for honours bestowed on experts in geology and chemistry. It was only because he himself believed that there was between scientific men a similarity of aim and object, and a community of ideas, which underlay all superficial differences, that he ventured to undertake the task of expressing the thanks in which, he was sure, one and all of the metallists most heartily joined.

Prof. Dyer proposed "The Visitors," associating with the toast the name of the Greek Minister. He said:—

The association appeared to him a peculiarly happy one. The other day he came across a striking statement of Sir Henry Maine's—"Except the blind forces of Nature, nothing moves in this world which is not Greek in its origin." The former influence they could in this Society give some account of. But the latter he regarded with a certain scientific scepticism. Yet he was not disposed to dispute its validity. We still commenced our often arduous mathematical studies with Greek geometry, and he could not gainsay those who thought that the influence of the counsels of Plato, and of the precepts of Aristotle, was unexhausted. In art Greece remained unsurpassed and unsurpassable. Some might say that if scientific men had their way they would extinguish Greek studies. This was far from the truth. In this Society they rejoiced in those exact studies which recreated the literature and life of the past.

The Greek Minister, in replying, said:—

He had always been of opinion that those who were entrusted with the duty of representing their respective Governments in this country, need confine their watchfulness and activity neither to political nor to social circles alone. They had before them a wide and unrivalled field in which to study the benefits accruing to a whole community—to the Government itself—from the efforts of private individuals, when guided by public zeal and devotion to science; and he thought no more striking example of such benefits could be instanced than the results of the labours of this, the most ancient and most illustrious of learned Societies. It might be said to have been born with the first dawn of scientific research in England; it had remained its stronghold in times of political trouble and change; it numbered in its long muster roll all those names which had bequeathed an undying fame to British science; it had worked out and solved, for the benefit of the State, scientific questions which were elsewhere delegated to official departments alone; its catalogue of scientific papers was a monument of the world-wide grasp of its subjects. That the achievements of this Society should have been continuous and ever increasing in importance for close upon 250 years was characteristic of British public zeal and tenacity of purpose. But what was especially instructive was the ardour with which such work was prosecuted, not only by those whose pursuit was science, but by those especially who, like the illustrious statesman at the head of Her Majesty's Government, being independ-

ent by fortune and already great by birth and political achievements, yet contributed powerfully to the advancement of science. It was at symposia such as this that the philosophers of ancient Greece laid down those great truths of science which had found amongst this Society such ardent apostles and such illustrious expounders. The guests on whose behalf he responded, and he himself, expressed sincere acknowledgments for the honour they had done them that night.

The company then separated.

#### NOTES.

A MEETING of the honorary council of advice in connection with the Crystal Palace Electrical Exhibition, which is to be opened on January 1 next, was held last week at the Mansion House. The Lord Mayor presided. Mr. Gardner, the secretary of the Crystal Palace Company, read the report of the directors, in which they referred to the Electrical Exhibition at the Palace in 1881, and to the enormous strides which had since been made in the industry. The Exhibition of 1881 was recognized as the pioneer of electrical engineering in this country, and it was confidently believed that the Exhibition of 1892 would be remembered in history "as showing that the infant Electra has grown to years of maturity, and is capable of further aiding science, commerce, and the world at large." The space available had been over-applied for, and every section of the industry would be well represented. Invitations would be issued to public bodies throughout the United Kingdom to visit the Exhibition, where the various systems of electric lighting would be on view, and in this direction alone very great saving of expense to the authorities would be effected, and other advantages must, the directors believed, also accrue. On the motion of Mr. W. H. Preece, the following gentlemen were appointed to act as a committee of experts in connection with the exhibits: Profs. W. Grylls Adams, W. E. Ayrton, W. Crookes, D. E. Hughes, A. B. W. Kennedy, J. Perry, and Silvanus Thompson, Major P. Cardew, Sir J. N. Douglass, Mr. W. B. Esson, Mr. Gisbert Kapp, and Mr. Preece.

ON Friday last a portrait of Sir William Thomson, by Mr. Herkomer, was presented to the University of Glasgow. A number of friends subscribed for it, to signalize Sir William's election to the office of President of the Royal Society. The presentation was made by Mr. Balfour, the Lord Rector of the University, who spoke eloquently of Sir William Thomson's great career as a man of science and an inventor. A replica of the portrait was presented to Lady Thomson.

THE Egyptian Government has asked the Caisse de la Dette for £50,000 from the general reserve fund on behalf of the Antiquities Department. The Cairo correspondent of the *Times* says that before granting so large a sum the Caisse will probably require the appointment of a Commission to study the purposes for which it is to be used. It is hoped that searching investigation will be made into the management of the department generally.

It is expected that Australia will be well represented at the Chicago Exposition. Exhibits connected with education, minerals, forestry, and especially wool are to be sent. About fifty wool growers and wool brokers met lately at Sydney, and decided to despatch a very extensive collective exhibit of wools.

WE have to note a change in the form of the publications issued by the Meteorological Department of India. From January 1 last, the Annual Reports on the Meteorology of India, which have hitherto been issued about fourteen months after the termination of the year to which they referred, have been replaced by a Monthly Weather Review, the first four parts

of which have been received. It is hoped that, when the arrangements are complete, these reports will be published from six to eight weeks after current date. The materials used are the morning observations taken at 136 stations, and afternoon observations taken at 82 stations; and eventually, a monthly summary of rainfall observations will be given for about 2500 stations. The text contains full discussions of the chief features of the weather, under each of the principal elements, illustrated by maps showing the mean distribution of the conditions for the month, and the variations from the mean. The report for January also contains a brief review of the meteorology of the year 1890, in which it is stated that conditions were very abnormal in Upper India, and very favourable for a severe winter in the hill districts, and for abundant rain in the plain districts, while the snowfall in the Kashmir Himalayas and Afghanistan during November and December was abnormally heavy. Temperature was steadily below the average in Northern India, but was excessive in the peninsula.

THE *Abhandlungen* of the Royal Prussian Meteorological Institute (Bd. i., No. 4, 1891) contain the first part of a treatise on the climate of Berlin, referring to rainfall and thunderstorms. Berlin possesses a long series of observations, commencing with the beginning of the eighteenth century, but in this investigation some of the earlier observations have not been used. The subjects treated are of the kind:—(1) The amount of rainfall, the annual mean being given as 23 inches. The extreme values varied from 14.26 inches in 1887 to 30 inches in 1882. The wettest months were June and July, yielding together 24 per cent. of the annual amount. (2) Rain frequency. The average number of days on which more than 0.08 inch fell was 152. The months of greatest rainfall frequency were November and December. (3) Hail and soft hail (*Graupel*). The former occurred on 2 to 3 days and the latter on 3 to 4 days in each year, and mostly in the months May, June, and July. (4) Snow. A Berlin winter numbers on an average 33 snowy days. The distribution according to months is very curious: snow does not occur most frequently in the coldest months; it falls as often in March as in December. It lies on the ground 49 days on an average. (5) Intensity of rainfall. Daily falls of more than 2 inches are quite exceptional, and of 1½ inches are not frequent. The greatest fall was 1.86 inches in 1½ hours. (6) Wet and dry periods. Attention is more particularly given to periods of short duration; wet periods of five or more days are fewer than dry periods of similar length; the former average 7.5 and the latter 13.2 per year. (7) Thunderstorms. Berlin enjoys comparative immunity from thunderstorms, as they occur on an average on only 15 days in the year, about half of them being in June and July. This valuable discussion has been carried out by Prof. G. Hellmann.

THE common type of cyclone weather is sometimes materially altered by orographical conditions. This is the case, e.g., at Turin, as recently shown by Signor Rizzo (in a paper to the Academy there). He cites thirty-three cases in the last twenty-five years, which indicate the general course of the weather when a cyclone passes over Northern or Central Europe. After fall of the barometer, with strong west wind, the sky clears, the temperature rises considerably, and the moisture of the air diminishes. This is explained by the influence of the Alps. The strong west wind is forced up the mountain-range, so that its aqueous vapour is condensed, and falls as rain and snow on the western slopes and summit. After crossing the ridge, it descends, and, having parted with its moisture, appears as a warm dry wind (thus forming an unusual feature in cyclones).

THE temperature of the rivers of Central Europe has been recently investigated by Herr Forster, of the Society of Geographers at Vienna University; the monthly and annual means being obtained from thirty-one stations. He distinguishes (with

reference to river and air temperature) the following types:—(a) Glacier rivers. These are always warmer than the air in winter, and much cooler in summer; on the average of the year, they are about 1° colder. (b) Glacier rivers modified by lakes, and rivers from lakes in general. These are, except in spring, warmer than the air, therefore warmer on the annual average. (c) Mountain rivers. Like glacier rivers, these are warmer in winter and cooler in summer than the air, but the difference, especially in summer, is not nearly so great; so that, on the average of the year, it is approximately 0°. (d) Flat country rivers. Their temperature is, throughout the year, higher than that of the air; and the annual average difference is over 1°. Sometimes a different relation between river and air temperature is found in the upper part of a river and in the lower, and transition-types occur between those above indicated.

THE Bahama Islands are soon to be connected with the general telegraphic system of Great Britain and the world. A submarine cable about 200 miles long will be laid from a point about five miles from Nassau, New Providence, to a point about the same distance from Jupiter Inlet, on the south-east coast of Florida. The cable has been designed for the Government of the colony by Mr. W. H. Preece. It will be insulated with gutta-percha, and is being manufactured by Messrs. W. T. Henley and Co. It will be laid in January or February next by the steamer *Westmeath*, belonging to that firm. As the Western Union Telegraphic Company's Floridian lines do not at present run so far south as Jupiter Inlet, the station at the American terminus of the cable will be in charge of the officers of the United States Weather Bureau, who will transmit the messages to the Western Union Company's system over their private line. Traffic between England and the Bahamas will thus pass through the Atlantic cables.

At a meeting held at Aylesbury on Saturday it was resolved, on the motion of Sir Harry Verney, that it was desirable to establish a County Museum for Bucks, and that an executive committee should be appointed to take the necessary measures. Letters from various eminent men of science were read at the meeting. Prof. Flower, writing from the British Museum, pointed out that a good County Museum, well arranged, neat, and attractive, might be the means of conveying instruction and giving interest and pleasure to thousands, and that money, time, knowledge, and sympathetic care must be expended upon it. Prof. Alfred Newton, of Magdalene College, Cambridge, said that the proposal to establish a Museum for Buckinghamshire had his best wishes. He advocated the founding of a maintenance fund, which should be vested in trustees. Prof. Green, of the University Museum, Oxford, contended that in the proposed Museum care should be taken for the proper selection of objects, the primary end being to illustrate the district in which it existed.

DR. ERMILING contributes to the current number of *Globus* an interesting paper on the Nurhagi of Sardinia. There are said to be more than 3000 of these prehistoric buildings in the island. They are almost all in fertile districts, and are built in groups which are separated from one another by wide and generally barren spaces. According to many archaeologists, the Nurhagi were tombs; but the late Canon Spano, in his "Memoria sopra i Nurhagi di Sardegna," published in 1854, contended that they were dwellings and places of refuge, and this view is accepted by Dr. Ermiling. In a trench closed with asphalt, under the ruins of a Nurhage near Teti, various bronze statuettes, swords, spear-heads, and axes were discovered lately by shepherds. These treasures are now in the museum of M. Gouin, a Frenchman, in Cagliari. Some of the objects have been analyzed, and it has been found that the chemical composition of the bronze statuettes is not the

same as that of the axes. The statuets consist of copper 90.3, tin 7.4, iron 2.1; the axes, of copper 87.4, tin 12.0, lead 0.5, with traces of iron.

In the new number of *Petermann's Mitteilungen* Prof. Vambéry has a valuable paper on the geographical nomenclature of Central Asia. He gives a list of names, his spelling of which may safely be accepted as authoritative. The list is to be extended on some future occasion.

At a recent meeting of the Field Naturalists' Club, Victoria, Mr. C. G. W. Officer read a paper on supposed human footprints on Æolian rocks at Warrnambool. In introducing the subject, Mr. Officer described in detail the formation and nature of the sand dunes, and their connection with the underlying strata, as shown by the similarity of the stone now being quarried there. From an analysis of the stone made by Mr. Avery, of Queen's College, it appears that it contains about 94 per cent. of carbonate of lime. Last December a slab was discovered in one of the quarries bearing impressions which suggested that they were made by human beings. This slab was secured by Mr. Archibald, and placed in the Warrnambool Museum. The determination of the age of the rocks is of importance, and from the evidence of subsidence and elevation which have probably taken place since the impressions were made, Mr. Officer is of opinion that a considerable lapse of time has occurred since the rocks were laid down, and he suggests that the impressions were made by two individuals sitting close together and somewhat obliquely to each other. Mr. J. Dennant, discussing the paper, pointed out that it was necessary to be very guarded in accepting any but the strongest evidence on such questions as those relating to the supposed footprints. Amongst limestone rocks it was well known that mimetic forms were common. In the Æolian rocks of Cape Bridgewater occurred the so-called fossil forest, which the casual observer could hardly be persuaded to believe was an accidental resemblance, and nothing more. At the same time Mr. Dennant congratulated Mr. Officer on having produced an interesting and highly suggestive paper. The rocks were well described, and whether his conclusions concerning the impressions were accepted or not, he had succeeded in drawing renewed attention to one of the most striking formations in Victoria.

MR. J. B. TYRRELL, Ottawa, of the Canadian Geological Survey, has spent the last two summers in examining the shores of Lake Winnipeg, Winnipegosis, and Manitoba; and he has issued a few notes on his observations, in advance of a more detailed report to the Survey. Speaking of striation, Mr. Tyrrell refers to many distinct and characteristic glacial striae which show that during the Ice Age a great glacier, or lobe of the Laurentide glacier, moved south-south-eastward across the lacustral plains of Manitoba, along the valley of Red River to the height of land, and onward to near Des Moines, Iowa, sending off branches up the valleys of Swan and Red Deer rivers. The total length of this glacier or lobe, from the north end of Lake Winnipeg to its extreme southern limit in Iowa, would be about 850 miles. With reference to moraines, Mr. Tyrrell says the highest at present known in Northern Manitoba are those capping the summits of portions of the Duck and Riding Mountains, with altitudes of 2500 to 2700 feet above the sea, or 1800 to 2000 feet above the surface of Lake Winnipeg. On the shores and islands of Lake Winnipeg a distinct moraine has lately been recognized. In a section on shore lines Mr. Tyrrell describes Kettle Hill, on the south side of Swan Lake, as one of the most interesting monuments of ancient shore phenomena in the whole district. Swan Lake has an estimated elevation of 27 feet above Lake Winnipegosis, or 855 feet above the sea; and the hill, which appears to have been largely composed of Dakota sandstone, rises 275 feet above it. On the face of this

hill are five distinct terraces, representing six different shore lines, at elevations of 920, 955, 995, 1015, 1070 feet above the sea, those at 955, 995, and 1070 being most strongly marked, the last being the most distinct.

MR. D. MORRIS, Assistant Director of the Royal Gardens, Kew, lately sent to the *Entomologist's Monthly Magazine* for identification specimens of a Coccid, supposed by him to be *Icerya purchasi*, received from St. Helena. They were found there on some rose bushes which had been imported from the Cape of Good Hope. In a note in the new number of the *Entomologist's Monthly Magazine*, Mr. J. W. Douglas says there is no least doubt that the specimens received are females of *Icerya purchasi*; and he adds that if the brood of which they are samples be not extirpated at once by burning all the plants on which they exist, so as to destroy all eggs and young larvae, they will form the beginning of a pest that must be intensely serious in such a small island. The probability is that they were introduced as eggs or larvae, and so escaped observation.

THE fourth volume of the entomological publication issued by the Russian Grand-Duke Nicholas, under the title of "Mémoires sur les Lépidoptères, rédigés par N. M. Romanoff," contains a very valuable work by M. Gr. Grum-Grshimailo—"Le Pamir et sa Faune lépidoptérologique," with twenty-one coloured plates and a map of the Pamir. Besides its special entomological part, the work contains some interesting deductions concerning the geological history of the Pamir. The author came to the conclusion, confirmed afterwards on geological grounds by Prof. Mushketoff, that during the Miocene period the Pamir plateau and Tibet formed a continent which rose isolated above the great Tertiary sea. It was separated at that time from the Tian-Shan Mountains, but seems to have been connected with the Altai Mountains, probably through the Bei-Shan highlands. The hypothesis seems probable on orographical grounds as well—the Pamir and the Altai Mountains belonging to the great plateau of Asia of which the Great Altai is one of the border ridges, while the Tian-Shan belongs to the series of ridges parallel to the border ridges, and is separated from them by deep valleys, which must have been filled by the waters of a Tertiary sea. The same structure may be observed in East Siberia also.

LISTS of the Macro-Lepidoptera and birds of Winchester and the vicinity have been compiled by members of the Winchester College Natural History Society, and have now been published together in the form of a pamphlet. The compilers have evidently taken great care to be accurate, and their work cannot fail to be of service to students of natural history in the locality. Mr. A. W. S. Fisher, who signs the preface to the list of Lepidoptera, points out that it contains 425 species, which have all occurred within six miles of Winchester College. Mr. S. A. Davies, in the list of birds, indicates by an asterisk the cases in which the birds recorded have been bred within a radius of a quarter of a mile of the College. In most cases, Mr. Davies himself has found the nest within the last three years.

ACCORDING to Hering's views, the optical stimulation-value, or "valence," of a coloured radiation, is made up of one white and one or two colour valences (the greater the former, the less the saturation). And he has sought to measure the white valences; one useful means lying in the fact that to an eye kept long in the dark all coloured rays of a certain low intensity seem colourless, but of very different brightness. Hering has lately had an opportunity of taking measurements on a person having sight, but totally blind to colours (a very rare case). This was a music-teacher, twenty years of age. The experiments (described in *Pflüger's Archiv*) brought out the fact that

the spectrum of the totally colour-blind is considerably shortened; in this case it began about  $665 \mu$ , and ceased about  $420 \mu$ . The greatest intensity was in the green. Further, it appeared that all coloured radiations had the same relations of brightness to each other for the adapted normal eye as for the eye of the colour-blind person. With any two spectral lights, again, an equality of sensation could be produced in this person, when a suitable ratio of intensities was established; and when the two different colours, which seemed equal to the colour-blind, were examined with the normal eye (adapted to darkness), it was found that these two colours had equal white valences. In general, the brightness-curve of the spectrum of the colour-blind had the same course as the curve of white valences for the normal eye. These facts are regarded as a strong confirmation of the author's views.

THE Morgue in Paris now has a medico-legal institute attached to it, with courses of lectures, &c. The need of frigorific apparatus has been long felt, and in a recent competition for the supply of it, the arrangement proposed by MM. Mignon and Rouart (Carré's system) has been selected by a Committee, and will be worked out. According to the Report (*Bulletin de la Soc. d'Encouragement*), Prof. Brouardel imposed three conditions: (1) to submit bodies, on arrival, to a temperature of  $-15^{\circ}$  to  $-20^{\circ}$  C. (this on account of bad conductivity and slowness of freezing internally, also the advanced state of decomposition often met with); (2) to take them into a room with temperature varying between  $-4^{\circ}$  and  $-1^{\circ}$ ; and (3) to keep ten bodies at a temperature of  $-4^{\circ}$ . Further, vibration was to be avoided, and the air kept still. The method of Carré, it is known, depends on changes in an aqueous solution of ammoniacal gas, the gas being driven off by heat, liquefied by its pressure, vaporized, and absorbed by water. Chloride of calcium is used to transmit the cold; this liquid passing through pipes in the wooden walls of a freezing cell, into which the body is pushed on a carriage. Ten hours is enough for the largest body: it becomes hard as wood. The after-process is easier. Bodies can be kept thus more than eight months, though decomposition had begun before freezing. When an autopsy is to be made, the body is put into a case which is heated with gas burners, and afterwards it may be relegated to the frozen state to be kept longer. To keep bodies at  $-2^{\circ}$  in a hall, for exhibition to the public, presented special difficulties. How these were overcome may be learned from the above-mentioned Report.

THE new number of the Journal of the Marine Biological Association of the United Kingdom (new series, vol. ii., No. 2) opens with the Council's report for 1890-91 and the Director's report. The weather was extremely unfavourable for continuous and systematic dredging; nevertheless the boats of the Laboratory were constantly employed on every suitable day, and a considerable amount of material was collected. The preservation of specimens has been much more carefully attended to than formerly. One man now devotes almost his entire time to this work. The following are the other contents of the present number:—The egg and larva of *Callionymus lyra*, by J. T. Cunningham (with plate v.); experiments on the production of artificial baits, by Frank Hughes; the rate of growth of some sea fishes and their distribution at different ages, by J. T. Cunningham; on some Ascidians from the Isle of Wight—a study in variation and nomenclature, by Walter Garstang (with plates vi. and vii.); on the development of *Palinurus vulgaris*, the rock lobster or sea crayfish, by J. T. Cunningham (with plates viii. and ix.); the reproduction and growth of the pilchard, by J. T. Cunningham (with plate x.); the distribution of *Crystallogobius nilssonii*, by J. T. Cunningham; physical investigations, preliminary paper, by H. N. Dickson (with plate xi.); notes on meteorological observations at Plymouth, by H. N. Dickson; notes on the herring, long-line, and pilchard

fisheries of Plymouth (continued), by William Roach, Associate Member; note on a British Cephalopod—*Melice oblane* (Ball), by William E. Hoyle; notes and memoranda.

PROF. KAUFMANN, of Liège, has issued a useful "Student" Guide" to the Liège School of Mines and Engineering, the Montefiore Electro-technical Institute, and the principal engineering firms in Liège and the environs. He quotes from an official report by Mr. Vice-Consul Menzies a statement to the effect that the advantages offered by Liège from an educational point of view do not seem to be duly appreciated in the United Kingdom. While the youth of almost all the other European nations are fairly, and in some instances largely, represented at the Liège University, the British students rarely number more than five or six at a time, and sometimes not even that.

A "Handy List of Books on Mines and Mining" has been compiled and published by Mr. H. E. Haferkorn, of the Milwaukee Public Library. He describes it as an alphabetical reference catalogue, arranged under authors and subjects, and including analytical references to the contents of important works.

MESSRS. WHITTAKER AND CO. have issued the fourth edition of the "Working and Management of an English Railway," by George Finlay. In June 1890 the author read a paper at the Royal United Service Institution, on the transport of troops by rail within the United Kingdom. The substance of this paper he has embodied in the chapter on railways as a means of defence. To the present edition he has also added, as an appendix, a lecture (with emendations) delivered at the Society of Arts, on modern improvements of facilities in railway travelling.

MESSRS. WHITTAKER AND CO. have in the press a second edition of Dr. A. B. Griffiths's "Treatise on Manures." It is a little more than two years since the work appeared. Fifty pages of new matter have been added.

THE third edition of "Electricity, treated Experimentally for the Use of Schools and Students," by Linnaeus Cumming, has been published by Messrs. Longmans, Green, and Co. The author has made such additions and alterations as seemed necessary to bring the book up to date.

A NEW edition of Prof. A. Humboldt Sexton's "Elementary Inorganic Chemistry" (Blackie and Son) has been issued. To meet the alterations in the syllabus of the Science and Art Department, the author has recast the part dealing with qualitative analysis.

THE American Association for the Advancement of Science has just issued the Proceedings of its meeting (the thirty-ninth) held at Indianapolis, Indiana, in August 1890.

PART 38 of Cassell's "New Popular Educator" has been published. Besides the illustrations in the text, it includes a good map of Spain and Portugal.

THE second series of lectures given by the Sunday Lecture Society begins on Sunday afternoon, December 6, in St. George's Hall, Langham Place, at 4 p.m., when Mr. Eric S. Bruce will lecture on "Fogs and their Prevention." Lectures will subsequently be given by Prof. J. F. Blake, Prof. Vivian B. Lewes, Prof. Percy Frankland, F.R.S., Dr. Benjamin W. Richardson, F.R.S., Mr. Whitworth Wallis, and Mr. Willmott Dixon.

THE additions to the Zoological Society's Gardens during the past week include a Barbary Mouse (*Mus barbarus*) from Barbary, a Chinese Blue Magpie (*Cyanopodius cyanus*) from China, two Brown Thrushes (*Turdus leucotelus*) from South America, purchased; a Vulpine Phalanger (*Phalangista vulpina*), born in the Gardens.

## OUR ASTRONOMICAL COLUMN.

**MOTION OF STARS IN THE LINE OF SIGHT.**—In a paper read before the Royal Society in January 1890, Prof. Lockyer described a new method of observing spectra of stars and nebulae which did away with errors due to the collimator of the spectroscopie not being exactly in the optic axis of the telescope owing to the flexure of the telescope tube. It consisted in using a siderostat to reflect the light of the body under observation to a vertical object-glass, whence it was converged on the slit of a fixed spectroscopie. By this means perfect stability can be secured. This method has been utilized by M. Deslandres, of Paris Observatory, for the photographic determination of the displacements of lines in stellar spectra due to motion in the line of sight (*Comptes rendus*, November 23). Comparison spark spectra are taken above and below the spectrum of the star, and the difference of position of the lines common to the star and these spectra afterwards measured. The elements used for comparison are iron, calcium, and hydrogen, and the best results have been obtained with the first of the three. The lines in a spectrum of Sirius, taken on March 3, 1891, in this manner, exhibited a displacement which corresponded to a velocity of recession relative to the earth of 19 kilometres per second. But as the earth's motion towards Sirius at the time of observation was 20·2 kilometres per second, the approach of the star to the sun was 1·2 kilometres per second. The results indicate that considerable advantage is to be gained by the use of the siderostat in the study of the radial motions of stars.

**THE VARIATION OF LATITUDE.**—Some determinations of the latitude of Cambridge, U.S., made in 1884-85 exhibited a progressive variation, from which, however, no inference was drawn at the time. The stars observed were contained between  $-5^{\circ}$  and  $+5^{\circ}$  of declination, but a subsequent discussion based on more northerly stars ( $+5^{\circ}$  to  $+50^{\circ}$ ) gave an exactly corresponding variation in latitude. Mr. S. C. Chandler, in the *Astronomical Journal*, No. 248, gives the results of a recent examination of his values, and from the curve connecting the residuals finds the minimum latitude to have been on September 1, 1884, and the maximum latitude on May 1, 1885, with a range of about  $0''\cdot7$ .

**PHOTOGRAPHY OF THE ECLIPSED MOON.**—During the lunar eclipse of November 15, M. Courty, of Bordeaux Observatory, took four photographs of the moon after it had entered the earth's shadow. The exposure given was about two minutes, and the disk of the moon could be easily traced on the negatives, and on some positives presented with a note by M. Rayet to the Paris Academy on November 23. M. Janssen remarked that by photographing the eclipsed moon and the full moon on the same plate, and determining the times of exposure necessary to obtain both images of equal density, a good idea of the relation of the light intensity in the two cases may be obtained.

### PROPOSALS FOR A SCHEME OF CO-OPERATIVE OBSERVATION OF THE SO-CALLED LUMINOUS CLOUDS.

SINCE 1885 curious cloud formations have been seen on summer nights in both the northern and southern hemispheres, in evident connection with those phenomena which followed the great volcanic eruption at Krakatöa. The intense brightness of these formations, considering the position of the sun, denoted that they were situated very far above the earth's surface. Probably these clouds consisted of erupted particles thrown to a very great height and there illuminated on summer nights by the sun.

These cloud-like formations, commonly called luminous clouds, are extremely interesting, both on account of the extraordinary height at which they have for years been moving above the surface of the earth (more than 80 kilometres) and of the movements themselves. A very important point about these clouds is that they are—so far as we yet know—visible in each hemisphere only in the summer. It is the more important that these phenomena should be carefully and widely observed, since it is believed that they are gradually breaking up, so that probably in a very few years no distinct traces of them may remain (see also O. Jesse on so-called luminous clouds, in the journal *Himmel und Erde*, vol. i. p. 263).

Photographic results of the researches of O. Jesse are given in

Part xl. of the Transactions of the Berlin Academy of Science for 1890, and Part xxvii. for 1891. It is very desirable that such photographs should be taken in as many different localities as possible, because from them we get the surest basis for consideration of the situation and movements of the clouds. But valuable aid may be given by the co-operation of numerous observers in various regions of the earth without the aid of any apparatus.

The principal points upon which stress is to be laid in this inquiry are:—

(1) By what method can the so-called luminous clouds be most surely distinguished from others, especially from the ordinary cirrus cloud?

Clouds or cloud-like formations which after sunset and before sunrise stand out brightly from the dark ground of the heavens, no earthly or unearthly sources of light being present on the horizon, can only produce this effect by means of their own light or else by light which they receive directly or indirectly from the sun or moon below the horizon.

Cloud-like formations which shine at night by their own light have doubtless been formerly observed above the surface of the earth. To these formations belong not only thunder and lightning clouds, but also some polar light and meteoric phenomena.

But the so-called luminous clouds do not belong to the various species of self-luminous clouds, for finer measurements of their light are wanting, besides which the fact that they are only seen within the zone of twilight proves that the sun below the horizon is the principal source of their light.

It is well known that there are clouds within this twilight zone which resemble high mountain peaks, and which in the first stages of twilight shine in the light of the sun, though the latter is below the horizon of the observer. It is easy to determine the relation between the position of the sun below the horizon, and the height of those layers of atmosphere which receive the sun's light and reflect it.

But the laws which govern the whole course of twilight are modified when the distribution of the sunlight-reflecting particles in the atmosphere is altered to any great extent. If, for instance, numerous minute atoms produced by volcanic eruption or by the breaking up of meteoric bodies find their way into those heights above the earth's surface in which usually the gaseous elements of the atmosphere are present in a very scattered form, it may happen that such a layer, which reflects the sunlight very strongly, may curiously alter the course of the twilight.

So long after sunset as the masses of air beneath such a layer receive direct light from the sun and reflect it, the observer will not distinguish any deviation from the usual course of twilight. But as soon as the further sinking of the setting sun gradually deprives the lower layers of air of the direct light, the higher layer of dust still receiving light from the sun stands out in astonishing brightness, the particles of dust having strong reflecting power, thus giving to the close of twilight the curious effect of the sudden appearance of shining clouds on the broad surface of the heavens.

The phenomena of the luminous clouds corresponded when first perceived to the above description. At present they are no longer so strong or so extensive, but only form thin whitish-blue shining veils, similar in form to the so-called cirrus or feather clouds, occupying but a comparatively small part of the floor of the heavens inside the twilight segment, and in our zone mostly near the horizon. Probably, the layers are now so thin that very near and exactly above us they can no longer be seen.

From the above considerations it is clear in what way these clouds differ from those situated nearer to us, and especially from the cirrus clouds floating scarcely more than 13 kilometres above the earth's surface. All these lower clouds appear in the later twilight grey and shadowy on a light ground, because the layers of atmosphere above them are the chief source of the remaining twilight. The luminous clouds differ too in shape and structure from the other kinds of clouds.

We must guard, however, against the error of mistaking cirrus for luminous clouds, when, in exceptional cases, the former look very bright, in consequence of receiving light either directly or indirectly from the moon or other sources. In this case, the question is decided by the relatively high degree of stability in position and form of the very high and distant luminous clouds, as ordinary clouds lie lower and nearer, and show much more rapid changes of position.

(2) When convinced of beholding so-called luminous clouds, to what points shall attention be especially directed, and what simple measurements of place, time, form, &c., shall be carried out in order to aid most usefully in the inquiry?

In answering this question we will first consider those methods of research in which the observer can obtain no instrumental aid, except only a watch, which should be a sufficiently good timekeeper to estimate the time of observation to one minute, when compared with the correct time within eight to twelve hours after the observation.

Such simple observations are the more useful, since it frequently happens that in the well fitted up and prepared stations, observation of the phenomena is prevented by bad weather, or else that the phenomena stretch over too large an extent of the earth's surface to be included in an organized series of observations. The farther the stations are apart, the more valuable are the most simple methods. For instance, in order to get corresponding photographic observations from two stations, 35 kilometres apart, such as Berlin and Nauen, the most rigid exactness, both as to time and place, must be observed.

If, however, observations are taken in East Prussia and in the Rhine province respectively, a from twenty to thirty times larger margin of difference as to time and place can be allowed than in the foregoing case, without in any way lessening the value of the result.

So, if without preparation and instruments to hand an observer believes he beholds luminous clouds, he must not imagine that he can render no service to science by examining them closely, for very possibly the most simple method may, taken in conjunction with other similar observations, prove to be of the greatest service.

It is desirable, too, to look out for luminous clouds at all seasons of the year, though, so far, they have only been seen in summer. In the northern hemisphere they have only been seen from the end of May to the beginning of August, with greatest frequency and brightness in the month of July.

During these weeks, usually two stars are seen simultaneously with the luminous clouds, a star of the first magnitude, Capella, and a star of the same constellation, of the second magnitude,  $\beta$  Aurigæ.

The brighter of the two stars, which is characteristic of summer nights, in the northern horizon, sets towards the end of June soon after eleven, and towards the middle of July before ten, on account of the northerly direction of the meridian, and, in North Germany, at a distance from the horizon of 10 to 12 diameters of the full moon. At almost as great a distance from this bright star, and at a not very different distance from the horizon, the second magnitude star follows towards the west.

By estimating the distances and directions of these two stars, an excellent means is afforded of determining the outlines of a group of luminous clouds. It is only necessary to determine how great the distance of a certain part of the outline of the cloud group is from one or the other star, and in what direction this line lies with regard to one or the other star, or how far the line in question is above or below the prolongation of the connecting line of the two stars. A simple drawing of the course of the outlines and their situation with regard to the two stars is useful, even when it cannot be completed on the spot but must be finished from memory. The time at which the drawing was made should be noted within one half-minute.

If the group of clouds should be so far from the above-mentioned two stars as to make the determinations inexact, it is advisable to determine the outlines of the clouds for a certain time in the following way. Take up a position from which the outlines of houses, trees, &c., can be seen close to the position of the clouds, and fix thus the relative position of these earthly objects to the position of the clouds by a simple drawing, describing the spot from which the observation is made in such a manner that the place occupied by the head of the observer can be found again. The lines drawn from the position of the observer to the outlines of the earthly objects, and the resulting localization of the outline of the clouds in the heavens can then be determined at once by means of simple instruments for measuring angles, or on succeeding nights by the aid of a good star chart.

It is necessary to verify the exact point of time of these observations by comparison of the watch used with the time at a telegraph office, and correction of any errors should be made to the fraction of a minute.

In communicating these observations, the exact place at which they have been made must be accurately described.

Should a complete observation be impossible, owing to the time during which the luminous clouds are visible being too short for careful measurements and drawings or to any other cause, the observer should nevertheless communicate briefly to the Society of Friends of Astronomy and Cosmic Physics that he has seen what he believes from the foregoing considerations to be luminous clouds from a certain place, in a certain direction in the heavens, and within a certain quarter-hour.

The peculiar movements hitherto observed of the clouds in question lead to the suggestion that perhaps a period consisting of several days exists, within which one and the same group of clouds is visible at the same hour from the same place, other conditions of the heavens being favourable. Every communication as to these phenomena will be valuable in the decision of this important point, which it has hitherto been impossible to settle, owing to the uncertainty of the weather and the fewness of the observers.

Those co-operating in our branch of research who are in possession of astronomical, photographic, or other physical apparatus, will of course be able to give more exact details as to place, movement, and constitution of the luminous clouds.

Suggestions for these observations cannot be given so briefly and simply; but for the sake of full and complete agreement between different observers, especially as to the point of time selected for taking photographs and measurements, members of the Society of Friends of Astronomy and Cosmic Physics are invited to communicate with O. Jesse, Steglitz bei Berlin, Albrechtstrasse 30. This course would also be advisable in the close optical examination of the clouds with regard to the peculiar changes in strength of light and the degree and kind of self-luminosity which they perhaps send out together with the reflected sunlight.

In the night from June 25-26 of this year the summer reappearance of the luminous clouds was observed very brightly from Berlin and the neighbourhood.

More detailed particulars on the whole subject of inquiry are contained in a small paper by W. Foerster, which has been sent to all the members of the Society of Friends of Astronomy and Cosmic Physics.

### UNIVERSITY AND EDUCATIONAL INTELLIGENCE.

OXFORD.—Mr. G. C. Inge, Magdalen College, has been appointed to the Studentship offered to the University by the Managing Committee of the British School of Athens, from the Newton Testimonial Fund.

The death is announced of Dr. Evan Evans, Master of Pembroke College, who filled the office of Vice-Chancellor of the University from 1878-82.

Convocation has granted £25 towards the cost of the antiquarian researches at Chester, which are throwing great light upon the obscure period of the military occupation of Britain in the time of Agricola. Prof. Mommsen has appreciated the value of these researches.

At a meeting of the Junior Scientific Club, Mr. A. Colefax, Christ Church, read a paper on the investigation of the change taking place in acidified solutions of sodium thiosulphate. The subject of hypnotism was treated by Mr. E. L. Collis, of Keble; and P. C. Mitchell had an exhibit, and offered some remarks concerning primitive man in the Torquay caves.

The University has published the official Calendar for 1892. The arrangement and information contained differ little from former years. We learn that the number of undergraduate members of the University has increased from 3110 to 3212. The number of matriculations in 1890 were 771, as compared with 787 in the preceding year. The number of B.A. and M.A. degrees is very nearly the same as in 1889.

### SCIENTIFIC SERIALS.

*American Journal of Science*, November 1891.—The solution of vulcanized india-rubber, by Carl Barus. Experiments have been made by the author on the solubility of india-rubber in different solvents at different temperatures. Elastic sheet india-rubber, such as is used for rubber bands and tubing, is not fully soluble in  $CS_2$  at  $100^\circ$  or  $160^\circ$ , but is quite soluble at  $185^\circ$ , and extremely soluble at  $210^\circ$ . It is also easily dissolved by liquids of the paraffin series at  $200^\circ$ . Various other substances



have been used as solvents, and many remarkable results obtained. The importance of the paper may be gathered from the fact that in it is described "a method by which vulcanized india-rubber of any quality or character whatever, as well as the undecomposed or reclaimable part of rubber-waste, may be dissolved or liquefied in a reasonably short time, the solutions possessing any desirable degree of viscosity or diluteness, from which india-rubber may be regained on evaporation of the solvents."—Report of the examination by means of the microscope of specimens of infusorial earths of the Pacific coast of the United States, by Dr. Arthur M. Edwards. Seven new fluviatile fossiliferous deposits from Oregon, California, and Washington are described.—The Tonganoxite meteorite, by E. H. S. Bailey. An analysis of the meteorite gave the percentage composition: Fe 91.18, Ni 7.93, Co 0.39, P 0.10, and a trace of copper. The weight is 23½ lbs., specific gravity 7.45, shape an irregular triangular pyramid 9½ inches long by 6½ inches wide by 4½ inches deep. A fine figure showing numerous pittings on the surface of the meteorite accompanies the paper.—Proposed form of mercurial barometer, by W. J. Waggener.—Colour photography by Lippmann's process, by Charles B. Thwing. The results obtained seem to indicate—(1) that mixed colours may be reproduced with a fair degree of accuracy; (2) that an exposure sufficiently long to give a clear image of the red is quite certain to obliterate the blue by over-exposure; and (3) that an over-exposure may completely reverse the colours, causing the original colours to appear on the reverse, and the complementary colours on the film side of the plate.—New analyses of uraninite, by W. F. Hillebrand. From the analyses it appears that the species may be broadly divided into two groups, one characterized by the presence of rare earths and the almost invariable presence of nitrogen, the other containing little or no nitrogen and no rare earths. Varieties of the former group occur in more or less well defined crystals, whilst members of the latter group are usually devoid of crystalline form.—The Tertiary silicified woods of Eastern Arkansas, by R. Ellsworth Call. The investigation has led to the following conclusions:—(1) The silicified woods of Eastern Arkansas are all of Tertiary age. (2) They are derived from the beds of Eocene clays that underlie the sands and gravels in which they commonly occur. (3) They are silicified lignite; the process of silicification has occurred either while they were still in clays, or most often after they were removed and buried in the sands or gravels. (4) They possess as yet no taxonomic value in determining the relative ages of the members of the Tertiary series.—Occurrence of sulphur, orpiment, and realgar in the Yellowstone National Park, by Walter H. Weed and Louis V. Pirsson.—Mineralogical notes, by L. V. Pirsson. Some specimens of cerussite, hæmatite, and cassiterite, gypsum, and pennine are described.—Peridot dykes in the Portage sandstones, near Ithaca, N.Y., by J. F. Kemp.—A new locality of meteoric iron, with a preliminary notice of the discovery of diamonds in the iron, by A. E. Foote. The existence of black and white diamonds in the meteorite appears to be established by indifference to chemical agents and hardness. Carbon in the form of an iron carbide also occurs with the diamonds. The meteorite was found in Cañon Diablo, Arizona. Three figures accompany the paper.—The South Trap Range of the Keweenaw series, by M. E. Wadsworth.—Geological facts noted on Grand River, Labrador, by Austin Cary.

## SOCIETIES AND ACADEMIES.

LONDON.

**Mathematical Society,** November 12.—Prof. Greenhill, F.R.S., President, in the chair.—The President announced the recent decease of Mr. H. M. Jeffery, F.R.S., who was elected January 14, 1875.—The following gentlemen were elected to serve on the Council for the ensuing session: Prof. Greenhill, F.R.S., President; Dr. J. Larmor, Major P. A. MacMahon, F.R.S., and J. J. Walker, F.R.S., Vice-Presidents; A. B. Kempe, F.R.S., Treasurer; M. Jenkins and R. Tucker, Hon. Secs.; other members, Messrs. A. R. Basset, F.R.S., E. B. Elliott, F.R.S., J. Hammond, C. Leudesdorf, A. E. H. Love, S. Roberts, F.R.S., Drs. A. R. Forsyth, F.R.S., J. W. L. Glaisher, F.R.S., and M. J. M. Hill.—The following communications were made:—On selective and metallic reflection, by A. B. Basset, F.R.S. It is well known that most transparent substances, which produce anomalous dispersion, exercise a strong selective absorption,

and at the same time strongly reflect rays of the same periods as those which they absorb. Thus in fuchsine the order of the colours going up the spectrum is blue, indigo, violet; then there is an absorption band, followed by red, orange, yellow. The experimental laws relating to substances of this class may be summarized as follows: (1) the rays which are most strongly absorbed, when light is transmitted through the substance, are most strongly reflected; (2) when the incident light is plane polarized in any azimuth, the reflected light is elliptically polarized; (3) when sunlight is reflected, the colour of the reflected light, when viewed through a Nicol's prism whose principal section is parallel to the plane of incidence, is different from what it is when viewed by the naked eye. The phenomena of absorption, anomalous dispersion, and the like, have formed the subject of numerous theoretical investigations by German mathematicians. It is not the object of the present paper to propose any new theory upon the subject, but to discuss and extend the theory of von Helmholtz. The theory of von Helmholtz is an elastic-solid theory, which is based upon certain assumptions respecting the mutual reaction of ether and matter. The potential energy of the system may be conceived to consist of three distinct portions, viz.  $W_1$ ,  $W_2$ ,  $W_3$ , of which  $W_1$  is the ordinary expression for the potential energy of an isotropic elastic solid;  $W_2$  is a homogeneous quadratic function of the displacements of the matter; and  $W_3$  is a similar function of the relative displacements of ether and matter, and is supposed to arise from the mutual reaction of ether and matter. Having obtained the expression for the energy of the system, the equations of motion can be at once written down; and it will be found, on integrating them, that the index of refraction,  $\mu$ , of light of period  $\tau$ , is given by the equation—

$$\mu^2 = \frac{\rho}{\rho_0} - \frac{a^2 \tau^2}{4\pi^2 \rho_0} \left\{ 1 + \frac{a^2 k^2 \tau^2}{4\pi^2 \rho_1 (k^2 - \tau^2) - a^2 k^2 \tau^2} \right\} \cdot \cdot (1)$$

In this equation  $\rho$  is the density of the ether when loaded with matter,  $\rho_0$  is the density of the ether *in vacuo*, and  $\rho_1$  is the density of the matter;  $k$  is the free period of the matter vibrations, and  $a$  is a constant depending on the mutual reaction of ether and matter. If we suppose that the value  $\tau_1$  of  $\tau$ , which makes the denominator vanish, corresponds to the double sodium line D of the spectrum, whilst a value  $\tau_2$ , which makes  $\mu = 0$ , corresponds to the hydrogen line F,  $\mu^2$  will be negative when  $\tau$  lies between D and F, and (1) accordingly represents a transparent medium (such as fuchsine) which has a single absorption band in that portion of the spectrum. Moreover, the dispersion is anomalous, since the value of  $\mu$  when  $\tau$  is a little greater than  $\tau_1$ , is much greater than its value when  $\tau$  is a little less than  $\tau_1$ . To explain selective reflection, I have provisionally adopted Sir W. Thomson's hypothesis, that the ether is to be treated as an elastic medium, whose resistance to compression is a negative quantity, whose numerical value is slightly less than  $\frac{1}{3}$ ds of its rigidity. Under these circumstances, the amplitudes of the reflected light will be given by Fresnel's sine and tangent formulæ, according as the incident light is polarized in or perpendicularly to the plane of incidence. When  $\mu^2$  is a negative quantity, these formulæ become complex quantities of the form  $e^{-2\pi i \nu / \lambda}$  and  $e^{2\pi i \nu / \lambda}$ , and this indicates that reflection is total, and is accompanied by a change of phase; moreover, since the changes of phase,  $f_1, f_2$ , are different, according as the incident light is polarized in or perpendicularly to the plane of incidence, it follows that if the former is polarized in any azimuth the reflected light will be elliptically polarized. From these results it appears that the colour of the reflected light is of a greenish yellow when viewed by the naked eye; but when it is viewed through a Nicol, whose principal section lies in the plane of incidence, a considerable portion of the yellow rays are refused transmission by the Nicol, and the light under these circumstances is of a much richer green. Cauchy's formulæ for metallic reflection may be obtained from Fresnel's sine and tangent formulæ, by assuming that  $\mu$  ( $= \sin i / \sin r$ ) is a complex quantity of the form  $R e^{i\alpha}$ ; but the experiments of Jamin, and the calculations of Eisenlohr, show that the real part of  $\mu^2$  must be negative, which requires that  $\alpha$  should lie between  $45^\circ$  and  $90^\circ$ . In fact, for silver, Eisenlohr finds that  $\alpha = 83^\circ$ . Lord Rayleigh, on the other hand, has shown that, if we attempt to explain metallic reflection by introducing a viscous term into the ordinary equations of motion of an elastic solid, physical considerations require that the real part of  $\mu^2$  should be positive; he has also shown that a similar objection lies against attempting to explain metallic reflection on the electro-magnetic theory,

by taking into account the conductivity. If, however, we start with von Helmholtz's theory, and introduce a viscous term into the equations of motion of the matter, it will be found possible for the real part of  $\mu^2$  to be negative, provided the free period of the matter vibrations lies between certain limits. We are thus able to construct a mechanical model of a medium which represents the action of metals upon ethereal waves, and which leads to the same formulæ for the amplitudes of the reflected waves as those given by Cauchy.—The contacts of systems of circles, by A. Larmor.—On a class of automorphic functions, by Prof. W. Burnside.—Note on the identity  $4(x^2 - 1)/(x - 1) = Y^2 \pm z^2$ , by Prof. G. B. Mathews.—On the classification of binodal quartic curves, by H. M. Jeffery, F.R.S.—Researches in the calculus of variations; discriminating conditions in isoperimetrical problems, by E. P. Culverwell.—Note on Clifford's paper "On syzygetic relations among the powers of linear quatics," by Prof. Cayley, F.R.S.—Note on finding the G points of a given circle with respect to a given triangle of reference, by J. Griffiths.

**Linnean Society, November 19.**—Prof. Stewart, President, in the chair.—Mr. S. Jennings exhibited a collection of wild flowers made by him during a recent tour through the Rocky Mountains, California, and Mexico.—Prof. G. B. Howes exhibited some dissections of fish crania made by his pupil Mr. R. H. Burne, in which the parts of the skeleton were so displayed that they might be studied in relation to the rest of the head and to the leading cranial nerves.—Mr. E. F. Cooper exhibited specimens of a new variety of *Potamogeton* from Loughborough, lately described and figured by Mr. Alfred Fryer (*Journ. Bot.*, October 1891).—Mr. A. W. Bennett exhibited and made remarks upon some specimens of *Hydrodictyon utriculatum*, Roth. (*H. reticulatum*, De Toni), and some drawings of anomalous *Cyprripedium* and *Disa*.—Mr. W. Carruthers, F.R.S., gave a graphic account of a recent visit to Sweden in search of original portraits of Linnaeus, and detailed the results of his inquiries. His remarks were illustrated by an exhibition of engravings and photographs.—A paper was then read by Mr. Thomas Hick, on a new fossil plant from the Lower Coal-measures. An interesting discussion followed, in which Mr. Carruthers, Mr. G. Murray, Prof. F. O. Bower, Prof. Marshall Ward, and others took part.

## PARIS.

**Academy of Sciences, November 23.**—M. Duchartre in the chair.—On some manuscripts with figures of historical interest relating to artillery and mechanical arts towards the end of the Middle Ages, by M. Berthelot. Some manuscripts from libraries at Munich, Venice, and Paris have been examined, and appear to be of interest as marking a stage in the development of applied sciences. A few of the mediæval figures are reproduced: one represents a diver in his costume; two others show primitive cannon, and one a small-arm used in the fifteenth century.—Preparation and properties of the phosphides of boron, by M. Henri Moissan. By the use of boron phosphoidite, two boron phosphides may be obtained. The compound PB combines with  $\text{HNO}_3$ ,  $\text{H}_2\text{O}$  with incandescence, and inflames in an atmosphere of chlorine in the cold. The compound  $\text{P}_3\text{B}_3$  is much more stable, and is not acted upon in the cold by these two reagents.—On some variations of the glycolytic power of the blood, and on a new method of experimental production of diabetes, MM. R. Lépine and Barral.—M. A. Potier was elected a member of the Academy in the place of the late M. Edmond Bequerel.—*Résumé* of a verbal report on a note by Prince Tourquistanoff, entitled "Le Calendrier vérificateur," by M. Wolf.—*Résumé* of a verbal report on a note by M. de Cohome, entitled "Le Régleur solaire," by M. Wolf.—Observations of the total eclipse of the moon of November 15, made at Bordeaux Observatory, by M. G. Rayet.—Remarks à propos of the observation of M. Rayet as to the possibility of photographing the moon during a total eclipse, by M. A. Gautier.—Remarks on M. Rayet's communication, by M. J. Janssen.—Researches on the motions of stars in the line of sight made with the Paris Observatory siderostat, by M. Deslandres. (For the last four communications, see Our Astronomical Column.)—Remark on a communication by M. Markoff relative to linear differential equations, by M. Painlevé.—On the flow of liquids in capillary tubes, by M. Albert Colson. The influence of temperature on the rate of flow of viscous liquids is seen from the following comparison of the times in which 5 c.c. of glycerine passed through the tube:—

Temperatures ... 21° ... 100° ... 150° ... 250° ... 265°  
Duration of flow ... 8h. ... 360s. ... 114s. ... 40'5s. ... 33s.  
The same tube passed 5 c.c. of water at 20° in 34 seconds. The author divides the liquids he has experimented upon into two classes, distinguished by being perfectly and imperfectly mobile. Ethers and aldehydes are representatives of the former class, for they appear to obey Graham's law that the duration of flow, or rather the rate of diffusion, is inversely proportional to the square root of the density. The values found for  $\frac{t}{\sqrt{D}}$  in this

class of liquids is practically constant. On the other hand, the liquids imparfaitement mobiles, such as alcohols and benzenes, furnish irregular values.—Mechanical determination of the position of the atoms of hydrogen in organic compounds, by M. G. Hinrichs.—Aniline black in dyeing by the dry method, by M. A. Gautier.—On a cocaine violet, by M. P. Cazeneuve.—On the distribution of saccharine matters in the different parts of the edible *Cape* (*Boletus edulis*, Bull.), by M. Em. Bourquelot.—On the existence of veins of leucite in a Mont Dore basalt, by M. A. Lacroix. Leucite has not before been recognized in any of the volcanic rocks of the central plateau of France. The author fully describes the petrological characters of the specimens he has discovered, and also their peculiar mode of occurrence.—Earthquakes, submarine eruption, and elevation of land at Pantellaria, by M. A. Riccò. Earthquake shocks were felt at Pantellaria on October 14. On October 18, the sea to the west-north-west of the island, at a distance of about 5 kilometres, was seen in violent commotion, and a band of land about 1 kilometre long appeared, from which were ejected masses of heated rock and vapour. On approaching the place of eruption, a large number of dead fishes were found, and it was seen that the band was composed of an immense number of black floating masses of rock colliding together with great noise, and vaporizing the water over which they passed. On October 23 the position of the erupted island was determined as lat. 36° 50' N., long. from Paris 9° 33' E. The island was then about 200 metres long by 50 metres wide. The interior of some of the masses of rock was still hot enough to melt zinc.

## CONTENTS.

	PAGE
Field Geology. By Prof. A. H. Green, F.R.S. . . . .	97
The Land of the Lamas . . . . .	98
Science and Brewing . . . . .	100
A Theory of Gravitation. By A. G. G. . . . .	100
Our Book Shelf:—	
"Indischer Ozean: ein Atlas die physikalischen Verhältnisse, und die Verkehrs-Strassen darstellend" . . . . .	101
Lock: "Mechanics for Beginners" . . . . .	101
Hull: "The Physical Geology and Geography of Ireland" . . . . .	102
Foster: "The Ouse" . . . . .	102
Letters to the Editor:—	
A Difficulty in Weismannism.—A. H. Trow; Prof. Marcus Hartog . . . . .	102
The Mexican Atlatl or Spear-Thrower.—Agnes Crane . . . . .	103
The Chromosphere Line Ångström 6676'9.—Rev. A. L. Cortie, S.J. . . . .	103
Peculiar Eyes.—Jas. Shaw . . . . .	104
Zoological Regions.—G. A. Boulenger . . . . .	104
Scientific Nomenclature.—H. St. A. Alder . . . . .	104
"The Darwinian Society."—John S. Flett . . . . .	104
Some Notes on the Frankfort International Electrical Exhibition. VI. ( <i>Illustrated</i> ). . . . .	105
Experiments in Aërodynamics. ( <i>Illustrated</i> ). By The Right Hon. Lord Rayleigh, F.R.S. . . . .	108
Preliminary Notice of a New Branchiate Oligochaete. By Frank E. Beddard . . . . .	109
The Anniversary of the Royal Society . . . . .	110
Notes . . . . .	113
Our Astronomical Column:—	
Motion of Stars in the Line of Sight . . . . .	117
The Variation of Latitude . . . . .	117
Photography of the Eclipsed Moon . . . . .	117
Proposals for a Scheme of Co-operative Observation of the So-called Luminous Clouds . . . . .	117
Scientific and Educational Intelligence . . . . .	118
Scientific Serials . . . . .	118
Societies and Academies . . . . .	119

THURSDAY, DECEMBER 10, 1891.

## GERMAN TECHNOLOGY FOR ENGLISH MANUFACTURERS.

*A Theoretical and Practical Treatise on the Manufacture of Sulphuric Acid and Alkali.* By George Lunge, Ph.D. Second Edition. Vol. I. Sulphuric Acid. (London: Gurney and Jackson, 1891.)

*The Alkali-maker's Hand-book.* By George Lunge, Ph.D., and F. Hurter, Ph.D. Second Edition. (London: Whittaker and Co., 1891.)

SULPHURIC acid plays a part, directly or indirectly, in every manufacturing industry of civilized countries. It has been said, indeed, that one could gauge the civilization of a country by the amount of oil of vitriol it consumes. It is satisfactory, therefore, to know that Great Britain produces annually nearly a million tons of this civilizing agent, or an amount but slightly less than that made by all the rest of the world.

It is, however, a remarkable and not very creditable fact that no English or Scotch man has been at any particular pains to give his fellow-men an adequate description of the details of manufacture of this civilizing agent. Of course a certain number of books of a kind have appeared; but it has been left to a German Professor to give us the first complete monograph on the subject. No one is more competent than Prof. Lunge to write authoritatively concerning the manufacture of sulphuric acid. For eleven years previous to his election to the Professorship of Technical Chemistry at the magnificently equipped Polytechnic School which the forethought and patriotism of the Swiss Government have caused to be erected at Zürich, Dr. Lunge was the manager of a large alkali-works in the north of England; and he has added to the experience thus gained by numerous visits to the other alkali manufacturing districts of Great Britain, and to those of Belgium, France, Germany, and Austria. His work, however, is not wholly based on the results of personal observation; it reflects, in fact, the existing state of chemical literature on the subject, for practically every important memoir or communication, wherever published, bearing on the manufacture, properties, or uses of sulphuric acid, is referred to and judiciously criticized. Moreover, the author's position, as director of one of the most modern and in many respects one of the best-appointed laboratories in the world, gives him unique advantages in the compilation of such a work; for, surrounded as he is by a band of earnest and enthusiastic workers, eager to aid him in elucidating the theory of established chemical manufactures or in investigating the validity of new processes, he is able to throw light on many obscure reactions by the systematic researches which he initiates, and of which the results, so far as they relate to sulphuric acid or collateral matters, are set forth in this book. It has been frequently observed that, although iron and oil of vitriol are among the most important of our staple products, we know comparatively little of the many chemical reactions which are concerned in their formation. The remark has, however, lost much of its force within recent years, and more especially in the case of sulphuric acid. During the last few years the various changes occurring within

the leaden chamber have been more carefully traced, and much definite information has been gained as to the nature of the interactions which result in the production of oil of vitriol. For not a little of this information we are indebted to Prof. Lunge and his pupils.

The present edition of this work differs in many respects from its predecessor. The ten years which have elapsed since the appearance of the first edition have seen many important changes in the manufacture of acid and alkali; and hence, with a view of bringing his treatise within reasonable compass, Prof. Lunge has been obliged to curtail much of the historical or merely retrospective portion of the work, and to omit matter which deals with views and theories which may now be considered obsolete. In spite of all this, the book has greatly increased in size, and nearly half the illustrations are new. A comparison of the two editions shows that every page has been carefully overhauled, and much fresh information is given, even on points which appeared to be settled and accepted. The present edition is remarkably free from press errors. We have only detected two: on p. 108, calcium "bisulphate," should read "bisulphite"; and on p. 899 we read that  $SO_3$  is formed when *limestone* is burnt in oxygen, especially at increased pressures; of course "*limestone*" is a *lapsus calami* for "*brimstone*."

"The Alkali-maker's Hand-book," as it is now called, has an accepted position in the laboratory literature of the chemical works of this country. The book owes its origin to a suggestion, made by Mr. Stroof, manager of the Griesheim Alkali Works, to the German Society of Alkali-makers, that a standard manual should be published, with a view of securing uniformity in analytical methods, tables of specific gravity, &c., to be employed by buyers and sellers for the valuation of chemicals, and by manufacturers for controlling and superintending their various processes, in order to avoid disagreements, and to secure exact comparison of results. A small committee of the Society was appointed, and Prof. Lunge was commissioned to collect and sift the materials for such a manual. The present work is the outcome of this action. The great danger of a book of this kind is that it is apt to get stereotyped, in the extended and figurative sense of that word; and that, owing to the natural conservatism of manufacturers, who are loth to disturb arrangements which are found to satisfy commercial necessities, there is the possibility that it may fail to reflect the state of quantitative analysis of the time. So long, however, as the work remains under the direction of Dr. Lunge and Dr. Hurter, there is very little chance of such a fate overtaking it. The present edition gives abundant evidence that care is being taken to make the book a faithful record of the condition of contemporary quantitative analysis. The work is conveniently arranged and well printed. We would take exception, however, to the character of the illustrations: these compare most unfavourably with those in Dr. Lunge's larger work. Simple outline drawings, like that of the nitrometer on p. 113, would be far preferable to the ill-drawn, ill-cut, and ill-printed designs which disfigure the book. Much of the value of the book depends, of course, on the care and accuracy with which the tables of chemical contents are compiled. We do not regard,

however, the value 122 as the atomic weight of antimony, and we strongly protest against the continued use of 197.18 as the atomic weight of platinum. We are aware of the reasons which have led to the adoption of this value, but not even a "Potash Convention" has the right to play fast and loose with a stoichiometric constant to the extent of nearly 3 units from the truth. Similar tricks were played in the old days with the atomic weights of sodium and manganese for commercial purposes. Let the Potash Convention agree among themselves to adopt any correction they please on their analytical results with a view of rendering them more accurate; but they have no right to tamper with an atomic weight in order to compensate for the imperfections of their quantitative methods. For table 22, showing the volumes of water at different temperatures, we should have preferred to use the more accurate table of Rossetti, which gives the mean results of the observations of Kopp, Pierre, Despretz, Hagen, Matthiessen, Weidner, and Kremers, and thereby tends to eliminate errors due to the employment of a special method, such, for example, as the dilatometrical method. We may also point out that the table of solubilities of certain gases in water is not based on the most modern data. Bunsen's values for oxygen have been superseded by the more accurate numbers of Winckler, Dittmar, and Roscoe and Lunt, Sondén and Petterson; and the original statement, based apparently on the work of Carius, that hydrogen is equally soluble in water at all temperatures between 0° and 20°, has been shown to be erroneous by Bohr and Bock and Timofejew.

There is a passage in the preface of Prof. Lunge's larger work which may serve to indicate the difference with which the scientific aspect of his business is regarded by the English and Continental chemical manufacturer. In presenting his book to English manufacturers, Dr. Lunge ventures to express the hope that they will not think it too "scientific." He counsels them not to despise the purely chemical detail which they will find in it. There is, it may be thought, a certain element of humour in these remarks. But Prof. Lunge is very much in earnest. He very well knows that we are still ruled by the rule of thumb in these things; the "practical man" still dominates, and nothing but the inevitable adverse dividend will move him out of the way. To what consequences the neglect of a scientific treatment of a practical subject leads, Prof. Lunge illustrates from his personal experience. He tells us that he left his native country for Great Britain rather more than five-and-twenty years ago, because industrial chemistry was but little developed in Germany:—

"The manufacture of sulphuric acid, soda-ash, and bleaching-powder was at that time quite insignificant in Germany, and not very considerable in France as compared with Great Britain; nor could the technical appliances, the yields, or even the purity of the products in the two former countries vie with those of the latter."

How different matters are now is notorious:—

"The manufacture of chemicals has made enormous strides forward, both in quantity and quality, in France, and even more so in Germany. Many of the chemicals of these countries outstrip those of English works in purity; and their plant and their processes are frequently superior to those used in the majority of English works.

Everybody knows how this has come about. The foreign chemists and manufacturers have looked all round, not merely in their own countries, but wherever they could find improved methods and apparatus; and upon the practical knowledge thus gained they have brought to bear the scientific training they had received at their Universities and Polytechnic schools. Thus they have already, in many fields formerly remunerative to British manufacturers, distanced the latter, immensely aided though these be by their long occupation of the ground, and by permanent natural advantages, such as cheapness of coal and freight, and their superior command of capital, &c.; and this is likely to go on to an increasing extent if many British chemical manufacturers decline to profit from a scientific study of their respective branches."

No one who has had the opportunity of comparing German chemical works with those of this country can be blind to the truth of these remarks. In certain branches of manufacture we are now absolutely distanced by the Germans, and in branches, too, which by priority of start and by every natural advantage ought to have been our exclusive possession. In the case of some of these we can hardly hope to recover our lost ground. Attempts have not been wanting, but it has to be admitted that British pluck and British capital have been hopelessly beaten by German energy and German capital *plus* German foresight and enlightenment. In some of these industries we may still hope to have a part, but it can only be a secondary one; and if things go on as hitherto, we must be content to be as the hewers of wood and the drawers of water. As we sow so shall we reap; and as we have sown little, it is but little that we may expect to garner.

The development of industrial chemistry in Germany during the last twenty years, and especially in those branches which depend upon the higher and more recalcitrant branches of the science, has been amazing. In the manufacture of organic products the Germans and Swiss practically command the markets of the world; nor is there the least indication that their monopoly in the case of such products as demand scientific training and skill will be or can be assailed by us at present.

Some months ago the writer was required to inspect and report upon the best examples of modern chemical laboratories to be met with on the Continent, with special reference to the work of instruction in chemical research, and in the higher branches of chemical teaching. The advice he received was most significant, and illustrates very strikingly the attitude of the German chemical manufacturer towards the science of his business. "If you want to see how organic chemistry should be worked at," said Prof. Kekulé, "go to some of our manufactories; they show us the way now. The men whom we have trained in our academic laboratories have bettered their instruction and teach their teachers." Precisely the same counsel was given by Prof. Victor Meyer: "Do you wish to see how chemical research can be organized? Then go to Ludwigshafen." And to Ludwigshafen we went. The mental impression of that spectacle of "organized research" on the banks of the Rhine will not soon be effaced. The sight, indeed, would constitute a useful object-lesson to the legislators who have sought to grapple with the subject of secondary education by handing it over to the country gentlemen. The very existence of

such gigantic concerns as Meister, Lucius, and Brüning, and the Badische Anilin und Soda Fabrik, with their thousands of workmen, their splendidly equipped laboratories, and their scores of well-trained investigators, the product of the most advanced chemical instruction that the most eminent teachers in the world can impart, is a sufficient indication of what "the scientific treatment of a practical subject" leads to.

Some days after his visit to Ludwigshafen, the writer met Prof. von Baeyer at Munich, and the talk was of Höchst and Ludwigshafen, and the influence which these and many such places must have on the industrial position of Germany. "And do you know to whom we owe all this?" asked Baeyer. There was but one answer: "To Liebig." "You are right. It is to Liebig and the Giessen laboratory." What the Augustinian cell at Wittenberg was to German theology, the little University laboratory was to German chemical science.

"The foundation of this school," says Hofmann, who was himself one of its products, "forms an epoch in the history of chemical science. It was here that experimental instruction, such as now prevails in our laboratories, received its earliest form and fashion; and if at the present moment we are proud of the magnificent temples raised to experimental science in all our [German] schools and Universities, let it never be forgotten that they all owe their origin to the prototype set up by Liebig half a century ago."

Bureaucracies, being human institutions, have occasionally been known to err, but that bureaucrat who—by recalling the two Prussian students who had dared to seek the instruction in Hesse-Darmstadt which they failed to get in their own State—raised the storm of indignation which found eloquent expression in the famous letters that roused Germany and Austria to a sense of what science could do for their material interests, has deserved a better fate than oblivion.

T. E. THORPE.

### DIPHTHERIA.

*Diphtheria: its Natural History and Prevention.* By R. Thorne Thorne, M.B., F.R.S., &c. (London: Macmillan and Co., 1891.)

THE volume before us is a republication of the Milroy Lectures, delivered by Dr. Thorne Thorne before the Royal College of Physicians in London, 1891; and all must heartily congratulate the author on the ability with which he discusses a complex and vastly important subject, and at the same time must be grateful to him for having, by republication in a handsome form, made these lectures accessible to a larger public.

Diphtheria is an infectious disease which was known before the Christian era, and was fully recognized and well described by Bretonneau in 1821. In this country it has of late years undergone, both as to its diffusion and mortality, a remarkable increase. While in former years diphtheria was considered a purely "rural" disease, of late years its repeated occurrence in large towns has raised it to an "urban" disease; so much so that, "while the metropolitan (death) rate (from diphtheria) for 1861-70 was lower than that for the country generally, it exceeded it during the two next periods, and the rise which has taken place in the rate for 1881-89 is far in

excess of the corresponding one for England and Wales." "There is thus far evidence that diphtheria as a cause of death is increasing in the country as a whole, and that this increase is very conspicuous in our greatest urban community" (p. 5). It is significant that, "concurrently (pp. 80-81) with the diminution of enteric fever, owing to advance of knowledge in the principles of health, and with the resulting intelligent administration of our sanitary laws, we find that the diphtheria death-rate is increasing in our midst." "But it is, above all, in our large towns and cities that this enlightened sanitary policy has been most marked during the past twenty years; . . . and yet, whereas when, in the past, sanitary defects abounded in our large centres of population diphtheria was essentially a disease of rural districts, that disease is now invading our more cleanly towns and cities to an extent unknown in the annals of their more faulty past."

Now, what is this increase of diphtheria in general, and the "formidable" increase in the London mortality from diphtheria in particular, due to? Although Dr. Thorne abstains from supplying a direct answer to this question, an attentive reader, after perusal of the enormous body of facts which Dr. Thorne produces, will be in a position to draw his own conclusions. This increase is certainly not to be explained by the better recognition and more correct classification of the disease (in the earlier returns of the Registrar-General certain forms of scarlatina, true diphtheria, and certain non-diphtheritic forms of croup are not well distinguished, in the later returns the distinction is carefully carried out), nor can this increase, obviously, be due to any new condition as to soil, water, and air. Dr. Thorne passes in review, and illustrates by numerous examples, collected by the most competent sanitary officers and inspectors, and minutely described in the Reports of the Medical Officer of the Local Government Board, the various conditions that have been, or were suggested as having been, connected with the origin and spread of various diphtheria outbreaks in this country; and a careful perusal of the immense body of facts recorded in this volume must impress the reader, not only with the great caution with which Dr. Thorne draws his conclusions, but with the admirably impartial way in which he tells his story, and in which he pays due regard to every detail, be it for or against. The one fact which above all others stands out prominently, and which it behoves everyone connected with our present system of compulsory school attendance carefully to consider, is the unmistakable influence of "school attendance" on diphtheria. Not the fact that diphtheria spreads from a child affected with diphtheria to another child with which it is brought in contact, either at school or at play or otherwise—a fact only too well known and unfortunately often enough actually illustrated; but the fact that "school influence"—that is, an influence affecting children aggregated in a confined space—has an important bearing on the generation of true diphtheria. This "school influence" tends to foster, diffuse, and enhance the potency of diphtheria; and this, in part at least, by the aggregation of children suffering from that sore throat which commonly is prevalent antecedent to, and concurrently with, definite diphtheria" (p. 219). Dr. Thorne devotes a considerable portion of chapter iii. to the consideration and discussion of this important subject,

and brings forward evidence, collected by himself before and after 1878, and by a number of well-known health officers and co-workers (Mr. W. H. Power, Dr. David Page, Dr. Jacob, Dr. Bruce Low, and others), which conclusively proves and confirms Dr. Thorne's proposition, first enunciated by him in 1878. Over and over again has it been shown (chapter iii.) that, in schools frequented by children some of whom were affected with simple sore throat, outbreaks of true diphtheria have occurred, for the explanation of which no antecedent case of diphtheria, nor any of the generally assumed insanitary conditions, could be brought forward. It is on these grounds that Dr. Thorne justly insists on a continued and careful inspection of the throats of the children, and on immediate separation from school of any child affected with sore throat.

The part that milk plays in the dissemination of diphtheria is fully discussed, and illustrated by a number of epidemics that have been recorded in the Reports of the Medical Officer of the Local Government Board; and the important relation of diseases of the lower animals, particularly of cows and cats, is also described and illustrated by epidemics in chapter iv. Last, but not least, Dr. Thorne considers the question of prevention and isolation. By his office as Assistant Medical Officer of the Local Government Board, and from an experience extending over many years, he stands in the unique position of the very best authority, whose conclusions and recommendations deserve carefully to be studied by managers and owners of schools, by hospital authorities, by sanitary officers and Boards of Health, by the owners of dairies, and by all those to whom the health of the community ought to be of paramount importance.

#### THE NEW YORK MATHEMATICAL SOCIETY.

*Bulletin of the New York Mathematical Society, a Historical and Critical Review of Mathematical Science.* Vol. I. No. 1, October 1891. (New York: for the Society.)

WE have occasionally wondered that now the study of mathematics is so diligently and successfully prosecuted across the Stream, there was no Society to bring together all such persons as were willing "to encourage and maintain an active interest in mathematical science." The "Organization of the New York Mathematical Society" gives a list of 174 members, mostly Professors of Mathematics or Astronomy. The President is Mr. Emory McClintock, a Vice-President of the Actuarial Society of America, who is also a member of the London Mathematical Society, and a contributor of some excellent memoirs to the *American Journal of Mathematics*. The constitution embraces six articles, and there are ten by-laws. These are apparently founded upon the rules which have been drawn up for other similar Societies. The date of the pamphlet (*i.e.* the "Organization, &c.," cited above) is June 1891. From a circular we gather that the Society has only recently inaugurated the present state of affairs, for this document states:—

"The New York Mathematical Society has consisted in the past of most of the professors and instructors of mathematics at the several Colleges situated in New York and the vicinity, the actuaries of a few of the larger

life insurance companies, and a number of other persons interested in higher mathematics. At present an extension of membership is in progress."

Then it goes on to say:—

"The Society is about to undertake the publication of a periodical review of pure and applied mathematics. The idea is not to enter into any competition with the *American Journal of Mathematics*, the *Annals of Mathematics*, or any other similar journal, but it is proposed to publish, primarily, historical and critical articles, accounts of advances in different branches of mathematical science, and reviews of important new publications; also *résumés* of lectures before the Society, short contributions from members and correspondents, and general mathematical news and intelligence. Such a periodical, if circulated extensively, will do much to incite an interest in mathematical studies, and to maintain the interest of those who, having pursued such studies, are now perhaps at a distance from others of like tastes and training. It will appeal to many that our mathematical journals do not reach."

We have allowed the Society to state its aims: these have been sanctioned by Profs. Newcomb, Woolsey Johnson, and Craig (associate editor of the *American Journal of Mathematics*). We wish the Society every success in their endeavour "to promote a long-needed spirit of active co-operation, and to establish a bond of union between American mathematicians."

The *Bulletin* contains an article on "Octonary Numeration," by Prof. Woolsey Johnson. The concluding paragraph is as follows:—

"As there is no doubt that our ancestors originated the decimal system by counting on their fingers, we must, in view of the merits of the octonary system, feel profound regret that they should have perversely counted their thumbs, although Nature had differentiated them from the fingers sufficiently, she might have thought, to save the race from this error."

The rest of the number is taken up with reviews of several books, viz. "The Teaching of Elementary Geometry in German Schools" (review of Schotten's "Inhalt und Methode des planimetrischen Unterrichts," by Prof. Ziwet); Bertrand's "Calcul des Probabilités" (by Prof. Ellery Davis); Fine's "Number-System of Algebra" (by G. Eneström, of Stockholm); and notices of works on West African longitudes and South American longitudes (by the treasurer, H. Jacoby). There are several short notes and a translation of Picard's demonstration of the general theorem upon the existence of integrals of ordinary differential equations (by the secretary, T. S. Fiske).

From this account it will be seen that there are no mathematical memoirs read before the Society in this part, but that such papers have been communicated we learn from the fact that three are printed in the current number of the *American Journal of Mathematics*, viz. one by C. Steinmetz (February 6, 1891), and two by the President (March 6, 1891).

#### OUR BOOK SHELF.

*Delagoa Bay: its Natives and Natural History.* By Rosa Monteiro. With Twenty Original Illustrations after the Author's Sketches and from the Natural Objects by A. B. and C. E. Woodward. (London: George Philip and Son, 1891.)

BOTANISTS and zoologists alike will remember the services rendered to science by the late J. J. Monteiro,

in conjunction with his wife, both in western and eastern tropical Africa, and his modest volumes on Angola and the River Congo, dedicated to his partner in the pleasures and dangers of life in a tropical climate, and his zealous aid in the collecting of objects of natural history. He was one of the three almost contemporaneous discoverers of that very remarkable plant the *Welwitschia mirabilis*—the others being Welwitsch and Baines; and he sent some of the finest specimens of it in existence to this country.

After the loss of her husband, Mrs. Monteiro returned to Delagoa Bay, and spent five years in solitude, in the cottage built for her under happier circumstances, devoting her time to collecting insects, birds, and other natural objects, and studying the life-history of insects and their relations to plants. The present book is an unpretentious narrative of her life and labours during that period, and a record of her observations and her experiments in breeding insects, illustrated with some of her own discoveries in the animal and vegetable kingdoms.

*A Hand-book of Industrial Organic Chemistry.* By Samuel P. Sadtler, Ph.D. (Philadelphia: J. B. Lippincott Company, 1891.)

In this book Prof. Sadtler has attempted to compress into about 500 octavo pages an account of those manufactures which depend upon the applications of organic chemistry. For what particular class of readers such a book is intended is rather difficult to determine. The scientific man is hardly likely to consult it in preference to the numerous special manuals to which he has access; and to the manufacturer the book is practically useless, owing to the comparative absence of all working detail. Considering the volume of literature which is required to give an approximately adequate representation of one industry alone—viz. the tar-colour manufacture—it would seem hopeless to expect anything of value from a chapter on the artificial colouring-matters, which, in well-lead “roman spaced,” attempts to give in 45 pages an account of the production and chemical nature of the numerous artificial and natural organic colouring-matters used in the arts, including their identification, chemical analysis, and detection on dyed fabrics. Certain of the other subjects are, it must be stated in fairness, treated with greater detail; and, as we should expect from Dr. Sadtler’s connections as an expert with the mineral oil industry, his description of the manufacture of petroleum and its associated products is reasonably complete. So also is the account of the cane-sugar industry. But, with the exception of the bibliographical and statistical information which occupies a relatively large share of the space devoted to each article, we see little else to commend. The book, however, is well got up; the paper and printing are all that can be desired, and the illustrations are, as a rule, much better executed than is usual in works of this class.

*Progressive Mathematical Exercises.* First Series. By A. T. Richardson. (London: Macmillan and Co., 1891.)

THE examples contained in this book are of the most elementary nature, and are intended for the use of those who have got no further than quadratic equations. In this series the exercises only deal with arithmetic and algebra, and are arranged in sets of papers which gradually become more difficult. The examples in arithmetic commence by dealing with the first four rules, simple and compound, and fractions; while those in algebra consist mostly of numerical values, addition and subtraction. Cube root and compound interest in arithmetic, and quadratic equations in algebra, form the highest limit to which these subjects are carried in this series. Throughout the work the author seems to have paid great care to insure accuracy in the answers; and

though we have worked out many problems, picked out at random, we failed to find any errors.

We may mention that, in working through the papers, the beginner will occasionally come across examples which appear to be far above the average standard; but these, on trial, will always be found very simple, and are placed there with the intention of encouraging boys to look up methods they have not reached, and so to find that “a little research enables them to do a new sort of question.”

Teachers and taught alike should find this book a useful adjunct to the text-book they have in use. W.

#### LETTERS TO THE EDITOR.

[The Editor does not hold himself responsible for opinions expressed by his correspondents. Neither can he undertake to return, or to correspond with the writers of, rejected manuscripts intended for this or any other part of NATURE. No notice is taken of anonymous communications.]

#### The Implications of Science.

IT would be a great misfortune if such views as were expressed by Dr. St. George Mivart in a lecture delivered under the ægis of the Royal Institution, and reported at length in your columns (pp. 60 and 82), were allowed to pass unchallenged. In case no able challenger appears, will you allow me to say a few words about “the implications of science”?

The great objection I take to Dr. Mivart’s view is, that he does not appear to recognize any distinction between a real and a verbal truth. He apparently puts our knowledge of “the law of contradiction” into precisely the same category as our knowledge of “our own continuous existence,” and draws but a slight distinction between these items of knowledge and such an item as the law of gravitation. Whereas, in fact, the so-called “law of contradiction” is not a necessary truth at all, it only expresses a verbal convention. It is not a law, but is of the nature of a definition. On the other hand, our knowledge of our own existence, *in the present*, comes to us by direct apprehension, and really is a “necessary truth” to each of us individually; though, since our knowledge of our existence in the past depends on the accuracy of our memories, this latter may easily be erroneous. That the memory exists is of course indisputable, but it may well be that the fact it professes to recall either took place differently, or even did not take place at all. Our confidence in our memories depends upon induction—ultimately on *inductio per enumerationem simplicem*—in just the same way as our belief in the law of gravitation does, and neither of these items of knowledge can therefore be necessary truths, though we may well hold them with so strong a conviction that the distinction may for practical purposes be ignored.

The “implications of science” which Dr. Mivart insists on are nearly all truisms (that is, purely verbal assertions)—all those to which he ascribes universal validity in any regions of time or space are such. I may repeat here what I have said elsewhere: “The supposed peculiar certainty of mathematical conclusions is solely due to the fact that they are truisms.”

For example, the assertion “Two straight lines cannot include a space” is certainly not a “necessary truth.” Either its terms are defined by connotation, so that its truth depends solely on those definitions, or else its terms are defined by denotation, as representing real things in space, and the truth of the assertion can only be proved by induction from actual experience with those things. In the first case the truth is arbitrary, not necessary; and in the second case it might conceivably be false, as was shown by Helmholtz. It is of course true that the imaginary dwellers on a sphere might still *conceive* what we call “straight lines,” but if they chose to reserve that term for geodesics of their space they would be within their rights in doing so. This is practically what Euclid does, and this is why he requires “axioms” which are *not* necessary truths; even though, in fact, they are true as far as we can test them.

So also there is no useful sense in saying that twice two must be equal to four under any conditions of time or space. Doubtless, if the inhabitants of the Dog Star defined “twice,” “two,” and “four” as we do, then “twice two” would to them be “four”; but to say that it was so could only give verbal in-

formation. And if the people in the Dog Star chose to define four as  $1 + 1 + 1$ , the so-called "necessary truth" would not even be true! Again, we do not "recognize that what we know 'is' cannot at the same time 'not be,'" we *define* it to be so. To know that anything "is," is indeed to possess real knowledge; but in order to conclude that therefore it cannot "not be," we require no further knowledge, except as to the meanings of the words employed in the argument. The "law of contradiction" never tells us whether anything "is" or "is not." It only tells us that the terms "is" and "is not" are not applicable to the same thing. This is part of the definition of the terms. If anyone chooses to say a thing both "is" and "is not," there is no law against his doing so, only if he does so he is not talking the Queen's English. Dr. Mivart is wrong in speaking of the "objective absolute validity of the law of contradiction." Its validity is not only not objective at all, but even subjectively it is not absolute, but depends on the arbitrary meanings assigned to its terms. It is exactly on a par with the assertion that at chess one king cannot give check to another.

EDWARD T. DIXON.

Trinity College, Cambridge, November 29.

### The Koh-i-Nur.

ABSENCE from home and pressing business since my return have delayed my sending a reply to Prof. Maskelyne's second article upon the above subject (*NATURE*, November 5, p. 5). So far as I can discern Prof. Maskelyne's primary object in writing these articles, it is to endeavour to maintain the hypothesis put forward by him many years ago; and with this object in view he has made a number of statements, from which I have culled not a few that may be ranged under either of two heads—firstly, those which I believe can be shown to be distinctly contrary to the evidence; and secondly, those which, if not directly contradicted by the evidence, are quite unsupported by it. In my first reply I gave samples of these statements which afforded perfectly clear issues, and as these have been unanswered, it is useless to refer to others in detail at present.

Some readers of what has already been written have expressed to me their regret that finality has not been attained by this discussion. For my own part I have a feeling of sincere regret at any additional confusion being introduced into the subject. Some of the statements referred to may, unless a warning be given, be quoted in the future, as others have been in the past, by writers who may not have the means or may not be willing to take the trouble to refer to the original authors.

There are several references in Prof. Maskelyne's last article to authors with whose writings I have considered it to be my business and duty to make myself familiar. I possess their works, and of one of them I have recently published a detailed commentary, while of another I have a commentary in course of preparation. Among these authors are Garcia de Orta and Chappuzeau, and Prof. Maskelyne's remarks lead me to conclude that he has not a very intimate acquaintance with their writings and with those of some of their contemporaries. From internal evidence it is practically certain that at the time Garcia wrote his book he had not visited the Mogul's Court, and could not, therefore, have seen his jewels, though, for the sake of argument, Prof. Maskelyne suggests he had. As for the discredited Chappuzeau, whose malicious statements are quoted without their refutation, I need only say that Prof. Jørgt's investigations have cleared Tavernier of the charges of plagiarism, &c., which were made against him, and they have further disclosed the fact that his own original manuscript documents, from which the "Travels" were prepared, are still extant (see preface to the second volume of my edition of the "Travels").

Now, as to the De Boot mistake, to which Prof. Maskelyne again refers as though it had an important bearing on the subject, it is the case that Mr. King, in a footnote, pointed out the error in De Boot's quoting as from Monardes. The footnote does not occur in Mr. King's account of the diamonds, but elsewhere. When I wrote, I had Prof. Maskelyne's quotation (*Edinburgh Review*), as from Mr. King, before me, and thus I was for the moment misled as to the extent of Mr. King's knowledge. Seeing, then, that it was Prof. Maskelyne's misquotation which misled me, his not having accepted my invitation to explain, coupled with his crowing over me for having been misled (by his own words), is one of the most extraordinary

features in this controversy. Two years ago I annotated my original paper with the remark that Mr. King had noticed the mistake of De Boot about Monardes, but it was then too late to correct the press.

The confusion which has most unfortunately been introduced into this subject by authors has now, it is to be fervently hoped, culminated in the publication by Prof. Maskelyne of a figure of a huge mounted jewel, which, going much further than his previous reference to it might have led one to expect, he labels "The Mogul." What the authority may be for this sketch, we are not clearly informed; all, apparently, that can be said for it is that "it speaks for itself." I cannot understand how Sir John Malcolm can be responsible for it, at least as it is labelled, because I know what he has published about the Shah's jewels, especially the Darya-i-Nur and its companion the Taj-e-mah. Kerr-Porter, Eastwick, and others who have described the Shah's jewels, make no mention of the existence of any such stone as this figure represents.

"It speaks for itself"; and I must venture by two alternatives to hazard an interpretation of what it says. Firstly, the amorphous-looking mass may be intended to represent some uncut stone, possibly a ruby; but why should it be the Mogul's diamond, which is known to have been cut? Secondly, it seems to be more probable that the figure may have been taken from a native sketch which originally professed to represent, but greatly exaggerated the size, and omitted the facets, of the Koh-i-Nur. Prof. Maskelyne says it was accompanied by two other stones in the same mount: so was the Koh-i-Nur (see the copies of the original model in the Tower and in several public museums). The character of the mount is somewhat similar to that in the Hon. Miss Eden's sketch of the Koh-i-Nur. This is all that, as it appears to me, can be legitimately deduced from this figure which has been left "to speak for itself."

As to Prof. Maskelyne's own sketch of the Koh-i-Nur, I thank him for it, because I think it may perhaps serve to aid readers who have not seen the original in accepting the hypothesis put forward by me, that it had been mutilated after cutting.

Through the kindness of Mr. L. Fletcher, F.R.S., Keeper of the Minerals in the British Museum, I have recently had an opportunity afforded me of seeing the original plaster model of the Koh-i-Nur, and of comparing it with a glass model similar to the one upon which my remarks as to the mutilation were based, and I find them to be identical in form and all essential details.

V. BALL.

Dublin, November 13.

### Pfaff's "Allgemeine Geologie als Exakte Wissenschaft."

In this work (Leipzig, 1873) there is a speculation (on p. 162) that in early geological times the carbonic anhydride, while yet free on the surface of the earth, was sufficient in quantity to exert a pressure of 356 atmospheres. If this had been the condition of things at any time when the surface temperature was below the critical temperature ( $30^{\circ}9\text{C}$ .), it follows that abundant liquid carbonic anhydride floated over the surface of the earth, or floated upon the seas; unless it be supposed, which is not probable, that this quantity could be held in solution in the water. Other very important and interesting effects are also involved. The statement of the 356 atmospheres has been quoted without question by so high an authority as Dr. Irving in his "Metamorphism of Rocks."

Pfaff's result, however, is based on a statement of Bischof's (as quoted by Pfaff), that the calcium carbonate of all formations would suffice to cover the surface of the earth to a depth of 1000 fuses. Pfaff takes 44 per cent. of this to be  $\text{CO}_2$ , and assumes the specific gravity of the rock to be 2.6.

On these data, and taking the *fuss* as = 0.3 metre (as stated elsewhere by Pfaff), the  $\text{CO}_2$  would exert a pressure, not of 356 atmospheres, but of 33.2, approximately. It appears, in fact, as if Pfaff's result was, through some oversight, calculated as just ten times too great.

Perhaps there is some other explanation of the discrepancy. But, lest it prove an error, I have thought well that attention should be drawn to it, the statement being made on such high authority.

J. JOLY.

Physical Laboratory, Trinity College, Dublin.



SEISMOLOGY AND ENGINEERING IN RELATION TO THE RECENT EARTHQUAKE IN JAPAN.

AT 6.38 a.m. on October 28, I was awakened at my house in Tokio by the long swinging motion of an earthquake. There was no noise of creaking timbers, and there were no shocks such as usually accompany earthquakes. It was an easy swing, which produced dizziness and nausea. As recorded by bracket seismographs this continued for ten or twelve minutes. During the interval there was ample time to study the movements of these instruments, and the conclusion that could not be avoided was that rather than acting as steady points these heavy masses were simply being swung from side to side—horizontal displacement was not being measured, but angles of tip were being recorded. That many of our seismographs are useless as recorders of horizontal motion whenever a vertical component of motion is recorded, is a view that I have held for many years, and therefore when these two have been recorded in conjunction I have been inclined to receive the records with caution.

Further, the measurement of vertical motion as recorded by a horizontal lever arrangement can only be trusted if we can assure ourselves that the advance of the waves has been at right angles to the direction of the lever. If this condition is not fulfilled, then the seismograph for vertical motion may also become a tip-recording instrument. As another indication that during this particular earthquake earth tips occurred, I may mention that the water in a tank with perpendicular sides which is about 25 feet deep, 60 feet long, and 30 feet broad, rose quickly, first on one side and then on the other, to a height of 3 or 4 feet—much in the same way that water would rise and fall in a basin that was being tipped from side to side.

Assuming what is said to be correct, it must not be concluded that modern seismographs are useless. For earthquakes where the motion is horizontal, they give records which practically are absolutely correct. When vertical motion occurs, in many cases if not in all, the records must be interpreted in a new light. The so-called horizontal displacements may be employed in determining the maximum slope of a wave, and if from an instrument recording vertical motion we are assured that we have measured the vertical height of a wave, we can at least approximate to the length of the same. The period of the waves being recorded, it follows that the velocity of propagation may be calculated.

Although it seems possible to use our present bracket seismographs as angle measurers, it is evident that there are other types of instruments, where swing due to inertia is minimized, which will act more satisfactorily. To obtain a true measure of vertical displacement, the most evident solution would be to use a number of lever arrangements in different azimuths. Other methods may, however, suggest themselves.

For the present our time is too much occupied with outside observations to attend to instruments or to reduce their records. Up to date it is known that nearly 8000 people have been killed, many having been consumed in the burning ruins where they were entombed. At least 41,000 houses are level with the plain, and engineering structures which have stood both typhoon and flood have been reduced to ruin. In the middle of the stricken district, which is near Gifu and Ozaki, it is doubtful whether any ordinary building could have resisted the violence of the movement; but outside this, much destruction might have been obviated had attention been given to the ordinary rules of construction, and to the special rules formulated by those who have considered the question of building in earthquake countries. In many places so-called "foreign" buildings of brick and

stone—undoubtedly put up in the flimsiest manner—lie as heaps of ruin between Japanese buildings yet standing. Cotton mills have fallen in, whilst their tall brick chimneys have been whipped off at about half their height. Huge cast-iron columns, which, unlike chimneys, are uniform in section, acting as piers for railway bridges, have been cut in two near their base. In some instances these have been snapped into pieces much as we might snap a carrot, and the fragments thrown down upon the shingle beaches of the rivers. The greatest efforts appear to have been exerted where masonry piers carrying 200-foot girders over lengths of 1800 feet have been cut in two, and then danced and twisted over their solid foundations considerable distances from their true positions. These piers have a sectional area of  $26 \times 10$  feet, and are from 30 to 50 feet in height. Embankments have been spread outwards or shot away, brick arches have fallen between their abutments, whilst the railway line itself has been bent into a series of snake-like folds and lummocked into waves. The greatest destruction has taken place on the Okazaki-Gifu plain, where we have all the phenomena—like the opening of crevasses, the spurting up of mud and water, the destruction of river banks, &c.—which usually accompany large earthquakes. At Okazaki and Nagoya the castles have survived. The reason for this may be partly attributable to the better class of timber employed in their construction, but principally to their pyramidal form and to the fact that they are surrounded by moats. Here and there a temple has escaped destruction, partly, perhaps, on account of the quality of materials employed in its construction, but also in consequence of the multiplicity of joints which come between the roof and the supporting columns. At these joints there has been a basket-like yielding, and the interstice of the roof has not, therefore, acted with its whole force in tending to rupture its supports. On the hills which surround the plain, although the motion has been severe, the destruction is not so great. These hills are granites, palæozoic schists, and other rocks. There is nothing volcanic. In the small cuttings where the railroad passes from the hills out into the plain, no effects of disturbance are observable, the surface motion probably having been discharged at the faces of the inclosing embankments. The general appearance outside the cuttings, however, is as if some giant hand had taken rails and sleepers and rubbed them back and forth until the ballast lying between them was formed into huge bolster-like ridges. Crossing the hills and proceeding to other plains, it is noticeable that there has been more movement on the alluvium than on the rocks.

Earthquakes yet continue, and in the Gifu plain each one is preceded by a boom as if a heavy gun had been fired in some subterranean chamber. Although the survivors, who may number, perhaps, two millions, are, for the most part, destitute, have witnessed the most terrible scenes, and are yet surrounded by the dead and the dying, yet there is no panic. They hear a "boom," and run laughing to the middle of the street to escape the shock which the unaccountable noises herald. The Japanese have their feelings, but on occasions of this sort there is no helplessness in consequence of hysteria or mental prostration. As to what happens with Europeans under like circumstances, I must leave readers to consult history.

Tokio, November 7.

JOHN MILNE.

FURTHER RESEARCHES UPON AZOIMIDE, N<sub>3</sub>H.

THE discovery of this remarkable compound of hydrogen and nitrogen by Prof. Curtius, in the chemical laboratory of the University of Kiel, formed one of the

most interesting chemical events of last year. The extraordinary nature of the compound—manifested by its fearfully explosive properties, together with its acid character, by virtue of which it forms salts with metals containing only metal and nitrogen—mark out for it a place among the most attractive of hitherto discovered substances. It was first obtained by Prof. Curtius in the form of a gas, by treating with soda a compound containing the organic radicle benzoyl in the place of the hydrogen atom, and subsequently warming the sodium salt thus produced with dilute sulphuric acid. The gas was described as possessing a frightfully penetrating odour, and as being absorbed by water with extreme avidity, forming a solution of strongly acid properties, which liberates hydrogen in contact with metals. So great, indeed, is the affinity of azoimide for water, that in these earlier experiments it was not found possible to collect the gas in the anhydrous state. Shortly after the publication of his first communication (see NATURE, vol. xlii. p. 615), an improved method of preparing the solution in water was devised by Prof. Curtius. It consisted in distilling a soda solution of a derivative containing the radicle of hippuric acid with dilute sulphuric acid. He was thus enabled to obtain a tolerably large quantity of the aqueous acid. By successive fractionation of this solution in water, and finally distilling the last product of the fractionation over fused calcium chloride, pure azoimide itself was eventually isolated, and found to be a volatile liquid, boiling at 37°.

Owing to the terribly explosive nature of both the free acid and its salts, the work has been attended with considerable danger, and has, unfortunately, been delayed by a lamentable accident which befell Prof. Curtius's assistant, Dr. Radenhausen, who was seriously injured by the explosion of a quantity of the anhydrous acid. At length, however, Prof. Curtius is able to publish some further particulars concerning the acid and its salts, and an important communication from him will be found in the current number of the *Berichte* of the German Chemical Society. The following is a brief account of these further researches, together with a *résumé* of the present state of our knowledge of this interesting compound and its derivatives.

#### Sources of Azoimide and its Derivatives.

Azoimide and its salts have been obtained from two distinct sources, both organic. One source, the first employed by Prof. Curtius, is benzoyl-glycollic acid,  $C_6H_5CO-O-CH_2COOH$ ; the second is hippuric acid,  $C_6H_5CO-NH-CH_2COOH$ . During the investigation of the reactions of his previously discovered compound of hydrogen and nitrogen, hydrazine,  $N_2H_4$ , Prof. Curtius found that both benzoyl-glycollic and hippuric acids reacted with hydrazine hydrate, forming hydrazine derivatives.

Benzoyl-glycollic acid reacts with two molecules of hydrazine hydrate, forming benzoyl hydrazine,  $C_6H_5CO-NH-NH_2$ , and the hydrazine derivative of acetic acid,  $NH_2-NH-CH_2COOH$ , with elimination of water. When benzoyl hydrazine is treated with nitrous acid, it is converted into a nitroso derivative,  $C_6H_5CO-N \begin{smallmatrix} \diagup NO \\ \diagdown NH_2 \end{smallmatrix}$ .

This nitroso compound is a very unstable substance; it spontaneously parts with water, and becomes converted into the benzoyl derivative of azoimide, benzoyl-azo-imide,

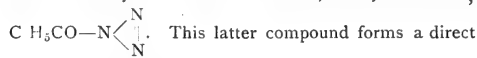

This latter compound forms a direct starting-point for the preparation of azoimide. Upon boiling with alkalis an alkaline salt of azoimide is

formed, together with benzoate of the alkali. Thus with soda

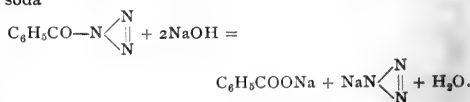

When the sodium salt of azoimide is distilled with dilute sulphuric acid, azoimide escapes as a gas, which condenses along with water in the form of an aqueous solution.

Hippuric acid reacts with one molecule of hydrazine with formation of hippuryl hydrazine,  $C_6H_5CO-NH-CH_2CONH-NH_2$ . When this substance is treated with nitrous acid, a compound is obtained which was at first considered to be a nitroso compound, but is now discovered to be in reality a diazo compound possessing the constitution  $C_6H_5CO-NH-CH_2CONH-N=N-OH$ . This substance may be isolated in quantity, and yields salts of azoimide directly upon treatment with alkalis. If soda is employed the sodium salt of azoimide is obtained, from which azoimide itself may, as before, be liberated by distilling with dilute sulphuric acid. It is more convenient, however, as will be described later, to employ it directly for the preparation of the ammonium salt of azoimide by saturating its alcoholic solution with ammonia gas; from the ammonia salt, if desired, azoimide itself may be obtained by converting it into the insoluble silver salt, and distilling the latter with sulphuric acid.

#### Preparation and Properties of the Sodium Salt of

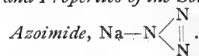

The method of preparing the sodium salt of azoimide, now adopted as most convenient by Prof. Curtius, is somewhat different from the earlier one just described, although based upon the same lines. Instead of benzoyl-glycollic acid, ethyl benzoate,  $C_6H_5COOC_2H_5$ , is employed. This substance is converted readily into benzoyl hydrazine by treatment with hydrazine hydrate:



The benzoyl hydrazine is next treated with sodium nitrite and glacial acetic acid, whereby it is quantitatively transformed into benzoyl azoimide, the benzoyl derivative of the new acid:



The benzoyl azoimide thus obtained is finally dissolved in an equal weight of absolute alcohol, and the equivalent of an atom of sodium is also dissolved in a little absolute alcohol, and the two solutions mixed; the mixture is then digested for several hours upon a water-bath, when the sodium replaces the benzoyl radicle, and ethyl benzoate is regenerated:

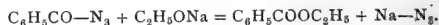

Upon cooling, the solution deposits crystals of the sodium salt, and the remainder may be precipitated from the mother-liquor by means of ether. The ethyl benzoate is recovered by distillation with very little loss, and may be employed again for the preparation of a further quantity of the sodium salt of azoimide.

The sodium salt,  $NaN_3$ , obtained by this method is substantially pure. It is very soluble in water, but is, strangely enough, not hygroscopic. It is almost insoluble in ether and alcohol. It gives a feebly alkaline reaction, and possesses a briny taste. The crystals do not explode

by percussion, but do explode when heated to a temperature which is higher than in the case of most other salts of azoimide. The explosion is accompanied by the production of a brilliant yellow flame and a detonation which is less loud than in the case of other salts. The salt is not volatile, and is not changed by evaporation of its aqueous solution.

#### Preparation and Properties of the Ammonium Salt,

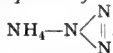

The ammonium salt, which is by far the most convenient salt to start with for the preparation of the free acid and its metallic salts, is best prepared from the curious diazo compound of the amide of hippuric acid,  $\text{C}_6\text{H}_5\text{CO}-\text{NHCH}_2\text{CO}-\text{NH}-\text{N}=\text{N}-\text{OH}$ , before mentioned. This substance is readily obtained in calculated quantity by first acting with hydrazine hydrate upon the ethyl ether of hippuric acid, and subsequently treating the hippuryl hydrazine thus produced with sodium nitrite and glacial acetic acid. Diazo-hippuramide appears to be most prolific in its reactions. Prof. Curtius states that it reacts with almost every class of organic and inorganic bodies with which he has brought it in contact, and generally without the application of external heat. Thus, when treated with water, alcohol, haloid ethers (alkyls), aldehydes, free halogens, or hydrazine derivatives of organic acids, it evolves free nitrogen gas, and forms compounds which are derived from hippuramide by replacement of a hydrogen atom in the  $\text{NH}_2$  group by the radicle of the reacting substance. On the other hand, when acted upon by alkalies, ammonia or substituted ammonias (amines), or by diamide (hydrazine) and its derivatives, salts of azoimide are formed. Thus last reaction, when ammonia is employed, forms the most convenient mode of obtaining the ammonium salt of azoimide.

About a pound of diazo-hippuramide is placed in a flask of 2 litres capacity, and covered with 600 grams of 85 per cent. alcohol. The flask is then placed in a freezing mixture, and ammonia gas is led in until the liquid is saturated with it. The flask and contents are then allowed to stand twenty-four hours in order to complete the reaction, when the diazo compound is quantitatively converted into hippuramide and the ammonium salt of azoimide:



The liquid is then boiled, the flask being fitted with an upright condenser, until no more ammonia escapes, when the heat is removed, and the solution allowed to cool. After standing another twelve hours, the clear alcoholic solution is decanted from the mass of hippuramide crystals, and treated with four times its volume of ether, when 70 per cent. of the total yield of the ammonium salt is precipitated in the form of a white powder. The remaining 30 per cent. of the azoimide may be recovered by recrystallizing the hippuramide from water, adding the mother-liquor to the ethereal-alcoholic solution after removal of the precipitated ammonium salt, and treating the whole of the liquid with solutions of lead, silver, or mercurous salts, when the azoimide is precipitated in the form of the difficultly soluble lead, silver, or mercurous salts. The hippuramide is readily converted, by boiling with hydrazine hydrate, into hippuryl hydrazine, which may thus be used again for the preparation of more of the diazo compound.

The precipitated ammonium salt is washed with ether and dried in the air. The snow-white crystalline powder thus obtained, consisting of fine anisotropic needles, may be recrystallized from boiling alcohol. It is only

sparingly soluble in absolute alcohol, but on boiling for some time in a flask fitted with inverted condenser, the whole passes into solution. Upon cooling, the salt separates out in large colourless crystals, tabular in form, and frequently aggregated in step or fan-shaped forms. These aggregates often resemble those of ammonium chloride very closely, but the crystals do not belong to the cubic system. The crystals are readily soluble in water, and, upon allowing the aqueous solution to evaporate *in vacuo*, large transparent prisms are obtained, which, however, soon become turbid in air.

The ammonium salt of azoimide reacts in a feebly alkaline manner. It is not hygroscopic, although so readily soluble in water. It dissolves easily in 80 per cent. alcohol, but, as above described, with difficulty in absolute alcohol. It is insoluble in ether and benzene. It is distinguished by its great volatility. When the crystals are allowed to lie exposed to air, they gradually disappear, eventually passing away entirely in the form of vapour. Upon gently warming a small quantity of the salt in a test-tube to a temperature very slightly superior to  $100^\circ$ , it sublimates like ammonium chloride, condensing again, however, in brilliant little prisms. This operation requires great care, for if the heating proceeds too rapidly the substance explodes with great violence.

As may be expected, great difficulties were met with in obtaining an analysis of a substance so explosive. Upon attempting to determine its composition by combustion with copper oxide in a stream of dry air, the apparatus was destroyed upon each occasion with a fearful detonation. Only one-tenth of a gram of the salt was employed, placed in a small platinum boat. At first the compound sublimed out of the boat into the cooler portion of the combustion tube; the little sublimed crystals then commenced to fuse into yellow drops, and immediately this occurred, in each experiment, the tube was shattered to fragments with a frightful report. The platinum boat was in each case torn to fine splinters. Eventually, however, Prof. Curtius succeeded in obtaining a satisfactory analysis by performing the combustion with copper oxide in a stream of carbon dioxide.

The ammonium salt may be readily converted into the sodium salt by evaporation with caustic soda upon a water-bath.

#### Preparation and Properties of Free Azoimide, $\text{H}-\text{N} \begin{array}{l} \diagup \text{N} \\ \parallel \\ \diagdown \text{N} \end{array}$

An aqueous solution of azoimide may be prepared by distilling any of its salts, preferably the sodium or silver salts, with dilute sulphuric acid. It is more conveniently obtained, however, by dissolving the crystals of diazo-hippuramide in dilute caustic soda, warming the solution for a short time upon a water-bath, so as to insure the formation of the sodium salt, and subsequently distilling the liquid with dilute sulphuric acid. The latter is allowed to drop slowly from a dropping funnel upon the soda solution contained in a flask and maintained at the temperature of ebullition. The flask is connected with a condenser, and the azoimide, as it escapes, is carried along with the steam, and condenses in the receiver in the form of an aqueous solution. This solution may be concentrated by precipitating it with silver nitrate, collecting the insoluble silver salt, and distilling it with sulphuric acid diluted with eight times its volume of water. The aqueous solution of azoimide possesses a most intolerable odour.

Free azoimide itself may be obtained by the fractional distillation of the concentrated aqueous solution thus prepared. The first fraction is collected separately and refracted. Upon repeating this process with four successive first fractions, an acid containing over 90 per cent. of azoimide is obtained, which distils at about  $45^\circ$ . The last 10 per cent. of water may be completely removed

by means of fused calcium chloride, after treatment with which pure anhydrous azoimide distils over.

Azoimide is a clear, colourless, mobile liquid, which boils without decomposition at  $37^{\circ}$ . It is endowed with the same intolerable odour as the solution. Its most characteristic property, however, is its frightful explosiveness. It explodes in a most erratic manner—sometimes, without the least apparent provocation, at the ordinary temperature. Its distillation is an operation attended with great danger; Prof. Curtius and his assistant *have* succeeded, as above described, in isolating it and determining its boiling-point several times; but upon other occasions, under apparently the same conditions, the experiment has ended with a disastrous explosion. When suddenly heated, or touched with a hot body, it always explodes. The explosion is accompanied by an intensely vivid blue flame. The damage wrought by the explosion of very minute quantities is most surprising. The thousandth part of a gram, placed upon an iron plate, and touched by a hot glass rod, is sufficient to produce a loud detonation, and considerably distort the iron plate. The twentieth part of a gram was found sufficient to completely pulverize a Hofmann "density" apparatus, when an attempt was made to determine its vapour-density in the Torricellian vacuum at the ordinary temperature. Upon another occasion, seven-tenths of a gram, contained in a closed glass tube, upon removal from the freezing mixture in which it had been immersed exploded with such immense force as to shatter every piece of glass apparatus in the laboratory. It was upon this occasion that Prof. Curtius's assistant was so seriously injured as to cause the temporary abandonment of the work. The aqueous solution is almost as explosive as the anhydrous liquid, the explosion of two cubic centimetres of a 27 per cent. solution upon one occasion shattering the glass tube into dust so fine that Prof. Curtius, who was attempting to seal it, escaped uninjured.

The anhydrous liquid readily dissolves in water and alcohol. The aqueous solution is strongly acid to litmus. Magnesium, aluminium, zinc, iron, and even copper are rapidly attacked by it, hydrogen being evolved. Gold and silver are likewise attacked, although not so rapidly. In the case of gold a red solution of the gold salt is formed; the silver salt being insoluble soon prevents further action in the case of silver.

The anhydrous compound appears to be decomposed by concentrated sulphuric acid.

#### \* Other Metallic Salts of Azoimide.

The silver salt,  $\text{Ag}-\text{N} \begin{array}{c} \diagup \text{N} \\ | \\ \diagdown \text{N} \end{array}$ , is obtained in the form of

a white precipitate whenever a soluble silver salt is added to azoimide, its aqueous solution, or solutions of its salts. It resembles silver chloride very closely in appearance, but is not darkened by the action of light. There is very little difficulty in distinguishing between the two salts, however, inasmuch as the silver salt of azoimide partakes of the frightfully explosive properties of the free acid. It is the most dangerous of all the salts to handle. In spite, however, of this explosiveness, Prof. Curtius has *once*, and only once, succeeded in obtaining a determination of its nitrogen content, by combustion in a long layer of copper oxide. The number obtained was 27.65. The value calculated from the formula  $\text{AgN}_3$  is 28.00. In every other experiment the tube was shattered into fragments, notwithstanding the finest subdivision and distribution among the copper oxide.

The precipitated silver salt is soluble, like silver chloride, in ammonia. Upon evaporation of the solution, however, instead of obtaining an ammoniacal double compound, the silver salt itself crystallizes out in almost colourless crystals half an inch long. These crystals, as may be

imagined, are most delicate objects to handle; they explode even upon breaking the prisms across. They are almost perfectly insoluble in water.

The mercurous salt,  $\text{HgN}_2$ , is likewise insoluble in water, and may be readily obtained by precipitation of the free acid or its soluble salts with mercurous nitrate. It has the advantage of being more safely handled than the silver salt, and is less sensitive to percussion. It also requires a higher temperature to bring about explosion by heating. It is usually obtained by precipitation in the form of microcrystalline anisotropic needles. It becomes coloured yellow when exposed to light. Like mercurous chloride, it forms a black compound with ammonia.

The lead salt,  $\text{PbN}_2$ , resembles lead chloride very closely. It is insoluble in cold water, but dissolves somewhat in boiling water, though not to such an extent as lead chloride, about half a gram dissolving in a litre of boiling water. Upon cooling, brilliant colourless needles, attaining sometimes the length of half an inch, separate out. It may be best obtained by precipitating the solution of the sodium or ammonium salt with lead acetate. The precipitate is soluble in excess of lead acetate. The crystals of the lead salt explode with fearful force when slightly warmed. By long boiling with water this lead salt appears to be decomposed, a non-explosive lead compound separating, and free azoimide escaping. Warm acetic acid also dissolves it, with gradual decomposition and liberation of azoimide.

The barium salt,  $\text{BaN}_2$ , is readily obtained by neutralizing the acid with baryta, and crystallizes from solution in large lustrous crystals. It is likewise a highly explosive salt, and the explosion is accompanied by the production of a brilliant green flame.

#### Ethereal Salts of Azoimide.

The metallic salts of azoimide may be readily converted into ethereal salts by reacting upon them with haloid ethers. The phenyl ester has been prepared by Prof. Curtius, and is found to be identical in every respect with

the long known diazobenzene imide,  $\text{C}_6\text{H}_5\text{N} \begin{array}{c} \diagup \text{N} \\ | \\ \diagdown \text{N} \end{array}$ . The

aromatic esters are generally remarkably stable substances, and it was consequently found impossible to obtain azoimide by the direct saponification of diazobenzene imide with soda. Within the last few months, however, Drs. Noelting and Grandmougin, of Mülhausen, have succeeded in preparing azoimide indirectly from diazobenzene imide, by first diminishing somewhat the stability of the compound by introducing two nitro groups into it. Upon treating dinitro-diazobenzene imide with alcoholic potash, the potassium salt of azoimide was at once formed. Upon distilling this with dilute sulphuric acid, an aqueous solution of azoimide was obtained, and eventually anhydrous azoimide itself, identical in all respects with that obtained by Prof. Curtius.

#### Hydrazine Salt of Azoimide, $\text{N}_2\text{H}_4 \cdot \text{N}_2\text{H}_4$ .

This interesting substance, formed by the union of equal molecules of the two remarkable compounds, hydrazine and azoimide, whose isolation we owe to Prof. Curtius, is a solid substance forming large well-defined crystals. It is obtained when one molecular equivalent of hydrazine hydrate (the preparation and properties of which were described in NATURE, vol. xliii. p. 205) is added to the ammonium salt of azoimide, and the mixture, placed in a shallow dish, is allowed to evaporate in a desiccator. It is curious, also, that by adding a very concentrated aqueous solution of azoimide, obtained by distilling 60 grams of the lead salt with dilute sulphuric acid, to hydrazine hydrate, until litmus is turned strongly blue by the mix-

ture, one does not obtain, as might be expected, the salt  $2\text{N}_2\text{H}_4 \cdot \text{N}_2\text{H}_4$ ; on the contrary, the mono-salt,  $\text{N}_2\text{H}_4 \cdot \text{N}_2\text{H}_4$ , is again formed; and if the mixture is placed in a desiccator containing solid caustic potash and oil of vitriol, crystals of the mono-salt are deposited, and the excess of azoimide escapes and is absorbed by the potash.

The mono-hydrazine salt crystallizes in lustrous, anisotropic prisms an inch long, which melt at  $50^\circ$ . They rapidly deliquesce in air. They are soluble with difficulty in boiling alcohol, and crystallize from the solution, on cooling, in brilliant leafy crystals. The crystals burn quietly with a smoky flame when brought in contact with a flame, leaving no trace of residue. Owing to the strong reducing power of the liberated glowing hydrogen, metallic surfaces upon which the crystals may be ignited become brightly cleaned, as if polished, being freed from the least trace of oxide. When the crystals, however, are rapidly heated, or touched with a white-hot wire, they explode with fearful violence. The explosion may also be brought about by detonating in the neighbourhood a little of one of the metallic salts of azoimide. Even in the deliquesced state the substance retains its fearfully explosive properties.

In conclusion, it may be remarked that Prof. Curtius has further succeeded in preparing a number of derivatives of the as yet unisolated compound of hydrogen and nitrogen, triamide,  $\text{NH}_2\text{—NH—NH}_2$ , by the action of the hydrazine compounds of several organic acids upon diazohippuramide. The organic radicles are so rigidly attached in these derivatives that he has not yet been fortunate in displacing them. It appears very probable, however, that before long some means of effecting this object will be discovered, and that Prof. Curtius will further add to his achievements by making us as familiar with triamide as we now are with hydrazine and azoimide.

A. E. TUTTON.

### BEAST AND MAN IN INDIA\*

THE natives of India have been described from many different points of view, but Mr. Kipling is the only writer to whom it has occurred to give a full account of their relations to animals. The task is one for which he is admirably fitted, and he has fulfilled it in a way that cannot fail to secure for the book an enduring place in the literature relating to Indian subjects. The work has considerable scientific value, not only because the author presents the people of India in a new light, but because he has much that is fresh to say about the animals to which he refers. Animals have a great attraction for him, and his notes on their habits have the brightness and charm that belong only to records of direct personal observation. The volume is enriched with many clever illustrations, the majority of which are from drawings by Mr. Kipling himself. Most of the others are from drawings by native artists. Several of these illustrations we are enabled to reproduce.<sup>2</sup>

There is a general impression in Europe that animals are treated kindly in India. This impression is only in part confirmed by Mr. Kipling. It is true that the Hindus, believing in the transmigration of souls, are reluctant to take animal life; but that, says Mr. Kipling, "does not preserve the ox, the horse, and the ass from being unmercifully beaten, over-driven, over-laden, underfed, and worked with sores under their harness; nor does it save them from abandonment to starvation when unfit for work, and to a lingering death which is made a long torture by birds of prey, whose beaks, powerless to kill

outright, inflict undeserved torment." Even the sacred cow is not so well treated as the milch cows of Europe. Mr. Kipling's statements on this subject are extremely unpleasant reading, but it is to be feared that they are only too well founded. With regard to free creatures, however, he is able to give a better report. The village school-boy does not stone frogs, or set dogs at cats, or tie ketles to dogs' tails, or go bird-nesting, or annoy squirrels; and "the sparrow, the crow, the maina, and the hoopoe move from his path without a flutter of fear." The farmer, too, endures with extraordinary patience deprivations on his crops by wild animals. The monkey, the nilghai, the black buck, the wild pig, and the parakeet fatten at his expense, and do not even reward him by killing a caterpillar or a weevil. There are bird-catchers in India, but the popular feeling about them is shown in a scornful proverb on their ragged and disreputable condition.

One of the brightest chapters in the book is on monkeys, which the author has had good opportunities of observing. The monkey most commonly seen both in the hills and plains is the Macaque (*Macacus rhesus*), which is not to be confounded with the tall, long-tailed, white-whiskered Langür (*Presbytes illiger*). The latter is clad in an overcoat of silver-grey. He is, in his way, a king of the jungle, and is not so often met with in confinement as his brown brother. The Hooluck, or Black Gibbon (*Hylobates hooluck*), is most often found in Bengal and Assam, and, if a pair can be secured, easily reconciles itself to captivity; but it is "a depressing companion." An Assam monkey, known as "the shame-faced one," is "a gentle, bashful, large-eyed creature, with a quaint trick of hiding its face in its hands and hanging its head like a timid child."

The monkey is held in great respect in India, and Hanumān, the monkey-god, is one of the most widely-worshipped of Hindu deities. Sacred as the animal is, the people are thoroughly alive to the faults of its character, and in ordinary talk the monkey is used, as in Europe, "to point morals against wanton mischief, helplessness, and evil behaviour generally." For some months a number of wild monkeys were daily fed by Mr. Kipling and his family; and they soon learned to distinguish by smell between fresh and stale biscuits. Yet—as the natives have noted in proverbs—monkeys are not sharp enough to provide themselves with shelter against the heavy rains of the country. In the Simla region they may be seen in troops sitting shivering for hours within a few yards of covered spaces. The scheme of their life, according to Mr. Kipling, seems to be patriarchal, with a touch of military organization, the patriarch being "at once commander-in-chief and effective fighting force." The natives call him "Maharajah," and the name is well chosen, as he is "the very type and incarnation of savage and sensual despotism." Monkey mothers treat their little ones with a tenderness "that endears them to the child-loving Oriental"; and the young, when the sun shines, often contrive to have a good time. Says Mr. Kipling:—

"They have a game like the English boys' cock of the dung-hill or king of the castle, but instead of pushing each other from the top of a knoll or dust-heap, the castle is a pendent branch of a tree. The game is to keep a place on the bough, which swings with their weight as with a cluster of fruit, while the players struggle to dislodge one another, each, as he drops, running round and climbing up again to begin anew. This sport is kept up for an hour at a time with keen enjoyment, and when one is nimble as a monkey it must be splendid fun."

Mr. Kipling finds in cows and oxen the subject of another capital chapter. They seem to him to be the foremost figures in both the rustic and the urban scenery of the country. The cow is now "firmly enthroned in the Hindu pantheon," and the peculiar sanctity in which

\* "Beast and Man in India." By John Lockwood Kipling, C.I.E. With Illustrations. (London: Macmillan and Co., 1891.)

<sup>2</sup> Figs. 1, 2, and 4, are by Mr. Kipling. Fig. 3 is by Māshī Sher Muhammad.

she is held may, he thinks, be partly due to the fact that in early Aryan mythology she was used as a symbol of the clouds attendant on the Sun-god. Mr. Kipling expresses much admiration for Indian oxen, of which he says that it is with them as with the people of India—



FIG. 1.—Young monkeys at play.

Mr. Kipling notes the peculiar impression produced on Europeans by the silence of Indian cattle. Students, reading in Gray's Ode of the lowing herd, will say to the Professor, "Sir, what is lowing?" Even the grunting note of the ox and cow is seldom heard, and does not carry. The herdsman is a vocalist, but his song "is always in a minor key, and has falsetto subtleties in it that baffle our methods of notation." He talks a good deal in a loud heavy voice; and "when his women folk walk with him they follow respectfully an ordained number of paces behind, and he flings his conversation over his shoulder."

It would be impossible, of course, to write a book about "Beast and Man in India" without treating of



FIG. 3.—A painted elephant.

"the more you learn about them the more you find to interest you." Fig. 2 represents roughly the range of their size. Even larger beasts than the largest shown sometimes occur. The smallest belongs to a miniature



FIG. 2.—Comparative sizes of the largest and smallest breeds of Indian oxen.

race which is not much bigger than a Newfoundland dog. This little creature is exquisitely finished in every detail of ox form; it is full of life and spirit, and, when harnessed to vehicles of a suitable size, it trots at a great pace.

elephants; and Mr. Kipling discourses on them most pleasantly. The elephant seems to be second only to the cow in Hindu estimation. In Hindu art other animals are treated only in a decorative and conventional style; but in artistic representations of the elephant, whether in sculpture or in painting, there is invariably "a strong feeling for nature." This contrast is seen in most old temples, but especially in the sculptured gates of the Sanchi tope in Central India, "where all kinds of animals are shown, but the elephant alone is carved with complete knowledge and unvarying truth of action."

Mr. Kipling is at great pains to convey a true idea of the character of the elephant, the essential quality of which he takes to be gentleness. He also tells many curious legends about the animal, and about Ganésha, the elephant-headed god, who is not less popular than the monkey-god. The dressing of the elephant for parade is also described. This, although an elaborate process,

is not really much more difficult than the dressing of a child for church. The most remarkable part of the process is the painting of the forehead, trunk, and ears, which follows a thorough washing. "The designs are often good, and the whole serai, excepting always the elephant himself, is deeply interested. His mind and trunk wander; he trifles with the colour-pots; so with each stroke comes an order to stand still. Some mahouts are quite skilled in this pattern work."

In an interesting chapter on the training of animals, Mr. Kipling shows that the skill of the natives of India in this difficult art has often been greatly overrated. The Oriental brings "boundless patience" to the task, but "he has no steadfastness of aim, nor has he sufficient firmness of hand and will to secure confidence and obedience." The cheetah or hunting leopard (*Felis jubata*), when caught and tamed, undergoes so little training in the field that it loses its natural dash, and is often left behind by the antelope. It becomes so mild

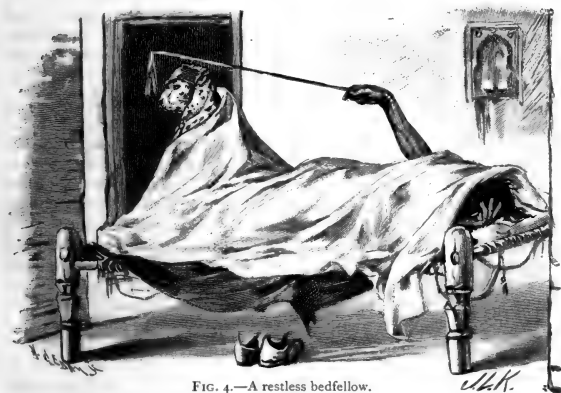

FIG. 4.—A restless bedfellow.

that it is frequently allowed to curl itself under the same blanket with its keeper. The keeper, when his bedfellow is restless, "lazily stretches out an arm from his end of the cot, and dangles a tassel over the animal's head, which seems to soothe him." In the early morning Mr. Kipling has seen a cheetah "sitting up on his couch, a red blanket half covering him, his tasselled red hood pushed awry, looking exactly like an elderly gentleman in a nightcap, as he yawned with the irresolute air of one who is in doubt whether he will rise or turn in for yet another nap." This is mentioned as an instance of the curious intimacy that exists in India between animals and those who have charge of them.

Of the remaining chapters we can only say that all of them embody the results of a close study of the animal world and of the Hindu character. We may note as of especial interest the three concluding chapters, on animals in Indian art, on beast fights, and on animals and the supernatural.

#### ON AN OPTICAL PROOF OF THE EXISTENCE OF SUSPENDED MATTER IN FLAMES.<sup>1</sup>

DEAR PROFESSOR TAIT,—I write to put on paper an account of the observation I mentioned to you to-night, in case you should think it worth communicating to the Royal Society of Edinburgh.

In the course of last summer I was led, in connection with some questions about lighthouses, to pass a beam

<sup>1</sup> Read before the Royal Society of Edinburgh on June 15, 1891. Reprinted from the Proceedings of the Society.

of sunlight, condensed by a lens, through the flame of a candle. I noticed that where the cone of rays cut the luminous envelope there were two patches of light brighter than the general flame, which were evidently due to sunlight scattered by matter in the envelope which was in a state of suspension. The patches corresponded in area to the intersection of the double cone by the envelope, and their thickness was, I may say, insensibly small. Within the envelope, as well as outside, there was none of this scattering. The patches were made more conspicuous by viewing the whole through a cell with an ammoniacal solution of a salt of copper, or through a blue glass coloured by cobalt. In the former case the light from the flame was more weakened than the scattered light, which was richer in rays of high refrangibility; in the latter case the patches were distinguished by a difference of colour, the patches being blue, while the flame (with a suitable thickness of blue glass) was purplish. The light of the patches exhibited the polarization of light scattered by fine particles—that is to say, when viewed in a direction perpendicular to the incident light it was polarized in a plane passing through the beam and the line of sight.

When the beam was passed through the blue base of the flame there was no scattered light. A luminous gas flame showed the patches indicating scattered light like the flame of a candle, but less copiously. They were not seen in a Bunsen flame or in the flame of alcohol, but were well seen in the luminous flame of ether. When a glass jar was inverted over burning ether, the blue part, which does not show scattered light, extended higher, till, just before the flame went out, the luminous part disappeared altogether. A Bunsen flame, fed with chloride of sodium, did not show the phenomenon, though the flame was fairly luminous.

The phenomenon shows very prettily the separation of carbon (associated, it may be, with some hydrogen) in the flame, and at the same time the extreme thinness of the layer which this forms. It shows, too, the mode of separation of the carbon—namely, that it is due to the action of heat on the volatile hydrocarbon or vapour of ether, as the case may be. At the base, where there is a plentiful supply of oxygen, the molecules are burned at once. Higher up the heated products of combustion have time to decompose the combustible vapour before it gets oxygen enough to burn it. In the ether just going out, for want of fresh air, the previous decomposition does not take place, probably because the heat arising from the combustion is divided between a large quantity of inert gas (nitrogen and products of combustion) and the combustible vapour, so that the portion which goes to the latter is not sufficient to decompose it prior to combustion.

In the Bunsen flame fed with chloride of sodium, the absence of scattered light tallies with the testimony of the prism, that the sodium is in the state of vapour, though I would not insist on this proof, as it is possible that the test of scattering sunlight is not sufficiently delicate to show the presence of so small a quantity of matter in a solid or liquid state.—Yours sincerely,

G. G. STOKES.

P.S.—I fancy the thinness of the stratum of glowing carbon is due to its being attacked on both sides—on the outside by oxygen, on the inside by carbonic acid, which with the glowing carbon would form carbonic oxide.

[When the above was written, I was not acquainted with the previous paper by Mr. Burch, published in vol. xxxi. of NATURE (p. 272), nor did any of the scientific friends to whom I had mentioned the observation seem to be aware

of it. Had I known of it, I should not have thought my paper worthy of being presented to the Royal Society of Edinburgh, as Mr. Burch has anticipated me in the fundamental method of observation.

The reaction mentioned in the postscript is to be taken merely as a specimen of the reactions, on the inside of the carbon stratum, by which the carbon may be re-engaged in a gaseous combination. Carbonic oxide is only one of the combustible gases, not originally present, which are formed during the process of combustion, and are found inside the envelope in which the combustion is going on.—G. G. S., *November 20, 1891.*]

### NOTES.

THE annual general meeting of the Institution of Electrical Engineers will be held at the Institution of Civil Engineers, 25 Great George Street, Westminster, this evening (Thursday), at 8 o'clock, for the reception of the annual report of the Council, and for the election of Council and officers for the year 1892. The following paper will be read:—"On the Specification of Insulated Conductors for Electric Lighting and other purposes," by W. H. Preece, F.R.S., Past-President.

THE Royal Danish Academy of Sciences at Copenhagen offers two prizes of 400 and 600 kronen respectively, for investigations on the exact nature and proportions of the more important carbo-hydrates present, at different stages of maturity, in the cereals in most general use; and for investigations on the *Phytoptus* galls found in Denmark, with a monograph on the insects producing them. The prizes are to be awarded in October 1893.

AN improved armillary sphere has been patented by Prof. J. S. Slater, of Calcutta University, which differs from other spheres of the same kind in having a latitude circle to which the celestial sphere is hinged, and in being provided with a movable horizon which adjusts itself to the selected latitude. It can be obtained from Messrs. Walsh, Lovett, and Co., Philpot Lane, E.C.

THE next one-man photographic exhibition organized by the Camera Club will consist of pictures by Mr. J. Pattison Gibson, of Hexham. It will be opened in connection with a concert to be held on the first Monday in January, 1892.

WITH the consent of the Sultan of Muscat, the Survey of India is about to establish a tidal observatory at Muscat. This will probably be followed by the establishment of another observatory of the same kind at Bushire in the Persian Gulf.

We have had some correspondence with Prof. Arnold about our notice of his speech at the recent meeting of the Institution of Mechanical Engineers. Referring to his remarks on Prof. Roberts-Austen's "Report to the Alloys Research Committee," we expressed the opinion that it was rather straining the prerogative of rhetoric to speak of the work done by Prof. Roberts-Austen as "not worth a rush." We did not intend to imply that Prof. Arnold applied the expression "not worth a rush" to the whole of the work on which Prof. Roberts-Austen reported. He wishes us to state that what he said was, that he thought "any analogue obtained from a comparison of simple bodies like gold and lead with a complex body like steel would not be worth a rush."

THE reports of the examiners on the results of the science examinations held in April and May 1891 have been issued. The examinations related to building construction, naval architecture, mathematics, theoretical mechanics, applied mechanics, magnetism and electricity and alternative elementary physics,

chemistry, geology, mineralogy, animal physiology, botany, the principles of mining, navigation and nautical astronomy, steam, the principles of agriculture, and hygiene.

MRS. R. M. CRAWSHAY, writing to us from Mentone, on December 2, about the recent eclipse of the moon, refers to the fact that "the Rev. A. Freeman and Mr. R. T. Leslie are not agreed as to the shadow on the moon's disk having colours or not." For some time there were illuminations and fireworks at Monte Carlo on account of the birthday of the Prince of Monaco, and, when these were over, clouds suddenly came up. "It was only," Mrs. Crawshaw says, "when the moon was very nearly half obscured that I caught a glimpse of her without any colouring whatever, orange or otherwise. One could only liken it to a painting in Indian ink."

MR. GEORGE T. BETTANY, who was well-known as a popular writer on scientific subjects, died on December 2 in his forty-second year. For some years he lectured on botany at Guy's Hospital. Conjointly with Prof. Parker, he wrote a work on "The Morphology of the Skull." He was also the author of "The World's Inhabitants," and other books. For Messrs. Ward, Lock, and Co., he edited "Science Primers for the People" and "The Minerva Library."

AN interesting paper on aluminium and its application to photography, by Mr. G. L. Addenbrooke, is printed in the December number of the *Journal of the Camera Club*. Mr. Addenbrooke thinks aluminium ought now to supersede brass for photographic lenses and the metal parts of cameras. By its use the weight of lenses, flanges, and adapture is reduced nearly to one-third. He is also in favour of aluminium being used for the revolving tripod heads fixed in the bare boards of cameras, as these are rather too heavy in brass. "In hand-cameras," he says, "I think the metal should be useful in most places where there are metal parts. I am also not without hopes that dark slides may be made in it altogether, which will be lighter and more compact than the wooden ones. For developing-dishes, also, it is very suitable, as the action of most of the chemicals used in photography is very slight on it, and when there is any, the compounds formed would not be harmful."

IN his latest communication to the *American Journal of Science* (for November), Prof. Goodale describes his visit to the Queensland Museum at Brisbane, under the charge of Mr. De Vis, rich in specimens illustrating the natural history and ethnology of the colony. An account is also given of the well-known Botanic Garden and Laboratories at Buitenzorg in Java, under the directorship of Dr. Treub, and of the annex on a contiguous mountain; of the Botanic Garden and Experimental Garden at Singapore, under the control of Mr. Ridley; and of the new and at present but poorly developed Botanic Garden at Saigon in French China.

POISONING by mussels is a well-known fact. Such poisoning appears in chronic form in Tierra del Fuego, mussels being abundant on the shores, and other kinds of food rare, so that the natives eat large quantities of the former daily, both of bad and of good quality. According to a doctor of the Argentine fleet, M. Segers, the mussels are rarely injurious at their maximum time of growth, which corresponds with full moon, but when the moon wanes, they become poor and often poisonous. The poisonous quality apparently results from the death of a large number at this time, and the putrefaction of their bodies yielding ptomaines which are absorbed by the surviving mollusks. In any case, the Fuegians are often attacked by a liver complaint, consisting in atrophy of the organ, with jaundiced colour of the skin and tendency to hæmorrhage; and M. Segers believes this is due to mussel poisoning. He finds sulphate of atropine an efficacious antidote.



PRINCIPAL J. L. THOMPSON, of the Hawkesbury Agricultural College, New South Wales, has no doubt that the climate and much of the soil of Australia are well suited for the culture of the olive. All that is needed, he thinks, is an adequate supply of labour. He himself has been very successful in preserving green olives; and in a paper on the subject in the August number of the *Agricultural Gazette* of New South Wales he gives the following account of the system adopted. The olives are very carefully picked from the trees when about full grown, but perfectly green. They should be handled like eggs. If they are bruised in any way, they will become black and decompose. In the green state, olives contain gallic acid, which gives them an acrid taste. To remove this they are first of all steeped in alkaline water, made either of wood ashes, lime water, or washing soda; of the latter, about three or four ounces to the gallon of water. As soon as the lye has penetrated through the pulp, which is usually in from eight to ten hours, they are put into clean water and steeped until all acrid and alkaline taste has been removed. During that time the water is changed every day. They are then put into brine, composed of one pound of salt to each gallon of water, and kept carefully covered with a thick linen cloth, for if exposed to the air they will turn black. They are finally put up in air-tight jars.

THE Meteorological Department of the Government of India has published Part IV. of "Cyclone Memoirs," being an inquiry into the nature and course of storms in the Arabian Sea, and a catalogue and brief history of all recorded cyclones in that sea from 1648 to 1889. The work, which has been prepared by Mr. W. L. Dallas, chiefly for the use of mariners navigating those parts, will no doubt be of considerable use to them, as hitherto there were no track charts of the storms in the Arabian Sea for the different months. For the majority of the storms quoted the available materials are admittedly very scanty; nevertheless, the author has been able to draw some useful conclusions from them, with reference to the general behaviour of the storms. The paper is divided into two parts—the first gives the details of each of fifty-four storms in chronological order, the second treats of their geographical distribution and movements according to months and seasons, and the discussion is followed by charts showing the tracks of the storms in the different months. The cyclones are formed on the northern limits of the south-west monsoon; when the northern limits of the monsoon reach the land, and also when the north-east monsoon extends from Asia to the equator, which is the case from December to March, no cyclones are formed over the Arabian Sea. The barometric fall is gradual and equal on all sides, except near the centre, and a depression of 0.25 inch below the average is indicative of the existence of a cyclone in the neighbourhood. When the storms are in confined waters they may burst with great suddenness, but in other cases strong winds are felt for several hundred miles around the centre. The northern parts of the Arabian Sea are liable, during the prevalence of the north-east monsoon, to be disturbed by small cyclonic storms descending from the highlands of Persia and Beluchistan, but the whole of the south-west of the Arabian Sea, though liable to south-west gales during the summer monsoon, and to strong north-east winds during the winter monsoon, is free from cyclones.

DR. STIRLING'S *Notoryctes typhlops*, the lately discovered Australian animal, to which we have repeatedly called attention, forms the subject of an interesting note in the "Hand-List of Australian Mammals," by J. Douglas Ogilby, an advance copy of a portion of which has been forwarded to us. The conclusion at which Mr. Ogilby has arrived, after an exhaustive study of Dr. Stirling's pamphlet, is that in this animal we have at last obtained a definite connecting link between the Monotremes and the Marsupials. At the present stage of our know-

ledge it would, he thinks, be presumptuous to class *Notoryctes* among the Monotremes proper, although several leading naturalists incline to the opinion that its affinities are closer to these mammals than to the Marsupials. He prefers for the present to look upon it as an aberrant Polyprotodont.

THE Institute of Jamaica has issued the first number of a Journal which is to contain, among other things, contributions regarding newly discovered flora and fauna of the island, and articles dealing with botany and kindred sciences. Four parts will be published in the year. In this first number there are excellent notes, by Mr. T. D. A. Cockerell, on the transformation of some Jamaica Lepidoptera. He points out that, although many species of butterflies and moths have been described from Jamaica, the transformations of very few are known.

DR. A. H. POST, the well-known anthropologist, describing in this week's *Globus* various marriage customs, refers to a strange sort of symbolical marriage which is supposed to have originated in India. It is a marriage with trees, plants, animals, or inanimate objects. If anyone proposes to enter upon a union which is not in accordance with traditional ideas, it is believed that the ill-luck which is sure to follow may be averted by a marriage of this kind, the evil consequences being borne by the object chosen. In various regions a girl must not marry before her elder sisters, but in some parts of Southern India the difficulty is overcome by the eldest daughter marrying the branch of a tree. Then the wedding of the second daughter may safely be celebrated. Dr. Post gives several other instances, which are likely to be new to many students of anthropology.

ACCORDING to an official French Report, the copper mines of French Congo are likely to prove of considerable importance. They lie in the district around the sources of the Ludima-Niadi, about two days' journey south of Stéphanieville. The ore is malachite, which is brought to the surface by about 350 negroes. Their methods of work are extremely simple. They reach the malachite by digging out, with implements of hard wood, holes or shafts three feet wide and twice as deep. The malachite is broken on the ground, and afterwards, when pulverized, put into a furnace on a tray with charcoal, on which bellows are made to play. In due time the tray is removed by means of pieces of bamboo, and the metal is poured into sand moulds. The entire district is said to be rich in copper, and masses of malachite are frequently found in the Ludima.

MR. ERNEST E. THOMPSON, of Toronto, contributes to the new volume of the Proceedings of the U. S. National Museum (vol. xiii.) a valuable study of the birds of Manitoba. He gives an enthusiastic description of the music of prairie larks, large numbers of which, at dawn, may be heard in the spring to "burst all together into a splendid explosion of song, pouring out their rich, strong voices from every little height and perch, singing with all their might." They sing all day, and at night joyously hail the moon. As their notes become more complicated, the most casual observer cannot fail to perceive "that the love-fires are kindling, and that each musician is striving to the utmost of his powers to surpass all rivals and win the lady lark of his choice." "On one occasion," says Mr. Thompson, "as I lay in hiding near a fence, three larks came skimming over the plain. They alighted within a few yards of me, and two of them burst into song, sometimes singing together and sometimes alternately, but the third was silent. When at last they flew up, I noticed that the silent one and one of the singers kept together. I had been witness to a musical tournament, and the victor had won his bride."

ANOTHER of the many birds of Manitoba about which Mr. Thompson has something interesting to say is the crane. The

first intimation of its advent in the spring is usually a loud trumpeting or croaking that seems to shake the air for miles. But the cranes themselves, generally in pairs, soon begin to be seen. Their food at that season is chiefly rose-pips, in gathering which they stalk over the bare plains. At first little can be noted but their excessive wariness, but as the warmer weather quickens their feeling, they often "so far forget their dignity as to wheel about and dance, flapping their wings and shouting as they 'honour their partners,' and in various ways contrive to exhibit an extraordinary combination of awkwardness and agility." This dance Mr. Thompson has seen only during the pairing season.

REFERRING to the question "whether squirrels are torpid in winter," Mr. C. Fitzgerald writes in the December number of the *Zoologist* that, during many winters passed in the backwoods of North America, he has seen squirrels frisking among the trees in the coldest weather. On bright sunny days especially they delight in chasing each other from tree to tree among the evergreens, and cover the snow with their tracks. The young of the ordinary red squirrel are born early in the spring. The "Chipmunks," or little striped ground squirrels, lay up in the autumn a store of provisions of grains, nuts, &c., for winter, and on fine days may be seen sunning themselves. Mr. Fitzgerald has on several occasions come across their hoards, and once saw two large bucketsful of shelled buckwheat taken from the hollow of an old birch tree that the woodmen had chopped down on the edge of a clearing which had been cropped the previous summer with that grain.

AT the meeting of the Linnean Society of New South Wales on October 28, the fifth part of Mr. E. Meyrick's "Revision of Australian Lepidoptera" was read. This paper practically concludes the Australian *Geometrina*, except in so far as future discoveries may produce fresh material. One hundred and twelve species are included, of which forty-seven are described as new.

MR. CARL LUMHOLTZ contributes to the current Bulletin of the American Geographical Society a very interesting report on his explorations in Northern Mexico. The most remarkable caves he met with were at the head of the Piedras Verdes River, 6850 feet above sea-level. These caves contain groups of deserted houses or small villages, and the houses are splendidly made of porphyry pulp, and show that the inhabitants had attained a comparatively high culture. The dwellings were sometimes three stories in height, with small windows, and doors made in the form of a cross; and occasionally there were stone staircases. The caves, which number about fifty in a stretch of twenty miles, are from 100 to 200 feet above the bottom of the cañon, and the largest is some fifty feet high. One series of them, on the shady side of the cañon, had been reserved for burial-places. Here, at a depth of three feet, Mr. Lumholtz dug out a number of bodies in a wonderful state of preservation, the saltpetre which is mixed with the disintegrated rock having for centuries preserved them, making them look like mummies. Several had their features, hair, and eyebrows perfect, and these were photographed. The hair is very slightly wavy, and softer than that of the ordinary Indian, almost silky in fact. They were small people, and reminded Mr. Lumholtz strikingly of the present Moqui village Indians. The Moquis, like the Zuñis, have a tradition that they came from the south. The same district abounds in mounds, some of which are very large. Mr. Lumholtz thinks that an explorer might find in these mounds a fine field for investigation. With his own limited force of men he was not able to make as extensive excavations as he wished to make; but still, a good deal of work was done. He unearthed a great many polished stone implements, about 300 jars, most of them

decorated, and some in very odd shapes, and several specimens of a big stone wheel, and a stone cylinder fitting into it, probably used for some sort of game. The mounds contain houses, and, as usual, most of the relics are found near the dead bodies, which are always buried under the floor, partly under the wall. These people must have been there before the arrival of the cave and cliff dwellers, but who they were it would not yet be safe to say.

MESSRS. T. COOKE AND SONS, of Buckingham Works, York, have issued a new illustrated catalogue of telescopes, surveying and other optical instruments.

MESSRS. GURNEY AND JACKSON (Mr. Van Voort's successors) hope to have ready for publication by the end of this year the first volume of "A Synonymic Catalogue of Lepidoptera-Heterocera," which Mr. W. F. Kirby, of the Zoological Department, British Museum, has been for some time engaged upon.

SIR J. D. HOOKER'S well-known book of travels, "Himalayan Journals," has been reprinted in the Minerva Library series (Ward, Lock, Bowden, and Co.). It is reprinted from the first (unabridged) edition, with the omission of some of the appendices, which were only of limited general interest. Mr. Murray has supplied copies of the original woodcuts, many of them from drawings by the author.

A NEW Review, which will be partly scientific, is about to be issued at Rome. It is to be published twice in the month, and will be entitled *Natura ed Arte*.

THE admirable Harveian Oration recently delivered by Dr. W. H. Dickinson has just been published by Messrs. Longmans, Green, and Co.

PART 9 of Cassell and Co.'s "Universal Atlas" has just been issued. It contains a map of the Balkan Peninsula, another of China and Japan, and one of Japan alone, the first occupying a double page.

TWO communications upon phosphides of boron have been published by M. Moissan and M. Besson respectively in the most recent numbers of the *Comptes rendus*. M. Moissan has obtained two compounds of phosphorus and boron of the composition  $PB$  and  $P_2B_3$ , by the reduction of the new compound  $PBI_2$  recently prepared by him (comp. NATURE, vol. xlv. p. 67) in a current of hydrogen gas. M. Besson, however, in July of this year published a note upon one of these compounds,  $PB$ , which he obtained by heating the compound  $BBBr_2.PH_3$  to the temperature of  $300^\circ C$ , and in the current number of the *Comptes rendus* calls M. Moissan's attention to the fact. These compounds of boron and phosphorus appear to be somewhat remarkable substances, and the following is a brief account of their mode of preparation and properties, as described by Messrs. Moissan and Besson. The curious compound  $PBI_2$  is a substance crystallizing *in vacuo* in beautiful bright red crystals. When these crystals are heated in a current of dry hydrogen to a temperature of  $450^\circ-500^\circ$ , three things happen: a small portion of the compound volatilizes unchanged, and forms an annular red deposit upon the cooler part of the tube; another portion loses iodine and yields a second sublimate, yellow in colour, of the other compound of phosphorus, boron and iodine, ( $PBI_2$ ), prepared by M. Moissan; the remainder of the  $PBI_2$  becomes converted *in situ* into the normal phosphide of boron,  $PB$ . The heating of the  $PBI_2$  is best effected in a U-shaped tube immersed in a bath of fused nitre. After the reduction is completed as far as possible, which is determined by the cessation of the evolution of vapour of hydriodic acid, the U-tube is removed from the bath, and the residual phosphide extracted, powdered rapidly, and again placed in the tube, and the reduction continued for a short time longer, in order to insure the removal of the last

traces of iodine. The phosphide of boron thus obtained is a brown powder, very light in texture, and insoluble in every solvent which has yet been tried. In contact with oxygen the compound ignites at a temperature about 200°, and burns with a very brilliant flame, forming boric and phosphoric anhydrides. With chlorine gas it inflames at the ordinary temperature, producing boron trichloride and phosphorus pentachloride. Vapour of sulphur converts it into sulphides of boron and phosphorus. When thrown into a little fused nitre instant incandescence and deflagration occur. Its behaviour with nitric acid is characteristic; it immediately becomes incandescent, and moves rapidly to and fro over the surface of the acid, all the while burning with a most dazzling flame. It reduces concentrated sulphuric acid to sulphur dioxide. Fused potash decomposes it with evolution of phosphoretted hydrogen and formation of potassium borate. Sodium or potassium, in an atmosphere of hydrogen, react upon warming with great energy, the mass becoming white-hot. Magnesium, heated with the phosphide to 500°, also reacts with incandescence. Even silver and copper react violently upon heating with phosphide of boron. Vapour of water decomposes it at 400°, with production of boric acid and phosphoretted hydrogen. Heated to 300° in ammonia gas it takes fire, and burns with formation of nitride of boron and deposition of phosphorus.

THE second compound of boron and phosphorus, P<sub>3</sub>B<sub>5</sub>, was obtained by M. Moissan by heating the compound PB just described in a current of hydrogen to a temperature near 1000°. Under these circumstances a portion of the phosphorus is eliminated, and condenses in drops in the colder part of the tube, leaving the P<sub>3</sub>B<sub>5</sub> in the form of a light brown powder, which is distinguished from the normal phosphide BP by its indifference to chlorine and nitric acid. It is much more stable than the normal phosphide, but is, like the latter compound, decomposed with incandescence by fused nitre.

THE additions to the Zoological Society's Gardens during the past week include a Formosan Fruit Bat (*Pteropus formosus*) from Formosa, presented by Mr. Thomas Perkins, F.Z.S.; a Patagonian Cavy (*Lolichotis patagonica*) from Patagonia, presented by Mr. H. H. Sharland, F.Z.S.; a Blotched Genet (*Genetta tigrina*) from South Africa, presented by Mr. Edmund R. Boyle; a Grey Ichneumon (*Herpestes griseus*) from India, presented by Mr. G. F. Hawker; a Little Grebe (*Tachybaptus alvialitilis*), British, presented by Mr. T. E. Gunn; a Tuatera Lizard (*Sphenodon punctatus*) from New Zealand, presented by Mr. W. King; a Brush-tailed Kangaroo (*Petrogale penicillata*) from New South Wales, purchased; three Carpet Snakes (*Morolia variegata*) from New South Wales, received in exchange.

OUR ASTRONOMICAL COLUMN.

THE SECULAR ACCELERATION OF THE MOON AND THE LENGTH OF THE SIDEREAL DAY.—Laplace showed that the secular diminution of the eccentricity of the earth's orbit ought to produce in the longitude of the moon a term proportional to the square of the time, and which he determined as + 10<sup>6</sup>l<sup>2</sup>, where l is expressed in centuries. Adams and Delaunay have reduced this term to + 6<sup>1</sup>/<sub>2</sub>l<sup>2</sup>. From a discussion of eclipses Airy concluded that the coefficient of acceleration is as much as 12<sup>1</sup>/<sub>2</sub> or 13<sup>1</sup>/<sub>2</sub>; and accepting this, the question arises as to the cause, other than that indicated by Laplace, which will account for the difference of 6<sup>1</sup>/<sub>2</sub>. This forms the subject of a paper by M. Tisserand in *Comptes rendus*, No. 20, 1891. Prof. Darwin found that the tidal action between the earth and the moon was sufficient to furnish an apparent acceleration equivalent to the required complement. The accompanying decrease in the earth's rotational velocity produces an apparent acceleration of 3<sup>3</sup>/<sub>8</sub>l<sup>2</sup> in the case of Mercury, an amount which may make the longitude of the planet vary by as much as 15<sup>1</sup>/<sub>2</sub> in a couple of hundred

years. Since the observed transits of Mercury extend over more than two centuries, M. Tisserand has discussed them with the idea of determining whether the term 3<sup>3</sup>/<sub>8</sub>l<sup>2</sup> is really indicated by them. He finds, however, that the extreme transits are not so well represented with the new term as without it, although the difference is not very great. This result, therefore, is unfavourable to the idea as to the variability of the sidereal day, or at least to a variation sufficient to reconcile the result of Airy's research with the calculations of Adams and Delaunay. This being so, it is concluded that the increase in the length of the day, produced by tidal action, has nearly the same value as the diminution which results from the contraction of the earth caused by secular cooling, and that, on account of the compensating action of the two effects, the length of the sidereal day remains very nearly invariable.

STATE OF SOLAR ACTIVITY.—Prof. Tacchini gives, in *Comptes rendus* for November 30, a résumé of solar observations made at the Royal Observatory of the Roman College during July, August, and September of this year. The number of days of observation were 31 in July, 31 in August, and 19 in September, and the results obtained are as follows:—

1891.	Relative frequency		Relative magnitude	
	of spots.	of days without spots.	of spots.	of faculæ.
July ... ..	18.65	0.00	76.25	82.03
August ... ..	8.84	0.06	49.06	70.81
September ...	17.52	0.00	114.45	61.10

A comparison of these numbers with those determined in the preceding quarter shows that solar activity has sensibly increased, for the spotted surface has twice the area. It will be seen that the minimum magnitude of faculæ occurred at the time of a maximum of spots. The following are the results obtained for prominences:—

1891.	Number of days of observation.	Prominences.		
		Mean number.	Mean height.	Mean extension.
July ... ..	30	8.37	40.2	1.4
August ... ..	30	6.77	41.0	1.9
September ...	23	9.26	41.4	2.2

The number of prominences recorded is greater than during the preceding three months. The highest prominence (142<sup>2</sup>) was observed in August.

OBSERVATIONS OF μ CEPHEI.—Mr. J. E. Gore made some observations of the variable star μ Cephei, the "garnet star" of Sir William Herschel, between January 1888 and December 1890, which show that the variation of light is very irregular, and that the star sometimes remains for several months with little or no perceptible change of magnitude (Proc. Royal Irish Acad., January 26, 1891).

*Astronomische Nachrichten*, No. 3067, contains an account of the investigation, carried out by Herr Dr. Walter Wislicenus on the "Influence of Ring and Disk Blinds in Micrometric Measurements," in order to account for the following phenomenon. If one lifts a transit off its pillars and places it so that it does not interfere with the line of sight of the collimators, and then brings the central wires of each collimator exactly in coincidence, it is found that, by putting the meridional circle back again, and placing it in its vertical position with the apertures in the central cube open, coincidence of the wires no longer exists, but a slight displacement is noticed. It may be remembered that this question was raised at Greenwich as early as the year 1868, while in the two following years, from observations made in that interval, a correction of 0<sup>1</sup>/<sub>4</sub> and 0<sup>1</sup>/<sub>5</sub> was found for the difference of reading. In 1874 this discrepancy was accepted as real, and corrections for it were made, but no real origin for it was assigned. Mr. Turner, in the year 1886, also investigated this difference of reading, employing the collimators of the transit circle at Greenwich, and the numerical results obtained were given in vol. xlvi. p. 329, of the *Monthly Notices*. By using a wooden model of the central cube of the transit, he got essentially the same results as those given by the cube in the ordinary manner, but both were in discordance with the readings taken when nothing was interposed. To account for the difference he says: "The discrepancy is due to a real difference between the lines of collimation of the central and eccentric portions of the object-glasses of the collimators."

In Herr Dr. Wislicenus's experiments, six blinds of varying diameters were employed, and were placed on the cube of the Strassburg meridional circle to represent different central-cone apertures. He measured the difference between the readings taken with and without these blinds on five separate days, in the two positions, horizontal and vertical, of the collimator threads. To still further vary the method, he removed the meridional circle, and placed the blinds on the collimators, making another series of observations, the collimator threads being again in these two positions. From the above measurements he concluded (to state it very briefly): (1) that the differences obtained with the Greenwich circle are of a purely optical nature, and can be easily removed by making the aperture of the central cube somewhat larger than the full aperture of the collimators; (2) and also if the objective of a telescope be screened quite symmetrically by concentric rings or disks, or by such an arrangement as that in the Greenwich instrument, there occurs not only a variation in the focal image as regards sharpness and brightness, but there can also be found the same displacement. In discussing the observations and conclusions arrived at, he mentions that in the best objectives the same colour rays do not combine in a point on the optical axis, but in such a way that one does not obtain a focus but a focal line of unequal brilliancy, from the brightest point of which one deduces the focal plane of the lens; he then goes on to say that since the optical axis of the lens forms therefore an angle with that of the objective, the displacement of the brightest point of the focal line would not fall perpendicular on the focal plane of the lens, but one would have to observe it with the lens somewhat on one side, by this means one would be able to see its projection on the focal plane of the lens. Therefore, "by the existence of a centering-error the displacement of the focal image by the insertion of blinds before the objective would be explained."

THE *Annales* of the University Observatory in Vienna, vol. vii., contains all the observations of planets and comets made in the years 1887-89, with the Fraunhofer's, Clark's, and Grubb's refractors of apertures 16.2 cm., 30.1 cm., and 68.0 cm. respectively, together with the reduced results of the above. In addition to the work mentioned, the Grubb refractor was extensively employed in the study of the nebula in the Pleiades, special attention being given to the *Merope* nebula, which forms the chief topic of discussion in the interesting report towards the end of the volume; an excellent illustration also of the nebula itself is added, in which are shown all the fundamental stars with many others of smaller magnitude.

Of the other illustrations given, there are three very good pictures of the moon, taken with the same instrument. Plate I. is the result of an exposure of 6 seconds taken on an orthochromatic plate, and for sharpness and clearness is excellent. Plate II., which is an enlargement of a part of Plate I. enlarged four times is also very fine. Plates IV., V., and VI., contain drawings of comets and nebulae, and are accompanied with descriptions of their peculiarities.

Altogether this volume is of a most interesting nature, and shows the result of a great amount of painstaking and useful work, which will be welcomed by all astronomers.

### THE EASTERN TAURUS AND ANTI-TAURUS.

AT the meeting of the Royal Geographical Society, on Monday evening, the paper read was on the Passes of the Eastern Taurus and Anti-Taurus, by Mr. D. G. Hogarth.

The paper described the general characteristics, geographical and ethnographical, of the eastern half of the mountain system of Southern Asia Minor, and is based on experience gained by the author in the course of journeys in 1887, 1890, and 1891, undertaken under the auspices of the Asia Minor Exploration Fund, to which the Royal Geographical Society has been a generous contributor. In 1890, Prof. W. M. Ramsay was the head of the Expedition, and though in the other years the author was not accompanied by him, he followed lines which that great authority on Asia Minor had laid down. Mr. H. A. Brown (author of "A Winter in Albania"), the Rev. A. C. Headlam, of All Souls' College, and Mr. J. A. R. Munro, of Lincoln College, Oxford, took part in the expeditions in different years. The first object of the journeys was archaeological, to carry on the brilliant work of Prof. Ramsay commenced in 1881, but the members of the expeditions have always taken geographical

notes and observations in traversing the interior of Asia Minor, about many parts of which less is known in modern than was known in ancient times. In following old trade-routes across the mountains, he explorers have traced the modern tracks, for the limits of ancient and modern geography are very often not to be distinguished in Asia Minor. Much of the peninsula is a land of the dead, but much also possesses great interest in the present, and may be, will acquire an interest of a different kind for England in the near future. It has been explored by many travellers, from Pococke, Hamilton, Leake, and Ainsworth, to the archaeologists who have penetrated it in different directions during the past twenty years, and the trained surveyors, led by Sir Charles Wilson, who did so much geographical work in it ten years ago. But Asia Minor is very large, often very difficult to traverse, and of very varied character, as is to be expected in the meeting-place of so many civilizations and faiths, ancient and modern. Much has yet to be done before western geographers can claim even a superficial knowledge of its whole area, and many parts have never been visited by any explorer at all.

The first district described is the wild mountainous region between the beautiful lakes of Egerdir and Beysheher, remarkable for the absence of passes, for the great gorge of Eurymedon, and for the primitive character of the indigenous population who live cut off from the world. Not less noteworthy are the extraordinary ruins of the Pisidian city of Adada, which exist high up among the hill-tops, and are now called *Kara-Bavlo*, a name which recalls that of St. Paul, and probably is derived from a great church dedicated to the Apostle in commemoration of a sojourn on his way from Perga to Antioch in 45 A.D. These ruins preserve the most perfect specimen of an Anatolian city of Roman days. Passing by the sites of Lystra and Derbe, the Low Taurus is reached, a marked depression between the high inter-lacustrine ranges and the Bulgar Dagh, which begins about 70 miles west of the Cilician Gates (Gulek Boghaz). The waterless, arid character of the northern, and beautiful scenery of the southern slopes, especially in the Calycadnus valley, are described in connection with the routes radiating from Karaman. The remarkable ruins of the monastery of Koja Kalessi, which contain a very perfect church of the early fifth century at the latest, and of the city of Coropissos, add archaeological interest to this section of the Taurus. The eastern part of this region is a veritable Pompeii, where Roman cities, villages, and roads have been left to decay in a deserted country.

The high Taurus is reached near Eregli. The famous defile known as the "Cilician Gates" has been often described, but not so the important passes further east, from Sis to Hadjin and Gyukun; from Marsh to Gyukun, Zeitun, and Albistan; and from Adiaman to Besni and Malatia. The Eastern Taurus is a region of great beauty, richly wooded, and traversed by the tremendous cañons of the Samanti, the Saros, and the Jihan, not passable even on foot. Whenever a railway is made from Asia Minor towards the Euphrates, it will take the gorge of the latter river, which in ancient times was rendered possible for a road. The ethnographical and historical interest of this region is very great, as it formed the refuge of the last independent Armenians of Cilicia, whose robber-towns, Hadjin and Zeitun, are described by the author. Of late their exclusive possession has been disputed by Circassians and Kurds, the latter retaining curious traces of their pre-Islamic rites and customs.

Lastly, the principal passes into the Anti-Taurus from the west, and out on the east in the direction of the Euphrates, are briefly noticed. The Anti-Taurus district is one of the most curious in Asia Minor; man deserted it almost entirely from the eleventh century until less than a century ago, when nomadic Avshar and Kurds penetrated to its remote and lofty valleys. Thus has been preserved so much of the great Roman military road to the Euphrates in the valleys of the Saros and Gyuk Su, with a series of milestones recording its many restorations; to the same cause we owe the interesting ruins of Comana, and "Hittite" monuments, recalling very early days, when a great trade-route, afterwards identical with the Royal Persian road, already took this line. Of different but equal interest are the modern inhabitants, nomadic Avshar, and half-troglodyte Kurds, nominally Musulmans, but really worshippers of other gods than that of Islam; and newly-imported Circassians, settled near troublesome Armenian strongholds as a menace and a check. The medley of races in this remote region, for whose control the Turks seem able to make no adequate provision, suggests speculations as to the possible future of race-supremacy in the Ottoman Empire.

THE ZOOLOGY AND BOTANY OF THE WEST INDIA ISLANDS.<sup>1</sup>

THIS Committee was appointed in 1887, and it has been reappointed each year until the present time.

During the past year Mr. F. DuCane Godman, F.R.S., has continued to employ a collector in the island of St. Vincent, and owing to the valuable assistance thus afforded to the Committee it has been possible to complete the exploration of this island. The collections in zoology are very extensive, and those in botany extend to the whole of the phanerogams and the vascular cryptogams. No expense has been incurred by the Committee in regard to any of these collections in St. Vincent.

The services of Mr. R. V. Sherring, F.L.S., were accepted, as mentioned in the last report, to make botanical collections in the island of Grenada. He left this country in October last, and returned after seven months' absence in June last. Mr. Sherring has forwarded to this country large collections, consisting for the most part of vascular cryptogams, and these are now in course of being determined at Kew. A detailed report on the various collections in zoology and botany received during the past year is given below.

At the present time Mr. Herbert H. Smith, the collector employed by Mr. Godman, is making collections in zoology in the island of Grenada. This is the most southerly of the chain of islands intended to be explored by the Committee. When this island is completed, the Committee will have been engaged in investigating the fauna and flora of most of the islands in the Lesser Antilles lying between Martinique and Trinidad. The islands in which collections have so far been made consist of Dominica, St. Lucia, Barbados, St. Vincent, the Grenadines, and Grenada.

**Zoology.**—Since the last report collections have continued to be received from St. Vincent by Mr. Godman. The work of sorting and arranging these collections has been begun. The arthropods are already completed, and the larger part of the insects is mounted and prepared for despatch to the specialists who have been engaged to work them out.

For this purpose the Committee have been so fortunate as to obtain the assistance of the following naturalists: Herr Hofrath Brunner von Wattenwyl for the Orthoptera; Prof. Riley for the Rhynchota; Mr. Howard for the parasitic Hymenoptera; Prof. S. W. Williston for the Diptera; Prof. Aug. Forel for the Ants; Lord Walsingham for Lepidoptera, part; F. D. Godman and O. Salvin for Lepidoptera, part; D. Sharp for Coleoptera; M. Simon for Spiders generally; Mr. G. W. Peckham for Attidae. The Committee have undertaken to procure publication of the memoirs that may be received from these savants.

A small collection of specimens made by Dr. H. A. Alford Nicholls, F.L.S., local secretary to the Committee in the island of Dominica, was received in May last. This consisted of nine mammals, one lizard, one snake, five fishes, one *Ascalaphus*, twelve Longicornia, two Passalidae, and five Lamellicornia. Besides these Dr. Nicholls sent from the island of Tobago four of the peculiar nests of the yellow-tailed bird of that island (*Cassicus cristatus*). These birds usually build their nests depending from isolated branches of the silk-cotton tree (*Eriodendron anfractuosum*), and they look like huge fruits waving in the wind.

A small collection of Lepidoptera was received in November last from Captain Hellard, R.E., local secretary to the Committee in the island of St. Lucia. The mounted specimens in this collection arrived in bad order, owing to the pieces of camphor getting loose in the boxes and breaking the greater part of them, including almost the whole of the *Sphingide*.

Mr. John C. Wells, who has devoted attention to the ornithology of Grenada, has kindly consented to act as a local secretary for that island.

**Botany.**—Of the botanical collections received from St. Vincent the vascular cryptogams have been determined by Mr. J. G. Baker, F.R.S., and an account of them, with two plates, printed in the *Annals of Botany*, vol. v. (April 1891) pp. 163–172. Amongst the ferns the most striking novelty is a new species of *Asplenium*, named *A. Godmani*, Baker (pl. xi.), found in damp forests at the extreme top of Morne à Garou. Other new species

are *Hymenophyllum vincentinum*, Baker (pl. x.), and *Acrostichum (Elaphoglossum) Smithii*, Baker. The total number of vascular cryptogams found recently in St. Vincent amounts to 168 species. Most of these are widely spread through tropical America, and only four are endemic. In addition to the above a new species of *Hepatica*, also from St. Vincent (*Kantia vincentina*, C. H. Wright), was described in the *Journal of Botany*, vol. xxix. (April 1891), p. 107.

Of the phanerogams from St. Vincent and some of the Grenadines the work of determining these is being carried on as expeditiously as circumstances permit. The collection is a very large one, and the results so far attained are contained in the following memorandum prepared by Mr. R. A. Rolfe:—

The flowering plants have been determined as far as the end of Rutaceae. Those from St. Vincent number slightly over a hundred species, of which about thirty, consisting for the most part of common West Indian plants, were not previously recorded from the island. The most interesting plant is a species of *Trigynaea* (apparently new), a small tropical American genus of Anonaceae not hitherto detected in the West Indies. A *Clusia* and a species of *Tetrapterys*, which cannot be identified, may also prove new. The remainder have been fully determined. The three most interesting of these are *Norantea Jussei*, Tr. and Pl., previously known only from Guadaloupe and Dominica; *Zanthoxylon microcarpum*, Griseb., from Dominica and Trinidad; and *Z. spinosum*, Sw., from Dominica, Jamaica, and Cuba. The composition of the flora of the Lesser Grenadines, situated between St. Vincent and Grenada, was previously almost unknown. The plants hitherto determined are as follows:—From the island of Bequia, 34 species; from Mustique, 18; from Canouan, 5; and from Union, the nearest to Grenada, 5. They are, without exception, common West Indian plants, and are all natives of St. Vincent. From the results hitherto obtained it seems clear that the flora of the Lesser Antilles is tolerably uniform throughout, although the larger islands of Dominica, Martinique, St. Lucia, and possibly St. Vincent, appear to have each a very small endemic element.

The collections made by Mr. Sherring at Grenada consist of nearly 6000 specimens of vascular cryptogams and about 1000 specimens of phanerogams. The number of species of ferns is about 140, and of these two are new, viz. *Asophila Elliottii*, Baker, and *Acrostichum Sherringii*, Baker. The phanerogams have not yet been worked out. Sixty species of ferns were previously known from Grenada from collections made by Mr. G. R. Murray, F.L.S., and Mr. W. R. Elliott. Mr. Sherring has increased this number to 140. The species of greatest interest, other than those known to be new, are *Asplenium Godmani*, Baker, recently found in St. Vincent; *Polypodium Hartii*, Jenman, first described in 1886, and known only in the mountains of Jamaica and Dominica; and *Acrostichum Aubertii*, widely spread in continental America, but new to the West Indies. Other interesting plants collected by Mr. Sherring are *Schizaea fluminensis*, Miers, new to the West Indies, but believed to be only a shade variety of *S. dichotoma*, and *Damea polymorpha*, Leprieur, a critical form of which but little is known.

An account of vascular cryptogams collected at Grenada is in course of being prepared for the *Annals of Botany*.

Mr. Sherring has prepared an interesting report on the flora of Grenada, and this will prove of great interest to students of West Indian botany.

A collection of plants was received from Dr. Nicholls at the same time as the specimens in zoology already noticed. These consisted of fifty-six species of vascular cryptogams—all of them, were, however, well-known West Indian plants—and a small number (175 numbers) of phanerogams. The latter have not yet been determined.

The Committee recommend their reappointment, with the following members: Dr. Sclater, Mr. Carruthers, Prof. Newton, Mr. Godman, Dr. Günther, and Dr. Sharp. The Committee also recommend that the grant of £100 placed at their disposal, but not expended during the current year, be renewed.

## UNIVERSITY AND EDUCATIONAL INTELLIGENCE.

CAMBRIDGE.—Mr. A. E. Shipley, Demonstrator of Comparative Anatomy, has been appointed Secretary to the Museums Syndicate; and Mr. S. F. Harmer, Demonstrator of Invertebrate Morphology, Superintendent of the Museum of Zoology, in the room of Mr. J. W. Clark.

<sup>1</sup> Fourth Report of the British Association Committee, consisting of Prof. Flower (Chairman), Mr. D. Morris (Secretary), Mr. Carruthers, Dr. Sclater, Mr. Thelston-Dyer, Dr. Sharp, Mr. F. DuCane Godman, Prof. Newton, Dr. Günther, and Colonel Feilden, appointed for the purpose of reporting on the present state of our knowledge of the Zoology and Botany of the West India Islands, and taking steps to investigate ascertained deficiencies in the Fauna and Flora.

Dr. William Ewart and Mr. Frederick Treves have been appointed Additional Examiners for the Third M. B. Examination, for which the number of candidates is unusually large.

Candidates for Lord Walsingham's Gold Medal in Biology and Physiology are requested to send in their essays to Prof. Newton by October 1, 1892.

An interesting report on the course of study pursued in Cambridge by the Local Lecture students during the Long Vacation, 1891, appears in the *Reporter* of December 8. Scientific courses on invertebrate palæontology, chemistry, physics, and physiology were given with success in the University Laboratories; while single lectures, with the object of inspiring interest in other departments, were given by Dr. Hill, Dr. D. MacAlister, and Prof. Darwin. Courses in general literature and art were also arranged, and the result of the whole is deemed by the Syndicate so satisfactory that they propose to regard the Long Vacation scheme as part of their regular work. Forty-seven students took advantage of the facilities offered by the University for acquiring a closer knowledge of the subjects they had commenced under the University Extension Lectures.

It is proposed that two new Syndicates shall be appointed—the first, to be called the Engineering Laboratory Syndicate, is to make arrangements for the further development of the Engineering School in the University, and in particular to endeavour to raise funds for its adequate endowment; the second is to consider the establishment of an Honours Examination in Mechanical Science.

#### SCIENTIFIC SERIALS.

THE *Quarterly Journal of Microscopical Science* for June 1891 contains:—On the renal organs of certain Decapod Crustacea, by W. F. R. Weldon (plates xxi. and xxii.). It would appear that the nephro-peritoneal sacs of the Decapoda should be regarded rather as enlarged portions of a tubular system, such as that found in Mysis and in the Thalassinidae, than as persistent remnants of a "coelomic" body-cavity, into which tubular nephridia open.—On the nephridium of Lumbricus and its blood-supply, with remarks on the nephridia in other Chætopoda, by Dr. W. Blaxland Benham (plates xxiii. to xxv.). In this memoir the author settles the nomenclature of the parts of the nephridium and the course of the various regions; details the structure of these regions in Lumbricus; institutes a comparison with the nephridium in other genera; describes the nephrostome or funnel in *Perichæta malamantensis*, n.sp., and some other genera; and describes and figures the vascular supply of the nephridium in Lumbricus and in Arenicola.—Notes on the Naidiform Oligochæta, containing a description of new species of the genera *Fristina* and *Pterostylarides*, and remarks upon cephalization and gemmation as generic and specific characters in the group, by Dr. A. Gibbs Bourne (plates xxvi. and xxvii.).—On *Pelomyxa viridis*, sp.n., and on the vesicular nature of protoplasm, by Dr. A. Gibbs Bourne (plate xxviii.). This new species of *Pelomyxa* was found in the mud of a small tank in the neighbourhood of the Madras Presidency College; it would seem to be about the largest known species of the Lobosa, spread out specimens average one-third of an inch in diameter; the vesicles contained chlorophyll, and were numerous; the protoplasm was densely packed with bacteria, the "crystals" of Greef; the pseudopods were coarse and blunt; no reproductive processes were noted; nuclei and nucleoli were present in numbers.—On the medusæ of *Millepora murrayi*, and on the gonophores of *Allopora* and *Distichopora*, by Dr. Sydney J. Hickson (plates xxix. and xxx.). From specimens from Torres Straits, preserved by Prof. Haddon, the author has determined that the ampullæ described in the hard parts of this *Millepora* by Quèlch are the cavities containing male medusæ. The medusa of *Millepora* is a transformed zooid—that is, it is not from the first modified to bear the spermatium, but it is an ordinary zooid of the colony changed into a medusa after the migration of spermospheres into its ectoderm, which are subsequently developed there; these medusæ escape from the ampullæ before the spermatozoa are matured. The male gonophores of *Distichopora* differ from those of *Allopora*, but the female gonophores of these genera closely resemble one another. The gonophores of the Hydrocorallinæ and Hydromedusæ are carefully compared; those of the former are not degenerate medusæ.—On a red pigment-forming organism, *Bacillus corallinus*, by C. Slater (plate xxxi.).

October 1891 contains:—On immunity against microbes, by Dr. Armand Ruffer, Part 2 (plates xxxii. and xxxiii.). While the first part of this memoir treated of the struggle which takes place in the healthy body between micro-organisms and amoeboid cells, this part details what happens where these organisms have found their way into the tissues of animals. It would be impossible to do justice to the contents of this valuable memoir by an abstract.—On the formation and fate of the primitive streak, with observations on the archenteron and germinal layers of *Rana temporaria*, by Dr. A. Robinson and R. Assheton (plates xxiv. and xxv.). The primitive streak is formed in the frog by concrescence of the lips of the blastopore from behind forwards; the ventral moiety of the primitive streak, shortly after the perforation of the anus, ceases to exist and splits up; the dorsal moiety becomes folded upon itself, like and along with the neural plate, and becomes separated from the skin; it gives rise to the whole of the tail with the exception of the greater part of the skin.—On some points in the histology and development of *Myriothela phrygia*, by W. B. Hardy (plates xxvi. and xxvii.).—On the structure of an earthworm allied to *Nemertodrilus*, Mich., with observations on the post-embryonic development of certain organs, by Frank E. Beddard (plates xxviii. and xxix.).—On some points in the development of *Scorpio fulvipes*, by M. Laurie (plate xl.). The development of this form adds another to the numerous types of development in the Arachnida; it is, as shown by its mode of nutrition, a highly specialized form. There is no doubt that the type of development represented by *Euscorpius* is the more primitive of the two. The chief arguments in favour of this are the remarkable facts of the formation in *Scorpio fulvipes* of a rudimentary amnion, and the formation of yolk-spheres in the earlier stages, and a mass of yolk round which the gut is formed.—Abstract of Maupas's researches on multiplication and fertilization in Ciliate Infusorians, by Dr. Marcus M. Hartog.—On the occurrence of pseudopodia in the Diatomaceous genera *Melosira* and *Cyclotella*, by J. G. Grenfell (plate xli.). The author states that he has found pseudopodia in *Cyclotella kutzingiana*, and in one or two small species of *Melosira*. "At Heyesbury, in Wiltshire, the River Wiley and the brooks were found full of a *Melosira* in small isolated frustules, with long delicate pseudopodia; a good set of *Cyclotellas* with pseudopodia were found at Kew Gardens." In the large pond in the gardens of the Botanical Society of London, frustules of *Melosira* gathered with some specimens of *Archerina boltoni* were found with these pseudopodia; sometimes they were easily seen for a part of their length with a 4 object-glass, but in some cases, as in the diatoms from Kew, they are generally invisible, even when specially looked for." These pseudopodia are best seen on "well dried material," they are fairly stiff, and are non-retractile to ordinary observation. In length they vary, in *Cyclotella* from two and a half to six times the width of the valves; they are very permanent, in specimens kept in water they remained apparently unchanged for months; they are generally fairly straight, but sometimes they branch and sometimes two or three spring from a short thickened base. "As to the use of these pseudopods, and the question why other Diatoms do not have them, the chief point to be remembered is that these little *Melosiras* and *Cyclotellas* occur mainly as isolated frustules, and are [without the power of locomotion. Under these circumstances the pseudopodia serve the purposes of protection, means of attachment, and floats." The author says: "facts point conclusively to the substance of these pseudopodia being protoplasm." It is quite probable that "some kind of cuticle is secreted by the protoplasm." As to the possibility of these growths not being pseudopodia at all, he combats the idea, and institutes a comparison between them and the radiating structures met with in *Archerina* (the reference to Prof. Ray Lankester's description of this very interesting form should be *Q. J. M. Sc.*, vol. xxv., 1885, p. 61), but it will be remembered that Prof. Ray Lankester refers to the "delicate but stiff filaments" in his description of *Archerina*, and only uses the term pseudopodia in a conventional sense. As yet we are not convinced by a perusal of Mr. Grenfell's paper that the Diatoms possess pseudopodia in any sense of this term, or that they have any affinities with the Heliozoa.—A very ably written review, signed by George Bidder, on "Dendy's Monograph of the Victorian Sponges, Part I.," which has just been published at Melbourne, concludes this part and volume xxxii. (N.S.) of the *Journal*. The first part of Dr. Dendy's monograph is devoted to the account of the Calcareous Sponges, a group on which Mr.

Bidder has himself been working at Naples for the last five years. His appreciative remarks on Dendy's researches prove how much of interesting and new matter lies in manuscript in the laboratory at Naples, and leads us to express the hope that Mr. Bidder will soon follow the example of his senior, and give us a monograph of the Calcareo Homocœla of the Gulf of Naples; with more details on the glandular ectoderm.

*Travaux de la Société des Naturalistes de St. Pétersbourg, Section de Zoologie et de Physiologie, tome xxi., livr. 1 (Russian).*—On the influence of temperature, and the distance from the section of a nerve, on its electrical irritability, by B. F. Verigo.—Observations on the *Araneina*, by V. Wagner.—The minutes of proceedings contain several interesting notes: namely, a list of the Bryozoa of the Murman coast of Russia, by M. Khvorostansky, containing eighty-one species; on the blood of some invertebrates, by V. Wagner, from which it appears that it always contains two different kinds of cells—the granulous and coloured ones, and the amoeboid ones or leucocytes, besides some other cells which, however, must be considered as derived from the above two kinds.—M. Shimkevitch's remarks on the artificial incubation of ostriches in the ostrich park at Heliopolis are also worth mentioning.

*Bulletin de la Société des Naturalistes de Moscou, 1891, No. 1.*—On the group of the sillimanite and the part played by aluminum in the silicates, by W. Wernadsky (in Russian, summed up in French). The paper contains, besides the description of the experiments already published in the *Comptes rendus*, a discussion of the facts, which brings the author to the following conclusions: the compounds of silicon with aluminium have an acid reaction; they may be embodied in one group, that of the sillimanite. Some of them are hydrates, and some others are salts of these, or of other possible anhydrides. Polymorphic varieties arise in this group with the change of physical conditions, without any perceptible change in the chemical composition.—On the morphology and classification of the Chlamydomonads, by Prof. Goroshankin (in German, with three coloured plates); being a full monograph on the family, in which the following new species are described: *Chlamydomonas Dr-Baryana*, *C. Perty*, *C. Steinitz*, *C. Kulcinski-kowi*, *C. reticulata*, and *C. Ehrenbergii*.—On some peculiarities in the development and the structure of the skull of *Felobates fuscus*, by A. N. Sewertow.—Note on the *Hipparian crassum*, by Marie Pavloff (French).—On the fossil plant-bearing deposits of East Russia and Siberia, by C. Kosmovsky (in French). The close similarity between the supposed Jurassic fresh-water deposits of East Russia and Siberia and the "Artinsk" series is briefly indicated.

## SOCIETIES AND ACADEMIES.

LONDON.

Royal Society, November 19.—"On the Loci of Singular Points and Lines which occur in connection with the Theory of the Locus of Ultimate Intersections of a System of Surfaces." By M. J. M. Hill, M.A., Sc.D., Professor of Mathematics at University College, London. Communicated by Prof. Henrici, F.R.S.

### Introduction.

In a paper "On the  $c$ - and  $p$ -Discriminants of Ordinary Integrable Differential Equations of the First Order," published in vol. xix. of the Proceedings of the London Mathematical Society, the factors which occur in the  $c$ -discriminant of an equation of the form  $f(x, y, c) = 0$ , where  $f(x, y, c)$  is a rational integral function of  $x, y, c$ , are determined analytically.

It is shown<sup>1</sup> that if  $E = 0$  be the equation of the envelope locus of the curves  $f(x, y, c) = 0$ ; if  $N = 0$  be the equation of their node locus; if  $C = 0$  be the equation of their cusp locus, then the factors of the discriminant are  $E, N^2, C^3$ .

The object of this paper is to extend these results to surfaces.

PART I.—The Equation of the System of Surfaces is a Rational Integral Function of the Co-ordinates and one Arbitrary Parameter.

When there is only one arbitrary parameter, each surface of the system intersects the consecutive surface in a curve, whose equations are the equation of the surface and the equation obtained by differentiating it with regard to the parameter. (These

equations will be called the fundamental equations in this part.) Hence each surface touches the envelope along a curve. It is known that the equation of the envelope may be obtained by eliminating the parameter from the fundamental equations and equating a factor of the result to zero. But it frequently happens that there are other factors of the result (or discriminant) which, when equated to zero, do not give the equation of the envelope.

These factors are connected with loci of singular points. If each surface have one singular point, the locus of all the singular points of the surfaces of the system is a curve. Its equations, therefore, cannot be found by equating a factor of the discriminant to zero. But if each surface of the system have upon it a nodal line, then the locus of the nodal lines of all the surfaces is a surface, and its equation may be found by equating to zero a factor of the discriminant.

The singular points in space, the form of which depends only on the terms of the second order, when the origin of co-ordinates is taken at the singular point, are:—

- (i.) The conic node.
- (ii.) The biplanar node or binode.
- (iii.) The uniplanar node or unode.

It is shown that a surface cannot have upon it a curve at every point of which there is a conic node. Hence there are two varieties of nodal lines to be considered; the first, being such that every point is a binode, may be called a binodal line; and the second, being such that every point on it is a unode, may be called a unodal line.

It is shown that if  $E = 0$  be the equation of the envelope locus,  $B = 0$  the equation of the locus of binodal lines,  $U = 0$  the equation of the locus of unodal lines, then the factors of the discriminant are, in general,  $E, B^3, U^3$ , respectively.

This is the general theorem, but it is assumed in the course of the investigation, when the discriminant is being formed, that the fundamental equations are satisfied by only one value of the parameter at each point on the envelope locus or on a locus of binodal or unodal lines.

The investigation is accordingly carried a step further, and it is shown that if the fundamental equations are satisfied by two equal values of the parameter at points on an envelope locus, or on a locus of binodal or unodal lines, the factors of the discriminant are  $E^2, B^3, U^4$ , respectively.

The geometrical meaning of the condition that the fundamental equations are satisfied by two equal values of the parameter in the case of the envelope is that the line of contact of the envelope with each surface of the system counts three times over as a curve of intersection, instead of twice as in the ordinary case. The meaning of the condition in the case of the loci of singular lines is that each of these loci is also an envelope.

PART II.—The Equation of the System of Surfaces is a Rational Integral Function of the Co-ordinates and two Arbitrary Parameters.

When there are two arbitrary parameters in the equation of the system of surfaces, the equation of the locus of ultimate intersections is found by eliminating the parameters between this equation and the two equations obtained by differentiating it with regard to the parameters. (These equations will in this part of the investigation be called the fundamental equations.)

In general the locus of ultimate intersections is a surface. The exceptional cases in which it is not a surface are enumerated at the end of the paper. These include the case where the equation of the system of surfaces is of the first degree in the parameters. Hence it will be supposed that the degree of the equation of the system of surfaces in the parameters is above the first.

In general, the locus of ultimate intersections possesses the envelope property, and the equation of the envelope is determined by equating the discriminant, or a factor of it, to zero.

If factors of the discriminant exist which, when equated to zero, give surfaces not possessing the envelope property, then these surfaces are connected with loci of singular points.

Now the locus of singular points of a system of surfaces whose equation contains two arbitrary parameters is in general a curve. Hence its equations cannot be determined by equating to zero a factor of the discriminant.

But if every surface of the system have a singular point, then in general its co-ordinates may be expressed as functions of the two parameters of the surface to which it belongs. Hence the locus of the singular points is a surface. It will be proved that it is a part of the locus of ultimate intersections. Hence its

<sup>1</sup> The theorem was originally given by Prof. Cayley, in the *Messenger of Mathematics*, vol. ii., 1872, pp. 6-12.

equations can be obtained by equating to zero a factor of the discriminant.

- Let  $E = 0$  be the equation of the envelope locus,  
 $C = 0$  be the equation of the conic node locus,  
 $B = 0$  be the equation of the biplanar node locus,  
 $U = 0$  be the equation of the uniplanar node locus.

Now at any point on the locus of ultimate intersections—

(I.) *There may be one system of values of the parameters satisfying the fundamental equations.*

In this case there may be envelope, conic node, or biplanar node loci; and the corresponding factors of the discriminant are  $E^2$ ,  $C^3$ ,  $B^3$  respectively.

(II.) *There may be more than one system of distinct values of the parameters satisfying the fundamental equations.*

In this case the effect of the distinct values is additive. Thus if there be  $p$  systems of values at a point on the envelope locus, the factor  $E$  would occur to the  $p$ th power.

(III.) *Two or more systems of values of the parameters satisfying the fundamental equations may coincide.*

The results must be stated differently in the cases (a) where the degree in the parameters of the equation of the system of surfaces is greater than two; (b) where the degree in the parameters of the equation of the system of surfaces is two.

In the case (a) it will be shown that there may be envelope loci in which the envelope has stationary contact with each surface of the system; conic node loci, which are also envelopes; biplanar node loci, in which the edge of the biplanar node always touches the biplanar node locus; and uniplanar node loci: and the corresponding factors of the discriminant are  $E^2$ ,  $C^3$ ,  $B^4$ ,  $U^6$  respectively.

The case (b) always falls under the next case—

(IV.) *The values of the parameters satisfying the fundamental equations may become indeterminate.*

If the equation of the system of surfaces be of the second degree in the parameters, and the analytical condition hold which expresses that the fundamental equations are satisfied by two coinciding systems of values, then this condition requires to be specially interpreted. For now the second and third fundamental equations are of the first degree in the parameters, so that if they are satisfied by two coinciding systems of values, they must be indeterminate.

It is, however, possible to determine a *single* system of values of the parameters satisfying them. In this case the three surfaces represented by the fundamental equations intersect in a common curve (which is fixed for fixed values of the parameters) lying on the locus of ultimate intersections; whereas in the previous cases they intersect in a finite number of points lying on the locus of ultimate intersections.

The surface of the system, corresponding to the fixed values of the parameters, touches the locus of ultimate intersections along the above-mentioned curve.

In general, there are *two* conic nodes of the system at every point of the locus of ultimate intersections. The parameters of the surfaces having the conic nodes are determined by two quadratic equations, called the parametric quadratics; and in general the roots of *each* parametric quadratic are *unequal*. In this case the corresponding factor of the discriminant is  $C^2$ . If the roots of *both* parametric quadratics are *equal*, the two surfaces having conic nodes are replaced by one surface having a biplanar or uniplanar node. In this case the corresponding factors of the discriminant are  $B^3$ ,  $U^4$ , respectively.

If the parameters of *one* of the surfaces having a conic node become *infinite*, this surface may be considered to disappear, and there is but one conic node at each point of the locus of ultimate intersections. In this case the corresponding factor of the discriminant is  $C^2$ .

If the parameters of *both* surfaces having conic nodes become *infinite*, both these surfaces may be considered to disappear, and the locus of ultimate intersections is an envelope locus (touching each surface of the system along a curve). In this case the corresponding factor of the discriminant is  $E^3$ .

If the parameters of *both* surfaces having conic nodes become *indeterminate*, then there are at each point an infinite number of biplanar nodes, and each surface of the system has a binodal line lying on the locus of ultimate intersections. In this case the corresponding factor of the discriminant is  $B^4$ .

Physical Society, November 20.—Prof. W. E. Ayrlton, F.R.S., President, in the chair.—Dr. Philippe A. Guye gave a short account and discussion of the various forms which have

been given to the general equation expressing the behaviour of liquids and gases under different conditions of volume, temperature, and pressure, by Van der Waals, Clausius, Sarrao, Violi, Heilborn, and Tait. He first considered the equation of Van der Waals, which, although only an approximation to the true one, may be made to lead to numerous important deductions. He then showed that, of the various more exact formulæ proposed, that of Sarrao is the simplest, and may be used with less expenditure of time and trouble than any of the others. In conclusion, he insisted on the necessity of experimental researches as the only means of arriving at a definite conclusion as to which of the various formulæ is the true one; such researches should involve determinations, as exact as possible, of the critical constants, and of isotherms at high temperatures and great pressures. Prof. Ramsay inquired whether the constants in the formula of Clausius had any physical meaning, or were they merely numbers? M. Guye, in reply, said that, although *some* of the constants in the improved formulæ had no physical interpretations, Van der Waals's equation was the only one in which all the constants had precise physical significations. Prof. Rücker said it was only necessary to look at the formulæ to see how important a factor Van der Waals's expression had been in later developments of the subject. Although it did not agree with experiment under all conditions, particularly at small volumes, yet it was a close approximation over a considerable range, and was the only formula in which all the constants had definite physical meanings. Prof. Tait had pointed out that the number of constants were too few to fully represent the facts, for, by following Andrews's reasoning, he had shown that about the critical point a straight line cuts the isotherm in five points. Nevertheless, during the last twenty years all the so-called improved formulæ were modifications of Van der Waals's expression, and this, he thought, showed how valuable the original formula was. Prof. Fitzgerald said he once tried how far Clausius's formula agreed with the experimental results published by Messrs. Ramsay and Young, and after several months' work, relinquished it on account of the tremendous labour involved. He thought that such complicated formulæ retarded rather than advanced science; simple ones (even if less accurate) were likely to lead to greater advancement. Prof. Carey Foster remarked that the expression  $pV = RT$ , which is nearly true for gases, was the starting-point of all subsequent advances. Van der Waals had arrived at a still closer approximation by taking into account the volume occupied by the particles and their mutual pressure. The President said Van der Waals's memoir had been adversely criticized because of its supposed insufficient recognition of Andrews's investigations on the subject. Better acquaintance with the work had, however, shown this criticism to be undeserved.—Dr. C. V. Burton read a paper on a new theory concerning the constitution of matter. It is assumed that it is possible to have in the ether a distribution of strain which is itself in equilibrium. Such a distribution is called a "strain-figure." An atom is looked upon as an aggregation of strain-figures, the possible varieties of strain-figures (and hence of atoms) being limited by the conditions of equilibrium, and the sizes of possible strain-figures dependent on the coarse-grainedness of the turbulent motion or other structure of the ether. The motion of matter is considered to be merely the transference of a strain distribution from one portion of the ether to another. This the author illustrated by causing a loop to travel along a rope, the loop being regarded as a strain distribution which is propagated along the rope, whilst the rope itself is not transferred. Such transference may occur without encountering any resistance, and the strain-figure will retain the same form, provided the velocity is small compared with that at which gravitation is propagated. The equations of motion of a strain-figure are deduced, and are shown to be identical with those of ordinary matter, provided certain conditions of symmetry are realized. It is also shown under what conditions an atom consisting of strain-figures would have a finite number of degrees of freedom, and some attempt is made to examine how gravitation and other attractions might follow from a distribution of stress in the strained ether. An inquiry is also made into the reason why elements have fixed properties, and their transmutation is discussed. Prof. Fitzgerald, referring to the elastic-solid theory of the ether, said Sir W. Thomson's more recent papers had thrown considerable doubt upon it. The propagation of strain-figures was, he thought, a case of wave motion. In his lectures he had likened the passage of matter through space to that of a drop of water through ice, the ice in front melting, and the rear



of the drop freezing as the liquid state progressed. Many points raised in the paper were, he said, very interesting, and the suggestion that the discrete nature of atoms is the result of the coarse-grainedness of matter, very good. On the other hand, he considered the static treatment of strain-figures improper, for the ultimate conditions must be kinetic. Dr. O. Lodge agreed with Prof. Fitzgerald in regarding the motion of the loop along the rope as a wave motion whose velocity of propagation is equal to that of the loop. A similar case occurs when a ring of rope is spinning, and has a pulse impressed on it at one point, for the pulse travels at the same speed as the rope.—A paper on a permanent magnetic field, by Mr. W. Hibbert, was postponed until next meeting.

**Royal Microscopical Society, November 18.**—Dr. R. Braithwaite, President, in the chair.—A special meeting was first held, at which certain alterations in the by-laws were proposed by the Council, and accepted by the Fellows. The ordinary meeting was then constituted.—Mr. C. L. Curties exhibited and described a small heliostat made on the lines laid down by Mr. Comber. It was simple and effective, and was adapted for use in any latitude between 15° and 70°.—Mr. J. W. Gifford read a paper on the resolution of *Amphipleura pellucida*. Mr. Gifford said he had examined a frustule of *A. pellucida* with sodium light illumination, that being the most convenient form of monochromatic light at the time. Under this light *A. pellucida* unmistakably showed dots, which became more marked as the frustule was shifted to the side of the field of vision. The question then arose as to the possibility of photographing the object by the light of the sodium flame, and plates treated with an erythrosine bath were used. It occurred to him that a trough containing a solution of iron perchloride used as a screen would cut off all the blue end of the spectrum, and also some of the green, leaving only the green yellow, yellow and red; but on the other hand, he found the erythrosine plates were only sensitive as far down as the yellow, more especially to the green-yellow. In this way the part of the spectrum used for photographing could be reduced to a narrow band about midway between the D and E lines in the solar spectrum. By this means he succeeded in obtaining the photographs exhibited, and which he had avoided touching up. Whether these markings were true or spurious was a question he did not touch, but they appeared to have as good a claim as those on *Surirella gemma*. He thought it more probable that in both cases they were simply multiplied rings of the midrib and sides produced by the higher order of diffraction spectra according to the Abbe theory. The mounts of *A. pellucida* used were of realgar, or rather a higher sulphide of arsenic, prepared by mixing sulphur with realgar. He found it extremely difficult to make mounts with such a large proportion of realgar. The mounts being of a deep orange colour inclining to red, enabled the coloured screen to be dispensed with. But this highly refracting medium very soon cracks off the cover-glass. The advantage of working with this form of illumination and a suitable colour-correct plate is that ordinary achromatic object-glasses perform almost as well as apochromatic. He could not see the beaded markings with any glass of less aperture than 1/4; the best results being obtained with Powell and Leland's apochromatic  $\frac{1}{4}$  of 1.5, also with their achromatics  $\frac{1}{4}$  of 1.5 and  $\frac{1}{4}$  of 1.43. He also used in photographing a Zeiss projection ocular.—Mr. E. M. Nelson, speaking of the value of drawings made with Beale's neutral tint reflector, said he had tested the matter by making a drawing of lines on a micrometer scale of 1/30 mm. under an apochromatic objective giving a magnifying power  $\times 850$ ; he found on measuring that they showed only a very slight displacement.—Mr. Curties exhibited a new form of microscope made on the Nelson model.—Mr. Nelson described some improvements in his apparatus for producing pure monochromatic light for use with the microscope.—Mr. A. W. Bennett gave a résumé of his paper on the fresh-water Algae of South-west Surrey, in which he describes several new species.

## CAMBRIDGE.

**Philosophical Society, November 9.**—Dr. Gaskell in the chair.—The following communications were made:—On a *Peripatus* from Natal, by Mr. A. Sedgwick.—On variations in the colour of cocoons (*Saturnia carpinii* and *Eriogaster lanestris*), with reference to recent theories of protective coloration, by Mr. W. Bateson. The cocoons of several moths, e.g. the emperor and small egger, vary in colour from dark brown to white. It is believed by some that these colours have a protective value as a means of concealment, and fit has been

stated by Poulton and others that when spun on leaves which will turn brown, or in dark surroundings, the cocoons are dark, while they are white if spun on white paper. To account for this phenomenon "the existence of a complex nervous circle" has been assumed. The present experiments showed that it is true that larvae left to spin on their food-leaves produce dark cocoons, and also that if they are taken out and put in white paper the cocoons are white. But it was found that larvae similarly taken out and made to spin in dark substances also spun white cocoons, and indeed that starvation, parasites, or interference at the time of spinning, lead to the production of a white cocoon. On the contrary, if white paper is put amongst the food, so that the larvae can, of their own choice, walk into it and spin, the cocoons are generally dark. It was noticed in several cases that larvae which had been shut up evacuated a quantity of dark juice having the natural tint of the cocoon, and the suggestion was hazarded that absence of colour in the cocoon perhaps results from the loss or retention of this juice, which may be of the nature of meconium.—Exhibition of *Phylloxera vastatrix*, by Mr. A. E. Shipley.—On digestion in *Amnocoetes*, by Miss R. Alcock (communicated by Dr. Gaskell).—On the reaction of certain living cells to methylene-blue, by W. B. Hardy.—The chair was taken by Prof. Hughes during the reading of the last two papers.

## PARIS.

**Academy of Sciences, November 30.**—M. Duchartre in the chair.—The reclaiming and cultivation of land in the Camargue, by M. Chambréant. A description of the irrigation, cultivation, procuring of potable waters, and means of transport, introduced in the Camargue. This district is contained between two branches of the Rhone, 50 and 58 kilometres long respectively, which reach the sea at points about 40 kilometres from each other. The bifurcation occurs at Arles, about 50 kilometres from the coast. At the beginning of this century the land was absolutely unfertile, and the inhabitants were unprovided with potable water. The author states the success that has attended the efforts that have been made to remedy this state of things, and bring the land under cultivation.—Observations of the asteroid discovered by M. Borrelly, at Marseilles Observatory, on November 27, 1891, by M. Borrelly. The positions are given for November 27 and 28.—Résumé of solar observations made at the Royal Observatory of the Roman College, during the third-quarter of 1891, by M. P. Tacchini. (See Our Astronomical Column.)—On the tides of the Bay of St. Malo, by M. Heurtault. The author has made tidal observations at St. Malo for the last eighteen years, and states some of the results. The mean monthly level of the sea appears to have a minimum value in April and a maximum in October. The mean annual level increased gradually from 1874 to 1883, and has since been diminishing. The establishment of the port also indicates similar variations. Thus it passed from 6h. 55m. in 1874 to 6h. 10.24m. in 1884, and has since exhibited a tendency to diminish. Its months of maxima are April and September, and of minima July and December, the general mean being 6h. 8.9m. Contrary to Laplace's statement—"Plus la mer s'élève lorsqu'elle est pleine, plus elle descend en basse mer suivante"—it has been found from observations of 45 tides, that in only 25 did the lowest sea follow the highest tide; 3 times it immediately preceded, and 17 times it occurred two tides before.—Phosphides of boron, by M. A. Besson. The preparation and properties of boron phosphide, PB, are described; the possible existence of a more stable compound is also indicated.—On the bromine derivatives of methyl chloride, by M. A. Besson. The compounds CH<sub>2</sub>BrCl and CHBr<sub>2</sub>Cl have been prepared. The author has not yet succeeded in isolating CBr<sub>3</sub>Cl. (1) The compound CH<sub>2</sub>BrCl is a colourless liquid distilling without decomposition at + 68°, solidifying at - 55°; its specific gravity is 1.90. (2) CHBr<sub>2</sub>Cl boils between 117° and 119°, and solidifies at - 32°.—On a modification of the calorimetric bomb of M. Berthelot, and upon the industrial determination of the calorific power of combustibles, by M. Pierre Mahler.—On the fixation of free nitrogen by plants, by MM. Th. Schloesing, Jun., and Em. Laurent. The conclusions drawn from the data obtained are the following:—(1) There are some inferior green plants capable of fixing gaseous nitrogen. (2) Under the conditions of experiment peas take up much atmospheric nitrogen, whereas fallow soils, oats, mustard, cress, and spurry are not capable of fixing a measurable quantity. The paper has remarks by M. Berthelot appended.—The ammonia in the atmosphere and in the rain of

a tropical region, by MM. V. Marcano and A. Muntz. The observations were made at Caracas, in the Gulf of Venezuela, lat.  $10^{\circ} 3' N.$ , altitude 922 metres. An examination of twenty samples of rain gave a mean proportion of ammonia of 1:58 milligram per litre, with a minimum of 0.37 and a maximum of 4.01. The proportion of gaseous ammonia present has been determined by exposing a known surface of acidulated water to the air and observing the ammonia absorbed in a certain time. Eleven determinations, extending over 174 days, have been made, and they show that, on the average, an acid surface of 1 mq. absorbed, in twenty-four hours, 12.52 mgr. of ammonia, with a minimum of 5.30 mgr. and a maximum of 27 mgr. It appears, therefore, that the air of the tropical station is not so rich in gaseous ammonia as that of temperate regions.—Influence of the sun's rays on the bacilli of fermentation found on the surface of grapes, by M. V. Martinand.—On some effects of the parasitism of plants, by M. A. Magnin.

## DIARY OF SOCIETIES.

LONDON.

THURSDAY, DECEMBER 10.

ROYAL SOCIETY, at 8.30.—In a Compensated Air-Thermometer: H. L. Callendar.—Note on the Necessity of using Well-annealed and Homogeneous Glass for the Mirrors of Telescopes: A. A. Common, F.R.S.—On some of the Properties of Water and of Steam: Prof. Ramsay, F.R.S., and Dr. Young.—On the Surya Siddhanta (Hindoo Astronomy): W. Brennan.—Reputation and Rotation produced by Alternating Electric Currents: G. T. Walker.

MATHEMATICAL SOCIETY, at 8.—The Equations of Propagation of Disturbances in Gyrostatically-loaded Media: Dr. J. Larmor.—Theory of Elastic Wires: A. B. Esser, F.R.S.—Researches in the Calculus of Variations: II. Discrimination of Maxima and Minima Solutions when the Variables are connected by Algebraical Equations, the Limits being supposed Fixed: E. P. Culverwell.

INSTITUTION OF ELECTRICAL ENGINEERS, at 8.—Annual General Meeting.—Election of Council and Officers.—On the Specification of Insulated Conductors for Electric Lighting and other Purposes: W. H. Preece, F.R.S.

LONDON INSTITUTION, at 7.—An Hour with my Mozart Manuscripts (Illustrated): Prof. Bridge.

CAMERA CLUB, at 8.—A Short Description and Demonstration of New Telescopic Lens for Photography: T. R. Dallmeyer.—The Use of the Lantern for Scientific Illustration: T. A. H. Finson.

FRIDAY, DECEMBER 11.

ROYAL ASTRONOMICAL SOCIETY, at 8.

INSTITUTION OF CIVIL ENGINEERS, at 7.30.—Meters for Recording the Consumption of Electrical Energy: C. H. Wordingham.

CAMERA CLUB, at 8.—Retouching Class.

SATURDAY, DECEMBER 12.

ROYAL BOTANICAL SOCIETY, at 3.45.

SUNDAY, DECEMBER 13.

SUNDAY LECTURE SOCIETY, at 4.—The Origin and History of the Thames (with Oxlydrough Lantern Illustrations): Prof. J. F. Blake.

MONDAY, DECEMBER 14.

SOCIETY OF ARTS, at 8.—The Pigments and Vehicles of the Old Masters: A. P. Laurie.

ARISTOTELIAN SOCIETY, at 8.—The True Sense of the Term *a priori*: J. H. Muirhead.

LONDON INSTITUTION, at 5.—Tropical Plants and Flowers (Illustrated): D. Morris.

CAMERA CLUB, at 8.30.—Development: Lyonel Clark.

TUESDAY, DECEMBER 15.

ROYAL STATISTICAL SOCIETY, at 7.45.—Enumeration and Classification of Paupers and State Pensions for the Aged: Charles Booth.

UNIVERSITY COLLEGE BIOLOGICAL SOCIETY, at 5.15.—The Sources of Nitrogenous Food of Leguminous Plants: H. Thompson.

INSTITUTION OF CIVIL ENGINEERS, at 8.—The Sale of Water by Meter in Berlin: Henry Gill. (Discussion).

WEDNESDAY, DECEMBER 16.

SOCIETY OF ARTS, at 8.—Typological Museum, as Exemplified by the Pitt Rivers Museum at Oxford: General Pitt Rivers.

ROYAL METEOROLOGICAL SOCIETY, at 7.—Report on the Thunderstorms of 1888 and 1889: William Marriott.—On the Prevalence of Fog in London during the Twenty Years 1871-90: Frederick J. Brodie.

ROYAL MICROSCOPICAL SOCIETY, at 8.—On the Resolution of Podura: Hon. J. G. F. Verker.

INSTITUTION OF CIVIL ENGINEERS, at 2.—Students' Visit to the Stations of the Westminster Electric Supply Corporation, 11 Millbank Street, and Eccleston Place, S.W.

CAMERA CLUB, at 8.—Retouching Class.

THURSDAY, DECEMBER 17.

ROYAL SOCIETY, at 4.30.

LINNEAN SOCIETY, at 8.—Development of the Head of the Imago of Chironomus: Prof. L. C. Miall and A. R. Hammond.—On Two Species of Cumeana in New Zealand: G. M. Thomson.

CHEMICAL SOCIETY, at 8.—The Composition of Cooked Vegetables: Miss K. Williams.—On some Metallic Hydrosulphides: S. E. Linder and H. Picton.—On the Physical Constitution of some Solutions of Insoluble Sulphides: Harold Picton.—Solution and Pseudo-solution: H. Picton and S. E. Linder.—The Change proceeding in Acidified Solutions of Sodium Thiosulphate when the Products are retained within the System; and the Action of Sulphurous Acid on Flowers of Sulphur: Dr. A. Colefax.—The  $\alpha$  and  $\beta$  modifications of Chlorobenzene Hexachloride: Dr. Matthews.—Camphrene, a Product of the Action of Dehydrating Agents on Camphor: Drs. Armstrong and Kipping.—Studies on the Dibromonaphthalenes: Dr. Armstrong and Mr. Rossiter.

NO. 1154, VOL. 45]

LONDON INSTITUTION, at 6.—Winchester Cathedral (illustrated): Very Rev. the Dean of Winchester.

CAMERA CLUB, at 8.30.—Simplified Collographic Process (Description and Demonstration): Leon Warnerke.

FRIDAY, DECEMBER 18.

PHYSICAL SOCIETY, at 5.—On Interference with Alternating Currents: H. Kilgus.

CAMERA CLUB, at 8.—Retouching Class.

## BOOKS, PAMPHLETS, AND SERIALS RECEIVED.

BOOKS.—The Universal Atlas, Part IX. (Cassell).—The Power which Propel and Guide the Planets: S. Laidlaw (Kegan Paul).—Progressive Mathematical Exercises, First Series: A. T. Richardson (Macmillan).—The Principles of Chemistry, 2 vols.: D. Mendeleeff; translated by G. Kamensky; edited by A. J. Greenaway (Longmans).—Lehrbuch der Vergleichenden Entwicklungsgeschichte der Wirbellosen Thiere, Specielle Theil, Zweites Heft: Dr. E. Korschelt and Dr. K. Heider (Jena, Fischer).—Proceedings of the American Association, August 1890 (Salem).—Oriental Cicadidae, Part 4: W. L. Distant (London).—Annalen der k.k. Universitäts-Sternwarte in Wien, Band vii. (Williams and Norgate).—Travels in Africa during the Years 1820-1831; and France: translated by A. H. Keane (Chapman and Hall).—An Essay on Reasoning: E. T. Dixon (Cambridge, Deighton).—Proceedings of the U.S. National Museum, vol. xiii., 1890 (Washington).—An Introduction to Chemical Theory: Dr. A. Scott (Black).—Himalayan Journals: Sir J. D. Hooker (Ward, Lock).—Falling in Love, &c.: Grant Allen; new edn.; (Smith, Elder).—Nature and Man in America: N. S. Shaler (Smith, Elder).—Annuaire 1891, par le Bureau des Longitudes, Paris (Gauthier-Villars).—Connaissance des Temps ou des Mouvements Célestes, 1893 (Gauthier-Villars).—Ephémérides des Étoiles de Culmination Lunaire et de Longitude pour 1891: M. M. Lecwy (Gauthier-Villars).—The Harveian Oration on Harvey in Ancient and Modern Medicine: Dr. W. H. Dickinson (Longmans).—The Cause of an Ice Age: Sir R. S. Ball (Kegan Paul).—Scientific Results of the Second Yarkand Mission—Introductory Note and Map, 1878-91.—Scientific Results of the Second Yarkand Mission—Aves: Dr. R. B. Sharpe (Taylor and Francis).—Animal Sketches: C. Lloyd Morgan (Arnold).—A Manual of Physics: Dr. W. Peddie (Baillière).—Memory, its Logical Relations and Cultivation: Dr. F. W. Edridge-Green; 2nd edition (Baillière).

PAMPHLETS.—Connaissance des Temps. Extrait pour l'an 1892 (Paris, Gauthier-Villars).—Australian Museum, Sydney; Hand-List of Australian Mammals: J. D. Ogilby (Sydney).—Compass-Deviation; Syllabus of Examination in the Laws of Deviation (Imray).

SERIALS.—Records of the Australian Museum, vol. 1, No. 9 (Sydney).—North American Fauna, No. 5 (Washington).—Proceedings of the Academy of Natural Sciences of Philadelphia, 1891, Part 2 (Philadelphia).—Brain, Parts 54 and 55 (Macmillan).

## CONTENTS.

	PAGE
German Technology for English Manufacturers.	
By Prof. T. E. Thorpe, F.R.S. . . . .	121
Diphtheria . . . . .	123
The New York Mathematical Society . . . . .	124
Our Book Shelf:—	
Monteiro: "Delagoa Bay: its Natives and Natural History" . . . . .	124
Sadtler: "A Hand-book of Industrial Organic Chemistry" . . . . .	125
Richardson: "Progressive Mathematical Exercises." . . . .	125
W.	
Letters to the Editor:—	
The Implications of Science.—Edward T. Dixon . . . . .	125
The Koh-i-Nur.—Dr. V. Ball, F.R.S. . . . .	126
Pfaff's "Allgemeine Geologie als Exacte Wissenschaft."—J. J. Gelyne . . . . .	126
Seismometry and Engineering in Relation to the Recent Earthquake in Japan. By Prof. John Milne, F.R.S. . . . .	127
Further Researches upon Azoimide, N <sub>2</sub> H. By A. E. Tutton . . . . .	127
Beast and Man in India. (Illustrated.) . . . .	131
On an Optical Proof of the Existence of Suspended Matter in Flames. By Sir G. G. Stokes, F.R.S. . . . .	133
Notes . . . . .	134
Our Astronomical Column:—	
The Secular Acceleration of the Moon and the Length of the Sideral Day . . . . .	137
State of Solar Activity . . . . .	137
Observations of $\mu$ Cephei . . . . .	137
The Eastern Taurus and Anti-Taurus. By D. G. Hogarth . . . . .	138
The Zoology and Botany of the West India Islands . . . . .	139
University and Educational Intelligence . . . . .	139
Scientific Serials . . . . .	140
Societies and Academies . . . . .	141
Diary of Societies . . . . .	144
Books, Pamphlets, and Serials Received . . . . .	144

THURSDAY, DECEMBER 17, 1891.

## TWO ZOOLOGICAL TEXT-BOOKS.

*Text-book of Comparative Anatomy.* By Arnold Lang, Professor of Zoology in the University of Zürich. Part I. Translated into English. (London: Macmillan and Co.)

*Lehrbuch der vergleichenden Entwicklungsgeschichte der Wirbellosen Thiere.* Von Dr. E. Korschelt und Dr. K. Heider. Parts I. and II. (Jena: Fischer.)

THERE can be no doubt that the first-named of these two treatises, containing, as it does, a number of new engravings and process-cuts, and a recognition and exposition of some of the recent advances in zoological science relating to Invertebrata, will be useful to junior students in our Universities.

Whilst it will, no doubt, fulfil the author's purpose, and have a measure of success in its original German form, I must confess that it does not appear to me to be altogether satisfactory, whether we view it as an elementary sketch for junior students or as a work designed to assist the serious devotee of zoological research.

The most serious defect in the book from the latter point of view is that no attempt whatever is made to refer a given statement to the author who is responsible for it. A very short bibliography is appended to each chapter, but the reader of the book receives no assistance in tracing a new or striking observation to an original source. This curious reticence as to original authorities is carried to an extreme. For instance, on p. 137 there is a brief description (without figures) of *Cœloplana* and *Ctenoplana*; Korotneff is alluded to anonymously as "the discoverer of *Ctenoplana*"; neither his name nor that of Kowalewsky, the discoverer of *Cœloplana*, are mentioned; and the student has no means afforded him, either through the text or through the scanty bibliography, of finding out anything more as to these two remarkable forms. The same defect characterizes every page of the book; a very little trouble would have sufficed to remedy this, and thus not only to make the book useful to students but also to do justice and honour to those whose statements and observations Prof. Lang uses in order to build up his treatise.

The exact classification adopted by a writer nowadays, in so far as zoology is concerned, is to a large extent a matter of taste. One cannot expect to find oneself in agreement with a colleague on all matters of the kind. Prof. Lang is an authority on the Platodes or flat-worms, and I am glad to see that he assigns them a distinct position as an independent "phylum" of the animal kingdom; but I think that he has seriously injured the usefulness of his work by recognizing the "Vermes" as a phylum, including in it such diverse groups as the Nemertina, the Nemathelminths, the Annulata, the Proso-pygia, the Rotatoria, and as an appendage (why an appendage when we have already such a mixed lot?) the Chaetognatha. Prof. Lang, after doing this, proceeds to condemn his own action by stating that the so-called phylum of Vermes "is by no means a natural, well-demarcated division of the animal kingdom; now, as heretofore, it is like a lumber-room, to which all those

groups are relegated which cannot be placed elsewhere." Prof. Lang was not compelled to maintain this ridiculous lumber-room. The consequence of doing so is that he is unable to treat any of the included classes fairly, and that some of the most important problems in morphology are tacitly assumed as solved, or are withheld from the student's consideration. Under the heading "Blood-vascular System," in the chapter on Vermes, we find brought together, and treated as though morphologically identical structures—(1) the canal system of the Nemer-tines; (2) the sub-cuticular network of the *Acanthocephala*; (3) the sinuses, vessels, and capillaries of the Leeches; (4) the closed vascular system of Chaetopods; (5) the tentacular vessels of Sipunculids; (6) the red-corporculated vascular system of Phoronis; and (7) the unexplored vascular systems of Brachiopods. Neither the method of juxtaposition adopted nor the space given permits the author to discuss whether any two of these so-called "blood-vascular systems" are homologous with one another, or whether any one of them is entitled to the name at all. It seems to me that, whilst senior students will be disappointed by the absence of any attempt to deal with the difficult problem of the real nature of the canals and their contained fluids in the cases of Nos. 1 and 3, the junior student will be seriously misled by the easy assumption that any system of canals in the so-called "Vermes" may be called "a blood-vascular system," and is homologous with any other, and with the standard blood-vascular system, viz. that of man. The entire chapter on the Vermes seems to me to be misleading, owing to the author's attempt to deal in a few pages with a number of very different but important groups under this unfortunate heading.

I need hardly say that I am sorry that Prof. Lang adheres to the old view (p. 540) that "the Arachnoidea are not nearly related to the Xiphosura and fossil Gigantostraca, but are racially connected with the Antennata, and are to be considered as Tracheata which have lost their antennæ." It is perhaps only natural that I should distrust the judgment of a zoologist who can at the present day maintain the above propositions. However much I may admire his original work on the Planarians, I cannot consider him a good general guide for the student of zoology. Though I regret Prof. Lang's opinion on this subject, I am not surprised at it, for, in the statement which follows his expression of opinion, he gives a one-sided and erroneous summary of the facts which he thinks can be adduced on either side of the question. Here, as so often elsewhere in the book, one notes the injustice done by Prof. Lang in not citing the name and the work of the author whom he is imperfectly quoting. The student who reads what Prof. Lang has to say on the relationship of the Arachnida to Limulus and the Eurypterines will be misled as to the mere facts of the case, and will not be helped by any reference towards obtaining a fuller knowledge of this interesting matter.

Though many of the illustrations are excellent, Prof. Lang's book cannot be recommended to English readers either for its originality or for its faithful exposition of contemporary knowledge.

The translation appears to be fairly well executed, though the word "apparati," on p. 268, and the repeated

use of "Disconanthæ" and "Siphonanthæ," in place of "Disconanthæ" and "Siphonanthæ," are astonishing, when we note that the translator is M.A. of the University which refuses to inquire whether "compulsory Greek" is useful or not.

A very different work from Prof. Lang's is the treatise on the embryology of the Invertebrata by Drs. Korschelt and Heider, of the University of Berlin, of which an English translation is in preparation. Two parts of this admirable book have appeared, containing 900 pages and more than 500 woodcuts, dealing with the embryology of the Porifera, Cnidaria, Ctenophora, Platyhelminths, Orthoconnectidæ, Dicyemidæ, Nemertina, Nemathelminthes, Acanthocephali, Rotatoria, Annelida (including Echiurids and Leeches herein), Sipunculidæ, Chætognatha, Enteropneusta, Echinoderma, and the Arthropoda. The various classes of the last-named phylum occupy two-thirds of the work at present issued. There remain still to be dealt with the Mollusca, the Bryozoa, and the Tunicata.

The best idea which can be given of the scope and value of this work is obtained when we compare it with Frank Balfour's treatise on comparative embryology. It is not too much to say that it is the most valuable text-book for the zoological student which has appeared since Balfour's book, and is a worthy successor to it. The mass of literature, vast as it was ten years ago, has increased enormously in the interval. Drs. Korschelt and Heider have carefully gone over it all; and not only that, but they accurately and clearly give each author's contribution to the subject in hand, citing authority for every statement made, so that the student can go to the original treatises for fuller detail. I do not know of any scientific treatise which shows so clearly the authors' desire to do justice to every fellow-worker of whatever nationality, and to produce a work which shall be a complete and trustworthy guide to the recent literature of a prodigiously prolific subject. Very often the authors abstain from offering a decided opinion upon a matter where the observations made have led previous writers to diverse conclusions: such cases are those in which the facts are incompletely observed and obviously require renewed investigation. But where the observed facts on one side or the other are of a decisive character, the authors, after giving both sides in detail, exercise a judicial function.

The book deals not only with the earlier but also with the later stages of development, and not merely with the facts of embryology, but with the conclusions as to the affinities of groups, which are so severely tested by the progress of embryological inquiry.

It is not possible to particularize in regard to such a work as this, but I have been struck by the very full way in which the morphology of the Crustacea, and each succeeding class of Arthropods, has been dealt with in every respect in which embryology throws light upon it. A very fully illustrated chapter gives a complete and impartial account of the researches of Sedgwick, Sheldon, and Kennell on the development of different species of Peripatus. The question as to the relationship of the Arachnida to Limulus and the Eurypterines, alluded to above, is fully treated by Drs. Korschelt and Heider. They summarize the arguments with clearness, and state and

weigh fairly nearly every fact which has been adduced in favour of the association of Limulus and the Eurypterines with the Arachnida. Their conclusion is as widely different from Lang's as is their method of discussion.

There can be no doubt that we have in this new treatise on comparative embryology one of those invaluable, indispensable works for the production of which authors receive the gratitude and esteem of their fellow-workers in all lands. It is a truly first-rate book.

E. RAY LANKESTER.

#### MODERN ARTILLERY.

*The Artillery of the Future and the New Powders.* By James Atkinson Longridge, M.I.C.E. (London: E. and F. N. Spon, 1891.)

MR. LONGRIDGE keeps pegging away at his favourite subject, which he originally brought forward, now more than thirty years ago, in the Proceedings of the Institution of Civil Engineers.

His valuable ideas are at length receiving recognition, and his principle of strengthening guns, by layers of wire wound with appropriate initial tension, is now largely employed in the construction of modern ordnance.

The chief object of the present book is to point out that the fullest application of his principle of wire strengthening permits of the use of much higher powder pressures than are considered admissible in Government circles; and that thereby guns may be much shortened and reduced in weight, while at the same time the full power of the most modern high explosives can be utilized.

This is to a great extent a return on the steps which have guided our gun designers in recent years; their chief object being, to reduce initial pressure as much as possible, say down to 17 tons per square inch, and to get the full power out of the powder by a great increase in the length of bore, up to 40 and even 50 calibres in length in guns of large size.

Mr. Longridge is fully acquainted with all the valuable and original work in gunnery science which has been developed of late years in France by Sarrau, Veille, and Seberty; and analyzes carefully in chapters ii. and iii. the various experimental methods and empirical formulas in use for the measurement of powder pressure in the bore of a gun.

In chapter iii. he attempts a theoretical explanation and formula for maximum pressure and total energy, but his investigation rests upon an assumption of the *adiabatic law*; and the mathematical treatment is not presented in an inviting or elegant form. Considering the unexplained chemical combinations which affect the rate of combustion of the modern smokeless powders, this mathematical assumption can only roughly account for an average performance, and leaves unexplained the violent abnormal effects sometimes experienced and shown in General Wardell's curves, to guard against which the gunmaker has to exercise a vigilant caution.

General Brackenbury is quoted as calling gunpowder the Spirit of Artillery, and in his official capacity, Superintendent of the Royal Gunpowder Factory, as a maker of gunpowder, saying metaphorically, "How sad the body is so weak" in preference to "What a pity the spirit is so strong."

But so long as steel is the strongest material of which the body—the gun—can be constructed, makers of powder and explosives, new and old, must be content to moderate and regulate the strength of their compounds. Much was expected of gun-cotton in its early days as a propulsive agent, but these hopes were falsified by the uncertainty of its action.

Again, with the vast extent of our Empire, climatic conditions have to be considered in their bearing on the action and preservation of explosives, conditions which do not affect French or German artillerists, who know the exact limits over which their warlike operations must take place.

A. G. G.

#### GIANTS AND ACROMEGALY.

*The Skeleton of the Irish Giant, Cornelius Magrath.*

By Dr. D. J. Cunningham, F.R.S. (Dublin: Published by the Royal Irish Academy, 1891).

NOTWITHSTANDING the close attention which has been applied to the clinical aspects of disease during so many centuries, every now and then some observer, more acute than his brethren, recognizes a morbid condition which had not previously been satisfactorily discriminated, and gives to it a name. Although in some cases the form of disease is thought to be new, and is described as such, it is generally found, when the records of medicine are examined, that corresponding cases and symptoms had been noticed previously, although their import had not been properly understood, and they had not been distinguished by a special name.

Amongst the latest contributions in this direction is a memoir published in 1886 by M. Pierre Marie, in which he described a morbid condition where the hands and feet were enlarged out of proportion to the rest of the body, chiefly due to a hypertrophy of the soft parts; and where the face had become remarkably elongated and deformed, partly from hypertrophy of the soft parts, but more especially from an increase in magnitude of the bones of the face, of the glabella and supraciliary ridges of the frontal bone, and of the pituitary fossa. To this condition M. Marie gave the name of Acromegaly. The attention of physicians and pathologists having thus been directed to the subject, several similar cases were described in the course of the next three or four years; and a few other cases and specimens previously recorded in medical literature were recognized as having been similarly affected. One of the most important of these was a skeleton in the Anatomical Museum of the University of Edinburgh, which was determined by Dr. H. Alexis Thomson to be a case of acromegaly, and the giant characters of the skeleton were associated with the peculiarly hypertrophied condition of the soft parts above referred to.

It was the perusal of Dr. Thomson's account of the Edinburgh skeleton which led Prof. Cunningham to pay especial attention to the characters displayed by the skeleton of the Irish giant Cornelius Magrath, which has been in the museum of Trinity College, Dublin, for 131 years, and to conclude that it also was an example of acromegaly. Dr. Cunningham's memoir, in addition to the anatomi-

cal description of the skeleton, contains much interesting information relative to Magrath himself, which he has collected from various quarters. Magrath was born in Tipperary in 1736, and died in Dublin in 1760, at the age of 23. He seems to have attained a height of 6 feet 8 $\frac{3}{4}$  inches when he was only sixteen years old; and for several years he travelled about as a show, and visited many of the great cities of Europe. The accounts which were given of his height in the periodical literature of the day, after he had reached his full dimensions, varied considerably; and a most exaggerated statement, that he was 8 feet 4 inches, made apparently with the view of out-rivalling the altitude of the skeleton of another Irish giant, Charles Byrne, in the Hunterian Museum, London, has found its way into anatomical literature. Dr. Cunningham has subjected all these statements to a careful analysis, and has studied and examined the skeleton itself, from which he concludes that the articulated skeleton is only 7 feet 2 $\frac{1}{2}$  inches high, and that this in all probability expresses the maximum height during life. Magrath is thus by no means the tallest giant whose height has been put on record. Charles Byrne was three or four inches taller; and Topinard, Ranke and Virchow have recorded examples of persons who ranged in height from 7 feet 3 $\frac{3}{8}$  inches to 8 feet 4 $\frac{1}{2}$  inches. From an examination which Prof. Cunningham has made of the skeleton of Byrne in the Hunterian Museum, he has come to the conclusion that in certain particulars, *eg.* the magnitude of the lower jaw, the dilated pituitary fossa, and the great size of the feet, it presents some of the characters of acromegaly. It must not, however, be supposed that giant growth is necessarily associated with the condition of acromegaly; for although it is not unusual to find the lower jaw disproportionately large in giants, yet it by no means follows that the other signs of acromegaly should be present.

Dr. Cunningham suggests that the morbid condition which M. Marie christened acromegaly should be known by the more etymologically correct term of "megalacria."

#### PEAKS AND PASSES IN NEW ZEALAND.

*With Axe and Rope in the New Zealand Alps.* By George Edward Manning. With Illustrations. (London: Longmans, Green, and Co., 1891.)

TEN years ago the ice scenery of the New Zealand Alps was almost unknown even to the colonists. But in 1882 the Rev. W. S. Green, with two first-class Swiss guides, explored the glacier region beneath the highest peak—Aorangi, or Mount Cook—and arrived, after a long, difficult, and dangerous climb, on the summit of that mountain. His delightful volume "The High Alps of New Zealand," and the laborious explorations of Dr. von Lendenfeld in the following year, indicated that a region, certainly not inferior in grandeur and beauty to the Alps of Europe, could be reached in a journey of little more than two days from Christchurch. Since then the "Britain of the South" has become proud of possessing the "playground of Australasia"; the number of visitors has been rapidly increasing; an hotel has been built in a convenient situation near the foot of one of the glaciers; surveys have been undertaken; and the author of this volume, with one or two friends—inexperienced in mountain craft

but inured to rough work in a wild country—commenced, in 1886, a series of expeditions in the “High Alps” of the Antipodes.

The Southern Alps proper, for over one hundred miles, form the backbone of the South Island, running roughly from north-east to south-west, the crest of the chain lying much nearer to the western than to the eastern coast. In the neighbourhood of Aorangi the former is about twenty miles away, while the distance of the other is quite five times as much. Thus the valleys fall more rapidly towards the west than towards the east, on which side also a wide tract of plain separates the sea from the foot of the hills. But in one respect, the New Zealand Alps, at any rate on their eastern flank, differ from their European namesakes, for they are pierced more deeply by the lowlands. Even at the foot of Aorangi, in the vicinity of which almost all the highest peaks are situated, the comparatively level floor of the Tasman valley is rather less than 2500 feet above the sea. Thus, although the New Zealand peaks are considerably lower than those of the European Alps—for few of them surpass 10,000 feet, and the highest summit of Aorangi is only 12,349 feet—they tower as high and as steep above their actual bases as the Oberland giants above the valley of the Lutschine. As Mr. Mannering says, Aorangi rises “for nearly 10,000 feet from the Hooker glacier, and Mount Sefton 8500 feet from the Mueller glacier, whilst the western precipices of Mount Tasman (11,475 feet) are stupendous.” These words indicate another peculiarity of the New Zealand Alps. Here the snow-line lies very much lower than in Switzerland; in this central district it is only about 5000 feet above the sea. Thus the glaciers are actually greater, and descend much below those of Switzerland. The Tasman glacier, which may be compared with the Gross Aletsch of that country, is from 18 to 20 miles long, and terminates at a height of 2456 feet above the sea. On the western side the ice approaches occasionally to within 600 feet. Thus in the New Zealand Alps the Alpine climber meets with the same difficulties, and is rewarded by the same class of scenery, as he finds in the Old World amid peaks and passes three thousand feet higher. For instance, the Hochstetter Dome, first ascended by Dr. von Lendenfeld, though only 9315 feet above the sea, and presenting no special difficulties, is a very long and laborious excursion over ice and snow. Mr. Mannering and his two companions found it “twelve hours’ hard going” from their camp—von Lendenfeld’s party were out more than double the time.

But great as are these glaciers, they are, like those in our own hemisphere, attenuated representatives of their predecessors—for New Zealand also has had its Ice age. Once they extended far away into the lowlands. There, erratics and ice-worn rocks abound for miles. Lakes Tekapo and Pukaki are dammed by moraines, and in the valley of the Tasman River some singular terraces can be traced for 40 miles from the point where they commence, near the end of the glacier, at a height of some 2000 feet above the valley. Much *débris* is still transported by the glaciers of the eastern side of the chain, but those on the western are cleaner. The main range consists of stratified rocks, which disintegrate, as the climber soon discovers to his sorrow, rather readily; and Mr. Mannering attributes the difference in the amount of *débris* to the fact that the

beds have a westerly dip. This, at any rate, accounts for the precipitous character of the eastern face of the mountains. We infer, also, that denudation has been more rapid on this side, for Aorangi projects in advance of the watershed, like the Viso and other peaks on the Italian side of the Alps.

The ascent of Aorangi is evidently a long, difficult, and even dangerous excursion. The route is quite as circuitous as that formerly followed in the ascent of the Bernina; for the great ice-fall of the Hochstetter glacier, 4000 feet high, has to be turned, and another glacier basin crossed, before beginning the steep ascent of the actual peak. Mr. Green’s party was forced to turn back without actually touching the culminating point, though they had overcome all difficulties, for the short half-hour which the completion of the excursion would have required might have made return impossible. As it was, they were benighted among the glaciers. Mr. Mannering and his friend, after five attempts, reached a point about 100 feet below where Mr. Green halted, was compelled to turn back for the same reason, and had a dangerous descent over the snow-fields in the darkness. But as an Alpine Club was founded a few months since in New Zealand, there will probably not be many peaks to climb or passes to discover when another decade has passed.

Mountaineering in New Zealand is not for climbers fond of luxury. Guides and porters are at present unknown. Mr. Mannering and his companions had to carry their own “swag”—and heavy loads these were—cut their own steps, do everything and discover everything for themselves, for they were self-taught mountaineers. Sometimes he had only one companion, and then the labour and the danger were alike increased. The weather also seems to be more unsettled than it is in the Alps. The rainfall is heavy—150 inches in some places. Thus fresh snow often adds to the difficulties and the dangers of excursions, and falls of stones seem common, as might be expected. Mr. Mannering tells most pleasantly and unaffectedly a story of pluck, endurance, and skill, of which our kinsmen in New Zealand may be justly proud. He is a careful observer of Nature, and a true lover of mountain scenery, as well as a daring climber. His book contains a number of illustrations, taken from photographs, which show that the peak and glacier scenery of the Aorangi group is worthy of the author’s enthusiastic praise; and it is not only very pleasant reading, but also adds much to our knowledge of the region. It may be added that, if the traveller is not satisfied with the perils of rocks and snow, those of flooded rivers are a common experience; and Mr. Mannering, in his final chapter, describes the doubtful pleasures of a canoe voyage down the Waitaki River.

T. G. BONNEY.

#### OUR BOOK SHELF.

*Manual of the Science of Religion.* By P. D. Chantpie de la Saussaye. Translated by Beatrice S. Colyer Fergusson. (London: Longmans, 1891.)

THOUGH the title of this volume seems to imply that it is a complete thing, it is really only the first half of Prof. de la Saussaye’s book. Nearly three-fourths of the Amsterdam Professor’s manual is devoted to a sketch of the chief ethnic religions and of Islam; whereas the English

book, corresponding as it does to the first of the two German volumes, omits the ancient religions of Persia, Greece, Rome, and Germany, as well as Mohammedanism. Without these we have nothing that can fairly be called by the name borne on the title of the translation; and the omission of Persia in particular makes the book most tantalizingly imperfect as regards a single connected group of faiths. It is not fair either to the author or to his readers to give a part of the work as if it were a whole, and to set it forth to the world without even putting "vol. i." on the title-page.

The work of translation has been performed with care, and generally, so far as we have been able to test it, with accuracy. But the book is rather heavy reading, as translations from the German are apt to be, when the translator has not realized that the difference between the idioms of England and Germany is so great that a successful version must recast whole sentences instead of aiming at a literal reproduction of words and clauses.

As regards the substance of the book, the reception which it has obtained, in its German form, is a sufficient proof that Prof. de la Saussaye has met a felt want in the literature of his subject. A book that covers so wide a field cannot be without errors in detail. No man can know at first hand all the ancient literatures that are dealt with; nor can it be supposed that, on matters where specialists are often at variance, one who is not a specialist can always hit the mark. The general principles of the science of religion are not yet worked out with sufficient clearness to give the student of religions in general sure points of view for the criticism of the divergent results that have been reached by students of special religious literatures. Perhaps to say this is to say by implication that a general manual of the subject is an undertaking for which the time is not yet ripe; and certainly the science of religion (as distinct from the scientific study of individual religions in their historical development) is still in a very elementary stage. But Prof. de la Saussaye is no dogmatist; he frankly admits the obscurity in which many fundamental problems are still involved, and he writes throughout with great impartiality and moderation, as well as with extensive knowledge of recent researches. His book will be very useful to all who wish to know the present state of inquiry, and do not forget that many things in his exposition are to be taken as still doubtful, even where the author himself does not expressly accompany them with notes of uncertainty.

W. R. S.

*Euclid's Elements of Geometry.* Book XI. By A. E. Layng, M.A. (London: Blackie and Son, Limited, 1891.)

OF all Euclid's books, the eleventh is one that forms a stumbling-block to the beginner in solid geometry. Not that the proofs in themselves are of a difficult nature, but simply that the figures have to be drawn perspective to illustrate the various planes, and the student finds it hard to bring himself to believe the equality of angles and lines which appear to him to be unequal.

The author of this book, like one or two others before him, by varying the thickness of the lines used in construction, simplifies matters very considerably, for by this means the eye can distinguish directly the different planes. Of the propositions themselves, little need be said, unless we mention the use throughout of all the well-known symbols: the occasional interpolated worked-out examples, and the notes and exercises, although not in any great quantity, will be found very useful. In the collection of miscellaneous examples, theorems relating to tetrahedrons, pyramids, spheres, &c., are included. Preceding the series of examination-papers, which are here arranged in a progressive order of difficulty, and taken from papers set lately, are two appendices, the first deal-

ing with transversals, harmonic section, and pole and polars, the second with a few alternate proofs of propositions. The manner in which most of the proofs are worked out is both neat and brief, and the definitions are all clearly stated and illustrated. We may add that, although the work is not the best of its kind we have seen, yet it has many good points which recommend it to the student of geometry. W.

*Illustrations of the Flora of Japan, to serve as an Atlas to the Nippon-Shokubutsushi.* By Tomitarō Makino. (Tōkyō, Japan: Keigyōsha 1, Urazimbōchō, 1891.)

THIS is a monthly publication, containing excellent uncoloured figures of plants, with analyses of their floral structure, fruit, and seed, and descriptions in English as well as in Japanese. The drawing and lithography, by Mr. Makino himself, are quite equal to the average work in this country—indeed, one might say above the average; the lithography being light and effective, with few lines in it. Moreover, the English descriptions are intelligible, correct, and idiomatic, and not too long, nor superfluous. Botanically and horticulturally this production of the Far East will be welcome, and even indispensable, in the West, as many new species are described. Already nine parts have appeared, with illustrations of fifty-seven species belonging to various natural orders. No system of classification is followed; whatever is of interest or novel being taken as it presents itself.

W. B. H.

*About Ceylon and Borneo.* By Walter J. Clutterbuck, F.R.G.S. (London: Longmans, Green, and Co., 1891.)

IN this volume Mr. Clutterbuck gives some account of Ceylon as he saw it during a recent visit, and as it was fourteen years ago, when he resided for a short time in the island. He then describes what he saw in the course of a visit to Brunei and British North Borneo. Readers who like books of travel will find a good deal to interest them in the author's impressions, which are recorded in a lively style.

#### LETTERS TO THE EDITOR.

[The Editor does not hold himself responsible for opinions expressed by his correspondents. Neither can he undertake to return, or to correspond with the writers of, rejected manuscripts intended for this or any other part of NATURE. No notice is taken of anonymous communications.]

#### Wind Direction.

A SHORT time ago there was some correspondence in your columns on the relations of north-east and south-west winds in recent years; Mr. Prince, of Crowborough, having observed at that place that while, as a rule, the south-west winds were in excess of the north-east, the reverse had occurred in each of the five years 1885 to 1889. The Greenwich records were examined by Mr. Ellis with regard to this point, but he found them at variance with those of Crowborough, the south-west winds having continued in excess of the north-east throughout those five years.

By combining several directions, the Greenwich figures, as tabulated by Mr. Ellis in his paper to the Royal Meteorological Society (Quart. Journ., October 1890, p. 222), will be found to reveal some curious relations, which seem to invite attention. I have added together the figures (numbers of days) for north-east, east, and south-east winds on the one hand, and those for north-west, west, and south-west on the other; then smoothed each set of sums by means of five-year averages. The results are shown in the two curves of the accompanying diagram. The continuous curve (a) represents north-east, east, and south-east winds (and its vertical scale is at the left). The dotted line curve (b) represents north-west, west, and south-west winds (and

its vertical scale is at the right). It will be understood that each year-point of those curves represents an average of five years.

It would appear that easterly winds (north-east, east, and south-east) at Greenwich have been increasing in prevalence, on the whole, since about 1865; the five years' average for that year is 83·8, and this grows to 111·4 in 1886 (about one-third). On the other hand, westerly winds (north-west, west, and south-west) have diminished, on the whole, since 1861; the five years' average for that year is 210·8, and this diminishes to 159·0 in 1887 (about one-fourth).

Judging by the past, we might perhaps consider that we must be near a decided turn of the curves; possibly past it in the case of easterly winds; in which case we should look for more westerly and less easterly wind in the near future.

(a) 1865 min.						Average.
1863	...	1864	...	1865	...	1867
77	...	104	...	76	...	90
						83·8

(b) 1861 max.						Average.
1859	...	1860	...	1861	...	1863
199	...	215	...	203	...	226
						210·8

(b) 1887 low point.						Average.
1885	...	1886	...	1887	...	1889
157	...	158	...	155	...	161
						159·0

A. B. M

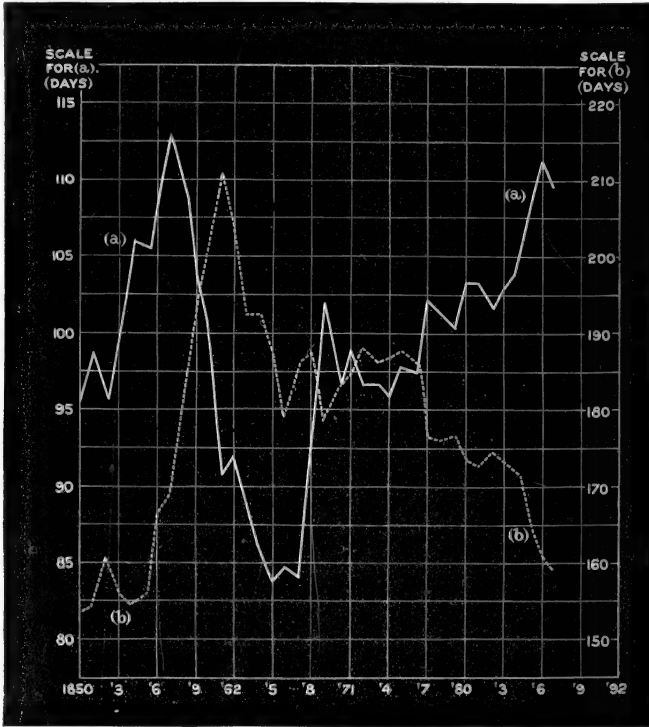

(a) = North-east, east, and south-east wind (Greenwich). (b) = North-west, west, and south-west wind (Greenwich). Actual figures smoothed by means of five-year averages.

From the "crest" of (a) in 1857 to the last point is thirty years. Are those long variations possibly a manifestation of the thirty-five years' period of Brueckner?

These curves might have begun at an earlier date, for the figures commence in 1841. But in the earlier years, and apparently to about 1855, a larger proportion of days seem to have been reckoned as "calms" than afterwards (owing to a difference of rule), so that the curves to about 1855 are not exactly comparable with the remaining portions.

I append a few figures, showing the derivation of maximum and minimum (or low point) averages:—

(a) 1857 max.						Average.
1855	...	1856	...	1857	...	1859
114	...	111	...	113	...	99
						112·6

The Migration of the Lemming.

MY attention having recently been drawn to the question of the migration of that little Norwegian rodent the lemming, as a serious obstacle to the theory of natural selection, and hence to evolution generally, I write to call attention to what appears to me to be a possible factor in the starting of the migration.

It is that when the lemmings become too numerous for the means of subsistence upon the inland plateaux, which may be described as their home, the "fittest" lemmings, by battle, turn out from the district all those of their weaker brethren who are unable to withstand the contest.

The unfittest being thus driven out from their home, are forced to migrate somewhere. Why they move incessantly to the westward seems a problem yet to be satisfactorily solved.



My reason for suggesting such an origin for the migration is that it takes place every three or four years from the same plateau. It is very evident, therefore, that—abiogenesis being now out of court—some lemmings must be left there to continue the species. Now, it is not likely that the weakest are left behind, otherwise their survival year after year would be quite problematical. Do not the facts point unquestionably to the strongest being left to continue the race?

To the criticism that there is no evidence of fighting having taken place amongst the migrants, my reply would be that no one, so far as I can learn, has seen a migration start, or seen one immediately after it has started—the only time, that is, when the effects of such fighting would be apparent, for after a few days those seriously injured would have died and have been left behind, while those only slightly injured would have recovered sufficiently to be indistinguishable from the remainder.

Churchfield, Edgbaston. F. HOWARD COLLINS.

### The New Railway from Upminster to Romford, Essex.

ON the above railway, now being constructed, there is a section of unusual interest a few yards north-east of the church at Hornchurch, showing the Chalky Boulder Clay (15 feet seen) under sand and gravel belonging to the highest terrace of the Thames Valley, and resting on London Clay. Hitherto, Boulder Clay has not been seen in this district in connection with Thames Valley deposits, its most southerly exposures lying about three miles northward, on London Clay or Bagshot Beds.

I have been carefully watching this cutting for some time, with a view of sending an account of it to the Geological Society when it shall have been completely excavated. But, though much has still to be done, the half of it finished has already been sloped, and the arrangement of the beds—clear a month ago—greatly obscured. It has therefore been suggested to me that a few lines on the subject in NATURE may be the means of enabling geologists interested to visit this section while the Boulder Clay is still clearly visible in some portion of the cutting.

It may be useful to add that the distance from Hornchurch Station is about a mile, and that the visitor, after leaving the church on his right hand, should take the first road on his left.

T. V. HOLMES.

28 Croom's Hill, Greenwich Park, S.E.,  
December 7.

### Peculiar Eyes.

THE inability of keeping one eye shut and the other open at the same time, is a fact well known to drill-sergeants. I well remember, when a conscript some sixteen years ago, how a great number of recruits were unable, even after repeated efforts, to do so; but I had no difficulty about it. At that time, too, my eyes were about equal in power; but at present while the right eye is of normal power, the left eye presents a much less distinct image. I can only ascribe this to the habit of working at the microscope with the right eye without closing the left. It is especially at this work that the defective sight in the latter is noticeable. I do not think my ten months of rifle practice has anything to do with it, except, perhaps, in emphasizing the tendency to use the right eye, the image of which is now so predominant, that in covering a bull's eye, for instance, it is immaterial whether the left eye be closed or not.

G. K. GUDE.

5 Giesbach Road, Upper Holloway, December 7.

### Grafted Plants.

REFERRING to Prof. Henslow's paper on "A Theory of Heredity based on Forces" (November 26, p. 93), the behaviour of grafted plants seems to require, for its explanation, the possession by both stocks and graft of something analogous to a distinct individuality, call it what we may. It is difficult enough to understand, especially in the case of nearly-related forms, why the stock generally has no, or so little, influence on the graft; but, assuming the absence of individuality, the difficulty is largely increased. The graft takes its nourishment through the stock, and yet retains its characteristics unimpaired. I argue from this that not only does the graft possess an individuality of its own, but that this is so marked that it can take its nourishment direct from the stock, while at the same time straining out,

as it were, whatever it is that constitutes the individuality of the stock. The phenomena presented by parasitic plants seem to bear out this view.

W. H. BEEBY.

### Intelligence in Birds.

A FEW weeks ago I received a specimen of *Podoces panneri*, the typical desert bird of Central Asia, which had been kept for some months in captivity at Perovsk. The first thing the creature began to do, when located by me in a spacious *volière*, was to pick some food (cooked rice with baked egg), and to bury it in the very thick sand layer with which the floor of the cage was provided. This was the incessant occupation of the bird on the first day of its instalment. But the task was almost completely abandoned from the next day; the bird, evidently remembering the conditions of its former life in captivity, found it useless to make provision for the future when a fresh supply of food daily appeared.

The fact referred to seems to indicate, first, that the birds in question are in the habit of making provision in the wild state, the powerful and slightly curved bill being admirably adapted for the purpose of making holes, even in a hard ground. It shows, also, how abruptly the habits of animals can be modified when the conditions of their environment are changed.

Now, a question naturally arises, How must we regard this habit of burying food—as the result of a long inheritance, or as an effect of constant imitation of older birds by younger ones?

A. WILKINS.

Tashkend, Central Asia, November 8/20.

### SIR ANDREW CROMBIE RAMSAY.

THOUGH this illustrious geologist has been laid aside by growing infirmity for the last ten years, the news of his death will carry regret into the hearts of many men of science, not in this country only but all over the world. Born in Glasgow, and intended for a mercantile profession there, he spent some few years in business; but, partly on account of delicate health, betook himself for rest and open-air exercise to the island of Arran. One of the friends of his early years, Prof. Nichol, of Glasgow University, the well-known writer on astronomical subjects, had much influence in directing his studies into a scientific channel, so that the marvellous geological lessons to be learnt from the rocks of Arran soon arrested Ramsay's attention. Throwing himself with all the ardour of an enthusiastic nature into the pursuit which he now took up, he was led to climb the mountains and traverse the glens throughout the length and breadth of Arran. In this way, face to face with the facts of Nature, and amid some of the most charming scenery of his native country, he taught himself the rudiments of geology, and acquired that clearness of insight for geological structure, that love of mountain-forms, and that freshness and originality of interpretation, which marked him out from his associates in later years. But above all, by actually mapping the grouping of the rocks, he gained that precision in field-work which was to bear such notable fruit in his connection with the Geological Survey. He constructed a geological model of Arran on the scale of two inches to a mile, and made copious notes of the geological structure of all parts of the island.

The meeting of the British Association in Glasgow in the year 1840 proved to be the turning-point in his career. The model and map of Arran which he had made were exhibited at the Geological Society, and he gave a brief account of them and of the geology of the island. Among the geologists who listened to him was Murchison, who, struck with his ability and his devotion to the science, offered to take him on an expedition which the author of the "Silurian System" had then projected to America. Ramsay accordingly went up to London, but found that the voyage across the Atlantic had been abandoned for a journey into Russia, and that he was not to take part in it. Murchison, however, spoke so warmly in favour of his

young friend to Sir Henry De la Beche, the Director-General of the Geological Survey, that a post was at once found for him on the staff of the Survey, and before many days Ramsay was at work at Tenby. He joined the service in the spring of 1841, immediately after the publication of the little volume on Arran, which embodied the fruits of his labours in previous years. From that time onward his life was spent continuously in the work of the Survey until he retired at the end of 1881. So capable a lieutenant did he prove himself to the chief of the staff, that after only four years he was appointed Local Director for Great Britain.

From the first Ramsay showed that, with habits of patient observation and cautious induction, he combined a faculty for bold and broad generalization. His remarkable paper on the denudation of South Wales, published in 1846, was one of the earliest essays in which the amount and effects of denudation were worked out from detailed surveys of the geological structure of the ground. He then struck the key-note which may be heard through nearly all his subsequent contributions to scientific literature. He was one of the earliest observers to realize that the existing topography of the land has a long and interesting history, much of which may still be deciphered by the use of geological investigation.

The name of A. C. Ramsay will ever be honourably associated with the story of the gradual working out of the records of the Ice Age. Following up the results obtained by Agassiz, Buckland, Darwin, and others in this country, he threw himself with all his ardour into the study of the glaciation of Wales, tracing the limits of the glaciers of that region, and extending his experience by frequent excursions among the Swiss Alps. His scattered papers in scientific journals undoubtedly did much to stimulate general interest in the history of the Glacial Period, and to create a special and voluminous literature of this subject. His views differed much from those of some of the older geologists of the day, and led to some active controversy. Especially did opposition arise when, after studying long and carefully the erosive action of land-ice, he came to the conclusion that certain lake-basins in various parts of the world had been scooped out by ice. Murchison, Lyell, and others of less fame, entered the lists against him; but he had a considerable following among the younger geologists. And this controversy still fitfully continues.

In connection with his glacial work, mention should be made of his bold endeavour to prove that ice-action had been in operation more than once in the geological past. His paper on the Permian breccias of England called attention to the evidence of transport of fragments of rock from Wales, and to the resemblance between these fragments and those in glacial moraines and boulder-clay. He subsequently detected what he thought to be similar traces of ice-carried materials in the Old Red Sandstone; and in one of the last papers which he wrote he gathered together the various pieces of evidence in favour of a long succession of Glacial periods in the geological past.

Two of the most suggestive essays he ever wrote were his well-known Presidential Addresses to the Geological Society in 1863 and 1864, in which he worked out, from his wide practical acquaintance with the stratified formations of Britain, the idea of breaks in the succession of organic remains in the geological record. To the geologist and the palæontologist these papers marked a distinct epoch in the advance of geological inquiry; while to the biologist concerned with the history of the evolution of organized existence on this planet they were full of luminous thought.

By far the largest part of Sir Andrew's contributions to geological literature is to be found in the maps, sections, and memoirs of the Geological Survey. The mapping of the volcanic districts of North Wales, in which he took

the leading part, will ever remain the best monument of his skill as a field-geologist. His exhaustive memoir on that region has long since taken its place as one of the standard works of reference in our geological literature.

In his later years he seems to have taken pleasure in reverting to some of the inquiries which he started in an early part of his career. He returned with renewed zest to the study of the history of topographical features, discussed as to how Anglesey became an island, and traced out the story of the River Dee. In successive editions of the work on the "Physical Geography and Geology of Great Britain," which at first was given as six lectures to an audience of working men, he worked out in greater fulness the chief stages through which the surface of this country seemed to him to have passed before it acquired its present features.

Of the value of his scientific labours full recognition was made by his contemporaries. He was elected President of the Geological Society in 1862, President of the Geological Section of the British Association in 1866 and again in 1881, and President of the Association itself in 1880, when the meeting was held at Swansea. He received the Wollaston Medal of the Geological Society, the Neill Medal of the Royal Society of Edinburgh, and a Royal Medal from the Royal Society. He was chosen into the honorary list of many learned Societies at home and abroad. On the death of Sir Roderick Murchison in 1871, he was appointed Director-General of the Geological Survey. At the end of 1881 he resigned this office, was knighted for his distinguished services, and soon thereafter went to reside at Beaumaris, where his strength has gradually given way, until he died on the evening of the 9th inst.

There was in Sir Andrew Ramsay such simplicity and frankness that men of the most diverse natures were attracted to him, and as they came to know him more intimately the gaiety and kind-heartedness of his disposition attached them to him in the closest friendship. Fond of literature, and glad to relieve the pressure of his scientific work by excursions into the literary field, he had acquired a range of knowledge and of taste which gave a special interest to his conversation. Now and then he found time to write an article for the *Saturday Review* in which this literary side of his nature would find scope for its exercise. But the daily grind of the official treadmill left him all too little time for such diversions. His death removes from our midst one of the foremost geologists of our day, and from the friends who knew him in his prime, a large-hearted, lovable man, whose memory they will cherish till they too pass away.

A. G.

ON VAN DER WAALS'S ISOTHERMAL EQUATION.

ONE of the objections raised against this equation by Prof. Tait in *NATURE*, vol. xlv. pp. 546 and 627, brings clearly to light the importance of the question whether the finite size of the particles should be accounted for by an equation of the form—

$$p_1(v - b) = \frac{1}{2} \sum mu^2, \dots \dots \dots (1)$$

where  $p_1$  represents the internal pressure, equal to the sum of the external pressure  $p$ , and the molecular pressure  $a/v^2$ , and  $b$  some multiple of the total volume  $b_1$  of the particles; or if this equation must rather have the form—

$$p_1 v = \frac{1}{2} \sum mu^2 \left( 1 + \frac{b}{v} \right), \dots \dots \dots (2)$$

<sup>1</sup> Prof. Korteweg's paper and accompanying letter are of date November 4, but owing to an accidental delay they did not reach me until after the appearance of my last communication (*NATURE*, November 26, p. 80). Otherwise I should, of course, have made reference to them. It will be seen that Prof. Korteweg draws attention to the form of the virial equation applicable in one dimension. RAYLEIGH.

December 2.

In the first case, in substituting  $\rho + a/v^2$  for  $\rho_1$ , and  $R(1 + a)$  for  $\frac{1}{2}\Sigma mu^2$ , the well-known formula of Prof. Van der Waals is arrived at. In the second case, the same substitution leads to a quite worthless formula, unfit to explain even qualitatively the conduct of gases under compression.

The first form is the one which presents itself most naturally when, as was done by Van der Waals, the extension of the molecules is considered as a diminution of the volume in which they are moving; the second is obtained as a first approximation, when the virial equation is extended to the repulsive forces which come into play at the collisions. Of course, both methods, if they could be worked out with absolute rigour, would give the same result; but, this being impossible for both of them, the question as to which gives the better approximation is not at all an unreal one.

Now, it is extremely improbable that this question should have to be answered in a different way for linear and for three-dimensional space; yet for linear space the first method leads to a quite easy and absolutely rigorous solution, and the equation thus obtained is analogous to the first form.

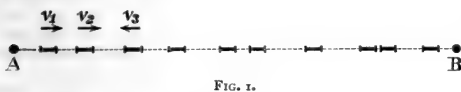

In order to prove this, let A B (Fig. 1) represent a linear space of length  $l$ , bounded by two rigid walls, A and B, and let there be moving in this space some perfectly elastic particles, all of the same mass,  $m$ , and length,  $\lambda$ , but having different velocities,  $v_1, v_2, \dots, v_n$ . At every encounter of these particles there will be simply an exchange between their velocities; therefore at every moment one of the particles will have the velocity  $v_1$ . On this particle we fix our attention, following it on its way till the next collision. After this collision we leave it to its fate, directing our attention to the other particle, which has now acquired the velocity  $v_1$ . Proceeding in this manner, it is obvious that at every collision a distance  $\lambda$  is economized, which has not to be travelled over by the centres of the molecules. Starting, then, from the wall A and passing over to the wall B and back again, the number of collisions is  $2(n - 1)$ , and the distance economized  $2n\lambda$ , (adding  $2\lambda$  for the collisions against the walls). The distance travelled over by the centres consequently being  $2l - 2n\lambda$ , it is clear that the number of collisions with velocity  $v_1$  against one of the walls amounts to  $\frac{v_1}{2(l - n\lambda)}$  in one unit of time, and the corresponding change of momentum to  $\frac{mv_1^2}{L - n\lambda}$ , so that the pressure on the wall is measured by

$$\rho = \frac{\Sigma mv^2}{L - n\lambda} \dots \dots \dots (3)$$

Of course, for space of two and three dimensions, the problem is much more complicated. Yet in 1877 I gave a solution<sup>1</sup> of it for spherical particles which, according to my opinion, is rigorous so far as the several encounters between the molecules may be looked at as independent of one another. For a short time after each collision the possibilities of fresh collisions are considerably influenced by the proximity of the departing molecule. This influence, certainly of very difficult mathematical treatment, is disregarded in my calculations.

The outcome of these calculations<sup>2</sup> is that of every

<sup>1</sup> *Verslagen en Mededeelingen der Kon. Ak. v. Amsterdam*, 20 Reeks, Deel x; *Archives Néerlandaises*, t. xii.

<sup>2</sup> I am bound to acknowledge that the same correction, which is indicated further on for Lorentz's calculations, has to be applied to the number of collisions given in my paper.

unit of distance only the  $(1 - 4b_1/v)$ th part has to be travelled over by the centres of the molecules, the  $4b_1/v$ th part being economized at the collisions. Therefore the number of the encounters with the bounding walls is augmented in the proportion  $1 : 1 - 4b_1/v$ , and the formula  $\rho v = \frac{1}{2}\Sigma mu^2$  is to be changed to

$$\rho(v - 4b_1) = \frac{1}{2}\Sigma mu^2 \dots \dots \dots (4)$$

In 1881, my friend H. A. Lorentz applied the virial equation to the calculation of the influence of the size of the particles on the pressure. In this manner he obtained the formula—

$$\rho v = \frac{1}{2}\Sigma mu^2 \cdot \left(1 + \frac{4b_1}{v}\right) \dots \dots \dots (5)$$

His paper, published in *Wiedemann's Annalen*, Bd. xii. p. 127, was inserted in the German and English versions of Van der Waals's pamphlet "On the Continuity of the Liquid and Gaseous States of Matter," at the end of the sixth chapter.

Considered as a determination of the factor, with which the total volume  $b_1$  of the particles, when introduced in  $v - b_1$ , is to be multiplied, our results were identical, and confirmed the opinion expressed by Van der Waals about the value of this coefficient. Mr. Lorentz viewed his results in no other light, and had no intention at all to substitute his formula (5) for that given by Van der Waals. Indeed, in the passage of his paper which I quote here, he clearly indicates the weak point of his calculation:—"Strictly speaking, a correction ought to be made here, indicated by Mr. Van der Waals; in calculating the number of encounters, the extension<sup>1</sup> of the molecules should have been taken into account. The matter is simplified, however, if the influence of the virial arising from the repulsive forces, or the size of the molecules, is small; and if a correction to the first order is sufficient, then the uncorrected value of the number of encounters may be used in calculating the small repulsive virial."<sup>2</sup>

Now it is not impossible to apply to Lorentz's formula the correction alluded to in this passage. In 1875 I calculated for the first time,<sup>3</sup> by a more rigorous method, the shortening of the mean free path of spherical particles, in consequence of their extension in the direction of motion. Some months later, Mr. Van der Waals succeeded in the same calculations by a somewhat different method, extending it to the case of two sets of particles of different diameters. Both calculations lead to the same result, viz. that the mean free path is shortened in the proportion  $v : v - 4b_1$ ; therefore the number of the collisions, and the term in the virial equation dependent upon these collisions, must be augmented in the reciprocal proportion; but then this equation takes the form—

$$\rho v = \frac{1}{2}\Sigma mu^2 \left(1 + \frac{4b_1}{v} \cdot \frac{v}{v - 4b_1}\right) = \frac{1}{2}\Sigma mu^2 \cdot \frac{v}{v - 4b_1} \dots (6)$$

and becomes identical with the equation (3) of Van der Waals.<sup>3</sup>

In this manner the true formula is obtained by means of the virial equation, as it has been by the method of economized distances, and these verifications of the equation derived by Van der Waals are not without importance. Indeed, I always held the opinion that it is not quite allowable to conclude directly from the diminution of the free path of the molecule to a proportional augmentation of the pressure on the bounding walls. The number of the mutual encounters of the molecules, and the number of their collisions with the walls (or, rather, their passages through an ideal plane), are not

<sup>1</sup> The extension in the direction of the motion is meant here. I have translated the first phrase from the original paper in *Wied. Ann.*, where it runs: "Streng genommen müsste man also hier eine Correction anbringen, wie sie von Herrn van der Waals angegeben würde; man hätte nämlich bei der Stosszahl die Grösse der Molecule zu berücksichtigen."

<sup>2</sup> *Verslagen en Mededeelingen*, a Reeks, Deel x; *Archives Néerlandaises*, t. xii.

<sup>3</sup> I owe this remark to a verbal communication by Van der Waals.

proportional numbers under all circumstances. A change in the shape of the molecules, or an augmentation of their diameters, will affect the first number in a much greater proportion than the second. But, as I have shown, the equation of Van der Waals holds good, independently of this assumption.

D. T. KORTEWEG.

Amsterdam, November 4.

#### THE BIRD-GALLERY IN THE BRITISH MUSEUM.

A LONG-NEEDED and much-wished-for reform, to which the attention of naturalists should be specially invited, has been commenced in the Bird-gallery of the British Museum. Under the old régime at Bloomsbury, the rule was, as it is even now in most of the Continental Museums, that every specimen should be stuffed, and exhibited in the public gallery. The natural, if not the necessary, consequence of such a rule is that, as time progresses, the shelves become crowded with badly mounted specimens, which are very displeasing to the general observer, and most inconvenient to the scientific worker.

In the British Museum, however, the idea of mounting every specimen has been long ago abandoned. The main collection for scientific work is, we need hardly say, that of skins. These are arranged in cabinets, in numbers which it would be impossible to find space for if "mounted." When thus disposed of they are much more easy to find, and more convenient for examination, than "mounted" specimens. Though it may be sometimes necessary to refer to the Bird-gallery, the working ornithologist of this country, as a rule, uses only the skin collection.

This being so, the question arises as to what is the best way of making the Bird-gallery useful, and attractive to the general public. As to this there can be no question, it appears, that the Bird-gallery should be fitted up as an "Index Museum," and should contain a series of the principal types of bird-life arranged in systematic order from the highest to the lowest. Every family should be placed in a separate case, in its proper position between the two groups to which it is most nearly allied. In each family a series of well-mounted specimens should illustrate the principal sub-families and genera, and the male and female and other plumage of the leading species. Nests and eggs should be added to show the mode of nidification, and maps to show the areas of distribution. Diagrams and preparations of particular structures should be placed at the head of each group, to exhibit its special peculiarities; and finally, every specimen and diagram should be clearly labelled and explained. It will readily be understood that a Bird-gallery filled up in this way would be a most instructive object, and much more useful and attractive than the crowded rows of uniformly-set-up specimens that are offered to view in most public Museums. Some such plan as this, we take it, is what the authorities of the British Museum have now in view.

For a commencement, the family of Woodpeckers has been selected, and a case devoted to its illustration has been fitted up. A series of well-mounted specimens shows the leading forms of the group, and diagrams, preparations, and maps exhibit its principal peculiarities and the distribution of the species.

This is at present only the beginning of a very important change of plan. But there can be no question that if the scheme is carried out, and the whole Bird-gallery is treated in a similar way, an admirable reform will have been effected.

#### THE OCTOBER ERUPTION NORTH-WEST OF PANTELLERIA.

SOME time after the news arrived in this country of the volcanic outburst in the neighbourhood of Pantelleria, my friend Mr. Gerard Butler, F.G.S., undertook to visit the island, and to investigate the interesting phenomena that were being exhibited there. Mr. Butler has now returned, having made a large collection of specimens of rocks and minerals, and I trust that before long we shall have fuller information concerning this remarkable district. The following short note embodies the general results of his inquiries concerning the recent eruptions; but telegrams received since his return state that renewed outbursts have led to the formation of an island at the spot, and mariners have been warned to avoid it.

JOHN W. JUDD.  
Royal College of Science, London, December 14.

In NATURE of December 3 (p. 120), a short sketch is given of a paper by M. Ricco on the above, which those interested in the subject may read in the *Comptes rendus* for November 25.

It may be worth while for one who visited Pantelleria soon after the eruption to point out that there appears to be no foundation for the idea conveyed by many English accounts and by the words "island," "erupted island," in NATURE (*loc. cit.*), that an island comparable to Graham's Island was formed.

It seems that by a submarine eruption which, after prefatory earthquakes between October 14 and 17, was first observed on the latter day, about 5 kilometres to the north-west of Pantelleria, a narrow band of floating bombs, extending for about a kilometre in a north-east and south-west direction, was produced.

The persistence during the eruption of this linear band may perhaps indicate the line of fracture of the sea bottom.

There appears to have been always deep water at the scene of eruption. Ricco tells us that soundings at the middle and ends of the floating shoal of bombs found no bottom at 320 metres.

The brittle cindery bombs readily broke up, giving vent to the superheated steam they contained; when, or upon their becoming otherwise waterlogged, they sank, so that, on October 26, soon after the eruptive action ceased, all traces of it had disappeared in deep water.

G. W. BUTLER.

#### NOTES.

WE regret to have to record the death of Prof. Stas, the eminent Belgian chemist. He died at the age of seventy-eight.

At last Thursday's meeting of the Royal Society, the President read from the chair a letter from Prof. Dewar, which had been put into his hand as he entered the meeting-room, in which Prof. Dewar stated that he had at 3 p.m. that afternoon "placed a quantity of liquid oxygen in the state of rapid ebullition in air (and therefore at a temperature of  $-181^{\circ}$  C.) between the poles of the historic Faraday magnet in a cup-shaped piece of rock salt (which is not moistened by liquid oxygen and therefore keeps it in the spheroidal state)," and to his surprise, Prof. Dewar saw the liquid oxygen, as soon as the magnet was stimulated, "suddenly leap up to the poles and remain there permanently attracted until it evaporated."

ACCORDING to information sent to Berlin, Emin Pasha and Dr. Stuhlmann, travelling in the region between Lakes Victoria, Tanganyika, and Albert Edward, have discovered what they take to be the ultimate source of the Nile. This is a river called Kifu, which is supposed to have its sources in the Uhha country, lying to the east of the northern part of Lake Tanganyika,

about 4° of south latitude. It flows into the southern end of Lake Albert Edward.

THE death of Dr. F. C. Dietrich, Keeper of the Botanical Museum at Berlin, is announced. He was eighty-six years of age.

AT the annual general meeting of the Institution of Electrical Engineers on Thursday, December 10, Prof. Ayrton was elected President for the coming year. The following are the Vice-Presidents: Alexander Siemens, R. E. Crompton, Sir David Salomons, and Sir Henry Mance. In moving the adoption of the annual report, Prof. Crookes said that the number of members elected during the past year was greater than in almost any previous year. He announced that Prof. Nikola Tesla is on his way to England, and had promised to lecture before the Institution in January next. Prof. Crookes added that the Council would spare no pains to insure that the lecture should be thoroughly well experimentally illustrated. Mr. W. H. Preece, F.R.S. (Past-President), read a paper on "The Specification of Insulated Conductors for Electric Lighting and other Purposes." In this paper the fallacy of the present mode of specifying electric light conductors was exposed, and a new standard of insulation, based on the well-known qualities of gutta-percha, was proposed. The qualities of the numerous insulating materials now in the market were measured and determined in this new standard, and it was shown that any classification of cables should be based on the pressures to be resisted, and should depend on the thickness of the insulating wall. The introduction of cheap and nasty cables, owing to competition and the absence of specification and inspection, was strongly commented on. It was shown that all danger was eliminated by the use of proper material and proper design. The paper concluded with the recital of Mr. Preece's latest specification.

PROF. A. HANSEN, of Darmstadt, has been appointed to the Professorship of Botany and Directorship of the Botanic Garden at Giessen.

PROF. E. WARNING, of Copenhagen, is at present engaged on a botanical expedition to the West Indies and Venezuela. Herr G. Schweinfurth and Prof. O. Penzig have returned from their journey in Abyssinia; and Herren J. Bornmüller and Sintenis from their botanical expedition, in the course of which they have visited the island of Thasos, Mount Athos, and the Thessalian Olympos.

THE following are the lecture arrangements of the Royal Institution before Easter, so far as they relate to science:—Prof. John G. McKendrick, six Christmas lectures to juveniles, on life in motion, or the animal machine; Prof. Victor Horsley, twelve lectures on the structure and functions of the nervous system (the brain); Prof. E. Ray Lankester, three lectures on some recent biological discoveries; Dr. B. Arthur Whitelegge, three lectures on epidemic waves; Prof. J. A. Fleming, three lectures on the induction coil and transformer; the Right Hon. Lord Rayleigh, six lectures on matter, at rest and in motion. The Friday evening meetings will begin on January 22, when a discourse will be given by the Right Hon. Lord Rayleigh, on the composition of water; succeeding discourses will probably be given, among others, by Sir George Douglas, Prof. Roberts-Austen, Mr. G. J. Symons, Prof. Percy F. Frankland, Sir David Salomons, Prof. L. C. Miall, Prof. Oliver Lodge, Mr. John Evans, and Prof. W. E. Ayrton.

LAST week a deputation of gentlemen interested in the University Extension movement had an interview with Lord Cranbrook, President of the Privy Council, to ask for a Government grant in aid of the local lectures delivered under the auspices of

the organizing bodies. Among those present were Sir George Stokes, Prof. Bryce, Prof. Jebb, Mr. James Stuart, the President of Magdalen College, Oxford, the Master of University College, Oxford, and the Master of Selwyn College, Cambridge. Lord Cranbrook reminded the deputation that his official duties related only to public elementary schools, and that a Government grant could be obtained for the University Extension movement only from the Treasury. He expressed sympathy, however, with the objects of the movement, and promised to consider carefully and to bring before his colleagues the arguments advanced by the deputation. Referring to the general question of secondary education, Lord Cranbrook said it was most desirable that clever boys and girls who have passed through the elementary course should be enabled, by bursaries or in some other way, to go to intermediate schools, and thus be prepared for such instruction as is offered by University Extension lecturers. He feared, however, that those who expected this object to be attained by means of a Government grant might "have to wait for some time."

ON the invitation of the Council of the Photographic Society of Great Britain, Mr. Leon Warnerke lately undertook to submit to the Society a description of the photographic technical schools on the Continent. With that object in view he visited, during last summer, Belgium, Germany, Austria, and Russia, taking notes with pencil and camera. The results are embodied in an interesting paper which was read at a recent meeting of the Society, and is now printed in the *Photographic Journal*.

THE organizing joint committee of the Essex County Council and the Essex Field Club on technical instruction have issued a circular announcing that they have resolved to appoint a certain number of lecturers on science subjects. The services of these teachers are offered free (with the exception of travelling and hotel expenses of the lecturers, where necessary) to local technical instruction committees, under certain conditions to be settled hereafter; the local committees guaranteeing audiences or classes of students (not less than twenty in number), providing rooms, gas, &c., and defraying all necessary local expenses. Syllabuses of short courses of lectures already approved are sent with the circular. They relate to elementary vegetable physiology, economic entomology, and elementary practical mechanics.

THE Royal Commission for the Chicago Exhibition are anxious to comply with a request made to them by the executive authorities of the Exhibition, that a typical collection of economic British minerals may be included in the British Section, and they are now applying to owners and managers of mines, asking for specimens of the principal British minerals. Mr. B. H. Brough, the Instructor in Mine-surveying at the Royal College of Science, South Kensington, has kindly undertaken to classify and arrange the collection, and any suitable specimens may be addressed to him. What is required is not specimens of special value or rarity, but samples of ordinary ores, &c., so that the collection when complete may be fully illustrative of the mineral resources of the kingdom. At the close of the Exhibition the collection will be presented to an American Museum.

PROF. H. A. HAZEN, acting under instructions from the U.S. Weather Bureau, is in Chicago preparing a report on its weather—the mean temperature, the winds, snows, showers, humidity, early frosts and late snows. The report will be based on all the observations and records made for the last fifty years the object being to convince everyone interested in the approaching Exposition that Chicago is exceptionally favoured in point of fine weather.

MR. ROSEWATER, who was a distinguished member of the U.S. Military Telegraph Corps during the American civil war, and is now President of the Old Timers Telegraphic Association, has lately been studying the various Government telegraph systems in use in Europe. The results of his investigations will shortly be submitted to what is expected to be an unusually interesting and important meeting of the New York Electric Club.

A COPY of "Whitaker's Almanack for 1892" has been sent to us a few days in advance of publication. Great care has been taken, as usual, to keep the Almanack up to date. Additional space is devoted to educational matters, and for the first time educational progress and occurrences are dealt with in a separate article. There is also a separate article on agricultural education. Other subjects separately treated are the rise, progress, and achievements of the great lines of ocean steamers, naval gunnery, and the results of the census. Of course, various sections resemble in subject those of former years, but even these are for the most part entirely fresh in substance. In many instances the changes wrought during the interval of a single year are so numerous that scarcely a line of the section in which the subject is treated remains unaltered.

OWING to his declining to take up his residence in Rio de Janeiro, Dr. Fritz Müller, of Blumenau, Sta. Catharina, has been summarily dismissed by the new Government of Brazil from his post of "Naturalista viajante" to the Museum at Rio de Janeiro. The great services which Dr. Müller has rendered both to zoological and botanical science during his forty years' residence in Brazil are too well known and too widely acknowledged to need dilating on. Dr. F. Müller is now close on completing his seventieth year; and Dr. Karl Müller, of Halle, the editor of *Natur*, proposes to seize the opportunity of collecting from his fellow-naturalists some substantial recognition of the honour in which he is held.

DR. H. E. HAMBERG has communicated to the Swedish Academy of Sciences a paper on the radiation of the upper clouds round barometric minima, prepared from the cloud observations available at Upsala Observatory for the years 1874-89. The arrangement of the highest clouds—cirrus and cirro-stratus—in the form of parallel bands has long been noticed by meteorologists in this country, and various papers on the subject have been written by Mr. W. C. Ley, MM. Hildebrandsson, Köppen, and others; and the movements of these clouds, in conjunction with the wind prevailing at the earth's surface, are at times sufficient to determine approximately the direction in which an atmospheric disturbance exists, even without the use of synoptic charts. For instance, a barometric minimum often exists in a direction nearly perpendicular to that of the radiation, and, generally, on that part of the horizon where the bands of upper clouds are most dense, or whence they seem to radiate, but it is always necessary to take into account the direction of the wind at the earth's surface. The author draws the following conclusions from his investigation:—(1) The radiation of the upper clouds is closely connected with barometric minima. (2) Near a barometric minimum, with the pressure below 29.9 inches, the radiation forms with the radius of the depression an angle of about 70°, the deviation of the radiation from the direction of the surface wind being positive (*i.e.* to the right), by some degrees, on the south-west of the barometric minimum, and negative on the south-east of it. (3) Further from the barometric minimum, with a pressure of 29.9 inches and above, the inclination to the radius is rather greater, about 75°, except where the barometric minimum lies to the north of the place of observation, in which case it is much lower. (4) The angle formed by the radiation is generally greater in the rear of a barometric minimum, reaching nearly 90° in a high pressure; on

the other hand, it is smaller in front, especially to the south-east of a minimum, and further from the centre. (5) Compared to the general circulation of the air in a barometric minimum, the radiation of the upper clouds most resembles the direction of the wind near the earth's surface. The meaning of this last sentence is not obvious; but the other conclusions agree, on the whole, with the views of other meteorologists who have studied the subject.

THE *Meteorologische Zeitschrift* for November contains a summary, by Dr. J. Hann, of the meteorological observations taken at Cairo from 1868-88. The observations have been published *in extenso*, together with a good introduction upon the climate, in the Bulletin of the Egyptian Institute, and although similar observations have occasionally been published before, the present series contains much new and useful material. The most striking feature in the climate of this part of Egypt is the *Chamsin*, the hot and dust-bearing wind which makes its appearance in March or April for about three to four days at a time, and robs a large portion of the trees of their leaves. In the intervals during which this wind is not blowing the weather is pleasant and clear during spring-time, and the nights fresh and calm. During the summer the north winds prevail, with high temperature, very clear air, and great dryness. Towards September humidity appears with the rise of the Nile, the ground is at times covered with heavy dew, and the heat becomes oppressive on account of the moisture. In October and November fog occasionally occurs in the morning, and rain begins to fall. After this season the temperature is uniform and pleasant. Snow is unknown, frost very seldom occurs, and rain is not very frequent. The absolute maximum temperature of the 21 years period was 117° in August 1881, which was also closely approached in May 1880, *viz.* 116°·4. The absolute minimum was 28°·4 in February 1880, and the mean annual temperature was 70°·5. Rainfall is only given for the years 1887-88, in which 0.87 and 1.67 inches fell respectively. The relative humidity sinks at times even on a daily average to 12 per cent., and has been known to fall as low as 3 per cent. at certain hours. Thunderstorms and hail are very rare. The original work contains a long investigation on the connection between the height of the Nile and the weather, a comparison between the present climate and that at the beginning of this century, and several carefully prepared diagrams referring to all meteorological elements.

THE refraction and velocity of sound in porous bodies allowing passage of sound, such as sponge, wadding, felt, &c., have been recently made a subject of investigation by Herr Hesehus (*Rep. der Physik*). His plan was to make a plane-convex spherical lens of iron wire net, and fit it, filled with the porous body (variously condensed), into an aperture in a screen. A pipe of variable tone was sounded on one side, and the behaviour of a sensitive flame noted on the other. From the distance of the focus, when found, could be deduced the refractive index and the velocity in the lens. The refrangibility grows with increasing density of the porous substance, while the velocity on the average is lessened; the latter is also less, the greater the sound-wave. The author gives details of experiments in which the velocity varied from 146 to 261 metres per second (with ebonite shavings). From an empiric formula which he gives, he makes deductions regarding the propagation of sound in tubes, considered as only a special case of its spread through the pores and passages of a porous body. He hopes further research in this field may do something to elucidate the passage of light and electricity through media.

THE Report of the United States Commissioner of Education has been submitted to the Secretary of the Interior. It says that the usefulness of the Bureau depends directly upon what it

prints and publishes, and therefore urges an appropriation of 30,000 dollars for general printing for the fiscal year 1892-93, and makes a special request for a specific appropriation of 20,000 dollars to continue the series of educational histories of the several States. The Commissioner reports that there were enrolled in 1889-90 in the public schools of the United States of elementary and secondary grade 12,686,973 pupils, as against 9,867,505 in 1880. The enrolment formed 20·27 per cent. of the population of 1890. The average daily attendance of pupils on each school day in 1890 was 8,144,938. The whole number of public school teachers in the past year was—males, 125,602; females, 233,333. The total amount expended during the past fiscal year for public school purposes was 140,277,484 dollars, is against 63,396,666 dollars in 1870, and 78,004,687 dollars in 1880. The expenditure per capita of population in 1880 was 1·56 dollars, while in 1890 it was 2·24 dollars.

The U.S. Bureau of Education has issued, as one of its "Circulars of Information," an excellent paper on "Sanitary Conditions for School-houses," by Albert P. Marble, Superintendent of the Public Schools of Worcester, Mass. Dr. Marble has for many years studied the problems of ventilation, heating, lighting, draining, and school-house construction; and his suggestions are well worthy of consideration in this country, as well as in America. The value of the Circular is increased by an appendix, in which are given a number of designs of school buildings of various sizes, carefully selected with a view to commodiousness, healthfulness, and economy of construction. In an official statement prefixed to the Circular, attention is especially called to a series of nineteen plates constituting the prize designs selected and published by the State of New York in 1888.

In the interesting paper on insectivorous plants, read before the Royal Horticultural Society on September 22, 1891, and now published in the Society's Journal, Mr. R. Lindsay refers to the experiments by which Mr. Francis Darwin has shown the amount of benefit accruing to insectivorous plants from nitrogenous food. Mr. Lindsay says his own experience in the culture of *Dionæa* is that when two sets of plants are grown side by side under the same conditions in every respect, except that insects are excluded from the one and admitted to the other, the latter, or fed plants, are found to be stronger and far superior to the former during the following season. He points out the importance of remembering that the natural conditions under which these plants are found are different from what they are under cultivation. In their native habitats they grow in very poor soil and make feeble roots, and under these conditions may require to capture more insects by their leaves to make up for their root deficiency. Under culture, however, fairly good roots for the size of plant are developed. "Darwin," says Mr. Lindsay, "mentions that the roots of *Dionæa* are very small: those of a moderately fine plant which he examined consisted of two branches, about one inch in length, springing from a bulbous enlargement. I have frequently found *Dionæa* roots six inches in length; but they are deciduous, and I can only conjecture that the roots mentioned by Darwin were not fully grown at the time they were measured. What is here stated of the natural habits of *Dionæa* applies more or less to all insectivorous plants."

GOOSEBERRIES are so much liked by most people that it is very desirable the season for them should, if possible, be prolonged. According to Mr. D. Thomson, who has a good paper on gooseberries in the current number of the Journal of the Royal Horticultural Society, this can be done easily in the northern part of Great Britain. At Scotch shows it is quite usual to see fine fresh gooseberries about the middle of September. These, as a rule, are gathered from ordinary bushes that have perhaps

been shaded with mats or canvas after becoming ripe. The best way to lengthen out the season of gooseberries, Mr. Thomson says, is to plant a portion of a wall with a due north aspect with some Warringtons, and train them on the multiple-cordon system, and keep the laterals spurred in precisely the same way as is adopted with red currants on fences or walls, or in fact with gooseberry bushes grown in the ordinary way. The main shoots should not be closer than 10 inches. If a coping of wood be placed on the wall to throw off wet, a net being used to protect the fruit from birds, the gooseberries can be kept fresh till far into October, and are then very useful and acceptable.

THE authorities responsible for the working of the free public libraries of Manchester cannot complain that these institutions are inadequately appreciated. From the Thirty-ninth Annual Report on the subject to the Council of the city we learn that, during the year ended September 5, 1891, the number of visits made by readers and borrowers to the Manchester libraries and reading-rooms reached an aggregate of 4,327,038, against a total for the preceding twelve months of 4,195,109. The number of volumes lent for home reading was 702,803. Of these, only thirteen are missing.

At a recent meeting of the Chemical Section of the Franklin Institute, Dr. Bruno Terne read a paper on the utilization of the by-products of the coke industry. In the course of his remarks he said it seemed strange, and nevertheless was a fact, that, with all the ingenuity of the American people in the advancement of the purely mechanical part of the technical industries, they have been and are still slow in the development of chemical industries. "If," said Dr. Terne, "you will visit our coal region to-day, you will find the nightly sky illumined from the fires of the coke ovens, and every one of the brilliant fires bears testimony that we are wasting the richness of our land in order to pay the wiser European coke manufacturer, who saves his ammonia and sends it to us in the form of sulphate of ammonia; and who also saves his tar, which, after passing through the complex processes of modern organic chemistry, reaches our shores in the form of aniline dyes, saccharin, nitrobenzol, &c." Dr. Terne thinks that every pound of ammonia used in America ought to be produced there, and that every pound of soda should be made from American salt wells by the ammonia process.

MR. COLEMAN SELLERS contributes to the December number of the *Engineering Magazine*, New York, the first of a series of articles on what he calls "American Supremacy in Mechanics." Incidentally, he notes that most English inventions brought to the United States have to be "Americanized, simplified, made accessible in the case of machinery, and constructed with a view to ease of repair as well as to durability when under the care of careless attendants." Mr. Sellers does not think it would be worth the while of Americans to copy "the solidity and immense weight that some deem a merit in English machinery."

ACCORDING to the "World's Fair Notes," sent to us from Chicago, the party which, under the direction of Mr. Putnam, has been making excavations in the mounds of Ohio, made an important discovery on November 14. While at work on a mound 500 feet long, 200 feet wide, and 28 feet high, the excavators found near the centre of the mound, at a depth of 14 feet, the massive skeleton of a man incased in copper armour. The head was covered by an oval-shaped copper cap; the jaws had copper mouldings; the arms were dressed in copper, while copper plates covered the chest and stomach, and on each side of the head, on protruding sticks, were wooden antlers ornamented with copper. The mouth was stuffed with genuine pearls of immense size, but much decayed. Around the neck was a necklace of bears' teeth, set with pearls. At the side of this skeleton was a female skeleton.

ACCORDING to a telegram received in New York from Mexico, the Mexican Government has ordered the inhabitants of the villages in the neighbourhood of the town of Colima to abandon their homes and seek refuge elsewhere, as the volcano in the vicinity, which was recently in eruption, shows signs of fresh activity, and the country for miles around it is illuminated by the flames issuing from the crater.

THE census of 1890 in Austria-Hungary shows that the rate at which the population increased during the preceding ten years was very different in the two great divisions of the Monarchy. The increase in so-called Cisleithania was 7.9 per cent.; in Transleithania, 10.82 per cent. In the individual provinces the increase was very unequal. In Lower Austria it was 13.8 per cent., this high rate being due to the attractive force of Vienna. Then came Bukowina with 13.1 per cent.; Galicia, 10.4 per cent.; Silesia, 6.5 per cent.; Moravia, 5.5 per cent.; Bohemia, 5 per cent.; the Alpine lands, from 3.2 to 3.6 per cent.; and Tyrol, 0.9 per cent. A different set of figures is yielded by the increase of the various nationalities. Among these the Poles stand highest, with 15 per cent.; then the Serbo-Croats, 14 per cent.; the Ruthenians, 11 per cent.; the Germans, 5.66 per cent.; the Czechs, 5.05 per cent.; the Slovenians, 3.18 per cent.; and the Italians, under 1 per cent.

MR. HENRY LAVER records in the current number of the *Zoologist* the capture of a spotted eagle at Elmstead, near Colchester, on October 29, 1891. On that day a farm labourer saw a strange bird, evidently in an exhausted condition, alight in the field in which he was working. When he went after it, it rose, and flew about a hundred yards. He soon came up to it, and, after some little difficulty, from its pugnacity, captured it alive and uninjured, and in a few days sold it to a gipsy, who in turn disposed of it to Mr. Pettitt, the local taxidermist. Mr. Laver says its plumage appears to indicate good health, and that its appetite favours that idea. If any injury led to its capture, all marks of it have quite disappeared.

THE new instalment of the Transactions of the Leicester Literary and Philosophical Society (vol. ii. part ix.) contains an abstract of an interesting lecture by Mr. Harold Littledale, of the College, Baroda, on some of his experiences with big game in India. Mr. Littledale gave an especially good account of shooting in the Himalayas. The ibex and markhor were found at altitudes varying from 10,000 to 20,000 feet, and could be obtained only by perseverance in the face of many dangers and obstacles. Of the markhor (*Capra megaceros*), a splendid animal which is becoming increasingly rare, he obtained ten examples, and ibex had also fallen to his gun, with 45 inch horns—the maximum development being about 52 inches. Various species of sheep also occurred, as the magnificent *Ovis poli*, which the lecturer had not yet met with, *Ovis ammon*, *Ovis cycloceros*, &c. The chamois was found commonly in the Himalayas, and Hodgson's antelope could be shot at elevations of 20,000 feet. Amongst the other mountain animals described were the snow leopard, Sikkim stag, and musk deer (*Moschus moschiferus*), with its tusks about 5 inches in length.

MR. W. H. ROSSER has written for the benefit of candidates preparing for the Board of Trade examinations a general explanation of what is usually known as the "Compass Syllabus." It is entitled "Compass Deviation: a Syllabus of Examination in the Laws of Deviation, and in the Means of Compensating it," and is published by Messrs. James Murray and Son. The pamphlet is to be regarded as an appendix to Mr. Rosser's "Deviation of the Compass considered practically."

MM. H. LÉVEILLÉ AND A. SADA, of Pondicherry, have started a new botanical journal with the title *Le Monde des Plantes: Revue Mensuelle de Botanique*. The first number appeared on October 1. It is published at Le Mans (Sarthe).

THE Council of the Owens College have published the first volume of "Studies in Anatomy." It is edited by Prof. A. H. Young, and presents a part of the results of investigations conducted in the anatomical department of the College during the last three or four years.

MESSRS. BAILLIÈRE, TINDALL, AND COX have issued a second edition of Dr. Edridge-Green's work on "Memory: Its Logical Relations and Cultivation."

A NEW edition of "Falling in Love: with other Essays on More Exact Branches of Science," by Mr. Grant Allen, has been published by Messrs. Smith, Elder, and Co.

MESSRS. BEMROSE AND SONS have issued a second edition of a "Hand-book to the Geology of Derbyshire," by the Rev. J. Magens Mello. The work has been rewritten, and is illustrated with a map and sections.

A CURIOUS compound of lead, sodium, and ammonia,  $Pb_4Na_2NH_3$ , is described by M. Joannis in the current number of the *Comptes rendus*. M. Joannis has been studying the nature and reactions of the substance known as sodammonium, obtained by dissolving metallic sodium in liquefied ammonia. The deep blue liquid thus produced has been shown in a previous communication (see NATURE, vol. xliii. p. 399) to decompose slowly at the ordinary temperature into hydrogen gas and sodamide, a compound of the composition  $NaNH_2$ , which M. Joannis isolated in the form of colourless crystals. That such a compound as sodammonium ( $NaNH_2$ ), really exists in the blue solution in liquefied ammonia would appear to be the most natural assumption from these experiments. The reactions of sodammonium now described lend additional support to this view. When a rod of pure lead is placed in a saturated solution of sodammonium in water, the reddish-brown liquid becomes rapidly blue, and finally assumes a deep green tint. A small quantity of hydrogen is evolved at the same time owing to the decomposition of a portion of the sodammonium into sodamide, as above described. The lead gradually disappears, and a solid substance possessing an indigo-blue colour is deposited. This blue substance is found upon analysis to consist of the compound  $Pb_4Na_2NH_3$ , and would appear to be a sodammonium in which a portion of the sodium is replaced by lead. It dissolves readily in liquefied ammonia with formation of a solution possessing a bottle-green tint. It is not very stable, dissociating spontaneously on standing, with production of a grey substance very much resembling spongy platinum. Upon exposure to air it becomes warm owing to its rapid oxidation. It behaves in a somewhat remarkable manner towards water. When introduced in small quantities at a time into ordinary water, the first portions dissolve completely, the oxygen dissolved in the water oxidizing the lead to litharge, which at once dissolves in the alkaline solution formed. As soon, however, as the oxygen in the water is used up, further additions of the substance result in the precipitation of black flocculæ of metallic lead. Another interesting reaction of sodammonium is that with metallic mercury, which behaves in an entirely different manner from lead. When the solution of sodammonium in liquefied ammonia is poured over a globule of mercury, rapid action occurs, with the ultimate elimination of the whole of the ammonia, and production of a sodium amalgam of the composition  $NaHg_6$ , which has been obtained in well-formed crystals. This reaction is the more interesting inasmuch as M. Berthelot, from purely thermo-chemical considerations, has previously indicated the possible existence of such a compound of sodium and mercury.



THE additions to the Zoological Society's Gardens during the past week include a Sooty Mangabey (*Cercocebus fuliginosus* ♀) from West Africa, presented by Mr. H. E. Dampier, J.P.; a Rufous-necked Weaver-Bird (*Hyphantornis textor* ♂) from West Africa, presented by Commander W. M. Latham, R.N., F.Z.S.; a White Stork (*Ciconia alba*), European, presented by Mr. Walter Chamberlain, F.Z.S.; eighteen Grenadier Weaver Birds (*Euplectes oryx*), ten Golden-backed Weaver Birds (*Pyromelana aurea*), nine Black-capped Weaver Birds (*Hyphantornis nigricaps*), four Red-bellied Waxbills (*Estrela rufiventris*), three Triangular-spotted Pigeons (*Columba guinea*), four Dwarf Chameleons (*Chameleon pumilus*) from South Africa, presented by Mr. R. W. Murray.

OUR ASTRONOMICAL COLUMN.

JUPITER AND HIS FIRST SATELLITE.—A series of observations of spots and markings on the planet Jupiter were communicated to the Royal Astronomical Society at the November meeting by Mr. Barnard. A careful study of numerous details observed during a period of twelve years has led to the conclusion "that the red colour of any of the markings is an indication of their age; or in other words, when a spot or marking (other than the white spots) first appears it is dark or black, but after some time turns red." Several examples are given of this transition, and the great red spot seems to be no exception to the rule. Measurements of transits of the broken chain of small black spots just north of the north equatorial belt, discovered by Mr. Barnard during the present year, show that the spots have a very large relative motion, for they complete a revolution around Jupiter in about thirty-seven days. The oblong dusky spot discovered near the great red spot last year is diminishing its longitude by about 0° 54 per day, and so completes a revolution relatively to the latter in about 167 days. This, and other new red markings in the southern hemisphere, seem to have their origin in the region of the great red spot. Their period of rotation is about the same as the round white spots in the same hemisphere, the longitudes of which diminish by about 0° 6 per day. The observations show that the great red spot is stationary in longitude, and possibly shorter and broader now than in 1880. Further observations of the first satellite have been made in order to throw light upon the apparent duplicity of this body in transit, distinctly seen by Mr. Barnard on September 8, 1890. It is noted:—"The phenomena seen on these occasions would rather discourage the idea of actual duplicity. At these times the satellite has appeared egg-shaped when in relief on the dark belt. . . . I am confident that this particular phase, and perhaps also that of apparent duplicity, is explained by a bright belt on the satellite or by darkness of the polar regions, which is the same thing." Mr. Stanley Williams has suggested that the phenomenon observed on September 8, 1890, may have been due to the satellite having been seen in transit as a dark spot close to a dark spot on the surface of Jupiter which transited at the same time.

SPECTRA OF THE SUN AND METALS.—Some extremely fine comparative photographic spark-spectra of the sun and metallic elements were exhibited by Mr. F. McClean at the meeting referred to in the above note. The spectra extend, in six sections, from  $\lambda$  3800 to  $\lambda$  5750—that is, from about L of the solar spectrum to near D. They are divided into two series—one containing spectra of the sun, iron, platinum, iridium, osmium, palladium, rhodium, ruthenium, gold, and silver; the other containing spectra of the sun, iron, manganese, cobalt, nickel, chromium, aluminium, and copper. The scale of wave-length adopted is that of Ångström's map. Since the spark was taken in air all the spectra have air-lines running through them. The purest materials obtainable were used as electrodes: nevertheless a large number of lines due to foreign substances appear on the photographs. The commonest impurity is calcium, its lines being present in very nearly all the spectra. No attempt has been made to eliminate the lines having their origin in such impurities; hence, as Mr. McClean remarks, it is impossible "to obtain any complete results from these two series of photographs alone. Photographs of the spectra of all the common oxidizable metals, and particularly of calcium, barium, magnesium, and titanium are first required."

*Astronomische Nachrichten*, No. 3068, contains the following ephemeris for the comet Tempel<sub>3</sub>-Swift for 12h. Paris mean time:—

1891.	h.	m.	s.	δ.	Log Δ.						
Dec. 17	...	1	38	47	...	+27	4	45	...	9	4220
18	...	46	1	...	...	...	13	33	...	...	...
19	...	53	10	...	...	...	21	1	...	9	4339
20	...	2	0	13	...	...	27	3	...	...	...
21	...	7	10	...	...	...	31	55	...	9	4467
22	...	14	1	...	...	...	35	32	...	...	...
23	...	20	44	...	...	...	38	4	...	9	4606
24	...	27	19	...	...	...	39	24	...	...	...
25	...	33	47	...	...	...	39	50	...	9	4753
26	...	40	7	...	...	...	39	18	...	...	...
27	...	46	19	...	...	...	37	59	...	9	4907
28	...	52	22	...	...	...	35	47	...	...	...
29	...	58	17	...	...	...	32	57	...	9	5068
30	...	3	4	5	...	...	29	24	...	...	...
31	...	9	43	...	...	...	25	2	...	9	5235

*Astronomische Nachrichten*, No. 3069, contains a paper by Prof. Pickering on the distribution of energy in stellar spectra. Since stellar magnitudes obtained by various processes, such as photography, eye-observations, &c., cannot be compared when the light of stars is of different colours, the method he proposes is to adopt a single wave-length in the spectrum to which all intensities should be referred, a curve or series of numbers being necessary to give a measure of the rays of each different wave-length. For rays of different wave-lengths he says: "The intensities may be determined by comparing the densities of different portions of the photographic spectrum." The line fixed upon was that of the hydrogen line G, "as it is near the centre of the photographic spectrum." The photographs he employed were those forming part of the Henry Draper Memorial, all taken under similar conditions, and in each one separately twenty points were taken and compared by comparison with a standard photographic wedge. Each of the measures thus obtained was converted into logarithmic intervals, and the measure, corresponding with that of the hydrogen line G of wave-length 434, was deducted. By subtracting the values of the logarithm of the energy of the solar light, the remainder showed "the excess or deficit of energy of the star as compared with that of the sun, eliminating the various sources of error enumerated above." In the table below we give the results for three stars as obtained by Prof. Pickering:—

λ.	Log E.	α Can. Maj.	α Aur.	α Orion.	E.			
390	...	-0'26	+0'37	+0'32	...	-0'57	...	0'55
400	...	-0'19	+0'10	+0'08	...	-0'38	...	0'65
410	...	-0'12	+0'10	+0'03	...	-0'23	...	0'76
420	...	-0'07	+0'00	+0'01	...	-0'11	...	0'85
430	...	-0'02	+0'00	+0'00	...	-0'02	...	0'95
440	...	+0'02	-0'01	+0'00	...	+0'05	...	1'05

The values in the second column representing the logarithm of the energy of the solar light, while those in the last one represent the energy of sunlight itself. Thus in the case of α Orionis, the energy for the wave-length 390 is represented by -0'57, sunlight being 0'55. The absolute energy is found "by adding the tabular number to that given for sunlight in the second column," so that we have -0'26 - 0'57 = -0'83, corresponding to a ratio of 0'15. Thus the energy of the light of α Orionis of wave-length 390 is only about one-seventh of that of wave-length 434.

In this number, also, Mr. Truman Safford contributes a paper on the observation of North Polar stars in the vertical of Polaris. After mentioning the difficulty of observing polars in the daytime, of connecting other polars with double transits of Polaris, and of the independence that now exists in the various Polar catalogues, he describes a method which tends to eliminate many of these deficiencies. It consists in adjusting a transit so that Polaris will be near its centre wire at eastern elongation, which takes place about 19h. 23m. sidereal time, and the two stars Camelopardalis 25 H and Schwed 1172 (Carrington 2965), which pass the same vertical within about half an hour of this time, the latter above Pole, earlier than the Pole-star reaches

the elongation, the former, below Pole, later. In this way the right ascension of Polaris plays a small part in its azimuth of elongation, which is dependent solely on the declination and latitude. Assuming the present declinations of the two stars mentioned, with probable errors of  $\pm 0''.2$  and  $\pm 0''.3$  respectively, he finds that the right ascension would probably be in error by  $\pm 0''.0025$ . and  $\pm 0''.0045$ . In fact, the probable errors "dependent upon anything but the transit of the star to be determined will be much less if the present method is used (with an equal instrument), than if stars in the same declination, but opposite Polaris in right ascension, were observed by direct comparisons in the meridian." By applying this method to other stars of different right ascensions and "gradually increasing declinations," as the R.A. of Polaris or its opposite is approached, numerous co-ordinates thoroughly independent can be obtained, and will "provide zero points for the proposed number of photographic plates  $2^2$  square, and consequently help to settle the places of all stars in that region."

MEASUREMENT OF JUPITER'S SATELLITES BY INTERFERENCE.

It has long been known that even in a telescope which is theoretically perfect, the image of a luminous point is composed of a series of concentric circles with a bright patch of light at the common centre. This system of circles can easily be observed by examining any bright star with a telescope provided with a circular diaphragm which diminishes the effective aperture. The appearance of the image is shown in Fig. 1, a. In the case of an object of finite angular magnitude the image could be constructed by drawing a system of such rings about every point in the geometrical image. The result for a small disk (corresponding to the appearance of one of the satellites of Jupiter as seen with a 12-inch telescope whose effective aperture

$\frac{r}{y} \propto \alpha$

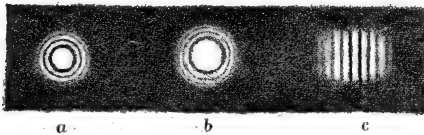

has been reduced to six inches) is given in Fig. 1, b; the chief points of difference between this and Fig. 1, a, being the greater size of the bright central disk, and the lesser clearness of the surrounding rings. The larger the disk the more nearly will the appearance of the image correspond to that of the object; and the smaller the object the more nearly does it correspond with Fig. 1, a, and the more difficult will be the measurement of its actual size. Thus, in the case just cited, the actual angular diameter is about one second of arc, and the uncertainty may amount to half this value or even more.

The relative uncertainty, other things being equal, will be less in proportion to the increase in the aperture, so that with the 36-inch telescope the measurement of the diameters of Jupiter's satellites should be accurate to within ten per cent. under favourable conditions.

It is important to note that in all such measurements the image observed is a diffraction phenomenon—the rings being interference fringes, and the settings being made on the position of that part of a fringe which is most easily identified. But such measurements must vary with the atmospheric conditions and especially with the observer—for no two observers will agree upon the exact part of the fringe to be measured, and the uncertainties are exaggerated when the fringes are disturbed by atmospheric tremors.

If, now, it be possible to find a relation between the size of the object and the clearness of the interference fringes, an independent method of measuring such minute objects will be furnished; and it is the purpose of this paper to show that such a method is not only feasible, but in all probability gives results far more accurate than micrometric measurements of the image.

In a paper on the "Application of Interference Methods to Astronomical Measurements" an arrangement was described

for producing such fringes, by providing the cap of the objective with two parallel slits, adjustable in width and distance apart. If such a combination be focussed on a star, then, instead of the concentric rings before mentioned, there will be a series of straight equidistant bands whose length is parallel with the slits, the central one being brightest,<sup>1</sup> Fig. 1, c.

The general theory of these fringes may be found in the *Philosophical Magazine* for March 1891. The general equation showing the relation between the visibility of the fringes and the distance between the slits is:

$$V^2 = \frac{\left[ \int \phi(x) \cos kx dx \right]^2 + \left[ \int \phi(x) \sin kx dx \right]^2}{\left[ \int \phi(x) dx \right]^2} \quad (1)$$

which reduces to the simpler form

$$V = \frac{\int \phi(x) \cos kx dx}{\int \phi(x) dx} \quad (2)$$

when the object viewed is symmetrical.

A number of applications of this formula are discussed in the former paper, but for the present purpose attention will be confined to the case in which the object viewed (or rather its projection) is a circular disk, uniformly illuminated.

In this case equation (2) becomes

$$V = \int_0^1 \sqrt{1 - \omega^2} \cdot \cos \pi \frac{\alpha}{\alpha_0} \omega \cdot d\omega \quad (3)$$

in which  $\alpha$  is the angular diameter of the object, and  $\alpha_0$  is the smallest angle resolvable by an equivalent aperture; that is, the ratio of a light-wave to the distance between the slits.

The curve expressing this relation is given in Fig. 2, in which the ordinates are values of the visibility of the fringes, and the abscissae are the corresponding values of the  $\alpha/\alpha_0$ .

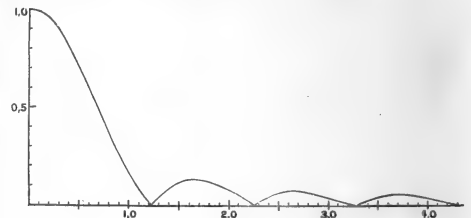

FIG. 2.

From this it will appear that the fringes disappear at recurring intervals, and in a laboratory experiment as many as four such disappearances were noted, and the average error in the resulting value of  $\alpha$ , the angular magnitude of the disk, was found to be less than two per cent.

From the curve it is evident that the first disappearance is most readily and accurately observed, and for this we have

$$\frac{\alpha}{\alpha_0} = 1.22;$$

whence, putting  $s$  for the distance between the centres of the slits, and taking for the wave-length of the brightest part of the spectrum  $0.0005$  mm.,<sup>2</sup> and dividing by the value of a second in radians we have

$$\alpha = \frac{1.38}{s} \quad (4)$$

In consequence of the kind invitation extended by Prof. Holden, it was decided to make a practical test of the usefulness of the proposed method at Mount Hamilton.

<sup>1</sup> These will be superposed on another set of fringes due to diffraction from the edges of the slits; but the latter are too faint and broad to cause any confusion.

<sup>2</sup> The wave-length will, of course, vary somewhat with the object observed, but may be made constant by interposing a red glass.

<sup>1</sup> *Philosophical Magazine*, July 1890.

For the preliminary experiments which are to be described it was thought desirable to use the 12-inch equatorial. Accordingly, a cap, provided with two adjustable slits, was fitted over the objective, and provided with a rod by means of which the distance between the slits could be altered gradually and at will by the observer, while the distance was measured on a millimetre scale attached to the sliding jaws. This arrangement, which was constructed under the supervision of Mr. F. L. O. Wadsworth, of Clark University, is shown in the accompanying diagram, Fig. 3.

Fig 3

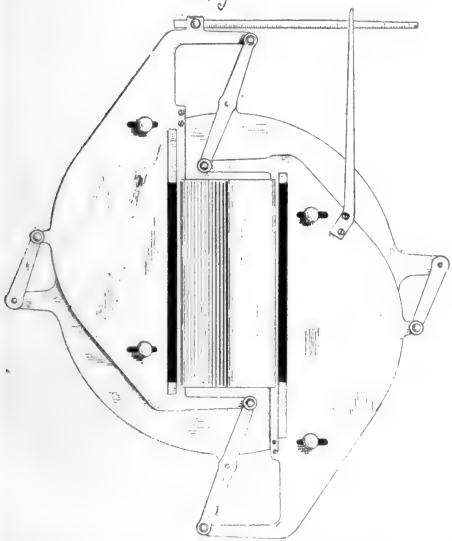

With this apparatus the satellites of Jupiter were measured, with results as given in the following table :-

TABLE I.

No. of Satellites.	I.	II.	III.	IV.	Seeing.
August 2 ...	1'29	1'19	1'88	1'68	Poor.
August 3 ...	1'29	—	1'59	1'68	Poor.
August 6 ...	1'30	1'21	1'69	1'56	Poor.
August 7 ...	1'30	1'18	1'77	1'71	Good.
Mean...	1'29	1'19	1'73	1'66	

These are the values of the angular diameters of the satellites of Jupiter as seen from the earth. To reduce these to Jupiter's mean distance these values are to be multiplied by 0.79, which gives for the final values—

I.	II.	III.	IV.
1"02	0"94	1"37	1"31

For the sake of comparison these values are recorded in the following table, together with those given by Engelmann, Struve, and Hough, and the last column contains some results kindly furnished by Prof. Burnham with the 36-inch on the same date (August 7) as the last of the series by A. A. M. :-

TABLE II.

No. of Satellite.	A. A. M.	ENG.	ST.	HO.	BU.
I...	1'02	1'08	1'02	1'11	1'11
II...	0'94	0'91	0'91	0'98	1'00
III...	1'37	1'54	1'49	1'78	1'78
IV...	1'31	1'28	1'27	1'46	1'61

It was found impossible to see the reappearance of the fringes on increasing the distance, yet the results of Table I. show that

the disappearance could still be sharply marked. Indeed the concordance of the observations made under different circumstances on different nights was even closer than was expected. With a larger telescope both the brightness of the fringes and their distance apart will be increased, and it may be confidently predicted that the accuracy will then be even greater.

The values given in the second column, "Engelmann," are probably more reliable than the succeeding ones, but it is well worth noting that the results obtained by interference agree with the others quite as well as these agree with each other.

It should also be noted that the distance between the slits was about four inches. It may therefore be stated that for such measurements as have just been described, a telescope sufficiently large to admit a separation of four inches—say a six-inch—suitably provided with adjustable slits is fully equal to the largest telescopes now used without them.

It is hoped that within a few months the 36-inch equatorial will be supplied with a similar apparatus and observations begun for the definite measurement of the satellites of Jupiter and Saturn and such of the asteroids as may come within the range of the instrument.

In concluding, I wish to take this opportunity of expressing my appreciation of the courtesy of Director Holden in placing all the facilities of the Observatory at my disposal, and of the hearty co-operation of all the astronomers of the Observatory, especially the valuable assistance of Prof. W. W. Campbell in making the observations.

Mount Hamilton.

A. A. MICHELSON.

THE SAMOAN CYCLONE OF MARCH 16, 1889.

THE Samoan hurricane of March 16, 1889, is one of those historic storms that have been rendered for ever memorable by the episodes of disaster and gallantry that attended them; by the escape of H.M.S. *Calliope*, which forced her way out of Apia harbour in the teeth of the hurricane, amid the cheers of the brave American sailors, who, themselves face to face with imminent death, forgot for a moment their own dire peril in their admiration of the daring and successful act of seamanship that rescued their more fortunate brothers. Mr. Everard Hayden, of the U.S. Hydrographic Office, has lately issued a preliminary Report on this storm, which, despite the regrettable meagreness of the data at his command, has, nevertheless, a certain scientific interest, inasmuch as less is known of the cyclones of the Pacific than of those of most other tropical seas.

The Apia storm, like the cyclones of the South Indian Ocean, was evidently formed on the northern limits of the south-east trades, and was one of a series that were generated in this region in March 1889. The first of these, in Mr. Hayden's opinion, appears to have originated on the 5th of the month, some 500 miles north-north-east from the Samoan Islands, and to have travelled first in a south-westerly direction, recurring in the latitude of these islands, but at 150 to 200 miles to the west of them, after which it took a south-eastward course between Tonga and Niue. It seems to have been a storm of great severity, and its passage was felt at Apia on the 6th and 7th, though not with any great intensity. It was succeeded by the cyclone that forms the principal subject of Mr. Hayden's Report. This, he thinks, was formed about March 13, some 300 miles to the north-east of the Samoan Islands, and on the 15th its centre passed either directly over, or a little to the north of, Apia harbour, moving, therefore, on a south-west course. He considers that it then sharply recurved, and that, with greatly increased strength, it passed a second time over Apia on the 16th, the day of the great naval disaster. The chief facts which led Mr. Hayden to this conclusion are those observed at Apia itself, for no positive evidence is forthcoming from the supposed birthplace of the storm, and only one ship reports the state of the weather anywhere to the north of Samoa. The peculiar feature of the Apia observations is, that the barometer fell steadily from the 12th to the afternoon of the 15th (about 0.7 inch), then rose (about 0.25 inch) during the latter part of that day, and then again fell on the 16th to a reading slightly lower than that of the previous day. On the 15th, squalls of moderate force (wind southerly, force 2 to 6) were experienced, and in the after part of the day, as the barometer rose, the direction changed from south to north and east. There had been no heavy sea, and it was thought that the gale was over. At midnight, however, the barometer began

falling again, the wind had increased, and the sea was high. The barometer continued falling, and the gale rapidly developed its full strength. From early morning of the 16th, for nearly twenty-four hours, it blew a hurricane, and the catastrophes commenced with the loss of the *Eber*.

Any attempted interpretation of facts so meagre must necessarily be in a great measure speculative. We have given that of Mr. Hayden, and others have been suggested. One, that of Lieutenant Witzel, is to the effect that the storm of the 16th was distinct from that of the previous day, and originated over Savaii (the island to the west of Upolu, in which is the harbour of Apia). Another, by Mr. Dutton, is that the storm of the 15th, after approaching the Samoan Islands on a south-west track, recurved to west and north-west, and during the following night again recurved sharply, describing a loop north of Savaii, and then returning towards Upolu, whence it moved southwards and south eastwards. Our own interpretation is somewhat different from any of these, and seems to be more in accordance with the habits of tropical cyclones, the movements of which are by no means so erratic as that implied by Mr. Dutton's hypothesis, while it does not involve the extremely and, we think, improbably sharp recurvature suggested by Mr. Hayden, nor the equally improbable generation of a second vortex only one day in the rear of the storm of the 15th, as supposed by Lieutenant Witzel. None of these explanations seem to take account of the circumstances that attend the formation of tropical cyclones, which, as we have elsewhere pointed out, differ in many respects from the storms of the temperate zone.

It is evident from [the considerable and steady fall of the barometer at Apia from March 12 to 15, that the Samoan Islands lay within the area of disturbance in which the storm was generated, and that the formation of the vortex was simply the concentration of this disturbance, which probably took place nearer to Apia than is supposed by Mr. Hayden, but still at such a distance that the first effect of the concentration—viz. a slight rise of the barometer in the area immediately around, and especially on the polar side—was felt at the Samoan Islands. If, then, as seems probable, the vortex was not formed until the afternoon of the 15th, this, in conjunction with the ordinary diurnal rise between 4 and 10 p.m., would account for the slight rise observed at Apia on the latter part of that day, and only the second fall to a minimum on the 16th was due to the actual passage of the cyclone. From the severity of the storm, as felt at Apia harbour, it is clear that Upolu must have been traversed by at least a portion of the inner vortex, but it could hardly have been very close to the centre, seeing that the barometer never fell to 29 inches; and therefore the long duration of the hurricane (24 hours) can only be explained by the very slow rate at which the storm was then travelling. This slow rate of progression strengthens the probability that it had not proceeded far from its birthplace, since, as a rule, tropical cyclones move forward slowly at first, and only gradually acquire greater speed of translation. It also strengthens the inference that it had originated not very far to the north or north-east of Upolu.

This explanation, as already remarked, can only be regarded as tentative, but it seems at least worthy of consideration by those who may have fuller data at hand. H. F. B.

### UNIVERSITY AND EDUCATIONAL INTELLIGENCE.

CAMBRIDGE.—The Sheepshanks Astronomical Exhibition has been awarded to P. H. Cowell, Scholar of Trinity College.

A memorial signed by 107 members of the Senate is published by the Vice-Chancellor: it expresses the opinion that "the whole question of degrees in science should be considered by the University." Among the signatures are some of those who took the Greek as well as some who took the anti-Greek side in the recent controversy.

In view of the fall in the aggregate of the Colleges the Council of the Senate propose to obtain powers for deferring the next increment of the College contribution to the University from 1893 to 1895, and the following increment (from £25,000 to £30,000) for seven years further—namely, to 1903.

Sir George Gabriel Stokes and Prof. Macalister, M.D., are among the delegates appointed to represent the University at the Dublin Tercentenary Festival next year.

Mr. E. W. Hobson, of Christ's College, is approved as Deputy

NO. 1155, VOL. 45]

for the Lowndean Professor of Astronomy for the Lent and Easter Terms.

We regret to hear that Prof. Adams's health does not yet allow him to resume his duties.

### SOCIETIES AND ACADEMIES.

LONDON.

Royal Society, November 19.—"The Thermal Emissivity of Thin Wires in Air." By W. E. Ayrton, F.R.S., and H. Kilgour.

In 1884 it was observed experimentally that whereas the electric current required to maintain a *thick* wire of given material, under given conditions, at a given temperature was approximately proportional to the diameter of the wire raised to the power three halves, the current was more nearly proportional to the first power of the diameter if the wire were *thin*. When this difference in the behaviour of a thick and thin wire was first noticed, it was regarded as being quite unexpected. But, as pointed out by one of us in the course of a discussion at a meeting of the Royal Society, the unexpected character of the result was due to people having assumed that the loss of heat from radiation and convection per square centimetre of surface per 1° excess temperature was a constant, and independent of the size and shape of the cooling body.

The very valuable investigations that have been made on emissivity by Mr. Macfarlane, Prof. Tait, Mr. Crookes, Mr. J. T. Bottomley, and by Mr. Schleiermacher, had for their object the determination of the variation of the emissivity with changes of the surface and with change in the density of the gas surrounding the cooling body, but it was not part of these investigations to determine the change in the emissivity that is produced by change in the shape and size of the cooling body. Indeed, so little has been the attention devoted to the very large change that can be brought about in the value of the emissivity by simply changing the dimensions of the cooling body, that in Prof. Everett's very valuable book of "Units and Physical Constants" the absolute results obtained by Mr. Macfarlane are given as the "results of experiments on the loss of heat from blackened and polished copper in air at atmospheric pressure," and no reference is made either to the shape or to the size of the cooling body.

[November 19, 1891.—Since this paper was sent in to the Royal Society a new edition of this book has appeared, and, in consequence of a suggestion made to Prof. Everett, the word "balls" has been added after the word "copper" in this new edition, as well as the following paragraph:—

"Influence of Size.—According to Prof. Ayrton, who quotes a table in 'Box on Heat,' the coefficient of emission increases as the size of the emitting body diminishes, and for a blackened sphere of radius  $r$  centims. may be stated

$$.004928 + \frac{.0003609}{r}$$

The value of  $r$  in Macfarlane's experiments was 2."]

The laws which govern the loss of heat from very thin cylindrical conductors have not only considerable scientific interest in showing how the shape of a body affects the convection currents, but they are of especial importance to the electrical engineer in connection with glow lamps, hot-wire voltmeters, fuses, &c. We therefore thought it desirable to ascertain the way in which the law of cooling for thick wires, which involved the diameter raised to the power three halves, passed into the law for the cooling of thin wires, involving only the first power of the diameter. For this object, the investigation described in the paper was commenced at the beginning of 1888, and the emissivity was measured of nine platinum wires, having the diameters of 1.2, 2.0, 2.9, 4.0, 6.0, 8.1, 9.3, 11.1, and 14 mils, or thousandths of an inch.

Suspecting that some of the published results on the currents required to fuse wires had been much influenced by the cooling action of the blocks to which the ends of the wires were attached, we started by making a calculation of the length necessary to give to our wires, so that the loss of heat by conduction should not introduce any important error into the determination of the emissivity. To do this it was necessary to calculate the distribution of temperature along a wire through which a steady current was flowing, and from which heat was lost by radiation,

convection, and conduction, and it was further necessary to improve on the calculation one of us had published on this subject in the *Electrician* for 1879, by taking into account the fact that the emissivity, as well as the thermal and electric conducting power, of the wire differed at different points in consequence of the difference of temperature.

Until we had completed the experiments described in this paper, we could, of course, only employ in this calculation values that we had guessed at as being something near the truth for the emissivity of platinum wire for different diameters and at different temperatures. Hence, after the completion of the experiments, we took up the mathematical investigation again, substituting for the emissivity such a function of the diameter of the wire and the temperature of the point as we had experimentally found it to be. Section IV. of the paper contains the investigation by which we finally arrived at the calculated distribution of temperature along the wire, and we have to express our sincere thanks to Prof. Henrici (whom we consulted as to the best method of practically solving the rather complex differential equation arrived at) for the warm interest that he has taken in the mathematical treatment of the subject, and for the many suggestions which he has made, and which have enabled us to arrive at the mathematical solution given in the paper.

Each wire to be tested was stretched along the axis of a horizontal water-jacketed cylinder 32½ cm. long, 7.62 cm. external and 5.8 cm. internal diameter, the inner surface of which was blackened and kept at a constant temperature by a stream of cold water flowing through the jacket. The rate at which heat was lost by any one of the wires was measured by the product of the current passing through it into the P.D. (potential difference) maintained between its ends, while the ratio of the P.D. to the current gave the resistance of the wire, and, therefore, its temperature. Experiments were in this way made with various currents flowing through each of the nine wires.

As the variation of resistance with temperature is known to vary with different specimens of platinum, experiments were separately made to determine the actual law of variation of resistance with temperature up to 300° C. for each piece of wire that had been employed in the emissivity experiments.

In this later determination various thermometers were used, and the subsequent comparison of these thermometers with a Kew standard thermometer involved a vast amount of labour, from the fact that it is, or at any rate was not possible three years ago, to purchase from the Kew Observatory a standard thermometer reading from, say, 200° to 300° C., with a short, wide chamber at the base in which the mercury expanded below 200° C. All that could be obtained was a long thermometer which had been carefully tested between 0° and 100° C., and the

remainder of whose tube had been simply calibrated for uniformity of bore. The consequence was that when we desired to compare one of our thermometers reading, say, from 200° to 300° C., with the Kew standard, their bulbs were very far apart when both were immersed in the oil-bath, and with the tops of the mercury columns just above the surface of the oil. A short description is given in the paper of the devices employed to overcome this difficulty, and which enabled an accurate comparison to be made between the thermometers.

On examining the curves, accompanying the complete paper, which show the emissivity for each temperature for each of the nine wires, we see that—

(1) For any given temperature the emissivity is the higher the finer the wire.

(2) For each wire the emissivity increases with the temperature, and the rate of increase is the greater the finer the wire. For the finest wire the rate of increase of emissivity with temperature is very striking.

(3) Hence the effect of surface on the total loss of heat (by radiation and convection) per second, per square centimetre, per 1° C. excess temperature, increases as the temperature rises.

On comparing the loss of heat from the wire of 1.2 mils diameter when at 300° C. with that from the wire of 6 mils diameter when at 15° C., both being in an inclosure at 10° C., we see that the former loses per square centimetre of surface per second not

$$\frac{300 - 10}{15 - 10}, \text{ or } 58 \text{ times}$$

as much heat as the latter, as it would if the emissivity were the same; but, instead,

$$60 \times 58, \text{ or } 3840 \text{ times}$$

as much heat; arising from the fact that the emissivity—that is, the number of calories (gramme C.) lost per second, per square centimetre of surface, per 1° C. excess temperature—of the 1.2 mil wire at 300° C. is 60 times as great as that of the 6 mil wire at 15° C. the emissivity of the latter wire varying very rapidly near 15° C.

From the curves which accompany the complete paper, each curve giving the variation of emissivity with temperature for a particular wire, the following table has been drawn up, giving the emissivities of the various wires at eight useful temperatures, and it will be observed that, in consequence of our investigation having been made on wires of which the thickest was thinner than the thinnest ever previously used in absolute determinations of emissivity, the emissivities we have experimentally obtained are far greater than any previously arrived at.

Diameter of wire in		Emissivities.							
Mils.	Millimetres.	40° C.	60° C.	80° C.	100° C.	150° C.	200° C.	250° C.	300° C.
1.2	0.0305	0.008230	0.009560	0.010300	0.010846	0.011875	0.012783	0.013625	0.014400
2.0	0.0508	0.005950	0.005860	0.007500	0.007900	0.008600	0.009070	0.009480	0.009850
2.9	0.0737	0.002193	0.003336	0.004086	0.004552	0.005095	0.005379	0.005628	0.005845
6.0	0.1524	0.002460	0.002660	0.002806	0.002930	0.003212	0.003460	0.003666	0.003837
8.1	0.2057	—	—	—	0.002854	0.002939	0.003076	0.003177	0.003352
9.3	0.2362	—	—	—	0.002297	0.002448	0.002586	0.002718	0.002843
11.1	0.2819	—	—	—	0.002053	0.002216	0.002363	0.002490	0.002608
14.0	0.3556	—	—	—	0.001894	0.002027	0.002136	0.002224	0.002286

The wire of 4 mils diameter is omitted from the table, as the experiments showed that its specific resistance was much greater, its temperature coefficient much smaller, and its emissivity much smaller than if it had been of platinum. This piece of wire probably, therefore, contained iridium or silver.

We find that the emissivity of thin platinum wires of different diameters at the same temperature can be very fairly expressed by a constant plus a constant into the reciprocal of the diameter of the wire. For example, we find that

$$\text{At } 100^\circ \text{ C. } e = 0.0010360 + 0.0120776d^{-1}, \dots (1)$$

$$\text{,, } 200 \text{ ,, } e = 0.0011113 + 0.0143028d^{-1}, \dots (2)$$

$$\text{,, } 300 \text{ ,, } e = 0.0011353 + 0.016084d^{-1}, \dots (3)$$

where  $d$  is the diameter of the wire in mils, or thousandths of an inch.

The statement, not unfrequently made, that the current required to maintain a wire of a given material at a given

temperature above that of the surrounding envelope is proportional to the diameter of the wire raised to the power three halves, is equivalent to stating that the emissivity is independent of the diameter. Now from the three formulæ (1), (2), (3), given above for  $e$ , we may conclude—

That for a temperature of 100° C. the value of  $d$  in the formula

$$e = 0.0010360 + 0.0120776d^{-1}$$

must be something like 220 mils, or 5.6 mm., in order that the neglect of the second term may not make an error in  $e$  of more than 5 per cent., and something like 1.15 inch, or 29.3 mm., if the error is not to exceed 1 per cent.

That for a temperature of 200° C. the value of  $d$  in the formula

$$e = 0\cdot0011113 + 0\cdot0143028d^{-1}$$

must be something like 244 mils, or 6·2 mm., in order that the neglect of the second term may not make an error in  $e$  of more than 5 per cent., and something like 1·28 inches, or 32·5 mm., if the error is not to exceed 1 per cent.

And that for a temperature of 300° C. the value of  $d$  in the formula

$$e = 0\cdot0011353 + 0\cdot016084d^{-1}$$

must be something like 267 mils, or 6·8 mm., in order that the neglect of the second term may not make an error in  $e$  of more than 5 per cent., and something like 1·39 inches, or 35·3 mm., if the error is not to exceed 1 per cent.

Generally, then, we may conclude that to assume that the emissivity is a constant for wires whose diameters vary from a small value up to 1 inch is to make a large error in the case of the greater number of the wires, and an error of hundreds per cent. in the case of some of them.

Using the formula (3) which we have arrived at for determining the emissivity of platinum wires of different diameters at 300° C., it follows that to maintain a platinum wire 0·75 mil in diameter at 300° C. would require a current density of 331,000 amperes per square inch; and, if the emissivity of a copper wire of the same diameter and at the same temperature may be taken as being the same, it follows that to maintain a copper wire 0·75 mil in diameter at 300° C. would require a current density of 790,000 amperes per square inch.

November 26.—“A New Mode of Respiration in the Myriapoda.” By F. G. Sinclair (formerly F. G. Heathcote), M.A., Fellow of the Cambridge Philosophical Society.

The Scutigerae respire by means of a series of organs arranged in the middle dorsal line at the posterior edge of every dorsal scale except the last.

Each organ consists of a slit bounded by four curved ridges, two at the edges of the slit, and two external to the latter. The slit leads into an air sac. From the sac a number of tubes are given off; these tubes are arranged in two semicircular masses. The ends of the tubes project into the pericardium in such a manner that the ends are bathed in the blood and aerate it just before it is returned into the heart by means of the ostia. In the living animal the blood can be seen through the transparent chitin of the dorsal surface surrounding the ends of the tubes; and in the organ and surrounding tissues cut out of a Scutigera directly it is killed the blood corpuscles can be seen clustering round the tube ends. If the mass of tubes of a freshly killed specimen are teased out under the microscope in glycerine, they can be seen to be filled with air. The tubes each branch several times. Each tube is lined with chitin, which is a continuation of the chitin of the exo-skeleton. Each tube is also clothed with cells, which are a continuation of the hypodermis. The tubes end in a blunt point of very delicate chitin.

I therefore hold that the respiratory organ in Scutigera holds a position intermediate between the tracheæ of Myriapods and the lungs of Spiders. I hold with A. Leuckart (*Zeitsch. für Wiss. Zool.*, vol. 1. p. 246, 1849, “Ueber den Bau und Bedeutung der sog. Lungen bei den Arachniden”) that the tracheæ have developed into the lungs of Spiders and Scorpions, and I think that the organs in question form a series of which the lowest term are the tracheæ, the next the organ of Scutigera, then the lungs of Spiders, and then of Scorpions.

Zoological Society, November 17.—Dr. A. Günther, F.R.S., Vice-President, in the chair.—The Secretary read a report on the additions that had been made to the Society's Menagerie during the month of October 1891, and called special attention to the following: a young Buffon's Skua (*Stercorarius parasiticus*), captured near Christchurch, Hampshire, and presented by Mr. E. Hart, and a Land-Crab (*Geocarcinus ruricola*) from the island of Fernando de Noronha, brought home and presented by Mr. D. Wilson-Barker.—The Secretary read a letter from Dr. G. Martorelli, of Milan, inclosing a coloured drawing of both sexes of a hybrid Duck bred in the public Garden of Milan, between *Branta rutina* ♂ and *Anas boschas* ♀.—Mr. G. A. Boulenger gave an account of the various forms of the Tadpoles of the European Batrachians, and a statement of the characters by which the different species may be distinguished in this stage of their existence.—A communication was read from

Mr. Edgar A. Smith, containing descriptions of new species of Shells from New South Wales, New Guinea, and the Caroline and Solomon Islands, based on specimens lately presented to the British Museum by Mr. John Brazier, of Sydney.—Lord Walsingham gave an account of the Microlepidoptera of the West Indies, based primarily on the collections made in St. Vincent and other islands by Mr. H. H. Smith, under the direction of the joint Committee of the British Association and the Royal Society for the exploration of the Lesser Antilles.—A communication was read from M. E. Simon containing the first portion of an account of the Spiders of the island of St. Vincent, based on specimens obtained under the direction of the same Committee.—A communication was read from Mr. H. Nevill, urging the importance of founding an experimental Zoological Station in the tropics, and advocating the claims of Trincomalee in Ceylon for such an institution.—Dr. Johnson Symington read a paper on the nose, the organ of Jacobson, and the dumb-bell shaped bone in the *Ornithorhynchus*.—Mr. A. Smith-Woodward read a paper on a Mammalian tooth from the Wealden formation of Hastings, being the first trace of a Cretaceous Mammal discovered in Europe. This remarkable fossil the author was inclined to refer provisionally to the genus *Plagiaulax* of the Purbeck Beds, and to call it *Plagiaulax dawsoni*, after its discoverer.—A communication was received from Mr. C. Davies Sherborne, giving an exact account of the dates of issue of the parts, plates, and text of Schreber's “Säugethiere.” Great difficulties in synonymy had arisen from previously imperfect knowledge of these dates.

December 1.—Mr. Henry Seebohm in the chair.—Mr. Sclater exhibited a specimen of a Shearwater obtained near Sydney, and brought from Australia by Prof. Anderson Stuart. This specimen had been determined by Mr. Salvin to belong to *Puffinus gavia*, a New Zealand species not hitherto known to occur in Australia.—Mr. Seebohm exhibited and made remarks on specimens of several very interesting birds recently obtained in Ireland. Amongst these was an example of the Yellow-browed Warbler (*Phylloscopus superciliosus*) obtained on the Teatragh Rock, the most westerly station in Europe.—Dr. E. Hamilton exhibited a specimen of the Red-breasted Snipe of North America (*Macrorhamphus griseus*), obtained in Scotland.—Mr. W. B. Tegetmeier exhibited some specimens illustrative of the abnormal form of the bill in birds caused by injuries to that organ during life.—Mr. G. A. Boulenger read some notes on specimens of Reptiles from Transcaspia recently received by the British Museum, and pointed out that examples of several well-known Indian species occurred in this collection.—A communication was read from Miss E. M. Sharpe containing the second portion of her descriptions of new Butterflies from British East Africa, collected by Mr. F. J. Jackson during his recent expedition.—Mr. A. D. Michael read a paper upon the association which he had observed between certain Acarines of the family Gamasidae and certain species of Ants. The author came to the following conclusions: (1) that there is an association between some Gamasids and Ants; (2) that a species of Gamasid usually associates with one or two species of Ant preferentially; (3) that the Gamasids of Ants's-nests are not usually found elsewhere; (4) that the Gamasid abandons the nest if the Ant does; (5) that the Gamasids live upon friendly terms with the Ants; (6) that the Gamasids are not true parasites; (7) that they do not injure the Ants or their young; (8) that the Gamasids will eat dead Ants, and are probably either scavengers or messmates.—A communication was read from Mr. Edward Bartlett containing an account of the specimens of Rhinoceros from Borneo contained in the Museum of Sarawak.—A communication was read from Mr. T. T. Somerville, of Christiania, containing notes on the Lemming (*Myodes lemmus*).

Anthropological Institute, November 24.—E. W. Brabrook Vice-President, in the chair.—A paper on the perforated stones of South Africa, by H. Mitford Barber, was read.—An account of the Similkameen Indians of British Columbia, by Mrs. S. S. Allison, was read. The tribe at present inhabiting the upper valley of the Similkameen are immediately descended from a small band of the warlike Chilcotins, who established themselves in the upper valley of the river about a hundred and fifty years ago, and intermarried with the Spokans. They have much deteriorated, both physically and mentally, within the last twenty years, and are rapidly becoming extinct. The average stature of the men is about 5 feet 6 inches; their frames are lithe and muscular.

and their movements quick and graceful. Their complexion is very light, and they have small hands and feet. The colour of their hair varies from jet-black to red-brown, and in some cases it is almost curly. They are born horsemen and capital shots. The sharp horns of the mountain goat were formerly fixed on shafts of hard wood and used as spears both in hunting and warfare; stone knives and hatchets were also used. The summer dwellings of the Similkameen Indians were made of mats of cedar bark, manufactured by the Hope Indians, which were thrown over a circular frame of poles. The winter houses were simply pits dug in the ground and roofed with poles and earth. All sickness was supposed to be the work of an evil spirit, who fastened on a victim and hung on, drawing away his life, until charmed away by the doctor, who worked himself into a state of frenzy, singing and dancing while he was trying to lure the evil spirit from his patient. Many of the medicine-men exercise strong mesmeric power over their patients, and they use several herbs as medicines; their panacea for all ills, however, is the vapour-bath. When an Indian died he was laid out in state on a couch of skins; everything put on the body was new; his bow and arrows were laid at his side, along with his knife. His friends then assembled round him to feast, and when the feast was over his friends advanced, and taking his hand bade him farewell. Immediately after a funeral takes place the encampment is moved, lest the spirit of the deceased should revisit it. A widow or widower is forbidden to eat meat and certain vegetables for a month, and must wear quantities of spruce bush inside their shirts, next their skin. Cannibalism was never known among the Similkameens. In the mountain is a certain stone which is much venerated by the Indians, and it is said that striking it will produce rain. Polygamy was allowed, and if the husband and wife tired of each other, the price of the woman, or its equivalent, was returned by her father or guardian, and the parties were then free to contract another matrimonial alliance; but adultery, though it was generally compromised, was sometimes punished by cutting off the woman's nose or splitting her ears. Occasionally sick persons were buried before they were quite dead, and a good deal of infanticide was practised. The author has not found these Indians to be thieves, and gives them a general good character in other respects.

**Geological Society, November 25.**—Sir Archibald Geikie, F.R.S., President, in the chair.—The following communications were read:—On the os pubis of *Polacanthus Foxi*, by Prof. H. G. Seeley, F.R.S. Hitherto the evidence of the systematic position of *Polacanthus* has not been very precise. The author has detected the missing pubis as an isolated specimen. This he regards as the anterior portion of the left pubis, and appends a full description of the bone. He furthermore gives a critical account of our knowledge of other pelvic bones of the genus, and is led to associate *Agathaumas*, *Crataeosaurus*, *Omosaurus*, and *Polacanthus* in near alliance, in the Scelidosaurian division of the Order *Ornithischia*.—A comparison of the red rocks of the South Devon coast with those of the Midland and Western Counties, by Prof. Edward Hull, F.R.S. The author believes, with Dr. Irving, that the red rocks of Devonshire are representatives of the Permian and Trias which occupy so large a portion of the district bordering Wales and Salop, and which extend into the Midland Counties, and comments on the remarkable resemblance between the representative beds on either side of the dividing ridge of Palæozoic rocks which underlies East Anglia and emerges beneath the Jurassic strata in Somersetshire. He believes that the breccia forming the base of the series in the Torquay district is a representative of the Lower Permian division, but differs from Dr. Irving, in assigning the red sandstones and marls of Exmouth to the Trias, and not to the Permian as that author has done. He compares them with the Lower Red and Mottled Sandstones, and regards the Marls as of local origin, thus causing the beds to diverge from the normal type. The Budleigh Salterton Pebble-beds, with overlying sandstones and pebbly beds, he assigns to the horizon of the Pebble-beds of the Midland area, and points out that fossils of Silurian and Devonian types occur in the pebbles of both areas. The Upper Division of the Bunter is well shown at Sidmouth, and the author takes a calcareous breccia, two feet thick, which is found in the cliffs, as the basement-bed of the Keuper division.—Supplementary note to the paper on the "Red Rocks of the Devon Coast-section," Q.J.G.S., 1888, by the Rev. A. Irving. In this note the author accepts Prof. Hull's determination (see above) of the breccia at Sidmouth as the base

of the Keuper, and discusses the age of the sandstones containing vertebrate remains discovered by Messrs. Whitaker, Metcalfe, and Johnston-Lavis. He brings forward evidence in support of his view that these are really of Upper Bunter age, notwithstanding the character of the organisms. He adds new material in support of his contention that the sandstones and marls which Prof. Hull assigns to the Lower Bunter are really Permian; but he is inclined to think that the breccias (in part, at least) pass laterally into the sandstones, and do not underlie them. From this it follows that the break between the Permian and Trias of Devon is marked by the absence of the Lower Bunter of the Midlands, and the author quotes remarks of Mr. Ussher in support of his view that there is an unconformity at the base of the Pebble-bed. In conclusion the author refers to the difficulties of ascertaining the exact age of the breccias, and notes that we cannot prove that the highest Carboniferous beds are present in Devonshire. He observes that there is no valid reason why the great breccia-sandstone series of Devon should not be the true equivalent of the Lower Rothliegendes both in time and position in the sequence, and that some portions of them may be even older than the Rothliegendes of some districts. He discusses the evidence furnished by the igneous rocks, and points out the abnormal position both for the British and German areas which these would occupy, if the breccias were of Triassic age. The reading of this paper was followed by a discussion, in which Mr. H. B. Woodward, Mr. Hudleston, Mr. Topley, Prof. Boyd Dawkins, the President, Prof. Hull, and the author took part.

December 9.—Sir Archibald Geikie, F.R.S., President, in the chair.—The following communications were read:—On the rocks mapped as Cambrian in Caernarvonshire, by the Rev. J. F. Blake.—High-level Glacial gravels, Gloppe, Cynn-y-bwch, near Oswestry, by A. C. Nicholson (communicated by W. Shone). These gravels are found at Gloppe, and are situated at a height of from 900 to 1160 feet above sea-level, on the eastern slope of a ridge of Millstone Grit which forms the western border of the Cheshire and Shropshire plain. The beds present the appearance of having been abruptly cut off on the north-eastern slope. The gravels are in places much contorted, and false-bedding is frequent. They contain numerous striated erratics. Amongst the boulders are Silurian grits and argillites, granites like those of Eskdale, Crifell, &c., Carboniferous rocks, Lias shale, and Chalk flints. The shells are often broken, rolled, and striated, but the bulk of them are in fairly good condition. A list of the shells is given, including nine Arctic and Scandinavian forms not now living in British seas, nine northern types, also found in British seas, two southern types, and nearly fifty species of ordinary British forms. Comparative lists of the shells of Moel Tryfan and of those now living in Liverpool Bay are placed side by side with the list of shells from Gloppe. The reading of this paper was followed by a discussion, in which Dr. Hicks, Prof. Hull, Mr. Shone, Prof. Blake, the President, and the author took part. Some remarks sent by Mr. Clement Reid were read by the Secretary.—The Subterranean denudation of the Glacial Drift, a probable cause of submerged peat and forest-beds, by W. Shone.

**Royal Microscopical Society, November 30.**—*Conversazione*.—There was a numerous attendance at this meeting, which passed off very successfully. The following objects and instruments were exhibited:—*Megalotrocha alboflavicans*, by Mr. F. W. Andrew.—Foraminifera from the London Clay, by Rev. G. Bailey.—*Amphipleura pellucida*, *Arachnidiscus Ehrenbergi*, Polycystinae from Barbadoes, a microscope with new substage focussing arrangement, by Messrs. R. and J. Beck.—Foraminifera from the Chalk, by Mr. E. T. Browne.—Hyaline Foraminifera from the Folkestone Gault—viz. *Vitriuebbina Sollasi*, n. sp. (Chapman), *V. levis*, Sol., *Polymorphina Orbignii*, n. var. *ceriseicornis* (Chapman), by Mr. F. Chapman.—A thickened nodule of *Nitella translucens*, by Mr. E. Dadswell.—*Volvox* and *Batrachospermum* in saturated solution of common salt; diatom structure in medium (Br Ant<sub>1</sub>, Br Ar<sub>5</sub>, Piperine<sub>2</sub>), by Mr. J. E. Inngpen.—*Ptilaria sanguinis hominis* (*diurna* and *nocturna*), prepared by Dr. P. Manson; *Bacillus anthrax* in lung; microscopes with new focussing arrangement to substage, by Messrs. Johnson.—*Epistylis flavicans*, *Lophopus crystallinus*, *Argulus foliaceus*, by Mr. R. Macer.—Transverse section of fertile head of *Equisetum arvense* showing spores and elators in situ, section of *Ptila grandiflora* showing reticulate and pitted cells, by Mr. G. E. Mainland.—*Hoplophora carinata* v. *pul-*

*cherrina*, a South European mite, by Mr. A. D. Michael.—Photographs and drawings illustrating the absorption of the tubercle and other bacilli by the leucocytes, photographs of micro organisms in dental caries, by Mr. J. H. Mummary.—Exhibition of natural history objects with the projection microscope, monochromatic light apparatus for microscopic work, by Messrs. E. M. Nelson and C. L. Curties.—Phagocytes inclosing tubercle-efusion from dorsal lymph-sac of frog, by Mr. Pound.—*Cherryfield rhomboides* in balsam, with a new  $\frac{1}{2}$  apochromatic homogeneous immersion 1.4 N.A., by Messrs. Powell and Lealand.—A collection of different species of Rotifera, by Mr. C. Rousselet.—Photograph of a new apparatus for measuring drawings made with the camera lucida, by Sir Walter Selland, K.C.M.G.—Petrological slides, transparencies of rock sections, Foraminifera, &c., by Mr. G. F. Smith.—Starch from potato fruit under  $\frac{1}{4}$  inch, with polariscope, by Mr. W. T. Suffolk.—Photographs of *Potura* scales, by the Hon. J. G. Vereker.—Section of passion-flower, by Mr. J. J. Zezey.—Blight of grape vine (*Phylloxera*); *Bacillus mallei* (glanders); Pacinian corpuscles in mesentery of cat, chlorophyll of moss, Diatomaceæ from Jutland, a slide containing 100 species of *Pleurosigma*, by Messrs. Watson.

**Entomological Society, December 2.**—The Right Hon. Lord Walsingham, F.R.S., Vice-President, in the chair.—Dr. D. Sharp, F.R.S., exhibited and commented on a number of photographs of various species of *Lucania* belonging to M. René Oberthür.—Mr. C. G. Barrett exhibited specimens of local forms and varieties of Lepidoptera, taken by Mr. Percy Russ near Sligo, including *Pieris napi*, var. near *brionia*; *Anthocharis cardamines* (male), with the orange blotch edged with yellow, and yellowish forms of the female of the same species; very blue forms of *Polyommatus alus*; males of *P. alexis*, with the hind margin of the under wings spotted with black, and very handsome forms of the female.—The Rev. S. St. John exhibited two specimens of *Lycæna argiades*, taken in Somersetshire by Dr. Marsh in 1884; three specimens of *Deilephila euphorbia*, bred from larvae found feeding on *Euphorbia paralias* on the Cornish coast in September, 1889; and a series of various forms of *Anchoetis pistacina*, all taken in a garden at Arundel. Lord Walsingham, F.R.S., Mr. Barrett, and Mr. McLachlan, F.R.S., took part in the discussion which ensued.—Mr. Jenner-Weir exhibited and made remarks on two dark specimens of *Zygena minos* which had been caught in Carnarvonshire. He remarked that the specimens were not representatives of complete melanism, and suggested that the word "phæism"—from *φαῖος*, dusky—would be a correct word to apply to this and similar departures from the normal coloration of a species.—Mr. C. J. Gahan exhibited specimens of the common "book-looker," *Atropos pulsatoria*, Fabr., which he had heard making a ticking noise similar to that made by the "death-watch" (*Anobium*).—Mr. B. A. Bower exhibited the following rare species of Micro-Lepidoptera: *Spiloneota pauperana*, Fröl.; *Gelechia osseella*, Stn.; *Chrysoclista bimaculella*, Haw.; and *Elachista cingillella*, Fisch.—Mr. R. Adkin exhibited a variety of *Anthocharis cardamines*, and one specimen of *Sesia scolioformis* bred from a larva found at Rannoch.—Mr. G. T. Baker read a paper entitled "Notes on *Lycæna* (recte *Thecla*) *rhyminis*, *tengstræmii*, and *pretiosa*." A discussion followed, in which Lord Walsingham, Captain Elwes, and Mr. Baker took part.—Mr. F. Merrifield read a paper entitled "The effects of artificial temperature on the colouring of *Vanessa urtica* and certain other species of Lepidoptera." The author stated that both broods of all three species of *Selenia*, *Platypteryx falcata*, *Vanessa urtica*, *Bombyx quercus* and var. *calluna*, and *Chelonia caja* were affected by temperature in the pupal stage, the lower temperature generally producing the greater intensity and darkness of colour; some of the *Vanessa urtica* made a near approach to the var. *polaris* of Northern Europe. A long discussion ensued, in which Mr. E. B. Poulton, F.R.S., Prof. Meldola, F.R.S., Mr. Barrett, Mr. Jenner-Weir, and Lord Walsingham took part.—Mr. W. Bateson read a paper entitled "On the variation in the colour of the cocoons of *Eriogaster lanestris* and *Saturnia carпинi*," and exhibited a large number of specimens in illustration of the paper. Lord Walsingham congratulated Mr. Bateson on his paper, and on the intelligent care and method shown in his experiments, and said that he was glad to see that at Cambridge there was an entomologist ready to enter this interesting field of investigation, and perhaps at some future day to contest the palm with Mr. Poulton as re-

presenting the sister University of Oxford. He had noticed that the larvae of *S. carпинi*, if left in a box with dead food, and probably partially starved, made a light-coloured cocoon; but that when the cocoon was made under natural conditions, on living food-plants on the moors, it was of a dark colour. Mr. Poulton and Prof. Meldola continued the discussion.

**Linnean Society, December 3.**—Prof. Stewart, President, in the chair.—The President announced the recent bequest by the late Sir George MacLeay, K.C.M.G., of a marble bust by his father, the late Dr. William Sharp MacLeay, formerly a Fellow and Vice-President of the Society.—The President then exhibited a series of specimens of a South American beetle, showing the extremes of variation of colour observable within the limits of a single species.—Mr. J. E. Harting exhibited a photograph of an abnormally situated nest of the chimney swallow (*Hirundo rustica*), which had been built for the second time on a swinging hook in an outhouse; and made some remarks on three recorded cases of swallows nesting in trees, a most unusual habit.—The Botanical Secretary read a paper by Mr. W. West, on the Fresh-water Algae of the West of Ireland, and exhibited by way of illustration a number of preparations under the microscope, and a series of beautiful drawings by the author. The paper was criticized by Messrs. A. W. Bennett and E. M. Holmes, both of whom testified to the excellence of the work done and the value of the drawings.—The Zoological Secretary next read a paper by Dr. W. H. Strachan, on the tick pest of Jamaica, which was characterized as of so serious a nature as to demand investigation by entomologists, with a view to a remedy. An interesting discussion followed, in which Mr. D. Morris gave a variety of details from personal experience during a residence of some years in Jamaica, and Mr. A. D. Michael pointed out the generic characters of certain West Indian ticks which were likely to include those found in Jamaica by Dr. Strachan. The question of remedy for this plague was discussed by Dr. John Lowe, and Messrs. T. Christy, C. Breeze, and T. J. Briant.

## CAMBRIDGE.

**Philosophical Society, November 23.**—The following communications were made:—The self-induction of two parallel conductors, by Mr. H. M. Macdonald. The well-known expression for the self-induction of two parallel wires (Maxwell, § 685) holds only for the case when neither of them is magnetic. For the case when both wires are magnetic, the value of the coefficient is found, in this paper, in the form of an infinite series. This series can be expressed in finite terms when only one of the wires is magnetic, and then gives

$$L = \frac{1}{2}(\mu_1 + \mu_2) + 2\mu_0 \log \frac{b^2}{aa'} + 2\mu_0 \frac{\mu - \mu_0}{\mu + \mu_0} \log \frac{b^2}{b^2 - a^2}$$

where  $\mu_0$  is the permeability of the surrounding media (viz. usually unity),  $a$  the radius of the magnetic wire of permeability  $\mu$ ,  $a'$  the radius of the other wire, and  $b$  the distance between their lines of centres. The effect of the magnetic quality is exhibited by means of numerical tables.—The effect of flaws on the strength of materials, by Mr. J. Larmor.—The effect of an air-bubble of spherical or cylindrical form in increasing the strains in its neighbourhood was examined; and it was suggested that the results might be of practical service in drawing general conclusions as to the influence of local relaxations of stiffness of other kinds. In particular, a cavity of the form of a narrow circular cylinder, lying parallel to the axis of a shaft under torsion, will double the shear at a certain point of its circumference; and the effect of a spherical cavity will not usually be very different. It is assumed in the analysis that the distance of the cavity from the surface of the shaft is considerable compared with its diameter, so that the influence of that boundary may be left out of account in an approximate solution.—The contacts of certain systems of circles, by Mr. W. McP. Orr.—On liquid jets, by Mr. H. J. Sharpe. The problem is treated by the method of Fourier series.

## DUBLIN.

**Royal Society, November 18.**—Prof. A. C. Haddon, President of the Scientific Section, in the chair.—An analysis of the spectrum of sodium, by Dr. G. Johnstone Stoney, F.R.S. The position of the lines which present themselves in



the spectrum of hydrogen are given, or approximately given, by Balmer's law, viz.

$$n = k \left( 1 - \frac{4}{m^2} \right),$$

where  $k = 274 \cdot 263$ . In this formula  $n$  becomes the oscillation frequency of the successive lines, when for  $m$  we write the integer numbers 3, 4, 5, &c. Similarly, Profs. Kayser and Runge have found that A, B, and C can be determined so that the empirical formula,

$$n = A + B \frac{1}{m^2} + C \frac{1}{m^4},$$

shall approximately represent the positions of the lines in any one of the three series that present themselves in the spectra of the other light monad elements—Li, Na, K, Rb, Cs. These formulae have an important physical meaning. They indicate that  $n$  is a function of  $1/m$ ; in other words, that although the periodic times of the successive rays are not themselves a fundamental period with its harmonics, as is the case with the vibrations that give rise to musical sounds, they in some way depend on an event of this simple character which is going on in the molecules from which the spectrum emanates. Balmer's law may be represented by a very simple diagram which places this relationship in evidence. Draw the parabola

$$y^2 = \frac{1}{4k} (k - x),$$

and place its axis horizontal. Erect an ordinate at the distance  $k$  from the vertex. Double this out, and using its double length as unit, set off upon it the harmonics  $1/3, 1/4, 1/5, \&c.$  From each of the points so determined draw horizontal lines to the curve: these are the values of  $n$  for the successive lines of the hydrogen spectrum. Now, having regard to the fact that the light monad elements, H, Li, Na, K, Rb, Cs, have all of them series of lines which appear to belong to the same general type, we are justified in assuming that Balmer's law is the simplest case of a general law which prevails throughout all the light monads. Hence, if the oscillation-frequencies be plotted down as the horizontal lines of a diagram constructed as above with  $x = n$  and  $y = 1/m$ , the curve passing through the ends of the lines in the other monads should be some curve of which the parabola is a particular case. This may happen in different ways, but the simplest hypothesis is that they are hyperbolas or ellipses. Accordingly, the author has tried this hypothesis in the case of the sodium spectrum, with the result that hyperbolas approximately represent series P (the principal series) and series S (the series of sharp lines), and that a parabola represents the third series, series D (the series of diffuse lines); and with the further interesting result that the only line in the sodium spectrum which has not hitherto fallen into its place as a member of one or other of the three series proves to be in reality the first term of series S, with a value for  $n$  which is negative instead of positive. The physical meaning of this is that the revolution going on within the molecules round that elliptic partial which gives rise to this double line is in the opposite direction to what it would have been if its  $n$  had been positive (see memoir by the author "On Double Lines in Spectra," recently published in the Transactions of the Royal Dublin Society). The equation of an hyperbola being

$$(a - x)^2 = P(b + 1000 \cdot y)^2,$$

the values to be attributed to the constants for series P of the sodium spectrum are approximately—

$$\begin{aligned} \log P &= 3 \cdot 7740300 \\ a &= 3337 \cdot 4120 \\ b &= 1438 \cdot 35 \end{aligned}$$

and their values for series S are—

$$\begin{aligned} \log P &= 2 \cdot 5263843 \\ a &= 434 \cdot 0587 \\ b &= 108 \cdot 514. \end{aligned}$$

The equation of a parabola being

$$x = a - 1000 \cdot by^2,$$

the values of the constants for series D are—

$$\begin{aligned} a &= 244 \cdot 93, \\ \log b &= 0 \cdot 04357. \end{aligned}$$

The investigation shows that in series P and series S of the sodium spectrum, the curve of nature is not an exact hyperbola, but a curve slightly less curved in the neighbourhood of its vertex. It also indicates that there is probably a line in the sodium spectrum, belonging to series P, at or a little less than the wavelength 21130.—Mr. J. Joly exhibited and described a shutter for use in stellar photography. This shutter enables any bright star in the field of the telescope to be covered at will, so as to secure better definition. The shutter is a small watch-spring magnet, adjustable to any part of the field, and pivoted so that it can be rotated by the action of a current which circulates round the field in a narrow coil. In one position of the magnet the star is exposed, in the other covered. A modification for parallax work, suggested by Mr. A. A. Rambaut, and used at Dunsink Observatory, has the magnet and coil to one side of the field, and the shutter, which is carried on a needle attached to the magnet, fixed in the centre of the field. There is no vibration in these shutters, owing to the small mass of the moving parts. In the first form, the current in the one coil may control shutters placed in any part of the field of the telescope, so that, if desirable, more than one star may be covered.—Prof. T. Johnson described the structure and function of the peculiar swellings (callosities) of *Nitophyllum versicolor*, Harv., and pointed out the bearing of his observations on the specific character of *N. versicolor*, and Schmitz's views on the structure of the Floridean thallus.—Mr. E. W. L. Holt read a list of the rarer shore and deep-sea fishes obtained during the cruise of the s.s. *Harlequin* on the west coast of Ireland (1891). One fish, *Centrophorus squamosus* (Gm. L.), taken in deep water off the Mayo coast, is new to the British fauna. The following are new to the Irish fauna: *Raia oxyrhynchus* (Linn.), from 500 to 375 fathoms, and from shallow water; *Raia microcellata* (Mont.), from shallow water—coast of Mayo and Donegal; *Rhombus norvegicus* (Gthr.), from shallow water—Donegal Bay; *Arnoglossus grohmanni* (Bonap.) was again taken; *Crystallagobius nilsoni* (Düb. and Kor.) proved to be abundant everywhere, between 10 and 35 fathoms. The following were amongst the forms, usually inhabiting littoral water, which were taken at more than 100 fathoms: *Scyllium canicula*, *Acanthias vulgaris*, *Galeus vulgaris*, *Raia oxyrhynchus*, *Gadus aeglefinus*, *Conger vulgaris*.

PARIS.

Academy of Sciences, December 7.—M. Duchartre in the chair.—Reply to a note by M. Besson on phosphides of boron, by M. Henri Moissan. The author points out that he remarked upon the reaction between boron and phosphorus in a paper presented on April 6, 1891, and more fully described its properties on July 6, 1891. He therefore claims priority over M. Besson, who first presented a note on the subject on July 13.—On the theory of linear differential equations, by M. André Markoff.—On modifications of the adiabatic of a contracted gaseous stream, by M. H. Parenty.—The vapour tensions of cobalt chloride solutions, by M. Georges Charpy. The graphic representation of the tensions at different temperatures of a solution saturated in the cold (containing 32 per cent. of  $\text{CoCl}_2$ ) gives two right lines from  $20^\circ$  to  $40^\circ$ , and from  $75^\circ$  onwards respectively, joined by a curve. Each of these right lines corresponds to a definite state of hydration of the salt; the lower represents the tension of a red solution, the upper of a blue one. These results agree with those of M. Etard, but the interval of passage between the two states is from  $40^\circ$  to  $75^\circ$  instead of from  $35^\circ$  to  $50^\circ$ , as found by this observer, a difference explained by the use of saturated solutions in his experiments.—Action on some metals of solammonium and potassammonium, by M. Joannis. (See Notes.)—Calculation of the temperature of ebullition of isomeric ethers of the fatty acids, by M. G. Hinrichs.—Thermal data concerning active malic acid and potassium and sodium malates, by M. G. Massol. The heat of solution of the anhydrous acid is (per mol. in 4 litres),  $-3 \cdot 31$  Cal.; heats of neutralization—by  $\text{K} = +26 \cdot 23$  Cal., by  $\text{Na} = +24 \cdot 86$  Cal.; heats of solution of the anhydrous salts:

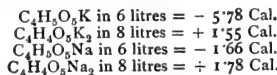

The heats of formation of the salts indicate that malic acid lies between succinic and oxalic acids in the energy of its action.—

The rotatory power of silk, by M. Léo Vignon.—Ammonia in atmospheric waters, by M. Albert Lévy. At the previous meeting of the Academy, MM. Marcano and Müntz gave the results of twenty estimations of ammonia in rain caught at Caracas, and the mean (1.55 mgr. per litre) was thought by M. Müntz to be higher than that obtained in our latitudes. M. Lévy, however, shows that a higher proportion has been frequently obtained in France and elsewhere. He has estimated the ammonia and nitric acid in all the rainfalls at Montsouris for sixteen years. The average number is 150 per year; and from these 2000 or 3000 measures, a mean weight of 2.2 mgr. of ammonia per litre has been obtained.—In which part of the nervo-muscular system is inhibition produced?, by M. N. Wedensky.—The antennal gland of Amphipods of the Orchestiidae family, by M. Jules Bonnier.—New list of large Cetacea stranded on the French coast, by MM. G. Ponchet and H. Beauregard.—On the parasitic fungus of *Lachnidium acidiorum*, Gd., by M. A. Girard.—On the germination of grains of *Araucaria Bidwilli*, Hook., and *Araucaria brasiliensis*, Rich., by M. Ed. Heckel.

## BERLIN.

Physiological Society, November 13.—Prof. du Bois Reymond, President, in the chair.—Prof. H. Munk gave an account of further experiments made in his laboratory, on the effect on the larynx of section of the superior laryngeal nerve in the horse, and which had again led as their result neither to paralysis nor atrophy of the laryngeal muscles.—Dr. Krüger having investigated the chemical constitution of adenin and hypoxanthin, finds that they belong to the uric acid group. When treated with hydrochloric acid at 130° C., they yielded glycolcol, and by a more profound decomposition with bromine, potassium chlorate, and hydrochloric acid, aloxanthin and urea were obtained.

Physical Society, November 20.—Prof. Kundt, President, in the chair.—Prof. A. du Bois Reymond explained, starting from the discovery of electrodynamic rotations produced by alternating currents made by Galileo Ferraris in 1888, how the rotation of the magnetic field is employed in the construction of rotatory current motors, and exhibited several forms of the instrument to the Society. The principle discovered by Ferraris has undergone very material modification during its practical application, and has led to most interesting scientific results.

December 4.—Prof. von Helmholtz, President, in the chair.—Dr. Assmann described his aspiration-meteorograph intended for use in captive balloons.—Dr. Wolff spoke on the permanency of an accumulator battery which had been standing for a year, until the fluid in it had evaporated to dryness, and which, on being recharged, almost immediately recovered its original strength.

Meteorological Society, December 1.—Prof. Schwalbe, President, in the chair.—Dr. Assmann spoke on meteorological observations during balloon voyages and in captive balloons. For the determination of temperature, humidity, and atmospheric pressure in a free balloon, the aspiration thermometer and an aneroid barometer suffice. Comparative measurements made by Rotch in Paris and in Berlin, during balloon voyages, showed that a Richards thermograph records a temperature some 8° C. higher than does a maximum and minimum thermometer, and the latter shows a temperature always 2° C. higher than does an aspiration thermometer. In order to carry out prolonged observations on humidity during a balloon trip, three aspiration thermometers must be combined, of which two are alternately moistened while the third is kept dry. For use in captive balloons self-registering instruments must be employed, whose construction, owing to the frequently violent vertical jolts of the balloon, presents considerable difficulty. The speaker exhibited tracings which showed that these difficulties had been overcome by him. Temperature is recorded by a bent Bourdon tube filled with alcohol, humidity by a hair hygrometer, and atmospheric pressure by an aneroid; all these instruments being placed in a space in which aspiration is continuously kept up. Each instrument records upon a cylinder which rotates once in about five hours. The German Ballooning Society proposes to, make simultaneous observations (1) in a free balloon, (2) with a self-recording apparatus suspended by a long cable from the car of the balloon, (3) with a second similar apparatus in a

captive balloon, and (4) at the earth's surface. By this means simultaneous determinations of temperature, humidity, and pressure at four different air-levels would be obtained.—Prof. Spörer described the appearance of two groups of sun-spots, of which one was unaccompanied by any disturbances of terrestrial magnetism, while the other was followed by very strong disturbances.

## BOOKS, PAMPHLETS, AND SERIALS RECEIVED.

BOOKS.—La Rose; J. Bel (Paris. Baillière).—Les Champignons: A. Aclode (Baillière).—La Place de L'Homme dans la Nature: T. H. Huxley (Baillière).—Analysis of Theology: Dr. E. J. Figg (Williams and Norgate).—Sul Regime delle Spiagge e sulla Regolazione dei Porti: P. Cornaglia (Torino, Paravia).—Reports on the Mining Industries of New Zealand, 1891 (Wellington, Dubsbury).—Annual Report of the Department of Mines, N.S.W., 1890 (Sydney, Chapman).—The Embryology of the Sea Bass: Dr. H. V. Wilson (Washington).—Electricity up to Date: J. B. Verity (Warne).—Studies in Anatomy from the Anatomical Department of the Owens College, vol. 1. (Manchester, Cornish).—The Living World: H. W. Conn (Putnam).—A Natural Method of Physical Training: E. Checkley (Putnam).—Notes on Building Construction, Part 4. (Longmans).—Botanical Wall Diagrams (S. P. C. K.).—Œuvres Complètes de Christian Huygens, tome quatrième (La Haye, M. Nijhoff).—L'Electricité dans la Nature: G. Darv (Paris, G. Carré).—Thermodynamique: H. Poincaré (Paris, G. Carré).—Through Equatorial Africa: H. von Wissmann; translated by M. J. A. Bergmann (Chatto and Windus).—Mission Scientifique au Cap Horn, 1882-1883, tome vii., Anthropologie, Ethnographie: P. Hyades and J. Deniker (Paris, Gauthier-Villars).—Whitaker's Almanack, 1892 (Whitaker).

PAMPHLETS.—Higher Education in India: Dr. J. A. Woodburn (Washington).—Rules for a Dictionary Catalogue, 3rd edition: C. A. Cutter (Washington).—Promotions and Examinations in Graded Schools: Dr. E. E. White (Washington).—Sanitary Conditions for School-houses: A. P. Marble (Washington).

SERIALS.—Journal of the Chemical Society, December (Gurney and Jackson).—Journal of the Royal Horticultural Society, vol. xiii., Part 3 (17 Victoria Street).—L'Anthropologie, 1891, tome ii. No. 5 (Paris, Masson).—The Asclepiad, No. 32, vol. viii. (Longmans).—Botanische Jahrbücher für Systematik, Pflanzenzgeschichte und Pflanzengeographie, Vierzehnter Band, 4 Heft (Williams and Norgate).

## CONTENTS.

	PAGE
Two Zoological Text-books. By Prof. E. Ray Lankester, F. R. S.	145
Modern Artillery. By A. G. G.	146
Giants and Acromegaly	147
Peaks and Passes in New Zealand. By Prof. T. G. Bonney, F. R. S.	147
Our Book Shelf:—	
De la Saussure: "Manual of the Science of Religion."	
—W. R. S.	148
Laying: "Euclid's Elements of Geometry," Book XI.	
—W.	149
Makino: "Illustrations of the Flora of Japan."—	
W. B. H.	149
Clutterbuck: "About Ceylon and Borneo"	149
Letters to the Editor:—	
Wind Direction. (With Diagram.)—A. B. M.	149
The Migration of the Lemming.—F. Howard Collins	150
The New Railway from Upminster to Romford, Essex.—T. V. Holmes	151
Peculiar Eyes.—G. K. Gude	151
Grafted Plants.—W. H. Beeby	151
Intelligence in Birds.—A. Wilkins	151
Sir Andrew Crombie Ramsay. By A. G.	151
On Van der Waals's Isothermal Equation. (With Diagram.) By Prof. D. T. Korteweg	152
The Bird-Gallery in the British Museum	154
The October Eruption North-West of Pantelleria. By Prof. John W. Judd, F. R. S.; G. W. Butler	154
Notes	154
Our Astronomical Column:—	
Jupiter and his First Satellite	159
Spectra of the Sun and Metals	159
Measurement of Jupiter's Satellites by Interference. (Illustrated.) By A. A. Michelson	160
The Samoan Cyclone of March 16, 1889. By H. F. B.	161
University and Educational Intelligence	162
Societies and Academies	162
Books, Pamphlets, and Serials Received	168

THURSDAY, DECEMBER 24, 1891.

## BOTANICAL NOMENCLATURE.

*Revisio Genera Plantarum Vascularium omnium, atque Cellularium multarum, secundum Leges Nomenclaturæ Internationales, cum Enumeratione Plantarum in Itinere Mundi collectarum.* Mit Erläuterungen von Dr. Otto Kuntze. Pp. 1011. (London: Dulau and Co., 1891.)

THE importance of this subject is so great, and the alterations made in this book so revolutionary (although the author pretends to be guided by "international rules"), that a brief sketch of the recent history of plant-naming is desirable in order to render any criticisms of the work generally intelligible; and it is all the more called for because Dr. Kuntze specially attacks the position taken up by a considerable section of English botanists.

From the time of the foundation by Linnæus of the binominal system of nomenclature, which cannot be said to have been consummated before the publication of the first edition of the "Species Plantarum" in 1753, down to within the last 25 or 30 years, matters proceeded with tolerable smoothness, though some influential botanists did not scruple to ignore the published names of their contemporaries, or alter them on the most trivial grounds; and there was almost universal laxity in citing authorities. But the more critical investigation of the European flora especially, and to some extent also, perhaps, the tendency to multiply species, led to a more thorough examination of the literature, resulting in the discovery that the same genus or species had often been described and named by more than one writer, the names being usually different. Furthermore the limitation of many of the genera founded by Linnæus and others was greatly modified, some by narrower circumscription, others by amplification, according to the opinions and inclinations of the writers; and of course it frequently happened that different writers dealt with the same materials independently of, and unknown to, each other. Some of these new genera and species were described or proposed in publications of merely local circulation, and were overlooked by the majority of botanists, and others seem to have been purposely neglected; so that in many instances the current and commonly accepted names were of more recent publication than those of other authors. As there appeared to be no way out of the practice of citing the author of a given combination of generic and specific names, it followed that the only fair procedure would be to adopt the name and give credit to the man who first published a change generally accepted; because the presumption was that it was always possible, and usually probable, that the later author was aware of the earlier publication. If an author published later than another, his names must be relegated to the synonymy. This is all very well in theory, and is not so very difficult to put into practice, so far as recent writers are concerned, once we have proved the identity of plants under different names; but when we come to the older writers, all sorts of doubts and ambiguities arise, and it seems much better to retain generic and specific names

that are as well established as a thing can be in the uncertainties of the relative rank of vegetable organisms. The struggle of literary botanists to bring the law of priority into operation has, as will presently be shown, resulted in successive changes in nomenclature, each one carrying his investigations a little further than his predecessors, and extending the backward limit of authority for the establishment of genera and species, until the whole thing has drifted into a lamentable and undignified race between persons who deal in dates, and are even prepared to make all sorts of evasions of ordinary rules in order to gratify their craze for reviving old names.

It is hardly necessary to say that these successive changes, apart from the great divergencies as to the limitations of genera and species, have a most deterrent effect on the progress of the study of systematic botany, and make it ridiculous in the eyes of persons who regard a name as merely a means to an end.

In 1867 a Botanical Congress was held in Paris, to which botanists of all countries had been invited, and the most important subject discussed was botanical nomenclature. Mr. A. de Candolle had drawn up a most carefully considered code of rules to govern botanists in their writings; and this code was submitted to the assemblage of botanists, each rule being formulated and modified as the majority deemed wise. Finally, the whole was printed and circulated. The fundamental principle of these laws was priority of publication with adequate descriptions, and unfortunately it was made retrospective, without any sufficiently defined statute of limitations. For reasons of their own, the Kew botanists took no part in the proceedings of this Congress; whether wisely or not it would be difficult to determine, and fruitless to discuss. Of course, their position was open to comment and criticism, which have not been wanting; and Dr. Kuntze, while expressing his admiration of the amount and quality of the work done at Kew, deploras the fact that little regard has been paid to remote and obscure priorities. So far he is fair enough; but when he imputes unworthy motives to Bentham, he commits a great mistake, and does grievous injustice to the memory of a man whose sole aim was to advance botanical science, and especially that branch to which he had devoted his life, and which is most intimately bound up with nomenclature. No doubt the authors of the "Genera Plantarum" failed to take up a large number of published generic names; and not being bound down by the law of priority, they were not always consistent, even from the point of view of expediency and convenience, as the surviving author would readily admit. But to suggest that they would not conform strictly to the rule of priority because they would have to undo much of their own work is as disingenuous as it is untrue. The first volume of the "Genera Plantarum" was not completed till 1867, the "Flora Australiensis" was less than half done, and the "Flora of British India" was not commenced; so that, if the authors had had a longing for change and cheap notoriety, they might have re-named a third of the flowering plants of the world. But their idea was to maintain genera and species, as they had been gradually built up, under current names. The opinion of the late Mr. Bentham on this point is clear from the following passage (Journ. Linn. Soc., xix., p. 19) in his "Notes on the

Gramineæ"—the last of the natural orders elaborated for the "Genera Plantarum".—

"Much has been done, however, for the elucidation of the order in local Floras. Already at the close of the last century and the commencement of the present one, several Continental botanists proposed new genera for anomalous European grasses; but these were published in works which entered but little into general circulation, and were overlooked by Beauvois, Persoon, Willdenow, and other systematists. Several of the same genera have since been re-established, but under other names which have now been so long and so universally adopted, that they must be considered as having acquired a right of prescription to overrule the strict laws of priority. It would indeed be mere pedantry, highly inconvenient to botanists, and so far detrimental to science, now to substitute *Blumenbachia* for *Sorghum*, *Fibichia* for *Cynodon*, *Santia* for *Polygonum*, or *Sieglingia* for *Triodia*."

It is idle to argue that two or three persons have no right to make laws; for any corporation, however small, has that right, and is justified in exercising it if it has the power to carry them into effect. But, after all, the main question is, whether the Kew botanists acted in the interest of science in declining to be guided by the rules passed by another body of botanists; and I think any unprejudiced outsider would agree that they did, and that the course events have taken has strengthened their position.

It should be remembered that most of the advocates of priority, and especially those advocates of almost unqualified priority, such as Dr. Kuntze, have no responsibility beyond literary accuracy, and even that cannot be maintained for such uncertain quantities as orders, genera, and species of plants. On the other hand, the botanists of Kew have grave responsibilities towards the general public. It is not too much to say that Kew is almost exclusively responsible for the botanical nomenclature current in gardens, and in English and colonial literature dealing with plants or the products of plants, to say nothing of the vast named collections at Kew. The labour of renaming the plants in accordance with the investigations of successive reformers would have been as nothing to the folly of doing so, though it would have been a herculean task, and a recurring task, as each older name was disinterred. The idea of giving a gardener, or a manufacturer, or any person interested in vegetable products, one of these resuscitated generic names with a specific name tacked on to it by a person who has done nothing else except put his initials to it, is too absurd. All the literature connected with the plant is under another name, all the figures likewise, and, one might add, all the persons almost who know anything about the plant, know it by the old name. Yet, forsooth, we are asked to sacrifice everything that belongs to the present for the sake of a "principle" that involves endless confusion, and feeds the vanity of the living more than it honours the dead. Of course priority in current work is a totally different thing; but if it had been the intention of the promoters of the new "Index to Plant Names," on which Mr. Daydon Jackson and his assistants have been engaged for some ten years, to restore these old generic names, and enumerate the species thereunder, it would now be necessary to cite some 30,000 of them as the com-

binations of O. K. (Dr. Kuntze). It is no disparagement to the literary researches of Dr. Kuntze to say that Mr. Jackson was in a position to do this infinitely better than Kuntze, if it had been desirable to do it. But it was never a part of the plan that the compiler should reduce synonymy, and amend the nomenclature of plants. His task has been to prepare an index, and as such its value will far exceed any attempts at finality in synonymy. To have proceeded on the lines of Steudel would have only resulted in the addition of many thousands of names devoid of all authority. Nevertheless, Dr. Kuntze, being so impressed with the importance of his precious names, declares that the index will have no scientific value unless it include the 30,000 specific names appropriated by "O. K." without more labour than a mere transfer. Dr. Kuntze worked at Kew for several years, and enjoyed the usual privileges of the establishment, and the exceptional privilege of consulting the index in question; and he now very magnanimously dedicates a genus to the compiler, and patronizingly tells him he hopes he will take proper advantage of the researches and superior wisdom of the author.

The extent to which these changes have been made may be gathered from the author's own summary, in which he states that he has reduced 151 genera; separated off 6 genera; re-named 122 genera, because they bore names homonymous with other genera; restored 952 genera in accordance with the laws of priority; and re-named upwards of 30,000 species belonging to these genera! How he justifies these changes may be learnt from a few examples, selected to illustrate the various extraordinary devices employed by a writer who professes to be animated by a sincere desire to reform and consolidate botanical nomenclature. We may waive for the moment another phase of the question—how far can botanists accept these identifications, even if they are prepared to accept the principle? *Astragalus*, a genus of more than a thousand species, is to be superseded by *Tragacantha*, because the latter name was published by Linnæus in his earlier crude "Systema" (1735), though in his revised and improved work he preferred and employed the former. Kuntze says, in fact, that no author can be permitted to revoke any previously published name of his own making, any more than those of another person; and accordingly he transfers page after page of names from *Astragalus* to *Tragacantha*, with the appended authority, "O. K." Other familiar large genera treated in the same way are: *Erica*, which becomes *Ericades*, on an even less tenable ground; *Pelargonium* has to cede to *Geraniospermum*; and *Clematis* receives an additional syllable, and in future we must say *Clematitiss*. Recent authors have combined *Rhododendron* and *Asalea* under the former, but Kuntze now gives them all names under the latter. Proceeding to examples of more far-fetched changes, it may be noted that *Cleistanthus* is to be *Kaluhaburunghos*, though it was only the other day that Dr. Trimen discovered that a plant in Herrmann's herbarium, bearing this name, which was taken up by Linnæus in his "Flora Zeylanica," was the same as *Cleistanthus acuminatus*. Dr. Trimen also identified *Gaedawakha* as of the same origin with *Chato-carpus*, therefore Kuntze restores the former. Another excuse for changing names is the existence of two of the same derivation. Thus *Glaucium* cannot be tolerated by the side of *Glaux*, and Kuntze takes the opportunity of

dedicating the genus to his "dear sister Mary and her husband Franz Mosenthin," and we get the new name *Mosenthinia*. Some other names of the same derivation are sufficiently distinct to avoid confusion, yet Kuntze says they must be treated as homonyms. To this category belong *Hydrothrix* and *Hydrotriche*; consequently the former is re-named *Hookerina*, though a *Hookera* exists and is accepted by our author, who also invents a *Sirhookera*! Failing any of the foregoing reasons, an old name may be modified to conform to modern rules, and then replace a current name. For example, *Katulsjeroe* goes through this process, and is issued as *Calutulsjeron*, otherwise *Holigarna*. In the same way *Anil* becomes *Anila*, and supplants *Indigofera*; *Caju* is lengthened to *Cajum*, and supersedes *Pongamia*; and *Kauken* to *Kaukenia*, swallowing up *Mimusops*. A still more exasperating kind of change is the transfer of a familiar generic name to some other familiar genus; such as *Armeria* to *Statice*. It may be mentioned in passing that the *Plumbaginaceæ* have fared badly at the hands of this wholesale reformer. *Acantholimon* is referred to *Armeriastrum*; *Armeria* to *Statice*; *Vogelia* to *Dyero-phyton*, O. K.; *Limoniastrum* to *Limonioides*, altered by O. K. to *Limonioides*.

Lovers of orchids will probably be long before they adopt the numerous changes effected in the generic names of their favourites. *Dentrobium* is superseded by *Callista*, *Eria* by *Pinalia*, *Saccolabium* by *Gastrochilus*, *Bulbophyllum* and *Cirrhopetalum* by *Phyllorchis*, *Pleurothallis* by *Humboldtia*, and *Angracum* by *Angorchis*—the last by mistake, it would seem, for *Angracum* is really older than the substitute. Why *Epidendrum* does not fall is not explained; for as now limited it does not contain one of the species of Linnæus's original *Epidendrum*; and I believe that *Vanilla* would have to be named *Epidendrum* on the principle adopted by Kuntze.

There is another confusing element in these changes. Dr. Kuntze reinstates a number of Aublet's neglected or previously unrecognized genera, with modified spellings. In this way *Coumarouna* and *Tounatea* become *Cumaruna* and *Tunatea*, giving them a widely distant position in an index. On the other hand, Dr. Taubert has recently adopted the original spellings, and appropriated all the species, so that each species is now saddled with at least three names, in order that justice should be done to Aublet, who described one species of each genus!

But Dr. Kuntze is not the only person who believes, —and conscientiously, I am convinced—that botanical nomenclature can only be established on a firm basis by absolute adherence to the rule of priority. As an instance of the extremes to which some of the American reformers and champions of priority and fixity go, I may refer to the writings of Prof. E. L. Greene. With regard to the authorship of species, he contends (*Pittonia*, i. p. 183) "that according to an acknowledged general principle which governs men, or ought to govern them, in all literary work, whether scientific or general," any binominals now in use in the same form that they happen to occur in pre-Linnæan works, such as those of Ray, Bock, Dodoens, Fuchs, and others, should be credited in all modern books, not to Linnæus, but to such of these sixteenth century authors who first employed the combinations; and he enumerates forty-eight examples

taken from Ray's "Catalogus Plantarum circa Cantabrigiam nascentium." This, not because these authors had any idea of a binominal nomenclature, but because the ordinary diagnostic phrase of the period happened to be reduced to two words. Of course, if we admit species on this ground, we cannot logically date the genera later; and the same writer ("Flora Franciscana") carries out the same principle for genera, and ascribes *Lupinus* to Catullus, *Linum* to Virgil, *Euphorbia* to Pliny, and *Amygdalus* to Theophrastus!

In a more recent article (*Pittonia*, ii. p. 185). Prof. Greene proposes new names for a number of what he terms "revertible generic names"—that is, names which have at some period been applied to some other plants than those for which they are now current, no matter how remote the chance of revivals. On this principle he supersedes *Pickeringia*, Nutt., *Nuttallia*, Torr. and Gr., *Darlingtonia*, Torr., *Cranztia*, Nutt., *Torreya*, Arnott, and others; and, as he asserts, with great regret.

One might go on multiplying instances of these unnecessary changes, but it would only be wearisome. Still, I may give one or two examples of repeated changes, and we are not sure that we are at the end. Sir Ferdinand Mueller, the eminent Australian botanist, reduced *Candollea*, Labill., to *Hibbertia* (Dilleniaceæ), and replaced *Styliidium* by *Candollea*, whilst *Marlea*, in Cornaceæ, was replaced by the older name for the same genus, *Styliidium*. Kuntze now discovers that *Karangolum* is an older name for *Marlea*, therefore he reinstates *Styliidium* for the plants generally known under that name, and *Candollea* of Dilleniaceæ is relegated back; though in the meantime another compiler had invented the name *Eeldea* for it, in spite of its having been reduced to *Hibbertia*. One more instance: *Nymphaea* and *Nuphar* are names familiar in their application to a large number of persons outside of botanical circles, and there was no objection to them until recently, when Mr. J. Britten found that *Nuphar* ought to be *Nymphaea*, and the latter *Castalia*, and he believed he had reached finality in the matter; but Kuntze now says that *Castalia* must fall, because the name *Leuconymphaea* was employed by Ludwig in 1737. And so these changes go on.

On the whole, I think it will be admitted that the Kew botanists have exercised a wise discretion in employing current and familiar names in preference to these uncertain and endless revivals; and I may say that the same policy will be pursued in the immediate future. If the advocates of change succeed in popularizing their ideas of "right" and "justice" in the matter, then, no doubt, Kew would follow, and not unwillingly.

There are endless difficulties in the way of taking up genera anterior to the first edition of Linnæus's "Species Plantarum," and it seems only rational and consistent that binominal nomenclature should be based upon the foundation of the system, and upon Linnæus's completed work, rather than upon his, or other authors', earlier imperfect works. It is no breach of confidence to say that Mr. Daydon Jackson, who has been ten years engaged on Darwin's "Index to Plant Names," has come to the conclusion that any attempt to adopt genera of an earlier date will lead to hopeless confusion, to say nothing of inconvenience.

There are some genuine cases of priority that one

would rather not admit, because there is no advantage gained by them and much confusion is caused, inasmuch as one change often involves several others, and the re-naming of large genera. According to the strict law, *Pimelea* should be *Banksia*, and so Kuntze re-names the latter *Sirmuelleria*.

It remains for botanists, who really write for the public, to decide whether, in a general way, it is not better to employ current names; because it is perfectly ridiculous to vapour about the "scientific" value of names. We might as well attempt to purify the English language. All we want is to know what plant is designated by a given name, and that is no easy matter, apart from other complications.

Since the foregoing was written, I have seen an article (*Botanical Gazette*, November 1891, p. 318), by Mr. E. L. Rand, on "Nomenclature from the Practical Standpoint," in which he recommends the course followed by the Kew botanists, without any reference to them, however, or to Dr. Kuntze, whose work could not have reached America at that time.

V. BOTTING HEMSLEY.

#### APPLIED THERMODYNAMICS.

*Thermodynamics of the Steam Engine and other Heat Engines.* By Cecil H. Peabody, Associate Professor of Steam Engineering, Massachusetts Institute of Technology. (London: Macmillan and Co., 1889.)

SUCH an important work as the present, on a position which has completely changed in the course of this century the conditions of human life, should not have remained unnoticed so long, and an apology is due to the author; our excuse must be that the scope and power of the book are such as to arrest attention and to excite interest in all its various details.

The work forms a noble companion to the "Applied Mechanics" of Prof. Lanza, the author's colleague; and the students of the Massachusetts Institute of Technology are to be congratulated on their staff, and the possession of such admirable text-books, to direct their theoretical and practical studies.

We find a great contrast here with the ordinary treatises on Thermodynamics to which we are accustomed, where the subject is followed up to a great extent for its mathematical interest, and where little appeal is made to the numerical illustrations on a large scale which we see taking place around us; this treatise is written much more in the style of Prof. Cotterill's "Theory of the Steam Engine," where the methods and results of the application of Thermodynamics to engineering are developed.

The book commences with a general theory and formal presentation of Thermodynamics, as employed by the majority of writers (and beyond which they rarely travel), and follows the ordinary notation and treatment, but has the advantage of being illustrated by carefully drawn diagrams of real curves and machines, with collections of instructive numerical exercises taken from real experience; the student can thus test the soundness of his knowledge as he proceeds.

So long as we deal with the Theory of Perfect Gases, the First Law of Thermodynamics will suffice to carry us

forward; and now the best illustrations of theory are to be found in the behaviour of compressed air when used as a motor—for instance, in tunnelling machinery, and in the Whitehead torpedo, or in the working of Refrigerating Machines (chapter xxi.), now of such importance in the New Zealand dead meat trade.

The Second Law of Thermodynamics is introduced in chapter iii., as a formal statement of Carnot's principle, and this again as an experimental law. Statements of this law are of various kinds, but the two given here seem to put the matter in as clear a light as possible:—

(1) All reversible engines, working between the same source of heat and refrigerator, have the same efficiency, *i.e.* the efficiency is independent of the working material.

(2) A self-acting machine cannot convey heat from one body to another at a higher temperature.

This is almost equivalent to the convention that, of two bodies, the one to which heat passes by conduction or radiation has the lower temperature.

Sir W. Thomson's definition of an Absolute Scale of Temperature is now deduced from Carnot's principle; and the correspondence of this scale with that given practically by the air thermometer is found to be so close that they may be taken as coincident.

The theoretical advantages of Superheated Steam (chapter viii.) have led inventors to repeated and costly failures in their attempts at its employment, due to a simple humble cause, the consequent destruction of the dirty greasy film of lubricant, which keeps the working parts from cutting and seizing.

It is related that the introduction of the compound principle (chapter xiii.) into marine engines was due to an attempt at the employment of superheated steam, and that the removal of the superheaters revealed the superiority of the compound engine.

The substance employed to do the work in a steam engine is now invariably "Saturated Vapour" (chapter vii.), the worst substance to choose, according to the precepts of pure Thermodynamics.

The Laws of Saturated Vapour are empirical, and deduced from the experiments of Regnault. Here, as throughout the book, the results are expressed in British units of the foot and pound, while the gravitation unit of force is employed, being the force of a pound in latitude  $45^\circ$  at sea-level.

Prof. Rowland's latest determination of the Mechanical Equivalent of Heat is used, namely  $427 \cdot 1$ , in Metric Units of metre-kilogrammes per calorie at  $16\frac{2}{3}^\circ \text{C.}$ , or  $778$  foot-pounds.

The Laws of the Flow of Fluids, investigated in chapter ix., are applied immediately to the theory of Giffard's beautiful invention, the Injector, in chapter x.

Working diagrams are given of all the principal variations of the application of the Injector, an instrument in which a jet of steam, by reason of its excess of energy and momentum, is capable not only of overcoming an opposing jet of water from the same boiler, but also of carrying with it, in a condensed form, a much larger quantity of water, and thus feeding the boiler. Still more paradoxical, even the exhaust steam of an engine can be made to perform the same office against a pressure several fold greater. The Injector is working to the best advantage when feeding a boiler, as the heat of the steam

jet is returned back again; and although the efficiency is small, when compared with a pump, still the Injector has the advantage of working while the engine is at rest.

The same principle is applied occasionally in the Water Injector and the Ejector, where, for instance, a large body of water, in the form of leakage or water ballast, is to be rapidly cleared out. A somewhat similar instrument, although quite different in principle, is that called the Pulsometer, which is really a revival of the Marquis of Worcester's and Savory's Fire Engine, where the pressure of steam acts directly on the surface of the water. To check the great condensation a piston was introduced, and hence our modern steam engine.

Hot Air Engines are described in chapter xi., and here the mathematical theorems for Perfect Gases receive their most beautiful applications, so that formal treatises on Thermodynamics usually treat this part of the subject at length. Our author dismisses it in about eight pages, with a short description of the principal systems, as, unfortunately, all the practical objections against the use of Superheated Steam are intensified tenfold in the Hot Air Engine. Ericsson once fitted a steamer to cross the Atlantic with engines on this principle: they were very cumbersome although the boilers were dispensed with; and the experiment did not lead to further imitation. An exception must be made in favour of the Gas Engine, as the only practical application of the Hot Air Engine; the author works out the theory, and comes to the remarkable conclusion that the efficiency of the Gas Engine Cycle does not depend, as in ordinary Thermodynamics, on the difference of temperatures so much as on the degree of expansion and compression.

The author reaches the real part of his subject in chapter xii., where he discusses the theory of the Actual Steam Engine, as we really find it working, in the mill, mine, and on the railway or steamer.

Here Hirn appears as the great authority on the careful records of what takes place in the actual engine (chapter xvii.).

"The measurement of quantities of heat, especially when it has to be done in an engine at work, is an operation of great difficulty; and it was not till 1862 that it was shown experimentally by Hirn that  $\frac{1}{2}$ , the heat emitted, is really less than  $H$ , the heat received by the engine" (Maxwell, "Theory of Heat").

The example of Hirn has been followed up of recent years by careful and long-continued experiments on steamers and pumping engines in regular work, and the results of the most important of these tests receive careful description and analysis, in chapters xv.-xviii.; a preliminary chapter, xiv., giving a detailed account of the best procedure and instruments required in Testing Steam Engines.

The book will be found indispensable, not only by designers of Steam Engines, but also by writers of abstract treatises on Thermodynamics, as restraining their mathematical development within reasonable limits of actuality, and as directing their analytical powers in a useful direction.

A. G. GREENHILL.

### BRITISH FLIES.

*An Account of British Flies (Diptera).* By the Hon. M. Cordelia E. Leigh, F.E.S., and F. V. Theobald, B.A., F.E.S. Vol. I., Part I. (London: Elliot Stock, 1891.)

THE reader involuntarily glances back at the title of this work when the first words that meet his eye on the front page are: "One of the branches of science that has advanced with rapid strides during recent years is geology. . . ." To commence with Fossil Diptera, and to enumerate the families (and some of the genera) members of which are found preserved in the earth's strata, before either families or genera have been in the least degree defined, is a somewhat novel way of beginning. When the work is completed, students will find it useful to transfer chapter i. to the end. The second chapter, entitled "Classification of Diptera, with an introductory account of the ancient and modern classification of Insecta," contains much matter of interest to entomologists in general, although it is questionable whether the authors have arranged their material in either the most attractive or the most methodical form. The classification of the Diptera it is intended to follow is that of Verrall, published in 1888, in which the order is divided into two great sections—the Orthorrhapha and the Cyclorrhapha; the Nematocera and Brachycera being included in the former, and the Proboscidea with the Eproboscidea in the latter. The Aphaniptera (now included in Nematocera) form the subject of the third chapter, in the course of which this first part terminates. The structure and metamorphosis of *Pulex* are discussed at some length, and certain species are described in detail. Some uncertainty seems to exist in the authors' minds as to how many of them are engaged upon the work, for they use both "we" and "I." This calls to the recollection Cruikshank's picture, "In which there is Antagonism of interest yet Mutuality of object."

It is not possible from a perusal of the first thirty-two pages to form a fair idea as to the general character of the work. It may be stated, however, that it appears to be written for those who are already entomologists, a familiarity with entomological science on the part of the reader being assumed by the authors. Considerable trouble has evidently been taken in consulting authorities whose works are accessible only to the few. That there is plenty of room for a good treatise on the British Diptera will readily be admitted, and if the authors should have something new to tell about such genera as *Chlorops*, *Oscinis*, *Cecidomyia*, and *Hylemyia*, so much the better. Part I. is illustrated by five woodcuts.

### OUR BOOK SHELF.

*Principles of Agriculture.* Edited by R. P. Wright, F.H.A.S. (London: Blackie and Son, 1891.)

THE *raison d'être* of this little volume is to be found in its "tail," where are reproduced the questions set in the Science and Art Department Examinations in the Principles of Agriculture during the last eleven years. The title-page ought to state, but it does not, that this is a revised edition of a book that was published some years ago. This fact is only discoverable from the preface. The original edition was arranged in three

parts, whilst the current edition is in four parts. The added part is somewhat of a jumble, inasmuch as it is supplementary of each of the first three parts. The scheme of the book is not apparent from the list of contents, and this omission results in confusion. Whilst, however, the arrangement of the book is bad, the matter is good. In skilful hands, indeed, the material which is here accumulated might have been very attractively presented. At p. 132, a dozen pages are commenced on the pests of the farm, whilst another dozen pages devoted to the same subject begin on p. 180. At p. 71, the reader enters upon 30 pages about manures, and at p. 167 he gets a further dozen pages also upon manures. And so on.

With reference to the fixation of nitrogen by leguminous plants, mention is made of the presence on the roots of these plants of "little bag-like enlargements, or tubercles as they are called." It is unfortunate that this effort should be made to associate the pathological term "tubercle" with these structures. The word "nodule" is much preferable, and is not less explanatory.

Despite the fact that the book has been written to enable candidates to "pass an examination," it is as useful and trustworthy a little treatise of the kind as we have seen.

*Elementary Trigonometry.* By J. M. Dyer and Rev. R. H. Whitcombe. (London: George Bell, 1891.)

THE title of this book is on all fours with the contents. The work is well adapted for school use. The explanations of book-work are clearly expressed, and the text is amply illustrated by a store of exercises. Sufficient ground is covered to meet the wants of average Army pupils.

We have detected errata in the text on pp. 21, 30, 36, 59, 61, 62, 65, 67, 74, 80, 101, 136, 153. The major part of the proof-sheets has been carefully gone over, but occasionally, as we have indicated, the authors have nodded. The printing in places, in our copy, is defective. But these faults only slightly mar a work which treats a hackneyed subject with all the freshness one can look for in an elementary text-book.

#### LETTERS TO THE EDITOR.

[The Editor does not hold himself responsible for opinions expressed by his correspondents. Neither can he undertake to return, or to correspond with the writers of, rejected manuscripts intended for this or any other part of NATURE. No notice is taken of anonymous communications.]

#### Opportunity for a Naturalist.

SINCE the completion of "Argentine Ornithology," in which was given an account of the 434 species of birds then known to occur in the Argentine Republic, Mr. Arthur Holland, of the *Estancia Esparilla*, and Mr. J. Graham Kerr, of the Pilcomayo Expedition, have made excellent contributions to the same subject, and have added some 30 species to the Argentine avifauna. But much more remains to be done, and, in continuation of the work, I am now anxious to get a good series of birds from Uruguay, the fauna of which, so far as we know it, does not appear to differ materially from that of its neighbouring Republic. For this purpose I have made arrangements with a friend to take in a naturalist at his *Estancia*, near Minas, about sixty miles from Monte Video, and am looking for a qualified collector to occupy the post. His necessary expenses will be met, but his further remuneration must be end, more or less, on the results obtained. May I ask the aid of NATURE to make known this eligible opportunity for a young naturalist who can make good birds'-skins, and is anxious to pass a few months in a foreign clime?

P. L. SCLATER.

3 Hanover Square, London, W.

#### Warning Colours.

MR. BEDDARD, in his letter published in NATURE of November 26 (p. 78), calls attention to Dr. Eisig's suggestion that

NO. 1156, VOL. 45]

those bright colours of animals which have hitherto been regarded as of warning significance are merely the substances which confer the unpleasant taste, and that therefore the older interpretation is unnecessary and in fact erroneous. The writer furthermore implies that Dr. Eisig's views are not alluded to by those who have written upon animal colours, because they have escaped their attention. There is, however, another possible explanation of such neglect, and one which in my own case is certainly the correct one—viz. that the views in question appear to be so inherently improbable that a large body of confirmatory evidence is required before they demand attention. I do not by this mean to suggest that the unpalatable attribute may not possess a bright colour: this is certainly often the case, especially with the secretions expelled by many insects when they are irritated. But it is highly improbable that these facts afford any refutation of the theory of "warning colours"—that is, of the view which regards the bright and conspicuous colouring as an indication (in mimetic forms a false indication) of some unpleasant attribute, whether associated or unassociated with the colour itself. And as regards the bright colours of Lepidopterous *imagines*, such associations, to say the least of it, entirely unproved. It by no means follows that the yellow colouring of the brimstone and other butterflies is disagreeable in flavour because it "is due to a substance formed as a urinary pigment." And the relation of many animal colours to these pigments by no means necessarily implies unpalatability. Again, it would be impossible to regard merely as a coincidence the fact that the substances in question almost invariably produce a conspicuous appearance, and, furthermore, produce it in a variety of ways. Such an appearance is, as is well known, not merely due to the individual colours, but to their mutual arrangement and relationship. It is due, moreover, to a variety of physical principles, for the production of white is very different from the production of the colours which are so often contrasted with it. Conspicuous effects are furthermore often gained without the use of pigment, as in the brilliantly metallic pupæ of *Euplexa core* and of *Mechanitis lysimnia*. Hence the contention that the bright colour of distasteful insects is a mere incident of chemical composition which has been selected on other accounts is so inherently improbable that it would require a large body of evidence to support it.

But perhaps the strongest argument against the view is that it creates such an artificial distinction between inedibility due to mere unpalatability, and that due to other unpleasant attributes. Mr. Beddard would probably admit that the conspicuous colouring of the skunk, the coral snake, and the wasp possesses a true warning significance; and yet he would interpret the black and yellow colouring of the larva of the cinnabar moth or the pupa of the magpie moth (both known to be unpalatable) in an entirely different way, and would deny that it possesses a warning meaning.

In addition to these considerations, the undoubted existence of an unpalatable quality not residing in the superficial pigments is quite clear in many brightly coloured insects. The irritating hairs and odoriferous secretions of many Lepidopterous and Hymenopterous larvæ, and the evil-smelling yellow fluids which exude from *Coccinellidae* and from many conspicuous butterflies are examples.

The recent investigations of the distinguished Russian naturalist Portchinsky (II. "Coloration marquante et taches ocellées, leur origine et leur développement," St. Petersburg, 1890) have, among other things, shown us the distinct manner in which the colours which attend unpalatability are displayed by the insect when it is disturbed. He thus explains some of the cases of "shaming death" which are so often alluded to in works on insects (the other cases being explained by the necessity for concealment). Two examples which he adduces are so interesting, and have so important a bearing on this discussion, that I cannot resist the temptation of reproducing them here, especially as Portchinsky's paper, being written in Russian, is almost unknown in this country. I have, however, been most kindly helped by my friend Mr. Morfill, and now possess a complete translation, which I hope soon to publish. The female of *Spilosa mendica* possesses black and yellow legs, and, when disturbed, it folds its limbs and drops to the ground, generally falling on its back, so that the contrasted colours are displayed (see Fig. 1). In the closely allied *Spilosa urtica* the dorsal surface of the abdomen is black and yellow, and this insect, when irritated, raises its wings and curves the abdomen downwards so that the colour is conspicuous. Furthermore,



only its first pair of legs are black and yellow, and these alone are stretched out conspicuously (see Fig. 2). The great differences between the attitudes of these two closely related moths, corresponding to the distribution of startling colours upon them, afford a very strong support to the theory of warning colours. Mr. Beddard might reply that they thus make prominent the unpalatable pigments that the enemies may first



FIG. 1.



FIG. 2.

make trial of them upon a material which will ensure their ultimate rejection. But if the colour has not a meaning as such, there is no reason why this spot should be attacked in preference to any other part of the exposed surface; and the existence of the colour as a covering to the most vital parts seems to indicate that it acts as a warning away rather than in the reverse manner.

The fact that brightly coloured animals are frequently attacked does not seem to me to be a great difficulty. The really important point is whether the enemy remembers the attack, and is assisted in identifying the unpalatable species by its bright colours. Many experiments seem to show that this is so. Certainly Mr. Beddard will not assert that the majority of insect-eating animals fail to know and recognize a wasp without tasting it. Again, the question is really, as Mr. Titchener implies in his interesting communication, one of "comparative palatability"; and there is no doubt that insect-eating animals when sufficiently hungry will attack and sometimes devour insects which they would ordinarily reject. Furthermore, an animal which naturally prefers a varied insect food, and which is fed in confinement largely on other substances and partially on a monotonous insect diet, may be expected to be less scrupulous than it would be in the wild state. I may state, however, that the most intelligent insect-eating animals, such as the marmot etc., hardly ever make mistakes; their suspicion being at once aroused by any trace of a warning colour.

It is well known that we chiefly owe the theory of warning colours to Mr. A. R. Wallace. My own conviction of its entire validity rests upon the results of a prolonged series of experiments, of which only a part has been published. I believe that I conducted these experiments fairly, that my mind was open, and that I had no personal bias in the matter at all, either in favour of or against the theory. And I can confidently make the same claim on behalf of others who have experimented in the same manner—such as Mr. Jenner Weir, Prof. Weismann, and M. Portchinsky. I may allude especially to the writings of the last-named authority, as they are the most important as well as the most recent contribution to the theory which we owe to Mr. Wallace.

I may also take this opportunity of replying to a very similar objection raised by some reviewers against my book on the "Colours of Animals, their Meaning and Use, &c." They point out that I have not alluded to Eimer's work on the comparison of the wing markings of *Papilionidae*, and they assume that his paper has, therefore, escaped my attention. But Eimer's paper has no bearing whatever on the value of colour in the struggle for existence, and this is the subject of my book, as anyone can infer from the preface, or even from the title. For this reason I was also compelled to omit reference to what I venture to regard as the far more important work of Weismann on the development of the colours and marking of caterpillars, and of Dixey on the wing-markings of *Vanessidae* and *Argynnidae*, as well as a very large proportion of my own work, which is a continuation of that begun by Weismann, and was, in fact, inspired by it.

EDWARD B. POULTON.

Oxford, December 15.

NO. 1156, VOL. 45]

My friend Prof. Meldola has drawn my attention to a communication by Mr. F. E. Beddard in NATURE of November 26 (p. 78), in which the view is expressed that the brimstone butterfly (*Gonepteryx rhamni*) is rendered protected or unpalatable by the yellow pigment of its wings being due to a substance formed as "a urinary pigment," and that the coloration is "a consequence of the deposition in the integument of bitter pigments."

The following objections may be urged against the view that this coloration, said to be of the nature of a "urinary pigment," affords any protection whatever.

*Gonepteryx rhamni* itself has its female much paler than the male and of a greenish-white hue, whilst the wings in both sexes are of a leaf-like appearance, which can only be due to the process of natural selection, and can scarcely have been exercised in the direction of "protective resemblance" if the insect was already unpalatable by the "urinate" nature of the yellow pigment of its wings.

Yellow Lepidoptera have certainly no immunity from the attacks of birds; on the contrary, the scanty records we possess of these onslaughts go to prove that the contrary is the case. The late Mr. P. H. Gosse observed one of the greenlets (*Vierosylva calidris*) to pursue a species of *Terias* in Jamaica ("Birds of Jamaica," p. 194). In Southern India, Mr. E. L. Arnold found the principal victims of the green bee-eaters to be specimens of *Terias hecate* ("On the Indian Hills," vol. i. p. 247-48). Quite recently in the Transvaal I have observed the wagtail, *Motacilla capensis*, to pursue and devour the yellow Lithosid moth, *Binna madagascariensis*.

But the facts of "mimicry" seem to effectually dispose of the supposition. In South Africa, the yellow black-margined *Papilio cenea* affords by its females the most striking examples to prove the non-protective value of this coloration; for the females respectively mimic those two well-known "protected butterflies," the blackish *Amauris echeria* and the reddish *Danaus chrysippus*, whilst, to add to the negative evidence, the yellow male has been seen by Mr. Weale to become the prey of the flycatcher, *Tchitra cristata*.

On the Amazons, Mr. Bates has long since shown that the yellow and black *Leptalis orise* mimics the markings—even to the colour of the antennæ and the spotting of the abdomen—of the protected or unpalatable *Methona psidii*.

Russell Hill, Purley, Surrey.

W. L. DISTANT.

#### A Difficulty in Weismannism.

IN his communication of November 28 (NATURE, December 3, p. 102), Prof. Hartog asks us to believe that Weismann, in a letter from which he quote, insists (1) that the Ahenplasmas are "not completely unchangeable," and (2) that "each Ahenplasma unit corresponds to an individual of the species itself; and if put under suitable trophic conditions would, singly, reproduce such an individual."

Assuming that thesis II. adequately represents the Freiburg Professor's latest views, and that a few sentences detached from their context are to be depended upon, we must, it seems to me, conclude, with Prof. Hartog, that he has unearthed an inconsistency, and what is of more importance, shown that the shuffling process is not only unnecessary, but that a new significance must be found for it.

I am, however, still inclined to believe that hypothesis B is the one upon which Weismann has founded his theories of heredity and sexual reproduction. The hypothesis, however, should take account of the variability, slight though it may be, of the Ahenplasmas. We agree to call the Ahenplasmas Protozoa, simply because we have no conception of the kind and amount of the variation they have undergone since they parted company with the unicellular organisms in which they originated. We have no reason, however, to believe that the external causes which led to their variation in unicellular organisms are powerless to affect them now that they are localized in the reproductive cells of multicellular ones.

Prof. Hartog, moreover, while relinquishing the idea of the variability of the offspring of the liness, endeavours from another point of view to attack Weismannism on the plane of hypothesis B. Is he, too, sceptical as to Weismann's adherence to hypothesis A, or does he simply wish to overwhelm the so-called disciples?

In either case, several objections may be made to his argument. In the first place, we object most emphatically to any

theory of Weismannism *minus* natural selection. In the *second place*, we believe that Weismann means *permutations*, though he uses the term *combinations*. After a football team has been selected, the men can be arranged in  $n!$  different ways. The arrangements would virtually constitute new teams, and newspapers would speak of them as strong and weak combinations. The combinations of the Ahenplasmas can be assumed to be of a similar kind. The arrangement almost certainly counts for something. Nevertheless, Prof. Hartog's contention—that the elimination of Ahenplasmas in the shuffling process would lead to ever-increasing simplicity—demands serious consideration, for duplication lessens the possible number of permutations and combinations. I would point out that we may conceive that the Ahenplasmas were, in asexual unicellular organisms, either *all the same, all different, or in intermediate conditions*. In any one of these cases we must assume that  $m$ , the number of individuals, was much greater than  $n$ , the number of Ahenplasmas present in every individual. With the evolution of sexuality (all the individuals being different) we should get combinations of, at least,  $m$  Ahenplasmas taken  $n$  at a time. Different permutations of the same combination would be, of course, possible, giving rise to other combinations, using the word in the general sense. We must suppose that natural selection operated upon the variations produced by these first combinations. Natural selection had operated upon the unisexual ancestors of these sexual forms. We can at least conceive that development would follow one of two courses. Along the *first*, combinations in which more than one unit of a kind appeared would, if possible, be prevented. Such might arise, but under the operation of natural selection they would not be allowed to perpetuate themselves. Along the *second*, such combinations might arise and be perpetuated. In either case, it must be assumed that the combinations which survived were such as were best adapted to the varied combinations of external conditions. This may be made clearer by an illustration. In Rugby football, combinations of 15 in which 8 or 9 of the men—the forwards—are all the same would be strong, whereas, if all were different, they would be weak. In Association football, strong combinations could only be made up by selecting different types of players for the different places. I am inclined to believe that both cases are followed by Nature. The one which I have illustrated with reference to Rugby football cannot, however, have been generally followed. It is an adaptation for which the organism has ultimately to pay dearly, and is as dangerous to the development of the *phylum*, as we may suppose parthenogenesis to be to the *species*. Taking the case of plants, I would say that the one course may have been followed along the line of development of the main archegoniate series, the other in the development of such divergent groups as the Ustilagineae and Gastromycetes. The argument of Prof. Hartog, therefore, while of no avail as directed against Weismannism, is of use in so far as it enables us to better understand *divergence*. I am inclined to think that it may serve also to explain the remarkable *persistency* of such forms as Nautilus. It suggests, too, an explanation of the disadvantage of breeding "in and in." *Finally*, I would remind Prof. Hartog that neither of the disciples of Weismann apparently believes in the non-variability of the Ahenplasmas. If their beliefs have a substantial foundation, it follows that the number of possible combinations becomes absolutely unthinkable.

I shall be much obliged to Prof. Hartog if he can inform me of any theory of heredity whose foundations are not "more or less mythical." There are, no doubt, many difficulties in Weismannism, before one of which, the theory, having served its time, may come to the ground. I do not think that Prof. Hartog's is one of them.

Penarth, Cardiff, December 10.

A. H. TROW.

#### Destruction of Immature Sea Fish.

IN your number of November 19 (p. 49) you review the Ninth Annual Report of the Scotch Fishery Board. I have not seen the Report, but assume that your reviewer's statements as to its contents are correct. My object in writing is to draw attention to the opinions attributed to Dr. T. Wemyss Fulton as to the destruction of young fish by shrimpers. I may say at once that I am one of the "very many" to whom the "results" are "surprising" as your reviewer remarks. I am an old shrimp-trawler in the Dee and along the Flintshire coast, and I have no hesitation in saying that, as regards the Dee and, I believe, the

Mersey and the Lancashire coast as far north as the Ribble, the destruction of young fish is absurdly under-estimated, whether I judge by my own experience or by that of Mr. R. L. Ascroft, of Lytham, with whom I have been in correspondence on the subject since 1889. This gentleman, however, informs me that Dr. Fulton's information was obtained from Morecambe Bay, where smaller trawls are used, and the boats drift with the tide instead of sailing. Dr. Fulton has been informed that in the Solway Firth a single boat in one year captures over 100,000 immature plaice. If the word "year" is not a mistake for "week," either the statement is immensely under-estimated or the conditions in the Solway must be very different from what they are further south. This may be judged by the following extract from a letter written by Mr. Ascroft in 1889. I may say that this gentleman (who is now, I am glad to say, a member of the Lancashire Fishery Committee) has had a long and practical experience in all kinds of sea-fishing on the Lancashire coast, and is a careful and accurate observer. He writes as follows:—"Shrimping destroys more young fish than almost any other agency. I have seen in Formby Channel 10 cwt. of young flukes destroyed, not one the size of half-a-crown, by one boat, and there were sixty boats there that day."

Now, taking the weight of a fluke the size of half-a-crown at  $\frac{1}{2}$  oz., a simple calculation will show that each boat captured 35,840 young flukes (a term which includes plaice and dabs) in one day, or 215,040 in a week of six days—nearly twice as many as Dr. Fulton's figures for a year! And elsewhere Mr. Ascroft says:—"You may put it as an axiom that 90 per cent. of fish that comes on a boat is destroyed, as when trawling they sail back as they have got their net, and do not commence sorting the take until the net is out again, and they do not, in shallow water, throw the rubbish" (*i.e.* everything except shrimps) "over until they turn out to haul, for fear of getting it into the net again." All of which I may say is borne out by my own experience.

The following is an extract from my diary, written July 10, 1885, when Fishery Committees were not dreamt of. The occasion was an excursion for dredging purposes of the Chester Society of Natural Science, when I took my boat and trawl to meet their steamer at the mouth of the Dee. The Green Buoy marks the bar near Prestatyn, and I let down the trawl in mid-channel (about 5 fathoms) in the hope of getting some natural history specimens:—"Began to trawl just below the Green Buoy. Got a few goodish soles, and an immense number of young soles, which always squeeze their heads through the meshes. (N.B.—Shrimp-trawling at this time of year should only be allowed within a quarter of a mile of the shore, to avoid the immense destruction of fry, which mostly lie further out.) Afterwards got a good haul of shrimps as close in (shore) as we could go." I have a perfect recollection of the occasion, and although the trawl was only down about twenty minutes I was horrified at the number of young soles which were in the net, and most of which had choked themselves. But there were very few shrimps, which mostly lie in very shallow water near the edge of a sand-bank.

As a remedy for this destruction I would suggest that the principal breeding-grounds be ascertained, and trawling on them prohibited at such times as the young fish are there. If the prohibition be evaded, then a steamer-load of very large angular stones, distributed from 100 to 200 yards apart on the selected grounds, would effectually prevent trawling, and at the same time, as they became covered with weed, afford shelter and food to the fish and shrimps. This has been done by Nature in this bay, where large boulders washed out of the drift that here forms the coast-line strewn the shore at wide intervals, and render trawling for shrimps impossible, though hand nets can be and are worked.

I trust the importance of the subject will excuse the length of this letter.

ALFRED O. WALKER.

Nant y Glyn, Colwyn Bay, December 14.

#### The Salts in Natural Waters.

THE inquiry of your correspondent "R. B. H.," in NATURE of November 26 (p. 78), may be answered as follows. In the analysis of an ordinary water, after determining the respective amounts of lime, magnesia, (soda), carbonic acid (combined), sulphuric acid, nitric acid, and chlorides (these being the constituents met with usually in such a water), we proceed to combine the acids and bases thus: the carbonic acid is calculated to carbonate of

lime; if there be more than sufficient to satisfy all the lime, the remainder is calculated to carbonate of magnesia; if there be too little, however, the remaining lime is combined with sulphuric acid; any remaining sulphuric acid is calculated to sulphate of magnesia, and so on; the order in which the bases and acids are taken being therefore as follows:—

Lime, Magnesia, Soda.	Carbonic acid, Sulphuric acid, Nitric acid, Hydrochloric acid.
-----------------------------	---

Now, although this is the usually accepted and conventional method of returning an analysis, there is no doubt that the assumptions it involves are altogether arbitrary, illegitimate, and unscientific. The only scientific method of returning a water analysis is to represent (in parts per 100,000; not in grains per gallon, as the atrocious English system of weights and measures generally compels us to) the constituents *actually found*; as, for instance,

CaO; MgO; CO<sub>2</sub>; N<sub>2</sub>O<sub>5</sub>; Cl; &c.

This is all that an analyst is entitled to say, and this much is certain: when we proceed to combine the constituents, we are dealing in conjecture.

Unfortunately, however, it seems to be a "law of Nature" that those classes of the community who chiefly require the services of analysts are absolutely ignorant of the merest rudiments of chemistry; the consequence is that if any analytical purist endeavours to reform upon the conventionally established procedure, and to return a certificate of analysis in a scientific manner, his clients are up in arms at once, and indignantly demand what he means by sending them such a nonsensical rigmarole.

Thus far, then, we are helpless; but it is *most undesirable* that this conventional procedure should be adhered to whenever it is possible to substitute the scientific (as in an analysis of purely scientific interest).

"R. B. H." asks what salts really exist in solution.

According to Ostwald and others, *no salts at all* if the solution be dilute enough, but only dissociated ions with electrical charges. But whether this theory be correct or not, it is improbable to the last degree that an analysis represents the salts actually present. The indeterminateness of the problem is clearly shown by the fact that from the same solution either sodium chloride and magnesium sulphate, or sodium sulphate and magnesium chloride, may be obtained, according to the method of crystallization adopted. Even supposing that Ostwald's theory be incorrect, and that not ions but salts exist in solution, and that these different results be due to double decomposition occurring in one case, it would be a gigantic assumption that we can definitely show the exact natural distribution in a complicated solution containing eight or ten constituents.

If "R. B. H." wishes to see an account of how acids and bases distribute themselves in a simple solution, he may consult Ostwald's "Outlines" (p. 338, &c., English translation), and also the discussion on *avidity* in Lothar Meyer's "Modern Theories of Chemistry" (472-87). F. H. PERRY COSTE.  
7 Fowkes Buildings, Great Tower St., E.C., Nov. 28.

I AM much indebted to Mr. Perry Coste for his clear and candid answer to my question. It is exactly the answer which I anticipated. The actual facts established by analysis are too often forced, by the arbitrary assumptions of the analytical chemist, to yield unwarrantable conclusions.

The reason given is, that "the people love to have it so." I had hoped that chemists could give some better grounds for their proceedings. They bring to mind the words of the old prophet: "A wonderful and horrible thing is come to pass in the land; the prophets prophesy falsely, . . . for 'my people love to have it so; and what will ye do in the end thereof?' Surely we may henceforth claim, in the interests of truth or (which is the same thing) science, that chemists will give us in every case the actual facts obtained by analysis; and if they proceed further for the sake of the prejudices of the ignorant, they will at least warn them that such further inferences are not trustworthy, and have only a very moderate amount of probability, if they can even lay claim to any probability at all.

I speak feelingly, because I have had occasion to examine a great number of analyses of water from the chalk of the London Basin, telling me, in most cases with a "cocksureness" which has amazed me, what salts, and what amount of them, these waters contained, and these, for purposes of comparison, I have

had painfully to reduce back to the real facts from which they were derived.

I am quite prepared to believe that the investigations of Ostwald and others as to solutions show that salts *as such* do not exist in these waters at all, and that the relations of acids and bases in such cases are variable with the physical condition of the water. As an instance which has come under my own notice, it was reported by competent chemists, with reference to water from a deep well in Harrow, in which an unusual quantity of magnesium and sulphuric acid was found, that at 60° F. its hardness was 10°·4 (grs. per gall.); that, mixed with an equal quantity of distilled water, its hardness rose to 24°; while at the temperature of 158° it rose to 26°·5. I suppose that a chemist would hardly attempt to assign with much confidence what exact changes in the relations of the dissolved constituents would produce these and similar results. All the more reason, then, why analysts should limit themselves to statements which they can vouch for by direct observation and the balance.

My remarks having extended beyond a mere question, I think it best to sign myself in full,  
ROBERT B. HAYWARD.

### Peculiar Eyes.

MR. SHAW'S case is by no means so peculiar as he supposes. I imagine that everyone who has had to do with experimental questions of physiological or psychological optics has found it to be rather the exception than the rule that an investigation of his reagents' eyes has shown their perfect equality—as regards "long" and "short" sight, colour sensitivity, and sensitivity to light. The common preferential use of one eye explains a good deal (cf., e.g., Aubert, "Physiol. d. Netzhaut," p. 18; Schön, *Arch. f. Ophthalmologie*, xx. 2, p. 271). Mr. Shaw may also be colour-blind in one eye; the perception of colour difference alone is no criterion. I find it safest to employ the wool, spectrum, and coloured-card tests in combination.

Animals (with the exception of the very highest) have normally a so restricted binocular vision that they need not be taken into account.

It may be interesting to note that a like difference of sensational capacity exists between the two ears. A tuning-fork held to one ear may, quite normally, drown a tone-sensation which is half a musical tone deeper or higher than that excited by the same fork in the other ear. E. B. TITCHENER.

P.S.—I discovered the very considerable inequality of my own eyes quite accidentally in my sixteenth year.

### Alleged Pseudopodes of Diatoms.

WILL you allow me to express my concurrence in your criticism (p. 140) on Mr. Grenfell's paper on the occurrence of pseudopodia in the Diatomaceous genera *Melosira* and *Cyclotella*? I express no doubt on the accuracy of Mr. Grenfell's observations, the knowledge of which I have derived from his paper in the *Quarterly Journal of Microscopical Science*, and from his verbal description at a meeting of the Linnean Society; but I do desire to enter my protest against the use of the term "pseudopodia" for the protoplasmic filaments observed by him. According to the accepted meaning of this term, it is applied to masses of protoplasm which are in organic connection with the protoplasm of the body of the organism, and which are retractile. I understand Mr. Grenfell that he is unable to affirm either of these facts with regard to the structures observed by him; and, until this is done, the application to them of the term "pseudopodia" appears to me to involve a begging of the question at issue, and a needless and regrettable confusion in terminology. ALFRED W. BENNETT.

### Intelligence in Birds.

UNDER this head Mr. Wilkins, in your last impression (p. 151), speaks of *Podoces pammari* hiding food in the sand. I have a fox-terrier puppy which was taken from his mother when about seven weeks old, and sent to me. I have no other dogs, nor has he seen any dogs, but he buries bones in the garden with great skill, digging a hole with his fore-paws. He puts in the bone, and carefully pushes it down with his nose, and then covers it with garden soil, which is pushed in with his nose. The work is very carefully and elaborately well done.

I have had, at various times, very many dogs of all kinds and ages, but I never saw so young a puppy bury bones, or any dog do it so well. It is an admirable example of pure heredity.

Norfolk Street December 19.

JOE.

A NEW LOCALITY FOR METEORIC IRON,  
WITH A PRELIMINARY NOTICE OF THE  
DISCOVERY OF DIAMONDS IN THE IRON.<sup>1</sup>

**HISTORICAL** Sketch of the Discovery.—In the latter part of March 1891 the mining firm of N. B. Booth and Co., of Albuquerque, New Mexico, received a letter

mined by a Colorado assayer, who reported "76·8 per cent. of iron, 1·8 per cent. lead,  $\frac{1}{2}$  ounce silver, and a trace of gold. From its appearance we should take it to be a furnace product."<sup>1</sup>

This result was naturally not satisfactory to the mining firm, and a mass weighing 40 pounds was broken into several fragments with a trip hammer. One of these was

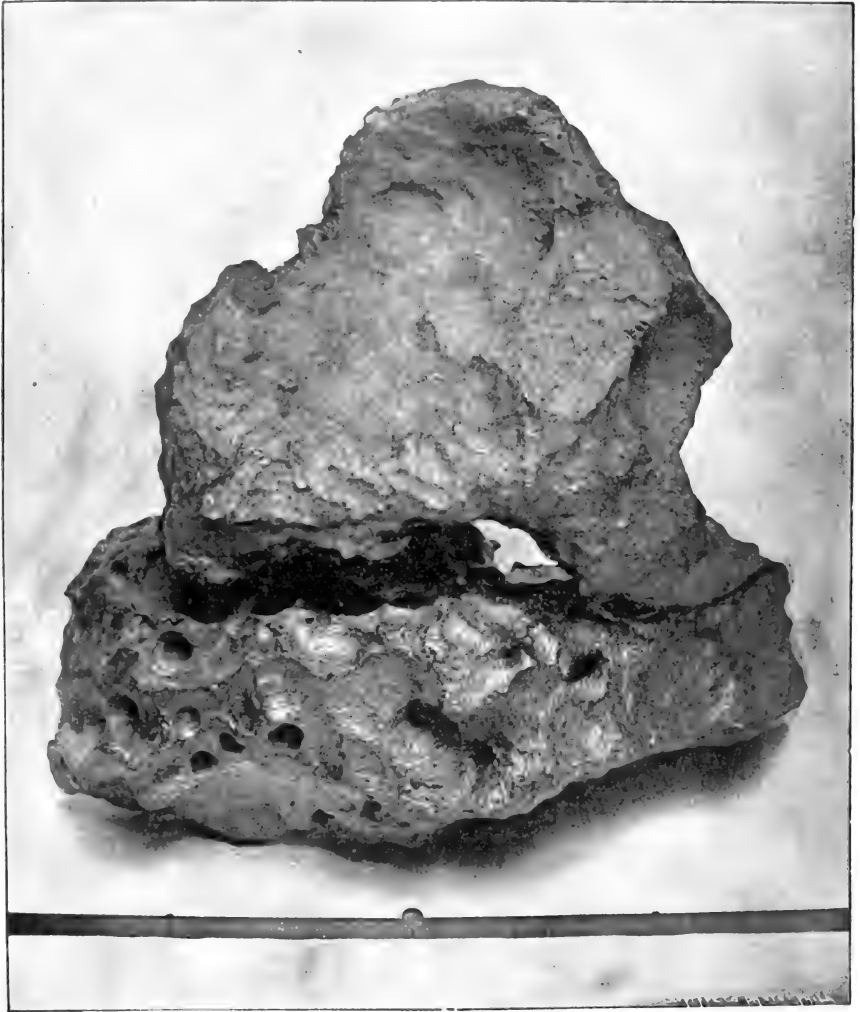

FIG. 1.—General appearance of meteorite.

from a prospector in Arizona informing them he had found a vein of metallic iron near Cañon Diablo, and sending them at the same time a piece with the request for an assay. Some time in April this piece was ex-

sent to the President of the Santa Fe Railroad, and another to General Williamson, the Land Commissioner of the Atlantic and Pacific Railroad Company, in Chicago.

<sup>1</sup> Read before the American Association for the Advancement of Science, by A. E. Foote, August 20, 1891. From the *American Journal of Science and Arts* for November 1891.

<sup>1</sup> This assay was of such a remarkable character that I took the trouble to stop at the city where it was made, and ask how such extraordinary results were obtained. I was informed that the lead, silver, and gold were probably the results of the materials used in making the assay.

General Williamson consulted me as to the probable value of the so-called mine of "pure metallic iron," stating, on the authority of the prospector, that the vein had been traced for a distance of about two miles, that it was 40 yards wide in places, finally disappearing into a mountain, and that a car-load could be taken from the surface and shipped with but little trouble.

A glance at the peculiar pitted appearance of the surface, and the remarkable crystalline structure of the fractured portion, convinced me that the fragment was part of a meteoric mass, and that the stories of the immense quantity were such as usually accompany the discovery of so-called native iron mines, or even meteoric stones. As soon as possible, in June, I made a visit to the locality, and found that the quantity had, as usual, been greatly exaggerated.

There were some remarkable mineralogical and geo-

bottom seemed to be from 50 to 100 feet (15·24 to 30·48 metres) below the surrounding plain. The rocks which form the rim of the so-called "crater" are sandstones and limestones, and are uplifted on all sides at an almost uniform angle of from 35° to 40°. A careful search, however, failed to reveal any lava, obsidian or other volcanic products. I am therefore unable to explain the cause of this remarkable geological phenomenon. I also regret that a severe gallop across the plain had put my photographic apparatus out of order, so that the plates I made were of no value.

About two miles (3·22 kilometres) from the point at the base of the "crater" in a nearly south-easterly direction, and almost exactly in a line with the longest dimensions of the area over which the fragments were found, two large masses were discovered within about 80 feet (24·38 metres) of each other. The area over which the small



FIG. 2.—Showing the polished surfaces.

logical features which, together with the character of the iron itself, would allow of a good deal of self-deception in a man who wanted to sell a mine.

*Description of Locality.*—Nearly all of the small fragments were found at a point about ten miles south-east from Cañon Diablo, near the base of a nearly circular elevation which is known locally as "Crater Mountain." I believe this is the same as Sunset Knoll, figured on the topographical sheets of the U.S. Geological Survey. This is 185 miles (297·72 kilometres) due north from Tucson, and about 250 miles (402·34 kilometres) west of Albuquerque.

The elevation, according to the Survey, rises 432 feet (131·67 metres) above the plain. Its centre is occupied by a cavity nearly three-quarters of a mile (1·2 kilometres) in diameter, the sides of which are so steep that animals that have descended into it have been unable to escape, and have left their bleached bones at the bottom. The

masses were scattered about one-third of a mile (0·53 kilometre) in length, and 120 feet (36·57 metres) in its widest part. The longer dimension extended north-west and south-east.

*Description of the Specimens.*—The largest mass discovered weighs 201 pounds (91·171 kilos), and, as the photograph shows (Fig. 1), has a somewhat flattened rectangular shape, showing extraordinarily deep and large pits, three of which pass entirely through the iron. The most remarkable example of such perforation is the Signet Iron from near Tucson, Arizona, now in the National Museum, and figured in Prof. F. W. Clarke's Catalogue.

<sup>1</sup> The Signet Iron was discovered about 30 miles (48·28 kilometres) from Tucson. Dr. Geo. H. Horn states that twenty-five years ago he was told by the Spaniards that plenty of iron could be found on a range of hills extending north-west and south-east half-way between Albuquerque and Tucson.

One other large mass was found weighing 154 pounds (69.853 kilos). This is also deeply pitted. A mass weighing approximately 40 pounds (18.144 kilos) was broken in pieces with a trip hammer, and it was in cutting one of the fragments of this mass that diamonds were discovered (Fig. 2).

Besides these masses of considerable size a careful search made by myself with the assistance of five men was rewarded by the discovery of 108 smaller masses. Twenty-three others were also discovered, making a total of 131 small masses, ranging in weight from  $\frac{1}{16}$  of an ounce (1.79 grm.) to 6 pounds 10 ounces (3.006 kilos).<sup>1</sup> A brownish-white, slightly botryoidal coating, found on a number of the meteorites, is probably aragonite.

A thorough examination of many miles of the plain proved that the car-load of iron existed only in imagination. Accompanying the pieces found at the base of the "crater" were oxidized and sulphuretted fragments which a preliminary examination has shown are undoubtedly of meteoric origin. About 200 pounds (90.718 kilos) of these were secured, from minute fragments up to 3 pounds 14 ounces (1.757 kilos). These fragments are mostly quite angular in character, and a very few show a greenish stain, resulting probably from the oxidation of the nickel. This oxidized material is identical in appearance with an incrustation which covers some of the iron masses and partially fills some of the pits.

*Composition.*—After obtaining the meteorite I was unable to return to Philadelphia for some time, and therefore sent a fragment of the 40-pound mass (18.144 kilos) to Prof. G. A. Koenig for examination. Prof. Koenig was compelled to leave town before this examination was completed. I take the following, therefore, from his letters to me, and from an account furnished the daily *Public Ledger* by Dr. E. J. Nolan, Secretary of the Academy of Sciences, of a preliminary notice made by Prof. Koenig, June 23, before the Academy of Natural Sciences of Philadelphia. In this account he says:—

"In cutting the meteoric iron for study it had been found of an extraordinary hardness, the section taking a day and a half, and a number of chisels having been destroyed in the process. When the mass, which on the exterior was not distinguished from other pieces of meteoric iron, was divided, it was found that the cutting apparatus had fortunately gone through a cavity. In the attempt to polish the surface, so as to bring out the characteristic Widmannstättian figures, Dr. Koenig received word that the emery wheel in use had been ruined.

"On examination, he then found that the exposed cavities contained diamonds which cut through polished corundum as easily as a knife will cut through gypsum. The diamonds exposed were small, black, and, of course, of but little commercial value, but mineralogically they are of the greatest interest, the presence of such in meteorites having been unknown until 1887, when two Russian mineralogists discovered traces of diamond in a meteoric mixture of olivine and bronzite. Granules of amorphous carbon were also found in the cavity, and a small quantity of this treated with acid had revealed a minute white diamond of one-half a millimetre, or about  $\frac{1}{50}$  of an inch in diameter. In manipulation, unfortunately, this specimen was lost, but others will doubtless be obtained in the course of investigation. The minerals troilite and daubreelite were also found in the cavities. The proportion of nickel in the general mass is 3 per cent., and the speaker was not as yet able to account for the extraordinary hardness apart from the presence of the diamonds in the cavities."

<sup>1</sup> October 18.—During September I received three additional large masses weighing respectively 632, 506, and 145 pounds (or 286.678, 229.516 and 65.771 kilos). The two latter were each perforated with three holes. A number of smaller masses up to 7 pounds (3.175 kilos) were discovered by digging. The three large masses and one of 23 pounds (10.430 kilos) were covered with grass and earth.—A. E. F.

Prof. Koenig in a letter to me gives the following points as definitely known:—

"(1) *Diamonds*, black and white, established by hardness and indifference to chemical agents. (2) *Carbon* in the form of a pulverulent iron carbide occurring in the same cavity with the diamonds. The precise nature of this carbide, whether containing hydrogen and nitrogen, is not ascertained, except in so far that after extracting all iron by nitro-hydrochloric acid the black residue goes into solution with deep brown colour upon treating it with potassium or sodium hydrate. From this solution acids do not precipitate anything. (3) *Sulphur* is not contained in the tough malleable portion of the meteorite, but in the pulverulent portion. (4) *Phosphorus* is contained in the latter, and not in the former. (5) *Nickel* and *Cobalt* in the proportion of 2:1 are contained in both parts nearly equally. (7) *Silicon* is only present in the pulverulent portion. (8) The Widmannstättian figures are not regular. (9) The iron is associated with a black hydroxide containing Fe, Ni, Co, P, in the ratio of the metallic part, and therefore presumably derived by a process of oxidation and hydration of the latter."

*Conclusions.*—As this meteoric iron contains only 3 per cent. of nickel, while that from the Santa Catarina Mountains, 30 miles (48.28 kilometres) south-east of Tucson and 215 miles (346 kilometres) from this locality, contains from 8 to 9 per cent., according to the analysis of Brush and Smith, they are quite distinct, although somewhat alike in external appearance. They also somewhat resemble the Glorieta meteoric irons from about 300 miles (482.8 kilometres) to the east-north-east, in New Mexico. These contain 11.15 per cent. of nickel.

The most interesting feature is the discovery for the first time of diamonds in meteoric iron.<sup>1</sup> This might have been predicted from the fact that all the constituents of meteoric iron have been found in meteoric stones, and *vice versa*, although in different proportions.

The incrustation of what is probably aragonite shown by some of the masses has rarely been noticed (I find two records by J. Lawrence Smith which he states to be unique, and both of these were from regions south of this one). The incrustation is especially interesting as showing that the meteoric irons must have been embedded a long time, as the formation of aragonite would be exceedingly slow in this dry climate.

The remarkable quantity of oxidized black fragmental material that was found at those points where the greatest number of small fragments of meteoric iron were found would seem to indicate that an extraordinarily large mass of probably 500 or 600 pounds (226.796 or 272.165 kilos) had become oxidized while passing through the air, and was so weakened in its internal structure that it had burst into pieces not long before reaching the earth.

#### THE SEVERE GALE OF NOVEMBER 11.

THE storm which traversed England on November 11 was one of the most severe of recent years. It resulted in considerable loss of life and property at sea on our coasts, and did a large amount of damage on land.

The weather over England at the commencement of the month was dry and fine, and the conditions were those known as anticyclonic, the barometer on November 5 having exceeded 30.7 inches over a great part of the United Kingdom. On November 8, the type of weather became cyclonic, and disturbances were skirting close to our coasts from off the Atlantic, south-westerly gales being experienced in the Hebrides and in the west of Ireland;

<sup>1</sup> Attention may be called to the discovery by Haidinger (1846) of cubic crystals of a graphitic carbon in the Arva meteoric iron, and also of somewhat similar crystals from the Youngdegen (West Australia) iron, described by Fletcher (1887) under the name of cliftonite. Both have been regarded as pseudomorphs after diamond.

whilst on the following day unsettled weather spread to other parts of the United Kingdom, and rain was heavy and persistent over the south of England.

The daily weather report issued by the Meteorological Office at 8 o'clock on the morning of the 10th showed that the winds were westerly and south-westerly over the whole of the British Islands under the influence of a storm area situated off the north-west of Scotland, the readings at our extreme northern stations being 29.1 inches; but a fresh fall of the barometer was already in progress at Valentia, and the wind had there backed to south-south-west. The report added: "The new depression which is approaching our western coasts is at present too far away to enable us to judge of its size or depth." The telegrams received by the Meteorological Office at 2 o'clock indicated the approach of a serious disturbance; the barometer was

Islands, and gales were blowing in most parts of the country. The cyclonic circulation of the winds was complete in our islands, the direction being northerly in Ireland, westerly and south-westerly over the Channel and the south of England, southerly on our east coasts, and easterly in Scotland and the northern portion of the Kingdom. The barometer gradients were very steep in the English Channel, as well as in the south-western and south-eastern districts; and at Scilly force 11 of Beaufort's notation was reported from the north-west. At many of the English stations the fall of the barometer since 6 o'clock the previous evening exceeded 0.9 inch, and at Hurst Castle it amounted to an inch, whilst in several places in the south and west the rainfall exceeded an inch in the preceding 24 hours. The gale continued to rage during the day, and at 2 o'clock in the afternoon the

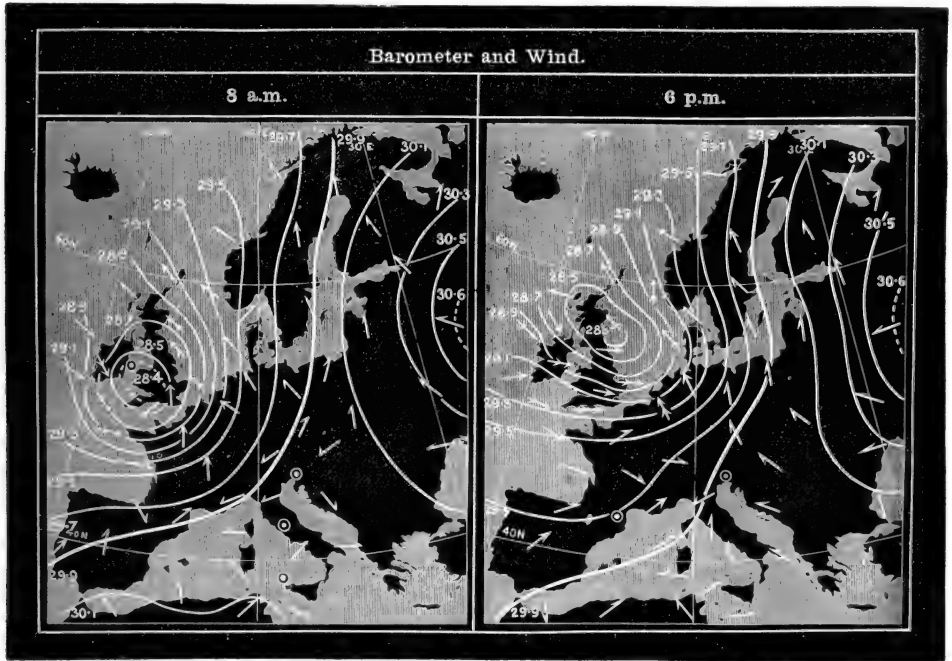

DIAGRAM TO ILLUSTRATE THE SEVERE GALE OF WEDNESDAY, NOVEMBER 11, 1891.

The barometer is expressed by isobars, the pressure corresponding to each line being given in inches and tenths. The winds are shown by arrows which are drawn flying with the wind.  $\odot$  = a calm;  $\rightarrow$  = a light or moderate wind;  $\rightarrow$  = a fresh or strong breeze;  $\rightarrow$  = a gale.

falling rapidly at the south-western stations, and the fall had now extended even to London, and the wind had backed over the whole Kingdom. The evening reports indicated a still further advance of the storm area towards our islands, and the trend of the isobars over the south-western portion of the Kingdom showed that the centre of the disturbance was not far distant to the south-westward, whilst moderate south-easterly gales were blowing at the entrance of the English Channel.

The conditions on the morning of the 11th are pictured in the diagram for 8 o'clock, obtained from the weekly weather report of the Meteorological Office, and from this it will be seen that the storm area was central over Pembrokeshire, the lowest reading being 28.36 inches at St. Ann's Head, whilst the mercury was below 29 inches over the entire area of the British

force of the wind at Dungeness was reported as 12 of Beaufort's notation, which is the extreme limit of the scale, and is equivalent to a hurricane, the lowest barometer reported to the Meteorological Office at this time being 28.34 inches at Shields. At 6 o'clock on the 11th, the central area of the storm had passed to the eastward of our coasts, as shown by the diagram for that hour, the core or heart of the storm not being far distant from Shields, where the barometer was standing at 28.31 inches, which is apparently the lowest reading recorded in the British Islands during the gale. Strong westerly and north-westerly gales were still blowing over the greater part of the United Kingdom, and the succeeding night was very boisterous, although the gale had everywhere subsided before 8 o'clock on the following morning.

The Meteorological Council have very kindly permitted the use of the Observatory records and other documents in their possession, which are more in detail than the eye observations made at the telegraphic reporting stations which furnish data for the daily weather reports.

The following table shows the hourly velocity of the wind as obtained from the anemometrical records. All velocities of 35 miles and upwards are given, and when so strong a wind is recorded at any Observatory, the velocity is given at the other Observatories, although less than 35 miles an hour.

*Velocity of the Wind by Anemographs.*

Time.	Valentia.	Falmouth.	Holyhead.	Kew.	Aberdeen.
November 11.					
1 a.m.	28	28	41	25	16
2 "	34	31	41	27	21
3 "	37	24	38	26	20
4 "	41	23	33	20	27
5 "	39	21	31	28	34
6 "	38	21	20	34	35
7 "	34	25	13	31	37
8 "	32	50	2	31	40
9 "	34	62	17	32	44
10 "	33	56	36	35	47
11 "	28	51	57	30	43
Noon.	33	43	59	25	44
1 p.m.	35	43	58	32	41
2 "	34	34	52	45	39
3 "	34	30	43	43	39
4 "	32	33	48	35	36
5 "	24	20	48	29	30
6 "	17	24	42	29	21
7 "	17	20	46	29	22
8 "	20	18	39	26	17
9 "	15	16	46	21	11
10 "	18	12	42	17	13
11 "	27	11	40	12	22
Midnight.	20	16	36	15	23

From the table it will be seen that the gale did not continue over the United Kingdom for more than twenty-four hours, and at Falmouth and Holyhead, where the highest velocities were obtained, the wind only exceeded 50 miles an hour—a fresh gale of Beaufort's notation—for four hours; whilst the maximum hourly velocity at any observatory was 62 miles, registered at Falmouth at 9 o'clock in the morning. These velocities, although a fair index of the severity of the gale, give no idea of the violence of the gusts or squalls.

The photographic registrations of the barometer show that at Valentia the first fall for the gale set in at 1 a.m., 10th, when the mercury was standing at 29.5 inches, and the lowest reading was not reached for more than twenty-four hours later, the minimum being 28.78 inches at 2.10 a.m., 11th. The fall at Valentia only exceeded the rate of 0.05 inch per hour for two hours, and the subsequent rise there was not very brisk; the wind force, however, at Valentia throughout the storm did not exceed a moderate gale. At Falmouth, the barometer commenced to fall at 8 a.m., 10th, and by 1 a.m., 11th, the mercury had decreased an inch, whilst the lowest reading was 28.37 inches at 5 a.m., 11th. The subsequent rise was very slight at first, but after 8 a.m., 11th, it amounted to 0.15 inch per hour. At Kew the first fall of the barometer is shown at 11 a.m., 10th, just ten hours subsequent to Valentia; and the lowest reading was 28.47 inches at 11.5 a.m., 11th, only nine hours later than Valentia. The fall did not amount to 0.1 inch per hour, but the subsequent rise was 0.15 inch per hour from 1 to 3 p.m. The wind did not veer till after 1 p.m., and then only to west-south-west from south-south-west. The hourly velocity of the wind at Kew evidently affords but little illustration of the violence of the gale, since the maximum velocity was

only 45 miles, which occurred at 2 p.m.; whilst at Greenwich the pressure anemometer registered 31.5 lbs. on the square foot at 2.35 p.m. At Fort William the barometer commenced to fall at 11.30 a.m., 10th, and the lowest reading was 28.48 inches at 3.53 p.m., 11th. At Aberdeen the fall of the barometer set in at 7.45 p.m., 10th, and the minimum was 28.38 inches at 9 p.m., 11th; whilst here the wind changed suddenly from south-east by east to west by north at 10.15 p.m., 11th.

The ship *Khyber*, Captain W. Peterkin, keeping a log for the Meteorological Office, felt the first influence of the cyclonic weather system at midnight, 9th, in lat. 49° 30' N., and long. 13° W., about 300 miles to the west of Land's End, when a moderate south-west wind was blowing, and the barometer stood at 29.64 inches. The wind afterwards changed through south, south-east, east, and north-east, and the centre of the disturbance passed to the south of the vessel, being nearest to the ship at about 10 p.m., 10th, when the barometer was 28.71 inches, and the wind was blowing a fresh gale from north-north-east, the ship being in lat. 49° 40' N., and long. 12° 20' W. This vessel shows that the wind did not attain gale force until after the centre had passed to the east of the ship, but with a rising barometer she experienced a very strong northerly gale.

The observations from the *Khyber*, considered with those obtained from stations in the United Kingdom, show that the storm system travelled across the area of the British Islands at the rate of about 34 English miles per hour; but the rate of progress was slackening decidedly after it had passed over the centre of England, and on reaching the North Sea it passed away very slowly to the northward.

The exceptional features of the storm were the strong gales experienced in the English Channel and over the southern portion of the Kingdom, accompanied by a terrific sea, the latter being doubtless greatly aggravated owing to the heavy westerly wind setting up the Channel, also the low barometer which occurred in the southern part of the country. In the neighbourhood of London the barometer fell to 28.47 inches, and there have only been seven years since 1811 in which the reading has fallen lower, the absolutely lowest corrected reading during the last eighty years in the vicinity of London being 28.02 inches on January 29, 1814.

The influence of this storm area had not passed away from our islands before an entirely fresh disturbance was seen to be approaching the Irish coasts, and at Valentia a fresh fall of the barometer was in progress after 7.50 p.m. on the 11th, the barometer having only previously risen to 29.20 inches. The mercury subsequently fell to 28.36 inches at 6.20 p.m., 12th, which is more than 0.4 inches lower than during the gale of the 11th; and the wind attained the velocity of 58 miles an hour, and was above 50 miles an hour for ten hours, from 1 to 10 p.m. At Falmouth the wind attained the hourly velocity of 47 miles at 6 p.m., 12th, and at Holyhead 45 miles at noon, 12th; but at Kew and Aberdeen the wind did not increase beyond a fresh breeze.

The sudden manner in which this second disturbance collapsed, after assuming very threatening proportions, is of considerable interest, in so far as it affords a good illustration of the extreme difficulty experienced at times in the weather forecasting for our islands; the present position of science affording no explanation why the one storm should traverse our islands, and the other prove entirely abortive after reaching the western stations.

CHAS. HARDING.

#### NOTES.

THE Duke of Devonshire, of whose death every one was sorry to hear, maintained throughout life the interest in science which had been fostered by his studies as an undergraduate at



Cambridge, where he distinguished himself equally in mathematics and in classics. He acted as Chairman of the Royal Commission on Scientific Instruction and the Advancement of Science, whose reports might have marked an era in our national progress if there had been a scientific department of the Government to give effect to them. At Cambridge he did what he could to encourage scientific study by his splendid gift of the Cavendish Laboratory. The Duke was the first President of the Iron and Steel Institute; and the Owens College, Manchester, owed much to the zeal and liberality with which, on every suitable occasion, he sought to promote its interests.

MR. E. RAY LANKESTER, Deputy-Professor of Human and Comparative Anatomy, has been elected to the Linacre Professorship of Human and Comparative Anatomy, Oxford, vacated by the death of Prof. Moseley.

PROF. MARSHALL WARD has been engaged lately in studying the strange compound organism called by villagers the "ginger-beer plant." We print elsewhere an abstract of an interesting paper in which he submitted his results to the Royal Society last week.

AT the annual meeting of the Academy of Medicine of Paris, on the 15th instant, the Alvarenga Prize, which is given annually for the best treatise on some medical subject, was awarded to Dr. Bateman, of Norwich, for his work on aphasia, and to Dr. Legneu, of Paris, for his treatise on renal calculi, these gentlemen being bracketed together *ex æquo*. This prize confers the title of Laureate of the Academy.

THE "Committee of Council on Education" have sanctioned the appointment of Mr. George Brebner as first Marshall Scholar in Biology at the Royal College of Science, London. Mr. Brebner has passed through both the botanical and zoological advanced classes of the Biological Division in the Royal College, and in 1889 obtained the Edward Forbes Medal and Prize awarded to the best student of the year in biology. Mr. Brebner has already been engaged in botanical research, and has published two original papers on structural subjects, in conjunction with Dr. D. H. Scott. He has also assisted Dr. E. Schunck, F.R.S., of Manchester, in his investigations of the chemistry of chlorophyll, and is about to publish a joint paper with him. Mr. Brebner's researches as Marshall Scholar will be carried on in the Huxley Research Laboratory, and will be concerned with questions relating to the histology of plants.

THE Paris Museum of Natural History has been partly reorganized by a recent decree. The financial management is changed; and it has been decided that the Professors shall, as a rule, retire from their Professorships at seventy-five years of age. To this rule, however, there are to be exceptions. An exceptional case is that of M. de Quatrefages, who retains his post, although Profs. Fremy and Daubrée will have to retire. The name of "aide-naturaliste" disappears, and that of "assistant" takes its place—a fact which is rather curious, since "assistant," in French, has not the same meaning as in English, or as the corresponding word has in German. The assistants are empowered, under some limitations, to deliver courses of lectures, and their financial position is to be improved.

THE Royal Geographical Society is to be congratulated on the success of its system for the proper spelling of geographical names. When its rules on the subject were drawn up, it was not anticipated that foreign nations would make any change in the form of orthography used in their maps. As a matter of fact, however, considerable changes are being effected. In the circular letter, the principal passages of which we print elsewhere, it is noted as a most satisfactory piece of news that France and Germany have both promulgated systems of ortho-

graphy for foreign words, which in many details agree with the English system.

AN Italian correspondent of the *Lancet* writes that on December 10 the academic world of Rome entertained at a banquet the Senator Stanislao Cannizzaro, in celebration of the bestowal on him of the Copley Medal by the Royal Society of London. The Accademia dei Lincei (the "Royal Society" of Rome), the Accademia di Medicina, and the Senatus Academicus of the "Sapienza" were fully represented on the occasion. The Chairman was the eminent mathematician and engineer, the Senator Brioschi, who, in a few felicitously chosen sentences, conveyed the sense of pride shared by all Italians at the bestowal on their compatriot of the "blue ribbon" of science. Signor Villari, Minister of Public Instruction, also spoke. The Senator Todaro, the Professor of Anatomy in the University, gave the toast of "The Royal Society of London," which was as cordially received as it was eloquently proposed. Prof. Cannizzaro thereafter delivered an effective speech, in which he showed that it was in the effort to make his prelections clear to successive generations of students that he had trained himself to reach those laws, the co-ordination of which had won for him the recognition of the greatest court of scientific arbitration in the world.

ACCORDING to a despatch from Philadelphia, published in the *New York Sun*, it has been decided that an Expedition shall be sent to Greenland for the relief of Lieutenant Peary and his party. Dr. Keeley, who accompanied Lieutenant Peary on his exploring expedition, but afterwards returned, has said that, unless such an Expedition, fully equipped for an Arctic season, were sent to his assistance, Lieutenant Peary and his companions would never reach the bounds of civilization.

MR. RICHARD BOXALL GRANTHAM, who died lately in his eighty-sixth year, was one of the engineers who helped Brunel in the construction of the Great Western Railway. He made the branch line from Gloucester to Cheltenham. He was an authority on sanitary matters, and in 1869 became Chairman of the Committee appointed by the British Association to inquire into the treatment and utilization of sewage. In 1876 he successfully completed the reclamation of Brading Harbour, in the Isle of Wight. This had been attempted by Sir Hugh Middleton 250 years previously, but his work had afterwards been destroyed by the sea.

DUTCH newspapers announce the temporary nomination of Mr. E. Engelenburg, meteorologist at the Royal Meteorological Institution at Utrecht, as Director of the Observations on land. This directorship had become vacant by the appointment of Dr. M. Snellen to the position of Chief Director of the same Institution, which had been held by the late Prof. Buys Ballot. Mr. Engelenburg accompanied Dr. E. van Rÿckevorsel to Brazil, acted as his assistant during the magnetic survey of that country, 1882-85, and prepared a part of the report on this survey published in 1890 by the Royal Academy of Sciences at Amsterdam. In 1887 he was attached by Prof. Buys Ballot to the Meteorological Institution, and has since been responsible for the yearly report on the thunderstorms observed in the Netherlands, formerly prepared by Dr. Snellen. He has also investigated the quantities of rain in different parts of the Netherlands and in the different months of the year. His results on this subject have lately been published in the *Memoirs of the Royal Academy of Sciences at Amsterdam*; the accompanying rain-maps give a clear idea of the dependence of the rainfall on the distance from the seashore. He has repeatedly directed his attention to the tides at the coast of the Netherlands; to the variation of the velocity of the tidal currents in the Dutch "seegaten," i.e. the entrances to the Dutch roads or harbours (*de Ingenieur*,

Nos. 5, 9, and 38, of the year 1889); and to the influence of the wind and atmospheric pressure on the height of the sea-surface (*de Ingenieur*, 1891, No. 39).

THE Annual Meteorological Report for Japan for 1889, recently received in this country, shows that considerable attention is given to the subject of meteorology, and contains the results of the hourly observations or continuous records for Tokio, together with observations taken simultaneously at the top and base of Mount Fuji, the highest mountain in Japan. The observations on the mountain were made at a height of about 12,250 feet, during 38 days from August 1 to September 7, 1889. Twice during this period the anemometer was broken by the force of the storms. The position of this station—an extinct volcano, near the Pacific—renders it very important for the investigation of the meteorology of high regions. On this account it has several times been used for that purpose, but the observations have previously all been confined to a few consecutive days.

On December 18, at 7.30 a.m., a violent earthquake shock was felt at Corleone, an inland town in the province of Palermo, Sicily. The first shock was followed by a pronounced undulatory movement in the direction of north to south.

MR. G. A. NUSSBAUM, agent in London for the Société Générale des Téléphones, Paris, informs us that he has lately made a complete telephone installation at the Adelphi Hotel, Liverpool. The installation comprises three floors, and on each floor a switch board for seventy directions is fitted, the total number of stations being 210. Visitors are thus enabled to communicate with one another, but it seems somewhat doubtful whether they will all be quite pleased to find this sort of thing in their bedrooms.

An interesting paper on electricity in relation to mining, by Mr. Ernest Scott, was read before the Institution of Engineers and Shipbuilders in Scotland on November 24, and is now printed in the Institution's Transactions. About fifty mines in the United Kingdom are already supplied with electricity, and the new methods are not unlikely, he thinks, to effect "a small revolution in the mining industry." Mines which have been commercially unworkable owing to their depth, or the great distance of the working face from the pit-head, may now be turned into profitable undertakings. Mr. Scott notes that electric power can claim the following advantages over steam, hydraulic, and compressed air: (1) greater efficiency, and therefore reduced first cost and expenses in working, than other mediums of power transmission over considerable distances—say above half a mile; (2) the greater ease with which the comparatively small copper conductors can be manipulated and kept in order as compared with piping, especially where there are falling roofs or shifting floors; (3) the facility with which machines which require to be moved occasionally—*e.g.* coal-cutters, pumps, &c.—can be advanced along the roadways as the work proceeds, or taken about on bogey carriages from one part of the workings to another.

At the meeting of the Society of Arts on December 16, General Pitt-Rivers delivered a capital lecture on typological museums, as exemplified by the Pitt-Rivers Museum at Oxford, and his provincial museum at Farnham, Dorset. The lecture is printed in the current number of the Society's Journal. By "typological museums," General Pitt-Rivers means museums in which objects are arranged in a way that brings out the sequence of types. Museums of this kind are, he thinks, best suited for educational purposes; and he urged strongly that many of them should be established. The museum he has formed at Farnham has been greatly appreciated; and he believes that in some respects it is even better than the institution which bears his name at Oxford, because such series

as it contains are more fully represented. Among the speakers after the delivery of the lecture, was Dr. E. B. Tylor, who gave a striking instance of the value of the principle on which the objects in the Pitt-Rivers Museum are arranged. It often happened, he said, that a series might be made purely theoretical, by putting in their order a number of specimens which referred to one another more or less distinctly, thus showing where the curve of development had probably passed; but yet important links were often wanting, and the visitor went away possessed with the desire to find those links and present them to the Museum. Only a few weeks ago they thus acquired a much-desired link in the history of stringed instruments. The late Mr. Carl Engel suggested that the string bow must have been the origin of the whole series of stringed instruments, whether pianoforte, violin, or guitar. This view was proved to be correct when the instruments were arranged in a series, beginning with a string bow. The difficulty, however, was to get the starting-point—an authentic bow capable of being used both for hunting and twanging. One people who were described as using the bow for this double purpose were the Damaras; it was said that the hunter shot game with his bow during the day, and when he came home sat by the fire and amused himself by twanging the string. Three or four weeks ago Miss Lloyd, who had spent some time in South Africa, sent them one of these bows, and it now stood at the head of the series of stringed instruments.

THE Indian Bureau of the U.S. Government propose to have at the Chicago Exposition an interesting exhibit, which will perhaps occupy two acres. Representatives of all the leading Indian tribes, especially those of a distinctive type, will be shown, together with their habitations, industries, &c. The Navajos will display their skill in blanket-weaving; the Zuñis, who will live in a "hogan," as they call their dwellings, will make pottery; the Piutes are to make water-bottles of rushes. There will be a great collection of relics, weapons, and utensils; and it is intended that competent teachers shall carry on their work in a model Indian school. Visitors will have ample opportunities of comparing the aborigines in their wild state with the civilized or semi-civilized Indians of to-day.

ACCORDING to official returns, lately reviewed by the *Adelaide Observer*, the area of land devoted in South Australia to gardens and orchards has advanced since 1885 from 10,775 acres to 15,362 acres, representing an increase of 50 per cent., this area apparently including that devoted to viticulture. The statistics show that the orange, almond, walnut, chestnut, and olive are largely cultivated. The number of almond trees is given as 134,038, or 27,768 more than last year; olive trees, 59,118, or 11,694 more; and orange trees, 56,341, the latter producing 44,762 cases of fruit, or 3040 more. The increase in the manufacture of olive oil is even more marked. The quantity made is returned at 6838 gallons, as against 1486 in the previous year. Almond trees are stated to have produced 3311 cwt. of nuts, being an increase of 1468 cwt. In 1890 walnut trees numbered 7644, and chestnut trees 1128. The climate and flora of South Australia are also well adapted to the needs of the bee-keeper. According to the rough estimates of the bee-owners, 25,383 hives in the colony last year produced nearly 500 tons of honey, of which 80,793 pounds were exported.

TOWARDS the end of last March the citizens of Sydney were astonished by the sudden discoloration of the water in Port Jackson. In the harbour the water presented in many places the appearance of blood. This remarkable phenomenon, which was soon found to be due to the presence of a minute organism, has been made the subject of a paper, by Mr. Thomas Whitelegge, in the Records of the Australian Museum (vol. i. No. 9). On March 31, Mr. Whitelegge went to Dawe's Point, and got a

bottle of water, in which there was a good supply of the organism in question. At first he thought it was a species of the genus *Peridiniæ*; but further research convinced him that it was a new species of the closely allied genus, *Glenodinium*. So far as Mr. Whitelegge is able to judge, fully one-half of the shore fauna must have been destroyed by these small invaders. The bivalves were almost exterminated in those localities where the organism was abundant during the whole of the visitation. Mr. Whitelegge is of opinion that the great destruction of life brought about by an organism apparently so insignificant is of the highest interest from a biological point of view, showing, as it does, how limited is our knowledge of the causes which influence marine food-supplies. This, he points out, is particularly the case in regard to the oyster, which has often mysteriously disappeared from localities where it formerly abounded.

THE U.S. Department of Agriculture has published the fifth number of a series of papers on the North American fauna. The number contains the results of a "biological reconnaissance" of a part of Idaho, which Dr. C. Hart Merriam conducted during August, September, and October 1890; and also descriptions of a new genus and several new species of North American mammals. The new genus (*Microdipodops*) is a kind of dwarf kangaroo rat from Nevada. Dr. Merriam speaks of this as one of the most remarkable of the many new and interesting mammals discovered in North America during the past few years. Six specimens were collected in Nevada by Mr. Bailey in October and November 1890.

It is most important that members of the medical and scholastic professions, and the public generally, should have sound ideas on the best means for guarding great educational establishments from the outbreak and spread of preventable infectious and contagious disease. We are glad to note, therefore, that the code of rules on the subject, drawn up by the Medical Officers of Schools Association, has been so much in demand that it has been necessary for Messrs. J. and A. Churchill, the publishers, to issue a third edition. An important note to an appendix in which disinfection is dealt with has been added in this edition. The measures indicated in the appendix have hitherto been regarded as at least serviceable for the attainment of disinfection. Recent experiments, however, seem to show that none of them can be relied upon as absolutely effectual in certain cases.

AT the meeting of the Field Naturalists' Club of Victoria, on October 12, Mr. J. P. Eckert read a paper on "some peculiar changes in the colour of the flower of *Swainsonia procumbens*." When the flower opens, the corolla is lilac, and the first change is noticed in the longitudinal venules of the largest petals, which soon after assume a deep crimson. Then, at two different points of the petals a dark blue is noticed, which gradually extends over the whole surface, the peripheral portion being a little paler in colour. In the central portion the colour varies through all the shades of blue till finally it assumes a rosy tint. Frequently the petals will assume their original colour for some days, and afterwards go through all the gradations of colour once more. Mr. Eckert assigns the phenomena to a meteorological cause, and claims that his theory is supported by experiments with the electric current.

THE New York *Engineering News* says that prehistoric irrigation canals in Arizona are "really worthy of more notice than is usually given them. The Salt and Gila River valleys are intersected by a vast network of these canals, which antedate, at least, the arrival of Coronado in 1552, for he mentions these ruins and the traditions of the Indians regarding a once dense population in this region. Modern engineers cannot improve upon the lines of these canals, nor in the selection of points of

diversion from the rivers. The first irrigation canal in this section, the one that has made Phoenix, with its present population of 20,000, simply followed the lines of one of these old canals. Their extent may be appreciated when it is said that in the Salt River valley alone the land covered by these canals once aggregated over 250,000 acres, and the canals themselves, with their laterals, must have exceeded 1000 miles in length. This country is filled with prehistoric ruins, with walls of stone or adobe, and almost every acre contains fragments of pottery, steel ornaments, stone implements, and other remains of a population which can only be estimated in its aggregate."

THE fifth part of "Bibliotheca Mathematica," edited by G. Eneström (Stockholm), is devoted to a bibliography of the history of the mathematical sciences in the Netherlands, by D. Biersen de Haan, of Leyden. By the conditions of the publication the writer is restricted "aux écrits se rapportant exclusivement ou au moins essentiellement à l'histoire des mathématiques pures." In ten octavo pages the list ranges from 1667 to the present time, and contains sixty entries, the compiler being credited with thirteen of them. There is also a long list of *Hogers* on Dutch mathematicians.

WE have received from Mr. Elliot Stock the second volume of *The Field Club*. It is a magazine of general natural history, and cannot fail to give pleasure to readers who are interested in the results of scientific observation. The editor is the Rev. Theodore Wood.

THE new number of the *Economic Journal* (vol. i. No. 4) deals with various questions which are of great scientific interest as well as of urgent public importance. It opens with an introductory lecture on political economy, by Prof. F. Y. Edgeworth, the editor. Then come papers on the alleged differences in the wages of men and women, by Sidney Webb; the coal question, by Forster Brown; the new theory of interest, by W. Smart; the evolution of the Socialist programme in Germany, by Prof. G. Adler; labour troubles in New Zealand, by W. T. Charlewood; and an attempt to estimate the circulation of the rupee, by F. C. Harrison.

THE January number of *Mind*, the first of the new series, will contain articles by Mr. W. E. Johnson on "Symbolic Logic," by Mr. Alexander on the "Idea of Value," by Mr. McTaggart on the "Change of Method in Hegel's Dialectic," and by Prof. Lloyd Morgan on the "Law of Psychogenesis."

THE arrangements for science lectures at the Royal Victoria Hall during January are as follows:—January 12, Sir Herbert C. Perrott (Chief Secretary of the St. John's Ambulance Association), "First Aid to the Injured: its object, origin, and development" (this lecture will be followed by an ambulance class in the Morley Memorial College); 19, Mr. Locke Worthington, "Egypt 3000 years ago." On the 26th, Prof. Reinold will deliver a lecture.

TWO new methods of preparing free solid hydroxylamine,  $\text{NH}_2\text{OH}$ , are described by M. Crismer in the current number of the *Bulletin de la Société Chimique*. It will be remembered that this important substance was isolated a few weeks ago by M. Lobry de Bruyn; an account of the manner in which it was obtained, together with a description of the dangerous properties of the free base, was given in NATURE (p. 20). M. Crismer now publishes two very simple methods of isolating anhydrous hydroxylamine, by the use of a compound of hydroxylamine and zinc chloride, previously described by him (comp. NATURE, vol. xli. p. 401). This interesting compound is a crystalline substance, of the composition  $\text{ZnCl}_2 \cdot 2\text{NH}_2\text{OH}$ , readily prepared in large quantity by dissolving the hydrochloride of

## OUR ASTRONOMICAL COLUMN.

hydroxylamine,  $\text{NH}_2\text{OH} \cdot \text{HCl}$ , in alcohol, in a flask provided with an inverted condenser, adding the requisite quantity of zinc oxide, and boiling the liquid until it is quite clear. Upon cooling, crystals of the compound are deposited. These crystals are very permanent in their behaviour towards solvents; they resist organic solvents completely, and are only slightly attacked by water. They are rendered much more unstable by rise of temperature, and explode most violently when an attempt is made to fuse them. If, however, they are carefully warmed up to  $120^\circ$  in a flask connected with a series of U-tubes, they dissociate regularly, a gas being rapidly evolved, which condenses to a liquid, mainly in the first U-tube. This liquid is very rich in hydroxylamine, but owing to the dehydrating action of the zinc chloride, contains small quantities of decomposition products. This destructive action of the zinc chloride may be altogether avoided, however, if another base capable of replacing the hydroxylamine in the compound is present during the distillation. The base which M. Crismer finds most effective is aniline. About ten grams of the zinc salt are added to twenty cubic centimetres of freshly distilled aniline, and the mixture is submitted to distillation under reduced pressure. Under these circumstances a liquid of very high refractive power distils over. In a few minutes this liquid commences to crystallize in large colourless lamelle, and upon surrounding the receiver with iced-water the whole completely crystallizes. These crystals, when washed with a little ether to remove a trace of aniline which is mechanically carried over, are found to correspond to the formula  $\text{NH}_2\text{OH}$ . They are identical in all respects with those described by M. Lobry de Bruyn. They dissolve in all proportions in water, and the solution possesses the ordinary properties of aqueous hydroxylamine. The crystals are very deliquescent, attracting moisture with the utmost avidity. They melt at the temperature of the hand. The compound of zinc chloride and aniline, which remains in the distillation flask, may be obtained from solution in boiling alcohol in minute snow-white crystals.

The second method by which anhydrous hydroxylamine may be prepared consists in passing dry ammonia gas into an emulsion of the zinc compound  $\text{ZnCl}_2 \cdot 2\text{NH}_2\text{OH}$  in absolute ether. As soon as the first bubbles of ammonia enter the flask an energetic reaction occurs, the zinc salt swells up rapidly, and eventually the whole of the hydroxylamine is liberated, and is dissolved by the ether. The clear ethereal solution is subsequently decanted, and the ether removed by distillation *in vacuo*, when white crystals of hydroxylamine remain in the vessel in which the distillation is carried out. The only precaution necessary in adopting this mode of preparation is to employ a tolerably large proportion of ether, as hydroxylamine does not dissolve in that liquid to a very large extent. M. Crismer finds it most convenient to perform the experiment in an apparatus so constructed that the extraction by ether of the product of the action of ammonia is continuous.

The additions to the Zoological Society's Gardens during the past week include three Rhesus Monkeys (*Macacus rhesus* ♂ ♂ ♀) from India, presented respectively by Dr. Hewetson, Mr. H. Godfrey, and Mr. W. A. Morgan; a Puma (*Felis concolor*) from Sante Fe, Argentine Republic, presented by Mr. Thos. Bowers; a Musanga Paradoxure (*Paradoxurus musanga*) from the Indian Archipelago, presented by Mr. J. Watson; a Grey Ichneumon (*Herpestes griseus*) from India, presented by Mr. W. Needham; and an Azara's Agouti (*Dasyprocta azarae*) from British Guiana, presented by Mr. R. Scott-Brass; a Northern Mocking Bird (*Mimus polyglottus*) from North America, presented by Major N. Gosselin; two Brown Hyænas (*Hyæna brunnea* ♂ ♀) from South Africa, a Two-toed Sloth (*Choloepus didactylus*) from Demerara, purchased.

NO. 1156, VOL. 45]

CAPTURE OF COMETS BY PLANETS.—During the last two or three years several astronomers have studied the action of planets in changing the orbits of comets which pass near them, and a considerable amount of interest has been aroused in this problem. Prof. H. A. Newton, in the *American Journal of Science* for September and December, establishes a number of propositions relative to the perturbations by planets which lead to the annexation of comets. Some of the results obtained may be expressed as follows:—(1) If a comet passes in front of Jupiter, the kinetic energy of the comet is diminished; if it passes behind the planet, the kinetic energy of the comet is increased. (2) The greatest effect of perturbation of a planet moving in a circular orbit in shortening the periodic time of a comet originally moving in a parabola is obtained if the comet's original orbit actually intersects the planet's orbit at an angle of  $45^\circ$ , and if the comet is due first at the point of intersection, at the instant when the planet's distance therefrom is equal to the planet's distance from the sun multiplied by the ratio of the mass of the planet to the mass of the sun. (3) If in a given period of time 1,000,000,000 comets come in parabolic orbits nearer to the sun than Jupiter, 126 of them will have their orbits changed into ellipses with periodic times less than one-half that of Jupiter; 839 of them will have their orbits changed into ellipses with periodic times less than that of Jupiter; 1701 of them will have their orbits changed into ellipses with periodic times less than one and a half times that of Jupiter; and 2670 of them will have their orbits changed into ellipses with periodic times less than twice that of Jupiter. (4) Of the 839 comets which are reduced to have periodic times less than Jupiter's period, 203 will, after perturbation, have retrograde motions, and 639 will have direct motions. (5) Somewhat more than five times as many of these comets move in direct orbits inclined less than  $30^\circ$  to Jupiter's orbit as move in retrograde orbits inclined less than  $30^\circ$  to Jupiter's orbit. It may therefore be said that comets which are changed by the perturbing action of a planet from parabolic orbits of every possible inclination to the ecliptic into short period ellipses must, as a rule, move in orbits of moderate inclination, and with direct motions.

LAW OF LIMITING APERTURES.—The results of some interesting photometric experiments connected with the application of the law of limiting apertures to small object-glasses are given by Dr. E. J. Spitta in *Monthly Notices R.A.S.*, November 1891. The apertures of six object-glasses were reduced to one-half and one-quarter respectively, and the intensity of a point at the focus of each was then photometrically tested. The numbers obtained were in neither case proportional to the square of the linear aperture of the object-glass, and they indicated that the outer zones do not contribute as much to the intensity of the image at the focus as they should do theoretically. Some photometric observations by Dr. Müller, of Potsdam, also show that the brilliancy of the focal image is only very slightly affected by blotting out the outer parts of his object-glass; the observed and computed intensities being very discordant until the diameter had been diminished to about one-half. Dr. Spitta believes that the cause of the difference lies in the admixtation of the glasses used.

CONNAISSANCE DES TEMPS for 1893, and the extract from the one for 1892, containing information useful for mariners, have just been received from the Bureau des Longitudes. The arrangement appears to be the same as usual, and no comment as to its excellence is needed.

## ORTHOGRAPHY OF GEOGRAPHICAL NAMES.

THE Council of the Royal Geographical Society have just issued a circular letter, signed by Sir M. E. Grant Duff, the President of the Society, on this important subject. The following are its principal passages:—

In 1885 the Council, impressed with the necessity of endeavouring to reduce the confusion existing in British maps with regard to the spelling of geographical names, in consequence of the variety of systems of orthography used by travellers and others to represent the sound of native place-names in different parts of the world, formally adopted the general principle which had been long used by many, and the recognition of which had been steadily gaining ground, viz. that in writing geographical native

names vowels should have their Italian significance, and consonants that which they have in the English language.

This broad principle required elucidation in its details, and a system based upon it was consequently drawn up with the intention of representing the principal syllabic sounds. The object aimed at was to provide a system which should be simple enough for any educated person to master with the minimum of trouble, and which at the same time would afford an approximation to the sound of a place-name such as a native might recognize. No attempt was made to represent the numberless delicate inflexions of sound and tone which belong to every language, often to different dialects of the same language. For it was felt not only that such a task would be impossible, but that an attempt to provide for such niceties would defeat the object.

The adoption by others of the system thus settled has been more general than the Council ventured to hope. The charts and maps issued by the Admiralty and War Office have been, since 1885, compiled and extensively revised in accordance with it. The Foreign and Colonial Offices have accepted it, and the latter has communicated with the colonies, requesting them to carry it out in respect to names of native origin. Even more important, however, than these adhesions is the recent action of the Government of the United States of America, which, after an exhaustive inquiry, has adopted a system in close conformity with that of the Royal Geographical Society, and has directed that the spelling of all names in their vast territories should, in cases where the orthography is at present doubtful, be settled authoritatively by a committee appointed for the purpose. The two great English-speaking nations are thus working in harmony.

The Council, by printing the rules in "Hints to Travellers," and by other means, have endeavoured to insure that all travellers connected with the Society should be made aware of them; but as it is possible that some bodies and persons interested in the question may still be in ignorance of their existence and general acceptance, they feel that the time has come to again publish them as widely as possible, and to take every means in their power to aid the progress of the reform.

To this end, and with a view to still closer uniformity in geographical nomenclature in revisions of editions of published maps, a gigantic task requiring many years to carry out, the Council have decided to take steps to commence tentatively indexes of a few regions, in which the place-names will be recorded in the accepted form.

RULES.

The rules referred to are as follows:—

1. No change is made in the orthography of foreign names in countries which use Roman letters: thus Spanish, Portuguese, Dutch, &c., names will be spelt as by the respective nations.

2. Neither is change made in the spelling of such names in languages which are not written in Roman character as have become by long usage familiar to English readers: thus Calcutta, Cutch, Celebes, Mecca, &c., will be retained in their present form.

3. The true sound of the word as locally pronounced will be taken as the basis of the spelling.

4. An approximation, however, to the sound is alone aimed at. A system which would attempt to represent the more delicate inflexions of sound and accent would be so complicated as only to defeat itself. Those who desire a more accurate pronunciation of the written name must learn it on the spot by a study of local accent and peculiarities.

5. The broad features of the system are:—

(a) That vowels are pronounced as in Italian and consonants as in English.

(b) Every letter is pronounced, and no redundant letters are introduced. When two vowels come together, each one is sounded, though the result, when spoken quickly, is sometimes scarcely to be distinguished from a single sound, as in *ai, au, ei*.

(c) One accent only is used, the acute, to denote the syllable on which stress is laid. This is very important, as the sounds of many names are entirely altered by the misplacement of this "stress."

6. Indian names are accepted as spelt in Hunter's "Gazetteer of India," 1881.

The following amplification of these rules explains their application:—

Letters.	Pronunciation and remarks.	Examples.
a	<i>ah</i> , <i>a</i> as in <i>father</i> ... ..	Java, Bandina, So-máli, Bari.
e	<i>eh</i> , <i>a</i> as in <i>fate</i> ... ..	Tel-el-Kebir, Oléfeh, Yezo, Medina, Le-víka, Peru.
i	English <i>e</i> ; <i>i</i> as in <i>ravine</i> ; the sound of <i>ee</i> in <i>beet</i> ... .. Thus, not <i>Feejee</i> , but <i>o</i> as in <i>mote</i> ... ..	Fiji, Hindi. Tokyo.
o	long <i>o</i> as in <i>flute</i> ; the sound of <i>oo</i> in <i>boot</i> , <i>oo</i> or <i>ou</i> should never be employed for this sound ... .. Thus, not <i>Zooloo</i> , but	Zulu, Sumatra.
u	<i>u</i> as in <i>law</i> .	Yarra, Tanna, Mecca, Jidda, Bonny. <sup>1</sup>
g	<i>All vowels are shortened in sound by doubling the following consonant</i> ... ..	
ai	Doubling of a vowel is only necessary where there is a distinct repetition of the single sound ... ..	Nuúlia, Oosíma.
ao	English <i>i</i> as in <i>ice</i> ... ..	Shanghai.
au	English <i>o</i> as in <i>now</i> ... .. Thus, not <i>Foochow</i> , but is slightly different from above ... ..	Fuchan.
aw	as in <i>law</i> .	Macao.
ei	is the sound of the two Italian vowels, but is frequently slurred over, when it is scarcely to be distinguished from <i>ey</i> in the English <i>they</i> ... ..	Beirút, Beilíf.
b	English <i>b</i> .	
c	is always soft, but is so nearly the sound of <i>s</i> that it should be seldom used ... ..	Celebes.
ch	If <i>Celbes</i> were not already recognized it would be written <i>Selbes</i> .	
d	is always soft as in <i>church</i> ... ..	Chingchin.
f	English <i>f</i> , <i>ph</i> should not be used for the sound of ... .. Thus, not <i>Hai-phong</i> , but is always hard. ( <i>Soft g</i> is given by <i>g</i> ) ... ..	Hai-fong, Nafa.
g	is always pronounced when inserted.	Gal-pagos.
h	as in <i>what</i> ; better rendered by <i>hw</i> than <i>wh</i> , or <i>h</i> followed by a vowel, thus, <i>Huang ho</i> , not <i>Whang ho</i> , or <i>Hoang ho</i> ... ..	Hwang ho, Ngan hw.
hw		
j	English <i>j</i> . <i>Dj</i> should never be put for this sound ... ..	Japan, Jinchuen.
k	English <i>k</i> . It should always be put for the hard <i>c</i> ... .. Thus, not <i>Corea</i> , but	Korea.
kh	The Oriental guttural ... ..	Khan.
gh	is another guttural, as in the Turkish ... ..	Dagh, Ghazi.
l		
m	As in English.	
n		
ng	has two separate sounds, the one hard as in the English word <i>finger</i> , the other as in <i>singer</i> . As these two sounds are rarely employed in the same locality, no attempt is made to distinguish between them.	
p	As in English.	
ph	stands both for its sound in <i>thing</i> , and as in <i>this</i> . The former is most common.	Chemulpho, Mokpho.
q	should never be employed; <i>qu</i> (in <i>quite</i> ) is given as <i>kw</i> ... ..	Bethlehem.
r	When <i>qu</i> has the sound of <i>k</i> as in <i>quoit</i> , it should be given by <i>k</i> .	Kwangtung.
s		
sh	As in English.	
t		
v		
w		Sawákin.
x		
y	is always a consonant, as in <i>yari</i> , and therefore should never be used as a terminal, <i>f</i> or <i>e</i> being substituted as the sound may require. Thus, not <i>Mikindány</i> , but	Kikóyu.
z	English <i>z</i> ... ..	Mikindáni.
zh	As in <i>tophate</i> ... ..	Kwale.
	The French <i>j</i> , or as <i>s</i> in <i>passure</i> ... ..	Zulu.
	Accents should not generally be used, but where there is a very decided emphatic syllable or stress, which affects the sound of the word, it should be marked by an acute accent ... ..	Muzhdaha.
		Tongatibu, Galá-pagos, Páikwan, Saráwak.

<sup>1</sup> The *y* is retained as a terminal in this word under Rule 2 above. The word is given as a familiar example of the alteration in sound caused by the second consonant.

THE ECLIPSE OF JANUARY 1, 1889.<sup>1</sup>

DURING the year 1889 two total eclipses occurred, one on January 1, and the other on December 21. The present report refers to the former, and contains a detailed account of all the work that was undertaken by those who formed

hamlet called Norman, on the north branch of the Southern Pacific Railway, about 130 miles from San Francisco. Situated south was Mount Shasta, and so nearly was it in the meridian that, as Prof. Pritchett says, "its snow-capped cone was used for instrumental adjustment without appreciable error."

The equipment as regards instruments included an equatorial

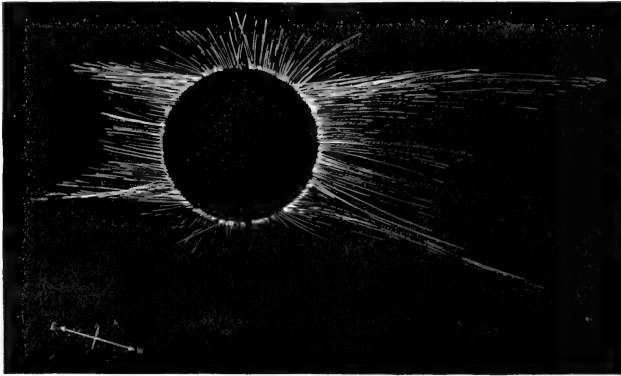

FIG. 1.—Prof. Engler's sketch of corona, 1889.

the party from the Washington University Observatory. Owing to the proximity of this Observatory to the path of totality, the chance of observing the eclipse was made the most of, but was only made possible, as Prof. Pritchett says, "by the kindness of Government officials and others in lending instruments, and by the liberality of friends of the University in subscribing money for the necessary expenses."

camera, with one of Dallmeyer's patent portrait and group lenses, size No. 8.D., having a clear aperture of 6.0 inches, and an equivalent focal length of 37.9 inches. Owing to the difficulty of keeping the tube light-tight, to prevent the fogging of the plates, an automatic shutter had to be used, the largest obtainable cutting the aperture down to 4.5 inches. Two telescopes were also employed—one being a 4-inch Clark's refractor

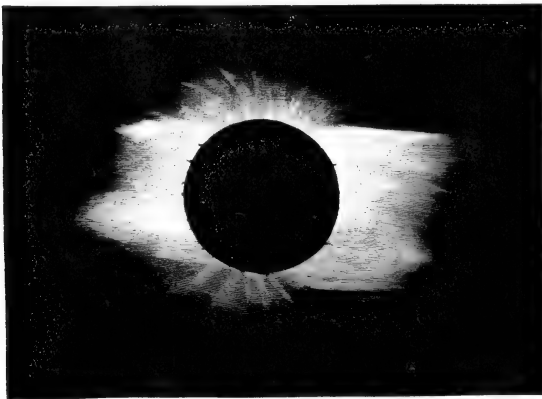

FIG. 2.—Composite photograph of corona, 1889.

The party consisted of Profs. H. S. Pritchett, Director of the Observatory, F. E. Nipher, and E. A. Engler, together with Prof. C. M. Charroppin, of the St. Louis University Observatory, and Prof. Señor Valle, of the National Observatory of Mexico.

The spot fixed upon for observing the eclipse was a small

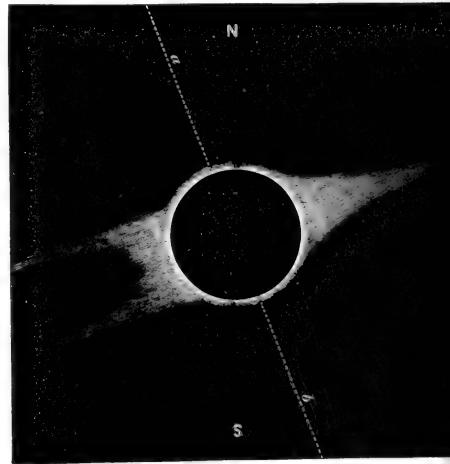

FIG. 3.—Lockyer's sketch of corona, 1875.

equatorially mounted, with magnifying powers from 50 to 400; the other a French instrument with an aperture of 3 inches, and an altitude and azimuth mounting.

Although the first contact was lost through the formation of a heavy bank of clouds, the sky near the sun soon afterwards became clear, and "the seeing was excellent and the image of the sun was sharp and distinct." In all the six negatives

<sup>1</sup> Report of the Washington University Eclipse Party.

obtained the definition was found to be very good, but on account of the difference in the lengths of the exposures given to the several plates, some of them proved to be rather thin. The task of developing them was imposed upon Prof. Charroppin, who gives a brief, interesting account of the process of their development. The observations of the times of contact and the study of the corona were undertaken by Prof. Engler, with the aid of the French instrument. Although only two contacts were recorded (the second and the fourth), he made no attempt at the third, owing to the short space of time at his disposal for observing and sketching the corona. The drawing which he made is produced (together with the other photographs) in this report, and tallies, when compared with them, in nearly all respects, with the exception of the two equatorial streamers on the west side, that appear to extend further westward than those recorded in the photographs.

It is interesting to note in the illustrations the great similarity between the corona observed in this eclipse and that of the year 1878, in which year the sun-spot disturbances were at the minimum. Figs. 1 and 2 represent the corona of the year 1889, the former being a drawing by Prof. Engler, the same as the one previously mentioned, while the latter is the integrated result of the examination of all the photographic plates, and "does not represent the corona as seen by the eye, nor as shown on any one of the negatives, but is a combination of all that could be found in the negatives."

The next illustration (Fig. 3) is a sketch of the corona made by Mr. Lockyer during the eclipse of 1878 (*NATURE*, vol. xviii. p. 457), and when compared with the above figures fully bears out the idea that at the several periods throughout a sun-spot cycle there corresponds in the corona a like period, which is apparent to us only in the changes of form undergone by the equatorial and polar streamers, and this only at the time of eclipses.

The following brief extracts, which we give in the observers' own words, will show how the descriptions of the appearance of the corona resembled one another in all the main points. With regard to the structure at the north and south poles, Mr. Lockyer says (*NATURE*, vol. xviii. p. 457):—

"I had a magnificent view of the corona with a power of 50 on my 3½-inch Cooke, and saw exquisite structure at the north and south points. Curves of contrary flexure started thence, and turned over, and blended with the rest of the corona, which was entirely structureless and cloudlike; the filamentous tracery, which in India I observed till three minutes after totality, had indeed almost gone. Prof. Bass, however, tells me that by confining his attention to the same point for nearly the whole time of totality, the structure came out and seemed to pulsate like an aurora."

Prof. Pritchett's account is almost the same, word for word, as may be seen from the following extract:—

"I was particularly struck," he says, "with the brilliant appearance in the telescope of the filaments at the north and south limbs of the sun. They seemed radial at the poles, but gradually bending over and merging into the equatorial streamers in passing from the pole to the equator. I could not resist the impression that these filaments pulsed."

From the above it will be seen that the appearances at the pole for both years were very similar; and with regard to the equatorial streamers also, their notes show that the characteristic features of each coincided in almost all particulars. Owing to the fact of the minimum spot period occurring at both eclipses, the above results strengthen very considerably the hypothesis connecting the spot cycle with the corona.

In addition to Prof. Engler's drawing mentioned above, Señor Valle also made some eye observations of the coronal streamers. The method he adopted was similar to that employed by Prof. Newton in 1878, and consisted in placing a screen in such a position that during totality the moon and the brighter corona were cut off. The photo-engraving of the drawing shows an extension of the equatorial streamers to about a distance of three solar diameters, while the polar regions were described as of a curved luminous filamentary contraction.

Before concluding, we must not forget to mention the admirable artotype reproductions, at the end of the report, of all the negatives: as they are arranged in the order of the times of exposure, they show well the progressive increase of detail on the outer part of the corona as the exposure was lengthened.

W.

SIMPLE PROOF OF EUCLID II. 9 AND 10.

THE following proof of Euclid II., 9 and 10, believed to be new, due to Miss Hilda Hudson, was communicated to the London Mathematical Society at their last meeting.

AB is bisected in C and divided unequally in D either internally (II. 9) or externally (II. 10). It is required to prove that the sum of the squares on AD and DB is equal to twice the sum of the squares on AC and CD.

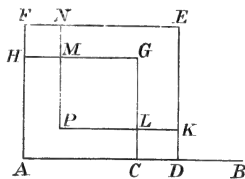

II. 9.

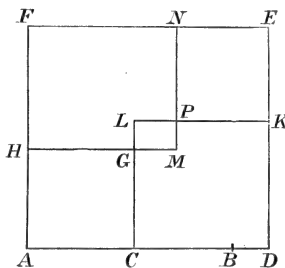

II. 10.

On AD, AC, CD, describe the squares ADEF, ACGH, CDKL, all on the same side of AB.

On FH, within the square AE, describe the square FHMN; this is equal to the square on CD.

Let NM, KL, produced if necessary, meet in P.

Then PE is a square equal to the square on AC.

And APG is a square equal to the square on DB.

The sum of the squares on AD, DB is equal to the figures AE and PG, that is to AG, PE, FM, and CK, that is to twice the sum of AG, CK, that is to twice the sum of the squares on AC, CD.

SCIENTIFIC SERIALS.

*American Meteorological Journal* for November.—Prof. H. A. Hazen gives the results of three rather high balloon voyages in the United States, in which he took part. (1) June 25, 1886, at 7h. 50m. a.m., a dense cloud was entered at 1000 feet, which seemed like a dry fog. The temperature from the earth up to more than half-way through the cloud hardly varied a degree, but after that it rose rapidly. There was a region of marked dampness at 7000 feet. The temperature at starting was 61°·3, and at 9640 feet it had fallen to 8°; time, 9h. 16m. (2) June 11, 1887, at 2h. 34m. p.m., temperature 90°·6. At 15,080 feet, it had fallen to 40°; time, 6h. 18m. p.m. Great dryness was experienced in the upper strata. There were two rather sharply defined layers of dampness, at 7500 feet and at 12,000 feet. (3) August 13, 1887, at 3h. 35m. p.m., temperature 75°·8. At 6940 feet it was 53°·3; time, 6h. 28m. p.m. The relative humidity fell to 8 per cent.—Meteorology at the French Association at Marseilles, by A. L. Rotch. Among the most interesting papers was one by M. Crova, upon the analysis of diffused light. Observations made at Montpellier at the zenith show the blue to be greatest in the early morning, and least about 2 p.m., and then increasing until towards evening. A cloudy sky also shows

a considerable amount of blue rays. M. Teisserenc de Bort explained the existence of a vertical barometric gradient, first noticed in mountain observations, but lately measured more exactly on the Eiffel Tower.—The zodiacal light as related to terrestrial temperature observations, by O. T. Sherman.—Features of Hawaiian climate, by C. L. Lyons, in charge of the Weather Service there. The temperature averages for January are 69° to 71°, and in July and August 78° and 79°. The daily range is greater than is generally supposed, averaging 11° for the year, and some days over 20°. The maximum temperature is 89°, and the minimum 55°.—High-level meteorological observatories in France, by A. L. Rotch; and other articles of minor importance.

### SOCIETIES AND ACADEMIES.

LONDON.

Royal Society, December 17.—“The ‘Ginger-beer Plant, and the Organisms composing it: a Contribution to the Study of Fermentation-yeasts and Bacteria.” By H. Marshall Ward, Sc.D., F.R.S., F.L.S., Professor of Botany at the Forest School, Royal Indian Engineering College, Cooper’s Hill.

The author has been engaged for some time in the investigation of a remarkable compound organism known to villagers as the “ginger-beer plant.”

It occurs as jelly-like, semi-transparent, yellowish-white masses, aggregated into brain-like clumps, or forming deposits at the bottom of the fermentations, and presents resemblances to the so-called *Kephir* grains of the Caucasus, with which, however, it is by no means identical.

He finds that it consists essentially of a symbiotic association of a specific *Saccharomycete* and a *Schizomycete*, but, as met with naturally, invariably has other species of yeasts, bacteria, and mould-fungi casually associated with these.

He has successfully undertaken the separation of the various forms, and groups them as follows:—

(1) The essential organisms are a yeast, which turns out to be a new species allied to *Saccharomyces ellipsoideus* (Reess and Hansen), and which he proposes to call *S. pyriformis*; and a bacterium, also new and of a new type, and named by him *Bacterium vermiforme*.

(2) Two other forms were met with in all the specimens (from various parts of the country and from America) examined—*Mycoderma cerevisiæ* (Desm.) and *Bacterium aceti* (Kützing and Zopf).

(3) As foreign intruders, more or less commonly occurring in the various specimens examined, were the following:—

a. A pink or rosy yeast-like form—*Cryptococcus glutinis* (Fresenius)?

β. A small white aerobic top-yeast, with peculiar characters, and not identified with any known form.

γ. The ordinary beer-yeast—*Saccharomyces cerevisiæ* (Meyen and Hansen).

δ. Three, or probably four, unknown yeasts of rare occurrence.

ε. A bacillus which forms spores, and liquefies gelatine with a greenish tinge.

ζ. A large spore-forming bacillus, which also liquefies gelatine.

η and θ. Two—perhaps three—other *Schizomycetes* not identified.

ι. A large yeast-like form which grows into a mycelium, and turns out to be *Oidium lactis* (Fresenius).

κ. A common blue mould—*Penicillium glaucum* (Link).

λ. A brown “Torula”-like form, which turns out to be *Dematium pululianus* (De Bary).

μ. One, or perhaps several, species of “Torula” of unknown origin and fates.

*Saccharomyces pyriformis* (n. sp.) is a remarkably anaerobic bottom-yeast, forming spores, and developing large quantities of carbon dioxide, but forming little alcohol. It has also an aerobic form—veil form of Hansen—in which the rounded cells grow out into club-shaped or pyriform cells, whence the proposed specific name. It inverts cane sugar, and ferments the products; but it is unable to ferment milk sugar. It forms rounded, morula-like, white colonies in gelatine, and the author has separated pure cultures from these. He has also studied the development and germination of the spores, which are formed in 24 to 48 hours at suitable temperatures on porous earthenware blocks. They also develop on gelatine.

The specific *Schizomycete* (*Bacterium vermiforme*, n. sp.) has been very fully studied by the author. It occurs in the fermentations as rodlets or filaments, curved or straight, encased in a remarkably thick, firm, gelatinous sheath, and is pronouncedly anaerobic, so much so, that the best results are got by cultivating it in carbon dioxide under pressure.

The sheathed filaments are so like worms, that the name proposed for the species is appropriately derived from this character.

It will not grow on gelatine, and separation cultures had to be made in saccharine liquids by the dilution methods.

It grows best in solutions of beet-root, or of cane sugar, with relatively large quantities of nitrogenous organic matter—e.g. bouillon, asparagin—and tartaric acid. Good results were obtained with mixtures of Pasteur’s solution and bouillon.

The author found that the bacterium into which the filaments subsequently break up can escape from its sheath and become free, in which state it divides rapidly, like ordinary bacteria. Eventually, all the forms—filaments, long rods, short rodlets—break up into cocci. No spores have been observed. These changes are dependent especially on the nutritive medium, but are also affected by the gaseous environment and the temperature. The jelly-like clumps of the so-called “ginger-beer plant” are essentially composed of these sheathed and coiled *Schizomycetes*, entangling the cells of *Saccharomyces pyriformis*. But the fermentative actions of the *Schizomycete* on the saccharine medium are different when alone, from those exercised when associated with the yeast, or from those exerted by the latter alone.

This was proved by cultivating each separately, and also by cultivations in which, while each organism was submerged in the same fermentable medium, they were separated by permeable porcelain (Chamberland filters), through which neither could pass.

The author has also reconstructed the “ginger-beer plant” by mixing pure cultures of the above two organisms; the *Schizomycete* entangled the yeast-cells in its gelatinous coils, and the synthesized compound organism behaved as the specimens not analyzed into their constituents. The symbiotic compound organism so closely resembles a lichen, in its morphological aspects, that it may be said to be a ferment-lichen.

Some very curious phenomena in connection with the formation of the gelatinous sheaths and the escape of the bacteria from them were observed in hanging-drop-cultures, and are figured and described by the author. The conditions for the development of the gelatinous sheaths—and therefore of the coherent brain-like masses of the *Schizomycete*—are a saccharine acid medium and absence of oxygen. The process occurs best in carbon dioxide: it is suppressed in bouillon, and in neutral solutions in hydrogen, though the organism grows in the free, non-sheathed, motile form under these conditions.

The behaviour of pure cultures of the bacteria in as complete a vacuum as could be produced by a good mercury pump, worked daily, and even several times a day, for several weeks, is also noteworthy. The development of the sheaths is apparently indefinitely postponed *in vacuo*, but the organism increased, and each time the pump was set going an appreciable quantity of carbon dioxide was obtained. In vacuum tubes the same gas was evolved, and eventually attained a pressure sufficient to burst some of the tubes. The quantity of carbon dioxide evolved daily by the action of the bacterium alone, however, is small compared with that disengaged when the organism is working in concert with the symbiotic yeast; in the latter case the pressure of the gas became so dangerous that the author had to abandon the use of sealed tubes.

The products of the fermentation due to the *Schizomycete* have not yet been fully determined in detail; lactic acid, or some allied compound, seems to be the chief result, but there are probably other bodies as well. The author considers that the bacterium removes from the sphere of action substances which, if accumulated, would exhibit the fermentative power of the yeast, hence the advantages of the symbiosis.

The pink yeast-like form proved to be very interesting. It has nothing to do with the “ginger-beer plant” proper, though it was invariably met with as a foreign intruder in the specimens. The author identifies it with a form described by Hansen in 1879 (“Organismer i Öl og Olurt,” Copenhagen, 1879); unfortunately the original is in Danish, but the figures are so good that little doubt is entertained as to the identity. It is also probably the same as Fresenius’s *Cryptococcus glutinis* in one of its forms. It is not a *Saccharomycete*, and does not ferment like a yeast; it is aerobic.



The chief discovery of interest was that in hanging drops the author traced the evolution of this "rose-yeast" into a large complex mycelium, bearing conidia, and so like some of the Basidiomycetes that it may almost certainly be regarded as a degraded or "torula" stage of one of these higher fungi. Full descriptions and figures are given by the author.

The form *Mycoderma cerevisia* was thoroughly examined. The author's results confirm what is known as to its aerobic characters. Statements as to its identity with *Oidium lactis* were not only not confirmed, but the author grew these two forms side by side, and maintains their distinctness. Nor could he obtain spores in this fungus, thus failing to confirm earlier statements to the contrary. He regards it as probable that oil-drops have been mistaken for spores; he also finds that in later stages of fermentation by this organism a strong oily-smelling body is produced.

With regard to *Bacterium aceti*, the author has nothing new to add. A point of some interest was the repeated production of acetic ether, which scented the laboratory, when this Schizomycete was growing in company with the small white aerobic top-yeast referred to under (8). Full details regarding the rest of the organisms, which have nothing to do with the "ginger-beer plant" proper, are given in the original paper.

Physical Society, December 4.—Prof. W. E. Ayrton, F.R.S., President, in the chair.—A paper on a permanent magnetic field was read by Mr. W. Hibbert. The author had noticed the approximate constancy of an "aged" bar magnet, and he obtained still greater constancy by attaching pole pieces to a bar magnet, of such a shape as to give a nearly closed circuit of small "magnetic resistance." The pattern now described consists of a steel rod 1 inch diameter and about  $2\frac{1}{2}$  inches long, with a cast-iron disk 4 inches diameter and  $\frac{1}{2}$  inch thick fixed at one end; the other end is fitted in a hemispherical iron shell which surrounds the bar and comes flush with the upper surface of the disk. An annular air space less than  $\frac{1}{16}$  inch wide is left between the cylindrical surface of the disk and the inside of the shell, and when the bar is magnetized, a strong magnetic field exists in this space. To use this field for producing electromagnetic impulses, a coil of wire is wound in a shallow groove on a brass tube which can slide axially through the annular space, thus cutting all the lines. The tube is allowed to fall by its own weight, a neat trigger arrangement being provided for effecting its release. The instrument exhibited had 90 turns of wire in the coil, and the total magnetic flux across the air space was about 30,000 C.G.S. lines. A large electro-magnetic impulse is, therefore, obtainable even through resistances as great as 10,000 ohms. Tests of three instruments show that there has been practically no magnetic decay in seven months. The author, therefore considers them satisfactory, and is prepared to supply them as magnetic standards. To facilitate calculation, the number of lines will be adjusted to a convenient number, say 20,000 or 25,000. Several uses to which the instruments are well suited are mentioned in the paper, and a simple way of determining permeability by the magnetometer method is described. Mr. Blakesley thought the name given to the instrument was inappropriate, for it really gave a constant impulsive E.M.F. Dr. Sumpner said the constancy of the sensibility of Arsonval galvanometers was a measure of the constancy of magnets having nearly closed circuits. Such instruments, in use at the Central Institution, had remained unchanged for several years. Prof. S. P. Thompson admired Mr. Hibbert's instrument, and thought it would be very useful in laboratories. Standard cells, he said, were not always reliable, and condensers were the most unsatisfactory of electrical standards. On the subject of permanency of magnets, he said that Strouhal and Barus found that magnets with nearly closed circuits were most constant, and that, to give the best results, the hardness of the steel should be less the more closed the circuit. Mr. Hookham had also found that by using a nearly closed circuit, and reducing the strong magnetization by about 10 per cent., great constancy could be obtained. Some years ago he (Dr. Thompson) had tried the effect of ill-treatment on magnets, and observed that touching or hitting a magnet with non-magnetic material had little effect, whilst similar treatment with iron or magnets affected them considerably. Suddenly removing the keeper of a magnet tended to increase the magnetism, whilst putting a keeper on suddenly had the reverse effect. Strouhal and Barus had also investigated the temperature coefficient of magnets, and found that this might be reduced by

subjecting the magnet to rapid changes of temperature after the first magnetization, and then remagnetizing. Mr. W. Watson inquired what was the percentage fall in strength of Mr. Hibbert's magnets. The bars used in magnetic surveys had been tested frequently, and they lost about 0.5 per cent. in 6 months. The President asked what were the temperature coefficients of the magnets described in the paper? Mr. Evershed, he said, thought it was between 0.01 per cent. and 0.05 per cent. for ordinary magnets. He thought the instrument shown by Mr. Hibbert would be of immense value if the magnet was really permanent. By it ballistic galvanometers could be readily calibrated, and, when combined with a resistance box, it could also be used as a standard for current; for, since the constant of a ballistic galvanometer for quantity can be determined from its constant for current, if the periodic time be known, conversely that for current can be found from the constant for quantity. In some instances this would be of great use. Speaking of the temperature coefficient of condensers, he said that in some cases the specific inductive capacity of dielectrics diminished with rise of temperature whilst in others it increased. Mr. Hibbert, in reply, said he found the temperature coefficient of his magnets to be, roughly, about 0.03 per cent., but he had not investigated the matter very carefully. In making his measurements no correction had been made for the variation of capacity of his condenser with temperature.—Mr. Walter Baily took the chair, and the President communicated a note on rotatory currents. The subject, he said, was probably familiar to most persons present, for it had been frequently referred to in the scientific papers. Alternate currents could be obtained from an ordinary direct current dynamo by making contact with two points in the armature, say by connecting these points to insulated rings on the shaft, and using extra brushes. A direct current motor similarly treated transforms direct currents into alternating currents, or into mechanical power. If two pairs of points in the armature be selected, situated at opposite ends of two perpendicular diameters, then two alternating currents differing in phase by 90° can be obtained; and by choosing suitable points in the armature, two, three, or more currents differing in phase by any desired angles can be produced. In ordinary motors the connections for doing this would be troublesome, but the Ayrton and Perry form, which has a stationary armature, lends itself readily to this purpose, for contact can be made with any part of the armature with great facility. A motor of this kind was exhibited, in which contact was made with four equidistant points on the armature. On connecting opposite points through fine platinum wires, and running the motor slowly, the wires glowed alternately, one being bright whilst the other was dark, and *vice versa*, thus demonstrating the existence of two currents in quadrature. When the four points on the armature were joined to the four corners of a square of platinum wire, the wires became incandescent in succession, the glow appearing to travel round the square, and suggesting the idea of rotatory currents. A Tesla alternating current motor was also driven by two currents differing in phase by 90°, obtained from the armature of the Ayrton and Perry direct current motor above mentioned. The ease with which currents differing in phase by any amount can be obtained from such a motor led the author to investigate theoretically the case of two circuits connecting opposite ends of two diameters inclined at any angle,  $\alpha$ . Calling the currents in these circuits at any instant,  $A_1$  and  $A_2$ , he had found that

$$A_1 = 2nE_0 \frac{\sqrt{\left(r_2 + \rho \frac{\pi}{2}\right)^2 + \rho^2 \left(\frac{\pi}{2} - \alpha\right)^2} - 2\left(r_2 + \rho \frac{\pi}{2}\right) \rho \left(\frac{\pi}{2} - \alpha\right) \cos \alpha}{\left(r_1 + \rho \frac{\pi}{2}\right) \left(r_2 + \rho \frac{\pi}{2}\right) - \rho^2 \left(\frac{\pi}{2} - \alpha\right)^2}$$

multiplied by  $\sin(\beta + \phi)$ ;

where  $n$  = number of turns on armature per radian,  
 $\rho$  = resistance of armature per radian,  
 $r_1$  = resistance of external circuit in which current  $A_1$  passes,  
 $r_2$  = resistance of external circuit in which current  $A_2$  passes,  
 $E_0$  = maximum E.M.F. per convolution  
 $\alpha$  = angular velocity of rotation, and

$$\tan \phi = \frac{\rho \left(\frac{\pi}{2} - \alpha\right) \sin \alpha}{r_2 + \rho \frac{\pi}{2} - \rho \left(\frac{\pi}{2} - \alpha\right) \cos \alpha}$$

A similar expression, in which  $r_1$  is written for  $r_2$ , and  $r_2$  for  $r_1$ , gives the value of  $A_2$ . The phase angle between the currents is given by

$$\tan(\phi + \psi) = \frac{\left(r_1 + \rho \frac{\pi}{2}\right) \left(r_2 + \rho \frac{\pi}{2}\right) - \rho^2 \left(\frac{\pi}{2} - \alpha\right)^2}{\left(r_1 + \rho \frac{\pi}{2}\right) \left(r_2 + \rho \frac{\pi}{2}\right) + \rho^2 \left(\frac{\pi}{2} - \alpha\right)^2 - \rho \frac{\pi}{2} \left(\frac{\pi}{2} - \alpha\right) \left(r_1 + \rho \frac{\pi}{2}\right)} \tan \alpha$$

The expression for  $\phi$  shows that the phase of the current in circuit  $A_1$  is independent of the resistance  $r_1$ . On the other hand, varying  $r_2$  alters  $\phi$ . It was also pointed out that  $\tan(\phi + \psi)$  is generally greater than  $\tan \alpha$ .—Prof. J. Perry, F.R.S., read a paper on struts and tie-rods laterally loaded. He pointed out that, in the case of struts, a slight want of straightness may considerably reduce the breaking load. Even if a strut be originally straight and the thrust properly distributed, its weight usually produces lateral loading and consequent bending. Similarly, centrifugal force produces lateral loading in connecting rods. For some years the author has given his students practical examples of struts and tie-rods to work out, taking into account the effect of lateral loads. The chief results obtained, together with a general treatment of the whole subject, are embodied in the paper. Where the curves of bending moment and the deflections due to lateral loading can be easily developed by Fourier's series, solutions can readily be found. Simple cases of uniformly loaded struts and tie-bars have been fully worked out, and also the case of locomotive coupling rods. In one problem on the latter subject, a rectangular cross-section was chosen, and the proportions of depth to breadth determined so as to make the rod equally strong in the two directions when running at various given speeds. With cranks 12 inches long, the results show that, at a speed of 390 revolutions per minute, the ratio of depth to breadth must be infinite, so as to give equal strength, so great is the influence of the lateral loading due to centrifugal force, when combined with the thrust. Horizontal tie-rods loaded by their own weight have been investigated, and the tensions required to neutralize compression due to bending determined. A steel bar, 1 inch diameter and 48 inches long, was used as a strut, with a thrust of 1500 pounds. The maximum stress, due to bending by its own weight alone, was 810, and on applying the thrust the maximum stress was raised to 23,190, or about 26 times that due to lateral loading alone. More complex cases have also been treated, the results of which are given in the paper.

PARIS.

Academy of Sciences, December 14.—M. Duchartre in the chair.—On the distribution of prime numbers, by M. H. Poincaré.—On the fixation of nitrogen by arable soils, by MM. Arm. Gautier and R. Drouin. The conclusion is drawn that only soils containing organic matter fix the free or ammoniacal nitrogen of the atmosphere, even in the absence of plants, and that the organic matter existing in all arable soil is an indispensable intermediary in this fixation of nitrogen.—On the camphoric and isocamphoric esters, and the constitution of the camphoric acids, by M. C. Friedel.—Remarks on the history of supersaturation, by M. Lecoq de Boisbaudran. The author gives some notes, made by him in 1866, on the subject of supersaturation, which are in agreement with the phenomena of solution observed in recent years.—Observations of Borrelly's asteroid (Marseilles, November 27, 1891), made at Paris with the East Tower equatorial, by Mdlle. Klumpke. Observations for position were made on November 30, December 2 and 5.—On integrals of the second degree in problems of mechanics, by M. R. Liouville.—On a class of congruences of lines, by M. A. Petot.—On the actual state of geodetic and topographic works in Russia, by General Venukoff.—A brief note on the maps of Russia, prepared under the direction of General Kowersky.—On circular polarization, by M. E. Carvallo.—On a thermo-electric standard of electromotive force, by M. Henri Bagard. The author has experimented with thermo-electrolytic couples consisting of two liquids, one an amalgam of zinc, containing a known proportion of this metal, and the other a solution of sulphate of zinc. He finds that such a couple is absolutely constant between two given temperatures, its electromotive force between 0° and 1° being given by the formula—

$$E_{\theta}^{\theta} = 0.001077t + 0.00000090t^2.$$

And it is not necessary to exercise any great precision in the determination of the weight of zinc dissolved in the known weight of mercury to form the amalgam, for the variation of the electromotive force when the couple is at the temperatures 0° and 100° appears to be only 0.0001 volt when the proportion of zinc was varied from 0.00025 to 0.00075 the mass of the mercury.—The three basicities of phosphoric acid, by M. Daniel Berthelot. The basicities have been investigated by the author using a method of determining the electric conductibilities of phosphoric acid solution, and of the same with varying quantities of soda, potash, or ammonia respectively added. The conclusion is drawn that monobasic and dibasic phosphates are stable even in dilute solution, and that the tribasic alkaline phosphates are nearly completely dissociated in dilute solution. Phosphoric acid differs completely from the true tribasic acids as the monobasic and dibasic salts of the latter are partially dissociated by water, and the tribasic salts, on the contrary, are stable in solution.—Salts in solution, sodium sulphate and strontium chloride, by M. A. Etard.—A green solid chromic sulphate, by M. A. Recoura. It has the formula  $Cr_2(SO_4)_3 \cdot 11H_2O$ .—Bismuthic acid, by M. G. André.—On the distillation of oil, by M. Pierre Mahler.—A new porcelain, asbestos porcelain, by M. F. Garros.—On the presence of reticulated tissue in the muscular walls of the intestines, by M. de Bruyne.—On the first phases in the development of *Crustacea edriophthalma*, by M. Louis Roule.—On *Gymnorhynchus reptans*, Rud., and its migration, by M. R. Moniez.—On the rôle of the foot as a prehensile organ in Hindoos, by M. Felix Regnault. Many travellers have remarked on the ability possessed by most Hindoos of using the foot as well as the hand in work of all descriptions. M. Regnault has made some measurements of the lengths of the feet and toes of a number of natives, and draws some conclusions therefrom as to the adaptation "of the organ to the function."—On the discovery of Tertiary shells in the volcanic tufa of Limburg (Grand Duchy of Baden), by M. Bleicher.—The circulation of winds on the surface of the earth; fundamental principles of the new theory, by M. Duponchel.

CONTENTS.

PAGE

Botanical Nomenclature. By W. Botting Hemsley, F.R.S.	169
Applied Thermodynamics. By Prof. A. G. Greenhill, F.R.S.	172
British Flies	173
Our Book Shelf:—	
Wright: "Principles of Agriculture"	173
Dyer and Whitcombe: "Elementary Trigonometry"	174
Letters to the Editor:—	
Opportunity for a Naturalist.—Dr. P. L. Sclater, F.R.S.	174
Warning Colours. (Illustrated.)—Edward B. Poulton, F.R.S.; W. L. Distant	174
A Difficulty in Weismannism.—A. H. Trow	175
Destruction of Immature Sea-Fish.—Alfred O. Walker	176
The Salts in Natural Waters.—F. H. Perry Coste; Robert B. Hayward, F.R.S.	176
Peculiar Eyes.—E. B. Titchener	177
Alleged Pseudopodes of Diatoms.—Alfred W. Bennett	177
Intelligence in Birds.—Joe	177
A New Locality for Meteoric Iron, with a Preliminary Notice of the Discovery of Diamonds in the Iron. (Illustrated.) By Prof. A. E. Foote	178
The Sever's Gale of November 11. (With Charts.) By Chas. Harding	181
Notes	182
Our Astronomical Column:—	
Capture of Comets by Planets	186
Law of Limiting Apertures	186
Connaissance des Temps	186
Orthography of Geographical Names	186
The Eclipse of January 1. (Illustrated.) By W.	188
Simple Proof of Euclid II. 9 and 10. (With Diagrams.) By Miss Hilda Hudson	189
Scientific Serials	189
Societies and Academies	190

THURSDAY, DECEMBER 31, 1891.

## THE PHYSICAL THEORY OF SOLUTION.

*Solutions.* By W. Ostwald. Translated by M. M. Pattison Muir. Pp. 316. (London: Longmans, Green, and Co., 1891).

WITH certain additions this work is a translation of Book IV. of the second edition of Ostwald's "Lehrbuch der allgemeinen Chemie." At the present time there is no department of physical chemistry which is receiving more attention, and which is the subject of more controversy, than that of solutions. On the Continent, the physical theory of solution, arising out of the ideas of van 't Hoff and Arrhenius, has obtained, for the most part, ready acceptance. Although the earlier of these conceptions is but some six years old, their applications and the facts accumulated around them have already become so numerous that to piece fact and theory together, and keep the main issues of the case to the fore, is a necessity. To carry out these ends no one is better fitted than the Professor of Chemistry in the University of Leipzig. Prof. Ostwald is one of the warmest supporters of the physical theory, and has done more, perhaps, than any other, to make it what it now is.

As contrasted with its reception on the Continent, the new theory has had but little favour shown to it in this country. Men of science on this side of the Channel have, as a rule, been unwilling to grant the more startling consequences which follow in its wake, and have offered more or less decided opposition to its progress. Of late, too, the claims of a special development of the rival hydrate or chemical theory have been brought prominently under their notice. There is therefore a certain fitness in the publication of a "full and authoritative statement" in English of the merits of the physical theory.

The book opens with a definition of solutions. In the light of the physical theory these are "homogeneous mixtures which cannot be separated into their constituent parts by mechanical means." Granting this definition, it forms a basis for classifying the different kinds of solutions, and these, together with the conditions under which they are formed, and under which they exist, are discussed in the first four chapters.

Chapter i., solutions in gases, begins with an account of Dalton's law of partial pressures, and the deviations from the law brought to light by the work of Regnault, Andrews, and others. The somewhat novel result that this gaseous law should be found under the heading solutions, follows, of course, from the fact that a gaseous mixture satisfies the definition quoted. The rest of the chapter is taken up with the evaporation of liquids and solids, as these processes may be regarded as instances of the solution of liquids and of solids in gases.

Solutions in liquids are considered in the next three chapters. Chapter ii. is devoted to solutions of gases in liquids. Henry's law, its verification by Bunsen, the methods of determining absorption coefficients, and the exceptions to Henry's law shown by aqueous solutions of ammonia, hydrogen chloride, &c., are given first. Then follow sections on the theory of gas-absorption, on absorption by saline solutions and by mixed liquids, and on

the volume changes of liquids accompanying absorption. Chapter iii. deals with mixed liquids, classified according as they are miscible in all proportions, partially miscible, or practically immiscible. Alexejeff's interesting curves representing the mutual solubility of different pairs of liquids at different temperatures here find a place. The observations of Konowloff on the vapour pressures of mixed liquids are described at some length, and are worthy of attention, in particular those relating to liquids miscible in all proportions, as they are of especial value in the process of fractional distillation.

Chapter viii. of Book V. of the "Lehrbuch," solutions of solids in liquids, is now introduced. That it is not quite continuous with its predecessors is apparent by the abrupt mention of osmotic pressure, and the use of van 't Hoff's factor  $z$ , reference being made by the translator to succeeding chapters for explanations. Free application of the gaseous laws to solutions is made in this chapter, which treats of supersaturation, the influence of external pressure and of temperature on solubility, the volume relations of solutions, the influence of melting on solubility, the solubilities of mixtures, the effect of acids on the solubilities of their salts, solutions in mixed liquids, &c. The emphasis laid on the fact that in a saturated solution in contact with undissolved substance, the latter plays an important part in the conditions of equilibrium, is noteworthy.

Under osmose, is next given an account of osmotic pressure, and of the work of Traube, Pfeffer, de Vries, and others, with the theoretical deductions of van 't Hoff which were founded on such researches, and which resulted in quantitative support to the idea of the analogy between solutions and gases. This chapter might with profit have been given at an earlier stage, at least before the previous one, on the solution of solids in liquids.

The chapter following, on the diffusion of dissolved substances, contains a valuable abstract of the main investigations on this subject, from the time of Graham down to the present, when Fick's fundamental law of diffusion follows, as shown by Nernst, from consideration of the effect of osmotic pressure.

Chapters vii. and viii. treat respectively of the vapour pressures and freezing-points of solutions. A full and historical account, with the practical applications to molecular weight estimations, is given in each case. Salt solutions are next discussed, the leading idea of the chapter being to prove that the properties of electrolytes are additive, or can be expressed as the sum of the properties of their constituent ions. Both chemical and physical properties are quoted in support of the existence of free ions in salt solutions. The last chapter is devoted to the simultaneous action of different solvents. The use of some of the results as new methods of determining molecular weights is also indicated.

On the whole, the book is a very suggestive one. The historical method adopted in each chapter adds much to the interest. The arrangement of the facts concerning solutions, and the copious references to original memoirs, are alone sufficient to make the book valuable; and to many, those chapters, such as that on diffusion, which deal mainly with fact, will be the most useful. Even although, in the investigation of solution, the use of the gaseous laws be nothing more than the carrying out of a mere

analogy, nevertheless theoretical speculations and practical researches are indicated, which, in the long run, must throw more light on the question.

But, in spite of all this, the book is not satisfying. The main objections which have been urged against the physical theory still exist.

To the fundamental question—"Is solution a physical or a chemical process?"—the answers are various. The opening definition and much that follows seem quite decisive on this point: "Solutions are homogeneous mixtures."

Dissolved substances obey gaseous laws because

"the molecules of the solvent in the interior of the solution act equally in all directions on each molecule of the dissolved substance, these molecules are all free to move as if there were, on the whole, no action upon them. Hence it follows that the kinetic energy of the molecules of the dissolved substance is equal to that of the gas at the same temperature."

The deviations of concentrated solutions from the simple gaseous laws are explained by the fact that in such cases the osmotic pressure is high, and that "compound gases of simple composition show marked deviations from the gaseous laws at such pressures."

The inference from such statements obviously is, that solution is purely physical; to the dissolved substance are to be ascribed even the deviations from the gaseous laws; the solvent may be ignored. This is, indeed, the logical outcome of the physical theory.

On the other hand, evidence such as the following has to be considered:—

"Every liquid is capable of taking up every gas, and combining therewith to form a homogeneous liquid or solution. . . . Two classes of these gas-solutions are to be distinguished. . . . In cases belonging to the second class, e.g. in a solution of hydrogen chloride in water, we have sufficient grounds to assert that *chemical change* occurs."

The distinction drawn between crystalloids and colloids is of the same order as the above:—

"Those of the first group (crystalloids) dissolve in water with more or less marked changes of temperature; they raise the boiling-points, lower the freezing-points, and generally exert a marked influence on the properties, of their solutions. The others (colloids) do not exhibit all these properties: their solutions are *mechanical mixtures* rather than *compounds*."

Experiment has shown that the molecular weight of the same dissolved substance, obtained by the Raoult methods, varies in many cases with the solvent. In order to make theory harmonize with practice, this explanation is given:—

"We know that iodine, sulphur, and many other substances exist in different molecular conditions. It is not, then, to be wondered at that a definite substance should exhibit different molecular conditions when dissolved in different solvents. The different solvents act like *different temperatures or pressures*."

The notion of a passive solvent evidently does not here apply. Even on making allowance for a loose use of the terms mixture and compound, it is hard to see how these latter statements accord with the ideas of the functions of the solvent and dissolved substance derived from those quoted previously.

That the book is a portion of a larger treatise is evident, to its detriment, in several ways. One instance, which can hardly escape observation, is the absence of any detailed account of the support to the physical theory which has been drawn from the electrolysis of solutions. At first sight, it is difficult to conceive that, in a work on the physical theory, of which the hypothesis of electrolytic dissociation is an integral part, no mention should be made of the quantitative estimate of the degree of dissociation which has been derived from a study of electric conductivity. The reason is, that electro-chemistry is treated in Vol. II. of the "Lehrbuch," and a second edition of this volume is not yet published. It would have been judicious to have delayed publication of this book till portions of the subject of electro-chemistry could have been included.

It would have been desirable, it seems to us, to have made some adequate reference to other theories which have been put forward in explanation of the phenomena of solution. The only statement which can be construed into an allusion to the hydrate theory occurs when treating of the point as to whether or not a salt in aqueous solution is united with its water of crystallization. And here the question is somewhat contemptuously disposed of:—

"The endeavours of many investigators to find proofs in favour of the existence in solutions of combined water of crystallization have not led to results which can be received without objection; these endeavours may therefore be passed over."

Fault might well be found on the score of incompleteness with much of the evidence put forward in portions of the book. The chapter on salt solutions is one of the most striking; it is, indeed, the only one which has for its theme the dissociation hypothesis; and bearing in mind the contention which this hypothesis has created, here if anywhere the matter put forward should have been beyond criticism. Tables are given of compressibilities, surface-tensions, viscosities, &c.; while, to begin with, these properties are not defined, and several necessary details are omitted. Viscosity may be taken as a special and perhaps the worst example. Two tables are given with numerical values for viscosities. Whether these are absolute coefficients in dynes or relative times of transpiration is not stated. They are in reality relative values, the transpiration time of water under the experimental conditions being taken as unity. The numbers in the first table are said to have been "determined with half normal solutions, and referred to *equivalent* quantities of salt." The meaning of this rather redundant sentence is not quite clear. As a matter of fact, the observations were taken with half normal solutions, and referred to normal solutions by means of Arrhenius's formula connecting viscosity with concentration. Nothing whatever is said about the strength of the solutions used for the observations in the second table. They also relate to normal solutions, and were obtained by a similar but not identical method. The most important omission, however, and one occurring in the case of other properties, is that of the temperature of observation. When it is remembered that at 100° the viscosity coefficient of water is only one-fifth what it is at 0°, the influence of temperature on viscosity is apparent. The difficulty in attempting to

compare viscosities has always been the choice of suitable temperatures of comparison—temperatures at which the substances are in comparable conditions. Reference to the original papers shows that the temperature of observation in the examples given was uniformly  $25^{\circ}$ . Whether under such conditions the viscosities obtained are comparable is open to question, and this point should have been discussed before any stress was put upon the figures. Such details as these ought surely to have been noted as necessary accompaniments of the experimental results.

In other directions the same tendency to omit essential particulars is traceable. In describing the series of operations whereby van't Hoff was enabled to apply thermodynamics to solutions, it is not shown that the cycle, as conceived by him, is a reversible one. The whole practical utility of the process depends on its reversibility, for then only does the second law of thermodynamics apply. In connection with this point it is not obvious why the translator should prefer the term "reversible cyclical process" to the time-honoured and compact "reversible cycle." The use, too, of the shortened "cyclical process" as the equivalent of "reversible cycle" is inaccurate.

No doubt the incompleteness mentioned is due to the effort made by the author to make the most of his space. In some cases, however, space might be gained. For example, it is surely excessive to give two pages to Voit's method of obtaining diffusion constants, if it led to results which were "quite erroneous"; or to devote three pages to Planck's deduction of the vapour pressure of dilute solutions, if the fundamental thermodynamical equations are assumed.

Several points which require alteration may be summarized here. On p. 7, van der Waals's equation is given wrongly, a bracket being omitted.  $b$  in the equation is four times the volume of the molecules, not the volume of the molecules, as stated on pp. 7 and 34. No definite mention is made of what the ordinates and abscissæ are in the diagrams on pp. 66 and 67. On p. 70 "differentiating for T" would usually be "differentiating with respect to T." "Narrower" should be "wider" on p. 97, line 15. The expression "200 grams capacity" is used on p. 118. On p. 136, "square root" should be "square." On pp. 186 and 187,  $\frac{d^2}{f'}$  is written for  $\frac{d^2}{f}$ . On p. 237,  $1/b$  should be  $1/v$ . On p. 238,  $\frac{b-B}{1-c}$  is given instead of  $\frac{b-Bc}{1-c}$ .

Mr. Pattison Muir has evidently attempted to give the sense of the original, without confining himself to a literal translation. He has succeeded in making a readable book, although in one or two instances, as in the account of magnetic rotation, the meaning is slightly obscure.

A careful study of this the latest addition to the literature on solution will, we think, confirm what to many has been all along apparent—that solution is in the highest degree a complex process, and that the physical theory errs in treating it as being altogether too simple. Despite the success of this theory, which by establishing a striking analogy has admittedly done much in giving a fresh impetus to investigation, the mechanism of the process is still hidden. The attitude assumed by the upholders of

the physical theory, whereby the presence of the solvent is practically ignored, and analogy regarded as identity, must, of necessity, lead to misconception.

Much more work must be done, and, whatever happens—more attention paid to the function of the solvent, before any adequate theory of solution is possible.

J. W. R.

#### COLOUR BLINDNESS.

*Colour Blindness and Colour Perception.* By F. W. Edridge Green, M.D., F.G.S. (London: Kegan Paul, Trench, Trübner, and Co., 1891.)

IN a work with this title one naturally expects to find that such recognized authorities on the theory of colour perception as Young and Helmholtz are treated with the respect due to their labours and researches. The writer, however, not only refuses to pay homage at the shrine of such masters of natural philosophy, but deliberately devotes a considerable portion of his work to an exposure of the "fallacy of the Young-Helmholtz theory." The preface informs us that the book has been written for the benefit of those who may have to test for colour blindness. To such it will hardly be a recommendation to learn that the theories of Young and Helmholtz are mere fallacies, and that the tests for colour blindness as instituted by Prof. Holmgren are not worthy of the name. The question, of course, arises, What theory are we to adopt relative to colour perception when we have surrendered our allegiance to the theories which Mr. Green denounces? The author answers this query for us by propounding his own doctrine—"an application of the theory of psycho-physical perception, described in my book on 'Memory,' to the phenomena of colour blindness and colour perception." The arguments in support of this theory are based upon the examination of some 116 colour-blind persons, not an over-large number of cases to generalize from, especially when we learn something of the method pursued in the examination. Information afforded by the colour-blind themselves is one of the chief sources of Mr. Green's knowledge respecting colour blindness. He states that he has derived much valuable information from colour-blind persons relating to facts concerning their colour perception. We question much the trustworthiness of data acquired by interviewing colour-blinds as to the phases of their visual infirmity. Yet Mr. Green characterizes this information as trustworthy, and alludes to it as "definite facts of colour blindness, to which any future theory must conform." Many writers on colour blindness have stated that naming colours is a useless and misleading method of examination, because the colour-blind must use the conventional colour names and use them at random. But this reasoning, we are told, is a fallacy, because the colour-blind do not name colours at random, but in accordance with their ideas of colour! Such is the language in which the author disposes of the "fallacy" of Holmgren's wool test. Equally illogical is another of his conclusions: "If, as some persons have said, testing by colour names is useless, then the whole series of colour names is useless."

Prof. Holmgren, it is admitted, has done good service in bringing the subject of colour blindness

forward; and, in consequence, the writer of "Colour Blindness and Colour Perception" regrets that he has to condemn his test. Probably the test will survive the condemnation. Already, according to the figures of Dr. Joy Jeffries, of Boston, some 180,000 persons have by its means been tested expeditiously and effectively. The mention of the American authority on the subject emphasizes the fact that the name of one whose labours in physiology and optics place him in the front rank of English physicists is omitted from the list of English authorities on the subject. Brewster, Herschel, Tyndall, Maxwell, Pole, Abney, Rayleigh, Galton, Nettleship, Bickerton, Frost, and Hogg are recognized as having added to our "knowledge of colour blindness and the dangers arising from the defect." The name of Dr. Brudenell Carter does not appear in the list! The omission is so glaring when the well-known character of Dr. Carter's contributions to the lore of colour blindness is considered, that there must be some reason for it. Doubtless it is because Dr. Carter has been guilty of the heinous crime of championing the theories of Young and Helmholtz that Mr. Green refuses to recognize him as a contributor to our knowledge of the subject under discussion. Dr. Carter once said, in the course of one of the Cantor Lectures: "I read somewhere, and have vainly endeavoured to find again, a denunciation of the 'fallacies of the Young-Helmholtz theory.'" We recommend "Colour Blindness and Colour Perception" to his attention. The so-called fallacies he will there find completely exposed and shattered in a manner most refreshing, and perfectly satisfactory—at least to Mr. Green.

Careful study of Mr. Green's work forces upon one the conclusion that the theories of Young and Helmholtz are "fallacies" for the simple reason that he has failed to understand them aright. Holmgren's tests are no tests because their principle is opposed to the unscientific elaborations of Mr. Green.

An extension of the field of research, together with an honest attempt to *understand* the "fallacies" of Young and Helmholtz, will, we are certain, induce Mr. Green to remove from his book many of its errors and absurdities.

#### A METEOROLOGICAL GUIDE-BOOK.

*Instructions Météorologiques.* Par A. Angot. Troisième Édition. (Paris: Gauthier-Villars et Fils, 1891.)

THE "Instructions Météorologiques," which is the official guide-book for meteorological observers in France, has long been known as a model work of its kind, distinguished by great clearness and sufficiency of detail, while avoiding prolixity. The third edition, lately published, has been revised and extended by M. Angot, whose name is a sufficient guarantee that it maintains the high standard of the original work.

The subject-matter of the present edition has been increased by nearly one-half. One of the chief additions is the description of some of the simpler self-recording instruments, which, it is stated, are coming into general use at the minor French observatories—viz. the sunshine recorder, the recording aneroid, an autographic thermometer on the Bourdon principle constructed by

MM. Richard Frères, and an autographic hair-hygrometer. The section on cloud observation has been recast in accordance with the classification proposed by MM. Hildebrandsson and Abercromby, and, under the heading of "Phénomènes Optiques," halos and the aurora borealis are described. The more common appearance of lunar and solar coronas, though mentioned, is not specially noticed in this section. In a book intended for the instruction of beginners, we think it would have been well to point out the distinction of coronas and halos, since, in our experience, the latter are not infrequently recorded by inexperienced observers, when the former have been the phenomena really observed.

Another subject, treated of for the first time in this edition, is the computation of elevations from the barometric readings, and also from those of the hypsometrical thermometer, the use of which is described at length. In the appendix are given tables for facilitating the reduction of the observations of both classes of instruments.

The patterns of the various instruments, thermometer-shelters, &c., approved by the author of the "Instructions," differ in many respects from those generally preferred by English observers, and in such matters there will, of course, be differences of opinion. The French thermometer-screen, represented on pp. 32 and 33, affords, in our opinion, a better exposure than the Stevenson screen adopted by the Meteorological Societies of England and Scotland, but seems hardly to protect the instruments sufficiently in stormy weather; while the simpler form represented on p. 35 seems quite inadequate in the latter respect, and the method of suspending the maximum and minimum thermometers somewhat flimsy and insecure.

In the text of the work we find little or nothing to which we could take exception, but we think one or two of the figures are open to improvement. The close proximity of the wet and dry bulb thermometers represented in Fig. 16 is hardly compatible with accurate registration of the humidity of the air; and surely the wind-vane represented on p. 73, on the slope of a roof at some indefinite distance below the ridge, is scarcely in an ideally good position, and such as should be put before learners as a standard model for imitation. We would also suggest that, in future editions, a simple form of nephescope, such as Marié Davy's, should be described, together with directions for observing the movement of the clouds. It has long been a matter of surprise that a class of observations so important in themselves and so easily made has been so generally ignored by the writers of such manuals as the present.

#### OUR BOOK SHELF.

*Chambers's Encyclopædia.* New Edition, Vol. VIII. (London and Edinburgh: W. and R. Chambers, 1891.)

We are glad to welcome a fresh instalment of this admirable edition of Chambers's well-known Encyclopædia. It deals with the subjects indicated by words extending from "Peasant" to "Roumelia." Subjects of scientific interest have, as usual, been intrusted to writers who know how to present concisely and clearly the latest results of research. A clear account of the phonograph is given by Mr. Thomas A. Edison; and

Mr. T. C. Hepworth and Mr. W. T. Bashford trace the history and describe carefully the various processes of photography. Mr. J. S. Keltie has an excellent article on Polar exploration, illustrated with a North Polar and a South Polar chart. A short but very good paper on protoplasm is contributed by Mr. J. A. Thomson; and Prof. Sorley makes the most of the few pages set apart for psychology. Rain is discussed admirably by Dr. Buchan, and the rainbow by Mr. W. T. Omond. Reflection and refraction are dealt with by Dr. Alfred Daniell. The main facts relating to the Red Sea are presented by Dr. John Murray; and Dr. Hugh R. Mill sets down all that is likely to be wanted by students who have occasion to refer to the article "River." Altogether, the various papers we have examined may be commended as in every way worthy of the high reputation secured for the present edition by preceding volumes.

*La Place de l'Homme dans la Nature.* By T. H. Huxley. (Paris: B. B. Baillière et Fils, 1891.)

MORE than twenty years ago a French translation of Prof. Huxley's well-known work, "Man's Place in Nature," was published. The translator was Dr. E. Dally. In the present volume this rendering is reissued, and along with it are associated translations of three papers in which Prof. Huxley has presented his ideas on various ethnological subjects. These papers have been translated by Dr. Henry de Varigny, to whom Prof. Huxley expresses thanks for the care he has taken to represent clearly and faithfully the meaning of the original. The volume will be very welcome to French students who desire to understand the methods and tendencies of English scientific thought.

LETTERS TO THE EDITOR.

[The Editor does not hold himself responsible for opinions expressed by his correspondents. Neither can he undertake to return, or to correspond with the writers of, rejected manuscripts intended for this or any other part of NATURE. No notice is taken of anonymous communications.]

Smithsonian Standards for Physical Apparatus.

ON the occasion of a scientific expedition of which I had charge many years ago, the need of common standards of size for the parts of different astronomical and physical instruments was brought forcibly to mind; for the instruments used, while of the latest and best construction, were necessarily dismembered, and then transported in fragments to their scarcely accessible destination by numerous independent bearers; and if any accident happened to any fragment of any piece of apparatus, it was found, as a rule, that the whole was rendered useless, since it could not be replaced from the like parts of other pieces which were spared. The weapons of attack of the little scientific force were, then, in one important respect, far inferior to those of modern warfare, in that there had been no attempt to make their parts interchangeable.

My attention having been drawn to the matter, I was led to examine astronomical and physical instruments in all cabinets accessible to me, with a special view to this feature. I found that, as a rule, no draw-tube, screw, or other piece from one instrument would fit the corresponding parts in any other, there being no attempt to make them interchangeable even where they came from the same maker.

This experience must be confirmed by that of most others, who will probably agree that this is a cause of incessant, but quite avoidable, loss and delay, even where apparatus is used under ordinary conditions, and it has led to inquiry for some scheme which would assimilate different parts of the work, not only of the same, but of different makers. Some of the plans suggested are well matured, and in themselves apparently commendable, but all are too complex, the ambition of the authors being, as a rule, to make them so complete as to cover all possible demands of future progress.

What has been wanted by many others doubtless is some simple and practicable plan for immediate use, which shall yet

be found in accord with the larger scheme which may be under consideration hereafter.

When it fell to me to meet the somewhat varied wants of the Smithsonian Institution by a plan which should at least enable a beginning to be made in the right direction, it seemed that this should be with such simple and general conditions, that common consent to them might almost be counted on, at least on the part of all ready to use the metrical standards.

To provide for the immediate practical wants of this Institution, advice was sought of several of the best instrument makers, and a considerable number of tubes and screws by English, French, and German, as well as American makers were examined to find out the sizes which long-established use in these countries had shown to be practically convenient, and the forms of screws which the best modern practice of scientific instrument makers concurred in; and this having been done, dimensions having a metrical unit, and as near these sizes as practicable, were adopted—not as a finality, but as a beginning.

In the hope that others may consider this very modest attempt to be in the right direction, and that these standards may fall into use for immediate needs, and thus tend to bring about the adoption of that much more complete system of international standards which most will admit to be (at least in the abstract) desirable, I beg leave to inclose a circular which has been sent to all instrument makers employed by this Institution, trusting that you may find it of sufficient interest to bring it to the attention of the readers of NATURE.

S. P. LANGLEY,  
Secretary.

Smithsonian Institution, Washington, D.C., December 16.

*Circular to Instrument Makers.*

In all apparatus used by the Smithsonian Institution a series of standard sizes for metal tubes and for the screws chased on them has been adopted. The metric division is employed, and all tubes ordered are to be finished to some even number of half centimetres in diameter, unless this cannot be done without great difficulty. The series of diameters and corresponding threads to be used is, for a diameter of

10 centimetres,	5 threads to a centimetre.
9 " "	5 " " "
7.5 " "	7 " " "
6 " "	7 " " "
4.5 " "	10 " " "
3 " "	15 " " "

When any new tube has to be ordered, it should be made one of these diameters and chased with one of these threads, if this can in any way be done.

New eye-pieces are to be as far as possible made to fit the three-centimetre plug gauge supplied by Pratt and Whitney, and in fitting them to old work, this size is still to be adapted wherever possible. The Institution is preparing standard plugs and gauges of the diameters given above, and has on hand chases of 5, 7, 10, and 15 threads to the centimetre. All screws have the 60° thread, with flattened top and bottom. These it will supply at first cost to any instrument maker engaged in its work.

Plug gauges are to be had of great accuracy and at moderate cost from several standard tool makers. Those here referred to have been made for the Smithsonian Institution by the Pratt and Whitney Company of Hartford, Connecticut, and are within a limit of error of two-hundred-thousandths of an inch at 62° Fahrenheit. The hobs are from the same makers.

Pigment in Yellow Butterflies.

*Apròpos* of the interesting discussion on comparative palatability and warning colours (NATURE, November 19, p. 53; November 26, p. 78), it may be of interest to your readers if I restate in your columns some of the properties of the yellow pigment contained in the wings of the common brimstone and many other butterflies; the possible significance of which in conferring protective unpalatability is suggested by Mr. Beddard. My paper on the subject, to which Mr. Beddard refers, was read before the Chemical Society in June 1889; but, being more or less of a preliminary nature, it was published only in the abstracts of that Society's proceedings (Abst. Proc. Chem. Soc., vol. v., 1889, p. 117; *vide* also NATURE, vol. xl. p. 335).

The pigment is freely soluble in hot water, though quite insoluble in cold water, and in most organic solvents. Its aqueous solution is strongly acid to litmus; and, though it appears to be quite innocuous to frogs when injected under the skin, it may well be ungrateful to the ranine palate. At the same time it must be noted in this regard that its solubility in the secretions of the frog's mouth is but very slight.

The substance is, as I have shown, undoubtedly a derivative of uric acid, yielding the latter body as one of its products of hydrolysis. It gives the murexide reaction direct. It forms quite definite salts with metals, its compounds with the alkalis being soluble bodies.

Having regard to the wide-spread presence of the body in the scales of diurnal Lepidoptera, I have ventured to call it *lepidotic acid*. In its physical properties it closely resembles mycolic acid, a yellow derivative of uric acid; and, in my original paper, I ventured to suggest a formula for the body. I hope shortly to publish a more complete account of the subject, and to assign a formula to lepidotic acid based upon fuller evidence. Meanwhile, in common with many others of your readers, I am looking forward to the appearance of Mr. Beddard's book. The literature of the subject of animal coloration is not easily accessible, and a text-book thereon will be a valuable acquisition. We have, it is true, the interesting work of Mr. Poulton; but the subject is there treated from what is, perhaps, a somewhat limited standpoint.

F. GOWLAND HOPKINS.

Sir Wm. Gull Research Laboratory,  
Guy's Hospital, December 16.

### The Chromosphere Line $\lambda$ 6676 $\mu$ .

IN response to Father Cortie's implied question as to the identification of this line as belonging to the spectrum of iron, I would refer him to Appendix G of Roscoe's lectures on "Spectrum Analysis" (third edition). It is an extract from a joint paper by Ångström and Thalen, giving a list of several hundred (then) new identifications; among them appears K 654'3, ascribed to iron.

The original memoir was presented to the Stockholm Academy of Sciences in February 1865, and an English translation of it appeared the next year. I am unable to assign any reason why many of the identifications given in this memoir fail to appear in the map published three years later; but they do, and K 654'3 is among the missing.

C. A. YOUNG.

Princeton, N. J., U. S., December 15.

### Grafts and Heredity.

I HAD not thought of grafts when I wrote my paper, and I have to thank Mr. Beeby for reminding me of an excellent illustration of my views; though I cannot gather from his letter whether he considers the "individuality" for which he contends to be represented by matter or force. Adopting his phrase I would apply it to both. The material form, e.g., of the leaf of the scion, is due to molecular motion, set up by a group of forces acting in a way peculiar to the life of the scion; which forces, together with the resulting form, constitute its individuality—something as a man is known by his mental and moral characters as well as by his face.

Now, no two individual plants could be fed more alike than a stock and its grafted scion; since they both receive identically the same food through the roots of the former. All I contend for is, therefore, that it would seem to be more probable that the organic molecules constructed out of this food are all alike, only differently arranged in the leaf of the scion and in that of the stock respectively. These arrangements must be due to molecular forces; while it is difficult to conceive in one's mind how any special kinds of matter can be concerned in the construction of the special forms of leaves; to say nothing of the total want of evidence of the existence of germ- or other plasm.

There is, however, a deeper question still which Mr. Croll asked:—"What determines molecular motion?"<sup>1</sup> He observed that although physical forces are not only interchangeable but can pass into those which, for want of a better expression, we may call vital energies; yet, as he says, nothing we know of in the properties of physical forces can

throw the smallest degree of light upon the above question. There is always, he adds, the "object" which runs through the whole of organized nature; which cannot be accounted for by means of the known properties of physical forces. In concluding his paper he says:—"If one plant or animal differs from another, or the parent from the child [and, we may add, the scion from the stock], it is because in the building up process the determinations of molecular motion were different in the two cases; and the true and fundamental ground of the difference must be sought for in the cause of the determination of molecular motion. Here, in this region, the doctrine of natural selection and the struggle for existence can afford no more light on the matter than the fortuitous concourse of atoms and the atomical philosophy of the ancients." This observation seems to agree with the following remark of Sir J. D. Hooker on the origin of secretory glands of *Nepenthes*:—"The subsequent differentiation of the secretory organs of the pitcher into aqueous, saccharine, and acid would follow *pari passu* with the evolution of the pitcher itself, according to those mysterious laws which re-ult in the correlation of organs and functions throughout the kingdoms of Nature; which, in my apprehension, transcend in wonder and interest those of evolution and the origin of species."<sup>1</sup>

The nearest approach to an answer to Mr. Croll's question is, as it seems to me (though it be but cutting the Gordian knot after all), that there exists a *responsive and adaptive power inherent in living protoplasm* which is called into action by external forces; so that by a change of environment—especially if the old and the new one be strongly contrasted—a plant, as a rule, at once begins to alter its structure so as to re-establish equilibrium with its new surroundings; and further, if these be maintained long enough, the altered structures become fixed and hereditary, while more or less of readaptation can commence again at any time.

We can no more discover the ultimate cause of this power which determines or directs molecular motion in living beings, than we can that of crystallization or gravity, reflex action or instinct. Innumerable facts, however, justify the full recognition of its existence.

To apply this to grafts. It is obvious that, whatever determines the molecular motion in forming the leaf of the scion, it is different from that which determines the molecular motion in forming the leaf of the stock, since the resulting forms of the leaves are different; and it is just this ultimate determining power, which is unknown and apparently unknowable, which characterizes the individuality of the scion on the one hand, and of the stock on the other. Form is but the outward and visible expression of this power. It is this, too, which underlies the responsiveness of protoplasm, and determines a new form in adaptation to, or in equilibrium with, a changed environment.

GEORGE HENSLOW.

### Mental Arithmetic.

THE very simple method of multiplying large numbers, published in NATURE (p. 78) by Mr. Clive Cuthbertson, is mentioned by Pappus, Book II. (ed. Hultsch), 2-29, as an invention of Apollonius. The same method was known to the Hindoos under the name *Vajrabhīyāsa* (Algebra with Arithmetic and Mensuration from the Sanskrit *Brahmagupta* and *Bhāscara*, translated by H. Th. Colebrooke, London, 1817).

The method may be enlarged to multiplying three and even more numbers all at once in the following manner:—

$$\begin{aligned} & (100a_1 + 10b_1 + c_1)(100a_2 + 10b_2 + c_2)(100a_3 + 10b_3 + c_3) = \\ & \quad c_1c_2c_3 \\ & + 10(b_1c_2c_3 + b_2c_3c_1 + b_3c_1c_2) \\ & + 10^2(a_1c_2c_3 + a_2c_3c_1 + a_3c_1c_2 \\ & \quad + b_1b_2c_3 + b_2b_3c_1 + b_3b_1c_2) \\ & + 10^3(a_1[b_2c_3 + b_3c_1] + a_2[b_3c_1 + b_1c_2] \\ & \quad + a_3[b_1c_2 + b_2c_1] + b_1b_2b_3) \\ & + 10^4(a_1a_2c_3 + a_2a_3c_1 + a_3a_1c_2 \\ & \quad + a_1b_2b_3 + a_2b_3b_1 + a_3b_1b_2) \\ & + 10^5(a_1a_2b_3 + a_2a_3b_1 + a_3a_1b_2) \\ & + 10^6a_1a_2a_3. \end{aligned}$$

<sup>1</sup> "What Determines Molecular Motion?—The Fundamental Problem of Nature" (*Phil. Mag.*, July 1872).

<sup>2</sup> Address to the Department of Zoology and Botany of the British Association, Belfast, 1874.



Special example:—

1 2 3 × 4 5 6 × 7 8 9  
 1 2 3  
 4 5 6  
 7 8 9

- First figure.—3 × 6 × 9 = 162 . . . . . 2
- Second figure.—16 + 2 . 6 . 9 + 5 . 9 . 3 + 8 . 3 . 6 = 403 . . . 32
- Third figure.—40 + 1 . 6 . 9 + 4 . 9 . 3 + 7 . 3 . 6 + 2 . 5 . 9  
 + 5 . 8 . 3 + 8 . 2 . 6 = 634 . . . . . 432
- Fourth figure.—63 + 1 . (5 . 9 + 8 . 6) + 4 . (2 . 9 + 8 . 3)  
 + 7 . (2 . 6 + 5 . 3) + 2 . 5 . 8 = 593 . . . . . 3432
- Fifth figure.—59 + 1 . 4 . 9 + 4 . 7 . 3 + 7 . 1 . 6  
 + 1 . 5 . 8 + 4 . 8 . 2 + 7 . 2 . 5 = 395 . . . . . 53432
- Sixth figure.—39 + 1 . 4 . 8 + 4 . 7 . 2 + 7 . 1 . 5 = 162 . . . 253432
- Seventh and eighth figures.—16 + 1 . 4 . 7 = 44 . . . . . 44253432

K. HAAS.

Vienna, VI., Matrosengasse 8.

The Migration of the Lemming.

HAVING resided during the summer months for more than twenty years on the plateau from which the migrations of the Norwegian lemming are supposed by many to take their origin, I can speak from personal observation. Some years ago I had the honour to read a rather lengthy paper before the Linnean Society on these animals, and, with one exception, to which reference will be presently made, I am happy in having nothing to alter or recant. The increase of the Lemmings is not cumulative, but rather periodic, as indeed is usual among the voles as well as among many other forms of life. The migrations are not caused by insufficient food *now*, whatever they may formerly have been, and this is evident from the fact that the swarms pass through, but do not exhaust the fertile districts which they encounter on their pilgrimage. Nor are they affected by any personal struggles between these most pugnacious of animals, for the young litters, when reared, go singly on the journey from which none have ever been observed to return. They do not follow the watershed, and they do not always migrate to the west—an error into which I was betrayed by trusting to common report and insufficient personal experience. But they do go straight. It is well known that the eyes of the lemming are so placed on the top of the head as to render it impossible for the animal when swimming, to discern any object not far above the plane of its horizon. On a calm morning last summer, I often placed my boat in the path of the swimmers, and noticed that they crossed my lake in an absolute "bee-line," and that they could not discern my presence until the angle subtended by the boat was infinitely higher than that of the opposite shore. This latter migration was south-east, and in the late autumn the steamer on Lake Mjosen made its way through thousands of these hapless wayfarers; whilst, still later, large numbers were to be seen close to Christiania; but I venture to prophesy that none will be found in that neighbourhood next year, nor, for the matter of that, in Heimdaalen itself, though it is obvious that some must remain. Probably the explanation of these apparently capricious and suicidal migrations may be that they are the result of hereditary instinct, which formerly was of service if not necessary to the species. The straight course which they pursue must be owing to the sense of direction common to migrants, and I would hazard the conjecture that the changes of destination may be due to an instinct which, owing to its present inutility, is gradually diminishing in precision and intensity. W. DUPPA-CROTCH.

Asgard, Richmond, December 24.

The Recent Earthquake in Japan.

DANS la lettre de M. J. Milne, Tokio, 7 novembre, sur le tremblement de terre du Japon du 28 octobre, 1891 (NATURE, xlv. 127), il y a entre autres un fait intéressant: c'est la mise en oscillation de l'eau d'un bassin de 60 pieds de longueur sur 25 pieds de profondeur. Il est rare que dans un tremblement de terre l'eau des étangs ou des lacs soit mise en mouvement; le rythme des vibrations du sol ne correspond pas, le plus souvent,

au rythme de l'oscillation de l'eau. Dans le cas actuel, les vagues ayant atteint une hauteur de 3 à 4 pieds, il est certain que l'eau a pris un mouvement de balancement.

Le formule d'un tel mouvement d'oscillation pendulaire, si le bassin a un fond horizontal, est:

$$t = \frac{2l}{\sqrt{gh}}$$

$$l = 60 \text{ pieds} = 18'29\text{m.},$$

$$h = 25 \text{ pieds} = 7'62\text{m.},$$

$$t = 4'2 \text{ secondes de temps.}$$

Il serait intéressant de savoir si le rythme des vibrations du tremblement de terre à Tokio a correspondu à une durée aussi lente; ou peut-être à la moitié de cette durée, soit 2'1". Ce serait déjà des vibrations extraordinairement lentes pour un tremblement de terre. F.-A. FOREL.

Morges, 12 decembre.

ON THE VIRIAL EQUATION FOR GASES AND VAPOURS.

ALTHOUGH I had, some time ago, written to Lord Rayleigh to the effect that I did not intend to prolong the discussion of this question, it may perhaps be expected that I should say a few words with reference to Prof. Korteweg's paper in the last issue of NATURE.

I do not agree with Prof. Korteweg's statement that Van der Waals's method, if it could be worked out with absolute rigour, would give the same result as the direct method. There is but one way of dealing with the virial equation:—if we adopt it at starting we must develop its terms one by one, and independently. In this connection I may refer to Lord Rayleigh's statement (NATURE, 26/11/91): "It thus appears that, contrary to the assertion of Maxwell,  $\beta$  is subject to correction." I cannot admit that  $\beta$  is "corrected"; it is not even changed either in meaning or in value. It is introduced as, and remains (at the end of any legitimate transformations of the equation) the value of the pressure on the containing vessel. This, of course, depends upon what is going on in the interior. Other terms in the virial equation, which happen to have the same factor, may be associated with  $\beta$  for convenience; they assist in finding its value, but they do not change its meaning, nor do they "correct" it.

I do not think that much aid can be obtained by analogy, at least in the present question, from the case of one-dimensional motion. For the latter may be looked on as virtually the to-and-fro motions between fixed boundaries of a number of particles, each of which keeps its speed for ever unchanged, except at the moments when two *instantaneously* pass through one another. From this point of view the result of Lord Rayleigh and of Prof. Korteweg follows at once. Make the particles mere points, and diminish their free range by the sum of their original lengths, and everything will go on practically as before. Can a corresponding statement be made for three dimensions? Again, there is in the one-dimensional case a perfectly arbitrary set of speeds, which remains unchanged:—there is nothing analogous to the beautiful statistical distribution of Clerk-Maxwell. And what would be the result if molecular forces were introduced?

Prof. Korteweg seems not to have noticed the following sentence in my second letter to Lord Rayleigh (NATURE, 29/10/91, p. 628):—"The true mode of getting a cubic here . . . [*v*. in Prof. Korteweg's notation,

$$\beta_1 v = \frac{1}{3} \Sigma (mu^2) \left( 1 + \frac{\beta}{v} \right) ]$$

is to write  $\beta/(v - \gamma)$  instead of  $\beta/v$ . This can, to a certain extent at least, be justified; the other method

can not." I had, originally, added a sentence to the effect that, if  $\gamma$  be taken equal to  $\beta$ , Van der Waals's result would at once be obtained. But I struck it out as irrelevant, because the discussion turned mainly upon the question of the value of the free path at a volume nearly equal to the critical volume. Here Van der Waals expressly recognized that his  $b$  must be diminished in value. From my point of view,  $\beta$  (having been determined once for all) is unchangeable; while  $\gamma$  is essentially less than  $\beta$ , possibly even negative.

Prof. Korteweg takes a different view, and says that the "true" formula is obtained by the process above hinted at:—i.e. by putting (with the preceding notation)  $\gamma = \beta$ .

4. Prof. Korteweg speaks of the equation written above as "quite worthless." But, in all this discussion, where the rival expressions differ only by the introduction or rejection of terms of the order  $\beta^2/v^3$ ; which, according to Prof. Korteweg, make an equation "true" or "quite worthless" as the case may be:—are we not introducing an error, of that order at least, in calmly writing

$$\dot{p}_1 = \dot{p} + \frac{a}{v^2},$$

instead of some such expression as

$$\dot{p}_1 = \dot{p} + \frac{a}{v(v+a)}?$$

We have, fortunately, one practical test at hand to help in the decision of such questions. The introduction of the form last written, certainly more likely to be approximate than the first, renders the "quite worthless" equation capable of at least fairly representing the results of Andrews. The "true" equation, we know, does not represent them.

P. G. TAIT.

Edinburgh, 21/12/91.

## ON THE RELATION OF NATURAL SCIENCE TO ART.<sup>1</sup>

### I.

WE are assembled to-day in annual commemoration of a man whose marvellous breadth of view and extraordinary variety of interests are each time a fresh surprise to us. It seems incredible that the same hand could have penned the "Protogea" and the State-paper adjudging the Principality of Neuchâtel to the King of Prussia; or that the same mind could have conceived the infinitesimal calculus and the true measure of forces, as well as the pre-established harmony and the "Theodicea." A closer examination, however, reveals a blank in the universality of his genius. We seek in vain for any connection with art, if we except the Latin poem composed by Leibnitz in praise of Brand's discovery of phosphorus. We need hardly mention that his "Ars Combinatoria" has nothing to do with the fine arts. In his letters and works, observations on the beautiful are few and far between; once he discusses more at length the pleasure excited by music, the cause of which he attributes to an equable, though invisible, order in the chordal vibrations, which "raiseth a sympathetic echo in our minds." However, the world of the senses had little reality for Leibnitz. With his bodily eye he saw the Alps and the treasures of Italian art, but they conveyed nothing to his soul. He was indifferent to beauty; in short, we never surprise this Hercules at Omphale's distaff.

The same neglect, at least of sculpture and painting,

<sup>1</sup> An Address delivered by E. du Bois-Reymond, M.D., F.R.S., at the annual meeting of the Royal Academy of Sciences of Berlin in commemoration of Leibnitz, on July 3, 1890. Translated by his daughter. This Address was first printed in the weekly reports (*Sitzungsberichte*) of the Berlin Academy, then in Dr. Koderberg's *Deutsche Rundschau*, and lastly it was published as a separate pamphlet by Veit and Co., at Leipzig, 1891.

strikes us in Voltaire, who as polyhistorian can in some measure compare with Leibnitz. We are obliged to descend as far as the third generation—that is, to Diderot in France, to Winckelmann and Lessing in Germany—before we meet with a decided interest in the fine arts, and an appreciation of the part they play in the progress of civilization.

The period thus defined, though it excels in science, shows with few exceptions a falling-off in the fine arts. On considering the historical development of these two branches of human productiveness, we find no correspondence whatever between their individual progress. When Greek sculpture was in its prime, science scarcely existed. True, Lionardo's gigantic personality, which combines the immortal artist with the physicist of high rank, towers at the beginning of the epoch generally known in the history of art as the Cinquecento. Still, he was too far in advance of his age in the latter capacity to be cited as an example of simultaneous development in art and science; so little that Galilei was born the day of Michael Angelo's death. The mutual development of art and science at the commencement of our century is, I believe, merely a casual coincidence; moreover the fine arts have since been at the best stationary, whereas science strides on victoriously towards a boundless future.

In fact, both branches differ too widely for the services rendered to science by art, and *vice versa*, to be other than external. "Nature," Goethe very truly observed to Eckermann—little thinking how harshly this remark reflects on part of his own scientific work—"Nature allows no trifling; she is always sincere, always serious, always stern; she is always in the right, and the errors and mistakes are invariably ours." Fully to appreciate the truth of this, one must be in the habit of trying one's own hand at experiments and observations, while gazing in Nature's relentless countenance, and of bearing, as it were, the tremendous responsibility incurred by the statement of the seemingly most insignificant fact. For every correctly interpreted experiment means no less than this: whatever occurs under the present circumstances, would have occurred under the same conditions before an infinite negative period of time, and would still occur after an infinite positive period. Only the mathematician, whose method of research has more in common with that of the experimenter than is generally supposed, experiences the same feeling of responsibility in presence of Nature's eternally inviolable laws. Both are sworn witnesses before the tribunal of reality, striving for knowledge of the universe as it actually is, within those limits to which we are confined by the nature of our intellect.

However, there is a compensation for the philosopher, labouring under this anxious pressure, in the consciousness that the slightest of his achievements will carry him one step beyond the highest reached by his greatest predecessor; that possibly it may contain the germ of vastly important theoretical revelations and practical results, as Wollaston's lines contained the germ of spectral analysis; that, at any rate, such a reward is not only in the reach of a born genius, but of any conscientious worker; and, finally, that science, by subduing Nature to the rule of the human intellect, is the chief instrument of civilization. No real civilization would exist without it, and in its absence nothing could prevent our civilization, including art and its master-works, from crumbling away again hopelessly, as at the decline of the ancient world.

This consciousness will also make up to the philosopher for the thoughtlessness of the multitude, who, while enjoying the benefits thus lavished upon them, hardly know to whom they owe them. The country rings with the name of every fashionable musical *virtuoso*, and cyclopedias insure its immortality. But who repeats the name of him who achieved that supreme triumph of the inventive intellect—to convey through a copper wire across

far-stretching countries and over hill and dale the sound of the human voice as though it spoke in our ear?

"Life is earnest, art is gay": this saying of Schiller's remains as true if we substitute science for life. Art is the realm of the beautiful; its productions fill us with an enjoyment, half sensuous, half intellectual; it is, therefore, a realm of liberty in the widest sense. No rigid laws are enforced in it; no stern logic binds the events of the present to those of the past and future; no certain signs indicate success; blame and praise are distributed by the varying taste of ages, nations, and individuals, so that the glorious Gothic church architecture came to be derided by the eighteenth century. In art, the definition of genius as a talent for patience does not hold good. Its creations, once brought forth in a happy hour of revelation, stir our souls with elementary force, and scorn all abstruse explanations, subsequently forced upon them by art criticism. Whoever accomplishes such a feat also ministers in a sense to the cares and troubles of humanity. Unfortunately, the nature of things does not allow such fruit to ripen at all seasons; at one time, in one direction, the culminating point will be reached, and then age after age will strive in vain to emulate the past. The finest æsthetic theories can neither carry the individual beyond the limits of his own natural powers, nor retrieve the fortunes of a declining period. Of what use has been the recent strife in the artistic world between naturalists and idealists? Has it protected us from the frequently almost intolerable extravagances of the latter? There is an attraction in every boldly advanced novelty which the common herd is unable to resist, and which will invariably triumph till antiquated ideas are somehow supplanted by fresh ones, or by the lofty lure of some irresistibly superior personality. Nor can science in the stricter sense come to the aid of art; and thus, strangers at heart, without materially influencing each other, each seeks its own way: the former advancing steadily, though irregularly; the latter slowly fluctuating like a majestic tide. Those unfamiliar with science are apt to recognize the supreme development of our mental faculties in art alone. Doubtless this is a mistake; yet human intellect shines brightest where glory in art is coupled with glory in science.

We may notice something here which is similar to what occurs in practical ethics. The more corrupt the morals of an age or nation, the more we find virtue a favourite topic. The flood of æsthetic theories rises highest when original creative power is at its lowest ebb. Lotze, in his "History of Æsthetics in Germany,"<sup>1</sup> gives a wearying and discouraging account of such fruitless efforts. Philosophers of all schools have rivalled in abstract definitions of the essence of beauty. They call it unity in multiplicity, or fitness without a purpose, or unconscious rationality, or the transcendent realized, or the enjoyment of the harmony of the absolute, and so forth. But all these properties, which are supposed to constitute the beautiful, have no more to do with our actual sensation of it than the vibrations of light and sound with the qualities they bring to our perception. Indeed, it would be vain to attempt to find one term equally fitted to describe all the varieties of the beautiful: the beauty of cosmos as contrasted with chaos, of a mountain prospect, a symphony, or a poem, of Ristori in Medea, or a rose; or even, taking the fine arts alone, the beauty of the Cologne Cathedral, the "Hermes" of Praxiteles, the Madonna Sistina, a picture of still-life, a landscape, a genre piece, or a Japanese flower design; not to mention the questionable custom which permits us in German to speak of a beautiful taste or a beautiful smell. Let us rather admit that here, as so often, we meet with something inexplicable in our organization; something inexpressible, though not the less distinctly

felt, without which life would offer a dull and cheerless aspect.

In an essay of Schiller's there is a disquisition on physical beauty.<sup>2</sup> He distinguishes between an architectural beauty and a beauty which emanates from grace. I attacked this æsthetic rationalism, to which the last century was strongly addicted, twenty years ago on a similar occasion in a lecture on Leibnitz's ideas in modern science. I ventured to assert that "the attraction which physical beauty exerts on the opposite sexes can as little be explained as the effects of a melody."<sup>3</sup> On reflection, it seems, indeed, incomprehensible why one distinct shape, which, according to Fechner, might be represented by a plain algebraic equation between three variables, should please us beyond a thousand other possibilities. The reason can be traced from no abstract principle, no rules of architecture, not even from Hogarth's line of beauty. A year after this remark was made, Charles Darwin published his "Descent of Man," in which the principle of sexual selection, only cursorily treated in the "Origin of Species," is fully expounded, and pursued in all its bearings. I remember vividly how, in a discussion with Dove as to the necessity of admitting a vital force, he embarrassed me by the objection that in the organic world luxury occurs, for example, in the plumage of a peacock or a bird of Paradise; while in inorganic nature Maupertuis's law of the minimum of action precludes such prodigality. Here was a solution to the problem, allowing that one might attribute to animals a certain sense of beauty. The gorgeous nuptial plumage displayed by male birds may have been acquired through the preference of the female for more highly ornamented suitors, a progeny of constantly increasing brilliancy of colouring being thus obtained. Male birds of Paradise have been observed to vie in showing off their beauty before the females during courtship. The power of song in nightingales might be attributed to the same cause, the female in this case being more susceptible to the charms of melody than to those of brilliant colouring. Darwin goes on to observe that, in the human race likewise, certain sexual characteristics, such as the imposing beard in man and the lovely tresses in woman, might have been acquired through sexual selection.<sup>3</sup> It is a well-known fact that, by the repeated introduction of handsome Circassian slaves into aristocratic Turkish harems, the original Mongol type in many cases has been remarkably ennobled. And carrying the same principle further, we may find therein an explanation for the fascination which female beauty has for man. According to our present views, the first woman was not made of a rib taken out of the first man—a process fraught with morphological difficulties. It was man himself who, in countless generations, through natural selection, fashioned woman to his own liking, and was so fashioned by her. This type we call beautiful, but we need only to cast a glance at a Venus by Titian, or one by Rubens—let alone the different human races—to recognize how little absolute this beauty is.

If one kind of beauty could be said to bear analyzing better than another, it is what might be termed mechanical beauty. It is noticed least, because it escapes all but the practised eye. This kind of beauty may belong to machines or physical apparatus, each part of which is exactly fitted to its purpose in size, shape, and position. It answers more or less to the definition of "unconscious rationality," our satisfaction

<sup>1</sup> "Ueber Anmuth und Würde."

<sup>2</sup> The author's "Collected Addresses, &c.," vol. i., pp. 49, 50, Leipzig, 1836.

<sup>3</sup> The author is not unaware of Mr. Wallace's attack on Darwin's explanation of the brilliant plumage of male birds by the females' preference, and of the discussion arisen between him and Messrs. Poulton, Pocock, and Peckham. This was not the proper place to enter into it, the less so as, whatever may be its outcome, the author's conclusion from the theory of sexual selection would remain unaltered.

<sup>1</sup> Munich, 1868.

evidently proceeding from an unconscious perception of the right means having been employed to combine solidity, lightness, and, if necessary, mobility, with the greatest possible profit in the transmission of force, and the smallest waste of material. A driving-belt is certainly neither attractive nor unattractive; but it pleases the "*visus eruditus*" to see a connecting-rod thickened from the ends towards the middle, where it has to bear the greatest strain. Of course this kind of beauty is of recent origin. I remember Halske telling me that, as regards the construction of physical and astronomical instruments, it was, to his knowledge, first understood and established as a principle in Germany by Georg von Reichenbach in Munich. Berlin and Munich workshops produced instruments of perfect mechanical beauty at a time when those supplied by France and England were still often disfigured by aimlessly ornamented columns and cornices, unpleasantly recalling the impure features of Rococo furniture and architecture.

I forget which French mathematician of the last century, in sight of the cupola of St. Peter's at Rome, tried to account for the sense of perfect satisfaction it gives to the eye. He measured out the curves of the cupola, and found that, according to the rules of higher statics, its shape supplies the exact maximum of stability under the given circumstances. Thus Michael Angelo, guided by an unerring instinct in the construction of his model (the cupola was not erected till after his death), unconsciously solved a problem the true nature of which he could hardly have understood, and which was even beyond the reach of the mathematical knowledge of his age. Apparently, however, there are several roots to this equation of beauty; at least there is one other type, for which I quote the cupola of Val de Grâce in Paris, which, if not as imposing, is quite as gratifying to the eye, as Michael Angelo's.

It will be observed that in this case mechanical beauty becomes part of the art of architecture; and instances of this kind are daily growing more frequent, our modern iron structures being more favourable to its display than stone buildings. In the Eiffel Tower we see mechanical beauty struggling with the absence of plastic beauty. On this occasion it was probably revealed for the first time to many who hitherto had no opportunity of experiencing its effect. It is certainly not wanting in the new Forth Bridge. There is no doubt, however, that in stone structures too, together with much that pleases from habit or tradition, there are certain features which evidently attract through mechanical beauty—such as the outline of the architectural members of a building, or the gentle swelling and tapering of the Doric column towards the top, and its expansion in the echinus and abacus; and there are others which offend a refined taste through the absence of this beneficial element, such as the meaningless ornamentations of the Rococo style.

Even in organic nature mechanical beauty prevails to such an extent that it transforms many objects into a source of delight and admiration to the initiated, which are naturally repulsive to the untrained eye. Anatomists recognize it with pleasure in the structure of the bones, especially of the joints. In their opinion the "Dance of Death" outrages good taste from more reasons than because it differs from the classical conception of death. Mechanical beauty was already perceived by Benvenuto Cellini in the skeleton, much to his credit; and but for our imperfect knowledge, it would invest with its glory every organic form, down to the inhabitants of the aquarium, even under the very microscope. According to Prof. Schwendener, even plants are constructed on the same principle of fitness combined with thrift; and something of this we feel at sight of a spreading oak-tree, proudly distending its vigorous branches towards air and sunlight.

Again, our appreciation of the forms of animals, especially of noble breeds, is greatly influenced by mechanical beauty. The greyhound and the bulldog, the full-bred race-horse and the brewer's dray-horse, the Southdown and the Merino sheep, the Alpine cattle and the Dutch milch-cow, all are beautiful in their kind; even though a bulldog or a Percheron may appear ugly to the uninitiated, because in each the type of the species has been modified to the utmost degree of fitness.

Though science is unable, as we have seen, to check the occasional decline of art and inspire it with fresh vigour, yet it renders invaluable services of a different kind to artists, by increasing their insight, improving their technical means, teaching them useful rules, and preserving them from mistakes. I do not allude to anything so primitive as the manufacture of colours or the technique of casting in bronze; the less so, as, curiously enough, our modern colours are less durable than those of entirely unscientific ages, and the unsurpassed thinness of the casting of Greek bronzes is regarded as a proof of their authenticity. Nor does it seem necessary to recall the notorious advantages of this kind for which art is indebted to science. Linear perspective was invented by Lionardo and Dürer—artists themselves. It was followed by the laws of reflection—unknown to ancient painters, as would appear from the Pompeian frescoes of Narcissus—and by the geometrical construction of shadows. The rainbow, which had better not be attempted at all, has been sinned against cruelly and persistently by artists, in spite of optics. Statics furnished the rules of equilibrium, so essential to sculptors. Aerial perspective, again, owes its development to painters chiefly of northern climates.

But to this fundamental stock of knowledge the progress of science has added various new and important acquisitions, which philosophers, some of first-rate ability, have endeavoured to place within the reach of artists. The great masters of by-gone ages were taught by instinct to combine the right colours, as women of taste, according to John Müller, always know how to blend the right shades in their dress; and Oriental carpet-weavers have not been behindhand with them in that respect. But the reason why they unconsciously succeed was not revealed till the elder Darwins, Goethe, Purkinje, John Müller, and others, called into existence a subjective physiology of the sense of sight. A member of this Academy, Prof. von Brücke, in his "Physiology of Colours"<sup>1</sup> and "Fragments from the Theory of the Fine Arts in relation to Industrial Art,"<sup>2</sup> treats these subjects with such intimate knowledge as could only be obtained by one who enjoyed the rare advantage of combining physiological learning with an artistic education acquired in his father's studio. In France, Chevreul pursued similar aims. Even Prof. von Helmholtz, in his popular lectures, has devoted his profound knowledge of physiological optics, to the service of art, which already owes him important revelations on the nature of musical harmony. Amongst other things, he explained the relation between the different intensities of light in objects of the actual world and those on the painter's palette; and pointed out the means by which the difficulties arising therefrom may be overcome.<sup>3</sup> Thus painters, as von Brücke remarks, have it in their power to reproduce the dazzling effect of the disk of the sun by imitating the irradiation—a defect of our visual perception the true nature of which was recognized by von Helmholtz. An example of this, interesting through its boldness, is the lovely Castell Gandolfo in the Raczyński gallery.

There are so many and striking instances of such imperfections of the human eye that, notwithstanding its marvellous capabilities, von Helmholtz has observed that "he would feel himself justified in censuring most severely

<sup>1</sup> 2d edition, Leipzig, 1887.

<sup>2</sup> Leipzig, 1877.

<sup>3</sup> Prof. von Helmholtz, "Collected Essays and Addresses," vol. ii., Brunswick, 1884.

the careless workmanship of an optician who offered him for sale an instrument with similar defects, and that he would emphatically refuse to take it." The eye being the chief organ of artists, its defects are of great importance in art and its history, and artists would do well to inform themselves, not only on these defects in general, but more particularly on those which they, in their own persons, are subject to; for, as Bessel remarked of astronomical instruments, "an error once well ascertained ceases to be an error."

Our conception of the stars as stars, in the shape adopted symbolically by decorative art, is caused by a defect of the eye closely related to irradiation; stars being luminous spots in the sky without rays, as they actually appear to a privileged few. Prof. Exner, whose line of thought we shall repeatedly cross in the course of these reflections, justly remarks that to this imperfection the stars conferred by Sovereigns as marks of distinction owe their origin, and star-fishes their name, even since Pliny's time. The different varieties of halo, however, are more probably free-born children of our fancy—from the Byzantine massive golden disk, down to the mild phosphorescence proceeding from holy heads and in Correggio's "Night" from the entire child, which illumines the scene with a light of its own. According to Prof. Exner, glories of the latter description are derived from the radiance which surrounds the shadow of one's own head in the sunshine on a dewy meadow, and which in fact has always been compared to halos in religious pictures. This phenomenon even misled Benvenuto Cellini into the pious delusion that it was a gift granted him individually from above, and a reflection of his visions, such as Moses brought down from Mount Sinai.<sup>1</sup>

Certain otherwise quite inexplicable peculiarities which disfigure the later works of the distinguished landscape-painter Turner have also been traced to defects of the eye by Dr. Richard Liebreich.<sup>2</sup> Clouded lenses or a high degree of astigmatism might easily lead a painter to distort or blur objects he was copying from nature. Donders's stenopæic spectacles or cylindrical spectacles, as the case might be, would prove as useful to such an artist as concave glasses to the shortsighted.

The singularities of another English painter, Mulready, are accounted for by Dr. Liebreich through discoloration of the lens from old age. Another defect of the eye—colour-blindness—ought to be mentioned here, which in its milder forms is of frequent occurrence, and even belongs to the normal condition of the eye on the borders of the field of vision. It corresponds in the domain of hearing to the want of musical ear. Colour-blindness was known long ago, but has been inquired into with redoubled zeal latterly, partly with regard to its general connection with chromatics, partly on account of its serious practical consequences in the case of sailors, railway officials, and, as Dr. Liebreich adds, of painters. Both colour-blindness and want of ear are inborn defects, for which there is no remedy. A colour-blind artist is, however, better off than a musician without an ear, if such a one were imaginable, for, even if he neglected the modelling stick and the chisel, he might still seek his fortune in the designing of cartoons.

It is difficult to determine the particular point where optical knowledge ceases to be of use to artists. None will repeat having studied the laws of the movement of the eyes, the difference between near and distant vision, and the observations on the expression of the human eye contained in John Müller's early work on "Comparative Physiology of Sight." Yet it must be admitted that a painter may paint an eye exceedingly well without ever having heard of Sanson's images, which cause the soft lustre of a gentle eye as well as the fierce flash of an

angry one; as little as the blue sky of a landscape painter will gain by his knowledge of the yellow brushes in every great circle of the heavenly vault which passes through the sun—a phenomenon which has remained unnoticed for countless ages, but has grown familiar to physiologists since Haidinger's discovery.

One point, however, where physicists seem to me not to have been sufficiently consulted, is the much-debated question of polychrome in ancient statues and architecture, and whether it should be adopted by modern art or not. Physical experiments teach that very intense illumination causes all colours to appear whitish; in the spectrum of the sun, seen immediately through the telescope, the colours vanish almost entirely, nothing remaining except a light yellow hue in the red end. As the colours grow whitish the glaring contrasts are softened, they blend more harmoniously. In the open air, therefore, our eyes are not shocked by the scarlet skirt of the *contadina*, which recurs almost as invariably in Oswald Achenbach's Campagna landscapes, as the white horse in Vouvermann's war scenes. The Greek statues and buildings may have looked well enough with their glaring decorations under the bright southern sky on the Acropolis or in the Poikile; in the dull light of our northern home, above all in closed rooms, they are somewhat out of place.

In another direction Wheatstone has added valuable information to the knowledge of painters and designers with his stereoscope. It demonstrates the fundamental difference which distinguishes binocular vision of near objects from monocular vision, as well as from binocular vision of objects so far removed that the distance between the eyes vanishes as compared with their distance. An impression of solidity can only be obtained by each eye getting a different view of an object, the two images being fused into one, so as to appear solid. A painter can therefore only express depth by shading and aerial perspective; he will never be able to produce the impression of actual solidity on his canvas. While Wheatstone's pseudoscope exhibits the unheard-of spectacle of a concave human face, Helmholtz's telestereoscope magnifies, as it were, the space between the eyes, and resolves a far-off range of woods or hills without aerial perspective into its different distances. Finally, Halske's stereoscope with movable pictures confirms old Dr. Robert Smith's explanation of the much-debated circumstance that the sun and moon on the horizon appear larger by almost a fifth of their diameter than when seen in the zenith, and reduces the problem to the other question: why the vault of the sky appears to us flattened instead of hemispherical.

However, the almost contemporary invention of photography was destined to be of vastly greater importance to the fine arts. It had always been the dream of artists as well as physicists to fix della Porta's charming pictures—a dream the realization of which did not seem quite impossible since the discovery of chloride of silver. One must have witnessed Daguerre's invention, and Arago's report of it in the Chamber of Deputies, to conceive the universal enthusiasm with which it was welcomed. Daguerre's method, being complicated and of restricted application, was soon cast into the shade by the one still essentially practised at the present day. However, it is worth recording that, when the first specimens, imperfect as they were, reached us from England, no one foresaw the immense success in store for Talbotypes; on the contrary, the change from silver-coated plates to paper impregnated with the silver salt was received with doubt, and considered a retrogression.

Thus photography entered on its marvellously victorious career. With respect to art it promptly fulfilled what Arago had promised in its name. It not only facilitated the designing of architecture, interiors, and landscapes, and rendered the *camera clara* unnecessary

<sup>1</sup> "Vita di Benvenuto Cellini, scritta da lui medesimo," libro primo, cxxvii.  
<sup>2</sup> "Turner and Mulready: the Effect of certain Faults of Vision on Painting, &c.," London, 1889.

even for panoramas, but also furnished many valuable hints with regard to light and shade, reflection and *chiaroscuro*, and the general means of reproducing as closely as possible on a level surface the raised appearance of solid forms. A competent judge of both arts might find it an interesting task to ascertain what share photography has had in the origin of the modern schools of painting, and in the manner of impressionists and pleinairists. It further taught landscape-painters to depict rocks and vegetation with geological and botanical accuracy, and to represent glaciers, which hitherto had been but rarely and never successfully attempted. It caught and fixed the changing aspect of the clouds, though only yielding a somewhat restricted survey of the heavens. It aided portrait-painters without exciting their jealousy; for, unable to rival them in representing the average aspect of persons, it only seized single, often strained and weary expressions, rendering almost proverbial the comparison between a bad portrait and a photographed face; nevertheless it supplied them on many occasions with an invaluable groundwork, lacking nothing but the animating touch of an artist's hand.

However, the recent progress of photographic portraiture claims the attention of artists in more than one respect. Duchenne and Darwin called into existence a new doctrine of the expression of the emotions; the former by galvanizing the muscles of the face, in order to imitate different expressions, the latter by inquiring into their phylogenetic development in the animal series. Both presented artists with photographs which quickly consigned to oblivion the copies hitherto employed for purposes of study in schools of art, dating chiefly from Lebrun; even the sketches in Signor Mantegazza's new work on "Physiognomy and Mimics" will scarcely enter into competition. On Mr. Herbert Spencer's suggestion, Mr. Francis Galton subsequently solved by the aid of photography a problem, which was previously quite as inaccessible to painters as the representation of an average expression to photographers. He combined the average features of the face and skull of a sufficient number of persons of the same age, sex, profession, culture, or disposition to disease or vice, in one typical portrait, which exhibits only those characteristic forms common to their various dispositions. This was effected by blending on one negative the faint images of a series of persons belonging to the same description. In the same manner, Prof. Bowditch, of Harvard Medical School, Boston, obtained the representative face or type of American students of both sexes, and of tramway conductors and drivers. In the latter instance, the intellectual superiority of the conductors over the drivers is plainly visible. How Lavater and Gall would have relished this!

Of course the average expression of a single person might be procured by similar means, if it were worth while summing up on the same plate repeated photographs of different expressions. Instantaneous photography, however, furnishes a welcome substitute for the average expression, by seizing with lightning swiftness the changing phases of the human countenance in their full vivacity. Here, again, pathology places itself at the disposal of art. M. Charcot has found that photographs of the convulsions and facial distortions of hysterical patients resemble our classical representations of the possessed. Raphael's realism in this respect is perhaps the most curious of all, being so much at variance with his idealistic nature. In the possessed boy of the "Transfiguration," a cerebral disease can be almost safely inferred from the Magendie position of the eyes; and the circumstance, recently observed in New York, that the left hand is depicted in a spasm of athetosis, would accord well with this diagnosis.<sup>1</sup>

(To be continued.)

<sup>1</sup> Sachs and Petersen, "A Study of Cerebral Palsies," &c., *Journal of Nervous and Mental Diseases*, New York, May 1890.

### TELESCOPIC OBJECTIVES.<sup>1</sup>

IT is a frequent source of disappointment to observers, especially beginners, to find that their instruments fail to answer to the tests which are so commonly found in astronomical text-books. It may be that the instrument in question is really an imperfect one; but if it be the work of a maker of repute, it is more probable the fault lies in the absence of proper adjustment, more especially if, for some reason or other, no responsible person is able to superintend the final fixing in position. The information hitherto published on the subject of adjustment, and the phenomena which accompany the various defects of an objective, is very scanty; and observers of all classes will therefore welcome the appearance of the little book recently issued by Messrs. T. Cooke and Sons, the well-known firm of telescope makers. The book is the best testimony that one could wish for as to their thorough knowledge of their business, and it abundantly demonstrates that they are worthy of the confidence which astronomers have long placed in them. The benefit of their wide experience is now available to all, and observers need no longer remain in doubt as to the quality of their objectives, or of the course to be pursued in tracing the defects to their proper sources.

For full particulars of the methods to be adopted we must refer our readers to the book itself, but many of the points touched upon are of great interest, considered simply as optical phenomena, and a brief reference to some of them may not be out of place.

It is a matter of common knowledge that, owing to the undulatory nature of rays of light, the image of a luminous point, such as a star, must always be a small disk, the diameter of which varies in inverse proportion to the aperture of the objective. This "spurious disk" is surrounded by a series of diffraction rings, which gradually diminish in intensity away from the centre.

The calculations of Sir George Airy<sup>2</sup> show that the angular radii of the rings, in circular measure, are given by the formula  $\frac{\lambda n}{2\pi e}$ , where  $\lambda$  is the wave-length of the light-rays in question,  $e$  the radius of the objective, and  $n$  a constant which depends on the distance from the centre. The first dark ring occurs when  $n = 3.83$ , the second when  $n = 7.14$ , and the third when  $n = 10.17$ . Hence, the angular radius of the first dark ring, which is really the boundary of the spurious disk, may be easily derived from the formula  $\frac{3.83 \times \lambda}{2\pi e}$ , or  $\frac{1.22\lambda}{2e}$ .

The rings are brightest when  $n = 5.12, 8.43$ , and  $11.63$ , with intensities respectively about  $1/57, 1/240$ , and  $1/620$  of that at the centre.

If  $s$  be the angular radius in seconds of arc, as viewed from the centre of the objective, the formula becomes

$$n = \frac{2\pi e s}{\lambda} \sin i'';$$

and if  $\lambda$  for mean rays be taken as '000022 inch,

$$n = 1.3846e \times e s.$$

For the first dark ring, therefore,

$$s = \frac{3.83}{1.3846e} = \frac{2.76}{e}.$$

Messrs. Cooke put these expressions in the form—

$$\text{Angular diameter of first dark ring in circular measure} = \frac{2 \times 1.22\lambda}{A},$$

$$\text{Linear diameter of first dark ring} = \frac{2F \times 1.22\lambda}{A};$$

where  $A$  = aperture, and  $F$  = focal length.

For a square aperture the conditions are different, and

<sup>1</sup> "On the Adjustment and Testing of Telescopic Objectives." (T. Cooke and Sons, Buckingham Works, York.)

<sup>2</sup> "Undulatory Theory of Optics," 1877 edition, p. 80.

the size of the first dark square is given by the formula  $\frac{2\lambda F}{A}$ .

Some interesting facts given by Messrs. Cooke show the remarkable agreement between the theoretical and observed values of these diameters. "A 6-inch objective, of 91 inches focal length, was directed to a bright star, and the objective cut down, in the first place, to a square aperture, 1.5 inches diameter. The mean of four measurements gave the diameter of the first dark ring (in this case square in shape) as .0027 inch, while the formula  $\frac{2\lambda F}{A}$  (where  $\lambda = 1/45600$  inch) gives .00266 as the theoretical value. A circular aperture, diameter 1.22 inches, was then placed in front of the objective, when the mean of four measurements gave a diameter of .0039 for the first dark ring, while the formula  $\frac{2F \times 1.22\lambda}{A}$  gives a value of .0040" (p. 31). "The diameter of the first dark ring, as depicted with the whole aperture of 6 inches in use, was also measured as nearly as its minute size would allow, the measurement obtained ranging about .0008 (subject to an error of perhaps 10 per cent.), while the value given by the formula  $\frac{2F \times 1.22\lambda}{A}$  is .00081" (p. 32).

As the spurious disk fades away into the first dark ring, its apparent diameter will depend on the intrinsic brightness of the star observed, and also to some extent on irradiation. Hence the necessity for measuring the rings, and not the "disks" themselves.

An important fact follows from the application of these considerations, for on the apparent diameter of the spurious disk depends the dividing power of the objective. If the diameter of the star disk—which may, on the average, be taken as half that of the first dark ring—be greater than the distance between the components of a double star, the telescope must obviously fail to divide it, no matter what may be the power of the eye-piece employed. "In all objectives having their focal lengths equal to fifteen times the aperture, the linear diameter of the spurious disk may be said to average .0004 inch, or about 1/2500 inch. With 6 inches aperture this corresponds to an angular diameter of 0.9 second, and in a 12-inch aperture to 0.45 second. So these respectively represent the dividing powers of such apertures upon double stars of average brightness" (p. 31). For similar apertures, the values given by Dawes for stars in which both components are of the sixth magnitude are 0".76 and 0".38 respectively. To reduce the star disks to the extent necessary for the separation of the components of the spectroscopic binary  $\beta$  Aurigæ (the angular distance being about 0".005), an object-glass no less than 80 feet in diameter would be required.

The images of a star with the diffraction rings as yielded by a sensibly perfect objective are shown in Fig. 1.<sup>1</sup> Fig. 1, *a*, represents the focused disk and ring system seen under a high magnifying power; 1, *b*, and 1, *c*, are sections of the cone of rays taken very near to and on opposite sides of the focus, also seen with a high power; and 1, *d*, is a section taken about  $\frac{1}{4}$  of an inch on either side of the focus, and viewed with a moderate power.

Before this perfection of image can be realized, we gather that the objective must satisfy the following conditions:—(1) The optic axes of the flint and crown glass lenses should be coincident. (2) This common axis should pass through the centre of the eye-piece. (3) The dispersions of the flint and crown should neutralize each other for the most visible rays of the spectrum. (4) There should be no spherical or zonal aberration. (5) The lenses should be free from astigmatism.

The second of these adjustments is practically the only one over which the observer himself has any control, and he must remain contented with the means of ascertaining

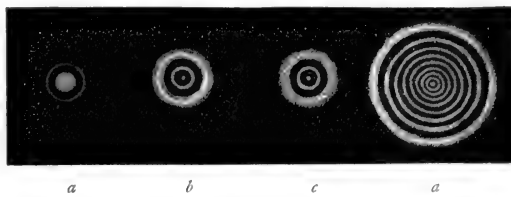

FIG. 1.—Diagrams showing spurious disk and diffraction rings seen with a perfect objective.

how far his objective satisfies the remaining conditions enumerated.

The process of testing an objective is considerably complicated by the imperfections of the eye as an optical instrument. Its want of achromatism when the full aperture of the pupil is used may frequently lead the observer astray in making observations in which colour effects are to be noticed. This defect is demonstrated, as pointed out on p. 14, by the fact that coloured fringes are observed to surround the image of a star seen in the open field of a reflector, of the perfect achromatism of which there can be no question. A sound practical hint accompanies this statement. The use of a power from 50 to 70 times the aperture in inches is recommended for purposes of testing, in order that the pencil of rays entering the pupil may be reduced; for if the power be equal to or less than the quotient of the diameter of the objective and the diameter of the pupil, the full aperture of the pupil is utilized, and the defect is consequently at its maximum.

Colour-blindness, of which no mention is made by Messrs. Cooke, is also common, and it is obvious that no colour-blind eye is competent to make tests depending on colour phenomena.

Astigmatism, too, is not an uncommon defect, the rays falling along one diameter of the lenses of the eye being refracted in a greater or less degree than those falling along the direction at right angles. Oculists combat this by supplying compensating astigmatic lenses as spectacles; and unless such compensation be perfect, an astigmatic eye must clearly be disqualified from making some of the test observations.

Another complication arises on account of atmospheric dispersion (p. 18). This, of course, is at its maximum for stars on the horizon, and the image of such a star would appear to have a red fringe on the upper and a green or blue fringe on the lower side, even in the most perfect telescope, unless a compensating eye-piece be used. Hence the importance of selecting stars of considerable altitude for purposes of adjustment and testing.

Further, the Huyghenian and Ramsden eye-pieces, which are almost universally used, are not achromatic in the strict sense of the term, and the eye-piece used for testing should therefore not be selected at random (p. 13).

Bearing these facts in mind, one may proceed to test the adjustments referred to.

(1) Any difference in the position of the axes of the component parts of the objective will cause the combination to act somewhat in the manner of an object-glass prism, such as is used in photographing stellar spectra, and the image of a star seen under such maladjustment will appear as a spectrum. The red end of the spectrum will obviously lie on the side towards which the flint is displaced with regard to the crown lens, an effect which is most noticeable when the eye-piece is racked within the focus (p. 17).

<sup>1</sup> The diagrams are reproduced with the permission of Messrs. Cooke.

(2) This adjustment is technically called "squaring on," and is usually provided for in telescopes over 3 inches in aperture. If the optic axis of the objective does not pass through the centre of the eye-piece, the diffraction rings which are seen when the star is out of focus, will appear oval, and the focused image will be fan-shaped (p. 8). This follows from the fact that we are dealing with an oblique section of the cones of rays from the object-glass, and the rings will be most expanded and dimmest on the side which is furthest from the object-glass.

Fig. 2, *a*, represents the rings seen when the star is out of focus in the case of an objective seriously out of square, and Fig. 2, *b*, the corresponding focused image.

(3) Ordinary objectives should be so corrected that all the rays between C and F of the spectrum are brought to a common focus, these being the rays to which the



FIG. 2.—Appearances observed when the objective is out of square.

retina is most sensitive. When this is done the objective is "over-corrected," and the rays less refrangible than C are brought to a shorter focus, while those more refrangible than F are focused at a greater distance outside. Hence, supposing a white star like Vega is observed, the focused image should be surrounded by an almost imperceptible blue fringe. A little way within the focus the image should show a reddish nucleus, and outside the focus a bluish centre should be observed. The effect of the colour of the star observed must be carefully guarded against (p. 16), and an eye-piece of sufficient power should be employed, for the reason already stated.

A good method of testing for achromatism is to focus the image of a star on the slit of a spectroscope. If the image be perfectly achromatic, as in the case of a reflector, the spectrum seen will be a line of uniform thickness. Any departure from this will be indicated by local



FIG. 3.—Appearances due to spherical aberration.

widenings of the spectrum. With an ordinary objective, the spectrum should be a narrow line from C to F, widening out at each end.

(4) The absence of proper correction for spherical aberration produces very interesting features in the diffraction rings, some of which are admirably shown by the diagrams which are reproduced in Figs. 3, *a*, and 3, *b*. These represent sections of the cone of rays within and outside the focus respectively in the case of a lens in which there is *positive* aberration—that is, in which the rays from the outer parts of the object-glass come to a shorter focus than the central rays. In the first figure the concentration of light in the outer ring is the chief characteristic, while in the second the central ring is relatively brighter.

Zonal aberration, in which different parts of the objective have slightly different foci, modify the ring systems in a very remarkable fashion. In this case, the rings will not gradually diminish in intensity, but will vary according to the degree of imperfection. Figs. 4, *a*, and 4, *b*, show a good example of this, being sections taken within and outside the focus respectively.

(5) The effect of astigmatism in the objective will be

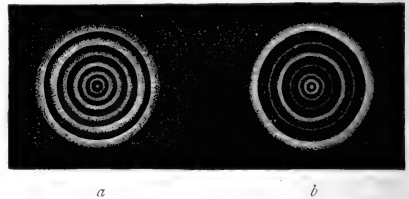

FIG. 4.—Effects of zonal aberration.

to produce ellipticity in the rings, a very decided example of which is shown in Fig. 5.

Fig. 5, *a*, is a section taken within the focus, and Fig. 5, *b*, a section taken at the same distance outside. The combined effects of an astigmatic objective and an astigmatic eye may obviously be very variable.

Other causes may also operate in the modification of



FIG. 5.—Elliptic rings produced by astigmatism.

the diffraction rings, and some good examples are given. The effects of the flexure of a lens supported on three points, for instance, are admirably shown in Fig. 6, *a*. Those who have seen photographs in which bright stars appear with their conventional rays will now have no difficulty in understanding their origin. They depend simply upon the distortion of the lens or mirror with which



FIG. 6.—Diagrams showing effects due to (*a*) flexure; (*b* and *c*) strain in cell; (*d*) veins in objective.

the photograph was taken, and the number of rays will correspond to the number of points of support.

An objective which is strained in its cell, but properly squared on, may produce a distortion of the rings similar to that shown in Fig. 6, *b*. A more violent case of mechanical strain is shown in Fig. 6, *c*, and the presence of veins of unequal refractive power may affect the rings somewhat in the manner shown in Fig. 6, *d*.

A. FOWLER.



## NOTES.

A NUMBER of very remarkable letters and hitherto unedited memoirs of the great Swedish chemist Carl Wilhelm Scheele, who died in 1786, are to be published under the direction of Baron Nordenskiöld. The work will fill about 500 pages octavo, of the same size and print as Wilson's "Life of Henry Cavendish" (London, 1851). The Baron is considering the question of bringing out an Anglo-American edition of the work. As editor he may not be quite impartial, but he is persuaded that in importance and interest the book will be unsurpassed in historico-chemical literature. He hopes also to obtain permission to consult some of the papers on chemistry left behind by Cavendish. For instance, he would like to know if the date assigned by the Rev. Vernon Harcourt to Cavendish's researches on arsenic (Report of the Ninth Meeting of the British Association, held at Birmingham, 1839, p. 50) is exact, or if any error affects the determination of the date. Where are these papers at present deposited? Are they accessible to a foreign student?

WE understand that the Professorship of Descriptive Geometry, Mechanical Drawing, Machinery, and Surveying, in the Royal College of Science, Dublin, will almost immediately become vacant by the retirement of Prof. Pigott, we regret to say on the ground of ill-health. The salary of the chair is £400, rising to £500 a year with a share of fees. The appointment rests with the Lord President of the Council, and applications, with testimonials, should be addressed to the Secretary, Science and Art Department, London.

THE death of C. X. Vaussenat, the Director of the Observatory on the Pic du Midi, is announced. Quite recently he received from the Société Nationale d'Agriculture de France its large gold medal for the eminent services rendered by his observatory to agriculture. The idea of building an observatory on the Pic du Midi was due to General de Nansouty, but in working out the plan the General owed much to the enthusiastic co-operation of M. Vaussenat. When the institution was made over to the State, General de Nansouty became honorary director, M. Vaussenat effective director. M. Vaussenat was an engineer, and had devoted much time to the study of geology.

PAUL HUNFALVY, whose death is recorded by Austrian journals, was recognized as the most eminent Hungarian ethnographer and philologist. He was the author of many papers on the relation of the Magyar language to the Finnish, but especially to the Ugrian languages, and on the original seats of the Finnish-Ugrian peoples. In a book describing his travels in the Baltic Provinces he had much that was interesting to say about the Estonians; and to a series of works on the races of the Austro-Hungarian Monarchy he contributed a volume on "The Hungarians or Magyars."

AN Ethnographical Exhibition is to be held at Prague in 1893. The objects exhibited will relate to the life of the Slavonic population of Bohemia, Moravia, and Silesia.

THE U.S. Patent Office proposes to exhibit at the Chicago Exposition a comprehensive array of models to illustrate the progress of mechanical civilization. One group of models will show the progress of the printers' art from Gutenberg's invention to the latest rotary perfecting and folding printing press, capable of turning out newspapers at the rate of many thousands per hour. Other groups will show the development of the steam-engine, sewing-machine, agricultural machinery, applications of electricity, &c.

ACCORDING to *Electricity*, a Chicago journal, Messrs. Siemens and Halske, the well-known German firm of electrical engineers and manufacturers, propose to outdo all their competitors in the extent of their exhibit at the World's Fair. Herr Carl Vogel,

the managing director of the firm, recently went to Chicago to make the necessary arrangements. He asked for a special building, but the Committee on Electricity decided that space could not be granted outside the regular buildings. The Department of Electricity has, however, offered to Messrs. Siemens and Halske 20,000 square feet in the electricity building, and 10,000 square feet in the power house, and it is thought that this offer will be accepted.

A POST-GRADUATE course of study in electrical engineering, lasting two years, has for some time been in successful operation at the School of Mines, Columbia College, New York. An undergraduate course of four years in the subject has just been established at the same institution. Admission will be given only to those who pass the entrance examinations which are necessary for the courses in mining, engineering, civil engineering, chemistry, architecture, &c. The first two years of the new course will cover the preparatory work in mathematics, physics, chemistry, mechanics, and other subjects required for admission to the post-graduate course. During the last two years students will receive a thorough training in electrical engineering proper. The course will begin in October 1892. Those who satisfactorily pass the examinations at the end of the course will receive a degree of electrical engineer.

THE Journal of the Society of Arts is printing a very interesting series of Cantor Lectures, by Mr. A. P. Laurie, on pigments and vehicles of the old masters. Mr. Laurie has for some years been studying the literature of this subject; and, having tested the statements contained therein, as far as he could, by experiments in the laboratory, he thinks he has succeeded in clearing up a few points and answering a few questions. He deals with the subject under three heads: (1) the preparation of the painting surface; (2) the pigments, their preparation and properties; (3) the mediums.

THE Adelsberg Cave, with all its recently-discovered side-caverns, has lately been carefully surveyed, in accordance with the instructions of the Austrian Minister of Agriculture, Count Falkenhayn. In the course of the operations some very beautiful parts of the cave, which could formerly be reached only with the greatest difficulty, were made easily accessible. An elaborate plan has been deposited in the office of the Minister of Agriculture, and it is hoped that copies of it, on a reduced scale, may be issued to the public.

MR. W. BRANDFORD GRIFFITH, writing from Iver, St. Elizabeth, Jamaica, says that a very perceptible, not to say alarming, shock of earthquake was felt throughout Jamaica early on the morning of October 27. At Kingston the shock was felt at 1.35 a.m., and the disturbance then seemed to be travelling in a direction north-east by north.

MR. G. JERVIS gives in the December number of the *Mediterranean Naturalist* an interesting sketch of the geology of Pantelleria, to which attention has recently been called by the submarine eruptions off its coast. Mr. Jervis refers to the fact that, like Ischia, Pantelleria possesses thermo-mineral springs, highly mineralized, which might become of much therapeutic and economic importance. The Romans and Arabs, if not earlier peoples, seem to have thoroughly appreciated the value of these springs; but in modern times they have been neglected. Mr. Jervis suggests that the Governor of Malta should despatch one or two medical men to Pantelleria at the public expense at the proper season to study the curative effects of the thermo-mineral waters, and to plan the most practical and efficient method of sending patients there during the summer. It is thought that many military men, suffering from a variety of chronic complaints incident to their rough mode of life and

rapid transfer from one climate to another, would be glad to visit the island, especially if they could combine to obtain steam communication occasionally with Malta.

THE Meteorological Office of Paris has recently published its *Annals for the year 1889*, in three volumes, as in previous years. Volume i., under the title of *Memoirs*, contains a treatise by M. Fron on the course of the thunderstorms during the year, accompanied by daily charts. M. Moureaux has published the details of the magnetic observations made at Saint Maur, with a summary of the disturbances; eight plates reproduce exactly the photographic curves of the most remarkable disturbances. M. Angot gives the results of the first simultaneous observations made at the Central Meteorological Office and on the Eiffel Tower. The diurnal variation of pressure at the summit of the tower shows that the first minimum (4h.-5h. a.m.) is much more pronounced in all months at the summit than at the base, and appears to occur rather later. The first maximum (9h.-10h. a.m.) is much less important at the summit, especially during the summer months, and also appears to occur later. The second minimum (2h.-3h. p.m.) is much less important at the summit, and the second maximum (about 10h. p.m.) is rather more pronounced at the summit than at the base. The temperature of the air at the summit of the tower during the night differs constantly from that of St. Maur by less than the normal value; during the day, on the contrary, the difference of temperature is much greater between the two stations than the normal value. The wind, during all months, has a diurnal variation quite different from that at the Central Office; the maximum occurs at the middle of the night, while the minimum occurs at about 10h. a.m., and rather later in winter. Vols. ii. and iii. contain respectively the general observations and the rainfall values at the various stations.

THE idea of a "weather lexicon" has been recently developed by Herr Seemann (*Met. Zeit.*), using the records of the Hamburg Naval Observatory. The design is to find in a collection of daily weather charts a condition of the air over Europe resembling that of the day for which a prognosis is to be formed, and note the former sequence of weather, as throwing light on what the coming weather is likely to be. Herr Seemann uses in his lexicon all the Hamburg weather charts of the ten years 1876 to 1885. Each chart is briefly characterized; the pressure differences in three directions (north-west, south-west, and north-east from Hamburg) being indicated for each day; also wind observations in the Alps and in Norway. The days are arranged according to the amounts of difference in pressure between Hamburg and Stornoway; this gives nine groups. Under these are formed sub-groups according to the differences between Hamburg and Biarritz; and under these, others based on the differences between Hamburg and Helsingfors. The classification is further extended to wind direction. The idea seems a useful one, and experience will doubtless show in what directions the proposed method may be most advantageously modified and developed.

THE *New York Nation* of December 17, mentions a rather striking example of the injustice which is sometimes done to American men of science by the McKinley Tariff. A professor in one of the academies near Boston, returning from Europe, brought with him a microscope for his own use in the biological department. Under section 686 of the tariff law, which includes in the free list "professional books, implements, instruments, and tools of trade, occupation, or employment, in the actual possession at the time of persons arriving in the United States," he might very reasonably have expected to import this without duty, but at the steamship dock in Boston a heavy duty was demanded. He appealed to the collector, but was permitted to carry the instrument away without payment of the

tax only upon his making a gift of it to the institution with which he was connected. Even then the trouble was not quite at an end. The Principal of the Academy had to take an oath that he accepted the instrument as a free gift to the school, for its sole use, and not to be sold or given away.

In a paper contributed to the current number of the *Journal of the Franklin Institute*, Mr. John Birkinbine, President of the American Institute of Mining Engineers shows that during the last thirty years the United States has increased its relative production of one ton of pig-iron for every thirty-two inhabitants to one ton of pig-iron for every seven and one-half inhabitants. The Middle States have advanced from one ton for every eleven inhabitants to one ton for every two and one-quarter inhabitants. With regard to Pennsylvania, he notes that while its population of less than 3,000,000 inhabitants in 1860 had increased to 5,250,000 in 1890, its pig-iron product of but little over 500,000 in 1860 was augmented to nearly 4,250,000 in 1890. In 1860, Pennsylvania produced one ton of pig-iron for every five inhabitants; in 1870, it made one ton of pig-iron for every three and three-quarters inhabitants; in 1880, one ton was made for every two and one-half inhabitants; and in 1890 one ton for every one and one-quarter inhabitants. Until 1692, no iron was made in Pennsylvania, and even then so little was produced that the exact locality where it was prepared is not known. As a practical producer of iron, the State's history does not begin until 1716, sixty-one years after the establishment of the industry in Massachusetts. Pig-iron was not made in Pittsburg before 1859, but in thirty-one years the magnificent industry in Allegheny County advanced so steadily that in 1890 a total of 1,337,309 gross tons was produced.

MR. CHARLES R. KEYES contributes to the new instalment of the *Proceedings of the Academy of Natural Sciences*, Philadelphia, a valuable paper on fossil faunas in Central Iowa. In a paper on the lower coal measures of Central Iowa, in 1883, 35 genera and nearly 60 species were mentioned. The figures are now increased to 51 and 84 respectively, and many forms have not yet been thoroughly investigated. The interest, however, lies not so much in the numerical increase of the species as in the information imparted in regard to both the geological and geographical range of the various types within and beyond the limits of the State; and in the exhibition, in many forms, of structural features which have hitherto been more or less obscure. A recent geological study of the locality has disclosed a large number of stations where animal life was at one time very prolific. Several new horizons have been definitely made out, on account of which the distribution in time of the various forms is capable of being traced with greater accuracy than has hitherto been possible.

A THIRD edition of Mr. Charles A. Cutter's "Rules for a Dictionary Catalogue," has been issued by the U.S. Bureau of Education. Mr. Cutter is librarian of the Boston Athenæum, and his experience has, of course, been of the greatest service to him in the working out of his system, which is well worthy of the attention of librarians. The objects of a "Dictionary Catalogue," as he defines them, are (1) to enable a person to find a book of which either (a) the author, (b) the title, (c) the subject, is known; (2) to show what the library has (d) by a given author, (e) on a given subject, (f) in a given kind of literature; (3) to assist in the choice of a book (g) as to its edition (bibliographically), (h) as to its character (literary or topical).

PROF. E. D. COPE announces in the *American Naturalist* the discovery of a new species of frog in New Jersey. It is a most distinct species, and about the size of the wood frog (*Rana sylvatica*). It is not nearly related to any species of the genus

Prof. Cope obtained five adult and two half-grown individuals, and had two other adults almost within his grasp, but they escaped him. The specimens agree nearly in size, the chief differences being observed in the amount of dark blotching of the belly and the regularity of the markings on the inferior side of the femur. The specimens were found in a "cut-off" of a tributary of the Great Egg Harbour River, in Atlantic county, New Jersey. The water is stagnant, and is well grown with *Nymphæas*, *Utricularia*, and *Sphagnum*. The frogs did not display any considerable powers of leaping or swimming, but concealed themselves with much ease within the aquatic vegetation. Prof. Cope did not observe any voice. In the same locality he observed the *Rana virescens* and *clamata*. The "cut-off" is in the woods, and he found no individuals in similar situations in the open country, nor any along running water in the woods. The oversight of this conspicuous species, as Prof. Cope says, is a curious circumstance.

ACCORDING to a statement in the Toronto *Monetary Times*, grape-culture is becoming an important industry in Ontario. The centre of the vine cultivation is between Grimsby and St. Catharines. In Essex, especially on Pelee Island, experience has shown that grapes can be profitably grown. Some local experiments show a probability that in the near future the county of Norfolk will be added to the vine land of the province. The quality of the grapes grown has of late been greatly improved, and so prolific are the vines that growers have this season in many instances had to be content to take one and a half cents a pound for good samples. Grape culture is rapidly extending, especially in the county of Welland. This year's price for grapes is perhaps about as low as they can be grown at a profit, but it looks as if the supply might in future outstrip the demand.

In the report on his work during 1890, lately issued, Mr. R. L. Jack, the Government Geologist of Queensland, refers to a collection of geological specimens forwarded by the Administrator of the Government of British New Guinea. The collection demonstrated (1) the presence of gold, topaz, and beryl in the bed of the Fly River; (2) the presence, within the drainage area of the river, of (a) stratified rocks in an unaltered condition, including sandstones, clays, limestones, and lignites; (b) metamorphosed stratified rocks, including slates and greywackes; and plutonic and igneous rocks. A number of concretionary ironstone nodules probably indicated the presence of metalliferous lodes. Some fossil corals, in limestone pebbles probably of Mesozoic age, from the first and second rapids of the Fly River, have been sent for identification to Mr. Robert Etheridge, Palæontologist to the Geological Survey of New South Wales and the Australian Museum. A second collection of rocks from Toulon Isle, Port Hennessy, Red Point, Teste Isle, Rossel Isle, &c., was examined by Mr. Maitland. Among these were grits, sandstones, shales, limestones, basalts, granites, and quartz containing a minute quantity of gold.

M. CARTAILHAC contributes to the current number of *L'Anthropologie* an excellent abstract of an elaborate paper by A. J. Evans on a late Celtic urn-field at Aylesford, Kent. Other contributions are a fresh instalment of T. Volkov's interesting account of marriage rites and usages in Ukraine; a paper by E. T. Hamy on the country of the troglodytes; and an essay, also by E. T. Hamy, on the ethnographical work of Nicolas-Martin Petit.

FOR experimental proof of the principle of Archimedes, M. Paquet (*Journ. de Phys.*) recommends the following general method: Into any vessel, V, is brought the body A (which is the object of experiment), with attached wire by which it can be conveniently hung. The vessel is then filled up with water;

then A is lifted out, leaving a vacancy equal to its volume. The vessel V is now put into one scale of a hydrostatic balance, and the body A hung under it; then weights are put into the other scale till equilibrium occurs. If now the balance is lowered till A dips wholly in the water of a lower vessel V', the disturbed equilibrium can be restored by simply filling up the vessel V with water.

It has been long known that glass is attacked and dissolved in small quantities by ordinary water. This dissolving process Herr Pfeiffer has recently sought to prove and measure by change in the electric conductivity of the water (*Ann. der Physik*). He measured the increase of conductivity undergone by 1 cubic centimetre of pure water when it has been in contact for one hour with one square centimetre of glass surface, and concluded that the amount of glass dissolved at 20° C. was 1 to 2 millionths of a milligram. He found, too, that with temperature rising arithmetically, the growth of solubility is considerably more rapid than that of a geometrical series; that the increase of conductivity of the water for a given kind of glass under like conditions is a characteristic constant; and that later, when a certain quantity of alkali is dissolved, further action involves a dissolving also of silicic acid, and the salts then formed may cause a decrease of conducting power.

BARON NORDENSKIÖLD communicated to the December meeting of the Royal Swedish Academy of Science the fact that he has discovered notable quantities of uranium in the asphaltic or rather anthracitic minerals, accompanying the magnetic and hæmatite iron ores in Sweden. A large block of so-called "anthracite" from Norberg, for instance, leaves, when burned, ashes (13 per cent.) which contain about 6 per cent. of uranium; a similar mineral from Dannemora left, when burned, ashes containing 4 per cent. of uranium. The Norberg mineral also contains cerite and gadolinite oxides, although in small quantities, and it is remarkable that the mixture of gadolinite oxide (yttria, ytterbia, &c.) from this new *provenance* has the normal atomic weight of 255.6 (for  $R_2O_3$ ).

TETRA-IODIDE of carbon,  $CI_4$ , has been obtained in large ruby-red crystals by M. Moissan by the action of his recently-prepared boron iodide,  $BI_3$ , upon carbon tetrachloride. Boron iodide is a substance crystallizing from solution in carbon bisulphide in colourless tabular crystals which melt at 43° to a liquid boiling at 210°. It is a substance of great chemical activity, reacting with considerable energy with a large number of substances, as described in *NATURE*, vol. xliii. p. 568. When it is brought in contact with carbon tetrachloride, double decomposition occurs in the cold, with a large evolution of heat boron chloride and carbon tetra-iodide being formed.

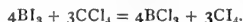

The best mode of operating is to heat the two substances, the crystals of boron iodide and excess of dry redistilled carbon tetrachloride, in a sealed tube for one hour at a temperature of 80°-90°. Next morning the tube is found to contain large crystals of carbon tetra-iodide, which appears to be produced in theoretical quantity. After opening the tube, the crystals are drained, washed with a solution of bisulphite of soda in order to remove the last traces of iodine, and finally dried *in vacuo*. When the red crystals thus obtained are heated to 100° in an exhausted sealed tube, they slowly sublime into the colder portion of the tube in magnificent brilliant red crystals very much resembling the artificial rubies prepared by MM. Freymy and Verneuil. The reactions of carbon tetra-iodide are somewhat interesting. When heated in a current of hydrogen at a temperature about 140°, it is reduced to iodoform,  $CHI_3$ .

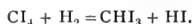

When the crystals are placed in an atmosphere of chlorine they at once liquefy, and the liquid becomes hot. The products are carbon tetrachloride and liquid chloride of iodine, ICl, which latter gradually volatilizes away in the form of the chloride, ICl<sub>3</sub>.

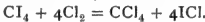

When heated gently in dry oxygen, it becomes decomposed into iodine and carbon, which latter burns away to carbon dioxide upon slightly raising the temperature. Melted sulphur reacts with carbon tetra-iodide with considerable violence; vapour of iodine is evolved, carbon deposited, and iodide of sulphur formed. If, however, powdered sulphur is warmed with carbon tetra-iodide to 50°, iodide of sulphur and carbon bisulphide are produced. Phosphorus acts with great energy upon it, forming compounds which are still undergoing investigation. Sodium and potassium react with incandescence, an alkaline iodide and free carbon being produced. Mercury and silver likewise attack it at the ordinary temperature, and very rapidly upon warming. Warm hydrochloric and hydriodic acids attack the crystals rapidly, with formation of iodoform and liberation of vapour of iodine. A particularly interesting reaction is that with fluoride of silver. When a quantity of this salt is placed in a solution of carbon tetra-iodide in carbon tetrachloride warmed to 50°, a regular evolution of gaseous carbon tetra-fluoride occurs.



This reaction affords the readiest means yet discovered of preparing carbon tetrafluoride.

THE additions to the Zoological Society's Gardens during the past week include a Vervet Monkey (*Cercopithecus lalandii* ♀) from South Africa, presented by Mr. J. Parr; a Bonnet Monkey (*Macacus sinicus* ♂) from India, presented by the Rev. W. P. Beckett; a Black-faced Kangaroo (*Macropus melanopus* ♀) from Australia, presented by Mr. P. Clark; two Red-crested Finches (*Coryphospingus cristatus*) from South America, presented by Commander W. M. Latham, R.N., F.Z.S.

OUR ASTRONOMICAL COLUMN.

THE SECULAR VARIATION OF LATITUDES.—The *American Journal of Science* for December contains a paper on secular variations of latitudes, read by Prof. George C. Comstock at the Washington meeting of the American Association for the Advancement of Science. The determinations of the latitude of Greenwich made from the time of Flamsteed (1693) to now—that is, over a period of very nearly two centuries—indicate a very appreciable progressive diminution. But as the observations were made with five different instruments, and are affected, to an uncertain extent, by various sources of error, no definite conclusion can be drawn from them. In the cases of the latitudes of Pulkowa, Königsberg, Washington, and Madison, however, Prof. Comstock thinks there is definite evidence of a change of latitude, and from an examination of numerous absolute observations, and a reduction of recorded star-places, he arrives at the data contained in the following table:—

Station.	Longitude (from Greenwich).	Annual Variation of Latitude.	Computed Annual Variation.
Pulkowa ...	30°3' E. ...	- 0'006 ...	- 0'007
Königsberg ...	20°5' E. ...	- 0'003 ...	- 0'000
Washington ...	77°0' W. ...	+ 0'042 ...	+ 0'044
Madison ...	89°4' W. ...	+ 0'043 ...	+ 0'041

A least square solution of the observed data was made to determine the most probable direction and amount of motion of the Pole. The result was 0"·044 along the meridian 69° W. of Greenwich. The values contained in the last column of the above table were computed from these elements. For the systematic investigation of the motion of the Pole it is suggested that two stations in about the same latitude, but having longitudes about 70° W. and 110° E. respectively, should have their

latitudes simultaneously determined by zenith telescope observations of the same pairs of stars. "An annual motion of the Pole of 0"·045 will alter the difference of latitude of these stations by twice this amount per year, giving a change in the difference of latitude amounting to 1" in eleven years—a quantity which cannot possibly escape careful observation with the zenith telescope or prime vertical transit. If similar observations be made 20° east of Greenwich, they will furnish the best obtainable data for determining the direction of motion of the Pole." All sources of systematic error can be eliminated by the adoption of such a method, and our knowledge of secular variations of latitude, as important to the geologist as to the astronomer, will be of a more definite character than at present.

THE ROTATION OF VENUS.—Herr Löschardt sends us a paper on Schiaparelli's hypothesis as to the period of rotation of Venus, presented by him to the Vienna Academy of Sciences on March 12, 1891. He criticizes the conclusions drawn by Schiaparelli from observations made by others and himself, and points out that the observations made by Denning in 1881 favour the old rotation period of 23d. 21m. rather than one of 224 days. Herr Löschardt has made a number of drawings of the markings on the planet shown by his 3-inch refractor at Nákófalva, and the discussion of them gives support, on the whole, to Cassini's value of the rotation period. The chief reasons which led to this conclusion are the differences between Perrotin's observations and those made at Nákófalva at different hours in the same day, the circular form of polar patches, and the ellipsoidal distribution of the atmosphere, which is said to be the result of swift rotation.

STARS HAVING PECULIAR SPECTRA.—In a communication to *Astronomische Nachrichten*, No. 3070, Prof. Pickering records that the three stars tabulated below show bright lines in their photographic spectra, and belong to the same class as the stars discovered by Wolf and Rayet:—

Designation.	R.A. 1900.		Decl.	Galactic latitude.	Galactic longitude.
	h. m.	s.			
D.M. + 55°2721 ...	22 15	0 ...	55 37 ...	0 50 ...	70 29
—	22 23	7 ...	55 46 ...	- 1 20 ...	71 38
D.M. + 56°2818 ...	22 32	9 ...	56 23 ...	- 1 25 ...	73 3

It will be seen that these stars, like the 35 others of the same class, fall near the central line of the Milky Way.

THE TOWER OF BABEL AND THE CONFUSION OF TONGUES.<sup>1</sup>

WHO among the readers of ancient history has not pictured to himself great Babylon, with its long straight streets at right angles, its quays along the banks of the Euphrates, its royal palaces, its double walls, and last, not least, its towers in stages, dedicated to the various gods? The picture of grandeur is one of which we can form an estimate only, but it must have been magnificent beyond what was customary in those days, for had not the great Nebuchadnezzar built it? He describes at great length what he had done for the city, for its walls, for its streets, its temples, its towers, and its palaces.

But there was a time when Babylon was not the great city. At first a village settlement, it gradually arose to be the capital of a powerful State, a progress that probably occupied 4000 years, not including the pre-historical period. The story of the beginnings of this great city, which are lost in antiquity, is told in Genesis, and forms one of the most charming of the legends of the Bible. The Biblical account is given in the genealogical table just before "the generations of Shem," and seems to be an interpolation to explain the numerous languages of the world. What the source of the legend may be is uncertain, but as a whole it is unique, for though its source is possibly Babylonian, nothing like it has yet come from that country or from Assyria. The so-called Babylonian legend of the Tower of Babel seems to have nothing to do with the Biblical one—indeed, the evidence all points to its referring to something entirely different.

"As they journeyed (so the Bible narrative says) in the East, they found a plain in the land of Shinar." This land of Shinar is generally regarded as the Sumer of the Babylonian and Assyrian inscriptions. The Sumerians and Akkadians were of a different stock from the Semitic inhabitants of the country, and

<sup>1</sup> Abstract of a Lecture by Theo. G. Pinches, before the London Institution, December 3, 1891.

spoke two entirely different dialects, making, with the Kassite, the Semitic Babylonian, the Aramaic, and the Chaldee, no less than six dialects and languages; and, as if this Babel were not enough, the tones of Elauites and other foreigners might also be heard. It will probably be admitted that the confusion of tongues which this gathering of nations made at Babylon was striking enough to the visitor in whose native land one language only prevailed.

The indications point to the fact that the Akkadians were the invaders in Babylonia, and they gave a great many kings to the land. It was a state of things not unlike the heptarchy in Old England—a number of small States fighting amongst themselves, the most powerful gradually absorbing the weaker, until, about the time of the great Hammu-rah, about 2220 B.C., the whole became united; after which date probably only the wild Chaldean tribes remained practically independent, under their native chiefs, and afterwards gave kings to Babylonia itself.

The Semitic Babylonians of Mesopotamia were probably rather short and thick-set, though there must have been a great many people of normal height and even tall stature among them. They were dark and heavily bearded, but during the time of the Akkadian supremacy they seem to have shaved, like their rulers. The Akkadians seem to have had noble and dignified features, and their figures, as shown on the engraved and sculptured stones, were far from inelegant. There was also, apparently, a type of Akkadian with a curved prominent nose and a retreating forehead, something like the Elamites shown on the Assyrian bas-reliefs. [Several examples of the various types were shown.]

These people, journeying "in the East," resolved to build a city "and a tower"; and this tower, which the inhabitants of Shinar decided to build, was quite a special thing of their own. Every city in ancient Babylonia had a tower, some more than one, and they were of varying forms. The Semitic Babylonians seem to have called their memorial towers *zikkurāti*, a name which was even applied (as in the Babylonian account of the Flood) to natural eminences of a similar form. The Akkadians appear to have called them "watch-towers." They were intended (according to Perrot and Chipiez) to give that picturesque element to the land which accidents of Nature usually give to other countries more favoured, and also to astonish the contemporary traveller, as well as that posterity for whom no more than a heap of shapeless ruins would remain. However that may be, they certainly served in their time a practical purpose—namely, for religious ceremonies, and for astrological and astronomical observations. There were twenty-two principal erections of this kind in the earliest period in Babylonia, according to one of the lists.

Descriptions and illustrations were now given of the different forms of towers in Babylonia, and it was pointed out that Nebuchadnezzar mentioned a "Tower of Babel" (*zikurat Babilam*) which he "made anew," and "raised its head with burnt brick and bright lapis"; but he did not devote many words to it—why, is not known, unless it be that some ill omen was attached to it. This "Tower of Babel" of Nebuchadnezzar is not the Birs-Nimroud, and for that reason, as well as because the latter did not lie within Babylon, we may doubt whether it be the Biblical "Tower of Babel," as has been, and still is, supposed.

It is difficult now to imagine the place where the great confusion of tongues existed as the site of a great city, with its teeming life. The place where Babylon stood is now a series of mounds more or less shapeless, and masses of brickwork, but otherwise a marsh. The "great city," "the beauty of the Chaldees' excellency," has "become heaps." The ruins of the palace of Nebuchadnezzar, and of the temple-tower of Babil, are among the more prominent remains.

After a sketch of the life of the city of Babylon in ancient times and the religious festivals and ceremonies, and how the temple-towers and the services remained after the cities had decayed and practically vanished, the lecturer recited a translation of the hymn to the setting sun sung by the priests of Ê-zida, the supposed Tower of Babel—

*Hymn to the Setting Sun, chanted by the Priests of Ê-zida.*

"Sun-god, in the midst of heaven,  
At thy setting,  
May the larch of the glorious heavens  
Speak thee peace;  
May heaven's door to thee be gracious;  
May the Director, thy beloved messenger, direct thee.

At Ê-bàra, the seat of thy lordship,  
Show forth thy supremacy.  
May Aa, thy beloved wife,  
Gladly go to meet thee.  
May thy heart take rest,  
May the property of thy godhood  
Be confirmed to thee.  
Warrior, hero, Sun-god, may they glorify thee!  
Lord of Ê-bàra, may the road of thy path be prosperous—  
Sun-god, cause thy highway to prosper,  
Gong the everlasting road to thy rest.  
Sun-god, thou art he who is the judge of the land,  
Causing her decisions to be prosperous."

The priests' morning hymn began:—

"Sun-god, in the glorious heavens rising,"

and the lecturer pictured the day when the priests who chanted these hymns were there no more, and the faith which had raised Babylon's splendid temples and noble towers was, at last, as dead as her departed glories, to become the heritage of the student and of those who love to hear the ever-charming story of the romanceful East.

### A YEAR'S SCIENTIFIC WORK IN NEW GUINEA.

A RECENT administration report from New Guinea, issued by the Colonial Office, contains an appendix on the scientific work of the year in the island. The first paper in this is a report by Baron von Mueller on the botanical specimens collected. He says that the increase in our knowledge of the Papuan flora, derived from Sir William MacGregor's collection in 1890, has been again important. Foremost as a result we learn from these contributions that a considerable number of Australian species of plants, which, as such, were hitherto regarded as quite endemic, are likewise indigenous to the vicinity of the Mai-Kussa and Wasi-Kussa in New Guinea. Thus they occur precisely opposite to Cape York, from whence the seeds may have been carried across by migratory birds or perhaps by some other agencies. These, otherwise only Australian, plants may therefore not really belong to the primitive vegetation of New Guinea, though they are now established in such a way as not to admit of distinguishing them in regard to their origin from the great bulk of the lowland species, whether truly Papuan or simultaneously also Malayan. The occurrence has already been demonstrated of a number of lowland plants of specific Australian type in various parts of New Guinea. To these can now be added a number of others which are specified by Baron von Mueller. It can now be shown also that the cedar (or rather cedrel), of which many shipments have been made to Australian ports, is identical with the Singapore cedar (*Cedrela Toona*). The magnificent and renowned aquatic plant, *Nelumbo nucifera*, has now been located on the upper Fly River. Some other plants, unknown from New Guinea before, such as *Polygala chinensis*, *Salomonina oblongifolia*, *Sesuvium Portulacastrum*, *Leptospermum Javanicum*, and *Limnophila gratioleoides*, are recorded in the Administrator's last collection, while some more are awaiting careful comparative elucidation before the fixing of their systematic position. Count Solms-Laubach, the monographer of Pandanæa, has acknowledged the screw pine from Ferguson Island, in the Louisiades, as a new species under the name *P. Macgregorii*. An essay of Baron von Mueller on the highland plants collected during the year by Sir William MacGregor has appeared in the publications of the Royal Society of Victoria. But he was able to examine only a few of the ferns brought from the upper region of the Owen Stanley Range; among them, however, is the new *Cyathea Macgregorii*, which reaches a higher elevation than any other of the many kinds of fern-trees now known. To expedite the determination of their specific position, Mr. Baker, of Kew, has undertaken to define systematically the seventy species of *Ficulis* and *Lycopodiaceæ*, contained in Sir William MacGregor's collection from the Owen Stanley Ranges. Mr. Baker regards nineteen of these ferns as new, and therefore, so far as our present experience reaches, as exclusively Papuan. These hitherto unknown species are comprised within the genera *Cyathea*, *Hymenophyllum*, *Dicksonia*, *Davallia*, *Lindsaya*, *Aspidium*, and largely *Folypodium*. The Curator of the Queensland Museum reports on the zoological collections. No new animal of the warm-blooded class has been met with during the year;

perhaps those remaining to be found in the coast country are both few and rare. By way of compensation, however, certain Australian birds, the native companion, white ibis, and royal spoonbill, must now be included in the Papuan avifauna as at least temporary sojourners on the banks of the Fly River. It is noteworthy that these birds were found on the Fly River during the continuance in the north of Queensland of a drought which had driven them from their haunts proper and scattered them far and wide in search of water. Of the reptiles, on the other hand, a few new forms are distinguishable. These occur among the lizards. Two handsome snakes, *Chondropython acurus* and *pulcher*, have been added to the State collection of Papuan ophidians. On the whole, the vertebrate collection is subordinate in importance and interest to that of the insect division of the invertebrates. The whole of the insects collected were examined by the Entomological Department, and two reports on the *Lepidoptera* and *Coloptera* are appended. From these it appears that several species both of butterflies and beetles are new to science. The collection contains in many instances a large series of examples of the same insect, which is all-important in the case of variable forms, whose unknown range of variation is a prolific source of error. Besides *Lepidoptera* and *Coloptera* it contains many Hemipterous insects which have not yet been determined. The few forms of Mollusca procured on the Fly River have yielded but one new species, a remarkably fine *Nanina*.

#### A MEDIUM FOR PRESERVING THE COLOURS OF FISH AND OTHER ANIMALS.

OUR readers may remember that Mr. Haly, Curator of the Colombo Museum, has for some years been making experiments so as to discover a medium which will preserve the colours of fish and other animals. We quote the following from the last Annual Report of the Colombo Museum:—

"In my last year's report I made some remarks on the use of carbolized oil as a mounting fluid for specimens already prepared by other means, the idea that it was a preservative in itself not having occurred to me. Further experiments this year seem to show (I do not like to speak too confidently in a climate like this, even with twelve months' experience) that it is one of the most perfect preservatives known both for form and colour.

"Coco-nut oil and carbolic acid freely mix in all proportions. The mixtures at present under trial are oil raised to the specific gravity of 10° and 20° below proof-spirit by the addition of acid. Whilst the gum and glycerine process is absolutely useless for any animals except certain families of fish, this mixture is good for every kind of vertebrate. The most delicate frogs are quite uninjured by it, and snakes undergo no change. The delicate plum-like bloom on the geckoes, the fugitive reddish tint on such snakes as *Ablabes humberti*, are beautifully preserved by it.

"Another most important use is in the preservation of large fish skins, which can be packed away in it for an indefinite period, and mounted when wanted. These skins do not require varnishing, neither do they turn brown, but although, of course, they do not preserve their sheen like fish in the oil itself, they always maintain a silvery and natural appearance, quite different from that of ordinary museum specimens. If ever we get a new fish gallery, a show of our large species prepared in this way would form a most effective exhibition.

"It appears also to be a most excellent preservative for Crustacea and the higher orders of Arachnids, and also for Centipedes, but it has hitherto proved a failure for marine invertebrates in general. It must be remembered, however, that the perfect miscibility of the two liquids opens up endless possibilities. Its absolutely unevaporable nature makes it invaluable in a tropical climate, quite apart from its other qualities.

"With regard to this last remark I take the opportunity of stating that the acid enables coco-nut oil and turpentine to be mixed together. This forms a splendid microscopic fluid, in which objects may be allowed to soak without any previous preparation, and in which they become very transparent. A minute species of Crustacean, of the order Copepoda, and the leg of a fly, simply laid on a slide in a drop of this fluid and covered with an ordinary covering-glass, without any cell being made or cement employed, have lain on my table unaltered for the last ten months, and I cannot help thinking that such a medium as this cannot fail to prove a great boon to all workers with the microscope."

NO. 1157, VOL. 45]

#### SCIENTIFIC SERIALS.

*American Journal of Science*, December.—On Percival's paper of the Jura-Trias trap-belts of Central Connecticut, with observations on the up-turning, or mountain-making disturbance, of the formation, by James D. Dana.—The detection and determination of potassium spectroscopically, by F. A. Gooch and T. S. Hart. By dipping platinum coils of different sizes in a solution of the salt to be tested it was found possible to take up known quantities of material for introduction into the volatilizing flame employed. Experimenting in this manner with a single-prism spectroscope, it was found that  $\frac{1}{100}$  of a milligram of potassium produced a line distinctly visible with a slit of 0.18 mm., and  $\frac{1}{1000}$  mgr. with a slit of 0.23 mm. The test appears to be less delicate with potassium sulphate than when the chloride is used, and rather more delicate in the case of the carbonate. The red line of potassium was unmistakably seen when only  $\frac{1}{20000}$  mgr. of potassium was introduced into the flame in the form of the carbonate. For quantitative determinations a standard solution, from which  $\frac{1}{100}$  mgr. of potassium was taken by a certain platinum coil, was employed. The *modus operandi* was to dilute the test-solution until the line given by the potassium contained in a coil-full was of the same brightness as that given by the same quantity of the standard solution. Remarkably consistent results were thus obtained. An interesting point brought out by the experiments is that the presence of sodium salts in the flame is of direct influence in strengthening the spectrum of potassium.—The ultra-violet spectrum of the solar prominences, by George E. Hale. This important paper was read at the last meeting of the British Association, and has been previously noted.—Phonics of auditoriums, by Ephraim Cutter. It is generally known that a well-constructed auditorium resonates certain sounds better than others, and that many clergymen accommodate their tone of speaking to the key-note of their church. Dr. Cutter has made observations on this point in four halls, and recommends those who control auditoriums to find the key-note and post up the result. Thus, an auditorium at Saratoga Springs was tested in 1890, and a notice was put up, "The key-note of this hall is F."—The secular variation of latitude, by George C. Comstock. This is a general account of the observations made at Greenwich, Pulkova, Madison, and elsewhere, which indicate that the latitude of a single place is subject to a secular variation.—On the capture of comets by planets, especially their capture by Jupiter, by H. A. Newton.—Distribution of titanic oxide upon the surface of the earth, by F. P. Dunnington. An estimation has been made of the titanium in eighty different specimens of soil taken from different parts of the earth's surface. Soils from Virginia gave an average of 1.57 per cent. of titanic oxide, and twenty-two samples from other portions of the United States gave an average of 0.85 per cent. The average proportion in air-dried soils from Oceania and Asia (14 specimens) was 0.90 per cent., and 16 specimens from Europe gave 0.54 per cent. The eight remaining estimations were made on typical rocks of the localities which furnished the samples for analysis.—Notes on a Missouri barite, by C. Luedeking and H. A. Wheeler.—The contraction of molten rock, by C. Barus. A sample of diabase has been fused and allowed to cool slowly. The molten rock contracted regularly until a temperature of 1093° was reached, when the diabase solidified with a sudden contraction of bulk. The density of the original rock was 3.0178, and that of the glass obtained 2.717. The observations indicate that "structural rock texture is due to pressure, i.e. pressure induces a redistribution of molecules, such that the smallest specific volume possible under the given conditions may result."—Notes on Michigan minerals, by A. C. Lane, H. F. Keller, and F. F. Sharpless. The minerals considered are chloritoid, grünerite, and riebeckite.

#### SOCIETIES AND ACADEMIES.

LONDON.

Royal Society, December 10.—"On a Compensated Air-thermometer." By H. L. Callendar, M.A.

The air-thermometer is the ultimate standard to which all measurements of temperature have to be referred. It therefore becomes a question of considerable importance to determine

what form of instrument is capable of giving the most accurate results.

For practical purposes there can be no doubt that electrical resistance thermometers, which are much easier to read and manipulate, and which are, at the same time, exceedingly constant over a very wide range, would be much more convenient as standard instruments. But for theoretical work it is always necessary to reduce their indications to the scale of absolute temperature.

With this object the writer has been for some years engaged in endeavouring to construct an air-thermometer which should be capable of reading to a degree of accuracy comparable with that attained by the use of electrical-resistance thermometers. This he believes that he has at length succeeded in securing by the adoption of the modified and compensated form of differential air-thermometer described in the paper.

The common and familiar form of differential air-thermometer consists essentially of two equal bulbs, communicating with opposite limbs of a U-tube of small bore containing sulphuric acid, which serves to indicate the difference of pressure between them. If the standard bulb be kept in melting ice, so that its temperature is constant, it is possible, by using a kathetometer microscope, to read small changes of temperature in the thermometric bulb with an accuracy of the order of a thousandth of a degree.

In order to make the instrument capable of reading over a wider range, it is only necessary to add an auxiliary bulb, as in the ordinary "constant-pressure" type of air-thermometer, into which the air from the thermometric bulb is allowed to dilate. The auxiliary bulb is provided with taps, through which mercury can be introduced or withdrawn in weighed quantities, to equalize the pressures. The dilatation of the air at constant pressure can be very accurately measured by weighing the mercury displaced. This form of air-thermometer has the advantage of being entirely independent of barometric readings. A great deal of trouble is thus saved; moreover, it is certain that a much greater degree of accuracy can be attained in this way in the measurement of a volume than in the measurement of a pressure by means of a mercury manometer, as in the "constant-volume" type of air-thermometer.

With almost every form of air-thermometer, some part of the air contained in the connecting tubes is necessarily exposed to temperatures different from those of the bulbs. In accurate work a correction must always be applied for this by calibrating the connecting tubes and estimating their mean temperature. This correction, however, is exceedingly troublesome to apply, and becomes a very serious source of uncertainty in attempting to work to a thousandth of a degree.

It is, perhaps, the greatest advantage of this particular form of differential air-thermometer, that this troublesome and uncertain correction can be completely eliminated both from the observations and from the calculations by simply duplicating the connecting tubes—that is, by making the thermometric and standard bulbs communicate with similar sets of connecting tubes fixed side by side in such a way that their mean temperatures are always equal. Provided that the two bulbs contain equal masses of air, and that their pressures are adjusted to equality, any change in the temperature of the connecting tubes will affect both equally, and will not, therefore, alter the reading of the pressure-gauge.<sup>1</sup> In this way not only is the work of taking and reducing the observations immensely simplified, but the results are also rendered much more accurate.

The form of instrument above described is designed for the most accurate work. For rough purposes, and especially for limited ranges of temperature, for which the auxiliary bulb can be dispensed with, much simpler instruments may be constructed and compensated on similar principles.

In ordinary work it would be inconvenient to have to keep the standard bulb always at a constant temperature. The necessity for this may, however, be avoided by adjusting the quantity of sulphuric acid in the pressure gauge so that its expansion compensates for the increase of pressure in the standard bulb due to rise of temperature of the surrounding air. When the instrument is thus compensated, one of the tubes of the pressure gauge can be directly graduated in degrees of temperature. The indications are then as easy to read as those of a mercury thermometer. Such thermometers are very convenient for rough work at temperatures beyond the range of mercury

thermometers. They can be made with a range from 300°–500° C.<sup>1</sup> (500°–900° F.), and will read to a tenth of a degree at 450° C. They are practically free from change of zero, and if properly compensated their indications are very reliable. Since the connecting tubes are compensated, they can be made of considerable length, and even of flexible material, such as copper tubing, without much loss of accuracy. This is often a matter of great convenience, especially in high temperature work.

"Repulsion and Rotation produced by Alternating Electric Currents." By G. T. Walker, B.A., B.Sc., Fellow of Trinity College, Cambridge. Communicated by Prof. J. J. Thomson.

The author described the following experiment:—A sheet of copper is placed so as to half cover an alternating magnetic pole. Upon this, near the pole, is laid a hollow sphere of copper. The electro-magnetic action produces a couple so powerful that the friction of rotation is overcome, and the sphere spun round.

In order to throw light on this, after a theorem in § 2 as to the kind of currents set up in a conductor, I have considered a number of cases. A thin circular infinite cylindrical shell lies in an alternating field of currents parallel to its axis, and the couple upon it is found. The result is applied to give the couples on two such shells in the presence of a parallel current and of a pair of currents forming an electro-magnet.

The couple in action upon a thin spherical shell in a general periodic field has next been found, and is applied to give the couples on two thin shells under the influence of—

- (i.) An alternating current in a straight infinite wire.
- (ii.) A pair of such currents forming an electro-magnet.
- (iii.) An alternating magnetic pole.
- (iv.) An alternating electro-magnet of very short length.

Chemical Society, November 19.—Sir Henry Roscoe, F.R.S., in the chair.—The following paper was read:—Iron carbonyl, by L. Mond, F.R.S., and Dr. Langer. An account of this paper has already appeared in NATURE of November 26 (p. 89).—A lecture was then delivered on colour photometry, by Captain Abney, C.B., F.R.S. According to the lecturer, the colour of a body, when viewed in a light of standard quality, is known when (a) its luminosity, (b) its hue, and (c) its purity, or the extent to which it is freed from admixture with white light, are known and expressed by numbers. The luminosity of a colour can be given in absolute number by referring it to the standard of white. The standard of white employed is a surface coated with zinc oxide. It is also necessary to employ a standard light in these experiments, and the light recommended is that from the crater of the positive pole of the electric light, or from a petroleum lamp, when the illumination need not be so intense. The luminosity of the pure spectrum colours may be measured by what the author calls the colour patch apparatus, which is described in the Phil. Trans., 1886, and in his book on "Colour Measurement and Mixture." The luminosity of a colour is not the same when viewed from all parts of the eye. The luminosity of any pigment on paper can be found by rotating it with two or three colours, red, emerald-green, and ultramarine. The colour of a pigment can be referred to the spectrum colours by measuring the absorption. The mixture, in varying proportions, of red, green, and violet of the spectrum, makes white. Any other colour can be matched by the mixture of the same three colours. Since three colours will make white, and the same three colours will make a match with an impure colour, every colour in nature can evidently be matched by mixing not more than two of these colours with a certain proportion of white light, and if these colours be red and green, or green and violet, the colour can be matched by one spectrum colour and white light, since there is some intermediate colour which has the same hue as the mixture of these two colours. Hence any colour may be expressed in terms of white light and one spectrum colour, the latter in wave-lengths and the former in percentage of luminosity. The lecturer performed experiments in illustration of all the points brought forward. The importance of using some uniform light was insisted upon throughout. In conclusion the lecturer claims to have demonstrated that the reference of colours to numbers is not only possible but easy.

December 3.—Prof. A. Crum Brown, F.R.S., in the chair.—The following papers were read:—Phosphorous oxide, Part II.,

<sup>1</sup> An air-pyrometer and also a long-distance thermometer of this pattern are made by Mr. J. J. Hicks, of Hatton Garden, E. C.

<sup>1</sup> The equations and conditions of compensation are fully given in the paper.

by T. E. Thorpe, F.R.S., and A. E. Tutton. In this paper the authors have continued their description of the properties of phosphorous oxide,  $P_2O_5$ . In their first paper they state that phosphorous oxide becomes red on exposure to light. They have now obtained the oxide in large crystals, unaffected by light, by exposing the freshly-distilled oxide to sunshine for several months at a time, and decanting the melted oxide from the red phosphorus produced. Large crystals of the oxide are also obtained by sublimation in a vacuum, and these are unaffected by light so long as they retain their crystalline form. The authors also describe the reactions of the oxide with the following substances: bromine, iodine, hydrogen chloride, sulphur, sulphur trioxide, sulphuric acid, sulphur chloride, ammonia gas, nitrogen peroxide, phosphorus pentachloride, and phosphorus trichloride. The following substances are apparently without action on phosphorous oxide: hydrogen, phosphoretted hydrogen, carbon monoxide, carbon dioxide, sulphur dioxide, nitrogen, nitric acid, cyanogen, and ethylene.—Frangulin, Part ii., by T. E. Thorpe, F.R.S., and Dr. A. K. Miller. The authors have prepared frangulin more nearly in a state of purity than was previously possible. They find that crude frangulin contains a substance isomeric with emodin, which clings to it persistently, and is very difficult to remove. They have succeeded in proving the correctness of Schwabe's formula,  $C_{21}H_{20}O_9$ , for frangulin. On hydrolysis it yields emodin,  $C_{15}H_{10}O_5$ , and rhamnose,  $C_6H_{12}O_5$ , according to the equation  $C_{21}H_{20}O_9 + H_2O = C_{15}H_{10}O_5 + C_6H_{12}O_5$ .—The structure and chemistry of flames, by A. Smithells and H. Ingle. The authors have been engaged for twelve months in investigating the chemistry of flames produced by burning known hydrocarbons, and are still continuing the experiments. If a long glass tube be fitted over the metal tube of a Bunsen burner so as to form a wider continuation of it, and if the gas be carefully regulated, it is possible to divide the flame into two cones, one of which remains at the top of the tube, and the other oscillates inside the tube. By heating the glass tube at one point so as to increase at that point the rate of inflammation, it is possible to fix the oscillating inner cone—that is, to prevent its re-ascend. The same result is obtained by narrowing the bore of the glass tube at one point, so as to diminish the rate of inflammation, *i.e.* to prevent the descent of the inner cone past that point. In this way the two cones can be kept any distance apart for any length of time. This permits of the aspiration of the gases from the space between the cones without any chance of admixture of outside air or of products of combustion from the upper cone. The apparatus used by the authors is described. The flames of liquid hydrocarbons were examined by charging air with the vapour of the liquid, and afterwards mixing this vapour-charged air with more air in suitable proportions. The hydrocarbons examined were ethylene, methane, pentane, heptane, and benzene. The results obtained show that the products of combustion of the first cone are essentially  $CO_2$ ,  $H_2O$ ,  $CO$  and  $H_2$ , and that the second cone is due to the combustion of the  $CO$  and  $H_2$  with the external air. These results are in harmony with the conclusions of Blochmann, and with the work of Dalton on the explosion of methane and ethylene with oxygen in quantities insufficient for complete combustion. The authors point out: (1) that, even in excess of oxygen, carbon turns preferentially to  $CO$  and not to  $CO_2$ ; (2) that the heat of combustion of gaseous carbon to  $CO$  is probably greater than that of hydrogen to  $H_2O$ ; (3) that, according to Dalton,  $CH_4$ , when burnt with its own volume of oxygen, gives products represented in the equation  $CH_4 + O_2 = CO + H_2O + H_2$ . But as the two substances,  $CO$  and  $H_2O$ , act upon one another,  $CO + H_2O \rightleftharpoons CO_2 + H_2$ , the case is one of reversible change, and four products will result—*viz.*  $CO_2$ ,  $H_2O$ ,  $CO$ , and  $H_2$ . They have succeeded in dividing into two cones the flame produced by admixture of air with cyanogen; the products of the inner cone were found to consist of 2 vols. of  $CO$  and 1 vol. of  $CO_2$ .—Note on the structure of luminous flames, by A. Smithells. A brief summary of the various views that have been held on this subject is given. The author would describe a luminous flame as follows: (1) an outer sheath or mantle, with (2) an inner, bright blue portion, visible at the base of the flame—these two parts correspond respectively to the outer and inner flame cones of a Bunsen flame, and mark the region where the coal gas or candle gas is burning with a large quantity of air; (3) the yellow luminous part, where the heat of the parts (1) and (2) is decomposing hydrocarbons, setting free carbon which rapidly glows and

burns; (4) the dark inner region, consisting of unburned gas.—The existence of the mydatic alkaloid hyoscyamine in lettuce, by T. S. Dymond. The alkaloid was obtained from the commercial extract of wild lettuce, of the edible plant known as cos lettuce, and from a specimen of the dried flowering plant of wild lettuce. It was found to have approximately the same melting-point and other properties as hyoscyamine, the poisonous mydatic alkaloid existing in belladonna, henbane, and other plants belonging to the natural order *Solanaceae*. The aurichroid melted at  $159^{\circ}75$ , and on analysis gave results corresponding to the formula  $C_{17}H_{23}NO_3$ .  $H AuCl_4$ .—Cryptopine, by D. Rainy Brown and Dr. W. H. Perkin, Jun., F.R.S. The authors have commenced an investigation on the rare alkaloid cryptopine, which occurs in small quantity in opium. Analyses of the base and of the oxalate confirm the results of Hesse, and show that cryptopine has the formula  $C_{21}H_{23}NO_5$ . On oxidation with permanganate it yields, among other products, metahemipinic acid (m.p.  $179^{\circ}$ – $180^{\circ}$ ). It contains only two methoxy-groups, as shown by its behaviour with hydriodic acid, these two groups being situated in that part of the molecule which is converted to metahemipinic acid on oxidation.—The action of sodium on ethereal salts, Part iii. benzylic orthotoluate, by R. W. Hodgkinson. When benzylic orthotoluate is heated to  $200^{\circ}$  and sodium dissolved in it, the temperature rises to  $250^{\circ}$ , when an oil distils over. This oil was separated into toluene, benzoyl alcohol, and a small quantity of the original salt. The sodium salt in the retort gave pure orthotoluate, unchanged benzylic orthotoluate, and a substance of the composition  $C_{10}H_{10}O_2$ . The author is continuing the experiments.—The gas-volumeter and gravimometer, by G. Lunge. A reply to Prof. Japp's reply to the author's criticisms (*Ber. xxiv.* 1656).—The action of sulphuric acid on the bromides of hydrogen, potassium, and sodium, by F. T. Addyman. The author has sought to determine the extent to which hydrogen bromide is oxidized by sulphuric acid under varying conditions of mass and dilution.—The iodometric estimation of chlorine, by Dr. G. McGowan. Finkener has stated that Bunsen's method when applied to chlorates gives less than the theoretical amount of chlorine. The author describes experiments which prove the accuracy of Bunsen's method, and suggests that Finkener's error arose from a slight loss of chlorine.

**Mathematical Society, December 10.**—Prof. Greenhill, F.R.S., President, in the chair.—The President announced the recent decease of Prof. Wolstenholme, with whom he had been associated at Cooper's Hill, and paid a feeling tribute to his memory, in the course of which he touched upon Prof. Wolstenholme's mathematical work.—The following communications were made:—The equations of propagation of disturbances in gyrostatically loaded media, by J. Larmor. In the first instance an extended body is imagined, in Sir W. Thomson's manner, as built up of rigid solid elements, each containing a cavity in which is mounted a rapidly rotating fly-wheel; and this structure is then pushed to the limit when it gives a continuous elastic medium. Such a medium possesses at each point two coefficients of inertia—a scalar one which is specified as the density, or mass per unit volume, and a vector one which measures the angular momentum per unit volume. As we can thus imagine a solid with two persistent constants of inertia, and as it is apparently not possible to have more than these two, it seems worth while to formally express the general equations of elasticity that will apply to such a body. It turns out that, for a homogeneous body having (LMN) as its vector constant of inertia, there must be added to the force per unit volume due to the tractions of the surrounding parts a term of which the  $x$  component is

$$-\frac{1}{2} \left( L \frac{d}{dx} + M \frac{d}{dy} + N \frac{d}{dz} \right) \frac{d}{dt} \left( \frac{dv}{dx} - \frac{dw}{dy} \right),$$

( $uvw$ ) being the displacement. The waves of permanent type in such a medium, otherwise isotropic, are all circularly polarized, the coefficient of rotation being simply proportional to the component of the rotary inertia in the direction of propagation. If the rotary apparatus is more complex than a simple fly-wheel, so as to have free periods of its own, these will be indicated by anomalous rotatory dispersion, and the equations will require modification. It is pointed out that of the three terms put forward by Sir G. Airy as competent to explain the magnetic rotation of light, the one verified by Verdet enters simply in the above manner; while the others, which do not by themselves agree with experiment, imply absolute time-constants, such as



free periods of molecular vibration, associated with the rotational property.—On the theory of elastic wires, by A. B. Basset, F. R. S. The stresses which act across any section of a thin elastic wire consist of a tension along the tangent, two shearing stresses along the principal normal and binormal respectively, and three couples about these directions. By resolving parallel to these directions, and taking moments about them, six equations can be obtained, which determine the stresses, when the unstrained form of the wire is given. The values of the three couples can be obtained by a method similar to that employed in my papers on thin elastic plates and shells; and when the wire is inextensible, these values lead to four equations connecting the displacements of any point on the axis, together with a quantity  $B$ , such that  $dB/ds$  measures the twist per unit of length. The torsional vibrations of a complete circular wire are afterwards investigated; and it is shown that they consist of a long period and a short period; and that the gravest note is due to the torsional vibrations, and its frequency is proportional to the square root of  $18\pi g^2/\rho a^4(8n + g)$ , where  $a$  and  $c$  are the radii of the axis and cross-section respectively,  $\rho$  the density,  $n$  the rigidity, and  $g$  is Young's modulus.—Researches in the calculus of variations; ii., discrimination of maxima and minima solutions when the variables are connected by algebraical equations, the limits being supposed fixed, by E. P. Culverwell.—Note on the algebraic theory of elliptic transformation, by J. Griffiths.—Messrs. A. B. Kempe and J. Hammond made short impromptu communications, and also took part with Messrs. Larmor, Basset, Forsyth, Love, S. Roberts, and the President, in the discussions on the papers.

**Royal Meteorological Society, December 16.**—Mr. Baldwin Latham, President, in the chair.—Mr. W. Marriott gave the results of the investigation undertaken by the Society into the thunderstorms of 1888 and 1889, which he illustrated by a number of lantern slides. The investigation was originally confined to the south-east of England, but as this district was found to be too circumscribed, it became necessary to include the whole of England and Wales. After describing the arrangements for collecting the observations, and the methods adopted for their discussion, Mr. Marriott gave statistics showing the number of days on which thunderstorms occurred at each station; the number of days of thunderstorms in each month for the whole country; the number of days on which it was reported that damage or accidents from lightning occurred; and also the number of days on which hail accompanied the thunderstorms. In 1888 there were 113 days, and in 1889 123 days on which thunderstorms occurred in some part of the country. The number of days with damage by lightning was 33 in 1888, and 38 in 1889; and there were 56 days in each year on which hail accompanied the thunderstorms. The tables of hourly frequency show that thunderstorms are most frequent between noon and 4 p.m., and least frequent between 1 a.m. and 7 a.m. Thunderstorms appear to travel at an average rate of about 18 miles per hour in ill-defined low barometric pressure systems, but at a higher rate in squally conditions. The author is of opinion that individual thunderstorms do not travel more than about 20 miles; and that they take the path of least resistance, and are consequently most frequent on flat and low ground. Detailed isobaric charts, with isobars for two-hundredths of an inch, were prepared for 9 a.m. and 9 p.m. each day for the month of June 1888. An examination of these charts showed that, instead of the pressure being so very ill-defined as appeared on the daily weather charts, there are frequently a number of small but distinct areas of low pressure, or cyclones, with regular wind circulation; and that these small cyclones passed over the districts from which thunderstorms were reported. Sometimes it is not possible to make out well-formed areas of low pressure from two-hundredths of an inch isobars, but there is a deflection of the wind which shows that there is some disturbing cause; and thunderstorms have usually occurred in that immediate neighbourhood. The author believes that the thunderstorm formations are small atmospheric whirls—in all respects like ordinary cyclones; and that the whirl may vary from 1 mile to 10 miles or more in diameter. There are frequently several whirls near together, or following one another along the same track. The numerous oscillations in the barometric curve are evidently due to the passage of a succession of atmospheric whirls; and it appears that lightning strokes are most frequent when these oscillations are numerous.—Mr. F. J. Brodie read a paper on the prevalence of fog in London during the twenty years 1871 to 1890. The popular notion that November is *par excellence* a

month of fog is not confirmed by the figures given by the author. The number of fogs in that month is, if anything, slightly less than in October or January, and decidedly less than in December, the last-mentioned month being certainly the worst of the whole year. The latter part of the winter is not only less foggy than the earlier part, but is clearer than the autumn months. In February the average number of days with fog is only 6.6, as against 8.9 in January, 10.2 in December, 9.2 in October, and 8.8 in November.

**Linnean Society, December 17.**—Prof. Stewart, President, in the chair.—Mr. G. C. Druce exhibited specimens of *Sagina maritima*, Don MS., var. *alpina*, Syme, gathered on steep rocky places on the Cairngorms, and of *Illecebrum verticillatum*, Linn., found near Wellington College, Berks.—Dr. R. C. A. Prior exhibited some fruits of the baobab (*Adansonia*), and an undetermined species of palm, which had been sent from Matabele Land as good to eat, under the misleading names of "cream of tartar fruit" and "wild orange." He read an extract from Oates's "Matabele Land," describing the natural growth and appearance of the baobab as observed in that country.—The Hon. W. B. Espeut exhibited some nests of humming-birds from Jamaica, and pointed out the variety of materials used by the same species, though placed in the same tree (a mangrove), the coloration in some cases being protective, in others not.—A paper was then read on the occurrence of two species of Crustacea belonging to the sub-order *Cumacea* in New Zealand, whence none had been previously described. The author gave the result of his dredging in the Bay of Islands in the north, and in the inlets of Stewart Island in the south, and furnished drawings and descriptions of the species referred to.—A paper on the development of the head of the imago of Chironomus, by Prof. L. C. Miall and A. R. Hammond, was read by Mr. Hammond, accompanied by a series of illustrations with the oxyhydrogen lantern. The subject was introduced by a brief sketch of the life-history of the insect in its three stages, followed by detailed descriptions of the head both of the larva and of the imago. The history of the epidermic invaginations, by which the imaginal head is formed within the larval head and prothorax, was then followed out to its consummation in the development of the fly. The lantern arrangements were successfully carried out by Mr. Frederick Enock.

#### PARIS.

**Academy of Sciences, December 21.**—M. Duchartre in the chair.—List of prizes awarded to successful competitors in 1891:—*Geometry*.—Prix Francœur, M. Mouchot; Prix Poncelet, M. Humbert. *Mechanics*.—Extraordinary Prize of 6000 francs: this was divided into four, two principal prizes of equal amount to MM. Pollard and Dubeod, one to M. Guyon, and the fourth to M. Chabaud-Arnaud. Prix Montyon, M. Caméré. Prix Plumey, M. de Maupeou. Prix Dalmont, M. Considère; MM. Autonne and Ocagne being given honourable mention. *Astronomy*.—Prix Lalande, M. G. Bigourdan. Prix Damoiseau (not awarded). Prix Valz, Prof. Vogel. Prix Janssen, M. G. Rayet. *Physics*.—Prix La Caze, M. J. Violle. *Statistics*.—Prix Montyon, MM. Cheysson and Toqué. *Chemistry*.—Prix Jecker, MM. Béhal and Meunier. Prix La Caze, M. A. Joly. *Geology*.—Prix Delesse, M. Barrois. *Botany*.—Prix Bordin, M. Léon Guignard. Prix Desmazières, M. Auguste-Napoléon Berlese. Prix Montagne, M. Henri Jumelle. Prix Thore, MM. J. Costantin and L. Dufour. *Anatomy and Zoology*.—Grand Prix des Sciences Physiques, M. Jourdan. Prix Bordin, M. Beauregard. Prix Savigny, Dr. Lionel Faurot. Prix Da Gama Machado (not awarded). *Medicine and Surgery*.—Prix Montyon, divided between MM. Dastre, Duroziez, and Lanne-longue; mentions were accorded to MM. Sanchez-Toledo and Veillon, to M. Soulier, and M. Zambaco; and citations to MM. Arthaud and Batte, M. Batemann, MM. Bloch and Londe, M. Catsaras, M. Deberrie, M. Garnier, M. Gautrelet, and M. Netter. Prix Barbier, M. Tscherning; mentions were accorded to MM. Delthil and Dupuy. Prix Bréant (not awarded). Prix Godard, M. Porier; honourable mention to Dr. Wallich. Prix Chaus-sier, Dr. Brouardel; honourable mention to the late M. E. Duponchel. Prix Bellion, divided between MM. Carlier and Mireur. Prix Mége, M. Frédéric Courmont. Prix Lallemand, divided between MM. Gilles de la Tourette, H. Cathelineau, and F. Raymond; honourable mentions were accorded to MM. Legrain, Deberrie, and Le Fort, Bruhl, Sollier, and Colin. *Physiology*.—Prix Montyon, MM. Bloch and Carpentier; mentions were accorded to MM. Hédon and Lesage. Prix La Caze,

M. S. Arloing. Prix Pourat, M. Gley. Prix Martin-Damour-ette, M. Gley. *Physical Geography*.—Prix Gay (not awarded). *General Prizes*.—Prix Montyon (unhealthy industries): the principal portion of this prize was awarded to M. Gréhan, and the remainder was divided equally between MM. Bay and Brousset; honourable mention was made of MM. Bédoin and Lechian. Prix Cuvier, the Geological Survey of the United States. Prix Frémont, M. Emile Rivière. Prix Gegner, M. Paul Serret. Prix Jean Reynaud, the late M. George-Henri Halphen. Prix Petit d'Ormy (Sciences Mathématiques), M. Edouard Gourlat. Prix Petit d'Ormy (Sciences Naturelles), M. Léon Vaisant. Prix de la Fondation Leconte: a prize was accorded to M. Douliot. Prix Laplace, M. Champy.—The following prizes were proposed for the years 1892-1896:—*Geometry*.—Grand Prize for Mathematical Sciences: determination of the number of prime numbers inferior to a given quantity. Prix Bordin: study of the surfaces of which the linear elements may be reduced to the form

$$ds^2 = [f(u) - \phi(v)](du^2 + dv^2).$$

Prix Bordin: applications of the general theory of Abelian functions to geometry. Prix Franceour. Prix Poncelet. *Mechanics*.—Extraordinary Prize of 6000 francs: any improvements tending to increase the efficiency of the French naval forces. Prix Montyon. Prix Plumey. Prix Dalmont. Prix Fourneyron: historical, theoretical, and practical study of the bursting of fly-wheels. *Astronomy*.—Prix Lalande. Prix Damoiseau: improvements of the lunar theory with reference to secular inequalities caused by planets; to see also if any sensible inequalities exist in addition to those already known. Prix Damoiseau: improvements in the methods of calculating perturbations of asteroids which are necessary for the representation of their position within a few minutes of arc, in an interval of fifty years; also to construct numerical tables which will allow the quick determination of the principal parts of the perturbations. Prix Valz. Prix Janssen. *Physics*.—Prix L. La Caze. *Statistics*.—Prix Montyon. *Chemistry*.—Prix Jecker. Prix L. La Caze. *Mineralogy and Geology*.—Grand Prix des Sciences Physiques: an exhaustive study of a question relative to the geology of a part of France. Prix Bordin: the genesis of rocks, exemplified by experimental synthesis. Prix Vaillant: applications of the examination of optical properties to the determination of mineral species and rocks. Prix Delessé. Prix Fontannes. *Botany*.—Prix Barbier, Desmazières, Montagne, de la Fons Melicoco, and Thore. *Agriculture*.—Prix Morogues. *Anatomy and Zoology*.—Prix Thore, Savigny, and Da Gama Machado. *Medicine and Surgery*.—Prix Montyon, Barbier, Bréant, Godard, Serres, Chausser, Parkin, Bellion, Mège, Dusgate, and Lallemand. *Physiology*.—Prix Montyon. Prix L. La Caze. Prix Pourat: experimental and chemical researches on the inhibition phenomena of the nervous shock. Prix Pourat: researches on the effects of subcutaneous or intra-vascular injections on the normal liquids of the organism or on liquid extracts from different tissues or organs. Prix Martin-Damour-ette. *Physical Geography*.—Prix Gay: study of terrestrial magnetism, and, in particular, the distribution of the magnetic elements in France. Prix Gay: study of the trajectory of cyclones moving from North America or the West Indies. *General Prizes*.—Prix Montyon (unhealthy industries), Cuvier, Trémont, Gegner, Delalande-Guérineau, Jean Reynaud, Jérôme Ponti, Petit D'Ormy, Leconte, Tchihatchef, and Laplace.

## BRUSSELS.

Academy of Sciences, October 10.—M. F. Plateau in the chair.—Note on a number of Hyperooods stranded in the Thames and on the Normandy coast, by P. J. Van Beneden.—Study of heat and light phenomena accompanying electrolysis, by E. Lagrange et Hoho. In an electrolyte of dilute sulphuric acid, a positive electrode having an area of 180 sq. cm. was immersed, whilst the negative electrode consisted of a wire of copper 0.25 mm. in diameter, submerged to a depth of 0.5 mm. below the level of the liquid. On passing a current from accumulators through the electrolyte, the ordinary phenomena of electrolysis were observed. When the electromotive force was increased, a kind of decrepitation, resembling the fizzing noise which is heard when drops of water fall on a hot metal plate, was produced at the negative electrode. The liquid about this electrode appears to be in a state of ebullition. The phenomena increased in distinctness as the difference of potential between the negative electrode, and a point in the liquid 3 mm. from it, approached

16 volts. At intervals, when the difference of potential had reached 16 volts, a number of luminous points were produced between the electrode and the liquid, and their frequency was found to increase with the difference of potential. The author has studied the phenomena, using electrodes of Pt, Cu, Zn, Sn, Fe, and Co of different diameters, and electrolytes of different degrees of dilution and different natures. He finds, among other things, that the phenomena commence when the electromotive force is the same (for a given degree of acidity) whatever the nature of the electrolyte. The intensity of the current increases, *ceteris paribus*, with the sections of the electrodes, and varies with the nature of the electrode. For the same degree of acidity, the same electrode, and the same amount of immersed surface, the intensity of the current tends to remain constant, although the electromotive force varied from 76 to 98 volts.—On the case in which two hemihedric conjugate forms are not superposable; conditions necessary and sufficient for a polyhedron to be superposable on its image seen in a plane mirror; possible existence in crystals of a class of hemihedra giving superposable conjugate forms, although possessing neither centre nor plane of symmetry; direct and inverse symmetry; tetrahedric group of the quadratic system represented by A-4, by C. Cesaro.

## BOOKS AND PAMPHLETS RECEIVED.

BOOKS.—Die Elementarstruktur und das Wachstum der Lebenden Substanz: Dr. J. Wiesner (Wien. Hölder).—Magnetism and Electricity; 2nd edition, elementary stage: J. Spencer (Perical).—Arithmetic for Schools: C. Smith (Cambridge University Press).—The Story of the Hills: Rev. H. N. Hutchinson (Seely).—A History of Epidemics in Britain from A.D. 664 to the Extinction of the Plague: C. Creighton (Cambridge University Press).—Indigestion: Dr. T. Dutton (Kimpton).—Studies in Rascatching: H. C. Barkley (Murray).—The Century Dictionary, 6 vols. (Irwin).—Year-book of Pharmacy, 1891 (Churchill).—Società Reale di Napoli: Atti della Reale Accademia delle Scienze Fisiche e Matematiche, serie seconda, vol. 4 (Napoli).—Theory of Heat: J. Clerk Maxwell, 10th edition (Longmans).—Journeys in Persia and Kurdistan, 2 vols.: Mrs. Bishop (Murray).—The Fauna of British India: Mammalia, part 2: W. T. Blanford (Taylor and Francis).—The Collected Mathematical Papers of Arthur Cayley, vol. 4 (Cambridge University Press).

PAMPHLETS.—Old Glasgow. Greater Glasgow: J. B. Russell.—The Character and Influence of the Indian Trade in Wisconsin: Dr. F. J. Turner (Balt).

## CONTENTS.

	PAGE
The Physical Theory of Solution. By J. W. R. . . . .	193
Colour Blindness . . . . .	195
A Meteorological Guide-book . . . . .	196
Our Book Shelf:—	
"Chambers's Encyclopædia," Vol. VIII. . . . .	196
Huxley: "La Place de l'Homme dans la Nature" . . . . .	197
Letters to the Editor:—	
Smithsonian Standards for Physical Apparatus.—Prof. S. P. Langley . . . . .	197
Pigment in Yellow Butterflies.—F. Gowland Hopkins . . . . .	197
The Chromosphere Line $\lambda$ 6676.9.—Prof. C. A. Young . . . . .	198
Grafts and Heredity.—Prof. George Henslow . . . . .	198
Mental Arithmetic.—Dr. K. Haas . . . . .	198
The Migration of the Lemming.—W. Duppacrotch . . . . .	199
The Recent Earthquake in Japan.—Prof. F. A. Forel . . . . .	199
On the Virial Equation for Gases and Vapours. By Prof. P. G. Tait . . . . .	199
On the Relation of Natural Science to Art. I. By Prof. E. du Bois-Reymond, F.R.S. . . . .	200
Telescopic Objectives. (Illustrated.) By A. Fowler . . . . .	204
Notes . . . . .	207
Our Astronomical Column:—	
The Secular Variation of Latitudes . . . . .	210
The Rotation of Venus . . . . .	210
Stars having Peculiar Spectra . . . . .	210
The Tower of Babel and the Confusion of Tongues. By Theo. G. Pinches . . . . .	210
A Year's Scientific Work in New Guinea . . . . .	211
A Medium for Preserving the Colours of Fish and other Animals . . . . .	212
Scientific Serials . . . . .	212
Societies and Academies . . . . .	212
Books and Pamphlets Received . . . . .	216

THURSDAY, JANUARY 7, 1892.

## INDIAN METEOROLOGY.

*Report on the Meteorology of India in 1889.* By John Eliot, M.A., Meteorological Reporter to the Government of India. Fifteenth Year. (Calcutta: Government Press, 1891.)

*Reports on the Administration of the Meteorological Department of the Government of India, 1885-1891.* (Calcutta, Government Press.)

MR. ELIOT'S Report on the meteorology of India in 1889 is much more than a mere mass of statistics, the raw material for future utilization—more than a retrospective summary of the weather phases and incidents of the year, which may or may not be turned to future account; by someone gifted with that scientific imagination that alone can infuse life and meaning into the dry bones of our voluminous weather records. These, indeed, it gives with the usual fulness—not in the fragmentary fashion of a gallery of cabinet studies, but with something of the continuity and breadth of a diorama; and over and above these, it deals with many topics of general interest, which are real and valuable contributions to the body of the science, and on which the remarkably favourable conditions of India—a great tropical country dotted over with a well-organized system of observatories under the direction of a competent physicist—are peculiarly fitted to throw light.

Foremost among these, stands the question of the incident solar heat, which is at once the most important, and at the same time one of which we have the least exact knowledge. To this question more attention has been given by the Meteorological Department of India than by that of any other country; and if we must regretfully admit that the results bear but a small proportion to the labour expended on obtaining them, the experience gained of the difficulties attending the inquiry is not without its value.

Some years ago it was thought that the position of Leh, in the dry climate of Western Tibet, 11,500 feet above the sea, offered peculiar facilities for obtaining trustworthy measurements of the solar heat; and in 1882, Sergeant Rowland, a highly intelligent officer of the Royal Engineers, was selected in England, and after a year's careful training at Roorkee in the use of Balfour Stewart's actinometer, under the personal superintendence of Mr. J. B. N. Hennessey, was despatched to Leh, together with a European assistant, who had been equally trained to the work. They were furnished with elaborate instructions, drawn up by Mr. Hennessey, which contemplated observations of two classes. On all clear days observations were to be taken at noon, and also once in the morning and once in the afternoon, with the sun at certain definite altitudes; and on certain selected days (from one to six in each month) similar observations were to be taken at short intervals in succession during so many hours as the altitude of the sun should exceed a certain assigned minimum. The observers remained at Leh nearly two years, and undoubtedly accomplished all that

it was possible to do under the circumstances of the climate; but this proved to be little, if at all, superior to that which might have been obtained at some of the easily accessible stations of the outer Himalaya, and the total outcome of the twenty-three months' work was seven complete series recorded at short intervals, and sixty of the tri-daily measurements, together with fifteen incomplete series of the former and ninety-five of the latter, which had been more or less interrupted by the obscurity of the sky. Moreover, the instrument by no means answered to the expectations of the inventor. Its chief apparent recommendation was the simplicity of its manipulation; but it was found to require careful attention to a number of minute and elaborate details in order to insure that the observations should be comparable *inter se*, and although the registers obtained were examined and discussed by Prof. Balfour Stewart shortly before his death, they were not found to lead to any definite conclusions of such importance as to justify their publication.

Notwithstanding the discouraging results of this expedition, the investigation has not been abandoned. After Sergeant Rowland's return from Leh, actinometric observations were carried on during the clear season at Mussoorie, and lately under Mr. Eliot's supervision at Simla, and the late Prof. Hill was engaged in the examination of some of this later work, when it was brought to a standstill by his premature death. It is, we believe, now contemplated to make actinometric and other physical observations a part of the future work of the Madras Observatory, and with that view, and also in the interests of astronomy, to transfer the Observatory to some suitable site on one of the lofty hill-groups of Southern India, a step long since recommended on general grounds.

From the first establishment of the Indian Meteorological Department, the sun-thermometer *in vacuo* has formed part of the equipment of every observatory; and every instrument, before being issued, has been subjected to a prolonged comparison with an arbitrary standard, in order to evaluate the mean effect of those irregularities which affect the readings of all instruments of this class, and in many cases amount to differences of  $15^{\circ}$  and more between thermometers constructed by the best makers. This precaution, however, has proved inadequate. It has long been known that the average readings of many of these instruments undergo a considerable decline in the course of a few years, and that in many cases the glass of the inclosing jacket becomes gradually opaque. During the year 1889, twenty-four observatories were each provided with three carefully compared instruments of different ages, and the observers were instructed to take the observations as accurately as possible. Mr. Eliot says:—

“The results of the three instruments exposed under identical conditions were in the great majority of cases so widely discrepant as to show that the instrument, from defects in its construction, cannot, at least under the conditions of its employment in India, be relied upon to give consistent and reliable results.”

The late Prof. Hill subjected these registers to a critical examination, and his conclusions, being based on the results of seventy-two instruments, may be taken as fairly

representing the average behaviour of thermometers of this class. He says:—

“A few days' observations under identical conditions are not sufficient to determine the correction with any approach to accuracy. The thermometers are so variable in their indications, that, in one ordinary case that I worked out, it would seem that at least forty-four months' comparative readings would be required to furnish an average correction with a probable error of only one-tenth of a degree. The differences between the indications of two thermometers placed side by side are in very many instances subject to an annual variation, showing that the correction to a common standard cannot be made by adding or subtracting a fixed quantity, but that the amount of this correction is variable, and perhaps capable of being expressed as a function of the temperature indicated. The older instruments, even after correction, on the whole give lower readings than the new ones. Some of the latter, when compared with the oldest thermometers of the set, appear to fall off considerably in sensitiveness even in the short period of twelve months. . . . But sometimes an instrument two or three years old decreases in sensitiveness more rapidly than a perfectly new one; sometimes also an instrument, after remaining nearly constant in its indications for several months, as compared with the oldest of the set, suddenly shows a rapid and unaccountable falling-off in sensitiveness.”

And he concludes:—

“The indications of the instruments are thus in most cases totally unreliable, and the observations comparatively worthless. The only possible exceptions I can see to this sweeping condemnation are observations made with instruments which have been in constant use for ten years or more, and which may perhaps be assumed to have arrived at a constant condition as regards sensitiveness.”

Since the average duration of a sun-thermometer, under the conditions of Indian observatories, is only about three years, it is obvious that instruments that have stood the prescribed test can be but few. But it was with such a thermometer that were obtained the valuable results published by Mr. Hill in the *Journal of the Asiatic Society of Bengal* in 1883 and 1886, which afford the only direct evidence yet on record of an eleven-year variation of the solar heat.

The duration of sunshine has now been recorded at five Indian Observatories with the Stokes-Campbell sunshine recorder for periods of from four to seven years, and the average results are given in Mr. Eliot's Report, together with those of the year 1889. The stations are all in Northern India, one only, Calcutta, being within the tropics. Allahabad and Lahore show the highest proportion of sunshine, viz. 69 and 68 per cent. respectively of the possible maximum. Jeypore has but little less, viz. 65 per cent. Calcutta follows with 59 per cent., and Dehra, at the foot of the Himalayas, shows the lowest average, viz. 49 per cent. At St. Aubin's, in Jersey, the sunniest station in the British Isles, the proportion is 39 per cent. In the absence of any record from Southern India, it cannot be positively asserted that the Indo-Gangetic plain is the sunniest portion of India, but judging from the registers of cloud proportion, which are regularly kept at all Indian stations, there can be but little doubt that such is really the case.

Another kind of observations nearly related to the above are those of the temperature of the ground. These

have been made at the same five Observatories that have furnished the sunshine records: at Calcutta since 1878, and at the other stations during periods of from four to ten years. One feature is common to all of them. In all cases the mean temperature of the ground is some degrees higher than that of the air, the excess varying, however, considerably at different stations, and at the same station in different years, as well as, of course, at different seasons of the year. This general fact was observed many years ago by the late J. Allen Broun at Trevandrum, and has also been known for some years in the case of Calcutta and Allahabad; and it was remarked by the late Prof. Hill that it is probably characteristic of hot climates in general. He considered it probable that there is

“a difference in the opposite direction between the air and ground temperatures in high latitudes; for, owing to the circulation of the atmosphere, and the constant mixing together of its several parts, the air temperature must be more uniform all over the earth than it would be were it determined for each place solely by the balance between insolation and loss of heat by radiation into space; while the temperature of the ground is more directly dependent on the balance between the gain and loss of heat by radiation.”

I am not aware that this interesting speculation has hitherto been verified.

According to the present registers, Jeypore (where the ground consists of loose dry sand) shows the greatest excess of ground surface temperature, viz.  $6^{\circ}3'$  on the mean of the year; and at Lahore (where the ground is a sandy loam) it is as much as  $5^{\circ}8'$ . At Allahabad it appears to be about  $3^{\circ}8'$ , and at Calcutta  $2^{\circ}7'$ . It is therefore in a great measure dependent apparently on the dryness of the climate, since the mean annual rainfall of these four places is 25, 21, 38, and 62 inches respectively, and the mean relative humidities 50, 50, 61, and 77 per cent. of saturation. The ground temperatures here considered are those of the surface. At Calcutta the temperature increases rapidly with the depth, so that at 3 feet deep it is  $1^{\circ}5'$  warmer than at the surface, and at 6 feet  $1^{\circ}6'$  warmer. This is probably to be attributed to the decomposition of organic matter, with which a bed of foetid quicksand at a depth of 40 or 50 feet is highly charged, and which, when freshly excavated, is distinctly warm to the touch.<sup>2</sup>

At other stations there appear to be some remarkable irregularities in the temperatures at different depths. Thus at Allahabad the average warmth of the ground decreases  $1^{\circ}7'$  between the surface and the depth of 1 foot, and then increases  $1^{\circ}2'$  to a depth of 3 feet; at Jeypore it decreases  $3^{\circ}3'$  down to 1 foot, and then increases, but somewhat irregularly, by a total amount of  $0^{\circ}6'$  to a depth of 20 feet; and at Lahore it decreases  $1^{\circ}5'$  to a depth of 1 foot, and increases again  $0^{\circ}7'$  to 3 feet. In the case of Allahabad, the temperatures of which were fully discussed in a memoir by the late Prof. Hill,<sup>3</sup> some of these minor irregularities

<sup>1</sup> Most of the figures quoted in this paragraph differ from those given in Mr. Eliot's Report. In the Report the comparison is made between the mean ground temperature of a few years and that of the atmosphere deduced from three or four times as many, and in some cases the conditions of the Observatory have been changed. The figures in the text are derived from a comparison of the same years.

<sup>2</sup> This bed extends apparently everywhere beneath Calcutta, and is the cause of great instability to the more ponderous edifices, of which the great Imperial Museum affords a striking example. In fact, in a certain sense, Calcutta may be said to be a floating city.

<sup>3</sup> *Indian Meteorological Memoirs*, vol. iv., Part iii., No. v., “On the Ground Temperature Observations made at the Observatory, Allahabad.”

were shown to be the result of the flux and reflux of waves of heat as hotter or colder years alternated, the effects of which were by no means eliminated in the five or six years over which the record extended. But the remarkable diminution of temperature from the surface down to 1 foot cannot be thus explained. It appears at all the stations, for even at Calcutta there is an increase of only  $0^{\circ}2$  in the first foot below the surface, and then an increase of  $1^{\circ}3$  between 1 and 3 feet; and it appears to be independent of the character of the surface, which at Calcutta is grassy, and at Jeypore pure sand absolutely without vegetation. At Calcutta and Allahabad, the 1-foot thermometer as originally installed was found to have its temperature lowered by air-convection at night in the tube around the thermometer; but steps were taken to prevent this both at these and the other Observatories, and the invalidated registers were rejected. Yet it is difficult to imagine the existence of any cooling agency which should keep the temperature at 1 foot below the surface on an average  $1^{\circ}$  or  $2^{\circ}$  lower than either above or below that level, and the matter certainly requires further investigation.

The foregoing remarks deal with subjects which, although intimately connected with meteorology, lie somewhat apart from the ordinary field of meteorological observation. There is, however, very much in Mr. Eliot's Report, on the more familiar class of subjects usually dealt with by meteorologists that is well worthy of reproduction, especially the characteristic phenomena of Indian storms, which Mr. Eliot has made the object of his special study. These must be reserved for another notice.

The frequent reference in the foregoing paragraphs to the admirable work of the late Prof. Hill (and, after all, but few of the many subjects have been noticed to which his active mind contributed so largely) forcibly brings before me how great a loss has been sustained by Indian science in his premature death—a loss the more conspicuous in a country where the workers are so few and the field of research so large and fruitful. It is but a sad consolation to offer this slight tribute to the memory of a man who was as modest and amiable as he was able and accomplished as a devotee of science; but all who know his work will cordially re-echo the words of the Governor-General in Council—that the Meteorological Department of India “lost in him an officer whose industry, talent, and technical knowledge it will be hard to replace.”

H. F. B.

#### FRENCH MALACOLOGY.

*Les Coquilles marines des Côtes de France; description des familles, genres, et espèces.* Par A. Locard. Pp. 384; 348 Figures in Text. (Paris: Baillière, 1892 [or rather 1891].) Also issued as tom. xxxvii. (1891) of the *Annales de la Société Linnéenne de Lyon*.

MORE favourably situated than these isolated and comparatively chilly shores, France possesses a Molluscan fauna which numerically is richer far than ours; whilst her political boundaries embrace portions of two terrestrial regions and two marine Molluscan provinces.

The land regions (Germanic and Lusitanian) yield probably something under 300 species. The last trustworthy work, that by Moquin-Tandon, describes 266 species—219 being terrestrial and 47 fresh-water forms.

The marine provinces are the Celtic and Lusitanian. The former includes the greater portion of the English Channel, and is common ground, therefore, to ourselves and our neighbours. The latter, especially the Mediterranean as distinguished from the Atlantic version of it, furnishes the French conchologist with his happiest hunting-ground. Nearly 1200 species are to be found in the Mediterranean, and another 150 (besides 478 common forms) on the Atlantic coast.

In contrast with this abundance of Molluscan life, all that we can boast is some 550 marine and 130 non-marine species.

Whilst, however, the material obtainable by the French conchologist is thus plentiful, the literature at his disposal for purposes of research and identification is by no means so complete as that which lies ready to the hand of his British *confrère*. The French Forbes and Hanley, or even Jeffreys, has yet to be compiled; no single work exists giving adequate descriptions, with synonymy, notes, and figures.

For the non-marine species Moquin-Tandon's careful work remains unsurpassed: for the whole subject the only approach yet made consists of the three volumes by M. Locard, of which the one now under consideration forms the last. The first two were issued under the title “*Prodrome de Malacologie Française, Catalogue général des Mollusques vivants de France*,” and dealt respectively with the land, fresh- and brackish-water Mollusca, and with the marine. In these volumes the author gave no descriptions: a synonymy of each species, with references to the best descriptions and figures, and a list of the French localities, were all that appeared. In the present work M. Locard proposes to supply this deficiency, so far as the shells of the marine testaceous Gastropoda, Pelecypoda, and the Brachiopoda are concerned, by furnishing a concise—mostly too concise—description of each species, and a more detailed description, with a figure, of the typical forms of each genus and section, or “groupe” as he terms it, thereof. The synonymy and the bibliography are not repeated, and so each work remains incomplete without the other, and double reference is entailed—a process which is always vexatious.

Unfortunately, too, the subject is conceived exclusively from a shelly point of view; indeed, the fact that the shells ever had an animal origin and connection, is most skilfully concealed in the body of the work, and the ‘nasty creature’ is only alluded to when, in the introduction, it becomes necessary to refer to its habitat, or to describe the method of its elimination prior to the deposition of the all-precious tenement in the cabinet. To such a point is this persistent ignoring of the animal carried, that, in defining the topography of a bivalve shell, the customary and intelligible terms “right” and “left valve” are discarded in favour of the arbitrary designations of “upper” and “under,” a nomenclature derived from their position when the shell is placed on its side upon the table with the umbones pointing towards the left.

The result is that, whilst in the majority of instances the upper is equivalent to the left valve, in *Nucula*, which is opisthogyre, the author has 'got the head where the tail should be,' and writes, for example, of *N. sulcata* (pp. 329-30): "région antérieure presque droite, très étroite; région postérieure très développée, oblique." It is only fair to add that in *Donax*, thanks to the presence of the well-marked external ligament, this error is avoided.

The author's recognition in his introduction that every species is liable to variation, and his wise resolve not to cumber his book with trashy "varieties," founded merely on differences of colour or size, that have of late been so fashionable in certain quarters, is satisfactory; but it is greatly to be regretted that the process of elimination was not carried a step further. A very slight acquaintance with the animals, or even a cursory inspection of a fairly extensive series of examples of the shells of the individual species, would have been sufficient to convince any unprejudiced person that a very large percentage indeed of the "species" cited in this volume are but mere varieties, and unworthy of specific rank; at the same time we confess to some fear that all argument and instance would be lost on one who but lately has sought to divide so homogeneous a species as *Helix rufescens* into six! The principle adopted seems, in fact, to be, judging from numerous instances in the pages before us, to raise species into "groupes," and varieties into "species" (save the mark!). This is certainly the case in the genera *Nassa*, *Purpura*, *Mytilus*, &c.

It is little wonder under these circumstances, then, that M. Locard's three volumes should represent the French Molluscan fauna as including close upon 1500 marine and 1250 odd non-marine "species"! This may all be very magnificent; but it is not science!

The systematist will also have much cause to complain of the classification adopted, which is certainly not in accord with the latest views of the biologist. The extreme stickler for priority in nomenclature, of whom we have lately heard a good deal, will exclaim loudly against many of the names, though, since full reference to the authority is given in each case, there is perhaps not quite so much to find fault with, although the references are not always accurate.

On the other hand, we feel convinced that no one will approve certain arbitrary changes in the nomenclature, first proposed without comment or explanation in footnotes in the "Prodrome . . . Mollusques marins" (1886), but here introduced into the text itself. M. Locard appears to entertain special objection to the use of a substantive as a specific name, and converts it into an adjectival form, at the same time retaining the name of the original author as its sponsor! For example, *Purpura lapillus* appears as *P. lapillina*; *Nassa granum* is changed to *N. graniformis*; *Murex nux* into *M. nucalis*; *Aporrhais pespellicani* masquerades as *A. pelecaniipes*; *Pholas dactylus* is turned into *P. dactylina*. We also find *Cassia Saburon* altered to *C. Saburoni*; and *Murex scalaroides* to *M. scalariformis*.

It would be interesting to learn on what principle, if any, these alterations are made, since some names that might apparently be equally objected to are left (fortunately) untouched; whilst M. Locard's own names are

not always unexceptionable, as witness *Murex Brandariformis*.

If we comment thus strongly and at unmerited length upon this production, it is not because we mean to imply the work is altogether without merit, nor because we fail to recognize the honesty of the attempt. It doubtless to a certain extent supplies a want, and helps to fill a void: it is well printed and on good paper, with a good index, and some of the little illustrations are excellent.

The subject, however, is a worthy one, and deserving of broader, and, we regret to have to say it, more scientific treatment. This work, like Paetel's "Catalog" is a mere shell-collectors' book. What every student of the subject must desire to see is a really good treatise, worthy of the best traditions of French scientific work, and of the land of the illustrious Lamarck; one which shall do for systematic French malacology as a whole what Moquin-Tandon did for the terrestrial portion as known to him; and one that shall be done with the same conscientious care which distinguished that eminent naturalist, and which is characteristic of the work of Lacaze-Duthiers, himself one of the last of a long line of those distinguished biologists whom France has produced, and of whom she is so justly proud. (BV)<sup>2</sup>.

#### MAN'S PLACE IN NATURE.

*Nature and Man in North America.* By N. S. Shaler. Pp. 290. (London: Smith, Elder, and Co., 1892.)

PROF. N. S. SHALER, in the introduction to his new volume, gives a sketch of the plan of the work, and as there seems to be some want of connection between the different chapters, we prefer to quote the author's own words as to the object he has in view. He writes (p. vi.) :—

"It seems to me to be the duty of every naturalist, particularly when he has adopted the tasks of the teacher, to use each fit occasion to show wherein he finds proof of a just confidence as to the relations of man to the creative power which works in Nature. By so doing, he may hope to help himself and his fellow-students to escape from the perplexity which has been brought about through the revolution in the opinions of men which modern science has induced. With this end in view, I shall devote the first four chapters of this book to a general statement concerning the effect of critical conditions of the earth on the development of organic life in general. It will be my aim to show that geographic changes and the consequent revolutions of the climate which our earth has undergone, though rude and in a way destructive, have nevertheless served the best uses of life, driving organic creatures by the whips of necessity upward and onward toward the higher planes of being.

"I shall give the latter half of this essay to the discussion of geographic influences upon man, endeavoring to show, at least in a general way, how the development of race peculiarities has been in large part due to the conditions of the stage on which the different peoples have played their parts. I shall endeavor to trace in outline the effect of the geographic conditions on the development of peoples in the past, and to make a somewhat careful study of these problems as they are exhibited in North America."

Less than half of Prof. Shaler's book is devoted to Nature and man in America, but this part is decidedly the best, and shows more signs of care than the earlier chapters. For these reasons, and because the title of the

volume shows that the last hundred pages include the more important part, we will first deal with chapters v. to viii.

Beginning with a sketch of the dependence of man on his environment, the author proceeds to an account of the effect of environment on the development of various races. To the English reader one of the most interesting parts of chapter v. will be the account of the effect of the isolation and other physical peculiarities of Britain on the development of the English race.

In chapter vi. the author more especially deals with the dependence of the native races of North America on geographical and climatic conditions. This section leads by a natural transition to the competition between the white colonists and the Indians, and to the effect of barriers and strongholds in retarding or helping the gradual spread of the white races in North America.

Chapter vii. deals mainly with the relation of man to soils and climate, with the introduction of the negro race, and with the extent to which the negro and the white races are likely to compete.

In chapter viii., Prof. Shaler turns to the sparsely inhabited regions west of the Mississippi, and here he treats mainly of the capabilities for settlement of tracts still untried by white men. He speaks of the climatic conditions, of the probable value of the soils, of the reclamation of the arid regions by irrigation, and of the probable fitness of the Western States for permanent settlement by men of Aryan race: he concludes that this part of America is capable of sustaining an enormous population, and that white men can thrive in most parts of it.

To those who have not read Prof. Shaler's articles in *Scribner's Magazine*, we can recommend the last four chapters of his book as giving an interesting and readable account of man's relation to Nature in North America. The first four chapters we cannot praise: they seem to be largely made up of miscellaneous notes hastily put together with little arrangement and without careful revision; they swell the bulk of the volume, but bear only remotely on the relation between Nature and man in North America.

Chapter i. treats mainly of the zoological and botanical provinces of the present day, and their dependence on physical barriers and on climate. These pages are full of interspersed suggestions as to what might have been if conditions had been different, but some of these suggestions do not seem to have been carefully thought out, and sometimes the author adopts irreconcilable views in other parts of the same volume. We find, for instance, numerous speculations as to the effect that would be produced by the diversion of the Gulf Stream, and, among others, the following passage, in which, after speaking of the lowering of the initial velocity that would follow from a submergence of the peninsula of Florida, the author observes (p. 21):—

"It is mainly, if not altogether, to this initial velocity that we owe the efficiency of the Gulf Stream as a warmth-bringing current in high latitudes."

But on p. 129 we read:—

"It is a well-known fact that our oceanic streams are, in the main at least, a consequent of the movement which the air has in the trade-winds of the tropical district."

The author apparently does not observe that if the trade-winds are the main cause of the equatorial current, it is probable that the persistent south-westerly winds of the North Atlantic may also have much to do with the ocean current which follows the same course.

In chapter ii., Prof. Shaler speaks of the nature and origin of continents, development of life, mountain growth, saltness of the sea, &c.; and in chapter iii., of the permanence of continents, including a sketch of the position of the shore-lines from pre-Cambrian times to the Glacial epoch. Chapter iv. deals with a great variety of subjects, such as the condition of the fauna and flora in Cambrian time, Croll's theory of the origin of coal-measures, conditions of continental growth in Europe, uniformity in past time of the composition of the atmosphere, and variations in the Gulf Stream.

Prof. Shaler, in his first four chapters, deals so largely with questions relating to the geographical distribution of animals and plants, that it surprises us to find a good many statements which more care in revision would certainly not have allowed to pass. Thus, speaking of local forms that must be developed through the long-continued competition of different assemblages brought into close proximity in a mountainous district, the author remarks (p. 27) that:—

"In a continent such as Europe, where a great diversity in the mountain systems favours the localization of life and the development of peculiar forms, the tendency is to develop in separate mountain strongholds particular species, and evolve their militant peculiarities until the forms are fitted to enter into a larger contention with their kindred species in less localized assemblages of life."

The example is most unfortunately chosen, for of all the continents Europe least illustrates the process; one would have thought that no naturalist would have brought forward the Europe of the present day as a good illustration of the differentiation of species on mountains and in isolated valleys. Our Alpine flora and fauna, instead of varying greatly on the different chains, are more remarkable for their uniformity over all the continent. Our valleys seldom, if ever, contain plants and animals of local origin, for the Glacial epoch is of too recent a date for many local forms to be developed, and has affected Europe too seriously to allow many pre-glacial forms to survive in their original limited stations. Had Prof. Shaler pointed to the mountains of sub-tropical and tropical America, with their local species of humming-birds, we should not have objected. We have marked many other equally questionable statements, which it is surprising to find made on the authority of Prof. Shaler.

The occurrence of various statements of doubtful accuracy, the debatable character of much of the evidence, and the complicated nature of the questions dealt with, make us hesitate to endorse the author's opinion that this book "is particularly designed for the use of beginners in the study of geology." Speculations as to what might have been if conditions had been different are scarcely suitable for the beginner in any branch of natural science. The skilled naturalist or geologist, able to discriminate, may obtain useful hints from the present volume. C. R.

## OUR BOOK SHELF.

*Stones for Building and Decoration.* By George P. Merrill, Curator of Geology in the United States National Museum. (New York: John Wiley and Sons, 1891.)

THIS work deals almost exclusively with the building and ornamental stones of the North American continent, the references to similar rocks in Europe and elsewhere being usually meagre and sometimes disappointing. As an account of the rocks of the United States which are of economic importance as building materials, the work is, however, a very admirable one; and, as might have been expected in a treatise bearing the name of so well-known an authority as Mr. Merrill, the book is replete with valuable information both to the geologist and the architect.

Mr. Merrill gives, in the introduction to his work, an interesting sketch of the gradual substitution of stone for wood as a building material among the early settlers in New England, and then proceeds to sketch the distribution of the different varieties of building stones in the several States and Territories of the Union. The chapters which follow, on the minerals of building stones, and on the physical and chemical characters of the rocks which are employed in construction, are very admirably written; and the illustrations of the microscopical structure of building stones, and the remarks on the nature and causes of disintegration in different varieties, being alike excellent.

In classifying building materials, Mr. Merrill very wisely adopts a combination of practical and scientific methods. Among the crystalline and vitreous rocks, he distinguishes, in the first place, those which are simple or made up of one mineral only—namely, steatite and soapstone, serpentine (including the verdantique marbles), gypsum (including alabaster and satin spar), and limestones with dolomites. In dealing with the compound rocks, or those built up of several different minerals, Mr. Merrill adopts the usual petrographical distinction of massive and schistose (or foliated) rocks. The former he divides into the four groups of rocks containing free quartz, rocks without quartz, but containing orthoclase felspar, rocks with plagioclase felspar, and rocks without felspar. The fragmental rocks are divided into the psammites (sandstones, &c.), the pelites (clays, &c.), the volcanic tuffs, and the rocks built up by organisms.

The chapters on the methods of quarrying, working, and testing building stones are especially admirable, and the illustrations of the great quarries of the United States, reproduced from photographs, are of great interest. The remarks on the processes which have been devised for the protection and preservation of building stones, and the tables giving the crushing strength, specific gravity, ratio of absorption, and chemical composition of all the chief varieties of building stone employed in the United States, cannot fail to be of great value to practical men. It would be hard to find a more admirable example of the value of exact scientific knowledge when applied to the treatment of economic questions than is afforded by the work before us.

*Les Champignons.* Par A. Acloque. (Paris: J. B. Baillière et Fils, 1892.)

THE author of this book has found much to interest him in the study of his subject, and he communicates in a clear, pleasant style the leading facts and laws which have been brought to light by mycologists. Having presented in an introductory chapter some general considerations, he proceeds to deal with the subject from the anatomical, the physiological, and the economical points of view. Finally he gives a summary of mycological taxonomy. The book belongs to the "Bibliothèque Scientifique Contemporaine," and is in every way worthy of a place among the other volumes of the series.

*Theory of Heat.* By J. Clerk Maxwell. Tenth Edition. With Corrections and Additions by Lord Rayleigh. (London: Longmans, Green, and Co., 1891.)

THIS book is so well known, and has been of such good service to students, that it is scarcely necessary to do more than note the fact that a tenth edition of it has been issued. Only such corrections and additions have been introduced as seemed, in Lord Rayleigh's judgment, to be really called for. They are in great measure derived from Clerk Maxwell's later writings.

## LETTERS TO THE EDITOR.

[The Editor does not hold himself responsible for opinions expressed by his correspondents. Neither can he undertake to return, or to correspond with the writers of, rejected manuscripts intended for this or any other part of NATURE. No notice is taken of anonymous communications.]

## The Implications of Science.

PERMIT me, through your columns, to thank Mr. E. T. Dixon for his letter, which appeared in NATURE of December 10, 1891, p. 125, concerning my lecture on the implications of science, and, very briefly, to reply to it.

He is very much mistaken in thinking that I place our knowledge of "the law of contradiction" and of "our own continuous existence" in the same category. I regard them as truths fundamentally distinct. The former is an abstract principle, the latter a particular fact. Since Mr. Dixon merely affirms without arguing, he must permit me to contradict him, and say that the law of contradiction is a necessary and objective truth—one that does not merely express a "verbal convention," and is not "of the nature of a definition." It is so objective that Omnipotence itself could not violate it—could not, e.g., cause a creature to have at the same time both four and only three legs. But "our continuous existence" is so far from being a necessary truth that, if an Omnipotent Creator exists, there can be no impossibility in our annihilation. That we cannot be annihilated while we know we are actually existing is, of course, true; but that fact, so far from serving Mr. Dixon's argument, is but an example of the validity of the law of contradiction. We cannot at the same time be both "consciously existing" and "absolutely annihilated." My critic seems to be still in bondage to that subjectivism and nominalism wherein I was so long involved, and whence I only extricated myself slowly and with much trouble.

As to memory, I said that we may, as everybody knows, make mistakes, but that nevertheless we are as certain concerning some parts of the past as of the present. Most assuredly I am quite as certain that I read Mr. Dixon's letter as that I am now in the act of replying to it. Our confidence in our memory cannot depend upon induction, because, if we had it not at starting, we could make no induction or enumeration whatever.

My "implications of science" are truths, and not "purely verbal assertions," but I never affirmed any "peculiar certainty" for "mathematical conclusions." Helmholtz has never shown, to my knowledge, that two straight lines could ever inclose a space. Of course, if his supposed "dwellers on a sphere" chose, as Mr. Dixon says, to apply that term to what are not straight lines, different conclusions would follow. No one denies that two curved lines can be conceived of as inclosing a space.

Similarly, if Mr. Dixon's inhabitants of the Dog Star chose, as he again says, "to define four as  $1 + 1 + 1$ ," then for them two and two would not be four. But who was ever so absurd as to suppose they would be? If any persons choose to give to the term "an angle" the signification we express by the words "a mutton chop," then certainly our conception of a triangle would not apply; for three such angles would not be equal to two right angles.

Mr. Dixon is good enough to instruct us that "the law of contradiction never tells us whether anything is or is not." But what man out of Bedlam would suppose that a statement of an abstract general law would inform us about a particular concrete thing? On the other hand, the law of contradiction does not tell us, and never by any possibility could tell us, "that the terms 'is' and 'is not' are not applicable to the same thing"—though



by applying that abstract universal and necessary law to such things as "terms," we see that a term applicable to anything cannot at the same time be the very opposite.

Mr. Dixon says: "If anyone chooses to say a thing both 'is' and 'is not,' there is no law against his doing so, only if he does so he is not talking the Queen's English." But by so doing he breaks the law of reason, if not the law of the land; and, indeed, to act on such a principle when on oath in a court of law might, after all, have inconvenient consequences.

My critic is obliging enough to say in plain and simple terms: "Dr. Mivart is wrong in speaking of the objective absolute validity of the law of contradiction." To this I might content myself by replying: "*Quod gratis asseritur gratis negatur*!" But let us avoid the use of the terms "is" and "is not": they are not necessary for my purpose. Does Mr. Dixon really doubt whether, if he had lost one eye, he would still remain, after that loss, in the very same condition he was in before? If anyone does not see the objective impossibility of such a thing *everywhere* and *coeverywhen*—i. e. if he does not apprehend the application of the law of contradiction—then he either does not understand the question, or his mental condition is pathological. The implications of science are implied. Men may pretend to doubt them, their own existence, or the objectivity of mathematical truths. But their practice shows their unflinching confidence in them on each occasion as it arises—as when cheated by false accounts, personally injured, or engaged in scientific research. When we enter the laboratory, we leave these follies outside.

Hurstcote, December 22, 1891.

ST. GEORGE MIVART.

WILL you allow me to say a few words in reference to four points in Mr. E. T. Dixon's indictment (NATURE, December 10, p. 125) of Mr. St. George Mivart?

(1) Mr. Dixon asserts that the law of contradiction "is not a necessary truth at all, it only expresses a verbal convention"—it "never tells us whether anything 'is' or 'is not.'" It only informs us that the terms 'is' and 'is not' are not applicable to the same thing." But though it may be only a "verbal convention" that in "the Queen's English" *not* is the sign of negation, it is not a mere verbal convention that if a signifies the negation of A (whatever A may stand for), then A and a "are not applicable to the same thing"—as the law of contradiction asserts, and as Mr. Dixon himself allows. A highly abstract law that is concerned with the relations of propositions cannot, of course, tell us whether any particular thing exists or not—but then no one has ever expected that it should; and moreover, assertions (or denials) of the "existence" of particular objects are not the only "real" propositions (Mr. Dixon appears to be misled here partly by the ambiguity of *is*).

(2) Mr. Dixon says that the law of gravitation—like other laws suggested by particular experiences—depends ultimately upon induction *per enumerationem simplicem*; that is, upon an inference of the form *This A is X, that A is X, &c. (= Some A's are X), ∴ All A's are X* (for we can make nothing better out of an induction by simple enumeration). But this inference is merely an immediate inference, and moreover an illegitimate one; hence, according to Mr. Dixon's view, inductions have no logical justification whatever.

(3) Further, Mr. Dixon asserts that "the supposed peculiar certainty of mathematical conclusions is solely due to the fact that they are truisms," or "purely verbal assertions,"—by which I understand him to mean definitions. In answer to this I should maintain that the peculiar certainty of mathematical propositions, and the fact that here, by help of a single instance, we unhesitatingly conclude to the universal, are (as I have observed elsewhere) explicable by "the consideration that we here see at once the connection, which in other cases we believe on grounds very different from a perception of self-evident interdependence of attributes. When the equality of the interior angles of any one triangle to two right angles has been demonstrated to us, we infer without a moment's doubt that the same relation of equality may be asserted of the interior angles of every triangle; and this because we have seen that with the attributes signified by 'the interior angles of a triangle' there is bound up the attribute of 'being equal to two right angles.'" We believe that, if a certain amount of arsenic has on some occasions produced death, it will always produce death, on the ground that the apparent likenesses are connected with unapparent likenesses; but we have not seen in this case (as we have in the case of the triangle) that there is a self-evident

interdependence. And here we see why it is that, in the case of mathematical inductions, we do not need to use Mill's 'Inductive Methods.'"

(4) When Mr. Dixon goes on to say that, "if the inhabitants of the Dog Star defined 'twice,' 'two,' and 'four' as we do, then 'twice two' would be to them 'four'; but to say that it was so could only give verbal information," he may be refuted out of his own mouth. For he goes on to remark that, "if the people in the Dog Star chose to define four as  $1 + 1 + 1$ , the so-called 'necessary truth' would not even be true!" thus showing clearly that it is the facts signified, and not the words which signify them, that we are concerned with. According to Mr. Dixon, it would be (for me) a necessary truth that I have a head-ache, or am writing with a lead-pencil; while mathematical truths, in as far as "real," are obtained by induction, and are therefore not necessary. I hold, on the contrary, that mathematical truths, though obtained by induction, are "necessary"—that is, true under all circumstances—and that it is only by a confusion between "necessary" and "certain" that a statement of the apprehension of present fact can be called a "necessary truth."

E. E. C. JONES.

Cambridge, December 14, 1891.

### Supernumerary Rainbows observed in the Orkneys.

I ENCLOSE a letter just received. The writer has charge of the anemometer formerly kept by the late Dr. Clouston. Dr. Clouston first drew my attention to the extraordinary bow seen at Kirkwall in 1871. My note is in the Quarterly Journal of the Meteorological Society, vol. i. p. 237.

ROBERT H. SCOTT.

Meteorological Office, 63 Victoria Street, S.W.,  
December 31, 1891.

*Deerness Public School, Kirkwall, December 28, 1891.*

SIR,—On reading your very interesting work on "Elementary Meteorology," I find, on p. 201, reference made to "an extraordinary bow" which appeared at Kirkwall, November 13, 1871, which you explain by the reflection of the sun's rays from a water surface.

On Saturday, the 26th inst., at 3.20, when the sun was on the horizon, I saw a very distinct rainbow; there was no trace whatever of the secondary bow, but between where it ought to have been and the primary one there were several patches of what are called "supernumerary" bows. The only colour I saw distinctly was the red.

This lasted for about four minutes, when, finally, a second bow appeared just inside the primary, with the colours arranged as in the primary—not reversed, as the secondary. The space between the violet of the primary and this one was almost *nil*. The red next the violet of the primary was about as distinct as that of the primary. The orange and yellow were distinct also, but the others could hardly be seen. This was, no doubt, owing to the fading light of day, and to the dark colour of the clouds in the north-east, where the bows appeared. These lasted distinctly and complete for about one minute. The bows formed, as is well known, half a circle. The sun was setting behind land at the time, and the wind was blowing at the rate of forty-five miles, so that there could be no water reflection.

If I am not troubling you too much, would you kindly say if this is unusual, and if caused by the "interference" of rays?

Yours respectfully,  
(Signed) M. SPENCE.

### Aurora Borealis.

A FINE display of aurora was observed here on the evening of January 4. A faint northern glow was seen at 8.30, which quickly grew in brightness, and at 8.45, streamers in great quantity were visible. At 9 these became tinted with glowing red on their upper portions. After exhibiting lively motions for a quarter of an hour or so, the phenomenon settled down into a brilliant and steady arch of light, red on the outside and white within, resting on what appeared to be a bank of dark cloud. By eye estimate this arch would extend about 90 along the horizon, its apex over the north-north-west from 25° to 30° in height. The glow was still visible at 10 p.m., though considerably diminished in intensity. During the whole of the day a dry and frosty north-west wind prevailed, and the temperature at 10 p.m. was 28°.

J. LOVELL.

Driffield, East Yorkshire, January 5.

### A Double Moon.

ON December 22, a well-defined double moon was seen 7m. before sunrise, which is here now at about 7. The fictitious moon was as a disk of white glass, through which the under-lapping part of the true moon could be seen. Atmospheric conditions being similar next morning, I watched for a repetition of the phenomenon, but after some abortive efforts, consisting of repeated, momentary, ill-defined projections of the moon's shape at a distance of three times the space occupied by her diameter, it was finally "given up."

ROSE MARY CRAWSHAY.

Mentone, Hotel du Louvre, December 30, 1891.

## ON THE RELATION OF NATURAL SCIENCE TO ART.<sup>1</sup>

### II.

THERE is yet another direction in which art owes instructive disclosures to the progress of photography. In the year 1836, the brothers William and Edward Weber represented, in their celebrated work on the "Mechanism of the Human Locomotive Apparatus," a person in the act of walking, in those attitudes which, according to theoretical calculation, must occur successively during one step. Thence a strange fact became apparent. At the beginning and end of each step, while the body rests for a short time on both feet, the pictures agree perfectly with the ordinary way in which painters have been accustomed to represent walking persons. But during the middle of the step, while one foot is swinging past the other, the effect is highly eccentric, not to say ludicrous; the individual appears to be stumbling over his own feet like a tipsy fiddler, and nobody had ever been seen walking in such a way. On the last page of their book, the brothers Weber propose to test the correctness of their diagrammatic figures by the aid of Stamper and Plateau's stroboscopic disks, in the shape of Horner's Dædaleum,<sup>2</sup> which has, strange to say, returned to us from America as a new invention, under the name of "zoëtrope" or even "vivantescope"; but whether the proposal was carried out or not, does not appear.

However, William Weber lived to see his assertions thoroughly justified almost half a century later by instantaneous photography. It was first put into practice in 1872 by Mr. Eadweard Muybridge at the suggestion of Mr. Stanford, in order to fix the consecutive attitudes of horses in their different paces. The result was the same as in Weber's diagrammatic figures; pictures were obtained which nobody could believe to have seen in reality. On photographs of street life and processions the camera frequently surprised people in attitudes quite as odd as those attributed to them by the brothers Weber on theoretical grounds. The same is the case with the remarkable series of photographs of a flying bird during one beat of its wings, obtained by M. Marey with his photographic gun.

The explanation is known to be as follows: An object in motion, the speed of which varies periodically, leaves a deeper and more lasting impression on our mind in those positions which it occupies longest, while the impression is fainter and more fleeting in those through which it passes quickly. Apart from all knowledge of this law, a painter would never represent a Dutch clock in a cottage with the pendulum at the perpendicular, as every spectator would inquire why the clock had been

stopped. The pendulum, having swung in one direction, necessarily stops for a moment while preparing to return in the other, and consequently its diverging position is more vividly stamped on our minds than those during which it passes through its position of rest with a maximum of speed. Precisely the same thing occurs with the alternately swinging legs of a man during the act of walking; the body remains longest in the position in which both feet support it, and shortest in that during which one foot swings past the other. We therefore receive scarcely any impression from the latter series of attitudes. We imagine a walking person, and painters accordingly represent him, in the interval between two steps, with both feet touching the ground.

In the case of a running horse, however, particular circumstances intervene. However rapid the succession of instantaneous photographs, we never obtain the usual image of a racing horse such as it appears in large numbers in the print-shops at the racing season, and such as we suppose we actually see in reality. It is different in the case of man; there among pictures obtained methodically or by chance, which have, so to speak, never been perceived by the naked eye, some will always occur which agree with the usual aspect of a walking person. The difference consists in this, that in a racing horse the interval of time, during which the fore-legs remain in complete extension, does not coincide with that during which the hind-legs are fully extended. Both these positions prevailing in our memory, they are subsequently blended into the traditional picture of a racehorse, whereas instantaneous photography fixes them successively. Consequently the traditional picture is wrong, and exhibits the horse in a position through which it does not even transitorily pass.

In the year 1882, an illustrated American paper brought out a picture of a steeplechase, in which all the horses are copied from Muybridge's photographs, in attitudes only visible to a rapid plate. This ingenious sketch was communicated to us by Prof. Eder in Vienna, in a pamphlet on instantaneous photography, and a stranger spectacle cannot well be imagined. The correctness of these apparently wrong pictures can, however, be proved by realizing the idea originally suggested by the brothers Weber, and integrating into a general impression the periodical motion which has been resolved, as it were, into differential pictures. This is done by gazing in the dædaleum at a series of photographs taken at sufficiently brief intervals from an object in periodical motion, or illuminating or projecting it momentarily during its rapid flight past the eye. The latter method has been put into practice by Mr. Muybridge himself in his "zoopraxiscope," and with us in the electric stroboscope by Mr. Ottomar Anschütz, a most skilful handler of instantaneous photography. In both instruments we see men and horses reduced to their natural mode of walking, running, or jumping—with one exception. The speed with which the slits of the dædaleum pass before the eye, or the period during which each picture is illuminated, being exactly the same for the whole series, the general effect produced is somewhat different from what it would be in real life. On the whole, however, the position in which both feet are touching the ground, prevails, because the motion of the legs slackens when approaching this position, so that the pictures follow each other more closely and almost coincide.

The series of instantaneous photographs taken by Mr. Muybridge and Mr. Anschütz from an athlete, during the performance of a muscular effort, are an inexhaustible source of instruction to students of the nude. Mr. Anschütz's stroboscope exhibits a stone- and spear-thrower in all the different stages of their violent action: their muscles are seen to swell and slacken, until finally the missile is represented after its discharge, as it cannot move any faster than the hand in the act of hurling it.

<sup>1</sup> An Address delivered by E. du Bois-Reymond, M.D., F.R.S., at the annual meeting of the Royal Academy of Sciences of Berlin in commemoration of Leibnitz, on July 3, 1890. Translated by his daughter. This Address was first printed in the weekly reports (*Sitzungsberichte*) of the Berlin Academy, then in Dr. Rodenberg's *Deutsche Rundschau*, and lastly it was published as a separate pamphlet by Veit and Co., at Leipzig, 1891. Continued from p. 204.

<sup>2</sup> *Philosophical Magazine*, January 1834, 3rd Series, vol. ii., p. 36.

Animal painters will find equally useful the instantaneous photographs which Mr. Muybridge and Mr. Anschütz have obtained from domestic and wild animals.

Even on breakers in a stormy sea the camera has been employed with surprising success. In making use of these photographs, painters should, however, remember that the human eye cannot see the waves as a rapid plate does, and beware of producing a picture which in certain respects would be quite as incorrect as the clock which appears to have been stopped, or the man stumbling over his own feet.

Finally, the traditional representation of lightning in the shape of a fiery zigzag has been recently proved by Mr. Shelford Bidwell, on the evidence of two hundred instantaneous photographs, to be just as wrong as the traditional picture of a racing horse. Mr. Eric Stuart Bruce endeavours to vindicate the zigzag by taking it for a reflection on cumulus clouds;<sup>1</sup> it is, however, difficult to understand how its sharp angles can be accounted for in this way.

Prof. von Brücke has devoted a special essay to the rules for the artistic rendering of motion, which, together with the laws on the combination of colours, have at all times been unconsciously followed by the great masters.

A cultivated and artistically gifted eye, supported by sufficient technical knowledge, was always able to compose genuine works of art in photography, as Mrs. Cameron long ago proved. In our days, Dr. Vianna de Lima has shown how this branch of art has been advanced and extended by instantaneous photography. It contributes a solution to Conti's question in Lessing's "Emilia Galotti"—whether Raphael, had he been born without hands, would not the less have been the greatest of painters. The photographic plate has been described as the true retina of the philosopher; and one might add, of the artist, if it were not unluckily almost colour-blind. Unfortunately, theoretical reasons which experience will hardly contradict render it highly improbable that the expectations still entertained by artists and the general public, with regard to photography in natural colours, will ever be realized.

Whether photography does not act unfavourably on the reproductive arts, such as engraving, lithography, and woodcutting, by taking their place to an increasing extent, remains to be proved. Its fidelity is certainly such as, in a certain sense, to lower the value of the original drawings of old masters, by making them common property. An exhibition, arranged by one of our art-dealers several years ago, of the best engravings of the "Madonna della Sedia," together with a photograph from the original, first opened our eyes to the extent to which each master has embodied in his copy his own individual conception. But even were photography to cause such a retrogression in the reproductive arts, of what importance would that be, compared to the immeasurable services which, as a means of reproduction itself, it renders art, by disseminating the knowledge and enjoyment of artistic work of all kinds and periods? No one can fully estimate and appreciate what it has done to beautify and enrich our life, whose memory does not reach back into those, as it were, prehistoric times, "when man did not yet travel by steam, write and speak by lightning, and paint with the sunbeam."

Is it credible, after all this, that there can be any need of mentioning the benefits derived by art from the study of anatomy? Has not the "Gladiator" of the Palazzo Borghese given rise to the conjecture that there were anatomical mysteries among the Greek artists, as the only means by which they could have obtained such complete mastery of the nude? Was it not through incessant anatomical studies that Michael Angelo acquired the knowledge necessary for the unprecedented boldness of his attitudes and foreshortenings, which are still a

source of admiration to anatomists such as Prof. Henke and Prof. von Brücke? Has not provision been made by all Governments that methodically encourage art, to afford to students an opportunity of training the eye on the dead subject to note what they will have to distinguish under the living skin? Have not three successive teachers, who afterwards became members of this Academy, been intrusted with this important duty in Berlin? Finally, do we not possess excellent compendiums of anatomy specially adapted to the use of artists?

And yet the most renowned English art critic of the day, who in his country enjoys the reputation and veneration of a Lessing, and who lays down the law with even more assurance—Mr. John Ruskin—explicitly forbids his pupils the study of anatomy in his lectures on "The Relation of Natural Science to Art,"<sup>2</sup> given before the University of Oxford. Even in the preface he deplores its pernicious influence on Mantegna and Dürer, as contrasted with Botticelli and Holbein, who kept free from it. "The habit of contemplating the anatomical structure of the human form," he continues, "is not only a hindrance but a degradation, and has been essentially destructive to every school of art in which it has been practised." According to him, it misleads painters, as for instance Dürer, to see and represent nothing in the human face but the skull. The artist should "take every sort of view of animals, in fact, except one—the butcher's view. He is never to think of them as bones and meat."

It would be waste of time and trouble to refute this false doctrine, and to set forth what an indispensable aid anatomy gives to artists, without which they are left to grope in the dark. It is all very well to trust one's own eyes, but it is better still to know, for instance, how the male and female skeleton differ; why the kneecap follows the direction of the foot during extension, and not during flexion of the leg; why the profile of the upper arm during supination of the hand differs from that during pronation; or how the folds and wrinkles of the face correspond to the muscles beneath. Campe's facial angle, though superseded for higher purposes by Prof. Virchow's basal angle, still reveals a world of information. It is hardly conceivable how, without knowledge of the skull, a forehead can be correctly modelled, or the shape of a forehead such as that of the "Jupiter of Otricoli" or the "Hermes" be rightly understood. Of course fanciful exaggeration of anatomical forms may lead to abuse, as is frequently the case with Michael Angelo's successors; however, there is no better remedy against the Michael Angelesque manner than earnest study of the real. Finally, a superficial knowledge of comparative anatomy helps artists to avoid such errors as an illustrious master once fell into, who gave the hind-leg of a horse one joint too many; or such as amuses naturalists in the crocodile of the Fontaine Cuvier near the Jardin des Plantes, which turns its stiff neck so far back that the snout almost touches the flank.

We are, however, less surprised at Mr. Ruskin's opinions, on learning that he similarly prohibits the study of the nude. It is to be confined to those parts of the body which health, custom, and decency permit to be left uncovered, a restriction which certainly renders anatomical studies somewhat superfluous. It is satisfactory to think that decency, custom, and health allowed the ancient Greeks more liberty in this respect. Fortunately, the English department of the Berlin International Exhibition four years ago has convinced us that Mr. Ruskin's dangerous paradoxes do not yet generally prevail, and that we are free to forget them in our admiration of Mr. Alma Tadema's and Mr. Herkmer's paintings. Nor could Mr. Walter Crane's charming illustrations, the

<sup>1</sup> "The Eagle's Nest: Ten Lectures on the Relation of Natural Science to Art," 1887.

delight of our nurseries, have been produced without disregard of Mr. Ruskin's preposterous doctrine.

In the same lecture Mr. Ruskin opposes with the utmost vehemence the theory of evolution and natural selection, and the aesthetic rule founded on it, according to which vertebrate animals should not be represented with more than four legs. "Can any law be conceived," he says, "more arbitrary, or more apparently causeless? What strongly planted three-legged animals there might have been! what systematically radiant five-legged ones! what volatile six-winged ones! what circumspect seven-headed ones! Had Darwinism been true, we should long ago have split our heads in two with foolish thinking, or thrust out, from above our covetous hearts, a hundred desirous arms and clutching hands, and changed ourselves into Briarean Cephalopoda."

Obviously, this false prophet has no notion of what in morphology is called a type. Can it be necessary to remind a countryman of Sir Richard Owen and Prof. Huxley that the body of every vertebrate animal is based on a vertebral column, from which it derives its name, expanding at one end into a skull, reduced to a tail at the other, and surrounded before and behind by two bony girdles, the pectoral and the pelvic arches, from which depend the fore and hind limbs with their typical joints? The very fact that palæontology has never known any form of vertebrate animal to depart from this type is in itself a striking argument in favour of the doctrine of evolution, and against the assumption of separate acts of creation; there being no reason why a free creative Power should have thus restricted itself. So little will Nature deviate from the type once given, that even deformities are traced back to it by teratology. They are not really monstrosities; not even those with a single eye in the middle of the forehead, which Prof. Exner takes to be prototypes of the Cyclops, Flaxman being certainly mistaken in representing Polyphemus with three eyes—two normal ones which are blind, and a third in the forehead. Real monstrosities are those winged shapes of Eastern origin, invented by a riotous fancy while art was in its childhood: the bulls of Nimród, the Harpies, Pegasus, the Sphinx, the griffin, Artemis, Psyche, Notos of the Tower of Winds, the goddesses of Victory, and the angels of Semitic-Christian origin. A third pair of extremities, (Ezekiel even admits a fourth) is not only contrary to the type, but also irrational in a mechanical sense, there being no muscles to govern them. In the "Fight with the Dragon," Schiller has happily avoided giving his monster the usual pair of wings; and in Retzsch's illustrations its shape agrees so far with comparative anatomy as to recall a Plesiosaurus or Zeuglodon returned to life and changed into a land animal; indeed, the resemblance between those animals and the mythical dragon has led to the question whether the first human beings might not have actually gazed upon the last specimens of those extinct animal races.

An abomination closely related to the winged beasts are the Centaurs, with two thoracic and abdominal cavities, and a double set of viscera; the Cerberus and Hydra, with several heads on as many necks; and the warm-blooded Hippocamps and Tritons, whose bodies, destitute of hind limbs, end in cold-blooded fish—an anomaly which already shocked Horace. If they had at least a horizontal tail fin, they might pass for a kind of whale. The cloven-footed Faun is less intolerable; from him our Satan inherited his horns, pointed ears, and hoofs, on account of which Cuvier, in Franz von Kobell's witty apologue, ridicules him as an inoffensive vegetable feeder. The heraldic animals, such as the double eagle and the unicorn, have no artistic pretensions, and their historical origin entitles them to an indulgence they would otherwise not deserve.

It is a remarkable instance of the flexibility of our sense of beauty that, though saturated with morphological principles, our eye is no longer offended by some of these monstrosities, such as the winged Nike and the angels; and

it would perhaps be pedantic, certainly ineffectual, to entirely condemn these traditional and more or less symbolical figures, though in fact the greatest masters of the best epochs have made very slight use of them. There are, however, limits to our toleration. Giants, as they occur in our Gigantomachia, with thighs turning half-way down into serpents, which consequently rest, not upon two legs, but upon two vertebral columns ending in heads and endowed with special brains, spinal cords, hearts, and intestinal canals, special lungs, kidneys, and sense-organs—these are, and always will be, the abhorrence of every morphologically trained eye. They prove that, if the sculptors of Pergamon surpassed their predecessors of the Periclean era in technical skill, they were certainly second to them in artistic refinement. Perhaps they should be excused on the plea that tradition bound them to represent the giants with serpent legs. The Hippocamps and Tritons, with horses' legs and fish-tails, which disfigure our Schlossbrücke, date from a period in which classical taste still reigned supreme, and morphological views were still less widely diffused than at present. Let us therefore pardon Schinkel for designing or at least sanctioning them, as well as the winged horse and griffin on the roof of the Schauspielhaus, for which he must also be held responsible. But our indignation is justly aroused when a celebrated modern painter depicts with crude realism such misshapen male and female monsters wallowing on rocks, or splashing about in the sea, their bodies ending in fat shiny salmon, with the seam between the human skin and the scaly cover scantily disguised. Such ultramarine marvels are worshipped by the crowd as the creations of genius; then what a genius Höllen-Breughel must have been!

Curiously enough, the inhabitants of the caves of Périgord, the contemporaries of the mammoth and musk-ox in France, and the bushmen whose paintings were discovered by Prof. Fritsch, only represented as faithfully as possible such animals with which they were familiar; whereas the Aztecs, a people of comparatively high civilization, indulged in fancies of more than Eastern hideousness. It would almost appear as if bad taste were associated with a middle stage of culture.

With regard to the teaching of anatomy in schools of art, the above proves that it should not be confined to human osteology, myology, and the doctrine of locomotion alone, but that it should also endeavour—and the task is not difficult—to familiarize the student with the fundamental principles of vertebral morphology.

Botanists should in their turn point out such violations of the laws of the metamorphosis of plants as must, no doubt, frequently strike them in the acanthus arabesques, palmettos, rosettes, and scrolls, handed down to us from the ancients. From obvious reasons, however, these cannot affect them as painfully as malformations of men and animals, being in themselves repulsive to natural feelings, would the comparative anatomist. Moreover, a beneficial revolution has recently taken place in floral ornament. The displacement of Gothic art by the antique during the Renaissance had led to a dearth of ideas in decorative art. The rich fancy and naïve observation of nature, displayed upon the capitals of many a cloister, had gradually given way to a fixed conventionalism, no longer founded on reality. Rauch, at Carrara, in search of a model for the eagles on his monuments, was the first to turn to a golden eagle, accidentally captured on the spot, instead of to one of the statues of Jupiter. It was then that, towards the middle of the century, decorative art began to shake off its fetters, and, combining truthfulness with beauty, returned to the study and artistic reproduction of the living plants with which we are surrounded. In this respect the Japanese had long ago adopted a better course, and to them we have since become indebted for many suggestions. Thus highly welcome additions were

made to the decoration of our homes, and the ornaments of female dress.

In one direction, however, it will be observed that men of science readily dispense with a strict observation of the laws of nature in art, at the risk of being charged with inconsistency. In works of art, both ancient and modern, flying and soaring figures occur in thousands. These, no doubt, sin against the omnipotent and deeply felt laws of gravity quite as much as the most loathsome creations of a depraved imagination against the principles of comparative anatomy, familiar only to a few adepts. Nevertheless they do not displease us. We prefer them without wings, because wings are contrary to the type, and could be of no use to them without an enormous bulk of muscle. But we do not mind the Madonna Sistina standing on clouds, and the subordinate figures kneeling on the same impossible ground. "Ezekiel's Vision" in the Palazzo Pitti is certainly less acceptable. But to quote modern examples, Flaxman's "Gods flying to the aid of the Trojans," or Cornelius's Apocalyptic riders, and Ary Scheffer's divine Francesca di Rimini, with which Doré had to enter into hopeless competition, are not the less enjoyable because they are physically impossible. We do not even object to Luini's representing the corpse of St. Catharine carried through the air by angels, or to that of Sarpedon, in Flaxman's drawing, by Sleep and Death.

In an interesting lecture on the "Physiology of Flying and Soaring in the Fine Arts," Prof. Exner endeavours to explain why illustrations of men and animals in this condition, though impossible and never visible in real life, strike us as familiar and natural. I do not profess to agree entirely with the solution which he appears to prefer. His idea is, that our sensations in swimming, and the position in which we see persons above us in the water when diving, are similar to what we would experience in flying. Considering what a short time the art of swimming has been generally practised by modern society, especially by ladies, who nevertheless appreciate flying figures just the same, doubts arise as to the correctness of Prof. Exner's explanation. To attribute the feeling to atavism in a Darwinian sense, dating from a fish-period in the development of man, seems rather far-fetched. And do not the sensations and aspect of a skater come much nearer to flying or soaring than those of a swimmer?

Another remark of Prof. Exner, which had also occurred to me, appears more acceptable. It is, that under especially favourable bodily conditions we experience in our dreams the delicious illusion of flying. For

"in each soul is born the pleasure  
Of yearning onward, upward, and away,  
When o'er our heads, lost in the vaulted azure,  
The lark sends down his flickering lay,  
When over crags and piny highlands  
The poising eagle slowly soars,  
And over plains and lakes and islands  
The crane sails by to other shores."<sup>1</sup>

Who would not long, like Faust, to soar out and away towards the setting sun, and to see the silent world bathed in the evening rays of eternal light far beneath his feet? And when we long for anything, we love to hear of it, and to see it brought before us in image. Our desire to rise into the ether, and our pleasure in "Ascensions" and similar representations, are further enhanced by the ancient belief of mankind in the existence of celestial habitations for the blessed beyond the starry vault; a belief which Giordano Bruno put an end to, though not so thoroughly but that we are constantly forgetting how badly we should fare, were we actually to ascend into those vast, airless, icy regions, which even the swiftest eagle would take years to traverse before alighting on some probably uninhabitable sphere.

We are now inclined to waive the question, and to

<sup>1</sup> Translation of Goethe's "Faust," by Bayard Taylor.

ask: What have sculpture and painting been able to do for science in return for its various services? With the exception of external work, such as the representing of natural objects, not much else than the results obtained by painters as to the composition and combination of colours, which, however, have not exercised as strong an influence on chromatics as music on acoustics. It is known that the Greeks possessed a canon of the proportions of the human body, attributed to Polykletes, which, as Prof. Merkel recently objected, unluckily only applied to the full-grown frame, to the detriment of many ancient works of art. The blank was not systematically filled up till the time of Gottfried Schadow. This canon has since become the basis of a most promising branch of anthropology—anthropometry in its application to the human races.

If the definition of art were stretched so far as to include the power of thinking and conceiving artistically, then indeed it would be easy enough to find relations and transitions between artists and philosophers, though, as we remarked at the beginning, their paths diverge so completely. But it is not so certain that natural science would necessarily be benefited by an artistic conception of its problems. The aberration of science at the beginning of this century known as German physiophilosophy owed its origin quite as much to aesthetics as to metaphysics, and the same erroneous principles guided Goethe in his scientific researches. The artistic conception of natural problems is in so far defective, as it contents itself with well-rounded theoretical abstractions, instead of penetrating to the causal connection of events, to the limits of our understanding. It may suffice in cases where analogies are to be recognized by a plastic imagination between certain organic forms, such as the structure of plants or vertebrate animals; but it fails altogether in subjects such as the theory of colours, because it stops short at the study of what are supposed to be primordial phenomena, instead of analyzing them mathematically and physically. Prof. von Brücke subsequently, by the aid of the undulatory theory, traced to their physical causes the colours of opaques on which Goethe founded his theory of colours, and which to this day have tended rather to darken than to enlighten certain German intellects. The difference between artistic and scientific treatment becomes very evident in this example.

Nevertheless, it cannot be denied that artistic feeling may be useful to scientific men. There is an aesthetic aspect of experiment which strives to impart to it what we have termed mechanical beauty; and no experimenter will regret having responded to its demands as far as was in his power. Moreover, the transition from a literary to a scientific epoch in the intellectual development of nations is accompanied by a tendency to brilliant delineation of natural phenomena, arising from the double influence of the setting and the dawning genius. Instances thereof are Buffon and Bernardin de Saint-Pierre in France, and Alexander von Humboldt in Germany, who, to his extreme old age, remained faithful to this tendency. In the course of time, this somewhat incongruous mixture of styles splits into two different manners. Popular teaching preserves its ornamental character, while the results of scientific research only claim that kind of beauty which in literature corresponds to mechanical beauty. In this sense, as I long ago ventured to indicate here on a similar occasion, a strictly scientific paper may, in tasteful hands, be made as finished a piece of writing as a work of fiction. To strive after such perfection will always repay the trouble to men of science; for it is the best means of testing whether a chain of reasoning, embracing a series of observations and conclusions, is faultlessly complete.

And this kind of beauty, which often graces, unconsciously and unsought for, the utterances of genius, will no doubt be also found to adorn Leibnitz's writings.

CHRONOPHOTOGRAPHY, OR PHOTOGRAPHY  
AS APPLIED TO MOVING OBJECTS.<sup>1</sup>

THIS subject forms the basis of a very interesting article, in the *Revue Générale des Sciences*, by Prof. Marey, who explains a new method for the analysis of the movements of various bodies that are under consideration, more especially in biological than in physical science. Our readers may remember a book that appeared in the year 1882, entitled "The Horse in Motion," published under the auspices of Leland Stanford. Mr. Stanford, wishing to study the relative positions of the feet of horses in rapid motion, employed Mr. Muybridge, who was then noted as a very skilful photographer, to carry out a series of experiments. The success which rewarded their endeavours revealed so much that seemed of importance, that he determined to make a complete study of the subject, and with this intention employed Dr. J. D. B. Stillman, to whom he intrusted the undertaking.

The method the last mentioned adopted was very similar to that employed later by Mr. Muybridge, the differences being that he only made use of one series of cameras, and that the plates were exposed by the breaking of threads by the moving object. The revolving disk was also in vogue then, for taking movements of running dogs, flights of birds, &c., only it was not used to obtain the movements of the horse, as it was found extremely difficult to set the apparatus in motion at the exact moment required, and to regulate it to the speed of the horse.

It is important, next, to refer to the results obtained by Mr. Muybridge in his later experiments, carried out at the University of Pennsylvania, which were published in a large book containing all the series of photographs. The following is a brief account of the method he used.

It consisted in the employment of three batteries, each containing twelve cameras. The object of working with three batteries was to enable him to obtain photographs from three points of view simultaneously, and the manner in which he arranged them was as follows. One battery was set parallel to the track along which the object to be photographed moved, so that its image would be formed on each plate successively as it passed before the lenses; and since the distance between the object and each camera was constant, only one focus was required. Placed at right angles to this track, and directed up and down it, were fixed respectively the two other batteries, and the cameras in these were so adjusted as to have in their field of view the same series of positions as seen in the first battery, only of course from two different stand-points; but since in this case the distance between the object and the cameras was always varying, each of the latter had to be specially adjusted for its own focus.

The instantaneous shutters of all the cameras were connected by wires to a set of twelve metal studs situated on the circumference of a disk, each stud being fastened to a set of three wires, each of which comes from the first camera in each battery, the second set from the second cameras, and so on.

A second disk, placed close by, and carrying a brush, was made to rotate, the brush coming in contact with each of the studs in turn. By this means, a series of currents was sent to these groups of three cameras intermittently; and, as each contact was made, three shutters were simultaneously released—one in each of the series—giving a group of three synchronous pictures of the object that was moving on the track, showing the fore, hind, and lateral views.

One of the first attempts of Prof. Marey consisted in placing on each foot of the moving animal elastic cushions, which were connected with a chronograph by

means of flexible tubes. As each foot came in contact with the ground, a record of the impact was obtained, from which interesting results were deduced relating to the peculiarities of the succession of steps, and the time-intervals separating them.

Having referred above to the earlier experiments, we will now mention the very recent work carried out by him. The method that he here adopts differs considerably from his first endeavour, and also from that employed by Muybridge and Stillman. Instead of using many cameras, and therefore many plates, he works with one camera and one plate, and it is on this plate that he produces his series of photographs. The objects that he wishes to study move in front of a dark background, which is situated directly opposite the camera. Fitted to the camera is a large disk with openings in it, and which is capable of quick or slow rotation in a vertical plane.

During the passage of one of these openings before the lens, the moving object has its image cast on the photographic plate, and is there recorded: as soon as the aperture has passed, no light can fall on the plate until the next opening comes opposite. As soon as this arrives, another picture is taken in the same way, but, during the interval that has just elapsed, the object, having changed its place, forms its image naturally on another part of the plate. By continuing this process, one can easily see that, on the plate being developed, a series of successive images will be seen extending from one side to the other.

With a very slow-moving object, this method cannot be applied so well, unless an intermittent rotation be given to the disk, as we should have a series of overlapping images quite undistinguishable from one another. The following illustration (Fig. 1) is an example of a



FIG. 1.—Arab horse at full gallop.

picture obtained by using a continuously revolving disk. Between each exposure it will be seen that the horse has not even travelled its own length, but only a little over half, so that the mingling of all the images results in a picture that is useless for purposes of study. The question which was raised from such results as shown in the above figure may be formulated thus: How is it possible to reduce the surface of the object, and yet be able to record the movements of its principal members photographically? The following very artful device, which is shown in the next illustration (Fig. 2), exemplifies the manner in which Prof. Meyer solved the question. By dressing the object in black, employing a dark background, and placing on the members, the movements of which he wished to investigate, white lines and spots, he was able to increase the number of exposures per second without introducing overlapping, and to record the successive positions taken up by them.

We must mention here that the experiments were only carried out with a man as object; if a horse had been taken, it would have been necessary to have dressed it in black, and to have put the distinguishing marks on either one of the fore or hind legs, and not on both at once; otherwise there would have been two complete series of images recorded on one plate at the same time, and overlapping each other.

<sup>1</sup> We are obliged to the editor of the *Revue Générale des Sciences* for permission to use the illustrations reproduced in this article.

In another illustration we have an interesting set of attitudes assumed by a running man dressed in this costume



FIG. 2.—Man dressed in black, and consequently invisible when passing before a dark background. The white lines which are shown on his arms, legs, and on the sole of one foot are the only parts the successive phases of which can be recorded.

(Fig. 3). The lines in the figure indicate the sequence of positions in which the above-mentioned distinguishing

being photographed in a given time is very largely increased, while the overlapping is only slightly apparent. Another case is that shown in Fig. 4, which represents a man jumping. The several phases of movement are here also well discernible, and the images were recorded at the rate of twenty-five per second.

Although the method employed above suited admirably for such purposes as we have mentioned, yet Prof. Marey found that he could not use it without modification for all the cases to which he wished to apply it. The apparatus which he then constructed, and of which a complete detailed account is given in his article, is shown in Fig. 5, and

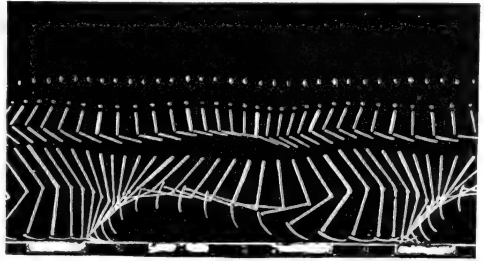

FIG. 3.—Images of a runner, showing the white marks which represent the attitudes of the principal members. Chronophotography on a fixed plate.

differs in many particulars from the former one, the chief characteristic about it being that films are employed which are capable of rapid lateral movement. By means of this moving film it is possible to obtain, in a very short space of time, a large number of separate pictures, for, during each exposure, a new part of the film is brought opposite the lens of the camera, held there, and then slipped along. The apparatus itself is of a most ingenious construction, and the three most important parts consist of a driver, a clamper, and an elastic arm.

In the figure, L represents the driver, and it is due to its action that the motion of the paper is produced; it consists of a wooden cylinder, the surface of which is covered with india-rubber, and round which the band of

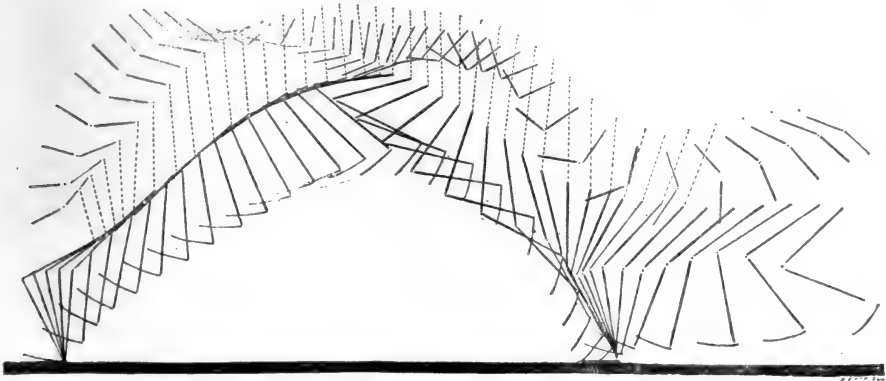

FIG. 4.—Analysis of the phases of a running high jump. Taken on a fixed plate (twenty-five images per second).

marks are found at each exposure; and the resulting diagram also shows that the number of images capable of

paper passes when made to travel from one bobbin to the other.

In the case of the clammer, marked *C'* in the drawing, its action is to press the paper against the side of the chamber during each exposure, and this is carried out by means of a series of cams placed on a small circular horizontal disk (marked *C*). It might be supposed that, with very short exposures obtained by means of a very rapid shutter, the clammer would be found quite unnecessary, as the horizontal distance traversed by the band of paper during an exposure would be practically *nil*, or at any rate small enough to produce no visible effect on the

lodoce, . . . passing on to scorpions and spiders, and then to shrimps, lobsters, . . ."

Although, at the first glance, one cannot quite see how Muybridge's principle, or, at any rate, a slight change of it, could be applied to interpret the gait of the centipede, yet in Prof. Marey's instrument Prof. Lankester will, we hope, find just the kind of apparatus to carry out the various suggestions to which he referred. In fact, the instrument has already been employed in producing pictures representing aquatic locomotion, and the follow-

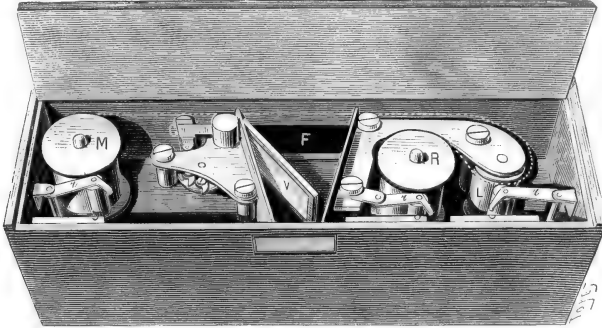

FIG. 5.—The chamber in which the images are formed, with the lid raised. *M* and *R* are the drums on which the films are rolled off and on respectively; *r*, *r*, *r*, small rollers pressing the film on the cylinders; *L*, the driver, with its pressing cylinder; *F*, the aperture for the admission of the image; *v*, ground glass with hinged motion. The dotted line indicates the path of the band of film; *c'* and *c*, the clammer and its cam, which produces the intermittent action of this band.

picture produced; but this is not the case, for Prof. Marey says that by experience the only good images obtainable were made with the use of the stop.

Owing to the quickness of the action of the driver, and the instantaneous blow given by the clammer to the paper at each exposure, an elastic arm is made to come into play to relieve the paper of any strain or force to which it may be subjected.

Many readers may remember the very interesting

ing illustration (Fig. 6) shows a Medusa swimming, while Fig. 7 shows the phases of movement that a star-fish undergoes in order to turn itself over.

The interesting point is displayed in the last four pictures of the series. Counting from the bottom, No. 5 shows the position just before one of his "rays" leaves the ground and just when he begins to grip it with the other two; having this grip, he is able to dispense with the use of the other ray, and so raises the other three as



FIG. 6.—Medusa swimming horizontally, whilst moving away from the apparatus (negative).

article in a former number of *NATURE* (vol. xl. p. 78), written by Prof. Ray Lankester, relating to the Muybridge photographs. Towards the end he says: "For my own part I should greatly like to apply Mr. Muybridge's cameras, or a similar set of batteries, to the investigation of a phenomenon more puzzling even than that of 'the galloping horse.' I allude to the problem of 'the running centipede.'" He then goes on to say: "I am anxious to compare with these movements the rapid rhythmical actions of the parapodia of such *Chaetopods* as *Phyl-*

shown in No. 6. No. 7 illustrates the position of unstable equilibrium as obtained by means of the preceding movements, while the last one exemplifies stable equilibrium again.

The time occupied in the above evolutions is not so short as may be supposed, but lasts sometimes from ten to twenty minutes, the intervals in time between two of the above pictures being about two minutes.

The movements of the eel have also been studied in this way, and the series of movements represented in



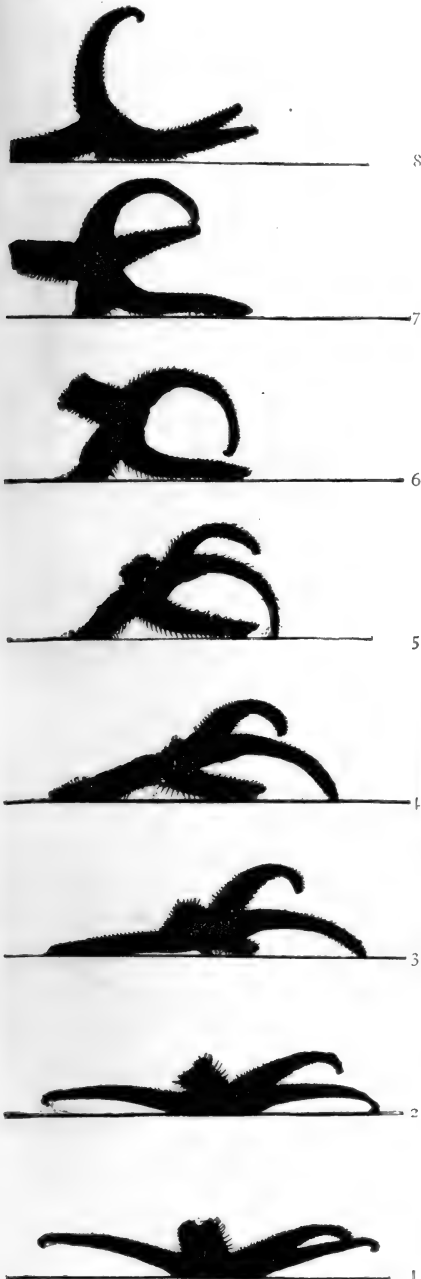

FIG. 7.—Series of phases performed by a star-fish in turning itself over.

Fig. 8, illustrating an eel swimming horizontally, brings out clearly the wave produced by the effect of the un-

dulatory movement of the body, propagating from the head to the tail.

In observing the movements of many other different species of serpents, both in and out of water, Prof. Marey says: "La reptation des uns et la natation des autres présentent de grandes analogies avec la natation de l'anguille, mais nous n'y avons pas trouvé la même régularité des mouvements."

But in the study of the movements of objects as small

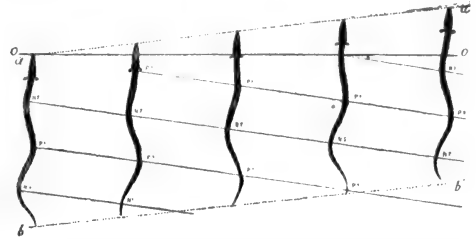

FIG. 8.—Eel swimming in a horiz ntal plane. The horizontal line *oo* shows plainly the inclination of those lines which join the crests and troughs of the waves formed by the body, so that the velocity of progression of the animal is expressed by the inclination of the line *oo*.

as these, Prof. Marey does not here conclude his observations, but has constructed a special piece of apparatus, as shown in Fig. 9, for recording the movements of microscopical objects. The general working of this apparatus can be seen at a glance. C is the large condenser which concentrates all the light from some artificial source on to the small holder *φ*, in which the object is placed. The micrometer objective marked *o*,

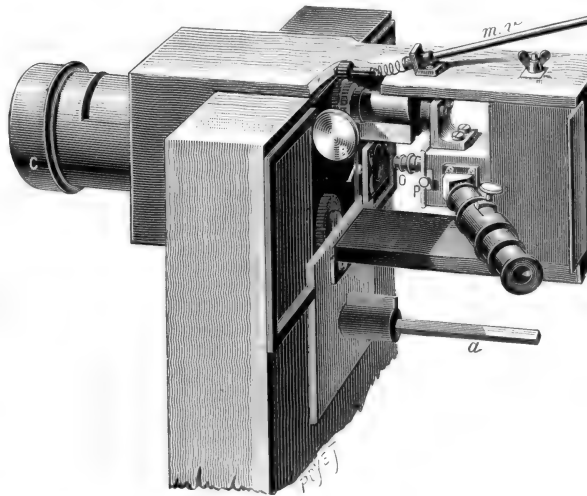

FIG. 9.—Special piece of apparatus for studying the movements of microscopical objects.

is placed on the other side of this holder, but in the axis of the condenser. The micrometer head *B* regulates the distance of *φ* from *o*, and can be moved either by the rod *mv*, or by its milled head. An important adjunct to the instrument is the microscope that is placed obliquely at the side of the camera; by its means, and by that of a small prism that can be placed in the axis of the light by simply pulling or pushing the knob *P*, the object about

to be photographed can be observed just before exposure, which insures the centrality of its image on the sensitive film.

The extension of this branch of chronophotography, if taken up and developed, may be of great use to medical science, for many occurrences happen where such an apparatus as the above would be invaluable. One of the examples done by this method is shown in Fig. 10,

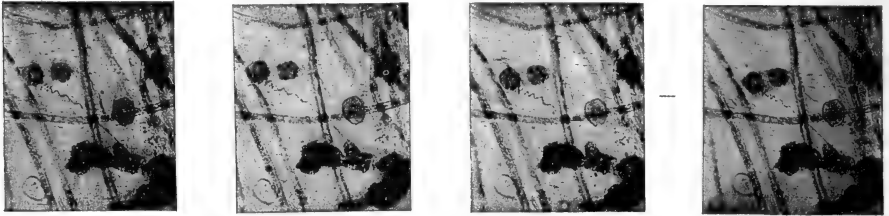

FIG. 10.—Showing the movements of Vorticellæ. The phases of movements must be read from left to right.

and illustrates the movements of Vorticellæ, which retract their stalks in spiral fashion. Many other proposals, not yet carried out, are mentioned by Prof. Marey, and include the production of photographs showing the movements of blood corpuscles in the capillary tubes, the intimate actions of the contraction of the fibre of the muscles, and the waves which pervade them.

Prof. Marey also applies chronophotography to move-

while on its upward bound the decrease is also apparent, perhaps not so much, on account of the ball approaching the camera.

Although we have not quite touched on all the subjects referred to in the very interesting article by Prof. Marey, yet we trust we have given the reader an idea of what kind of work has been going on in this direction, and the methods that have been adopted to produce such

good results. The branch that we look forward to being greatly extended is that in which the microscope takes the prominent part. W.

#### SIR GEORGE BIDDELL AIRY.

WE greatly regret to have to record the death of Sir George Biddell Airy, whose name has been familiar to the scientific students of more than one generation. He died on Saturday evening last, in his ninety-first year. In the summer he received by a fall an injury which rendered a surgical operation necessary. Although at the time this seemed to be successful, he never really recovered from the shock to his system.

On October 31, 1878 (vol. xviii. p. 689), we published a portrait of Sir George Airy in our series of "Scientific Worthies," and at the same time we gave a full account of his work as a man of science. We need not now, therefore, do more than note the main facts of his career.

He was born at Alnwick, Northumberland, on July 27, 1801, and received his early education at private schools in Hereford and Colchester, and at the Manchester Grammar School. In 1819 he entered Trinity College, Cambridge, as sizar. Here he soon gave proof of a remarkable aptitude for mathematics, and in 1823 he graduated as Senior Wrangler. In the following year he was elected a Fellow of his College, and in 1826 he became Lucasian Professor of Mathematics. He was full of enthusiasm for experimental science and applied mathematics, and in 1824-25 had published papers on "The Lunar and Planetary Theories," on "The Figure of the Earth," on "The Undulatory Theory of Optics," on "The Forms of the Teeth of Wheels," and on "Escape-ments." After his appointment to the Lucasian Professorship, he continued to make important contributions to the knowledge of such subjects, devoting himself with especial ardour to the study of undulatory optics, which was at that time a new field of research.

He was elected Plumian Professor of Astronomy in 1828, a position with which was associated the directorship of the Astronomical Observatory. Here he superintended the erection of several instruments, and—in accordance with the example set by Maskelyne, and followed by Bessel and Struve—introduced a thoroughly efficient system for reducing the observations, which were printed annually. He also carried on theoretical studies. In 1831 he published in the Transactions

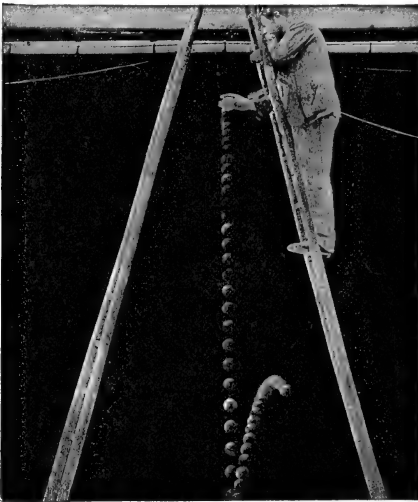

FIG. 11.—Series of positions taken up by a falling ball studied by chronophotography on a fixed plate.

ments of objects in physical as well as in biological science, but although several cases are mentioned, we will only refer here to the instance he gives of the falling ball (Fig. 11).

The intervals between each image of the ball, although different in space, are equal in time, and the illustration brings out clearly the gradual increase of the velocity;

of the Cambridge Philosophical Society an important paper on "The Inequality of Long Period in the Motions of the Earth and Venus." He wrote for the British Association in 1832 a most useful "Report on the Recent Progress of Astronomy;" and in 1833 prepared valuable papers on "The Mass of Jupiter."

When Mr. Pond, the sixth Astronomer-Royal, resigned his office in 1835, Lord Auckland, the First Lord of the Admiralty, appointed Prof. Airy to be his successor; and on January 1, 1836, the new Astronomer-Royal entered upon his duties. This was a position which accorded in all respects with Prof. Airy's wishes, and in the course of the long period during which he held it he not only maintained, but greatly increased, the fame of the Royal Observatory at Greenwich as one of the most important centres of astronomical investigation. To him the Royal Observatory owed its equipment with a series of new instruments, all of which were made from his designs, while some were of his own invention. The first of these instruments—the altazimuth—was set up in 1847, the object of the instrument being to secure that observations out of the meridian should be as accurate as observations in the meridian. The erection of this instrument led to results of much importance and interest in the observation of the moon. Other instruments erected were a new meridian-circle, the reflex-zenith-tube (put in the place of the Troughton zenith-sector), a new equatorial, an instrument planned to decide the question of the dependence of the measurable amount of sidereal aberration upon the thickness of the glass or other transparent material in the telescope, a double-image micrometer, and an orbit-sweeper, designed for the detection of comets approaching perihelion passage, the time of which cannot be exactly fixed.

The observations were made at Greenwich with perfect regularity, reduced most carefully, printed, and placed at the disposal of all who were capable of using them. We need scarcely say that they are of enormous value to astronomers.

The reduction of the Greenwich lunar and planetary observations from 1750 had been proposed to astronomers by Bessel as a task well worthy of serious effort. It was undertaken by Airy in 1833, and completed in 1848; and, as we have stated in our previous article, the reductions thus effected serve as the basis of the greater part of our present tables of the motions of the moon and the planets. He reduced various other series of observations, and by his untiring activity stimulated competent students, both in England and elsewhere, to undertake kindred work. He also gladly undertook labours which were in other ways fitted to advance astronomical science. In 1842 he went to Turin to observe the total solar eclipse, and he went for a similar purpose to Gothenburg, in Sweden, in 1851. The eclipse expedition to Spain in 1860 was organized by him, and to his care was intrusted the equipment of the British expedition for observing the transit of Venus in 1874.

Soon after his appointment to the position of Astronomer-Royal, Airy proposed to the Government that magnetical and meteorological observations should be made at Greenwich; and in 1838 his scheme was adopted, the result being that a vast number of data have since been accumulated. We need only refer to such work as his useful experiments on the deviation of the compass in iron ships; his researches on the density of the earth by observations in the Harton Colliery; and his investigations in connection with the standards, the fixing of the breadth of railways, and the introduction of a new system for the sale of gas.

His scientific eminence secured for him the position of President of the Royal Society, which he held from 1871 to 1873. He became a C.B. in 1871, and a K.C.B. in 1872. He was medallist of the French Institute, of the Royal Society (twice), of the Royal Astronomical Society

(twice), and of the Institution of Civil Engineers. The Paris Academy of Sciences made him one of its eight "Associés étrangers;" and he was an honorary member of many scientific Societies both at home and abroad.

Among the works of Sir George Airy is a little book entitled "Popular Astronomy," which has passed through many editions. He was also the author of "Treatise on Errors of Observation," "Treatise on Sound," "Treatise on Magnetism;" and of contributions to the "Penny Cyclopædia" and the "Encyclopædia Metropolitana," on such subjects as "Gravitation," "Trigonometry," "Figure of the Earth," and "Tides and Waves."

#### NOTES.

MEN of science were much pleased to learn on New Year's Day that a peerage of the United Kingdom had been conferred on Sir William Thomson. This is the second time Lord Salisbury has done honour to a President of the Royal Society, and on both occasions the wisdom of his action has been very generally appreciated. The work of men like Sir George Stokes and Sir William Thomson brings with it, of course, its own reward; but it is good for the nation that the value of their services should be officially and adequately recognized.

THE following will be the Presidents of Sections at the Edinburgh meeting of the British Association:—Mathematics and Physical Science, Prof. Arthur Schuster; Chemistry and Mineralogy, Prof. Herbert McLeod; Geology, Prof. Charles Lapworth; Geography, Prof. James Geikie; Economic Science and Statistics, the Hon. Sir C. H. Freemantle; Mechanical Science, Prof. W. C. Unwin; Biology, Prof. W. Rutherford; Anthropology, Prof. Alexander Macalister.

THE Institution of Electrical Engineers will hold the first of its meetings during the current year on Thursday, the 14th inst., when the President, Prof. W. E. Ayrton, F.R.S., will deliver his inaugural address.

At a Congregation held at Cambridge on Monday, the Duke of Devonshire was elected to the Chancellorship of the University, without opposition, in succession to his father. The formal installation will take place in the Easter term.

THE general meeting of the Association for the Improvement of Geometrical Teaching is to be held at University College, Gower Street, on Saturday, January 16. At the morning sitting (11 a.m.), the reports of the Council and the Committees will be read, and the new officers will be elected. After an adjournment at 1 p.m., members will reassemble for the afternoon sitting (2 p.m.), at which the following papers will be read:—On Laguerre's dictum concerning direction, by Prof. R. W. Genese; on the geometrical interpretation of fallacy in elimination, by Prof. R. W. Genese; on the use of Horner's method in schools, by Mr. E. M. Langley. All interested in the objects of the Association are invited to attend.

DR. RICHARD PFEIFFER, the son-in-law and assistant of Prof. Koch, and head of the Scientific Department of the new Royal Institute for Infectious Diseases, has, it is stated, discovered the influenza bacillus. Full particulars are to be published shortly. Meanwhile, according to a Reuter's telegram, it is already known that "six attempts at transplantation of the microbe have been made, and have been attended with complete success, thus proving the genuine character of the discovery."

THE International Sanitary Conference met at Venice on Tuesday. This is the sixth occasion on which the Conference has assembled. Its first meeting was held at Paris in 1851. This was followed by gatherings at Constantinople in 1860, at Vienna in 1874, at Washington in 1881, and at Rome in 1885.

THE New Year's address to the members of the Sanitary Inspectors' Association was delivered on Saturday last by Dr. B. W. Richardson, F.R.S., the President. He offered them the congratulations which, he said, they deserved to receive from everybody who was interested in the cause of sanitation on the immense advance which they, as sanitarians, had made during the past year. They occupied a better position in the public estimation than they ever did, and they stood on a firmer foundation from the circumstance that the Board of Trade had given them permission to enrol themselves as a Society limited by guarantee, which really was the same as if they were incorporated. By that progress they had gained a step which placed them in a most enviable position. It was very rarely that any Society so young as theirs received such a public recognition in so short a time. They were now practically a professional body, such as existed in the Church, the law, and physic.

THE eighth of the series of One Man Photographic Exhibitions at the Camera Club is now being held. It consists of photographs by Mr. J. Pattison Gibson. The pictures will be on view for about six weeks.

A SCIENTIFIC Commission has been appointed by the Government of Costa Rica for the investigation of various classes of phenomena in that country which have hitherto been inadequately studied. The Commission consists of Prof. H. Pittier, who acts as Director, Luis Chable, who offered his services for archaeological research, G. K. Cherrie, zoologist, and A. Tonduz, botanist.

THE organizing joint committee of the Essex County Council and the Essex Field Club have issued syllabuses of courses of instruction in several subjects, in addition to those to which we lately referred. Mr. J. T. Cunningham, of the Marine Biological Laboratory, Plymouth, is to lecture on the natural history of marketable sea-fishes, and on oysters and oyster-culture. Mr. H. N. Dickson will give three courses of lessons on elementary practical meteorology for fishermen, farmers, and sailors.

IN order to determine the local distribution and altitude of the aurora, a considerable number of observers is necessary, so distributed throughout the area covered by the observations as to secure as full information as possible with regard to the extent to which the aurora is present or absent. To aid and increase the number of observers in this field Mr. M. A. Veeder has issued some blanks and a circular, and he says:—"It is desirable to have as many observers as possible co-operate in the plan described in the accompanying circular and blanks. Auroras are likely to become more frequent during the coming year, affording a special favourable opportunity for systematic observation." It is stated in the instructions that the chief observations required are the time and zenith distance of all the prominent features. If only a single observation can be made each evening, the best hour for it is between 9 and 10 o'clock p.m. Observers must remember that in a case like this "every little helps," and the results that have been already obtained warrant the belief that by concerted effort information of practical value may be secured.

AT the meeting of the French Meteorological Society on Dec. 1 last, M. Angot presented the results of temperature observations made during the year 1890 on the Eiffel Tower at 515 feet, 646 feet, and 990 feet above the ground. During the night, the temperature increases up to a mean height of about 500 feet, then decreases, slowly at first, and afterwards more rapidly; at about 1000 feet the mean decrease of temperature is about  $1^{\circ}4$  per 328 feet (100 metres). During the day, the temperature decreases constantly from the ground upwards; in the lower strata the decrease is slower in winter than in summer. In the

latter season it amounts to  $2^{\circ}5$  per 328 feet; but above 500 feet the rate of decrease does not show a decided annual variation; the amount is about  $1^{\circ}6$  per 328 feet. It is worthy of remark that at a height of 984 feet (300 metres) in open air, the decrease of temperature is extremely rapid, both during the night and during the day, and nearly approaches the theoretical value of the law of the adiabatic expansion of gases. M. L. Teisserenc de Bort gave an account of Dr. Hildebrandsson's observations on the motions and heights of clouds. A study of their direction showed that, first, the air which moves in a spiral towards the centre of a depression, having attained a considerable height, moves away from the centre and converges towards the centres of the maxima, and redescends towards the earth by a centrifugal motion. Second, in the northern hemisphere, the direction of an upper wind is always somewhat to the right of that of the lower wind. Thirdly, the mean direction of the upper currents is from west to east in temperate regions, and in the opposite direction in tropical regions. Dr. Hildebrandsson has also published charts of the direction of cirrus clouds, accompanied by theoretical isobars at an altitude of 4000 metres, as proposed by M. Teisserenc de Bort, which show that the motions of the cirrus are quite in accordance with those isobars.

IN the *Anales* of the National Geographical Institute of Costa Rica, vol. iv., Señor H. Pittier has published the results of meteorological observations made at San José during 1889, together with a summary of rainfall and earthquake observations for the years 1866-80. These observations are valuable, as data from Central America are scanty. A comparison of the rainfall curve with the earthquake phenomena shows that the greater number of shocks occur in the months of maximum rainfall—viz. in May and September.

AT a recent meeting of the Chemical Section of the Franklin Institute, Philadelphia, a letter from Mr. M. Carey Lea was read, transmitting to the Section the gift of a collection of his published papers on allotropic forms of silver and a set of specimens of the various modifications of the element which he had prepared. These specimens are greatly valued by the members of the Section.

A VERY large part of the literature of experimental psychology is taken up with the discussion of the psychophysical measurement-methods; and in many cases the psychological question at issue has been lost sight of, in the interest of the methods themselves. One of these, which has been the subject of a good deal of controversy—the method of double stimuli—is finally discredited by Prof. F. Angell in the new part of Wundt's *Philosophische Studien*. Prof. Angell's experimental results are especially interesting, on the positive side, in their relation to Weber's law. Two other articles in the number contain valuable experimentation. Dr. G. Martius proves the erroneousness of the common opinion that there goes along with increasing intensity of a simple clang a continuous decrease of the length of the time of reaction to it. For practised and attentive reagents the time remained the same, within wide differences of stimulation. Dr. A. Kirschmann tabulates the results of his photometric determination of the relations which obtain between "dark" and "light" surfaces, in respect of brightness. It is pointed out that such results furnish in one direction a criterion for art-criticism.

MR. C. J. MURPHY, who has been charged by the U.S. Agricultural Department with the introduction of Indian corn as a human food into Europe, has made a report to Secretary Rusk on his work in Great Britain. In it he reviews the conditions which seem likely to encourage the use of this cereal food in Great Britain and other parts of Europe. Secretary Rusk has caused to be prepared for publication, in conjunction with Mr. Murphy's report, a chapter upon the value of maize as food,

by Dr. H. W. Wiley, chief chemist of the Department, in which are shown the chemical composition of maize, and its relative value for food purposes in comparison with other cereals. There is also a chapter, prepared by the assistant statistician, Mr. E. W. Snow, under the direction of the statistician, offering some additional observations as to the possibility of extending the use of this cereal among the people of Europe as a human food, and presenting a number of statistical tables showing the yield and value of the American corn crop.

AN important *Bulletin* on the forest and mineral wealth of Brazil has lately been issued by the Bureau of the American Republics. The forests of Brazil abound in woods of great value, some of the finest of which are said to be entirely unknown in Europe. With regard to mineral resources, Brazil is not less fortunate. Scientific explorers have found great deposits of coal and iron, and have also proved that the country possesses copper, manganese, and argentiferous lead ore. There are also mines of gold and diamonds. Diamonds are co-extensive with the gold deposits, and, like that metal, are most abundant in Minas Geraes, where they have been found since 1789. The most important locality known for the production of these gems is the district of Diamantina, in the above-named State. They are found in Parana, in the gravels of the River Tibagy, and in the bed of streams dry during the summer. Since the discovery of diamonds at the Cape of Good Hope, the Brazilian production has greatly diminished. As regards iron, the State of Minas Geraes abounds with it. It is not found in veins or strata, buried deep in the earth, but in enormous beds, often lying at the surface, or in mountain masses. These vast deposits are worked only by small scattered furnaces, charcoal being used in the reduction of the ore. Of these small furnaces there are five groups, producing about 3000 tons annually, the product being used in the surrounding districts in the manufacture of articles of home consumption, such as hoes, shovels, picks, drills, nails, horseshoes, &c. In the State of San Paulo are found deposits similar to the best Norwegian ore; and one of the mines is worked by the Government establishment near the village of Sorocaba. This establishment has two furnaces, and produced in one year about 790 tons of pig-iron. The ore has about 67 per cent. of iron. In Santa Caterina, not far from a harbour accessible to the largest vessels, are vast deposits of hematite, containing, on an average, 30 per cent. of manganese, and 20 to 30 per cent. of iron. In the State of Goyaz, as in Minas Geraes, are found enormous masses of the ore itaberrite.

PROF. GEORGE H. WILLIAMS contributes to the latest of the Johns Hopkins University Circulars an interesting account of a geological excursion in Maryland by students of that University in May 1891. The land area of Maryland is approximately 10,000 square miles, which may be in round numbers divided between the three topographically and geologically distinct provinces as follows: (1) *Central Maryland*, called the Piedmont Plateau, with 3000 square miles between the Catoctin Mountain on the west and a line drawn from Washington to Wilmington on the east, exhibits a gently rolling country of moderate elevation and relief. This is composed of the most ancient and contorted rocks—highly crystalline toward the east, and semi-crystalline toward the west. (2) *Western Maryland*, or the Appalachian Mountain province, embracing the 2000 square miles west of Catoctin Mountain. This region is formed of the entire sequence of Palæozoic strata thrown into a series of regular folds or undulations. (3) *Eastern and Southern Maryland*, belonging to the coastal plain, has about 5000 square miles of undisturbed and unconsolidated strata, in nearly horizontal position, and representing the accumulations from the Jurassic to the present. In the course of each year an effort is made to give students of geology at the Johns Hopkins

University a practical acquaintance with the petrography, palæontology, structure, and topography of each of these three provinces by a series of excursions which are conducted exclusively for this purpose. In the excursion in May the route of the party lay along the section through the Appalachian Mountains exposed by the gorge of the Potomac River.

IN the new number of the *Internationales Archiv für Ethnographie* there is a learned and well-arranged paper, by C. M. Fleyte, on the use of the sumpitan and bow in Indonesia. A line may be drawn passing over Flores, to the east of Mangarai and Buru, to the west of Halma-Lera, and to the east of the Philippines, exactly marking the limit of the use of the bow. To the east of this line the bow is in general use, while to the west it is found only sporadically. A second line traced westward of Sumba, eastward of Sumbawa, to the south and east of Celebes, and to the east of the Philippines, marks the limit of the use of the sumpitan, which is found nowhere to the east of it. Between these two lines—on the islands of Sumba, West Flores, Saleyer, Buton, Buru, the Sula Islands, the Banggai Archipelago, and the Sangi and Talaut Islands—neither sumpitan nor bow are known. The author points out that these two limits correspond very closely with the line accepted by Dr. Brandes, separating the eastern from the western branch of the Malayo-Polynesian languages. It appears, therefore, that those natives who use the sumpitan form one family in point of language, and that the like is the case with those who use the bow.

DR. R. W. SHUFELDT contributes to the Proceedings of the U.S. National Museum two interesting prints of Havesu-pai Indians. The prints are reproductions of photographs which were taken several years ago by Mr. B. Wittick, formerly a photographer in the employment of the U.S. Geological Survey. The Havesu-pais live in one of the grandest cañons in Arizona, occupying their primitive lodges along the bank of the stream that passes through it. They are a dying race, and very little is known about them. The styles of their lodges are well shown by Dr. Shufeldt's plates, which also display the varied costumes of the men, women, and children, and the peculiar forms of their baskets. The fashion in which the hair of the women and girls is "fixed" seems to point to affinities between the Havesu-pai and the Pueblan Indians.

IN the new number of *Insect Life*, Dr. C. V. Riley directs attention to what he calls a new herbarium pest. In September 1890, a number of small Geometrid larvæ were found by the botanists of the U.S. Department of Agriculture infesting certain dried plants in the Department herbarium, and especially those which had been received from Mexico and Lower California. The fact that the insect has appeared on dry plants from the comparatively arid western regions may, Dr. Riley thinks, furnish a clue to its original habit. It would seem possible, if not probable, that it normally feeds on the dead or dry plants of Mexico and adjacent arid regions, and that it has simply adapted itself to the somewhat similar conditions prevailing in herbaria. It is a new species, and for the present may be placed in the Acidaline.

MR. W. VERNER writes to the current number of the *Zoologist* that the Kentish plover, like the stone curlew, or thickknee, is being rapidly exterminated in the county from which it derives its name, by collectors and so-called "naturalists," who, with walking-stick guns, in and out of season, destroy all they can approach. "These gentry," says Mr. Verner, "do more harm even than they imagine, for I have come across many small plovers and other birds which have been ineffectually 'peppered,' and have gone away to die. Still oftener I have found nests of the ringed and Kentish

plowers which have been trampled on by these uncouth marauders in their clumsy and ever eager attempts to 'annex' everything they can in the least possible time." The editor of the *Zoologist* pertinently asks why the Wild Birds Protection Act is not put in force.

At the meeting of the Linnean Society of New South Wales on November 25, Mr. Fred. Turner exhibited specimens of *Zeloea orades*, F. v. M. (narrow-leaved form), the Victorian Waratah, collected at the Fitzroy Falls, N.S.W., the most northern habitat yet recorded for the plant; said to be very rare. Also three fungus-smitten grasses from the interior: *Eriochloa punctata*, Hamilt., *Panicum Mitchellii*, Benth. (two valuable pasture grasses—in the case of the second of these the first occasion on which he had seen fungoid growth on it), and *Aristida ramosa*, R.Br., one of the "three awned spear grasses," a noxious plant. To the presence in fodder of parasitic fungi such as these, the fact that many sheep died so mysteriously at times was, Mr. Turner thought, sometimes possibly attributable.

MESSRS. WHITTAKER AND CO. have made arrangements with the editor of *El Telegrafista Español* for the translation into Spanish of Mr. Preece's work upon "The Telephone." The book has already been translated into French and German. The same firm will publish shortly, in a cheap form, Mr. A. R. Bennett's papers on the telephoning of great cities and the electrical parcel exchange system.

WE are glad to welcome the first number of *The Annals of Scottish Natural History*, a quarterly magazine, with which is incorporated *The Scottish Naturalist*. It is edited by J. A. Harvie-Brown, J. W. H. Trail, and W. E. Clarke, and published by David Douglas, Edinburgh. The periodical ought to play an important part in stimulating the study of natural history in Scotland.

AN important botanical work has been planned by T. Durand, *aide-naturaliste* at the Botanic Gardens of Brussels, and H. Schinz, *privatdozent* at the University of Zürich. It is entitled "Conspectus Floræ Africæ," and will be published (by subscription) in six volumes.

THE Botanical Society of Edinburgh prints, in the latest instalment of its Transactions and Proceedings, a capital "preliminary notice" of the Pilcomayo Expedition, by Mr. J. Graham Kerr, naturalist to the Expedition. Mr. Kerr gives a short sketch of the Expedition itself, and then presents a summary of the more striking botanical features of the region traversed by it.

MESSRS. J. AND A. CHURCHILL have published the "Year-book of Pharmacy," comprising abstracts of papers relating to pharmacy, materia medica, and chemistry, contributed to British and foreign journals from July 1, 1890, to June 30, 1891. The volume also contains the transactions of the British Pharmaceutical Conference at the twenty-eighth annual meeting, held at Cardiff, August 1891.

MESSRS. DULAU AND CO. have issued a catalogue of geological works which they offer for sale. The works relate to crystallography, mineralogy, mining, petrography, boulders, caves, vulcanology, water, &c.

SEVERAL new compounds of carbonyl platinum chloride and bromide with ammonia derivatives are described by Dr. Foerster in the current number of the *Berichte*. An account of the interesting carbonyl platinum compounds was given in NATURE,

vol. xliv. p. 530, on the occasion of the publication by Drs. Foerster and Mylius of the results of their investigation concerning them. They were first obtained in 1868 by Schutzenberger by heating spongy platinum first in a stream of chlorine and afterwards in a current of carbon monoxide. The most stable and best investigated of these substances is the compound  $\text{COPtCl}_2$ . It is a crystalline substance possessing a somewhat basic character. The crystals readily dissolve in concentrated hydrochloric acid, forming the hydrochloride  $\text{COPtCl}_2 \cdot \text{HCl}$ . Nevertheless, the substance appears capable of combining with ammonia or its derivatives, for Schutzenberger obtained a compound, to which he assigned the formula  $\text{COPtCl}_2 \cdot 2\text{NH}_3$ , by passing ammonia gas through a solution of carbonyl platinum chloride in carbon tetrachloride. As this ammonia compound does not readily lend itself to accurate analysis, Dr. Foerster determined to prepare a compound with a base such as aniline or pyridine, which would probably form crystals more capable of thorough investigation. For this purpose he chose the base pyridine,  $\text{C}_5\text{H}_5\text{N}$ . He finds that carbonyl platinum chloride does not combine with two, but with one molecule of the base, to form the compound  $\text{COPtCl}_2 \cdot \text{C}_5\text{H}_5\text{N}$ . This result is all the more satisfactory, inasmuch as Zeise has shown that the compound ethylene platinum chloride,  $\text{C}_2\text{H}_4\text{PtCl}_2$ , forms an analogous compound with one molecule of ammonia of the composition  $\text{C}_2\text{H}_4\text{PtCl}_2 \cdot \text{NH}_3$ . The new compound with pyridine,  $\text{COPtCl}_2 \cdot \text{C}_5\text{H}_5\text{N}$ , is a crystalline substance possessing basic properties, combining with hydrochloric acid to form the hydrochloride,  $\text{COPtCl}_2 \cdot \text{C}_5\text{H}_5\text{N} \cdot \text{HCl}$ . Another new compound is obtained from the hydrochloric acid solution by the addition of more pyridine dissolved in alcohol, crystallizing out upon allowing the solution to stand a short time. When recrystallized from alcohol, this second compound is obtained in fine greenish-yellow crystals. Its empirical composition is  $\text{COPtCl}_2 \cdot \text{C}_5\text{H}_5\text{N}$ , but its molecular composition is probably represented by the double formula—



Water instantly decomposes it. In a similar manner two analogous compounds containing bromine have been obtained. The first of these,  $\text{COPtBr}_2 \cdot \text{C}_5\text{H}_5\text{N}$ , crystallizes in yellow tabular or acicular prisms, melting at the temperature, very low for a platinum compound, of  $78^\circ$ . The second compound,  $(\text{COPtBr})_2(\text{C}_5\text{H}_5\text{N})_2$ , is distinguished by its difficult solubility, only chloroform dissolving it in sufficient quantity for the purpose of recrystallization.

In addition to the above compounds with pyridine, an interesting compound with phenylhydrazine has been obtained,  $\text{COPtCl}_2 \cdot \text{C}_6\text{H}_5\text{N}_2\text{H}_3$ , in fine crystals. The hydrochloride of this compound,  $\text{COPtCl}_2 \cdot \text{C}_6\text{H}_5\text{N}_2\text{H}_3 \cdot \text{HCl}$ , has also been prepared; it forms remarkably beautiful orange-coloured crystals. Indeed, it appears highly probable that hydrazine itself,  $\text{N}_2\text{H}_4$ , would be found to combine with these carbonyl compounds of platinum in a manner similar to ammonia and its derivatives.

THE additions to the Zoological Society's Gardens during the past week include a Diana Monkey (*Cercopithecus diana* ♀) from West Africa, presented by Mrs. R. Godfrey; a Rough-eyed Cayman (*Alligator sclerops*) from South America, presented by Mr. Charles Taylor; four Mississippi Alligators (*Alligator mississippiensis*) from South Carolina, presented by Mr. W. S. Copleston; four Gouldian Grass Finches (*Poephila gouldiae*), two Crimson Finches (*Estrela phæton*) from Australia, purchased; four Beautiful Grass Finches (*Poephila mirabilis*) from Australia, purchased.

OUR ASTRONOMICAL COLUMN.

WOLF'S PERIODIC COMET.—The following ephemeris, due to Dr. Berberich, is from one contained in *Edinburgh Circular* No. 21:—

1892.	Right Ascension.		Declination.	Brightness, that at discovery being = 1.
	h. m. s.	° ' "		
Jan. 6	4 15 15	...	- 13 39 5	3.24
" 10	16 22	...	13 9 8	2.93
" 14	17 55	...	12 36 9	2.66
" 18	19 52	...	12 1 4	2.41
" 22	22 10	...	11 23 8	2.19
" 26	24 50	...	10 44 7	1.99
" 30	27 51	...	10 4 5	1.81
Feb. 3	31 12	...	9 23 7	1.65
" 7	34 48	...	8 42 6	1.51
" 11	38 42	...	8 1 6	1.38
" 15	42 50	...	7 20 9	1.26
" 19	47 12	...	6 40 8	1.15
" 23	51 46	...	6 1 5	1.07
" 27	56 33	...	5 23 2	0.96
March 2	1 30	...	4 46 0	0.89
" 6	6 37	...	4 10 1	0.82
" 10	11 53	...	3 35 5	0.76
" 14	17 17	...	3 2 4	0.70
" 18	22 48	...	2 30 8	0.65
" 22	28 26	...	2 0 9	0.60
" 26	34 9	...	1 32 7	0.56
" 30	39 58	...	1 6 0	0.52

The comet is now a comparatively faint object, but can be seen with instruments of moderate aperture. It is in Eridanus, and moving slowly towards Orion. It has the same declination as Rigol on February 9, and passes about 4° north of this star on March 7.

THE DIFFRACTION EFFECTS PRODUCED BY PLACING SCREENS IN FRONT OF OBJECT-GLASSES formed the subject of a communication by Prof. Pritchard to the Paris Academy on December 28. The paper deals with the effects produced by meshes of metallic wires on the photographic and visual images of stars in the focus of refractors (photographic and ordinary) and reflectors. Numerous screens have been used in the investigation, but only the results obtained with three, designated by A, B, and C, are described. A was an iron wire screen having very nearly square meshes about 0.9 mm. apart, B a bronze one with meshes having an area of about 0.225 square mm., and C one having circular holes about 2.3 mm. diameter in it. Photometric observations of the intensities of the visual images of a bright star with and without A gave the relation 1/3.636 which, expressed in units of stellar magnitude of the ordinary scale, corresponds to an absorption by the screen of 1.40 magnitude. The same screen placed in front of a photographic telescope reduced stars of the ninth to the eleventh magnitude. There was thus a variation of 2/3 of a magnitude in the effect produced by the same screen on the visual and photographic images of the same star. B intercepted light equivalent to 2.4 magnitude in the case of the observing telescope, and 2.8 magnitude in the case of the photographic one. C gave the values 1.44 and 1.83 magnitudes respectively. In all cases, therefore, the absorption of light was greater for the photographic than for the visual image. This is most probably due to the different treatment of the lenses by the optician in correcting them for photographic or visual work. Using the same screens in connection with reflectors, the intensities of the visual and photographic images were found to be the same, and the quotient of the intensity without a screen into the intensity with a screen was very nearly equal to the square of the portion of the screen traversed by the light.

REFRACTIVE POWER OF COMETARY MATTER.—Mr. Barnard communicates a paper to the *Astronomische Nachrichten*, No. 3072, on observations made of the difference of declination of 21 Asterope and 22 Asterope at the passage of Wolf's comet, 1891 September 3, through the Pleiades. As the opportunity afforded a good test to determine the refractive power of cometary matter, he, together with Mr. Burnham, instituted a series of measures of the declination of these stars before, during, and after, the transit of the comet over Asterope. Mr. Burnham's observations were made with the filar micrometer of the 36-inch equatorial, while Mr. Barnard used that of the

12-inch. The results obtained by the former indicated a small change, so small indeed that Mr. Barnard with his instrument could not detect any variation, or at any rate any difference of reading that would not be masked in the errors of observation. Mr. Burnham's measures are shown in the form of a curve, a vertical line corresponding to the time of nearest approach of the nucleus to Asterope, while a horizontal one indicates the mean  $\Delta\delta$ . The dots representing the observations gradually increase their declination, and then more quickly decrease, rising again only when the comet has transited the star. The results are most interesting, and the following is a short extract from the table. The time of nearest approach of the star and the nucleus occurred at 2h. 8.7m. sidereal time.

Difference of Declination between 21 Asterope and 22 Asterope.

Sidereal time.		Individual readings.	
h. m.	s.	h. m.	s.
2	15	...	95.07
	25	...	94.60
	35	...	94.95
	45	...	95.06
	55	...	95.15
	65	...	94.88
	75	...	94.77
	85	...	94.64

Sidereal time.		Individual readings.	
h. m.	s.	h. m.	s.
2	95	...	94.86
	105	...	94.75
	115	...	94.79
	125	...	94.98
	145	...	94.07?
	155	...	94.87
	165	...	95.17
	175	...	95.12

HIMMEL UND ERDE.—The December number of this "monthly" contains an interesting article by Dr. W. Zenker on "The Heating of the Earth's Surface by the Sun." That on "The Great Ice Age," by Prof. Dr. Albrecht Penck, begun in the November number, is here completed.

WASHINGTON OBSERVATIONS, 1886.—This volume, just issued, contains the results of all the observations made during the year 1886 at the United States Naval Observatory, under the superintendence of Commander A. D. Brown, U.S.N. Under the heading of "The Transit Circle" and "The Meridian Transit Instrument," are given descriptions of the instruments, catalogues of miscellaneous stars observed, constants used in reductions, adopted corrections, clock rates and corrections, positions and semi-diameters of sun, moon, and planets, and many other details. Under "Observations and Results" are tabulated all the results obtained by the use of the transit circle, meridian circle, the equatorials of 26 and 9.6 inch aperture, &c. The magnetic observations made during the years 1888 and 1889 at the same Observatory by Ensign J. A. Hoogewerf, U.S.N., under the superintendence of Captain F. V. McNair, U.S.N., are also given, including both tabular statements and fourteen large plates.

MOLECULAR WEIGHT OF GADOLINIA.

*In Bihang till K. Svenska Vet.-Akad. Handlingar*, Band 17, Afd. ii., No. 1, Prof. A. E. Nordenskiöld returns to a subject which will always have a peculiarly fascinating interest for chemists. In spite of the vast amount of time and labour which has been expended upon the investigation of the rare earths contained in such minerals as gadolinite and samarskite, the mystery involved in the peculiar nature and reciprocal relations of these bodies is still far from having been solved.

It was in 1794 that Gadolin first examined the mineral gadolinite. Since that time the exceedingly complex nature of the new earth which he discovered has been continually demonstrated. Every fresh investigation seemed to result in the announcement of the discovery of a new element. The task of separating these different earths, which are so closely allied in their chemical properties, was exceedingly difficult and tedious. Mosander was one of the first to make use of the process of fractional precipitation, which, combined with spectroscopic methods, has in the hands of such scientific men as Delafontaine, Marignac, Lecoq de Boisbaudran, and Crookes, led to such interesting results. The investigations of Crookes on these rare earths resulted in the famous lecture on the "Genesis of the Elements," delivered before the Royal Institution in 1887.

The mention of this remarkable lecture brings us to the subject of the present paper, for one of the arguments employed by Crookes was that we had proof of the existence in nature of a mixture of isomorphous bodies, always associated together, and presenting a molecular weight so constant that they almost constitute a single body. That statement was made by giving

importance (an exaggerated importance according to Marignac's criticism) to an interesting observation made by Prof. Nordenskiöld, who had announced (*Comptes rendus*, ciii. (1886), 795) the fact that the crude mixture of yttria earths, as precipitated from different minerals, although really a compound body, has nevertheless always a constant molecular weight, whatever may be the mineral from which it is extracted. To this mixture of earths, which thus behaves like an element, Prof. Nordenskiöld gave the name gadolinia, or oxide of gadolinium. In a subsequent paper (*Öfversigt af Vetenskaps-Akademiens Förhandlingar*, 1887, No. 7) in answer to the criticisms of Marignac and Rammelsberg, he showed that although the molecular weights for the individual earths which make up gadolinia vary between 136 and 394, yet the molecular weight for the mixture as a whole, obtained from a number of different minerals from various localities, only varied from 258 to 271.

The work of which an account is given in the paper now before us was undertaken in order to discover whether the above slight differences were only dependent on variations in the experimental methods. The author has not attempted to make any separation of the individual earths, but has confined himself to further determinations of the molecular weight of the group as a whole. The result of fifty-four determinations made upon such minerals as gadolinite, orhite, samarskite, monazite, &c., from various localities was to show that gadolinia from widely different sources has a molecular weight ranging from 247.9 to 275.8. The gadolinia used in these determinations was obtained by first separating the cerium metals by precipitation with potassium sulphate, precipitating the filtrate with ammonia, dissolving this precipitate, and reprecipitating with oxalic acid. Care was taken to avoid any fractionation which might occur, but any fear on this account was discounted by the unexpected discovery made during the course of the work that any gadolinia fractioned out (e.g. thrown down with the cerium oxides in the  $K_2SO_4$  precipitate) had a molecular weight differing only very slightly from that of the rest of the earth.

The criticism which the author next applies to eighty-one molecular weight determinations made by Blomstrand, Engström, Rammelsberg, and others, leads to the rejection of forty, either owing to the small amount or to the impurity of the material used. The numbers in the case of the forty-one determinations retained fall within the limits obtained by the author.

Now, the molecular weights of the twelve earths which are at present stated to enter into the composition of gadolinia range from that of scandia, 136, and yttria, 227, to that of ytterbia, 394; so that the fact that, in spite of this wide divergence in the molecular weights of the constituents, the molecular weight of gadolinia itself only varies by at most 5.4 per cent. from the mean value, 262, is sufficiently startling. Thus no gadolinia has yet been found containing exclusively one only of these individual earths. The author shows, by a review of other minerals containing isomorphous groups of elements, how distinct in this respect is the behaviour of this group of yttria earths.

We have seen what use Crookes has made of these curious facts. We will conclude, therefore, by giving Marignac's conclusions on the same subject, as contained in his criticism of the author's previous paper. He is of opinion that all that can be affirmed is that yttria is always met with in nature mixed with a variable number of analogous and isomorphous earths of much higher molecular weight, and that it is always the dominating element in this mixture. G. T. P.

SOCIETIES AND ACADEMIES.

LONDON.

Physical Society, December 18, 1891.—Prof. W. E. Ayrton, F.R.S., President, in the chair.—The President announced that it had been found necessary to alter the dates of the meetings to be held after Christmas from those already published to the following: January 22, February 12 and 26, March 11 and 25, April 8, May 13 and 27, June 10 and 24.—A note on interference with alternating currents was communicated by Mr. M. H. Kilgour. Whilst studying Dr. Fleming's paper on some effects of alternate current flow in circuits having capacity and self-induction, the author constructed some additional curves. He was thereby led to investigate whether the serious rises of pressure produced by adding capacity would occur over considerable ranges of capacity, or whether they would only take place when the capacity was nearly equal to a particular value.

Taking the case of a condenser of capacity C farads, in series with a circuit of resistance R ohms, and inductance L henrys, he showed that the maximum value of  $\lambda$  (the ratio of the pressure across the condenser terminals to that across the condenser and inductive resistance) is obtained when

$$C = \frac{L}{R^2 + \beta^2 L^2} \dots \dots \dots (1)$$

where  $\beta = 2\pi$  times the frequency. The maximum value of  $\lambda$  produced by this capacity being given by the expression

$$\Lambda = \frac{\sqrt{R^2 + \beta^2 L^2}}{R} \dots \dots \dots (2)$$

Taking R = 10, and  $\beta = 2\pi \cdot 1000$ , curves plotted from equations (1) and (2) between C and  $\Lambda$ , and between  $\Lambda$  and L had been drawn. The CL curve rises to a very sharp peak at  $L = 0.0015$ , and falls rapidly. That between  $\Lambda$  and L starts horizontal and bends upwards, and approximates to an inclined straight line for values of L greater than 0.002; when  $L = 0.1$ ,  $\Lambda = 63$ . Considering the question of the range of capacity with which a given rise of pressure can occur, it was pointed out that when the values of L, R, and  $\beta$  are such as to make a large rise possible, a rise exceeding a moderate value can only be obtained for values of C differing little from that given by equation (1). On the other hand, when the circuit is such that the maximum rise possible is not large, then a rise exceeding a given moderate value can be obtained over a much wider range of capacity. Hence the author concludes that the larger the possible rise the smaller is the probability of a serious rise occurring. The effect of shunting the condenser by a circuit of resistance r and inductance l is next dealt with in the paper, and the values of C which make  $\Lambda$  a maximum determined, as well as the maximum value L can have. Subsequently the author examines whether the practical case of an alternator feeding a transformer through a concentric cable may be simplified without introducing serious error by assuming the capacity concentrated at either end of the cable, and concludes that in ordinary cases little error will be thus made. In an experiment made with a 100 kilowatt alternator,  $\frac{3}{4}$  mile of  $\frac{11}{16}$  concentric cable, and an 18 kilowatt transformer, a rise of  $\frac{1}{2}$  per cent. was found to occur at the terminals of the alternator when the cable was connected. Putting on the transformer unloaded or loaded with but a dozen 16 candle-power lamps produced little change in the rise of pressure, this in all cases being between 0.2 and 0.3 per cent. Dr. Sumpner asked whether the conclusions as to the range of capacity with which a given rise of pressure was possible, were true for small rises such as occur in practice. Cases where the maximum possible rise was of the order 63 were not likely to occur at ordinary frequencies. The highest rise he had ever known was 11. He thought the time-constant of the inductive coil chosen—viz.  $\frac{1}{1000}$  of a second—was very large. In circuits containing iron it was, practically impossible to get such large time-constants, for the power spent in the iron increased the effective resistance. Referring to the narrow range of capacity within which large rises were possible, he pointed out that such cases were found in Hertz's resonators, where the rises were immense, but to obtain them the adjustments had to be very accurately made. Dr. S. P. Thompson said he regretted that Prof. Fleming was not present, for he had recently investigated Hertz's experiments, and had obtained curves very similar to those got for the Depford mains. The curve between  $\Lambda$  and L was very interesting. It was, in fact, a curve between the secant of the angle of lag and  $L$ , as could be seen from formula (2). In practice one would be working on the lower portion, and hence the rises would be small. Mr. Kilgour explained that in the paper his first object was to show that the product of the range of capacity between which a rise greater than a given value would occur and the maximum possible rise was approximately constant for different circuits. Secondly, he wished to prove that the capacity of concentric cables could be assumed to be localized at either end without introducing much error in the rises of pressure calculated therefrom. Dr. Thompson, speaking of nomenclature, regretted that the word inductance should be used sometimes for L and at other times for  $L\beta$ , and thought its meaning should be restricted to the latter. Prof. Perry said a name was needed for coefficient of self-induction. Resistance was practically independent of frequency, and "inductance" should have no reference to frequency. Dr. Sumpner thought it important to have a name for  $L\beta$ , for that quantity comes into calculations most frequently. He would have preferred that



"inductance" should mean  $L_p$ , but Mr. O. Heaviside, who introduced the term, had used it for  $L$ . The President remarked that some time ago Dr. Sumpner and himself felt the need of a name for  $L_p$ , and thought of using "inductance," but on referring to Mr. Heaviside's articles found it used for  $L$ . Dr. C. V. Burton asked whether the word "self-induction" could not be used as an abbreviation for "coefficient of self-induction." Dr. Thompson pointed out that this word already had a meaning, viz.  $L$  multiplied by current. Dr. Burton then suggested that inductivity might be applicable. Dr. Thompson said the word "impedance" was also used ambiguously, for the sense in which Dr. Lodge uses it in his "Modern Views of Electricity" is not the same as the vector sum of  $R$  and  $L_p$ . Prof. Perry recalled the fact that "impedance" had been defined by the Committee of the British Association as the ratio  $\frac{\text{effective voltage}}{\text{effective current}}$ . Dr. Thompson said this definition was

only applicable to periodic currents, and not to intermittent or transient ones. The President said he understood the first object of Mr. Kilgour's paper was to inquire whether the dread of rise of voltage occurring when concentric mains were used need exist. When Dr. Fleming's paper was read, the general idea was that concentric cables were dangerous. In the discussion on it, he, amongst others, had pointed out that the chance of a large rise of pressure was not a serious one. Mr. Kilgour had now shown that the range of capacity over which a particular rise could occur is inversely proportional to the maximum rise possible in the particular circuit. When the circuit was such that a large rise was possible, the probability of any serious rise taking place was very small, hence the fears of large rises were more or less unfounded. The second part of the paper was to show that ordinary problems on concentric cables could, in practice, be treated with sufficient accuracy by assuming the capacity localized at either end of the cable, instead of distributed along its length.

**Royal Microscopical Society, December 16, 1891.**—Dr. R. Braithwaite, President, in the chair.—Mr. E. M. Nelson said he had severely tested Messrs. Powell and Lealand's new apochromatic  $\frac{1}{2}$  of 1.4 N.A. both visually and photographically, and he could say it was remarkably fine glass. It gave an image more free of colour than that of many apochromatics he had seen; its speed in microphotography was very great. He noted it was fitted with a correction collar.—Mr. H. Bernard exhibited and described a new form of mechanical stage which he had invented; it was specially designed to obviate the inconvenience arising on account of the very limited range of motion admitted by those at present in use. The plan which he had tried to follow was to imitate the movement of the fingers as they are used for moving glass slides under the microscope. The mechanism was all under and at the side of the stage. Slides were moved by light adjustable frames. In this way a movement of 10 cm. by 5 cm. was speedily obtained without jarring against the condenser, or interfering with the light. Large slips with series of sections could thus be very easily examined, and zoophyte troughs could be searched from corner to corner. By placing a brass plate on the movable frame it was shown that the contents of a watch-glass could be closely examined, the movement avoiding the usual shaking of the fluid caused when watch-glasses are manipulated by the fingers. He had shown the original drawings of the stage to Prof. Abbe, who thought the idea was so good that he had had the stage exhibited made by the firm of Zeiss. The President, in thanking Mr. Bernard for bringing this stage to their notice, expressed the opinion that it was likely to be found most useful for dissecting purposes. He had often felt the inconvenience arising from the want of a greater range of movement in the ordinary mechanical stage. After the business of the meeting was over, Mr. Bernard gave a demonstration to the Fellows, and very favourable comments were passed on its practical use and originality.—Prof. J. W. Groves read a letter from Mr. Hermann giving information that *Volvox globator* was to be found in great abundance in a pond in the neighbourhood of Balham.—A paper on the resolution of *Podura*, by the Hon. J. G. P. Vereker, was read by Prof. Groves. The author stated that he had been experimenting in photomicrography on some scales of *Podura*, and had obtained results which he thought threw some light upon their structure. The photomicrographs exhibited he considered appeared to prove that the *Podura* scale consists of a hyaline beaded membrane, having minute featherlets inserted in it. At the broadest part of the scale

there are one or two rows of beads between the featherlets, while towards the base and top of the scale the beads tend to form single rows. Mr. E. M. Nelson believed that the effects were due to the thickening of the membrane. Mr. J. E. Ingpen said that Mr. Wenham had gone into this subject, and he had come to the conclusion that the markings were inflations of the membrane.—The President reminded the Fellows that the next meeting would be the anniversary, and that it would therefore be necessary to appoint two auditors to examine the treasurer's accounts; on behalf of the Council he had appointed Mr. W. T. Suffolk. Mr. Nelson proposed, and Mr. Wynne E. Baxter seconded, Mr. J. M. Allen as auditor on the part of the Fellows. This was put to the meeting and unanimously carried.

EDINBURGH.

**Royal Society, December 21, 1891.**—Dr. William Craig in the chair.—Prof. Crum Brown communicated an obituary notice of the late Mr. Andrew Young, by the Rev. Prof. Flint.—Prof. Crum Brown also read a preliminary communication, by Dr. Dawson Turner, on the electric resistance of various urines. The electric resistance is found to vary markedly with the proportion of solid constituents in solution is different. This test promises to be of use to the medical practitioner. Kohlrausch's method of determining the resistance by alternating currents and the telephone was adopted.—Mr. Malcolm Laurie read a paper on some Eurypterid remains from the Upper Silurian deposits of the Pentland Hills. This collection of fossils is now in the Edinburgh Museum of Science and Art, and contains a number of new forms, one of which has been the type of a new genus—*Drepanopterus*. This form is characterized by great breadth of carapace, and by the form of the single limb which is preserved. The limb is long and narrow, and ends in a slightly expanded sickle-shaped segment. The genus appears to occupy a position intermediate between *Eurypterus* and *Stylonurus*. Among the other remains are found two new species of *Stylonurus*—*S. ornatus* and *S. macrophthalmus*. Two new species of *Eurypterus* are also represented—*E. conicus* and *E. cyclophthalmus*. The second species of *Stylonurus* and both species of *Eurypterus* are characterized by exceptionally large eyes.—Prof. Cosser Ewart read the second part of a paper, written by himself and Mr. J. C. Mitchell, on the lateral sense-organs of Elasmobranchs. In this part the authors dealt with the sensory canals in *Raia batis*. It has been supposed that these canals serve for the production of mucus. The authors consider that this idea must be abandoned. They have observed a number of mucus glands in the skin sufficient to account for all the mucus found on the surface. They incline to the opinion that the canals have some respiratory function.

PARIS.

**Academy of Sciences, December 28, 1891.**—M. Duchartre in the chair.—On a telescope *reseau*, by M. Mascart.—Note, by M. Faye, accompanying the presentation of the *Annuaire du Bureau des Longitudes* for 1892.—On the number of roots common to several simultaneous equations, by M. Kronecker.—Another note on the same subject, by M. mile Picard.—On the glycolytic and saccharifying powers of the blood in hyperglycemic asphyxia, in phloridic diabetes, and in the diabetes of man, and on the localization of the saccharifying ferment in the blood, by MM. R. Lépine and Barral.—Note on the diffraction effects produced by screens placed in front of photographic and ordinary object-glasses, by Prof. Pritchard. (See Our Astronomical Column.)—On conjugate systems with equal invariants, by M. G. Koenigs.—On the theory of linear differential equations, by M. André Markoff.—Complement to one of Abel's problems, by M. Bougaieff.—On a new spectrometer (*réfractomètre*), by M. C. Féry. The principle upon which the instrument has been constructed consists in annulling, by a solid prism of variable angle and constant index of refraction, the deviation produced by a hollow prism having a constant small angle, and filled with the liquid whose refractive index is required. To realize these conditions, a prismatic-shaped cavity has been cut out of a double-convex lens in a plane perpendicular to the axis. This cavity is filled with the liquid under examination. And since, in a lens, the angle formed by the plane tangents to the surfaces of curvature is sensibly proportional to the distance from the optical centre, the angle of the lens considered as a prism can be varied by motion in a plane perpendicular to the axis. The amount of lateral motion necessary to bring about no deviation, when

the lens containing a liquid is placed between a collimator and an observing telescope, furnishes the datum from which the index of refraction of the liquid can be calculated. The determinations that have been made indicate that the method is susceptible of high accuracy.—Researches on the application of measurements of rotatory power to the determination of combinations formed by sorbite in aqueous solution with acid sodium and ammonium molybdates, by M. D. Gernez.—Metallic borates, by M. H. Le Chatelier. The author has prepared, purified, and analyzed borates of magnesium, calcium, and zinc. He concludes that many of the complex borates previously described are in reality mixtures of comparatively simple borates with boric anhydride, and that the only types of borates of this composition is sufficiently established are:  $B_2O_3$ , 3MO;  $B_2O_3$ , 2MO;  $B_2O_3$ , 1.5MO; and  $B_2O_3$ , MO.—On isomeric chromic sulphates, by M. A. Recoura.—On a silicon chlorosulphide, by M. A. Besson. The compound  $Si_2Cl_2S_2$  has been obtained as a white solid, crystallizing in long needles melting at  $74^\circ$ , readily decomposing in the air, and acted on with violence by water.—A new crystallized copper phosphide, by M. Granger.—The solution of antimony chloride in saturated solutions of sodium chloride, by M. H. Causse.—On a double cyanide of copper and ammonium, by M. E. Fleurent.—Study of the thermal properties of dibasic organic acids: influence of the alcoholic function, by M. G. Massol.—Disodium glycol, by M. de Forcrand.—Action of dilute nitric acid on nononaphthene, by M. Konovoff.—The formation of acetylene from bromoform, by M. P. Cazeneuve.—Action of phosphorus pentachloride on methylnaphthyl ketones:  $\alpha$  and  $\beta$  naphthylacetylenes, by M. J. A. Leroy.—Observations on the subject of a note of MM. Arm. Gautier and R. Drouin, by MM. Th. Schlessing, fils, and Em. Laurent.—On the formation of cordierite in the sedimentary rocks fused by the coal fires at Commeny (Allier), by M. A. Lacroix. An examination of some rock specimens from Commeny, where the underground combustion of coal has been going on for some time, shows that the most abundant mineral constituting the lavas formed (especially the ropy varieties) is cordierite. This mineral occurs in small crystals, which have not, however, been isolated and analyzed. It is accompanied by octahedral spinellidite in connection with anorthite, and small, almost rectangular, microclites. The augite often exhibits the chondritic structure of meteorites. The variation in the relative abundance of cordierite, anorthite, and augite, their very unequal dimensions in different specimens, and the relative abundance or rarity of the glass, give rise to numerous interesting petrographical varieties. Mallard's rhabdite has been easily recognized. The facts show that cordierite is easily formed by the action of heat on sedimentary rocks; indeed, it appears from the observations to be an habitual product of Carboniferous rocks modified by heat.—Functions of the pectiniform organ of scorpions, by MM. Charles Brongniart and Gaubert.—On the régime of the oceanic sardine in 1890, by M. Georges Pouchet.—On the presence of *Heterodera Schachtii* in cultures of carnations at Nice, by M. Joannes Chatin.—On a phthisis of fibrous copper, caused, in an infant of five months, by *Phthisis inguinalis*, by M. Trouessart.—Observations on the cellulose membrane, by M. L. Mangin.—On the penetration of the violet filaments of the Rhizoctone fungus in the roots of beetroot and lucern-grass, by M. Ed. Prillieux.—On the assimilation of parasitic plants by chlorophyll, by M. Gaston Bonnier.—Earthquake of October 28, 1891, in Central Japan, by M. Wada.

## BERLIN.

Physiological Society, December 11, 1891.—Prof. du Bois Reymond, President, in the chair.—Prof. Fritsch gave an account, illustrated by specimens and preparations, of the general result of his investigations on feebly electrical fishes, as far as these deal with the structural arrangement of the electric organ, the nerves to the same, and the nerve centres.—Dr. C. Benda spoke about his recent researches on spermatogenesis, entering fully into the part played by the archoplasm in the development of spermatozoa.

Physical Society, December 18, 1891.—Prof. Kundt, President, in the chair.—Prof. Schwalbe recalled to the Society the loss it had sustained in the death of Dr. Ewald, one of its earliest and formerly most active members.—Dr. Budde gave a résumé of the work which has been done during the last ten years on supersaturated solutions, and an account of the present state of the question.—Dr. Paschen spoke on gravitational

attraction and its measurement by Cavendish and his successors, dealing specially with the work of Boys, whose methods he explained and whose apparatus he exhibited to the Society.

## AMSTERDAM.

Royal Academy of Sciences, December 19, 1891.—Prof. van de Sande Bakhuyzen in the chair.—Dr. Bakhuis Roozeboom treated of the influence of isomorphism on the behaviour of double salts during solution. He studied the isotherm of  $15^\circ$  for the saturated solutions possible with the system  $FeCl_3$ ,  $NH_4Cl$ , and  $H_2O$ . When representing the numbers of mol.  $FeCl_3$  and  $NH_4Cl$  per 100 mol.  $H_2O$  in the solution, this isotherm consists of three branches. The first gives the solutions in equilibrium with solid  $FeCl_3 \cdot 6H_2O$ , the second with the double salt  $FeCl_3 \cdot 2NH_4Cl \cdot H_2O$ , the third with mixed crystals containing from  $\pm 8$  per cent.  $FeCl_3$  to zero. The three branches have two points of sharp intersection. In the first coexist the double salt with  $FeCl_3 \cdot 6H_2O$ , in the second the double salt with mixed crystals containing the highest possible percentage of  $FeCl_3$ . These results confirm the rule that with systems of three bodies the composition of a solution is variable when only one solid phase lies at the bottom, but determined when there are two solid phases. The occurrence of mixed crystals besides double salts modifies the behaviour of the solution when one or other of the composing salts is added continuously.—Mr. J. A. C. Oudemans spoke on levels. He had had to try two levels of an altazimuth of the Sumatra triangulation, having each an air chamber at one of their ends; using a bubble not longer than one-third of the scale, he found the value of a division in the first and last third two or three times larger than in the middle, so that he inclined to reject the levels. But trying the same levels with long bubbles—for instance, of two-thirds of the scale—they proved much better, the inclination given by the level-trier being nearly proportional to the indication of the level, and the remainder of the irregularity being easily taken into account by a table. The necessity of making up, by experiment, a table of the inclination in a function of the level-reading, being once admitted, the judgment about a level ought to depend, not so much on the uniformity of the curvature, as on the constancy (the bubble remaining of the same length) of the reading, the inclination being the same; which property may easily be tested by the level-trier.

## CONTENTS.

	PAGE
Indian Meteorology. By H. F. B. . . . .	217
French Malacology. By (BV) <sup>2</sup> . . . . .	219
Man's Place in Nature. By C. R. . . . .	220
Our Book Shelf:—	
Merrill: "Stones for Building and Decoration" . . . . .	222
Acloque: "Les Champignons" . . . . .	222
Maxwell: "Theory of Heat" . . . . .	222
Letters to the Editor:—	
The Implications of Science.—Dr. St. George	
Mivart, F.R.S.; Miss E. E. C. Jones . . . . .	222
Supernumerary Rainbows observed in the Orkneys.—	
Robert H. Scott, F.R.S.; M. Spence . . . . .	223
Aurora Borealis.—J. Lovel . . . . .	223
A Double Moon.—Rose Mary Crawshay . . . . .	224
On the Relation of Natural Science to Art. II. By	
Prof. E. du Bois-Reymond, F.R.S. . . . .	224
Chronophotography, or Photography as applied to	
Moving Objects. (Illustrated.) By W. . . . .	228
Sir George Biddell Airy . . . . .	232
Notes . . . . .	233
Our Astronomical Column:—	
Wolf's Periodic Comet . . . . .	237
The Diffraction Effects produced by placing Screens	
in front of Object-Glasses . . . . .	237
Refractive Power of Cometary Matter . . . . .	237
Himmel und Erde . . . . .	237
"Washington Observations, 1886" . . . . .	237
Molecular Weight of Gadolinia. By G. T. P. . . . .	237
Societies and Academies . . . . .	238

THURSDAY, JANUARY 14, 1892.

*THE CHEMISTRY OF PAINTS AND PAINTING.*

*The Chemistry of Paints and Painting.* By A. H. Church, M.A., F.R.S. (London : Seeley and Co., 1890.)

CONSIDERING the widespread interest which attaches to all matters connected with pictures and painting, it is perhaps somewhat surprising that up to within quite recent times no attempt has been made to discuss and review in a comprehensive and efficient manner the materials and methods of painting from a strictly chemical point of view. It will, however, be readily conceded that the field is an extensive one, and it is, moreover, obvious that an intimate acquaintance with the technique of painting will be found only very rarely associated in the same individual with a thorough knowledge of chemistry. Neither a mere chemist nor a mere artist could undertake the task with a fair prospect of success.

The author of the present volume, on accepting, some years ago, the Professorship of Chemistry in the Royal Academy of Arts, found there a congenial sphere of activity, and an opportunity of devoting himself thenceforward to chemistry in its bearing on pigments and painting—a subject which long before had had a great attraction for him, as evinced by his early publication referring to these matters, and also by the fact that he has himself practised with no inconsiderable success the art of painting. It is thus that the information given in this work is derived on the one hand from an exact scientific study, whilst on the other hand it is based upon a knowledge of the technical details of the art. As it has been written especially with the view of explaining to the artist and the art student the more important chemical and physical characters of the materials they employ, and of the processes they manipulate, the author has exercised commendable discretion in not encumbering the text with chemical detail beyond the general scope of those for whom the book is intended.

"In many instances a sketch of the processes for preparing certain pigments and varnishes is given, not in order to turn the painter into a colour-maker or a varnish manufacturer, but rather that he may acquire a clearer insight into the nature and properties of the most important constituents entering into the composition of his pictures."

The author very aptly begins his work by a discussion of the various painting grounds, and briefly describes the essential qualities of paper, vellum, ivory, fresco and sterochrome grounds, of slate and stone, of wood panel and canvas. This part is divided into four short chapters, which contain many valuable practical hints. He next proceeds to the description of the vehicles and varnishes, and this part comprises the oils, resins, waxes, paraffin waxes, yolk and white of egg, size, glue, gums, glycerine, honey, water-glass, lime and baryta-water, solvents and diluents, siccatives and dryers, varnishes and oleo-resinous vehicles.

Describing the several drying oils—namely, linseed oil, poppy oil, and walnut oil, he enters more fully into a

discussion of the first-named as being the typical one, and also by far the most important. Here he gives an account of the proper mode of preparing and purifying the oil, and directs attention to the variation of the qualities of the oil of seed of different origin; he also explains why preference should be given to the cold pressed oils. A very concise and instructive discussion of the chemical composition of linseed oil leads on to a consideration of the chemical change which the oil undergoes in the act of drying. This remarkable change, in which the chief value of these drying oils centres, is greatly accelerated by the presence of certain metallic oxides, such as those of lead, iron, or manganese. Later on, in a chapter devoted to siccatives and dryers, the author directs attention to the excessive and improper use of lead compounds, and very justly refers to the advantage of using instead of them the compounds of manganese, and especially the borate, in the preparation of the strongly drying oils. Such delusive dryers as borates of lime and zinc or sulphate of zinc, however, we think ought to have been mentioned only in order to condemn them.

The chapter on resins, waxes, and solid paraffin, contains a description of these substances and their properties in so far as they are of interest to the painter. In a similar manner the author treats the various other materials considered in this part, such as yolk and white of egg, size, gum, glycerine, water-glass, &c.; and under the head of solvents and diluents we find a very useful and instructive account of the different kinds of oil of turpentine and the liquid hydrocarbons made use of in the artist's studio. Amongst them, oil of turpentine stands foremost in importance. It is to the painter in oil colours what water is to the painter in water colours; and in order to fulfil its function in the most perfect manner, it is essential that it should be pure, and should completely volatilize without leaving any phlegma in the substance of the paint. Oil of turpentine is very prone to become changed and acted upon by the atmospheric oxygen, especially in the presence of moisture and under the influence of light. As the author points out, different kinds of oil of turpentine vary very materially in this respect, and the artist has to be on his guard to select the best kinds for his use. The employment of deteriorated or inferior oil of turpentine may give rise to very serious defects which are often ascribed to other causes. Other hydrocarbons, now available for the artist, are petroleum spirit and the benzenes, which comprise liquids of very varied degrees of volatility, and which do not share the objectionable propensity of oil of turpentine just alluded to. Here we would, however, remark that the petroleum hydrocarbons are much less efficient solvents than oil of turpentine, as they do not entirely dissolve even mastic or dammar; whilst, on the other hand, the benzenes are much superior in this respect, and especially the higher members of this series deserve the attention of the artist and varnish maker.

The last chapter in Part II. discusses varnishes and vehicles, their composition and preparation. Treating of mastic varnish—which is merely a solution of mastic in some volatile solvent, generally oil of turpentine—the author assigns to this substance its proper function, which is that of a surface varnish only. On no account

ought it ever to find its way into the body of the painting itself, as is unfortunately the case whenever megilp is used as the painting medium, this being in reality a mixture of mastic varnish with linseed oil. On the other hand, it is important that mastic varnish, when used as the surfacing varnish, should be applied without any admixture of oil varnishes, which, from their rendering the mastic harder, more insoluble, and less friable, make it much more difficult to remove and renew the varnish.

Of a different character and of far greater importance are the fat or oil varnishes, which are compounds of the harder resins, such as amber and the different kinds of copals, with linseed oil, and diluted with oil of turpentine. They form in reality the vehicle or medium for modern oil painting, and consequently furnish ultimately the matrix in which the particles of the colour are embedded and held together. Next to the stability of the colours, it is then the durability of this varnish medium in combination with dry linseed oil, on which the permanency of the oil-painting mainly depends. On the assumption that the valuable qualities of the hard resins are maintained in the varnishes derived from them, it is understood that artists' varnishes are prepared only from the hardest and most tenacious kinds of resins. Unfortunately these are the most unmanageable and the least soluble, and require the highest degree of heat to bring them into fusion for the purpose of effecting the combination with the linseed oil and oil of turpentine in the process of making varnish. Even the most powerful solvents, such as acetone, ether, benzene, chloroform, aniline, and phenol, have only a limited solvent action upon amber or the harder semi-fossil kinds of copal; and their solution can only be effected after they have undergone a profound change by fusion or otherwise. In opposition to what is generally stated, neither amber nor the semi-fossil hard copals are fusible in the ordinary sense of the word; for they require to be kept at a high temperature, in suitable vessels, for a considerable time before they become gradually liquefied by the action of the heavy oily products of their own decomposition. Amber or copal, when thus once melted, are completely changed; they are now fusible at a low temperature; they have become readily soluble in ordinary solvents, and miscible with heated linseed oil; but at the same time the original hardness of the resins is greatly reduced, and the colour has become of a more or less dark tint.

It remains to be proved whether much is gained by using the very hardest resins, instead of softer and more tractable kinds which yield lighter-coloured varnishes; and this is a subject which, in the reviewer's opinion, deserves investigation. Varnish-making is still a secret trade; and the nature of varnishes, more than any other artists' materials, is involved in much obscurity. There are no chemical methods known for ascertaining the nature or proportion of the ingredients used in their preparation, and as time is the most important factor in proving the quality of varnishes, direct practical experimental tests may be misleading.

A new process for making varnish, said to be in use on the Continent, consists in heating the resins with the solvents in autoclaves under high pressure; and there are also processes recommended which seem especially

adapted for those who wish to make their own varnishes on a small scale. These latter depend on the peculiar change which the hard copals undergo when exposed for some time, in a state of very fine powder, to the action of hot air, whereby the resin is rendered more soluble without becoming much discoloured. The author describes such a process, in which the finely-powdered resin, after having been exposed for some time to the action of air at a temperature of 220° C., is first dissolved in chloroform, then mixed with oil of turpentine, and after the chloroform has been distilled off, the resulting solution is gradually incorporated with the drying linseed oil. Although 220° C. is repeatedly mentioned as the temperature to which the powdered resins have to be exposed, we venture to suggest that this must be a mistake. Neither amber nor the copals will endure this temperature for any time without melting and becoming of a dark brown colour, or otherwise decomposed.

On the other hand, the writer of this notice has found that the various kinds of copal, which, by exposure in a finely-powdered condition for some weeks to the action of hot air in a steam closet, have become readily soluble in chloroform or acetone, are nevertheless almost entirely precipitated again on adding oil of turpentine or benzene to such a solution, and no amount of digestion, either with or without linseed oil, will redissolve them. Amber thus treated behaves in a similar manner, but the amount rendered soluble in chloroform or acetone is much smaller. It would, then, appear that this matter requires some further elucidation before this new process can be made readily available.

It has already been mentioned that there are no special tests for ascertaining the quality of a varnish. Spreading a thin layer on a sheet of glass, and then observing the character of the film produced on drying, seems all that can be done. It ought to become dry to the touch within eight or ten hours, and not become fissured even when exposed to sunshine during a year; nor should the surface become dull through the appearance of "bloom," caused by the minute exudation of solid fatty acids originating from the linseed oil employed in its preparation.

As the drying of the solution of resins in a volatile solvent depends solely on the volatilization of the solvent, this process is accompanied by a shrinkage of the body of the varnish, which sets up a tendency to breaking up of the surface. Linseed oil, on the other hand, becomes dry or solid in consequence of combining with a large quantity of oxygen, and this is attended by an increase in bulk. It follows that as long as a sufficient proportion of oil is in combination with the resin the tendency to crack is compensated; but if the artist, from habit or other reasons, uses with his colours a medium deficient in oil, he encounters the risk of the body of his paintings becoming fissured in the course of time, and readily subject to the destructive action of the atmosphere.

Part III. treats of pigments, and, as we might expect, this division forms a large and most important part of the work. All the colours which are made use of in painting are here described in detail, and nothing seems to be omitted which may serve to instruct or guide the artist and student. The historical reference with which the description of each of the colours is introduced is followed by

a discussion of its chemical composition, and an outline is given of the most approved methods of preparation. Wherever desirable the chemical test is described by which the purity of the colour may be recognized and any adulteration detected; but what will be esteemed as most valuable are the observations and suggestions which bear immediately upon the physical and chemical properties concerned in their special applications. Here the author gives us, in most cases, the results of his own experiments, and especially when he deals with the question of the permanency of the colours. The changes which the colours are liable to, whether under the influence of light, or when mixed with other colours, or under the conditions in which they exist in a painting, are likewise fully gone into and considered. Beginning with the white pigments, the author discusses the flake-white or white lead which occupies a foremost place on the artist's palette on account of its superior whiteness, its excellent working qualities, and the power it possesses of imparting its own strongly siccativ character to slow-drying oil colours. He also draws special attention to a valuable property of white lead which has scarcely been clearly recognized, and which depends upon the formation of a kind of lead-soap in the oil colours it is mixed with. This lead-soap imparts a degree of toughness and elasticity to the body of the painting, and thus prevents it from cracking when become dry with age. On the other hand, white lead, like all lead compounds, even when locked up in the medium of the paint, is liable to become brown and dark-coloured when exposed to the action of even minute traces of sulphuretted hydrogen, and this darkening is most favoured by moisture and the absence of light. According to the author, an admixture of baryta white (barium sulphate), in the proportion of one to two, very much lessens this deleterious effect. Zinc white, although free from the last-named defects of white lead, and of great value in water-colour, tempera, and fresco painting, has, nevertheless, only to a limited degree become a substitute for white lead in oil painting on account of its being a bad dryer, its possessing a lesser degree of opacity, and its tendency to crack and scale.

In the chapter on yellow pigments, the author's remarks on the peculiarities of the different shades of cadmium yellow deserve especial notice. We may here add, in passing, that any free sulphur in the raw cadmium yellow may be readily removed by carefully heating it in an open vessel. Aureolin, or cobalt yellow, is very favourably spoken of by the author, and so is baryta yellow and Indian yellow, but these have to be applied with caution when used along with certain other pigments to which he refers.

Very instructive are his observations on Naples yellow, an old favourite of the artist's; also those on yellow lake or brown pink, which, as he remarks, ought to be rigorously excluded from the artist's palette. The chrome yellows are dismissed with a very short notice, for, beautiful as they are, they are quite unfitted for use in tempera or water-colour painting, and although showing some degree of permanency when locked up in a resinous vehicle and protected by varnish, they are peculiarly liable to change when mixed with pigments of organic origin.

Passing on to the red pigments, we find a very full description of vermilion, a colour of great importance, but

unfortunately of a very capricious behaviour in respect of permanency. It is a remarkable fact that vermilion prepared from the native mineral cinnabar is found perfectly preserved in old Italian tempera paintings, and even in wall-paintings of Pompeii; whilst the artificial vermilion now generally in use, whether prepared by the dry or by the moist way, and although of finer tint and chemically pure, is very liable to change. All we know at present on this subject is that this is due not to a chemical alteration, but merely to a physical or molecular change of the red crystalline into the black modification of sulphide of mercury, and that this transformation is especially favoured by strong sunlight. Different samples of artificial vermilion, however, frequently exhibit a different degree of liability to change, and as the more finely ground orange vermilions are generally found to be the less stable, it has been inferred that the fine state of division favours the change. In reference to this we may, however, mention that if such pale vermilion is heated for some hours at a temperature approaching volatilization, it gradually assumes a darker red colour, and becomes crystalline like the sublimed cinnabar; and yet by this treatment its liability to turn black in sunlight is not lessened, but on the contrary much increased. It is evident that a great deal has still to be learned about this pigment.

The pigments derived from madder possess particular interest, and are remarkable for their stability as well as for their early introduction in the arts. The author states that such colours were known in Europe as early as the thirteenth century; but red madder pigments have been found in some quantity at Pompeii, and more recently also amongst ancient colour materials in Egypt.

Alizarin and its allied colouring principles, which are the essential colour-giving constituents originally derived from madder-root, are now manufactured artificially from anthracene, and most of the madder colours are at present obtained from this source. Nevertheless, it is a noteworthy fact that the choicer kinds of the madder pigments used by artists are still prepared from madder-root, although artificial alizarin, purpurin, and anthrapurpurin in a chemically pure state are accessible to the colour-maker at a cheaper rate. It is not clear whether it is merely habit of the colour-maker, and a difficulty of adapting the use of the pure colouring-matters to the old methods, or whether it is the presence of some still unrecognized constituent of madder-root, which causes the root to be preferred in the production of fine artists' colours. It is, perhaps, of interest to mention here that a difference in the behaviour of the artificial colouring-matter is also observed in the difficulty of applying it on wool or woollen cloth so thoroughly fast as to stand the operation of fulling. On this account the red cloth of the French army is still dyed with madder, and probably this is the true reason why the cultivation of this plant is still to some extent continued.

The study of the chemistry of the Turkey-red dyeing has fully established the important part which the presence of fatty matter, in some peculiar condition, plays in this remarkable process. That this also holds good with pigments can be shown by trying to produce these colours from artificial alizarins without using such fatty substances; and this may in some way account for the

author's failure to obtain the best possible result from pure alizarin, although prepared from madder-root.

Although madder colours are deservedly esteemed for their stability, the author has proved, by a series of experiments with different samples of commercial moist and cake colours, that they are by no means all alike in this respect. Considering their great importance for the artist, as being unique in their special qualities of tint and permanency, it appears highly desirable that a thorough investigation should settle the question as to the composition of the most stable of them, and thus furnish a guide to the preparation of entirely trustworthy colours. A formula quoted by the author on p. 154 for the preparation of madder carmine seems incomplete, as no mention is made of any alum or alumina, which is an essential constituent of this pigment.

Passing on, we take notice of a short account of lac dye and cochineal lakes, which, along with the ancient kermes, are furnished by three different species of coccus. Of these only the cochineal carmine is of interest; but, rich and beautiful as is this colour, the author very justly warns the artist against its use on account of its want of stability. We may take this opportunity of observing that pure carmine, notwithstanding its ready solubility in ammonia, is a true lake, and, in fact, is a definite compound of one of the carminic acids with lime and alumina.

In the chapter on blue pigments, the article on indigo deserves special attention; and many will be disappointed to find that this highly esteemed colouring-matter, generally supposed to be one of the most permanent, does certainly not deserve this character when used in painting. To this pigment is largely due the faded condition of the works of artists who have used it extensively. This proneness to fade is especially noticeable in water-colour paintings where the sulphindigotates have been employed.

Considering the lamentable deterioration of some of the works of artists who have used asphaltum too freely, it is satisfactory to learn that this substance may be safely employed if prepared as directed by the author. In this connection mention is also made of a brown water-colour said to be an ammoniacal extract of asphaltum; but we venture to say that this must be some trade mystification, for genuine asphaltum does not yield its colour to ammonia, or indeed to any other alkaline solvent.

After the detailed description of the pigments, a chemical classification of them is given, which in the main is an arrangement based upon their chemical composition, and which more prominently exhibits the characteristic chemical and physical difference of department of the various groups in which the pigments may be classified.

In chapter xxi. tables are given in which the pigments are ranged according to their stability into three classes, and it may be seen at a glance what degree of permanency is ascribed to any of them.

Chapter xxii. is full of most important considerations and useful suggestions with regard to selected and constructed palettes; and after discussing the lists of pigments used by some well-known artists, the author gives his selected palettes for oil and water colours.

In chapter xxiii. the chemistry of the various methods of painting in tempera, fresco, stereochromy, oil and water colour, and pastel, are discussed and explained;

and under oil painting the complicated changes which the vehicles and their constituents undergo during the process of painting are recapitulated.

Chapter xxiv. contains a study of old paintings and drawings, with the special object of giving a brief account of the materials used in the production of these early works, and comments on the lessons to be drawn from individual pictures.

Chapter xxv. is devoted to a discussion of the best means for conservation of pictures and drawings, with some useful hints on restoration; and in the concluding chapter xxvi. we have an account of trials of pigments as to their permanency, carried out by the author and other investigators. This is a subject which in recent times has received a good deal of attention, and although the investigations dealing with this matter are by no means concluded, very important results have already been obtained.

This is especially the case with regard to water-colour paints, which, on account of their thinness of application and absence of a protecting medium, are much more susceptible to fading, and therefore give greater facility for examination than the oil colours. It is now well understood that the action of light in conjunction with moisture and air is the principal cause of the fading of the colours; and were it practicable to keep water-colour drawings absolutely dry inclosed between glass plates, front and back, their preservation would be much prolonged. With oil paintings the conditions are different, and in some respects more favourable, especially when the painting has once reached its proper stage of maturity—that is to say, when the volatile vehicles have entirely passed away, and the linseed oil has completed its course of drying and oxidation. Whilst the process of drying is still going on in the early years of the existence of an oil painting, some amount of moisture is produced within the body of the painting as a direct product of the oxidation of the linseed oil, and consequently a picture too freely exposed to sunlight in this stage will be much more liable to suffer and to change than later on, when the resinous and oleaginous vehicles in which the particles of colour are locked up have become firm and quiescent. To fully appreciate this we must bear in mind that even the varnish and resinous vehicles do not so completely exclude air and moisture from without as is commonly supposed.

There is still much to be learned with regard to the chemical processes involved in the so-called drying of linseed oil, and this subject deserves a thorough re-investigation in the light and with the means of modern chemical research. It is, for instance, a well-known fact that linseed oil under certain conditions becomes itself a most powerful oxidizer, so much so that canvas or paper soaked with it will become destroyed in the course of time, and it seems that this effect is especially marked when oil of turpentine has been used along with it. It is quite conceivable that this activity of linseed oil may be one of the agents at work in the deterioration of oil paintings; but whatever dangers may arise from this, the use of linseed oil cannot be dispensed with. It is otherwise with oil of turpentine, for which a very much superior substitute might be found in the higher members of the benzene series, which could

now be obtained at a sufficiently moderate cost if a demand for them should arise. These hydrocarbons, whilst indifferent to the action of atmospheric oxygen, possess greater solvent power than any other, and on this account they are also well adapted for the preparation of varnishes. But for this latter purpose a still more suitable vehicle will be found in the amylic acetate, which dissolves even the hardest copals almost entirely after having been previously finely powdered and kept for some time in a hot closet. In this way excellent varnishes may be produced.

In reviewing a work dealing with so vast a number of subjects, it is obviously impracticable to do more than to refer to some few of them; but we think sufficient has been said in the foregoing notice to show the valuable character of the work before us, and although it will be freely admitted that there are still a good many points which demand further inquiry and elucidation, those who are interested in the subject may be congratulated on now possessing in an accessible form all that chemistry has for the present to say on paints and painting.

HUGO MÜLLER.

POINCARÉ'S THERMODYNAMICS.

*Thermodynamique.* Leçons professées . . . par H. Poincaré, Membre de l'Institut. Pp. xix., 432. (Paris : Georges Carré, 1892.)

THE great expectations with which, on account of the well-won fame of its Author, we took up this book have unfortunately not been realized. The main reason is not far to seek, and requires no lengthened exposition. Its nature will be obvious from the following examples.

The late Prof. W. H. Miller, as able a mathematician as he was a trustworthy experimenter, regularly commenced his course of Crystallography at Cambridge (after seizing the chalk and drawing a diagram on the black board) with the words:—"Gentlemen, let  $Ox, Oy, Oz$  be the coördinate axes." And, some forty years ago, in a certain mathematical circle at Cambridge, men were wont to deplore the necessity of introducing words *at all* in a physico-mathematical text-book:—the unattainable, though closely approachable, Ideal being regarded as a work devoid of aught but formulæ!

But one learns something in forty years, and accordingly the surviving members of that circle now take a very different view of the matter. They have been taught, alike by experience and by example, to regard mathematics, so far at least as physical inquiries are concerned, as a mere auxiliary to thought:—of a vastly higher order of difficulty, no doubt, than ordinary numerical calculations, but still to be regarded as of essentially the same kind. This is one of the great truths which were enforced by Faraday's splendid career.

And the consequence, in this country at least, has been that we find in the majority of the higher class of physical text-books few except the absolutely indispensable formulæ. Take, for instance, that profound yet homely and unpretentious work, Clerk-Maxwell's *Theory of Heat*. Even his great work, *Electricity*, though it seems to bristle with formulæ, contains but few which are altogether unnecessary. Compare it, in this respect, with the best of

more recent works on the same advanced portions of the subject.

In M. Poincaré's work, however, all this is changed. Over and over again, in the frankest manner (see, for instance, pp. xvi, 176), he confesses that he lays himself open to the charge of introducing unnecessary mathematics:—and there are many other places where, probably thinking such a confession would be too palpably superfluous, he does not feel constrained to make it. This feature of his work, at least, is sure to render it acceptable to one limited but imposing body, the *Examiners for the Mathematical Tripos (Part II.)*.

M. Poincaré not only ranks very high indeed among pure mathematicians but has done much excellent and singularly original work in applied mathematics:—all the more therefore should he be warned to bear in mind the words of Shakespeare

"Oh! it is excellent  
"To have a giant's strength; but it is tyrannous  
"To use it like a giant."

From the physical point of view, however, there is much more than this to be said. For mathematical analysis, like arithmetic, should never be appealed to in a physical inquiry till unaided thought has done its utmost. Then, and not till then, is the investigator in a position rightly to embody his difficulty in the language of symbols, with a clear understanding of what is demanded from their potent assistance. The violation of this rule is very frequent in M. Poincaré's work, and is one main cause of its quite unnecessary bulk. Solutions of important problems, which are avowedly imperfect because based on untenable hypotheses (see, for instance, §§ 284-286), are not useful to a student, even as a warning:—they are much more likely to create confusion, especially when a complete solution, based upon full experimental data and careful thought, can be immediately afterwards placed before him. If something is really desired, in addition to the complete solution of any problem, the proper course is to prefix to the complete treatment one or more exact solutions of simple cases. This course is almost certain to be useful to the student. The whole of M. Poincaré's work savours of the consciousness of mathematical power:—and exhibits a lavish, almost a reckless, use of it. Todhunter's favourite phrase, when one of his pupils happened to use processes more formidable than the subject required, was "Hm:—breaking a fly on the wheel!" He would have had frequent occasion to use it during a perusal of this volume. An excellent instance of the dangerous results of this lavish display of mathematical skill occurs at pp. 137-38, the greater part of which (*as printed*) consists of a mass of error of which no one, certainly, would accuse M. Poincaré. The cause must therefore be traced to the unnecessary display of dexterity with which, after obtaining the equation

$$Q_2/Q_1 = 1 - A/(T_1, T_2),$$

where the *order* of the suffixes is evidently of paramount importance, M. Poincaré proceeded to say "Nous pouvons donc écrire

$$Q_2/Q_1 = \phi(T_1, T_2)."$$

But his unfortunate printer, not prepared for such a *tour de force*, very naturally repeated the  $Q_2/Q_1$  of the first

equation, with the result of wholly falsifying all that follows. On the other hand, we must fully recognize that, when more formidable analysis is really required (as, for instance, in the treatment of v. Helmholtz's monocyclic and polycyclic systems), M. Poincaré seems to feel so thoroughly at home as to criticize with freedom.

One test of the soundness of an author, writing on Thermodynamics, is his treatment of temperature, and his introduction of absolute temperature. M. Poincaré gets over this part of his work very expeditiously. In § 15-17 temperature,  $t$ , is conventionally defined as in the Centigrade thermometer by means of the volume of a given quantity of mercury; or by any continuous function of that volume which increases along with it. Next (§ 22) absolute temperature,  $T$ , is defined, provisionally and with a caution, as  $273 + t$ ; from the (so-called) laws of Mariotte and Gay-Lussac. Then, finally (§ 118), absolute temperature is virtually defined afresh as the reciprocal of Carnot's function. [We say *virtually*, as we use the term in the sense defined by Thomson. M. Poincaré's *Fonction de Carnot* is a different thing.] But there seems to be no hint given as to the results of experiments made expressly to compare these two definitions. Nothing, for instance, in this connection at all events, is said about the long-continued early experimental work of Joule and Thomson, which justified them in basing the measurement of absolute temperature on Carnot's function.

In saying this, however, we must most explicitly disclaim any intention of charging M. Poincaré with even a trace of that sometimes merely invidious, sometimes purely Chauvinistic, spirit which has done so much to embitter discussions of the history of the subject. On the contrary, we consider that he gives far too little prominence to the really extraordinary merits of his own countryman Sadi Carnot. He writes not as a partisan but rather as one to whom the history of the subject is a matter of all but complete indifference. So far, in fact, does he carry this that the name of Mayer, which frequently occurs, seems to be spelled incorrectly on by far the greater number of these occasions! He makes, however, one very striking historical statement (§ 95):—

"Clausius . . . lui donna le nom de *Principe de Carnot*, 'bien qu'il l'eût énoncé sans avoir connaissance des 'travaux de Sadi Carnot.'"

Still, one naturally expects to find, in a Treatise such as this, some little allusion at least to Thermodynamic Motivity; to its waste, the Dissipation of Energy; and to the rest of those important early results of Sir W. Thomson, which have had such immense influence on the development of the subject. We look in vain for any mention of Rankine or of his Thermodynamic Function; though we have enough, and to spare, of it under its later *alias* of Entropy. The word dissipation does indeed occur, for we are told in the Introduction that the *Principe de Carnot* is "*la dissipation de l'entropie*."

We find Bunsen and Mousson cited, with regard to the effect of pressure upon melting points, almost before a word is said of James Thomson; and, when that word does come, it wholly fails to exhibit the real nature or value of the great advance he made.

Andrews again, à propos of the critical point, and his splendid work on the isothermals of carbonic acid, comes

in for the barest mention only *after* a long discussion of those very curves, and of the equations suggested for them by Van der Waals, Clausius, and Sarrau:—though his work was the acknowledged origin of their attempts.

The reason for all this is, as before hinted, that M. Poincaré has, in this work, chosen to play almost exclusively the part of the pure technical analyst; instead of that of the profound thinker, though he is perfectly competent to do that also when he pleases. And, in his assumed capacity, he quite naturally looks with indifference, if not with absolute contempt, on the work of the lowly experimenter. Yet, in strange contradiction to this, and still more in contradiction to his ascription of the Conservation of Energy to Mayer, he says of that principle:—"personne n'ignore que c'est un fait expérimental."

Even the elaborate thermo-electric experiments of Sir W. Thomson, Magnus, &c., are altogether ignored. What else can we gather from passages like the following?

(§ 287) "Sir W. Thomson admet qu'il existe une 'force électromotrice au contact de deux portions d'un 'même conducteur à des températures différentes; il 'assimile donc ces deux portions à deux conducteurs 'de nature différente, assimilation qui paraît très vraie-semblable."

(§ 291) ". . . si l'effet Thomson a pu être mis en 'évidence par l'expérience, on n'a pu jusqu'ici constater 'l'existence des forces électromotrices qui lui donnent 'naissance."

Everyone who comes to this work of M. Poincaré fresh from the study of Clerk-Maxwell's little treatise (or of the early papers of Thomson, to which it owed much) will feel as if transferred to a totally new world. Let him look, for instance, at Maxwell's treatment of the Thermodynamic Relations, Intrinsic and Available Energy, &c., and then turn to pp. 148-150 of M. Poincaré's work. There he will find at least a large portion of these most important matters embodied in what it seems we are now to call the *Fonctions caractéristiques de M. Massieu!*

But the most unsatisfactory part of the whole work is, it seems to us, the entire ignorance of the true (*i.e.* the statistical) basis of the second Law of Thermodynamics. According to Clerk-Maxwell (NATURE, xvii. 278)

"The touch-stone of a treatise on Thermodynamics is 'what is called the second law.'"

We need not quote the very clear statement which follows this, as it is probably accessible to all our readers. It certainly has not much resemblance to what will be found on the point in M. Poincaré's work:—so little, indeed, that if we were to judge by these two writings alone it would appear that, with the exception of the portion treated in the recent investigations of v. Helmholtz, the science had been retrograding, certainly not advancing, for the last twenty years. P. G. T.

#### INSECT PESTS.

*Hand-book of the Destructive Insects of Victoria.* By C. French, F.L.S., Government Entomologist. Part I. Prepared by Order of the Victorian Department of Agriculture. (Melbourne, 1891.)

THE appearance of this volume affords another proof, if any were required, of the wholesome activity, now noticeable in all progressive countries, directed



towards the suppression of the insect pests of cultivated plants. One effect of this welcome energy has been a process of differentiation, whereby the attacks of insects upon crops, instead of being included in the comprehensive but somewhat incomprehensible term of "blight," have been separated one from another, more or less clearly defined, and, to a very useful extent, associated respectively with the ravages of certain specific insects. It is now possible for those to whom the subject is new to obtain a much clearer idea of the scope of agricultural entomology than was the case even as recently as five or six years ago. "The time has arrived," observes the author, "when, if we are to fight insect pests successfully, united action must be taken, and knowledge gained by constant vigilance, and by useful and carefully conducted experiments. Only thus can a better knowledge be obtained of the relations of insects to agriculture, viticulture, and horticulture."

About one-fifth of this volume of 150 pages is devoted to an introduction to entomology, a classification of insects, directions for collecting and preserving specimens of economic interest, the preservation of insect-destroying birds, and certain horticultural quarantine rules. The main part of the book is occupied with a discussion of fourteen of the most troublesome insect pests of apples, pears, apricots, and cherries in the colony of Victoria. These are illustrated by means of coloured plates, the excellence of which demands a word of approbation. The ever-growing facilities for international transport are, no doubt, partly responsible for the extent to which the insect pests of this country are identical with those of the Antipodes. In this connection it is worthy of note that at least five of the pests which are illustrated have acquired as unenviable a reputation in Britain as in Victoria. These are the woolly Aphis (or American blight), the codlin moth, the apple-bark scale, the red spider (an Arachnid), and the pear and cherry slug, which is the slimy, repulsive-looking, leaf-eating larva of one of the saw-flies. Of the fourteen pests enumerated, the Lepidoptera claim four, Coleoptera three, Homoptera two, Heteroptera two, Arachnoidea two, and Hymenoptera one.

The volume concludes with an instructive chapter upon insecticides and the means for applying them. Amongst the more noteworthy of the former are carbon bisulphide, Gishurst compound, hellebore powder, kerosene (petroleum), gas lime, London purple, Paris green, sulphur, and tobacco. A caution is given as to the use of certain so-called insecticides, such as ammonia and carbolic acid. Insecticides they undoubtedly are, but inasmuch as they injure the plant as well as kill its pests, they had better be left alone. Various kinds of apparatus for applying insecticides are described, and illustrated by means of twenty wood-cuts. The most efficient and one of the newest of these, the air-power distributor called the Strawsonier—after its inventor, Mr. G. F. Strawson, an Englishman,—is adequately described and figured. Several useful nozzles and pumps are likewise noticed.

Mr. French has produced a volume of much practical value, and it may be hoped that he will maintain the same high standard in the subsequent parts. One appeal, however, may be made to the author—and not only to him but to all writers upon this subject,—and that is to append the name of the authority to the systematic name of each

insect. Agricultural entomology is necessarily a subject of international interest, and much confusion arises—especially in connection with American writings—through an omission which might easily be remedied. The difficulties of synonymy are great enough, without gratuitously adding to them.

#### OUR BOOK SHELF.

*Farm Crops.* By John Wrightson, M.R.A.C., F.C.S. (London: Cassell and Company, Limited, 1891.)

THE author introduces this volume of upwards of 200 pages as "an honest attempt to place the large subject of crop cultivation before the minds of children"; and this, reasonably enough, his plea for its being "penned in the plainest possible language." The work belongs to "Cassell's Agricultural Readers," and the several chapters deal with rotations of crops, the fallow, root crops, corn crops, grass crops, grasses, clovers and pasture plants, and the making and management of pastures.

Whether agriculture is a subject that can be at all satisfactorily treated, in a book of the type which a "reader" necessarily suggests, is a question that need not be discussed here. But it is abundantly evident that the problem has not been solved in the volume under notice. It is sprinkled with footnotes and tables, the latter being of as complicated a character as any which are usually found in agricultural treatises. Then, again, there are long quantitative lists of grass seeds recommended for use in laying land down to pasture, and these, it is to be feared, will be found both wearisome and unintelligible to the small boy who has to wade through them in the course of a "reading lesson." Indeed, the book is curiously unequal throughout, and it is apparent that the author would probably have done better had he not had to continually remind himself that he was writing a "reader" for children.

It is particularly desirable that, in a strictly elementary book, everything should be correct; but this is hardly the case with some of the illustrations. In Fig. 2, for example, the fruit of the cabbage is represented as dehiscent from above downwards, though this is not the behaviour of a silique in nature. On the other hand, the figures of grasses are exceedingly good.

The text is not free from errors. On p. 67 is described what will happen "if turnips braid (*sic*) too thickly." The use of systematic names will rather hinder the juvenile student than otherwise, unless special care is taken to render them correctly, which is not always the case. Occasionally, the fanciful element is in evidence, as when it is stated (p. 207): "Mowing is as old as Time itself; for has not Time been represented as carrying a scythe over his shoulder?"

"In future editions," it is said in the preface, "this little book may, no doubt, be further extended." It is questionable, however, whether the author would not more successfully meet the requirements of a "reader," of the kind which appears to be contemplated, by eliminating all such matters as do not fall easily into the course of a reading lesson. At present, it would seem as if the object had been to produce a "text-book" rather than a "reader."

*Arithmetic for Schools.* By Charles Smith. "Pitt Press Mathematical Series." (Cambridge: University Press, 1891.)

MR. CHARLES SMITH is such a well-known writer of mathematical works that we expected to find the present volume very commendable. In this we are not disappointed. The explanations of the fundamental principles

and processes are treated with a clearness, conciseness and completeness that make the book a delight to read; and although, as he says, "my aim has not been to introduce novelties," yet he has succeeded, in so far as we are able to predict, in placing before students a book not only of practical utility, but also of great educational value.

Stocks and shares, and such like transactions, have all been treated more in accordance with the methods of the present day than is usual in such treatises. There has also been inserted a chapter on foreign exchanges for the benefit of those preparing for examinations in commercial arithmetic. The examples are of a varied and useful nature, and are numerous and well chosen: each new principle or process is accompanied with one or two sets of them, while interpolated throughout are many to be worked out by those who wish to revise their back work as they proceed in the subject. Miscellaneous exercises to the number of 500, together with sets of examination papers, form also a useful addendum. W.

*Journeys in Persia and Kurdistan.* By Mrs. Bishop (Isabella L. Bird). Two Vols. With Portrait, Map, and Illustrations. (London: John Murray, 1891.)

THIS work consists of letters written in the course of the second half of journeys in the East which extended over a period of two years. The author had intended, in the event of their being published, to correct them by reference to notes made with much care. Of these notes she was robbed, and she refers to the loss as her "apology to the reader for errors which, without this misfortune, would not have occurred." Perhaps, however, the book is all the better for being presented essentially in the form in which it was originally written. The record of the writer's impressions has thus a directness, simplicity, and freshness of which it might to some extent have been deprived by elaborate revision. Mrs. Bishop does not profess to have written a book on Persia and Eastern Asia Minor. She has merely set down what she herself saw during her travels in those countries. But she has done this so well that ordinary readers are not likely to resent the slightness of her references to the administration of government, the religious and legal systems, the tenure of land, and the mode of taxation. The illustrations are very good, and add considerably to the interest of the narrative.

*A First Book of Electricity and Magnetism.* By W. Perren Maycock, M.Inst.E.E. (London: Whittaker and Co., 1891.)

THE scope of this work is limited to the syllabus of the elementary stage of the Science and Art Department. It is intended as an easy introduction to many of the text-books now in use, which, although termed elementary, are of rather too advanced a nature for some students to commence with; the author considering that they might be led to "take a greater interest in their work" by the help of such a book as he has put before us.

Throughout the three parts, which deal severally with magnetism, electro-kinetics, and electro-statics, the explanations are of a plain and simple nature, while the illustrations bring out clearly the various points which they are intended to exhibit. The information is based on the latest ideas; and interpolated in the text are many questions, the answers to which the student should write out before proceeding beyond them.

The book will be found really very useful for beginners, and will be to them a good introduction to higher works.

*A Cyclopædia of Nature Teachings.* With an Introduction, by Hugh Macmillan, LL.D., F.R.S.E. (London: Elliot Stock, 1892.)

THE compiler of this volume has brought together a large number of extracts from various authors, setting forth

what profess to be "facts, observations, suggestions, illustrations, examples, and illustrative hints taken from all departments of inanimate nature." Here is the information offered to us about "the sun-controlled stars":—

"When stars, first created, start forth upon their vast circuits, not knowing their way, if they were conscious and sentient, they might feel hopeless of maintaining their revolutions and orbits, and might despair in the face of coming ages. But, without hands or arms, the sun holds them. Without cords or bands, the solar king drives them unharnessed on their mighty rounds without a single misstep, and will bring them in the end to their bound, without a single wanderer."

This sorry stuff is a fair specimen of a good many of the "Nature Teachings" presented in the "Cyclopædia." A more suitable title for the compilation would have been "Scientific Gush." The compiler does not always even give accurate titles to his extracts. A passage from one of Mr. Ruskin's writings has the strange heading, "The Star Mercury."

#### LETTERS TO THE EDITOR.

[The Editor does not hold himself responsible for opinions expressed by his correspondents. Neither can he undertake to return, or to correspond with the writers of, rejected manuscripts intended for this or any other part of NATURE. No notice is taken of anonymous communications.]

#### On the Attitudes of the Zebra during Sleep, and their Influence on the Protective Value of its Stripes.

NOWADAYS, when the colours of animals and their uses for the purposes of recognition and protection are forcing themselves upon the attention of all naturalists, it is not wonderful that an animal so conspicuously marked as the zebra should have commanded a large share of notice.

Much as it has been considered, however, I do not think we have yet learned all the lessons that it has to teach us.

That its bold and vivid stripes should be of immense service for recognition may be accepted as beyond dispute.

The statement of Mr. Francis Galton, that on a clear moonlight night these vivid stripes melt into invisibility, and to an eye not absolutely focussed to the animal itself, but to objects in its immediate vicinity, it is quite unseen, even when so near that its breathing can be heard distinctly, proves most indubitably their immense protective value. As he says, "If the black stripes were more numerous, it would be seen as a black mass; if white, then as a white one; but their protection is such as exactly to match the pale tint which arid ground possesses in the moonlight."

*Primo facie*, this is hardly what one would have expected, but when pointed out by a competent and trustworthy observer, even a slight knowledge of the laws of light proves it to be true.

Let anyone notice at what a short distance a lady in a *galatea* dress with broad stripes becomes invisible in the moonlight, and he will be at once convinced of the truth of Galton's remark.

Prof. Henry Drummond further says:—"When we look at the coat of a zebra, with its thunder-and-lightning pattern of black and white stripes, we should think such a conspicuous object designed to court, rather than elude, attention. But the effect in nature is just the opposite. The black and white somehow take away the sense of a solid body altogether, and the two colours seem to blend into the most inconspicuous grey, and at close quarters the effect is as of bars of light seen through the branches of shrubs. I have found myself in a forest gazing at what I supposed to be a solitary zebra, its presence betrayed by some motion due to my approach, and suddenly realized that I was surrounded by an entire herd, which was all invisible until they moved." By this I understand Prof. Drummond to refer to his observations in the day-time, as Mr. Galton speaks only of the moonlight.

One can readily see how the shadows of the branches in a tropical forest falling upon the zebras would so intermingle with the stripes of the animals as to add enormously to the difficulty of recognition by human eyes, and also, in the dim light of the

forest (broken up as it is into bars of light and shade), by the eyes of their fierce and hungry foes as well.

A careful examination of the varied stripes of the zebra has forced upon my mind the conviction that they have a still deeper meaning and value than has hitherto been noticed and explained.

It is easy to see how the vertical bars may assimilate to the falling shadows in the noonday sun, and the diagonal stripes on the neck and hind-quarters to those cast by the declining day. But it is not so much in the day-time and during its waking hours that the zebra stands in such pressing need of concealment as at night, when it is compelled to rest. Then, when surrounded by eager and wakeful foes, it *does* require all the concealment it can get. Now, let us suppose the animal to be lying down, say partly on its side and partly on its belly, as horses very frequently do. What will be the effect of such an attitude upon the different stripes on various parts of the body? In the first place, the animal will thrust out its knees, and fold its fetlocks backwards under its body in such a manner that the horizontal bars on the fore-legs will become vertical.

At the same time it will push out in a backward direction, its haunches, and the hind-feet will be brought forward under or near its body, so that the diagonal stripes on the hind-quarters will be drawn so as to become much more vertical, and to correspond with the now vertical bars across the hind-legs, made vertical by the folded position of the limbs. In such an attitude—a perfectly natural and common one—all the stripes of the body will be vertical, or nearly so, especially if the zebra rests its head upon the ground, or its fore-legs, so as to bring the diagonal stripes of its neck into unison with all the rest. Supposing, then, that a coincidence in the general direction of the stripes is produced by such an attitude of the body during rest, is it too much to assume it to be an extension and refinement of those protective devices of Nature, extending to the sleeping zebra the full amount of all the possible protective value of its stripes just at the very time when it needs it most, so that in the clear tropical moonlight, when the shadows are only a little less distinct than in the day, it may be able to repose in something like safety and peace?

But, suppose the zebra rests, not always on its belly, as suggested, but now and then on its side, with its limbs outstretched. It is plain that the vertical, diagonal, and horizontal stripes would then be all more horizontal than anything else, but pointing in different directions, and would then so assimilate themselves with the crossed and varying directions of the shadows as to have the same practical effect in hiding the sleeping animal from its foes.

Under such a supposition (by no means an impossible one), it seems to me that those beautiful bars of brown and white surround the dormant zebra with a protection and a defence almost as secure as bars of iron or brass, leaving the foes with nothing but their sense of smell to guide them to their prey.

We have only to assume the folding up of the limbs, like the folding up of a two-foot rule, until the marks on both sides correspond, and we see at once the unification in the general direction of all the stripes of the body, which I cannot help believing has a very considerable protective value to the zebra.

However, if any enlightened and generous patron of science would kindly present to our College ("Owens," Manchester) a good stuffed specimen of a recumbent zebra in the attitude I have suggested, he would help considerably to settle a nice point in the matter of protective colouring, and give to the cause of scientific education a very welcome and appreciable aid.

December 21, 1891.

H. W.

### The Migration of the Lemming.

THERE are two questions which I should like to ask Mr. W. Dappa-Crotch touching his recent letter on the above subject (*NATURE*, December 31, p. 199); and for this purpose I had better begin by quoting a paragraph from my own discussion of the same subject, written close upon ten years ago:—

"Looking to Mr. Collett's large experience on the subject, as well as to the intrinsically probable nature of his views, I think we may most safely lend countenance to the latter. The most important point of difference between Mr. Crotch and Mr. Collett has reference to a question of fact. For while Mr. Crotch states that the migrations are made westwards without reference to the declivities of the country, Mr. Collett is emphatic in saying that 'the wanderings take place in the direc-

tion of the valleys, and therefore can branch out from the plateaux in any direction.' If this is so, there is an end of Mr. Crotch's theory, and the only difficulty left to explain would be why, when the lemmings reach the sea, they still continue on their onward course to perish in their multitudes by drowning. The answer to this, however, is not far to seek. For their ordinary habits are such that when in their wanderings they come upon a stream or lake, they swim across it; and therefore when they come upon the coast line it is not surprising that they should behave in a similar manner, and, mistaking the sea for a large lake, swim persistently away from land with the view to reaching the opposite shore, till they succumb to fatigue and the waves. Therefore, pending further observations on the question of fact above alluded to, I cannot feel that the migration of the lemming furnishes any difficulty to the theory of evolution over and above that which is furnished by the larger and more important case of migration in general, to the consideration of which I shall now proceed" ("Mental Evolution in Animals," pp. 284-85).

Mr. Dappa-Crotch's theory thus alluded to—which constituted the most striking feature of his "rather lengthy paper before the Linnean Society," and which, he then wrote, "led me to spend two years in the Canaries and adjacent islands"—is, briefly, as follows:—

"I allude to the island or continent of Atlantis. . . . It is evident that land did exist in the North Atlantic Ocean at no very distant date. . . . Is it not then conceivable, and even probable, that, when a great part of Europe was submerged, and dry land connected Norway and Greenland, the lemmings acquired the habit of migrating westwards, for the same reasons which govern more familiar migrations? . . . It appears to me quite as likely that the impetus of migration towards this continent should be retained, as that a dog should turn round before lying down on a rug, merely because his ancestors found it necessary thus to hollow out a couch in the long grass" (*Linn. Soc. Journ.*, vol. xiii. p. 30).

And, in a subsequent paper (*ibid.*, p. 157 *et seq.*), he combats the statement of Mr. Collett, "that these migrations follow the natural declivities of the country." Now, however, it appears that Mr. Collett turns out to be right as to the fundamental fact of the migrations not being westerly more than towards any other point of the compass; for Mr. Dappa-Crotch, in his letter to you, acknowledges that, in regard to this point, which he previously maintained against Mr. Collett, he "was betrayed into an error by trusting to common report and insufficient personal experience." Nevertheless, he still maintains that the lemmings in their migrations "do not follow the water-shed."

The questions, therefore, which I have to put are: (1) What are the grounds on which Mr. Dappa-Crotch continues to differ from Mr. Collett touching this minor point? and (2) Does he still maintain his theory with regard to "the island or continent of Atlantis," since he has found himself in error upon the major point?

GEORGE J. ROMANES.

Christ Church, Oxford, January 6.

### Destruction of Immature Sea Fish.

IT might be supposed that the "importance of the subject" would have induced Mr. Walker, at all events, to examine Dr. Fulton's observations at first hand, before criticizing them (*NATURE*, December 24, 1891, p. 176), instead of confining himself to reading a review.

It may be pointed out that Dr. Fulton's computation of the number of young fish captured is intended to apply only to the Solway, as indeed may be gathered from your review, and being, not a matter of hearsay, as implied by Mr. Walker, but founded on an average of fifteen hauls extending over nine months of the year, is likely to be pretty near the mark.

In examining Mr. Walker's own computation, we find that he reckons six days' fishing to the week, instead of four, which is Dr. Fulton's estimate, based on local inquiry; and we may say that, if Mr. Walker has succeeded in utilizing every working day during any one year of his trawling career, he must have been singularly fortunate in his weather, or must have confined himself to very sheltered waters. I think it will be conceded that a calculation derived from actually counting the catch is more trustworthy than one derived from an observation (or was it only an estimate?) of weight. If, however, "10 cwt. of young flukes, . . . not one the size of half-a-crown," is really only the

sixtieth part of a day's destruction in the Formby Channel, it is a wonder that there are any left.

A point emphasized in the review, but seemingly missed by Mr. Walker, is that the young fish are always promptly returned to the sea by the Solway shrimpers, and the fact that the industry flourishes in spite of the delay so caused shows that the destruction which ensues from the practices described by Mr. Walker is quite unnecessary. Dr. Fulton has experimentally proved that the proportion of young flat-fish of a certain size (say above an inch) that would not survive if returned to the sea is small, so that it is evident that Mr. Ascroft's "axiom that 90 per cent. of fish that come on board a boat is destroyed" holds good from no fault of the trawl itself, but simply from a discreditable carelessness on the part of the man.

Mr. Walker's experiences at the mouth of the Dee show that the shrimps and the young soles (species?) have different habitats in that river, so that his suggestions as to the limitation of shrimp-trawling seem rather superfluous, since it may be supposed that the trawler would fish where he knew he could get shrimps, and not go out of his way to catch what he did not want. I have noticed myself on the west coast of Ireland that the minute post-larval flat-fish, smaller than those dealt with by Fulton, and which are undoubtedly killed by the meshes of the shrimp-trawl, were never taken on ground frequented by shrimps, where, indeed, as one may judge from the relations of the two forms in captivity, the weaker would have a poor chance of surviving.

Everyone will agree with Mr. Walker that it is most necessary to ascertain the habitat of the young fish at different times of the year, and to this end the energies of the Marine Biological Association in England, the Fishery Board in Scotland, and the Royal Dublin Society in Ireland, have been for some time directed; and the assistance that might be rendered by a series of observations by one possessing the experience and opportunities of Mr. Walker would be incalculable. Until, however, our knowledge on the subject is much more complete, I question the advantage of strewing boulders about the bottom of the sea. Even if they remained to accomplish their purpose of interfering with trawling, there is the danger that they would form an attractive shelter, not to the young flat-fish that stand in no need of it, but to some of their natural enemies.

Dublin, December 27, 1891.

ERNEST W. L. HOLT.

### A New Precessional Globe.

To facilitate the understanding of the effects of precession, I have made a new arrangement of the celestial globe. A globe mounted in the new way can give a representation of the starry heavens for every place on the earth, and for any date, both past and future.

The globe is fastened in a ring, so that it can be turned round an axis that goes through the poles of the ecliptic, but can also be fixed in any position by a pair of screws. The amount of turning is to be measured by a divided circle.

The ring above mentioned—which we will call ring I.—is movable in another ring (ring II.), round an axis, which forms a right angle with the axis formerly mentioned. The inclination between ring I. and ring II. can be measured by an index; it must equal the obliquity of the ecliptic.

Ring II. is fastened finally in a third and extreme ring (ring III.), so that it can be turned round an axis which forms an angle of 90° with the axis of ring II. Ring III. is mounted on a stand with a horizon-circle, so that its axis can be inclined at pleasure to the plane of the horizon-circle. The inclination may be read on a scale engraved on ring III.

To adjust the apparatus to show the firmament at any appointed place and time, one must place ring III. so that its inclination towards the horizon-circle equals the latitude of the place. Then ring II. must be turned so that its plane coincides with the plane of ring III. The angle between I. and II. must be equal to the obliquity of the ecliptic at the appointed time. Finally, the globe must be turned round the axis which goes through the poles of the ecliptic, till the point of the heaven, which is the celestial pole for the time appointed, comes under the axis round which ring II. turns in ring III. If the globe is then fastened in ring I., and ring I. in ring II., with screws, by turning the globe in ring III. one can see at a glance which stars are setting and rising, and which are always above the horizon.

By making Vega, for example, the celestial pole (14,000 A.D.),

one can see immediately that for the latitude of London at that remote period, the Cross would be seen at the southern horizon, and that Sirius then did not rise at all. K. HAAS.  
Vienna.

### Simple Proof of Euclid II. 9 and 10.

IN NATURE of December 24 (p. 189) a simple proof of Euclid II. 9 and 10 is given, which it is stated is believed to be new. It may therefore be of interest to your readers to know that these proofs are given in an edition of Euclid which we have now in the press. As the author, Mr. Brent, is resident at Dunedin, New Zealand, we are unable to state whether he lays claim or not to any originality in respect to them; in any case, as he has been engaged in mathematical teaching for many years, these and similar proofs of other propositions in Euclid II. have clearly been more widely employed than has been supposed.

PERCIVAL AND CO.

34 King Street, Covent Garden, London, January 4.

### THE ALLEGED DISCOVERY OF A BACILLUS IN INFLUENZA.

FROM the behaviour of influenza as an epidemic, it seems not unreasonable to suppose that it may have as its cause a living and multiplying organism; and when influenza reappeared, after an interval of many years, in the latter part of 1889, and more especially since its communicability from person to person, formerly disputed, has come to be generally admitted, the public mind, medical and lay, has been in expectation of the announcement that a specific microbe had been discovered as the cause of the disease.

Even in diseases, however, of which the characters point most strongly to a parasitic microbe as their cause, the discovery of such an organism is by no means an easy matter. Thus, no micro-organism has as yet been identified as the cause of small-pox, although this disease is always more or less with us; breeds true; has distinct characters, and a definite localization on the skin; and propagates by a contagion which retains its activity for very long periods—circumstances which point to a specific organism as its cause, and might be thought to facilitate its discovery.

From *a priori* considerations we must suppose the properties of the hypothetical influenza microbe to be as follows. The diffusibility of the poison through the air shows that it must be very minute and readily suspended. For the same reason it must belong to the class of aerobic organisms, *i.e.* those for whose existence oxygen is necessary, or at any rate not hurtful. It must multiply with extreme rapidity. It must be capable of multiplying in the bodies, or secretions, of human beings; and probably also in some medium or media outside the human body—perhaps on damp ground-surfaces, or in confined air laden with dust and organic matter. One can hardly suppose it capable of multiplying in pure air, as it would lack pabulum; perhaps, as Dr. Symes Thompson suggests, particles of organic dust floating in the air may serve as rafts for it to live on. As, however, influenza prevails under the most opposite conditions of season, climate, and weather, our supposed microbe, if it can live in the air, must be able to flourish under a great range of temperatures and degrees of humidity. I am not aware of any instances of long retention of contagion, such as would lead us to postulate the possession by our microbe of resting spores. From these considerations we might have expected that it would be more likely to turn out to be a micrococcus than a bacillus.

From what is known of the pathology of some other diseases of microbic origin, as tetanus and diphtheria, it seems possible that the immediate cause of the symptoms of influenza may be the presence in the blood and tissues, not of the microbe itself, but of the poison

manufactured by it. The microbe itself may disappear early in the case; but the poison formed by it pervades the whole body, and especially the nervous system, and produces profound and lasting effects. An early disappearance of the microbe in influenza would explain the failure to find it on *post-mortem* examination; death from influenza being usually the result of complications rather than of the primary disease. Influenza is infectious at an early stage of the disease; but it is not known how long the infectious condition may last: some cases point to its being infectious as late as the eighth day, and we must suppose that, as long as the disease is communicable, the microbe retains its vitality.

Evidently there is a power of resistance in the human body to the invasion of the microbe, varying in different persons, for not all who are exposed to the infection contract the disease; and the resistance to it being weakened by depressing influences—as fatigue, and exposure to changes of temperature.

The resistance to the poison seems also to be overcome when the dose is large: a certain degree of concentration seems to be necessary in order for the disease to take on an epidemic form.

The pabulum for the microbe, or the number of susceptible persons, seems also to be soon exhausted; for the decline of an epidemic as regards the number of new cases is often almost as rapid as its increase. At the same time the immunity conferred by an attack of influenza is of short duration, for a person may suffer repeatedly from the disease; and the same holds as regards communities, for many localities have suffered repeated epidemics of influenza during the last few years; whereas an epidemic of one of the ordinary infectious diseases is usually succeeded by a long period of comparative freedom. These are some of the points which have to be taken account of in any theory of the causation of influenza.

During the past week the announcement has been made in the public press of the discovery by Dr. Pfeiffer, in the Royal Institute for Infectious Diseases at Berlin, of a bacillus which he looks upon as the cause of influenza.

It will be remembered that a similar announcement, made, in January 1890, by Dr. Jölles, of Vienna, was not confirmed. Since then various observers have discovered in the sputa and lungs of influenza patients, micro-organisms of one kind or another; but their statements are conflicting, and the forms met with are some of them at least known to occur in other diseases; so that the inference is that they were either accidentally present, or connected with secondary affections for which the attack of influenza had prepared the way. Whether Dr. Pfeiffer's discovery will be more successful in gaining acceptance remains to be seen; but the position of its author, and the alleged confirmation of his results by Dr. Koch, will no doubt secure for it a respectful consideration.

As Dr. Koch has pointed out, in order that the relation of a particular micro-organism to a particular disease, as cause and effect, may be considered satisfactorily proved, the following conditions must be complied with:—

- (1) The micro-organism in question must be present in the secretions, blood, or diseased tissues of the subject of the disease.
- (2) The micro-organisms in question must be isolated and cultivated—all other organisms being excluded—in suitable media outside the animal body, through several generations of cultures.
- (3) The micro-organisms, thus cultivated, when introduced into the body of a healthy animal of a susceptible kind must be capable of producing in it the disease in question.
- (4) In the animal in which the disease has thus been produced the same micro-organism must again be found.

It is stated that, for the investigation of the etiology of influenza, a *clinique* for influenza patients was opened in

September last in the Royal Institute for Infectious Diseases, and that the result of the exhaustive examination of the cases was the discovery in the matter discharged from the patients' lungs of a bacillus found in no other cases of disease of the respiratory organs, and which, as the patient recovered, gradually disappeared. It is stated that the bacilli were cultivated to the fifth generation, and that, inoculated into monkeys and rabbits, they produced in every case the symptoms of influenza.

It is added that these results were confirmed by Dr. Koch, who further discovered the same bacillus in the blood of patients in the febrile stage of influenza.

An account of the discovery is promised in the *Deutsche medicinische Wochenschrift*, and will be awaited with interest.  
H. F. P.

ON THE MATTER THROWN UP DURING THE SUBMARINE ERUPTION NORTH-WEST OF PANTELLERIA, OCTOBER 1891.

WE did not reach Pantelleria till November 5, ten days after the end of the eruption, but a certain number of specimens had been secured at the time by people who went out in boats. Dr. Errera, who helped us in other ways, kindly gave me some pieces of a bomb from his own collection; and others, among them a good-sized bomb, some 30 inches in its longest diameter, were obtained from the inhabitants. Out of a number of small pieces from different people, I did not see any that might not have formed some part of a mass such as this last, and I have no evidence that any other kind of material was erupted.

*General, Structural, and Mineralogical Characters.*

Riccò (*Comptes rendus*, November 25, 1891) says that some of the bombs had a diameter of 2 metres, and that the prevailing shape was an "ellipsoid of revolution." They were not only porous in texture, but contained large cavities, and floated for a time, but pieces taken separately are fairly heavy. Riccò mentions a specific gravity of 1.4 (perhaps for a bomb when unbroken). A 4-ounce piece of the coarser material from the inside displaced less than half its weight of water, giving me specific gravity 2.3.

What most struck the possessors of specimens was their coaly blackness. Nevertheless, there was on the outside of the bombs a distinctly brownish layer, an inch perhaps in thickness, which the eye, or better, the pocket lens, shows to be due to vesiculation of the transparent brown glass that here forms the ground mass. In certain places vesiculation has been carried so far that we have a *coarse*<sup>1</sup> type of the "thread lace scoria," described among others by Dana, from Hawaii (*Amer Journ. Sci.*, March 1888, p. 213, or his book, "Characteristics of Volcanoes," p. 163, 1890).

In the brown glass of this part sections show numerous narrow crystals of triclinic feldspar, and in places olivine and magnetite, and probably a little augite.

Beneath this brownish layer may occur another, say half an inch thick, coarser and darker than the former; but which in sections can still be seen to be for the most part brown transparent glass, with the above-mentioned minerals in it.

We are thus led to a layer perhaps an inch or two thick,<sup>2</sup> coarsely spongy, black, of pitchstone lustre, which

<sup>1</sup> I find a prettier example of this structure on one side of a piece of scoria picked up last month near the base of the active cone of Vesuvius. It was partly covered by the brown dust ejected since the tapping of the lava on the side of the Atrio del Cavallo last summer. I do not know, therefore, when it was erupted. I find on this, as on scoria that I saw erupted in October 1889, a tendency to form Pele's hair (on a very small scale).  
<sup>2</sup> Unfortunately, the only whole bomb that I saw went to pieces on the way to England. The point worth noticing is the difference in structure of different parts; and I give these rough measurements, taken from pieces in my possession, merely to show the kind of dimensions with which we are dealing.

bounds the internal cavities of the bomb. Sections show that this inner material is largely crystalline. Perhaps one-third of its substance is composed of well-marked crystals of triclinic felspar, olivine, and augite, the rest being a black ground material, opaque in sections of ordinary thickness, except where relieved by micro-crystals of felspar.

*Foerstner's Description of Specimens from Graham's Isle (Ferdinandea).*

With the above it is interesting to compare Foerstner's account of the specimens from Graham's Isle which he examined (*Min. and Petr. Mitth.*, v., new series, 1883, pp. 388-96). I suppose specimens are scarce. He obtained three. That from Strasbourg consisted of light-gray lapilli, apparently altered by acid vapours. It differed much macroscopically from the other two. These lapilli contained magnetite and plagioclase.

The other two were as follows (I give an abstract of Foerstner's description):—

(1) Specimen in Museum at Naples was pumiceous and almost foamy, and had a brown ground mass with glassy lustre, in which crystals of plagioclase, olivine, and magnetite.

(2) Specimen from Palermo (collected by G. Gemmelaro) was black and vesicular, but in sections was very similar to (1). It appeared to be largely crystalline. Plagioclase most conspicuous, but also augite, olivine, and magnetite.

I have not seen the specimens, but the descriptions accord well with those given above for the outer and inner material of the recent bombs. As will be seen below, they also agree well enough chemically.

*Description of certain Basic Scorix from the Island of Pantelleria.*

I did not obtain specimens of the plagioclase-basalts from the Cuddie Monti and S. Marco, analyzed by Foerstner (see below), but I have basic scorix from different localities in the north-west part of the island. Specimens from Cuddie Bruciate, while differing in structure, agree mineralogically with the recent ejecta, having crystals of triclinic felspar, olivine, and augite, set in a glassy or opaque black ground, as the case may be.

Further, some very black and rough specimens, from a small patch of basic scorix north-east of the Bagno del Aqua, not only agree mineralogically, but are in texture not unlike the intermediate portion of the bomb described above.

*A Comparison, as to Chemical Constitution, of the Products of the Recent Eruption with those of Graham's Island, and certain Lavas of Pantelleria, Etna, and Vesuvius.*

In the following table the iron oxides are taken together. In the case of the Etna lava of 1865, the analyses by Fuchs and Silvestri disagree as to the proportions of FeO and Fe<sub>2</sub>O<sub>3</sub>.

The results in the first four columns are from a table in Foerstner's paper (*loc. cit.*). For the fifth column I have to thank Mr. Geo. H. Perry, who has made an analysis of part of the large mass above mentioned, and also Prof. Thorpe, F.R.S., who kindly permitted the work to be done in the laboratory of the Royal College of Science. Mr. Perry's analysis will be found in full below.

This table speaks for itself. There is in the recent bomb a little less silica and a little more alumina than in the specimens from Graham's Isle, Etna, and Pantelleria, while the percentages agree with those in the specimen from Vesuvius.

NO. 1159, VOL. 45]

	Plagioclase-basalt, S. Marco, Pantelleria (Foerstner).	Plagioclase-basalt, Cuddie Monti, Pantelleria (Foerstner).	Plagioclase-basalt, Etna, 1865 (Dr. Silvestri).	Plagioclase-basalt, Graham's Isle, 1831 (Foerstner).	Bomb from sub- marine eruption N.W. of Pantelleria, October 1891 (Geo. H. Perry).	Lava-basalt, Vesuvius, 1867-68 (Fuchs).
SiO <sub>2</sub>	49.87	49.35	49.95	49.24	46.40	46.94
Al <sub>2</sub> O <sub>3</sub>	14.80	15.71	18.75	19.06	21.84	21.35
Iron oxides	15.13	14.40	11.30	12.10	11.57	12.23
MnO	—	—	0.49	—	trace	trace
CaO	9.36	9.80	11.10	8.75	10.33	9.69
MgO	6.77	5.71	4.05	5.00	5.37	3.78
K <sub>2</sub> O	0.68	1.31	0.70	1.19	1.69	5.57
Na <sub>2</sub> O	2.81	2.96	3.71	3.89	3.27	1.62
Water	0.45	0.49	0.70	0.63	—	—
	99.87	99.73	100.75	99.86	100.47	101.18

We may note that Foerstner<sup>1</sup> describes a decrease in the amount of silica in the rocks erupted on Pantelleria itself during the later part of its history. Thus, the oldest rocks of the island are described by him as phonolites, liparites, and andesites, probably of Tertiary age, containing from 60-73 per cent. of SiO<sub>2</sub>. Then, coming to the group of rocks which, as containing the mineral "cossyrite" (rather, *enigmatite*) and much soda and iron, he distinguishes by the name of "Pantellerites" (which rocks form the greater part of the surface of the island), he finds that the older ones contain about 70 per cent. of silica, and the younger only 67 per cent., thus heralding the outburst of basic rocks (lavas and scoria) containing some 49-50 per cent. of silica (see table above), which form the most recent rocks of the island, and are confined to the north-west part of it.

That we should find a still further decrease of SiO<sub>2</sub> to 46.40 per cent. is, so far, interesting. I have not come across an analysis of any very recent lava of Etna to know whether the lava of that district shows any tendency in the same direction.

In conclusion, I must express my thanks to Prof. Judd, to whom I am indebted for reference to the authors quoted, and for loan of papers.

December 26, 1891.

GERARD W. BUTLER.

ANALYSIS OF VOLCANIC BOMB, PANTELLERIA, OCTOBER 1891.

Percentage Composition of Washed Powder, dried at 120° C.

	1.	2.	Mean.
SiO <sub>2</sub>	46.39	46.42	46.40
FeO	2.20	1.88	2.04
Fe <sub>2</sub> O <sub>3</sub>	9.53	9.53	9.53
Al <sub>2</sub> O <sub>3</sub>	21.77	21.91	21.84
MnO	mere trace	—	mere trace
CaO	10.31	10.36	10.33
MgO	5.35	5.39	5.37
K <sub>2</sub> O	1.65	1.73	1.69
Na <sub>2</sub> O	3.42	3.13	3.27
Loss on ignition	—	—	—
	100.62	100.35	100.47

As the powder was magnetic, Fe<sub>2</sub>O<sub>3</sub> was probably combined with FeO to form Fe<sub>3</sub>O<sub>4</sub>. This would give—  
FeO 7.55  
Fe<sub>3</sub>O<sub>4</sub> 4.18

December 22, 1891.

Geo. H. PERRY.

<sup>1</sup> "Nota preliminare sulla Geologia dell' Isola di Pantelleria" (with geological map), *Boll. Com. Geol. d'Ital.*, 1881.

THE SPECTRUM OF IRON AND THE PERIODIC LAW.

IN the course of a prolonged series of spectroscopic observations on iron containing  $\frac{1}{10}$  carbon, '08 sulphur, '070 phosphorus, and about  $\frac{1}{10}$  per cent. of manganese, and based on the previous investigations of Mr. Lockyer on the iron spectrum at varying temperatures, I noted some results summarized as follows:—

(1) Iron heated *in vacuo* evolves a vapour showing the H spectrum; in addition, other lines are sometimes visible.

(2) I have found that iron kept in a vacuum slowly evolves H at a temperature not exceeding  $70^{\circ}$ – $80^{\circ}$ ; this continued for six months. Further, on applying heat, I have observed a condensed sublimate at the sealed cold end of the tube.

Heated iron known to contain small quantities of some of the more fusible metals evolves these bodies, and *vice versa* absorbs them. Exhausted heated iron also absorbs H in the same way, and most rapidly at an intense heat approximating to fusion.

(3) On iron being heated in the blow-pipe flame through which the spark was passing, lines were detected in the flame apart from the iron.

(4) On heating iron electrodes, "varying the tension of the spark,<sup>1</sup> also the flame temperature," according to methods elsewhere given, I found it possible to obtain iron spectra, varying roughly in accordance with the heat of the flame and spark tension. Three nearly distinct spectra have been observed:—(1) Lowest heat, a nearly pure manganese spectrum. (2) Higher heat, manganese lines; and other long lines appear, also the beginnings of a short-line spectrum. (3) Highest heat, a complete iron spectrum.

As regards the first spectrum, manganese has been identified by the ordinary method of chemical analysis. The second group of long lines the chemist would say were due to the presence of some body not identical with either iron or manganese, but this problematic body has not been identified or isolated; the proof is wanting, although it is a product, or function, of temperature, just as is the first or manganese spectrum. This spectrum may be due to dissociation of iron, and not to the vaporization of a foreign constituent. It is probable that iron can be roughly split up into two bodies, one of which is more volatile than the other, and that the relative quantity of each present may not always be the same. At any rate, it appears that by the simple heating of crude iron its composition may be sensibly modified, and that, even at a temperature as low as  $70^{\circ}$ – $80^{\circ}$ , slow dissociation is going on, manifested by the evolution of hydrogen; and this continues, the rate of dissociation apparently broadly corresponding to the heat applied. It follows that in actual practice the chemical composition of iron may thus be altered, such changes being probably so minute as to escape recognition.

These researches were made with the sole object of utilizing the spectroscope as an aid to the ordinary chemical analysis of iron, my previous experience having taught me that an extension of the usual methods was imperatively required. It was thought that by the spectroscopic method some body or bodies as yet unrecognized might be found; in other words, I searched for so-called impurities with but scant success.

Finally, I was forced to admit that I had exhausted the purely analytical part of the inquiry, and must seek for the solution of the many discrepancies observed in the behaviour of iron and steel, and not comparable with its chemical composition as determined by ordinary analysis. Nothing was left for further study, with the exception of the metal itself. It may be remarked, however, that

<sup>1</sup> Suggested by Mr. Lockyer.

absolutely pure metal could not be obtained; manganese, for instance, seems always present, even after repeated purifications.

This led to a study of the periodic law as enunciated by Mr. Crookes in his address on the genesis of the elements. He advances the rational hypothesis that atoms are formed from the original protyle or fire mist; next, by a series of atomic condensations, due to successive coolings, the elements are formed. Mr. Lockyer, by somewhat different methods of research, appears to have come to the same conclusion—viz. that temperature governs all; and tells us, "as the result of a long series of spectroscopic observations," that an element is a very complex thing, broken up—at higher temperatures—into simpler things.

Mr. Crookes, by a careful study of the periodic law, supplemented by spectroscopic work, shows how elements may be built up. Mr. Lockyer, pursuing the opposite method, viz. by a study of the breaking up of the so-called elements, and registering the results by means of the spectroscope, appears to have *experimentally* proved the same thing.

It is quite obvious that an absolutely pure element can only exist at a given temperature; any deviation from this—the critical temperature—must favour partial dissociation, and in this way it undergoes changes which may veil its true atomic weight. As Mr. Crookes puts it, "of a given mass of atoms, only a few may have the true atomic weight, the others slightly varying from it." Granting a variation of atomic weight in the element for the same reason, there may be a shifting of its spectral lines. I submit also that the discrepancies in the position of certain spectral lines may be due to divergence from the critical temperature, and not observational errors.<sup>1</sup>

There appears, therefore, to be no necessity for the use of such phrases as chemical affinity, cohesive force, &c.: heat energy and the universal law of gravitation seem the only factors controlling the genesis of the elements—can we also say the genesis of known chemical compounds?

We cannot well say how far the physical properties of such a metal as iron are modified by temperature variations; yet we have seen that something like dissociation is going on at  $70^{\circ}$ – $80^{\circ}$ , and that at a moderate heat this is accentuated; whilst at high temperatures the spectrum of iron affords ample proof that such is the case. Experiments have been made showing that even at the bare fusion-point of iron matter is volatilized; and at the abnormally high temperature of the Bessemer blow—"melting up lumps of cold steel plunged in, and weighing 2 or more cwt., like wax"—it is admitted that iron as such is vaporized. It seems therefore, on the whole, that even a stable body like iron, when heated, gives results according with the periodic law; and as regards other bodies, from ice upwards, we do not need to be informed that evaporation (dissociation) is constantly going on.

It may not, however, be so well known that "on heating some of the more fusible metals in a vacuum," it is possible to obtain almost invisible vapours, some of which iron occludes or absorbs just as it does the gases hydrogen and possibly carbon monoxide.

Referring to the No. 2 spectrum indicating the probable existence of an intermediate body betwixt iron and manganese, not yet isolated, but which, nevertheless, is a product or function of the temperature, just as manganese is; the supposition that this body is a constituent of iron acquires force from the fact that recently it has been shown that iron may be capable of assuming two forms—the one termed  $\alpha$ , or soft iron; the other  $\beta$ , or hard iron.

<sup>1</sup> Or, possibly, at a given temperature a vapour may be evolved from one body so nearly approximating in composition to that of another, the latter not necessarily at the same temperature, as to be almost undistinguishable from the other by the ordinary method of micrometric measurement. The same difficulty in another form occurs in ordinary chemical work; bodies are so closely allied in some instances as to render their separation and identification very difficult.

Consequently, the physical properties of the metal are modified in accordance with the relative proportions of each present.

It is thought that pure iron may contain both  $\alpha$  and  $\beta$  iron; but it is certain that when alloyed with other bodies—more especially carbon—these allotropic changes of iron become very marked. In this connection the author noted long ago that the carbon-iron alloys were more liable to change, and more sensitive to variations of temperature, than iron alloyed with other bodies; and, as the results of experience given, he goes so far as to advocate the substitution of other than carbon-iron alloy, in the following words:—

“For the production of steel in large masses suitable for ship and boiler plates, rails, &c., the traditional rules of the old school of steel-casters cannot well be applied.

“What is desired is a strong ductile material, capable of resisting sudden shock or impact, and sudden or extreme changes in temperature—a material as insensible as may be to all influence except that due to fair wear. This material—*i.e.* low carbon, Bessemer, or Siemens steel—has almost superseded wrought-iron, and yet is not always to be relied upon. Under certain ill-understood conditions this metal sometimes behaves in a manner which has not been satisfactorily explained.

“Must we infer that carbon may be the culprit, and that the carbon-iron alloy is more sensitive to external influences, and more liable to molecular changes, than other iron alloys free from carbon? <sup>1</sup>

“It is quite possible that further study and experiment may result in the production of an iron alloy, capable alike of being forged or cast in amorphous masses free from any tendency to hardness or temper.”

Osmond's researches have deservedly attracted great attention, and, in conjunction with the work of Prof. Ball and Prof. Roberts-Austen, have on the whole been approved and accepted by men of science.

With the aid of the Le Chatelier's pyrometer, the critical points of temperature, *i.e.* the points at which molecular changes take place, have been determined. The whole series of these masterly researches cannot here be given in detail; but after careful consideration the writer thinks they go far to prove that the undoubted molecular changes which take place when iron is heated simply represent marked periods of dissociation. That, broadly speaking, the results are in accord with the periodic law; with the spectroscopic work of Mr. Lockyer, and the researches of Mr. Crookes, together with the author's research on the behaviour of iron at varying temperatures; to say nothing of the work of other chemists all pointing in the same direction. As before said, the physical properties of iron are a function of temperature; indeed, one is fain to say that the absolute elementary body can only exist as such at a given temperature; at any other, it cannot, strictly speaking, be that body.

Appreciable dissociation can, however, only be noted at comparatively wide intervals of temperature; minor changes must, of course, be beyond recognition to our senses. It is possible that the first beginning, so to speak, of dissociation may be detected with the spectroscope; but unless carefully worked, the first spectroscopic indications of dissociation are not altogether trustworthy. The temperature of the spark and also the arc is subject to irregularities not easily controlled; and unless worked by the experienced spectroscopist, the results are apt to be unsatisfactory.

It is remarkable that many eminent chemists reject the spectroscope as a means of research, and prefer other methods. Others, again, consider that these methods of

procedure fail to differentiate minute differences, which yet substantially exist. The method of spectrum analysis, however, seems capable of registering reactions beyond the scope of ordinary analysis. In fact, the instrument may be said to afford the same aid to the analyst in enabling him to note infinitesimal chemical changes or reactions, as the microscope affords for the discrimination and classification of microscopic objects.

On the whole, the results of a long series of patient investigations show that pure iron is probably a very complex body (as regards the commercial metal the microscopic researches of Sorby go to prove that it clearly is not, as usually assumed, a homogeneous body, but rather a heterogeneous one), extremely sensitive to external influences modified by the presence of minute proportions of other bodies; these latter, according to Prof. Roberts-Austen, governing its physical properties in accordance with their atomic volume as compared with that of iron, and in accord with the periodic law. It is evident that it is not enough to give merely the simple percentage of carbon, sulphur, &c., in iron; the relative mass (as compared with iron) of the foreign ingredient must also be noted, and thus only can the *absolute* percentage composition be determined. Practical results appear to confirm those attained in theory.

The writer, when all these researches were not even thought of, in some notes on the working of steel, gathered from his own practice and confirmed by that of others, considered that the heat at which the steel was manipulated played a very important part, for the following reasons:—

Many discrepancies have been noted in the behaviour of steel—the results of the tests applied not at all corresponding to what might have been expected from its chemical composition. For instance, steel containing traces of silicon, .17 per cent. carbon, .06 of sulphur, .07 phosphorus, .40 per cent. manganese, stood a tensile strain of 27 to 30 tons per square inch; other samples of the same composition showed an increase of 31 to 35 per square inch, and under these latter conditions the carbon had to be reduced .12 per cent. to stand the normal test of 27 to 30 tensile strength.

The cause of this sudden change was not satisfactorily explained. I think a plausible explanation of these differences, which are of constant occurrence, may be traced to differences in temperature, and, strictly speaking, a steel of given chemical composition must be worked at a corresponding temperature to insure good results. Some clue to the temperature required may, however, be obtained. The fusion point of steel varies with the amount of other matter alloyed with the pure iron. All concerned in the manipulation of steel are well aware that hot or cold rolling makes a great difference in quality, and that the critical welding-point of the metal is confined to a narrow limit of heat; it is often a matter of great practical difficulty to decide upon the most suitable temperature necessary for good work. It is well known that steel may be seriously damaged either by under or over heating. In the first instance the steel may be too hard to bear rolling, or even if passed through it may not be sufficiently plastic to yield readily to pressure. We may in this case assume that minute cracks or flaws occur which cause a corresponding deterioration in strength. On the other hand, it is well known that if steel be over-heated it falls to pieces on further manipulation. The reason is apparent—it is approaching to a semi-fluid condition, and therefore cannot be rolled out. It may be, therefore, that for the successful working of steel it is not enough to rely simply on chemical analysis.

The foregoing seems to indicate that steel must be worked at a certain fixed, but as yet unknown, temperature below its fusion-point; at which heat the flow of

<sup>1</sup> Practically, we know that it is so; only pure carbon-iron alloys can be tempered and hardened with facility, the presence of other bodies tending to neutralize this effect; or, more plainly, the steel-smith terms it bad steel, which cannot be tempered or hardened properly.



heated metal undergoing compression and elongation is such as to insure good practical results.

It also follows that if the heat between these points can be ascertained, it may *only* be necessary to ascertain the fusion-point of any given steel, from which the working temperature can be determined, for the welding heat will obviously be a constant of temperature below the fusion-point of the steel sample, and it is probable that the discrepancies so often observable are simply due to deviations from the critical temperature required for welding and rolling purposes.

The welding or rolling heat should correspond to the fusion-point of steel, which is governed mainly by the amount of carbon it may contain, and possibly other elements may play a part in affecting the final result.

Finally, as the results of purely practical experience, the writer has been led to think that the term impurity, as applied to the mixed foreign elements present in iron, "is simply a conventional one, applicable only under certain rigid conditions of temperature combined with manipulation"; and these must be present in fixed quantities, bearing uniformly the same ratio to each other. It follows that under other conditions of temperature and manipulation a product possessing the same physical properties might be produced from a material sensibly differing in composition from that quoted above.

It is well known that those solely engaged in the manufacture of iron and steel have, "independent of the teachings of science," long ago come to the conclusion that iron undergoes unaccountable changes. It is asserted that ordinary chemical analyses afford no explanation of the observed phenomena; further research is insisted upon. To use their own words, they ask "What is iron? In our practice something often happens to iron of which your analyses afford no explanation." It is to be hoped that recent research has partly solved the problem; and that, by a further study of the metal itself, some clue may be found indicating more clearly than at present that iron is either a true chemical compound, or, if not, subject to allotropic modifications.

Practically, it does not seem to matter which, as to quote the words of Dr. Gore, "every substance becomes a more or less different substance at every different temperature" (*Phil. Mag.*, May 1890).

JOHN PARRY.

#### THE GROWTH OF THE PILCHARD OR SARDINE.

IT was long since proved that the pilchard of the southwest coasts of England and the south coast of Ireland is the same species of fish as the sardine of the Atlantic coasts of France and Portugal, and of the Mediterranean. But there are apparent differences in the sizes and habits of these fish in different regions, of which the explanation has only recently been sought. The life-history of the species has been studied during the past few years with great care by several naturalists at various points of the coasts along which its habitat extends; and as a result of these researches, the extent to which its local peculiarities are real or only apparent is gradually being ascertained. Thus Marion at Marseilles has established the facts that the Mediterranean sardine in that neighbourhood spawns chiefly in February and March, but that the spawning period extends from December to May, that the adult fish does not exceed 18 cm. in length, and that the smallest sexually mature individuals are 15 cm. long. The majority of the pilchards caught by drift-nets on the south coasts of Devon and Cornwall are from 20 to 25 cm. in length, while those which I have seen in the ripe condition were 23 to 25 cm. Thus it is clear that the Mediterranean sardine, at any rate in the Gulf of Lions, is in its adult state a much smaller fish than the Cornish

pilchard, although no structural differences have yet been described which would separate the two as local races or varieties.

The well-known French sardine, such as we see it preserved in oil in tins, is also a small fish. The sardine fishery and the sardine-preserving industry in France are carried on along the south coast of Brittany from La Rochelle to Brest. The great majority of the sardines caught there are fish from 13 to 16 cm. in length. Considering the short distance between Cornwall and Brittany, it might be suspected that these fish are not full grown; and Prof. Pouchet, Director of the Zoological Laboratory at Concarneau, tells us in his Reports that these sardines are young fish which have not yet reached sexual maturity. In fact, full-grown sardines of the same size as typical Cornish pilchards are also caught on the Breton coast, and are locally distinguished as "*sardines de dérive*," the small fish used for tinning being called "*sardines de rogue*." The adult sardines are captured principally in winter, the *sardines de rogue* in summer. The question therefore arises whether small pilchards of the same size as the *sardines de rogue* of the French coast occur on the coasts of Cornwall, and if not, why not. During the four years I have been at the Plymouth Laboratory I have never heard of any such fish being caught by the fishermen. Not long ago I asked Mr. Dunn, who has been engaged in the Cornish pilchard trade the greater part of his life, if he had ever seen any pilchards of the same size as French sardines, and he said he never had. He is connected with the factory at Mevagissey, where adult pilchards are prepared in oil in tins in the same way as French sardines, and he told me that some years ago the owners of the factory took steps to ascertain whether pilchards of small size could be captured near Mevagissey. A seine of the kind used by the French fishermen was procured from France, and several trials were made with it; but instead of half-grown pilchards of the required size, it captured only very young specimens 2 or 3 inches long. The recent capture, therefore, in nets belonging to the Marine Biological Association, of young pilchards similar in size to the French *sardines de rogue* is a matter of some interest and importance. The discovery also adds considerably to our knowledge of the growth and history of the pilchard.

Some months ago the Director of the Plymouth Laboratory was instructed to procure a fleet of small-meshed drift-nets for the purpose of catching anchovies, in order to ascertain at what seasons and positions and in what abundance these fish appeared off Plymouth. These nets are five in number, each being 60 fathoms in length; the mesh is about  $\frac{1}{2}$  inch square, or 70 meshes to the yard. They were shot a few miles outside Plymouth Breakwater on November 3, 4, 5, and 6, and on each occasion the chief part of the catch consisted of pilchards measuring 13 to 16.5 cm. in length. The rest of the catch consisted of a few full-grown pilchards, a few young mackerel, a few sprats, and sometimes a few anchovies. On each occasion there was a considerable difference in size between the smallest of the large pilchards and the largest of the small. The spawning period of the pilchard off Plymouth extends from the beginning of June to the beginning of November—five months—and may possibly be prolonged a little beyond these limits. Now all the available evidence tends to show that even the smallest of the young pilchards above mentioned, 13 cm. in length, could not have reached that size if hatched the same year, even if they were derived from eggs shed in May. For in the latter case they would be only a little more than five months old. Meyer found that herrings at five months were only 6 to 7 cm. long, and Marion states that the sardine at Marseilles is 7 cm. long at the same age. It might be argued that the Atlantic pilchard grows faster than the Mediterranean sardine, but it can scarcely grow so much faster as to reach 13 cm. in five months. It is pretty

certain, therefore, that these young sardines were derived from the previous year's spawning, and were between twelve and seventeen months old, probably thirteen to fifteen months. This being the case, the young pilchards hatched the same year ought to have been discoverable. Day states, doubtless on Mr. Dunn's authority, that young pilchards are first seen in September, 3 or 4 inches long—that is, 7.5 to 10 cm. Mr. Dunn himself tells me that the young pilchards about this size regularly occur off this coast in autumn, and that he has seen them taken in seines and in the stomachs of whiting. I found young pilchards myself in the stomachs of the young mackerel taken in the anchovy nets at the dates above mentioned, and in full-grown mackerel examined at the same time. These young pilchards measured 6 to 9 cm., and were doubtless derived from spawn shed the previous summer. It is, of course, possible that the pilchards measuring 13 to 16.5 cm. in length at the beginning of November were derived from spawn shed rather late in the spawning season of the previous year, and that their age was nearer twelve than seventeen months. But the above facts indicate clearly that the pilchard does not reach adult size in one year, and is not capable of spawning until it is two years old, while the larger spawners are probably three years old.

If we compare the data and inferences just given with the facts concerning the sardine of the French coast recorded by Pouchet, we find that the data agree and the inferences are confirmed. Pouchet, it is true, denies that the eggs of the sardine are pelagic, and has not defined the spawning period. But he tells us that he has only seen eggs approaching maturity in fish taken in April and May, when the fishing for *sardines de dérive* ceases, and that for *sardines de roque* commences. There can therefore be no doubt that near Concarneau the sardine spawns in the months following May. Pouchet's records of the fish captured are somewhat difficult to interpret. He publishes in his Reports the records kept by the manufacturers, in which the size of the fish is registered according to the number required to fill a tin of a certain size. Two processes of calculation have to be carried out in order to get approximately the length of these fish. Having made these calculations, we find that at Concarneau in 1888, in June, the *sardines de roque* were 12.5 to 14 cm. long; in July, 13 to 14.3 cm.; in August and September about the same; in October, for the most part 15 or 16 cm., though some were still taken of 13 to 14 cm. In some of his reports Pouchet gives the dimensions according to actual measurement of two or three sardines taken nearly every day throughout the season, but nowhere does he give the range of sizes of the total number of fish taken on one day. Thus in the year 1888 he obtained sardines of 10 to 11.5 cm. in March, 11 to 14 cm. in April, 15 cm. in May, 13 to 15 cm. in June, 13 to 16 cm. in July, 13 to 14 cm. in September, 14 to 18 cm. in October. On the whole, the *sardine de roque* gets larger towards the end of the season, though it is obvious that the shoals in a given place replace one another, so that fish taken in September at Concarneau may be of the same age and size as others taken in June. This phenomenon is a necessary consequence of the extended spawning period of the species. But I think there can be no doubt that the *sardines de roque* caught in such numbers along the coast of Finisterre in summer are yearling fish, which in the following summer reach maturity at a length of 20 to 22 cm. There is one consideration which may give rise to a doubt as to the general validity of this conclusion. According to Pouchet, sardines 15.7 cm. long are taken at the end of May: would not these reach a length of 19 or 20 cm., and be capable of spawning, by the end of October, when the spawning period for the year is not yet terminated? This question cannot be definitely answered in the negative at present. I will merely point out that the incre-

ment of length corresponding to the same increment of weight becomes smaller as the fish grows larger. Thus at 13 cm. a sardine weighs about 15 grammes; at 16 cm. about 30 gms., an increase of 15 gms.; at 19 cm. it weighs about 60 gms., an increase of 30 gms.

If, as the above considerations indicate, the sardine of the Cornish and French coasts reaches a length of 13 to 16 cm. at one year of age, it is surprising that the Mediterranean sardine should reach the same length at the same age, since its maximum length is so much less than that of the more northern fish. But Marion finds that the sardine at Marseilles grows at the rate of 1 cm. per month, starting from a length of 3 cm. at one month old. Thus, according to his table of growth, the sardines hatched in December are 14 cm. long in the following December. I cannot help thinking that Marion has over-estimated the rate of growth, but it may prove that the fish reaches maturity more quickly in the Mediterranean, although it does not grow so large. Marion has conclusively shown that the spawning period at Marseilles extends from December to May, instead of from May to October.

J. T. CUNNINGHAM.

### SCIENCE IN JAPAN.<sup>1</sup>

THE growth of modern science in Japan is one of the most interesting phenomena connected with the history of civilization. The Japanese, and the Magyars of Hungary, are the only peoples of other than Aryan stock who have founded Universities and taken part in the development of the historical and physical sciences. The University of Buda-Pesth dates from the fifteenth century, and at the present moment its large staff of eminent Professors contains but few names which are not distinctively those of Magyar nationality. The University of Tokyo was founded in the year 1868 by the union of the Tokyo Daigaku and the Kobu Daigakko. It has more than seven hundred students, and comprises a College of Law, with eleven Professors, of whom one only is a European; a College of Medicine, with sixteen Professors, all native Japanese; a College of Engineering, with eighteen Professors, three of whom bear English names; a College of Literature, with ten Professors, of whom two are Englishmen and two Germans; a College of Science, with fifteen Professors, amongst whom one—a chemist—is English, the rest being Japanese.

The present volume bears testimony to the high qualifications and serious work which distinguish the Japanese Professors and their assistants in the College of Science of Tokyo. It contains seven memoirs on biological subjects—a branch of study for which the Japanese have proved themselves during the last fifteen years to have a special and indeed a remarkable aptitude. The names of Mitsukuri, Ishikawa, Iijima, and Watase, not to mention others, are known and esteemed in every laboratory in Europe and America where the study of embryology and comparative anatomy is cultivated.

The list of papers in the present volume is as follows:—(1) The fetal membranes of the Chelonia, by K. Mitsukuri, with ten plates; (2) The development of Araneina, by K. Kishinouye, with six plates; (3) Observations on fresh-water Polyzoa, by A. Oka, with four plates; (4) On *Diplozoon nipponicum*, n.sp., by Seitaro Goto, with three plates; (5) A new species of Hymenomycetous Fungus injurious to the mulberry-tree, by Nobujiro Tanaka, with four plates; (6) Notes on the irritability of the stigma, by M. Mujoshi, with two plates; (7) Notes on the development of the suprarenal bodies in the mouse, by Masamaro Inaba, with two plates.

Some of the authors of these admirable papers bear the title "Rigakushi," whilst Prof. Mitsukuri alone is styled

<sup>1</sup> "The Journal of the College of Science, Imperial University, Japan," vol. iv., Part 1. (Tokyo, Japan, 1891.)

“Rigakuhakushi.” All the memoirs above named are valuable contributions to science, and are profusely illustrated by lithographic plates, which compare favourably with the best European work. Prof. Mitsukuri’s memoir on Chelonian development is the most important; it forms a continuation of a memoir on the germinal layers of the Chelonian, published by him in conjunction with Mr. Ishikawa in 1887 in the *Quarterly Journal of Microscopical Science*.

English-speaking naturalists may congratulate themselves on the fact that the English language is chosen by our Japanese *confères* as their medium of publication: English, indeed, appears to be the official language of the Imperial University of Tokyo throughout. Whilst the Russian Government encourages its scientific *protégés* to withdraw themselves more and more from European intercourse by publishing their investigations in the Russian language, the Far East steps gladly into the place among civilized nations vacated by the long-suffering subjects of the Czar. E. RAY LANKESTER.

EVIDENCE OF A WING IN DINORNIS.

IN 1889, Mr. A. Hamilton, of the Otago University, submitted to me some of the Moa bones he had exhumed from a swamp near Te Aute, in the North Island of this colony. Among them there were several very diminutive scapulo-coracoids and sterna, which I hope soon to figure and describe. Among the former was one which presented a small but distinct hollow in the situation where the glenoid cavity occurs in the winged Ratitæ. I made a sketch at the time, and exhibited the bone at one of the meetings of the Philosophical Institute of Canterbury. Though satisfied in my own mind that this hollow did represent a humerus articulation, I have been unable to find confirmation of its existence in any other scapulo-coracoid among the Moa collections I have examined. Among the bones, however, which I lately dug up from a peaty hollow near Oamaru, in the South Island, I have found a large scapulo-coracoid presenting a deep, well-marked depression, with a beautifully smooth and polished concavity, which leaves no room for doubt that it has



Scapulo-coracoid of *Dinornis* sp., showing the glenoid cavity.

been a functional glenoid cavity for a humerus possessing a head not less substantial at least than that in the Cassowaries. The accompanying drawing (half the natural size), made by camera lucida, will convey better than a description the form and position of the depression. Proximally to the cavity, and separated from it by a smooth ridge, there is a shallow impression (not seen in the figure), as if it were an antitrochanter for some tuberosity on the humerus. The coracoid termination of the bone fits perfectly into a deep and rounded depression in a sternum obtained at the same time and place as the scapulo-coracoid, belonging to *Dinornis maximus* of Owen. Prof. T. J. Parker has proved that the *Apterygida* are undoubtedly descended from birds that could fly: the finding of so unmistakable a glenoid cavity in the present bone confirms the generalization for the *Dinornithideæ*. HENRY O. FORBES.

Canterbury Museum, Christchurch, N.Z.,  
November 4, 1891.

NOTES.

THE medals and funds to be given at the anniversary meeting of the Geological Society, on February 19, have been awarded as follows:—The Wollaston Medal to Baron Ferdinand von Richtofen; the Murchison Medal to Prof. A. H. Green, F.R.S.; and the Lyell Medal to Mr. George H. Morton; the balance of the proceeds of the Wollaston Fund to Mr. O. A. Derby; that of the Murchison Fund to Mr. B. Thompson; that of the Lyell Fund to Mr. E. A. Walford and Mr. J. W. Gregory; and a portion of the Barlow-Jameson Fund to Prof. C. Mayer-Eymar.

PROF. WILLIAMSON, F.R.S., has been elected a corresponding member of the Imperial Academy of Sciences, St. Petersburg.

THE Belgian Academy is preparing to celebrate the fiftieth anniversary of M. Van Beneden’s membership. He is the Professor of Natural Sciences at the University of Louvain.

THE private or preliminary installation of the Duke of Devonshire as Chancellor of the University of Cambridge, in succession to his father, took place at Devonshire House on Tuesday. An admirable speech was delivered by the new Chancellor in reply to addresses by the Vice-Chancellor and the Public Orator Speaking of the University of Cambridge as it was it was in his undergraduate days, he said that the University did not at that time present in so attractive a form as she did now that instruction in the study of history, constitutional law, political economy and natural sciences, which perhaps, at the present day, formed the best preparation for one who intended to aspire to take part in the management of the affairs of his country. He believed that the estimation in which high education was held had been so greatly enhanced that the Universities had nothing to fear from attacks of cupidity, envy, hostility, or ill-will. The worst they had now to apprehend was excessive zeal on the part of those who, with the best intentions, but perhaps with insufficient knowledge and experience, sought to extend more widely and more generally their influence and their usefulness. The University of Cambridge had been steadily increasing its influence and responsibility. In an expanse so wide as that covered by science and learning, the time would never come when new fields would not be open for everyone. Most of what had been done was due to the devotion and ability of their own members—men whose names were more familiar to those present than they were to himself, so that it would be invidious for him to attempt to specify them. The progress of the Cambridge University in the future, as in the past, must be mainly its own work. The time might come when their ever-extending labours—labours undertaken in response to the growing wants of the community—might be received with even wider national recognition than they had hitherto been. So far as it might be in his power, in the office to which they had done him the honour to call him, to serve as one of the links which bound the University to the great body of the people whom she existed to serve and instruct, that service, imperfect as it might be, would be cheerfully given.

THE nineteenth annual dinner of the old students of the Royal School of Mines was held at the Holborn Restaurant on Tuesday. Mr. H. Bauerman occupied the chair, Sir G. Stokes and Sir Lyon Playfair being among the guests. Responding to the toast, “The Mining and Metallurgical Industries,” proposed by the Chairman, Prof. Roberis-Austen spoke of the value of metallurgical science. In illustration of its importance, he said that, if the thousands of tons of steel in the Forth Bridge had contained two-tenths less of carbon, the material would have been worthless, that thousands of tons of copper would be useless if it contained a trace of bismuth, and that the eighty millions sterling of gold coin which Sir C. Fremantle had been responsible for would have crumbled away if

it had contained one-tenth per cent. of lead. Sir Lyon Playfair, responding for the past professors, in the course of his speech remarked, "We are looking to the promise of the Government that increased accommodation will be given by the erection of new buildings behind the British Museum at South Kensington. A public man is of no use unless he can look ahead and see the wants of the future. I can take this credit to myself, that for many years I have seen the need of your expansion, and, having some influence in the destiny of the vacant land at South Kensington, I always resisted granting any land opposite the College of Science that might prevent the natural growth of the science institutions at South Kensington. But there was a greater man than myself, the Chancellor of the Exchequer, who very nearly succeeded in grabbing that land for an art gallery. I hope that project is at an end, and that the land long destined for the growth of science will only be applied to that purpose."

PROF. VICTOR HORSLEY, F.R.S., will, on Tuesday next (January 19), give the first of a course of twelve lectures, at the Royal Institution, on the brain. Prof. J. A. Fleming will on Saturday (January 23) give the first of a course of three lectures on the induction coil and alternate current transformer. The Friday evening meetings will begin on January 22, when the Right Hon. Lord Rayleigh, F.R.S., will give a discourse on the composition of water.

THE Council of the Royal Meteorological Society have arranged to hold at 25 Great George Street, S.W., from March 15 to 18 an exhibition of instruments, charts, maps, and photographs relating to climatology. The Exhibition Committee invite the co-operation of all who may be able and willing to help them, as they are anxious to obtain as large a collection as possible of such exhibits. They will be glad to show any new meteorological instruments or apparatus invented or first constructed since last March, as well as photographs and drawings possessing meteorological interest.

MEDICAL science in France has lost one of its most prominent representatives in Prof. Richet, who died on December 30, 1891. He was seventy-five years of age. M. Richet was a member of the Academy of Sciences, and in 1879 acted as President of the Academy of Medicine.

THE death of Dr. Ferdinand von Roemer, Professor of Geology and Palaeontology in the University of Breslau, is much regretted by all students of geological science. He was in his seventy-fourth year, and proposed to celebrate his jubilee as Professor on May 10, 1892.

WE regret to have to record the death, on the 5th inst., of pneumonia, after a very short illness, of Dr. Albert J. Bernays, Lecturer on Chemistry at St. Thomas's Hospital. He was the author of several works of great value to medical students: "Household Chemistry," "Lectures on Agricultural Chemistry," "First Lines in Chemistry," "Notes for Students in Chemistry," &c.

THE rich collection of dried mosses formed by the late Prof. S. O. Lindberg has been acquired by the Botanical Museum of the University of Helsingfors.

DR. H. JAGOR, the well-known ethnologist, is about to proceed to Saigon, and will visit Cambodia and Tonquin. Dr. Jagor recently spent some time in Java, renewing the impressions which he formed nearly thirty-five years ago on his first extensive scientific tour through the countries of the Far East. His book on the Philippines is still a work of great value.

THE question of removing the Madras Observatory to a station in the Pulneys or Neilgherries is occupying the attention of the Governments of India and Madras. The transfer is recommended in order to obtain an atmosphere with the mini-

mum of cloud. If this project is carried out, solar observations will be conducted there instead of at Dehra in the North-West Provinces. The Meteorological Department has arranged for a trial of observations in 1892, at Kodai Kanan, in the Pulneys, and Kotaigiri, in the Neilgherries.

It is stated that the Japanese Budget for the next fiscal year includes an appropriation for the construction of meteorological observatories in all the prefectures not yet provided with such establishments. Should the Parliament approve this item, the Empire will be completely covered with a network of observatories.

THE Pilot Chart of the North Atlantic Ocean, in its review of December 1891, notes that along the American coast the month began with cool pleasant weather, accompanying a strong anticyclone that hung persistently about Hatteras for several days, giving northerly winds and clear weather off the Atlantic coast and as far south as the Caribbean Sea, and warm southeasterly and southerly winds in the Gulf of Mexico. On the Atlantic, however, December opened with very stormy weather, prevailing throughout almost the entire region from Bermuda to Rockall and the Bay of Biscay. One hurricane was central about 700 miles north-east from Bermuda, and another storm—one of great extent and severity—central about lat. 58° N., long. 25° W. On December 6 and 7 fresh to strong southerly winds prevailed off the American Atlantic coast, whilst a northerly set in over the Gulf of Mexico, attending the approach from the westward of an anticyclone that caused northerly gales in the Gulf Stream region and as far south as the Caribbean Sea on the 8th and 9th, with persistent northerly winds and cold weather until the 14th. Various storms reached the Atlantic from the Gulf of St. Lawrence. No ice was reported south of the latitude of Cape Race. There was very little fog, none having been reported until toward the end of the month. On the 22nd a large fog bank extended from about Sable Island to Sandy Hook, accompanying an anticyclone. Reference is made by the Pilot Chart to "the extremely dense fog that overhung London from the 22nd to the 26th."

It is perhaps not generally known that the Annual Reports relating to H.M. colonial possessions frequently contain meteorological observations in addition to other useful information. We extract the following particulars from the Annual Report for the Leeward Islands for 1890. From the records of the temperature, pressure, and rainfall at the Government Laboratory, Antigua, the hottest month there, during that year, was September, with an average maximum temperature of 88°. The absolute maximum was 91°, in June, and the minimum 62°, in April. The average rainfall at 45 stations in the island was 33 inches, and was very much below the usual amount. There were several slight shocks of earthquake during the year, but no damage was done.

IN the *Repertorium für Meteorologie* (vol. xiv. No. 10), M. E. Berg discusses the frequency and geographical distribution of heavy daily rainfalls in European Russia, excepting Finland and the Caucasus. The observations refer to the years 1886-90, a rather short period; but in previous years there were not sufficient stations for such an investigation. The paper deals exclusively with falls of between 1·4 and 3 inches, distributed according to months, for the various Governments of the Empire. The results show that the frequency of heavy falls is subject to considerable fluctuation from year to year. The regions of greatest frequency occur on the south-east coast of the Crimea and the extreme south-west of the Empire; on the eastern side of the Dnieper, the region extending to Smolensk and further northwards is also subject to very heavy falls. The northern limit of daily falls of over 3 inches, so far as relates to Central Russia, is the Government of Moscow. The yearly range of frequency reaches a

maximum in summer, and, except in the south-eastern districts, the frequency in autumn is greater than in spring. In July and August the great falls extend over very large districts, and at other seasons are generally regulated by the course of the barometric depressions. The following is the average yearly frequency of the heavy falls for the whole Empire, arranged according to seasons: winter, 0·8; spring, 14·3; summer, 106·4; autumn, 20·8. The maximum amount which fell in any day was over 8 inches, in Bessarabia.

THE floating of the particles of cloud or fog, Herr von Frank, of Graz, seeks to explain (*Met. Zeit.*), by the presence of an envelope of aqueous vapour. As an approximate average value for the diameter of droplet with envelope he gives 0·7 mm. Supposing one cubic metre of cloud to hold 3 grammes of water, there would be an interval of 0·2 mm. between the envelopes. When clouds pass over the sun, the shadows of objects are perceptibly lengthened when the darkening occurs, and the author attributes this to refraction by the vapour envelopes. Again, it is difficult to see how water droplets in the form of cloud or fog could exist at such various temperatures, did not the vapour envelopes, as bad conductors of heat (compare Leidenfrost's drops), guard the droplets to some extent from evaporating and freezing. The minute particles must soon be dissipated by the sun's rays, if they were not in a kind of spheroidal state. This heating expands the envelopes, so that the cloud tends to rise; and various phenomena in Nature may be thus explained (*e.g.* the rise of mist in Alpine valleys). Once more, liquid droplets have been observed (by Assmann) floating in air of  $-10^{\circ}\text{C}$ . On meeting a solid body these froze to icelumps without crystalline structure. Here, according to Herr von Frank, the vapour-envelopes prevent freezing, till they are ruptured by the solid; the droplet thus loses the bad conductor of heat which protected it, and solidifies so quickly that no crystals can form. The author supposes that with much aqueous vapour in the air, larger drops form, the clouds floating lower; with less aqueous vapour, the drops are smaller and the clouds higher; the thickness of envelope, however, being the same for large and small drops under like conditions of temperature and pressure.

ON January 5 slight shocks of earthquake were felt at Verona, Peschiera on the Lago di Garda, Illasi, Parma, Modena, and Chiavari; and on January 6 slight shocks were felt at Rochester, New York. A telegram from Athens, dated January 11, states that several severe shocks of earthquake, accompanied by subterranean noises, had been felt in Thessaly, especially in the neighbourhood of Larissa.

ON January 14 a fresh stream of lava was issuing from the base of the great cone of Mount Vesuvius on the northern side.

MR. HERBERT JONES, to whom has been intrusted the charge of the animal and vegetable remains found at Silchester during the excavations last year, writes to the *Times* that all the bones which are sufficiently perfect will be carefully measured for comparison with those of modern animals and with bones found on other ancient sites. This examination is yet very far from complete, but Mr. Jones is inclined to think that the remains of the red deer are those of animals considerably larger than are common at the present day. The roe deer appears to have been of about the ordinary size. The bones of the ox, of which the only variety met with is apparently *Bos longifrons*, and those of the sheep are very small; also the horses' bones, two varieties of which are present in the collection. It is probable that the horses were of about the size of Exmoor or New Forest ponies, the cattle much like the Kerry or Britany breeds, and the sheep similar to those now found on the island of St. Kilda. These

results are quite tentative, but Mr. Jones points out that so far as they go they confirm the deductions made by Lieut.-General Pitt-Rivers, F.R.S., from the animal remains found by him at his excavations of a Romano-British village, near Rushmore, on the borders of Wilts and Dorset.

LAST week we referred to a "new herbarium pest" to which Dr. C. V. Riley calls attention in *Insect Life*. Writing on the subject in the *Gardener's Chronicle*, Mr. R. McLachlan points out that an insect of similar habit has been known in Europe for nearly a century. In 1798, Fabricius described a moth, now known as *Acidalia herbariata*, and says of it, "Habitat in herbariis folia plantarum exsiccatarum exedens, Mus. Dom. Bosc." This moth has occasionally been found in England, and has been recorded as infesting herbalists' shops; it has been found nearly all over Europe, and usually in herbaria. A complete account of its transformations by Dr. Heylaerts is given in the *Annales de la Société Entomologique de Belgique* (tom. xxi. pp. 1 to 8, 1878).

MESSRS. PRATT AND SON, Brighton, state in the current number of the *Zoologist* that they have recently set up a specimen of the spotted eagle which was shot at the Sudbourne Hall Estate, Wickham Market, Suffolk, and sent to them for preservation. It proved on dissection to be a male, and its stomach contained the remains of a water rat and a partridge. It was killed on November 4. Another bird had been seen in its company, and was no doubt the one caught at Colchester, as recorded by Mr. H. Laver in the *Zoologist*. The bird sent to Messrs. Pratt and Son was in perfect plumage, beautifully spotted, and evidently in its second year; it weighed  $3\frac{1}{2}$  pounds.

THE U.S. Commission of Fish and Fisheries has issued a full and very interesting Report on the fisheries of the Great Lakes. The review is based mainly on data obtained in 1885. While commercial fishing is the chief and practically the only subject considered, the importance of pleasure-fishing on the lakes has been incidentally referred to. Although there are no statistics to show the amount of fish caught by sportsmen and other pleasure-seekers, it is known that the quantity and value of the fish so taken are very considerable. Mr. J. W. Collins estimates, from his own observations, that no less than 10,000 dollars' worth of fish is taken every year from the break-water at Chicago by men, women, and children who go there in summer for a day's "outing."

PROF. PUTNAM has received 20,000 dollars from a Connecticut gentleman, whose name is withheld, to enable him to search in South America for objects of anthropological interest, to be exhibited at the Chicago Exposition. A part of the exhibit in Prof. Putnam's department will be a fine collection of cliff-dwellers' relics, gathered by the Rev. C. H. Green in Colorado, Utah, New Mexico, and Arizona.

MUCH interest has been excited in New York by the use of electricity in a representation of "Julius Cæsar" which is being given in that city by the Meiningen company. The thunder-storm in the third scene of the first act is said by *Electricity* to be the finest achievement of the kind ever seen in New York. The lightning effects are "exceptionally lurid and realistic."

THE Report of the President of the Johns Hopkins University for 1891 has been issued, and all who are interested in the higher education in the United States will be glad to learn from it that the attendance of students was larger than it had been in any previous year, while their quality was satisfactory. The number of graduates also showed a marked increase. The President notes that electrical engineering has received especial attention, "at a considerable though still inadequate outlay."

IN a paper entitled "The Navajo Belt-Weaver," published by the Smithsonian Institution, Dr. Shufeldt gives an excellent account of weaving as practised by the Navajos. While living in the north-western part of New Mexico, he was able to watch native weavers preparing their beautiful blankets, belts, and sashes; and on one occasion he was fortunate enough to have an opportunity of photographing an Indian woman while engaged in weaving a belt. The reproduction of the photograph is interesting, and is said by Dr. Shufeldt to show the entire scene well. Curves are never found in the figure patterns on the belts or blankets, but horizontal stripes, diagonals, and the lozenge are interwoven with a variety that appears to be almost endless in the matter of design. The leading colours used are red, brilliant orange yellow, a blue, and by combination a green, and, finally, black, white, and grey.

MR. W. T. ROBERTSON gives in the October number of the *Agricultural Gazette of New South Wales* a clear and interesting account of the cultivation and manufacture of tea. The object of the paper is to supply the farmers of New South Wales with information which they may be able to turn to practical advantage. Mr. Robertson does not think that the colony can ever manufacture sufficiently large quantities of tea to put it in a position to compete with China, India, and Ceylon. He sees no reason, however, why the industry should not be conducted on a modest scale. A farmer with children could utilize their labour in the plucking and the light work in manufacture, while the heavier he could undertake himself. If the owner had, say, an acre under cultivation, it would probably bring him in 300 pounds of made tea per annum—enough for his own consumption, with a surplus which he could dispose of at a good profit.

M. PAUL TOPINARD contributes to the new number of *L'Anthropologie* a most interesting paper on the transformation of the animal skull into a human skull. The process may be explained, he thinks, by the influence, direct and indirect, due to the enlargement of the brain. There is also a paper, by M. G. de Lapouge, on various prehistoric skulls from the collection of M. Puech, of Montpellier; and Dr. R. Collignon brings together some facts relating to the colour of the eyes and hair of the Japanese.

A WORK on the great earthquake of Japan, by Prof. John Milne and Prof. W. K. Burton, is now in the press at Tokyo. It will be illustrated by 25 large photo-plates. For the sake of comparison, there will be two plates showing on a small scale the effects of earthquakes in Italy and other countries. All the plates are to be on the finest quality of Japanese paper.

THE prospectus is issued of a *Forstlichnaturwissenschaftliche Zeitschrift*, an organ for laboratories of forest-botany, forest-zoology, forest-chemistry, agriculture, and meteorology. It is to appear monthly in Munich, under the editorship of Dr. Carl Freiherr von Tubeuf; the first number is announced for the current month.

MM. ROUY AND FOUCAUD expect to publish the first fascicle of their new *Flore de France* in the course of the coming year.

MR. ELIOT STOCK has published a fourth edition of Mr. H. W. S. Worsley-Benison's "Nature's Fairy-Land."

PART 39 of Cassell's "New Popular Educator" has been published. It includes, besides many illustrations in the text, a coloured plate representing the Great Hall, Karnac.

FURTHER details of his experiments upon the colour and spectrum of free gaseous fluorine are contributed by M. Moissan to the January number of the *Annales de Chimie et de Physique*. The apparatus employed was, of necessity, constructed of platinum, and M. Moissan prefaces his description of it with an account of a few later observations upon the action of fluorine on platinum. He finds that fluorine may be stored for days in his vessels of platinum without the slightest action occurring, pro-

vided the precautions which he has previously described are taken to remove the last traces of hydrofluoric acid vapour from the gas. Moreover, even at 100° fluorine was found incapable of effecting the least alteration in a spiral of platinum wire immersed in the heated gas. It is not until a temperature superior to 400° is attained that corrosion commences, and the platinum vessel requires heating to low redness before rapid action occurs.

IN order to ascertain whether fluorine, like other members of the family of halogens, was possessed of a distinctive colour, a tube of platinum, one metre long and two centimetres diameter, was procured. The two ends of this tube were closed by disks of faultlessly clear and colourless fluor-spar, a commodity of great rarity. Near the ends were inserted narrow side-tubes of platinum for the entrance and exit of the fluorine; the ends of these side-tubes were closed by small, tightly-fitting stoppers, also of platinum. The whole apparatus held about 200 cubic centimetres of gas. In performing the experiment, pure fluorine was allowed to stream through the apparatus until a crystal of silicon held at the end of the exit-tube burst into flame. The stoppers were then inserted, and the colour of the inclosed gas examined against a white background. For the sake of comparison a similar observation was made with a blackened glass tube, closed at the ends with plate-glass disks, and filled first with air and afterwards with chlorine. The colour of fluorine is then seen to be somewhat paler than that of chlorine, and decidedly more yellow—just what one would expect from the position of fluorine at the head of the halogen family group.

THE experiments made with the view of determining the spectrum of fluorine were carried out in the following manner. A beautiful little piece of platinum apparatus was constructed, consisting of a wide tube, brightly polished inside and supported vertically. It was closed at each end by a platinum cap, through each of which passed a stout electrode rod. Each rod was in turn connected with one of the wires from a Ruhmkorff coil, worked by six Bunsen cells. Two pairs of these rods, which served for the passing of the spark, were employed alternately, one pair made of platinum and the other of gold, so that the lines due to the terminals could be eliminated. In order to permit the spectroscopic observation of the spark, a short horizontal tube of the same diameter was attached at the middle of the vertical tube, opposite to the two terminals; the open front end of this horizontal tube was closed with a window of perfectly colourless fluor-spar. Narrow entrance and exit tubes were also attached near the ends of the vertical tube in order to enable the apparatus to be filled with any gas at pleasure. The spectrum given by passing the spark between platinum terminals in an atmosphere of nitrogen was first observed; then the nitrogen was displaced by fluorine, and the spark again passed and observed. The two observations were then repeated with terminals of gold. The positions of the lines in the spectrum of fluorine thus obtained were finally confirmed by observations of the dissociation spectra of hydrofluoric acid and the gaseous fluorides of silicon, carbon, and phosphorus. The results show that the spectrum of fluorine consists of thirteen bright red lines, whose positions have previously been given in a preliminary note by M. Moissan, and which will be found in NATURE, vol. xlv. p. 623.

THE additions to the Zoological Society's Gardens during the past week include a Toque Monkey (*Macacus pileatus* ♀) from Ceylon, presented by Mr. John Bell; a Vervet Monkey (*Cercopithecus lalandii* ♂) from South Africa, presented by Mr. R. J. White; a Lesser Sulphur-crested Cockatoo (*Cacatua sulphurea*) from Moluccas, presented by Mr. J. Buckingham; a White-tailed Sea Eagle (*Haliaeetus albicilla*) from Asia Minor, presented by Sir H. F. de Trafford, Bart., F.Z.S.

## OUR ASTRONOMICAL COLUMN.

STONYHURST DRAWINGS OF SUN-SPOTS AND FACULÆ.—A little more light on the relation of faculæ to spots is contained in a paper communicated by the Rev. Walter Sidgreaves to the Royal Astronomical Society in December 1891. None of the drawings of solar phenomena made at Stonyhurst under the late Father Perry's direction afforded a clear instance of faculæ preceding the birth of a spot. Neither was there any positive evidence of the birth of a spot before the appearance of faculæ; while every spot of importance was attended from the beginning with at least a small surrounding of faculæ. No absolute priority of one or the other could therefore be regarded as proved. During the minimum of 1889, however, Father Sidgreaves observed two cases in which faculæ undoubtedly appeared before any trace of a spot could be detected. "On June 29, a small patch of faculæ was sketched near the eastern limb, in latitude  $-40^{\circ}5$ , and in longitude  $25^{\circ}2$ ". There was no trace of a spot in the neighbourhood, and neither spot nor faculæ had been seen near the position for years. On the following day a small round spot appeared in latitude  $-40^{\circ}3$ , and longitude  $25^{\circ}2$ —that is, in the midst of the faculæ, the faculæ on this day being visible only just close round the spot." A similar development was recorded at the end of July, in latitude  $-22^{\circ}$ , and longitude  $155^{\circ}$ . Both the faculæ and spots were new, and clearly distinguished; hence, so far as these observations are concerned, their evidence clearly indicates that the birth of some spots is preceded by the appearance of faculæ.

SOME APPARENTLY VARIABLE NEBULÆ.—Mr. Lewis Swift, in his ninth catalogue of new nebulæ discovered at the Warner Observatory (*Astr. Nach.*, 3004), noted his inability to re-find a nebula previously seen in R.A. 3h. 36m. os., Decl.  $95^{\circ}2'1$ . A further examination of the region led this observer to suspect that the object formerly located in the position given must have been a comet (*Astr. Nach.*, 3014). Dr. Dreyer has looked up the observations of nebulæ in the region in question, and the information thus obtained leads him to conclude that the object is most probably a variable nebula (*Monthly Notices*, December 1891). The nebula appears to have been visible in 1827, 1848, 1850, 1851, 1856, and 1889, while it was not seen in 1785, 1855, 1864, 1865, 1872, 1875, 1877, and 1890, although it was specially looked for on two or three of these occasions. The two nebulæ  $\lambda$  229 and  $\lambda$  882, which Prof. Winnecke found were periodically variable (and his observations were supported by later ones made by other observers), are believed by Dr. Dreyer to owe their apparent fluctuations of light to disturbing atmospheric influences.  $\lambda$  1452 is a similar diffused nebula with slight condensation, which Sir John Herschel suspected to be variable. But in this case, also, conclusive evidence of variability is wanting.

## THE CRYSTAL PALACE ELECTRICAL EXHIBITION.

THE Electrical Exhibition at the Crystal Palace was opened on Saturday last. It is an Exhibition of great interest, not only to electricians but to the public, and should do much to enlighten ordinary visitors as to the methods and results of electrical science. At the present stage we need refer only to some parts of the display. When the Exhibition is complete, we shall give a fuller account of the principal exhibits.

Much attention will, of course, be devoted to the section containing the generating machinery. Every important type of generating apparatus is shown in this department. Among the large exhibits is a 350 horse-power Davey, Paxman engine, capable of driving a powerful Kapp dynamo; and Messrs. Crompton and Co. exhibit a dynamo combined with a Willans engine of 200 horse-power—the dynamo being capable of running nearly 4000  $\frac{1}{2}$  candle-power glow lamps. There are many gas-engines, some of which are shown by Messrs. Crossley Brothers, the original proprietors of the Otto gas-engine. Other exhibitors are the British Gas Engine Company, with cycle engines; Messrs. Dick Kerr and Co., with the Griffin gas-engine; Messrs. J. E. H. Andrew and Co., with the Stockport gas-engine; and Messrs. Day and Co., with a new form of gas-engine. All of these engines are used to drive dynamos of various makers.

A most interesting exhibit is sent by the Postmaster-General, who displays a complete set of telegraphic apparatus. A large

projector or search-light is shown by Messrs. Crompton and Co., who also exhibit, among other things, an electric crane capable of hoisting about a ton. No fewer than 10,000 glow lamps in one group are shown on a wire screen by the Edison-Swan Company, and arc lights, poles, regulators, and samples of submarine cables are displayed by Messrs. Siemens Brothers. A model of an electric launch built for use on the Thames is included among the exhibits of Messrs. Woodhouse and Rawson; and a full-sized electric tram-car is shown by the Brush Electrical Engineering Company, who have also in the Exhibition various dynamos, arc lamps, and other objects.

The exhibits in connection with telephony cannot fail to attract notice, and will do more than any amount of verbal explanation to make its principles intelligible. The National Telephone Company are arranging rooms where London operatic and other performances may be heard by visitors on payment of a small fee; and two stands belonging to the Consolidated Telephone Company, one in the nave, and another in the gallery, are connected by telephone.

Messrs. Croggon and Co. show lightning conductors of the latest type applied to a model church, in connection with which a peal of bells are rung by electricity from a keyboard. Various styles of fittings for domestic electric lighting are displayed in a series of rooms in the galleries; and these will no doubt attract very general attention. The Medical Battery Company show well how electricity is applied in various departments of medical practice.

The Exhibition has been organized with so much care, and on so great a scale, that it is sure to be widely appreciated.

## THE SMITHSONIAN INSTITUTION.

PROF. S. P. LANGLEY, Secretary of the Smithsonian Institution, has submitted to the Board of Regents his Report for the year ended June 30, 1891. It includes, among other things, an account of the work placed by Congress under the charge of the Institution in the National Museum, the Bureau of Ethnology, and the National Zoological Park.

As in a previous Report, Prof. Langley refers to the fact that owing to the changing value of money the purchasing power of the Smithsonian Fund, in the language of a Committee of the Regents, "while nominally fixed, is growing actually less year by year, and of less and less importance in the work it accomplishes with reference to the immense extension of the country since the Government accepted the trust"; and he urges that the fund should be enlarged, "if only to represent the original position of its finances relatively to those of the country and institutions of learning." If we may judge from the general tone of the Report, the required increase is more likely to be obtained from private benefactors than from the Government. Quite lately, as we recorded at the time, the Institution obtained from Mr. Thomas G. Hodgkins, of Setauket, Long Island, a handsome donation of 200,000 dollars.

By reducing expenses in other directions, the Institution has been able to revert to its early practice of aiding investigators carrying on original research. Among the special grants may be named that of 500 dollars to Prof. A. A. Michelson, of Clark University, for continuing his important work upon a universal standard of measure founded on the wave-length of light; also a sum of 600 dollars placed at the disposal of Prof. E. W. Morley, to procure a special apparatus for determinations of the density of oxygen and hydrogen, an investigation requiring extreme precision and delicacy of manipulation, and promising results of wide application; while a sum of 200 dollars was placed at the disposal of Dr. Wolcott Gibbs, for investigations at his laboratory in Newport upon chemical compounds.

To Prof. E. S. Holden, Director of the Lick Observatory, California, a grant of 200 dollars was made, to assist in perfecting his apparatus for securing photographs of the moon. The results of his studies in this field Prof. Holden has offered to place at the disposal of the Smithsonian Institution for publication at some future day, should it seem desirable.

Prof. Pickering, Director of the Harvard Observatory, has also placed at the disposal of the Institution for publication a very valuable series of photographs of the moon, which have been secured at the Harvard Observatory, and which will be supplemented by photographs to be taken at the Harvard Observatory high-altitude station in the mountains of Peru.

The Director of the Paris Observatory, Admiral Mouchez,

has likewise promised his co-operation in securing lunar photographs of the highest degree of excellence now attainable.

With the aid of these three prominent Observatories, which have given especial attention to the subject of lunar photography, it is proposed to prepare a volume representing upon a large scale the best results that can be secured, thus placing on record a detailed description of the lunar surface, the value of which for comparison with observations and photographs of the planet can scarcely be over-estimated.

In furtherance of the plan for the establishment of standard sizes of screws and of diameters of tubing, &c., for astronomical and physical apparatus—a subject which has received the attention of Committees of the National Academy of Science, as also of the American Association for the Advancement of Science—a few standards have been tentatively adopted, and copies of these are attainable by all interested in securing uniformity in this class of work.

No memoir was added to the Smithsonian "Contributions to Knowledge" during the year, but a paper presenting an account of new experiments in aero-dynamics by Prof. Langley was in course of preparation. These investigations were made at private charge, but it is in accordance with a policy long ago counselled by the Board of Regents that they should be published in a volume of the Institution's "Contributions."

A statement relating to the establishment of an Astro-physical Observatory as a part of the Smithsonian Institution has already appeared in NATURE (vol. xlv. p. 254). With regard to this Observatory, Prof. Langley recalls the fact that preparations for it had been made by the late Secretary, Prof. Baird. A special interest was taken in the proposed Astro-physical Observatory by the late Dr. J. H. Kidder, formerly Curator of Exchanges in the Smithsonian Institution, and the sum of 5000 dollars was received from his executors for this purpose. A like sum of 5000 dollars was presented personally to the Secretary by Dr. Alexander Graham Bell for prosecuting physical investigations, and particularly those upon radiant energy; and this sum was, with the consent and approval of the donor, placed to the credit of the Smithsonian Institution upon the same footing as the Kidder bequest. Congress was asked to appropriate 10,000 dollars for annual maintenance, and this sum was granted, and became available on July 1 last.

Speaking of the National Museum, Prof. Langley notes that at the close of the fiscal year the present building had been occupied one decade, and that during that period the total number of specimens of all kinds catalogued and ready for exhibition or study had increased from about 193,000 to more than 3,000,000. This rate of growth, as he says, is "probably unprecedented in the history of Museums." The development of the collections has not, however, proceeded "in such a symmetrical and consistent manner as is essential to the necessities of the work"; and such is the competition for "material," that the Museum is often unable to hold its own, not only with foreign Governments and with local Museums in other American cities, but even with private collectors. More space and a larger staff of curators are urgently needed.

Some interesting statements are made with regard to the work of the Bureau of Ethnology. At the close of the last fiscal year, specific exploration of the mound area by the United States ceased, except so far as it was found necessary to correct errors and supply omissions. A large part of the results of the work of several past years is in print, though not yet issued. A plan of general archaeological field work has been practically initiated by a systematic exploration of the tide-water regions of the District of Columbia, Maryland, Virginia, and the Ohio Valley, which determined among other points of interest that the implication of great antiquity to forms of stone implements of America which have hitherto been classed with European palæoliths in age as well as in fabrication has not been substantiated by the ascertained facts.

Careful exploration of the Verde Valley in Arizona followed that before made of other parts of the large south-western region of the United States in which the presence of many extensive ruins has given rise to fanciful theories. The data as classified and discussed have shown that the hypothesis of a vanished race enjoying high civilization, which has been proposed to account for the architecture of the ruined structures is unnecessary.

The attention already given to Indian languages has been continued, in recognition of the fact that some of them are fast passing beyond the possibility of record and study, and that the

ethnic classification of all of the Indian tribes can be made accurate only through the determination of their linguistic divisions and connections. The studies upon aboriginal mythology and religious practices have also been continued, with special attention to the ghost dances and "Messiah religion," which have produced important consequences bearing upon the problem of proper national dealing with the Indians. Official misconception of their religious philosophy, which has been forcibly transmuted by the absorption of Christianity so as to present more apparent than actual antagonism to civilization, has occasioned needless loss of life and treasure.

With regard to the National Zoological Park, Prof. Langley says the primary object for which Congress was asked to establish it was to secure the preservation of those American animals that are already nearly extinct, and this object it was thought would be best attained by the establishment of a large inclosure in which such animals could be kept in a seclusion as nearly as possible like that of their native haunts. Congress has been so unwilling to provide the necessary funds that the Smithsonian Institution has found it hard to realize the original design. Nevertheless, the development of the Park proceeded steadily during the year, as few changes as possible being made in its natural features. Trees have been planted in different parts, in some places for ornament, in others to secure the proper seclusion of animals; and a considerable area of open land has been prepared for lawn and pasture grounds. Near what is for the present the principal entrance is a disused quarry, from which arise precipitous cliffs and bold rocky ledges. It seemed particularly well fitted for the construction of dens and yards for bears. A series of caverns has been blasted in the rock and inclosed by a stout iron fence. Within the fence are large and commodious yards, in which have been constructed bathing pools, with water flowing constantly from a large spring outside the Park. The result has been a place admirably adapted for the health and general welfare of the animals, as well as a most picturesque and striking feature.

Already the establishment of a National Zoological Park under the management and guidance of the Smithsonian Institution has attracted the attention of similar institutions and of naturalists in other countries, and liberal offers of gifts and exchanges have been made.

From Sumatra, from the islands of the Pacific, from the shores of Alaska, and from American national parks, have come offers of gifts or terms of purchase, but it has been necessary to defer acceptance of all these offers owing to lack of funds even to pay for transportation.

## SOCIETIES AND ACADEMIES.

LONDON.

Chemical Society, December 17, 1891.—Dr. W. H. Perkin, F.R.S., Vice-President, in the chair.—The following papers were read:—The composition of cooked vegetables, by Miss K. J. Williams. The vegetables examined after cooking were the artichoke (Jerusalem), broad bean, haricot bean, beetroot, cabbage, carrot, cauliflower, celery, cucumber, lettuce, mushroom, onion (Spanish), parsnip, pea (green), potato, radish, salsify, scarlet-runner, sea-kale, spinach, tomato, turnip, and vegetable marrow. Ultimate analyses of the cooked vegetables were made, and their heats of combustion determined. The woody fibre, cellulose, fat, and the carbohydrates convertible into glucose were also estimated.—Metallic hydrosulphides, by S. E. Linder and H. Picton. The authors have investigated the sulphides of copper, mercury, arsenic, antimony, cadmium, zinc, bismuth, silver, indium, and gold; and find that, with the single exception of bismuth, all these metals form hydrosulphides of a more or less complicated character. These compounds, when treated with acids, in most cases lose part of their sulphuretted hydrogen, and form still more complicated hydrosulphides. Copper forms a soluble hydrosulphide possessing the composition  $7\text{CuS}\cdot\text{H}_2\text{S}$ ; this, on treatment with acetic acid in presence of excess of sulphuretted hydrogen, yields a substance of the composition  $9\text{CuS}\cdot\text{H}_2\text{S}$ ; if no excess of sulphuretted hydrogen be present, the compound  $22\text{CuS}\cdot\text{H}_2\text{S}$  is obtained. Hydrochloric acid produces still further condensation. Mercuric sulphide forms products approximately represented by the formulæ  $3\text{HgS}\cdot\text{H}_2\text{S}$  and  $62\text{HgS}\cdot\text{H}_2\text{S}$ . The latter formula represents the substance obtained in presence of acid, and is a very stable substance. Zinc sulphide solution



obtained from the hydroxide contains about 14 per cent. excess of sulphur as sulphuretted hydrogen; in presence of acetic acid a product represented approximately by the formula  $12ZnS, H_2S$  is obtained. The authors consider that their results support the conclusion that the metallic sulphides are in most cases polymeric of very high molecular weight.—The physical constitution of some sulphide solutions, by H. Picton. The author has specially examined the solutions of mercuric, antimonious, and arsenious sulphides, and finds that in each case the sulphide is present in the form of very finely divided particles. In the "solution" of mercuric sulphide particles are visible under the microscope with a magnifying power of 1000 diameters, and are not diffusible even in the absence of a membrane. Arsenious sulphide may exist in "solution" in three distinct types of subdivision. In the first solution, the particles are just visible. In the second, the particles are smaller but not diffusible, and scatter and polarize a beam of light sent through the solution. The third solution is diffusible in the absence of a membrane, but the optical behaviour shows that particles really exist in the solution.—Solution and pseudo-solution, Part I., by H. Picton and S. E. Linder. The authors consider that there is a continuous series of grades of solutions passing without break from a crystallizable solution to one containing the substance in a state of fine subdivision. They regard the very finely divided particles in the lower grades of solutions—colloid solutions—as large molecular aggregates retaining many of their molecular properties. On passing up through the different grades of solution, the particles become smaller, and the forces holding them in solution become more definitely those of chemical attraction. A new property is described, which holds for a large range of solutions extending from pseudo-solutions to crystallizable solutions. This property consists in the repulsion of the dissolved substance as a whole from one of the electrodes of a battery immersed in the solution. Thus, in the case of colloidal arsenic sulphide, the sulphide aggregates are repelled from the negative electrode; they are also repelled, though much less strongly, from the positive electrode. An exactly similar phenomenon is observed in the case of the crystallizable colouring-matter Magdala-red when dissolved in absolute alcohol, the repulsion being, however, from the positive electrode, no perceptible repulsion from the negative electrode being observable. This property is of much interest in itself, but also as exhibiting similarities between the different grades of solution.—The charge proceeding in an acidified solution of sodium thiosulphate when the products are retained within the system, by A. Colefax. The action of acids on sodium thiosulphate was investigated by allowing the action to proceed for a known time, then titrating with standard iodine solution, and subsequently determining the amount of acidity of the solution. The author concludes that the change proceeding in an acidified solution of sodium thiosulphate, when the products, viz. sulphurous acid and sulphur, are retained in the system, is a reversible one, a limit being reached a certain time from the time of acidification. The value of this limit is affected by the state of concentration, the ratio of the mass of acid relatively to the sodium thiosulphate, the nature of the acidifying acid, and the temperature. Sulphurous acid cannot prevent the decomposition of thiosulphuric acid. The presence of both products of the change in the system seems essential to the attainment of a limit value, for sulphurous acid, when initially free in the system at the time of acidification, has but little influence upon the values expressing the extent of the chemical change. A higher temperature favours the interaction of sulphurous acid and hydrogen and sodium thiosulphates; but this is a secondary change, which proceeds at lower temperatures with extreme slowness. Spring's statement that sodium trithionate is formed by the interaction of iodine, sodium sulphite, and sodium thiosulphate, seems to be wrong: the author finds that on adding a solution of these two salts to one of iodine no sodium trithionate is produced; the sodium sulphite is completely oxidized to sulphate.—The action of sulphurous acid on flowers of sulphur, by A. Colefax. Contrary to the statement of Debus, sulphurous acid acts on flowers of sulphur at the ordinary temperature, producing thiosulphuric acid and a polythionic acid, probably trithionic acid; no pentathionic acid was found. The action occurs even in the dark, and proceeds much more rapidly at a temperature of  $80^{\circ}$ – $90^{\circ}$ . Water has no action on flowers of sulphur, either at ordinary temperatures or at this higher temperature.—The  $\alpha$  and  $\beta$  modifications of chlorobenzene hexachloride, by F. E. Matthews. A mixture of these

two substances with oily products is obtained by passing chlorine gas through chlorobenzene in presence of dilute caustic soda. They are both colourless crystalline substances, which on heating, either alone or with alcoholic potash, give a quantitative yield of 1 : 3 : 4 : 5 tetrachlorobenzene. The  $\beta$  modification of chlorobenzene hexachloride,  $C_6H_2Cl_4$ , melts at about  $260^{\circ}$ , and is more stable and less volatile with steam than the  $\alpha$  compound, which melts at about  $146^{\circ}$ .—The sulphochlorides of the isomeric dibromonaphthalenes, by H. E. Armstrong and E. C. Rossiter. The sulphochlorides of five of the dibromonaphthalenes have been investigated. It is to be noted that, while the dibromonaphthalenes all have higher melting-points than the corresponding dichloro-derivatives, no such relation holds between the sulphochlorides of corresponding dichloro- and dibromonaphthalenes.—The action of alcohols on sulphonic chlorides as a means of producing ethereal salts of sulphonic acids, by H. E. Armstrong and E. C. Rossiter. The authors find that the ethereal salts of several but not all of the dibromonaphthalenesulphochlorides may be prepared by simply boiling them with dehydrated alcohol.—The action of bromine on  $\alpha$  and  $\beta$  bromonaphthalene, by H. E. Armstrong and E. C. Rossiter. The authors have succeeded in resolving into its constituents the mixture of dibromonaphthalenes obtained on brominating naphthalene with two molecular proportions of bromine.—The action of bromine on a mixture of ortho- and paraitro- $\alpha$ -acenaphthalide, by H. E. Armstrong and E. C. Rossiter. When a mixture of ortho- and paraitro-acenaphthalides is brominated, the ortho-compound, not the para-, as previously supposed, is alone attacked.—Camphrone, a product of the action of dehydrating agents on camphor, by H. E. Armstrong and F. S. Kipping. Several chemists have described camphrone,  $C_9H_{16}O$ , as a product of the action of sulphuric acid on camphor; the properties of this substance, however, as given by different chemists, show great variations. The authors, on preparing the substance and purifying it by means of its hydrazone, find its composition to be, not  $C_9H_{16}O$ , but probably  $C_{10}H_{18}O$ .—Metaxylenesulphonic acids, Part II., by G. T. Moody. When acetmetaxylid (1 : 3 : 4) is sulphated, metaxylinidinesulphonic acid ( $Me_2 : NH_2 : SO_3H = 1 : 3 : 4 : 6$ ) is obtained in slender needles soluble in water. On diazotizing, and boiling with alcohol, it yields ethoxymetaxylenesulphonic acid; if the diazo-compound be boiled with hydrobromic acid, the corresponding bromoxylene-sulphonic acid is obtained in slender needles. The salts of the above acids are described.—The action of propylene bromide on the sodium derivatives of ethylic acetoacetate and ethylic benzoacetate, by W. H. Perkin, Jun., and J. Stenhouse. The preparation and properties of the ethyl salts of acetylmethyltrimethylenecarboxylic acid, methylidialdiadipic acid, and benzoylmethyltrimethylenecarboxylic acid, and their derivatives, are described.—Derivatives of tetramethylene, by W. H. Perkin, Jun., and W. Sinclair. The authors have prepared the monobromo-derivative of tetramethylenecarboxylic acid. Its hydroxy-, acetoxy-, and ethoxy-acids are also described, together with tetramethylene, methyl, and ethylketones and their reduction products.

Geological Society, December 23, 1891.—W. H. Hudson, F.R.S., Vice-President, in the chair.—The following communications were read:—On part of the pelvis of *Palaeanthus*, by R. Lydekker.—On the gravels on the south of the Thames from Guildford to Newbury, by Horace W. Monckton. The author stated that the greater part of the hill-gravel in the district referred to belonged to the Southern Drift of Prof. Prestwich, and that the valley-gravels for the most part consisted of material derived from the Southern Drift. Small patches of Westleton Shingle and Glacial Gravel occurred near Reading and Twyford. He divided the Southern Drift into three classes:—(1) Upper Hale type, characterized by the abundance of small quartz pebbles and the scarcity of chert. (2) Chobham Ridges type, with abundance both of small quartz pebbles and chert. (3) Silchester type; quartz scarce, and chert very rare or altogether absent. He described the localities at which these types occurred and their limits of distribution, and then referred to the Glacial Gravels of the Tilehurst plateau, which he believed to have been deposited before the excavation of the valley of the Thames between Reading and Goring. The author then dealt with the valley-gravels, which he believed to be mainly derived from the hill-gravels of the immediate neighbourhood, and showed how the various types of hill-gravel had contributed

materials for the valley-gravels. He explained that, with the possible exception of the Westleton Shingle, he entirely rejected the theory of marine action in connection with the formation of these gravels, and thought that the Glacial Gravels were probably for the most part due to floods during melting of large quantities of ice. The remaining gravels, he believed, had been spread out by water in valleys; as denudation proceeded, the gravel, by protecting the ground upon which it lay, came to stand out as the capping of the plateaux and hills; as the gravel itself was denuded, the materials were carried to lower levels, forming new gravels; and this process has been repeated up to the present time. He explained that Prof. Rupert Jones and Dr. Irving had already adopted this theory in part, but that he differed from them in the entire exclusion of marine action. After the reading of this paper there was a discussion, in which the Chairman, Mr. W. Whitaker, Dr. Hicks, Mr. R. S. Herries, Prof. Grenville Cole, and Mr. Monckton took part.—The Bagshot Beds of Bagshot Heath, by Horace W. Monckton.

## PARIS.

**Academy of Sciences, January 4.**—M. Ducharte in the chair.—On an abnormal mode of propagation of waves, by M. H. Poincaré.—Remarks on the mechanism of the fixation of nitrogen by the soil and plants, *à propos* of a reply by MM. Schlessing and Laurent, by MM. Ar. Gen. Gautier and R. Drouin.—Note on the late Herr Kronecker, by M. Hermite. This is an obituary notice on Herr Kronecker, the renowned mathematician, who died at Berlin on December 29, 1891, after a short illness.—On electro-capillary phenomena and differences of potential produced by contact, by M. Gouy. In order to obtain some new information as to contact force, the author has measured the surface tensions of more or less polarized liquid amalgams, in comparison with mercury. The first experiments were made with amalgams containing 1/1000 part of zinc, cadmium, lead, tin, bismuth, silver, and gold. And the results lead to the provisional statement that in a system consisting of non-polarized mercury, acidulated water, and an amalgam of 1/1000 more or less polarized, the superficial tension of the amalgam is a function of the apparent difference of potential between the amalgam and the mercury.—The direct combination of nitrogen with the alkaline-earth metals, by M. Maquenne. The metals employed have been used under the form of electrolytic amalgams. They unite rapidly with nitrogen when heated in a current of that gas, in the absence of carbon and its compounds; there is thus no intermediate formation of a metallic carbide. The ease with which the combination takes place may lead to a new interpretation of the synthesis of alkaline-earth cyanides by the simultaneous action of nitrogen and carbon on the corresponding bases.—Nitration of hydrocarbons of the methane series, by M. Konovaloff. The normal hydrocarbons of the methane series may be nitrated by weak nitric acid, and give as principal products secondary nitro compounds. The yields are relatively good, and the method may be used to prepare secondary nitro-paraffins. Corresponding amines and ketones are obtained by reduction of these products.—On the embryology of *Sagittia*, by M. S. Jourdain.—Influences of electric discharge during thunderstorms on apparatus registering terrestrial magnetism, by M. Em. Marchand. An examination of the tracings drawn by the registering magnetometers at Lyons Observatory since 1887, and the records of thunderstorms, establish a connection between lightning discharge and magnetic disturbances which has been frequently noted. Seventy-three lightning discharges had their time of occurrence and approximate distance recorded during the last five years. Forty of these were accompanied by well-marked disturbances of the declination curve; in fifteen cases the oscillatory movements were slight, but could be easily found when the time of discharge was known; thirteen cases were doubtful; and in five cases absolutely no trace of an abnormal oscillation could be detected. No simple relation appears to exist between the distance of the discharge and the amplitude of the oscillation they produce. Some very violent thunder-claps have only been accompanied by slight magnetic perturbations, whilst others, far more feeble and distant, have produced very large ones.—On the absolute values of the magnetic elements on January 1, 1892, by M. Th. Moureaux. The following are the values at the Parc Saint-Maur Observatory, deduced from the mean of the hourly observations obtained on December 31, 1891, and

January 1, 1892, and referred to the absolute measures made on December 27, 29, and 31, and on January 2—

Elements.	Absolute values on January 1, 1892.	Secular variation in 1891.
Declination ... ..	15° 30' 7	-5' 2
Inclination ... ..	65° 9' 0	-1' 6
Horizontal force ... ..	0 19580	+0 00026
Vertical force ... ..	0 42278	+0 00006
Total force ... ..	0 46592	+0 00016

—On the soundings of the Bourget Lake, and some other lakes in the Alps and the Jura, by M. A. Delebecque.

## BOOKS, PAMPHLETS, and SERIALS RECEIVED.

**BOOKS.**—Elements of Agriculture: Dr. W. Fream (Murray).—Annuaire, 1892, par le Bureau des Longitudes, Paris (Gauthier-Villars).—Monograph of the British Cleadre, Part 2: G. B. Buckton (Macmillan).—Richard Wiseman: Surgeon-General Sir P. Longmore (Longmans).—U.S. Commission of Fish and Fisheries; Part xv., Report of the Commissioner for 1891 (Washington).—Observations made at the Blue Hill Meteorological Observatory, Mass., U.S.A., in the Year 1890 (Camb., Mass. Wilson).—Nature's Fairy-Land: H. W. S. Worsley-Benson; 4th edition (E. Stock).—A Cyclopædia of Nature Teaching (E. Stock).—A Treatise on the Legislation of the Great Arteries in Continuity: C. A. Balance and W. Edmunds (Macmillan).—Rand, McNally, and Co.'s Indexed County and Railroad Pocket Maps and Shippers' Guides of Connecticut, Massachusetts, Pennsylvania, and Washington (Stanford).—Guide to the Examinations in Magnetism and Electricity, and Answers to Questions: W. J. Harrison (Blackie).—The Universal Atlas, Part 10 (Cassell).

**PAMPHLET.**—The Evolution of Mind in Man: H. B. Medlicott (Kegan Paul).

**SERIALS.**—Bulletin of the N.Y. Mathematical Society, vol. i., Nos. 2 and 3 (New York).—Journal of the Asiatic Society of Bengal, vol. lii., Part 2, 1890; Supplement No. 2 (Calcutta).—La Nuova Scienza, vol. vi, fasc. v. (Udine, Umbria).—Journal of the College of Science, Imperial University of Japan, vol. iv, Part 2 (Tokyo).—Zeitschrift für wissenschaftliche Zoologie, liii. Band, 2 Heft (Williams and Norgate).—Notes from the Leyden Museum, vol. xlii, Nos. 3 and 4 (Williams and Norgate).—The Record of Technical and Secondary Education, No. 2 (Macmillan).—Journal of Physiology, vol. xii., Nos. 5 and 6 (Cambridge).—Journal of the Royal Microscopical Society, December (Williams and Norgate).

## CONTENTS.

	PAGE
The Chemistry of Paints and Painting. By Dr. Hugo Müller, F.R.S.	241
Poincaré's Thermodynamics. By P. G. T.	245
Insect Pests	246
Our Book Shelf:—	
Wrightson: "Farm Crops"	247
Smith: "Arithmetic for Schools."—W.	247
Bishop: "Journeys in Persia and Kurdistan"	248
Maycock: "A First Book of Electricity and Magnetism"	248
Macmillan: "A Cyclopædia of Nature Teachings"	248
Letters to the Editor:—	
On the Attitudes of the Zebra during Sleep, and their Influence on the Protective Value of its Stripes.—H. W.	248
The Migration of the Lemming.—Prof. George J. Romanes, F.R.S.	249
Destruction of Immature Sea Fish.—Ernest W. L. Holt	249
A New Precessional Globe.—Dr. K. Haas	250
Simple Proof of Euclid II. 9 and 10.—Percival and Co.	250
The Alleged Discovery of a Bacillus in Influenza. By H. F. P.	250
On the Matter thrown up during the Submarine Eruption North-west of Pantelleria, October 1891. By Gerard W. Butler; Geo. H. Perry	251
The Spectrum of Iron and the Periodic Law. By John Parry	253
The Growth of the Pilchard or Sardine. By Prof. J. T. Cunningham	255
Science in Japan. By Prof. E. Ray Lankester, F.R.S.	256
Evidence of a Wing in <i>Dinornis</i> . (Illustrated.) By Henry O. Forbes	257
Notes	257
Our Astronomical Column:—	
Stonyhurst Drawings of Sun-spots and Facule	261
Some apparently Variable Nebule	261
The Crystal Palace Electrical Exhibition	261
The Smithsonian Institution	261
Societies and Academies	262
Books, Pamphlets, and Serials Received	264

THURSDAY, JANUARY 21, 1892.

PARKE'S PERSONAL EXPERIENCES IN  
EQUATORIAL AFRICA.

*My Personal Experiences in Equatorial Africa as Medical Officer of the Emin Pasha Relief Expedition.* By Thomas Heazle Parke, Hon. D.C.L. (Durh.), &c. With Map and numerous Illustrations. (London: Sampson Low, Marston, and Company, Limited, 1891.)

A FAIRLY large literature has now seen the light in which we have had numerous details about the expedition sent out for the relief of Emin Pasha. All of the as yet published volumes treating of this subject have been to a very great extent based only on personal experiences, being more or less expanded from notes taken at the time; it thus happens that of the history of this famous expedition it is difficult to obtain any general survey. As a contribution, however, to such a survey this book of Dr. Parke's is welcome. As the medical officer in charge, the exigencies of the many trying circumstances that arose rendered it necessary that he should attach himself most constantly to the sick camp, and so his narrative comes in to tell us of trials and hardships undergone, of which in Stanley's "Darkest Africa" we of necessity heard but little.

In order that one may be able to appreciate the facts enumerated in this volume, the reader should bear in mind that the expedition across Africa was in stern reality several expeditions backwards and forwards through the most trying portion of this continent. Under the leadership of Mr. Stanley the officers selected left England late in 1886, but at the last moment the medical officer in charge was compelled to abandon the expedition, and in Cairo, Stanley, who had seen Parke in Alexandria, where the latter was on duty as a member of the British Medical Staff, appointed him as one of his officers.

Of the journey to Cape Town, and from thence to the mouth of the Congo, little need be said, nor, indeed, are there any special facts of interest about the voyage up the river to Yambuya, where the entrenched camp was formed which was handed over to the care of Barttelot and Jameson. This portion of the journey took four months and a week; there was of course a certain amount of new experiences, some deaths among the native army, some accidents there were both by land and water, but these are all told within a compass of the first seventy pages.

From Yambuya the land journey to the Albert Nyanza commenced, Mr. Stanley taking with him Nelson, Stairs, Jephson, and Parke, intending to return for the rear column, which had instructions to make their way slowly onwards in an eastern direction. Tedious was the progress made, paths had to be cut through the bush, one after another of the leaders and many of the men suffered much from fever. There was plenty of game in the forest, judging by the footprints, but already there was some scarcity of provisions. At Avisibba there was an encounter with the natives, when Lieutenant Stairs was shot in the chest by an arrow, from which peril he recovered, though

it was not until long months afterwards that the broken off arrow's head was extracted by Dr. Parke. This part of the journey took four weeks, but after a day's rest at Avisibba the march was again resumed, the next halting stage being at an Arab encampment, marked in the map as Ugarrowa, from the name of the chief. This march was still through the forest, but along the course of the river, and it lasted over four weeks. During it the effect of the cold and wet weather began to tell upon the Zanzibaris; the constant tramping through the forest was also extremely depressing, malarious marshes and swamps had to be waded through, and even worse, the camps at night had often to be pitched by their very edges. To all these troubles the want of food was added; of animal food there was almost none. At times hornets and ants came in swarms, and were more dreaded than the arrows of the natives. At Ugarrowa's camp a number of men had to be left, while the rest of the party went on without delay to Ipoto. Within a fortnight afterwards the hardships told so severely on the travellers that when the river navigation came completely to an end at the junction of the Ihuru and the Ituri to form the Aruwimi, itself a large confluent of the Congo River, fifty-two men who were unable to march were left behind with Captain Nelson, himself an invalid. This dreadful spot was afterwards known as Nelson's Starvation Camp. The rest of the party pressed on, and in ten days reached Ipoto, but through all these days there seems to have been but one great struggle to support life with a minimum quantity of food, men dropt from starvation; their rifles and loads were then taken by others, and they were left.

At Ipoto there were three chiefs, head men to Abed Bin Salim, and the people were all Manyema. Food was to be had—goat flesh, fowls, Indian corn, and beans—and nine days were spent here before the next move lakewards. Jephson left on October 26, 1887, to return to bring Nelson and all that might be surviving of his men. Mr. Stanley on the following day started for the lake, leaving Parke behind to attend to the sick army that Jephson was to bring up from Nelson's Starvation Camp, and then Jephson was to press on after his chief with all the then available men. Parke now found himself little better than a prisoner in the hands of the Manyema, with the prospect in store of his troubles being increased by the return of the invalids with Jephson, and the additional horror of knowing that all he obtained from the Manyema in the way of food could only be paid for by drafts on an uncertain future. On November 3 Jephson came into camp with Nelson, but with only three or four of the band of fifty-two who had been left behind at Starvation Camp. This frightful destruction from starvation took place at a spot within, even for feeble men, a three days' journey from their friends at Ipoto. On November 7 Jephson left Ipoto with forty-eight men, leaving Parke and Nelson behind with twenty-four cripples and three boys. For nearly three months long these men had to live through the greatest miseries and privations; sickness added to semi-starvation made existence almost insupportable, and the reading of this portion of Parke's notes is about the most saddening in the book. It is a pity that it should be interrupted by some eighteen pages of a very second-rate account of "bac-

teriology"; but we almost forgive this irrelevant intrusion in admiration of the way in which he bore his many and great trials; and we find ourselves happy when we read that on January 25, 1888, Stairs appeared on the scene with a column of fine-looking men, fat, muscular, and glossy-skinned, these being the very same who had left Ipoto as skeletons only three months ago.

Ipoto was left without regret, but with friendly farewells, on January 27. Stairs's able men had the boat to carry; the feeble folk crawled on as best they could; some days two miles, other days three or four, or even six, would be got over; one day one man would lie down and die, another day two would follow the example; but at last, on February 8, Fort Bodo was gained.

Mr. Stanley and Jephson had it in excellent order; six tons of Indian corn were stored up in the granary; there was a rich supply of plantains over a radius of a couple of miles; there was a good water supply, and even a stock of milch cattle, three cows, and about twenty goats. The camp was in a clearing of the forest; a plan of it will be found in "Darkest Africa"; there was one road leading to it from Manyuema, and another which led in the direction of the Albert Nyanza; the huts were good; each had a good veranda, which furnished some shade. While arrangements were being made for Mr. Stanley's second visit—this time with the boat—to the lake, he took seriously ill; and it was a month before, thanks to his constitution and the care of his doctor, he was again able to think of advancing. Nelson was then left in care of the fort. Stairs had been sent back to Ugarrowa's camp to bring up the men who had been left there, and he was to abide with Nelson at Fort Bodo until Stanley's second return.

On April 2, 1888, the second march to the Albert Nyanza began; the force numbered 122. In eight days the Ituri River was reached, and on the next day the open plain, and for the first time for twelve months Parke was out of the dark forest.

We need not dwell on the journey through the hilly country, on the first views of the Mountains of the Moon, and of the lake, nor of the meeting with Emin Pasha, for all these facts have been related at greater length in Mr. Stanley's volumes, but it being arranged that Stanley should return to Yambuya for the rear column, and bring them up to the lake before the general return to Zanzibar should be commenced, he and Dr. Parke started back through the forest on May 24, leaving Jephson behind with Emin Pasha; the men at this time appear to have been in good condition, so that Fort Bodo was reached in about ten days' march; the natives on the route back were friendly, and one day was devoted to helping some of the chiefs in a feudal fight.

At Fort Bodo, Stairs and Nelson were found "looking fit," but many of the people, some of whom had been brought by Stairs from Ugarrowa's camp, were suffering from fever and bad ulcers. From this fort Mr. Stanley departed on his memorable journey to Yambuya on June 16, leaving Stairs in command at Fort Bodo, with Nelson and Parke to assist. Fifty-seven men were left in their charge, and Stanley's directions were that when Jephson came to Fort Bodo, which he had arranged to do within two or three months, then all the party were, as soon as could be, to return with all the loads to the lake,

and remain there with Emin Pasha until Stanley came up from Yambuya. This part of the volume is full of interest, as it gives us for the first time an idea of how a period of just over six months was spent in this fort; for, as matters turned out, Jephson with Emin Pasha being made prisoners, was unable to come to them, and they waited in some impatience, until at last the leader himself appeared with the remnant of the party from Yambuya. Parke accompanied Stanley on his way to Yambuya as far as the Manyuema camp (Ipoto), to collect some of the goods which had been left behind during his former residence there.

From Ipoto Mr. Stanley went west, and Parke returned to Fort Bodo, bringing with him not only the goods he went back for, but some seed rice, some goats, and, not least, a female dwarf, one of the pygmies, whom he had purchased for a handful of beans, twelve cups of rice, and six cups of corn. He also had full instructions from his chief; among these latter were orders to "Plant, sow, and plant, as though you were going to make a long stay at Fort Bodo. If Jephson comes, well, you can go along with him. If Jephson does not turn up, you have abundance of food for yourselves." It took Parke ten days to get back to Fort Bodo, and on July 6 the long watch began.

By August 9 the men were so broken down by the prevailing ulcers that it was impossible to go out after any game, for there were not enough of them to form a guard; twenty-five were "badly sick" out of the fifty-five. There seems, judging by the statements on p. 256, to have been a somewhat slack surveillance of sanitary matters about the camp, which, from the plan made by Stairs, was one apparently easily kept clean; a stream abounding in small fish ran not far away; but Parke declares that "the Zanzibaris owe a great deal of their physical ill-being to their timidity and laziness." The officers in charge did not by any means escape their share of sickness, and first Parke was laid up, and then Nelson, and lastly, Stairs. On September 5, Ali Jumba came to Stairs and told him that the men proposed, first, that fifteen of the strongest of them should go with one white officer to the edge of the forest, and, if they found the natives friendly, that they should then push on to Emin, asking him to come on and relieve the others at the fort; or, secondly, that all the men should leave the fort, and convey the loads by a system of double journeys, until they should arrive at some good banana plantation, where they should make a camp, and remain until relieved either by Stanley or Jephson. The men made these proposals, because they said they could get little or no food at Fort Bodo, and that they would die of starvation unless some move was made.

On a consultation, it was resolved that neither of these ideas of the men were practicable, and that there was no fear of starvation, as there was corn already in store to furnish a small quantity to each man of the party until the new corn should be reaped. When October came, all hopes of Jephson making his appearance were abandoned, and no thoughts as to the true cause of his non-appearance seem to have entered their minds.

December 18 was the day on which Mr. Stanley said he expected to return to Fort Bodo, and on the 20th he appeared. He was looking careworn and haggard to an extreme degree. Bonny was the only one of the staff

with him ; and there now came the sad story of the sorrowful fate of the rear column. The long confinement in the fort had at last come to an end ; and after but three days, which were spent in getting in stragglers and packing up, Fort Bodo was burnt, and this little oasis of cultivation in the dark forest was abandoned to its fate.

By January 9, 1889, Kandekore was reached, the progress being but slow, owing to the number of sick men, and here Parke was left again in charge of what he calls a "Convalescent Home," with Nelson to keep him company. This "Home" was made fairly comfortable, and was not left until February 12, when Rashid, the head chief of the Zanzibaris, arrived from Mr. Stanley with a number of Zanzibaris and Mazambonis. Parke now heard for the first time of how Emin Pasha and Jephson had been taken prisoners, and had been sent to Refaj. All hands were soon employed procuring food for the next few days' march, and Kandekore was abandoned on the 12th, the party joining Mr. Stanley on February 18.

The much-wished-for journey to the coast commenced on April 10. There was a mixed multitude, old people and quite young children, but they were only well on the march, when a return of the illness which brought Mr. Stanley so near death's door at Fort Bodo, delayed the expedition at Mazzamboni's camp until May 8. Some difficulty was experienced in crossing the Semliki River, which flows into the Albert Nyanza, the graphic account of which crossing will be familiar to the readers of Stanley's volumes. On August 20 the expedition was at Usamiro, a missionary station, where a rest of a couple of days was taken, and at which station Dr. Parke's regular diary ceased, owing to an attack of ophthalmia, which clung to him until he reached the coast. They arrived at Bagamoyo on December 4, 1889, and here the unfortunate accident happened to Emin Pasha, who was fortunate though in this, that Dr. Parke was near him, and by his careful nursing and skilled attention brought the Pasha through a most serious illness. After Emin Pasha was in a fair way to recovery, Dr. Parke became alarmingly ill, but was able to sail for Suez in January 1890, and arrived in Cairo on the 16th of the same month, after an absence of nearly three years. The volume appropriately finishes with a warm and grateful acknowledgment of his great indebtedness to the several companions of his dangerous journeys ; of one and all of whom he has something pleasant and kind to say. Under trials and troubles of no ordinary nature that had so constantly surrounded them, each did for the other what he could, and long after the painful episodes are forgotten, those of a pleasurable nature remain, stored up in the memory.

No man could wish for greater thanks than those which Mr. Stanley paid his friend the doctor. The unqualified delight with which Mr. Stanley acknowledges that his devotion to duty was as perfect as human nature was capable of, is recorded in the first pages of "Darkest Africa." These praises of his chief were echoed far and wide among Parke's friends and associates at home, so as if it were possible to make up for those many sad and weary days spent by him in the forests and deserts of Africa.

And now, if our task was only to lay before our readers a brief account of what they will find in detail in this

volume, it was at an end ; but it appears to us to be our duty not to leave certain features of this book without criticism. After what we have written, it need not be insisted upon that, as an officer of the Emin Relief Expedition, Dr. Parke did his duty in a splendid manner, and it was as a matter of right that a full measure of praise should be meted out to him therefor. Opinions will differ if it was equally his duty to publish all his rough notes, extending to over 500 pages, as a supplement to Stanley's work ; and still more will opinions differ as to whether he was at all entitled to give English-reading people the contents of his note-book, making no change whatever in them, excepting the necessary ones in the "elementary departments of orthography and syntax." We cordially grant that the history of how this journal was put together demands and should receive many excuses for "its many shortcomings in style and arrangement," but we also think that the author should have hesitated long and taken good advice before he printed all the facts and statements that now must remain on record for ever, and we feel bound to add, many of which should never have been permitted to appear in print in such a work.

Most of the blemishes to which we thus refer could have been easily avoided by the smallest amount of care in editing, indeed the reader of the proofs might have queried the repetitions and contradictions that cannot fail to have met his usually sharp eyes ; others that it might have been considered impertinent for such a one to point out would have been pruned of their offensiveness by the suggestions of any cultured friend. It is difficult without offence to be so plain-spoken as to fully justify these remarks, yet the coarse allusions to certain physiological and pathological phenomena in this volume—not occurring here and there, but scattered very generally through it—must plead our justification. No doubt but in the journal of a medical officer one expects to hear of the diseases to which those under his charge succumbed, and of the various accidents which befell them, and we could pass by the tedious little repetitions of such, as being the result of a day-to-day record ; but no such excuses are possible for such references as those about the Monbuttu pygmy during the preparation for operating on Lieutenant Stairs ; and it may be, perhaps, a matter of taste if particulars such as are given of the condition of the author when ill at Fort Bodo, or of Nelson's sufferings and his own at Ipoté, are in good style, except in a professional treatise.

It is also a subject of profound regret, but not one for censure, that our author seems to have had no knowledge of animal or plant life, nor even, unless when in the company of Emin, any taste for a study of his fellow-man ; we might add that he even exhibits a contempt for such studies, for on more than one occasion he alludes to Emin's natural history investigations as "bug hunting" ; Had it been otherwise, what opportunities there were for destroying that monotony from which he suffered, and what value even some slight knowledge of plants might have been to one who for months had to subsist on vegetable food ; even the knowledge that the pygmy woman possessed was of some service, and she evidently was intelligent enough to have enabled the author to have made out with her aid a short vocabulary of her native language.

The account of the few scraps of the leaves and stems of the plants used by the pygmies to poison their arrow-heads, and of those used as antidotes against these poisons, which had been collected by Parke, is by Mr. E. M. Holme, and is reprinted from the Pharmaceutical Society of Great Britain's Journal. The poisons were prepared from the bark of *Erythrophleum guineense*, Don., from the leaves of probably *Palisota barberi*, Benth., from the bark and stem of the tips of the young shoots of a thorny creeper, possibly belonging to the genus *Combretum*, from the scrapings of the bark of some unknown species of *Strychnos*, and lastly from the seeds of the first-named tree. The antidote to this poison-extract was prepared from the leaves and young bark of three distinct plants, but the material brought back by Dr. Parke was not sufficient to allow of even a guess being made as to two of them, and Prof. Oliver suggests that the third may belong to the genus *Unona*. The illustrations throughout the volume are feeble, if we except the two charming sketches by Mrs. Stanley, and the view of Ruwenzori from a sketch by Stairs; but the rest of the illustrations are of the ordinary make-up type that we do not nowadays expect to find in a serious book of travels.

#### THE AUSTRIAN ECONOMISTS.

*An Introduction to the Theory of Value.* By William Smart. (London: Macmillan and Co., 1891.)

IT has recently become generally known to English students of economics that a school of writers existed in Austria, who strenuously opposed the more extreme views of the German historical school, and devoted their attention to the study and improvement of economic theory. By enabling a larger number of English students to acquaint themselves with the writings of the Austrian economists, Mr. Smart, who is Lecturer on Political Economy in Queen Margaret College, Glasgow, has conferred on them no inconsiderable service. He has already translated the acute and instructive, though difficult and perhaps excessively polemical, treatises of Dr. Böhm Bawerk, on the nature of capital and of interest; and now, in the little volume before us, he introduces us to a theory of value "on the lines of Menger, Wieser, and Böhm Bawerk." The theory, he states in his preface, "is that enunciated by Menger and Jevons, and worked out by Wieser and Böhm Bawerk." It claims to give a more adequate explanation of value than that formerly supplied in economic treatises. It approaches the problem from the side of demand, rather than, like Ricardo and his followers, from that of supply. It declares that "value depends entirely on utility," and that the kind of utility, which is all-important in determining value, is "marginal utility." This conception, which may be found in the pages of Jevons' "Theory," under the title of "final utility," has certainly proved in his hands and in those of his English successors, and his Continental forerunners like Gossen, and contemporaries like Walras, to be a very suggestive and fruitful conception; and its discovery and exposition may be fairly said to have revolutionized one side of the problem of value—which is the central problem, so to

say, of economic study. The conception is more fully elaborated and more scientifically expounded by the distinguished writers who compose the Austrian school, and Mr. Smart traces the outlines of their theory with care and lucidity.

Value, as he shows, may be *subjective*, or relative to the well-being of a person, or *objective*, when it forms a relation of power or capacity between one good and another. The "valuable" and the "useful" are not synonymous terms, but the latter is a larger class including the former, where the useful is so limited as to be the indispensable condition of satisfaction of a want. The scale of value, accordingly, differs from a scale in which wants are classified as "necessaries, comforts, and luxuries"; for the "fundamental and limited wants of life" are "precisely the ones for which Nature makes the most abundant provision." It is the want which is least urgent among the wants satisfied, which measures the value of a good; in other words, it is its "marginal utility." But we must be sure, in estimating this marginal utility, that we know what is really the good we are valuing. A good may be put, perhaps, to different and distinct kinds of uses. The highest use will then have the preference, and the "marginal utility" will only be determined respectively along the distinct subordinate lines of the various uses. Or, again, many, and perhaps most, goods are "complementary," in the sense that several contribute to one satisfaction; and the determination of their separate value becomes in consequence far more complex; and, when we pass from *subjective* to *objective* value, the complications increase in number and variety, although one and the same fundamental law still holds good.

In this, and other similar ways, the Austrian economists have undoubtedly succeeded in giving a more scientific character and wider range to the conception of final or marginal utility. But the question still remains, whether they have fully solved the problem which they have set themselves to determine. They will only allow the older doctrine, which found an explanation of value in "cost of production," to be regarded as strictly subordinate to the principle of "marginal utility." The "causal connection," they maintain, runs from product to cost, and not from cost to product. Consumption is the final object and aim of production, and the side of demand is more important than that of supply. And so it is "marginal utility," which is the "universal and fundamental" law of value, and "cost of production" is a "good secondary law as regards the vast majority of goods produced"; and it is so because goods of the "second" and "higher orders," as they distinguish the goods which are the means and materials of production rather than the articles of immediate consumption, may be employed in the production of more than one kind of goods of the "first order."

But it is doubtful whether the Austrian economists have really grasped, in its fulness, the conception of cost of production which was formed by Ricardo and his followers; and whether, by insisting on the exclusive importance of "marginal utility," they are not giving us a one-sided representation of the facts of the case. In the eagerness with which they have seized and proclaimed the new ideas, it is doubtful whether they have not unduly

neglected the old; and whether a combination of what is sound and true in both may not rather be needed in order to attain the whole truth. It is doubtful whether supply does not react upon demand as much as demand upon supply; whether the consideration of disutility, implied in the conception of cost of production, is not equally important with that of utility, and equally deserving of distinct investigation; whether, in fine, the efforts and exertions of producers to supply wants are not as potent a factor in advancing civilization, and as creative of new wants, as the pressure of wants and desires themselves. The Austrian writers allow so much—though perhaps they here exhibit some lack of distinct statement—to the influence of “cost of production,” that they might, it would seem, go a little further, and place it on an equality with the principle of marginal utility. They would then, perhaps, recognize what Prof. Marshall, in his broader, and, as it appears to us, more philosophic, exposition of value, calls the fundamental symmetry of the laws of the forces working on both sides, which is exhibited in the analogy between “marginal utility” and “marginal cost of production,” and a law of “diminishing returns” and one of “decreasing utility.” They would, in short, without sacrificing altogether the vast amount of trouble bestowed by Ricardo and his followers on one side of the problem, assign a proper, and not an exclusive, emphasis to the side which they had themselves done so much to elucidate. For these reasons we consider Mr. Smart’s modest conclusion—that “the last word on value has not been said by the Austrian school”—to be as sound and as pertinent, as his exposition of their views is clear, pointed, and suggestive.

OUR BOOK SHELF.

*Across Tibet.* By Gabriel Bonvalot. Translated by C. B. Pitman. Two Vols. (London: Cassell and Co., 1891.)

AFTER the return of M. Bonvalot and Prince Henry of Orleans from the East, so much was said of their journey that we need not now repeat any of the details of M. Bonvalot’s narrative. It may suffice for us to commend the book very cordially to the attention of readers who like to wander in imagination with travellers in remote parts of the world. M. Bonvalot, as his translator says, has those qualities of courage, self-command, tenacity, knowledge of human character, and good humour, which go to make up the successful traveller; and he writes of his achievements so simply and naturally that there is nothing to interfere with the reader’s full enjoyment of his story. The travellers, as everyone interested in geographical exploration will remember, started from the frontiers of Siberia, and in the course of the journey which brought them to Tonquin passed right through Tibet. Their route lay to some extent over ground which no European had ever before traversed, and this is, of course, the portion of his subject on which M. Bonvalot writes most carefully and effectively. The work has been translated in a clear and pleasant style, and it is enriched with many interesting illustrations.

*Light.* By Sir H. Trueman Wood. “Whittaker’s Library of Popular Science.” (London: Whittaker and Co., 1891.)

WE have here a popular and interesting account of many of the facts relating to the nature and properties of light. The subject is treated in a way that will induce many readers to glance through its pages, even if they do not

more carefully peruse it; while many a more advanced student will read the chapters on double refraction and polarization, lenses, and interference and refraction. Of other points touched on, we may mention spectrum analysis, optical instruments, chemical effects of light, fluorescence and phosphorescence—all of which are delightfully treated by the author.

In the appendix will be found a list of the more elementary and popular works on the subject, which should prove useful to those who wish to extend their knowledge.

LETTERS TO THE EDITOR.

[The Editor does not hold himself responsible for opinions expressed by his correspondents. Neither can he undertake to return, or to correspond with the writers of, rejected manuscripts intended for this or any other part of NATURE. No notice is taken of anonymous communications.]

Opportunity for a Naturalist.

WILL you allow me to say that the letter which you kindly inserted under this head in your issue of December 24, 1891 (p. 174), has brought me many replies? After considering them, I have made arrangements with Mr. O. V. Aplin (member of the British Ornithologists’ Union, and author of “The Birds of Oxfordshire”) to proceed to Uruguay in August next. Mr. Aplin will reside for six months on an *estancia* in the province of Minas, and devote himself primarily to birds, but will also collect insects and plants. P. L. SCLATER.  
3 Hanover Square, W.

Dwarfs and Dwarf Worship.

IN the slow course of post in this Protectorate I have just received copies of the *Times* of September 3 containing Mr. R. G. Halliburton’s paper on “Dwarf Races and Dwarf Worship,” and of September 14 and 22, containing subsequent correspondence on the same subject. Having crossed the Atlas Mountains at several different points, and approached the district which is indicated by Mr. Halliburton as the original home and hidden sanctuary of his diminutive and venerated people, I have read his paper with much interest and may perhaps be permitted to criticize his conclusions. My chief during my expedition to Morocco, that distinguished traveller Mr. Joseph Thomson, is, I believe, at present in Katanga, and therefore more inaccessible than I am; but when he is able to speak on the subject, his judgment on the case which Mr. Halliburton has very elaborately set up will not, I am confident, be different from mine.

Mr. Halliburton begins with a statement that is at once startling and decisive. The information he has collected puts it, he says, beyond question that there exists in the Atlas Mountains, only a few hundred miles from the Mediterranean, a race of dwarfs only 4 feet high, who are regarded with superstitious reverence or are actually worshipped, and whose existence has been kept a profound secret for 3000 years. Such an emphatic assertion ought to rest on clear and irrefragable evidence; and I read Mr. Halliburton’s paper in constant expectation of the proofs of his remarkable discovery, but reached the end of it without coming on a shred of testimony in support of his contention, of the slightest value to anyone acquainted with Morocco and the Moors. The paper is highly discursive, and abounds in what seem to me far-fetched and irrelevant speculations, on the connection between ancient Moorish poems and Greek mythology, on the derivation of the Phœnician deities, and on the meaning of Moorish habits and customs; but the only evidence, confirmatory of its theses, adduced in it and in Mr. Halliburton’s subsequent letters, amounts to this: that six Europeans have seen dwarfs in Morocco; that an indefinite number of natives have romanced about dwarfs in their usual way; that there are in Morocco artificial caves—presumably dwellings—of such small size as to suggest that they must have had very short inhabitants; and that there have come down to us from antiquity traditions as to Troglodytes who dwelt in the Atlas Mountains.

Mr. Halliburton’s European witnesses are unimpeachable; and had my friend Mr. Hunot, whose knowledge of the country is extensive and accurate, distinctly said that there is a race of dwarfs in Morocco, I should not have ventured to con-

tradict him. But all that Mr. Hunot says, in the long paragraph quoted from his letter, is that he recollects an adult dwarf of about the height of a boy of ten or eleven years of age who lived and died in Mogador. All that Captain Rolleston says is that he saw in Tangiers a dwarf of about thirty-five or forty years of age 3 to 4 feet in height, and of an unusually light complexion. All that Mr. Carleton says is that he has seen a dwarf at Alcazar. All that Sir John Drummond Hay says is that he hunted up at Tangiers some Sus and Dra people who had seen dwarfs. All that Miss Day says is that she had done the same at Telmen. All that Mr. Harris says, of his own knowledge, is that he has seen two dwarfs—one at Fez, about 4 feet 2 inches in height, and of a light brown colour; and the other, about whom no particulars are given, somewhere in the country. All that Miss Herdman, whom I had the pleasure of meeting at Fez, says is that she has never seen a dwarf in Morocco, but that she has heard of one, and has drawn out tales about a tribe of dwarfs from her native servants. All that Mr. Halliburton himself says to the point is that he has seen and measured a very timid and obliging dwarf of about thirty years of age, 4 feet 6 inches in height, and of a peculiar reddish complexion, in Tangiers.

Let me add to Mr. Halliburton's list of European witnesses. I have myself seen two dwarfs in Morocco—one in Fez, and the other in some northern town (I cannot for the moment recollect which, and have of course no papers to refer to). The first of these might perhaps have passed as a true dwarf—a man of small size, but well proportioned, like Tom Thumb; but the other was certainly a disease-dwarf, with a large unshapely head and trunk, and little bowed legs, like Canny Elshie, or the Wise Wight o' Mucklestane Moor. Rickets are not unknown in Morocco. I have no doubt that that malady is common in certain districts periodically visited by famine or devastated by war, and in which infant feeding is not conducted on scientific principles; and the probability is that men and women of stunted and distorted growth are more numerous in proportion to population in Morocco than they are in England. The wonder is to me that the number of instances of the occurrence of dwarfs in Morocco, which Mr. Halliburton in his long-continued researches has been able to establish, is so exceedingly small; and that one dwarf, for example he of Fez, has, like a stage army, to do duty several times over. But had he succeeded in identifying ten times the number of dwarfs that he has actually traced out, he would only have proved that dwarfs exist in Morocco as in all other countries, and would not have advanced a step towards proving his proposition that there is a tribe of dwarfs in the Atlas. I know a little Scotch town in which there are three dwarfs; but it would be scarcely legitimate to infer from that fact that there is a concealed clan of MacManikins in the Grampians. That the dwarfish condition in the dwarfs described by Mr. Halliburton was an accidental variation, and not a racial characteristic, is rendered more than probable by the fact that two of them—the only two who are reported to have had families—had offspring of normal stature.

The native reports about dwarfs and dwarf tribes, which Mr. Halliburton sets forth in much detail, are obvious fictions—of the kind which the professional story-teller pours forth copiously every day in the Soko in scores of Moorish towns and villages, only adapted, of course, to the requirements of an eager English listener. The names of the reporters are not given, nor are the opportunities they possessed of obtaining the information they convey explained; while some of the practices they attribute to the dwarfs—such as finding of treasure by writing on wood, and the feeding of horses on dates and camels' milk with the view of rendering them swift of pace—I have heard ascribed to tribes in the Atlas that are certainly not composed of dwarfs.

Morocco is the hot-bed of fable, and infested by the cock-and-bull, and I can picture to myself the grave delight with which the natives questioned by Mr. Halliburton would stimulate his curiosity and then satisfy it. Mr. Halliburton emphasizes the fact that he is a Q.C., and accustomed to cross-examination; but British perjury and Moorish mendacity have little in common, and are to be fathomed by entirely different methods. The way in which he measured the Tangiers dwarf, Jackin (he actually took 2 inches off his height because a native who was present told him that Jackin had raised his heels to that extent while being measured), casts some doubt on his powers of observation; while the extracts from his diary show that no process of sifting has been carried out, but that everything favourable to his theory has been thankfully received. I

would undertake to collect in Morocco in a month's time native testimony in support of the existence of a tribe of giants in the Atlas, or of a tribe of men with six digits on each hand, quite as specious and convincing as that which Mr. Halliburton has accumulated in favour of the existence of a tribe of dwarfs. Even if the natives interrogated by Mr. Halliburton had no wish to deceive or to please him, much would depend on the intelligence and honesty of his interpreter, and on the exact terms employed. Only those who have tried can realize how difficult it is to get precise information on any subject out of natives of Morocco.

If the caves in Morocco are to be regarded as at one time the dwellings of dwarfs, then it is clear that dwarfs must at one time have been in complete possession of the country, for such caves are to be found all over it. The most remarkable of them which I have visited at Tassimat, about two days' journey from Demnat—caves which Europeans had never before explored, and which were excavated in a rock by the side of a waterfall—were in many instances too small even for the accommodation of dwarfs; and as they yielded to our digging fragments of bone and of pottery, it seemed probable that they had been places of sepulture and not of habitation. Such caves have also undoubtedly been used sometimes for the storage of grain, like the underground metamors; and the invariable answer returned to our inquiries about their origin was that they had been made by the *Romi*, or Christians. Never on any occasion did I hear them ascribed to dwarfs.

The classical tradition that there were dwarfs in the Atlas is unworthy of serious consideration in the absence of any observation suggesting that it had other than an imaginative foundation. "Nearly all the myths of Greece," says Mr. Halliburton, "are laid in Mount Atlas," and monsters more extraordinary than dwarfs must have dwelt there if these myths are to be received as of historical authority.

I have tried to prove that the evidence given in favour of the existence of a tribe of dwarfs in the Atlas is utterly trivial and untrustworthy; and I shall now endeavour to show that the evidence that can be called to discredit that hypothesis is cogent and convincing. The dwarfs are described by Mr. Halliburton as brave, active, agile, swift-footed, as possessing a vigorous breed of ponies, as experts in the pursuit of the ostrich, and as trading in the Sahara and at Tassamat. Is it to be believed that being all this, and being very numerous—there are, Mr. Halliburton says, about 1500 of them in Ait Messad, about 1500 at Akdeed, about 1000 at Ait Messal, about 500 at Ait Bensid, and about 400 in three Akka villages—is it to be believed, I ask, that these swarming and enterprising dwarfs would have allowed themselves to be bottled up in a cleft in the Atlas Mountains, so that only half-a-dozen specimens of them have found their way to the great towns to the north of the Atlas, where are to be found numerous representatives of all the other Atlas tribes? Is it to be believed again, that the existence of such a peculiar and notorious tribe, known, Mr. Halliburton tells us, to all Moors, should have been concealed from all the inquisitive travellers who have penetrated into the interior of Morocco, to be revealed to Mr. Halliburton standing at its outer gateway? Leo Africanus, whose account of Morocco is marvellously minute and accurate, and who enumerates its tribes, has not a word to say about dwarfs. De Foucaud, who visited Akka, is equally silent about them; and so is Rohlfis, who explored the valley of the Dra. Not one traveller in Morocco has ever heard even a rumour or dark hint relating to them.

Thomson and I spent some months in the Atlas in constant communication with natives of every class, and in all the strange legends, histories, and adventures narrated to us by the camp brazier, in the *fondak* or the *kasba*, there was never a distant reference to a Moorish Liliput; and be it remembered our servants knew that we had a keen eye and ear for curios, human and inhuman. In all our wanderings in the Atlas we never met a dwarf, and indeed, at a great gathering of people at which we were present, at the feast of Aid el Assir at Glawa we were much struck by the height of the men. Mr. Aissa, who is quoted by Mr. Halliburton as having seen one of the tribe of dwarfs east of Demnat, was our interpreter for three months, and conversed with us with the utmost freedom on all conceivable subjects, and he never adverted to this dwarf story. I have had several long talks with Mr. Hunot, whom Mr. Halliburton also quotes—conversations covering a wide range of topics, amongst them the origin of the caves already alluded to—and he certainly at that time had no belief that they had ever



been tenanted by dwarfs, or that there was any dwarf tribe in the country. It is especially noteworthy that Du Bekr, the confidential agent of the British Government at the Court of Morocco, replied to Sir William Kirby Green that no Moor had ever heard of a race of dwarfs in the country. Sir William knew how to interrogate a Moor, and as he accepted Du Bekr's statement, I have no doubt that Du Bekr was speaking the truth.

Until the existence of a race of dwarfs in the Atlas Mountains is proved, it is idle to indulge in guesses at the reasons which have led to the fact of its existence being jealously kept secret; so I shall not follow Mr. Halliburton in the argument by which he seeks to show that the race has been regarded with superstitious reverence, and so kept apart. In all countries, at all times, I believe dwarfs and deformed persons have been looked at askance by the ignorant and superstitious. In Scotland they were regarded as fairies of a brutal and malignant type; and in Morocco I have no doubt they have been credited with the possession of the evil eye and of other pernicious powers. But to maintain that a tribe of them has ever been held sacred and worshipped in the heart of a Mahometan country that is fiercely fanatical is to do violence to our fundamental conceptions of Islam.

Mr. Halliburton's statements about the origin and habits of his supposed tribe of dwarfs are not more worthy of discussion than his theory of the causes which have led to their concealment. They are derived from native sources of the most tainted description, and are either pure inventions, or concoctions of truth and falsehood. We are told that a tribe of acrobats—the Ait Sidi Hamed O Moussa (the tribe of the son of Moses)—is an offshoot of the Aglimien dwarfs, living between the Dra and Akka; that they are a rather small race with a light red complexion; and that dwarfs perform with them in Southern Morocco, but avoid the coast towns where Europeans are; and that they are smiths and tinkers. Now, the paragraph setting forth these statements contains just as much error and confusion as it is possible to cram into so many words. The Sidi Hamed O Moussa are not a tribe at all, but the followers of a saint whose Kuba is not far from Taradant. Their troupes are made up of men drawn from various parts of the country; and it would be as correct to regard the Jesuits as a tribe, and describe their ethnic characteristics, as it is to assign distinctive features to the Sidi Hamed O Moussa. Then, as a matter of fact, they are not unusually small men, they are not smiths and tinkers, and they never have dwarfs performing with them either in town or country. I saw several troupes of them in Southern Morocco, and can testify that they are of average size and of the usual Moorish tint; that they follow a more profitable trade than that of tinkering; and that they have no dwarfs among them.

Mr. Halliburton strongly advises European travellers and tourists to abstain from any attempt to enter the districts of Morocco inhabited by the dwarfish race, as they would inevitably, while doing so, be murdered or robbed, whether Moslems, Jews, or Christians. The advice is judicious, for open-mouthed travellers of any persuasion, in quest of dwarfs, are not unlikely to be murdered or robbed in any part of Morocco except in those coast towns to which Mr. Halliburton has apparently confined his own wanderings in the country. European travellers of another sort, however—resolute, incredulous men, explorers, and pioneers of trade and commerce—will certainly before long penetrate all those regions where the dwarfish race has been located by Mr. Halliburton. Remembering what I have heard on good authority of the resources of some of those regions, and the indications I have seen of the mineral wealth of that region to the south of the Atlas where Mr. Halliburton has placed the original home of his dwarfs, I feel disposed to exclaim, like the old sailor in Millais's famous picture "The North-West Passage": "It can be done, and England ought to do it!" When, however, these regions are opened up, I feel sure that, amongst much that is wonderful in them, there will be found no tribe of dwarfs hemmed in by religious sentiment.

To those interested in the generation and growth of myths in modern times, and under Congress culture, Mr. Halliburton's dwarf-story cannot but afford an instructive study.

HAROLD CRICHTON-BROWNE.

Macloustie Camp, Bechuanaland, November 15, 1891.

### Sun-spots and Air-temperature.

It is now widely believed by meteorologists that a certain relation exists between the solar sun-spot cycle and the air-tem-

perature of the earth, such that to a minimum of sun-spots corresponds, approximately, a maximum of air-temperature, and *vice versa*. From the comprehensive researches of Dr. Köppen on the subject some time ago, it appeared that this relation is most clearly proved in the case of the tropics, the evidence becoming less as we go north and south. Mr. Blanford showed recently in NATURE (vol. xliii. p. 583) that the evidence in the case of India has of late years greatly increased in force.

In a climate so variable as ours it is not, perhaps, to be expected that the existence of such a relation should be very patent and obvious. And there may be some legitimate doubt whether its existence has yet been demonstrated. It is in the hope of possibly advancing the matter somewhat that the following facts are presented.

If we decide to take for our consideration a part of the year instead of the whole, we shall naturally select the hotter part; the part in which the solar action is greatest (just as we might expect to find, and do find, better proof of the relation in tropical than in cold countries). I select the four months June to September. The data used are, Mr. Belleville's observations of Greenwich mean temperature from 1812-1855, which are, it should be noted, reduced to sea-level (see Quat., Journ. of the R. Met. Soc., January 1888, p. 27), and thereafter the ordinary Greenwich figures. The average difference (about half a degree) does not materially affect the purpose here set.

Taking the mean temperature of those four months, and smoothing the values by means of five-year averages, we get the second, thick line curve in the upper diagram herewith. The dotted line curve is that of sun-spots, inverted (*i.e.* minima above and maxima below). The vertical scales for these are both to the left.

There is evidently a correspondence between these curves as far as about 1870; maxima of temperature lagging a little, as a rule, behind minima of sun-spots, and minima of temperature behind maxima of sunspots. Since about 1870, the correspondence appears to fail. We look for a temperature-maximum about 1879, and we do not find it.

A consideration of the rainfall here seems instructive. The smoothed curve of rainfall in those four months (third in the diagram; Chiswick to 1869, thereafter Greenwich) is, in the main, roughly inverse to the temperature-curve, as we might expect. Yet it is difficult to trace a very definite relation between it and the sun-spot curve. Thus, consider the three most salient "crests" in it. The first (in height as well as time), in 1829, is close before a sunspot maximum, 1830. The second (least salient of the three), in 1861, is close after a sunspot maximum, 1860. The third, in 1879 and 1880, is close after a sunspot minimum, 1878. These rainfall variations, indeed, seem to be under some different law, and it will be observed that the last crest comes (the first example in the whole period) just about where we should expect, from previous experience, to find a temperature-maximum. The regular variation of this curve in one direction for several years is a noteworthy feature recently (in 1880 to 1885, and again in 1885 to 1889). Is the curve now near a maximum which will be found to coincide with a further obliteration of the normal correspondence between sun-spots and temperature?

We have thus far considered the group of four months, and they seem to me to support the view under consideration. May we further look for the relation in individual months?

Suppose we see reason in doing so, and make a selection. The most likely month would perhaps seem to be July, as having the maximum temperature; or June, as that month in which the sun is highest.

On examining the smoothed curves of mean temperature for each of those four months, we find that June and September show a large amount of the correspondence with the sun-spot curve, while the two others do not show much correspondence. These two curves (June and September) are given in the lower diagram, superposed; the two vertical scales being at the left. June, it will be noticed, presents a wave crest fairly corresponding with each of the six, or seven, sun-spot minima. In the case of September there is a pronounced failure at the sun-spot minimum in 1878.

As a possibly good reason why September might show the relation, while July and August do not (or not so well), I would suggest the fact that September is the month with least cloud. Between May and September, cloud increases to a small secondary maximum in July.

The absence of a maximum of temperature in September

corresponding to the sun-spot minimum in 1878 may, perhaps, be connected, as in the case of the four months' curve, with the rainfall. A smoothed curve of humidity for September rises, I find, to a high maximum in 1880. The June humidity curve does the same, and if it be therefore asked, why we should not have a similar failure in that month's curve, I would invite attention to the fact that the rise to the maximum in the humidity curve for June is a rapid one from the absolute minimum (reckoning from 1858) in 1876; while the rise in September is

predicted time, given in Marth's ephemeris (*Monthly Notices*, March 1891), is 5h. 32'6m., so that the spot was 10'4m. late, and this means a decided slackening in its motion of rotation during the present apparition. On August 7, 1891, I saw the spot pass the central meridian at 11h. 32m., or only 2'3m. after the time indicated in Marth's ephemeris. In the interval of 5 months, during which 362 rotations were performed, the mean period has been 9h. 55m. 42s., which is nearly 1 second greater than the rotation period of this marking as observed here during

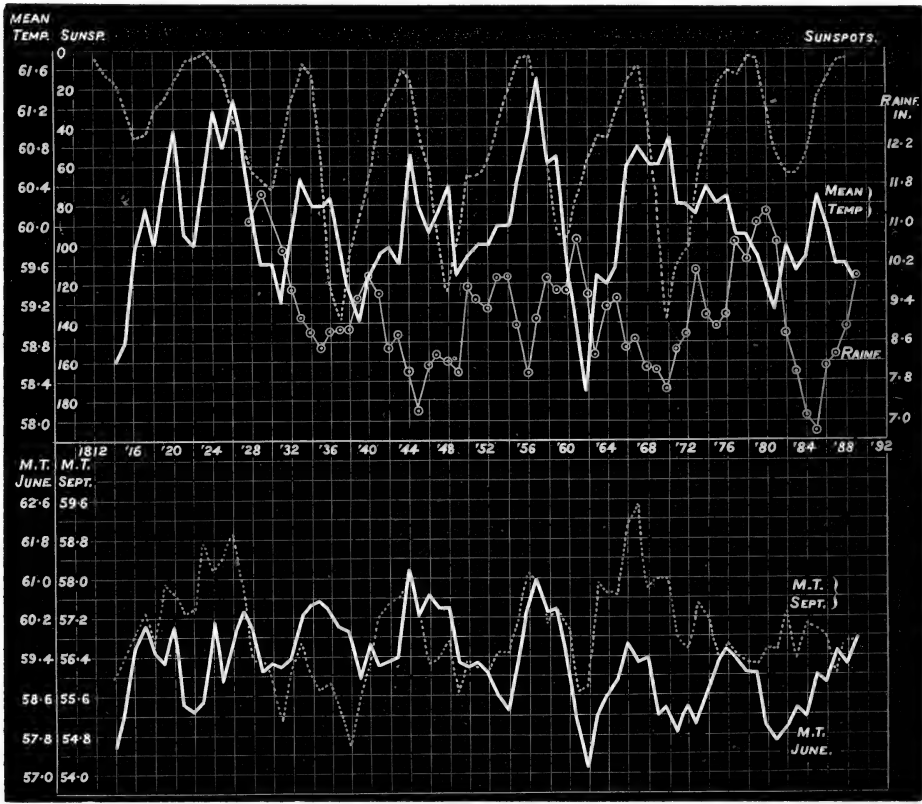

more gradual from an absolute minimum in 1870. Thus, the wave in June corresponding to the sun-spot minimum in 1878 might be regarded as but partially formed, the growing humidity, or rainfall, presenting its normal culmination.

However this may be (and I do not press these suggestions), it has seemed to me desirable to submit the coincidences presented in the diagram (which I have difficulty in thinking wholly fortuitous, and which are quite in harmony with the general view enunciated by Köppen) to minds more competent to estimate their nature rightly.

A. B. M.

**The Red Spot on Jupiter.**

ON January 4 last, at 5h. 43m., the red spot on Jupiter was estimated to be on the central meridian of the planet. The

any previous opposition. In 1890 I determined the period as 9h. 55m. 40'2s., which differed very slightly from that derived from my observations in 1887, 1888, and 1889. It now appears, however, that a marked retardation has occurred, and it remains to be seen whether this will be maintained until the close of the apparition.

The spot continues to be a fairly conspicuous object, and it retains its oval outlines, but it is not nearly so dark and definite as it was in the years from 1878 to 1881.

Bristol, January 10. W. F. DENNING.

**The Implications of Science.**

DR. MIVART complains that in my last letter I merely affirmed without arguing. This is in a measure true as, to

economize your space, I only gave the skeleton of the argument, but I hoped I had said enough to indicate at least the general outline of my logical views. But as this seems not to have been quite the case, may I now explain myself a little more fully?

I may remove a slight misunderstanding at once. I said our knowledge of our own continuous existence *in the present* is to each of us a necessary truth. Dr. Mivart reads this as if I had written "our continued existence in the future"! That we cannot be annihilated while we know that we are existing is, as I shall presently show, *not* a mere consequence of the law of contradiction. If this law is of any use at all in proving the conclusion, it would certainly be useless without a second premiss, viz. that we are existing; and this latter is the premiss which is a necessary truth.

I suppose everyone will acknowledge that a definition is essentially an arbitrary assertion, and that therefore a definition can by itself give no real information. But a well-understood term does not consist of a definition alone. Its definition may be laid down, as a list of items of connotation (or denotation), and the other part of its meaning, which may be called its import, that is its denotation (or connotation) must be discovered by experience; and the knowledge so acquired is real, not only verbal, knowledge. Now it is possible from a number of definitions *alone* to deduce a series of propositions. These, like the definitions from which they were deduced, give by themselves only verbal information—they are all truisms—and before they can be made of any practical use, certain real assertions, assigning real import to the terms, and so expressing real knowledge, must be added to the premisses. Thus, if we wish to determine whether any given proposition is a truism, or conveys real information, we have only to examine the definitions of its terms. If these are found to be inconsistent with each other, the proposition is a contradiction in terms, and must be rejected. If the definitions are not inconsistent, but are independent of each other, the proposition can only be intended to assert the identity of the import of its terms—it therefore conveys real information, which may either be true or false. Lastly, if the definitions can be shown to be dependent on each other, the proposition is equally true whatever import its terms may have, or even if they have no conceivable import at all. It is a truism. If, however, by the aid of other real propositions any real import can be given to its terms, it may have objective, or subjective, applications; but the objectivity or subjectivity is introduced by those other propositions, and is not a property of the original truism.

Take, for example, the proposition, "Everything must either 'be' or 'not be'"; or the proposition, "Twice two is four." The truth of either of these propositions depends solely on the definitions of its terms, as I pointed out in my last letter, and this is why I cannot regard them as objective truisms. Of course I do not doubt that if I had lost an eye I should not remain in the same condition as I was before. But, although "no man out of Bedlam would suppose a statement of a general law would inform us about a concrete thing," this is precisely what Dr. Mivart does if he regards the above proposition as dependent solely on the law of contradiction. Does he not see that he added the objective element to that law in the phrase, "if he had lost an eye"? "Much virtue in If." The status of the proposition, "Two straight lines cannot inclose a space," similarly depends on the definitions of its terms; but, as I pointed out in my last letter, these terms may be defined in two different ways—either by dependent definitions, so making the proposition a truism, or independently so as to make it a real assertion, in which case it might conceivably be false. Dr. Mivart apparently takes the former set of definitions, and then implies that I deduced the latter result from them, which, if he reads my letter again, he will find not to have been the case.

In reply to Miss Jones, I may point out—

(1) It most certainly is merely a verbal convention when Miss Jones says, "A and a' are not applicable to the same thing." She had herself just before laid down the convention in question, in the phrase, "If A signifies the negation of a (whatever A may stand for)."

I do not know why Miss Jones should imagine that I think that "assertions (or denials) of the 'existence' of particular objects are the only real propositions," but perhaps she will understand my view better when she has read this letter.

(2) I certainly hold that "inductions have no logical justification whatever," if by "logic" is to be understood formal, or,

as I prefer to call it, symbolic, reasoning. The essence of induction, in my opinion, is the assumption (at first arbitrarily) of an hypothesis to account for observed facts—that is, ultimately, of directly apprehended sensations. The full significance of the hypothesis is elucidated by symbolic reasoning, and the *enumeratio simplex* is applied to the results of this reasoning, and does not, therefore, appear quite in the simple form exhibited by Miss Jones. But it remains equally true that no induction can ever lead to a necessary truth.

(3) Miss Jones's view of mathematical reasoning is exactly that which I wish to combat. We do not, in mathematics, conclude a universal proposition from a single concrete instance. A mathematical formula does not imply the existence of any instance whatever of its application, any more than a definition implies the reality of the thing defined. The formula is deduced from what may logically be regarded as definitions, and one or any number of applications may indeed be found afterwards, but only by the aid of additional real premisses. It is difficult to exemplify this in the case of geometry, because the accepted geometrical methods are so very imperfect, and geometrical conclusions are not always deduced from definitions alone. As I implied in my former letter, some of them are founded on induction. But it must be evident that the truth of, say, De Moivre's Theorem, does not depend on our having seen that it was true in any one instance.

(4) If Miss Jones reads her own paragraph (4) again carefully, I think she will see that it is not I who have contradicted myself. I showed that if the definitions of the terms of a certain proposition were altered, the proposition might no longer be true, and that if they were not altered it would always be true. *Argal*, the truth depends on the definitions, and on nothing else.

I did not maintain that it could ever be to anyone a necessary truth that he was writing with a lead-pencil. That would be an objective proposition, such as I was careful to insist could only be proved by induction. It might, however, be a necessary truth to anyone that he *thought* he was writing with a lead-pencil. As to mathematical truths, so far from believing that "in as far as 'real' they are obtained by induction," I expressed my opinion that they are not "real" at all, but all truisms. Any reality in their applications must be added from outside, by real assertions which are not "mathematical." I object to calling truisms "necessary," not because they are possibly false, but because their truth is only arbitrary. On the other hand, when I call "the apprehension of a present fact" a necessary truth, I mean something more than that it is certain—namely, that its contradictory is unthinkable.

EDWARD T. DIXON.

Trinity College, Cambridge, January 8.

#### FRESH EVIDENCE CONCERNING THE DISTRIBUTION OF ARCTIC PLANTS DURING THE GLACIAL EPOCH.

LAST summer (1891) I spent some weeks in Western Russia and Northern Germany, in order to ascertain whether the glacial fresh-water deposits of those countries contained any remains of the vegetation which lived there immediately after the inland ice had melted away. The results of my journey being favourable, I have thought it desirable to communicate them to the readers of NATURE; but before doing so it might be convenient to give a brief summary of previous investigations on the same subject.

The first discovery of fossil Arctic plants was made in England by Mr. W. Pengelly, who found in 1860, at Bovey Tracey, in Devonshire, leaves of the dwarf birch (*Betula nana*), together with leaves of some willows, as *Salix myrtilloides*, *S. cinerea*, *S. sp. indet.* The leaves were identified and described by the late Prof. Heer,<sup>1</sup> who pronounced the opinion that the presence of *Betula nana* was conclusive evidence of "a colder climate than Devonshire has at the present day." The significance of this discovery was, however, but little appreciated until the researches mentioned below again

<sup>1</sup> Philosophical Transactions, 1862, p. 1039. In this paper Heer mentions *Salix repens* (?), but this determination was subsequently altered to *S. myrtilloides*.

called attention to the nature of the vegetation which grew round the margin of the great northern inland ice, on the soil which was left bare when it melted away.

During my first visit to Spitzbergen, in 1870, it occurred to my mind that—supposing the glacial theory were true—the remains of those Arctic plants which, in all probability, formerly existed in the area once covered by the great Scandinavian inland ice, would have been buried in the glacial fresh-water deposits, just in the same manner as the leaves of *Salix polaris*, *Dryas octopetala*, *Polygonum viviparum*, &c., are at the present day carried into the small lakes of Spitzbergen,

found the Arctic fossil flora underneath some peat-mosses in the immediate vicinity of Copenhagen. In 1872 I discovered leaves of *Betula nana* in a peat-moss near Oertzenhof, in Mecklenburg, and at Kolbermoor, in Southern Bavaria. In Switzerland I also found an Arctic-Alpine flora in a fresh-water deposit at Schwerzenbach, on the low ground between Zürich and Bodensee. The flora was rich in such species as *Betula nana*, *Salix reticulata*, *S. polaris*, *S. retusa*, *S. myrtilloides*, *Arctostaphylos uvu-ursi*, *Polygonum viviparum*, *Azalea procumbens*, &c.

From Switzerland I went to England, and first visited Bovey Tracey (17),<sup>1</sup> where I re-found *Betula nana* in the

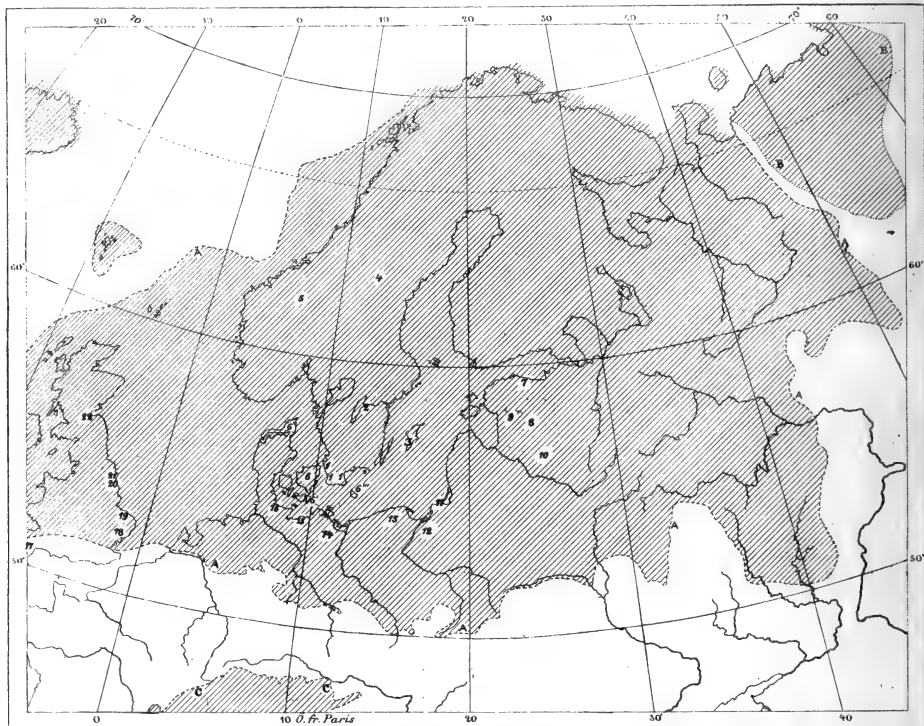

SKETCH MAP SHOWING THE LOCALITIES WHERE ARCTIC PLANT-FOSSILS HAVE BEEN FOUND WITHIN THE AREA ONCE COVERED BY THE GREAT NORTHERN ICE-SHEET.

a, margin of the great northern inland ice at the climax of glaciation; b, margin of the Uralo-Timan glacier (according to Nikitin); c, margin of the glaciers of the Alps.

(1) Several localities (more than thirty) in Scania; (2) Rangilstorp, near Vadstena; (3) Fröjel, in the isle of Gotland; (4) several localities in Jemtland; (5) Leine, in Norway; (6) several localities in Seeland; (6') Möen; (6'') Northern Jutland; (6''') Bornholm; (7) Kunda, in Estonia; (8) Samhof and Kinzli, in Livonia; (9) Pingo and Wieratz in Livonia; (10) two localities at Rjeshiza, Government of Vitebsk; (11) Kuhrische Nehrung; (12) Schroop, in Western Prussia; (13) Krampkewitz, in Pomerania; (14) Neetzka and Oertzenhof, in Mecklenburg; (15) Nantrow, in Mecklenburg; (16) Projensdorf, north of Kiel; (17) Bovey Tracey, in Devonshire; (18) Hoxne, in Suffolk; (19) several localities at and near Cromer, Norfolk; (20) Holmpton, Yorkshire; (21) Brndlington, Yorkshire; (22) localities near Edinburgh.

and buried at their bottoms. On my return from that expedition, I at once examined some glacial fresh-water deposits at Alnarp, in Scania, and was glad to find in them the leaves of *Salix polaris*, *S. herbacea*, *S. reticulata*, *Dryas octopetala*, *Betula nana*, &c.; thus proving that a true Arctic flora had once lived in the southernmost part of Sweden. The next year, after having discovered the same flora in a great many other localities of the same province, I was invited by Prof. Japetus Steenstrup to extend my researches into Denmark; and our joint investigations were soon crowned with success, for we

original locality, and also in another little basin close by, together with leaves of *Arctostaphylos uvu-ursi* and *Betula alba*. Then I went to the coast of Norfolk, where I was so fortunate as to find *Salix polaris* and *Hymnum turgescens* in the pre-glacial deposits between the boulder-clay and the forest-bed in the vicinity of Cromer (19). This plant-bearing bed has since then been noticed by Mr. Clement Reid, of the Geological Survey, who has named it the "Arctic fresh-water bed," and he has traced

<sup>1</sup> The figures within parentheses refer to those on the accompanying sketch map.

it in some other places on the coast of Norfolk. Besides *Salix polaris*, Mr. Reid has also found in it leaves of *Betula nana* and seeds of some other plants. At Hoxne, in Suffolk (18), Messrs. Reid and Ridley have discovered *Salix polaris*, *S. myrsinites*, and *Betula nana*, together with many other species in a glacial fresh-water deposit of a precisely similar character to those in Southern Sweden. Again, in 1879, I found leaves of *Betula nana* in a peat-moss at Bridlington (21), and the same plant has been found by Mr. Reid at Holmpton (20). According to a statement of Mr. Reid, *Salix herbacea* was found some years ago by Mr. Bennie in an inter-glacial deposit at Hailes, about three miles from Edinburgh. Finally, during this present year (1891), Mr. Reid has himself discovered a rich Arctic flora, yielding *Salix polaris*, *S. herbacea*, *S. reticulata*, *Azalea procumbens*, and *Betula nana*, in lacustrine deposits immediately above the boulder-clay near Edinburgh (22).<sup>1</sup>

Returning to Sweden, a great many new localities yielding Arctic plants have also been found in Scania since 1871, partly by myself, partly by Dr. Gunnar Andersson and others, so that the number of localities in Scania (1) now exceeds thirty. In Ostrogothia, leaves of *Betula nana* and *Dryas octopetala*, &c., were found in 1886 in a calcareous tufa near Vadstena at Lake Vetter (2); and in the isle of Gotland (3), Mr. R. Sernander, in 1890, discovered leaves of the same species in a fresh-water deposit overlain by the curious gravel-bed containing *Ancylus*. In Jemtland, Mr. A. F. Carlson, in 1885 and 1886, discovered leaves of *Dryas* and *Salix reticulata* in calcareous tufa in several localities (4) far removed from the regions where these species now exist. In Norway nothing whatever was known of the ancient Arctic flora until last summer (1891), when, according to Prof. A. Blytt, leaves of *Dryas octopetala* were found in calcareous tufa at Leine (5). In Denmark the continued researches of Prof. Steenstrup have added many new localities (6) to the original ones mentioned above, not only in Seeland, but also (from a private communication made to the author) on the isle of Møen (6'), in Northern Jutland (6''), and on Bornholm (6'''). Turning to Switzerland, Prof. C. Schröter, of Zürich, has discovered three new localities for the glacial flora, and in 1880 I myself found leaves of *Salix herbacea*, *Dryas octopetala*, and *Betula nana* in a fresh-water deposit near Hedingen (Canton Zürich), and leaves of the last-mentioned species underneath a peat-moss at Wauwil (Canton Luzern), and in peat at Le Chaux de Fonds.

It ought also to be mentioned that Prof. M. Staub, of Buda-Pest, has lately described a fossil glacial flora from the Southern Carpathians, which, besides seeds of *Pinus Pumilio* and *Pinus Cembra*, also contains leaves of *Dryas octopetala*, *Betula nana*, and *Salix myrtilloides*, together with fruits of *Tofeldia borealis*, thus proving the existence of a somewhat colder climate than the present one.

In 1880, I discovered a locality at Neetzka, in Mecklenburg, not far distant from Oertzenhof where I had found *Betula nana* in 1872. The new locality (14) yielded *Dryas octopetala*, *Salix reticulata*, *Betula nana*, *B. odorata*, and *B. verrucosa*, together with leaves of *Myriophyllum*, some other *Salices* and mosses, such as *Hypnum scorpioides* and *H. Juitans*. According to the manner in which the samples of clay were gathered, it is very possible that the species mentioned belong to different horizons.

Neetzka and Oertzenhof being the sole localities in

Northern Germany which until then had yielded fossil Arctic plants, while nothing whatever was known of the existence of Arctic plant-fossils in Russia, Prof. O. Drude, of Dresden, in 1889 expressed the opinion<sup>1</sup> that the margin of the great northern inland ice might have been surrounded, not by an Arctic flora, but by a forest growth; and further, that such a growth may even have existed on the surface moraines of the inland ice itself.

I have<sup>2</sup> lately tried to show, however, that this hypothesis is erroneous; but with the conviction that facts would prove the best arguments, I resolved to visit those portions of Western Russia and Northern Germany which I had not previously examined, and, thanks to the liberality of the Swedish Society for Geography and Anthropology, who gave me the balance of the *Vega* fund, I have been enabled to carry out my project, with the results communicated below. As my collections are, however, only partially worked out as yet, the present notice must be considered as only preliminary.

The circumstances under which the Arctic plant-fossils occur are pretty uniform, and it may therefore be convenient to state them at once, instead of giving a description for every locality. In those parts of Western Russia and Northern Germany which I visited, the ground almost everywhere consists of a true *moraine profonde* (till) which has never been covered by the sea. Though marine glacial deposits are consequently absent in this area, fresh-water deposits, which have been formed in ancient lakes or ponds, are very abundant. These deposits consist generally in their lower part of a bluish clay or sandy clay, sometimes distinctly laminated, while the colour of the clay in the upper part is generally somewhat yellowish. This fresh-water clay is often covered by white shell marl, principally derived from the shells of fresh-water Mollusca; sometimes, however, by mud containing the remains of microscopic Algae, fragments and excrements of insects and other minute fresh-water animals. Then comes the peat, terminating the deposit above—sometimes developed as a true peat-moss; at others, only as a peaty mould 1 to 2 feet thick. In places the peat is totally absent, *i.e.* the fresh-water lake has been entirely filled up by the alluvial clay before the formation of peat had begun.

The Arctic plant-fossils are found principally in the clay, sometimes also in the white marl or mud, whilst only *Betula nana* ascends into the peat. Some fresh-water Mollusca are found together with the Arctic plants—namely, some species of *Pisidium*, *Limnaea ovata*, *Anodonta* or *Unio*, sometimes also *Cyclas cornea*. By studying the distribution of the Mollusca in the different horizons, the order of immigration of the different species can be ascertained, and we know now very well the manner in which this has taken place in Southern Sweden. Besides Mollusca, the Arctic plants are often accompanied by remains of beetles and by Ostracoda, such as *Cytheridea torosa* and others; and in one locality in Scania I have also found abundant remains of *Apus glacialis*. Finally, it is in this horizon that the remains of the reindeer are principally found in Southern Sweden, Denmark, and Northern Germany.

When travelling in Esthonia and Livonia I had the advantage of being accompanied by the well-known geologist, Akademiker Fr. Schmidt, of St. Petersburg, and the success of our investigations was largely due to his advice. The Arctic plant-fossils were first discovered at Kunda in Esthonia (7), where the fresh-water marl and clay are used in the preparation of cement. The upper part of this deposit has yielded a great many bone implements of Neolithic age, which were described some years ago by the late Prof. Grewingk, of Dorpat, and antlers of reindeer are likewise present. The Arctic plants were obtained at a depth of 173 feet below the

<sup>1</sup> *Petermann's Mittheilungen*, 1889, pp. 282-290.

<sup>2</sup> *Engler's Botan. Jahrbücher*, Bd. xiii, 1891, Beiblatt Nr. 23.

<sup>1</sup> It is curious that *Dryas octopetala* has not yet been reported from the glacial plant-fossils of Great Britain, although it abounds in the glacial fresh water deposits of Sweden, Denmark, Germany, and Russia; and although the plant still lives in the mountains of Scotland, Yorkshire, and Wales. May not, however, the leaf from Crofthead which Mr. Mahony has identified with *Scutellaria galericulata* (*Geol. Mag.*, vol. vi. p. 392) in reality have been a leaf of *Dryas*? The leaves of *Scutellaria* can hardly be preserved in the fossil state.

surface, *Salix polaris* being the most common form. Of other species found, the following have, up to the present, been recognized: *Salix herbacea*, *Dryas octopetala*, *Betula nana*, *Polygonum viviparum*, *Saxifraga cespitosa* or an allied species, mosses, &c.

From Kunda we went to Hellenorm in Livonia (8), where we were welcomed by the old Siberian traveller, A. Th. van Middendorff, who took a great interest in my researches. On the day of our arrival Prof. Schmidt found a leaf of *Salix reticulata* in a bed of clay at Samhof. In another clay-bed in the vicinity, at Kinzli, I found *Dryas octopetala*, *Betula nana*, *Salix* sp., mosses, &c.

Then we went to Fellin (9), where I found the Arctic plants at two different localities, Pingo and Wieratz. The species obtained were *Dryas octopetala*, *Betula nana*, *Salix reticulata*, *Potamogeton* sp., &c. I then parted from Prof. Schmidt, and went to Rjeshiza (10), in the Government of Vitbsk, accompanied by Dr. J. Klinge, of Dorpat. In Rjeshiza we were welcomed by Dr. E. Lehmann, a skilful botanist; and on the very day of our arrival we discovered the following Arctic plant-fossils, *Dryas octopetala*, *Betula nana*, *Polygonum viviparum*, &c., in two different localities in the vicinity of the town. My ignorance of the Russian language made it impossible for me to continue my researches further eastwards into the interior of the country, and I consequently turned westwards to Königsberg, in Eastern Prussia. There Prof. A. Jentzsch reminded me of the discovery of *Hyppum turgescens*, in an alluvial deposit at Kuhrische Nehrung, made by Berendt many years ago. As this is a mountain species, it is possible that it may have been found in a glacial fresh-water deposit, and this locality has consequently been indicated on the sketch map (11).

Accompanied by Prof. A. Jentzsch, of Königsberg, and by Prof. H. Conwentz, of Danzig, I now went to Marienburg, in Western Prussia, and at Schropo (12), about 10 kilometres south-east of this town, a locality yielding Arctic plant-fossils was discovered. They occur here under precisely the same conditions as in Scania or at Kunda, in Esthland; *Salix polaris* and *Dryas octopetala* being found in the lower strata, whilst *Betula nana* occurs somewhat higher. The next locality discovered was at Krampkewitz (13), near Lauenburg, in Pomerania, whither I had gone with Prof. Conwentz. The plant-fossils found were *Dryas octopetala*, *Betula nana*, and some others.

Owing to heavy rains, a visit to Breslau proved fruitless, and for the same reason the fresh-water deposits near Waren and Rostock were inaccessible, but acting on the advice of Prof. E. Geinitz, of Rostock, I examined a small peat-moss at Nantrow (15), north-east of Wismar, where I found *Betula nana* and some *Salix* in mud and sand underneath the peat. The following day I examined the sections at the great North Sea-Baltic Canal at Holtenua, north of Kiel (16), under the guidance of Prof. R. v. Fisher-Benzon, of Kiel. We succeeded in finding two fresh-water basins yielding plant-fossils. The first basin, of which only a small portion now remained, contained fruits of *Betula nana*, together with some other species, not yet determined, but probably indicating a sub-Arctic climate. In the other basin, which was also cut through by the canal, the glacial fresh-water strata underneath the peat were laid bare, yielding abundant leaves of *Salix polaris*, sometimes intermingled with those of *Dryas octopetala*, mosses, &c.

In view of these facts, thus briefly communicated, I think it may be accepted as proved that the Arctic flora flourished on the plains south and east of the Baltic round the margin of the ice-sheet, and some time after the inland ice had melted away (see the accompanying sketch map). There can also be hardly any doubt that this same flora may have lived round the margin of the great northern inland ice at the climax of the glaciation. For otherwise it is difficult to understand how it could

have obtained so great an extension as from Suffolk to Kunda, in Esthonia, or why it should have flourished during so long a time after the amelioration of the climate, which caused the melting of the ice, had commenced. The fresh-water deposits with Arctic plants are sometimes so thick that they probably indicate an interval of several thousand years, during which the Arctic flora prevailed. If the margin of the ice-sheet at the climax of glaciation had been surrounded by a forest growth, this ought still more to have existed round the margin of the retreating ice. But as we have shown that this is not the case, we are entitled to conclude that the Arctic flora formerly flourished, not only round the margin of the great northern inland ice, but probably also over a part at least of the area between this ice and the glaciers of the Alps. In connection with this, it ought not to be overlooked that the Arctic tundra-fauna, which Prof. Nehring discovered at Thiede, underneath the steppe-fauna, perfectly harmonizes with this view, as this locality is situated relatively near to the outermost margin of the great northern ice-sheet. The existence of *Salix polaris* in Suffolk and Norfolk may also be considered as a strong argument for the same hypothesis. Thus the theory advanced by E. Forbes so far back as 1846—that the Alpine flora of Europe, so far as it is identical with the flora of the Arctic and sub-Arctic zones of the Old World, is a fragment of a flora which was diffused from the north, and that the termination of the glacial epoch in Europe was marked by a recession of an Arctic fauna and flora northwards—may now be regarded as definitively proved.

A. G. NATHORST.

#### CYCLONES IN THE ARABIAN SEA<sup>2</sup>

THIS discussion was undertaken primarily by the Meteorological Office with the object of throwing some light on the very exceptional storm which was experienced at Aden in the summer of 1885, but advantage was taken of this opportunity to produce synchronous weather charts of the Arabian Sea for a limited period, since it was felt that such charts would be of especial interest, dealing as they do with a part of the ocean which is subject to the regular change of monsoon winds. The charts also exhibit the occurrence of a second cyclone which had originated over the eastern portion of the Arabian Sea before the full effect of the first disturbance had passed away. The Gulf of Aden and the northern portion of the North Indian Ocean are rarely visited by cyclones or typhoons, and consequently the occurrence in these waters, in the summer of 1885, of a violent cyclone, causing the loss of several vessels, among them the German corvette *Augusta*, and the French despatch-boat *Renard*, attracted considerable attention. The number of ships' logs which have been collected and utilized in the preparation of the charts is 239, and the information has been obtained from all available sources, including our own Navy and mercantile marine, and those of many foreign countries. For the first few days of the period discussed, the normal conditions were apparently prevailing over the Arabian Sea, the wind was north-westerly near the Indian Peninsula, but the south-west monsoon was blowing steadily near the African coast and for some distance over the sea on the western side of the district. Until about May 20, the weather in the neighbourhood of Ceylon seems to have been quiet, and the wind fairly steady from the south-westward. On the 20th, Her Majesty's ships *Erlon* and *Woodlark* experienced somewhat disturbed weather at Trincomalee, the squalls attained the force

<sup>2</sup> "Daily Weather Charts for the Period of Six Weeks ending June 25, 1885, to illustrate the Tracks of Two Cyclones in the Arabian Sea" (London: Published by the authority of the Meteorological Council, 1891.)

of a moderate gale from the north-westward, and much thunder and lightning occurred. Unsettled weather continued from the 21st to the 24th, and from this day a storm area can be clearly traced travelling to the westward. The cyclone reached its greatest violence on June 2 and 3, when the barometer is reported as reading 27.86 inches in close proximity to the centre of the disturbance. A hurricane occurred at Obokh during the evening of the 3rd, and it was reported that all the houses but one had been blown down, and trees had been uprooted. The position of the storm area is not only marked throughout its passage across the Arabian Sea by the cyclonic circulation of the winds, but also by the rain area which accompanied the disturbance; the rate of progress of the storm from May 24 to June 3 was rather less than seven miles an hour.

The second cyclone which is shown by the charts appears to have originated not far distant from Ceylon at the commencement of June, and on the 4th a strong south-westerly gale was blowing on the equator in the longitude of 76° E. This storm can be traced for the next ten days, during which time it passed to the northward and westward towards the entrance of the Persian Gulf. The weather was very disturbed over nearly the whole of the Arabian Sea from the 9th to the 13th, and the area of the storm was much larger than in the case of the Aden cyclone, and gales were experienced from the coast of Africa to that of India, extending over a distance of about 1500 miles. The synchronous weather charts for the last few days of the discussion, after the cyclonic disturbances had passed away, show that the south-west monsoon had extended over the whole of the Arabian Sea, whereas in the middle of May it was limited chiefly to the western side.

Each daily chart contains the observations from several ships in the Red Sea, where the wind direction and other elements of the weather are very instructive. The southerly march of the northerly or north-westerly wind, which throughout the whole period prevails over the northern portion of the Sea, and the gradual backing down of the southerly winds in the southern portion of the Sea are well shown. The northerly wind in the northern portion of the Red Sea often attains the force of a gale, but there is no instance in the charts of the southerly winds attaining gale force. The air temperature is generally higher in the Red Sea than over the more open water in the Arabian Sea, the reading of the thermometer commonly reaching 90°, and on June 14 the temperature at 10 o'clock in the morning was 102° over the open sea, nearly abreast of Musawwá. The charts show many other points of interest, among these the flow of the current under the influence of disturbed weather as well as when the sea is comparatively quiet, and doubtless the volume will throw some additional light on the winds and weather in this part of the world, where at present the meteorological changes are not too well understood.

ON VAN DER WAALS'S ISOTHERMAL EQUATION.

IN reply to Prof. Tait's criticism (NATURE, December 31, 1891, p. 199) of my paper (December 17, p. 152), I wish to say that I certainly do not consider Van der Waals's *b* as an absolute constant. Perhaps it may be interesting to show how the limits of its variability can be determined.

Leaving aside the question of the attractive forces, which probably has been sufficiently elucidated in the course of this discussion in the columns of NATURE, and considering gases as aggregations of elastic spheres, then in the formula—

$$p_1(v - xb_1) = \frac{1}{3} \Sigma mu^2 \dots \dots (1)$$

*x* can be proved to be equal to 4 for large volumes and small pressures.

Again, in the case of *extremely large* pressures, when the volume is nearly reduced to the smallest possible dimensions, it is easy to see that a formula—

$$p_1(v - \mu b_1) = \frac{1}{3} \lambda \cdot \Sigma mu^2 \dots \dots (2)$$

must hold good, where  $\mu b_1 = 3\sqrt{2}/\pi \cdot b_1 = 1.35 \dots b_1$  represents the space in which the spherical molecules can be inclosed when they are motionless, and  $\lambda$  is a certain numerical coefficient whose determination might present some interest, and perhaps is not beyond the scope of mathematical analysis. (For one-dimensional motion  $\lambda = 1$ .) Be this as it may, putting (2) in the form—

$$p_1 \left[ v - \left( 1 + \frac{\lambda - 1}{\lambda} \cdot \frac{v - \mu b_1}{\mu b_1} \right) \cdot \mu b_1 \right] = \frac{1}{3} \Sigma mu^2 \dots (3)$$

it is clear that in *this* case *x* approaches the value  $\mu = 1.35$ .

Now surely, for *intermediate* volumes and pressures,  $xb_1$  cannot be considered as a constant; still, along the large range of these pressures, the correction required must be called *relatively* slight, and the more so as it is beyond doubt that a considerable part of the change from 4 to 1.35 takes place near those extreme pressures where, according to (3), *x* may be very variable. Whether at the critical volume this coefficient has undergone already a practically important change from its original value, 4, seems to me a question which cannot easily be answered by purely theoretical considerations.

In my opinion, in all cases except in that of large volumes the formula (1) is preferable to a formula

$$p_1 v = \frac{1}{3} \left( 1 + \frac{4b_1}{v} + \frac{\sigma b_1^2}{v^2} \right) \cdot \Sigma mu^2 \dots (4)$$

even if the numerical value of  $\sigma$  could be exactly calculated; therefore the question at issue does not simply turn on the introduction or rejection of terms of the order  $\beta^2/v^2$ , and it was looking at the matter from this point of view that in my paper I once called a formula of the form (1) the *true one* as distinguished from a formula of the form (4), and not from any formula given by Prof. Tait. Certainly, none of the isothermal equations given by different authors can be named *true* in the sense of representing with absolute exactness the conduct of real gases; and of course, when more constants are introduced in these equations than are contained in that of Van der Waals, a better approximation to the conduct of these gases may be reached.

In conclusion, I beg to add a few words about Prof. Tait's third remark. It seems to me that he has no right to identify the process of putting arbitrarily  $\gamma = \beta$  with that of calculating the correction indicated by Prof. Lorentz. D. I. KORTEWEG.

Amsterdam, January 6.

NOTES.

SEVERAL scientific meetings have been postponed in consequence of the death of the Duke of Clarence. Prof. W. E. Ayrton, F.R.S., was to have delivered his inaugural address, as President of the Institution of Electrical Engineers, on January 14. It will be delivered at a meeting of the Institution on January 28. The annual general meeting of the Royal Meteorological Society, fixed for the 20th, will be held on the 27th, when the President, Mr. Baldwin Latham, will deliver an address on "Evaporation and Condensation." The annual meeting of the Entomological Society is also adjourned from the 20th to the 27th.

The forty-fifth annual general meeting of the Institution of Mechanical Engineers will be held on Thursday and Friday evenings, February 4 and 5, at 25 Great George Street, West-

minster. The chair will be taken at half-past seven p.m. on each evening. The President, Mr. Joseph Tomlinson, will retire, and will be succeeded by the President-elect, Dr. William Anderson. The following papers will be read and discussed, as far as time permits—Notes on mechanical features of the Liverpool water-works, and on the supply of power by pressure from the public mains, and by other means, by Mr. Joseph Parry, water engineer, Liverpool (Thursday). On the disposal and utilization of blast-furnace slag, by Mr. William Hawdon, of Middlesborough; communicated through Mr. Charles Cochrane, past-President (Friday).

THE German Mathematical Association (Deutsche Mathematiker-Vereinigung) propose to hold their annual meeting in the autumn of this year at Nuremberg, and at the same time an Exhibition of Mathematical and Physical Models and Apparatus is to be brought together under the auspices of the Government. This Exhibition will resemble that of the Loan Collection, held at the South Kensington Museum in 1876. At Nuremberg the corresponding Germanisches Museum is available for the same purpose. The German Mathematical Association request the concurrence and assistance of those persons and institutes interested in the subject in this country, so as to make the Exhibition as complete and representative as possible.

THE American Institute of Electrical Engineers has passed a resolution declaring its intention to co-operate with "the World's Congress Auxiliary" in the effort to secure the gathering of an International Electrical Congress at Chicago in 1893, and pledging itself to do everything in its power to make the Congress a successful and worthy representation of the best electrical science and practice in all parts of the world. According to a prospectus issued by the World's Congress Auxiliary, the Congress will deal with "scientific and technical electricity, telegraphy, telephony, electric light, electric power, and other forms of electrical application, with appropriate chapters and sections for the proper consideration of each."

THE friends of Prof. Baird, the late Secretary of the Smithsonian Institution, will regret to hear that his widow, Mrs. Spencer F. Baird, died at her home in Washington on December 23, 1891.

M. DE QUATREFAGES, the well-known anthropologist, died on Tuesday, January 12. He was born in 1810, and studied medicine at Strasburg. Afterwards he became Professor of Zoology at Toulouse, where he had settled as a medical practitioner. In 1855 he was made Professor of Anthropology and Ethnology at the Jardin des Plantes, Paris. He had already been admitted to the Academy of Sciences in 1852, and he was an honorary member of many foreign learned Societies. Numerous friends and pupils were present at his funeral, and addresses were delivered by M. Milne-Edwards, and other men of science. The most famous of his writings are his "Crania Ethnica" and "Études des Races Humaines."

MR. W. L. SCLATER, Deputy-Superintendent of the Indian Museum, Calcutta, has been appointed Curator of the Museum and Lecturer on Biology at Eton College.

IN a letter on "A Difficulty in Weismannism," published in NATURE on December 3, 1891 (p. 103), Prof. Hartog quoted some passages from a private letter he had received from Prof. Weismann. To this letter reference was made in a subsequent communication by Mr. A. H. Trow (p. 175). Prof. Hartog has sent us Prof. Weismann's letter, but we do not consider it necessary to print it, as the correspondence is now closed.

AN important and interesting paper on Chinese fibres appears in the new number of the *Kew Bulletin*. It seems that at Chinese ports there is much confusion as to the origin and classification of

these fibres, different fibres sometimes bearing the same name, while the same product often bears different names at different ports. This confusion is apparently due in part to the fact that European traders have used the terms "jute" and "hemp" in a generic rather than a specific sense; in part to the fact that the duty on "jute" is only "2 mace per picul," whereas "hemp" pay 3½ mace. The subject has lately been carefully investigated at Kew, and further inquiry is about to be made at the Chinese ports under the direction of Sir Robert Hart, Inspector-General of the Chinese Imperial maritime Customs. At Kew much help has been derived from specimens sent by the Acting Consul at Chefoo, Mr. Alexander Hosie, a report by whom is included in the paper in the *Bulletin*. A memorandum on the jute and hemp of China, by Dr. Augustine Henry, is also given. The question is one of considerable practical importance, as the confusion which prevails cannot but tend to hinder the development of trade.

ANOTHER interesting paper in the *Kew Bulletin* is on Ipoth poison of the Malay peninsula. It consists chiefly of a valuable report by Mr. Leonard Wray, Junior, Curator of the Perak Government Museum, who has sent to Kew an admirable series of specimens. The report is printed in advance of the results of the examination of the presumed poisonous fluids, which has again been undertaken by Dr. Sidney Ringer, F.R.S., Professor of Clinical Medicine, University College, London.

DR. BROWN LESTER, who accompanied the Gambia Delimitation Commission, made a botanical collection fairly representative of the flora in the neighbourhood of the River Gambia, as far as the dryness of the season would permit. The specimens have been determined at Kew; and a list of the determinations, with Dr. Brown Lester's brief notes, is given in the *Kew Bulletin*. From a botanical point of view, the collection, according to the *Bulletin*, is not of very great interest; but it is said to afford a useful picture of the character and productions of the country traversed.

IN an appendix to the latest number of the *Kew Bulletin*, a list is given of the staffs of the Royal Gardens, Kew, and of botanical departments and establishments at home, in India, and in the colonies, in correspondence with Kew. On two former occasions a list of the same kind has been issued in the *Kew Bulletin*; and it has been found of considerable value, as it affords a convenient means for placing on record the official titles and designations of the officers concerned, and renders possible the notification of the changes that take place in the several appointments. The new list includes an enumeration of the officers that have been selected to carry out the recently-organized botanical survey of India, with the districts allotted to each one. There is also a fuller list of officers in charge of gardens in Native States. The organization of the botanical department of the Leeward Islands brings into one group the several botanical stations existing in those islands.

MM. LABORDE AND RONDEAU have given, in the *Revue Mensuelle d'Anthropologie*, an account of recent experiments on the poison of the arrows of the Sarro savages, in the Upper Niger valley. Specimens were brought back by Lieutenant Jaime. From the physiological experiments performed, it would seem that the poison is identical with that of *Strophanthus*.

SEÑOR F. P. MORENO, who has been investigating some ancient graves in the Argentine Province, Catamarca, has found various objects which are likely to be of considerable importance in the study of American archaeology. He has secured 86 human skulls, 400 vases, 420 stone implements, 15 copper implements, and 110 objects made of bone. The skulls are of two different types, one set resembling those found in the graves at Ancon, Peru,



another those of Indians in Chaco and in the south of the Argentine Republic. All are brachycephalic, and many have been artificially distorted. The skulls of the Peruvian type are the later of the two groups. It is evident, however, that before the appearance of the Peruvian element; in what is now Catamarca the population were in a much higher position than the Indians of the present day. They built strong fortresses, like those which are found in Arizona and New Mexico, and the traces of their dwellings indicate a comparatively advanced stage of civilization. Many of the remains remind Señor Moreno of the Mexicans, others seem to show some affinity between the people and the Chibcha, while others are of a quite peculiar character. He has given a provisional account of his results in the *Revista de la Plata*, 1890-91.

MR. JAMES F. HOBART contributes to the January number of the *Engineering Magazine*, New York, an interesting article on the paper-making industry. He notes that while in 1881 the United States produced only 5,315,400 pounds of paper, it produced in 1891 not less than 15,219,580 pounds. Even this rate of production is exceeded by Germany. Mr. Hobart, however, thinks there are indications that the United States will lead the world in the production of paper before the end of the century.

THE new number of the *Board of Trade Journal* contains some extracts from a valuable report by the French Agent at Victoria on the salmon industry in British Columbia. Among the details noted by him is the fact that the best fish are almost always taken on the outflow of the river in the place where the fishermen endeavour to meet the fish on their arrival from the sea. A boat is often filled with several hundred fish in a single drift net of from 400 to 500 metres. It is calculated that on certain days the total of the Fraser fishery amounts to not less than 150,000 salmon, which are passed through all the different phases of preserving, and are ready to be forwarded for the market on the same day. An ingenious apparatus used to take the salmon, chiefly on the Columbia River in the United States, is described. A large wheel, fixed at a certain distance from the bank, is put in motion by the current. The blades of this wheel are provided with a network of iron wire intended to raise from the water any large object coming in contact with them. A sort of bar-work starting from the wheel is so placed as to increase the strength of the current in such a manner as to force the fish passing on this side of the river to go in this direction. The salmon, wishing to cross the very rapid stream where the wheel is placed, is raised out of the water by the iron wire on the blades. In the rotary movement the salmon is carried to the centre of the wheel, whence an inclined plane conducts it into vast open reservoirs in the stream, where it can be kept alive for some time. A system of pulleys provides for the raising of these reservoirs, the water flows out, and the salmon is carried in boat-loads just as it is required for preparation.

THE U.S. Consul at Bordeaux gives, in a recent report, some interesting information about the wines of the Medoc district. He notes that this district, between the sea on the one hand and the Garonne and Gironde Rivers on the others, is called Medoc (*quasi medio aquae*), because nearly surrounded by water. It is the northern termination of the extensive tract of sand-hills and marsh-land called "Les Landes," extending from Bayonne north, which changes to a bank of gravel on approaching the left bank of the Garonne, and contains some of the most precious vineyards in the world. The soil is of light pebble, and, indeed, on the spots where some of the best wine is produced it appears a mere heap of quartz mixed with the most sterile quality of earth. The best wine is not produced where the bush is most luxuriant, but on the thinner soils, where it is actually stunted, and where weeds disdain often to grow. Here the vine retains the sun's heat about its roots after sunset, so that its

juices are matured as much by night as by day. The accumulation of sand and pebbles of which this soil is composed is apparently the spoils of the Pyrenean rocks, brought down by the torrents tributary to the Garonne and other great rivers, and deposited in former ages on the borders of the sea. At a depth of 2 or 3 feet from the surface occurs a bed of indurated conglomerate, which requires to be broken up before the vine will grow.

THE latest publication issued by the Meteorological Council contains the harmonic analysis of hourly observations of air temperature and pressure at British Observatories. The computations as originally undertaken were designed to supply the analysis of the hourly observations made at Greenwich Observatory which were published in 1878; but subsequently it was determined to extend the investigation so as to include the observations made at the seven Observatories maintained by the Meteorological Office for a series of twelve years. The onerous work of calculation has been considerably diminished by means of the mechanical analyzer designed by Sir William Thomson, and by special formulæ, tables, and a slide rule prepared by General R. Strachey, Chairman of the Council. A drawing of the scale, and an explanation of its application, are given in the preface to the work.

THE Meteorological Council have just issued a useful publication entitled "Ten Years' Sunshine in the British Isles, 1881-90." The observations have been taken at forty-six stations, well distributed over the country—except for Scotland and Wales. At the great majority of stations the instrument used is the Campbell-Stokes sunshine-recorder, which focuses the sun's rays, by means of a glass ball, on to a card fixed in a brass frame. The instrument records only bright sunshine, which burns the card when no mist is present, or no cirrus or other clouds obstruct the rays. The tables show that December is the most sunless month of the year. Jersey stands first on the list of stations, as it does in nearly all other months of the year, having 23 per cent. of possible duration, while Dublin has 21 per cent., and St. Ann's Head 20 per cent., and London has a miserable record of 2 per cent. A great increase is noticeable in February, when Jersey has the greatest amount, viz. 31 per cent., and London the least, 9 per cent. In April, London begins to compare more favourably with other places situated in the suburbs, and May is the sunniest month of the year, while June and July are by no means as sunny as might be expected. August is a good month, except in the north-west of Ireland and Scotland. September and October exhibit a considerable decrease, and November is the only month in which the Channel Islands are not the most sunny part of the British Isles. The sea-coast generally is more sunny than inland parts, while large manufacturing cities, such as Glasgow, compare badly with stations in their neighbourhood. In the late autumn, Ireland generally receives more sunshine than the most of England.

It is useful, in relation to meteorology, to note the date of commencement of various harvest operations. A French Abbé, M. Buvé, has recently suggested a consideration of the quantity of sugar produced in certain plants as a means of determining the meteorological elements concerned in this process. The physiology of the sugar beet is now pretty well known; and, according to M. Marié Davy, one may estimate pretty closely the yield of this plant by means of calculations from the heat and illumination to which it has been subject. Conversely, the Abbé points out, we might determine the heat and light received, through the quantity of sugar produced. Fiscal operations, determining the yield of sugar, would facilitate the process. Again, it is suggested that the yield of honey might be considered in the same relation—the quantity of it in flowers depending greatly on sunshine, wind, rain, &c., while the state of the

atmosphere favours or hinders the work of bees. The summers of 1889 and 1890 are cited as presenting a marked contrast with regard to both beet-sugar and honey, in correspondence with weather-conditions; the earlier year was a highly prosperous one, the latter quite the opposite.

In the Report, just issued, of the U.S. Commission of Fish and Fisheries, on the fisheries of the great American lakes in 1885, it is noted that in Lake Michigan there is no fishing through the ice in the southern end of the lake, but that in the northern end, especially in Green Bay and along the north shore, this fishery is extensive. For twenty years it has given employment to a very large number of men living in the neighbourhood of Green Bay, and many fishermen from other localities have found work there during the winter months. During the winter season the bay used to present greater activity than the surrounding land, hundreds of shanties and temporary huts being built for shelter. Dealers drove about from place to place on the ice to purchase the catch, and merchants sent waggons with provisions for the fishermen. At the height of the season it was not uncommon for the fishermen to bring their families out to the fishing quarters, where they would remain for some weeks, all hands helping to keep the nets in repair. For several years this fishery, owing to the diminished quantity of white-fish, has been less extensive, and the fishermen engaged in it at present generally live at home, owning a horse and sleigh, which enable them to visit their nets daily.

At a recent meeting of the Field Naturalists' Club of Victoria, Baron von Mueller advocated strongly the protection of insectivorous and native birds in the colony. He thought that this object might be attained, not only by putting a comparatively heavy tax upon guns and by more strictly enforcing the present laws, but by the initiation of some scheme which would enlist the sympathy and co-operation of all persons interested in the subject. He suggested that a distinctive badge might be worn by members if such a union were ever formed.

The Académie Royale des Sciences, des Lettres, et des Beaux Arts de Belgique has issued its *Annuaire* for 1892. It contains, besides much information as to the organization and activity of the Academy, biographical sketches of deceased members, with remarkably good portraits.

An interesting memoir is contributed by Dr. Merz, of Zurich, to the current number of the *Berichte*, concerning the compound of nitrogen and magnesium, generally known as magnesium nitride,  $Mg_3N_2$ . Magnesium, like boron, appears to possess a somewhat powerful affinity for nitrogen. Some years ago Deville and Caron, during their distillations of magnesium for the purpose of obtaining the pure metal, observed the presence of small transparent crystals, containing only magnesium and nitrogen, upon the surface of the distilled metal. More recently, Briegleb and Geuther have shown that nitride of magnesium in an amorphous form may be prepared by heating magnesium filings in a porcelain boat placed within a porcelain tube traversed by a stream of nitrogen. Dr. Merz now describes two extremely simple methods of obtaining the nitride, suitable for lecture demonstration, and also some further properties of this interesting substance. A quantity of finely-powdered and carefully dried magnesium, about two grams in weight, is placed in a wide piece of combustion tubing about twenty centimetres long, closed at one end. Attached to the open end of this tube by means of a wide caoutchouc connection is a narrower tube closed by a caoutchouc stopper, through which passes the nitrogen delivery tube. A short side-tube blown upon the narrower tube carrying the stopper serves for the exit of the gas, and is connected by narrow caoutchouc tubing with a long vertical tube bent round parallel to itself, the open end of which dips beneath

the surface of some coloured water. The air is first displaced from the whole apparatus by means of pure dry nitrogen, and when this is accomplished, the combustion tube containing the magnesium, laid nearly horizontally, is heated by means of a triple Bunsen burner. After two or three minutes have elapsed from the attainment of a red heat, the speed of the current of nitrogen may be slackened by means of a screw clip placed somewhere in its path, when the coloured water will rapidly rise in the vertical tube, attaining a height of ten feet, if the tube is so long, in a couple of minutes, thus exhibiting in a graphic manner the rapid absorption of the nitrogen by the magnesium. On allowing the experiment to proceed for upwards of an hour, almost the whole of the magnesium is converted to nitride, the small remainder reacting with the glass, and producing a black mirror of silicon. Magnesium nitride obtained by this method is a light, voluminous, friable, and yellowish-gray-coloured substance when cold, but reddish-brown while hot. When exposed to the air, it smells strongly of ammonia, owing to its decomposition by the moisture present. When a little water is poured upon it, great rise of temperature occurs, together with hissing, increase in volume, and evolution of steam, just as when quicklime is slaked. Ammonia is also evolved in large quantities, and white magnesium hydrate remains. The decomposition by means of water is most effective when performed at the bottom of a large flask, which rapidly becomes filled with ammonia gas; the moment a little hydrochloric acid is introduced upon a feather or other convenient carrier, the flask becomes filled with dense fumes of ammonium chloride. Dr. Merz further shows that the nitride may likewise be obtained by heating magnesium in a current of dry ammonia to a temperature considerably lower than that which is required in the case of free nitrogen, and very much lower than that employed by Briegleb and Geuther in some similar experiments made by them. As soon as this temperature is attained, a brilliant incandescence occurs, and the flame may be removed; hydrogen is evolved in a rapid stream, and 95 per cent. of the magnesium is converted in three or four minutes to nitride.

The additions to the Zoological Society's Gardens during the past week include a Green Monkey (*Cercopithecus callitrichus* ♂), a Sooty Mangabey (*Cercocebus fuliginosus* ♀) from West Africa, presented by Canon Taylor Smith; a Moustache Monkey (*Cercopithecus cephus* ♂) from West Africa, presented by Mr. Alfred Lloyd; a Silver-backed Fox (*Canis chama*) from Damaraland, South Africa, presented by Mr. E. Aubrey Hart; two Virginian Opossums (*Didelphys virginiana*) from North America, presented by Mr. John Brinsmead, F.Z.S.; a Common Jay (*Garrulus glandarius*), British, presented by Mr. Charles Faulkner; a Great Titmouse (*Parus major*), a Coal Titmouse (*Parus ater*), a Blue Titmouse (*Parus caeruleus*), British, presented by Captain Salvin; a Bonham's Partridge (*Anmoperdix bonhami*) from Western Asia, deposited; a Bronze-winged Pigeon (*Phaps chalcoptera* ♀) from Australia, purchased.

#### OUR ASTRONOMICAL COLUMN.

MOTION OF STARS IN THE LINE OF SIGHT.—Prof. H. C. Vogel, in *Monthly Notices R.A.S.* for December 1891, fully describes the method used at Potsdam for determining the velocity of stars in the line of sight, and states the chief results that have been obtained since the work was begun in 1887. In order to insure great stability with the smallest possible weight, the frame of the spectroscope is made of cast steel. The camera is also constructed of steel, and the dark slides are of brass. It may be worth remarking, however, in this connection, that stability would have been secured if aluminium had been used instead of steel and brass, and this with a little more than one-third the weight. A spectroscope similar to Prof. Vogel's, but

with an aluminium frame, has been made for the Observatory at Kensington, and gives every satisfaction. The comparison spectrum used at Potsdam has been furnished by a Geissler tube placed directly in the cone of rays of the refractor, at a distance of 40 cm. from the slit, the tube being at right angles to the optical axis of the refractor and the slit. The slit is set parallel to the line of the diurnal motion, and width is given to the spectrum by making the driving clock move slightly slower or faster than its proper rate. A uniform exposure of one hour has been employed, the proper intensity being obtained by changing the rate of the driving-clock, so that the error increases with increase of brightness. The photographs are measured with the aid of a microscope having a sliding apparatus on its table, movable by a fine micrometer screw. One revolution of the screw corresponds to a difference of wave-length of 0.324  $\mu$ , which, expressed in miles per second, is 139.13. After describing the methods of measuring the displacement of lines in stars of different types of spectra, Prof. Vogel brings together the results which have formed the subject of several previous communications. It is said that the probable error in the determination of the radial velocity of a star of Class II. is  $\pm 1.34$  miles per second, and for stars of Class I.,  $\pm 2.31$  miles. Measurements have been made independently by Prof. Vogel and Dr. Scheiner, and each star has been observed on the average 3.3 times, therefore it is concluded "that the probable error of the definitive values for both spectral classes will amount to less than one mile." A list of the observed velocities of forty-seven stars will soon be published. The mean motion in the line of sight is 10.6 English miles per second; six stars have a velocity less than 2 miles per second, and five greater than 20 miles. A Tauri heads the list with a velocity of about + 36 miles per second. Fifteen of the stars have a positive, and thirty-two a negative motion.

**ORTHOCHROMATIC PLATES FOR ASTRONOMICAL PHOTOGRAPHY.**—MM. Fabre and Andoyer photographed the eclipsed moon at Toulouse Observatory on November 13, 1891; and some of the pictures obtained were exhibited by them at the meeting of the Paris Academy of January 11, with a note on the method of production. Collodion-bromide and collodion-chloride plates were employed, both kinds being treated with eosin and cyanin to render them orthochromatic. The former kind of plate was found to be relatively more sensitive to red and yellow rays than the latter, although both were stained with the same dyes. It is proposed, therefore, to use collodion-bromide orthochromatic plates to obtain photographs of Mars, Jupiter and the red spot, and coloured stars.

### DREDGING OPERATIONS IN THE EASTERN PACIFIC.

THE *Bulletin* of the Museum of Comparative Zoology at Harvard College, published in June, contains three letters from Prof. Alexander Agassiz to the Hon. Marshall McDonald, United States Commissioner of Fish and Fisheries, on the dredging operations off the west coast of Central America to the Galapagos, to the west coast of Mexico, and in the Gulf of California. The operations, which were in charge of Prof. Agassiz, were carried on by the U.S. Fish Commission steamer *Albatross*, Lieutenant Commander Z. L. Tanner, U.S.N., commanding.

I.

Steamer "*Albatross*," Panama, U.S. of Colombia,  
March 14, 1891.

MY DEAR COLONEL McDONALD,—We returned yesterday from our first trip. The route extended from Panama to Point Mala, and next to Cocos Island; from there we ran in a southerly direction, then north-westerly to Malpelo Island, and back to the hundred-fathom line off the Bay of Panama. We spent several days trawling off the continental plateau of the Bay. This trip being rather in the nature of a feeler, I cannot tell you just what I think it means. But I believe I can to some extent conjecture probabilities from what has been accomplished.

I have found, in the first place, a great many of my old West Indian friends. In nearly all the groups of marine forms among the Fishes, Crustacea, Worms, Mollusks, Echinoderms, and Polyps, we have found familiar West Indian types or east coast forms, and have also found quite a number of forms whose wide

geographical distribution was already known, and is now extended to the Eastern Pacific. This was naturally to be expected from the fact that the district we are exploring is practically a new field, nothing having been done except what the *Albatross* herself has accomplished along the west coast of North and South America. The *Challenger*, as you will remember, came from Japan to the Sandwich Islands, and from there south across to Juan Fernandez, leaving, as it were, a huge field, of which we are attacking the middle wedge. As far as we have gone, it seems very evident that, even in deep water, there is on this west coast of Central America a considerable fauna which finds its parallel in the West Indies, and recalls the pre-Cretaceous times when the Caribbean Sea was practically a bay of the Pacific. There are, indeed, a number of genera in the deep water, and to some extent also in the shallower depths, which show far greater affinity with the Pacific than with the Atlantic fauna. Of course, further exploration may show that some of these genera are simply genera of a wider geographical distribution; but I think a sufficiently large portion of the deep-sea fauna will still attest the former connection of the Pacific and the Atlantic.

I am thus far somewhat disappointed in the richness of the deep sea fauna in the Panamic district. It certainly does not compare with that of the West Indian or Eastern United States side. I have little doubt that this comparative poverty is due to the absence of a great oceanic current like the Gulf Stream, bringing with it on its surface a large amount of food which serves to supply the deep-sea fauna along its course. In the regions we have explored up to this time, currents from the north and from the south meet, and then are diverted to a westerly direction, forming a sort of current doldrums, turning west or east or south or north according to the direction of the prevailing wind. The amount of food which these currents carry is small compared with that drifting along the course of the Gulf Stream. I was also greatly surprised at the poverty of the surface fauna. Except on one occasion, when, during a calm, we passed through a large field of floating surface material, we usually encountered very little. It is composed mainly of Salpæ, Doliolum, Sagittas, and a few Siphonophores—a striking contrast to the wealth of the surface fauna to be met with in a calm day in the Gulf of Mexico, near the Tortugas, or in the main current of the Gulf Stream as it sweeps by the Florida Reef or the Cuban coast near Havana. We also found great difficulty in trawling, owing to the considerable irregularities of the bottom. When trawling from north to south, we seemed to cut across submarine ridges, and it was only while trawling from east to west that we generally maintained a fairly uniform depth. During the first cruise we made nearly fifty hauls of the trawl, and, in addition, several stations were occupied in trawling at intermediate depths. In my dredgings in the Gulf of Mexico, off the West Indies, and in the Caribbean, my attention had already been called to the immense amount of vegetable matter dredged up from a depth of over 1500 fathoms, on the lee side of the West Indian Islands. But in none of the dredgings we made on the Atlantic side of the Isthmus did we come upon such masses of decomposed vegetable matter as we found on this expedition. There was hardly a haul taken which did not supply a large quantity of water-logged wood, and more or less fresh twigs, leaves, seeds, and fruits, in all possible stages of decomposition. This was especially noteworthy in the line from the mainland to Cocos Island, and certainly offers a very practical object-lesson regarding the manner in which that island must have received its vegetable products. It is only about 275 miles from the mainland, and its flora, so similar to that of the adjacent coast, tells its own story. Malpelo, on the contrary, which is an inaccessible rock with vertical sides, and destitute of any soil formed from the disintegration of the rocks, has remained comparatively barren, in spite of its closer proximity to the mainland.

The most interesting things we have found up to this time are representatives of the Ceratias group of Fishes, which the naturalists of the *Albatross* tell me they have not met before on the west coast of North America. The Crustacea have supplied us with a most remarkable type of the Willemoesia group. The paucity of Mollusks, and also of Echini, is most striking, although we brought up in one of the hauls numerous fragments of what must have been a gigantic species of Cystechinus, which I hope I may reconstruct. We were also fortunate enough to find a single specimen of Calamocrinus off Morro Puerco, in 700 fathoms, a part of the stem with the base,

showing its mode of attachment to be similar to that of the fossil Apicorinidae. The number of Ophiurans was remarkably small as compared with the fauna of deep waters on the Atlantic side, where it often seems as if Ophiurans had been the first and only objects created. The absence of deep-sea corals is also quite striking. They play so important a part in the fauna of the deeper waters of the West Indies, that the contrast is most marked. Gorgonias and other Halcyonoids are likewise uncommon. We have found but few Siliceous Sponges, and all of well-known types. Star-fishes are abundant, and are as well represented in the variety of genera and species as on the Atlantic side of the Isthmus. I may also mention the large number of deep-sea Holothurians (Eliaspoda) which we obtained, as well as a most remarkable deep-sea Actinian, closely allied to *Cerianthus*, but evidently belonging to a new family of that group. We found the usual types of deep-sea West Indian Annelids, occasionally sweeping over large tracts of mud tubes in the region of green mud. Although we dredged frequently in most characteristic Globigerina ooze, I was much struck with the absence of living Globigerinae on the surface. Only on two occasions during a calm did we come across any number of surface Globigerinae and Orbulinae. On one occasion the trawl came up literally filled with masses of a species of *Rhabdamina* closely allied to *R. lineata*. Thus far, no pelagic Algae have been met with.

It is interesting to note that at two localities we came across patches of modern greensand similar in formation to the patches discovered off the east coast of the United States by the earlier dredgings of the Coast Survey, of Pourtales, and of the *Blake*. Having always been more or less interested in pelagic fauna, and having paid considerable attention to its vertical distribution during my earlier cruises in the *Blake*, I was naturally anxious to reconcile the conflicting statements and experiences of the naturalists of the *Challenger* and *Gazelle* on one side, and my own observations on the other. Both Murray and Studer contended that, in addition to the deep-sea and pelagic fauna, there was what might be called an intermediate fauna, with characteristic species, having nothing in common with the other two; while I maintained, on the other hand, from my experiments in the *Blake*, that there was no such intermediate fauna, but that the pelagic fauna might descend to a considerable depth during the daytime to escape the effects of light, heat, and the disturbing influence of surface winds, and that this surface fauna on the Atlantic side—off shore in deep water—did not descend much deeper than 150 to 200 fathoms. In order to test this point, Dr. Chun, under the auspices of the Naples Station, made an expedition to the Ponza Islands. Dr. Chun applied to a tow-net an apparatus for closing it, similar to the propeller in use on our thermometer and water-caps. He towed to a depth of 1400 metres, if I am not mistaken, but never at any great distance from the mainland or from the islands of the Gulf of Naples, and came to the conclusion that the pelagic fauna existed all the way to the bottom. At the time, I considered his experiments inconclusive, and was, of course, anxious to repeat them in a strictly oceanic district, in great depths, and at a considerable distance from shore. I had an apparatus constructed by Ballauf, of Washington, similar to that used by Dr. Chun. Unfortunately, in testing it we found the pressure of the tow-net against the propeller shaft so great as to make the machine useless, or, at any rate, most unreliable. Thanks to the ingenuity of Captain Tanner, we overcame these obstacles. He devised a net which could be closed at any depth by a messenger, and which worked to perfection at 200, 400, 300, and 1000 fathoms, and had the great advantage of bringing up anything it might find on its way up above the level at which it was towed. The lower part of the bag alone was closed by a double set of slings pulled by two weights liberated from a bell crank by a messenger. We found that, in towing the net at 200 fathoms for twenty minutes, we got everything in any way characteristic of the surface fauna which we had fished up with the tow-net at the surface. In addition to this, we brought up five species of so-called deep-sea Fishes, *Scopelus*, *Gonostoma*, *Beryx*, and two others, which had thus far been brought up in the trawl, and considered characteristic of deep water. Also a peculiar Amphipod, and the young of the new species of *Willemoesia* mentioned above. We then tried the same net at 300 and 400 fathoms, and in neither case did we bring up anything in the closed part of the bag, while the upper open part brought up just what we had found previously at a depth of 200 fathoms, plainly showing that in this district the surface fauna goes down

to a depth of 200 fathoms, and no farther. Next came our single attempt to bring up what might be found, say within 100 fathoms of the bottom, and Captain Tanner's net was towed at a depth of 1000 fathoms where the soundings recorded 1100. Unfortunately, we deepened our water while towing only twenty minutes to over 1400 fathoms, so that we failed in our exact object. But we brought up in the closed part of the bag two species of Crustacea, a *Macruran* and an Amphipod, both entirely unlike anything we had obtained before. I hope in the next cruise to follow this up, and determine also the upper limits of the free-swimming deep-sea fauna. In the upper part of the bag (the open part) we brought up a couple of so-called deep-sea Medusae, which must have been collected at a comparatively moderate depth, judging from their perfect state of preservation.

I can hardly express my satisfaction at having the opportunity to carry on this deep-sea work on the *Albatross*. While of course I knew in a general way the great facilities the ship afforded, I did not fully realize the capacity of the equipment until I came to make use of it myself. I could not but contrast the luxurious and thoroughly convenient appointments of the *Albatross* with my previous experiences. The laboratory, with its ingenious arrangements and its excellent accommodations for work by day and by night, was to me a revelation. The assistance of Messrs. Townsend and Miller in the care of the specimens was most welcome, giving me ample time to examine the specimens during the process of assorting them, and to make such notes as I could between successive hauls, while paying some attention also to the work of the artist, Mr. Westergren. He has found his time fully occupied, and we have in this trip brought together a considerable number of coloured drawings, giving an excellent general idea of the appearance of the inhabitants of the deep waters as they first come up. These drawings can be used to great advantage with the specimens in making the final illustrations to accompany the reports of the specialists who may have charge of working up the different departments. . . .

We left Panama on February 22, and returned to Panama after an absence of twenty days.

## II.

"*Albatross*," *Acapulco*, April 14, 1891.

We have reached the end of our second line of explorations. After coaling we left Panama, and reached Galera Point, where we began our line across the Humboldt Current, which was to give us a fair idea of the fauna of that part of the coast as far as the southern face of the Galapagos. With the exception of three good casts, the trawling on that part of the sea bottom proved comparatively poor, nor did the sea face of the southern slope of the Galapagos give us anything like the rich fauna I had expected. Theoretically, it seemed certain that a sea face like that of the Galapagos, bathed as it is by a great current coming from the south and impinging upon its slope, and carrying upon its surface a mass of animal food, could not fail to constitute a most favourable set of conditions for the subsistence and development of a rich deep-sea fauna.

In the deeper parts of the channel between Galera Point and the southern face of Chatham Island, we found a great number of Eliaspoda, among them several genera like *Peniagone*, *Bathodytes*, and *Euphrosyne*, previously represented by numerous species. The Star-fishes of this, our second cruise, did not differ materially from those collected during our first trip, but we added some fine species of *Freyella*, *Hymenaster*, *Astrogonium*, *Asterina*, and *Archasteridae* to our collections. Among the Sea-urchins on two occasions we brought up fine hauls of a species of *Cystechinus* with a hard test, many specimens of which were in admirable state of preservation. Among the Ophiurans nothing of importance was added, unless I may except a lot of *Ophiocreas* attached to a *Primnoa*, and a pretty species of *Sigsbee* attached to a species of *Allopora*, from the south side of Chatham Island.

The Gorgonians were remarkably few in number, which is undoubtedly due to the unfavourable nature of the bottom we worked upon. Nearly everywhere except on the face of the Galapagos slope we trawled upon a bottom either muddy or composed of Globigerina ooze, more or less contaminated with terrestrial deposits, and frequently covered with a great amount of decayed vegetable matter. We scarcely made a single haul of the trawl which did not bring up a considerable amount of decayed vegetable matter, and frequently logs, branches, twigs, seeds, leaves, fruits, much as during our first cruise.

Our Crustaceans, from the nature of the bottom, naturally consisted of the same groups of deep-sea types which we obtained before. I may, however, mention a haul containing a goodly number of *Nephrops*, a genus we had not previously obtained.

Among the Worms the Maldanidæ and Limicolous types were unusually abundant at some localities, the empty mud tubes often filling the bottom of the trawl. Some very large specimens of *Trochonia* were collected, and remarkably brilliantly coloured (orange and carmine) Nemertean and Planarians.

The Mollusks were very scanty, and the absence of *Comatulæ* or other Crinoids was equally disappointing, even when trawling on the extension of the line started three years ago by the *Albatross*, on the eastern face of the Galapagos slope, when on her way from Chatham Island to San Francisco. We took up this line off Indefatigable Island, hoping to obtain from that quarter our best results, but our hauls were very disappointing. The ground proved not only most difficult to dredge upon, but also comparatively barren, and it was not till we got into the oceanic basin again, between the Galapagos and Acapulco, that our catches improved. But even then they were not to be compared with the hauls at similar depths in the Atlantic off the West Indies, or along the course of the Gulf Stream.

Among the Fishes, our most important catches were fine specimens of *Bathynous*, of *Bathyrhissa*, of *Bathyrhoides*, and a few specimens of *Ipnos* in excellent condition.

From the nature of the bottom we naturally expected rich hauls of Siliceous Sponges, but we did not find many, and I do not think there were many novelties among those we have collected. On two occasions, a number of specimens of *Ascidians* were brought up; among them was a fine white translucent *Corinacidia*.

Among the Bryozoans, the most noteworthy haul was a number of beautiful specimens of the delicate *Naresia*, in excellent condition. On the line from the Galapagos to Acapulco we brought up a good many *Foraminifera* from the mud bottoms. On several occasions the bottom must have been covered with huge masses of a new type of an arenaceous *Foraminifer*, forming immense curling sheets attached by one edge to stones or sunk into the mud. This *Foraminifer* seems to increase in size by forming irregular more or less concentric crescent-shaped rings. When it comes to the surface, it is of a dark olive-green colour.

During this second cruise we continued our experiments with the Tanner closing tow-net, in order to determine the lower limits of the surface pelagic fauna, and to determine also if there is any so-called intermediate pelagic fauna at other depths, or within a short distance from the bottom.

On March 25, at a point not quite half-way between Cape San Francisco and the Galapagos, in 1832 fathoms of water, the Tanner net was sent down to tow at a depth which varied from 1739 to 1773 fathoms. The net was towed within these limits for a period of something over twenty minutes. The messenger was then sent down to close the net; time occupied seven minutes. The net was then drawn up to the surface. The lower part of it was found to have closed perfectly, and contained nothing beyond a few fragments of leaves. The lower bag was carefully washed in water which had been strained, and the water examined with all possible care, and sifted again. It contained nothing. The upper part of the net, however, which had remained open on its way up, was found to contain the identical surface things which on former occasions we had found in the Tanner net down to a depth of 200 fathoms. They were a small species of *Sagitta*, and species of *Doliolum*, *Appendicularia*, a huge *Sagitta*, a large number of *Leucifer* and *Sergestes*, and several species of *Schizopods* and *Copepods*; two species of *Hyperia*, probably parasitic on a *Salpa*, which was also quite abundant; several finely coloured *Calanus*, some *Iso-pods*, and a number of fragments of what must have been a very large *Beroe*, measuring from five to six inches in diameter; *Leptocephalus*, several specimens of *Stomias*, of *Scopelus*, of *Melamphes*, and other species, many of which, like some of the *Schizopods*, had been considered as typical deep-sea forms. Among the so-called deep-sea *Medusæ*, several specimens of *Atolla* and *Periphylla* were also found in the open part of the net. I may mention also as of special interest a huge *Ostracod*, allied to *Crossophorus*, with a thin semi-transparent carapace, and measuring somewhat more than one inch in length. The largest *Ostracod* previously known is not more than one-third of an inch long. On two other occasions this same *Ostracod* was brought up in the tow-net from a depth of less than 200 fathoms.

The surface at this point was also examined with the tow-net, and the pelagic animals found to be the same as those brought up in the open part of the tow-net on its way from the bottom. The number both of species and specimens was, however, much less than in the Tanner net. On the following day the Tanner tow-net was sent to be towed at a depth of 214 fathoms. In twenty minutes the messenger was sent down and the net hauled up. The bottom part of the net came up tightly closed. Its contents were examined in the same manner as before in well sifted water, and the water was found to be absolutely barren, while the upper part of the net, which came up open, and was not more than eight or nine minutes on the way, was well filled with surface life. The net contained this time a number of *Hyalæas* and *Criseis*, in addition to the things collected the day before. An examination of the surface fauna at this same point with the tow-net showed the presence only in smaller numbers of the same species which the open part of the same net contained, except that there were a larger number of bells and fragments of *Diphyes* and of *Cristalloides* than in the Tanner net. The point at which this experiment was made was about 250 miles from the Galapagos, and about the same distance from Cape San Francisco. There were myriads of *Nautiograpsus* swarming on the surface of the water; they literally lifted the surface tow-net. On two other occasions, once at a distance of 350 miles in a south-easterly direction from Acapulco (depth 232 fathoms), we tried the same experiment with the Tanner net, and invariably with the same result. The net was towed at a depth of 100, of 200, and of 300 fathoms, each time for twenty minutes, the messenger sent down, and the bottom part closed. At the depth of 100 fathoms, the closed part of the net contained practically the same things as the open part of the net; at 200 fathoms, the lower part of the net contained but few specimens of the surface life; and at 300 fathoms, the closed bottom net came up empty.

On the following day the surface was carefully examined, and the tow net sent to 175 fathoms, where it was towed for twenty minutes, and the messenger sent down to close it. The lower net came up well filled with the surface pelagic species, which on this day were unusually varied, it having been smooth and calm the previous night, and the morning before the towing was made. This haul was made in the evening, at 8 p.m. The previous hauls had been made at about 10 a.m., in a brilliant sunlight. Again, on April 11, about thirty miles south-east of Acapulco, in a depth of over 1800 fathoms, the Tanner net was sent to a depth of 300 fathoms, and the messenger sent down to close it. There was nothing in the lower part of the net which had been closed, while the open part contained an unusually rich assortment of surface species, and among them a large number of *Scopelus*, of *Schizopods*, and of *Rhizopods*, mainly *Collozoum* and *Acanthometra*.

These experiments seem to prove conclusively that in the open sea, even when close to the land, the surface pelagic fauna does not descend beyond a depth of 200 fathoms, and that there is no intermediate pelagic fauna living between that depth and the bottom, and that even the free-swimming bottom species do not rise to any great distance, as we found no trace of anything within 60 fathoms from the bottom, where it had been fairly populated.

The experiments of Chun regarding the distribution of the pelagic fauna have all been made in the Mediterranean, within a comparatively short distance from the shore, and in a closed basin showing, as is well known, special physical conditions, its temperature to its greatest depths being considerably higher than the temperature of oceanic basins at the limit of 200 fathoms, or thereabout, which we assume now to be the limit of the bathymetrical range of the true oceanic pelagic fauna. At 200 fathoms our temperature was from 49° to 53°, while, as is well known, the temperature of the Mediterranean soon falls at 100 fathoms even to about 56°, a temperature which is continued to the bottom in this closed basin. Of course, if temperature is one of the factors affecting bathymetrical distribution, there is no reason except the absence of light which would prevent the surface pelagic fauna from finding conditions of temperature at the greatest depth similar to those which the surface fauna finds within the limit of 200 fathoms in an open oceanic basin.

Arriving as we did at the Galapagos at the beginning of a remarkably early rainy season, I could not help contrasting the green appearance of the slopes of the islands, covered as they were by a comparatively thick growth of bushes, shrubs, and

trees, to the description given of them by Darwin, who represents them in the height of the dry season as the supreme expression of desolation and barrenness. Of course, here and there were extensive tracts on the sea-shore where there was nothing to be seen but blocks of volcanic ashes, with an occasional cactus standing in bold relief, or a series of mud volcanoes, or a huge black field of volcanic rocks, an ancient flow from some crater to the sea; but as a rule the larger islands presented wide areas of rich fertile soil, suitable for cultivation. The experiments at Charles Island, where there is a deserted plantation, and at Chatham Island, where Mr. Cobos has under successful cultivation a large plantation producing sugar, coffee, and all the tropical fruits, as well as extensive tracts on which his herds of cattle, sheep, and donkeys roam towards the higher central parts of the island, show the fertility of these islands. They are indeed as favourably situated for cultivation as the Sandwich Islands or Mauritius, and there is no reason why, if properly managed, they should not in the near future yield to their owners as large returns as do those islands.

I obtained from Mr. Cobos a piece of the so-called sandstone, said to occur on Indefatigable Island, and which of course I was most anxious to see, as the occurrence of true sandstone would have put quite a different face on the geological history of the Galapagos from the one usually received. This I found to be nothing but coral rock limestone, either a breccia, or slightly oolitic, identical with the formation found back of the beach at Wreck Bay on Chatham Island. I found there an old coral rock beach, extending on the flat behind the present beach, composed entirely of fragments of corals, of mollusks, and other invertebrates, cemented together into a moderately compact oolitic limestone, which when discoloured, as it often is, and turned gray, would readily be mistaken for sandstone. This coral rock is covered by just such a thin, ringing coating of limestone as characterizes the modern reef rock of other localities. On nearly all the islands there are a number of sandy beaches made up of decomposed fragments of corals and other invertebrates, and cemented together at or beyond high-water mark into the modern reef rock I have described. The coral is mainly made up of fragments of *Pocillopora*, which is found covering more or less extensive patches off these coral sand beaches, but which, as is well known, never forms true coral reef in the Panamic district. The only true coral reef belonging to this district is that of Clipperton Island (if we can trust the Admiralty charts), situated about 700 miles to the south-west of Acapulco. But neither at Cocos Island, nor at the Galapagos, nor anywhere in the Panamic district, do we find true coral reefs—nothing but isolated patches of reef-building coral. The absence of coral reefs in this district has of course already been noted by other naturalists, who have been struck by this feature in an equatorial region. Dana has ascribed it to the lower temperature of the water due to the action of the Humboldt current coming from the south, pouring into the Bay of Panama, and then flowing westward with the colder northerly current coming down the west coast of Mexico and Central America. From the investigations made this year by the *Albatross*, I am more inclined to assume that the true cause of the absence of coral reefs on the west coast of Central America is due to the immense amount of silt which is brought down the hill and mountain sides every rainy season, and which simply covers the floor of the ocean to a very considerable distance from the land, the land deposits being found by us even on the line from the Galapagos to Acapulco at the most distant point from the shore to the side or extremities. The mud in Panama Bay to the hundred-fathom line is something extraordinary, and its influence on the growth of coral reefs is undoubtedly greatly increased from the large amount of decomposed vegetable matter which is mixed with the terrigenous deposits.

The course of the currents along the Mexican and the Central and South American coasts clearly indicates to us the sources from which the fauna and flora of the volcanic group of the Galapagos has derived its origin. The distance from the coast of Ecuador (Galera Point and Cape San Francisco) is in a direct line not much over 500 miles, and that from the Costa Rica coast but a little over 600 miles, and the bottom must be for its whole distance strewn thickly with vegetable matter. The force of the currents is very great, sometimes as much as 75 miles a day, so that seeds, fruits, masses of vegetation harbouring small reptiles, or even large ones, as well as other terrestrial animals, need not be afloat long before they might safely be

landed on the shores of the Galapagos. Its flora, as is well known, is eminently American, while its fauna at every point discloses its affinity to the Mexican, Central or South American, and even West Indian types, from which it has probably originated; the last indicating, as well as so many of the marine types collected during this expedition, the close connection that once existed between the Panamic region and the Caribbean and Gulf of Mexico.

I have already referred to the physiognomy of the deep-sea fauna, showing relationship on the one side to Atlantic and West Indian types, and on the other to the extension of the Pacific types, which mix with the strictly deep-sea Panamic ones. The western and eastern Pacific fauna, while as a whole presenting very marked features in common, yet also present striking differences. The vast extent of territory over which some of the marine types extend, through all the tropical part of the Pacific, may readily be explained from the course of the great western equatorial current and the eastern counter current, which cannot fail to act as general distributors in space for the extension of a vast number of marine Vertebrates and Invertebrates.

Mr. Townsend made quite a large collection of birds from Chatham and Charles Islands, considering the short time we were there.

As soon as we have reached Guaymas, I shall be able to give you a better *résumé* of the character of the deep-sea fauna of the Panamic region, and of its relationship on the one side to the Pacific fauna and on the other to the West Indian region.

### III.

*Guaymas, April 25, 1891.*

We left Acapulco on April 15 for our third cruise into the Gulf of California, and steamed as far as Cape Corrientes without attempting to do any trawling. The character of the bottom, as indicated on the charts, promised nothing different from what we had dredged off Acapulco, and on the line from there to the Galapagos Islands. We made one haul off Cape Corrientes, bringing up nothing but mud and decomposed vegetable matter. This induced us to keep up the Gulf of California till we were off the Tres Marias. We there made several hauls, and obtained some *Umbellula*, *Pennatulæ*, *Trochophilum*, *Anthoptilum*, and a fine *Antipathes*, a few *Comatulæ*, a large *Astropecten*, some fine specimens of *Urechinus* and of *Schizaster*, a few *Holothurians*, *Lophothuria*, *Trochostoma*, and two species of *Elasipoda*, besides a few fragments of *Gasteropods*, with an empty shell of *Argonauta*.

Among the Crustacea there came up the usual types found living upon muddy bottom, such as *Glyphocrangon*, *Heterocarpus*, *Notostoma*, *Pentacheles*, *Nematocarcinus*, *Nephrops*, together with species of *Lithodes* and of *Munida*. The usual types of *Limicolous* Annelid also were found here, *Halinacina*, *Terebella*, *Maldania*, and the like, a few *Ophiurans*, *Ophiopholis*, and *Ophiocantha*, a few fragments of *Farrea*, and a huge *Hyalonema* of the type of *H. toxeres*. Among the Fishes there were a few *Macrurans*, *Bathypetroides*, *Lycodes*, and *Malthæ*. The trawl was usually well filled with mud, and with the mud came up the usual supply of logs, branches, twigs, and decayed vegetable matter.

On going farther north into the Gulf of California, the nature of the bottom did not change materially, and we found the trawling most difficult from the weight of the mud brought up in the trawl. But occasionally a haul was made which more than repaid us for the time spent on the less productive ones. Two of the hauls are specially worthy of mention, as being characteristic of the deep-water fauna of the Gulf of California, one made in 995 fathoms, and the other in 1588 fathoms. We obtained in these hauls a number of *Ophiomus* and *Ophioceres*, some fine specimens of *Schizaster*, a new genus allied to *Paleospeustes*, and also the same species of *Cystechinus*, with a hard test, and of *Phormosoma*, which we had obtained before on the line from the Galapagos to Acapulco. Beside these there came up a number of specimens of an interesting species of *Pourtalesia*, most closely allied to *Pourtalesia miranda*, the first type of the group dredged in the Florida Channel by Count Pourtales.

The deeper haul was specially rich in *Holothurians*, among them a fine large white *Cucumaria*, some specimens of *Trochostoma*, several species of *Bathodytes*, some of them remarkable for their white colour, their huge size, and comparatively small

number of ventral tentacles. With these were numerous specimens of an interesting species of Euphronides. In this haul I was specially struck with the Elasiopoda, and the great variety in the consistency of the skin in individuals of one and the same species; it varied in different individuals from extreme tenacity to a comparatively tough gelatine-like consistency. On carefully sifting the mud, we found a number of interesting Foraminifera, and of delicate and minute Gasteropods and Lamellibranchs, fragments of the shell of an Argonauta, and two species of a huge ribbed Dentalium. Among the Star-fishes were specially noticeable a large *Bristinga*, a long-armed *Cribrella*, and several species of *Astropecten*. The usual types of Worms were found in the mud at these greater depths. In addition to a number of *Macrurids*, we obtained a pink *Amphionus*, a large black *Beryx*-like fish, a fine *Nettastoma*, and a couple of species of *Lycodes*. The usual surface species of *Stomias* and of *Scopelus* also came up in the trawl. Among the Crustaceans were a fine lot of *Arcturus*, of *Colossendeis*, of *Glyphocrangon*, and of a *Caridid* with a deep blue patch on the base of the carapace, making the strongest possible contrast to the dark crimson colouring of the rest of the body. Blue is a very unusual colour in the deep-sea types, although the large eggs of some of the deep-sea *Macrurus* are often of a light blue tint.

We brought up in the trawl at various times, and subsequently also in the Tanner net, from depths of less than 200 fathoms, the same gigantic Ostracod which I mentioned in one of my previous letters, several specimens of *Atolla*, and fragments of a huge *Periphylla*, which must have been at least 15 inches in diameter. Also a most interesting new type of *Bougainvillia*, remarkable for having eight clusters of marginal tentacles, but only four chymiferous tubes.

We continued our experiments with the Tanner tow-net. On April 16, about 120 miles from Acapulco, we sent the net to tow at a depth of 175 fathoms, and after towing for about twenty minutes, sent the messenger to close it. On examining the bottom part of the net, which came up tightly closed, we found it to contain practically the same things as we obtained in the surface net at the same spot.

On two occasions we sent the net to be towed at depths of 800 fathoms and of 700 fathoms, the depths at these points being in one case 905 fathoms and in the other 773 fathoms. At the greater depth, the water shoaled somewhat while towing, as the closed part of the net came up partly filled with fine silt; while during the second haul, the twisting of the swivel wound the straps of the weights round the rope, and the net came up open, but must have dragged very close to the bottom, as it contained a fine specimen of *Nettastoma*, and some *Peneids*, which we supposed to be deep-sea types. Otherwise the net contained only the customary surface species of *Sagittia*, *Pteropods*, *Copepods*, *Schizopods*, *Tunicates*, and *Fishes*. These two hauls were made about the middle of the Gulf of California, at a distance of some fifty miles in a south-westerly direction from Guaymas.

On April 23, a few hours before reaching Guaymas, we made one more attempt with the Tanner tow-net, at a depth of 620 fathoms, sending the net to be towed at a depth of from 500 to 570 fathoms. We found in this case in the bottom part of the net, which came up tightly closed, a *Scopelus*, a *Peneid*, and a *Hyalea*, while the upper open part of the net contained the same surface species we had obtained before.

My experience in the Gulf of California with the Tanner self-closing net would seem to indicate that in a comparatively closed sea, at a small distance from the land, there may be a mixture of the surface species with the deep-sea bottom species, a condition of things which certainly does not exist at sea in an oceanic basin at a great distance from shore, where the surface pelagic fauna only descends to a comparatively small depth—about 200 fathoms—the limits of the depth at which light and heat produce any considerable variation in the physical condition of the water. The marked diminution in the number of species below 200 fathoms agrees fairly with the results of the *National Expedition*.

The more I see of the *Albatross* the more I become convinced that her true field is that of exploration. She is a remarkably fine sea boat, and has ample accommodation for a staff of working specialists such as would be needed on a distant expedition. The time will soon come when the Fish Commission will hardly care to continue to run her, and I can conceive of no better use for so fine a vessel than to explore a belt of 20° latitude north

and south of the equator in the Pacific, from the west coast of Central America to the East Indian Archipelago.

The success of the *Albatross* thus far has depended entirely upon the zeal, energy, intelligence, forethought, and devotion of Captain Tanner, if I may judge of the past by the present. He never spares himself, and he is always ready to make the most of the time at his disposal for the benefit of the special object he has in charge. He looks after every haul of the trawl himself, and will not allow anyone else to jeopard in any way the material of the vessel, or the time it requires to make a haul. That responsibility he assumes himself, and it constitutes his daily work. In looking over the records of the *Albatross* during her voyage from New York to San Francisco, I am struck with the amount of work which has been accomplished. It would be but a just return to Captain Tanner if Congress would make the necessary appropriations to work up and publish all that he has brought together, not only on that cruise, but also what has been left untouched thus far of the immense collections made by him in the Caribbean, and off the east coast of the United States, to say nothing of his explorations in the Gulf of California, on the coast of California, on the coast of Alaska, and in the Behring Sea, from which he has accumulated endless and most interesting material, which no other ship could get together unless she had another Tanner in command.

We reached Guaymas on April 23, in the afternoon, and I parted from the ship with great regret, but more than satisfied with the results of this expedition.

Allow me, in concluding, to thank you most cordially for having given me the opportunity to join the *Albatross* on this extended cruise, and for your kindness in urging the President to allow the vessel to be detailed for this work.

As soon as it may become practicable, I shall send you a full résumé of our work, accompanied with sketches of the Tanner tow-net and a detailed chart of the route we followed.

Very respectfully yours,

ALEXANDER AGASSIZ.

THE ORIGIN OF THE ASS, THE CAT, AND THE SHEEP IN CHINA.

AT a recent meeting of the China Branch of the Royal Asiatic Society in Shanghai, Dr. Macgowan, a well-known Chinese scholar, read a paper on the probable foreign origin of the ass, the cat, and the sheep in China. He said that the Chinese, in their numerical co-ordination of concrete and abstract nature, give the "six domestic animals" as the horse, ox, goat, pig, dog, and fowl; which seems to indicate that when that formula was framed, neither cat, sheep, nor ass had been domesticated there. When familiar beasts were selected to denote years of the duodenary cycle, to the "six domestic animals" were added the rat, tiger, hare, dragon, serpent, and monkey, to complete the dozen, as if the ass, sheep, and cat were too little known to meet the object in view, which was the employment of the most familiar representations of animated nature for the duodenary nomenclature. Still more striking is the absence of the ass, sheep, and cat from the twenty-eight zodiacal constellations, which are represented by the best-known animals.

With regard to the ass, there is ample reason to regard it as being excluded from the list of domestic animals because it was not archaic. The hybrid mule is of comparatively modern origin in China, dating back only about a score of centuries. A miscellany of the Sung era states that "the mule was not seen during the Hsai, Shang, and Chou dynasties; that it was a cross between the ass and horse from Mongolia. It is regularly bred in the north, and is worth in the market twice as much as the horse; it is popularly reported that its bones are marrowless, which is the reason of its inability to produce its kind." Again, it is recorded in a Ming cyclopaedia: "The mule is stronger than the horse, and is not a natural product of China; in the Han era it was regarded as a remarkable domestic animal." Is it likely that, if the ass existed during the three ancient dynasties, there was no crossing with the horse?

With regard to the cat, Dr. Macgowan proceeded to state that there was a quotation from a standard work which dis-

closes the fact that Yuang Chuang, the pilgrim monk, who, in the seventh century A.D., returned after sixteen years' wanderings in India, brought cats with him to protect his collection of Sanskrit Buddhist books from rats. That account, however, is somewhat invalidated by an anecdote of Confucius, who is related to have one day seen a cat chasing a rat. These conflicting statements are from authoritative sources, and it is impossible to offer a satisfactory explanation. Possibly the cat of Confucian times was only a partially domesticated wild cat. There must have been some ground for the statement of the cat having been brought from India, as it is hardly likely that in all the long period of Chinese history it should be named but twice as a domestic animal. He quotes from Chinese folk-lore on the subject of cats. As cruelty to cats and other animals is followed by retribution, so services rendered to them meet with supernatural recognition. As anciently the tiger was sacrificed to because it destroyed wild boars, so the wild cat was worshipped because it was the natural foe of rats; boars and rats being the natural enemies of husbandry. At the commencement of the Sui dynasty (A.D. 581), the cat spirit inspired greater terror than the fox did subsequently. The hallucinations of cat spirit mania prevailed, forming a remarkable episode in Chinese history, only to be likened to the fanatical delusion of witchcraft that frenzied Europe a thousand years later. It was believed that the spirit of a cat possessed the power of conjuring away property from one person to another, and inflicted through incantations bodily harm. The popular belief was intensified and spread like an epidemic, until every disastrous affair that took place was ascribed to cat spirit agency set in motion by some mischievous enemy. Accusations were lodged against suspected persons, and, the slightest evidence sufficing for conviction, the malicious were encouraged to trump up charges against the innocent, until the country became a pandemonium. No one was safe, from the Imperial family down to the humble clodhopper. Even a magnate of the reigning house, who enjoyed the titular distinction of Prince or King of Szechuan, was executed for nefariously employing the agency of cat spirits. In this manner several thousands were immolated before the delusion was dispelled. Happily the period appears to have been of brief duration: incentives such as kept up the witch mania for centuries were wanting in China. Coming down to our own times we find a cat-craft delusion prevailed over a great portion of Chékiang. "In the summer and autumn of 1847 frightful wraiths appeared throughout the departments of Hangchow, Shaohsing, Ningpo, and Taichow. They were demons and three-legged cats. On the approach of night a fetid odour was perceptible in the air, when dwellings were entered by something by which people were bewitched, causing alarm everywhere. On detecting the effluvium in the air, householders commenced gong-beating, and the sprites, frightened by the sonorous noise, quickly retreated. This lasted for several months, when the weird phenomena ceased." Well did he remember, said Dr. Macgowan, the commotion that prevailed in Ningpo throughout those months of terror. Every gong that could be procured or manufactured for the occasion was subject to vigorous thumping through the live-long night, maintained with vociferations by relays of zealous beaters. This deafening din was but a recrudescence of what had occurred a few generations before—a panic which was only exceeded by that which subsequently prevailed over the entire empire.

With regard to sheep, Dr. Macgowan said the ancient mode of writing the character for *yang*, goat, was ideographic—four strokes on the top to represent horns, two horizontal strokes representing legs, and a perpendicular one to represent body and tail. The modern form gives an additional parallel stroke, like the word for horse; it is a simple not a compound character, and when sheep came to be known, instead of making a new character, the sheep was called the "Hun-goat," thus indicating its origin and affinity. *Yang*, goat, is often translated sheep, the earliest instances being found in one of the Odes, wherein the Court habiliments of Wen Wang are called "lamb-skins and sheep-skins." This was about 1160 B.C., but it is doubtful if these robes are really the skins of sheep. It is not certain that such was the case, for the skins of goats were used then, as now, for clothes. Hun-goats are not named before the period of the Tang dynasty, say the seventh century A.D. The goat was one of the sacrificial animals, as at present, and was at the first selected for sacrifice when sheep were unknown.

In the discussion which followed, the conclusions of the paper were not accepted by all the speakers; and it was agreed that the subject was one worthy of scholarly investigation.

#### HAINAN.

THE great island of Hainan, off the south-eastern coast of China, is but little known to Europeans, although since 1877 there has been a treaty port there. Mr. Parker, the Consul at Klungchow, the port in question, lately made a short journey in the interior of the island, of which he gives some account in a recent report. He travelled about sixty miles up the Poh-Chung River, to within a mile or two of Pali-hi, which is, at most seasons of the year, considered the limit of navigation for all but the smallest craft. He walked round the walls of Ting-an city, one of the disturbed districts during the recent rebellions, on New Year's Day (February 9); they are just one mile in circuit, and differ little from those of other Chinese cities. Wherever he had an opportunity of walking diametrically across lengthy curves of the river he found the inclosed area to be extremely well cultivated; though not so flat, its general appearance recalled many features of the Tonquin delta, especially in its great wealth of bamboos. The productions of the soil are much the same, the papaw, areca-palm, sweet potato, turnip, ground-nut, orange-tree, &c.; but a peculiar Hainan feature is the cocoa-nut palm. Another peculiarity of this region is the ubiquitousness of the dwarf *Pandanus*, probably the same as the *P. odoratissima* of Fiji, the fibre of which is used in the manufacture of grass-cloth, and is usually known to foreign trade here as hemp. Much of the land was under sweet potato cultivation, and every household seemed to possess a few pigs, of the very superior and stereotyped Hainan variety, black as to the upper and white as to the lower part of the body, with a dividing line of grey running along the side from the snout to the tail. These wholesome-looking pigs are fattened on the sweet potato, and do not rely for sustenance upon precarious scavenging, as is the case with the repulsive and uncleanly animals of North China. Land contiguous to the river is irrigated by enormous wheels, forty feet in diameter, of very ingenious construction, moved by the current, needing no attention, and discharging perhaps one hundred gallons of water in a minute into the trough above, day and night without intermission. He passed several large pottery establishments; but as at the New Year all business and cultivation are suspended for a few days, the opportunity was not a very good one for gathering precise information. The temperature during the week ranged between 50° and 60° F. Game seemed plentiful everywhere, and he mentions that a German resident has recently made a very fine collection of about 400 Hainan birds, embracing 154 species, which will shortly be on their way to a Berlin Museum. One of the commonest birds in the river is a spotted white and black kingfisher of large size. Amongst the trees which attracted his attention was one locally called the "great-leaved banyan," which looks remarkably like the gutta-percha tree; the natives seem to use its gum mixed with gambier, in order to make that dye "fast"; but there is some doubt whether it is not the sap of the real banyan-tree which is used for the purpose. A very strong silk is made from the grub called the "celestial silkworm," or, locally, "paddy-insect." This grub is found on a sort of maple. When full-grown it is thrown into boiling vinegar, on which the "head" of the gut, or "silk," appears; this is sharply torn out with both hands drawn apart, and is as long as the space between them, say five feet; it is so strong that one single thread of it is sufficient to make a line with which to catch the smaller kinds of fish.

#### UNIVERSITY AND EDUCATIONAL INTELLIGENCE.

OXFORD.—The Chancellor of the University, acting as Visitor of Pembroke College, has appointed the Rev. Bartholomew Price, M.A., F.R.S., Senior Fellow, and Vicegerent of the College, Seditian Professor of Natural Philosophy, to be Master of the College in the place of the late Dr. Evans. Prof. Price, whose contributions to mathematics are well known, has long taken a leading part in University business, and his appointment to the Mastership of the College, of which he has been a Fellow since 1843, will be warmly approved.



*Postponement of Fall Term.*—A meeting of the heads of the Colleges and Halls was held under the authority of the Vice-Chancellor at the residence of the Regius Professor of Medicine, Sir Henry Acland. A report having been presented by the medical officer of health as to the great prevalence of influenza in Oxford, and the difficulty of procuring nursing and medical attendance for the patients, it was unanimously resolved to recommend the Colleges and Halls, and the delegates of the non-collegiate students, to postpone the attendance of the undergraduates to the end of the first week in February, being a fortnight later than the time originally fixed.

CAMBRIDGE.—The *University Reporter* of January 19 contains an official notification by Prof. Liveing, F.R.S., Chairman of the Council of Cavendish College, that the College ceased on January 15 to be a recognized Public Hostel of the University.

Mr. Buchanan, University Lecturer in Geography, announces for the present term a course of lectures on the development of land surfaces under climatic and other agencies.

The Special Board for Physics and Chemistry propose to establish two new special examinations for the ordinary B.A. degree, one in chemistry, including certain papers in heat, electricity, and magnetism, and another in physics, including papers in dynamics, elementary chemistry, and more advanced electricity and magnetism. The examinations will include practical work in some of these subjects.

Mr. W. N. Shaw, F.R.S., has been elected a member of this Board, and Mr. S. F. Harmer a member of the Board for Biology and Geology.

### SCIENTIFIC SERIALS.

In the *Journal of Botany* for December 1891, Mr. W. West describes a collection of Freshwater Algae from Maine, including several new species and varieties; and we have also Mr. W. Carruthers's Report of the Department of Botany in the British Museum for 1890, recording important additions to the herbarium and collections, by purchase, exchange, and gift; among the more interesting being the late Mr. J. Ralfs's type-specimens for his "British Desmidiæ."—Dr. D. H. Scott gives a detailed account of the life and writings of the late Prof. Carl v. Nägeli.

In the *Botanical Gazette* for November 1891, Mr. E. J. Hill describes the remarkable propulsive power possessed by the "sling-fruit" of *Cryptolenia canadensis*, belonging to the Umbelliferae, by which the seeds are thrown out to a distance of at least 5 feet; and Prof. Byron D. Halsted, a bacterial disease which is exceedingly destructive to the melon crops and other Cucurbitaceæ in America.—The most important article in the number for December is by Prof. Douglas H. Campbell, on the relationships of the Archeoniate, under which term he includes the Gymnosperms, as well as the Muscinæ and Vascular Cryptogams. As in previous essays, Prof. Campbell traces the phylogeny of all the higher forms of vegetable life to the Hepaticæ; both Gymnosperms and Angiosperms having probably been derived through the Ophioglossaceæ, Marattiaceæ, and Isoëtæ.—Prof. C. V. Riley describes the new insect-pest which is committing great ravages on dried plants in herbaria—the larva of *Carphoxera ptelearia*, belonging to the Geometridæ.

### SOCIETIES AND ACADEMIES.

#### LONDON.

**Zoological Society**, January 5.—Prof. A. Newton, F.R.S., Vice-President, in the chair.—The Secretary read a report on the additions that had been made to the Society's Menagerie during the months of November and December 1891. Amongst these attention was called to four Spotted-billed Pelicans (*Pelecanus manillensis*), received from Calcutta, and to a second specimen of the Formosan Fruit-Bat—a species originally described from an example received alive by the Society in 1873.—Dr. E. C. Stirling exhibited some specimens of the new Australian Marsupial (*Notoryctes typhlops*), and gave a short account of the habits of this remarkable animal, as observed in a specimen recently kept in captivity by one of his correspondents.—An extract was read from a letter received from Dr. F. A. Jentink, calling attention to the recent acquisition by one of his correspondents in Java of additional specimens of the

rare Bush-Rat (*Pithechir melanurus*).—Mr. Ernst Hartert exhibited a series of eggs of the Common and other Cuckoos, mostly collected by himself and trustworthy friends, and made remarks on the question of the similarity of the eggs of the Cuckoos to those of the owners of the nest in which they are deposited.—A communication was read from Dr. J. Anderson, F.R.S., containing notes on a small collection of Mammals, Reptiles, and Batrachians made during a recent visit to Algeria and Tunisia.—Mr. F. E. Beddard read a paper upon the Earth-worms collected by Dr. Anderson during the same expedition. Amongst them were examples of a new species of the genus *Microsolex*. A second new species of the same genus, based on examples collected by Mr. E. B. Poulton, F.R.S., in Madeira, and proposed to be called *M. poultoni*, was also described.—A communication was read from Mr. R. I. Pocock on some Myriopoda and Arachnida collected by Dr. Anderson during the same expedition.—Mr. M. F. Woodward read a paper on the milk dentition of *Procavia (Hyrax) capensis*. The author showed that Lataste's canine has a counterpart in the lower or mandibular series, and he described for the first time two small vestigial upper incisors. He concluded that the teeth named belong collectively to the first or milk set, and that the formulation of the incisors of this genus as  $\frac{1}{2}$  is probably due to the occasional persistence of the second upper milk-incisor.—Mr. Oldfield Thomas gave an account of the species of the Hyracoidea, of which order he had lately examined a large series of specimens. The author recognized fourteen species of this group of Mammals, all of which he proposed to refer to one genus (*Procavia*). Besides these, four geographical sub-species were recognized. A new species was described as *P. latastei*, from Senegal.

**Geological Society**, January 6.—Mr. W. H. Hudleston, F.R.S., Vice-President, in the chair.—The following communications were read:—On a new form of *Agelacrinites (Lepidodiscus Milleri, n. sp.)* from the Lower Carboniferous Limestone of Cumberland, by G. Sharman and E. T. Newton.—The geology of Barbados; Part II. The oceanic deposits, by A. J. Jukes-Browne and Prof. J. B. Harrison.—*Archæopneustes abruptus*, a new genus and species of Echinoïd from the oceanic series in Barbados, by J. W. Gregory. This genus belongs to a group of Echinoïda which has given some trouble to systematists, owing to the union of the characters of the orders Cassiduloidea and Spatangoidea; the other genera belonging to the group are *Asterostoma*, *Pseudasterostoma*, and *Paleopneustes*. The evidence of the new Echinoïd throws light upon the affinities of these genera. The main points suggested by a study of the new species are: (1) the abandonment of the name *Pseudasterostoma* as a synonym of *Paleopneustes*; and (2) the inclusion of the true *Asterostoma*, *Paleopneustes*, and *Archæopneustes* in the Adete Spatangoidea, whereby the Plesio-spatangidae are left as a more homogeneous family, though bereft of the chief interest assigned to it. A tabular summary of the nomenclature of the group is given. The best-known fossil species of *Asterostoma* and *Paleopneustes* occur in Cuba, in deposits referred to the Cretaceous owing to the resemblance of these Echinoïds to the common Chalk *Echinocorys scutatus*. The new genus includes a species from the same deposit, which is probably of the same age as the Bissex Hill rock from which the new species was obtained; this is at the top of the oceanic series, and belongs to the close of the great subsidence. After the reading of this paper, there was a discussion in which the Chairman, Dr. Blanford, Prof. Sollas, Prof. Harrison, Mr. J. W. Gregory, and Mr. W. Hill took part.

#### DUBLIN.

**Royal Society**, December 16, 1891.—Prof. A. C. Haddon, President of the Scientific Section, in the chair.—Mr. E. W. L. Holt read a paper on the eggs and larval and post-larval stages of Teleostean, obtained during the Society's survey of fishing grounds on the west coast of Ireland. Thirty-three species, chiefly food-fish, are dealt with. The eggs of *Gadus esmarkii*, *G. pollachius*, and *Rhombus megastoma*, are described for the first time; those of *Hippoglossa platessoides* (the long rough dab), *Scomber scomber* (the mackerel), and *Caranx trachurus* (the sea-d), are also described. The development of the long rough dab, turbot, brill, and several other species of flat-fish, is traced upwards, to the assumption of the adult characters, with more or less continuity. The paper concludes with a series of tables containing an artificial classification of the pelagic eggs of British marine Teleosteans for purposes of easy identification.

—A second paper by the same author deals with the shore and deep-sea fishes obtained during the survey, and contains descriptions and figures of some of the more interesting forms. The vertical and horizontal distribution is also discussed, and it is pointed out that the west coast of Ireland is to a great extent the meeting ground of the Scandinavian and Lusitanian or Mediterranean fish faunas. An attempt is made to give a complete list, with references, of all deep-sea fishes which have been taken in Irish waters.—A paper was then read by Dr. E. J. McWeeny, on a method of preparing Hyphomycetes, Saccharomycetes, and Schizomycetes, as museum specimens, with a demonstration of illustrative cultivations. After pointing out that our natural history collections did not, as a rule, contain specimens illustrative of these minute organisms, the author showed that the appearances presented by the aggregate masses formed by their cells could in many cases be made perfectly perceptible to the unaided eye. A collection contained in suitable vessels, comprising nearly ninety specimens, and including *Actinomyces* grown on agar, potato, and turnip, *Trichophyllum*, *Acharion*, various species of *Saccharomycetes*, *Bacillus tetani*, and many others, was then demonstrated. The specimens were prepared by Král, of Prague, and the writer hoped soon to be able to add species from Irish sources.

PARIS.

**Academy of Sciences, January 11.**—M. Duchatre in the chair.—On the resistance of coiled elastic springs to small deformations, by M. H. Resal.—On the spontaneous oxidation of humic acid and of vegetable soil, by MM. Berthelot and André. If humic acid is allowed to stand in diffused light for a short time, a change of colour occurs, and an appreciable quantity of carbon dioxide is developed. It appears from this that the brown-coloured constituents of vegetable soil furnish carbon dioxide, and tend to become discoloured under the influence of air and sunlight, by oxidizing. The action is said to be purely chemical, and not the result of the growth of microbes.—Some new observations on the estimation of sulphur in vegetable soil, and on the nature of the compounds containing it, by the same authors.—New contribution to the chemical history of the truffe; analogy between the Terfaz or Kama of Africa and Asia and the truffes of Europe, with regard to the relation between the chemical composition of soils and tubercles, by M. A. Chatin.—On the Ecuireul of Barbary, by M. A. Pomet.—On the hypergeometric series, by M. André Markoff.—On plane *riséaux* with equal invariants and asymptotic lines, by M. G. Koenigs.—On series with positive terms, by M. V. Jamet.—On the use of orthochromatic plates in astronomical photography, by MM. Fabre and Andoyer. (See Our Astronomical Column.)—On the theory of regelation, by M. H. Le Chatelier. The consequence which follows from the formula developed is that compressed pulverulent ice, in contact with a liquid or vapour less compressed, experiences an increase of solubility, fusion, or vaporization that brings about an unstable condition of supersaturation, which disappears by the crystallization of the ice in the interspaces: this solution, followed by crystallization, continues until the spaces have completely disappeared and the *nebel* has become transformed into a block of ice. The mode of hardening is thus comparable to that of cements.—On a new model of a reversible thermometer for the measurement of deep-sea temperatures, by M. V. Chabaud.—New condensation hygrometer, by Henri Gilbault. In order to determine absolute or relative humidity with a condensation hygrometer, the moment at which dew is deposited must be observed, and the temperature of the surface upon which it is formed. Many methods have been proposed to perfect the observation of the moment when the dew appears, but only a few have taken into account the equally important second condition. The author has endeavoured to improve existing methods by causing condensation to take place on a thin sheet of platinized glass, and measuring the variations of electrical resistance of the metal. He finds it possible to determine the dew-point within  $\frac{1}{10}$  of a degree by his method.—Loss of the two kinds of electricity brought about by light of high refrangibility, by M. E. Branly.—On metallic borates, M. A. Ditte.—On manganates of potash, by M. G. Rousseau. It appears from the experiments that manganese of potash, heated in the presence of a flux, gives rise to two hydrated manganates. About 600° C., the hydrate obtained is  $K_2O \cdot 16MnO_2 \cdot 6H_2O$ ; between 700° and 800°,  $K_2O \cdot 8MnO_2 \cdot 3H_2O$  is produced; and the former compound re-appears between 800° and 1000°.—On the reduction of benzine

hexachloride; condensation of benzene, by M. J. Meunier.—On the formation of dextrines, by M. P. Petit.—On a new unsaturated fatty acid of the series  $C_nH_{2n-2}O_2$ , by M. A. Arnaud.—Influence, in bare soils, of the proportions of clay and organic nitrogen on the fixation of atmospheric nitrogen, on the preservation of nitrogen, and on nitrification, by M. P. Fichard.—On the whistling language of the Canary Islands, by M. J. Lajard.—On the pelagic flora of Naalsøfjord (Faroe Isles), by M. Georges Pouchet.—On the Upper Cretaceous of the Aspe valley, its age and its relations, by M. J. Seunes.

BOOKS, PAMPHLETS, and SERIALS RECEIVED.

BOOKS.—Anthropological Religion: F. Max Müller (Longmans).—Adventures amidst the Equatorial Forests and Rivers of South America: V. Stuart (Murray).—Power and Force: J. B. Keene (Unwin).—British Flies, vol. i. Part 3: F. V. Theobald (Stock).—Methods of Gas Analysis: Dr. W. Hempel; translated by L. M. Dennis (Macmillan).—Egypt under the Pharaohs; new edition: H. Brugsch Bey (Murray).—Life in Ancient Egypt and Algeria: G. Maspero; translated by A. Morton (Chapman and Hall).—List of Snakes in the Indian Museum: W. L. Slater (Calcutta).—Manipulation of the Microscope: E. Bausch (Collins).—Magnetic Induction in Iron and Steel: Prof. Ewing (Electrician Office).—The Realm of Nature: Dr. H. R. Mill (Murray).—Annuaire de l'Académie Royale des Sciences, Belgique, 1891 (Bruxelles, Hayez).—The Optics of Photography and Photographic Lenses: J. T. Taylor (Whittaker).—New Fragments: J. Tyndall (Longmans).—The Art and Craft of Cabinet-making: D. Denning (Whittaker).—Electric-Light Cables: S. A. Russell (Whittaker).—Bergens Museums Aarsberetning for 1890 (Bergen, Gries).—Istituto Chimico Ricerche, 1890-91 (Regia Università degli Studi di Roma) (Rome).—Catalogue of Scientific Papers (1874-83), compiled by the Royal Society of London, vol. ix. (C. J. Clay).—Dynamics of Rotation: A. M. Worthington (Longmans).—Christian Doctrines and Modern Thought: Dr. T. G. B. ney (Longmans).

PAMPHLETS.—Aids to Natural Philosophy: R. S. Trivedy (Calcutta, Auddy).—The Science of Homœopathy: W. B. Picken (London).—The Glory of the Imperfect: Prof. G. H. Palmer (Boston, Heath).

SERIALS.—Journal of the Royal Agricultural Society of England, 3rd series, vol. ii., Part 4, No. 8 (Murray).—Quarterly Journal of Microscopical Science, No. 129 (Churchill).—Journal of the Royal Statistical Society, December (Stanford).—Mind, January (Williams and Norgate).—Geological Magazine, January (Kegan Paul).—Physical Society of London Proceedings, vol. xi., Part 2 (Taylor and Francis).—Ann. des k.k. Naturhistorischen Hofmuseums, Band 6, Nos. 3 and 4 (Wien, Holder).—Natura ed Arte, No. 2 (Milano).—Journal of Anatomy and Physiology, January (Williams and Norgate).—L'Anthropologie, Tome ii., No. 6 (Paris, Masson).

—Brain, Part 56 (Macmillan).—Mineralogical Magazine, December (Simpkin).—Journal of the Chemical Society, January (Gurney and Jackson).—Veröffentlichungen aus dem Königl. Museum für Völkerkunde, ii. Band, 1-2 Heft (Spemann).—Himmel und Erde, January (Berlin, Paetel).

CONTENTS.

PAGE

Parke's Personal Experiences in Equatorial Africa	265
The Austrian Economists	268
Our Book Shelf:—	
Bonvalot: "Across Thibet"	269
Wood: "Light"	269
Letters to the Editor:—	
Opportunity for a Naturalist.—Dr. P. L. Sclater, F. R. S.	269
Dwarfs and Dwarf Worship.—Harold Crichton-Browne	269
Sun-spots and Air-temperature. (With Diagrams).—A. B. M.	271
The Red Spot on Jupiter.—W. F. Denning	272
The Implications of Science.—Edward T. Dixon	272
Fresh Evidence concerning the Distribution of Arctic Plants during the Glacial Epoch. (With Map.) By Dr. A. G. Nathorst	273
Cyclones in the Arabian Sea	276
On Van der Waals's Isothermal Equation. By Prof. D. I. Korteweg	277
Notes	277
Our Astronomical Column:—	
Motion of Stars in the Line of Sight	280
Orthochromatic Plates for Astronomical Photography	281
Dredging Operations in the Eastern Pacific. By Prof. Alexander Agassiz	281
The Origin of the Ass, the Cat, and the Sheep in China. By Dr. Macgowan	285
Hainan	286
University and Educational Intelligence	286
Scientific Serials	287
Societies and Academies	287
Books, Pamphlets, and Serials Received	288

THURSDAY, JANUARY 28, 1892.

THE ASTRONOMICAL THEORY OF THE  
GLACIAL PERIOD.

*The Cause of an Ice Age.* By Sir Robert Ball, Astronomer-Royal for Ireland. Pp. 180. (London: Kegan Paul and Co., 1891.)

THIS book gives a popular account of the theory of Adhémar and Croll as to the causes of glacial periods in geological history.

The author's power as a popular expositor is well known, and this little book shows him at his best. He knows when to drive a point home, and yet is never tedious in his reiteration. But he has given here something more than a lucid explanation, for he makes a valuable contribution to the subject, and the book may be read with advantage by those who are already acquainted with the literature bearing on the theory.

The theory itself may be sketched in outline as follows:—

It is known that, under the perturbations of Venus and Jupiter, the eccentricity of the earth's orbit varies within certain limits. When the eccentricity is large, and when the precession of the equinoxes brings the perihelion to near the middle of, say, the northern winter, the annual supply of solar heat is so distributed that there will be a glacial period in the northern and a mild climate in the southern hemisphere. Two or three maxima of glaciation and mildness will usually succeed one another at intervals of 10,500 years, because the eccentricity varies with extreme slowness. When the eccentricity is small, as at present, a moderate climate will prevail in both hemispheres, whatever be the position of the perihelion.

The keynote of Sir Robert Ball's presentation of this theory is given in a short mathematical appendix. I am disposed to dissent to some extent from the manner in which this view is set forth, but the general argument will, I think, do much to convince the scientific world of the truth of the theory, even where Croll's more elaborate discussions failed to do so.

I will now give a paraphrase of the argument, and will point out where it appears to me open to objection.

The time taken by the earth to describe a degree of longitude round the sun varies as the square of its distance from the sun, and the intensity of solar radiation varies inversely as the square of the same distance. Hence the amount of heat received by the whole earth during the description of a degree of longitude is constant.

Let the year be divided into only two seasons, viz. the northern summer or southern winter when the sun is north of the line, and the northern winter or southern summer when the sun is south of the line. Also let similar days in summer and winter be defined as days on which the sun sets (say at Greenwich) as much after 6 p.m. as before 6 p.m.; similar parts of summer and winter will mean parts limited by similar days.

Now consider the solar heat incident on any specified area of one hemisphere, during any specified portion of the summer and during the similar portion of the winter. Suppose that the heat incident on the area in the portion

of summer added to that incident on it during the similar portion of winter be denoted by 2, and suppose that the excess of the heat incident in the portion of summer above that incident in the similar portion of winter be denoted by 2a; then it is clear that 1 + a is proportional to the amount of heat received by the specified area during the specified portion of its summer, and 1 - a is proportional to the amount of heat received by the area during the similar portion of winter.<sup>1</sup> Thus we may say that the contrast between the summer and winter supplies of heat (for given area and given portions of summer and winter) is represented by the fraction (1 + a) ÷ (1 - a).

This is, of course, equally true when the whole hemisphere, and the whole of summer and winter, are considered, and Sir Robert Ball shows that a is then equal to 2 sin 23° 27' ÷ π; (1 + a) ÷ (1 - a) is found to be almost exactly as 5 to 3. Using percentages he gives the ratio as 63 to 37, but the simple numbers 5 to 3 afford a closer approximation to accuracy.

It is clear that if the specified portions of summer and winter embrace the solstices, and if the specified area is tropical, a will be small, and if it is polar it will be large. The fraction (1 + a) ÷ (1 - a) continually increases as we go northward, and it may be taken as a measure of the severity of a climate. It is quite uncertain how far the climate of any one place depends on the heat supplies of the whole hemisphere on which it lies, and therefore it is uncertain how large an area and how long a season we ought to take into consideration in the present investigation. But I should have thought it legitimate, in treating of the causes of glaciation, only to consider the semi-annual heat supply of a polar cap, comprising, say, all the area north of latitude 30°; thus would have made (1 + a) ÷ (1 - a) much greater than 5 to 3. It does not seem to me, however, that we are bound to find an answer to this almost insoluble problem.

So far we have considered the supply of heat whilst the earth describes so many degrees of longitude round the sun, but climate depends on the supply of heat during a given time.

When the earth's orbit is circular, summer and winter are of equal length, and so also are similar portions of summer and winter; thus the two ways of estimating the heat supply coalesce, and the contrast between the summer and winter *daily* supplies of heat is also represented by the fraction (1 + a) ÷ (1 - a). The present condition of affairs differs but little from this standard case, and we know that the contrast between the summer and winter daily supplies of heat is such as to produce certain known climates, differing according to latitude.

<sup>1</sup> If  $\frac{1}{2}\pi \pm \phi$  be the sun's hour angle at sunset on any day in summer, and on the corresponding day in winter, and if the sun's parallax on those days be proportional to  $r \pm E$ , then it is easy to show that the amount of heat received by unit area in the course of the day is proportional to

$$(1 \pm E)^2 (\phi + \cot \phi) \pm \frac{1}{2}\pi \sin \delta \sin \lambda,$$

where  $\pm \delta$  is the sun's declination, + in summer and - in winter, and  $\lambda$  is the latitude of the place of observation.

It follows that, what is called in the text, the contrast for unit area in latitude  $\lambda$ , for this pair of days is—

$$\frac{1 + a}{1 - a} = \frac{(1 + E)^2}{(1 - E)^2}, \text{ where } a = \frac{\pi}{2(\phi + \cot \phi)}$$

The expression for the heat supply on unit area during any portion of summer or winter involves elliptic integrals, which might be given if it were worth while.

A triple integral is required to express the heat supply of any specified area during any specified portion of the year.

The question we have to ask is, If the orbit becomes eccentric, how will the contrast of daily supplies be affected?

In order to answer this, let us go at once to the extreme, when the eccentricity of orbit is a maximum. We learn that if aphelion is at midsummer, summer will be 199 days, and winter 166 days; and the converse is true when the perihelion is at midsummer.

Since 199 is to 166 nearly as 6 to 5, we see that with midsummer perihelion there are 5 days of summer to 6 of winter, and with midsummer aphelion there are 6 of summer to 5 of winter.

Hence, with midsummer perihelion, the short summer daily supply of heat may be taken as proportional to  $\frac{1}{2}(1+a)$ , and the long winter daily supply as proportional to  $\frac{1}{2}(1-a)$ . Hence the contrast between the short summer and long winter daily supplies is represented by  $\frac{6(1+a)}{5(1-a)}$ ; that is to say, the standard contrast

is augmented in the ratio of 6 to 5. Next, with midsummer aphelion, the long summer daily supply of heat may be taken as proportional to  $\frac{1}{2}(1+a)$ , and the short winter daily supply as proportional to  $\frac{1}{2}(1-a)$ . Hence the contrast between the long summer and short winter daily supplies is represented by  $\frac{5(1+a)}{6(1-a)}$ ; that is to say,

the standard contrast is diminished in the ratio of 5 to 6. In the first case, the heat supply is less evenly distributed through the year than at present, and we have a much more severe climate; in the second, it is more evenly distributed, and we have a much milder one. It follows also that, if we compare the two extreme cases together instead of both with the mean case, the change of contrast is represented by the ratio of  $6^2$  to  $5^2$ , or of 36 to 25.

I must refer the reader to the able discussion in the book of the effects which we have reason to suppose would flow from a change of contrast represented by the numbers 36 to 25; and it must suffice to say here that it seems enough to explain on the one hand the occurrence of the glaciation of England, and on the other hand the occurrence of sub-tropical plants in Greenland.

Now, the above seems to me to be substantially the argument in the book, but I dissent from the stress laid on the numerical determination of the quantity  $a$ . On p. 90 Sir Robert says:—

“This theory will be entirely misunderstood unless the facts signified by these numbers (the evaluation of  $(1+a)$  ÷  $(1-a)$ ) are borne in mind. No one can discuss the astronomical theory of the Ice Age unless the figures 63 and 37 (5 and 3 are more accurate) form a portion of his consciousness, and the refrain of his every argument.”

It may be admitted that it might have been more difficult to present the argument in a popular form without assigning a numerical value to  $a$ , but Sir Robert Ball is fully equal to such a task; and I contend that the numerical value of  $a$  is beside the mark, even if a value, appropriate to the investigation in hand, were attainable.

After presenting his own view of the question, Sir Robert Ball says (p. 134) that Croll does not seem to have been really aware of the full strength of the astronomical theory, and in this I entirely agree. Croll, in fact, rather weakens than strengthens his position when

he tries to trace in detail the action and reaction of the astronomical cause, for in doing so he is led to maintain various theses which are not susceptible of proof, and are even highly doubtful. He thus takes as the central point of his position one at which it appears to me to be weakest. In 1886 I wrote:—

“Adequate criticism of Mr. Croll’s views is a matter of great difficulty, on account of the diversity of causes which are said to co-operate in the glaciation. In the case of an effect arising from a number of causes, each of which contributes its share, it is obvious that if the amount of each cause and of each effect is largely conjectural, the uncertainty of the total result is by no means to be measured by the uncertainty of each item, but is enormously augmented. Without going far into details, it may be said that these various concurrent causes result in one fundamental proposition with regard to climate, which must be regarded as the keystone of the whole argument. That proposition amounts to this—that climate is unstable.

“Mr. Croll holds that the various causes of change of climate operate *inter se* in such a way as to augment their several efficiencies. Thus, the trade-winds are driven by the difference of temperature between the frigid and torrid zones, and if from the astronomical cause the northern hemisphere becomes cooler, the trade-winds on that hemisphere encroach on those of the other, and the part of the warm oceanic current, which formerly flowed into the cold north zone, will be diverted into the southern hemisphere.<sup>1</sup> Thus the cold of the northern hemisphere is augmented, and this in its turn displaces the trade-winds further, and this again acts on the ocean currents, and so on; and this is neither more nor less than instability.

“But, if climate be unstable, and if from some of those temporary causes, for which no reasons can as yet be assigned, there occurs a short period of cold, then surely some even infinitesimal portion of the second link in the chain of causation must exist; and this should proceed, as in the first case, to augment the departure from the original condition, and the climate must change.”

I see no reason to depart from what I said five years ago, but I now learn from this book how it is that Croll mistook the strong points of his own theory, and that a more forcible proof of it may be contained in a short work than in an elaborate volume. After expressing this opinion, it is but fair to quote and indorse the following passage (p. 112) on Croll’s famous work on “Climate and Time”:—

“I was greatly struck,” says the author, “by this work when I first read it many years ago. Subsequent acquaintance with this volume . . . has only increased my respect for the author’s scientific sagacity, and my admiration for the patience and the skill with which he has collected and marshalled the evidence for the theory that he has urged so forcibly.”

There are a few other points in the “Ice Age,” not involved in the main line of argument, on which I should like to comment.

The method adopted of stating the disturbing forces of the planets on the earth appears to me unduly sensational. We learn (p. 74) that the disturbing force of Venus is 130 million million tons, and it is impossible not to be impressed with the magnitude of the force. But if we had been told that the disturbing force on each pound of the earth’s mass was only  $1/7000$  of a grain,

<sup>1</sup> Ball (p. 234) fails to see the force of this argument.

<sup>2</sup> Brit. Assoc. Report, 1886, Address to Section A.

we should have been equally impressed with its insignificance—and yet the two statements are virtually the same. In fact, the unscientific reader is not likely to realize the prodigious number of pounds in the earth's mass.

It may be remembered that Croll computes, in "Climate and Time," the value of the eccentricity of the earth's orbit from Leverrier's formulæ, and endeavours thus to assign actual dates to various glacial periods. Now, Sir Robert Ball very justly will not admit that our knowledge of the solar system is accurate enough to justify the application of these formulæ to the enormously long intervals of time involved. I think, however, that it would have been of interest to the general reader to be told in round numbers the kind of intervals which we have reason to believe may have elapsed between one glacial period and the next; in fact, to learn whether the intervals are probably millions of millions of years, or hundreds of thousands of years. I conjecture that our knowledge of the planetary movements is sufficient to enable us to say that such an interval may be something comparable with 200,000 years. I should like, further, also to ask Sir Robert Ball whether he does not consider that Leverrier's formulæ may probably be relied on to give at least a rough approximation for about 100,000 years in the past; and, if this is so, whether we might not conclude, with fair probability, that the last glacial period occurred about that number of years ago? I must, however, disclaim any special knowledge on this point, and I should gladly see his opinion, or that of any other physical astronomer, on the matter.

In conclusion, I wish to say that, in making the foregoing criticisms and suggestions, I have no intention of disparaging the book; on the contrary, it is only because it is a good book that it is worth while to consider it carefully. I have found it profoundly interesting from end to end, and I am convinced that it will be widely read, as it deserves to be.

G. H. DARWIN.

#### POPULAR ZOOLOGY.

*Animal Sketches.* By C. Lloyd Morgan, F.G.S., Principal of University College, Bristol. (London: Edward Arnold.)

THIS is one of those delightful books of natural history for young people which their parents never had the benefit of, and for which they ought to be duly thankful. A competent naturalist here gives them the result of his full and varied knowledge, but gives it so blended with imagination and humour, so intermingled with anecdote and personal adventure or observation, as to make it a real story-book about animals, by reading which we learn much of their lives and habits, their peculiarities of structure and their relations to each other, while we seem to be only reading for amusement. There is nothing systematic in this volume. It is merely a collection of miscellaneous chapters on a variety of animals, beginning with the lion and ending with the oyster, every chapter of which is both pleasant and instructive.

The best way to notice a book of this kind is to give a few examples of the author's style, which in this case will

certainly commend the book better than any description of its contents. First, then, as a bit of serious biology, we will give a passage on the nesting-habits of the ostrich.

"The nest is scooped out in the sand, and two or three hen-birds may combine to lay their eggs in it, to the number of about twenty. It is said, and that by several observers, that, besides the eggs laid in the nest, each hen lays several in the neighbourhood, and that these are broken when the young are hatched, and the contents are given them as food. But I am inclined to regard these statements with some suspicion. The hens take turns in sitting during the day, never leaving them long in the scorching heat of the South African sun. But at sun-down the cock-bird takes charge of the eggs, and sits throughout the night. He is not going to be bound by any conventional rules as to the proper division of labour between the sexes.

"A very careful observer, Mrs. Barber, has drawn attention to the fact that the indistinct grey colours of the hen ostrich are wonderfully adapted for purposes of concealment. These birds while upon their nests do not erect their necks, but place them at full length in front of them upon the ground; and the grey-brown body might, Mrs. Barber says, be easily mistaken for some other object, such as, for instance, an ant-hill, so common on the plains of South Africa. That so large a bird should be inconspicuous may seem surprising; but another observer, Mr. W. Larden, tells us of his experience with the rhea, or South American ostrich, which seems quite to bear this out. 'One day,' he says, 'I came across a rhea in a nest that it had made in the dry weeds and grass. Its wings and feathers were loosely arranged, and looked not unlike a heap of dry grass; at any rate the bird did not attract my attention until I was close on him. The long neck was stretched out close along the ground, the crest feathers were flattened, and an appalling hiss greeted my approach. It was a pardonable mistake if for a moment I thought I had come across a huge snake, and sprang back hastily under this impression.'

"The male ostrich, with his splendid black and white feathers, would not be thus inconspicuous *by day*. But he sits at night, and his strength and pugnacity would induce most other creatures to let him alone. Mrs. Barber describes the careful manner in which the female bird approaches the nest in the morning, when her turn for incubation has come. In wide circles, and apparently in the most unconcerned manner, she will feed round the nest, never once looking towards it, but gradually approaching nearer and nearer to it by diminishing each circle as she walks round, until at length her perambulations have brought her to within a yard or so of the nest, when the birds will rapidly change places, the male walking swiftly away, and not remaining in the vicinity of the nest during the day. The wonderful rapidity with which the change is effected is perfectly astonishing, and it is impossible to see the exact manner in which it is done, so swiftly do they change places."

As an example of Mr. Lloyd Morgan's lighter manner, what can be more attractive than the opening sentences of his chapter entitled "Long-nose, Long-neck, and Stumpy"?

"And which of all the animals in the Zoo do you like best?' I said to a bright, fair-haired little girl whom I had assisted in her descent from the elephant.

"I think I like Long-nose, Long-neck, and Stumpy best, because they are so big and curious, and Long-nose best of all because he has given me a ride. Did *you* know it was his nose?"

"Of course I affected the most extreme surprise and

delight at the novel suggestion that the big, patient animal's trunk was really his nose, and said that I had always thought it was his proboscis.

"No, it isn't that, it's his nose. Auntie says so. That's Auntie over there, waiting for me. I suppose you's seen Stumpy?"

"I inquired who Stumpy was, and whether I might not know him by another name.

"I think they sometimes call him Pottums. But we call him Stumpy. Now I must go to Auntie."

And then our author tells us much about those three strange and remote types, the elephant, hippopotamus, and giraffe, in his own pleasant manner—their singular structure and habits, their external diversities concealing so much internal resemblance—devoting, however, most attention to the elephant, and correcting some exaggerated statements that have been made respecting that animal.

One of the most interesting chapters is that on snakes. It is full of information, and there is an almost fascinating account of the whole process of capturing and devouring its prey by a python, as observed at the Antwerp Zoological Gardens. Prof. Lloyd Morgan has visited, or lived in, many lands, and often enlivens his pages with personal anecdotes, of which the following is by no means the most remarkable:—

"My first experience of South African death-dealing snakes was somewhat different. One of my pupils brought me, in a large cigar-box, a 'ring-hals-slang,' a deadly and courageous snake not uncommon at the Cape, and turned him out on the verandah for our delectation. He was a spiteful little fellow, with an ominous hood, dark glossy skin, and glistening brown eye. He struck viciously at the cigar-box held up before him, indenting the wood, and moistening it with venom and saliva. I was particularly anxious to dissect out the poison-gland and examine the poison-fang of the snake, so my friend kindly presented it to me, replacing it in the cigar-box, which he tied securely. After examining the fastenings, I placed the box on the window-sill of my bedroom, which looked out into the verandah, and left it there for the night. Next morning I procured a large washing-pan, big enough to drown a small python, placed the cigar-box therein, loaded it with a couple of bricks, and poured in water to the brim. I gave the 'ring-hals' three good hours to get thoroughly drowned, removed the bricks, took out the box, gently cut the string, lifted the lid—and found that I had been drowning with the utmost care an empty cigar-box. It had been securely tied, and how a creature more than thrice the girth of my thumb had managed to escape was, and still is, a mystery to me.

"I leave the reader to imagine the detailed search of every cranny of our bedroom, on which my wife insisted. For several days every boot had to be hammered with a stick before it was put on; I stood on a chair and shook every pair of trousers, and other analogous garments, lest they should be already occupied. But no 'ring-hals' was forthcoming. And I suppose it must have been a week or so afterwards that I was summoned to the kitchen to expel an unwelcome intruder—the black cook being, so far as her skin permitted, pale with terror—which proved to be none other than the missing 'ring-hals.' I despatched him promptly, but not by drowning."

Among the specially good chapters are those on "Cousin Sarah," the chimpanzee; on the sparrow as typical of birds, under the title "Master Impertinence"; on chameleons, frogs, sticklebacks, crayfish—but it is useless to particularize when all are good. The book is well illustrated,

both with pictures and diagrams; and we may especially note that the structure of the elephant's tooth and that of the bee's compound eye are clearly elucidated by the cuts that accompany the descriptions.

Lastly, there is a pervading tone of sympathy with all that lives, as well as a general love and admiration of Nature, that renders it a most suitable work for the young. The cover and general get-up are attractive, and every school should add this charming volume to its list of prizes, with the certainty that it will be highly appreciated for its own sake by the recipients, and that its influence will be altogether wholesome and good.

A. R. W.

#### PHYSIOLOGICAL CHEMISTRY FOR MEDICAL STUDENTS.

*Outlines of Practical Physiological Chemistry.* By F. Charles Larkin, F.R.C.S., and Randle Leigh, M.B., B.Sc. Second Edition. (London: H. K. Lewis, 1891.)

THE authors state in their preface that this edition of the work is "the result of seven years' experience in teaching the subject to medical students," from which we gather that the medical student is being treated in the physiological laboratory in much the same spirit as he has long been dealt with in that of the chemist. The work before us is constructed upon an essentially similar principle to those numerous little treatises, the be-all and the end-all of which is to instruct the medical student in three months how to analyze simple salts. For such treatises, and the unifying kind of instruction to which they give rise, neither teacher nor student is to be blamed: the fault lies with the authorities who frame the medical curriculum and the syllabus for the subjects of examination. The root of the mischief lies in having to treat the medical student during his preliminary scientific training as a separate genus from the student of general science, a course which is rendered necessary through the attempt to crowd such a large number of subjects into a period of time which is wholly inadequate for the purpose; whilst another evil tending to degrade the standard of the examinations is the existence of competing corporate bodies possessing the power of granting medical qualifications. For these ills the obvious remedies are, on the one hand, extension of the minimum time occupied by the curriculum, whilst, on the other hand, a uniform standard for qualification is required for the whole of the United Kingdom: fortunately, both of these changes are already in progress. Considering the necessarily technical and empirical character of the greater part of medical education proper, it is, in our opinion, of the greatest importance that in the teaching of the pure sciences to medical students there should be as little empiricism and rule-of-thumb as possible; and it is, therefore, just in his study of chemistry that the future physician and surgeon should receive an insight into the scientific use of the understanding.

Now, it is in this respect that the work before us, which contains a large number of facts arranged in a handy form, falls short of what is required. The subject of physiological chemistry is still at best such a very empirical one, that it becomes the more necessary to give an

explanation of phenomena whenever they are properly understood. It will be urged by some that such information is out of place in a practical manual, and that it belongs to theoretical works and lectures on the subject; in our experience, however, the great difficulty in laboratory teaching is to make the student associate his practical work with what he hears in the lecture-room or reads in his study, and that it is only by continually drawing his attention to the bearing of his experiments that the latter are made to have any great educational value. In short, it is only in this way that the instruction in a chemical laboratory materially differs from that obtainable in a kitchen, and that a work on practical physiological chemistry will be raised above the level of a hand-book on cookery. By amplifying their work on the lines indicated, we believe that its value to the student would be much enhanced, for in its present form it can only be used to much purpose under the guidance of an accomplished and energetic demonstrator.

In conclusion, we must point out an error which should hardly occur in a work professing to be the result of experience, still less in a second edition. On p. 29 the student is told to prepare lactic acid as follows:—"Place 50 c.c. of milk in a warm chamber for several weeks until it becomes strongly acid. Shake the ether, and decant the ethereal extract. Evaporate the ether, add extract residue with water. It is strongly acid, and yields crystals [*sic*] of lactic acid." The passage obviously contains several printers' errors, but the crystalline nature of lactic acid is new to us.

#### OUR BOOK SHELF.

*Problems in Chemical Arithmetic.* By E. J. Cox, F.C.S. Pp. 76. (London: Percival and Co., 1891.)

THIS book contains a series of arithmetical examples chosen to meet the requirements of the examinations held by the Science and Art Department in the elementary stage of chemistry. There does not seem to be any outstanding feature to distinguish the book from others of its kind; indeed, setting aside the actual exercises, which may be useful to the teacher, the explanations of the principles involved in the calculations are, as a rule, meagre, and frequently inaccurate. Information such as the following is, to say the least of it, faulty: "Whatever may be the weight of any given volume of water, an equal volume of mercury under similar conditions will be 136 times as heavy." This conclusion was made to follow as a result of an apparently practical method of obtaining specific gravity, although no mention whatever was made of temperature or its effects in the description of the process.

The author keeps on repeating, without any qualifying clause, that the formula of a compound represents the molecule of the compound; and the student is led to infer (pp. 19 and 20) that the empirical formula as found by analysis serves to fix molecular weight. As a consequence of the above idea, several problems are set—such as, Find the molecular weight of starch, of fluor-spar, &c.—which are misleading, since they cannot be solved in practice.

The relationship between vapour-density and molecular weight is given, but the use of the former as a means of determining the latter is not even hinted at; and the author prefers to find the value of the ratio, molecular weight to vapour-density, by the use of numerical examples, rather than by a general process

of reasoning, although all the necessary points have previously been stated.

The examples include a series selected from the Department examination papers, and a table of contents and list of answers are included.

If the working of elementary problems in chemistry is to be an intellectual process, founded upon an appreciation of fact and theory, which may be supplemented but has not to be corrected by the student as he progresses, books such as the above fail to fulfil this end.

#### LETTERS TO THE EDITOR.

[The Editor does not hold himself responsible for opinions expressed by his correspondents. Neither can he undertake to return, or to correspond with the writers of, rejected manuscripts intended for this or any other part of NATURE. No notice is taken of anonymous communications.]

#### The Theory of Solutions.

IN NATURE of December 31 (p. 193) occurs a review by "J. W. R." of my book on "Solutions," which gives me occasion to enter, in a few words, upon the questions there brought forward, and to set right some errors, which have recently appeared in other places as well.

First of all I wish to express to Mr. J. W. R. my cordial thanks for the thorough and careful manner in which he has made himself acquainted with the contents of my book. I have no intention to discuss the objections made, some of which I am quite willing to recognize as well founded, but to make clear one important question in which I do not seem to be properly understood by my critic.

Mr. J. W. R. begins his discussion with the words, "To the fundamental question—"Is solution a physical or a chemical process?"—the answers are various"; and out of this variety he evidently finds against me a reproach. I have intentionally neither set up this question nor sought to answer it, for I hold it to be unclear and therefore very harmful. To the question, "Is gas-formation a chemical or a physical process?" would be answered, "In certain cases, as in the development of carbon dioxide out of champagne, a physical one; in others, as the development of carbon dioxide from limestone, a chemical one; and in many cases, as in the development of hydrogen from palladium hydride, one would be in doubt what to answer." The question set up is faulty in implicitly assuming that solution must be either a physical or a chemical process, and by this prepossession he is hindered from recognizing that I was entirely justified in placing the physical or chemical side of the question in the foreground according to the nature of the case. However, in case Mr. J. W. R. is not satisfied with this explanation, and insists upon setting up this question, I must postpone further discussion upon it until he shall have given me a sufficient definition of the ideas "physical" and "chemical" processes, and of their distinction. I know of no such definition, and have consequently not made use of the expressions.

From the definition of solution given by me, Mr. J. W. R. concludes that I am a representative of the "physical theory" of solutions, in contrast to which he places the "chemical theory." I cannot repeat energetically enough that I have never recognized such a contrast, and that I cannot at all admit the existence of such a contrast. It has never been maintained, either by me or by any other representative of the newer theory of solutions, that no interaction takes place between the solvent and the dissolved substance; on the contrary, I have for years directly encouraged research work directed towards making clear the nature of such interactions. What distinguishes the new theory of solutions, founded by van 't Hoff, from the others is that it has succeeded in discovering and bringing into connection a series of properties of solutions, which can be treated entirely independently of the question of a possible interaction between the parts of the dissolved substance and of the solvent.

All these properties hang together with the fact that in the making of a solution or in the altering its concentration there is developed or absorbed a definite amount of free or available energy, which is equal for equimolecular quantities of different substances, and is independent of the nature of the solvent. The amount of this free energy is the same as in the analogous processes with gases. These are purely experimental facts,

which, so far as I see, are not questioned by Mr. J. W. R. The newer theory of solutions, in its entirety, is only a development of the consequences of these facts; and if errors are present therein, they can only be errors in the application, since the premises are correct: for the proof of such errors we can, of course, in the interest of science, be only thankful.

It cannot possibly be used as an objection to the newer theory of solutions that it concerns itself at present with those properties of solutions which depend only so far upon the nature of the substance in question as one constant—the molecular weight—is concerned; and which properties, like the relation holding for gases between pressure, volume, and temperature, I have proposed to term *colligative* properties. For Mr. J. W. R. agrees with me that the number and variety of the conclusions which have been drawn from this fact of the existence of these properties is already very great, and it seems to be open to no doubt that the possible applications are by no means exhausted. It will certainly be the task of the future to take also into consideration those properties of solutions which depend upon the individual nature of substances; and this has, indeed, already to a certain extent been done in a particularly important case—that of the change with the solvent of the molecular weight of a dissolved substance, and especially that of the specific property of water to form electrolytic solutions. But I do not believe that we can be justly reproached for having endeavoured to first solve the relatively more simple problems before turning to the more complex ones. It will be here that what is termed by Mr. J. W. R. the “chemical theory” will take its proper place.

I beg Mr. J. W. R. to recall the history of the rivalry between these two “theories.” Van ’t Hoff and his successors developed the laws of solutions entirely without polemical strife, because, since the fundamental ideas of van ’t Hoff’s theory were entirely new, there was nothing at all in its territory to combat, as till then there was nothing there. The attacks upon van ’t Hoff’s theory were begun by an investigator who had until then directed his attention exclusively to the phenomena which I have above characterized as individual, and who was evidently unprepared to deal with such colligative properties. The defence had to consist in an unceasing clearing up of misconceptions. Now, the greatest of these misconceptions is, that both “theories” are rivals. The existence and form of the laws founded by van ’t Hoff and his successors stand at present beyond question; if the totality of these laws be termed the physical theory of solutions (which I should not do), there is nothing to be objected to this. But what has until now been known as the hydrate theory has not been in a position to give any information whatever in regard to these laws; none of them have been discovered with its aid, and since it has for its subject not the colligative but the individual properties of solutions this will not be otherwise in the future. In fact, the existence of the colligative laws, or van ’t Hoff laws, is entirely independent of whether hydrates exist in solutions or not, and all attempts, successful or otherwise, to demonstrate the existence and composition of such hydrates, lead conversely in no wise to the van ’t Hoff laws.

It will possibly not be superfluous to emphasize that with the new theory of solutions the question is not one of hypotheses, but of facts, of numerical relations. Whether one can form a conception as to the cause of the colligative laws of solutions with the aid of the kinetic molecular hypothesis or in any other way, is, for the actual existence of these laws, just as much a matter of indifference as it is for the existence of the laws of gases. In my book the question is this one of facts, and although I have therein made more use of molecular considerations than I should at present hold to be proper, yet I have done so only to render more clear the actual relations, and never to prove quantitative laws.

The theory of solutions which I represent and defend consists, accordingly, of a certain number of laws, *i.e.* of exact relations between measurable quantities belonging to solutions. I cannot see that that which as “chemical theory” is set in opposition thereto contains anything similar to this. The latter contains in actual material certain methods—very doubtful ones to my mind—for demonstrating the existence of compounds between dissolved substance and solvent. The result of these endeavours remains, however, in any event, entirely without influence upon those colligative laws. The same may be said of the future answer to the question, whether an interaction, and what, occurs between dissolved substance and solvent. In order to render this apparent, I need only recall the fact, re-

cently observed by Goldschmidt, that the depression of the freezing-point in a basic solvent, such as paratoluidine, caused by dissolving in it an acid, has practically the same value as that effected by the equal molecular quantity of an indifferent substance, although in the first case a chemical compound is formed and none in the second.

So, in the presentation of *laws* of solutions, as known up to the present, and which form the subject of my book, the so-called hydrate theory or chemical theory, did not enter into the question, because it had discovered no law of anything like general character. And further, that the methods and hypotheses of this “theory” cannot be yet looked upon as reasonably supported scientific results is known to the English-reading scientific public from a number of papers published in recent numbers of the *Philosophical Magazine*. W. OSTWALD.

Leipzig, January 4.

### A Simple Heat Engine.

AT the last *soirée* of the Royal Society, a beautiful experiment was shown by Mr. Shelford Bidwell, illustrative of the fact that nickel ceases to be magnetic at a certain definite temperature. A piece of nickel was arranged as the bob of a pendulum. As long as the nickel was below a certain temperature it was held on one side by a magnet, but when it was heated by a spirit lamp-flame beyond a certain temperature it ceased to be attracted, and passed out of the range of the flame; it then cooled, and almost instantly returned to its first position, again to be released by the heat of the flame. It occurred to me that if a disk of nickel were placed in a certain position in a magnetic field, and then heated, it would continuously revolve. This on trial I found to be the case.

The experiment was arranged thus:—The nickel disk *bc*, 5 cm. in diameter and 1 mm. thick, was mounted on an axle passing through *A*; it was held in a frame so that the faces of the two poles, *N*, *S*, of an electro-magnet were at right angles to one another; the heat was applied at *H*; the disk revolved in the

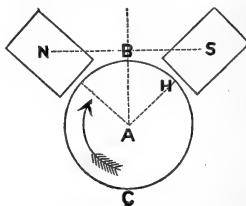

direction shown. A great many different positions were tried, but the one indicated gave far the best results. The rotation began when the part of the disk above the flame reached  $290^{\circ}$  C. The distribution of the lines of force passing through the disk from edge to edge was examined by placing a sheet of a non-magnetic metal above the disk when cold and when heated, and sifting iron filings on to it. When cold, the lines of force were uniformly disposed across it; but when the disk was heated, only a few appeared to pass through the heated region. From this it is evident that the fall on the heated side of the disk is always less than that on the side which is not so hot, and to this the rotation is due. FREDERICK J. SMITH.

Trinity College, Oxford, December 31, 1891.

### The Migration of the Lemming.

DR. ANDREW WILSON, in referring to my letter on the Norwegian lemming, is under the very natural misapprehension—which I formerly shared—that “only a miserable remnant of the original swarm” reach the sea. Now, although it is true that throughout their pilgrimage they are exposed to the attack of every rapacious bird, beast, and biped, and that even the *Rendyr*, which is by no means rapacious, never misses the opportunity of obtaining a *bonne bouche* of grass *à la saur kroust* from their paunch, yet so prolific are the lemmings at this time that their numbers increase despite their enemies; some of which, be it remembered, do not dare to follow them when they leave the *feld*. During the last great migration I noticed that the little pilgrims became much more numerous as they ad-



vanced towards the fjord; but probably no single individual of those who began the exodus lives to share its fate—only the inherited impulse survives in the offspring. These animals may live in captivity for two years; mine, at least, did so; but, so far as I know, no one else has succeeded in keeping them nearly so long; and the reasons are curious. In the first place, they fight with each other incessantly, and irrespective of sex; and secondly, they invariably defile their supply of water, so that unless this can be made *running*, they are sure to perish.

I turned out my little colony on Richmond Green, at an hour when the almost ubiquitous wye was still abed, and I watched their behaviour with a box-compass and a butterfly net. The former article proved unnecessary, as they boxed the compass for themselves, and the latter inadequate, as they ate their way through the gauze with remarkable rapidity. I should add, however, that they were all eventually recaptured, and that I derived no information as to their sense of direction from the experiment. Dr. Wilson states that naturalists generally believe that the lemmings seek a "land of promise," or rather of past fulfilment. I was under the impression that the credit (or is it the reverse?) of the idea belonged to me, but under a sun which sees so little that is new, I may well be mistaken; yet, singly or jointly, rightly or erroneously, I still believe that these migrations were formerly of benefit to the species. That they are not so now, is obvious; but the chief interest seems to lie in their periodicity, the marvellous fecundity which supports them, and the remarkable faculty which directs them.

W. DUPPA-CROUCH.

Asgard, Richmond, January 14.

P.S.—Absence from home prevented me from noticing the letter of Prof. Romanes. To the former of his two queries I reply that all the migrations which I have noticed during twenty years have crossed my lake, which lies nearly north and south, whereas had they followed the valley and watershed they would have been spared this labour and risk. The same argument applies to Lake Mjosen and others. As regards the second query, whether I believe in a sub-tropical Atlantis or not seems to me to have as little bearing on a possible land-connection between Norway and Iceland as on the Goodwin Sands. It has been suggested to me that at the close of the latest glacial epoch the lemmings may have found it necessary to migrate to the warmer western shores of the peninsula: this, however, leaves the presence of the animals in Iceland unexplained, save by the rather vague action of flotsam and jetsam. In any case, I only wish to adopt the most convenient hypothesis, until it is disproved or supplemented by a better one.—W. D.-C., January 18.

In discussing the much-debated subject of the westward migration of the Norwegian lemming, the primary cause—as it appears to me—has been altogether overlooked.

This is, that the whole of Norway north of the Jotunhjem region—that is, the whole of the country of the Norwegian lemmings—is simply the steep and narrow westward slope of a long ridge of mountains.

When Mr. Collett says that "the wanderings take place in the direction of the valleys," he simply repeats in other words the usual description of their general westerly course.

They breed in the uplands, and when very prolific the increase must descend or perish, as they consume all the vegetation of their birth-region and no further supplies of food are obtainable either northward, southward, or eastward; but downwards, *i.e.* westward, the vegetation increases steadily as they proceed, and the descending autumn snow-line pushes onward behind them. Their devastation of meadows and oat-fields proves the urgency of their downward or westward course.

There are lemmings also on the eastern slopes of the Kjolen range, *i.e.* in Sweden. We are told that the Swedish lemmings proceed to the Gulf of Bothnia and are there drowned. To do this they must travel in the eastward and southward directions of a much longer slope than the steep westward course of the Norwegian lemming. A glance at a good map of Sweden and Norway will show all this.

W. MATTIEU WILLIAMS.

The Grange, Neasden.

### The New Forest Bill, 1892.

In connection with the petitions in favour of this Bill, to which the signatures of persons interested in the New Forest

are being obtained, I am frequently asked, "What is the necessity for the Bill, and what is its object?" The facts of the case may be shortly stated as follows. The "Woods and Wastes" of the Forest comprise about 63,000 acres of land, the whole of which were, prior to 1698, open and uninclosed; but under the authority of the Acts 9 and 10 William III. c. 36 (1698) and 48 George III. c. 72 (1808), the Crown was empowered to inclose, and keep inclosed, freed and discharged from all rights of common, such quantity of land in the Forest as would amount to 6000 acres, for the growth of timber. By the Act of 14 and 15 Vict. c. 76 (the Deer Removal Act of 1851), the Crown was authorized to inclose and plant with trees any quantity of land, not exceeding 10,000 acres, in addition to the 6000 acres already in inclosure under the authority of the Acts before mentioned. The powers conferred by these Acts are not repealed by 40 and 41 Vict. c. 121 (the "New Forest Act, 1877"), but the rights of inclosure are by sec. 5 of the last cited Act limited to "such lands as are at the date of the passing of this Act inclosed, or as have, previously to such date, been inclosed by virtue of commissions issued in pursuance of the said Acts or some of them." The New Forest Act of 1877 practically secured the New Forest to the public, but the Act is virtually repealed by the 10th section of the Ranges Act, 1891 (and other Acts therein referred to), under the authority of which the War Department, with the consent of the Commissioners of Woods and Forests, can take possession of any part of the Forest for military purposes, and exclude the public from the enjoyment of any tract so taken. Already it is proposed to take 800 acres for a rifle range and the site of a camp, and there is nothing to prevent the exercise of such rights throughout the district, and the conversion of the Forest into a second Aldershot. Wherever a portion of the Forest is taken, the rights of the commoners, if they complain, will be bought up and extinguished; and thus, by taking different areas at different times, the Commissioners may before very long extinguish the common rights, and reduce the Forest into private ownership. It is clear that the proposed inclosure of 800 acres, and the user of the Forest generally in the way described, is in direct violation of the spirit and intention, as well as of the express provisions, of the New Forest Act of 1877.

The object, therefore, of the New Forest Bill is to make it clear that the Forest shall not be deemed to be within the provisions of the 10th section of the Ranges Act, 1891, and that the provisions of the New Forest Act, 1877, shall remain in force.

The rights secured by the Act of 1877 and the preservation of the Forest as an open space are of the greatest importance to naturalists, artists, and the general public, and every possible effort should be made to secure the passing of the Bill by signing petitions in support of it.

H. Goss.

Entomological Society, 11 Chandos Street,  
Cavendish Square, W., January 26.

### A Brilliant Meteor.

LAST night, at oh. 55m. G.M.T., I had the good fortune to witness the flight of a magnificently brilliant meteor. I was standing outside in the south-east re-entering corner of this building, and happened to be looking up at the constellation Leo, when the meteor suddenly flashed into sight from over the roof of the Observatory, a little east of the zenith, and not far from the stars  $\kappa$  and  $\lambda$  Ursæ Majoris, passed east of Procyon, and did not disappear till it had reached a position about 5° east of Sirius. An immediate reference to the map showed the positions of its appearance and disappearance to be about 9h. + 48° and 7h. - 15°.

For the greater part of its course it presented the appearance of a broad band of deep yellow light, but after it had passed about two-thirds of its path, it widened out into an elongated mass, distinctly rounded on the front, and of a full violet colour. From the middle of this round front the yellow band again emerged, and was finally lost to view about 15° or 20° further on. The violet mass would be about 5° in length. The whole apparition occupied 4 or 5 seconds, and the band of light was seen for an instant complete on the sky, stretching over some 65°.

About 10 minutes later a small meteor shot out from a point near the stars  $\mu$  and  $\lambda$  Ursæ Majoris, and disappeared in the direction of Procyon.

THOMAS HEATH.

Royal Observatory, Edinburgh, January 25.

## ON SOME POINTS IN ANCIENT EGYPTIAN ASTRONOMY.

## I.

1. *Direction of Preliminary Inquiry.*

I HAVE recently been prosecuting some inquiries on the orientation of Egyptian temples which have led me to the conclusion that in all probability the temples, and the gods and goddesses in the Egyptian Pantheon to which they were dedicated, were in some way connected with the sun and certain stars. The method adopted in the research has been as follows:—

(1) To tabulate the orientations of some of the chief temples described by the French Commission, Lepsius, and others.

(2) To extend and check some of these observations with special reference to my new point of view, in Egypt.

(3) To determine the declinations to which the various amplitudes correspond. In this direction I have made use of the Berlin Catalogue of star places from 1800 A.D. to 2000 B.C.,<sup>1</sup> some places for Sirius and Canopus which have been obligingly placed at my disposal by Mr. Hind, and approximate values given by the use of a precessional globe constructed for me by Mr. Newton. This globe differs considerably from that previously contrived by M. Biot, about which I was ignorant when I began the work, and enables right ascensions and declinations, but especially the latter, to be determined with a fair amount of accuracy for twenty-four equidistant points occupied by the pole of the earth round the pole of the ecliptic (assumed to be fixed) in the precessional revolution.

(4) Having the declinations of the stars thus determined for certain epochs, I have next plotted them on curves, showing the amplitude for any year up to 5000 B.C. at Thebes for a true horizon and when the horizon is raised 1° or 2° by hills or mist.

(5) In cases where the date of the foundation of a temple dedicated to a particular divinity has been thoroughly known, there was no difficulty in finding the star the declination of which at the time would give the amplitude, and, in the case of series of temples dedicated to the same divinity, an additional check was afforded if the changes of amplitude from the latest to the newest temple agreed with the changes of the declinations of the same star.

This method also enabled me to suggest that certain temples, the date of foundation of which was not known, if they formed part of the same series, would thus have the date of original foundation determined.

(6) These results led me to the conclusion that certain stars had been used for temple purposes, to the exclusion of others.

(7) The next point, therefore, was to determine why these stars had been selected, and not others: and the precessional globe was used to study these stars, in relation to their heliacal rising and setting at different times of the year, but especially at the summer solstice.

(8) The *raison d'être* of the use of these stars at once became evident in a very remarkable fashion, and indicated that observations of them might certainly have been made to herakl sunrise.

In some cases the star rose heliacally with the sun, or thereabouts; in others, it set heliacally—that is, when the sun was 10° below the eastern horizon.

2. *The Building Ceremonies recorded in the Inscriptions.*

In a paper presented to the Society of Antiquaries in May last, and elsewhere, I have given reasons to show that the temple of Amen-Râ at Karnak was built in such a manner that at sunset at the summer solstice—that is, on the longest day in the year—the sunlight entered the

temple and penetrated along the axis (more than a quarter of a mile in length) to the sanctuary. I also pointed out that a temple oriented in this manner truly to a solstice was a scientific instrument of very high precision, as by it the length of the year could be determined with the greatest possible accuracy provided only that the observations were continued through a sufficient period of time.

All the temples in Egypt, however, are not oriented in such a way that the sunlight can enter them at this or any other time of the year. They are not therefore solar temples, and they have not this use. The critical amplitude for a temple built at Thebes so that sunlight can enter it at sunrise or sunset is about 26° north and south of east and west, so that any temples facing more northerly or southerly are precluded from having the sunlight enter them at any time in the year.

Thus at Karnak, to take an instance, there are two well-marked series of temples which cannot, for the reason given, be solar, since one series faces a few degrees from the north, and the other a few degrees from the south. There are similar temples scattered all along the Nile Valley. The first question, then, to ask of the inscriptions is if there are records that these temples were directed to stars, as the solar temples were to the sun?

As a matter of fact numerous references to the ceremonial of laying the foundation-stones of temples exist, and we learn from the works of Chabas, Brugsch, Dümichen,<sup>1</sup> and others, that the foundation of an Egyptian temple was associated with a series of ceremonies which are repeatedly described with a minuteness which, as Nissen has pointed out,<sup>2</sup> is painfully wanting in the case of Greece and Rome. Amongst these ceremonies, one especially refers to the fixing of the temple-axis; it is called, technically, "the stretching of the cord," and is not only illustrated by inscriptions on the walls of the temples of Karnak, Denderah, and Edfu—to mention the best-known cases—but is referred to elsewhere.

Another part of the ceremony consisted in the king proceeding to the site where the temple was to be built, accompanied mythically by the goddess Sesheta, who is styled "the mistress of the laying of the foundation-stone."

Each was armed with a stake. The two stakes were connected by a cord. Next the cord was aligned towards the sun or star as the case might be; when the alignment was perfect the two stakes were driven into the ground by means of a wooden mallet; there was no difference of procedure in the case of temples directed to the sun. One boundary wall parallel to the main axis of the temple was built along the line marked out by this stretched cord.

If the moment of sun- or star-rise or set were chosen, as we have every reason to believe was the case, seeing that all the early observations were made on the horizon, it is obvious that the light from the body towards which the temple was thus aligned would penetrate the axis of the temple thus built from one end to the other in the original direction of the cord.

We learn from Chabas that the Egyptian word which expresses the idea of founding or laying the foundation stone of a temple is *Senti*—a word which still exists in Coptic. But in the old language another word *Put-ser*, which no longer remains in Coptic, has been traced. It has been established that *Put* means to stretch, and *Ser* means cord, so that that part of the ceremonial which consisted in stretching a cord in the direction of a star was considered of so great an importance that it gave its name to the whole ceremonial.

I will next refer to some of the inscriptions; one, dating from the last half of the third thousand B.C., occurs in

<sup>1</sup> "Baugeschichte des Dendera-Tempels." 1877.

<sup>2</sup> *Rheinisches Museum für Philologie*, 1885, p. 39.

<sup>1</sup> *Vierteljahrsschr. der Astronomischen Gesellschaft*, vol. xvi. p. 9, 1881.

the document describing the building of the temple of On (Heliopolis). We read:—"Arose the king, attired in his necklace and the feather crown; all the world followed him, and the majesty of Amenemha [first king of the XIIth dynasty]. The Kolchyt read the sacred text during the stretching of the measuring-cord and the laying of the foundation-stone on the piece of ground selected for this temple. Then withdrew His Majesty Amenemha; and King Useresen [son and co-regent] wrote it down before the people."

Nissen, from whom (*loc. cit.*) I quote the above, adds:—"On account of the stretching of the measuring cord, the Egyptian engineers were called by the Greeks ἀρμεδονιτραι, whose art Democritus boasts of having acquired."

We next turn to Abydos, possibly one of the oldest temple-fields in Egypt. There is an inscription relating to the rebuilding of one of them in the time of Seti I. (about 1445 B.C.). In this the goddess Sesheta addresses the king as follows:—"The hammer in my hand was of gold, as I struck the peg with it, and thou wast with

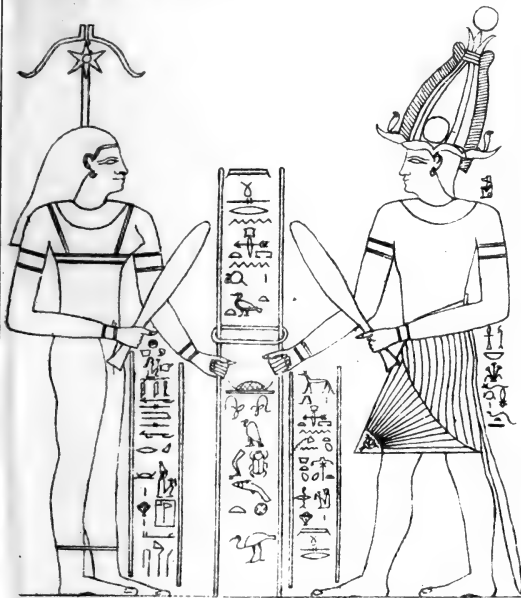

FIG. 1.—The king and the goddess Sesheta stretching the cord at the foundation of the Temple of Denderah. (From Dümichen.)

me in thy capacity of Harpedonapt. Thy hand held the spade during the fixing of its [the temple's] four corners with accuracy by the four supports of heaven." On the pictures the king appears with the Osiris crown opposite the goddess. Both hold in their right hand a club, and with it they each hammer a long peg into the ground. Round the two pegs runs a rope, tied together at the ends, which is stretched tight.

In two cases the star used for the alignment is actually named. Of these I will take, first, the record of the ceremony used in the building of the temple of Hathor at Denderah.

3. *The Alignment of the Temples of Denderah and Edfu.*

Denderah.—The inscriptions state that the king while stretching the cord had his glance directed to the *ak* of

the constellation of the *Thigh*—the old name of the constellation which we now recognize as the Great Bear, and on this line was built the new temple, "as had been done there before."

The actual inscription has been translated as follows:—"The living God, the magnificent son of Asti [a name of Thoth], nourished by the sublime goddess in the temple, the sovereign of the country, stretches the rope in joy. With his glance towards the *ak* [the middle?] of the Bull's Thigh constellation, he establishes the temple-house of the mistress of Denderah, as took place there before." At another place the king says: "Looking to the sky at the course of the rising stars, [and] recognizing the *ak* of the Bull's Thigh constellation, I establish the corners of the temple of Her Majesty."

Here, then, we have more than evidence of the stretching of a cord towards a star; an actual constellation is named, and it may be easily imagined in connection with this that many interesting questions arise of the utmost importance to the subject we are considering.

Dümichen, in his references to this passage, discuss<sup>es</sup>



FIG. 2.—The constellations of the Hippopotamus and Thigh, from the centre of the Zodiac of Denderah.

the meaning of the word *ak* in relation to some Theban grave inscriptions, in which it is suggested that *ak* is used to represent the middle course of a star, or, astronomically speaking, its culminating point as it passes the meridian. But such a meaning as this will never do in this connection; for if a cord was stretched towards a star on the meridian it would lie north and south, and therefore the temple would be built north and south. But this is by no means the orientation of the temple—a point to which I shall return presently.

But it may be suggested that the word *ak*, used in relation to the king's observation, more probably referred to the "middle point" of the constellation which would be about represented by the star *a*, which lies nearly in the centre of the modern constellation of the Great Bear, supposing, indeed, that the same stars were included in the old constellation; but on this point we certainly have

no definite knowledge, as the Thigh is so variously represented; sometimes there is a hind-quarter, represented evidently by the well-known seven stars; at others, the body of a cow (with horns and disk) is attached.

However this may be, without such a reference to some particular part of the constellation it is obvious that the stretched cord must have had a most indeterminate direction.

In order to leave no stone unturned in attempting to explain this description—supposing it to represent an undoubted fact of observation, there is another possible interpretation of the word *ak* which we may consider. The amplitude of the temple being  $73^{\circ}$  N. of E., shows conclusively that we cannot be dealing with the meridian, but may we be dealing with the most eastern elongation of the star in its journey round the Pole?

I have inquired into this matter for the time of the last building of the temple in the time of the Ptolemies, and find that the amplitude of the temple, instead of being  $73^{\circ}$ , would have been about  $70^{\circ}$ . It seems probable, then, that this interpretation will not hold, and it may be further stated that, in the case of a star at a considerable distance above the horizon, the stretching of a cord in the building ceremonial—the “*ausspannung der stricken*,” as the words *put-ser* are translated by Dümichen—would really have been no stretching of the cord at all, for the star being many degrees above the horizon, another

the wooden peg and the handle of the club; I hold the rope with Sesheta; my glance follows the course of the stars; my eye is on Masxet [that is, the ‘Bull’s Thigh constellation,’ or Great Bear]; (mine is the part of time of the number of the hour-clock); I establish the corners of thy house of God.” And in another place: “I have grasped the wooden peg; I hold the handle of the club; I grasp the cord with Sesheta; I cast my face towards the course of the rising constellations; I let my glance enter the constellation of the Great Bear (the part of my time stands in the place of his hour-clock); I establish the four corners of thy temple.” The translation is Brugsch’s. The phrases in brackets are interpreted differently by Dümichen, who translates them: “Standing as divider of time by his measuring instrument,” or “representing the divider of time (*i.e.* the god Thot) at his measuring instrument.” The word *meresch* or *merchet*, in which Brugsch suspects hour- or water-clock, does not occur elsewhere.

In this case, seeing that the temple lies with its axis very nearly north and south, as I determined by my own (magnetic) observations, the stretching of the cord was certainly in or very near the meridian; and it may be remarked that in the naos there is an opening in the roof, over the side of the second or third door from the sanctuary, and inclined at an angle of  $40^{\circ}$  (unlike any other opening that I have seen in the roof of any

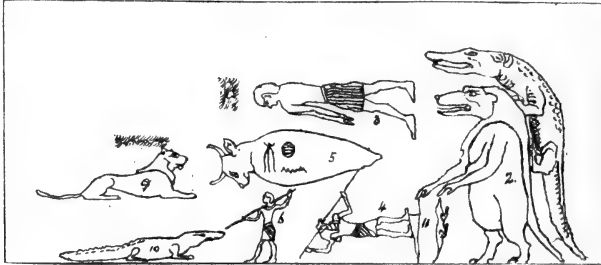

FIG. 3.—Another form of the constellation of the Thigh. (From Brugsch.)

method must have been employed, and in all probability would have been distinctly referred to in the careful statements of the ceremonies which exist.

I think, then, that we are perhaps justified in discussing this possible explanation, especially as rising stars are referred to. We now come to considerations of a different order. The inscription which we have quoted is put into the mouth of the Emperor Augustus, though he never was at Denderah.

This suggests that the temple built in the time of Augustus carried forward the account of the old foundation. There is evidence of this. The constellation of the Thigh neither rose nor set in the time of Augustus—it was circumpolar. The same statement may be made regarding the restoration in the time of Thotmes III. So we are driven to the conclusion that if we regard the inscription as true, it must refer to a time preceding the reign of Thotmes.

*Edfu*.—A reference to the same constellation (the Thigh) is also made in the account of the ceremonial used at the laying of the foundation-stone of the temple at Edfu. The king's glance was directed—in the case of the building of that temple—to the *Thigh*, but no precise reference to any star or to any point *ak* is given.

As before, I give the full translation of the inscription,<sup>1</sup> remarking that the last restoration was made B.C. 237–57. The king is represented as speaking thus: “I have grasped

Egyptian temple), which may have been used to observe the transit of some particular star. The angle I was not able to determine with absolute accuracy, as the vertical circle of the theodolite I had with me was out of adjustment.

Taking the latitude of Edfu as  $25^{\circ}$ , and assuming the angle of  $40^{\circ}$  to be not far from the truth, the North Polar distance of the star observed would be  $15^{\circ}$ .

This satisfies within a degree or so—and this is as near as we can get till more accurate observations have been made on the spot—Dubhe, the chief star in the Great Bear in the time of the Ptolemies.

I may here remark that, so far as I know, Edfu is the only temple in Egypt on the meridian. If, therefore, it were used, as on my theory all other temples were, it could only have picked up the light from each of the southerly stars, as by the precessional movements they were brought into visibility very near the southern horizon.

In this respect, then, it is truly a temple of Horus, in relation to the southern stars—the southern eyes of Horus. But it was not a sun-temple in the sense that Karnak was one; and if ceremonies were performed for which light was required, perhaps the apparatus referred to by Dupuis (vol. i. p. 450) was utilized. He mentions that in a temple at Heliopolis, whether a solar temple or not is not stated, the temple was flooded all day long with sunlight by means of a mirror. I do not know the

<sup>1</sup> Quoted from Nissen.

authorities on which Dupuis founds his statement, but I have no doubt that it is amply justified, for the reason that doubtless all the inscriptions in the deepest tombs were made by means of reflected sunlight, for in all freshly-opened tombs there are no traces whatever of any kind of combustion having taken place even in the innermost recesses. So strikingly evident is this that my friend M. Bouriant, while we were discussing this matter at Thebes, laughingly suggested the possibility that the electric light was known to the ancient Egyptians.

With a system of fixed mirrors inside the galleries, whatever their length, and a movable mirror outside to follow the course of an Egyptian sun and reflect its beams inside, it would be possible to keep up a constant illumination in any part of the galleries, however remote.

Dupuis quotes another statement that the greatest precautions were taken that the first rays of sunlight should enter a temple (of course he means a solar temple).

J. NORMAN LOCKYER.

(To be continued.)

*ON THE NUMBER OF DUST PARTICLES IN THE ATMOSPHERE OF VARIOUS PLACES IN GREAT BRITAIN AND ON THE CONTINENT, WITH REMARKS ON THE RELATION BETWEEN THE AMOUNT OF DUST AND METEOROLOGICAL PHENOMENA.—Part II.*<sup>1</sup>

THIS paper contains the results of the observations made on the dust of the atmosphere at various places in 1890. These observations were made by the author at the same stations, and about the same dates, as those made in 1889, and given in Part I. of this subject, read before the Society on February 3, 1890.

At Hyères, in 1890, the highest number of dust particles observed was 15,000 per c.c., with a wet bulb depression of 5°, the atmosphere at the time being very thick. The lowest was 725 per c.c., with a wet bulb depression of 9°·5, when the air was very clear.

At Cannes very few observations were made on this occasion. The numbers varied from 1275 to 2850 per c.c. The wind during the time was always northerly.

At Mentone the numbers varied from 26,000 per c.c. when the wind was from the town, to about 900 per c.c. when it was from the mountains, with a wet bulb depression on both occasions of 3½°; the air was clear with the lower number and thick with the higher.

At Bellagio, when the wind was southerly—that is, from the inhabited districts—the number of particles was great, on one occasion as high as 20,000 per c.c. But when the wind blew from the north—that is, from the direction of the Alps—the number fell as low as 600 per c.c. on one occasion. With the low numbers the air was clear, whereas with the high numbers there was always a good deal of haze, though the air was dry.

All the observations made at Baveno were made while the wind blew from the inhabited areas, and the air was never clear, although on some days it was very dry. The highest number observed at this station was 16,000 per c.c., and the lowest 2000 per c.c.

The observations made at the Rigi Kulm from May 15 to 20 are then discussed. There was a marked difference in the appearance of the air on this occasion compared with what was seen on the first visit. During the previous visit the weather was generally fine, and the air had that crisp clearness which gives the hard outline and crude colouring one generally associates with Swiss scenery; whereas on the second visit the air was remarkably thick and heavy.

<sup>1</sup> Abstract of a Paper read before the Royal Society of Edinburgh on January 4, by John Aitken, F.R.S. Communicated by permission of the Council of the Society.

The highest number observed on the first visit to the Rigi was not much over 2000 per c.c., while the number was as high as 10,000 on the second. The same relative condition of impurity existed at the low level also. On the first occasion the number at the level of the lake varied from 600 to 3000 per c.c., whereas on the second visit they varied from 1700 to 13,000 per c.c. Roughly speaking, there was about four times the amount of dust in 1890 there was in 1889, and the air was about four times as thick.

On the way up the Rigi the air was tested at the level of the lake and found to have about 11,000 particles per c.c. There was a very thick haze at the time, through which the mountains loomed darkly. This thickness was evidently not due to humidity, as the wet bulb showed a depression of 10 degrees. This very thick haze was therefore due to fairly dry particles of dust. On arriving at the top of the mountain in the afternoon, the air was tested and found to have slightly over 4000 particles per c.c.

During the first four days of the second visit to the Rigi Kulm the air was very thick and the number of particles great. The much greater thickness of the air on the occasion of the second visit was evidently due to dust, as the humidity on both occasions was about the same. The air on the days when the number of particles was great was very different from anything previously observed at this station. On the first visit the air was clear and bright, with only a thin haze between the observer and the distant mountains; whereas in 1890 a dense haze hung in the atmosphere, so thick that towards sunset the lower slopes of Pilatus could scarcely be distinguished. It looked as if a veil had been hung up between the observer and the distant scenery. Some time before sunset this hazy veil became coloured by the rays of the setting sun. Its upper limit was well defined in the eastern sky, at an elevation considerably above the highest of the Alps. At sunset this dusty impurity became still more apparent as the earth's shadow crept up its lower edge. Though the sky was cloudless, so dull was the setting sun, that it looked more like a harvest moon than the orb of day. So feeble were its rays after penetrating the thick haze, that they could produce no direct red light on the mountains, while much diffused light was reflected by the dust-laden air.

During this second visit there was an opportunity of testing the supposed influence of thunderstorms in depositing the dust in the atmosphere. On one of the days of this visit a violent thunderstorm raged to the east, south, and west during most of the afternoon, and in the evening it came over the Rigi Kulm. So near was the storm that the flash and crash of the thunder seemed simultaneous. The tests were therefore made in the very air in which the lightning discharges were taking place. During the day, and before the storm approached, there were nearly 4000 particles per c.c. in the air. At 6 p.m., when the storm was near, the number fell to 3000; and at 7.10 p.m., when the storm was nearly over, the number was as low as 725 per c.c. These figures seem to support the supposition that thunderstorms purify the air; and if anyone who was a believer in the purifying influence of these storms had been on the top of the mountain next day, his opinion would have been confirmed by the greatly improved appearance of the atmosphere after the storm. The thick veil which had hung in the atmosphere for at least four days was gone, and the distant mountains looked clear and distinct. Even Hochgerach, which is about 70 miles distant, was quite distinctly seen during the whole day; and the number of particles fell to 400 per c.c.

The question—Was the decrease in the dust, and the improved appearance of the atmosphere on this occasion due to the thunderstorm?—is then discussed. It is shown that this conclusion is extremely doubtful. It is

pointed out that the violent down-rush of air produced by a heavy hail-shower at the time would bring down the purer upper air to the place of observation, so that the air tested at 7.10 p.m. was not the same as that tested previously, but was air from a higher and purer stratum. The purifying influence of the down-rush of air in this case was not nearly so great as was observed in the heavy rainfall on the Eiffel Tower recorded in Part I.

By midday of the last day of the visit to the Rigi Kulm, the air again became very much hazed, and the number of particles rose to about 10,000 per c.c. On descending the mountain, the air was again tested on this day, at the level of the lake, at 3 p.m. Here the number was a little over 10,000, or very much the same as it was when tested on the way up. Its humidity was also the same, and it had the same thick appearance.

Just when on the point of finishing the tests at the level of the lake, it was observed that the numbers were becoming unsteady and were falling. The tests were therefore continued for a considerable time longer, when it was found that the dust particles, which at first were 10,250 per c.c., gradually decreased to 1700 per c.c.; a most unusual experience, and one which might have shaken our confidence in the dust-counter, had it not been noticed that this decrease in the dust was at the same time accompanied by a rise in the temperature of the air, and by a decrease in its humidity. When the tests were begun, and the number of particles was great, the temperature was 71°, and the wet bulb was depressed 11 degrees; but when the amount of dust was small, the temperature had risen to 74°·5, and the wet bulb depression was as much as 18·5 degrees. These observations all show that in a very short time there had been an entire change of the air at the place of observation. This result is shown to have been produced by the local wind, which at first blew in from the lake, changing by the upper part of the current striking the nearly perpendicular face of the mountain, curving downwards, and then blowing out towards the lake, thus bringing a purer upper air to the place of observation. After a time the down-blow ceased, and the wind at the level of the lake returned to its original direction. After the wind had blown a short time off the lake, the number of particles rapidly increased, and became slightly higher than it was at first. The temperature and humidity also returned to near their original readings.

The Rigi Kulm observations show the daily maximum of dust very clearly. On all the days, except one, the number of particles was least in the morning, and increased greatly as the day advanced, owing to the ascent of valley air on the sun-heated slopes of the mountain. The impure air had generally arrived at the mountain top before midday, and by midday the number was generally three times greater than it was in the morning.

Observations were also made on one day on Pilatus Kulm. During the whole day the mountain was covered with cloud. On this occasion the numbers were found to be very unsteady, varying greatly in short intervals. The highest reading was 1275 per c.c., and lowest 625 per c.c.

The result of an investigation into the cause of the difference observed in the air of Switzerland on the two occasions is then given. It is shown that during the days of the first visit the upper air circulation was generally from the south, and was pure, as it came from the uninhabited area of the Alps; while during the first days of the second visit the general air circulation was northerly—that is, from densely inhabited and polluted areas. While this northerly circulation continued, the air was thickly hazed, and the number of particles was great. On the morning of the day of the thunderstorm already referred to, the wind had changed and begun to blow freshly from the south, at the St. Gothard. It had also changed to south on the Säntis and Rigi. But though

the wind had begun to blow from a pure direction in the morning, it was evening before the pure air arrived at the Rigi. It was at the meeting area of the lower impure northerly air with the upper pure southerly that the thunderstorm took place. The storm began to the south, where the currents first met, and travelled northwards as the pure south wind drove the northerly air before it. The sudden drop in the number of dust particles in the storm may therefore possibly have been due to the arrival of the pure southerly air.

The day after the storm the southerly wind continued to blow, the air became very clear, and the number of particles fell practically as low as was observed on the previous visit, while the air had much the same clear appearance it had on that occasion. It would thus seem that the clearing of the atmosphere on this occasion, though at first sight it may have appeared to have been caused by the thunderstorm, was in reality caused by a change in the circulation of the air. The clearing would thus appear to have been due, not to a clearing of the dust out of the air, but to a change of the air itself.

The observations made on Ben Nevis and at Kingairloch, for July 1890, are then discussed, and a comparison made of the variations in the amount of dust at high and low levels. The observations made at Kingairloch in 1890 confirm the conclusions arrived at in Part I., that the air at this station has most dust in it when the wind blows from the east, south-east, and south—that is, from uninhabited areas—and less when the wind blows northerly—that is, from uninhabited areas. Some very remarkable exceptions to the latter conclusion were, however, observed. On a number of days when the wind was northerly the number of particles rose high at some hour of the day. On examining into the cause of the exceptional readings with northerly winds, it was found that they almost always occurred when the isobars over our area were irregular and the general circulation in a confused condition, and blowing in different directions at different stations at no great distances from each other. It is suggested that under these conditions uniformity in the air cannot be expected; that, while testing in a northerly wind, it may be southerly air that is being examined. In confirmation of this it is shown that whenever the general air circulation over our area was mixed and irregular, high numbers were also observed at some time of the day on Ben Nevis.

An examination of the numbers of dust particles shows that there was much less dust in 1890 than in 1889. The numbers in 1890 fell very low on many days, and extremely low on a few days. The lowest number observed was 16·5 per c.c. This number is much lower than any previously observed at any low-level station. Associated with the small amount of dust was an exceptionally low temperature. July of 1890 will long be remembered as one of the most inclement experienced for many years, being cold, wet, and windy.

A comparison is made of the amount of dust at Kingairloch and Ben Nevis. Although there is a considerable resemblance between the figures at the two stations, yet the likeness is not very close. This is owing to the daily maximum of dust which takes place at high levels on most days; also to the effect of the wind on the amount of dust not being the same at high and low levels; and further, the directions of the winds are not always the same at both stations. As a rule, there was much less dust at the high station than at the low one, and when the dust increased at the low station it also generally increased at the high one, and *vice versa*. These rules, however, are not without exceptions. Sometimes the lower air was purer than the upper; this happened when the wind blew from a pure direction low down, while it was from the east or south on the Ben. Mr. Rankin has shown, from an extensive series of observations at the Observatory, that the south, south-east, and east winds bring the most impure air to

the Ben—a conclusion in keeping with the result obtained at low level.

It is concluded from the observations that high winds reduce the transparency of the air. In Part I. this conclusion is indicated, and the observations of 1890 confirm it. It is pointed out that whenever the wind was high, the air was unduly thick for the number of particles and the humidity. This is thought to be due to high winds carrying large particles, and mixing the lower stratum of impure air with the purer upper air. The inequalities in the density of the different parts of the air produced by imperfect mixing will also reduce its transparency.

The Alford observations for 1890 show that the air was occasionally purer and the maximum a little higher in that year than on the previous visit. Whenever the wind blew from the south, it brought polluted air to this station, as it came from inhabited areas; and when the wind was northerly the air was pure. The number of particles was as low as 127 per c.c. with a north-west wind, while it was as high as 6800 per c.c. with a south wind.

An ascent of Callievar was made in 1890 also. On the first visit the air was clear, and the Cairngorms and Loch-nagar were clearly seen. The number of particles was 262 per c.c., and rose in the afternoon to 475 per c.c.; but on the second visit the air was thick, and only a faint outline of the Cairngorms was occasionally seen, while Loch-nagar was quite invisible. The number of particles was 710, and rose in the afternoon to 1575 per c.c.

The air on this occasion was very irregularly hazed, not being equally transparent in all directions. One mass of air darkened the view to the west, passed over the hill-top and darkened the view to the east. Before this impure mass of air arrived at the hill-top the number of particles was 710, while it was passing the number rose to 1575, and after it had gone east the number fell to 1050 per c.c. During these observations the humidity remained constant. The variations in the transparency were therefore due to variations in the amount of dust.

The condition of the air during the exceptionally warm February of 1890 was tested at Garelochhead on the 27th of the month. Previous to that date the weather had been very warm, temperatures of 50° and 60° having been frequently recorded in our area, and even 64° was observed in more places than one. The result of the tests showed the air to be remarkably full of dust. During the visit to this station in the end of January 1889, the maximum number of particles observed was 2360, and that was the only occasion on which it was over 1000; whilst on the first day of the second visit the smallest number observed was 7250, and other readings gave nearly 10,000. During this warm period the air was always impure, and had much the same appearance as it had on the 27th. The cause of this great amount of impurity was the presence of an anticyclone lying over Europe, giving rise to southerly winds over our area. The local winds were, however, very light and mixed, and there was no general circulation of the air; the dust impurities therefore accumulated, and, as the figures show, became very great. On the 28th, the day after the air was tested, a depression appeared off the north of our islands, and the isobars were closing in and westerly winds were beginning to blow. With this change the dust began to fall, and was as low as 1750 per c.c. on the 28th. On March 1 and 2 the isobars closed in still further, the winds freshened, and the dust fell to 51 per c.c., or  $\frac{1}{200}$  of what it was on February 27. During the 3rd, 4th, and 5th, the wind remained in the north-west, and the amount of dust was very small.

Certain relations between isobars and dust are pointed out. With regular isobars for westerly and northerly winds the air is pure, and the closer the isobars the purer is the air; whilst isobars for southerly or easterly winds, even though close, do not indicate pure air. From these facts it is shown that an estimate of the amount of dust on

any day can be made from an examination of the weather charts made on and previous to the day selected.

The relation between the amount of dust and the temperature is discussed, with the view of finding whether the observations made in 1890 confirm the conclusion arrived at from the previous records. That conclusion was that a great amount of dust increases the day temperature and checks the fall of temperature at night. The records of temperature and radiation made at Kingairloch in 1890 are of no value, owing to the weather being always under the influence of cyclones, so that there was an absence of clear skies, and the temperatures were regulated by what the winds brought, and were but little influenced by local conditions. But, as already stated, the dust at this station was exceedingly low in 1890, and the temperature was also exceptionally low.

The Alford observations, however, are not open to the same defect, as the weather was suitable for the purpose. These observations point to the same conclusion as that arrived at in 1889. The highest maximum temperatures were recorded on days of high dust, and the lowest minimum when the dust was at a minimum.

The observations made at Garelochhead also support the same conclusion. Towards the end of February the amount of dust was great, and from the meteorological report it will be seen that the temperature was above the mean, and was frequently very high. Again, when the westerly winds swept away the great impurity, they brought with them a high mean temperature. But after the winds ceased to blow, the pure air brought to our area by them seems to have allowed radiation to act freely, as the air then rapidly cooled, and the temperature became exceedingly low, as much as from 8 to 11 degrees below the mean in some stations in Scotland. The Ben Nevis observations show that during this exceptionally cold period the air was remarkably free from dust.

JOHN COUCH ADAMS.

IT is with deep regret that we record the death of Prof. Adams, who will always hold an eminent place in the history of astronomical science. As he is included in the list of our "Scientific Worthies," we have already given an account of his career (vol. xxiv. p. 565). It is only necessary for us now, therefore—as in the case of Sir George Airy—to note some of the leading facts of his life and work.

He was born at Lidcot, near Launceston, in Cornwall, on June 5, 1819. He received his early education at the village school and at Devonport, where he gave evidence of his remarkable faculty for mathematical and astronomical study. In October 1839, he entered at St. John's College, Cambridge; and in 1843 he graduated as Senior Wrangler and first Smith's Prizeman, becoming shortly afterwards a Fellow and tutor of his College.

Both before and after taking his degree he was fascinated by a problem which was at that time profoundly interesting to astronomers—the irregularities shown by the planet Uranus in its motion. Its orbit differed from the elliptic path which an undisturbed planet would have pursued; and as the deviations could not be explained by the influence of the other known planets, it was supposed that there must be a more remote planet which had not then been observed. To the search for this unknown planet Adams devoted all the energies of his mathematical genius, and everyone knows the brilliant success with which his labours were crowned. His solution was communicated to Prof. Challis in September 1845, and to the Astronomer-Royal in the following month. We need only refer to the facts that similar work was done in 1846 by Leverrier; that the French astronomer's results, unlike those of the English investi-

gator, were at once made known; and that on September 23, 1846, the planet Neptune was found by Dr. Galle, of Berlin, on the basis of Leverrier's elements. Adams and Leverrier rank as joint discoverers, and, as such, they received on February 11, 1848, the gold medal of the Royal Astronomical Society. Some members of Adams's college, in order to mark their sense of the importance of his achievement, raised a fund, which the University accepted, for the founding of a prize, to be called "The Adams Prize," to be awarded every two years to the author of the best essay on some subject of pure mathematics, astronomy, or other branch of natural philosophy. In 1851 he was elected President of the Royal Astronomical Society.

As he did not take orders, his Fellowship at St. John's expired in 1852, but he continued to reside in the College until 1853, when he was elected to Pembroke. In 1858 he was appointed Professor of Mathematics at the University of St. Andrews, but he held this office only during a single session. He became the Lowndean Professor of Astronomy and Geometry, at Cambridge, in 1859, in succession to the late Prof. Peacock, and retained this position during the remainder of his life.

Meanwhile, he had been carrying on many important investigations; and, until ill-health disabled him, his labours were never seriously interrupted. Foremost among his later achievements were the results of his researches on the moon and on the theory of the November meteors. In 1866 the Royal Astronomical Society awarded him its gold medal for his lunar researches. He had succeeded Prof. Challis as Director of the Cambridge Observatory in 1861, and in 1884 he served as one of the delegates for Great Britain at the International Meridian Conference at Washington.

For about a year and a half before his death, Prof. Adams was too ill to do as much work as he had been accustomed to do, and during the last ten weeks he was confined to bed. He died on the morning of January 21.

He was a Fellow of the Royal Society, and of the leading foreign scientific bodies; and honorary degrees were conferred upon him by his own University and by Oxford. The post of Astronomer-Royal was offered to him by the First Lord of the Admiralty in 1881, on Sir George Airy's retirement, but declined by him on the ground of age.

#### WALTER HOOD FITCH.

THIS talented botanical artist, whose name appears in almost every illustrated work of importance on botany or horticulture that was published in this country during the half-century from 1835 to 1885, expired at his residence at Kew on the 14th inst., after several years' indisposition, in which mental and physical decay were combined. The deceased was 75 years of age, and his whole life from early youth had been devoted to botanical drawing and painting; and his reputation was so high and so world-wide that it is unnecessary to say much on this point. Nevertheless, some particulars of the work of a man who accomplished so much and so well may be interesting to many persons who only know his work. Of Scotch birth, he was apprenticed, while still very young, to the designing department in a manufactory of fancy cotton goods at Paisley. Here his natural aptitude for drawing developed so rapidly and to such a degree as to indicate that he possessed talents of no ordinary kind, and his name soon became known outside of the factory. By some means he came under the notice of a friend of the late Sir William Hooker, and he, knowing that the latter was in need of a draughtsman, strongly recommended him to try the youth's capabilities. Sir William Hooker, at that time Regius Professor of Botany at Glasgow, acted on this suggestion, and the result was

so satisfactory that he negotiated the cancel of Fitch's indentures, took him into his sole employ, and trained him for the kind of work he wished him to execute. We have not ascertained the exact date of this event, but it must have been as early as the year 1832, for already in 1834 he was a contributor to the *Botanical Magazine*, and he continued his connection with this long-lived periodical down to 1878, having during this period drawn and lithographed some 3000 of the plates. At first his initials did not appear regularly on the plates, but, on reference to the volume for 1837, it may be seen that it was practically all his, and that he had already become an efficient botanical draughtsman. The same year (1837) the first volume of Hooker's "Icones Plantarum" was published, and although Fitch's name does not appear, we have other evidence that he was the artist. In short, he not only illustrated all the numerous works of his first patron, but also those of his son, now Sir Joseph Hooker, as well as those of numerous other public and private persons. The fertility of his pencil was equalled by its facility, grace, vigour, and boldness; and his colouring was usually rich, and full, and truthful. It is true that most of his work does not exhibit the finish and minute detail characteristic of the masterpieces of the productions of the few other botanical artists with which comparisons could be made. In 1841, Sir William Hooker was appointed Director of the Royal Gardens, Kew, Fitch accompanying him, and residing there until his death. At Kew he found full scope for his powers, and notable amongst the numerous productions of his best days are the magnificent elephant folio plates representing various stages of the development of the *Victoria regia* as cultivated at Kew and Syon House; the plates of Sir William Hooker's numerous works on ferns; of Sir Joseph Hooker's "Botany of Sir James Ross's Antarctic Voyage"; and his "Illustrations of Himalayan Plants and Himalayan Rhododendrons"; of Howard's "Quinologia"; of Bateman's "Odontoglossum"; of Welwitsch's "West African Plants"; of Speke and Grant's "Plants of the Upper Nile"; and of Seemann's "Botany of the Voyage of the *Herald*." Examples of his later work are to be found in Elwes's "Lilies," and the botany of Salvin and Godman's "Biologia Centrali-Americana," the latter the last important work he accomplished. As might be imagined from the amount of work he did, Fitch wielded the pencil with remarkable rapidity and freedom; and one could not but admire the way in which he stood up and, free handed, guided his pencil over the stone without any preliminary drawing. Botanical drawing, however, is not a very lucrative profession, and therefore not likely to attract persons of great attainments; but when Fitch became incapacitated through failing health, his merits were so far recognized as to gain him a Civil List pension, on the recommendation of the Earl of Beaconsfield, of £100 a year.

#### NOTES.

MARCH 17 is the date fixed for the Bakerian Lecture of the Royal Society, and Prof. James Thomson is to be invited to deliver it. The Croonian Lecture is to be delivered on March 24 by Prof. Angelo Mosso, of Turin, the subject being "The Temperature of the Brain."

AT the Council Meeting of the Royal Society on the 21st inst., no fewer than ten deaths were announced, seven of the deceased having been Fellows of the Royal Society, and three Foreign Members. Taking into account that the average number of deaths for the whole year is fifteen, such a list for a single month is quite extraordinary.



PHYSIOLOGICAL science has sustained a severe loss by the death of Dr. Ernst von Brücke, the well-known Professor of Physiology at the University of Vienna. He died at Vienna on January 8, in his seventy-third year. He was a pupil of Johannes Müller, and made many contributions of first-rate importance to the study of physiology.

WE regret to have to record the death of Mr. Thomas Roberts, F.G.S., of St. John's College, assistant to the Woodwardian Professor of Geology at Cambridge. He died on Saturday last at the age of thirty-five. Mr. Roberts obtained a first class in the Natural Sciences Tripos, Part I., in June 1882, and in the second part of the same Tripos for geology in June 1883. He also won the Sedgwick Prize for a geological essay in 1886. Prof. Hughes, in his annual reports to the Senate, often alluded to the value of the services rendered by Mr. Roberts to the students of his classes.

THE Sydney papers announce the death of Sir William Macleay, who did much to promote an interest in science in New South Wales. It was mainly through his efforts that the Linnean Society of New South Wales was founded; and on many occasions he acted towards it with splendid liberality. The building in which it meets was erected at Sir William's expense. This building he transferred to the Society with the lease of the land on which it stands, giving at the same time, by way of endowment, a mortgage of £14,000 bearing interest at the rate of 5 per cent. per annum. He provided an excellent reference library, and equipped the rooms with fittings, furniture, and apparatus for scientific research. According to a speech delivered by one of the presidents, and quoted by the *Sydney Morning Herald*, he also bore the greater part of the expenses of the Society's publications, supplied the salaries of its officers, and "furnished its specialists with abundant funds for their investigations and their maintenance." Besides, he was the chief instrument in obtaining the Society's Charter, and he arranged to bequeath the sum of £35,000 for the establishment of four "Linnean Fellowships" of the annual value of £400 each. In 1874, Sir William Macleay bought and fitted out the barque *Chevert* for a scientific expedition to New Guinea; and he was thus enabled to get together a very valuable collection of natural history specimens, which now form an important part of what is known as the Macleay Museum of Natural History, presented by him to the University of Sydney. In addition to his collection, which was estimated at £23,000, he gave to the University £6000 to provide for the salary of a curator.

THE facts relating to the electrical transmission of power from Lauffen, on the Neckar, to Frankfort, a distance of about 110 English miles, have now been made known. They have been established by means of elaborate tests applied by a jury of experts under Prof. Weber, of Zurich. When 113 horse-power was taken from the river, the amount received at Frankfort through the wires was about 81 horse-power, showing an efficiency, in spite of all possible sources of loss, of 72½ per cent. Prof. Silvanus Thompson, who has called attention to these striking facts, points out that it is now only a question of means whether, at the Chicago Exposition, there will be a transmission through wires of 1000 horse-power taken from the Falls of Niagara.

AN Electrical Exhibition was opened at St. Petersburg on January 23 by M. Vishnegradski, Minister of Finance, who was accompanied on the occasion by M. Durnovo, Minister of the Interior, and a number of distinguished persons. The Finance Minister, in addressing those present, traced the progress that had been made in electro-technical knowledge during the last twenty years, and dwelt upon the value of the present Exhibition for students of electricity. The Ministers and the

other personages then proceeded to visit the different sections. The Exhibition is said to be of a varied and interesting character, displaying many different kinds of machines at work.

ACCORDING to the American journal *Electricity*, the plans and specifications for the construction of the conduit system and subways in which the electric conductors, at the Chicago Exposition, are to be carried through the grounds to the different buildings have been issued by the construction department of the World's Fair. The specifications call for the completion of the work by April 15, 1892. The total length of the subway is about 4500 feet. The larger portion of the conduit will be 8 feet and 4 inches square, and will be built of the best seasoned pine. The conduit is to have two linings, the outer one consisting of 2 inch tarred plank. Between the linings will be a concrete mixture of cement, plaster, and sand.

THE *Kew Bulletin* for January opens with some most interesting notes, by Mr. J. G. Baker, F.R.S., on Agaves and Arborescent Liliaceae on the Riviera. Mr. Baker went in November last to the Riviera, chiefly for the purpose of studying these two groups of plants, which grow there in quantities in the open air. The number also contains accounts of the Cape Town Botanic Garden and the Gold Coast Botanical Station.

THE first appendix of the *Kew Bulletin* of the present year consists of a list of such hardy herbaceous annual and perennial plants, as well as of such trees and shrubs as matured seeds under cultivation in the Royal Gardens, Kew, during the year 1891. These seeds are available for exchange with colonial, Indian, and foreign Botanic Gardens, as well as with regular correspondents of Kew. The seeds can be obtained only in moderate quantity, and are not sold to the general public. No application, except from remote colonial possessions, can be received for seeds after the end of March.

THE Woolhope Club has voted £10 towards defraying the expenses connected with the course of Oxford University Extension lectures, now being delivered in Hereford by Mr. C. Carus-Wilson, on the "Outlines of Geology." It is satisfactory to note this instance of a local Club making use of the facilities offered by University Extension for giving to its younger members the opportunity of obtaining systematic training in geological knowledge. The liberal-minded action of the Woolhope Club might well be followed by other Societies throughout the country if they are satisfied of the lecturer's capacity.

WITH reference to Prof. Ray Lankester's communication on "Science in Japan" (p. 256), and especially to his remark that "English, indeed, appears to be the official language of the Imperial University, Tokyo," the following extract may be found interesting. It is taken from the preface to an English translation of a Japanese text-book of elementary geometry, based on that of the Association for the Improvement of Geometrical Teaching, and compiled by Prof. Kikuchi, of the Imperial University, for use in the ordinary normal and middle schools. "In some schools, text-books in English are in use in all the classes, in others only in the higher classes. My object in making this translation is to supply a text-book in English for use in such schools uniform with the Japanese text-book, so that the scholars may pass from one to the other without any trouble."

JUDGING by the contents of a short paper read recently before the Linnean Society, and the discussion which followed, there is an interesting field for scientific investigation amongst the ticks (*Ixodidae*) which are to be found in some parts of Jamaica and other portions of tropical America. These undesirable Acarina appear to have been introduced to Jamaica with cattle from the mainland. They are most prevalent, therefore,

in districts where cattle-rearing is the principal industry. Their maximum appearance depends very much on the season and other circumstances not yet fully worked out. In tropical countries nearly everywhere there are forms locally called ticks, but evidently allied to the harvest-bugs of Europe. These are called by the French *Rouget*, and in the West Indies *Bête rouge*. They are supposed to be larval forms of Trombidium, and are not ticks in the usual acceptance of the term. One remarkable power possessed by the *Ixodidae* is that of existing for a great length of time without food. Specimens have been known to live for years accidentally shut up in a small box. Sir Joseph Hooker, in the "Himalayan Journals," recently reprinted, states (p. 196), "that ticks were present everywhere in the hill forests"; and he remarks: "What ticks feed upon in these humid forests is a perfect mystery to me, for from 6000 to 9000 feet they literally swarmed where there was neither path nor animal life." In attacking man and animals ticks insert the proboscis deeply without pain. Buried head and shoulders, and retained by a barbed lancet, they are only to be extracted by force, which is very painful. At present very little is known of the *Ixodidae* of tropical America. It is possible there may exist numerous species, each with its own special life-history. No one appears as yet to have given undivided attention to the group, and possibly less is known of ticks from a scientific point than any other members of the West Indian fauna. In view of the influence of their occurrence on man and animals this is somewhat anomalous.

M. JEAN DYBROWSKI contributes to the current number of *La Nature* a sketch of a journey he has made from Loango to Brazzaville, and from thence to Bangui. He has collected many objects of scientific interest, including 480 ethnographic specimens, 550 botanic specimens, 280 birds, 100 mammifers, reptiles, fishes, insects, &c.

SEVERAL shocks of earthquake were felt at Rome on the evening of January 22. According to a telegram sent through Reuter's Agency, they caused such a panic in the more crowded quarters that many of the inhabitants fled from their houses, and, notwithstanding the cold weather, spent the night in the streets and public squares. The shocks were felt in the theatres, but the panic there was of short duration. The seismic disturbance had a distinct effect upon the clocks, some stopping at 11.25, and others at 11.27. Several of the lamps in the streets were extinguished. The shocks were noticed by the Pope, who sent to the Vatican Observatory to make inquiries. They were very generally felt throughout the province of Rome. At Genzano a few houses fell in, but no one was injured. At Civita Lavinia an old tower, dating from the Middle Ages, fell and buried two persons, who were, however, promptly extricated. Several houses are in a dangerous state. A severe shock was also experienced at Velletri, but the damage done was insignificant.

ACCORDING to the Paris correspondent of the *Daily News*, two slight earthquake shocks were felt on Sunday, January 24, at Le Mans, the centre of an important agricultural district in the west of France. At Sarce, about 2 a.m., the villagers were awakened by a rather severe shock which caused the school bell to ring. At Château du Loir, a town on the State railway line from Paris to Bordeaux, the first shock lasted three seconds, and awakened everybody. The second took place at half-past three, and was slight.

THE U.S. *Monthly Weather Review* for October 1891, contains a continuation of curves previously published, showing the fluctuations of temperature and pressure at the base and summit of Mount Washington (altitude 6279 feet), and completes them for the months January to March from 1871-86, or for 16 years, with a short discussion by Prof. H. A. Hazen. The base curves show many minor fluctuations of temperature not to be

found in the summit curves, most of which are probably due to diurnal range, but as regards the larger fluctuations the most marked characteristic in the temperature curves has been their closeness at base and summit. The earlier change at the summit in both cold and hot waves is remarkable. The fluctuations of pressure are almost identical at the base and summit. Occasionally, the change in temperature at the summit has preceded that in pressure to such an extent as to cause the phases of the latter to lag behind. The curves have been published in the hope that meteorologists will make a special study of them.

It is a well-known fact that, with the same temperature by the thermometer, one may have, at different times, a very different feeling of heat or cold. This varies with the temperature of the skin, which is chiefly influenced (according to M. Vincent, of Uccle Observatory, Belgium), by four things: air-temperature, air-moisture, solar radiation, and force of wind. M. Vincent recently made a large number of observations of skin-temperature in the ball of the left hand, and constructed a formula by means of which the skin-temperature may be approximately deduced from those four elements. He experimented by keeping three of the four constant, while the fourth was varied, and a relation could thus be determined between the latter and skin-temperature. One fact which soon appeared was, that the relative moisture of the air has but little influence on skin-temperature. It was also found that for every 1° C. of the actinometric difference (excess of black bulb thermometer) the skin-temperature rises about 0°·2; and with small wind-velocities, every metre per second depresses the skin-temperature about 1°·2. In testing his formula, M. Vincent found, with cold or very cold sensation, considerably greater differences between the calculated and observed values than in other cases. This he attributes to the great cooling of the relatively small mass of the hand. Taking the cheek or eyelid, the results were better. He constructs a scale of sensations corresponding to different skin-temperatures as he found them (which scale would, of course, vary somewhat with individuals).

LAST winter, in December and January, M. Chaix made a number of observations of the temperature of the air, the snow, and the ground, at Geneva; of which he has given an account to the Physical Society there. He observed the air at four different heights; granular, pulverulent, and bedded snow, on the surface and at different depths; and the surface of bare ground as well as of ground covered with snow. There was no difference in mean temperature between the air at 1 and at 2 metres; and very little between the former and that on the snow surface. The surface of the ground was 4°·265 C. warmer than the surface of the snow (0·13 m. above), through arrest of radiation. But the bare ground was not cooled so much as the snow surface, and it was only 2°·04 colder than the snow-clad ground. This shows the frigorific influence of snow on climate. Air passing over bare ground would have been 2° warmer than if it passed over the snow. The snow surface was sometimes warmer, sometimes colder, than the air 1 or 2 m. above. In the dry winters of Siberia and Sweden, the snow-surface is generally (according to Woeikof) much colder than the air. M. Chaix explains the variations observed at Geneva by fluctuations in the relative humidity, involving alternate vaporization and condensation at the snow surface. In two-thirds of the cases, indeed, abnormal cooling of the snow corresponded with a low humidity, and heating with a high humidity, and often formation of hoar frost at the surface.

AN interesting paper on Prof. Wiburgh's air-pyrometers was read by Mr. John Crum before the Institution of Engineers and Shipbuilders in Scotland on December 22 last, and is now printed in the Institution's Transactions. Beginning at the beginning, Mr. Crum explained that a pyrometer is an instru-

ment used in the measurement of high temperatures. In constructing his pyrometers, Prof. Wiborgh followed two principles—first, that a certain quantity of air, when heated, is maintained at the same volume, and the increase of pressure gives a measure of the increased temperature; and second, that the air is maintained unaltered in pressure when the temperature is determined by the change of volume. The two forms of his air-pyrometers may be compared to the two forms of the barometer—the mercurial and the aneroid. The air-pyrometer in its aneroid or metallic form is especially adapted to determine the temperature of the hot blast, the gases from all sorts of furnaces, of distillation-products from retorts, &c.; and generally it will fulfil any demands that may fairly be made upon an accurate instrument for ascertaining temperatures for practical purposes, in cases where the temperature to be determined ranges from 0° to 1400° C.

A REMARKABLE illustration of the height of breaking waves is afforded by the following paragraph, which we take from the *San Francisco Chronicle* of January 6:—"Portland, January 5. The lighthouse tender *Manzanita* reached Tillamook Rock Sunday for the first time in six weeks, and brought away the keeper, George Hunt, who has been on the rock for four years, and has been transferred to the Cape Mars Light. He says, in the storm of December 7 the waves swept clear over the house, washing away their boats, and tearing loose and carrying away the landing platform and tramway, which were bolted to the rock. On the 29th the waves were still higher, and streams of water poured into the lantern through the ventilators in the balloon top of the dome, 157 feet above the sea-level. The lighthouse was shaken to its foundation by the impact of seas against it, and the water found its way into the house. Men were on duty all night to keep the lamp burning, and but for the wire screen the shutters of the lantern would have been demolished. All hands were alarmed, and old sailors of the crew say they would sooner have taken their chances on board a ship." Prof. Edward S. Holden informs us that it is known to him personally that this lighthouse is sometimes buried in spray and water, and that the glass of its lanterns has been broken by the impact.

THE U.S. National Museum prints a capital paper, by Mr. Frederic A. Lucas, on animals recently extinct or threatened with extermination, as represented in the Museum's collections. In each case the cause of destruction is noted. Mr. Lucas finds that in nearly every instance the cause is "reckless slaughter by man." As an instance of the way in which animals may be destroyed, he refers in the introduction to peccaries. In 1885 these little animals were so abundant in several counties of Texas that their well-worn tails were everywhere to be seen, while their favourite haunts could be readily picked out by the peculiar musky odour characteristic of the creatures. Shortly after that date, hog-skin goods being in favour, a price of fifty cents each was offered for peccary hides, with the result that by 1890 the peccaries were practically exterminated.

THE fresh-water sponges in the collection of the late Mr. Henry Mills were placed some time ago in the hands of Dr. D. S. Kellicott, on the understanding that a representative set of specimens would be selected and prepared for the Buffalo Society of Natural Sciences. Dr. Kellicott has now finished his labours, and submitted the specimens to the Society. He is of opinion that the region about Buffalo Bay and the Niagara River affords almost ideal conditions for the life and growth of fresh-water animals. Its richness, he thinks, is even yet scarcely appreciated. The outlet of the American fresh-water ocean remains at almost a constant level. It is not, like so many lesser American rivers, a mere thread of heated water in summer and a flood of tilt in winter and spring. Neither

storm nor season greatly disturbs its clearness or destroys its purity; and owing to its mass its temperature changes slowly and the range is moderate. There are also deep passages, once portions of the river-bed, now almost land-locked, but still sufficiently open to the river to admit fresh water and maintain a constant level. Aquatic life in these channels is remarkably luxuriant for a North American station in latitude 43°. Again, there are small rivers or creeks entering the main river, the estuaries of which are deep, quiet, and supplied from above with swamp and land drainage, whilst their constancy is assured by that of the Niagara. These are teeming with a vast variety of microscopic plants and animals from early summer to December. These conditions are especially favourable to the growth of sponges, and they are found in extraordinary abundance. Whilst the number of species recorded compares favourably with any explored locality in the world, the abundance of representatives is, according to Dr. Kellicott's experience and the testimony of others, quite unsurpassed.

THE working of mercury mines appears to have become an industry of some importance in Russia. According to the *Journal de St. Pétersbourg*, quoted by the *Board of Trade Journal*, there have been found in the district of Bakhmont (province of Catherinoslaw) rich deposits of mercury ore, and the works which have been established there, increasing their operations year by year, have succeeded in producing at the present time 20,000 pounds of mercury annually (pound = 36 pounds avoirdupois). Other deposits of mercury have been discovered in Caucasia, in the province of Daghestan; and the Mining Administration has every reason to believe that private enterprises will be established which will make undertakings of this kind very profitable. Mercury is, as is known, very rare. It is only found in more or less considerable quantity in Spain, Austria, the United States of America, and Italy. The works in the province of Catherinoslaw extract 20,000 pounds of pure mercury from more than 3,500,000 pounds of ore (sulphate of mercury). This quantity is sufficient for Russian consumption, and even allows of an export of 14,000 pounds to other countries.

SOME time ago the Minister of Agriculture in Victoria, acting on the advice of the Board of Viticulture, authorized, among other reserves throughout the colony, the reservation of about 1100 acres in the Donully district as a viticultural reserve for experimental purposes. From this area a space of twenty acres has been excised, which has now been cleared and fenced with vermin-proof wire, for the purpose of establishing a perfume farm and experimental plot, for the growing of perfume plants, medicinal drugs, and the production of essential oils. A list of the plants under cultivation at the farm, with a report of the progress up to date, is included in a hand-book issued by the Victorian Royal Commission on Vegetable Products; and it is anticipated that satisfactory results will follow during the present season. The hand-book is published in order that all who may choose to avail themselves of the opportunity may make experiment in their several localities, with the view of comparison with the plot established at Donully for educational purposes, and so that an interesting and profitable industry may be established in the colony.

FROM a series of experiments made a short time ago (*Naturw. Rdsch.*), Prof. Wesendonck, of Berlin, inferred that dustless air, in friction with metals, does not generate electricity. But carbonic acid, under like conditions, readily gave a charge, and this was thought to be due to cloud-formation in the gas streaming out of the vessel which had held it in liquid form, the small water-particles charging the metal by friction. Further experiment has seemed to confirm this view. The gas let out from such a vessel, in vertical position, with some freedom, appears cloudy. Gaseous carbonic acid, under 50 or 60 atmospheres,

at ordinary room temperature, must be allowed to issue in a stronger current from the containing bomb to obtain this cloudy look. If a brass spiral is attached to the mouth of the bomb, the cloud-formation is made very difficult; and if the spiral is then strongly cooled, the cloud reappears. With the spiral in boiling water, no cloud is formed, however free the stream of gas. This behaviour quite corresponded to the electrical effects. Even a weak stream of gas from the vessel of liquid carbonic acid gave a well-marked charge; a less effect was had with the bomb of compressed gas; still less when the spiral was added; and least of all with the spiral in hot water, however violent the stream of gas. Prof. Wesendonck concludes that gaseous carbonic acid is not capable of generating electricity by mechanic friction on metal.

HERR ÅNGSTRÖM has been lately engaged in examining with a bolometer the heat radiation of various rarefied gases under the electric discharge. He confined himself to the stronger positive light, using cylindrical glass tubes, with lateral electrodes, and rock salt plates at the ends. An accumulator of 800 Planté elements was the source of electricity. Briefly stated, the results are these:—With a given pressure the radiation is proportional to the intensity of the current. With constant current, the radiation does not vary while the pressure varies between 0.1 and 1.5 mm., but at higher pressures it increases somewhat. With the same gas and pressure, the composition of the radiation is constant, and does not depend on the intensity of the current. With varying density of gas, the ratio of the intensity of radiation of shorter wave-lengths to that of the whole decreases with increase of pressure. (This ratio varied, *e.g.*, from 46 to 15 per cent. in carbonic oxide between the above pressure limits.) Thus this ratio, at low pressures, reaches much higher values than in our ordinary light sources. The intensity of total radiation varies considerably in different gases, and stands in no simple relation to the molecular weight, nor to difference of potential in the gas; nor does it seem to depend on absorption of gas at ordinary pressure and temperature.

DR. SYMES THOMPSON will deliver Gresham Lectures, on the nerves, on February 2, 3, 4, and 5. They will begin each evening at six o'clock, and will be free to the public.

PROF. H. G. SEELEY, F.R.S., will deliver a course of four lectures at Gresham College, in connection with the London Geological Field Class on the four Saturday afternoons in February. The subject will be: "The Physical Geography of the London District in relation to its Geological Structure." Particulars may be had of the Hon. Sec., Mr. J. Herbert Hodd, 78 Queen's Road, Finsbury Park.

THE third series of lectures given by the Sunday Lecture Society begins on Sunday afternoon, January 31, in St. George's Hall, Langham Place, at 4 p.m., when a lecture will be delivered by Mr. Sergius Stepiak. Lectures will subsequently be given by Dr. Andrew Wilson, Mr. George Wotherspoon, Mrs. Proctor (widow of the late Richard A. Proctor), Mr. Frank Kerslake, Miss Amelia B. Edwards, and Dr. E. E. Klein, F.R.S.

THE following gentlemen have arranged to give lectures at the Royal Victoria Hall during February: on the 2nd, Dr. James Edmunds on "An Emigrant in North-West Canada"; 9th, Prof. Oliver on "The Habits of Plants"; 16th, Prof. Carlton Lambert on "Gas, Paraffine, and Electricity" (with experiments); 23rd, Mr. J. W. Gregory on "Waterfalls."

AT the last meeting of the Chemical Society, on January 21, Prof. Smithells gave a preliminary account of some novel experiments on "The Origin of Flame Coloration." At a previous meeting he described a method of widely separating the two cones of combustion which constitute the flame of a bunsen burner (see NATURE, vol. xlv. p. 214). Trying the effect of intro-

ducing metallic salts into the two cones separately, he has found that in most cases no marked differences of coloration are produced. But in the case of copper salts the inner cone assumes merely a general yellowish luminosity, whilst the outer cone is brilliantly tinged with the green colour commonly ascribed to the vapour of copper or copper salts. Of the two cones the inner one is by far the hotter. The chief difference between them, apart from this, is that the inner one is surrounded by an atmosphere containing carbon dioxide, carbon monoxide, water, and hydrogen, but no uncombined oxygen, whereas the outer one is bounded by atmospheric air. The only explanation of the phenomenon that has yet offered itself is that the production of the green colour is connected with the act of oxidation. Further support is lent to this view by the fact that if copper oxide dust be introduced into the inner cone, a general luminosity devoid of green is produced, but at the same time the outer cone is coloured green. It would appear as if the copper oxide were reduced to metal in the inner cone, and simply glowed as a solid body, the copper being thereupon re-oxidized in the upper flames in contact with the air. The hypothesis is therefore tentatively put forward that some flame colorations at any rate are due to ether disturbances accompanying the act of chemical combination, and are not to be ascribed to the mere incandescence of single substances. Further experiments made with the apparatus are conformable to this view, but Prof. Smithells has commenced a spectroscopic study of the subject, and has in view the prosecution of independent methods of inquiry. Understanding that the flame-dividing apparatus is likely to come into general use, he has been led to give this preliminary account of the experiments.

A NEW liquid compound of carbon, oxygen, and chlorine was described by M. Troost on behalf of M. Fauconnier at the last meeting of the Académie des Sciences. It may be considered

as oxalyl chloride,  $\begin{matrix} \text{COCl} \\ | \\ \text{COCl} \end{matrix}$ , the dichlorine derivative of oxalic acid, and has been prepared by M. Fauconnier by the action of phosphorus pentachloride upon ethyl oxalate. Prof. von Richter has previously shown that when these two substances are allowed to react upon each other, a compound of the composition

$\begin{matrix} \text{COCl} \\ | \\ \text{COOC}_2\text{H}_5 \end{matrix}$  is formed. This substance, which has been

termed chloroxalic ether, is a fuming liquid possessing a pungent odour, and boiling at  $131^{\circ}5$ . The new compound is produced by varying the conditions of Prof. Richter's experiment in the following manner. A mixture of phosphorus pentachloride and ethyl oxalate, in the proportion of two molecules of the former to one of the latter, is heated by means of an oil-bath in a flask fitted with a Le Bel-Henninger fractional distillation apparatus and condenser. When the temperature of the bath reaches  $125^{\circ}$ , a lively reaction commences, accompanied by evolution of ethyl chloride vapour and hydrochloric acid. When the temperature is slowly raised to  $150^{\circ}$ – $155^{\circ}$ , a liquid mixture distils over, consisting of oxalyl dichloride, phosphorus oxychloride, and ethyl chloride. When this mixture is subjected to repeated fractional distillation, the oxalyl dichloride is eventually isolated as a mobile, strongly-fuming liquid boiling at  $70^{\circ}$ . It is endowed with an odour more irritating even than those of the chlorides and oxychloride of phosphorus, and which reminds one somewhat of carbonyl chloride,  $\text{COCl}_2$ . It reacts violently with water, forming oxalic and hydrochloric acids. With anhydrous alcohols it reacts in an extremely energetic manner. Thus with methyl alcohol it forms methyl oxalate, which may be obtained crystallized from the solution, and hydrochloric acid is evolved, great rise of temperature being manifested during the reaction. The formation of this second oxychloride of carbon is of considerable interest, as emphasizing once more the disap-

pearance of the line of demarcation between organic and inorganic compounds; for here we derive what may truly be considered as an inorganic compound from a substance so purely organic as an ethereal salt.

In our chemical note of last week the experiments of Dr. Merz upon magnesium nitride,  $Mg_3N_2$ , were described. It will be remembered that magnesium was shown to combine with nitrogen in a most vigorous manner when heated to redness in a stream of the gas. M. Ouvrard, in the current number of the *Comptes rendus*, shows that lithium too combines energetically with nitrogen. A quantity of this metal was placed in a small boat constructed of iron, the only convenient substance which will withstand the action of fused lithium, and the boat was placed in a combustion tube through which a stream of nitrogen was driven. Upon gradually raising the temperature of the tube and contents, a point was attained, in the neighbourhood of low-redness, when combination suddenly occurred, the metal becoming brilliantly incandescent and increasing rapidly in volume, while the nitrogen in the apparatus was almost entirely absorbed. On continuing the stream of nitrogen until the apparatus became quite cold, the lithium nitride was found in the form of a black spongy mass. Its composition was proved by analysis to be  $Li_3N$ , analogous to magnesium nitride,  $Mg_3N_2$ , and to ammonia,  $H_3N$ . Indeed, it may readily be converted into the latter gas by heating it in a stream of hydrogen. It behaves with water very similarly to magnesium nitride, at once decomposing that liquid with liberation of large quantities of ammonia and formation of a solution of lithia.

THE additions to the Zoological Society's Gardens during the past week include two Macaque Monkeys (*Macacus cynomolgus* ♂ & ♀) from India, presented respectively by Mr. B. H. Heald and Mrs. E. Day; a Rhesus Monkey (*Macacus rhesus*) from India, presented by Mr. Alfred J. Hayward; two Common Squirrels (*Sciurus vulgaris*), British, presented by Master Fred Corfield; two Ring-necked Parakeets (*Palaornis torquatus*) from India, presented by Miss Heinekey; six Mantell's Apteryx (*Apteryx mantelli*) from New Zealand, deposited.

OUR ASTRONOMICAL COLUMN.

WOLF'S NUMBERS FOR 1891.—*Comptes rendus* for January 18 contains a communication by M. Rodolf Wolf on the state of solar activity in 1891. The following table shows the results of solar observations made at Zurich Observatory, and magnetic observations made at Milan. The relative numbers (*r*) have been obtained by the method used in previous years.

1891.	<i>r</i> .	Increments on the relative numbers in 1890.	Variations of magnetic declination.	Increments on the variations of declination in 1890.
January	17.1	11.0	3.71	0.69
February	23.0	22.1	4.51	-0.30
March	10.0	4.7	7.85	0.36
April	19.4	17.9	10.58	1.90
May	43.2	38.6	10.70	3.00
June	48.7	47.3	10.36	1.52
July	59.1	47.7	10.98	2.41
August	32.6	24.9	9.96	1.96
September	52.1	35.4	8.55	1.45
October	50.4	39.3	8.49	-0.23
November	41.0	33.8	4.73	1.63
December	30.6	23.4	8.85	0.31
Means...	35.6	28.8	7.77	1.22

The relative numbers and the magnetic variations show a decided increase on the values obtained for 1890, and the parallelism between the two series continues as in former years. A discussion of these and previous results indicates that the last minimum of solar activity has the date 1889.6.

A NEW JOURNAL.—The *Sidereal Messenger* has ceased to exist under this title, and has merged into *Astronomy and Astro-Physics*. The first copy of this new journal has recently been published in America. Its production is the natural result of the development of astronomical physics. One portion of the journal is to be devoted to general astronomy, whilst the other deals with astro-physics. The editor of the former is Mr. W. W. Payne, who so ably conducted the *Sidereal Messenger*, and the latter section is under the charge of Prof. G. E. Hale, whose excellent works on solar prominence photography are known to all spectroscopists. If the editors can fill future numbers of the journal with so many interesting and important articles and notes as make up the first number, they will attain a well-deserved success. Many of the articles have been published in other journals, but this, of course, does not in the least detract from the value of the new journal. The literature of spectroscopy is truly said to be widely scattered, and Prof. Hale is doing a meritorious work in bringing it all together.

KOREA.

AT the meeting of the Royal Geographical Society on Monday night, the paper read was on a journey through North Korea to the Ch'ang-pai Shan, by Mr. Charles W. Campbell. Ch'ang-pai Shan, or "Ever White Mountain," is the same as Peik-tu San, or White Head Mountain, and "The Long White Mountain," so graphically described by Mr. James in his book of that title. It lies in Manchuria, just beyond the Korean boundary, and is remarkable for the deep-blue lake which lies in a deep hollow on the ridge joining two of its peaks. It was not till August 1889 that Mr. Campbell succeeded in leaving Seoul, the capital of Korea. He journeyed east and north along the coast. The country traversed is typical of the centre and north of the country.

"Korea," Mr. Campbell said, "is a land of mountains. Go where you will, a stretch of level road is rare, and a stretch of level plain rarer still. The view from any prominent height is always the same; the eye ranges over an expanse of hill-tops, now running in a succession of long billowy lines, now broken up like the wavelets in a choppy sea, often green with forest, but just as often bare, brown, and forbidding. Clear mountain brooks or shallow streams rushing over beds of gravel are never wanting in the valleys below, where a rude log bridge, or curling smoke, or the presence of cultivation, leads you to observe the brown thatch of some huts clustered under the lee of a hill. These hamlets are of two distinct kinds—the purely agricultural, and those which depend as much on the entertainment of travellers as on farming. The site of the agricultural village is a hill slope facing the south. Over this, low, mud-walled, straw-thatched hovels, each standing in its own patch of garden, which is protected by a neat fence of interlaced stems, are scattered at random, and there is not much attempt at a street anywhere. Every house has its threshing-floor of beaten clay, the workshop of the family. The stream which runs past the foot of the hill, or courses down a gully in its side, is lined with women and girls washing clothes with sticks instead of soap, preparing cabbages for pickle, or steeping hemp. Seen from a distance, these places are quite picturesque. The uneven terraces of thatch are brightened by the foliage and flowers of gourds and melons which climb all over the huts. In the gardens surrounding each house are plots of red chilli, rows of castor-oil plants, and fruit trees, such as peach, apricot, pear, and persimmon.

"The roadside village, on the other hand, is generally a most unlovely spot. The only street is the main highway, which is lined on both sides by a straggling collection of the huts I have mentioned. Heaps of refuse, open drains, malodorous pools, stacks of brushwood for fuel, nude sun-tanned children disporting themselves, men and women threshing grain, and occasionally a crowd of disputants, all combine to make it a very indifferent thoroughfare. Most of the houses are inns or eating-shops. The main gate of the inn leads directly from the street into a quadrangle bounded on two sides by open sheds, which are provided with troughs for the feeding of pack animals, and on the other two sides by the guest rooms and kitchen. The courtyard is untidy, often dominated by a powerful pig-stye, and littered with fodder or earthenware pitchers and vats, whose contents are usually the strong-smelling pickled cabbages and turnips so dear to Korean stomachs.

"The main industry, of course, is agriculture, carried on under

disadvantages inseparable from the mountainous character of the country. In Japan and China we know that persevering care and energy have overcome similar disadvantages, but it is not so in Korea. The terrace cultivation, the irrigation works, and above all the patient, almost fastidious labour, which make the hills of Japan and South China yield their share of the earth's good fruits, are practically unknown. Where water is abundant and easily manageable, the lower reaches of the valleys are taken up with rice, the higher portions with millet, beans, buckwheat, &c. A particularly favourable slope, all the better if it faces the south, is usually as much as the sides of the valley are called upon to contribute to cultivation. There is considerable waste about the paths and paddy-dykes, weeds are rank and numerous, and the prim neatness so conspicuous in Japanese farming is entirely wanting. Much of the newly broken ground is naturally stony, and little effort is exercised to make it less so. However, considering the small amount of labour expended on agricultural operations, the crops are good, and speak eloquently for the fertility of the soil."

Mr. Campbell reached the River Yalu in October, and although he made every endeavour to reach his goal, the snow was so deep, the passes so overhung with accumulations of snow, and his guides so terrified, that he was compelled to turn back when within a mile or two of the summit. Nevertheless, he succeeded in making observations of considerable interest.

"Peik-tu San, or Lao-pai Shan (Old White Mountain) as it is at present called by the Chinese of Manchuria, is the most remarkable mountain, naturally and historically, in this part of Asia. The perennial whiteness of its crest, now known to be caused by pumice when not by snow, made the peoples that beheld it from the plains of Manchuria give it names whose meanings have survived in the Chinese *Ch'ang-pai Shan*, or Ever White Mountain. This designation, obviously assigned to the White Mountain alone, has been extended to the whole range without apparent reason, for no other peak of it, so far as is known, can pretend to perpetual whiteness, whether of pumice or snow. Some 100 miles south-east of Peik-tu San there is a Ch'ang-peik San (Ever White Mountain) which must approach, if it does not exceed, the White Mountain in height, but the Koreans do not credit it with a snowy covering for more than nine months of the year, and a European traveller who has seen it informs me that it is wooded to the summit, quite unlike Peik-tu San, which is bare of forest for the last 1000 feet of its height. The great point of interest in the mountain, apart from its whiteness, is the lake—12 miles in circuit according to Mr. James and his party, the only Europeans who have seen it—which lies in the broad top of the mountain at a height of 7500 feet above sea-level, and is supposed to be the source of the three rivers, Yalu, Tumen, and Sungari. The *Tei Tei-ki*, Great Lake, as the Koreans call it, is the nucleus of a mass of legend and fable. It is a sacred spot, the abode of beings supernatural, and not to be profaned by mortal eye with impunity. Curiously enough, neither Chinese nor Koreans have the faintest notion of the real character of Peik-tu San. The Chinese say that the lake is an 'eye of the sea,' and the Koreans tell you that the rock of which the mountain is composed floats in water, for lumps of pumice were common on the Yalu at Hyei-san." Mr. Campbell's crude geological explanations, that this *cho-san* (ancestral mountain) of Korea was a burnt-out volcano, whose crater had been filled with water by springs, were listened to with polite wonder, and treated with much less credulity than they deserved. He pointed to the black dust, to the clinkers, and to the rocks lining the banks of the Yalu for miles, many of which looked as if they had been freshly ejected from some subterranean furnace, but to no purpose. If the occurrences he spoke of had taken place, they must have been handed down by tradition; and it was useless to cite lapse of time—Koreans are ignorant of geological periods—to people whose history extends as far back as 4000 years ago. According to Mr. Campbell's observation, most of the forest between Po-ch'ön and Peik-tu San grows on volcanic matter, which was without doubt ejected from Peik-tu San during successive eruptions. The general inferiority of the timber herabouts to that which he saw elsewhere in Korea led him to examine the soil wherever an uprooted tree or a freshly-dug deer-pit furnished the opportunity. "Beyond a thin coating of leaf-mould on the surface, there was seldom anything else but pumice, broken to the size of a very coarse sand. According to the hunters, this was the subsoil everywhere in the forest, and to my knowledge it extends for forty miles at least to the south from Peik-tu San.

Nearing the mountain we get the clearest evidence of the character and recency, geologically speaking, of the eruptions which spread this vast quantity of volcanic material over such a wide area. Ten miles due south of the White Mountain, the Yalu, now 8 or 10 yards broad and very shallow, flows between banks like a railway-cutting, sheer, clean, and absolutely devoid of vegetation, for denudation was too rapid to permit the slightest growth." The sections thus exposed were often over 100 feet in depth, and at one of the deepest portions Mr. Campbell counted thirteen layers of black volcanic dust, all varying in thickness, and each separated from the layer above by a thin layer of light-coloured mould. So fine was this dust that the least breath of wind caught it and scattered it freely over the adjoining snow, to which it gave a grimy, sooty appearance.

"The forests of South Manchuria, though uninhabited now, were, we learn from Chinese records, the home of many races in ages past. The comparatively recent kingdom of Ko-ku-rye, which arose in the first century B.C., is said to have occupied the Ch'ang-pai Shan and the head-waters of the Yalu river. Anyone who has travelled through the forests might be inclined to doubt such records, for, excepting hunters' lodges, one never notices a vestige of human occupation. But it must be remembered, on the other hand, that the word *kuk* (Chinese *kuo*), country or kingdom, was applied in the early history of Korea and Manchuria to very limited communities, often to mere villages. The word "tribe" better expresses what the so-called kingdoms actually were; and when we bear in mind their low civilization and the impermanent character of their dwellings, it is not surprising that my hasty journey failed to throw any light on the ancient inhabitants of these forests." Since his return, however, Mr. Campbell was informed by Mr. Fulford that Chinese hunters told him of the discovery by them of human implements—of what kind Mr. Campbell cannot say—when digging deer-pits near the White Mountain.

Mr. James, in a paper read before the Royal Geographical Society in June 1887, described very fully the guild of hunters which practically owns and rules the forests to the north and west of Peik-tu San. The Koreans have no such guild, probably because they have not so much to fear from bandits, but each hunter has a recognized right of ownership over a rudely defined district in the neighbourhood of his hut. Over this he hunts and traps deer in summer, and sable at the beginning of winter, altogether spending about five months of the year in the forest; the remaining seven are passed at his home or near the Yalu, either tilling his ground or living in idleness on the proceeds of hunting seasons. Besides sable and deer, tiger, leopard, bear, pig, and ermine are found here; bear, probably the common brown species (*Ursus arctos*), are said by the hunters to be very numerous in summer. In mid-Korea Mr. Campbell has seen a small black bear with a white patch on his chest (*Ursus tibetanus*), but the Yalu trappers did not seem to know it. Hazel-grouse were the only game-birds he noticed. Throughout the forests insect pests abound in the summer months. Mosquitoes, gnats, and gad-flies make the lives of the settlers perfectly burdensome for two or three months of the year, and ponies and bulls quickly succumb to their attacks. The houses are kept constantly filled with birch-smoke to drive them off; cattle are protected by fires of greenwood in the open; and men working the clearings carry coils of rope made from dried *Artemisia*, which burns slowly and emits a pungent odour, for the same purpose.

#### THE GEOLOGY OF THE HIMALAYAS.

THE twenty-third volume of the Memoirs of the Geological Survey of India, consisting of some 250 pages, is wholly taken up by an account of the geology of the Central Himalayas, by the Superintendent of the Survey, Mr. C. L. Griesbach, C.I.E. The carefully written text is illustrated by some of the most exquisite and instructive photographs of synclinals, folded beds, faults, glaciers, &c., which have ever been produced, to say nothing of the numerous maps and sections.

We have thought it best to give Mr. Griesbach's conclusions on the important subject with which he deals in his own words:—

The Himalayan region forms part of the vast structure of the Central Asian elevation; it is so closely connected with the latter, both structurally and geographically, that it is very

difficult to decide its exact limits. Native geographers and the Puranic scriptures define the Hīmālayas as comprising only the chain of snowy peaks at the head of the Ganges drainage. Modern views generally limit the Hīmālayas to the system of mountain ranges which extend between the Brahmputra and Indus rivers. Of course, structurally, these ranges continue beyond these boundaries, but there are distinct changes in the features of the ranges which make these limits advisable. As regards the lateral extension of the region, several views have been formed; but I consider it most convenient, and at the same time more in accordance with the original significance of the term, to call Hīmālayas only the system of ranges which fringe the Tibetan highlands along its southern margin, a view which is now most generally held. That part of the system in which rise the headwaters of the Ganges drainage, and extending north-westwards as far as the Sutlej gorge, I call here the Central Hīmālayas, and within this area I divide the Central ranges into (1) Northern range (watershed), and (2) Southern range (line of highest peaks).

Whilst the Southern range of the Central Hīmālayas is formed chiefly of crystalline rocks, mostly gneissic with metamorphic schists, it is shown that the Northern range is almost entirely composed of a vast sequence of sedimentary strata, ranging from the lowest palæozoic to tertiary and recent age. The detailed description of these various formations I have given in the preceding pages, and I will here only recapitulate the following points.

Immediately on the crystalline schists reposes an enormous thickness of beds of varying lithological character, named haimantas by me, which are sharply defined near its upper limit by most characteristic red quartz shales, which form the base of the richly fossiliferous lower silurians. Structurally, this system is very much more fully developed than the succeeding silurians, being in most sections more than double the thickness of the latter. But the lower limit of the haimantas is obscure; an almost perfect lithological passage may be traced from the crystallines (vaikritas) into this system, both in the western and easternmost sections described.

One of the most characteristic amongst the various horizons in this system is a great thickness of a coarse conglomerate or boulder-bed, which in some sections alternates with slaty beds, but is never entirely absent. This, in conjunction with the ripple-marking which may be seen on nearly all the slaty beds of the haimantas, indicates clearly that we must suppose the ancient coast-limits of haimanta age to have been in close proximity. The apparent overlap of haimantas on gneiss (Niti area) is easily explained, if we suppose this system to have been developed in this region as a littoral formation. It is extremely probable that one of the earliest Hīmālayān disturbances occurred immediately before haimanta times.

Lithological resemblance, not less than structural features, point to the probability that a part at least of the slate series of the Lower Hīmālayas are equivalents of the haimanta system of the Central Hīmālayas. I believe even that some of the older rocks, which immediately underlie the Vindhian group, may yet be found to belong to the same age. It would thus follow that the haimanta seas had extended not only over the greater part of the present Hīmālayān area, but perhaps also as far south as Central India. If so, the line of the Central Hīmālayas was probably marked out as a chain of elevations, from the waste of which the boulders and pebbles of the haimanta conglomerate and of the Simla rocks were derived. The latter supposition is also advanced by the authors of the "Manual."<sup>1</sup>

The palæozoic group forms an uninterrupted sequence from the lowest haimantas to the upper carboniferous; and this sequence is the same, or nearly so, in all the sections of the Central Hīmālayas. The first indications of a disturbance are noticeable in the upper carboniferous. Certain beds of the latter are wanting in some sections, and I found the next following system overlapping what I must look upon as an eroded surface of upper carboniferous.

Nearly everywhere I found the latter overlaid by a great sequence of beds, which represent permian, trias, rhætic, and lias. This group of systems forms an uninterrupted sequence, with conformable bedding throughout. The base of the sequence is everywhere seen to be dark crumbling shales, which contain a palæozoic fauna, probably permian in character, which gradually passes into lowest trias beds through dark limestones and shales which have yielded a curious fauna, some of the species of which have strong affinities with permian forms. On it rest

lower trias beds, followed by a continuous succession of strata, which reach up into the lower lias.

The same condition prevails in Spiti, where the lower lias is also well represented.

The lias limestones and shales are overlaid by jurassic (Spiti) beds, which have yielded a large number of fossils, but which have not yet been entirely examined. Most of them appear to belong to the upper jurassics rather than middle or lower. Whether the latter is represented or not, is not quite clear, but the bedding of the Spiti shales is isoclinal with the lower lias, and if there is an unconformity between these systems, it may only be conjectured from the sudden and entire change in lithological character of the two formations, coupled with the absence of lower jurassic forms amongst the species found in the Spiti shales.

From this formation there is a gradual passage into the greenish shales and sandstones of the cretaceous (with perhaps upper jurassic), the Gieumal sandstone of Stoliczka. Again a sudden change in lithological character from these sandstones into the white limestone of the upper cretaceous seems to point to the probability of there having occurred physical changes on a large scale after the deposition of the lower cretaceous. In the Central Asian area, and also in the Perso-Afghan region, a strongly marked overlap of the upper cretaceous over the neocomian limestones may be observed.

Probably similar features will be found to exist in the Hīmālayān area, the cretaceous rocks of which have not been closely studied.

The tertiary system is fully developed, though few fossils were found in it. A great unconformity occurs between certain sandstones which cannot be older than upper eocene (overlying *nummulites*), and are probably of miocene age, and horizontal beds of clay, sand, gravels, and sandstone, which form the high table-land of Hündés, which, having yielded mammalian bone remains, are commonly known as the ossiferous beds of Hündés.

From the foregoing it will be seen that special disturbances must have occurred in early geological times, and have been repeated periodically.

It is very certain that near the beginning of the haimanta era sufficient physical changes have occurred not only to completely alter the lithological character of the deposits in course of formation, but also the area in which the latter were laid down. The great thicknesses of coarse conglomerates, which are of wide-spread extent in the lower haimantas, indicate the nearness of land at the time, or, as I may term it, the existence of an early region of elevation in place of the present area of the Central Hīmālayas. At the same time lithological, not less than structural, conditions point to the probability of true haimanta deposits having been laid down also on the south slope of what is now the Central Hīmālayān region.

The compression of the Hīmālayān, and indeed entire Central Asian area, and consequent folding, and thus elevating of it, most probably went on uninterruptedly and continuously from the earliest epochs to the present; indeed, the natural forces exerted on the surface of our globe condition this. But in addition to this, periodical greater changes have taken place, and are proved by the sections of the Central Hīmālayas.

After the lower haimanta recession of deposits from the entire Hīmālayān area into well-defined northern and southern regions of formations, we find an undisturbed sequence of beds till the upper carboniferous, when clear evidences of a great overlap may be observed. This is well marked in the Central Hīmālayas, and is clearly proved in the Perso-Afghan area, where carboniferous marine limestones are followed by littoral deposits, the upper beds of which contain a triassic fauna. Here we have therefore a period of sub-aerial and marine erosion of the carboniferous, followed by an overlap of probably a permian and triassic sequence of deposits.

The third period of disturbance seems to belong to the lower jurassic age, where a gap (partial or otherwise) between lower lias and middle or upper jurassics is probable.

I may mention that this gap is not observable in the Perso-Afghan region, where the passage from the trias into jurassics and neocomian is gradual.

On the other hand, a decided overlap on an immense scale has occurred in later cretaceous times in Central Asia, and we find that hippuritic limestone covers both jurassics and neocomian unconformably. Such is less apparent in the Central Hīmālayas, though probable enough when considering the sudden change from the sandstone and shales of the lower cretaceous to the hard white and grey limestone of the upper cretaceous.

The fifth period of disturbance, which is clearly shown in the

<sup>1</sup> Page 679.

Central Himálayas, occurred after the deposition of the sandstones which overlie the *nummulites* of Húndés, and which are probably of miocene age. A considerable gap seems to exist between the latter and the ossiferous younger tertiaries which fill the Húndés basin.

There is clear evidence, therefore, of very early disturbances having taken place in the Himálayian area. There are abundant proofs that minor changes in the distribution of land and water have occurred not only frequently, but we can scarcely believe otherwise than that the forces which have resulted in the intricate folding and crumpling of the great sequence of sedimentary and crystalline strata must have been of very long duration, and were probably existent from the very earliest date when the first grain of sediment was deposited in the Himálayian seas. We can go further. Whatever other—and as yet only dimly understood—forces were at work to produce this contraction and folding of the earth's crust, we know of two forces about which there can scarcely be the slightest doubt. The first is the gradual cooling of our earth, and consequent lessening and shrinking of the surface of it. Secondly—and this is a force which may be mathematically expressed—we know that the centrifugal force endeavours to move every point on the surface of the earth in a direction opposite to that in which gravitation attracts it.

The actual force exerted is the resultant between the centrifugal and tangential forces, and it has the tendency, if I may so express it, of gradually moving each point on the surface of the earth towards the equator. It may be supposed that an enormous sequence, of to a certain extent pliable deposits, trying to move bodily, as it were, towards the equator, but *en route* arrested and banked up against a rigid mass of which the peninsula of India is a small remnant only, must necessarily have suffered wrinkling, and lateral crushing.

These forces operated since the earth existed, and must be active now. But throughout the great sequence of the paleozoic, mesozoic, and kainozoic deposits, we search in vain for an internal explanation of the great unconformities and disturbances of coast-line which have taken place at certain intervals, such as I have sketched out above. That these changes were not local overlaps only is apparent when we compare the Central Himálayian area with the Perso-Afghán region. In the latter the physical changes are far more clearly marked. At the close of the carboniferous epoch, which was one of pelagic conditions in the Hindu Kúsh area, Khorassán and Persia, the distribution of land and water must have considerably changed, as we find immediately above the carboniferous limestone, shaly beds with coal-seams, and conglomerates and partly littoral, partly freshwater conditions prevailed in that area till late into jurassic times. These disturbances, which are slightly indicated in the Himálayas, are clearly shown and occur on a larger scale in the West Central Asian area.

The next great change in the Perso-Afghán area is the great overlap of the upper cretaceous (hippuritic) limestone over the neocomian, already alluded to. It has resulted in a great and often strongly expressed unconformity. Again, another and strongly marked change occurs in the middle tertiaries of the Perso-Afghán area. The purely marine miocene beds are overlaid, often with isoclinal bedding, at other localities distinctly unconformably, by upper tertiary freshwater deposits. If the folding and crushing process were alone the cause of these—shall I call them cycles of disturbances—then at least some evidence of it should be observable within the sequences of rocks as we see them.

On the other hand, there is no direct evidence to show that the raising of the Himálayas as a mountain system was in any way due to these periodical fluctuations of sea-level, or, as Suess terms it, the "positive" and "negative" movements of the liquid covering of the earth. The evidence of the transverse valleys in the Himálayas points even to the probability that the raising up of the chains of hills forming them, *i.e.* the folding and crumpling of its rock strata, must have kept pace, step by step, with the erosion by rivers which we now find traversing the whole width of this mountain system.

Such transverse valleys, however, can only date since the last of the periodical changes spoken of, *i.e.* since the middle tertiary epoch. Before that time, up to the point when the last marine tertiary deposits were laid down along the margin of the Himálayas, the relative position of Peninsular India and Central Asia must have been the reverse of what we know them to be now; that is to say, the surface of the Central Asian elevated *massif* must have been nearer the centre of our earth

than the surface of the continent, of which the Peninsula [of India forms only a portion of the remains.

It is improbable that the folding action alone has been the cause of the present structure and orographical features of Central Asia and the areas south of it: for the final great changes which have resulted in the draining of Central Asia of the tertiary seas, of which nothing now remains but isolated salt-water lake-basins, such as the Aral and the Caspian are, we must look for other causes.

Possibly such may be found in the sinking in of large portions of the southern hemisphere which caused the submergence of the Indo-African area below what is now the Indian Ocean. With it the part now known to us as the Peninsula of India may have partially broken down, though of that we have no direct evidence, unless the improbability that the Central Asian area could have been pushed up to its present elevation above the Peninsula entirely through being folded might be adduced as proof. Large tracts of Central Asia we know could never have suffered folding to any but very slight extent, as, for instance, the greater part of the tertiaries of the Turkistán region which are often in undisturbed horizontal position. On the other hand, these latter are but little raised above—some are even depressed below—the level of India.

In all these considerations and speculations two points seem probable almost beyond doubt, namely: First, that the last and main disturbance of physical conditions of the Central Asian area has taken place in post eocene, perhaps in middle tertiary times, and is most likely still continued to the present day.<sup>2</sup> Secondly, that this period of disturbance coincides with the sinking in of the Indo-African continent, which "breaking down" caused the final draining of the tertiary seas from the Central Asian area.

Not so certain is whether the raising *en bloc* of the Central Asian mass above the level of the Indian Peninsula is due only to the folding process, or whether some movement downwards of the Peninsula, in connection with the sinking in of the Indo-African region, may not have had a share in producing the present configuration of the Húndés plateau. Some such movement may be conjectured. Certain supposed elevations of the Peninsula may possibly be owing to "negative" movements of the area of the Indian Ocean—in other words, to the sinking in of the ocean bed.<sup>2</sup>

#### SCIENTIFIC SERIALS.

*American Journal of Science*, January.—Theory of an interglacial submergence in England, by G. Frederick Wright. The theory of deep interglacial submergence which has been propounded to account for the shell-beds at Moel Tryfan, near Snowdon, and at Macclesfield, is opposed by several formidable objections, viz. (1) the subsidence must have been one which affected North Wales and central England without affecting the region south of the Thames and Bristol Channel; (2) there is in other places a considerable absence of marks of subsidence over the northern part of the centre of England, where it is supposed to have been the greatest; (3) the Pennine Chain is not more than 25 or 30 miles wide from east to west, yet east of Macclesfield there is an entire absence upon its flanks both of glacial deposits and of beach lines; (4) the shell beds are strictly confined not only to the area which was demonstrably covered by glacial ice, but to those more limited areas which were reached by ice that is known to have moved in its way over shallow sea-bottoms; (5) the assemblage of shells is not such as could have occurred in one place in the ordinary course of nature. The author develops a system of glaciers which will explain the facts at present known, upon the supposition of a single glacial epoch.—The Permian of Texas, by Ralph S. Tarr. It is shown that the Permian of Texas is, like other areas of Permian, a deposit in large measure made in an inland sea.—The chemical composition of iolite, by O. C. Farrington. The formula obtained from two analyses of exceptionally pure specimens of the mineral is  $H_2O \cdot 4(MgFe)O \cdot 4Al_2O_3 \cdot 10SiO_2$ , the ratio of MgO to FeO in the two cases being as 7 : 2.—On a series of cesium trihalides, by H. L. Wells; including their crystallography, by S. L. Penfield. Upon adding bromine to a concentrated solution of cesium chloride, a bright yellow precipitate was obtained, from which crystals were formed having the composition  $Cs.Cl.Br_2$ . An attempt has been made to

<sup>2</sup> "Manual," pp. lvi., 68o, &c.

<sup>2</sup> See "Manual," p. 68r.



prepare all the members in the following series, and, with the exception of Nos. 4 and 10, all of them have been isolated (1) CsI<sub>3</sub>, (2) CsBrI<sub>3</sub>, (3) CsBr<sub>2</sub>I, (4) CsClI<sub>2</sub>, (5) CsClBrI, (6) CsCl<sub>2</sub>I, (7) CsBr<sub>2</sub>, (8) CsClBr<sub>2</sub>, (9) CsCl<sub>2</sub>Br, (10) CsCl<sub>3</sub>. The characteristics of these compounds have been fully studied.—The law of elastic lengthening, by J. O. Thompson. The author has made an extended and thorough investigation on Hooke's law. The experiments were carried out at the Physical Institute of the University of Strassburg, with the advice and help of Prof. Kohlrausch. They lead to the following conclusions:—(1) The generally accepted law of elastic lengthening,  $x = \alpha P$ , according to which the lengthening  $x$  is proportional to the stretching weight  $P$  is only an approximation. (2) The relation between elastic extension and stretching weight can be expressed by an equation of the following form:—

$$x = \alpha P + \beta P^2 + \gamma P^3.$$

(3) The modulus of elasticity of the undeformed body can be calculated with the help of the equation

$$\left(\frac{dx}{dP}\right)_{P=0} = \alpha.$$

(4) The true moduli of elasticity, calculated in this way, may be as much as 16 per cent. larger than those determined in the ordinary way. Consequently it will be necessary to recalculate physical constants which depend on the modulus of elasticity.—A method for the quantitative separation of strontium from calcium by the action of amyl alcohol on the nitrates, by P. E. Browning.—The relation of melting-point to pressure in case of igneous rock fusion, by C. Barus. From the experiments on diabase the relation of melting-point to pressure at 1200° is  $dT/dp = .021$ ; at 1100°,  $dT/dp = .029$ . And since the probable *silicatic* value of  $dT/dp = .25$  at 1170°, and as this falls within the margin (.020 to .030) of corresponding data for organic substances such as spermaceti, paraffin, &c., it is inferred that the relation of melting-point to pressure, in case of the normal type of fusion, is nearly constant, irrespective of the substance operated upon.—The discovery of Clymenia in the fauna of the Intime-cens zone (Naples beds) of Western New York, and its geological significance, by John M. Clarke.—A new meteoric iron from Garrett Co., Maryland, by A. E. Foote. A plate accompanies this paper.—Farrington, Washington Co., Kansas, aërolite, by G. F. Kunz and E. Weinschenk.—The skull of *Torosaurus*, by O. C. Marsh.

SOCIETIES AND ACADEMIES.

LONDON.

Royal Society, January 21.—“Additional Observations on the Development of *Apteryx*.” By T. Jeffery Parker, B.Sc., F.R.S.

The paper is founded upon the study of three embryos of *Apteryx australis* obtained since the author's former communication on this subject was written.

The youngest (stage E') is intermediate between E and F of the former paper, the next (F') between F and G, the most advanced (G') between G and H.

In E' the characteristic form of the beak has already appeared.

In F' the pollex is unusually large, giving the fore-limb the normal characteristics of an embryo wing.

Several important additions and corrections are made to the former account of the skull, especially with regard to the prephenoid region, the basi-cranial fontanelles, and the relations between the trabecular and para-chordal regions.

The account of the shoulder-girdle is amended. In *Apteryx creneni* the coracoid region is solid, and no pro-coracoid appears ever to be formed: in *A. australis* a ligamentous pro-coracoid is present at a comparatively early period (stage F', and perhaps E').

An intermedium is present in the carpus in all three specimens, in addition to the elements previously described.

The brain in stage G' is interesting, as being at what may be called the critical stage; the cerebellum is fully developed, and the optic lobes have attained the maximum proportional size and are lateral in position. In all essential respects the brain of this embryo is typically avian.

Royal Microscopical Society, January 20.—Dr. R. Braithwaite, President, in the chair.—The Society adjourned after passing a vote of sympathy and condolence to His Royal Highness the Prince of Wales (Patron of the Society) on the sad loss he had sustained.—This being the annual meeting, the President's address, which was to have been read, was therefore postponed till the next meeting, February 17.

EDINBURGH.

Royal Society, January 4.—Prof. Sir W. Turner, Vice-President, in the chair.—Dr. Noel Paton read a paper on the action of the auriculo-ventricular valves. It has hitherto been supposed that, when these valves close, the two flaps are floated up by the fluid, and, partially overlapping, prevent the passage of the fluid by being pressed against each other. Thus it has been supposed that, when closed, the upper surface of one flap presses against the under surface of the other. Dr. Paton has found, by direct experiment, that the flaps remain, on the whole, in a pendant position, the upper surfaces of the two being pressed together.—Mr. John Aitken read the second part of a paper on the number of dust particles in the atmosphere of certain places in Great Britain and on the Continent, with remarks on the relation between the amount of dust and meteorological phenomena.—Dr. Thomas Muir read a paper on a theorem regarding a series of convergents to the roots of a number. The investigation was suggested by some work of the late Dr. Sang. The series does not converge rapidly, and so cannot be of great practical use.—Mr. Malcolm Laurie read a paper on the development of the lung-books of *Scorpio*, and the relation of the lung-books to the gills of aquatic forms. He was led to investigate this subject by observations made on the allied fossil forms described in his paper read at the previous meeting of the Society. He concludes that the lung-books are not formed by a process of invagination, as is usually supposed to be the case. He considers that the cavities are formed by the growth of a protecting plate which finally adheres to the body.

SYDNEY.

Royal Society of New South Wales, November 4, 1891.—H. C. Russell, F.R.S., President, in the chair.—The following papers were read:—Notes on Artesian water in New South Wales, by Prof. David.—On the constitution of the sugar series, by W. M. Hamlet.

December 2.—H. C. Russell, F.R.S., President, in the chair.—The following papers were read:—On kaolinite from the Hawkesbury sandstone, by H. G. Smith.—Notes on some New South Wales minerals (Note No. 6), by Prof. Livesidge, F.R.S.—Notes on the rate of growth of some Australian trees, by H. C. Russell, F.R.S.—Some folk-songs and myths from Samoa, translated by the Rev. G. Pratt, with introductions and notes, by Dr. John Fraser.

PARIS.

Academy of Sciences, January 18.—M. Duchatre in the chair.—Obituary notice on the late Sir George Biddell Airy, by M. Faye.—On the mass of the atmosphere, by M. Mascart. It is shown that the determination of the mass of the atmosphere by observations of the pressures at the surface is open to serious objections, and involves a notable error. The mass, calculated by means of the formulæ developed by M. Mascart, is one-sixth greater than that usually obtained. The quantity of air situated at a height of 64 kilometres is 1/700 of the total mass. Particles of ice and water are suspended at this height, although the air is so rarefied. It is therefore presumed that the density does not diminish uniformly with increase of height above sea-level, but decreases more slowly in high than in low strata. [On this point see a note in NATURE, p. 259.]—New note on the resistance and small deformations of helical springs, by M. H. Resal.—On solar statistics for 1891, by M. Rodolf Wolf. (See Our Astronomical Column.)—Observations of Wolf's periodic comet, made in 1891 with the great equatorial of Bordeaux Observatory, by MM. G. Rayet, L. Picart, and Courty. Observations of position are given, extending from June 27 to December 27.—On integrals of differential equations of the first order, possessing a limited number of values, by M. P. Painlevé.—On an arithmetical theorem of M. Poincaré's, by M. Victor Staniévitch.—On organic compounds as solvents for salts, by M. A. Etard.—Action of carbon monoxide on iron and manganese, by M.

Guntz. Pure finely divided manganese, obtained by heating an amalgam formed electrolytically, at 400° completely absorbs pure carbon monoxide as follows:— $Mn + CO = MnO + C$ . The reaction is probably the same in the case of iron. This explains the facility with which C is taken up by iron in the blast furnace. The spongy iron reduces  $CO_2$  and finely divided C is deposited in contact with the  $FeO$  formed; at a higher temperature the  $FeO$  is reduced by  $CO$ , when the metallic  $Fe$  readily takes up the finely divided C intimately mixed with it.—Action of carbon on sodium sulphate, in presence of silica, by M. Scheurer-Kestner.—Lithium nitride, by M. I. Otvrad (See Notes).—Action of phosphorus pentachloride on ethyl oxalate, by M. Ad. Fauconnier (See Notes).—On the thermal value of the substitution by sodium in the two alcoholic hydroxyl groups of glycol, by M. de Forcrand.—An isomeride of camphor, by M. Ph. Barlier.—The fixation of iodine by starch, by M. E. Rouvier.—The rotatory power of silks of different origin, by M. Léon Vignon.—Action of boric acid on germination, by M. J. Morel.—Contribution to the embryology of *Smicra clasipes*, by M. L. F. Henneguy.—On some new Coccidia, parasites of fishes, by M. P. Thélohan.—On the prevention of hicough by pressure on the phrenic nerve, by M. Leloir. Five years ago the author was consulted by a girl twelve years of age who hicoughed every half-minute. She was thus prevented from sleeping, or masticating her food, and her life was despaired of. Anti-spasmodic prescriptions were tried in vain. After pressing the left phrenic nerve, however, for about three minutes, the hicoughing disappeared. The method has since been successful in many other cases.—On the muciferous apparatus of Laminaria, by M. Léon Guignard.—On the dorsal insertion of the ovules of: Angiosperms, by M. Gustave Chauveau.—On chloride of sodium in plants, by M. Pierre Lesage. It appears that when *Lepidium sativum* and *Raphanus sativus* are watered with a solution of sodium chloride the elements of this salt are found in these plants, consequently a certain proportion of each is absorbed by the plants.—Observation of a lunar corona on January 14, 1892, by M. Chapel.

## BERLIN.

Physical Society, January 8.—Prof. Kundt, President, in the chair.—Dr. Kurlbaum described a surface-bolometer which he had constructed in conjunction with Dr. Lummer. It is cut out of platinum foil whose thickness is 0.012 mm., and possesses the great advantage of very rapidly coming to rest. It is a trustworthy instrument for the measurement of the differences in luminosity of two sources of light.—Dr. Fringsheim described a lengthy series of experiments made in order to determine whether the emission of light by gases is the outcome of mere elevation of temperature, or whether electrical or chemical processes play a necessary part in their incandescence. Sodium vapours were found to yield their characteristic spectral lines and absorption spectra, when passed through a highly heated porcelain tube, only in the case where chemical processes (of reduction) could be ascertained to take place inside the tube. In the absence of these reduction processes, both the emission and absorption of light by the sodium vapours were wanting. The experiments further showed that Kirchhoff's law holds good not only for the emission of light resulting from a rise of temperature, but also for that which results from chemical processes, since in all cases the emission spectrum corresponded absolutely to the absorption spectrum.

Meteorological Society, January 12.—Prof. Schwalbe, President, in the chair.—Dr. Sprung exhibited his improved sliding-weight balance, demonstrated its mode of action and extreme sensitiveness, and explained its use in the registration of changes of atmospheric pressure, temperature, and humidity.—Prof. Boernstein spoke of a case of extraordinarily rapid evaporation from both the surface of his body and his clothing, which he had recently observed while on a glacier. He expressed his belief that the evaporation was due to the lesser tension of aqueous vapour, for any given temperature, over a surface of ice as compared with its tension, at the same temperature, over a surface of water. Dr. Assmann put forward the view that the phenomenon was due to the extreme and sudden dryness of the air often observed in elevated regions, and to the powerful effect of solar radiation.—Dr. Andries read a passage from Virgil's "Æneid" which contains a most clear description of a cyclone.

Physiological Society, January 15.—Prof. du Bois Reymond, President, in the chair.—Dr. Max Levy described his experiments on the influence of blood-supply to the skin on the secretion of sweat as seen in the paw of the cat. He found that blood only supplies the material necessary for the secretion. Secretion can be obtained even after complete occlusion of the blood-vessels supplying the glands. After anaemia lasting for 35 minutes the sweat-glands are paralyzed, but can recover their functional activity even after having been deprived of blood for five hours.—Dr. Th. Weyl gave an account of the results of his experiments on animals (pigeons and fowls) rendered immune to anthrax. When anthrax spores were introduced on a silk thread under the skin of these animals, the spores retained their full activity at the end of one day's sojourn under the skin. If kept there for a longer period, they lost some of their virulence, and were found to have become quite harmless at the end of six days in the pigeon, and three or more in the fowl.

Erratum.—In the report of the Meteorological Society for December 1, 1891 (see NATURE, vol. xlv. p. 168) for "maximum and minimum thermometer" read "sling thermometer."

## BOOKS, PAMPHLETS, and SERIALS RECEIVED.

BOOKS.—Cooley's Cyclopædia of Practical Receipts, 2 vols., 7th edition; W. North (Churchill)—Manual of Chemical Technology: N. von Wagner; translated and edited by W. Crookes (Churchill).—The Human Mind, 2 vols.: J. Sully (Longmans).—The Rainfall of Jamaica: M. Hall (Stanford).—The Horse: W. H. Flower (Kegan Paul).  
PAMPHLETS.—A New Departure in Astronomy: E. H. (Chapman and Hall).—Hand-book on Viticulture for Victoria (Melbourne, Brain).—Royal Commission on Vegetable Products: I. Ensilage; II. Perfume Plants and Essential Oils (Melbourne, Brain).—Report upon the Condition and Progress of the U.S. National Museum during the year ending June 30, 1891; C. B. Goode (Washington).—List of Institutions and Foreign and Domestic Libraries to which it is desired to send future Publications of the National Museum (Washington).—Te Pito te Henua, or Easter Island: W. J. Thomson (Washington).—Aboriginal Skin Dressing: O. T. Mason (Washington).—The Development of the American Rail and Track, as illustrated by the Collection in the U.S. National Museum: J. E. Watkins (Washington).—Preliminary Hand-book of the Department of Geology of the U.S. National Museum: G. P. Merrill (Washington).—Les Odeurs: M. C. Henry (Paris, Hermann).  
SERIALS.—Zeitschrift für Wissenschaftliche Zoologie, liii. Band, 3 Heft (Williams and Norgate).—Morphologisches Jahrbuch, xviii. Band, 1 Heft (Williams and Norgate).—Bulletin of the Buffalo Society of Natural Sciences, vol. v. No. 3 (Buffalo).—Records of the Geological Survey of India, vol. xxiv. Part 4, 1891 (Calcutta).

## CONTENTS.

	PAGE
The Astronomical Theory of the Glacial Period.	
By Prof. G. H. Darwin, F.R.S. . . . . .	289
Popular Zoology. By A. R. W. . . . . .	291
Physiological Chemistry for Medical Students . . . . .	292
Our Book Shelf:—	
Cox: "Problems in Chemical Arithmetic" . . . . .	293
Letters to the Editor:—	
The Theory of Solutions.—Prof. W. Ostwald . . . . .	293
A Simple Heat Engine. (Illustrated).—Frederick J. Smith . . . . .	294
The Migration of the Lemming.—W. Duppacrotch; W. Mattieu-Williams . . . . .	294
The New Forest Bill, 1892.—H. Goss . . . . .	295
A Brilliant Meteor.—Thomas Heath . . . . .	295
On some Points in Ancient Egyptian Astronomy. (Illustrated.) By J. Norman Lockyer, F.R.S. . . . .	296
On the Number of Dust Particles in the Atmosphere of Various Places in Great Britain and on the Continent. By John Aitken, F.R.S. . . . .	299
John Couch Adams . . . . .	301
Water Hood Fitch . . . . .	302
Notes . . . . .	302
Our Astronomical Column:—	
Wolf's Numbers for 1891 . . . . .	307
A New Journal . . . . .	307
Korea. By Charles W. Campbell . . . . .	307
The Geology of the Himalayas . . . . .	308
Scientific Serials . . . . .	310
Societies and Academies . . . . .	311
Books, Pamphlets, and Serials Received . . . . .	312

THURSDAY, FEBRUARY 4, 1892.

## CARPENTER BY DALLINGER.

*The Microscope and its Revelations.* By the late William B. Carpenter, C.B. M.D., F.R.S. Seventh Edition, by the Rev. W. H. Dallinger, LL.D., F.R.S. (London: J. and A. Churchill, 1891.)

THE earlier editions of Dr. Carpenter's "Microscope" had a satisfactory basis. They formed an excellent guide to the use of the instrument, in days when microscopic technique was far less elaborated than it is now, written by an enthusiastic and experienced worker. Dr. Carpenter told us about the theory of the microscope and the different kinds of stages, rack-works, and objectives which he himself had seen and tried; and then gave a somewhat casual and purely personal account of different animal, vegetable, and mineral structures which had been investigated with the microscope, and had especially excited his interest and attention. The book was valuable because it contained the advice and judgment of a great authority, and original observations upon a heterogeneous assemblage of objects by a highly competent naturalist. The later editions of the book, even in Dr. Carpenter's hands, lost a good deal of the original character of the work. New matter of all kinds was fitted in, until the volume became very bulky. Still, the selection of material was made by one man, and the work might be regarded as his note-book, his conception of what was most interesting and instructive in the wide field of microscopic research. An edition of such a book by other hands after the death of the original author is not likely to be a real success, though it may justify a publisher's commercial foresight. Dr. Carpenter's name is a good one to trade with; but as a matter of fact there is not much of Dr. Carpenter in the present work, and what there is has only impeded the naturalists who have assisted Dr. Dallinger in elaborating its contents. The result is very confusing: the reader often is at a loss to know whether a statement is one surviving from Dr. Carpenter himself or is introduced by the new editor.

The book really consists of five treatises compressed into a single volume, no one of which excepting the first is by any means complete. These treatises are: (1) on the theory of microscopical optics, and the history and present development of the compound microscope and accessory instruments; (2) on microscopic technique; (3) on the vegetable kingdom and vegetable histology; (4) on the animal kingdom and animal histology; (5) on the microscopic structure of minerals and rocks.

The first of these treatises is a new and original work by Dr. Dallinger, and occupies five chapters. It contains a valuable exposition of the theory of modern objectives, and some interesting records of ancient microscopes. The statements on p. 209, as to the introduction of the Hartnack model and objectives into this country, and the motives which led to it, are entirely erroneous. I had a large share in that innovation; and I have no hesitation in stating that what led to the importation of German and French microscopes direct from their makers was the simple fact that one obtained an efficient instrument for about one-fourth of the price exacted at that time by

English makers for an instrument of no greater practical value; whilst it was also the fact that English dealers (not the great makers) were in the habit of selling inferior Continental objectives (rejected by their makers) as their own "make," at higher prices than would suffice to purchase first-rate glasses from the Continental firms. The result of the diversion of English purchasers to Continental stands and objectives was the simplification of English models, and an enormous reduction in the price of English-made objectives.

The treatise on section-cutting, mounting, use of reagents, &c., is necessarily short, and lacks that completeness and authority which can alone make a laboratory guide really useful. But the chapter on practical microscopy is a really valuable one, giving the matured conclusions of the editor as to the true methods of getting the best possible performance from the instrument. The English school of microscopists is unrivalled in the services which it has rendered to the development of the microscope as an instrument of precision, and in the cultivation of the art of obtaining from it the most perfect optical results by skilful management of illumination, &c., as also of rightly judging and correcting those results. The high eulogy passed on the Royal Microscopical Society (p. 340), in view of its services in this field, is amply warranted. It is, however, to be regretted that the name of the late Dr. Royston Pigott, F.R.S., is omitted from the history here given of the improvements in condensers, objectives, and eye-pieces. His valuable contributions to the subject were rejected by the Society in 1870, and published in the *Quarterly Journal of Microscopical Science* at that period.

The last three treatises are what give the book its strange and almost incomprehensible character. There can be no doubt that Prof. Bell would have written an excellent original treatise on microscopic animals, and Mr. Bennett an equally valuable one on microscopic plants; but they have not been asked to do this. They and others, and the editor himself, have contributed fragments which are mixed up with fragments of the original Carpenter in inextricable confusion.

The "Author," with his capital A, appears as of old, but he will now receive credit for opinions he never held, and would probably have rejected. The present editor is, however, careful to take responsibility himself for a very remarkable statement—namely, that the saprophytic *Monadinæ* (such as *Monas Dallingeri* of Sav. Kent and others)

"possess features that ally them to the vegetable series, and indicate affinities with certain Nostocaceæ and the Bacteria; while a leaning to the Mycetozoa [already classed by our editor among Fungi!] and the chlorophyllaceous Algæ, and even some forms of Fungi, is quite apparent to the careful student."

It is somewhat startling at the present day to come across conceptions of this kind—groups "leaning" this way and that, with remote affinities to half-a-dozen incompatible ancestries. One would like to know in plain English whether Dr. Dallinger considers that the *Monadinæ* have descended from Nostocaceæ, or from Mycetozoa, or from green Algæ, or any of the latter from any of the former, or all from a common ancestor; and what grounds he has for his view as to their genealogy.

Many of the old topics enlarged upon by Carpenter are treated with increased amplitude in the present edition. Excellent plates (some of them coloured) illustrate the Desmids, the Diatoms (the old *crux* of the sculpturing of the valves is more than ever to the fore), the Monads, the Rotifers, and the Foraminifera. Three coloured plates of the structure of Acari are introduced; they are very interesting, but surely out of proportion in a work on the microscope where no adequate illustrations of the Ciliate Infusoria are given, and where the account of the phenomena of conjugation in that class is far from being up to date both as to statement and illustration.

I do not wish to speak unkindly of an old friend, even when rigged out in such a strangely variegated new set of clothes as are those furnished to "The Microscope" in its seventh edition. There is a great deal of very interesting matter; there are numbers of excellent woodcuts and plates in the book, some old and a great many new—one thousand in all. The defect of all the earlier editions remains in the present—namely, that whilst you may find several pages, plates, and figures about one subject connected with microscopy, you will find only three lines or nothing at all about another. So long as Dr. Carpenter wrote successive additions to the book, one understood why some subjects should be treated fully and others passed over, and at any rate one knew who was responsible for any statement or omission. Now the book has (so far as its second half is concerned) lost its authoritative character, and is more than ever a patchwork of paragraphs on arbitrarily selected subjects, the responsibility for which is divided in some mysterious way between the editor (who, of course, does not claim to be another Carpenter), and certain Fellows of the Royal Microscopical Society.

I should wish, on the other hand, to express the opinion that the first half of the book (which alone really deals with the microscope and the art of microscopy, and is not by Dr. Carpenter, but entirely new—by Dr. Dallinger) is a work of high scientific value—by far the best on the subject—and one which every worker with the microscope should thoroughly study and take to heart.

E. RAY LANKESTER.

#### ELEMENTARY THERMODYNAMICS.

*Elementary Thermodynamics.* By J. Parker, M.A. (Cambridge: University Press, 1891.)

IN a six-lined note, which does duty as preface, the author of "Elementary Thermodynamics" tells the beginner what to omit. From a beginner's stand-point the book must therefore be judged. A first glance will probably startle the reader into exclaiming, What can Kepler's laws have to do with Carnot's principle? Fortunately, however, the sections containing Kepler's laws, and much other apparently irrelevant matter, are those the beginner is advised not to read. With the mere remark that all this is preliminary to an elementary exposition of Darwin's calculations in tidal friction, it will best serve all purposes to confine the attention strictly to things thermodynamic. The most important chapters, alike from the teacher's and pupil's points of

view, are the first and third, dealing with the foundations of the science.

The first chapter is headed "The Conservation of Energy." It develops in mathematical form the general differential equation of energy, but is lamentably feeble in the physical or experimental side. True, there is a brief discussion of some of Joule's experiments; but we venture to think it would require a greater than Joule to find that a calorie was equivalent to 41,539,759<sup>8</sup> ergs! A little further on, the latent heat of ice under a pressure of one atmosphere is given as 79<sup>25</sup> calories, or 3,292,025,964 ergs!! Surely it "was the most unkindest cut of all" thus to spurn the 0<sup>15</sup>. The truth taught here is, that ten-place logarithms do bare justice to "Parkerian" reductions.

A novelty of treatment is the division of forces into *contact-forces* and *ether-forces*. To Prof. Lodge is ascribed the doubtful honour of having suggested this treatment. Contact-forces, we are told, exist between particles in contact; while "the principal ether-forces in Nature which do work, in addition to gravitation and radiation forces, are those which give rise to chemical, physical, electric, and magnetic actions." It is not easy to see the exact meaning of the word "physical" in this definition. If it includes elasticity, cohesion, adhesion, and capillarity, why should pressure, impact, and frictional effects be excluded? Is there, indeed, any evidence of the existence of contact-forces (in Mr. Parker's sense) between particles? To our gross senses, visible masses seem to get into contact with each other; but, when once we introduce an ether as the *vera causa* of all actions between bodies not in apparent contact, we are compelled to regard this ether as an ocean in which matter is an archipelago of particles or a swarm of maelstroms. How, then, can "contact-forces" exist at all, since ether must intervene between particle and particle? In any case an elementary text-book is hardly the place to introduce crude ethereal speculations.

Chapter iii. is devoted to "Carnot's Principle," and these two most significant words form head-lines to 136 pages of a book that just tops the 400. This is good. Nevertheless, the "principle" itself, so far as we can discover, is never once explicitly stated. The chapter opens with a brief historic sketch, in which we are told that Clapeyron brought Carnot's work "prominently" forward in 1834. Yet it was not till fourteen or fifteen years later that Thomson discovered to the scientific world the greatness of Carnot, and clearly pointed out the necessity for modifying Carnot's reasoning so as to bring it into accord with the true theory of heat. From Thomson's second paper (1849) Clausius dates his inspiration. Of all this Mr. Parker says nothing, nor does he seem to be aware that Thomson, two years before Clausius and Rankine published anything, pointed out how Carnot's principle led to the conception of an absolute scale of temperature. Moreover, there can be no question that Thomson first gave an unexceptionable enunciation of the "axiom" underlying Carnot's principle. Such particulars are probably of no interest to an author who defines "the very important axiom . . . substantially due to Carnot" in language which may be thus paraphrased: No mechanical work can be gained from a cycle of operations imposed upon a system in

thermal communication with two bodies only which are at the same temperature. As a basis for the second law, is not this like Samson shorn of his locks?

But in the really important demonstrations Mr. Parker uses, as a logical equivalent of this, an axiom which again is nowhere given explicitly, but may be thus enunciated: During a complete cycle, in which the working substance is in thermal communication with two bodies each at a constant and uniform temperature, it is impossible for a positive quantity of heat to be absorbed from the one and no heat whatever to be exchanged with the other body. The general truth of this "axiom" will be admitted rather because it agrees with Carnot's principle than because of any inherent merit it may itself possess. An axiom must appeal to experience at bottom; and if one had striven to evolve the said axiom in the most unaxiomatic guise attainable, one could hardly have succeeded better. Sad, indeed, *his* lot whose introduction to Carnot's principle is through such tortuous paths!

But the impression gathered from a careful consideration of Section 49 is that the second implied form must be regarded as simply another statement of the first implied form of "Carnot's axiom." Take, for example, the following argument:—

"The quantities of heat absorbed by the system from the two bodies A, B [each at a constant and uniform temperature] during any complete cycle cannot both be positive. For we could then, by expending work in friction, cause the system to undergo a cycle of operations in which a positive quantity of heat was absorbed from one of the bodies A, B, and no heat at all received from or parted with to the other. In other words, we should be able to take heat from a body whose temperature was uniform and constant, and transform it into work without the presence of any other body of different temperature, contrary to Carnot's axiom."

Little good would be served by criticizing these statements at length, which seem to contain at least as many assumptions as sentences. It would be interesting to know what becomes of the work spent in friction, so arbitrarily introduced, and so cunningly disregarded. After all, however, although the second implied form of "Carnot's axiom" may be generally true, it certainly is not so in the particular case in which the one body is at absolute zero. This is quite as conceivable a contingency as the realization of the assumed thermal conditions of the bodies A and B.

After having, by a perfect volley of *reducciones ad absurdum*, reduced all reversible cycles, working between the same temperatures, to the same efficiency; Mr. Parker introduces Thomson's absolute scale of temperature in the usual form  $\frac{q_a}{q_b} = \frac{\theta_a}{\theta_b}$ . Then should come (since it has not come earlier) the proof that the reversible cycle has more efficiency than any other conceivable cycle. But all we find is this sentence:—

"It will be easily seen that, if the irreversible cycle be non-frictional,  $q_a/q_b$  will be equal to  $\theta_a/\theta_b$ , and that in all other cases it will be less."

"It will be easily seen" is easily said, and throws the burden of the proof upon the intelligence of the learner—the proof of what is the kernel of the whole of thermodynamics. And *this* is teaching!

We are firmly convinced that after reading this third chapter the average student will have the haziest ideas of what reversibility means, will be utterly at a loss to know what Carnot's principle really is, and will look upon the "conception of entropy" as a phrase to conjure by. It is with decided feelings of relief that we pass on to chapter iv., "Applications of Carnot's Principle." It may be well to remark here that chapter ii., "On Perfect Gases," discusses the simpler thermodynamic properties of the ideal gas obeying Boyle's and Charles's laws. The experimental truth established by Joule, that the heat absorbed by such a gas is equal to the work done by it during the expansion, is made the basis of the whole inquiry. In both these chapters the ground covered is familiar. For example, Thomson and Joule's experimental determination of the absolute zero of temperature is given with commendable fullness. Critical points, latent heats of saturated vapour, and certain aspects of solution and capillarity are all treated in due order, and with sufficient fullness of numerical detail to make them thoroughly intelligible. In the fifth and sixth chapters, again, we are introduced to the thermodynamic potential. We are not aware that the general energy methods of Massieu and Helmholtz have ever before been presented in connected form to English readers. This Mr. Parker has done, and has deservedly earned our tribute of praise. Anyone who is familiar only with the earlier methods by which the founders of the modern theory grappled with the subject, will find these two last chapters, and especially chapter vi., particularly interesting.

The author is not, however, to our mind so happy in his account of Gibbs's thermodynamic surface as, from the tenor of his introductory remarks, we had expected him to be. After animadverting upon "the very brief notice in Maxwell's 'Theory of Heat'" of "this beautiful geometrical construction . . . which does not seem to have obtained the attention it appears to deserve," Mr. Parker proceeds presumably to give it this attention. But what do we find? Five pages of not very lucid description as against Maxwell's eleven and a half. Perhaps, however, this is of small consequence; for, beautiful though it be as a bit of geometry, the thermodynamic surface, even in concrete form, is of doubtful efficiency in the presentation of thermodynamic truth.

Mr. Parker's book possesses not a few merits, but is marred as an educational work by many faults, chief among which is the tangled presentation of the second law. It is hard, indeed, to get up much enthusiasm for an author who speaks of the *speed* at which a body cools, who casts a slur upon British meteorology by declaring that the Centigrade is "the only thermometer now used for scientific purposes," and who gives no less than three distinct and irreconcilable estimates of the sun's radiation in as many consecutive pages. The loosely expressed but familiar axiom that "heat cannot flow of itself" up a temperature grade is referred to as an important *consequence* of Thomson's definition of absolute temperature; and of the Maxwell "Demon," and all that therein is, there is not even the suggestion of a hint.

The book ends with an appendix of physical constants compiled from various sources. Otherwise, its usefulness is sadly diminished by lack of an index or even table of contents.

C. G. K.

## THE CENTURY DICTIONARY.

*The Century Dictionary: an Encyclopædic Lexicon of the English Language.* Prepared under the superintendence of William Dwight Whitney, Ph.D., LL.D. In Six Vols. (New York: The Century Co. London: T. Fisher-Unwin.)

THE preparation of an English dictionary on the scale of the present work is a task of enormous difficulty, and Prof. Whitney may be cordially congratulated on the success with which, in association with numerous collaborators, he has accomplished it. In the course of his labours he kept before himself three objects: the construction of a dictionary which might be consulted with advantage for every literary and practical use; a collection of the technical terms of the various sciences, arts, trades; and professions, more nearly complete than any that had ever before been attempted; and the presentation, along with the definitions proper, of such encyclopædic matter, with pictorial illustrations, as should render the work a convenient book of general reference.

One result of this far-reaching plan is that the number of words included is very much larger than the vocabulary of any preceding dictionary, about 200,000 words having been defined. It is impossible, even in such a dictionary as this, to give every word or form of a word that may at some time have been used by an English writer or speaker; but the editor, as a rule, has very properly preferred to err on the side of "broad inclusiveness" rather than on that of "narrow exclusiveness." He has sought to make the work "a practically complete record of the main body of English speech, from the time of the mingling of the Old French and Anglo-Saxon to the present day, with such of its offshoots as possess historical, etymological, literary, scientific, or practical value." A good deal of space has therefore necessarily been given to obsolete words and forms, the inclusion of which will have the warmest approval of all who desire to promote the study, on scientific principles, of the evolution of the English language. An unusual number of "dialectal" and provincial words have also been admitted, and, as was to be expected in the case of a work compiled in the United States, much attention has been given to "Americanisms," some of which are merely survivals of older or provincial English, while others have been generally adopted on this side of the Atlantic. Another cause of increase has been the admission of an immense number of words which have come into existence during the present century through the progress of knowledge and labour, scientific, artistic, professional, mechanical, and practical. Liberal as the editor has been in this direction, no one who uses the dictionary is likely to think that his liberality has been excessive.

It is scarcely necessary to say that the utmost care has been taken with the etymological part of the work. In explaining what has been done in this department, the editor does not express himself happily when he speaks of "the making of the English language" as having begun "with the introduction of Roman rule and Roman speech among the barbarous Celts of Britain." If there is any intelligible sense in which we can talk of the English language as having "begun," we must surely trace its beginning to the formation of the Low Dutch

dialect or dialects from which the most vitally essential elements of our present speech are directly descended. The fact, however, which Prof. Whitney desires to emphasize is that the vocabulary of our language has sprung from various sources, and that for a proper understanding of its characteristic qualities the study of its etymology is on this account of extreme importance. The current accepted form or spelling having been presented, each important word is traced back through earlier forms to its remotest known origin. In revising the proofs of those portions of the work which deal with A and part of B, the authors had the great advantage of being able to consult Dr. J. A. H. Murray's masterly "New English Dictionary on Historical Principles"; and they also express acknowledgments to other writers. The work however, gives ample evidence of independent research; and Prof. Whitney claims that "it has been possible, by means of the fresh material at the disposal of the etymologist, to clear up in many cases doubts or difficulties hitherto resting upon the history of particular words, to decide definitely in favour of one of several suggested etymologies, to discard numerous current errors, and to give for the first time the history of many words of which the etymologies were previously unknown or erroneously stated."

With regard to orthography, we may note that in cases in which English usage and American usage are not identical (as in words like "labour," "traveller," "theatre") both forms are given; a plan with which neither Americans nor Englishmen can reasonably find fault. In the definition of words, the object has been to separate more or less sharply those senses of each word which are really distinct, while over-refinement of analysis has been avoided. As far as possible, the definitions have been arranged historically; and they are illustrated by a very large collection of extracts representing all branches and periods of English literature. Here we are interested mainly in the definitions of scientific terms; and, speaking of these generally, we can say that they are remarkable both for accuracy and for conciseness. Some slips were, of course, inevitable. "Achronical" (given as "acronychal") is thus defined:—"In *astron.*, occurring at sunset: as, the *acronychal* rising or setting of a star: opposed to *cosmical*." This is very misleading, the real meaning being, as we recently had occasion to explain, that in achronical rising and setting "we have the star rising when the sun is setting, and setting when the sun is rising." But, upon the whole, it is most creditable that work over so vast a field, and presenting so many difficulties, has been so efficiently done. On this account alone, even if the dictionary had nothing else to recommend it, it would be of great service both to men of science and to the public.

In the encyclopædic portion of the work, the "Century Dictionary" cannot, of course, be compared with any of the great Encyclopædias. Still, skilful management has enabled the editor to bring together an immense amount of information which will often suffice for the purposes for which it is sure to be looked up. The only important drawback to the plan on which this information has been arranged is that it involves too many cross-references. The illustrations are very numerous, and it is worth noting that old cuts have been used only when better

ones could not be made. Some are excellent, and most of the others are quite up to the level which ought to be maintained in so important an undertaking. Of the typographical style, it may be enough for us to say that the publishers have succeeded in giving what they desired to produce—a page in which the matter is at once condensed and legible.

Altogether, the work deserves to be warmly welcomed in England. Those who possess it will have within reach the best results that have hitherto been attained as to the meaning, the evolution, and the affinities of all classes of English words.

#### OUR BOOK SHELF.

*List of the Snakes in the Indian Museum.* By W. L. Slater.

This list contains the names of 350 species of snakes represented in the collection of the Indian Museum, Calcutta. Of the 350 a large majority, 210, are from the Indian Empire (inclusive of Burma and Ceylon), leaving 68 forms that are known to inhabit parts of British India unrepresented in the collection. When it is remembered how rare and local many snakes are, how many species are known by a single specimen, and how seldom opportunities of collecting occur in such tracts as the remotest hills of Southern India, the Assam ranges, the forests of Tenasserim, &c., which abound in peculiar forms, those who have had charge of the Indian Museum may be congratulated on having succeeded in bringing together representatives of so large a proportion of the Indian Ophidian fauna. The number of species represented in the Museum of the Asiatic Society, the nucleus of the Indian Museum, Calcutta, when the reptiles were catalogued by Mr. W. Theobald in 1865, was about 120, so that there has been an increase of 75 per cent. in 26 years. Altogether, as regards Indian snakes, the Calcutta collection is probably only inferior to that in the British Museum.

The publication of the present list has naturally been greatly facilitated, if indeed it may not be said to have been caused, by the appearance, in 1890, of Mr. Boulenger's work on Indian Reptilia and Batrachia, to which, in his introduction, Mr. Slater fully acknowledges his obligation. A few species have been added by Mr. Slater to those described by Mr. Boulenger as inhabitants of British India.

This is probably the last contribution to Indian geological literature that may be expected for the present from its author, who has, according to an announcement in NATURE for January 21, received an appointment at Eton College. During his brief tenure of the Deputy Superintendship, Mr. Slater has done some useful work for the Indian Museum, especially in completing the catalogue of Mammalia commenced by Dr. J. Anderson.

W. T. B.

*The Living World: Whence it Came and Whither it is Drifting.* By H. W. Conn. (New York and London: G. P. Putnam's Sons, 1891.)

IN this book Prof. Conn undertakes to present a review of the speculations concerning the origin and significance of life, and of the facts known in regard to its development, with suggestions as to the direction in which the development is now tending. The subject is certainly large enough, but the author has prepared himself for dealing with it by careful study of the highest authorities in biological science, and he succeeds in giving a clear, impartial, and interesting account of the main lines of inquiry connected with the theory of evolution. He begins with a general chapter on the sources of "bio-

logical history," indicating the meaning of evidence from fossils, from embryology and anatomy, and from other departments of research. He then expounds the various ideas which have been suggested as to the origin of life, bringing into prominence two propositions which may be distinguished from mere hypotheses. These are (1) that life arose in the ocean, and (2) that the first form of life was the simplest possible condition of living matter, certainly simpler than any living organisms with which we are acquainted to-day, and very likely simpler than the simplest mass of diffused protoplasm. Next comes a summary of the leading facts and speculations about the origin of the animal kingdom; and this is followed by a chapter setting forth "the record from fossils." The work is completed by a general view of the course of animal evolution, a sketch of the history of plants, and a discussion of various questions relating to the probable future of the living world. A list of references is added, which will be of considerable service to readers who may desire to study more minutely the philosophy of evolution.

*Adventures amidst the Equatorial Forests and Rivers of South America; also in the West Indies and the Wolds of Florida.* To which is added "Jamaica Revisited." By Villiers Stuart, of Dromana. With many illustrations and maps. (London: John Murray, 1891.)

A GREAT part of this book relates to travels which took place more than thirty years ago. The work is not, however, less interesting on that account, for the impressions recorded in it are reproduced from letters and journals written at the time and on the spot. The author writes without pretension, and has much that is attractive to say about Surinam, Cayenne, Demerara, the Orinoco, Trinidad, Martinique, and Florida. In the chapters on Jamaica he combines the impressions obtained during his first visit with those made upon him in 1891, when he was present at the opening of the Jamaica Exhibition. Mr. Stuart writes of this island with the strongest enthusiasm. "It is impossible," he says, "to exaggerate its loveliness. The most skilful writers must despair of conveying any adequate idea of its fairy-like charms." He gives an excellent account of the progress made by the people of Jamaica in the interval between his two visits. On all sides he was struck in 1891 by evidences of industry and improvement; and of the coloured population he asserts that they seemed to him the merriest and happiest peasantry he had met with in any part of the world.

#### LETTERS TO THE EDITOR.

[The Editor does not hold himself responsible for opinions expressed by his correspondents. Neither can he undertake to return, or to correspond with the writers of, rejected manuscripts intended for this or any other part of NATURE. No notice is taken of anonymous communications.]

#### Cirques.

FROM two or three of the criticisms of the views in my volume on "The Ice Age in America," concerning cirques, I concluded that there was some misunderstanding as to the thing signified by the word, and accordingly wrote to Mr. Russell, of our Survey, whose views I had adopted, and who has had wider acquaintance with the facts concerning them than anyone else in America. I send you my reply, which you are at liberty to publish if you wish. I am sure all interested in glacial matters will value a communication from so eminent an authority, and will find that much light is shed upon the subject by his recent explorations in the Mount St. Elias district of Alaska.

G. FREDERICK WRIGHT.

Oberlin, Ohio, U.S.A., December 16, 1891.

Department of the Interior, United States Geological Survey,  
Washington, D. C., December 12, 1891.

Prof. G. Frederick Wright, Oberlin, Ohio.

MY DEAR SIR,—Your letter, calling attention to Mr. Bonney's remarks on the nature of *cirques* in a review of your "Ice Age in North America" (*NATURE*, vol. xlv. p. 537), led me to think that possibly all who have written on their character and origin were not considering the same phenomena. In Bonney's paper on the formation of *cirques* (*Quart. Journ. Geol. Soc.*, London, vol. xviii., 1871, pp. 312-324), three conditions are mentioned, which are stated to be most favourable to their production; these are:—

"(1) Upland glens, combs, or terraces, so shaped as to give rise to and to maintain many small streams.

"(2) Strata, moderately horizontal, over which these streams fall, which, by their constitution, yield considerably to the other forms of meteoric denudation."

"(3) These strata must nevertheless allow of the formation of cliffs; and thus perhaps the most favourable structure is thick beds of limestone, with occasional alternating bands of softer rock."

In the High Sierra of California—where the *cirques* are situated, my description of which you quote, and which called forth Mr. Bonney's criticism in *NATURE*—none of the conditions mentioned above, except that the rocks are sufficiently durable to stand in cliffs, have perceptibly influenced the formation of the topographic features under consideration.

The *cirques* are not situated "in upland glens, combs, or terraces, so shaped as to give rise to and maintain many small streams," but are in the very crests of the mountains, and receive practically no drainage from above. They are not in horizontal strata, but in various rocks some of which are highly inclined. The most typical examples occur in granite, which is broken by well-defined vertical joints.

The rocks are sufficiently hard to allow of the formation of cliffs, but this property is requisite for the production of other similar topographic forms, and not an exception peculiar to those in which *cirques* occur.

Not only the *cirques* of the Sierra Nevada, but hundreds of others in the basin ranges of Nevada and Utah, in the Rocky Mountains, and in the mountains of Southern Alaska, have been formed under conditions which are the reverse of those stated by Mr. Bonney.

Another class of topographical forms resembling *cirques* are well known; these are the "alcoves" formed in the edges of *mesas* and table-lands where the rocks are essentially horizontal and usually heterogeneous. They are common in the Catskill Mountains, and all along the borders of the plateau on the west of the Appalachians from New York to Alabama. They occur in the great plateau regions of New Mexico and Arizona, and are common in the cañon walls along the Green and the Colorado Rivers, where they were studied by Powell. Modified examples occur in the sediments of Lake Lahontan, and in the bad lands of Dakota, but in these instances the strata are mostly too soft to stand in vertical walls. I have seen good examples at Table Mountain, Cape of Good Hope, and it is safe to say they will be found wherever nearly horizontal rocks, sufficiently durable to form cliffs, have been cañoned or eroded into *mesas*.

The mode of formation of alcoves is too well known to require detailed description. They are formed by the action of streams cutting niches in precipices, which are enlarged by the dashes of spray from water-falls, by solution, and by the grinding of *débris* in the pools into which waters cascade. Alcoves are most abundant in comparatively low regions, for the reason that when strata are greatly elevated, they usually become inclined or folded; but there is no reason why they should not be found at any altitude, provided the rock conditions favour their formation.

It seems to me that alcoves, and not *cirques*, were formed under the conditions postulated by Mr. Bonney, and that the two are genetically distinct.

Since writing the account of the *cirques* of the High Sierra, quoted by you in "The Ice Age in North America," I have visited the Southern Appalachians and the high mountains of Southern Alaska, always having the various problems of mountain sculpture in mind. The Southern Appalachians are without evidence of former glaciation, while the mountains of Southern Alaska are now undergoing intense glaciation. In the former, *cirques*

are absent, but in the latter they are abundant, especially on the northern sides of the crests of the mountains, and are the sources from which numerous glaciers flow.

The initiation of rain and rill sculpture is well illustrated on the sides of many of the valleys of Southern Alaska; and, as you are well aware, there are many valleys in that region which were formerly filled with glaciers to a depth of 2000 feet or more, but from which the ice has now disappeared. All the minor features due to aqueous erosion on the sides of the valleys, previous to their occupation by glaciers, were removed by the ice. The surfaces were cleared of their old records as the sculpture on ancient monuments was sometimes removed to make room for a new bas-relief. When the ice melted, it left the steep slopes without vertical lines, but more or less deeply scored in horizontal bands. Through analogy with the pene-planes described by Davis, we might call these "pene-slopes." The rain falling on these slopes initiated new lines crossing the glacial grooves at high angles, and forming miniature cañons, which receive numerous branches in their upper courses. Many times, several small stream channels coming together have cut radiating channels separated by buttresses, while below, the stream plunges over cascades or runs through deeply-cut gorges. This miniature sculpture is characteristic of immature drainage on inclined surfaces. The combined excavations made by several tributaries near the heads of these new drainage channels have a somewhat basin-like form, but the interiors of the basins are rough, and divided by ridges, and their walls, although steep, do not approach the vertical. These topographic forms in miniature are clearly the work of rain and rills, and have no complicating conditions, except the nature of the strata in which they are cut, and in the best examples this is homogeneous.

Let us renew our studies in the Southern Appalachians, where, as already stated, no evidence of former glaciation has been detected. About many of the higher summits in that region there are large conical depressions, on the sides of which are many rill channels that converge towards a common outlet. These depressions are many times strikingly crater-like in form, but their sides are sloping, and usually deeply covered with *débris*, but in no instance are they vertical cliffs. So far as can be judged, these depressions are not dependent on rock structure, and are certainly not confined to horizontally bedded rocks, but in the best examples have been excavated in strata that are highly inclined. They occur near the summits of mountains and on the sides of precipitous ridges, and receive little if any drainage from above. They belong genetically to the same class as the miniature excavations on the pene-slopes of Alaska, but are of far greater size; and owing to the disintegration and decay of the rocks, and probably, also, to their fuller development, are much more uniform in contour.

The depressions about the summits of the Southern Appalachians are not *cirques*, but in my opinion, are of the nature of the *prototypes* of *cirques*. The general outline of the model has been secured; but for the final sculpturing, in order to form typical *cirques*, another tool is required. That tool is ice.

Should a climatic change occur which would admit of the accumulation of perennial snow about the summits of the Appalachians, the depressions referred to would be the first to be filled, and would give origin to ice streams of the Alpine type. The *névé* snow accumulating in these depressions would become compacted at the bottom and form glacial ice. As the ice flowed outward, it would remove the *débris* encumbering the sides of the basins and attack the rocks beneath, probably in some such manner as described by Lorange, and quoted by you on pp. 244-45 of "The Ice Age in North America."

I do not feel that we can completely analyze the action of snow and ice in depressions like those in which many glaciers originate, but there are certain considerations which may be suggested in this connection.

It is well known that ice may be moulded by pressure and to flow like a viscous body, while it yields but very slightly to tension. When an attempt is made to stretch it, fracture results. Crevasses therefore indicate tension in the glaciers where they occur.

The crevasses near the upper margins of *névés*, known as *bergschrunds*, are really faults, formed by the subsidence of the *névé* on the lower side of a break. They indicate, as has been suggested to me by Mr. W. J. McGee, that the *névé* where they occur is in a state of tension, and the tendency is for the snow to pull away from the cliffs, and thus tear out portions of the rock to which it adheres. More than this, the crevasses



frequently cut completely through the *névé* and expose the rock beneath to the action of frost. In such instances the rocks are in the best position possible to be acted upon by great changes of temperature. Dark bodies on high mountains absorb heat when exposed to the sun, although the air may be below 32° F.; and melting the adjacent snow, become saturated with water, which freezes as soon as they are in shadow. The blocks thus loosened fall away or are removed by the motion of the *névé*. The tops of the cliffs, however, are protected by a covering of snow. There is frequently a space above the top of the *névé* in summer which is exposed in like manner to the action of the atmosphere. These slopes recede by sapping through the action of frost, and precipices result. While the upper portions of the walls of depressions filled with *névé* snow are being broken away by the tensions in the *névé*, and by atmospheric action, the snow on the lower slopes is under compression, and thus rendered capable of abrading the rocks over which it flows.

The ice, in descending the steep slopes from various sides, impinges with great force on the bottoms of the depressions it occupies, and tends to scoop out rock basins. The result of these combined agencies is seen when the *névé* is removed, and we find amphitheatres with precipitous walls rising immediately above a rock basin lake. In other words, the resulting form is a *cirque* like those of the High Sierra.

So far as my observations extend, *cirques* are confined to mountains on which ice sculpture followed water sculpture. The topographic forms left after the disappearance of the ice are modifications of the antecedent forms due to the action of rain and streams.

In the vicinity of Mount St. Elias, Alaska, the mountain ranges are primarily monoclinal uplifts of geologically recent date, and do not bear evidence of having been deeply dissected by streams previous to the birth of the present glaciers. The ice drainage is largely consequent on the present orographic structure, and *cirques* are usually absent. One remarkable exception to this is furnished, however, by a fine *cirque* on the southern side of St. Elias, which is filled by *névé* snows and drained by a small glacier. Thousands of secondary and tertiary glaciers exist on the southern slopes of the mountains, but of these very few, and so far as my knowledge goes none, of these have their origin in true *cirques*. On the north side of the mountains, however, which are in general the gently sloping surfaces of orographic blocks, topographic forms inherited from former aqueous erosion are conspicuous, and *cirques* are abundant.

Glaciers exist about the summit of Mount Shasta, Mount Ranier, Mount Baker, and other high volcanic peaks in the Cascade Mountains, but none of these, so far as known, originate in *cirques*. These mountains, like the uplifts about Mount St. Elias, are geologically young. They are volcanoes with fumaroles in their craters; and owing to their elevation, and the comparatively slight erosion they have suffered, it is reasonable to suppose that the first precipitation on their summits was in the form of snow. Glaciers were formed on unmodified slopes, but have not excavated *cirques* for themselves. The glaciers on these mountains, like many of the smaller ice streams in Alaska, occur on exposed slopes and not in depressions. The accumulations of snow and ice form prominent convex surfaces and frequently give a characteristic outline to the summits which they cover.

The probable origin of *cirques* which I have traced, together with the fact that they occur in thousands about the summits of mountains on which the glaciers followed water sculpture, together with their absence on unglaciated mountains like the Southern Appalachians, and also the fact that glaciers in themselves do not seem to have the power of excavating similar depressions, is seemingly cumulative evidence pointing to the conclusion stated above.

*Cirques*, alcoves, and possibly other forms, when considered simply as topographic features, may perhaps be classed together; yet, genetically, alcoves and *cirques* are distinct, the former owing their existence to aqueous sculpture, usually in horizontal rocks, and the latter to aqueous sculpture followed by ice sculpture, in rocks which may be heterogeneous or homogeneous, horizontal or inclined.

The generalization that "*cirques* are confined to glaciated regions," to which Mr. Bonney takes exception, was reached from considering the distribution of typical examples, previous to the differentiation of *cirques* from other similar topographic forms. When they are recognized as distinct from alcoves, and

necessarily in part of glacial origin, the reason for their distribution becomes evident, as does also the further generalization that they "occupy localities where glaciers first appear."

In the Rocky Mountains the peaks and ridges on which *cirques* occur have an elevation of from 10,000 to 14,000 feet. The same is true also in the Sierra Nevada. In each of these regions the ancient *névé* fields had generally about the same elevation, while the glaciers flowing from them descend to within 6000 or 5000 feet above sea-level. In Alaska, however, where the former glaciers descended into the ocean, *cirques* occur on peaks and ridges only 3000 or 4000 feet high, and examples may be found at elevations of less than 2000 feet. Their vertical, as well as their geographic range, therefore, appears to have been regulated by the climatic conditions which control the birth of local glaciers.

While "alcove" and "*cirque*" should have a definite significance in geology, amphitheatre, recess, bowl, and other correlative words, may be considered as general terms applicable to more or less inclosed spaces without reference to their origin. The semicircular recesses made by winding streams in the sides of cañons and deep valleys, sometimes resemble alcoves. Craters frequently bear a close topographic similarity to *cirques*, but are readily distinguished when their origin is considered.

On looking over my account of the *cirques* of the High Sierra (Eighth Annual Report, 1886-87, U.S. Geological Survey), I fail to discern any reason for materially changing it, except, as indicated above, to state more definitely the differences between *cirques* and other topographic forms with which they might be confounded.

I remain very sincerely your friend,

ISRAEL C. RUSSELL.

#### Large Meteor of January 24, 1892.

It is to be hoped that further observations will be forthcoming of the brilliant meteor of January 24, 10h. 55m. (described by Mr. T. Heath in your last number, p. 295), so that its real path may be computed. I think there is little doubt the meteor belonged to a shower of Draconids having a radiant-point a few degrees south-east of the star  $\zeta$ . On the same night (January 24) as that on which the fine meteor was observed, I saw a third magnitude shooting-star, at 7h. 55m., with a path from  $324^\circ + 40'$  to  $330\frac{1}{2}^\circ + 31\frac{1}{2}'$ , and this also belonged to the radiant in Draco. I discovered this shower on the nights of January 19 and 25, 1887, and determined the position of the radiant as at  $261^\circ + 63'$ . There are many other showers from the same point in the spring, summer, and autumn months.

Bristol, January 31.

W. F. DENNING.

#### On the Relation of Natural Science to Art.

IN DR. du Bois-Reymond's interesting lecture, as published recently in NATURE, there occurs the following passage (p. 226): "Flaxman" was "certainly mistaken in representing Polyphemus with three eyes—two normal ones which are blind, and a third in the forehead." Does not the recent discovery of a third (parietal) eye in some of the lizard and fish tribes (not to mention the tunicates!) diminish the force of this assertion? Flaxman's genius appears rather to have forestalled the discoveries of science in representing the human monster with three eyes, especially as Wiedersheim states that even in man nerve-fibres have been traced from the optic thalami to the pineal gland.

W. AINSLIE HOLLIS.

Brighton, January 11.

#### Ice Crystals.

The following account of some very well defined ice crystals may be of interest.

On December 26, 1891, the thaw set in. On the 27th, I noticed on the surface of the ice on the lake at Drinkwater Park, near Prestwich, on the outskirts of Manchester, a large number of very distinct, hexagonal, tabular crystals. The surface of the ice was not very wet. These crystals varied from half an inch to three inches across, were raised about an eighth of an inch above the surface of the ice, and in many cases bore a similar but much smaller crystal in the middle, raised about an eighth of an inch above the surface of the larger crystal. In some specimens the smaller crystal was rounded and indis-

tinct. When it was absent, dark lines, following the direction of the lateral axes, were visible in some cases. Frequently an indistinct striation was present.

GILBERT RIGG.

Manchester Museum, Mineralogical Department,  
January 12.

#### A Tortoise inclosed in Ice.

I SHOULD like to be allowed to record a case of a water-tortoise surviving an incarceration in ice, somewhat similar to that given in NATURE (vol. xlv. p. 520).

In this instance, the tortoise has hibernated in a stone basin, in which there were about 6 inches of water and a quantity of dead leaves. The whole was, I believe, frozen into a solid mass. At any rate, when, on December 29, I examined a cake of ice and leaves, from 2 to 3 inches thick, which was floating in the basin after a thaw, I found the tortoise with its back embedded in the *under* side of the mass, and with nearly 2 inches of porous-looking ice above it. The animal, though torpid, was alive, and I replaced it in the basin. Later on it put its nostrils up to the surface, and two days afterwards was seen with its head out of the water as usual. It remained in the pond, which has been again frozen over, in less than a week after this observation.

FRANK FINN.

31 Walton Crescent, Oxford, January 22.

#### Alpine Rubi.

In a footnote in NATURE (vol. xlv. p. 10) it is stated that "The two highest-known species of *Rubi* are *pinnatus* and *rigidus*, at 5000-6000 feet." This is hardly correct, unless it is intended to refer to African species only. In South America, *R. megalloccus*, *R. boliviensis*, *R. bogotensis*, and *R. roseus* occur at 8000 feet, and *R. rusbyi* at 10,000. In Colorado I have found *R. strigosus* above 10,000 feet (see *Bull. Torrey Bot. Club*, 1890, p. 10; 1891, p. 169). In the Indian region, *R. ellipticus* goes to 7000, *R. lasiocarpus* to 8000, and *R. biflorus* and *R. rosifolius* to 10,000 feet.

The name of the wild *Zea* is *Z. canina*, Watson (local name, "maïs de coyote"), not *nana*, as given in NATURE, vol. xlv. p. 39.

T. D. A. COCKERELL.

Institute of Jamaica, Kingston, Jamaica,  
December 30, 1891.

#### UTILIZATION OF HOMING<sup>s</sup> PIGEONS.

THE utilization of the homing instinct of the domesticated varieties of the blue rock pigeon, the *Columba livia*, for military purposes, has been effected by most of the Governments in Europe. In France, Germany, Austria, Switzerland, Italy, Spain, and Portugal the organization has been very complete. It has even extended to Russia, Denmark, and Sweden; and Africa has been brought into communication with Spain by stations at Ceuta and Mellila. England alone, of all the great Powers, has neglected this important mode of communication, which is available under circumstances that preclude the employment of any other means.

It cannot be said that they have not been brought under the notice of the military and naval authorities. Nearly twenty years ago, on the occasion of the despatch of a flight of seventy-two birds from the Crystal Palace to Brussels, when the first birds arrived before the telegram which was sent to announce their departure, I wrote a letter to the *Times* of June 27, 1873, calling attention to their utility, and asking the question: "What would be the value of the birds, in the event of a war in which we may be engaged, that would convey messages to or from Guernsey, Jersey, and other places, when the submarine wires had been cut by the enemy?" and in a lecture delivered by me before the Royal Engineers' Institute at Chatham, on the use of pigeons for military purposes, I entered at some length into their mode of training and general utilization.

The employment of the *Columba livia* depends upon several conditions which are not without interest. In

the first place, this species is one of the comparatively few capable of domestication, a faculty which is totally distinct from, though frequently confounded with, the faculty of being tamed. A domesticated animal is attached to its home, and returns to it of its own will; a tame animal is merely familiar with man. These two states are admirably illustrated in the closely allied species, the fowl and the pheasant. Both were originally perfectly wild, but when domesticated the chickens invariably return home to roost, while the pheasants, though descended from numberless generations of birds bred in confinement, have no attachment whatever to the place of their birth or rearing.

In its natural habitat (the rocky cliffs of the sea-shore) the blue rock pigeon has to fly long distances in search of food, which, when breeding, it stores up in its crop and carries home to its young. This necessitates strong powers of flight and well-developed perceptive faculties, it being guided in its return solely by sight, and not, as is often supposed, by any special instinct.

The pigeons that are used for carrying messages are bred solely for that purpose. A process of artificial selection, as rigorous and remorseless as that of nature, is followed. The young birds, after acquiring their power of perfect flight, and learning the contour of the country in their circuits around their home, are taken in

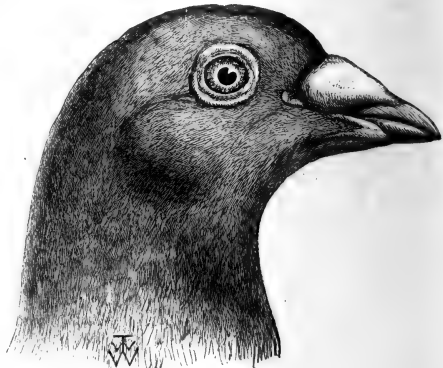

FIG. 1.

the direction in which it is desired that they should fly, and trained stage after stage until they know every locality over which they have to traverse. This training is absolutely necessary, if their return home is to be depended on. During its performance the inferior birds, those whose intelligence and determination are not well developed, are lost; and the best birds, only, retained. This loss, in the long-distance flights which are flown by the Belgians and by the best homing pigeon societies in England, is very severe. Old birds, that know large tracts of country well, may be taken in new directions, provided they are not too extended, with safety, but young birds that have not been trained would almost certainly be lost if carried many miles from their home.

Every homing pigeon flyer recognizes the hereditary character of this acquired faculty, and will give a very high price for birds descended from parents that have flown long distances, whereas he would not purchase another bird of precisely similar appearance were he not acquainted with the performances of its ancestors. The fancy varieties of pigeons, especially those which are called carriers in England, are perfectly useless for the purpose of flying distances.

The birds that are most valued are almost all descended

from the homing pigeons, *les pigeons voyageurs*, of Belgium, in which country the sport of pigeon racing has been carried on for many years, and has attained its highest development. Pigeon races, in which thousands of birds are engaged, take place annually from the south of France, a distance of five hundred miles, to Brussels and the neighbouring parts of Belgium. The birds are characterized by a well-developed brain, hard,

With a strong adverse wind their progress is necessarily slow compared with what it is when the wind is in their favour, but the rate of the winners may be taken from eight hundred to thirteen or fourteen hundred yards per minute. In favourable weather the races from the south of France to Brussels are usually accomplished by the winners in one day, the pigeons never flying after eight o'clock in the evening, the birds being liberated at

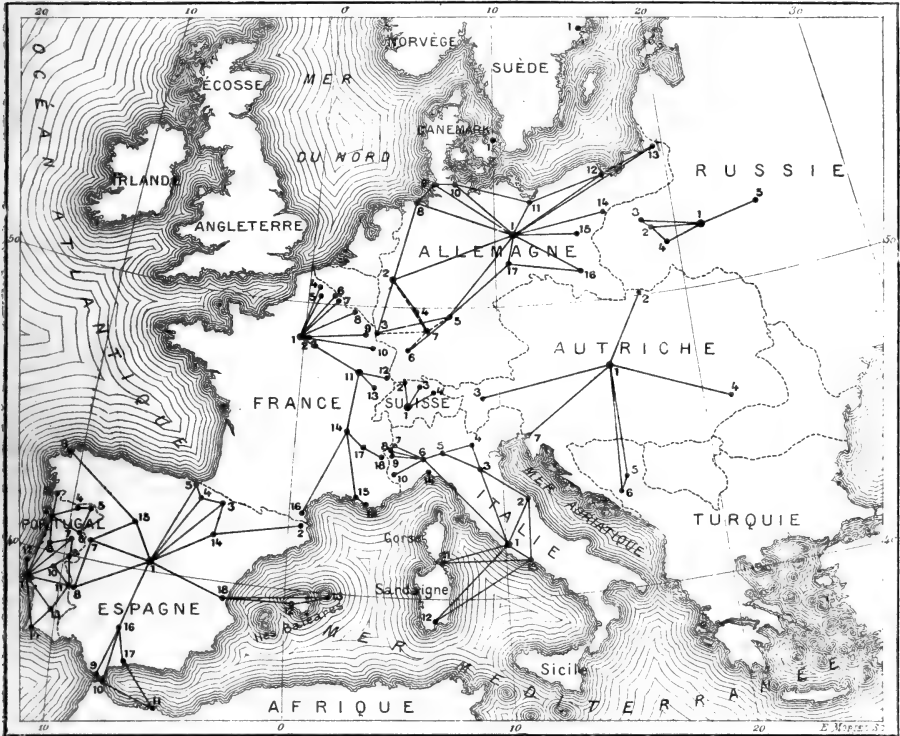

FIG. 2.—CHART SHOWING THE SYSTEM OF MILITARY PIGEON POSTS IN THE CONTINENTAL KINGDOMS.

- FRANCE : 1, Mont Valérien ; 2, Paris ; 3, Vincennes ; 4, Lille ; 5, Douai ; 6, Valenciennes ; 7, Maubeuge ; 8, Mézières ; 9, Verdun ; 10, Toul ; 11, Langres ; 12, Belfort ; 13, Besançon ; 14, Lyon ; 15, Marseille ; 16, Perpignan ; 17, Grenoble ; 18, Briançon.
- PORTUGAL : 1, Lisbonne ; 2, Porto ; 3, Valence ; 4, Chaves ; 5, Bragança ; 6, Almeida ; 7, Guarda ; 8, Coimbra ; 9, Castelo Branco ; 10, Abrantes ; 11, Elvas ; 12, Peniche ; 13, Beja ; 14, Lagos.
- ESPAGNE : 1, Madrid ; 2, Figueras ; 3, Jaca ; 4, Pamplona ; 5, Oyarzun ; 6, Ferrol ; 7, Ciudad-Rodrigo ; 8, Badajoz ; 9, Tarifa ; 10, Ceuta ; 11, Melilla ; 12, Palma ; 13, Mahon ; 14, Zaragoza ; 15, Valladolid ; 16, Cordoba ; 17, Malaga ; 18, Valencia.
- ITALIE : 1, Rome ; 2, Ancone ; 3, Boulogne ; 4, Vérone ; 5, Plaisance ; 6, Alexandrie ; 7, Mont Cenis ; 8, Fenestrelle ; 9, Exilles ; 10, Vinadio ; 11, La Maddalena ; 12, Cagliari ; 13, Gaeta ; 14, Génova.
- SUISSE : 1, Thun ; 2, Bâle ; 3, Zurich ; 4, Weesen.
- ALLEMAGNE : 1, Berlin ; 2, Cologne ; 3, Metz ; 4, Mayence ; 5, Wurtzbourg ; 6, Strasbourg ; 7, Schwetzingen (en projet) ; 8, Wilhelmshaven ; 9, Tonnig ; 10, Kiel ; 11, Stettin ; 12, Dantzig ; 13, Königsberg ; 14, Thorn ; 15, Posen ; 16, Breslau ; 17, Torgau.
- AUTRICHE : 1, Comorn ; 2, Cracovie ; 3, Franzenfeste ; 4, Karlsburg ; 5, Serajewo ; 6, Mostar ; 7, Trieste.
- DANEMARK : 1, Copenhague.
- SUÈDE : Carlsborg.
- RUSSIE : 1, Brest-Litovsk ; 2, Varsovie ; 3, Novo-Georgievsk ; 4, Ivangorod ; 5, Luninetz.

firm plumage, great breadth of the primary and secondary flight feathers, and large pectoral muscles. Fig. 1 is an accurate portrait of a homing pigeon formerly in my possession that had repeatedly flown from the south of France to Brussels. Their rate of flight, for long distances, depends, of course, greatly on the weather.

<sup>1</sup> We are enabled by the courtesy of the editor of *La Nature* to reproduce this map.

daylight in the morning. Fog and mist, hiding the surface of the country, are fatal to rapid progress.

It is sometimes alleged that sight can be of no avail when birds are liberated some hundreds of miles from their home, but it should be remembered that from an elevated position in the atmosphere immense distances can be seen. Mr. Glaisher records that from a balloon he saw at the same time the cliffs of Margate on the west,

Brighton on the south, and all along the coast-line to Yarmouth on the north.

The homing-by-instinct theory is entirely disproved by the races which have taken place from Rome to Belgium, a distance of between eight and nine hundred miles, nearly half of which was over country entirely new to the birds. All the birds engaged in these races had been flown from the south of France to Belgium, whence they would have found their way back in one or two days, but of the hundreds liberated in Rome, not one returned before eleven days, and in the first race in a fortnight only four out of the number despatched. The country was new to them, and doubtless they circled about in search of some known landmark which would have directed their flight; but the objects with which they were acquainted were hidden from them by the Alps, and it was only those few that, flying along the coast, succeeded in reaching the south of France, and then saw objects with which they were acquainted, that returned to their Belgian homes.

The first extensive practical application of the homing faculty of these birds took place when Paris was environed by the German army. During the siege, as is well known, balloons were continually despatched from Paris, carrying not only passengers, but bundles of letters, and the homing pigeons belonging to a few private individuals resident in Paris. In the first instance the despatches returned by these pigeons were photographed on paper and sent from Brussels into Paris. After a time a distinct pigeon post was organized from Tours, outside the German lines. This pigeon post was recognized by the English postal authorities, and letters at the cost of half-a-franc a word were sent from Tours into Paris with as great a degree of rapidity as the pigeons could be sent out by balloon, and conveyed from the places where they descended to Tours, for the purpose of being re flown into Paris. The letters, which were limited to twenty words, were set up in type, micro-photographed on thin films of collodion, inclosed in small quills, and attached to one of the tail feathers of the bird. So complete was this organization that one pigeon could have carried into Paris the whole of the many thousand letters that were sent in during the siege.

The Germans were not slow to utilize the services of the pigeons for military purposes, and at the present time every large fortress in Germany has its pigeon loft, and the birds are trained to fly back from the surrounding country for distances of many miles.

As will be seen by the accompanying map (Fig. 2), pigeons are trained to Berlin from all the large fortresses in the Empire, Strasbourg on the south to Königsberg on the north. Then, again, each fortress has its own loft of pigeons, which are trained to fly back to it, so that before a fortress is completely invaded by the enemy a number of birds can be sent out, or forwarded subsequently by balloon. On being liberated with despatches, these would return to the fortress, without the possibility of their being interfered with. A similar organization prevails in France, pigeons having been trained from Paris to all the military stations on the German frontier; and it may be observed that in Italy, Austria, and even Russia the same system prevails. In our own country there is no definite organization of pigeons for military purposes. It is true pigeon flying has become a popular pastime with a large number of persons. There is scarcely a town in the kingdom where some good homing birds do not exist, which could be placed at the disposition of the military or naval authorities. One great use of the birds would be on the cruisers sent out to watch an enemy's fleet. It is obvious that each could readily take a number of pigeons on board, and, without leaving its post of observation, could send back day by day messages to the town from whence the pigeons were received.

It is doubtful whether any purely military organization

could take as good care of the pigeons, and could train them in a manner superior to that which is done by those who use them for racing purposes. No military or naval servant, unless he were a lover of pigeons, would train them with the same amount of interest and care that is done by the amateurs.

In this country, at the present time, there exists a very large number of pigeon-flying Societies. Their races extend from the midland counties in England as far as Cherbourg, and other parts of France. In actual practice the birds would not be, except under very rare occurrences, required to fly very long distances. Of course these long flights necessitate a considerable amount of risk, but good pigeons can be calculated on to return from fifty to a hundred miles with certainty.

On looking at the map it will be seen that no lines showing the military organization of pigeons appear in Belgium; in fact, it is hardly thought necessary that any distinct organization should take place there, as it is supposed that there are in Belgium alone more than six hundred thousand homing pigeons belonging to private individuals, all of which are well trained, and would, in case of war, be placed at the disposition of Government.

W. B. TEGETMEIER.

#### NOTES.

THE Committee which has been formed for the purpose of obtaining a portrait of Michael Foster, Secretary of the Royal Society, and Professor of Physiology in the University of Cambridge, has issued a second list of subscriptions. It is intended that the picture shall be presented either to the University or to Trinity College, as the subscribers may decide. The treasurer is Dr. Lea, Gonville and Caius College, and subscriptions may be paid either to him or to Messrs. John Mortlock and Co., Bankers (Limited), Bene't Street, Cambridge. Cheques should be made payable to the "Michael Foster Portrait Fund."

At the meeting of the Cambridge Philosophical Society on Monday, January 25, Prof. G. H. Darwin, President, in the chair, the following resolutions were proposed by Prof. Cayley, seconded by Dr. Lea, and passed unanimously:—“(1) That the Cambridge Philosophical Society desires to express its sense of the great loss sustained by the University and the Society by the death of Prof. Adams, who shed lustre on the Society by the brilliancy of his scientific career, and set an example to its members by the earnestness and simplicity of his life. (2) That the Society do now adjourn without transacting the business of the meeting, as a mark of respect for the memory of Prof. Adams, one of the benefactors of the Society. (3) That the President be instructed to convey the foregoing resolutions to Mrs. Adams.”

WE have heard at present of only one astronomer as candidate for the Professorship of Astronomy rendered vacant by the death of Prof. Adams; this is Mr. Turner, Chief Assistant at Greenwich. On the other hand, we hear of some mathematicians; it is not stated, however, what contributions to the science they have made.

THE late Ferdinand Roemer, the well-known geologist and Professor at the University of Breslau, whose death on December 14, 1891, we have already recorded, intended to have celebrated on May 10 next his jubilee as a Doctor of Philosophy; and his friends, admirers, and pupils were preparing to do him honour on the occasion. It is now proposed that a marble bust of Roemer shall be placed in the Mineralogical Museum of Breslau, and an influential committee has been formed for the purpose of collecting subscriptions.

THE Committees appointed last year by the Royal Society and by the British Association for investigating the zoology of

the Sandwich Islands have amalgamated, and at a meeting held one day last month selected, from among the gentlemen who offered their services, Mr. Robert C. L. Perkins, B.A., of Jesus College, Oxford. Mr. Perkins will accordingly leave England in a few days, proceeding *via* New York and San Francisco to Honolulu, where he will at once commence his researches into the fauna of the islands, and especially that part of it which is believed to be threatened with extinction; aided, it is hoped, by the Hawaiian Government, and some of the principal residents. Dr. David Sharp, F.R.S., Curator in Zoology in the Museum of the University of Cambridge, is the Secretary of the Joint Committee.

THE annual general meeting of the Geological Society will be held on Friday, February 19, at 3 p.m., and the Fellows and their friends will dine together at the Hotel Métropole, Whitehall Place, at 7.30 p.m.

THE new law on French Universities is soon to be discussed by the French Senate. The Committee appointed to report upon the Government's plan disapproves of many of its provisions.

M. PIERRE LAFFITTE, the head of the "orthodox" Positivists, has been appointed professor, at the Collège de France, of the history of science.

DR. FRITHOF NANSEN is now in England, his object being to fulfil a series of lecture engagements. The proceeds are to be devoted to the expedition to the North Pole on which he hopes to start next year.

THE Joint Grand Gresham Committee has decided to cooperate with University and King's Colleges and the Medical Colleges of the great hospitals of London in the establishment of the proposed University in and for London, on the understanding that it be called the Gresham University.

DR. ALFRED CARPENTER, the well-known advocate of sanitary reform, died at Ventnor on January 27. He was the author of many works on sanitary subjects. In 1879 he was elected President of the Council of the British Medical Association, having been in the previous year orator of the Medical Society of London.

PROF. E. RAY LANKESTER will on Thursday next (February 11), at the Royal Institution, begin a course of three lectures on "Recent Biological Discoveries"; and Lord Rayleigh will on Saturday (February 13) begin a course of six lectures on "Matter: at Rest and in Motion."

DR. NOETLING, of the India Geological Survey, is now engaged in superintending the sinking of shafts at the amber mines on the Upper Irrawaddy.

AN index to the five yearly volumes of the *Kew Bulletin*, already published, has now been issued as "Appendix IV., 1891." In an introductory note some interesting statements are made as to the history of the *Bulletin*. It was originally intended that a number should be issued only occasionally; but monthly publication was immediately found to be necessary, and further space has since been obtained by the printing of information of a purely formal kind in appendices. The subjects treated have related almost entirely to economic botany. The results of investigations made by members of the staff at Kew and of kindred institutions at home and abroad on vegetable products and the plants producing them, have been carefully summarized and presented in as concise and clear a manner as possible. In many cases the articles have been illustrated by plates from original drawings or by those placed at the disposal of the Director by the Bentham Trustees from the "Icones Plantarum." The *Bulletin* has become a most con-

venient mode of communicating information to persons at home, to the numerous correspondents officially connected with colonial and Indian botanical establishments, and to private persons interested in plant products in distant parts of the Empire. It has also been of service to members of the general public engaged in planting or agricultural business in India and the colonies.

THE fourth part of the first volume (xxi. of the whole work) of the fourth series of Hooker's "Icones Plantarum" has appeared, completing this volume, which is devoted to the illustration, by Sir Joseph Hooker, of Indian orchids of a less conspicuous character than those commonly cultivated. The work is now published for the Bentham Trustees, and sold at four shillings per part by Dulau and Co., of London. The third series, consisting of ten volumes, containing 1000 figures of interesting plants, is on sale by the same firm, at £5 the set. Only a limited issue is printed, and when exhausted it will not be reproduced.

MR. ELLSWORTH has offered to lend for exhibition at the "World's Fair," Chicago, a collection of orchids, including between 1500 and 2000 varieties.

THE Chemical Institute of the Royal University, Rome, has printed a volume of reports on the researches carried on by its workers during the scholastic year 1890-91. Excellent service might be done to science if this example were followed by the laboratories connected with our own Universities.

THE Director of the Colonial Museum at Haarlem has issued a circular notice to the effect that it is of the highest importance for the Museum to have in its library all recent treatises on tropical botany, zoology, products, and cultivation. He begs therefore that authors will send to the Museum a printed copy of their writings on these subjects in the publications of scientific Societies.

THE *Times* of Tuesday, February 2, contains an account of a very peculiar case of prolonged sleep which, on January 31, was occupying the attention of medical circles in Germany. It seems that a miner named Johann Latus, an inmate of the hospital at Myslowitz, in Silesia, has been there 4½ months, and during that time all attempts that have been made to wake him have been fruitless. The doctor attending him, Dr. Albers, thinks that catalepsy is the real cause of his condition, although no previous record of so prolonged a sleep has ever been made in medical science. The fact which has led Dr. Albers to this conclusion is that all the limbs are absolutely rigid. In other respects the appearance of the man betrays no sign of this. The body remains quite still, breathing takes place regularly, and the appearance of the face is quite normal, the cheeks being of a healthy colour. Lately the body has been less rigid and the patient has even made some slight movement, but the eyes have still been kept closed, and the condition of apparent sleep in no way disturbed. During this long sleep the hair on the head has increased in length, but the beard has remained stationary. In order to supply the patient with food a tube has been inserted into the throat, and by means of it two or three litres of milk have been administered daily.

M. KOEBELE, who has been for the second time searching in Australia and New Zealand for "beneficial insects," has discovered that *Orcus chalybeus*, a steel-blue ladybird, is a most important enemy of the red scale. According to *Insect Life*, he has found them by the hundred, and has observed the mature insects eating the scales. The trees were "full of eggs," and the larvæ were swarming on all the orange and lemon trees infested with the red scale. M. Koebele has sent to America a large quantity of the eggs and many of the adult beetles.

ACCORDING to the Berlin correspondent of the *Times*, a curious rosy light overspread the sky above Berlin from 9 till 11 o'clock on the evening of January 26, and made many people think that a great fire had broken out somewhere. Early on the following morning the Emperor telephoned to the central fire brigade station to inquire what had happened, but received answer that the effulgence was a natural phenomenon.

IN March 1891, a Select Committee of the House of Commons was appointed to consider the subject of the registration of teachers. Two Bills which had been introduced into the House of Commons, one by Sir Richard Temple, the other by Mr. Arthur Acland, were referred to the Committee; and it examined a large number of witnesses whose opinions were worthy of being carefully considered. The Report of this Committee has been issued by the National Association for the Promotion of Technical and Secondary Education, and deserves the attention of all who are interested in educational questions. The following are the conclusions at which the Committee arrived: that the registration of teachers in secondary schools is in principle desirable; that any Educational Council to be established for the furtherance of such registration should be composed of nominees of the State, representatives of the Universities, and members elected by the teaching profession; that the qualifications for registration should include evidence both of attainments and of teaching capacity; and that additional facilities are required for the training of teachers in secondary schools. The Committee was of opinion (a) that existing teachers should not be put on the register merely as such, but should not suffer from any legal disability; (b) that both existing teachers and future teachers should be admitted to the register on producing such evidence of intellectual acquirements and teaching capacity as might be required by the Council; (c) that the register should, as soon as might appear reasonable in such case, be made compulsory upon existing teachers in the event of their appointment to teach in a secondary school, assisted by endowments or public money, and upon future teachers in these, and ultimately in all other secondary schools; (d) that teachers certified by the Education Department should be placed on the register, with an indication, as in the case of other teachers, of the nature of their certificate.

THE Committee on the Indexing of Chemical Literature, appointed by the Chemical Section of the American Association for the Advancement of Science, refers with pleasure, in its ninth annual report, to the fact that a new Dictionary of Solubilities is in progress by a competent hand. Prof. Arthur M. Comey, of Tufts College, College Hill, Massachusetts, has written to the Committee that the work he has undertaken will be as nearly complete as possible. He estimates that the dictionary will contain over 70,000 entries, and will make a volume of 1500 to 1700 pages. The arrangement will be strictly alphabetical, and in all cases references will be given to original papers. The Committee also prints a letter *fin* which Mr. Howard L. Prince says that in the U.S. Patent Office, of which he is librarian, an index is being made for about 150 journals, notably those upon the subjects of chemistry, electricity, and engineering, both in English and foreign languages. The general plan is alphabetical, but he departs from it sufficiently to group under such subjects as chemistry, electricity, engineering, railroads, &c., all the subdivisions of the art, so that the electrical investigator, for instance, will not have to travel from one end of the alphabet to the other to find the divisions of generators, conductors, dynamos, telephones, telegraphs, &c. Another fact mentioned by the Committee is that an extensive bibliography of mineral waters is being prepared by Dr. Alfred Tuckerman.

THE Institute of Jamaica has begun the issue of special publications. The first, the Rainfall Atlas of Jamaica, contains thirteen coloured maps showing the average rainfall in each month and during the year, with explanatory text. The maps are based upon observations made at 153 stations from about the year 1870 to the end of the year 1889. The available stations are irregularly distributed, being for the most part sugar-estates and cattle-pens, and in consequence of this irregularity the island has been divided into four rainfall divisions. The north-eastern division has the largest rainfall, then comes the west central, next the northern, and lastly the southern. The annual distribution of the rainfall varies from 30 to 35 inches in a few places to over 100 inches in the north-eastern division. The greatest fall is in October, and the least in February. The driest stations are on the north-eastern and south-eastern shores. The maps show the distribution and average amount of rainfall very clearly by different tints, and cannot fail to be of both scientific and practical utility. The work has been prepared by Maxwell Hall, the Government Meteorologist.

IN the new number of the *London and Middlesex Notebook*, Mr. G. F. Lawrence says that some months ago he obtained a stone hammer of unusual form from the Thames at Hammersmith. It is in the form of a cushion, and is beautifully polished all over. The shaft-hole is  $\frac{3}{8}$  inch in diameter, and is an inch nearer one end than the other. The material is a beautifully veined claystone, of a light greenish colour, and the hammer measures  $4\frac{1}{2}$  inches in length,  $2\frac{1}{2}$  inches broad, and is  $1\frac{1}{2}$  inch thick. Mr. Lawrence knows of only two other specimens of this type which have been found in the southern counties; both are in the British Museum. The Edinburgh Museum, however, contains several, some of handsome material and finish, while others are of a less beautiful, but most serviceable granitic stone. The type seems to belong to the Bronze Age. Such specimens as the Hammersmith example must have been, Mr. Lawrence thinks, more than mere implements. He suggests that they were symbols of chieftainship, and handed down from one to another, as sacred badges of office, as the beautiful jade weapons were in New Zealand.

MR. E. P. RAMSAY, Curator of the Australian Museum, Sydney, has reported to the trustees that during the year 1890 no fewer than 320 specimens were bought for the ethnological collections. The most important of them were a fine lot of greenstone axes and old clay cooking-pots from New Caledonia; fine-made mats, baskets, hats, native hair lines and fishing hooks, from Gilbert and Kingsmill Group; necklaces, drums, and other rare articles of native dress, from British New Guinea; clubs, spears, cava-bowls, and food-baskets, from Viti or Fiji; stone-headed spears, from Bathurst Island, Torres Straits. Among 74 specimens acquired by exchange were a valuable collection of Neolithic worked flints from the Chalk Hills, South Downs, England; worked flints, from the Thames; Palaeolithic worked flints, from the river gravels, near London; polished basalt celts, from Ireland; celt socket, formed of the base of the red-deer, from Swiss lake-dwellings; old English flint and steel, from Yorkshire; modern French peasant's pipe-lighter, flint and steel; iron lamp, or "cruzie," in use since Roman times in Scotland; brass lamp, being a modification of the "cruzie," from Antwerp; cornelian arrow-tips, from Arabia; photographs of Hindu pipes.

AN excellent hand-book on "Viticulture for Victoria" has been issued by the Royal Commission on Vegetable Products in that colony. The work has been compiled by Mr. François de Castella, of whom the Commission says that from training and experience he is especially qualified for the task of preparing a manual for vine-growers. During the last few years a fresh impetus has been given to this industry in Victoria, and Mr.

Castella is of opinion that the amount of wine produced in the colony will soon be very considerable. He recommends that the vine-growers of each district should agree among themselves to produce only one definite type of wine, and that it should be known by the name of the district—such as Rutherglen, Great Western, Bendigo, Mooroopna, and so forth. The label on a bottle would thus give some idea of the contents. To name wine from the sort of grape is useless. Two Rieslings—for instance, one grown on the Yarra and the other on the Murray—differ as much as hock and sherry.

MR. CLEMENT REID read an interesting paper the other evening before the Norfolk and Norwich Naturalists' Society on the natural history of isolated ponds. He selected as typical examples the isolated ponds dug on the South Downs to store water for cattle. These ponds are from 300 to 400 feet above sea-level, supplied by rain and condensation, and quite unconnected with any stream, often far from a road or path; and it appears most unlikely that seeds of the plants, or eggs of the animals, which he found in considerable numbers and variety, can have been conveyed thither by human agency. Both the eggs and the seeds must, he thinks, have been transported chiefly on the feet of birds.

MESSRS. LONGMANS have in the press and will shortly publish a new and revised edition of Sir Philip Magnus's "Lessons in Elementary Mechanics." The book, which has already passed through seventeen editions, has been entirely re-written by the author. It contains several new sections, and especial attention has been given to the subject of units and to the explanations of terms. No change, however, has been made in the general arrangements of the book. A key containing full solutions of all the exercises and examination questions, many of which are new, is ready for press, and will be published about the same time as the new edition.

A BOOK by Prof. A. Targioni Tozzetti on the insects and other animals which injure tobacco has recently been published. Of his 300 pages of text, 270 are devoted to insects, 6 to vertebrates, 7 to snails, 10 to arachnids, and 1 to earthworms. Dealing with the cigarette beetle (*Lasioderma serricorne*), which, of all tobacco insects, does most damage in America, Prof. Tozzetti recommends as a remedy a thorough use of chloroform, bisulphide of carbon, and hydrocyanic acid gas in disinfecting warehouses and manufactories; and he advises, where possible, the submersion of the tobacco in 90 parts of water for forty-eight hours. *Insect Life* says of this advice that it is "evidently not based on experience, and not appreciative of the ease with which tobacco is spoiled for the trade."

IN the last sentence of Mr. Frederick J. Smith's letter on "A Simple Heat Engine" (NATURE, p. 294), for "fall" read "pull."

A SERIES of remarkable compounds of the halogen salts of the rare metal caesium with two more atoms of chlorine, bromine, or iodine, are described by Messrs. Wells and Penfield in the January number of the *American Journal of Science*. The fact was accidentally discovered that when bromine is added to a concentrated solution of caesium chloride, CsCl, a dense bright-yellow precipitate is produced. When the contents of the test-tube are warmed, this precipitate dissolves, but on cooling the same substance separates out in the form of large orange-coloured crystals. Upon analysis these crystals are found to possess the composition CsClBr<sub>2</sub>. This remarkable observation has led to the preparation of a series of eight such salts, each containing one atom of caesium and three halogen atoms. The formulæ of these compounds are CsI<sub>3</sub>, CsBrI<sub>2</sub>, CsBr<sub>2</sub>I, CsClBrI, CsCl<sub>2</sub>I, CsBr<sub>2</sub>, CsClBr<sub>2</sub>, and CsCl<sub>2</sub>Br. They all crystallize well, generally in large brilliant prisms. Those of CsI<sub>3</sub> are

black and almost opaque; those of CsBrI<sub>2</sub> dark reddish-brown by reflected and deep red by transmitted light; CsBr<sub>2</sub>I forms crystals of a bright cherry-red colour; while the crystals of CsClBrI, CsBr<sub>2</sub>, and CsClBr<sub>2</sub> are tinted with various shades of orange. The compound CsCl<sub>2</sub>Br forms bright yellow crystals, the lightest coloured in the whole series. Two other possible salts of the series, CsClI<sub>2</sub> and CsCl<sub>3</sub> have not yet been obtained. The general method by which the above eight salts were prepared consisted in dissolving the haloid salt of caesium employed in water, adding the requisite quantity of iodine or bromine, or leading a stream of chlorine through the solution, and cooling or evaporating to the crystallizing point. The salts are remarkably stable, they may all be preserved for any length of time in corked tubes or bottles. They form an isomorphous group, all crystallizing in the rhombic system. An important relation has been discovered between the crystallographical constants of the first five members of the series, those containing iodine. The ratio of two of the axes remains almost constant throughout the whole of the five, while the third varies with the molecular weight.

THE formation of salts of the nature above described, in which a compound such as caesium chloride, which is usually considered as fully saturated, actually combines directly with two more atoms of a monad halogen element, is a most important and interesting fact considered in connection with the general subject of residual affinity. Caesium, as is well known, is the most electro-positive element yet discovered, and that it should exhibit this phenomenon of residual affinity in so startling a manner is perhaps not surprising. Moreover, Johnson in the year 1877 obtained a tri-iodide of potassium, KI<sub>3</sub>, and also in 1878 an analogous ammonium compound, NH<sub>4</sub>I<sub>3</sub>. The question of the constitution of such salts is a most complex one, but the balance of evidence, particularly that afforded by the crystallographical measurements, is decidedly in favour of considering them as double salts, and not as salts of trivalent caesium. The acceptance of a possible trivalency of caesium would of course be in direct antagonism to the teaching of the periodic generalization, and Prof. Mendeleeff himself considers the two extra atoms of iodine in potassium tri-iodide to be united much in the same manner as the water taken up by many salts upon crystallization.

THE additions to the Zoological Society's Gardens during the past week include a Grey Ichneumon (*Herpestes griseus* ♂) from India, presented by Mr. R. Meinertzhagen; a Lesser White-nosed Monkey (*Cercopithecus petaurista* ♀) from West Africa, deposited; two Snow Buntings (*Plectrophenax nivalis*), a Yellow Bunting (*Emberiza citrinella*), two Reed Buntings (*Emberiza schœniclus*), British, purchased; seven Coypus (*Myopotamus coypus*), born in the Gardens.

#### OUR ASTRONOMICAL COLUMN.

NEW STAR IN THE MILKY WAY.—The following circular was issued from the Royal Observatory, Edinburgh, 1892, February 2:—

Yesterday an anonymous post-card was received here bearing the following communication:—

"Nova in Auriga. In Milky Way, about two degrees south of  $\chi$  Aurigæ, preceding 26 Aurigæ. Fifth magnitude, slightly brighter than  $\chi$ ."

At 6h. 8m. G.M.T. the star was easily found with an opera-glass. It was of a yellow tint, and of the sixth magnitude, being equal to 26 Aurigæ. Examined with a prism between the eye and the eye-piece of the 24-inch reflector, it was immediately seen to possess a spectrum very like that of the Nova of 1866. The C-line was intensely bright, a yellow line about D fairly visible; four bright lines or bands were conspicuous in the green; and, lastly, a bright line in the violet (probably H $\gamma$ ) was easily seen.

A telegraphic notice was sent to Greenwich in the afternoon,

and later on, when the true nature of the object was recognized, to Kiel for general distribution. The star was photographed last night at Greenwich.

Its place for 1892<sup>o</sup> is 5h. 25m. 3s. + 30° 21'. It does not occur in the Bonn Maps.

RALPH COPELAND.

**OBSERVATIONS OF MARS.**—*Publikationen des Astrophysikalischen Observatoriums zu Potsdam*, No. 28, contains the results of some observations of Mars, made by Dr. Lohse during the oppositions of 1883-84, 1886, and 1888. A series of measurements of the position-angle of the northern snow-cap has been made with the idea of accurately determining the direction of the polar axis of the planet. On February 8, 1884, the mean value obtained differed from Dr. Marth's ephemeris by 0° 216, being identical with that deduced from the corrected elements of the axis employed after 1884. In 1888 the distance of the centre of the northern snow-cap from the Pole was found to be 2" 39, and the mean correction of position-angle 0° 896. Reproductions of thirty-six sketches of Mars made in 1884 and 1886 accompany the paper. These show the principal markings, but not the canals and minute details seen by that perspicacious astronomer Schiaparelli, although the instrument used was an 11-inch refractor. The sketches are combined to form a map, on which the position determined with special accuracy is indicated.

At the conjunction of Mars and Jupiter, in October 1883, a determination was made of the comparative intensities of the actinic rays emitted by the two planets. A series of photographs of these bodies was taken with exposures varying from one to twelve seconds, and these were compared with a scale derived from a series taken with an artificial source of light at various distances, and another derived from Vega. The actinic intensity of Jupiter's southern hemisphere was found to be 2.176 times greater than that of the Martian surface, which, when the distances of the two planets from the sun are taken into account, gives 2.4 : 1 as the relative albedos. The ratio of the amount of light emitted by the southern hemisphere of Jupiter to that emitted by the northern hemisphere was incidentally found to be as 1.192 : 0.597.

**SOLAR PROMINENCE PHOTOGRAPHY.**—Some interesting recent results in the photography of solar prominences are stated by Prof. G. E. Hale in the first number of *Astronomy and Astrophysics*. In the first place, the line a little less refrangible than H, which Prof. Hale suggested was probably due to hydrogen, has been proved by M. Deslandres to have its origin in this element, by direct comparison with a Geissler tube. Prof. Young has also succeeded in photographing this line, which was first visually observed by him in 1880. With regard to the line at  $\lambda$  3888.73, which forms a double with the hydrogen line  $\alpha$  ( $\lambda$  3889.14) of the stellar series, Prof. Young has not found the duplicity which very often distinguishes the Kenwood Observatory photographs. The hydrogen line  $\alpha$  occurs on eighteen plates, but it is only certainly single on two of them. And it is a significant fact that in one of these cases only the upper part of the prominence lines was photographed, the light from a short distance above the sun's limb being cut off by a diaphragm. There seems little doubt that the line is a true one, and not a false appearance brought about by the reversal of the hydrogen line on account of which it is apparently duplicated. Its origin, however, is unknown. Prof. Hale thinks that both H and K in prominences are due to calcium, the absence of the strong line at  $\lambda$  4226.3 being said to follow from its different appearance and behaviour in the arc, as compared with H and K. By a remarkable coincidence an eruption on July 9, 1891, was simultaneously photographed at Kenwood Observatory and visually observed by Herr Fényi at Kalosca, Hungary. Copies are given of the drawing and photograph, and the general agreement in the form of the prominence is very striking.

**RE-DISCOVERY OF BROOKS'S COMET (1890 II).**—A telegram from M. Perrotin to Prof. Krueger announces that Brooks's comet was found by M. Javelle, of Nice Observatory, on January 6 (*Astr. Nach.* 3074).

### ELECTROTECHNICS.<sup>1</sup>

I BEG to thank you for the great honour you have done me in electing me your President for this year—a year which the need for a new complete index of this Society's Journal marks

<sup>1</sup> Inaugural Address of Prof. W. E. Ayrton, F.R.S., President of the Institution of Electrical Engineers, delivered on January 28, 1892.

out as closing the second decade of its life; a year which sees the second thousand added to our roll of members; and a year which the Electrical Exhibition at the Crystal Palace distinguishes as inaugurating the second decade of electric lighting in Great Britain.

It has gradually become the custom for your incoming President to select, as the subject of his address, some investigation that has been engaging his attention. Following this custom, I purpose to-night to discuss an experiment in which, for the last nineteen years, I have taken some part—an experiment which, of all others, has been the one I have had most at heart—and that is, how best to train the young electrical engineer.

To some it may appear that I am trading on well-worn ground; but as the problem is one that is as yet by no means solved, and as it involves the preparation of the machine that is daily used alike by the dynamo constructor, the cable manufacturer, the central station engineer, and the lamp maker—viz. the human machine—the problem of fashioning this tool so that it may possess sharpness, an even temper, moral strength, and a mental grain capable of taking a high polish, is one that, in truth, deeply concerns every member, every associate, every student of this Society.

It is only fifteen years ago since I wrote from Japan to my old and valued master, Dr. Hirst, then the Principal of the Royal Naval College, Greenwich, asking whether he thought that the time had come for starting in this country a course of applied physics somewhat on the lines of that given at the Imperial College of Engineering in Japan. He replied that England was not yet ripe for such an innovation—an opinion which appeared to be borne out by the fact that after the authorities at University College, London, had in 1878 actually advertised for applications for a new chair of "Technology," they decided that it would be premature to take the responsibility of creating such a Professorship.

But matters were advancing more rapidly than was imagined by collegiate bodies; for in that same year this most valuable report on technical education which I hold in my hand was issued by a Committee of the Livery Companies of London, based on the opinions expressed by Sir W. (now Lord) Armstrong, Mr. G. C. T. Birtley, Colonel (now General) Donelly, Captain (now Sir Douglas) Galton, Prof. Huxley, and Mr. (now Sir H. Truman) Wood. And although it is twelve years since this book was published, I can recommend it to your notice, for it supplies most interesting reading even at the present day.

Under the guidance of three joint honorary secretaries, Mr. John Watney, Mr. Sawyer, and Mr. (now Sir Owen) Roberts, the City and Guilds of London Institute for the Advancement of Technical Education started, with a name that was very long, but in a way that was very modest, to develop a "Trades School" in accordance with this report. They borrowed some rooms, but for use in the evening only, from the Middle Class Schools in Cowper Street, Finsbury, and decided to erect ultimately a chemical laboratory in that neighbourhood.

But neither the building of a physical nor even of a mechanical laboratory formed any part of the scheme for this "Local Trades School." For at that time the teaching of the applications of physics to industry hardly existed, and certainly not its application to any electrical industry other than telegraphy. To make a start, however, in such teaching was most desirable, and therefore Dr. Wormell, the enlightened head master of the Cowper Street Schools, consented to give up the use of some rooms not merely during the evening, but also during the day, to enable Dr. Armstrong and myself to carry out our plan of fitting up students' laboratories with a small amount of apparatus kept permanently ready in position.

For the devotion of these rooms to the carrying out of this new experiment we must always feel grateful to Dr. Wormell, for it was necessarily accompanied by a reduction in the size of his school, and consequently by a pecuniary loss to himself.

The first laboratory course of the City and Guilds Institute was then advertised, and on January 9, 1880, three students presented themselves—a little boy, a gray-haired lame man, and a middle-aged workman with emphatic but hazy notions about the electric fluid.

In order to further utilize these rooms, the Institute sanctioned laboratory teaching during the day, and one of the cellars of the Cowper Street Schools was borrowed in order to fit up a gas-engine, coned shafting, and a transmission dynamometer, obtained out of the funds of the Institute; an A Gramme dynamo



lent by Mr. Sennett, then one of the students; and two arc light dynamos for transmission of power experiments, lent by the Anglo-American Brush Corporation, whose cordial interest in the work of the City and Guilds Institute has been marked throughout. And as these dynamos were used, not for electric lighting, but as laboratory instruments for educational purposes, England can claim to have been one of the first in the field of teaching electrotechnics.

Rapidly grew these electrotechnical classes; soon the temporary laboratories in Cowper Street were overcrowded, especially as applied mathematics and mechanics, under Prof. Perry, were added to the subjects taught; the £3000 which had been set aside for the building of this "Local Trades School" grew into £35,000, thanks to the combined donations of the Drapers' Company and of the Institute, and in 1881 was laid the foundation-stone of the present Finsbury College.

During the many years that Prof. Perry and I were linked together, the work of either was the work of both; but now I wish to take this opportunity of acknowledging my personal debt of gratitude for the fund of suggestion which he put forth regarding the teaching of science through its practical applications—the keynote of true technical education. The value of these suggestions you will fully appreciate, for they form the basis of those characteristic and attractive lectures familiar to so many of you who have been his pupils.

As we have seen, then, the present Finsbury College grew out of the "Local Trades School," and formed no part of the original scheme of the Institute. And it was because London was really in want of practical laboratory teaching about dynamos, motors, electric lamps, and engines, and because that want was supplied in a form suitable to the comprehension and to the pockets of workmen in the basement and cellars of the Cowper Street Schools, and last, but by no means least, because one of the Executive Committee of the Institute, Mr. Robins, strenuously exerted himself to further technical education in Finsbury, that the various electrical, physical, and mechanical laboratories now in Leonard Street, Finsbury, came into existence.

But the establishment of a Central Technical Institution "for training technical teachers, and providing instruction for advanced students in applied art and science," had been recommended in all the reports sent in to the Committee of the Livery Companies by the six authorities to whom I have referred. So that in the same year that the foundation stone of the Finsbury College was laid by the late Duke of Albany, that of the Central Technical Institution was laid by the Prince of Wales.

And, if you will allow me to say so, the success of the latter institution has been no less marked than that of the former, for, in spite of the rather stiff entrance examination, the number of students who attend all four of the departments at the Central Institution is more than threefold what it was five years ago. In fact, in the mechanical and electrical engineering departments there are already about as many students under instruction as class room and laboratory accommodation will admit. Hence this year will see a considerable increase in the amount of apparatus and machinery, as well as in the space devoted to dynamos and motors, in Exhibition Road.

While, on the one hand, the rapid growth of the work of the Guilds Institute is no little due to the fact that the latter end of this century has ushered in the electric age of the world; the electrical industry of our country, on the other hand, is no little indebted to the aid so generously given by our City Companies to the teaching of electrotechnics. For the students who during the last seven years have, for an almost nominal fee, worked in the electrical laboratories at Cowper Street, at the Finsbury College, and at the Central Institution, number several thousands, and nearly every electrical works, every place giving electrotechnical instruction throughout this country, employs some of them.

The success which these students have thus achieved, through their own ability and exertions, is, I think, in no small measure due to the Institute having so wisely left the teaching it gave untrammelled by any outside examining body, so that it was possible for this teaching to be directed solely to the professional needs of the students, and to be modified from time to time as it seemed necessary.

My hearty thanks are indeed due to the Japanese Government and the City and Guilds Institute, my masters during the last nineteen years, for having left my colleagues and myself unfettered liberty to carry on this experiment of finding out

better and better ways of teaching the applications of science to industry.

And there need be no fear that with this freedom the teaching will become stereotyped, and gradually cease to deal with the living science of the factory, for, being bound by no code, we are able to vary our methods, our experiments, and our apparatus, according to the continually changing conditions of the profession. In order that the Guilds Institute should fulfil its aim, it is absolutely necessary that its teaching should keep pace with industrial progress. Now, even if it were possible for outside examiners, with fixed scholastic notions, to aid in securing this result, would not their efforts be superfluous? for are there not *you*, the employers of labour, to ultimately decide whether the human tool we fashion is, or is not, adapted to your requirements?

Leaving now the consideration of the direct work of the City and Guilds Institute, including their extended system of technological examinations, at which last year 7322 candidates were examined in 53 different subjects at 245 different places in Great Britain and the colonies, the indirect results that have proceeded from the initiative of this Institute are even greater. For, while twelve years ago, education in applied science in this country was a tender little infant, requiring much watching and support, combined with constant encouragement, to-day Technical Education—with a capital T and a capital E, bear in mind—is a stalwart athlete, the strong man on the political platform, exercising the minds of county councillors, and actually regarded as of more importance than the vested interests of the publican.

Until quite recently it was the technical education of the young engineer that had to be considered; but now the problem has become a far wider one, for the education of the British workman is being vigorously pushed forward, and I think that it has become incumbent on you—the representatives of the electrical profession—to express your decided opinion as to what this education of the electrical artisan ought to be.

The technical education snowball set in motion twelve years ago by the City Companies has been rolling—nay, bounding forward—so swiftly during the last year or two that probably some of you have hardly followed it in its rapid growth, both in size and speed. £30,000 has been spent on the Polytechnic in the Borough Road; the Charity Commissioners have already endowed this school with an income of £2500 a year, and it is hoped that before the building is opened, this income will have been doubled. £50,000 has been already promised for the Battersea Polytechnic, the Charity Commissioners having also undertaken to provide this technical school with an income of £2500 a year as soon as the subscription reaches £60,000; and for the establishment of a polytechnic in the City, £50,000 has been set aside out of the funds of the Charity Commissioners, as well as a yearly grant of £5350. Finally, not to speak of polytechnics in North, South, East, and West London, Mr. Quintin Hogg has himself spent £100,000 on the Regent Street Polytechnic, while the Drapers' Company have alone given £55,000 to the technical department of the People's Palace at Stepney, and endowed it with an income of £7000 a year. And, most recently of all, the Goldsmiths' Company have put on one side nearly a quarter of a million sterling for the land, the buildings, and for an endowment of £5000 a year in perpetuity, for their Technical and Recreative Institute recently opened at New Cross.

The following table gives an idea of the sort of sums that are being spent on polytechnic education in London, but it does not profess to give the entire amounts that have been devoted to capital expenditure and yearly maintenance, even for the six polytechnics named in the table:—

CAPITAL EXPENDITURE.		YEARLY ENDOWMENTS.	
<i>Polytechnic, Borough Road.</i>			
Already spent ...	£30,000	Charity Commissioners alone ... ..	£2,500
		(Endowment expected to be doubled before opening.)	
<i>Battersea Polytechnic.</i>			
Already subscribed	£50,000	Charity Commissioners alone ... ..	£2,500
<i>City Polytechnic.</i>			
Charity Commissioners alone to spend...	£50,000	Charity Commissioners alone ... ..	£5,350

<i>Regent Street Polytechnic.</i>	
Spent by Mr. Quintin Hogg ... .. £100,000	Charity Commissioners alone ... .. £3,500
Spent by Charity Commissioners ... .. 11,750	
<i>People's Palace, Mile End Road.</i>	
Given by Drapers' Company alone ... £55,000	Drapers' Company alone £7,000
Given by Charity Commissioners alone 6,750	Charity Commissioners alone ... .. 3,500
<i>Technical and Recreative Institute, New Cross.</i>	
Given by Goldsmiths' Company ... .. £70,000	Goldsmiths' Company £5,000
(Representing a total expenditure of nearly £250,000.)	
Other contributions to polytechnics in London by Charity Commissioners ... £6,000	Yearly endowments of Charity Commissioners to other technical institutions in London ... .. £3,200

*Totals from the above sources alone :*

£379,500	£32,500
----------	---------

Large as are these sums, they are, however, even small compared with the amount raised by Mr. Goschen's beer and spirit tax, which it has been decided shall be used for the public benefit, and not for the benefit of the publican. The counties and county boroughs of England now receive nearly three-quarters of a million sterling per annum, of which the whole may be devoted to technical education. The majority of the counties and county boroughs propose to utilize this magnificent opportunity and devote to technical education the entire sum allocated to them, while the remainder use at least a part for this purpose. Middlesex and London, however, stand alone, and employ their whole yearly grant of £163,000 for the relief of the rates, on the plea that they consider that the City Companies are well able to look after the technical education of London.

Besides this spirit duty, 106 towns are levying rates in aid of technical education under the Technical Instruction Acts of 1889 and 1891, the number of these towns having increased by twenty in the last seven months, showing how rapidly is this desire for technical education spreading throughout Great Britain.

In addition to the sums contributed for technical education by the City Companies, collegiate bodies, and private persons who have the practical education of the nation at heart, the following represent, as far as I have been able to ascertain, the amounts that it has been already decided shall be *actually* spent, *yearly*, on technical education in England alone, exclusive of Scotland, Ireland, and Wales :—

Received from the Customs and Excise duties ...	£500,000
"    "    Rates ... ..	18,046
Given by the Charity Commissioners ... ..	20,550
	£538,596

The yearly amount that will be actually raised under the Technical Instruction Acts will be far larger than the £18,046 stated above, for this represents only the sum of the amounts raised in the very few towns who have already made returns.

*Hence the total sum to be spent in England alone on so-called technical education amounts to certainly over £600,000 per annum.*

As the teaching of electrical technology has been started, in some form or other, in nearly every important town in Great Britain, there is no occasion for me to advocate, as I did in this room ten years ago, that a student of electrical engineering should have an education in applied science; but what I desire to most strongly urge on you to-night is, that it is your bounden duty to see that some portion of the vast sum that is about to be spent on the education of the people is used to give such a training to your workmen as shall really benefit your industry. For otherwise there is a great fear that most of the money devoted to electrical teaching will either be frittered away on the natural loadstone, rubbed amber order of instruction so dear to

the hearts of the school-men, or on semi-popular lectures describing in a bewildering sketchy fashion the whole vast field of electrical engineering.

The workmen you employ are of two classes. In the one class is the man who is all day long, say, stamping out iron disks for armature cores, and the boy who, say, feeds the screw-making machine with its proper meals of brass rod. For such work no technical education is necessary; the workers are mere adjuncts to the machines, to be dispensed with as the machines become more and more perfect. Hence, unless the machine-minder has the ambition and the ability to rise to some less mechanical occupation, his activity, if any be left him after a hard day's work, had probably better be spent in effort of a lighter and more recreative character than would alone be necessary to make him a higher class of artisan.

For him the polytechnic variety course of instruction is an inestimable blessing, for he can do a little type-writing, learn violin-playing and modelling in clay, attend an ambulance class, recite a poem, and devote the remainder of his leisure to the piano, botany, sanitary science, reading books and learning how to keep them.

His general interests will be roused, the human side of his nature developed, and during the evening at any rate he may forget that he is the slave of the Gramme ring, or the slave of the electric lamp.

No wonder, then, that within two months of the opening of the Goldsmiths' Institute at New Cross 4000 members were enrolled.

But your workmen of the other class must, or at any rate ought to, think. Take, for example, the man engaged in wiring houses, whose work is continually changing, and offering small problems to be solved. Here, common sense—or uncommon sense, if you prefer it—is of great value, and the work, to be good, *must* be done by a man with a knowledge of principles, and not by a mere machine-minder.

Many joints—bad joints—wires laid in cement under mosaic, which cannot be replaced except at vast expense, even although the insulation has rotted away—parquetier floors nailed to insulated wire—switchboards screwed on to damp walls—lamp-holders that only make contact when the lamps are twisted askew—high-class insulated mains terminating in snake-like coils of flexible wire running against metal in shop windows, under shop fronts—heavy Oriental metal lamps hanging from lightly insulated cord—all this would be avoided, if the workmen had been taught to use their brains as well as their hands.

Now, do you think that the teaching necessary for this purpose is likely to be given at the ordinary English polytechnic school? In the case of the Goldsmiths' Institute the electrotechnical department has been put under the charge of Messrs. Dykes and Thornton, two diploma students of the Central Institution; and the fact that these men are, in addition, both employed in Messrs. Siemens's works at Charlton leads one to hope that their teaching, at any rate, will breathe the spirit of the factory. And therefore, if ample funds be forthcoming for keeping the apparatus at New Cross always up to date, so that the meters, the models, the dynamos—not merely now at the start, but three years hence, six years hence—are truly representative of the industry, there will be a fair prospect that the electrical department of the Goldsmiths' Institute, although but a fraction of the whole undertaking, may really benefit the electrical workmen in the East End of London.

But my colleagues and I view with considerable apprehension the way in which the present wide demand for teachers in technical schools is being supplied. Several of our own students, for example, tempted by the comparatively high remuneration that is offered, have become teachers in technical schools immediately on leaving the Central Institution. In many respects they are undoubtedly well qualified; but if they had first spent some time in works before attempting to teach technical subjects, they would have better understood the wants of the persons whom they have undertaken to instruct.

No greater mistake can be made than to think that a student who has distinguished himself at a technical college can dispense with the training of the factory, unless it be the opposite mistake of imagining that the factory training is equivalent to or even something better than that given at a modern school of engineering.

It is the province of the manufacturer to turn out apparatus and machinery as quickly, cheaply, and as well made as is possible; it is the province of the technical teacher to prepare

the human tool for subsequent grinding and polishing in the works.

And this necessity for the teacher having himself passed through the shops has especial weight when we are dealing with the technical instruction of workmen, for in such a case there are three requirements absolutely necessary: first, knowing how to teach; second, possessing a fair knowledge of scientific principles; and thirdly—and this is, perhaps, the most important of all—knowing exactly what it is that the particular workman ought to learn in order to help him in his particular trade.

Schoolmasters may have the first two requisites, and so may do valuable work in connection with the variety teaching at a polytechnic; but they are not in touch with the workshop, and therefore, no matter what may be their scholastic attainments, no matter what the extent of their experience in training the young, they are not the persons to give the real technical education to workmen.

In addition, then, to the polytechnics, we must have special schools for special industries, where workmen are taught the application of science to their special trades; and everything taught in such a school must be taught as bearing on the particular industry which the school is intended to benefit. A teacher of physics, for instance, must remember that he is not training physicists, but workmen whose use of physical principles will be bounded by their application to their special trade. For the great danger of such teachers is that, carried away with enthusiasm for their own subject, they will not subordinate it properly to the end in view, viz. helping the workman to know what will be useful to him in his work.

Indeed, as Prof. Huxley pointed out in his original report to the Livery Companies' Committee, "Success in any form of practical life is not an affair of mere knowledge. Even in the learned professions, knowledge *per se* is of less consequence than people are apt to suppose. . . . A system of technical education may be so arranged as to help the scholar to use his intelligence, to acquire a fair store of elementary knowledge which shall be thorough as far as it goes, and to learn to employ his hands, while leaving him fresh, vigorous, and content, and such a system will render an invaluable service to all those who come under its influence.

"But if, on the other hand, education tends to the encouragement of bookishness, if it sets the goal of youthful ambition, not in knowing, but in being able to pass an examination, especially if it fosters the delusion that brain work is, in itself, a nobler or more respectable kind of occupation than handiwork, and leads to the sacrifice of health and strength in the pursuit of mere learning, then such a system may do incalculable harm, and lead to the rapid ruin of the industries it is intended to serve."

And I venture to think that not merely at technical schools for workmen, but at technical colleges for engineers, it should be ever remembered that the main object of the training is not the cultivation of mental gymnastics, but to enable the student to acquire knowledge and habits which shall be professionally useful to him in after life.

"Useful learning usefully taught" would be no bad motto for technical institutions, seeing that those who favour the compulsory teaching of Greek are apparently willing to accept the converse as the motto for the University. For example, Mr. Butler, in his address delivered at the end of last session at University College, Bangor, said: "We may claim it as a distinction that in the seats of academic learning little or nothing useful is taught"; and in an article in last month's *Fortnightly Review*, congratulating Cambridge on its recent victory over the barbarian, Mr. Bury says quite candidly, "Greek is useless; but its uselessness is the very strongest reason for its being in a compulsory subject in the University course." And he adds, in italics, "For the true function of a University is the teaching of *useless learning*."

A few of the County Councils have realized that the real teaching of the application of science to a special industry, which is what the British workman is so much in need of, cannot be given, as well as a host of other subjects, out of limited funds. For example, Bedfordshire has decided to spend its grant of £4343 mainly on agriculture, market gardening, the straw trade, domestic economy, and industries for women; Cambridgeshire and Cheshire devote themselves largely to the teaching of agricultural pursuits.

But other places aim at issuing vast comprehensive programmes and turning out yearly a mighty array of students, knowing, it may be, the something of everything, but who certainly will not

know the everything of something. For example, the Holland division of Lincolnshire has decided, out of only £2000 a year, to make grants for dairy schools, University extension and art schools, agricultural science, domestic economy, mechanics, commercial subjects, and ambulance teaching; while Bootle, with a yearly expenditure of only the same amount, maintains classes in five commercial subjects, in sixteen science and art subjects, in cookery, wood-working tools, as well as four courses of University extension lectures.

Because a certain building in Regent Street famed for its ghost and its diving bell was years ago named "The Polytechnic," the majority of the new technical institutions which are being established in London at such vast cost are also called "Polytechnics," and will, I fear, give only an English polytechnic course. Now, such recreative education, although admirable for those who seek relief from work in the use of their minds, is not generally sufficient for those of your workmen who use their minds in their daily occupation.

It ought, then, to be thoroughly recognized that there is an entirely new problem to be solved, and that the solution of this problem, in so far as it has been worked out at the Finsbury College and at other places giving practical teaching in the evening, must, in the language of the mathematician, be regarded simply as "the singular solution," and not the general solution, of the problem of technically educating the British workman.

Let us gratefully accept the English polytechnics, for they will undoubtedly confer benefit on our country, and all credit be to those who have so generously established them. But do not let us be misled by the similarity between their generic name and that of the German "polytechnicum" into fancying that the recreative courses of the one are equivalent to the serious education given by the other.

Like Oliver Twist, let us ask for more; for, on behalf of the large number of minds already employed in the electrical industry, and on behalf of the still larger number that will in the future be so employed, it is our duty to secure that ample provision be made in this country for the practical teaching of electrotechnics on a scale comparable with that afforded in the technical high schools of Germany and the institutes of technology of the United States.

On the screen you see projected a photograph of the *façade* of the Technical High School at Charlottenburg (Berlin), which appears extensive and grand; and yet, as you will see from the next photograph, it was only a small portion of the whole building that you were looking at on the first photograph. This is but one of the many technical high schools in different towns of Germany, and yet it covers an area more than five times as large as that occupied by the Central Technical Institution in Exhibition Road, London, cost four times as much to erect, and has more than four times as much spent on its yearly maintenance.

The next photograph shows a building devoted wholly to the training of electrical engineers, being that of the Electrotechnical Institution Montefiore at Liège, which Prof. Gerard kindly took me over this last summer, and which has since been opened. When I tell you that there are rooms for small direct-current dynamos, separate rooms for large direct-current dynamos, separate rooms for alternators, and that every three students have a separate little laboratory, with the necessary measuring instruments, all to themselves, your educational mouths will water, as mine did.

We now cross the Atlantic to the Massachusetts Institute of Technology, Boston, which, as you see, consists of several distinct buildings, the centre one being that which contains the electrical laboratories. The dynamo room now seen on the screen has many small and large dynamos in it, and yet there is ample room to walk about, for this dynamo room occupies a space many times as large as that devoted to dynamos at the Central Technical Institution of London.

Prof. Cross was so good as to mention in a letter that was shown me some two years ago, that several of the devices that had been worked out for the electrical laboratories of the City and Guilds Institute had been reproduced at Massachusetts; but there is one device that Prof. Cross has succeeded in working out, and which I should be most glad to see copied by the City and Guilds Institute, and that is, having one assistant for every five students working in the physical laboratories.

Franklin Hall, presided over by Prof. Nichols, is devoted solely to the department of pure and applied physics at the Cornell University, Ithaca. You see how large this four-storied

building must be, for look how small the four-wheeled waggon standing in front of it appears.

The next three photographs show some of the provisions made for teaching electrotechnics in Franklin Hall; the electrical laboratory, under Prof. Moler; and the dynamo room, under Prof. Ryan, whose analyses of alternate-current curves are well known to you all.

I might show you photographs of the electrical laboratories in Prof. Weber's new building for physics at Zürich, on which £100,000 has been already expended. In fact, my choice of magnificent Continental and American laboratories has been so great that I have hardly known which to select as specimens.

But there is one thing I cannot show you—and it must remain for the exercise of your influence as representatives of the electrical profession to make that possible—the British electro-technical laboratories for education and research which are truly worthy of London, the capital of the world.

The training of such students as those at the Central Institution must, of course, differ essentially from that of the electrical artisan, not because we, or the students, expect that on entering a factory at the conclusion of their college course they will start, as a rule, much above the bottom of the ladder, but because they hope in time to be able to mount higher.

They are therefore taught, not merely to construct meters and motors, use dynamos and engines, build a chimney and lay a street main, but, as they are not to spend all their lives wiring houses or watching a central station voltmeter, they are well practised in calculating and designing, and they further obtain sufficient acquaintance with the methods of attacking new problems not to be daunted when they meet with them in after life.

But so strong is becoming our belief in the value of science to the manufacturer, so anti-classical are some of us growing, that there is great risk that the literary side of the education of an electrical engineer will soon be wholly neglected. Now, important as it no doubt is for him to be quite at home with electrical apparatus and machinery, it is no less important, if he is to take advantage quickly of the progress made abroad, that he should be able to read a German or a French newspaper. I do not merely mean that with a grammar and dictionary, and plenty of leisure, he should be able to translate the newspaper, sentence by sentence, like a schoolboy preparing to-morrow's lesson, but that he should have the power to glance down the columns, gather the gist of the articles, and quickly see whether there be anything new that especially concerns him.

How many electricians are there in this country who can, for example, take up the *Zeitschrift für Instrumentenkunde* or the *Electrotechnische Zeitschrift*, and look through their pages as they do those of the *Electrician*, *Electrical Review*, and the *Electrical Engineer*, during breakfast on Friday morning? There are, I know, a few—I wish I were one of them.

And yet examples are not wanting of the scientific isolation that is caused by not possessing that familiarity with foreign languages which is a characteristic of diplomatists and hotel waiters. Take, for instance, the fact that, whereas manganin was manufactured on a commercial scale in Germany, and German resistance coils have for the last three years been constructed of this material with a temperature coefficient of nearly zero, the very existence of this alloy was unknown to many English electrical instrument makers a few weeks ago; and even now most of them are still unacquainted with the composition of manganin, and its peculiar properties, as well as with the results of the extensive and striking experiments that have been carried out at the Reichsanstalt at Charlottenburg on the temperature coefficient and specific resistance of all sorts of manganin-copper-zinc-nickel-iron alloys.

This Physikalisch-Technischen Reichsanstalt, I may mention, is an establishment totally distinct from the Technical High School in Charlottenburg, some photographs of which I showed you this evening. The Reichsanstalt is not an institution with students, but a vast series of Imperial laboratories, presided over by Prof. von Helmholtz, solely used for carrying out researches in pure and technical physics. The investigations are conducted under the direction of Dr. Loewenherz, aided by 46 assistants.

We have no establishment in Great Britain at all comparable with this Reichsanstalt. The original work turned out there in electro-technics alone is considerable. Here are some of the published accounts of researches immediately bearing on your profession which Dr. St. Lindeck has been so kind as to send me: "Hardening Steel Magnets," "Standard Resistance Coils

for Large Currents," "Tests of Commercial Ammeters and Voltmeters," "Mercury Standard of Resistance," "Photometric Investigations," "Compensation Apparatus for Use in P.D. Measurements," "Alloys for Resistance Coils," and so on.

Surely it is part of the technical education of the electrical engineer to be taught how to read such pamphlets as these with comparative ease?

A working knowledge of French and German can be obtained without the necessity of learning to express oneself fluently in epigrammatic French, or to imitate with facility the word-building of a native German; and with such a working knowledge the average technical student may rest content. But as regards his own language he should aim at something higher, and therefore the electrical engineering students of our country should be, I urge, practised in writing—yes, and also speaking—vigorous English.

Only the other day, Prof. Nichols, of the Cornell University, was deploring with me the rarity of finding a student of electro-technics who could write a decent report. The experimental methods employed in the student's investigation might have been good, the mathematical analysis suitable, and the calculations exact; but the description of the apparatus and of the results obtained would be scattered pell-mell over the paper, as if the writer were quite ignorant of the fact that the style in which a dish is served up is nearly as important as the goodness of its ingredients.

Why do you suppose that Huxley's portrait has nearly as much prominence given it in the photographer's window as that of a duke or a ballet dancer? Quite as much because he knows how to express himself in terse and forcible English as on account of his wide scientific knowledge; because even when writing about dry bones the flow of his language clothes them with rounded forms.

But, you will ask, how are we to find the time for all this linguistic and literary polish? Has the electrical student of to-day so many spare hours that fresh subjects of study must be sought for to fill up his leisure moments?

At present much time has to be wasted at technical and other colleges teaching students sixteen years or older elementary mathematics and science, which ought to have been mastered before that age. When the education of childhood is improved, when the higher education of women is properly carried out, there will be no need for male experts to trouble about general training, for then children will spend less time at school and learn more; boys and girls will, as a matter of course, acquire the foundation of modern languages and general education; and students at a college will be able to devote their whole time to the special training—scientific, manual, linguistic, and literary—which pertains to the particular profession which their special tastes will generally have led them to select before the age of sixteen.

And just as methods of teaching applied science have been developed during the past few years, so I look forward to the growth of new methods of teaching what may be called applied literature. For it seems to me that there is a want of breadth in the view that because the study of Greek verse would be unprofitable for a student of electrotechnics, and because he has neither the taste nor the time to enter into the intricacies of etymology and grammar, therefore the study of modern languages and literature, even as directly applicable to his profession, should form no part of his regular training.

As well might it be thought (and I am sorry to say this view is not yet quite exploded) that because a student has neither the taste nor the time for the study of abstract mathematics, therefore he should be debarred from all work in a physical laboratory. Well, if it be generally accepted that although a young electrical engineer has no chance of becoming a Cayley or a Maxwell, still he ought to be taught such portions of mathematics and physics as will be directly useful to him in his profession, why should the certainty that he will neither become a Jebb nor a Dickens lead us to tolerate an inability on his part to speak fluently and write tersely his own language, surpassed only by his entire ignorance of every other?

Habits of scientific thought are highly necessary for electrical students; to be masters of their own language, and to know something of one or two others, are, I venture to think, no less so; but the main result to be achieved, the main object to be aimed at, with every system of education, is moral thoroughness.

For until every workman, foreman, engineer, and manu-

facter feels regret and pain at seeing work inefficiently performed, our national system of education will be incomplete.

All the labour now expended in watching work in progress, and in testing it when completed to see that it has not been scamped, is so much withdrawn from the real business of production. Every rise, therefore, in the standard of thoroughness of a community means the saving of waste labour. But far greater than this will be the actual increase in the productive power when each gives his best endeavours to his share of the world's work. And greatest of all will be the gain in the nation's happiness, since he who works with his whole soul knows no drudgery.

The lesson to be taught is no new one—it was set many centuries ago; and hundreds of thousands a year will be well spent if the County Councils can succeed in bringing home to the hearts of us all this—"Whatsoever thy hand findeth to do, do it with thy might."

### PHOTOGRAPHY AS A BRANCH OF TECHNOLOGY.<sup>1</sup>

THE invitation conveyed to me by your Council, to assist in promoting a scheme of photographic technical education of a more complete character than that provided by the elementary schools, is in such complete accord with the principles which I have always held, and which I have occasionally promulgated through other channels, that I felt it an almost imperative duty to respond to the invitation in spite of the numerous other claims upon my time. For I believe that if the Photographic Society will throw itself with zeal into some well-organized scheme in this direction a great benefit will be conferred upon the cause of technical education in this country. I will even go so far as to express the belief that a work of national importance may be accomplished.

It may perhaps appear as preposterous to dwell upon the importance of photography before the members of this Society as it would be for a merchant to address the Chamber of Commerce on the importance of trade, or for a financier to lecture to an Institute of Bankers on the importance of banking. Nevertheless, it is a common experience that those who are actively engaged in the prosecution of some special kind of work often take a narrow view of their own labours; they have no time to take a bird's-eye view of the whole subject, and an independent outsider may sometimes do good service by gathering up the odds and ends of scattered observations and fitting them into their right positions in the general plan. If any justification is required from me for addressing a Society composed so largely of photographic experts, I need only plead that as a teacher of technical chemistry I have felt it necessary to give full recognition to the claims of photography as an important branch of technology. It can no longer be ignored that photography has penetrated the arts and sciences to an extent that has raised it to an exalted position among technical subjects, and as such it has not yet received its proper recognition in this country. From the very dawn of its discovery the importance of its applications was foreseen, although it is only in our own time that the realization of this importance is being witnessed. We need not commit ourselves to the extravagance of Paul Delarocche, the artist, who, during the excitement caused by the revelation of the Daguerreotype process, is said to have declared: "Painting is dead from this day!" The art of the painter has not been killed, but it may fairly be claimed that it has been aided by photography; the art of the engraver has been revolutionized by its means. The prophetic utterance of a writer in the *Edinburgh Review* for January 1843 has been fulfilled:—

"The art of Photography or Photogeny, as it has been called, is indeed as great a step in the fine arts as the steam-engine was in the mechanical arts; and we have no doubt that when its materials have become more sensitive, and its processes more certain, it will take the highest rank among the inventions of the present age."

All who are familiar with modern photographic methods will admit the truth of this prediction; the materials have been rendered more sensitive and the processes more certain. The sensitiveness has been increased to a degree that would probably astonish the writer of the passage quoted, and the

certainty of the processes is such that the amateur photographer exists by thousands. It is perhaps this last circumstance which is responsible for the identification of photography in the public mind with the taking of portraits and landscapes. These are no doubt very important applications of the subject, but photography is not synonymous with portraiture and the taking of scenery; if we allow this view of the subject to prevail, it cannot but have the effect of narrowing down the general estimate of its importance, and of thus injuring its claim to take high rank among technical subjects. We are here, I imagine, to proclaim the far-reaching importance of our subject. Everyone knows with what beautiful effect the photographer can reproduce a portrait or a piece of scenery, but what is not so generally known to the public at large is the enormous service that photography has rendered to other branches of science. If I dwell therefore upon this application of the subject, it is not for the purpose of depreciating its application to art, but rather for the purpose of exalting both aspects.

The modern dry plate has insinuated itself into every branch of practical science; whenever a phenomenon of a temporary character has to be registered with absolute accuracy—where the human eye fails, owing to the faintness of the object, or the rapidity with which the phenomenon occurs, there the aid of the dry plate is invoked. The application of photography to astronomy has, as is well known, relieved the eye of the astronomer and curtailed the work of the observatory to an extent bordering on the marvellous. A faint nebula, which by eye observation may take many years of wearying labour to represent in the form of a drawing, in the course of a few hours impresses its image in all its fineness of detail on the photographic plate—a memorial for future ages of the true form of the nebula at the time of its being photographed. Stars which appear as points of lights in the telescope are shown by the photographic plate to be small nebulae, and stars and nebulae which have altogether eluded the most powerful telescopic search impress themselves on the sensitive film. All this and much more in the same direction is such familiar knowledge now that it is only necessary to mention the facts, nor need I remind you how the photographic plate is being utilized for the photo-astrographic survey of the heavens, and in astronomical spectroscopy for the permanent registration of the solar spectrum and the spectra of the stars. The "Draper Memorial" is one of the latest examples of the utility of photography in the observatory; it is no exaggeration to say that one of the grandest problems of modern science—the question of stellar evolution—will be rendered capable of scientific discussion by this application of the gelatino-bromide film. The modern astronomical observatory is in fact equipped for photographic work quite as much as for observational work, and the photographer has become as necessary as the observer.

In physics and in chemistry also the photographic plate has been added to the weapons of research. Here it has been used to record phenomena which occur with such rapidity as to elude visual perception. What would the *Edinburgh Reviewer* of 1843 have thought of the possibility of photographing a soap film in the act of breaking, or a liquid drop in the act of falling? Yet, as you all know, Lord Rayleigh and Mr. Boys have succeeded in doing this. Or take again the application of the sensitive plate to the elucidation of the phenomena of gaseous explosions by Prof. Oettinger who, by using a rapidly rotating dry plate, was enabled to show the intermittent character of the flash produced by the explosion of hydrogen and oxygen. Profs. Living and Dewar have also succeeded in photographing the spectrum of a mixture of exploding gases. In spectrum analysis, in fact, the services which have been rendered by photography cannot be over-estimated. The astronomer, the physicist, and the chemist must have for reference complete and accurate charts of the spectra of the chemical elements. The early maps of Bunsen and Kirchoff, and the splendid "Spectre Normale" of Ångström were drawn by eye observation after years of laborious work, and with injury to the eye-sight of the observers. These maps are now produced by photography without any tax upon the eyesight, and with an amount of detail that renders the early maps—executed with such painful labour—but mere skeletons as compared with their photographic representatives. The spectra can moreover be compared far more readily and with much greater accuracy by the photographic method. The method of eliminating the lines in the spectrum of one element, due to the presence of a trace of some other element as an impurity, which we owe to Prof. Norman Lockyer,

<sup>1</sup> An Address to the Photographic Society on February 2, by Prof. R. Meldola, F.R.S.

has only been rendered possible by photography. If the residual lines common to several elements, and which cannot be traced by this means to any known element, should lead to the discovery of new elements or to the resolution of known elements into simpler forms of matter, the credit must be given to the photographic method.

But it will be safer to confine ourselves to what photography has actually done for science than to attempt to enter the regions of speculation. The case to be made out is such a good one that there is no need to draw upon the imagination. Thus, again in the region of spectroscopy, the relationship between the constitutions of chemical compounds and their power of absorbing certain definite light waves, as investigated by Prof. W. N. Hartley, may be said to have been discovered by means of photography, because the absorption is, in the case of colourless liquids, exerted beyond the limits of the visible spectrum. In meteorology the photographic plate has also been of the greatest service, and a British Association Committee has been formed for the purpose of stimulating work in this direction. Most of those present are, no doubt, familiar with the more striking results achieved by meteorological photographers. The fleeting forms of clouds can be registered with absolute fidelity, and by an ingenious arrangement of electrically connected cameras the height and rate of motion of clouds has recently been determined by the aid of photography. The character of the electric discharge in the laboratory has been studied photographically by Mr. Shelford Bidwell and by Profs. Oliver Lodge and C. V. Boys, and the large-scale discharge of the lightning flash has been made to impress itself on the photographic plate. The results are known to all; the conventional zigzag "fork" appears to have no existence in nature. The destructive effects of wind storms on buildings can also be studied in photographs with an amount of accurate detail that it would be impossible to represent by any other method; and I am informed by Mr. G. J. Symons that important conclusions concerning the nature of the atmospheric movement have been arrived at by the examination of such photographs.

Passing on to other applications of photography, it is obvious that in geographical and ethnological exploration the camera has become an essential part of the traveller's equipment. In geology again the aid of the photographer has been called in, and with such good results that a British Association Committee has been called into existence, and has been doing excellent work in collecting and registering geological photographs during the last two or three years. In these photographs sections are recorded with a fidelity which it would be impossible to equal except by laborious sketching. Where time is an object, as in the case of sections only temporarily exposed, the camera is invaluable. Moreover, the value of such photographs will increase with time in the same way and for the same reason as photographs of the starry heavens. For while the latter, taken at the time of the present celestial survey, will, by comparison with photographs taken in the far distant future, reveal relative movements among the stars, the geological photographs of the present period will by future comparison with the localities registered furnish incontestable evidence of the slow course of geological change.

In biology photography has been utilized with great advantage, and will no doubt become of still greater service in the future. There is no reason why the dry plate, which has already largely superseded the eye in astronomy, should not also relieve the eye of the microscopist. Many biological works have been illustrated with great success by means of photography, and even in purely systematic works, such, *e.g.*, as Marshall and De Nicéville's "Butterflies of India," photographic illustration has been adopted with success. In studying microscopic forms of life, where an evanescent phase of life-history may be full of profound significance, the photographic plate might well replace the eye in those cases where prolonged and fatiguing observation has hitherto been found necessary. The fleeting phases of expression, of such importance in comparative psychology, have been caught and fixed on the photographic plate with a natural fidelity that it would have been impossible to attain without such aid. Mr. Darwin's work on "The Expression of the Emotions" was, as you are aware, illustrated by photography even before the dry plate had been worked up to its present exalted degree of sensitiveness.

The application of photography to the analysis of the movements of animals has been made familiar through the remarkable photographs which Mr. Muybridge has on many occasions

brought under our notice in this country. Among other results recently achieved, I need only refer to those wonderful pictures of animals in motion, taken by Messrs. Marey and Anschütz. Such results as these are not only interesting illustrations of the high state of perfection to which modern photography has been developed, but they are of the highest value in elucidating the mechanism of animal movement, and of the flight of birds. The introduction of photography into this branch of animal mechanics has led to a complete revision of pre-existing conventional notions, and the indirect effect of such photographic analysis of the phases of motion on the work of the artist is of an importance that cannot be over-estimated.<sup>1</sup>

In the department of anthropology photography has served for the faithful registration of race types, and Mr. Francis Galton's method of composite portraiture is familiar to all. In his recent studies of "finger marks" in connection with heredity, Mr. Galton has also found it indispensable to work from photographic enlargements.

This imperfect sketch of the scientific applications of photography might well be followed by a much more extended list of its achievements in the domain of art. But I do not feel myself justified in taking up more time in telling you what you already know, and there are no doubt many present who are far more competent to deal with this aspect of the subject than I am. I cannot help thinking, however, that it would materially help the cause of technical instruction in the desired direction if some competent authority among you were to draw up a complete statement of the benefits which have accrued to art, both abstract and applied, by the introduction of photographic and photo-mechanical methods.<sup>2</sup>

To all who are interested in the advancement of art and of science, photography appeals, therefore, as a branch of technology of the first order of importance; in saying that it appeals to art and to science for such recognition, it is evident that it appeals to the nation at large. Even to the "pure scientist," who is supposed to lose interest in a discovery as soon as it becomes practical, *i.e.* commercial, this subject appeals for support, for from the study of the photographic processes themselves many important contributions to physics and chemistry have been made, and still greater results may be expected to follow from the investigations of scientific men in this direction. From its purely practical side the claim of photography to be considered as a branch of technology will receive additional support when it is remembered how many distinct branches of manufacture it draws upon, or has, indeed, actually called into existence. Consider how it is dependent on the optician for the manufacture of lenses; consider, again, the special branch of cabinet-making and joinery which it has created in order to supply cameras and other instruments; remember, also, the boom which photography has conferred upon the chemical manufacturer by the demand for fine chemicals which it has created. Neither must it be forgotten that a new and by no means unimportant development in the manufacture of paper, gelatine, and albumen has arisen through the introduction of photography.

From every point of view, therefore, photography claims to be placed on the same basis as other branches of technology. The Photographic Society, I am happy to see, fully recognizes this in the recent action which it has taken, and which is expressed in the report of the Affiliation Committee. I consider this an excellent move in the right direction. But it is easy enough for the Society to recognize the technical importance of its own subject; the difficulty is to move public opinion, and to convince the nation that we are behind other countries in this respect. The first step is to draw up and circulate widely an account of what is being done for photographic technical instruction on the Continent. I had intended when first invited to lecture here, to offer some such statement, but I was glad to read in a recent number of your *Journal* that this task had been undertaken by Mr. Warnerke, and I hope that some means will be taken to bring his report under the notice of those interested in technical education. It is clear from what has already been attempted by this Society, and from the opinions which have been expressed on all sides by those whose voices carry the weight of authority, that nothing short of a Photographic Institute will meet the requirements of the case. This I most

<sup>1</sup> Prof. du Bois-Reymond deals with this in the address referred to. Some of Prof. Marey's recent results are described in *NATURE*, vol. xiv. p. 228.

<sup>2</sup> Since the above was written Prof. E. du Bois-Reymond's address to the Royal Academy of Sciences of Berlin on the "Relation of Natural Science to Art," has appeared in *NATURE*, vol. xiv. pp. 200 and 224.

earnestly hope will be the end and aim of every movement made by the Society. In the Cantor Lectures, which I had the honour of delivering before the Society of Arts in the spring of last year, I alluded to the absence of such an establishment in this country as "remarkable"; before this Society I am tempted to express myself more strongly, and to stigmatize its absence as a national disgrace.

Of course we all have more or less distinct ideas of what the functions of such an Institute would be. It is premature as yet to speak of the details of an institution which exists only in our aspirations. But whatever may be the final outcome of the movement which has been started, the whole duty of such an institution might be summarized in the statement that its work would consist in spreading a knowledge of all that is known concerning photography, and in investigating that which is unknown. In other words, its duties would be, as in the case of kindred institutions, teaching and investigating. Without wishing in any way to intrude my opinions into the deliberations of your Council, I thought that I might with advantage avail myself of the present opportunity of submitting my own views with respect to this question of technical education in photography. In giving expression to these views I have in mind the consideration that the remarks which I may apply to our special subject apply to many other related technical subjects, and that the course which may be adopted in the starting of such an Institute as that which we all wish to see come into existence, may have a wide and important influence on existing notions concerning the whole question of technical education.

In the first place, then, let me express the hope that any action taken by this Society in the direction of photographic technology, will be of the highest possible character. This may appear to you quite an unnecessary caution, but it involves a question of principle which it is very important to ventilate. After many years of apathy in this country, and after experiencing the inevitable consequence that we were being beaten in many branches of applied science by our Continental competitors, we underwent a few years ago a kind of revival in technical education. One outcome of this agitation was the foundation by the City and Guilds of London of that Institute in whose service I have the honour of being employed. It is not for me to dwell upon the results which have flowed from the inauguration of that Institute, but it is no exaggeration to say that the wave of public opinion which raised it into existence is still surging throughout the country. The last decade has witnessed the rapid multiplication of technical classes and colleges, the foundation of technical associations, the growth of polytechnics, and last of all, the diversion by the Government of the funds derived from the beer and spirit duty in the direction of technical education. The result of all this is that the means of technical education are being spread broadcast throughout the land.

Now it is one of our national characteristics that when we once wake up to the circumstance that we are behind other countries in any matter affecting our industries—or, I might say, when we have this unpleasant truth brought home to us by the superior workmanship or lower prices of our competitors—we are apt to seek remedial measures to recover our lost ground by what might be called indiscriminate and impulsive rushes. I am afraid that the technical education movement has, to some extent, been of this impulsive character. I am not going to be rash enough here to attempt to lay down any precise definition of what is meant by technical education; but a few months ago, the Duke of Devonshire, then Lord Hartington, made a speech at the opening of the Storey Institute, at Lancaster, in the course of which he said that technical education was not the teaching of any particular trade or handicraft, but rather the scientific principles underlying the trade or handicraft. I think this fairly represents the opinions of those who have considered the subject, and I hope that this definition will be borne in mind in any movement which this Society may inaugurate.

If now we review the situation, it will appear that the general spread of this educational movement may be taken as an indication that we intend to give battle to our competitors, and that we look to technical education to enable us to carry on the industrial campaign. So far so good; but our competitors, be it remembered, have been actively carrying on this branch of education during our long years of apathy. We have taken up our weapons rather tardily, and, as I just said, somewhat impulsively, and if we hope for success it behoves us to examine these weapons critically, in order to make sure that we are fighting on equal terms. In other words, are we adopting the

best methods of technical education? This is the question which should be put in the foremost place before any measures can be taken by this Society in the much needed direction of photographic technology.

So far as concerns those technical subjects in which, as in photography, chemistry is largely, if not entirely, the underlying science, I am bound to confess that the impulsive character of the technical education movement to which I have referred, may, if not properly directed, run us altogether off the right track. One of the greatest functions of this Society would be to prevent such a calamity by diverting the tide of public opinion into the proper channel for its own particular subject of photography. The ideal technologist is a man who possesses a good general knowledge of the principles of those sciences underlying his industry, together with an expert special knowledge of his own subject. The first step in the training of a technologist is, therefore, to lay the broad foundation of general principles, and then to erect upon this foundation the superstructure of special knowledge. You must understand that I am attempting only to define an ideal technical training, having more especial reference to those subjects connected with, or based upon, chemical science. In the present state of affairs it cannot be denied that there are large classes to whom this method cannot be applied; there are specialists in every industry who know little or nothing of the scientific principles underlying their occupation, and in such cases the method may have to be reversed, and the instruction may have to proceed from unscientific specialism to scientific generalisation. But this method is, in my belief, only a makeshift which it may be expedient to adopt to meet existing conditions—it is not technical education in the strict sense of the word education, but the tinkering up of a system which has been bad from the beginning. It is only when we can deal with the student just starting on his career as a technologist that the true method can be applied; as things are we have many years of tinkering work before us, and it is to the rising generation of younger technologists that the future industrial welfare of the country is committed.

The danger ahead which threatens the true cause of technical education appears to me to be this:—The resources of the country are being too much frittered away in the multiplication of machinery for imparting elementary instruction, and the higher specialisation which alone will save us in the end is being crippled thereby. The elementary groundwork must be laid, and this work, as far as it is being done, cannot be done too well. But it is absurd to suppose that we shall recover our lost position in any branch of industry by scattering broadcast a knowledge of elementary science, and there leaving matters to stand. A technologist is nothing—at least in any of the subjects with which I have had connection—unless he has the means of superadding more advanced specialisation to his general grounding. So far as the chemical industries of this country are concerned, a few highly-trained specialists are worth more than an entire army of elementary certificated teachers or prize-winners. We are expending so much energy over our foundations that there is but little left for raising the superstructure. We are arming our industrial fighters with weapons which are as pop-guns compared with the heavy ordnance of our competitors. Unless those who are responsible can be made to see that the elementary training in general principles is, in a large number of subjects, quite useless unless the higher specialization is equally well catered for, we shall be no better off in these branches of technology than we were before. The elementary training bears to technology the same relationship that the tuning of the instruments does to the overture. There is a great deal of twanging and blowing going on all over the country, but, as yet, comparatively few indications of a finished performance. There is enough money in the hands of the County Councils at the present time to support technical institutes adapted to local requirements on a scale which would bear comparison with the polytechnics and technical high schools of the Continent. If each county, or group of counties, had its central technical institute, manned by competent specialists, then the elementary training might bear real fruit, and we should look forward with greater hope to the result of the campaign on which we have entered. It is not difficult to see how the fight will end if we persist in blazing away with this elementary small shot in response to the ponderous missiles of our industrial competitors.

Out of the haze of generalities which I am afraid I have been

led to inflict upon you, the central idea concerning the proposed action of this Society I hope begins to loom with a more or less definite form. It is not for you to add to the general tinkling of small bells, but it remains for you to bring together a strong staff of expert ringers who can give us a good loud peal on the chimes. You will, I hope, sooner or later, set an example in technical education in your own subject—which so admirably lends itself to the purpose—which shall act indirectly on all related subjects, by showing how much of the real work of technology begins after the elementary and advanced training have been completed. The instruction imparted under the existing arrangements is good as far as it goes, but from your point of view it must be regarded as the means of supplying the raw materials out of which the technologist of the future is to be moulded. It is not your province to assist in the multiplication of elementary classes, but to set the seal of efficiency on the existing organizations.

I should have but little justification for addressing you as I have did I not feel what a splendid opportunity lies before you for raising the level of at least one important branch of technology. Still less should I be justified in responding to your invitation did I not offer some suggestions which may be of use in furthering your object. The Photographic Institute, such as we desire, would be an establishment thoroughly equipped for the best practical instruction, well provided with appliances for carrying on research in every department of the subject, and having attached to it the most competent specialists in every branch. The staff need not be numerous at first; a chemist, an optician and physicist, an expert in photo-mechanical processes, and an artist would represent the chief departments. Your committee or governing body would know the right men to select; if they cannot be found in this country you may have to go abroad for them. This course may appear ignominious, but if it has to be adopted so much the better; it will bear practical witness to the necessity of having the means of raising such men in our own country. The ideal institute may be a slow growth, but every effort should be made to establish it. The Photographic Society has already taken the initiative by proposing an affiliation with kindred Societies. This scheme should be energetically pushed forward, and every means adopted for urging the importance of the claims of photography to have a recognized technological centre. I venture to think that an impetus would be given to the movement if representatives of the Camera Club, the Photographic Convention of the United Kingdom, and of the numerous photographic Societies of the metropolis were invited to another conference, such as was held last year, but with the special object of forming a joint committee, under whose authority a further appeal might be made for public and private support. If only a moderate fund could be raised at first, operations might be commenced. Surely the numerous firms which have come into existence through the general introduction of photographic processes, and the large body of wealthy amateurs who practice the art as a pastime, might be sufficiently interested in the movement to give it their support.

It only remains now to bring these suggestions to a practical issue. We are such a very practical nation that unless something tangible is offered, the foundation of the Institute may be indefinitely delayed; as yet there is nothing of the kind in existence—there is no organized work being done that appeals directly to the patriotism and to the pockets of those to whom you may legitimately look for assistance. But elementary photography is being taught in connection with technical schools and classes all over the country. A good beginning might be made if under the auspices of the joint committee a few first-class specialists were enlisted and authorized to give short courses of demonstrations to those affiliated Societies or in those centres which desired to receive such instruction. The local centres might fairly be asked to make the necessary arrangements and to bear the small expense of local organization; the fund raised by the joint committee would be well spent at first in defraying the costs of a few special lectures. You may have some difficulty in laying your hands on the right men for this work; I need hardly remind you that the whole success of this initial movement would depend upon your sending only the most highly qualified specialists. You must have men who can teach the teachers and convince practical photographers that underlying the practice of their art are broad scientific principles which it is their interest to know something about. These preliminary peripatetic courses must be regarded in the light of missionary efforts, having for their object not the multiplication of photographic operators, but the awakening of the elementary

and advanced student to the higher aspects of their subject. It is desirable to have this function of the lectures well understood at the outset; the experts who are entrusted with this work will know well enough that it is impossible to make a technologist out of a student, however enthusiastic he may be in his subject, simply by giving him a course of lectures.

If the system of itinerant instruction which I have suggested can only be fairly started, even on a small scale, one important function of the Institute will have been inaugurated. It will have a claim upon the practical educationalist as a teaching body; it will appeal more specifically to the promoters of technical education and to those public bodies which have voluntarily or by Act of Parliament identified themselves with this movement. It is certainly discouraging—I may say discreditable—when we see the magnificent scale on which the photo-technical Institutes of Berlin and Vienna have been founded and equipped, that in this country, whatever the importance of the subject, public recognition and support come only after success has been achieved by private enterprise. I am afraid you will have to reckon with this national characteristic, which, although retarding advancement in many directions, is so far good that it calls forth the most strenuous exertions to insure success at the outset of every new movement. Upon the success of your first small undertaking will depend the larger ultimate success which we all look for.

One other suggestion occurs to me which may help to strengthen your hands. I have said that instruction in photography is already being given in many technical schools; this instruction is more or less of an elementary character. It seems feasible to combine with the proposed courses of special lectures a system of inspectorship which might be carried out by the same staff. Your lecturers would be recognized experts, capable of advising such schools as to methods of teaching and of co-operating with local centres in the selection of the most highly qualified teachers. I am sure that most centres would be only too glad to avail themselves of the knowledge and experience thus placed at their service. If you begin operations on these lines at first—if you can carry on this combined system of skilled teaching and inspection successfully for a few years, your claim for permanent establishment and endowment as a Photographic Institute cannot but receive that support from public bodies to which your educational efforts will have entitled you, and which in other countries is given by the State.

#### UNIVERSITY AND EDUCATIONAL INTELLIGENCE.

OXFORD.—*Commencement of Hilary Term.*—The usual notices are being issued this week to undergraduates to come into residence the end of next week, full term commencing February 8. The notices state that Hilary Term will be of the usual length—eight weeks. Residence for Easter Term will begin on April 22. The dates for the examinations in Hilary Term have been fixed as follows: Preliminary in Natural Science, March 14; First Public Examination for Honours in Classics, March 17; Resposions, March 31.

It has been stated that this is the first time the date of the commencement of Term has been postponed by reason of an epidemic since the date of the Great Plague in the seventeenth century, when a whole term was abandoned.

The Senior Mathematical Scholarship has been awarded to Mr. A. E. Jolliffe, B.A., late Scholar of Balliol and Fellow of Corpus Christi; Proxime Accessit, Mr. R. C. Fowler, B.A., of New College, to whom the examiners have awarded Lady Herschel's Prize for Astronomy. Mr. H. H. Piggott, Corpus Christi, was awarded the Junior Mathematical Scholarship; and to Mr. H. A. Pritchard, of New College, the Junior Mathematical Exhibition.

CAMBRIDGE.—Mr. F. W. Dyson, B.A., of Trinity College, bracketed Second Wrangler, 1889, and Smith's prizeman, 1891, has been elected to the second Isaac Newton Studentship, tenable from April 15, 1892, to April 15, 1895.

Mr. J. H. Flather, late Master of Cavendish College, has been appointed Assistant-Secretary for the Local Examinations. An Exhibition of fifty guineas a year is offered by the Clothworkers' Company for proficiency in physical science. It is tenable for three years by a non-collegiate student of Oxford or Cambridge. Application is to be made to the Censor, Fitzwilliam Hall.

An influential syndicate has been appointed to obtain plans



and estimates for the erection of the Sedgwick Memorial Museum of Geology on a site within the Old Botanic area, contiguous to the new Chemical Laboratory.

Dr. Forsyth, F.R.S., is appointed an additional member of the Mathematical Board for one year.

In consequence of the lamented death of Sir George E. Paget, Sir G. M. Humphry and Dr. D. MacAlister have been appointed to act for the Regius Professor of Physic, in reference to Acts for medical degrees during the vacancy in the professorship.

SOCIETIES AND ACADEMIES.

LONDON.

**Mathematical Society, January 14.**—Prof. Greenhill, F.R.S., President, in the chair.—The President drew the attention of the members present to the loss the Society had sustained by the recent death of Prof. Kronecker, who was elected an honorary member on January 14, 1875.—The following communications were made:—The harmonic functions for the elliptic cone, by E. W. Hobson. The harmonic functions for the circular cone were introduced by Mehler; an account of them is given in Heine's *Kugelfunctionen*. In this communication the more general functions are considered, which are required for potential problems connected with the elliptic cone. It is shown that the normal functions are of the form

$$\frac{1}{\sqrt{r}} \frac{\sin(\rho \log r)}{\cos(\rho \log r)} \cdot A(\mu) B(\nu),$$

where  $r$  is the radius-vector, and  $\mu, \nu$  are elliptic co-ordinates, the functions  $A, B$  satisfying differential equations which differ from Lamé's equation only in having  $-\frac{1}{2} + \rho\sqrt{-1}$  instead of  $n$ ; thusthe functions  $A$  and  $B$  are Lamé's functions of complex degree. The forms of these functions as required for the potential problem are considered, and some examples of their application are given.—Some theorems relating to a system of coaxial circles, by R. Lachlan. This paper is based on a suggestion contained in a short note by Dr. A. S. Hart in the *Quarterly Journal* (vol. ii. p. 143), who indicated a simple and elementary method of obtaining Poncelet's theorem. In the present paper this method is discussed in detail. Poncelet's theorem may be thus stated: *If  $A_1, A_2, A_3, A_4, \dots, A_n$ , be  $n$  points taken in order on the circumference of a circle  $S$ , so that any  $(n-1)$  particular connectors of the polystigm  $A_1A_2 \dots A_n$  touch fixed circles coaxial with  $S$ , then the remaining connectors of the figure will envelop circles which belong to the same coaxial system.* If now  $S_1, \nu$  denote the circle which is touched by the chord  $A_1A_2$ , it is proved that if  $(n-1)$  connectors of the polystigm touch any  $(n-1)$  of the circles  $S_1, \nu, S_2, \nu, \dots, S_{n-1}, \nu$ , the remaining connectors of the polystigm will envelop the remaining circles. A few special cases are then discussed, among which the most interesting is the case of  $2n$  points  $A_1, A_2, \dots, A_{2n}$ , taken in order on a circle  $S$ , so that the chords  $A_1A_2, A_3A_4, \dots, A_{2n-1}A_{2n}$  touch another circle  $S'$ : it is then proved that the  $n$  chords  $A_1A_{n+1}, A_2A_{n+2}, \dots, A_nA_{2n}$ , must intersect in a limiting point of the circles  $S$  and  $S'$ , and that the remaining  $2n(n-2)$  connectors may be divided into  $(n-2)$  sets of  $2n$ , each set being tangents to a circle coaxial with  $S$  and  $S'$ . Further, it is proved that the  $2n(n-1)$  connectors which do not intersect in the limiting point may be arranged in  $n(n-1)$  pairs, each pair touching two circles of the system.—Note on the formula for the number of classes of binary quadratic forms of a given determinant, by Prof. G. B. Mathews.—Researches in the calculus of variations (third paper), by E. P. Culverwell.—Mr. E. B. Elliott, F.R.S., made a short oral communication on a generalization of De Morgan's method of duality in partial differential equations. He exhibited schemes of linear substitution for one set of variables in terms of another set of first derivatives, which have the self-dual property, discussing the cases of two and of three independent variables.—Major MacMahon, F.R.S., mentioned the "stamp-folding" problem, at which Prof. Schoute, of Groningen, has been working. For a strip of stamps (one stamp width), the following results, when the strip is folded so that the face (or back) of one stamp only is exposed, were given: (1) = 1, (2) = 2, (3) = 6, (4) = 16, (5) = 50, (6) = 144, (7) = 462, (8) = 1398 (?), (9) = 4527. For squares, the results given were (2) = 8, (3) = 296, (4) = 13007 (?). (9) is found to give more than 2½ billions. The law of formation of the numbers is sought.—Messrs. Basset, Love, Kempe, Hobson, Prince C. de Polignac, and the President spoke upon the papers.

**Linnean Society, January 21.**—Prof. Stewart, President, in the chair.—On a motion by the President, it was unanimously resolved that an expression of respectful sympathy should be conveyed to Her Majesty the Queen, and to H.R.H. the Prince of Wales, on the loss sustained by the death of H.R.H. the late Duke of Clarence and Avondale.—Mr. M. F. Woodward exhibited microscopic sections illustrating the development of the teeth in the Marsupialia. He drew attention to Prof. Kükenthal's recent discovery of supposed rudimentary successors in all the teeth, thus showing that the adult set of teeth must be regarded as belonging to the first or milk series, and not, as generally supposed, to the second or successional dentition. These statements he was able to confirm for the incisors and second upper molar of *Didelphys*. In the Phalanger (*Trichosaurus*) he found no trace of these structures in connection with the molar teeth, but they were present with the upper incisors. In no case did these rudimentary successional teeth pass beyond the condition of simple down-growths from the enamel organs of the functional teeth.—Mr. J. W. Willis Bund exhibited a supposed hybrid between the common and red-legged partridges, but in the opinion of ornithologists present it was regarded as merely a variety of the former species.—Mr. J. C. Mansel Pleydell exhibited a pair of malformed horns of the roebuck found at Whatcombe, Blandford, Dorset, their peculiar growth resulting from exostosis consequent upon injuries sustained while in the sensitive condition.—Mr. D. Morris communicated some further notes upon the tick-pest of Jamaica, upon which an animated discussion took place.—A paper was then read by Mr. F. E. Weiss "on the development of the caoutchouc-containing cells of *Eucommia ulmoides*, Oliver." He found that the bark and leaves of this tree, used medicinally by the Chinese, and called by them "Tuchung," contain numerous elastic threads of silky appearance, which proved to be of the nature of caoutchouc. They are contained in long, unbranching cells, somewhat like latex cells, which are found in the cortex and in the secondary pith, and accompany in large numbers the ramifying bundles of the leaf and the pericarp. Unlike the ordinary latex cells, they are not derived from specialised cells of the embryo, but originate in all new growths, and can be seen forming in the cortex, the pith, and the parenchyma surrounding the bundle of the petiole. They originate in twos, by longitudinal division of a very granular cell, both daughter cells growing out at their two extremities into a long tube, which makes its way along the intercellular spaces by sliding growth. They never contain more than one nucleus, and the large granules of caoutchouc, which soon make their appearance, finally coalesce into a single solid mass, which has, when the tissues are broken, the appearance of a silky thread. Mr. Weiss regards these cells as a primitive form of latex cells, similar to those from which the more elaborate ones of the ordinary *Euphorbia* may have been derived.—The meeting was brought to a close with a paper by Dr. Jean Müller on the Lichens of Manipur.

**Royal Meteorological Society, January 27.**—Annual General Meeting.—Dr. W. Marcell, F.R.S., Vice-President, in the chair.—The Report of the Council for the past year showed the Society to be in a very satisfactory position. In May the library and offices were removed to more commodious premises at 22 Great George Street. After defraying the cost of fitting up the new offices, and the increased rental, there still remained a balance in hand of £224. Thirty-four new Fellows were elected during the year, the total number on the roll of the Society now being 552. Owing to the absence of the President, Mr. Baldwin Latham, through an attack of influenza, his address on "Evaporation and Condensation" was read by the Secretary. The question of evaporation is of as great importance as the study of the precipitation of water on the face of the earth, as the available water supplies of the country entirely depend upon the differences between these two sets of observations. The earth receives moisture by means of rain, dew, hoar-frost, and by direct condensation. It loses its moisture very rapidly by evaporation. Although evaporation mainly depends upon the difference between the tensional force of vapour due to the temperature of the evaporating surface, and the tensional force of the vapour already in the atmosphere, yet it is largely influenced by the movement of the air and by its dryness, or the difference between the dew point and the actual air temperature. Evaporation goes on at night so long as the water surface is warmer than the dew point. With sea-water the evaporation is about 4½ per cent. less than with rain water, while

with water saturated with common salt the evaporation is 15 per cent. less than with rain water. In his experiments Mr. Latham used an evaporating gauge made of copper, 1 foot in diameter, and containing 1 foot in depth of water, which was floated by means of a hollow copper ring placed 6 inches distant from the body of the evaporator, and attached to it by four radial arms. This form of evaporator was found extremely convenient in carrying on all evaporation experiments; it was floated in a tank 4 feet in diameter, containing 30 inches depth of water. During the period of thirteen years, from January 1879 to December 1891, this evaporator has never once been out of order, or been interfered with in the slightest degree by frost. Experiments were made with some 5-inch evaporators as to the effect of colour on the amount of evaporation, one being painted white, another black, and the results given by these gauges were compared with a copper gauge exposed under similar conditions. This comparison was the means of showing that the greatest errors in evaporating gauges arise from the capillarity of the water rising on the sides of the gauge, and thus inordinately increasing the amount of evaporation. Consequently a small gauge having a larger amount, in proportion, of side area than a larger gauge, gives a very much greater amount of evaporation. The results from the floating evaporator, 1 foot in diameter, show that the average amount of water evaporated annually during 1879-91 was 19.948 inches. It was found, however, that, as a rule, during the period from October to March, there were certain occasions when condensation was measured. The amount of these condensations in thirteen years averaged .308 inch per annum. The 5-inch evaporating gauge, freely exposed to atmospheric influences, gave during the same period (1879-91), an average annual depth of evaporation equal to 38.185 inches. The average annual evaporation, during the three years 1879-81, from the 5-inch copper gauge standing in water was 27.90 inches, from one painted black 22.97 inches, and from another painted white 21.74 inches, whilst a gauge of the same dimensions, freely exposed in the atmosphere, gave, in the same period, 36.96 inches, and the 1 foot floating evaporator, 19.40 inches. The 5-inch copper gauge gave a larger amount of evaporation than the gauge painted black.—Mr. Latham next described some percolation experiments which were carried out by Mr. C. Graves at Old Ford, by Messrs. Dickinson and Evans at Hemel Hempstead, and by Sir J. B. Lawes and Dr. Gilbert at Rothamsted. He then detailed the results of his own experiments, and also the gaugings of the underground waters in the drainage areas of the rivers Wandle and Graveney. He further stated that in the course of his observations on the flow of underground water, he had observed that at certain particular seasons of the year it was possible to indicate the direction and volume of the flow of underground streams, even when they were at a considerable depth, owing to the formation of peculiar lines of fog.—Dr. C. Theodore Williams was elected President for the ensuing year.

PARIS.

Academy of Sciences, January 26.—M. Duchatre in the chair.—On the properties of the loxodromics of a cone of revolution, and their application to the conical spring, by M. H. Resal.—*Résumé* of solar observations made at the Royal Observatory of the Roman College during the last quarter of 1891, by Prof. Tacchini. Spots and facule show a slight diminution when their frequency is compared with that of the preceding quarter. On no day, however, has the sun been observed free from spots.—Experimental study of the decimal equation in transit observations, made at Lyon Observatory, by MM. André and Gonessiat.—On a real algebraical curve with constant torsion, by M. E. Fabry.—On the characteristic equation of water-vapour, by M. Ch. Antoine. The author shows that the weight,  $\varpi$ , of a cubic metre of water-vapour at a temperature  $t$ , and under a pressure  $H$ , is given by the relation

$$\varpi = \frac{19.9H}{278 - 0.365\theta + t^2}$$

in which  $\theta$  represents the temperature of the vapour at saturation under the pressure  $H$ .—Remarks on the subject of the experiments made by M. Gouy on the difference of potential produced by contact, by M. H. Pellat.—On Hertz oscillations, by M. A. Perot. In a recent work (*Wiedemann's Ann.*, xlv, pp. 74 and 92) Bjerkes shows that the oscillations of electro-motive force produced in a conducting wire by Hertz's method ought to be represented by the equation—

$$Y = Ae^{-a(t-\theta)} \sin \pi \left( \frac{t}{\tau} - \phi \right).$$

M. Perot finds that the formula proposed is supported by experiments.—On aplatinit, by M. A. Broca.—The estimation of molybdenum, by M. E. Péchard. The compound containing the molybdenum is heated in a current of HCl, when  $MoO_3 \cdot 2HCl$  volatilizes, is collected, dissolved in water, with the aid of nitric acid if any of the blue reduction compound is formed, and the solution evaporated to dryness; the molybdic acid is then weighed.—On the stereochemical constitution of diacetyl tartaric acid, by M. Albert Colson.—On some soluble colouring-matters produced by bacteria in medicinal distilled waters, by M. L. Viron.—On the existence of nitrification phenomena in media rich in acid organic substances, by M. E. Chuard.—Ammonia in rain-water and in the atmosphere, by M. A. Muntz.—In a former paper the author stated that the rain-water of tropical regions was richer in ammonia than that of temperate climates. This conclusion was combated by M. Lévy, who showed that the proportion of ammonia in rain caught at Montsouris was greater than that recorded by M. Muntz. The latter gentleman now points out that the observations made at Montsouris, or near any populous district, do not furnish proper criteria for the judgment of his first statement.—Earthworms and the bacilli of tuberculosis, by MM. Lortet and Despeignes.—On the inoculation of *dourine*, by M. Ed. Nocard.—Researches on the nervous system of Crustacea, by MM. F. Jolyet and H. Viallanes.—On the pelagic fauna of Dyrefjord (Iceland), by M. G. Pouchet.—On an elliptical halo observed around the moon on January 14, 1892; extract from a letter addressed to M. Cornu by M. Hamy.

BOOKS, PAMPHLETS, and SERIALS RECEIVED.

BOOKS.—*L'Évolution Sexuelle dans l'Espèce Humaine*; Dr. H. Sicard (Paris, J. B. Baillière).—*Les Problèmes de la Géologie et de la Paléontologie*; T. H. Huxley (Paris, J. B. Baillière).—*Report on the Scientific Results of the Voyage of H.M.S. Challenger*; Deep-Sea Deposits (Eyre and Spottiswoode).—*Treatise on Chemistry*, vol. iii. Part 6; Sir H. E. Roscoe and C. Schorlemmer (Macmillan).  
PAMPHLETS.—*Guide to the Examinations in Chemistry and Answers to Questions*; W. J. Harrison (Blackie).—*Guide to the Examinations in Geology and Answers to Questions*; W. J. Harrison (Blackie).  
SERIALS.—*The London and Middlesex Note-book*, vol. 1, No. 4 (Stock).—*Bulletin de l'Académie Royale des Sciences de Belgique*, No. 22, tome 22 (Bruxelles).—*Quarterly Journal of the Geological Society*, vol. 47, Part 1, No. 189 (Longmans).—*Rendiconto dell'Accademia dell' Scienze Fisiche e Matematiche (Sezione della Società Reale di Napoli)*, January-December 1891 (Napoli).

CONTENTS.

PAGE

Carpenter by Dallinger. By Prof. E. Ray Lankester, F.R.S.	313
Elementary Thermodynamics. By C. G. K.	314
The Century Dictionary	316
Our Book Shelf:—	
Sclater: "List of the Snakes in the Indian Museum."	
W. T. B.	317
Conn: "The Living World: Whence it Came and Whither it is Drifting"	317
Stuart: "Adventures amidst the Equatorial Forests and Rivers of South America"	317
Letters to the Editor:—	
Cirques.—Prof. G. Frederick Wright; Prof. Israel C. Russell	317
Large Meteors of January 24, 1892.—W. F. Denning	319
On the Relation of Natural Science to Art.—W. Ainslie Hollis	319
Ice Crystals.—Gilbert Rigg	319
A Tortoise included in Ice.—Frank Finn	320
Alpine Rubi.—T. D. A. Cockerell	320
Utilization of Homing Pigeons. (Illustrated.) By W. B. Tegetmeier	320
Notes	322
Our Astronomical Column:—	
New Star in the Milky Way	325
Observations of Mars	326
Solar Prominence Photography	326
Re-discovery of Brooks's Comet (1890 II.)	326
Electrotechnics. By Prof. W. E. Ayrton, F.R.S.	326
Photography as a Branch of Technology. By Prof. R. Meldola, F.R.S.	331
University and Educational Intelligence	334
Societies and Academies	335
Books, Pamphlets, and Serials Received	336

THURSDAY, FEBRUARY 11, 1892.

*THE VACANT CHAIR OF ASTRONOMY AT CAMBRIDGE.*

OUR Note of last week has brought us several communications with regard to the Chair of Astronomy rendered vacant by the lamented death of Prof. Adams. Before the note was written only certain names had reached us; but since then we have heard from the Rev. A. Freeman that he is a candidate for the Chair, and he has also been good enough to forward to us copies of papers on astronomical subjects which he has communicated to the Royal Astronomical and the Cambridge Philosophical Societies. We are very glad, therefore, to comply with what we presume is his desire that we should state that he is a candidate.

The other communications to which we refer are of more general interest, as they raise questions almost of national importance. We are informed, for instance, that it has been suggested that the Observatory should be disconnected from the vacant Chair. That is the first point. Another is that there is an idea prevailing at Cambridge that in such a subject as Astronomy the Professorships may be well regarded as honourable rewards or pensions to men who have rendered the University service as College tutors, or who have spared the professors and tutors labour by acting as coaches, the contributions these gentlemen may have made to astronomical science being considered as a matter of secondary importance.

With regard to the first point, we believe it will be generally conceded—it certainly will be conceded by those who know anything about the organization of that land of Universities, Germany—that an astronomical Observatory must take exactly the same place with regard to astronomy as physical, chemical, and biological laboratories do with regard to the sciences for which their aid is now regarded as essential, even at Cambridge. It should be clear, therefore, that in an University which professes to teach astronomy—to say nothing of that University rendered illustrious by the name of Newton—it would be as impolitic and as stupid a thing to dissociate the physical laboratory from the Professorship of Physics, the chemical laboratory from the Professorship of Chemistry, and the biological laboratories from the Professorships of Biological Science, as it would be to sever the astronomical Observatory—which in a University should always be a laboratory as well—from the subject of astronomy. And we confess it does not seem possible to us that such a step can be seriously contemplated; but certainly, were it done, the University would become a laughing-stock; and more than this, Cambridge would be reversing its scientific history. As far back as 1704, the Plumian Professorship of Astronomy was founded for the promotion of practical astronomy, especially to describe the parts and uses of astronomical instruments, and to prove and exemplify the mathematical formulæ required in the reduction of observations. It is worth while to point out that the wisdom of this foundation is proved by the fact that this is exactly the basis on which the astronomical subjects are generally treated in the German Universities. Take, for instance, the Observa-

tory at Leipzig. Prof. Bruns lectures to his students for four hours a week on the parts and uses of astronomical instruments and the cognate subjects; and, in addition to these, the mathematical treatment required in the reduction of observations and in ordinary computations are included in a separate course of instruction of two hours a week, and the students of both these courses join in the work of the Observatory, and are glad to do it.

We do not know whether the terms of Dr. Plume's bequest are still adhered to by the present Plumian Professor of Astronomy, but there is no doubt that it was in relation to the work so definitely laid down for this Chair that the Cambridge Observatory was established; and it is a matter of history that, when Prof. Woodhouse was succeeded in 1828 by Airy as Plumian Professor and Director of the then newly-erected Observatory, his work in the direction laid down by the foundation marked an epoch in modern astronomy. There are few first-class Observatories in the world at the present time in which the method of publishing adopted by Prof. Airy for the Cambridge Observatory is not followed with faithful accuracy, and let it be mentioned that all of the work, down to the minute computations and even the copying, was done by Airy himself.

During the tenure of the Lowndesian Professorship by Adams, the Observatory was separated from the Plumian Professorship and transferred to the Lowndesian, and this represents the present condition of things.

It is perfectly obvious, from what has been said, that to transfer now the Observatory from both the Professorships would be to run counter to the past history of Cambridge. It should be equally clear that this among many bad results might, in all probability, follow. The modicum of astronomy in the general sense now taught at Cambridge would be taught by men who, by the absence of material means, would not only be incapacitated from teaching the subject properly, but even from learning the new developments of it. The Professorship might soon become an intensified sinecure; while the Director of the Observatory, who would be the only one in the position of being able to learn, would yet, by the conditions of the problem, not be in a position to teach.

We now come to the second point—that relating to the astronomical qualifications of those who are candidates for the Chair. We cannot believe that this present year of grace—with a new astronomy breaking in upon us on all sides by the introduction of physical inquiries, experimental work, application of new instruments, and the like—can be a good time for dispensing with a practical acquaintance with the subject among the candidates for a Chair of Astronomy at Cambridge or anywhere else.

The subject, indeed, is one in which we are at present scarcely holding our own, while America and Germany are spending hundreds of thousands of pounds for the new equipments necessitated by the new methods. Surely Cambridge cannot be content that the Professor appointed is to be absolutely ignorant of the material equipment of the science; that he shall have no instruments to demonstrate to his students; nay, that he may not know one end of one from the other, and at the same time be rather proud that it is so, on the ground that contact with masses of metal might probably interfere with the purity of the conceptions of his mathematical mind.

It is, of course, agreed by everybody that there are mathematical investigations required in astronomy which can be, and have been, brilliantly carried out without the use of astronomical instruments. Looming large among these are tables such as those produced by Leverrier, Newcomb, Hansen, and many others that might be named; and were there at present among us a man who was distinguishing himself in such investigations, it might, under certain circumstances, be permissible to *waste* an Observatory by placing him at the head of it. But these are not the present circumstances. As it is, although England and Cambridge have made noble contributors to astronomy in the past, at the present moment there is no such man. The raw material produced by Greenwich is worked up abroad, and reimported for home consumption; while, on the other hand, the number of Observatories and Astronomical Chairs in this country is so small, that there are no inducements to an astronomical career, so that astronomy bids fair to be soon an extinct profession.

This is why we believe that it is essential, to save the situation, that astronomical professorships should be conferred upon astronomers, and that the existing Observatories should be saved from becoming sleepy hollows for mathematicians, however distinguished, who have given no hostages to fortune in the shape of noble astronomical work achieved.

The recent gift to the University by the late Mr. R. S. Newall even suggests that the present time might be taken advantage of to extend the present Observatory—if by no other means, then by a national subscription—so that it may become an institution as important for the promotion of astronomy as the Cavendish Laboratory, and others which might be named, are for the sister sciences.

We believe that there would be a general enthusiasm to contribute towards a building which should be a national memorial to Newton and Adams in the University which they have rendered illustrious by their labours; and if such a consummation could be aided by the suppression or suspension for a time, of one of the existing Chairs, we believe that the Cambridge authorities would have public opinion with them. We do not think that the number of astronomical students is now very great, or that the classes of the Plumian Professor are inordinately large; probably, therefore, no inconvenience would be caused by such a temporary suspension, while the gain to science and to the University would be permanent.

EDITOR.

#### THE CATALOGUE OF SCIENTIFIC PAPERS.

*Catalogue of Scientific Papers* (1874-83). Compiled by the Royal Society of London. Vol. IX. (Cambridge: University Press, 1891.)

THE Royal Society's "Catalogue of Scientific Papers," of which the ninth volume has just appeared, is the outcome of a movement which dates back nearly forty years. At the Glasgow meeting of the British Association which was held in 1855, a communication from Prof. Henry, of Washington, was read, "containing a proposal for the publication of [a catalogue of] philosophical memoirs scattered throughout the Transactions of Societies in

Europe and America, with the offer of co-operation on the part of the Smithsonian Institute." This proposal was referred to a Committee consisting of Mr. Cayley, Mr. Grant, and Prof. (now Sir Gabriel) Stokes; and their report was presented next year at the Cheltenham meeting of the Association. The scheme set forth in this report was that of a catalogue embracing only the mathematical and physical sciences, but comprising a subject catalogue as well as a catalogue according to the names of authors. There were to be paid editors, "familiar with the several great branches respectively of the sciences to which the catalogue relates," and the work was to include, besides Transactions and Proceedings of Societies, journals, ephemerides, volumes of observations, and "other collections not coming under any of the preceding heads."

In this form the scheme came before the Royal Society in March 1857, General Sabine having requested, on the part of the British Association, the co-operation of the Society in the undertaking. The scheme, after the usual amount of discussion in Committees and Councils, at length got upon its feet, walking, however, at first, in a wary and tentative manner. It was narrowed to a *manuscript* catalogue, the question of printing being deferred; it was to be a catalogue of periodical works in the Royal Society's library only (though it may be remarked, by the way, that that library is particularly rich in scientific serial literature); the suggested American co-operation, moreover, was dispensed with, and the work undertaken at the Society's own charge. In one important respect, however, the scheme was greatly widened, for the idea of confining the Catalogue to the mathematical and physical sciences, which had been put forward in the report to the British Association, was thrown overboard, and it was wisely decided "that all the sciences should be comprehended." The tentative restrictions were, of course, finally relaxed. It was resolved to extend the indexing to works in other libraries not contained in the library of the Royal Society; and in 1864, when the question of printing had to be faced, it was decided to offer the Catalogue to Government for publication.

The cost to the Society of compiling the material for the first series of the Catalogue was considerable, and many of the most eminent of the Fellows had spent no small amount of time, not only in superintending the progress of the work at home, but in corresponding with Academies abroad, with the view of making the list of serials to be catalogued as complete as might be. It was therefore with some reason that the Lords of the Treasury, in resolving to print the Catalogue at the public expense, stated that they had regard "to the importance of the work, with reference to the promotion of scientific knowledge generally, to the high authority of the source from which it comes, and to the labour gratuitously given by members of the Royal Society for its production." The printing of this first series of the Catalogue covering the scientific serials from the year 1800 to 1863, was commenced by the Stationery Office in 1866, seven Fellows of the Royal Society undertaking to read the proof-sheets gratuitously. The sixth and last volume of the series, completing the alphabet, was issued in 1872.

It is in the nature of such an undertaking that it never

comes to an end, and no sooner is Z reached than the compiler has to begin again at A. An additional decade of serials, embracing the years 1864-73, containing about 99,000 titles, and filling two additional quarto volumes (vols. vii. and viii.), was completed in January 1876, and published by Her Majesty's Stationery Office in 1879. But now the troubles of the Royal Society began. The work of the next decade went steadily forward; but as it neared completion it was found, so rapidly does the bulk of scientific serials increase, that, even keeping the Catalogue on the old lines, and making no considerable addition to the number of serials catalogued, ten years of memoirs, which formerly filled two volumes, would now fill three; and, to add to the difficulty, the Treasury now informed the Society that the "Catalogue of Scientific Papers" would not be continued as a publication of the Stationery Office." Parliament voted, however, a gift towards the charges of publication, and this, supplemented by the Royal Society's own funds, and the enterprise of the Cambridge University Press, has enabled the decade to be printed.

So much for the past of the Catalogue; and now a word as to its future. The preface to the volume under review states—what we have hinted at above—that the list of works catalogued "by no means comprises the whole of the scientific periodicals which at the present day are being constantly published in various languages." We believe it is no secret that the Committee of the Royal Society who have the superintendence of this great work have themselves printed and distributed among the Councils of various scientific Societies, for revision or additions, a list of no less than 540 additional serials, which may, might, should, or could be catalogued, so far at least as regards the principal memoirs which they contain; and it is well known to every scientific man how rapid is the multiplication of scientific serials, and how increasingly difficult becomes the task of keeping oneself acquainted with their contents. We are glad to learn, from the preface already quoted, that "the President and Council have it in contemplation to issue a supplementary volume, in which will be catalogued all the most important papers that have appeared from 1800 to 1883 in periodicals not hitherto indexed." We wish them well through their task, only venturing the gentle hint, "Bis dat qui cito dat." Nothing is said in the preface about future decades, but we sincerely trust that, notwithstanding the alarming increase of periodicals and the unfortunate withdrawal of Government aid, some means will be found for continuing the work: perhaps a hint might be taken from the British Association Report which initiated the whole undertaking, and by which it appears that America was willing to help.

One other matter needs to be mentioned—the important matter of a subject-index. Such an index, as we have already stated, formed a part of the original scheme, and as certain correspondence in our own columns (vol. xli. p. 341; xlii. p. 126) would seem to show, the Royal Society, though they have not yet seen their way to undertake it, still bear this great desideratum in mind. The undertaking was perhaps nearer than at any other time to being actually set on foot, when, in 1870, Dr. Carus visited London, and actually spent some weeks at the Royal

Society's apartments in planning and making specimens of such an Index Rerum. Unfortunately, the Franco-Prussian War prevented the return of Dr. Carus to London as had been arranged, and the work was never continued. How difficult such an undertaking is, perhaps few fully understand, requiring as it does, at the very threshold of the work, a complete and perfect classification of all the sciences, and involving, moreover, all kinds of difficult questions and perilous cross-divisions. But, difficult as it is, we trust that, to the great advantage of science, and the true "promotion of natural knowledge," the Royal Society may yet accomplish a work so greatly needed.

X.

#### THE ANEROID IN HYPSONOMETRY.

*How to Use the Aneroid Barometer.* By Edward Whympcr. (London: John Murray, 1891.)

IN undertaking a somewhat laborious investigation of the behaviour of the aneroid under great variations of pressure, and in publishing the results in the little pamphlet that bears the above title, Mr. Whympcr has rendered a service to travellers and geographers, which they will acknowledge not the less cordially that it brings with it the bitter reflection that very much of their past work in determining mountain heights by means of that convenient instrument, is probably seriously in error.

All who have had any experience in testing aneroids in the usual way, viz. by subjecting them to gradually reduced pressures under the air-pump, and comparing their readings with the concomitant indications of the manometer, are aware that the variations of the two instruments with falling and then with increasing pressure are by no means concordant; but it will probably be new to most that, when the aneroid is allowed to remain for some weeks under the reduced pressure, its indications continue falling, and to such an extent that its final error in certain cases is five or six times as great as when the exhaustion was first completed. Now this is precisely the condition experienced by travellers on high plateaux or great mountain tracts, where days or perhaps weeks are passed at altitudes of many thousands of feet above the sea-level. The instrument on which they rely for their elevations has been undergoing a rapid and not inconsiderable fall, which is merely an after-effect of the ascent already accomplished and recorded; and if, after returning to low levels, some weeks elapse before they again compare it with a mercurial standard, the whole of this accumulated error will have disappeared, and it may even have been replaced by an error in excess of the original reading. The Kew certificate of the aneroid's performance will afford no clue to its detection, and the elevations they have determined during their sojourn at high levels will be uniformly in excess of the truth.

It was an experience of this kind on the high plateau of Ecuador that first drew Mr. Whympcr's attention to this peculiarity in the behaviour of the aneroid. But he was not working in the dark. Together with a battery of aneroids he carried with him a mercurial barometer, and by dint of frequent comparison with this standard, he was

enabled to follow the erratic variations of the former instruments through all the changes of pressure to which they were subjected in the course of his travels. Armed with this experience, on his return to London, he undertook a series of systematic experiments, not only with the instruments that he had used on the Andes, but also with a large number furnished for the purpose chiefly by Messrs. Hicks and Casella. These were subjected to conditions which reproduced as nearly as possible those experienced on the journey, and their behaviour was noted under all the varying circumstances. The results of these experiments were that all aneroids, when brought under a low pressure, continue falling for four or five weeks, and in some cases longer; that the amount of the total fall varies greatly with different instruments; and that, in general, two-thirds of the fall takes place in the first week. Mr. Whympster says: "I have seen the index error of an aneroid grow to as much as four inches; in several instances there have been alterations of more than an inch, and in numerous instances there have been alterations from scarcely appreciable errors to + or - errors of two or four tenths of an inch." On the other hand, aneroids that have been kept for some weeks at a low pressure, when restored to the full pressure of the atmosphere, take many weeks to regain their condition of equilibrium; and when they have attained this final condition, their readings are sometimes higher, sometimes lower, than their original values at the same pressure. The greater part of the recovery takes place in the first week, and a considerable part in the course of the first day.

Notwithstanding this sluggishness of action, Mr. Whympster finds that the aneroid may be usefully employed for measuring differences of altitude when all the readings are taken within a short interval of time; the shorter the better, so that the data compared are only the first effects of the changes of pressure; and this equally whether the base station is at a high or low level. He gives an instance of this in his determination of the depth of the great ravine of Guallabamba, north of Quito, at the top of which his mercurial barometer read 21.692 inches, and the two aneroids that he carried with him gave readings respectively 0.552 and 0.752 inch too low. But when the three instruments were next read, two and a half hours later, at the bottom of the ravine, the mercurial barometer indicated a rise of 2.237 inches, and both the aneroids a rise of 2.260 inch, involving an error of only 1 per cent. In this instance, the difference of elevation as shown by the aneroids was vitiated by a very small error, but the absolute heights above sea-level as obtained from their readings would involve errors of more than 600 and 800 feet respectively.

That this was no accidental result was subsequently confirmed by an experiment on twenty-two aneroids (all having large but very varied errors). After these had been kept a week at a pressure of 21.692 inches (of the manometer), they were gradually restored in the course of two and a half hours to a pressure of 23.929 inches; and, with a single exception, the rise of the aneroid readings ranged between 2.130 and 2.360 inches, the mean of the whole being 2.218 inches.

As the general result of his experience, Mr. Whympster concludes that all aneroids lose on the mercurial barometer when subjected to diminished pressure, and that

the loss is the greater the greater the reduction of pressure; that when diminished pressure is maintained continuously, the loss commonly continues to augment during several weeks, but in a constantly diminishing ratio; that when pressure commences to be restored, the aneroid endeavours to recover the previous loss, and some gain more than they have lost; but the recovery is gradual, and usually extends over a greater length of time than the period during which the diminished pressure has been experienced; finally, that the index errors of aneroids are never constant, so that apparently no process of verification can be trusted to yield corrections for permanent application, even though time be made a factor of the correction formula.

It was no part of Mr. Whympster's purpose to go deeper into the matter, and to ascertain wherein lay the source of the irregular action of his instruments. But it is evident that this must be known before we can look for any important improvement in the construction of the aneroid. In all probability it lies in the varying elasticity of the thin corrugated disk that forms the cover of the exhausted chamber, the alternate rings of which are thrown into a state of strain and stress in the process of exhaustion, and which strain and stress are varied with every change of the external pressure. Perhaps some clue to the cause may be found in the results of Mr. Herbert Tomlinson's experiments on the elasticity of metallic wires after deformation by tension or torsion,<sup>1</sup> since he found that, after such treatment, the metal takes a considerable time to recover its normal elasticity. It is, indeed, by no means certain that such changes of pressure as were dealt with by Mr. Whympster are sufficient to produce deformation, but the aneroid affords a very delicate measure of any change of elasticity in the corrugated disk, and there is so much resemblance in the results of Mr. Whympster and Mr. Tomlinson's experiments as to make it at least not unlikely that there is a community of cause.

Meanwhile, travellers must bear in mind that unless the aneroid can be frequently verified by comparison with a mercurial barometer, its indications can be trusted only for such small differences of elevation as can be measured within an interval of a very few hours. A rough verification can, indeed, be obtained with the boiling-point thermometer, as is recommended by the authors of "Hints to Travellers," and this will at least enable them to avoid large and accumulated errors. A fair idea of the degree of accuracy that may be expected of this latter instrument in practice, is afforded by Dr. Scully's simultaneous observations of the mercurial barometer and the boiling-point thermometer in his journey over the Karakoram from Leh to Yarkand, which will be found in vol. i. of the "Indian Meteorological Memoirs." H. F. B.

#### WALLER'S HUMAN PHYSIOLOGY.

*An Introduction to Human Physiology.* By Augustus D. Waller, M.D. (London: Longmans, Green, and Co., 1891.)

IN these days, when the cult of the examination fetish is in the ascendant, and we are rapidly approaching the condition of the unchanging students of Confucius,

<sup>1</sup> Phil. Trans., 1883.

it is natural that the first question a student asks about a new book on physiology should be, "Is it the book for the College?" or the M.B., or whatever may be the examination most in vogue at his school. And this question is typical of the effect of examinations for evil, of their tendency to make men read exclusively up (or down) to the requirements of the examiners, disregarding the fact that the elementary physiology and anatomy they learn are to furnish their only weapons with which to attack the, for them, far weightier problems of pathology and treatment in their medical and surgical aspects.

On the other hand, it is a consolation to think that a good text-book must extend its beneficial influence to examinations as well as examinees, and thus improve the physiological teaching, not only by providing a trustworthy book of reference for the students, but also by putting a stop to cramming for examinations, which now forms so large a part of the teaching at London schools; for so surely as examinations improve will cramming assimilate itself to the proper teaching, and so become a work of supererogation.

I may say at the outset that Dr. Waller's book falls into the latter category, and is really the best recent work in the English language on human physiology. It presents a complete elementary account of the present state of the science, and is especially distinguished from the text-book most in vogue at the present time by its objectivity. Without loading his text with references and names, Waller retains personal interest in his work, and quotes original experiments sufficiently to attract the attention of the reader, and to give him (so far as is possible in a text-book), a real knowledge of the subject, and opportunity to discriminate between the diverse views with which the science is burdened.

I mean, no reader is compelled to accept the facts he learns here on the *ipse dixit* of the author. The facts are presented plainly enough, and their significance discussed, but the student can, if he has the habit of thought, weigh the evidence for himself, and perhaps come to a different conclusion from the author.

If we may be allowed to alter the context of a sentence of the preface, giving references and original experiments is useful "because it helps to correct that credulous bias or primitive 'suggestibility' which is a physiological property of the human brain, and only too apt to be fostered by unmitigated bookwork."

Dr. Waller follows the time-honoured division of the subject into vegetative and animal physiology; the latter, which includes the nervous system and its instruments, occupying half the entire work (270 pages).

Some might consider this too much space to be devoted to this part of the subject in a book intended primarily for, and certain to be used chiefly by, medical students. But one must consider that no other department of physiology can be so immediately applied to clinical work as that treating of the nervous system. In fact, a third year's man, who has learnt this well, requires merely a little book knowledge to recognize the most recalcitrant forms of nervous disease, which would hopelessly elude the diagnostic powers of many an older practitioner, less versed in the latest advancements of neurological science.

In the eye wards, too, an exact knowledge of the

working of the normal eye is absolutely essential, and one often hears oculists complain that they have to teach students the physiology of the normal eye before they can start on their own proper subject; and this is partly owing to the fact that these subjects are perhaps the hardest part of physiology, and partly because the student comes to them at the end of the session, and is tempted to treat them as coming last also in importance. This, however, he will be unable to do if he takes the work before us for his text-book.

The second part is treated evidently *con amore*, and is an excellent account of this branch of physiology. The introductory chapter on "The General Plan of the Nervous System" (which occupies only ten pages) is especially to be commended for its lucid brevity, the outcome of a masterly grasp of the subject.

This chapter is followed in order by the physiology (1) of the peripheral organs, muscle and nerve; (2) of the sense-organs, eye, ear, &c.; (3) of the central organs, spinal cord, spinal bulb, and brain.

The section on muscle is prefaced with a short account of the chief instruments used in electrical experiments on muscle and nerve, and of Ohm's law.

The fulness with which nervous physiology is treated will make the work very acceptable to general readers, and especially to those who wish to acquire a physiological standpoint from which to attack the problems of psychology.

The first part of the work—"The Phenomena of Nutrition"—treats adequately of the subjects of the blood and circulation, respiration, nutrition, excretion, and animal heat, but does not quite reach the high standard of excellence of the second part.

In a second edition one would like to see the questions of coagulation and of the origin of urea treated a little more fully and precisely. Its value, too, as a text-book would be much improved if the headings at the beginning of each chapter were also incorporated in the text, or put at the side of the page so as to arrest the reader's attention.

The whole work shows evidence of careful revision, and is marvellously free from mistakes or printers' errors. On p. 103, in describing the effect of the interrupted current on the ventricle, it should be mentioned that the frog's ventricle is meant, and not the mammalian.

In conclusion, I may mention that the work is furnished with a useful bibliography (confessedly incomplete) and a good index.

E. H. STARLING.

#### OUR BOOK SHELF.

*Bulletin of the New York Mathematical Society.* Vol. I. Nos. 2, 3. (New York: 1891, November, December.) No. 2 opens with an article by Truman H. Safford founded upon three volumes of the "Catalog der Astronomischen Gesellschaft" (vols. iii., iv., xxiv., Leipzig, 1890), in which a sketch of the modes of observation since Bradley's time is given, and the excellence of the plan formulated by Argelander upheld. Prof. M. Merriman discusses the problem in least squares,—“to determine, by the method of least squares, the most probable values of  $a$  and  $b$  in the formula  $y = ax + b$  when the observed values of both  $y$  and  $x$  are liable to error.” An account is then given of a new Italian mathematical journal (*Rivista di Matematica*), edited by G. Peano, the cha-

acter of which is said to be somewhat similar to that of the *Bulletin*. Reviews follow of a work on the "Photographograph (Hagen and Fargis, of the Georgetown College Observatory), and of Dr. Craig's "Treatise on Linear Differential Equations, vol. i. (by J. C. Fields). Besides there is a note on "Nomenclature of Mechanics" (our readers are familiar with the discussion raised by Prof. Greenhill, anent the same matter, the equation  $W=Mg$ ). The "Notes" (in both numbers) give information respecting the Society and its doings. One property of numbers, out of many given, we give here—

$$4^5 + 5^3 + 6^5 + 7^5 + 9^5 + 11^5 = 12^5.$$

In No. 3 Dr. Fiske prints a *résumé* of a lecture, before the Society, "On the Doubly Infinite Products," which bristles with references to papers on the subject. Prof. Hathaway then, in a very interesting note on the "Early History of the Potential," sums up, in correction of an error that occurs in Todhunter's "History of the Theories of Attraction" (vol. ii. § 789, 1007, and 1138), "the evidence in favour of assigning to Lagrange" (as against Laplace) "the honour of the introduction of the potential into dynamics." Mr. J. E. Davies contributes a favourable review of Preston's "The Theory of Light."

To each number is appended a long list of new publications. This *Bulletin*, it will be seen, breaks new ground, and presents several points of interest to mathematicians.

*Guide to the Examinations in Chemistry.* By W. Jerome Harrison, F.G.S. Pp. 56. (London: Blackie and Son.)

THE greater portion of this little book consists of answers to the questions which have been set in elementary inorganic chemistry in the examinations held by the Science and Art Department during the period 1884 to 1891. The rest of the book contains general information regarding the Department and its examinations, and also supplies hints for the successful working of the papers.

The answers are but moderately satisfactory; it may be taken that the author has frequently underrated the difficulty of expressing concisely, and at the same time clearly, the meaning which he wishes to convey. The following extracts may be taken as instances:—

"Gunpowder . . . depends for its energy upon the suddenness with which the nitre parts with its oxygen."

"The terminations *-ide*, *-ite*, and *-ate* are given to the names of the acid-forming portions of salts."

"Nitrous water [oxide  $\frac{1}{2}$ ] dissolves in water equally, and as a whole. Air dissolves *unequally* in water, the oxygen being more soluble than the nitrogen."

The book is intended to be a companion to Sexton's "Chemistry, Theoretical and Practical."

*Manipulation of the Microscope.* By Edward Bausch. (New York: Bausch and Lomb Optical Company, 1891.)

THIS little treatise on the microscope, which is now in its second edition, is sure to find favour with workers with this instrument, as it forms a good introduction to books of a more advanced nature. The subject is not treated extensively, but just so far as to enable a beginner to know the whys and the wherefores of the various manipulations.

The first two chapters deal with the simple and compound microscopes, describing their adjustments, &c. Under "Objectives and Eye-pieces," which forms the heading of the next chapter, we find short but good descriptions relating to achromatism, resolving power, flatness of field, magnifying power, &c. In the chapters on "Requisites for Work," "How to Work," and "Advanced Manipulation," the beginner is shown how to set up his instrument, to illuminate the field properly, to use the high-power objectives, and, among other things, receives instruction in the dry and immersion adjustable objectives.

The selection of an instrument is always an important item to be thought of, and the author here gives some good sound advice both about it and the choice of its accessories, and about the care which should be bestowed on it to keep it in the best working condition. The appendix contains some considerations in the testing of objectives.

The work is one which all beginners with the microscope should read, while many a hint might be gathered by an advanced student.

*Harrow Birds.* By G. E. H. Barrett-Hamilton. (Harrow: Sold for the Harrow School Scientific Society by J. C. Willbee, 1892.)

THIS little volume ought to be of good service to the Harrow School Scientific Society, for whose benefit it has been prepared. The author was a member of Harrow School from 1885 to 1890, and evidently made excellent use of his opportunities for ornithological study. For facts which have not come within his own observation he has had recourse to the best authorities, and various gentlemen, whose names he gives, have contributed notes on the birds observed about Harrow during their school-life. The district covered in the list is contained within a radius of about five miles around Harrow. The list includes 197 species, of which 55 are partially or wholly resident, 27 are regular summer visitors, about 22 appear annually on migration or in winter, and the remaining 94 are visitors of rare or accidental occurrence. The species which breed regularly number 82.

#### LETTERS TO THE EDITOR.

[The Editor does not hold himself responsible for opinions expressed by his correspondents. Neither can he undertake to return, or to correspond with the writers of, rejected manuscripts intended for this or any other part of NATURE. No notice is taken of anonymous communications.]

##### The Theory of Solutions.

IN NATURE, vol. xlv. p. 293, appears a letter by Prof. Ostwald, in which he replies to a portion of my review of his book on solutions (NATURE, vol. xlv. p. 193).

Prof. Ostwald finds his main cause for objection in my conclusion that he is a supporter of the "physical" as distinguished from the "chemical" theory of solution. To such a statement he objects on the ground that he "cannot at all admit the existence" of a "contrast" between the two theories; and further that he intentionally neither set up nor attempted to answer the question—Is solution a physical or a chemical process?—because he holds it to be "unclear and therefore very harmful." In the rest of the letter he concerns himself mainly with expounding what he prefers to name the "new theory" of solution, and seeks to show that between it and the hydrate theory there is no antagonism or rivalry.

The first point to consider as bearing on the question at issue is the definition of the "new theory" which may be gathered from extracts such as the following:—

"The theory of solutions which I represent and defend consists" "of a certain number of laws, *i.e.* of exact relations between measurable quantities."

"The presentation of laws of solutions, as known up to the present, . . . forms the subject of my book."

But surely it cannot be admitted that a number of exact relationships constitute a theory; for theory is concerned with saying why such relationships should exist, with supplying ideas to connect them together. Now, contrary to the apparent meaning of the last quotation given above, Prof. Ostwald's book contained much of the nature of a true theory. Indeed, the ideas which seemed to determine the general treatment of the subject, and which formed the only justification for the free use made in the book of gaseous laws, were the hypothetical functions ascribed to the solvent and the dissolved substance. The hypothesis here involved, in conformity with what has been the usual custom in this country I termed the "physical theory," and I am at a loss to see how any reasoning based on the definition of the "new theory" affects the use of this term. For the theoretical matter given in the book evidently refers



to ideas differing from those involved in the "new theory," which, so far as extracts such as the above go, appears to include nothing whatever of a theoretical nature.

Even in Prof. Ostwald's letter there are, however, indications that in his book he went beyond the mere statement of the laws of solutions. For example, he says: "In my book the question is this one of facts, and although I have therein made more use of *molecular considerations* than I should at present hold to be proper, yet I have done so only to render more clear the actual relations, and never to prove quantitative laws."

Now it was solely the "development of the consequences of facts"—this use, which Prof. Ostwald admits to have been excessive, of "molecular considerations"—which has generally been, and was by me, styled the "physical theory." The facts themselves no one can question; indeed, I took pains to point out in my review that the facts, as given in the book, would alone serve to make it valuable. The theoretical matter, however, called for separate consideration. It alone was, and so far as I can see, it alone could be, designated the "physical theory."

In denying the contrast between the so-called chemical and physical theories, Prof. Ostwald declares that he never maintained "that no interaction takes place between the solvent and the dissolved substance." If such was his opinion when writing his book, it may be asked, Why in all fairness should he have defined solutions as homogeneous *mixtures*? Why did he not state clearly that interactions between solvent and dissolved substance were possible? It is quite true that, in my review, instances were given of chemical expressions used in the book, but no stress was put upon these by the author as indicating the general occurrence of chemical changes in solutions. They seemed to arise, not because of, but rather in spite of, the author's idea of the nature of solution, and could only be regarded as inconsistencies. The theme of the book was the explanation of the properties even of concentrated solutions by considering the interactions of molecules of the *same* kind, by treating the dissolved substance as if it were gasified. If such a method of treatment were described as "physical," I think the commonly accepted meaning of the word was in no way impaired.

Indeed, much of Prof. Ostwald's book can hardly be justified if interactions of a chemical nature are probable in solutions. For instance, several pages are devoted to the use of van der Waals's equation in dealing with solutions. To anyone familiar with the deduction of this equation, the validity of its application to a solution even when the solvent is regarded as indifferent is highly questionable. If, however, it is admitted that something of the nature of a chemical reaction may occur between solvent and dissolved substance, that the latter may not be in a pseudo-gaseous condition, then the application of the equation can hardly be termed otherwise than meaningless.

In conclusion, I can only express regret if my review has tended to create further misconception on this vexed question of solution. At the same time, I hope I have been able to indicate to Prof. Ostwald the points which led to my use of the terms to which he objects; and I venture to think that in the discrepancies which appear to exist between the ideas as given in his letter, and those which the reader has to gather from his book, is to be found sufficient reason for the use of the statements to which exception has been taken.

J. W. RODGER.

London, February 1.

### Arrow Poison.

In 1889 a French naval surgeon, M. Ledantec, published in the *Annales de l'Institut Pasteur* the result of some investigations he had made into the nature of the arrow poison of the natives of the New Hebrides. Wounds from these arrows give rise, as is well known, to tetanus, and M. Ledantec was able, by the subcutaneous injection of the scraped off poison, to kill guinea-pigs under typical tetanic symptoms. He learnt from a Kanaka that they are prepared by smearing the arrow-heads (which are made of human bone) first with tree gum and then with mud from a swamp, which mud he found to contain numbers of Nicolaïer's tetanus bacillus.

As far as I am aware, this has been recorded only of the natives of the New Hebrides and some of the neighbouring groups (the arrow poison of Stanley's dwarfs is certainly *not* the same), and I was therefore much interested some days ago by coming accidentally upon an old record which seems to show that the natives of the Cape Verd coast were accustomed, more than three hundred years ago, to get rid of their enemies in a

similar manner. In Hakluyt's "Voyager's Tales," published in 1589 (I refer to the little reprint edited in 1889 by Henry Morley), is the narrative of one Miles Phillips, in which occurs the following passage:—"Upon the 18th day of the same month (November 1567) we came to an anchor upon the coast of Africa at Cape Verde, in twelve fathoms of water, and here our General landed certain of our men, to the number of 160 or thereabouts, seeking to take some negroes. And they, going up into the country for the space of six miles, were encountered with a great number of negroes, who with their envenomed arrows did hurt a great number of our men, so that they were enforced to retire to the ships, in which contest they recovered but a few negroes; and of these our men which were hurt with their envenomed arrows, there died to the number of seven or eight in a very strange manner, with their mouths shut, so that we were forced to put sticks and other things into their mouths to keep them open." In the language of modern medicine, they succumbed to tetanus traumaticus. The voyagers left the coast soon after, and there is no further mention of the natives or of the wounded.

There is, of course, no proof that the arrows were poisoned with mud or earth, but the probability is considerable. The chief interest lies in the age of the record, which forms in some manner a pendant to the researches of M. Bissano (*Comptes rendus*, 1888), which showed the tetanus bacillus to have a very wide distribution in space.

It is a curious consideration that this and the other famous arrow poison, curare, both kill by their action on the voluntary muscles, the action of one being diametrically opposed to that of the other.

A. COPPEN JONES.

Davos Platz, Switzerland, January 30.

### The Implications of Science.

HITHERTO prevented from again writing, I cannot now remain passive and allow Mr. Dixon to escape from his irrational position under cover of a cloud of verbiage—like a cuttle-fish through water made turbid by its ink.

In my lecture I pointed out that certain truths are implied in all physical science. They *are* so implied. If Mr. Dixon thinks they are not, it is for him to show how experimental science could be carried on, with any real, serious doubt about them. This he has certainly not yet done.

Our knowledge of our own existence "in the present," is knowledge of a particular concrete fact, not of an abstract necessary truth. That "whatever feels, simultaneously exists," is such a "necessary truth," but it is an abuse of language to apply that term to anything which may cease to exist the moment after its existence is recognized.

That "nothing can simultaneously be existent and non-existent," does not at all depend upon "terms" or "definitions," but is a law of "things." It would not lose its validity and objective truth, not only if there were no such things as "terms" and "definitions"; it would not lose it if the whole human race came to an end.

I am glad to find my critic does "not doubt" that if he lost an eye his condition would thereby be modified, but if he does not also see that this applies and must apply everywhere and everywhere, I do not envy him his power of mental vision.

Oriental Club, February 2.

ST. GEORGE MIVART.

### The New Forest in Danger.

IN connection with my letter which appeared in NATURE of the 28th ult. (p. 295), it may interest some of your readers to know that the petitions, to which I referred, in support of the Bill for excepting the New Forest from the operation of the Ranges Act, 1891, have already been signed by Lord Walsingham, F.R.S. Prof. C. Stewart (President of the Linnean Society), Sir Joseph D. Hooker, F.R.S., Dr. P. L. Sclater, F.R.S., Mr. Osbert Salvin, F.R.S., Dr. A. Günther, F.R.S., Dr. H. Woodward, F.R.S., Mr. W. Carruthers, F.R.S., Dr. D. Sharp, F.R.S., Mr. Thistelton-Dyer, C.M.G., F.R.S., Mr. H. W. Bates, F.R.S., Mr. F. DuCane-Godman, F.R.S., Dr. G. Buchanan, F.R.S., Dr. B. Richardson, F.R.S., Prof. J. O. Westwood (Professor of Zoology, Oxford), Dr. Thorne-Thorne, F.R.S., Mr. J. G. Baker, F.R.S., Mr. W. H. Perce, F.R.S., Mr. Botting Hemsley, F.R.S., Mr. E. B. Poulton, F.R.S., Mr. R. McLachlan, F.R.S., Mr. C. B. Clarke, F.R.S., Major-General Carden, Prof. Jeffrey Bell (Secretary of the Microscopical

Society), Dr. Franklin Parsons, Mr. Daydon Jackson (Secretary of the Linnean Society), Mr. J. E. Harting, Dr. Bowdler Sharpe, Mr. J. Britten, Mr. E. Saunders, Colonel Swinhoe, Mr. A. W. Bennett (Vice-President of the Linnean Society), Mr. Percy Sladen (Secretary of the Linnean Society), Mr. D. Morris, Mr. Miller-Christy, and by a large number of other Fellows of the Linnean, Geological, Zoological, and Entomological Societies of London; and by the editors of the *Geological Magazine*, the *Journal of Botany*, the *Zoologist*, the *Entomologists' Monthly Magazine*, and the *Entomologist*.

HERBERT GOSS.  
Linnean Society, Burlington House, W., February 6.

#### ON THE NEW STAR IN AURIGA.

WE were enabled last week to make an announcement of the discovery of a new star in the constellation Auriga, as we received on Wednesday the Edinburgh Circular giving an account of the manner in which the first information had been received. A telegram was sent by Dr. Copeland to the Astronomer-Royal on the date of the reception of the post-card—Monday, February 1—and, as we have since learnt from the *Astronomische Nachrichten*, a telegram was also sent by Dr. Copeland and the Astronomer-Royal to Kiel. Unfortunately there is at present in England no local system for the distribution of astronomical intelligence of this character, so that it will probably be found that the fine night of Monday was only devoted to observations of the new star in a very restricted number of Observatories. The necessity for correcting this state of things has been pointed out by Mr. Lockyer in the *Times* of Friday, and it is to be hoped that some steps may be taken to rectify the defect. As it turns out, however, no very great harm has been done, for the new star, instead of degrading its light rapidly from the day of its discovery on February 1, seems if anything to have brightened, so that the changes in its light between Monday and Wednesday were probably not so great as those observed in Nova Cygni during the first two or three days of its visibility.

A telegram from Prof. Pickering communicated by the Astronomer-Royal to the *Times* of Monday seems to show that the star, instead of bursting forth suddenly about the date when the anonymous post-card was sent to Dr. Copeland, has really been visible since last December, perhaps even for a longer time; but in any case it has not been registered in any recognized Catalogue. Prof. Pickering states that he finds this star visible on three plates belonging to the series of the Draper photographs at different dates during the month of December. The telegram through the "Centralstelle für Astronomische Telegramme," Kiel, runs as follows:—"Copeland's Nova bright on photograph December 10, faint December 1; maximum December 20; spectrum unique.—PICKERING." It would thus appear that Prof. Pickering had photographed the new star on the three dates named in the course of the photographic mapping of stars and their spectra which he is carrying out at Harvard College Observatory. We do not yet know whether the plates were examined at the date on which they were taken, or whether the telegrams relating to the appearance of the Nova may have caused an examination to be made, but the spectrum was visible on all three plates.

As we stated last week, the observations in England commenced on Monday night at Edinburgh, on which date Dr. Copeland saw bright lines, and at the Royal Observatory on the same evening, when the new photographic 13-inch refractor was used for determining the exact position of the star. With this fine instrument the Astronomer-Royal was able to detect that the star differed from the other stars on the plate in appearance.

As to the work on Tuesday night, at present we know nothing. An announcement of the discovery appeared in the *Times* of Wednesday, on which date also, as we have already stated, Dr. Copeland's Edinburgh Circular

was received in London. On that night, therefore, which happened to be fine, observations were commenced at South Kensington, and two photographs were obtained, together with some eye-observations, which were communicated to the Royal Society by Mr. Norman Lockyer on the next day in a preliminary note, from which we make the following extracts:—

"Last night was fortunately fine, and two photographs were taken of the spectrum—the first exposed from 7.30 to 9, or for 1h. 30m.; the second exposed from 9.30 to 12.30, or for 3h. 0m. The first registered 13 lines; the second appears to contain some additional ones, but they are very faint, and have not yet been measured.

"A complete discussion of these photographs will form the substance of a subsequent communication, but already the following approximations to the wave-lengths have been obtained, the photographs being treated absolutely independently, means, however, being taken for the four least refrangible lines, as there has not yet been time to construct a proper curve for this region:—

Lines measured in the first photograph.			Lines measured in the second photograph.		
Wave-length.	Hydrogen lines.	Probable origin.	Wave-length.	Hydrogen lines.	Probable origin.
3933 K		Ca	3933 K		Ca
3968	H		3968	H	
4101	h		4101	h	
4128			4130		
4172		Ca	4172		Ca
4226			4227		
4268			4268		
4312		{ Hydro-carbon	4310		{ Hydro-carbon
4340	G		4340	G	
4516			4516		
4552			4552		
4587			4587		
4618			4618		

"I have recently taken up the question of stellar spectra, and find that a 6-inch object-glass with a prism in front of it is all that is required for the brighter stars. This instrument was employed upon the Nova, which is of about the fifth magnitude, so the exposures were necessarily long.

"For the eye-observations, the new 3-foot mirror which has recently been presented to the Astro-Physical Laboratory by Mr. Common was employed, but unfortunately the clock is not yet mounted, so that the observations were very difficult.

"C was the brightest line observed. In the green there were several lines, the brightest of which was in all probability F, the position being estimated by comparison with the flame of a wax taper. Another line was coincident—with the dispersion employed—with the radiation at wave-length 500 from burning magnesium wire. A fainter line between the two last-named was probably near  $\lambda$  495, thus completing the trio of lines which is characteristic of the spectra of nebulae. There was also a fairly bright line or band coincident with the edge of the carbon fluting at  $\lambda$  517 given by the flame of the taper. A feeble line in the yellow was coincident under the conditions employed with the sodium line at D.

"The hydrogen line at G was distinctly seen, as well as a band, or group of lines, between G and F.

"Nearly all the lines appear to be approximately, if not actually, coincident with lines seen in the various types of Cygnus stars, the chief difference being the apparent existence of carbon, hydrocarbon, and calcium in the Nova.

"The colour was estimated by Mr. Fowler as reddish-yellow, and by Mr. Baxandall as rather purplish. My own impression was that the star was reddish, with a purple tinge. This was in the 10-inch achromatic. In the 3-foot reflector it was certainly less red than many star of Group II. No nebulosity was observed either in the 3-foot or the 10-inch refractor, nor does any appear in a photograph of the region taken by a  $\frac{3}{4}$ -inch Dallmeyer lens with three hours' exposure. It should be stated that the camera was carried by the photographic telescope, the clock of which had had its normal rate purposely changed to give breadth to the spectrum.

"The photographs were taken and reduced by Messrs. Fowler and Baxandall. The eye-observations and comparisons were made by Mr. Fowler."

The nights of Thursday, Friday, and Saturday were hopelessly bad, but on Sunday night the weather cleared, and more photographs were taken at South Kensington, an account of which, we believe, has been communicated to the Royal Society. Observations of the Nova are therefore well in hand, and there is no doubt that a comparison of the photographic plates obtained in December and February will provide us with much minute information regarding the behaviour of our new visitor.

The remark in Mr. Lockyer's communication to the Royal Society, that the spectrum of the star contained nearly all the lines visible in the stars in Cygnus, is one of considerable interest and importance, because, if it be confirmed by subsequent observations, it will show that these stars in Cygnus cannot be stars in the true sense—that is, bodies like our sun. This seems pretty evident from the fact that their spectroscopic phenomena can be reproduced by another body which suddenly appears, and probably will rapidly become invisible. The idea that any of these bodies are "worlds on fire," as was once thought, need now no longer be discussed.

#### MR. TESLA'S LECTURES ON ALTERNATE CURRENTS OF HIGH POTENTIAL AND FREQUENCY.

IT is not often that the outward and visible signs of a great scientific success are so prominent as they were last week at the Royal Institution. The reports which have reached this country of the work of Mr. Nikola Tesla have made his name known to those who are watching or aiding the progress of electrical science. He was recently invited by the Institute of Electrical Engineers to lecture before it, and the interest which his coming excited spread in widening circles as the day on which he was to exhibit his experiments drew near.

It was evident that the ordinary meeting-room of the Institute would be too small, and the Managers of the Royal Institution placed their theatre at its disposal. Members of the Royal Institution, were, however, anxious to hear and see for themselves; and finally Mr. Tesla consented to lecture on two consecutive nights to the Institute and the Institution respectively.

On both occasions the room was full; on the first it was overflowing. Gathered round the lecture table was a crowd of those whose business it is, either as theorists or as practical men, to keep abreast of the wave of scientific advance; but as the youthful lecturer—who looks even younger than his years—with a modesty and charm of manner which were altogether irresistible, showed wonder after wonder, the interest of this critical audience deepened into enthusiasm. The speaker's broken English and imperfect explanations did not detract from his success. His marvellous skill as an experimentalist was evident and unmistakable, and his hearers left the room convinced, not only that another step forward had been taken, but also that in

Mr. Tesla we have a scientific explorer, who, if health and life be granted him, will travel fast and far.

Briefly, Mr. Tesla has done much to attain the continuous stream of electrical oscillations which Prof. Fitzgerald, at a recent meeting of the Physical Society, compared to a continuous whistle. The oscillations which Hertz studied die out almost instantaneously. Could they be maintained, a practically new weapon would be placed in our hands. Tesla does not, indeed, maintain them, but he renews them many times per second, and the results are marvellous.

Though the potential is enormous, the electrode of the apparatus can be safely handled. If a person in conducting communication with it touches a vacuum bulb or tube it glows, and if the tube is brought near to others it sets them a-glowing too. No return is needed, the current is completed through surrounding space. The phosphorescent materials in some of the beautiful tubes lent by Mr. Crookes shone brightly when one electrode only was connected with the coil. If the terminal is surrounded by an aluminium tube, the glow is notably increased. The experiment of making a vacuum-tube luminous by simply holding it in an oscillating field was successfully performed, and the lecturer himself received with impunity a crackling discharge, some six or eight inches in length, by holding his hand at that distance from the terminal of his coil.

All these things are not merely wonders. Mr. Tesla is working with an object. He is one of those who hold that a phosphorescent glow is the light of the future. He hints at artificial aurora spreading from the summits of towers of hitherto undreamt-of height, and he has at all events got as far as producing in air at atmospheric pressure a glowing plane bounded by two rings about a foot and thirty inches in diameter respectively. Whether his visions will all be realized may be doubtful. There is no doubt that they are guiding him aright. As Lord Rayleigh said in moving the vote of thanks, a door has been opened into a new region of inquiry, into which Mr. Crookes and Mr. Tesla have entered almost alone.

Those who some fifteen months ago heard Prof. Hertz acknowledge in terms of genuine emotion that he had built upon a foundation laid by Englishmen, that Englishmen had first recognized the importance of his work, and that from England its first reward had come, must have listened with pleasure when the part that this country has taken in the development of electrical science was referred to in a like appreciative tone by Mr. Tesla. It is not indeed that the achievements of our great electricians are bettered or rendered more important by acknowledgment, but it is pleasant to note how cosmopolitan science is becoming, and that among scientific workers the feeling of fellowship is overcoming that of rivalry. For the rest we can only congratulate Mr. Tesla alike upon his work and his reception, and the scientific world on the exhibition of a number of beautiful experiments which will afford food for useful reflection to theorist and experimenter alike.

A. W. R.

The announcement of Mr. Nikola Tesla's lecture to the Institution of Electrical Engineers excited widespread interest among all in the least degree interested in electrical science. The succession of almost marvellous experiments in which in great measure it consisted must have gone far beyond the anticipations of the most sanguine of those of the audience who had had no previous account of the nature and results of his work. It is not too much to say that the Royal Institution lectures mark a distinct epoch in the progress of theoretical and applied electricity. While, on the one hand, the experiments which the lecturer showed seemed to point to a possible revolution of our methods of electric lighting, on the other hand they must have suggested, if not for the first

time, in a new and forcible way, important questions of electrical theory, and the physiological effects of rapidly alternating currents. That he should have been able unharmed to place himself in the space between two tin-foil plates connected to the terminals of his rapidly alternating machine, was to the ordinary observer in itself sufficiently startling; but that he should have been able to present a piece of iron to one of the poles of the machine, drawing a spark of several inches in length with impunity, and thereby to interpose his body as a connecting link between the machine and a long vacuum tube which glowed like a flaming sword, must have appeared to many of those most conversant with electrical phenomena truly astonishing.

Hitherto, alternating machines of great frequency and high potential have been deemed peculiarly dangerous, and not without reason. But it did not follow, of course, that with a sufficient increase of the frequency of alternation, the danger might not completely disappear. It will be of great importance to inquire in what way the immunity of the experimenter from injury is brought about. Are impulses of 20,000 reversals per second and upwards without serious effect on the nervous system of the human body, so that conduction takes place through it without any disagreeable consequences? or is the conduction effected without the nervous system being concerned at all?

The delicate network of nerves in the eye is sensitive to a certain range of frequency of electrical vibrations, and perfectly insensitive to vibrations which lie outside that range in frequency. In the same way the insensitiveness of the general nerve-system of the human body interposed between a glowing vacuum tube and the terminal of a rapidly alternating machine or transformer may begin and end at much lower limits. There is also, of course, the interesting question of the distribution of these rapidly alternating currents in the somewhat complicated conductor formed by the human body, which may have a great deal to do with the result.

The admirable experiments of Mr. Tesla are only another instance of the way in which practical applications of science promote its progress, by enabling apparatus to be constructed on an engineering scale, and with all the security for effective action which the constructive art of the engineer furnishes so well. His simple alternating machine, running with very little clearance at a speed of about 2000 revolutions per minute, is itself a triumph of skill in design and construction, and well illustrates how desirable and even necessary it is to take advantage of all the aids to exactness, and they are many, which can be obtained from the refined machine tools and truth of design which characterize the engineering workshop of to-day. The ordinary optician of twenty years ago, with his imperfect lathes, and general utter want of power-driven appliances, his continual hand-fitting and shaping, and the absolute non-interchangeability of the parts of his instruments, has almost passed away; and even the physical laboratory has become in great measure an engineering workshop, in which are to be found Whitworth lathes and end-measuring machines adapted for the most exact work.

It ought to be recalled here that Prof. J. J. Thomson has been working in the same field, and has obtained somewhat similar results. These were made the subject of a very interesting demonstration to the members of the Physical Society on the occasion of their visit to Cambridge in May of last year. For a long time Prof. Thomson has investigated this subject both theoretically and experimentally, and his researches have thrown much light on the *rationale* of the very striking results obtained by Mr. Tesla and himself in their closely allied but independently carried out series of experiments.

One point in this connection is worthy of notice. Mr. Tesla insists strongly on the essentially electrostatic

nature of the phenomena illustrated by his lectures; while, on the other hand, *one* object aimed at in Prof. Thomson's experiments was to show that in a tube without electrodes luminosity could be produced by electrodynamic action alone—that is to say, in a field of electric force which is not electrostatic in the sense of admitting of the derivation of its intensity at each point from a potential function.

The changes produced in the distribution of electricity on neighbouring conductors will cause glow in a vacuum tube when a Holtz machine or Leyden jar is discharged; and this will in general be more or less operative. But it is not in general possible to separate the electromotive forces due to this cause from those due to electromagnetic action. Prof. Thomson has succeeded in some cases in screening off these electrostatic effects, and in producing a glow discharge in which electrostatic action could have little or no share.

The glow or flame discharges from the terminals of Mr. Tesla's induction coil, the glow discharge from the long wires stretched from the induction coil towards the roof of the hall, the glowing vacuum bulbs and phosphorescent tubes in the field between the parallel tin-foil plates attached to the transformer terminals are all phenomena of the highest importance; though, of course, they are only exceedingly striking and effective illustrations of experimental results already arrived at by the lecturer himself and others, and communicated in a more or less complete manner to the electrical world. The application of these, which Mr. Tesla suggests as a possible one in the future, would bring about an ideal form of electric lighting, which would transcend in luxury and convenience our present system of electric lighting by incandescent lamps as far as the latter transcends the oil lamps and tallow dips used by our near ancestors. Every drawing-room would become an electric field in a continual state of rapidly alternating stress, in which the occupants would live, experiencing no unpleasant effects whatever, while vacuum bulbs or phosphorescent globes and tubes, without care or attention, would shed a soft diffused light, of colour and intensity arranged to suit the most luxurious fancy. It would be interesting also to know whether, after all, habitual dwelling in a region of electric stress rapidly changed from one extreme of high intensity to the opposite, produced very slow physiological effects which could be traced in the improved health and longevity of the persons so dwelling, or the reverse. If such applications are made (and there does not seem to be any sufficient reason why they should not come to pass), the magnificent researches of Mr. Crookes, as well as those of other investigators to whom the lecturer justly and generously acknowledged his indebtedness, will bear some practical fruit in an almost totally unexpected manner, by becoming at once available in connection with a new and beautiful development of what is at present the most progressive of the physical sciences.

It does seem that we are on the point of farther great advance into the undiscovered domain of electrical science, and it is significant that it is likely to lie along one of the routes made clearer to us by the discovery and verification of the great theory of electrical radiation. Who knows what further discoveries may be obtained before the present century has come to an end? We are advancing so rapidly that no one can declare that the record of discovery of the nineteenth century has nearly closed. One important means of further investigating electrical radiation will be that which Prof. Fitzgerald made an attempt to find—a means of maintaining for any required length of time electrical vibrations of sufficiently high frequency. Mr. Tesla's results seem to promise that this problem may perhaps be solved before very long, and many outstanding questions of the electromagnetic theory of light thereby set at rest. In many other ways his researches are certain to promote scientific

discovery. To quote his own words: "The field is wide and completely unexplored, and at every step a new truth is gleaned, a novel fact observed." G.

WAVE-MOTION MODEL.

AS a teacher of Physics I have always experienced considerable difficulty in giving to elementary students of Sound a clear conception of the motion of the air in organ-pipes when sounding. In Weinhold's "Physics" a method is shown in which a series of sinuous lines, drawn on a sheet of paper, exhibit this motion when drawn across a narrow slit, but the difficulty attending the drawing of these lines has, I imagine, pre-

cluded its general adoption for class purposes. It struck me that it ought to be possible to draw a series of concentric circles upon a disk in such a way that, when rotated, the motion of the intercepted lines, as seen through a narrow radial slit, should correctly represent this motion. This, of course, is done for progressive waves by Crova's disk. After spending some thought upon the matter I succeeded in producing such a disk, a copy of which I inclose. It has given such satisfaction that I have been advised by several scientific friends to send a description of the method to you for publication, for the benefit of teachers and students generally.

In the following description I have given the dimensions which I myself employ in describing these disks, but they can of course be varied at will:—

A piece of stout cardboard should be taken about a

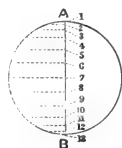

foot square. A line AB,  $\frac{1}{2}$  inch in length should then be drawn near the centre and a circle described about it, half of which should then be divided as shown into 12 equal parts. Perpendiculars should then be dropped upon the line AB, which is thus divided in harmonical progression in the points 1, 2, 3 . . . 13. With the

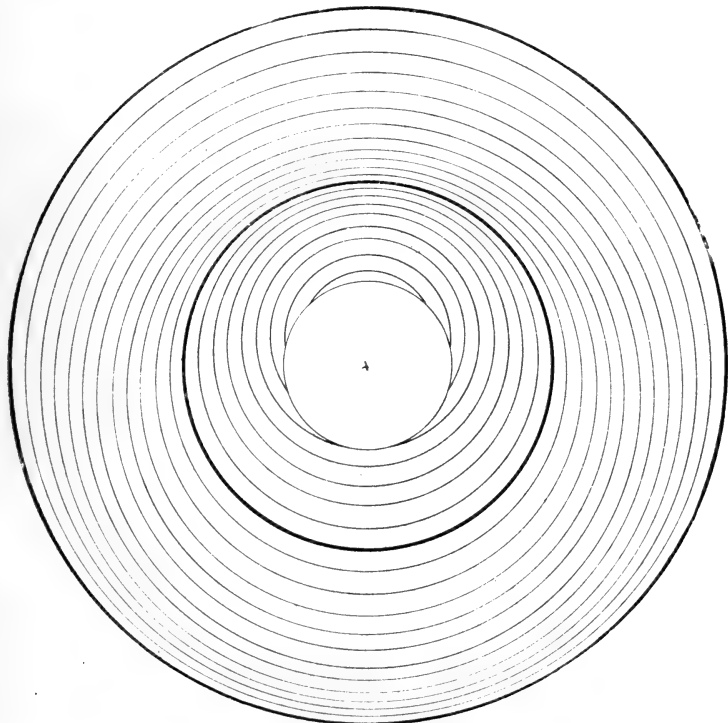

points 1, 2, 3 . . . 13, 12, 11, 10, 9, 8, 7 successively as centres, a series of circles should then be drawn beginning with a radius of  $1\frac{1}{4}$  inch, and increasing it each time by  $\frac{1}{15}$  inch. The last circle therefore, described with the point 7 as centre, has a radius of  $4\frac{8}{15}$  inch. The two circles described with the point 7 as centre, since they represent nodes, should be drawn rather thicker than the others to distinguish them.

The disk is now complete. It should be cut circular in shape and mounted to rotate upon a pin struck through the point 7. If it now be examined by means of a narrow radial slit extending across the marked portion of the disk, the short lines intercepted will, by their pendulum-like motions, represent the motion of the air particles in a closed organ pipe giving its first overtone. When the slit is shortened so as to show only the portion of the

disk between the two nodal lines, the vibration of a rod clamped at both ends will be represented; whilst the outer half of the latter length of slit will represent similarly a closed organ pipe giving its fundamental note. In this way by restricting the slit to various parts of the disk, various vibrating rods of metal and organ-pipes can be represented.

The disks thus produced I have had very satisfactorily lithographed for students' use.

Should any of your readers be desirous of obtaining further information I shall be happy to oblige them.

F. CHESHIRE.

P.S.—In the drawing of the disk given the centre has been filled up by broken circles. As thus drawn the inner circle may with advantage be blackened over.

#### THE SCIENCE MUSEUM AND GALLERY OF BRITISH ART AT SOUTH KENSINGTON.

MOST people were under the impression that they had heard the last of the absurd proposal that the site in South Kensington, which had already been set apart for scientific purposes, should be appropriated for the British Art Gallery. After all, however, the scheme has not, it seems, been definitely abandoned. Mr. Tate is said to have decided that if this particular piece of land is not granted he will withdraw the offer of his pictures and of the money he is willing to give for the erection of a suitable building. Men of science, like other people, would be sorry if the nation lost the advantages which Mr. Tate wishes to confer upon it; but they are bound to protest strenuously against the notion that it is either right or expedient to try to promote the interests of art at the expense of those of science. The South Kensington site is urgently wanted for the purposes for which it has been promised. Careful investigation has shown that every foot of the land will be needed for an adequate Science Museum and for laboratories; and if Mr. Tate's idea is acted upon, irreparable injury will be done, not only to the Royal College of Science, but to the entire system of scientific training in England. It has been asserted that the land "was bought for science and art," and that, consequently, science has "no monopoly in it." The land was not bought for "science and art." It was bought for "science and the arts," by which were meant the industrial arts, the development of which directly depends on science. The whole difficulty is due to the haphazard way in which all that relates to science is treated by public authorities in this country. If England had possessed a Minister of Education, with powers corresponding to those which belong to the French or the Prussian Minister of Education, he would never have permitted this question to be even opened; and Mr. Tate would probably have obtained long ago a proper site elsewhere. Of course nothing that can be done to prevent an act of utter folly and injustice will be left undone in Parliament by the scientific members.

The following letter on the subject appeared in the *Pall Mall Gazette* on Wednesday, February 10:—

SIR,—Before Parliament and the public agree to the somewhat exacting terms which Mr. Tate appears to make a condition of his munificent donation, I would beg your leave to submit the following questions for their consideration:—

1. Why should he not be satisfied with the plot of ground, somewhat higher up the Exhibition Road, which is much larger than his contribution of £80,000 will cover with a decently-constructed building? The situation of that plot is in every respect better than the one he covets. It is adjacent to the East and West Galleries, which are already connected by a cross gallery. These galleries are, in the opinion of the most eminent artists in the country, the best galleries for the exhibition of pictures yet constructed in England, and in them the overflow from Mr. Tate's gallery might in future time find a home.

2. Why should the site which he asks for be cleared of the

Physical Laboratory and other portions of the College of Science already housed on it to interpolate an English Luxembourg between two portions of the Science School and Science Museum, relegating the latter to the aforesaid admirable picture galleries, which then for all time can never be annexed to the Tate Gallery, or even put in connection with it? Why, in fact, should the science instruction of the country be sacrificed to this collection of pictures, which is not of sufficient value to be accepted by the National Gallery? We hear a good deal of the French Luxembourg, but would any munificent donor of modern French pictures be allowed to have a slice out of the middle of the *École Polytechnique*, or of the *École Centrale*, or of the *Conservatoire des Arts et Métiers*, if, peradventure, that was the Naboth's vineyard which his heart craved for?

3. Why should the Government or the public suppose that if Mr. Tate's collection of pictures were inserted like a seton into the tissue of the College of Science it would have the effect of drawing a shower of gifts and bequests away from the rival establishment across the Exhibition Road, and only separated from it by a part of the College of Science? That rival establishment contains the Sheepshanks collection, given under stringent conditions to found, and accepted by the Government to found, a National Gallery of British Art. Other collections have been added—even since the Tate Gallery was in the air—on the same conditions. Intrinsicly and artistically they are worth probably ten times as much as the Tate collection. From the recent competition which has been held it is evident that the Government propose to spend a large sum of money in completing the South Kensington Museum, which will then be in a position to properly exhibit these and other bequests. It is well known that they cannot be sent to the Tate Gallery. They would be lost to the nation if an attempt were made to do so, the pious donors having taken ample precautions against such tricks being played with their gifts. Whatever pranks the Royal Academy may play with the Chantry Bequest, there is no reason to suppose that the British Museum or National Gallery pictures can be sent to increase the importance of this new establishment under an irresponsible management, which is not supported by a single artist of eminence, as far as I am aware.

4. Why should Government emulate the antics of the celebrated cow who kicked over the pail of milk she had just filled, and, having done more than any previous Government for technical instruction, make itself superbly ridiculous by dealing an irremediable blow to the advance of that instruction for the sake of Mr. Tate's £80,000? It must be remembered that there is no institution for the advancement of scientific instruction in the country similar to the College of Science with the Science Museum which it is now proposed to dismember for the sake of that £80,000.—I am, Sir, yours obediently,

London, February 9.

Y.

#### NOTES.

THE late Prince Louis Lucien Bonaparte has left to the Nation his valuable collection of metals, which is now in course of arrangement at the Science Museum, South Kensington. The collection is rich in specimens of the rarer metals. This bequest is the result of a promise made to Prof. Roberts-Austen, the Prince having been much interested in the Percy collection at South Kensington. The Prince's early papers, which were mainly chemical, comprised an account of a method of separating cerium from didymium; and he used to refer with pride to his having won admission to the ranks of the Legion of Honour by chemical research.

IN order to afford increased and improved accommodation for the departments of physics and mechanical and electrical engineering, the Council of University College, London, have decided to enter without delay upon a considerable extension of the College buildings. The addition to the College will form an important block opposite the east end of University Street, with an extension for some distance along the Gower Street front of the College grounds. It is to contain separate laboratories and lecture-rooms for mechanical engineering and electrical engineering, with rooms for engineering drawing, a

dynamo-room, and all else that is required for an efficient school of modern engineering. This extension will enable the basement and ground-floor of the central wing of the main building, together with a new building to be erected in the inner court, to be devoted to the department of physics, which has hitherto been very imperfectly provided for in rooms that were originally intended for quite other purposes than those to which they have been applied. The position of the new physical laboratory is such that it will be as far removed as is easily possible, in the heart of London, from heavy street traffic.

The death of the well-known botanical collector, B. Balansa, is recorded in the French journals. He died in the military hospital of Hanoi, Tongking, to which country he went on a second botanical expedition. Balansa was not merely a collector of plants; he was also a botanist, though he never published much, his principal contributions to botanical literature being on the grasses of New Caledonia and of Cochin China. He also published a botanical account of his ascent of Mount Humboldt in New Caledonia. But as a botanical collector, Mr. Balansa contributed to nearly all of the principal herbaria of Europe, having spent many years of his life collecting in Algeria, Morocco, Asia Minor, New Caledonia, Paraguay, Tongking, and other parts of the world. On Sir Joseph Hooker's recommendation he was attached as botanist to the Commission appointed in 1873 by the Paraguayan Government for the scientific exploration of its territory; and he spent three years and a half traversing the country in various directions for this purpose. He made very large botanical collections, but these, as well as his New Caledonian plants, have only been partially worked out. Kew purchased a set of about 2000 species.

ON Saturday last the members of a mountaineering and scientific expedition, under the leadership of Mr. W. M. Conway, sailed by the steamship *Ocampo* for Karachi, whence they will proceed, by way of Abbotabad and Kashmir, to the mountains of Baltistan, on the frontier of Eastern Turkistan. Their object is to explore thoroughly the high glacial area of the Karakoram range. One of their chief aims will be to make a special survey of the great Baltoro glacier, which descends from the peak "K 2" (28,265 feet), the second highest measured peak in the world. They will make scientific collections, and record observations of glacial phenomena. The Baltoro, Punmar, and Biafo glaciers, which unite their streams in the neighbourhood of Askoley, are believed to be the largest glaciers in the world outside of the Arctic and Antarctic regions, and their upper levels have never yet been explored. Mr. Conway is accompanied by the Hon. C. G. Bruce and Mr. J. H. Roundbush; and they are taking with them Mr. A. D. McCormick, the artist of the expedition; Mr. Oscar Eckenstein, a well-known Alpine climber; and Mathias Lurbriggén, of Macugnaga, one of the famous family of Alpine guides. It is understood that they intend to make a determined assault upon "K 2," or one of the loftiest of the neighbouring peaks, with a view to discovering whether the limit to which qualified mountaineers can climb has yet been attained. The expedition, it may be mentioned, has been subsidized both by the Royal Society and by the Royal Geographical Society.

A CRIMEAN Alpine Club has been formed at Odessa. The objects of the members are to explore the mountains of the Crimea, to publish scientific papers on phenomena connected with them, to protect rare species of plants and animals, to favour the development of agriculture, horticulture, and small local industries among the mountaineers, and to provide facilities for tourists, artists, and men of science who may desire to visit the region.

THE 1892 Photographic Conference will be held at the Society of Arts on Tuesday and Wednesday, March 22 and 23, under the presidency of Captain W. de W. Abney, F.R.S.

LAST week we mentioned the case of the miner Johann Latus, of Myslovitz, in Silesia, who had been asleep for over four months. The latest news about him is that he has partly recovered, and the cataleptic rigidity of the limbs, which was characteristic of his somnolent condition, has disappeared. It is curious to note that, although he has conversed with his wife, he seems quite unaware of the long stay he has made in the hospital. No feeling of pain of any sort has been experienced by him, and in fact he cannot recall any sensation during this long period. Dr. Albers, who is attending to him, hopes that he will soon completely recover. Unfortunately Latus has been threatened with inflammation of the lungs, which, view of his present weak state, might be fatal to him. He still continues to take only milk diet, having refused both meat and wine.

DR. G. SCHWEINFURTH has taken up his abode in the Italian colony on the Red Sea for the purpose of completing his investigation of the flora of Yemen and of Northern Abyssinia. He is accompanied by Dr. D. Riva, of Bologna.

PROF. L. H. BAILEY has been appointed special agent of the United States Weather Bureau for the purpose of making a report on phenology, and the relation of climate to the times of blooming, fruiting, and leafing of plants.

MR. WORTHINGTON G. SMITH reports that he has now made water-colour drawings of 492 species of British *Basidiomycetes*, including the whole of the white-spored species of *Agaricus*, for the public gallery in the Botanical Department of the British Museum. The total number of British *Basidiomycetes* is over 2000, and these are intended to be completed on 96 sheets. Closely-allied species are placed side by side, so that the salient points of differentiation can be seen at a glance.

THE fourth number of the Journal of the Leprosy Investigation Committee, just issued, presents much information on leprosy in Russia, Brazil, and Madeira. It contains also papers on the communicability of leprosy by vaccination, and various notes and abstracts. We learn from the Journal that the Report of the Leprosy Commission, together with an appendix containing the results of their laboratory work, is being printed in India, and will probably be ready for issue from the office of the National Leprosy Fund, in London, in a very few weeks.

THE people of Vienna have been greatly alarmed by the outbreak of a new epidemic, which is believed by some to be connected with the influenza. It affects the intestines, its symptoms being fever and acute colic, with the ejection of blood. Its appearance seems to indicate the absorption of some poisonous matter. At first it was attributed to the drinking-water, but this view has been generally abandoned. A representative of a Vienna newspaper has taken the opinion of some of the leading Vienna physicians on the subject. Prof. Nothnagel hesitated to pronounce any judgment on the nature of the illness, the facts not having been sufficiently studied. Prof. Drasche thought it might be "nothing else than a distinct form of influenza," and was confident that it was not due to the drinking-water. Prof. Oser was also sure that the drinking-water had nothing to do with the disease, and "did not consider that there was any indisputable evidence of its connection with influenza." Dr. Bettelheim seemed to think that there was something in common between influenza and the new malady called "catarrh of the intestines." He based his opinion on the fact that from the day when the latter made its appearance in an epidemic form cases of ordinary influenza had begun to decrease. He looked upon them both as being of an infectious nature. A chemical analyst, Dr. Jolles, said it would require three weeks to make a bacteriological inquiry into the character of the illness. A chemical analysis of the drinking-water showed it to be of normal purity.

AN appeal on behalf of the Polytechnic (Regent Street) Institute has been issued this week by Lord Reay, Lord Compton, Mr. Mundella, Sir Lyon Playfair, Dr. Gladstone, and other gentlemen, who have lately been appointed on the governing body. They have found the following condition of affairs:—Mr. Quintin Hogg has himself up to the present time paid all the deficiencies of the Institute, besides finding very large sums for constantly building and adding to the premises, amounting to in all about £150,000. Over £23,000 is contributed annually in fees, subscriptions, &c., by those who make use of the Institute, and £3500 is allowed by the City Charities Fund, but there still remains to be met a yearly deficit of £4000. The only way in which the governing body could curtail expense would be to close the Young Women's Institute and the large and numerous attended Art School. They are, of course, extremely reluctant to take this step; so they ask those who value the work done by the Polytechnic to provide a sum of £4000 per annum for three years. By that time, they trust, aid for technical education may be forthcoming from the London County Council. A donation of £500 for this year's expenses has been promised by Mr. J. Carnegie, and it may be hoped that the governing body will have the satisfaction of being able to meet the difficulty. As they point out, more students are now receiving technical education at the Polytechnic than were being so instructed in the whole of London before the institution was started; and there is not the slightest exaggeration in the statement that it would be difficult "to over-estimate the benefits which have accrued to the nation at large, and London in particular, from this branch alone of the Polytechnic work."

A COMPANY has presented to the Committee of Ways and Means in connection with the World's Fair, Chicago, a proposition which is likely to attract some attention. The company proposes to connect all the large cities of the United States by wires in such a manner that when the President presses the button for the official opening of the Exposition he will not only start in motion the machinery of the World's Fair, but will ring the fire bells and hoist the Stars and Stripes in every town in the country, and also open "the largest mechanical, electrical, and musical concert ever given on earth." According to the American journal *Electricity*, this is all to be done without cost to the Exposition management. Nothing is asked beyond the sanction of the management to the proposed idea, consent to proceed, and the assurance that a similar privilege will be given to no other person or company.

ACCORDING to a report recently published in Germany, there were, in 1889, 5260 workmen killed in accidents, and 35,392 seriously injured. These losses do not vary much from one year to another. M. Vacher, in *La Nature*, compares the figures with those of the killed and wounded at Gravelotte—one of the most murderous battles in this century—which were 4449 and 20,977. The industries furnishing most accidents are as follows, in descending order: mines, railways, quarries, subterranean works, building, breweries. All industries are arranged in 64 corporations, and it is estimated that more than 4½ millions of workpeople are insured. Wounds and fractures are the most usual form of injury, and the duration of treatment tends to increase every year, by virtue of a law which makes an allowance when incapacity for work exceeds three weeks (this was based on the observation that fractures were generally healed in three weeks). Since this law was introduced, the treatment of fractures has taken longer. There are always more accidents in winter than in summer, and on Mondays and Saturdays than on other days. Also there are twice as many accidents from 9 a.m. to noon, and from 3 to 6 p.m., than from 6 to 9 a.m., and from noon to 3 p.m. Better light in summer, and fatigue towards

the end of each half-day of six hours, are supposed to explain some of these variations.

IN the February number of *Nature Notes*, Mr. Robert Morley vouches for the accuracy of a story which seems to indicate the possibility of very tender feeling in monkeys. A friend of Mr. Morley's, a native of India, was sitting in his garden, when a loud chattering announced the arrival of a large party of monkeys, who forthwith proceeded to make a meal off his fruits. Fearing the loss of his entire crop, he fetched his fowling-piece, and, to frighten them away, fired it off, as he thought, over the heads of the chattering crew. They all fled away, but he noticed, left behind upon a bough, what looked like one fallen asleep with its head resting upon its arms. As it did not move, he sent a servant up the tree, who found that it was quite dead, having been shot through the heart. He had it fetched down and buried beneath the tree; and on the morrow he saw, sitting upon the little mound, the mate of the dead monkey. It remained there for several days bewailing its loss.

AT the meeting of the French Meteorological Society on Jan. 5, M. Janssen, in his Presidential address, said that meteorology was passing through a critical and interesting period of its history; it cannot fully render the important services expected of it until it has been sufficiently cultivated for its own sake, without reference to its application to other sciences, such as agriculture, &c. He could not too strongly recommend the more general use of photography for the registration of certain phenomena. Observations in balloons, and on mountain-stations, should be utilized as much as possible, as the latter will have a considerable effect on the progress of the science. He also urged the necessity of constructing self-registering instruments, working automatically for a lengthened period, owing to the difficulty of obtaining continuous records at the highest stations. M. H. Lasne made some remarks on the subject of a communication by M. Teisserenc de Bort at a previous meeting relating to barometric gradients. He thought that the representation of the surface isobars drawn in section in a conveniently chosen vertical plane, is of advantage from a graphical point of view, in order to show approximately the march of the phenomena. On the other hand, he was of opinion that, if calculations were introduced with a view to greater precision, there would be no longer any advantage in making use of the difference of height of the surface isobars.

GENERAL GREELY, Chief Signal Officer of the United States Army, has just issued a set of international monthly charts of mean barometric pressures and wind directions at about noon (G.M.T.) for 1882 and 1883, for a large part of the northern hemisphere. It will be remembered that this was the period at which special observations were made by the International Polar Expeditions. All the data available for the Polar regions have been used in the preparation of these charts, and they therefore contain more observations made within the Arctic Circle than any previous charts issued by the Signal Office. They show that the general features of barometric pressure in the Arctic regions are a principal minimum in July, followed by a principal maximum in November, with secondaries in January and April (or May) respectively. The author states that he has prepared, and hopes soon to publish, charts of the mean monthly pressures, as determined for the northern hemisphere from the international synchronous observations during ten successive years. He also expresses the hope that some of the meteorologists connected with the International Polar Expeditions will confirm or disprove the theory of a regular march of barometric pressure from month to month throughout the earth, and not simply to and from the oceans and interior of continents, with alternating summer and winter. The unravelling of the com-



plex conditions produced by the march of various types of pressure from one part to another is a necessary prelude of long-time weather predictions for large areas.

THE *Mediterranean Naturalist* for January prints some good notes, by Mr. J. J. Walker, R.N., on ants' nest beetles at Gibraltar and Tangier, with especial reference to the Histeridae. The search for ants' nest Hister is a somewhat troublesome employment, as only about 2 or 3 per cent. of the ants' nests contain the beetle. Mr. Walker, however, thinks "it is a pretty sight, and one which compensates for a great deal of strain to the eyes, as well as to the back, to see a *Sternocalis* or *Eretmotus* lying motionless among the hurrying crowd of ants, and then, suddenly developing an amount of leg quickness in so small a creature, marching off daintily on the tips of its toes (or rather tarsi) with a ludicrous resemblance, in its gait and appearance, to a tiny crab." The comparatively weak mandibles of the ants are ineffective against the hard armour and tightly packed limbs of the beetles, which devour the helpless brood with impunity. Mr. Walker has more than once taken *S. acutangulus* with a half-eaten larva in its jaws, and they are usually to be found clinging to the masses of larvæ where these lie thickest. On the other hand, he once (but once only) saw an ant take up a *S. arachnoides* in its mandibles and carry it off into a lower gallery of the nest; but this may have been done under the influence of alarm, the frightened ant seizing on the first object that came in its way.

A VALUABLE map is issued with the current number of the Proceedings of the Royal Geographical Society. It has been constructed by Mr. W. J. Turner, in accordance with instructions given by the Hon. George Curzon, who explains in a memorandum various matters connected with the work. The map, with the memorandum and an index to the positions of places, is to be bound in a handy form and published separately.

AN interesting paper on the Gran Chaco is contributed by Mr. J. Graham Kerr to the current number of the *Scottish Geographical Magazine*. Mr. Kerr visited the Gran Chaco in connection with the recent Pilcomayo Expedition. Most writers on the region have praised it in unmeasured terms; and this judgment, confined to the zone bordering the fresh-water rivers, is declared by Mr. Kerr to be perfectly just. This zone has the advantages of a beautiful climate, a magnificent deep alluvial soil, good drainage, and facility of access. Splendid forests of most valuable timber alternate with pastures of the richest quality. But the interior, and by far the larger part, of the Gran Chaco is totally different. The usual utter absence of fresh water, and the poorness of the soil and of the pastures, make the country unfit for the agriculturist or the stock-raiser, while timber is comparatively scarce. Mr. Kerr thinks that the Holywood and the *Cascarandá*, as timbers, and the *Uvira* as a textile plant, will probably be found almost the only productions of value in the interior.

THE "British Journal Photographic Almanac and Photographer's Daily Companion" for this year, edited by J. Traill Taylor, seems to have increased in bulk, and is as interesting as ever. The articles on the many and various subjects which are dealt with by the contributors are well worth perusal. The tables and the general information given in the volume are all that a photographer requires. The frontispiece, which is a likeness of William II., Emperor of Germany, is from a negative by Messrs. Russell and Sons, and is produced here on bromide paper, as an example of an average print.

MESSRS. GEORGE PHILIP AND SON have issued a valuable little book on "Technical Education in the Counties," by George J. Michell and Ernest Heber Smith. It is based on a series of articles which appeared last year in the *County Council Times*. The authors have had a large experience in teaching the classes

who will be specially affected by the new instruction provided by the Technical Instruction Act. After a general chapter on national education, they deal with special agricultural requirements, night science agricultural schools, the cost of secondary and night science and agricultural schools, higher agricultural schools, and agricultural colleges and universities. Among other subjects discussed are the requirements of mining districts, manufacturing and engineering requirements, and the educational needs of girls.

THE Cambridge University Press has issued a "Catalogue of the Type Fossils in the Woodwardian Museum, Cambridge," by Henry Woods, of St. John's College. Prof. T. McKenny Hughes contributes a preface.

MESSRS. J. B. BALLIÈRE ET FILS, Paris, have issued a French translation of ten well-known essays by Prof. Huxley. The volume is entitled "Les Problèmes de la Géologie et de la Paléontologie."

THE United States National Museum has published a paper, by Prof. E. D. Cope, on the characters of some Palæozoic fishes.

CHARLES LUNN'S "Philosophy of the Voice" has been translated into German by Herr Ludwig J. Trüg. A special value is given to this translation by various additions which have been made by Mr. Lunn himself.

TWO new compounds of carbon, chlorine, and bromine are described by M. Besson in the current number of the *Comptes rendus*. There are three possible chlorobromides of carbon— $\text{CCl}_3\text{Br}$ ,  $\text{CCl}_2\text{Br}_2$ , and  $\text{CClBr}_3$ . The first of these compounds,  $\text{CCl}_3\text{Br}$ , was obtained some time ago by Messrs. Friedel and Silva, by heating bromine and chloroform together in sealed tubes to 170° C. M. Besson now shows that this reaction, when carried further at higher temperatures, yields all three chlorobromides, which may readily be separated by fractional distillation. The mixture of bromine and chloroform, in the proportion of two atoms of the former to each molecule of the latter, is best heated in a sealed tube first for two hours at 225°. The end of the tube is then softened in the blow-pipe flame, in order to permit of the escape of the hydrobromic acid which is evolved during the first stage of the reaction. The tube is then closed, and again heated, this time to 250°, after which it is reopened, and the pressure of gas, which is now mainly hydrochloric acid, released. The tube is finally closed, and heated to 275°, at which temperature the reaction is complete. By proceeding in this manner, the risk of the tube being fractured by the enormous pressure of the evolved hydrobromic and hydrochloric acids is minimized. The explanation of the formation of all three chlorobromides is probably as follows. The bromine first reacts with the chloroform with production of the direct substitution products,  $\text{CCl}_3\text{Br}$  and  $\text{CCl}_2\text{Br}_2$ , according to the equations

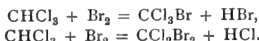

Subsequently, at a higher temperature, the hydrobromic acid reacts upon the compound  $\text{CCl}_2\text{Br}_2$ , producing  $\text{CClBr}_3$  and hydrochloric acid,

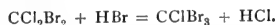

It would doubtless be more profitable to complete the whole reaction at once by heating to 250° if glass tubes were capable of withstanding the pressure, but M. Besson finds that they invariably burst if this is attempted. Upon fractionally distilling the product of the reaction, three fractions are obtained. The first, boiling at 103–105°, consists of  $\text{CCl}_3\text{Br}$ ; the second, which distils constantly at 135° and usually solidifies in the receiver, consists of  $\text{CCl}_2\text{Br}_2$ ; the third fraction, consisting of  $\text{CClBr}_3$ , boils at 160°, and rapidly solidifies as it condenses. The first

chlorobromide,  $\text{CCl}_2\text{Br}$ , is a clear liquid which crystallizes when cooled to  $-21^\circ$ . The compound  $\text{CCl}_2\text{Br}$  is a solid at the ordinary temperature, crystallizing in fine needles; it melts, however, to a clear liquid at  $22^\circ$ , and distils without decomposition at  $135^\circ$ . The density of the liquid at  $25^\circ$  is 2.42. It is endowed with an odour recalling that of chloroform, and, like the latter liquid, volatilizes rapidly at ordinary temperatures, its vapour tension at  $16^\circ$  being equal to 21 millimetres of mercury. The third chlorobromide,  $\text{CClBr}_2$ , is readily soluble in ether, from which it crystallizes upon cooling in the form of transparent tabular crystals of specific gravity 2.71 at  $15^\circ$ , and which fuse at  $55^\circ$ . When distilled it suffers a slight amount of decomposition, a little bromine vapour being liberated. Its odour very much resembles that of carbon tetrabromide. It is very soluble in chloroform and carbon tetrachloride, but is much more difficultly soluble in alcohol.

The additions to the Zoological Society's Gardens during the past week include a Green Monkey (*Cercopithecus callitrichus*  $\delta$ ) from West Africa, presented by Mr. W. E. Tandy; a Black-eared Marmoset (*Hapale penicillata*) from South-East Brazil, presented by Mr. Harley M. Usill; two Herring Gulls (*Larus argentatus*), British, presented by Mr. T. A. Cotton, F.Z.S.; a Dwarf Chameleon (*Chamaleon pumilus*) from South Africa, presented by Captain J. C. Robinson; a Tabuan Parrakeet (*Pyrhulopsis tabuan*) from the Fiji Islands, received in exchange; six Dingos (*Canis dingo*), born in the Gardens.

#### OUR ASTRONOMICAL COLUMN.

REPORT OF THE U. S. NAVAL OBSERVATORY.—The Annual Report of the Superintendent of the U. S. Naval Observatory for the year ending June 30, 1891, has just been received. Prof. Hall has been using the 26-inch equatorial for observations of double stars, and his results will soon be reduced and published in a catalogue. The transit circle has been employed by Prof. Eastman in observations of the sun, moon, and planets, and stars necessary for clock and instrument corrections. Prof. Frisby has charge of the 9.6-inch equatorial, and has made a number of observations of comets, asteroids, occultations of stars by the moon, and the transit of Mercury which occurred on May 9, the first and second contacts being successfully observed. The photographs of the transit of Venus in December 1882 have been reduced and discussed, but the whole of the work in connection with the determination of the solar parallax is not yet completed. The solar eclipse of April 15, 1893, occurs under very favourable conditions, and Captain McNair hopes that every advantage will be taken of this circumstance. We note that on two nights a week the 9.6-inch equatorial is set apart for the accommodation of visitors. During the period covered by this Report 2360 persons availed themselves of this privilege.

OBSERVATIONS OF NEBULÆ AND STAR-CLUSTERS.—In 1884, M. Bigourdan began to make micrometric measures of nebulae observable at Paris, and a portion of his work, containing positions of nebulae and star-clusters between  $15^h$  and  $16^h$  of right ascension, has recently been published. As an introduction, a brief account is given of the growth of the idea that nebulae represent an important stage in the development of celestial species; and it is pointed out that measures such as those made at Paris will enable any proper motion to be determined. If successive careful measures should fail to show any proper motion, numerous observations of the motion of nebulae in the line of sight will furnish data for the determination of the minimum distance of these bodies from the earth. M. Bigourdan next traces the gradual increase in the number of nebulae recorded, going back to the "Almagest," in which Ptolemy mentions six. Precise observations are said to commence with Messier, and it is estimated that the co-ordinates of about 1500 nebulae are now accurately known. At Paris the positions of nebulae have been determined relatively to certain comparison-stars by the method usually adopted for comets; the difference *neb.*-\* being found in right ascension by the difference in the times of transit, and in declination by micrometric measures. The instrument employed in the work has an aperture of 0.32

metres, and a focal length of 5.20 metres. The tabulated observations are made up of eighteen columns. First the N.G.C. number is given, and then the name of the discoverer and the date of observation. After this, the magnitude of the nebula is indicated. A nebula, just visible with the instrument employed, is assigned the magnitude 13.5; this number representing the faintest star that it can grasp. The majority of nebulae observed have magnitudes comprised between 13.2 and 13.5. The state of the sky at the time of observation has, of course, been recorded, and another number is tabulated to indicate the relative ease with which the nebula could be measured. This brief outline of the Catalogue is a sufficient testimony of the care with which M. Bigourdan has done his work, so far as it goes. It is to be hoped that the publication of the completed Catalogue is not very far ahead.

SOLAR OBSERVATIONS.—Prof. Tacchini, in *Comptes rendus* for January 25, gives the following *résumé* of solar observations made at the Royal Observatory of the Roman College during the last quarter of 1891:—

1891.	Number of days of observation.	Relative frequency		Relative magnitude		No. of groups per day.
		of spots.	of days without spots.	of spots.	of faculae.	
October	26	15.54	0.00	54.69	85.77	4.96
November	22	12.50	0.00	61.38	51.50	3.41
December	18	8.57	0.00	42.18	35.36	2.68

A comparison of these numbers with those for the preceding quarter shows a slight diminution in the phenomena of spots and faculae. It should, however, be remarked that on no day has the sun been free from spots, and the frequency of groups remains about the same.

The observations of solar prominences are summed up as follows:—

1891.	Number of days of observation.	Mean number.	Mean height.	Mean extension.
October	22	9.82	43.6	1.7
November	15	5.73	35.4	1.6
December	21	6.48	40.2	2.2

Prominences were frequently observed in September and also in October, but since this month the number has slightly diminished. The mean number for the quarter covered by this *résumé* is about the same as that of last quarter.

M. Marchand gives the results of solar observations made at Lyon Observatory during the latter half of 1891, in the current *Comptes rendus*. The proportion of spotted surface, expressed in millionths of the sun's visible hemisphere, and the surface covered by faculae expressed in thousandths of the visible hemisphere, is stated as follows:—

	Spots.	Faculae.		Spots.	Faculae.
July	1696	38.2	October	1180	49.6
August	957	40.5	November	748	39.2
September	2469	51.3	December	947	50.0

The total spotted surface is thus 7999 millionths of the visible hemisphere, this being covered by 101 groups. The preceding half year's observations gave 65 groups and a surface of 3517 millionths. Spots have been more numerous in the northern than in the southern hemisphere in the ratio 69:32. This predominance of activity in the northern hemisphere also holds good for faculae. The total surface covered by groups of faculae is 268.8 thousandths of the visible hemisphere, as against 1363 thousandths in the first six months of last year. The number of groups of faculae giving these values was 152 (July to December) and 131 (January to June).

MEASURES OF THE NEBULA NEAR MEROPE.—*Astronomische Nachrichten*, No. 3074, contains an account of some measures of the faint nebula discovered by Mr. Barnard close to the bright star Merope, in the Pleiades. The measures were made by Mr. S. W. Burnham with the 36-inch equatorial. The position-angle and distance found by Mr. Burnham are,  $166^\circ.3$  and  $36''.10$  (1891.71). These values agree very well with the values  $165^\circ.8$  and  $36''.85$  (1890.92) deduced from Mr. Barnard's observations of the differences of R.A. and Decl. between the star and the nebula. This extremely close association of a faint nebula with a bright star is most remarkable; and it will be interesting to determine, by careful measures in the future, whether the patch of nebulosity is drifting through space with Merope and the other members of the Pleiades group.

JOURNEYS IN THE PAMIRS AND ADJACENT COUNTRIES.

THIS was the subject of the paper read at the meeting of the Royal Geographical Society, on Monday, by Captain F. E. Younghusband. The author described two journeys, one in 1889 across the Kárákorum and into the Pamir, the other in 1890 to Yarkand and Kashgar, and south to the Pamirs again.

"The country," he said, "which I now wish to describe to you is that mountainous region lying to the north of Kashmir, which from the height, the vastness, and the grandeur of the mountains, seems to form the culminating point of Western Asia. When that great compression in nature took place this seems to have been the point at which the great solid crust of the earth was scrunched and crushed together to the greatest extent, and what must have formerly been level peaceful plains such as we see to the present day on either hand, in India and in Turkistan, were pressed and upheaved into these mighty mountains, the highest peaks of which are only a few hundred feet lower than Mount Everest, the loftiest point on this earth. It was amongst the peaks and passes, the glaciers and torrents of this awe-inspiring region, and anon over the plain-like valleys and by the still, quiet lakes of the Pamirs that my fate led me in the journeys which I have now come before you to describe."

Starting from Leh, in Ladak, Captain Younghusband's first objective point was Shahidula. This place is situated on the trade route to Yarkand, and is 240 miles distant from Leh. This he left on September 3, to explore the country up to the Tagh-dum-bash Pamir.

The route now led up the valley of a river, on which were several patches of fine grazing, and till last year this had been well inhabited, but was now deserted on account of Kanjuti raids. The valley is known by the name of Khál Chuskún. Chuskún in Turki means resting-place, and Khál is the name of a holy man from Bokhara, who is said to have rested here many years ago. The mountains bounding the north of this valley are very bold and rugged, with fine upstanding peaks and glaciers; but the range to the south, which Hayward calls the Aktágh Range, was somewhat tame in character, with round mild summits and no glaciers. The Sokhbulák is an easy pass, and from its summit to the east could be seen the snowy range of the western Kuenlun Mountains, while to the west appeared a rocky mass of mountains culminating in three fine snowy peaks which Hayward mistook as belonging to the main Mustagh Range, but which in fact in no way approach to the height and magnificence of those mountains, and really belong to the Aghil Range, which is separated from the Mustagh Mountains by the valley of the Oprang River.

On September 11, the party crossed the remarkable depression in the range which is known as the Aghil Pass.

"From here is obtained one of the grandest views it is possible to conceive; to the south-west you look up the valley of the Oprang River, which is bounded on either side by ranges of magnificent snowy mountains, rising abruptly from either bank, and far away in the distance could be seen the end of an immense glacier flowing down from the main range of the Mustagh Mountains. This scene was even more wild and bold than I had remembered it on my former journey, the mountains rising up tier upon tier in a succession of sharp needle-like peaks bewildering the eye by their number, and then in the background lie the great ice mountains—white, cold, and relentless, defying the hardest traveller to enter their frozen clutches. I determined, however, to venture amongst them to examine the glaciers from which the Oprang River took its rise, and leaving my escort at the foot of the Aghil Pass, set out on an exploration in that direction. The first march was easy enough, leading over the broad pebbly bed of the Oprang River. Up one of the gorges to the south we caught a magnificent view of the great peak K 2, 28,278 feet high, and we halted for the night at a spot from which a view of both K 2 and of the Gushirbrum peaks, four of which are over 26,000 feet, was visible. On the following day our difficulties really began. The first was the great glacier which we had seen from the Aghil Pass; it protruded right across the valley of the Oprang River, nearly touching the cliffs on the right bank; but fortunately the river had kept a way for itself by continually washing away the end of the glacier, which terminated in a great wall of ice 150 to 200 feet high. This glacier runs down from the Gushirbrum in the distance towering up to a height of over 26,000 feet. The passage round the end of the glacier was not unattended with danger, for the stream

was swift and strong, and on my own pony I had to reconnoitre very carefully for points where it was shallow enough to cross, while there was also some fear of fragments from the great ice-wall falling down on the top of us when we were passing along close under it. After getting round this obstacle we entered a gravel plain, some three-quarters of a mile broad, and were then encountered by another glacier running across the valley of the Oprang River. This appeared to me to be one of the principal sources of the river, and I determined to ascend it. Another glacier could be seen to the south, and yet a third coming in a south-east direction, and rising apparently not very far from the Kárákorum Pass. We were, therefore, now in an ice-bounded region, with glaciers in front of us, glaciers behind us, and glaciers all around us. Heavy snow-clouds too were unfortunately collecting to increase our difficulties, and I felt that we should have a hard task before us. On first looking at one of these glaciers it would appear impossible to take ponies up them, but the sides are always covered with moraine, and my experience in the exploration of the Mustagh Pass in 1887 showed that by carefully reconnoitring ahead, it was generally possible to take the ponies for a considerable distance at least up such glaciers; and as the one we had now reached seemed no worse than others, and there appeared a gap in the range which looked as if it might be a pass, I took my ponies on, and after three days' scrambling on the ice, reached the foot of the supposed pass, and started at 3.30 on the following morning to find if it was at all practicable.

Captain Younghusband was, however, obliged to return after reaching a height of 17,000 feet, and he decided to return to his camp on the Oprang River. He thus describes the glaciers from which this river takes its rise:—

"The length of this glacier is 18 miles, and its average breadth half a mile; it is fed by three smaller glaciers on the west and one on the east. At its upper part, immediately under the pass, it is a smooth undulating snow-field about a mile and a half in width. Lower down this *névé* is split up into crevasses, which increase in size the further down we get. Then the surface gradually breaks up into a mass of ice-domes, which lower down become sharp needle-like pinnacles of pure white ice. On each side lateral gravel moraines appear, and other glaciers join, each with its centre of white ice-peaks and its lateral moraines, and preserving each its own distinct course down the valley, until some three miles from its termination in the Oprang River, when the ice-peaks are all melted down and the glacier presents the appearance of a billowy mass of moraine, and would look like a vast collection of gravel heaps, were it not that you see, here and there, a cave or a cliff of ice, showing that the gravel forms really only a very thin coating on the surface, and that beneath is all pure solid ice. This ice is of opaque white, and not so green and transparent as other glaciers I have seen, and the snow at the head of the glacier was different from any I have seen before; for beneath the surface, or when it was formed into lumps, it was of the most lovely pale transparent blue. I must mention, too, that every flake of snow that fell in the storm was a perfect hexagonal star, most beautiful and delicate in form. The mountains on either side of the valley, especially on the eastern side, are extremely rugged and precipitous, forming little or no resting-place for the snow, which drains off immediately into the glacier below. The western range, the main Mustagh Range, was enveloped in clouds nearly the whole time, and I only occasionally caught a glimpse of some peak of stupendous height, one of them, the Gushirbrum, over 26,000 feet, and others 24,000 feet. The snowfall on these mountains must be very considerable, and it seems that this knot of lofty mountains attracts the great mass of the snow-clouds, and gets the share which ought to fall on the Kárákorum, while these latter, being lower, attract the clouds to a less degree, and are in consequence almost bare of snow."

After some further exploration of the glaciers, rivers, and passes in this wild region, Captain Younghusband returned to India by way of Kashmir. In the summer of 1890, he once more made his way northwards through Kashmir, with a companion, Mr. Macartney. They reached Yarkand on August 31.

"After a rest of two or three weeks at Yarkand," Captain Younghusband went on to say, "Macartney and I left our companions and started for a trip round the Pamirs. Approaching this interesting region from the plains of Kashgaria, one sees clearly how it has acquired the name of Bam-i-dunya, or Root of the World. The Pamir Mountains rise apparently quite suddenly out of the plain from a height of 4000 feet above sea-

level at their base to over 25,000 feet at their loftiest summits—a massive wall of rocks, snow, and ice. Mounting this wall the traveller comes on to the Bam-i-dunya, which would perhaps be better translated as the ‘upper story’ of the world. Houses in Turkistan are flat-roofed, and you ascend the outer wall and sit out on the roof, which thus makes an upper story, and it appears to me that it was in this sense that the Pamir region was called the Roof of the World. The name, indeed, seems singularly appropriate, for once through the gorges which lead up from the plains, one enters a region of broad open valleys separated by comparatively low ranges of mountains. These valleys are known as Pamirs—Pamir being the term applied by the natives of those parts to a particular kind of valley. In the Hindu Kush and Himalayan region the valleys as a rule are deep, narrow, and shut in. But on the Roof of the World they seem to have been choked up with the *Albris* falling from the mountains on either side, which appeared to me to be older than those further south, to have been longer exposed to the wearing process, and to be more worn down—in many parts, indeed, being rounded off into mere mounds, reminding one very much of Tennyson’s lines:—

“The hills are shadows, and they flow  
From form to form, and nothing stands;  
They melt like mist; the solid lands,  
Like clouds they shape themselves and go.”

The valleys have thus been filled up faster than the rainfall has been able to wash them out, and so their bottoms are sometimes as much as four or five miles broad, almost level, and of considerable height above the sea. The Tagh-dum-bash Pamir runs as low as 10,300 feet, but on the other hand, at its upper extremity the height is over 15,000 feet; and the other Pamirs vary from twelve or thirteen to fourteen thousand feet above sea-level. That is, the bottoms of these Pamir valleys are level with the higher summits of the Alps.

“As might be expected, the climate is very severe. I have only been there in the autumn, and can therefore speak from personal experience of that season only; but I visited them in three successive years, and have seen ice in the basin of my tent in August. I have seen the thermometer at zero (Fahrenheit) at the end of September, and 18° below (that is, 50° of frost) at the end of October. The snow on the valley bottoms does not clear away before May is well advanced. June and July and the beginning of August are said to be pleasant, though with chilly nights; and then, what we in England might very justly call winter, but which, not to hurt the feelings of the hardy Kirghiz who inhabit these inhospitable regions all the year round, we will, for courtesy’s sake, call autumn, commences.”

Captain Younghusband and Mr. Macartney advanced up those long gravel desert slopes which lead out of the plains of Turkistan, and then through the lower outer ranges of hills covered with a thick deposit of mud and clay, which Captain Younghusband believes to be nothing else than the dust of the desert, which is ever present in the well-known haze of Turkistan, deposited on the mountain-sides; then over the Kara-dawan, Kizil-dawan, and Torat Passes; through the narrow defile known as the Tangitar, where one has to force the ponies up a deep violent stream rushing over huge boulders between precipitous rocky cliffs, in which they noticed large square holes pierced, suggesting to them that in former days this, the high road between Eastern and Western Asia, was probably improved by having a bridge over this difficult and dangerous part; then over the Chichiklik and Koh-mamak Passes and the Tagarma Plain, till they reached the neighbourhood of Tash-kurgan, the northernmost point of Captain Younghusband’s explorations in the previous year. Passing through the Little Pamir, they struck the Alichur Pamir near Chadir-tash at its eastern extremity, and from there they looked down a broad level valley, averaging four or five miles in width, to some high snowy peaks overhanging Lake Yeshil-kul at its western extremity. The range bounding this Pamir on the north is free of snow in summer, but that separating it from the Great Pamir is of considerable height, the summits are always covered with snow, and the passes across it difficult. Traces of ancient glaciers are very frequent, and the western end near Lake Yeshil-kul is choked up with their moraines, forming a sea of gravel mounds, in the hollows of which numerous lesser lakes may be seen. On the borders of Yeshil-kul, at a place called Somatash, Captain Younghusband found the fragments of a stone bearing an ancient inscription in Turki, Chinese, and Manchu. This interesting relic, as far as Captain Younghusband has been able to get the rubbings he

took of it translated, refers to the expulsion of the two Khojas from Kashgar by the Chinese in 1759, and relates how they were pursued to the Badakhshan frontier.

From the Ak-su Valley the two travellers ascended the sterile valley of the Ak-baital, which at this season of the year (October) has no water in it, and visited Lake Rang-kul. “On the edge of this lake is a prominent outstanding rock, in which there is a cave with what appears to be a perpetual light burning in it. This rock is called by the natives Chiragh-tash, *i.e.* the Lamp Rock, and they account for the light by saying that it comes from the eye of a dragon which lives in the cave. This interesting rock naturally excited my curiosity. From below I could see the light quite distinctly, and it seemed to come from some phosphorescent substance. I asked the Kirghiz if any one had ever entered the cave, and they replied that no one would dare to risk the anger of the dragon. My Afghan orderly, however, had as little belief in dragons as I had, and we set off to scale the cliff together, and by dint of taking off our boots and scrambling up the rocks, very much like cats, we managed to reach the mouth of the cave, and on gaining an entrance found that the light came neither from the eye of a dragon nor from any phosphorescent substance, but from the usual source of light—the sun. The cave, in fact, extended to the other side of the rock, thus forming a hole right through it. From below, however, you cannot see this, but only the roof of the cavern, which, being covered with a lime deposit, reflects a peculiar description of light. Whether the superstitious Kirghiz will believe this or not I cannot say, but I think the probability is that they will prefer to trust to the old traditions of their forefathers rather than the wild story of a hare-brained stranger. The water of Rang-kul is salt, and the colour is a beautiful clear blue. The mountains in the vicinity are low, rounded, and uninteresting, though from the eastern end a fine view of the great snowy Tagarma Peak may be obtained.”

The winter was spent in Kashgar. On July 22, 1891, Captain Younghusband left to return to India by way of the Pamirs and Gilgit.

“On reaching the Little Kara-kul Lake, a piece of interesting geography, which I believe had been first noticed by Mr. Ney Elias, on his journey through these parts some years ago, presented itself. Captain Trotter, of the Forsyth mission, saw from the plains of Kashgar a stupendous peak, the height of which he found to be 25,300 feet, and the position of which he determined accurately. From Tash-kurgan or its neighbourhood he also saw a high mountain mass in the direction of the peak he had fixed from near Kashgar; bad weather prevented his determining the position of this second peak, but he thought there was no doubt that the two were identical. Such, however, is not the case. There are two peaks, about 20 miles apart, one on either side of the Little Kara-kul Lake. That seen from Tash-kurgan is the true Tagarma Peak, and cannot be seen from Kashgar; while that seen from Kashgar cannot be seen from Tash-kurgan. There appeared to me to be very little difference in height between the two. Both are remarkable not only for their extraordinary height, but also for their great massiveness. They are not mere peaks, but great masses of mountain, looking from the lake as if they bulged out from the neighbouring plain; and one sees far more distinctly than is usually the case, the layers upon layers of rock which have been upturned like the leaves of a book forced upwards. It struck me too, especially from the appearance of the rocks in the neighbourhood of the northernmost peak, that these must have been upheaved far more recently than the worn-out-looking mountains in the centre of the region of the Pamirs. The appearance of these two great mountain masses rising in stately grandeur on either side of a beautiful lake of clear blue water is, as may be well imagined, a truly magnificent spectacle, and, high as they are, their rise is so gradual and even, that one feels sorely tempted to ascend their maiden summits and view the scene from the loftiest parapets of the ‘Roof of the World.’”

On October 4, Captain Younghusband and a companion left the Tagh-dum-bash Pamir to explore “an interesting little corner of Central Asia, the point where the two watersheds—the one between the Indus on the south and the Oxus and Eastern Turkistan rivers on the north, and the other between the Oxus on the west and the eastern Turkistan rivers on the east—join. If any point can be called the Heart of Central Asia I should think this must be it. Here on the Oxus side of the watershed are vast snowfields and glaciers, and among these, with three of its sides formed of cliffs of ice—the terminal walls of glaciers—we found

a small lake, about three-quarters of a mile in width, out of which flowed the stream which joins the Panja branch of the Oxus at Bozai-Gumbaz."

After this Captain Younghusband made his way down to Kashmir.

### THE INSTITUTION OF MECHANICAL ENGINEERS.

ON Thursday and Friday evenings of last week, the 4th and 5th inst., the Institution of Mechanical Engineers held its forty-fifth annual general meeting in the theatre of the Institution of Civil Engineers, lent for the purpose by the Council of the latter Society, according to custom.

The first business was the reading of the annual report of the Council, from which it appears that the Institution continues to prosper, both in regard to finances and membership. The accumulated surplus now amounts to about £36,000, and is increasing at the rate of over £2000 per annum. At the end of last year the number of names of all classes on the roll of membership amounted to 2077, a net gain of 134 on the previous year.

The following two papers were read and discussed:—

(1) Notes on mechanical features of the Liverpool Water-works, and on the supply of power by pressure from the public mains, and by other means, by Joseph Parry, water engineer, Liverpool.

(2) On the disposal and utilization of blast-furnace slag, by William Hawdon, of Middlesbrough.

The first paper was chiefly valuable as recording an attempt of the Liverpool Corporation, who control the water supply of the city, to establish a system of power distribution by means of the ordinary mains. The Liverpool water supply is chiefly interesting at the present time from the fact that the Vyrnwy works and connections are all but complete. When this system is in operation the Liverpool mains will carry a pressure of water obtained by a natural head, due to the source of supply being in the higher land of North Wales. At present there are in active duty, in connection with the Liverpool Water-works, some fine examples of veteran pumping-engines. There is a Cornish engine and boiler erected at the Windsor station in 1840; a crank engine made in 1837; and a fine old Cornish pumping-engine and boiler made by the celebrated firm of Harvey and Co., of Hayle, in Cornwall. The cylinder of the latter is 50 inches in diameter, with a 9-foot stroke, and is steam-jacketed. The pump is 17½ inches in diameter by 8 feet 9 inches stroke. The average boiler pressure is 35 pounds per square inch. Since this engine began its career it has lifted 18,854 million foot-tons of water. By a recent trial its duty was found to be 55·7 millions of foot-pounds per cwt. of coal. The indicated horse-power is about 86. The figures serve to show that, in spite of higher pressures and quicker piston-speeds, now so much talked of, not so much advance has been made in the economy of big engines as one might be led to suppose from the efforts that are made to introduce three and four stage compounding, and the virtues that are attributed to it. The average rate of water supply of Liverpool per head per day is about 24½ gallons, and the water is distributed on the constant service system. Mr. P. Howden's figures as to cost of various systems of power supply are valuable, but they would have been rendered still more so had he taken the further trouble of introducing a more orderly system of classification, and had he given, in one or two instances, fuller information as to the elements upon which he had based his calculations. However, we must not look our gift horse too curiously in the mouth, and any information on one of the great problems of the hour—common power supply from central stations—is to be made the most of at present. No doubt civilization has lagged behind somewhat in this respect. Power "laid on" in our houses might be as much a matter of course as the bringing of gas and water to us by automatic means; and doubtless this would do something towards solving that other great problem of the hour—and most other hours—the domestic servant problem. At present nearly all large buildings in London, and still more so in America, have a fairly large power installation in their basements. The number of steam boilers that are hidden away among the foundations of large hotels, clubs, and stacks of offices would surprise many people not familiar with these matters. All this involves some waste of room and some waste

of energy. In New York a few months ago an effort was made to solve the problem of power distribution by generating steam in a gigantic battery of boilers in one central station, and running the steam pipes all over the city; so that one had only to open a valve and the steam engine could be started forthwith. The scheme was not altogether a success. After a very short time New Yorkers were disagreeably surprised by artificial geysers and mud fountains springing up in the middle of some of the most frequented thoroughfares. A great outcry was raised, and for some time it seemed as if popular indignation would compel the company to stop their work. We believe, however, that there have been improvements lately, but it does not seem probable that steam, conveyed in pipes, will be the means by which power distribution will find its solution in England. Compressed air possesses strong advocates, and in Paris the Popp system, originally devised simply for working clocks from a common centre, has proved a success. In England, however, we have the recent failure at Birmingham, where much money has been spent and many disappointments caused by an endeavour to supply compressed air for power purposes in the city, which, perhaps, of all others in the world, offers the most promising field for such an enterprise. The Hydraulic Power Company has proved a success in London, and its ramifications extend over a wider area than most people imagine; but here, we think, the enterprise finds by far its greatest outlet simply in working elevators and lifts. The gas companies are the largest distributors of power. Perhaps the keenest struggle for lighting and supplying domestic power will be between gas and electricity. The latter has the advantage, from a power point of view, that the motor is clean, compact, odourless, and comparatively noiseless. There is no denying that the gas-engine is not a pleasant neighbour. It is also difficult to start, and requires a large water supply; it smells badly, and makes a noise. On the other hand, it is far cheaper than electricity. Mr. Parry, in his paper, gives an instance of a gas-engine working a hoist in Liverpool at the cost of one-third of a penny per indicated horse-power per hour, and this we should not class as a low figure by any means; whilst Sir James Douglass stated that the charge made for the same unit of power by the Liverpool Electric Supply Company was 5d. per hour. There is one other source of power which is yet in its extreme infancy, but of which, we think, much will be heard before long. That is the oil-engine. It cannot be brought into the category of power distribution, however, as each motor of this kind must work on its own bottom. For country districts and isolated positions, at any rate, it offers great promise, and will assuredly take a prominent position when the mechanical details have been brought to a higher state of perfection. The chief interest in Mr. Parry's paper centres in the tables giving figures as to cost. These may be briefly summed up in the statement that when water at high pressure (700 pounds) can be bought for 5s. per thousand gallons, water power at average domestic pressure (50 to 70 pounds) cannot compete with it. Whether high pressure water will be able to beat electricity and gas is a problem the solution of which is hidden in the future; and doubtless all the systems mentioned have advantages peculiar to them which would give each in turn the preference under given conditions. Hydraulic distribution has a great point in its favour when the exhaust-water can be used for other purposes.

The disposal of blast-furnace slag would not appear a very interesting question to the uninitiated, but it is really a very important matter. In Great Britain the iron-masters of the country produce annually 12,000,000 tons of this all but unused material. It is the refuse of iron-smelting, and it may be added that this annual supply of waste matter absorbs, and radiates uselessly into space, heat units which require for their production 653,000 tons of coal. A very small part of this slag is applied to any useful end; by far the greater quantity of it simply cumbars the ground, or necessitates the spending of large sums in carrying it out to sea. Of course, iron cannot be made without producing slag. To smelt the ore limestone has to be used in order to separate the various impurities with which it is blended. In this way the slag is produced, and the purer metal is obtained. Mr. Hawdon has devised a machine by which he claims to have facilitated the removal and utilization of the slag. In general principle it is not altogether novel, but it possesses some features which, its inventor claims, render its working a success, whereas failure has hitherto accompanied such efforts. In the blast furnace the molten slag separates from molten

iron in consequence of the difference in specific gravity of the two. When the furnace is tapped, the iron runs off to the pig-bed to be cast into the well-known form. The slag is usually run into boxes, which are mounted on wheels. The passion for bigness which in the present day characterizes nearly all engineering operations of this nature, has extended to slag handling, so that a box will sometimes hold as much as four tons of slag. When the mass is sufficiently cool to stand alone the sides of the mould are lifted off by a crane, and the bogie is drawn away to the "tip," or "slag mountain," by a locomotive. As the land covered by the "tip" is often very valuable, in some localities being worth as much as £1000 per acre, it is desirable for this reason alone that the slag should be dealt with in some other way. When the iron-works have a sea outlet, the slag is often taken away in vessels constructed for the purpose, and dropped in deep water. The difficulty here is that the big lumps, or "slag-balls," are difficult to handle. To lower them gently into the barge is too costly, and if they are shot in they are likely to start the rivetting. Hand-breaking was, therefore, had recourse to—a tedious and costly process. In order to overcome this difficulty, an ingenious plan, known as the dry core system, has been devised. A hollow iron casting was placed so that the slag would flow round it when run in the mould. This was done so that the slag in cooling would contract round the casting and break up into pieces small enough to be tipped into the barge without injury to the plates and rivetting. Mr. Hawdon has not found this method to be successful; but it is stated that others have followed the plan with advantage. In America a method known as "slopping" is used, and undoubtedly with success. The molten slag is run on to a surface, and a large but comparatively thin cake is so obtained. When this layer is sufficiently cool, another is formed above it, and then other layers, so that the whole forms a stratified mass, with planes of demarcation between. Such a body is broken up with comparative ease. Sometimes the slag is taken away in the molten state in "boats" which are simply tanks on wheels. It is then poured away, leaving a problem for the engineers, and perhaps the geologists, of future generations to solve. There have been other methods of dealing with slag, but these we have not space to describe. Mr. David Joy, a well-known mechanical engineer, took the matter up about twenty years ago, and spent a year or two upon the problem. Some of the devices he originated were extremely ingenious, but for reasons of a commercial nature, his efforts were not continued. There are some uses for furnace slag. It is made into bricks, it is drawn into slag-wool, it is made into cement, and is broken up for ballasting railways, pitching streams, or, when made into concrete, for harbour and breakwater works. In spite of these uses, the great bulk of the 12,000,000 tons produced each year has to be tipped to waste, and the disposal of this useless by-product is no small part of the iron-master's expense in running his works. It is to aid this that the apparatus before referred to has been devised by Mr. Hawdon. It consists mainly of two large pulleys, over which there runs an endless chain or a metal belt. The pulleys are mounted on horizontal shafts, parallel to each other, and placed in the same horizontal plane. The pulleys are driven by a steam-engine, and the chain is made to travel in this way. The latter is composed of solid bar links, joined by pins, and on it is mounted a continuous series of shallow pans or trays. At one end of the apparatus the stream of molten slag is directed into the pans, and, as the chain is moving continuously, each pan carries off a part of the material. The pans overhang, so that the metal will not spill on to the links. Between the two pulleys there is placed a large flat tank filled with water, and this is so arranged that the upper part of the endless travelling chain or belt dips into the water, the sag of the belt being sufficient for the purpose. There are guide rollers, but these are details which may be neglected in our explanation of principles. The slag flows into the trays just before they dip into the water, so that the molten metal is at once rapidly cooled. This has the effect of cracking the pieces so much that when they fall out of the trays—which they naturally do when the belt turns over the further pulley—into the barge or wagon, they are broken into convenient sized fragments. Mr. Hawdon claims that by this system a very large saving is effected in transporting slag, and a material of some commercial value is obtained, the pieces being of suitable size for railway ballast or concrete mixing. From what we hear of the apparatus it appears to do its work well so far.

The summer meeting of the Institution will be held this year at Portsmouth, on July 26 and three following days.

NO. 1163, VOL. 45]

### THE ELECTRICAL EXHIBITION.

ON Saturday evening last the Lord Mayor and the Lady Mayoress, accompanied by Mr. Sheriff Tyler, Mr. Sheriff Foster, Sir John Monckton, and many others, went to the Crystal Palace to inspect the Electrical Exhibition. After their walk round, which lasted about an hour and a half, the visitors were entertained at dinner in the large saloon off the south transept. Among the company were the Attorney-General, Sir Robert Rawlinson, Sir Frederick Abel, F.R.S., Prof. W. E. Ayrton, F.R.S., Major-General Webber, Prof. W. Crookes, F.R.S., Mr. Tesla, Mr. W. H. Preece, F.R.S., Sir James N. Douglass, F.R.S., Major-General Festing, F.R.S., Dr. Hopkinson, F.R.S., Mr. A. Siemens, Prof. Kennedy, Prof. Forbes, Prof. Robinson, Prof. Perry, Prof. Hughes, and Prof. Silvanus Thompson, F.R.S. In the unavoidable absence of the Chairman of the Crystal Palace Company, the Hon. D. J. Monson, the chair was taken by the Deputy-Chairman, Mr. G. T. Rait. After the usual loyal toasts, the Lord Mayor proposed "Success to the Exhibition." In doing so he said there was sufficient evidence to warrant him in predicting that the Exhibition would prove a very great success. He recollected how, ten years ago, the electric light occupied the minds of many people, and how at that time the light had what proved to be a very bad start. The light was then undertaken more as a speculation. This checked for a time electrical enterprise, though, in his opinion, it had done no great or permanent harm. He admitted, with some degree of shame, that in the City of London they had been very slow to move in the matter. It was possible that they might have hesitated to commit themselves to some appliance that might have been changed on the morrow. They were, however, in favour of the electric light, and the City had been handed over to the new lighting, which in a short time would be an accomplished fact.

Dr. Hopkinson, in giving "Electric Science and Industry," remarked that the reaction between these two had been very intimate.

Prof. Ayrton, President of the Institute of Electrical Engineers, who responded, said that it was impossible to imagine what progress would be made in electricity in another ten years. At present two conductors were necessary for every electric tramcar (laughter). They had anticipated his joke (renewed laughter). One conductor took the current, while the other took the current coin (laughter). It might be that in ten years street lamps would be no longer necessary, as vacuum tubes would be used for walking-sticks (laughter). The smoke plague and fog would no longer trouble us, for there would be no coal fires when we could bask in the rays of the electric field, repose in the genial warmth of an equipotential surface, and put our feet on a fender composed of horizontal lines of force (loud laughter). One suggestion he would make—that the electric light might be introduced into that room, for the warmth they had borne during the dinner had been surpassed only by the warmth of their reception by the Directors of the Crystal Palace (laughter).

Mr. R. E. Crompton, President of the Electrical Section of the London Chamber of Commerce, also responded.

Mr. E. Clark proposed "The Health of the Honorary Council and Committees of the Exhibition."

Sir F. Abel, in responding, declared that we were on the threshold of great advances in our knowledge of electricity and its applications.

Mr. W. H. Preece also responded, and congratulated the promoters of the Exhibition upon the fact that they had brought to bear upon the present position of electrical science a fierce and an impartial criticism.

Mr. Tesla acknowledged some compliments paid to him in the course of the evening.

Sir James Douglass gave "The Crystal Palace Company," and the Chairman responded.

### UNIVERSITY AND EDUCATIONAL INTELLIGENCE.

CAMBRIDGE.—Mr. J. J. Lister, of St. John's College, late Assistant Superintendent of the Museum of Zoology, has been appointed Demonstrator in Animal Morphology, in place of Mr. S. F. Harmer.

Mr. Alexander Scott, of Trinity College, has been appointed

Demonstrator to Prof. Dewar. The grace for establishing the office was opposed, but carried by 76 votes to 70.

Prof. Macalister has been appointed Chairman of the Examiners for the Natural Sciences Tripos in the present year.

The Fitzwilliam Museum Syndicate report that the catalogue of the Egyptian Collection, prepared by Dr. Budge, is now ready for printing, and will forthwith be published.

### SCIENTIFIC SERIALS.

THE *American Meteorological Journal* for December last contains six memorial articles upon the work of the late Prof. W. Ferrel, read at a meeting of the New England Meteorological Society in October last. Prof. W. M. Davis states that Ferrel's view of the general circulation of the atmosphere is now accepted in its essential features by most meteorologists; and were it not for the silence regarding it on the part of some of the British school, it would be regarded as universally acceptable. But in Great Britain it finds little recognition; unfortunately, Prof. Davis thinks, for the advance of the science in this country. The essential part of Ferrel's theory, first stated in 1859, is that an equatorial-polar convective circulation on a rotating earth must consist chiefly of oblique winds from a western quarter, with high velocities nearly at right angles to the gradients; and that the initial high pressure about the poles, due to low temperature, will be reversed to low pressure by the excessive centrifugal force of the whirling winds, thus leaving a belt of high pressure near the tropics. He draws a sharp contrast between the general circulation and the cyclonic circulation. Both are cyclonic, inasmuch as they whirl, but one has a cold centre, and the other a warm one.—H. Helm Clayton contributes an article on the verification of weather forecasts. Among the elements to be considered he includes (1) the kind of phenomenon, e.g. cloud, rain, &c.; (2) the time of occurrence; (3) the duration of the phenomenon; (4) the intensity; (5) the length of time in advance that the phenomenon is predicted. He also describes the methods of verification adopted in some countries.—Cold waves, by Dr. A. Woeikof. The object of the paper is to disprove Prof. Russell's theory that cold waves are not due chiefly to radiation from the ground, but to extreme cooling of the upper air. Dr. Woeikof shows from observations from various sources that the cold waves are certainly due to radiation, not necessarily at the place where the cold is felt, but at a distance—in the United States to the north-west, in Europe to the north-east.

### SOCIETIES AND ACADEMIES.

#### LONDON.

**Royal Society, January 21.**—"On the Mechanism of the Closure of the Larynx: a Preliminary Communication." By T. P. Anderson Stuart, M.D., Professor of Physiology, University of Sydney, Australia.

The epiglottis having been displaced from its time-honoured function of closing the larynx as a lid, the paper proceeds to show how after all the larynx is closed. Briefly, the closure is effected by, on the one hand, a folding up of the margins of the entrance and an obliteration of the channel of the vestibule from the entrance downwards to the level of the glottis, and, on the other hand, by the well-known movement upwards and forwards of the entire larynx against the base of the tongue—the lower part of the epiglottis intervening, but taking no active part in the process. The observations, &c., were made as follows: (1) on a man who has a large hole in the side of the neck, a result of an operation for epithelioma, through which deglutition, simple closure of the larynx, &c., can be observed proceeding in a manifestly perfectly normal manner; (2) on healthy persons examined by the laryngoscope by the author and by two professed laryngoscopists; (3) experiments on the different classes of animals; (4) the anatomy and comparative anatomy of the parts; (5) the clinical and *post-mortem* records of morbid conditions.

When simple closure is to be effected in man, the arytenoid cartilages, inclosed in the mucous membrane, (1) are rotated, so that the vocal processes (eventually) come into apposition; (2) glide forwards on the cricoid articular surface, so that the posterior broad part of their articular surface comes to rest on

the cricoid; (3) approach each other, so that their inner faces are, in part at least, in contact; (4) fold forwards at the crico-arytenoid joint, so that their tips come into contact with the lower part of the epiglottis. At the same time the aryepiglottic folds become tense, pulling inwards the lateral margins of the epiglottis, and so deepening its groove to receive the tips of the arytenoids and the Santorinian cartilages. Thus the entrance assumes the form of a squat T-shaped fissure, its transverse limb bounded in front by the epiglottis, behind by the aryepiglottic folds, and its vertical or antero-posterior or mesial—the more primitive—limb by the arytenoid cartilages. The head of the T is curved concave backwards and its stem is short. A slight movement of the entire larynx upwards and forwards takes place—not nearly so much as in deglutition. The epiglottis does not actively move, and in deglutition, for instance, the bolus is seen to glide over its laryngeal surface, its lingual surface being closely pressed against the dorsum of the tongue. But all animals are not alike, and too little account has been taken of differences in the anatomy of the parts, these carrying with them, as they do, differences in their physiology. The foregoing account applies only where, as in man, the arytenoids are long and narrow: where they are high and broad they move more bodily forwards, and where they are low and narrow, i.e. small, neither folding nor movement forwards would suffice to close the orifice, and there the lower part of the epiglottis is permanently bent backwards, so that the contact of the arytenoids with the front wall of the laryngeal cavity is effected with a minimum of movement of the arytenoids and the true vocal cords are, as it were, under cover of a sort of hood formed by the epiglottis. The exact behaviour of the distal portion of the epiglottis varies; it does the value of the movement upwards and forwards of the entire larynx, even in individuals of the same species. The arytenoids in their mucous membrane thus form a valve which, when it stands backwards, closes the food-channel and drafts the air forwards into the larynx, and when it lies forwards in deglutition closes the air channel and opens the food-channel. The external thyro-arytenoid muscles with the transverse arytenoid muscle, are the agents by which the before-mentioned four movements of the arytenoid cartilages are brought about. The aryepiglottic muscles tense the edge of the aryepiglottic fold, and cross to the base of the opposite arytenoid cartilage to avert the tendency they would otherwise have to pull asunder the arytenoids' tips. As worked out in the paper, it is seen that a very large number of details in the anatomy of the larynx receive an adequate explanation by this account of the closure of the larynx, e.g. the detailed anatomy of the muscles just mentioned, the sacculus, the structure of the false cord, the crico-arytenoid joint, its surfaces and ligaments, the anatomy of the larynx and its cavity in the different classes of animals, the epithelial lining the cavity, &c.

"Birds are extremely instructive in this connection. Here the vocal function is entirely removed from the larynx, so that the larynx has for its sole office the guarding of the entrance of the trachea. Inspection and experiment show the entrance to be closed by the arytenoid cartilages, or bones, and the thyro-arytenoid muscles. Since this is their function in Birds (and the same applies to Tortoises, Lizards, Reptiles, Frogs, &c.) is it not all the more likely to be at least a function in Mammals?"

The plane of the larynx at the level of the glottis corresponds to the larynx in its more primitive forms—linear when closed, lozenge-shaped when open, bounded exclusively by cartilage and muscle. In man the vocal function has been superadded: all that lies above the level of the glottis has been built on that level, and the vibrating property has been got at a physiologically cheaper rate through fibrous than through muscular tissue. For details we must refer to the paper in the Proceedings.

January 28.—"Note on some Specimens of Rock which have been exposed to High Temperatures." By Prof. T. G. Bonney, D.Sc., LL.D., F.R.S.

The first described were two specimens of the microgranite of Threlkeld (Keswick): the effect of heating (probably to about 200° F.) had been to melt down the felspathic and the micaceous constituents, cracking, but not materially affecting, the quartz. Next, in overburnt brick (composed mainly of disintegrated granite) from Les Talbots (Guernsey) similar effects: partial melting of larger fragments of felspar: in one case twin planes could be traced within the melted part. Thirdly, five specimens of melted basalt from Rowley Regis. Four of these

were glasses (one with spherulites), the fifth exhibited skeletal crystals of feldspar with a peculiar grouping, rarely and imperfectly seen in naturally-cooled basalts. With these were compared two specimens of magma-basalts, obtained by the author from the Kowley mass, which exhibited a very different structure. The author suggested that this difference might be due to the absence of water from the artificially melted rock, which might also account for the rarity of tachylites in nature.

February 4.—“On the Mechanical Stretching of Liquids: an Experimental Determination of the Volume-Extensibility of Ethyl Alcohol.” By A. M. Worthington, M.A. Communicated by Prof. Poynting, F.R.S.

After advertising to the three known methods of subjecting a liquid to tension, viz. (i.) the method of the inverted barometer, (ii.) the centrifugal method devised by Osborne-Reynolds, (iii.) the method of cooling discovered in 1850 by Berthelot, and pointing out that the first two afford means of measuring stress but not strain, while the third gives a measure of strain but not stress, the author proceeds to describe the manner in which he had used the method of Berthelot in combination with a new mode of determining the stress, and had succeeded in obtaining simultaneous measures of tensile stress and strain for ethyl alcohol up to a tension of more than 17 atmospheres, or 255 pounds per square inch.

The liquid, deprived of air by prolonged boiling, is sealed in a strong glass vessel, which it almost fills at a particular temperature, the residual space being occupied only by vapour. On raising the temperature, the liquid expands and fills the whole. On now lowering the temperature, the liquid is prevented from contracting by its adhesion to the walls of the vessels, and remains distended, still filling the whole and exerting an inward pull on the walls of the vessel. The tension exerted is measured by means of the change in capacity of the ellipsoidal bulb of a thermometer sealed into the vessel and called the “tonometer.” This bulb becomes slightly more spherical, and therefore more capacious, under the pull of the liquid, and the mercury in the tonometer-stem falls. The tension corresponding to the fall is previously determined from observation of the rise produced by an equal pressure applied over the same surface.

The liquid is caused at any desired instant to let go its hold and spring back to the unstretched volume corresponding to its temperature and to its saturated vapour pressure, by heating for a moment, by means of an electric current, a fine platinum wire passing transversely through the capillary tube that forms part of the vessel. The space left vacant in the tube represents the *apparent* extension uncorrected for the yielding of the glass vessel.

The measures obtained show that, within the limits of observational error, the stress and this apparent strain are proportional up to the highest tension reached (17 atmospheres); but, since the small yielding of the nearly rigid glass vessel must itself be proportional to the stress, it follows that the stress and absolute strain are proportional.

By subjecting the liquid to a pressure of twelve atmospheres in the same vessel, it was found that the apparent compressibility was the same as the apparent extensibility, whence it is deduced that between pressures of +12 and -17 atmospheres the absolute coefficient of elasticity is, within the limits of observational error, constant. Its actual value is best obtained by observations of compressibility.

The paper concludes with a description and explanation of a peculiar phenomenon of adhesion between two solids in contact when immersed in a liquid that is subjected to tension.

Physical Society, January 22.—Prof. O. J. Lodge, F.R.S., Vice-President, in the chair.—Prof. G. F. Fitzgerald, F.R.S., read a paper on the driving of electromagnetic vibrations by electromagnetic and electrostatic engines. The author pointed out that as the electromagnetic vibrations set up by Leyden jar or condenser discharges die out very rapidly, it was very desirable to obtain some means whereby the vibrations could be maintained continuously. Comparing such vibrations with those of sound, he said the jar discharges were analogous to the transient sound produced by suddenly taking a cork out of a bottle; what was now required was to obtain a continuous electromagnetic vibration analogous to the sound produced by blowing across the top of a bottle-neck. In other words, some form of electric whistle or organ-pipe was required. These considera-

tions led him to try whether electromagnetic vibrations could be maintained by using a discharging circuit part of which was divided into two branches, and placing between these branches a secondary circuit turned to respond to the primary discharge. This did not prove successful, on account of there being nothing analogous to the eddies produced near an organ-pipe slit. The analogy could, he thought, be made more complete by utilizing the magnetic force of the secondary to direct the primary current first into one of the two branches and then into the other. If spark gaps be put between two adjacent ends of the branches and the main wire, then the magnetic effect of the secondary current should cause the spark to take the two possible paths alternately. Electrically-driven tuning-forks and vibrating spirals were cases in which magnetic forces set up vibrations, but here the frequency depended on the properties of matter, and not on electrical resonance. The frequency of delicate reeds could, however, be controlled by resonance cavities with which they were connected, and he saw no reason why the same action could not be imitated electromagnetically, using an electric spark as the reed. Referring to the properties of iron in connection with electromagnetic vibrations, he pointed out that a prism of steel 1 millimetre long had a period of longitudinal vibration of about one-millionth of a second, and, as this was comparable with the rates of electromagnetic vibrations, the immense damping effect which iron had on such vibrations might be due to the setting up of sound vibrations in the material. Other methods of driving electromagnetic vibrations had suggested themselves in the shape of series dynamos or alternators. The polarity of a series dynamo driving a magnetic motor would, under certain circumstances, reverse periodically, and thus set up an oscillatory current in the circuit. Similar effects can be got from series dynamos charging cells or condensers. In an experiment made two weeks before, with Planté cells and a Gramme dynamo, reversals occurred every fifteen seconds. Greater frequencies might be expected with condensers. The latter case he had worked out theoretically. He had also tried experiments with Leyden jars and a dynamo, but got no result. This might have been expected, for the calculated frequency was such as would prevent the currents and the magnetism penetrating more than skin deep. Calling the quantity of electricity on the condenser  $Q$ , the differential equation for a dynamo of inductance  $L$ , and resistance  $r$ , and a condenser of capacity  $x$  is

$$L\dot{Q} + rQ + \frac{Q}{x} = \dot{I}Q,$$

or

$$L\ddot{Q} + (r - \dot{L})\dot{Q} + \frac{Q}{x} = 0.$$

If  $\dot{L}$  be = 0, the solution of the equation is

$$Q = Q_0 e^{-\frac{r}{L}t} \cos 2\pi \frac{t}{T},$$

and the rate of degradation of amplitude depends on the factor

$$e^{-\frac{r}{L}t}$$

If, however,  $L$  be greater than  $r$ , the exponent of  $e$  becomes +, and hence  $Q$  would go on increasing until limited by the saturation of the iron or the increased resistance of the conductors due to heating. A dynamo without iron, provided one could be made to run fast enough to send a current through itself, would be likely to give the desired effect. The author thought that by making such a dynamo large enough and its armature very long, it would be possible to get a frequency of about one million. Electrostatic machines seem, however, to be more promising driving agents. Like series dynamos, their polarity depends on the initial charge, and can be easily reversed. Hitherto such machines have been inefficient mainly on account of the sparking in them, but Maxwell had shown how this could be obviated. There was the same kind of difference between electromagnetic and electrostatic machines as between Hero's engine and the modern pressure engine. Like modern engines electrostatic machines worked by varying capacity, but the effect of this variation in electrostatic machines was only to vary the frequency and not the rate of degradation. From the fact that electrostatic multipliers could be driven by alternating currents, he thought they might be made to drive alternating currents. If magnetic currents could be obtained, then electrostatic engines would easily be produced. In conclusion, the author described a modified electrostatic multiplier which he



bell-ved offered a feasible solution of the problem. In this machine the collectors were supposed joined to the ends of the vibrating circuit, and would therefore become + and - alternately. Inductors and brushes were to be so arranged that an insulating cylinder turning between them should have many + and - charges distributed alternately round its periphery. By suitable adjustment these charges could be collected at the proper instants so as to keep up the vibration.—The chairman, Prof. Lodge, said the paper was very suggestive and full of interesting points. The subject of electromagnetic vibrations was attracting great attention in America in connection with the manufacture of light. Hertz's oscillations die out too soon to be satisfactory, for their duration rarely exceeds a thousandth part of the interval between consecutive discharges. The theory of dynamos charging condensers he considered extremely interesting, and thought the fact that the damping factor could be changed in sign must have tremendous consequences.—Dr. W. E. Sumner asked a question about a method of doubling frequency of alternation recently described by Mr. Trouton, in which the armature of one alternator excites the fields of a similar machine. Mr. Trouton had said that after once doubling the frequency it was not possible to go on doing so. He (Dr. Sumner) thought that by adding other machines the frequency could be still further increased, and gave a proof of the fact. In reply, Prof. Fitzgerald said that adding another machine increased the frequency by a given amount and did not double the preceding one. Hence to increase the frequency a thousand-fold, a thousand machines would be required, and on this account Mr. Trouton considered it impracticable. Prof. S. P. Thompson thought the paper very suggestive, and the acoustic analogies very interesting. Melde's apparatus was an instance of doubling or halving a frequency. On reading the title of the paper, he had expected hearing of a method of maintaining electromagnetic vibrations by giving occasional impulses in some such way as that in which a tuning-fork could be kept vibrating by allowing the hammer of a treble bell to knock against it. There was another method of intensifying electric oscillations which he had only seen mentioned in a patent specification by Sir W. Siemens, who suggested using a series dynamo with a telegraph cable to augment the signalling currents. On the subject of ironless dynamos he (Prof. Thompson) desired further information. Some years ago he had made calculations and found the speed at which they would require to run was so enormous as to be beyond the range of engineering possibility. Mr. C. V. Boys, referring to the author's suggestion of using an electric spark with alternate paths to maintain vibration, said that he had tried whether an oscillatory spark was displaced by a magnetic field, but the displacement, even when photographed by a revolving mirror, was barely appreciable. Prof. Perry asked for an explanation of the term "skin-deep magnetism." He was not previously aware that Sir W. Siemens had described a method of improving cable signalling by using a series dynamo. He himself had patented a somewhat similar arrangement. He had also made a dynamo without iron, but had not got it to work. In reply to Prof. Perry the author of the paper said that in electromagnetic vibrations the magnetic force alternates so rapidly that it could not penetrate far into the field magnet of a dynamo before it is reversed; hence the magnetism would only be skin-deep. Dr. Burton suggested that a commutator with many segments, something like that used by Mr. Gordon in his researches on specific inductive capacity, might possibly be employed for producing high frequencies.—A communication on supplementary colours, by Prof. S. P. Thompson, F.R.S., was postponed.

**Entomological Society, January 27.**—The fifty-ninth annual meeting, which had been adjourned from the 20th inst. on account of the death of H. R. H. the Duke of Clarence.—Mr. F. DuCane Godman, F.R.S., President, in the chair.—An abstract of the Treasurer's accounts, showing a good balance in the Society's favour, having been read by one of the Auditors, the Secretary, Mr. H. Goss, read the Report of the Council. It was then announced that the following gentlemen had been elected as Officers and Council for 1892:—President: Mr. Frederick DuCane Godman, F.R.S. Treasurer: Mr. Robert McLachlan, F.R.S. Secretaries: Mr. Herbert Goss and the Rev. Canon Fowler. Librarian: Mr. George C. Champion. And as other Members of the Council: Mr. C. G. Barrett, Mr. Herbert Druce, Captain Henry J. Elwes, Prof. Raphael Meldola, F.R.S., Mr. Edward B. Poulton, F.R.S., Dr. David

Sharp, F.R.S., Colonel Charles Swinhoe, and the Right Hon. Lord Walsingham, F.R.S. It was also announced that the President would appoint Captain Elwes, Dr. Sharp, and Lord Walsingham, Vice-Presidents for the session 1892-93.—The President then delivered an address. After alluding to the vast number of species of insects, and to the recent calculations of Dr. Sharp and Lord Walsingham as to the probable number of them as yet undescribed, he referred to the difficulty experienced in preparing a monograph of the fauna of even a comparatively small part of the world, e.g. Mexico and Central America, and certain small islands in the West Indian Archipelago, upon which he, with a large number of competent assistants, had been engaged for many years. The examination of the collections recently made in St. Vincent, alone, had obliged him to search the whole of Europe and North America for specialists; and similar collections from Grenada were still untouched in consequence of the number of workers being unequal to the demands upon their time. He observed that the extent of the subject of entomology was so vast that nothing but a systematic and continuous effort to amass collections, work them out, and preserve them, could place us in a position to proceed safely with the larger questions which followed the initial step of naming species: and it would only be by the steady effort of our Museum officials, not only to work at the subject themselves, but to enlist the aid of every available outside worker, that substantial progress could be made. The President concluded by referring to the losses by death during the year of several Fellows of the Society and other entomologists, special mention being made of M. André, the Duke of Devonshire, Mr. F. Grut, Mr. E. W. Janson, Prof. Felipe Poey, Sir William Macleay, Mr. H. Edwards, Mr. Robert Gillo, and Dr. J. M. J. Af Tengström.

**Geological Society, January 27.**—Dr. W. T. Blanford, F.R.S., Vice-President, in the chair.—The following communications were read:—On the hornblende-schists, gneisses, and other crystalline rocks of Sark, by the Rev. Edwin Hill and Prof. T. G. Bonney, F.R.S. The authors refer to Mr. Hill's paper, published in 1887, for a general description of the island. They were led to examine Sark again in the hope that its rocks might afford some clue to the genesis of the hornblende-schist of the Lizard. They describe the structure, macroscopic and microscopic, of the various foliated rocks. These are:—(a) The basement gneiss, a slightly foliated, somewhat granitoid rock, probably of igneous origin, but with some abnormal environment, and possibly intrusive into, instead of older than the rock which succeeds it. (b) The hornblende-schists, almost identical with those of the Lizard, but in one case yet more distinctly banded. (c) Banded gneisses, sometimes rather fine-grained, variably banded; quartzofelspathic layers alternating with those rich in biotite or occasionally hornblende. Some of these gneisses resemble the "granulitic group" of the Lizard; others recall certain of the less coarse, well-banded gneisses of Scotland, e.g. south of Aberdeen. Sometimes they are much "gnarled" by subsequent earth-movements, by which, however, as a rule, the crystalline rocks of the island do not appear to have been very seriously affected. (d) A very remarkable group of local occurrence which exhibits great variety. In some places large masses of a dark green hornblende-rock are broken up and traversed by a pale red vein-granite or aplite. The former rock is drawn out into irregular lenticles, elongated lumps, and finally streaks, and has been melted down locally into the aplite. This then becomes a well-banded biotite gneiss, which macroscopically and microscopically agrees with types which are common among the Archaean rocks. Sark therefore presents an example of the genesis of such a gneiss, and the authors are of opinion that probably all the above-named rocks are of igneous origin, but became solid ultimately under somewhat abnormal conditions, to which the peculiar structures (which distinguish them from ordinary igneous rocks) are due. They attribute the banding to the effect of fluxional movements, anterior to final consolidation, in a mass to some extent heterogeneous. This hypothesis they consider may be applied to all gneisses or schists which exhibit similar structures—that is, to a considerable number (but by no means all) of the Archaean rocks. The second part of the paper consists of notes on some of the dykes and obviously intrusive igneous rocks of the island. Among these are four (new) dykes of "mica-trap," one of which exhibits a very remarkable "pisolitic" structure. The variety of picrite described by Prof. Bonney in 1889 (from a boulder in Port du Moulin) has also been discovered *in situ*. The reading of this paper was followed

by a discussion, in which Major-General McMahon, Prof. Judd, Mr. Hudleston, Mr. Barrow, the Rev. Edwin Hill, and Prof. Bonney took part.—On the plutonic rocks of Garabal Hill and Meall Breac, by J. R. Dakyns and J. J. H. Teall, F.R.S. (Communicated by permission of the Director-General of the Geological Survey.) The plutonic rocks described occur in a complex forming a belt of high ground south-west of Inverarnan. They vary considerably in composition, and though gradual passages are sometimes found between more or less acid rocks, at other times the junction is sharp. The more acid are always found to cut through the less acid when the two rocks are found in juxtaposition, and fragments occurring in a rock are less acid than the rock itself. Though thus shown to be of different ages, they must evidently be referred to one geological period. The first rocks to be formed were peridotites; then followed diorite, tonalite, granite, and eruite in order of increasing acidity. The specific gravities, colours, and textures of the rocks are considered, and a detailed account of the constituent minerals given. The essential minerals are arranged in the following order, based on their general distribution in the different types of rock: olivine, pyroxene, hornblende, biotite, plagioclase, orthoclase and quartz, microcline. The following is the order in which the principal constituents commenced to form in the rocks: iron-ores, olivine, pyroxene, hornblende, biotite, plagioclase, orthoclase, microcline, and quartz. The chemical composition of the rocks is discussed, data being furnished by a series of analyses made by Mr. J. H. Player, and a diagrammatic representation of the molecular relations of the different bases and silica is given. The relations between mineralogical composition, chemical composition, and geological age are then considered; and the following conclusions are reached:—(1) That the various rocks have resulted from the differentiation of an originally homogeneous magma. (2) That the chronological sequence from peridotite to eruite is connected with the order of formation of minerals in igneous magmas. The paper was discussed by Dr. Hatch, Prof. Bonney, and Mr. Barrow.—North Italian Bryozoa; Part II. Cyclostomata, by Arthur Wm. Waters.

## PARIS.

Academy of Sciences, February 1.—M. D'Abbadie in the chair.—Note on a structure placed on the summit of Mont Blanc, by M. J. Janssen. It will be remembered that, after failing to reach the rock through the snow on the top of Mont Blanc, M. Janssen, last October, made some observations in a temporary hut for the purpose of testing whether it was displaced appreciably by the movement of the snow. The observations failed to indicate any movement. On January 2 the hut was visited by M. Dunod, and some observations made in it at M. Janssen's request show that no change of place has occurred during this interval of four months.—Observations of solar spots and facule made with the Brunner equatorial (0.16 metre aperture) of Lyon Observatory during the latter half of 1891, by M. Em. Marchand. (See Our Astronomical Column.)—Temperate regions; local conditions of persistency of atmospheric currents; derived currents; origin and translation of certain cyclonic movements, by M. Marcel Brillouin.—On an extension of Sturm's theorem, by M. E. Phragmén.—On Laplace and Lavoisier's apparatus for measuring the linear expansion of solids, by M. E. Grimaux. The author has come into the possession of some copper-plates drawn by Lavoisier in illustration of his method of determining the coefficient of linear expansion. Pulls have been obtained from these plates and presented to the Academy.—On the compressibility of saline solutions, by M. Henri Gilbault.—On electro-capillary phenomena, by M. Gouy.—On the optical determination of high temperatures, by M. H. Le Chatelier. Some experiments have been made with the idea of measuring high temperatures by determining the intensity of the radiations emitted by a pyrometer of platinum, or clay, or other material, when compared with the light of a standard lamp. The results obtained indicate that the method is a good one. The principal difficulties, of course, depend upon the fact that the radiations emitted by an incandescent body are affected by conditions other than temperature. M. Le Chatelier, however, seems to have satisfactorily overcome these difficulties.—On achromatism, by M. A. Broca.—Barium and strontium nitrides, by M. Maquenne. These nitrides are formed by the direct action of nitrogen at a red heat upon the metals obtained from amalgams formed by electrolysis. The analyses given prove their composition to be represented by  $N_2Ba_3$  and  $N_2Sr_3$  respectively. They yield ammonia on treatment with water, and may be viewed as

metallic ammonias. Barium nitride does not give ethyl bases when treated with alcohol. It reacts energetically at a red heat with carbon monoxide, producing barium cyanide and oxide. Strontium nitride similarly yields only a trace of strontium cyanide, the chief products being the oxide, carbonate, and carbon.—Carbon chlorobromides, by M. A. Besson. (See Notes.)—Action of metals on salts dissolved in organic liquids, by M. Raoul Varet. Certain metals, able to precipitate others from their salts dissolved in water, lose this property when certain organic liquids are used as solvents. This difference of action is due somewhat to the water and somewhat to the formation of molecular compounds formed by the union of the products present.—On monosodium mannite, by M. de Forcrand.—Transformation of sulphanic into sulphano-carbamic acid in the animal economy, by M. J. Ville.—Chemical study of the chlorophyll bodies of the pericarp of the grape, by M. A. Etard.—Researches on the adherence to the leaves of plants, and notably to the leaves of the potato, of copper compounds used to prevent their diseases, by M. Aimé Girard.—Development of the *organe vibratile* of Composite Ascidie, by M. A. Pizon.—On the locust (*Schistocerca peregrina*, Oliv.) and its changes of colour; rôle of the pigments in the phenomena of histolysis and histogenesis which accompany the metamorphosis, by M. Kunckel d'Herculeis.—On the commencement and extinction of cambial activity in trees, by M. Emile Mer.—Absolute surfaces and relative divisions of the earth occupied by the principal geological groups, by General Alexis de Tilló. The author states the relative surfaces, of each of the present continents, which existed in different geological periods.—Investigation of the nature of the waters and mud of Lake Anney, by M. L. Duparc.

## CONTENTS.

	PAGE
The Vacant Chair of Astronomy at Cambridge. . . . .	337
The Catalogue of Scientific Papers. By X. . . . .	338
The Aneroid in Hypsometry. By H. F. B. . . . .	339
Waller's Human Physiology. By Dr. E. H. Starling . . . . .	340
Our Book Shelf:—	
"Bulletin of the New York Mathematical Society" . . . . .	341
Harrison: "Guide to the Examinations in Chemistry" . . . . .	342
Bausch: "Manipulation of the Microscope" . . . . .	342
Barrett-Hamilton: "Harrow Birds" . . . . .	342
Letters to the Editor:—	
The Theory of Solutions.—J. W. Rodger . . . . .	342
Arrow Poison.—A. Coppen Jones . . . . .	343
The Implications of Science.—Dr. St. George Mivart, F.R.S. . . . .	343
The New Forest in Danger.—Herbert Goss . . . . .	343
On the New Star in Auriga . . . . .	344
Mr. Tesla's Lectures on Alternate Currents of High Potential and Frequency. By A. W. R.; G. . . . .	345
Wave-Motion Model. (Illustrated.) By F. Cheshire . . . . .	347
The Science Museum and Gallery of British Art at South Kensington . . . . .	348
Notes . . . . .	348
Our Astronomical Column:—	
Report of the U.S. Naval Observatory . . . . .	352
Observations of Nebule and Star-Clusters . . . . .	352
Solar Observations . . . . .	352
Measures of the Nebula near Merope . . . . .	352
Journeys in the Pamirs and Adjacent Countries. By Captain F. E. Younghusband . . . . .	353
The Institution of Mechanical Engineers . . . . .	355
The Electrical Exhibition . . . . .	356
University and Educational Intelligence . . . . .	356
Scientific Serials . . . . .	357
Societies and Academies . . . . .	357

THURSDAY, FEBRUARY 18, 1892.

## A COLLECTION OF MEMOIRS ON PHYSICS.

*Collection de Mémoires relatifs à la Physique.* Publiés par La Société Française de Physique, tome 1-5. (Paris, Gauthier-Villars.)

LA Société Française de Physique in the volumes before us have initiated a movement which cannot fail to be of the greatest service to students of physics. They are publishing collections of memoirs on one subject written by several authors, instead of following the more usual plan of collecting the papers of one author on a variety of subjects. There can, we think, be no question as to which plan is of most service to the student. The collected papers of one author must from the nature of the case be chiefly used as a work of reference, while the study of a collection of the most important memoirs ought to form an essential part of the reading of every advanced student of the subject. Now that the memoirs in which the foundations of the sciences of electrostatic or electromagnetism, and of investigations with the pendulum, are by the enterprise of the French Society so readily accessible, it is to be hoped that there will be a much greater development of the systematic study of the original memoirs than we are afraid prevails at present.

Science, as Maxwell said, is most easily assimilated when it is in the "nascent" condition, and, moreover, it is to be expected that when a long paper by a master of his subject has been condensed in a text-book to a twentieth of its original length, something of importance must be lost. In a text-book there is as a rule but little room for anything beyond the description of the method which ultimately proved successful, all reference to the difficulties met with, and the way they were overcome, has to be omitted, though these are precisely the points most calculated to induce the student to endeavour to make investigations for himself.

The volumes before us are also of especial interest to the student of science, as they contain papers such as those by Coulomb on electrostatics and magnetism, and by Ampère on electromagnetism, which raised the subject with which they dealt from chaos to order.

The first volume of these collected memoirs is edited by M. Potier, and differs somewhat in character from those which follow, inasmuch as it is entirely devoted to papers by Coulomb. It contains the classical memoirs in which he established by the aid of the torsion-balance the fundamental laws of electrostatics, and of the action between permanent magnets. It also contains a memoir on the loss of electricity by an insulated charged body, in which he comes to the conclusion that there is a leakage of electricity through the air; subsequent experiments have, however, shown that this is erroneous, and that there is no such loss when the air is free from dust and the charged body not under the action of ultra-violet light.

It is remarkable, considering the importance of Coulomb's contributions to electricity and magnetism, that his most important memoirs on these subjects were all published

within five years, 1785-1789, when he was between 49 and 53 years of age.

The editor gives as an appendix a very clear account of Poisson's and Sir W. Thomson's investigations of the problem of two electrified spheres. Poisson's papers on this subject are not very accessible, and we wish that they had been included in this volume, as his investigation of this problem is surely one of the most elegant pieces of analysis ever written. It is possible, however, that it was deemed to be too exclusively mathematical to be included in this collection of physical memoirs.

The second and third volumes, edited by M. Joubert, are devoted to electromagnetism. They include Ærsted's paper, published in France in 1820, announcing the discovery of the deflection of a magnet by a current, and the marvellous series of papers published almost weekly by Ampère, in which, in a few months after the publication of Ærsted's discovery, the "Newton of Electricity" established the action of a magnet on a current, and of one current on another, and of the identity of magnets and electric currents. In his earlier papers, those previous to 1822, Ampère seems to have been hampered by the erroneous idea that the force between two small elements of current at right angles to the line joining them was indefinitely small compared with that between the same element at the same distance when forming parts of the same straight line. Instead of being infinitely smaller, it is in reality, as he showed later, just twice as great. He soon, however, corrected this mistake, and in 1822 gave to the world a complete theory of the mechanical forces between currents in a memoir which is reprinted in these volumes, and which was described by Maxwell as "perfect in form and unassailable in accuracy."

In addition to the papers we have mentioned, there are many others dealing with points of the greatest interest: thus we find Ærsted, in his paper on the action of a current on a magnet, suggesting that light may be an electrical phenomenon, and Ampère writing in favour of this suggestion. In the second volume we have a paper by Faraday on electromagnetic solution; two papers by Davy, in one of which he describes a curious heaping up of a layer of mercury over the places where a strong current enters and leaves the mercury. This pretty effect is due to the mechanical force between the current in the leads and the current through the layer of mercury. This paper also contains Barlow's description of his electromagnetic wheel, and two papers, not hitherto published, by Fresnel, on Ampère's theory of magnets. Fresnel appears to have been the author of the suggestion that the currents by which Ampère explained the magnetic properties flowed round the molecules of the iron. In the third volume Weber's great paper on electrodynamic measurements appropriately completes the series of papers on electromagnetism, as the measurements made by the methods it develops afford a complete verification of the theory given in the preceding pages by Ampère.

The fourth and fifth volumes, edited by M. Wolf, contain memoirs on pendulum experiments. They commence with a well-written historical account of such experiments. Next we have a bibliography extending over 216 pages, and then follows a series of admirably selected papers of which the names speak for themselves. On

pendulum experiments pure and simple, we have memoirs by De la Condamine, Borda and Cassini, Prony, Kater, Bessel, Sabine, and Baily, and in addition to these we have Stokes's paper on the effects of fluid friction on the motion of pendulums.

We must, in conclusion, express our gratitude to La Société Française de Physique for the publication of these volumes, and to MM. Potier, Joubert, and Wolf, for the masterly way in which they have edited them. We hope that the volumes before us are but the first terms in an infinite series.

J. J. THOMSON.

### THE FORMATION OF BEACHES.

*Sul Regime delle Spiagge, e sulla Regolazione dei Porti.*

("On the Formation of Beaches, and the Rules for designing Harbour Works.") By Signor P. Cornaglia, late Inspector of the Royal Corps of Italian Civil Engineers. (Turin: R<sup>a</sup> Tipografia Paravia, 1891.)

THE laws that govern the movements of sand along the sea-shores, the formation and corrosion of beaches, the shifting of bars and sand-banks at the mouth of rivers, and the silting up of harbours, have not yet been clearly explained, as the problem is a complex one. These effects result from a combination of various causes, such as the action of sea-waves, of tidal currents, of the natural discharge of rivers, and of the dimensions and specific gravity of the materials that form the beaches and give them a special angle of rest.

To examine this problem, Signor Cornaglia takes it up in its most simple form. He tries to ascertain the laws that regulate the propagation and effects of sea-waves acting in a tideless sea, or nearly so, as is the Mediterranean. These researches are made both theoretically and practically, by the help of mathematical analysis and by verifying the results of theory by direct observations of waves in accumulating the materials that form the beaches. These form the subject of two memoirs, in which are discussed the vertical propagation of waves in liquids, and the origin and action of bottom-waves (*flutti di fondo*) in liquids in a state of undulation.

The results of these researches are thus expressed:—

(a) The undulatory movement of liquids generates near the bottom an oscillatory movement called *bottom-wave*, or under wave (*flutto di fondo*), which is alternately directed to or from the shore; (b) vertically under the crest of a superficial wave, the bottom-wave is directed toward the shore; under the hollow of a wave it is directed toward the sea; (c) the force of these bottom-waves increases with the force of the superficial waves, with the greater distance or "*fetch*" from which the waves arrive, and with the greater depth of the sea; (d) the energy of these bottom-waves may be great at great depths; (e) on a rising submarine slope the force of the bottom-waves directed toward the shore is greater than that of the reverse bottom-waves; (f) the bodies resting upon the bottom of the sea and exposed to these bottom-waves are struck in alternate directions; (g) the component of the weight of these bodies, parallel to the bottom slope, may counterbalance the effects of the direct bottom-waves, or, added to the effect of the return bottom-waves, these latter may prevail upon the direct

ones; (h) the line along which the action of each of the two opposite bottom-waves, combined with the component of the weight of the bodies, counterbalances that of the other, is called the *neutral line*; (i) all conditions being equal, this *neutral line* is situated at a greater depth the stronger the waves are, and the smaller the slope of the bottom and the size and specific weight of the bodies resting upon the bottom; (j) in the Mediterranean this *neutral line* is situated at depths varying from 8 to 10 metres, or 27 to 33 feet; (k) on the land side of the neutral line the materials forming the bottom of the sea are pushed by the bottom-waves toward the shore, on the sea side they are drawn toward the greater depths; (l) parallel to the shore the materials travel always in a contrary direction to that from which the waves come, and they travel alternately in one way or the other according to the direction of the waves. However, the ultimate direction in which these materials move is that corresponding to the prevailing waves, which is also, more or less, that of the prevailing winds.

In a third memoir the author discusses the formation or corrosion of beaches in a tideless sea, and explains a long series of observations and experiments made principally by himself along the shores of the Riviera, with a view of ascertaining the position of the neutral line.

In a fourth memoir are examined the conditions of the estuary of a river opening into a tideless sea, and the effects due solely to the waves having been previously ascertained, the effects due to the outgoing water of the river are described. Then the author passes on to examine the case of a river opening into a sea subject to the influence of tide and tidal currents; and by separating the effects of the waves and of the outgoing water of the river proper, he tries to explain the effects due exclusively to the action of tides. From this he gives some hints about the probable position of the neutral line resulting from all these different causes, and by comparing the conditions of the Mersey with those of the Thames and other tidal rivers, the author concludes that in the former case the outlet of the river is on the land side of the neutral line, and thus the materials brought down by the river or washed away from the coast are pushed into the estuary, while in the case of the Thames its outlet is on the sea side of the corresponding neutral line, and the materials are drawn into deeper water. In the same way he explains why some harbours in the Mediterranean having their entrance in depths of water superior to 10 metres, and thus outside the neutral line, have kept good for centuries, while other harbours with their entrance inside the neutral line have gradually silted up.

Having thus explained his views on the formation of beaches, Signor Cornaglia makes use of them in laying down in several memoirs the principal rules for designing such maritime works as may be necessary to maintain or improve the navigable channel in the estuary of a river, or to protect the entrance of a harbour, or to prevent the sea from encroaching upon a beach. There are descriptions of works carried out in several Italian harbours during this century, and the results, good or bad, according to the way these works were designed.

A drawback to this book is that it is written in the form of separate memoirs, so that there are many repetitions and some unnecessary details, which rather diminish than

add to the clearness of the work. Taken as a whole, however, the book will be read with interest and advantage both by the maritime engineer and by the geologist.

### EGYPTIAN HISTORY.

*Egypt under the Pharaohs.* By H. Brugsch-Bey. A New Edition, condensed and thoroughly revised by M. Brodrick. (London: John Murray, 1891.)

THE science of Egyptology is scarcely seventy-five years old, and published formulated statements of the history of Egypt derived from the comparatively newly-acquired decipherment of hieroglyphics are not yet thirty years old; books on Egyptian history are now so common that the general reader has yet difficulty in deciding which of those available is best for him to read or study. Dr. Birch's "Egypt from the Earliest Times to B.C. 300" printed, we believe, in 1875, is without doubt, the best of all the small histories of Egypt which have ever been written: the facts are to be depended upon, few alterations are necessary, difficulties are not slurred over, and the whole subject is there treated with the breadth of view and learning only to be found in such a scholar. More concise, but written in the same admirable style, is the "Aperçu" of Mariette, which aimed at presenting in a small compass the principal facts of Egyptian history to the visitors to the Exhibition in Paris in 1867; for the general history of Egypt and the relations of her people with foreign nations in the various epochs of her national life, the reader would naturally consult Maspero's "Histoire Ancienne des Peuples de l'Orient," and Lenormant's "Histoire Ancienne de l'Orient." The best examples of scientific histories of Egypt are those of Dümichen and Wiedemann. In the "Aegyptische Geschichte" of the latter scholar, published at Gotha in 1884, the author not only sets before the general reader or student the statements of certain facts, but gives in foot-notes the authorities for the statements, so that his work may easily be controlled.

This was an important step in advance, and has done more to convince people generally that the decipherment of the Egyptian inscriptions has been productive of important results than can be directly estimated. Long, however, before any of the above-mentioned works was written, or probably planned, Dr. Brugsch, the greatest of all living Egyptologists, so far back as 1859, published the first part of a history of Egypt which was to begin with the earliest monument, and to end with our own days; this part was entitled "L'Égypte sous les Rois Indigènes," and was published with 19 plates in quarto, but the two other parts, which were announced to contain the history of Egypt under the Greeks and Romans, and under the Arabs, seem never to have appeared. In 1876 Dr. Brugsch published his "Geschichte Aegyptens unter den Pharaonen," in two volumes, with maps and tables; and in this work he dealt with the history of Egypt as comprised in the thirty dynasties, beginning with the first historical king, Menes, and ending with Nectanebus. The narrative was written in fine German, and nearly every important event in the history of Egypt, as then known, he described by translating the hieroglyphic

inscription which referred to it. These translations read easily, and, on the whole, represented very well the sense of the Egyptian inscriptions in the words of a modern language. In 1877 Mr. John Murray published an English translation of this work entitled "A History of Egypt under the Pharaohs," with Maps, by H. Brugsch; the translation was the joint work of Danby Seymour and Philip Smith, and although it was on the whole good, it was only too evident that on certain points of Egyptology the translators had no special knowledge, while the beauty of Dr. Brugsch's style was, of course, lost in the process of translation. In 1881, Mr. Murray issued a second edition of the work, which, in addition to a new preface by Dr. Brugsch, contained a number of notes by Philip Smith, which were helpful to the reader, and several alterations and corrections by the author himself; the thirty-two pages of additions and notes were also most useful. During the past ten years great strides have been made in the science of Egyptology, notwithstanding the loss, by death, of Birch and Lepsius, the fathers of Egyptology; and general investigations into the history and language of Egypt have resulted in the discovery of a host of new facts, many of which have an important bearing upon the received ideas on these subjects. That a new edition of Brugsch's "Aegypten," or of its English translation is called for, is not to be wondered at, and no one has shown himself more sensible of this need than Mr. Murray himself. We venture to submit, however, that any attempt to "condense" or "thoroughly revise" the work by anyone except Dr. Brugsch or some competent hand was a mistake. The "condensed" edition of "Egypt under the Pharaohs" now before us contains 450 pages of text 8vo., and three maps; all Philip Smith's notes, which, as we before said, were useful to the general reader for whom this book is intended, are deleted, Brugsch's article on the Exodus, the additions and notes, the transliteration and translation of the stele of Usersten III. have been omitted, and the originally full index has been cut down. Each page contains five lines more than the second English edition, hence we necessarily expect the "condensed" edition by Miss Brodrick to be a smaller book; but seeing also that by cutting out clauses and important adjectives, &c., &c., she has succeeded in putting 49 pages of the second English edition into 18 of the condensed edition, we do not understand the statement made in the second paragraph of her preface that nothing has been omitted except the Essay on the Exodus and the transliteration, &c., of the Tablet of Usersten.

We have no doubt that Macaulay's "History of England" could be condensed to one-fifth of its present size by cutting out all that is explanatory of facts; but what should we gain by this mutilation? Miss Brodrick's condensation has been so vigorous that Brugsch's explanation of the word "Hyksos," which occupies fifty-seven lines in the second English edition, occupies only eight in hers; and where Brugsch gives two references to one event described in the Bible, Miss Brodrick omits the one which refers to the fuller narrative (p. 375, note 4). "The much-vexed question of the nationality of the Bubasties has, so far as possible, been accommodated to Brugsch-Bey's present views" by omitting whole paragraphs which occur in the second English edition.

In the condensed edition the cartouches of Egyptian kings which stood at the head of the chapters in the second English edition have been placed at the beginning of the book, and Miss Brodrick has added five pages of matter on the Dér el-Bahari mummies.

We have long hoped that Dr. Brugsch would issue a new edition of his "Aegypten unter den Pharaonen," revising his facts in some places, and correcting his statements in others, and also adding the new facts relating to the periods between the VII.-Xth and XIII.-XVIIth Dynasties, which have recently come to light; failing this, which is much to be desired, we hoped that one of his pupils would do the work under his guidance. That, however, the English translation made by Seymour and Smith, mutilated and robbed of its notes, and of the additions of the author, should be issued as a popular text-book of Egyptian history under Brugsch's name is a fact which we deplore.

#### OUR BOOK SHELF.

*The Story of the Hills: a Popular Account of Mountains, and how they were made.* By the Rev. H. N. Hutchinson, B.A., F.G.S. (London: Seeley and Co., 1892.)

THIS is a pleasant, chatty book, all the more welcome because wholly unpretentious; not too deep for "human nature's daily food" when roaming among the hills of which it treats. It will be read with pleasure and profit by the tourist, who likes to know just enough about the sundry points of interest connected with the scene of his wanderings to make the enjoyment of his outing intelligent, but who is not haunted by a feverish anxiety to be for ever, in season and out of season, improving his mind. Many who would shrink from a formal scientific treatise with horror or disgust will find themselves able to enjoy this book, and through its channel scraps of useful knowledge may insinuate themselves into their minds which would never have found their way there by any other road.

Part I. is multifarious, and touches on a vast variety of matters more or less connected with mountains, and principally of human interest—mountain races, mountain legends, the uses of mountains to mankind, mountain storms, avalanches, and the plants and animals of mountains. Scientific explanations of facts and phenomena are interspersed: the severe critic may detect a little vagueness and looseness here and there in these, but no very serious lapse. Well-chosen quotations from Ruskin and other authors give brilliancy to the narrative. There are landscape views reproduced from photographs, which have all the excellences and the artistic failings of this class of illustration.

Part II. is mainly taken up with a geological history of mountains. Here all the main geological truths that bear on the subject are expounded clearly, and with great fullness of detail. In fact, an epitome is given of a large number of the leading doctrines of geology, which will suffice for the needs of many a general reader. A separate chapter is devoted to volcanic mountains and volcanic activity. We may note that the three stages in the life of a volcano mentioned on p. 266 are not such as are usually defined by geologists. A. H. G.

*The Optics of Photography and Photographic Lenses.*

By J. Traill Taylor. (London: Whittaker and Co., 1892.)

ALTHOUGH photography is so widely practised at the present day, it is surprising how little is known by

amateurs about the principles that underlie the construction of photographic lenses.

The present work will serve as an excellent guide to those who wish to gain this information, and should be found to be of great practical use. The author has dealt with the subject in a very popular manner, and although the mathematics is reduced to a minimum, he has made his meaning very clear throughout.

In the first few chapters the nature and properties of light are discussed, together with explanations of photographic definition, single and achromatic lenses, cause of the inverted image, spherical aberration, nature and function of diaphragms, nature and cure of distortion, optical centres of single and combination lenses, &c. Chapters xi. to xv. treat solely of lenses, including accounts of the non-distorting, wide-angle, portrait, landscape, copying, and universal lenses. As there are thirty-nine chapters in all, we may mention that of those remaining there are many on subjects which may be of special interest to individual readers. Thus we have a chapter dealing with photo-telescopic lenses, a short one on the grinding of lenses, and another on enlarging and projecting in relation to lantern optics.

It will be seen that the author has dealt with a wide range of subjects in which the lens makes its appearance, and the reader will find that the explanations are lucid, while the illustrations bring out the points which they are intended to show with equal clearness. W.

*The Evolution of Life; or, Causes of Change in Animal Forms.* A Study in Biology. By Hubbard Winslow Mitchell, M.D. (New York and London: G. P. Putnam's Sons, 1891.)

DR. MITCHELL says in the preface to this book that he has accomplished in it "all that can be reasonably expected from a medical man deeply immersed in the duties of his profession." What most people expect from medical men in this position is that they will not write books on vast and complicated subjects, for the proper treatment of which an author must have not only exceptional ability but ample opportunities for philosophic study. So far as we have examined the work, it has neither freshness of thought nor charm of style. Dr. Mitchell mentions that he has travelled in many different parts of the world. If he was determined to write a book, he would have been better employed in recording his reminiscences as a traveller than in tediously discussing questions which have occupied so many of the foremost intellects of the present age.

#### LETTERS TO THE EDITOR.

[The Editor does not hold himself responsible for opinions expressed by his correspondents. Neither can he undertake to return, or to correspond with the writers of, rejected manuscripts intended for this or any other part of NATURE. No notice is taken of anonymous communications.]

#### A Magnetic Disturbance.

OUR attention having been directed for some days past towards a spot of unusual size upon the sun's disk, we were not by any means surprised to observe, as doubtless many of your readers elsewhere also did, an aurora of great beauty on Saturday night last; nor was our anticipation of seeing a magnetic disturbance portrayed upon the magnetograph records disappointed in the morning, for when the sheets were changed and the photographs developed, we saw that perturbations more violent than any which had been recorded at Kew for the past ten years had been in progress since about 5.45 a.m. of February 13.

The magnets were very quiet on Friday, but early on Saturday morning they became disturbed. The easterly declination

slightly increased until about 5.40 p.m., whilst both horizontal and vertical forces similarly increased in intensity, more especially between 4 and 6 p.m. They further diminished in force after 10 p.m., and their changes became very rapid from 12 midnight to 2 a.m., whilst at the same time the declination proceeded to its extreme westerly position. Subsequently, the fluctuations in magnetism became much reduced in extent, and the whole disturbance gradually diminished and died out about 4 p.m. of Sunday.

The Kew magnetometers were not able to record the complete extent of the vibrations to which free needles were subjected, nor could the entire change of force be secured in the field of the instrument. The limits, however, clearly recorded were 2° of declination from '1760 to '1830 of horizontal force, and from '4350 to '4420 units of vertical force expressed in C.G.S. measure in absolute force.

G. M. WHIFFLE,  
Superintendent.

Kew Observatory, Richmond, Surrey, February 16.

### The New Star in Auriga.

PROF. COPELAND has suggested to me that as I am the writer of the anonymous postcard mentioned by you a fortnight ago (p. 325), I should tell your readers what I know about the Nova.

It was visible as a star of the fifth magnitude certainly for two or three days, very probably even for a week, before Prof. Copeland received my postcard. I am almost certain that at two o'clock on the morning of Sunday, the 24th ult., I saw a fifth magnitude star making a very large obtuse angle with  $\beta$  Tauri and  $\chi$  Aurigæ, and I am positive that I saw it at least twice subsequently during that week. Unfortunately, I mistook it on each occasion for  $\beta$  Aurigæ, merely remarking to myself that  $\beta$  was a much brighter star than I used to think it. It was only on the morning of Sunday, the 31st ult., that I satisfied myself that it was a strange body. On each occasion of my seeing it, it was slightly brighter than  $\chi$ . How long before the 24th ult. it was visible to the naked eye I cannot tell, as it was many months since I had looked minutely at that region of the heavens.

You might also allow me to state for the benefit of your readers that my case is one that can afford encouragement to even the humblest of amateurs. My knowledge of the technicalities of astronomy is, unfortunately, of the meagrest description; and all the means at my disposal on the morning of the 31st ult., when I made sure that a strange body was present in the sky, were Klein's "Star Atlas," and a small pocket telescope which magnifies ten times.

THOMAS D. ANDERSON.

21 East Claremont Street, Edinburgh, February 13.

### Nacreous Clouds.

IN the morning of the 30th ult. there was a magnificent display of the nacreous (or iridescent, as they were first called) clouds, which formed such a striking feature of the sunset and sunrise sky for some days in succession in December 1884 and 1885 (vol. xxxi. pp. 148, 192, 316, 360, &c.). They were not exactly the same in appearance, but I should say they were of the same nature. I had not seen them in the interval of six years, and have only noticed them lately on the one day mentioned. They were confined to the southern part of the sky. As the sun rose higher their colours were less visible, and the clouds disappeared about noon; though in the afternoon some reappeared, but never became very striking. At 5h. 44m. G.M.T. there was only one group, which was too far from the sun to show any nacreous colours; its centre was about at hour-angle 1h. 2m. west, and declination  $23\frac{1}{2}^{\circ}$  south. Although conspicuous they were no longer very bright, and I should say the sun was evidently not shining on them, for they were the same bluish-green colour as the western sky, and I apprehend were illuminated by the sky.

T. W. BACKHOUSE.

Sunderland, February 9.

### The Cause of an Ice Age.

IN his very kindly review Prof. Darwin thinks I might have stated my argument with more completeness if I had preserved its generality by the use of a symbol instead of taking a special case.

No doubt in many ways the treatment he suggests would have been better. It would, for instance, have enabled me to prove the case *a fortiori*. Perhaps, however, the reasons given in the chapter explaining "why the book has been written" may show that for the object I had in view the method actually used was appropriate.

I am also much obliged to the same friend for pointing out that the astronomical theorem proved in the appendix had been given by Wiener, "Über die Stärke der Bestrahlung" (*Zeitschrift für Oesterreichischen Gesellschaft für Meteorologie*, vol. xiv., 1879, p. 129).

ROBERT S. BALL.

Observatory, Co. Dublin, February 9.

### Ice Crystals.

WITH reference to the letter on the subject of ice crystals which appeared in NATURE of the 4th inst. (p. 319), it is perhaps worth mentioning that a paper on the subject, entitled "Eine Eiskrystallgrothe," by C. A. Hering, appeared in Groth's *Zeitschrift für Kristallographie und Mineralogie*, Band xiv. (1888), pp. 250-253, and Plate vi.

The crystals occurred in an old mine on the Waschgang near Döllach in Carinthia. Large fans, as much as 300 mm. long  $\times$  200 mm. broad, of ice-crystals grow out horizontally from the vertical walls. The stalk, consisting of a series of hexagonal prisms, hollow, like thermometer-tubes, was in the middle 25 mm. thick and thickened towards the point of attachment to the rock. The fan surface was a large hexagonal plate with strong prismatic ribs running from the centre to the angles. The interspaces between the ribs were filled by prisms arranged with the greatest regularity. Upon the ribs of the fan either single crystals or funnel-shaped structures with step-like sides consisting of prisms were borne. The individual crystals were almost all thick tabular forms, with prism, basal pinacoid, and rhombohedral faces.

BERNARD HOBSON.

Owens College, Manchester, February 8.

### A Rare British Earthworm.

IN the summer of 1890, during my researches into the Vermes of Cumberland, I discovered a species of earthworm which proved to be new to Britain (*Lumbricus Eiseni*, Levinson). As I have recently had the good fortune to receive specimens of the same worm from another part of the country, it seems desirable to place the same on record. A correspondent writes from Gloucestershire as follows:—

"Last Saturday (January 30, 1892), I walked up to one of my favourite woods here on the Cotswolds, about 700 feet above the sea—a damp old beech wood, the Frith Wood of Withering's "Arrangement," seventh edition, 1830—and seeing a stump of some 10 inches diameter with a growth of the black 'Candle Snuff Fungus' on it, I examined the rotten wood, which gave way to the pokes of my stick. Among this rotten wood I saw some earthworms, two or three of which I inclose, hoping they may prove an addition to our worm fauna."

I have placed on record all the known earthworms of Gloucestershire in *The Field Club* for 1891, to which this may now be added. The worms were small, but in good form for identification, and prove to be specimens of Eisen's worm. I have, unfortunately, been unable hitherto to consult Levinson's original description; nor have I been able to obtain Rosa's memoir published in the *Boll. Mus. Zool.*, Torino, 1889 (vol. iv., No. 71). I am therefore obliged to content myself with a description of the specimens in my possession.

*Lumbricus Eiseni*, Lev., as found in Britain, is a small species of earthworm, measuring about 1½ inches in length when adult. It has the usual colour of the allied species—the purple and red worms—being of a ruddy hue, with iridescence. The clitellum or girdle, which occupies segments (24) 25 to 31, is a reddish-brown, being lighter in colour than the anterior portion of the worm's body on the dorsal surface. Ventrally the worm is, as usual, of a lighter shade. No *tubercula pubertatis* have been seen under the girdle, but the first dorsal pore in every specimen examined is clearly detected behind the 5th segment. This may be indicated by the fractional sign  $\frac{5}{2}$ ; and as the most recent researches tend to demonstrate the constancy of this character for each species of earthworm, it is important to note the same. The lip or prostomium has the complete mortise and

tenon arrangement which distinguishes *Lumbricus* from *Allolobophora*.

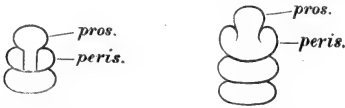

The male pore is situated normally on segment 15, but as the papillæ which carry the pores are large, they extend over the adjoining segments on either side. Earthworms vary greatly in this respect. Rosa says that spermathecae are absent in this species, a peculiarity which has been noted in worms belonging to several other genera. I have not sufficient material to enable me to confirm or dispute this statement at present. I have counted the segments of three specimens, and found them to be in each instance 106. As the year advances I hope to be able to obtain mature adults for dissection, when it will be possible to give a detailed account of the internal anatomy. Meanwhile the external characters are amply sufficient for distinguishing the worm if the girdle is properly developed, as its nearest British ally (*Lumbricus purpureus*, Eisen) has the clitellum on segments 28 to 33.

HILDERIC FRIEND.

Idle, Bradford.

### The Implications of Science.

WILL you allow me to say something in answer to Mr. Dixon's letter on this subject in NATURE of January 21 (p. 272)?

(1) I admit that there is a verbal or symbolic "convention" if two (or more) persons agree to understand any given words or symbols in a way arbitrarily chosen by themselves. But the scope of such convention is exceedingly limited: if people wish to be understood, or even to understand themselves, they must use the same words as others use, and use them in the same sense (except in an infinitesimal proportion of case-). If it is said that the common application and use of current words is a mere convention, the word *convention* is taken in an extremely strained and metaphorical sense, since nothing like an explicit agreement has ever been made. The "convention" as to the use of language is as fictitious as the *social contract* of Locke and Rousseau. But in the one case, as in the other, there is a solid basis of facts, to suit which the hypothesis has been produced. Language has been moulded by thought and feeling, which, in their turn, have been impressed by facts; and it is facts and relations of facts that language seeks to express. As Mill says (in the first chapter of his "Logic") names are a clue to things, and bring before us "all the distinctions which have been recognized not by a single inquirer but by all inquirers taken together." No one, I imagine, would say that a particular case of the impossibility of affirming and denying a given statement, depends "solely on the law of contradiction"; but in the case of any particular assertion, the impossibility, in that case, is seen, and to a mind that has reached the generalizing stage, the universal is discernible in the particular. As regards the question of "real propositions," I will not occupy space with quotations, but will only refer to Mr. Dixon's letter of December 10, in which the passages occur which led me to think that he regarded assertions (or denials) of the existence of particular objects as the only "real" propositions.

(2) As regards induction, I agree with Mr. Dixon that the starting point in induction is hypothesis or discovery. But with reference to the rest of the procedure, and its relation to so-called "formal" logic, I differ from him. For I think that an inductive generalization may be set out syllogistically; e.g.,

What has once produced X will always produce X;  
A has once produced X;  
∴ A will always produce X (= all A is X).

If space allowed, I should like to consider the justification for the major premiss, and also to say something about the grounds on which the minor (which indicates the hypothesis or discovery) asserts causation [or concomitance] in a given instance.

(3) Mr. Dixon says: "We do not, in mathematics, conclude a universal proposition from a single concrete instance." But it appears to me that, as far as my own experience goes, in every concrete mathematical proposition which I understand this is exactly what happens; and I do not see how, on Mr. Dixon's

view, mathematical formulæ could ever have been constructed. "A mathematical formula," Mr. Dixon remarks, "does not imply the existence of any instance whatever of its application, any more than a definition implies the reality of the thing defined." But if a definition is always of a thing, what more is wanted? The definition is admitted to be of something; and what is something must, I suppose, exist somehow.

(4) I still think that in the passage in Mr. Dixon's letter which I referred to under (4) he is not consistent. For if, as he asserts, the definition of four as  $= 1 + 1 + 1$ , makes it false to say that *Twice two are four*, this is surely because the facts referred to by four are no longer what they were when the statement in question was true. If definitions were purely arbitrary, as Mr. Dixon holds, what would prevent my saying that *Four* ( $1 + 1 + 1$ ) means twice two ( $1 + 1$ ) + ( $1 + 1$ )? It is surely only the reference to things which makes it absurd—and (and, however four (4) may be defined, how is one (1) to be understood, except by reference to things?).

That words and symbols used intelligently do, and must, refer to something beyond themselves, seems to me indisputable. If they did not, no assertion of the form *S is P* could ever be made, for the symbol S is certainly not the symbol P. And for any statement, of the form *S is P*, to be possible and significant, it is further necessary that S and P should have identical application, but diverse signification. If application and signification were the same, we should get *S is S* and *P is P*; if application were not the same, we must say, *S is not P*. Hence, no term can ever be taken in mere denotation (or application), nor in mere connotation (signification); but both momenta of each term have to be taken into account in every assertion. If (to take a case given by Mr. Dixon in his "Essay on Reasoning," p. 8) we "define" metal as "the list of denotation, iron, copper, tin, zinc, lead, gold, and silver," then iron, &c., can only be pointed out by taking some specimen of iron, and saying, *This and all other things which are LIKE it in certain respects*. An absolutely arbitrary denotation can be given only if the whole of the objects denoted are severally pointed out; and even then, unless they are labelled, they can only be remembered and identified by means of their characteristics; if labelled, by that characteristic.

Mr. Dixon objects to my attributing to him the view that "mathematical truths in as far as 'real' are obtained by induction, and are therefore not necessary." But in his letter of December 10 he says:—"For example, the assertion 'Two straight lines cannot inclose a space' is certainly not a 'necessary truth.' Either its terms are defined by connotation, so that its truth depends solely on those definitions, or else its terms are defined by denotation, as representing real things in space; and the truth of the assertion can only be proved by induction from actual experience with those things." In the first case, the truth is arbitrary, not necessary; and in the second case it might conceivably be false, as was shown by Helmholtz." It was this passage which led me to the opinion which I expressed.

Cambridge, January 31.

E. E. C. JONES.

### Vacuum Tubes and Electric Oscillations.

I HAVE not had the advantage of hearing the lecture of Mr. Nikola Tesla nor of seeing his experiments, but it does not seem out of place to recall the attention of your readers to an article by Dr. Dragoumis in your issue for April 4, 1889, in vol. xxxix, p. 548.

OLIVER J. LODGE.

### THE NEW STAR IN AURIGA.

SINCE our last article was written the weather has continued very bad for astronomical observations. The only new results obtained which have reached us consist of a paper read by Mr. Norman Lockyer at the Royal Society on Thursday last, and an important telegram from Prof. Pickering, which appeared in Wednesday's *Standard*.

We will take these in order. Mr. Lockyer's communication to the Royal Society was dated February 8; it stated that two more photographs, containing many more lines than the former ones, were taken on Sunday night, February 7, and it went on to make the important announcement that "The bright lines K, H,  $\lambda$ , and G are



accompanied by dark lines on their more refrangible sides."

This was substantially the substance of the telegram which appeared in the *Standard* on the following Wednesday (February 10), with the additional remark that the Harvard astronomers thought it possible that the phenomena presented by the new star had been caused by the collision of two celestial bodies.

On the next day the detailed observations made on Sunday night at Kensington, together with the approximate wave-lengths of the lines measured on the photographs, were sent on by Mr. Lockyer to the Royal Society. From these we learn that the Nova on Sunday appeared to be slightly brighter than on February 3.

With the 10-inch refractor and Maclean spectroscope, C was seen to be very brilliant, and there were four very conspicuous lines in the green. Several fainter lines were also seen, and a dark line was suspected in the orange. Mr. Lockyer noticed that some of the lines, especially the bright one near F, on the less refrangible side, appeared to change rapidly in relative brightness, and this was confirmed by Mr. Fowler.

Observations of the spectrum were made by Mr. Fowler with the 3-foot reflector and the Hilger 3-prism spectroscope. These call for no special remark.

Twenty bright lines have been measured on the photographs, and their wave-lengths are given in the accompanying table:—

Lines in the spectrum of Nova Aurigæ.				Bright-line stars.	Orion stars (dark lines).	Nebula in Orion (bright lines).
1st Photo. Date, February 3. A obtained by means of a curve.	2nd Photo. Date, February 3. A obtained by means of a curve.	3rd Photo. Date, February 7. A obtained by means of a curve.	3rd Photo. Date, February 7. A obtained by means of a direct comparison with lines in a Cygnus.			
K 3933	3933	3933	3933	—	3933	3933
H 3968	3968	3968	3968	3970	3968	3968
4101	4101	4101	4101	4101	4101	4101
4128	4130	4127	4128	—	4130	4130
4172	4172	4172	4172	—	4172	—
4226	4227	4228	4226	4200	—	4200
4268	4268	—	4264	—	4268	4268
—	—	4294	4291	—	—	—
4312	4310	4310	4310	—	—	—
G 4340	4340	4340	4340	4340	4340	4340
—	—	—	4383	—	—	4383
—	—	—	4412	—	4415	4410
—	—	—	4434	—	—	—
—	—	—	4469	4472	4472	4472
4516	4516	4522	4518	4510	—	—
4552	4552	4554	4555	4550	—	—
4587	4587	4584	4587	—	—	—
4618	4618	4625	4625	4620	—	—
—	—	4860	4860 F	4860	4860	4860

The table also shows probable coincidences with the lines in the spectra of the Wolf-Rayet stars as photographed by Prof. Pickering, dark lines in Orion stars photographed at Kensington, and bright lines in the Orion nebula photographed at Mr. Lockyer's observatory at Westgate.

In addition to the lines recorded in the table, the photographs in the spectrum of the Nova show several lines more refrangible than K. They probably include some of the ultra-violet hydrogen lines.

All the lines in the spectrum of the Nova are broad, although in a photograph of the spectrum of Arcturus, taken with the same instrumental conditions, the lines were perfectly sharp. It is also important to note that the broadening of the lines is not accompanied by any

falling off of intensity at the edges, as in the case of the hydrogen lines in such a star as Sirius. With the method employed in taking the photographs, long exposures are liable to result in a thickening of all the lines on account of atmospheric tremors. The lines would also be thick if the Nova be hazy. In the photograph, however, all the lines are not equally thick.

If the lines are similarly broadened when a slit spectroscope is employed, the effect must be due to internal agitations, for if different regions of the Nova are moving with varying velocity, or with the same velocity in different directions, a normally fine line might be widened in the manner observed in the photographs.

With regard to the bright and dark lines the paper states as follows:—

"A somewhat similar phenomenon has already been recorded by Prof. Pickering in the case of  $\beta$  Lyræ, and this has been confirmed by a series of photographs taken at Kensington. In this case the bright lines are alternately more or less refrangible than the dark ones, with a period probably corresponding to the known period of variation in the light of the star. The maximum relative velocity indicated is stated by Prof. Pickering as approximately 300 English miles per second.

"In the case of Nova Aurigæ, the dark lines in all four photographs taken at Kensington are more refrangible than the bright ones, so that as yet there is no evidence of revolution.

"The relative velocity indicated by the displacement of the dark lines with respect to the bright ones appears to be over rather than under 500 miles per second. The reduction is not yet complete.

"Should the photographs which may be obtained in the future continue to show the dark lines displaced to the more refrangible side of the bright ones, it will be a valuable confirmation of my hypothesis as to the causes which produce a new star—namely, the collision of two meteor-swarms. On this supposition the spectrum of Nova Aurigæ would suggest that a moderately dense swarm is now moving towards the earth with a great velocity and is disturbed by a sparser one which is receding. The great agitations set up in the dense swarm would produce the dark-line spectrum, while the sparser swarm would give the bright lines."

ELECTRODYNAMIC THEORIES AND THE ELECTROMAGNETIC THEORY OF LIGHT.<sup>1</sup>

IN a former article we endeavoured to give an account of the first part of M. Poincaré's "Électricité et Optique," in which he dealt with the electric and magnetic theories expounded in Maxwell's treatise. In Part II. he now compares the theory of electromagnetic action given by Maxwell with the somewhat more general theory put forward by Helmholtz in his celebrated paper on the equations of motion of electricity (*Pogg. Ann.*, cii. p. 529, or *Wissenschaft. Abhand.*, vol. i.); discusses the condition which must hold in order that the two theories may coincide; and, after a masterly exposition of the various consequences which flow from Maxwell's theory, finishes with a very valuable analysis of the theoretical and experimental work of Hertz.

In the first chapter M. Poincaré deals with the formula of Ampère for the mutual action of two current elements. The method adopted is founded on the following three principles assumed from Ampère's experiments:—

- (1) That a current in a conductor may be replaced by an equal current in a sinuous conductor nowhere deviating from the first by a distance comparable with the distance of the latter from any element of the other conductor acted upon.

<sup>1</sup> "Électricité et Optique." II. Les Théories de Helmholtz et les Expériences de Hertz. Par H. Poincaré, Membre de l'Institut. (Paris: Georges Carré, 1891.)

(2) The action of a closed circuit carrying a current upon any current element is normal to the element.

(3) The action of a closed (non-varying) solenoid upon a current element is zero.

It is besides assumed that the action of a circuit upon a current element is the sum, in the dynamical sense, of the individual actions of the elements of the circuit; and that the action between two elements is a force in the straight line joining their centres.

The process used for the deduction of Ampère's formula from these premises is very elegant. If  $ds, ds'$  be the lengths of the two elements,  $\gamma, \gamma'$  the currents in them,  $\epsilon$  the angle between the elements,  $\theta, \theta'$  the angles they make with the line joining their centres, the action of  $ds$  on  $ds'$  may be represented by  $f(r, \theta, \theta', \epsilon)\gamma\gamma'dsds'$ . But the action of  $ds$  may, by the first principle stated above, be replaced by the actions, of its components  $dx, dy, dz$ ; so that

$$f = A \frac{dx}{ds} + B \frac{dy}{ds} + C \frac{dz}{ds}$$

where A, B, C are coefficients. Now,  $f$  depends upon  $r, \theta, \theta', \epsilon$ ;  $r$  and  $\theta'$  do not depend on the direction cosines of  $ds$ ;  $\cos \theta$  and  $\cos \epsilon$  are linear and homogeneous with respect to these direction-cosines. Hence  $f$  must be linear and homogeneous with respect to  $\cos \theta$  and  $\cos \epsilon$ , that is with respect to  $dr/ds$ , and  $d^2r/dsds'$ . Similarly,  $f$  is linear and homogeneous with respect to  $dr/ds'$ ,  $d^2r/dsds'$ . Hence we have

$$f = \psi(r) \frac{dr}{ds} \frac{dr}{ds'} + 2\phi(r) \frac{d^2r}{dsds'}$$

where  $\psi(r)$  and  $\phi(r)$  are functions of  $r$ .

These functions are determined by the second and third fundamental principles. The second gives  $\psi(r) = \phi'(r)$ , so that the problem is reduced to the determination of  $\phi(r)$ . This value of  $\psi(r)$ , however, permits  $f$  to be written in the form

$$2dU/dr \cdot d^2U/dsds',$$

where U is a function of  $r$  only, and

$$dU/dr = \sqrt{\phi(r)}.$$

From this it is then shown that, if T be the so-called electrodynamic potential (electrokinetic energy) of the circuits—that is, the function the space variation of which, for any direction, is the force in that direction between the circuits—

$$T = \iint \frac{dU}{ds} \frac{dU}{ds'} ds ds',$$

the currents being each unity, and the integrals being taken round the circuits.

The determination of U is then effected by means of the third principle. It is first shown that T may be written as the integral of  $Fdx + Gdy + Hdz$  round the circuit to which  $ds$  belongs, F denoting the integral round the other circuit of  $U^2 ds' dr/ds'$ . ( $x - x'$ ) $r$ , and G, H similar expressions. F, G, H are, in this theory, what Maxwell has called the components of vector potential. These values of F, G, H, it is to be remarked, fulfil the relation

$$dF/dx + dG/dy + dH/dz (= J) = 0.$$

By applying the third principle it is proved that, if  $\nabla^2$  have its ordinary signification, and  $f'(r) = U^2/r$ , ( $U = dU/dr$ ),  $\nabla^2 f(r)$  must be a constant, in order that the action of a closed non-varying solenoid on a complete circuit may be zero. Since  $f(r)$  must be zero at infinity, this gives  $f(r) = k/r$ ; and if the ordinary electromagnetic definition of unit current be taken,  $k$  must be unity, so that  $U = \pm 1/\sqrt{r}$ . Hence the attraction between the elements is

$$2\gamma\gamma'dsds' \frac{1}{r^2} (\cos \epsilon - \frac{3}{2} \cos \theta \cos \theta'),$$

Ampère's well-known expression.

The above expressions for F, G, H reduce easily to  $\int f(r)dx', \int f(r)dy', \int f(r)dz'$ , so that, putting in the value of  $f(r)$ , we get the well-known value of the mutual energy of the two circuits—

$$T = \iint \frac{\cos \epsilon}{r} ds ds'.$$

The theory of induction is next taken up. After a short discussion of some objections made by M. Bertrand to the received method of deducing the laws of induction from the observed facts of electromagnetism, M. Poincaré proceeds to show that the electrokinetic energy of two currents is equal to the electrodynamic potential, and recalls Maxwell's application of Lagrange's dynamical equations to the theory of inductive action. He then deals at some length with the celebrated theory put forward by Weber for the action between two quantities,  $e, e'$ , of electricity, as depending on their distance apart and their motion.

This we pass over, with the remark that Poincaré here discusses certain difficulties to which the theory leads in connection with the value it gives for the action between two current elements, and concludes with a short analysis of Maxwell's examination of the theory of induction as deduced from Weber's law. According to Maxwell ("El. and Mag.," vol. ii. p. 445, second edition), Weber's theory gives, for the inductive electromotive force exerted by the circuit in which the current  $\gamma$  flows on the other, the equation—

$$E = \frac{d}{dt} \iint \gamma \frac{1}{r} \frac{dr}{ds} \frac{dr}{ds'} ds ds',$$

which, for a closed circuit, agrees with the well-known equation—

$$E = - \frac{d}{dt} \iint \gamma \frac{\cos \epsilon}{r} ds ds'.$$

M. Poincaré points out that this apparent agreement of the two theories is due to the fact that Maxwell has overlooked certain terms which contribute to the value of E, and which do not give a zero result when integrated round a closed circuit.

The expressions given by Weber and Neumann for the mutual potential of two current elements are next considered, and shown to be included in the general expression given for the same potential by Helmholtz. By means of this expression Helmholtz's general electrodynamic theory is introduced, and then follows an elaborate comparison of the theories of Helmholtz and Maxwell. It is shown that Helmholtz's theory leads to the value of T for conduction in three dimensions given by the equation—

$$T = \frac{1}{2} \int (Fu + Gv + Hw) d\omega,$$

where  $d\omega$  is an element of volume,  $u, v, w$  the components of currents, and the integral is extended throughout all space. F, G, H, are, of course, the components of vector potential, and in this theory are given by equations—

$$F = \int \gamma' dx'/r + \frac{1}{2}(1 - k)d\psi/dx, \&c.,$$

where

$$\psi = \int \gamma' ds' \cdot dr/ds'.$$

If  $\rho$  be the density of free electricity at any point,

$$du/dx + dv/dy + dw/dz = - \rho/dt,$$

and this, when instead of  $\gamma' dr/ds'$  is substituted its value in terms of  $u', v', w'$ , gives, by an application of Green's theorem, the result—

$$\psi = \int r d\rho/dt \cdot d\omega',$$

where  $d\omega'$  is an element of the space in which the current

$\gamma'$  is flowing. Now, if in the insulating dielectric two like quantities of electricity,  $e, e'$ , would produce a repulsive force of magnitude  $ee'/\lambda r^2$ , the electrostatic potential  $\phi$ , due to the free electricity of density  $\rho$ , is given by the equation—

$$\lambda\phi = \int \rho' d\omega'/r.$$

Thus, from the foregoing values of  $F, G, H$ , three equations are obtained, viz.,

$$\nabla^2 F = -4\pi u + (1 - k)\lambda d^2\phi/dx^2,$$

with two similar equations for  $\nabla^2 G$  and  $\nabla^2 H$ . These give

$$dF/dx + dG/dy + dH/dz = -k\lambda d\phi/dt,$$

which is zero if  $k$  or  $\lambda$  be zero.

If, now, the magnetic inductive capacity be taken for the moment as unity, and the magnetic force ( $\alpha, \beta, \gamma$ ) be so defined that  $T$  is  $\gamma$  times the magnetic induction through the circuit in which the current whose numerical magnitude is  $\gamma$  flows, we deduce easily the equations—

$$\alpha = dH/dy - dG/dz, \text{ \&c.;}$$

so that there follow

$$\begin{aligned} \frac{d\gamma}{dy} - \frac{d\beta}{dz} &= 4\pi u - \lambda \frac{d^2\phi}{dx^2} \\ \text{\&c.}, & \quad \text{\&c.} \end{aligned}$$

These coincide with the equations of currents given by Maxwell when the last terms are omitted. We must therefore either put  $\lambda = 0$ , or (since  $d\phi/dt$  is not in general zero)  $\phi = 0$  to reduce to Maxwell's theory.

Poincaré next proves that unless the  $k$  in Helmholtz's theory be not less than zero, the sum of the electrostatic and electrokinetic energies may diminish indefinitely from an infinitely small value, so that there would be unstable equilibrium. This affords another reason for rejecting the theory of Weber, in which  $k = -1$ .

In chapter v. Poincaré passes from the theory of Helmholtz to that of Maxwell. He first considers magnetic and dielectric polarization according to a modified and corrected version of the theory of Poisson. He supposes the dielectric space filled with conducting particles separated by other material, the dielectric proper, which completely insulates these bodies from one another. These conducting bodies are supposed to be electrically polarized, so that electric displacement ( $f, g, h$ ) is set up in the medium. A parallel theory of magnetic polarization is considered, and the electric displacement is simply the electric analogue of the intensity of magnetization of the medium—that is, the magnetic moment at each point per unit of volume. If  $\epsilon$  be the ratio of the volume occupied by the conducting particles to the whole volume of the dielectric space in which they are embedded, the specific inductive capacity,  $K$ , of the medium is found to be  $\lambda\phi(\epsilon)$ , where  $\phi(\epsilon)$  is a function analogous to  $(1 + 2\epsilon)/(1 - \epsilon)$  (the corresponding function for the case in which the conducting particles are spheres) in that it becomes infinite when  $\epsilon = 1$ .

According to Poincaré,  $\lambda$  is the specific inductive capacity of the dielectric medium proper, or insulator between these conducting bodies, and is very small. In order, therefore, that  $K$  may be finite, it is necessary that  $\epsilon$  may be very nearly equal to unity.

The electrostatic potential,  $\phi$ , at any point is that due to the free electricity present on conductors, and to the electricity developed throughout the medium by its polarization. The electrification, in fact, consists of two parts—a volume density on the dielectric depending on the electric displacement, and of amount  $-(df/dx + dg/dy + dh/dz)$ , and a resultant surface density,  $\sigma' = \sigma - (lf + mg + nh)$ , where  $\sigma$  is the surface density of the electricity present in the form of charges on conductors, and  $lf + mg + nh$  (in which  $l, m, n$  are the direction cosines of the normal to the surface directed inwards

towards the dielectric) is the surface distribution due to the polarization. By speaking of this as the electrification, what is meant is that this electrification existing in the dielectric medium proper would give the observed potential,  $\phi$ , at each point. Thus

$$\phi = \frac{1}{\lambda} \left\{ \int \frac{d\omega}{\rho r} + \int \sigma' \frac{dS}{r} \right\}.$$

The value of the electrostatic energy,  $U$ , according to this dielectric theory, is given by

$$U = \frac{\lambda}{8\pi} \int \Sigma \left( \frac{d\phi}{dx} \right)^2 d\omega + \frac{2\pi}{K - \lambda} \int \Sigma f^2 d\omega.$$

If there are applied electromotive forces,  $X, Y, Z$ , their values are given by

$$X = -d\phi/dx - 4\pi f/(K - \lambda),$$

with similar equations for  $Y$  and  $Z$ . Hence, if  $X, Y, Z = 0$ —that is, if there is nothing but electrostatic action—the electrostatic energy is given by

$$U = \int \frac{K}{8\pi} \Sigma \left( \frac{d\phi}{dx} \right)^2 d\omega.$$

If  $X, Y, Z$  are not zero, the electrostatic energy becomes  $2\pi/K \cdot \int \Sigma (f^2) d\omega$  (which is Maxwell's expression), provided  $\lambda = 0$ . We have to inquire what reasons can be adduced for putting  $\lambda = 0$  in this theory.

M. Poincaré shows that the velocity of propagation of a wave of longitudinal displacement in Helmholtz's theory is  $\sqrt{K/(K - \lambda)}\lambda$ . On the other hand, the velocity of propagation of a wave of transverse displacement is  $\sqrt{1/\mu(K - \lambda)}$ . Thus there will be no longitudinal wave if one of the conditions,  $k = 0, \lambda = 0, K = \lambda$ , hold. The last condition would make the velocity of propagation of waves of transverse displacement infinite, and must be rejected for every medium, even so-called vacuum, in which light is propagated. Poincaré adopts the second hypothesis.

Further, if to  $\lambda$  a positive value sensibly greater than zero be assigned, a wave of transverse displacement will be given a velocity sensibly greater than that of light. Thus, to pass to Maxwell's theory, it is necessary to make  $\lambda$  insensible, as this gives for the velocity of waves of transverse displacement his value  $1/\sqrt{\mu K}$ , which is known by experiment to be the velocity of light.

The adoption of this value of  $\lambda$  leads to all the electromagnetic equations of Maxwell, and to the conditions  $J = 0, du/dx + dv/dy + dw/dz = 0$ , the last of which expresses that electricity considered as the analogue of a fluid is incompressible—that is, that all currents flowing are closed currents.

It may be pointed out here that this conclusion agrees with that arrived at by Mr. R. T. Glazebrook in his comparison of Maxwell's electromagnetic equations with those of Helmholtz and Lorentz, and in his further paper on the general equations of the electromagnetic field (Proc. Camb. Phil. Soc., vol. v., Part ii., 1884). Mr. Glazebrook's result is that  $\phi$ , the electrostatic potential of Helmholtz's paper must be zero everywhere in order to pass from Helmholtz's theory to that of Maxwell. But  $\phi$  is what Poincaré has denoted by  $\lambda\phi$ , so that the conditions are the same.

It has been attempted to make the transition to Maxwell's theory by putting  $k = 0$ . This would not suffice alone, as Poincaré points out. For, while giving at once  $J = 0$ , it would fail to give Maxwell's velocity for transverse waves unless further  $\lambda = 0$ , which by itself would suffice to effect the transition irrespective of the value of  $k$ .

Poincaré thus supposes, in opposition to the older dielectric theories, that even vacuum, or the ether of the inter-planetary spaces, consists of polarizable conducting matter embedded in an insulating medium of infinitely small inductive capacity,  $\lambda$ . According to

Mossotti's theory, which is the starting-point of all mathematical theories of polarization, the conducting particles are spherical, and therefore, if  $\epsilon$  be the ratio of the volume of the spheres to the total volume of the medium, the value of  $K$  is  $(1 + 2\epsilon)/(1 - \epsilon)$ . It is here assumed that the specific inductive capacity of the insulating dielectric is unity. Poincaré, however, sees no reason for making this particular assumption, and takes it as  $\lambda$ , a quantity which, if Maxwell's theory be the true one, must be exceedingly small. This involves, as already stated,  $K = \lambda\phi(\epsilon)$ , where  $\phi(\epsilon)$  is a quantity which becomes very great when  $\epsilon = 1$ . Thus, according to Maxwell's theory, the conducting particles are separated by infinitely thin insulating partitions, so that they practically fill the whole space. Of course, the physical fact may be very different from that here supposed: the theory only furnishes a picture, not perhaps altogether clear and intelligible, of the structure of the medium and its functions.

It may be said that the infinitely small inductive capacity,  $\lambda$ , of the medium, itself requires physical explanation. This is quite true; but so also does the specific inductive capacity equal to unity assumed for vacuum or air in the ordinary theories. In fact, such dielectric theories as have been put forward, involving merely polarization of the medium, only give an explanation of the difference between the electric behaviour of one medium and another, and furnish none whatever of the real *rationale* of the propagation of electric action.

That the value of  $\phi$  may be finite, it is necessary that the values of the volume density,  $\rho$ , and the surface density,  $\sigma$ , may be infinitely small, since

$$\phi = \int \frac{\rho}{\lambda r} d\omega + \int \frac{\sigma}{\lambda r} ds.$$

Here  $\rho$  is the volume density due to the surface distributions on the opposite faces of the partitions between the conducting particles, and this, it is easy to see, will be infinitely small. Also,  $\sigma'$  is the sum of the actual density (surface density of charge) on the surface of the conductors, and the density, which is the surface manifestation of the polarization of the conducting particles, or  $\sigma = \sigma - (Y + mg + nh)$ . This also can be conceived as exceedingly small, so that  $\phi$  may have a finite value.

Further reasons for preferring the theory of Maxwell are discussed in chapter vi, which is entitled "The Unity of Electric Force." This chapter consists of an exposition of Hertz's modification of Maxwell's electromagnetic theory—a modification, it is to be remarked, practically given also, but in vector form, by Mr Oliver Heaviside, in various papers in the *Philosophical Magazine*. When made, it exhibits a striking parallelism between the equations of electric and magnetic force, and leads to some remarkable theorems. Using Maxwell's equations, and deviating slightly from Poincaré's mode of presenting the equations, we have, if  $k$  now denote electric conductivity of the medium, and  $P, Q, R$  components of electric force—

$$\left(k + \frac{K}{4\pi} \frac{d}{dt}\right) P = \frac{1}{4\pi} \left(\frac{dy}{dy} - \frac{d\beta}{dz}\right),$$

with two similar equations for  $Q$  and  $R$ . But also we have—

$$\frac{\mu}{4\pi} \frac{d\alpha}{dt} = -\frac{1}{4\pi} \left(\frac{dR}{dy} - \frac{dQ}{dz}\right),$$

with two similar equations for  $\beta$  and  $\gamma$ . These last may, by the introduction of a non-existent quantity,  $g$ , be written—

$$\left(g + \frac{\mu}{4\pi} \frac{d}{dt}\right) \alpha = -\frac{1}{4\pi} \left(\frac{dR}{dy} - \frac{dQ}{dz}\right),$$

$$\&c., \quad \&c.$$

The quantity  $g$ , Heaviside points out, is the proper magnetic analogue to  $k$ , and may therefore be called the magnetic conductivity. Its reciprocal would be the

true magnetic resistivity of the medium. Of course, in an insulating medium  $k$  is also zero.

According to Maxwell's theory,  $P, Q, R, \alpha, \beta, \gamma$  fulfil the equations—

$$\frac{dP}{dx} + \frac{dQ}{dy} + \frac{dR}{dz} = 0,$$

$$\frac{d\alpha}{dx} + \frac{d\beta}{dy} + \frac{d\gamma}{dz} = 0;$$

the first, since  $du/dx + dv/dy + dw/dz = 0$ , and the second because the magnetic force in the medium, being supposed purely inductive, must fulfil the solenoidal condition, except at the (vortex) origin of the disturbance.

There is therefore, in Maxwell's theory, a perfect reciprocity of relation between the electric and magnetic quantities. Hence we might infer, from the magnetic phenomena following from electric currents or flow of electricity, an analogous set of electric phenomena following from the flow of magnetism. Now we know that if a magnet varies in strength it produces an electromotive force of components  $P, Q, R$ , at every point of the surrounding space. This we may suppose due to a current of magnetism flowing from one end of the magnet to the other, and thus producing the variation in the magnet's strength. The directions of the components of electric force at any point are in fact coincident with those of the components of vector potential produced by the magnet at that point, and are equal to the time-rates of variation of these components. But why should this not be regarded as an electrostatic field in the ordinary sense of the term? For example, a current of electricity, flowing round a closed circuit, produces a magnetic field equivalent to that which would be produced by a magnetic shell of proper strength, and having its edge coincident with the circuit. Of this current a closed solenoid varying continuously in magnetic strength (for example, a closed solenoid in which the magnetizing current is varying in strength) is the magnetic analogue, and ought in the same way to be equivalent to an *electric shell*, in the sense of producing an identical electric field. Such a shell ought to be subject in an electric field to dynamical action; and further, two such varying solenoids ought to exert the same mutual dynamical action, as would the two equivalent electric shells if placed in the same configuration. The second of these conclusions asserts that the dynamical action on such a shell depends only on the electric field in which it is placed, and that its action on the other varying solenoid is due to its producing exactly the same electric field as the equivalent electric shell would produce. This is what Poincaré gives as Hertz's principle of the unity of electric force.

Of course, it is to be noticed that the second conclusion does not follow from the first. We cannot reason that because the mutual action of an electric shell and a varying solenoid is the same as that of two electric shells, therefore the mutual action of two solenoids is the same as that of two electric shells.

If, however, we assume that the dynamical action on a closed varying solenoid depends only on the electric field in which it is placed, we can say that the mutual action of two varying solenoids is the same as that of their equivalent electric shells.

M. Poincaré calculates the work done in effecting a relative displacement of two such varying solenoids, and finds that it is equal to the change in the electrostatic energy of the system, as the change in the electrokinetic energy is all accounted for otherwise. Now, the electrostatic energy of a system is given as we have seen by the equation—

$$U = \int \left\{ \frac{\lambda}{8\pi} \sum \left(\frac{d\phi}{dx}\right)^2 + \frac{2\pi}{K - \lambda} \sum (f^2) \right\} d\omega,$$

where

$$f = - (K - \lambda)/4\pi \cdot dF/dt + \dot{\alpha}\phi/dx.$$

This may be written

$$U = \int \left\{ \frac{\lambda}{8\pi} \sum \left( \frac{d\phi}{dx} \right)^2 + \frac{K - \lambda}{8\pi} \sum \left( \frac{d\phi}{dx} + \frac{dF}{dt} \right)^2 \right\} d\omega.$$

Now, if there be no inductive action—that is, if the field be wholly electrostatic—

$$dF/dt, dG/dt, dH/dt = 0,$$

and hence, for two electric shells—

$$U = \int \frac{K}{8\pi} \sum \left( \frac{d\phi}{dx} \right)^2 d\omega.$$

On the other hand, if the action be wholly inductive—that is, if we have no so-called electrostatic action—

$$d\phi/dx, d\phi/dy, d\phi/dz = 0,$$

and for two varying solenoids we have—

$$U' = \int \frac{K - \lambda}{8\pi} \sum \left( \frac{dF}{dt} \right)^2 d\omega.$$

If, then, there be the same mutual action between the two varying solenoids as between their equivalent electric shells, we must have  $U = U'$ . But because of the equivalence the value of  $dF/dt$ , &c., produced at any point by either solenoid, must be the same as those of  $d\phi/dx$ , &c., produced at the same point when the solenoid is replaced by its equivalent electric shell. Thus we get  $U/U' = K/(K - \lambda)$ , and therefore  $\lambda = 0$ . Thus, if the principle of the unity of electric force is true,  $\lambda = 0$ , and we have Maxwell's theory.

Dr. Oliver Lodge has, as is well known, endeavoured to detect the existence of an electrostatic field produced by varying magnetic action (NATURE, May 23, 1889, and *Electrician*, May 17, 1889), and has reason to believe that he has been successful. It is also possible, as Poincaré suggests, that this kind of electrostatic action may be developed when iron rings, &c., are placed in the field of an alternating electromagnet, as in the experiments of Elihu Thomson.

In a note, which forms a supplement to the comparison of the theories of Helmholtz and Maxwell, M. Poincaré points out that when the mutual action of a varying solenoid and an electric shell is considered, contradictory results are obtained according as the solenoid is regarded as fixed and the shell movable, or the shell fixed and the solenoid movable. Thus the theory of Helmholtz in this application does not give fulfilment of the third law of motion.

Possibly, some such theory as this may throw some light on the electric phenomena of voltaic cells, with their finite steps of potential across the surfaces of separation of dissimilar substances, and help to refer the production of all currents to the single cause—electromagnetic action.

We come now to the discussion which the book contains of the experiments of Hertz. This fills considerably more than one-half of the work, and we cannot, in the space left at our disposal, give an adequate account of it. Of the experiments themselves it is not necessary to say anything, as they have been fully and ably discussed in NATURE by Mr. Trouton (February 21, 1889). Hertz's own theory of the radiation of electric and magnetic energy has also been given in these pages by Dr. Lodge (February 21, 1889, *et seq.*). Poincaré's presentation of the theory is, however, marked by many points of originality, and abounds in acute and interesting remarks.

The theory of the dumb-bell exciter used by Hertz is first considered, then the field produced is discussed, and, last of all, the action of the resonator or receiver is dealt with. Taking the exciter as a couple of spheres, 15 cms. in radius, placed with their centres 150 cms. apart, and joined by a wire  $\frac{1}{2}$  cm. in diameter, Poincaré calculates (1) the capacity, (2) the self-induction of the arrangement. The value of the capacity of the arrangement of two

spheres used by Hertz in the calculation of the period of the exciter was that of each of the spheres by itself, viz. 15 cms. Now, if one of the spheres were alone in its own field with a charge  $q$  and at a potential  $V$ , we should have  $q/V = 15$ . But at any instant when the charge of one sphere is  $q$ , that of the other sphere is  $-q$ ; and since the spheres may be taken as nearly without mutual influence, the difference of potential between them is 2V. The capacity is, then,  $q/2V$ , or 7.5 cms.—half the value used by Hertz. That this is the proper value to use for the capacity is easily verified by a reference to the mode of establishing the equation of oscillation, when it is seen that the capacity is really defined by that equation as the charge on one of the spheres divided by their difference of potential.

The calculation of the self-induction given by Poincaré is interesting. Regarding, as an approximation, the currents in the spheres, and the influence of the spark-interval, as negligible, and taking the wire as of length  $l$  (equal to the distance between the centres of the bulbs), and of diameter  $d$ , and assuming that the current is wholly on the surface of the wire (which it is approximately, when in rapid alternation) he finds—

$$L = 2l \left\{ \log \frac{4l}{d} - 1 + \frac{k-1}{2} \right\},$$

where  $k$  is the quantity which appears in Helmholtz's theory.

This differs from the value given by Hertz in having  $-1$  for the middle term within the brackets instead of  $-75$ , and  $(k-1)/2$  instead of  $(1-k)/2$  for the third term. The first discrepancy arises through the currents having been taken by Hertz as uniform over the cross-section of the wire, and the second probably through an error in sign. The self-induction,  $L$ , is 1902 cms. if the term involving  $k$  is not taken into account, and  $(1902 + 150)$  cms. if  $k$  be put equal to zero.

Calculating the period  $T (= 2\pi\sqrt{LC})$ , where  $C$  is the capacity in electromagnetic units, we find it to be  $2.51 \times 10^{-8}$  seconds, and multiplying by the ratio of the electromagnetic unit of quantity to the electrostatic unit, or  $v$ , we get for the wave-length 7.53 metres. Hertz gives 1.77 for the calculated half period, and 5.31 for the corresponding half wave-length. On account of the error in the estimation of the capacity, it is clear that this value of the half period and half wave-length must be divided by  $\sqrt{2}$ , and this brings them into agreement with the values first stated. There is, however, a serious discrepancy between the results of theory and experiment, which we shall notice presently.

The calculation of period, &c., of course proceeds on the assumption that the resistance is negligible, and this is no doubt the case to a sufficient degree of approximation. In the theory itself, also, no account is taken of the induction coil or of the displacement currents in the dielectric; further, the energy is dissipated, not merely by the production of heat, but by radiation into the dielectric. That the influence of the induction coil is indeed negligible Poincaré gives reasons for supposing; in fact, on account of the enormous self-induction of the induction bobbin, and the small mutual induction of the exciter and the bobbin, the corrected differential equation is the one formerly found for the oscillation, with the addition of an exceedingly small term, so that the solution is practically the same as before. (Here, p. 162, the expression "a étant très grand" should be "a étant très petit"). As Poincaré states, the vibration of the exciter is like that of a very small pendulum attached to a massive pendulum of long period; the period of the former is very little affected by its mode of support. For a similar reason the period is very little affected by the very considerable capacity of the bobbin.

Experimenting on the velocity of propagation of electro-

magnetic waves, Hertz found that the half wave-length in air was about 4.5 metres, the corrected period of the vibrator used being about  $2 \times 10^{-8}$  seconds. This gives a velocity of propagation of  $900/(2 \times 10^{-8})$  (or  $4.5 \times 10^{10}$ ) cms. per second, exceeding the velocity of light by about 50 per cent. For the wave-length in wires, however, he found a value which gives a velocity of propagation nearly equal to the velocity of light, when the correction of the period for error in capacity is taken into account. (Later, M. Poincaré gives the half wave-length in air for these experiments as 4.8 metres.)

Herr Lechner, experimenting at Vienna, has also found a velocity of propagation in wires very approximately equal to the velocity of light, which thus confirms Hertz's result. On the other hand, M.M. Sarasin and de la Rive, experimenting at Geneva in 1890, found that the wave-length observed depends very much on the dimensions of the resonator. But using an exciter exactly similar to that of Hertz, and of the same dimensions, and a resonator 75 cms. in diameter, and therefore nearly an exact copy of that employed by Hertz, they found a half wave-length of 3 metres, instead of 4.8 metres as found by Hertz. Thus there is a discrepancy between the two results which it is difficult to explain. Hertz himself gives a possible explanation, in a letter to M. Poincaré which is quoted in a note on some recent experiments which is printed as an appendix. On account of its interest, we take the liberty here of translating the extract quoted. It is to be noted that what is called the wave-length here is the distance from node to node, or half the complete wave-length.

"It is difficult for me to believe that I have been misled in the second method into finding 4.8 metres instead of 3 metres; but since the result of Messrs. Sarasin and de la Rive has every theoretical appearance of truth, I have endeavoured to find out the cause of the difference. Here are two ways of explaining it. The waves were produced between two parallel walls of a room, and I have taken account of the reflective action of only one of them. Let us suppose, to begin with, that the length of the room is an exact multiple of the wave-length, say three wave-lengths. We shall have two well-marked nodes at the exact distance. If the length of the room is four wave-lengths, we shall have three well-marked nodes. But if the length of the room is intermediate between these, and nearer the former than the latter, we shall have two less distinct nodes at a distance apart greater than a wave-length. This explanation would appear to me satisfactory, if the difference were not too great.

"The other way of explaining the difference is this. My reflecting plate of zinc was fixed in a niche in the wall, and it is possible that the projecting parts of the wall may have had the effect of carrying off the nodes to a greater distance from the wall, and thus of giving too great an apparent length as measured. But it is also true that the niche was from 5 to 6 metres in width, and it does not seem to me very probable that it can have had any great effect.<sup>1</sup>

"I therefore cannot tell precisely the cause of my error; but I believe there must be some way of explaining it. For a long time I have sought in vain to find a probable cause for the difference of velocity in air and in wires; and I had myself found, before Messrs. Sarasin and de la Rive, that there is no difference for short waves of 30 cms. in length. The results of these gentlemen, however, give the same velocity for long waves, and contradict my experiments."

Connected with this point M. Poincaré has some instructive remarks on what Messrs. Sarasin and de la Rive have observed and called multiple resonance, and which

<sup>1</sup> For an interesting discussion of the effects of reflecting plates of different dimensions, see a paper by Mr. Trouton in the *Phil. Mag.*, July 1891.

has also been observed by Fitzgerald and Trouton. Their supposition is that the exciter gives rise neither to a single vibration of distinct period, nor to a limited number of distinct vibrations, but rather to such a complex of vibrations as would give a wide band of continuous spectrum. Thus all vibrations, agreeing with possible modes of vibration of the resonator would be reinforced. That this explanation is not borne out by the theory is true, but on account of the incompleteness of the theory it is not possible to attach much weight to this fact. It is hard to believe that the vibrations can be perfectly simple.

Poincaré proposes, however, the following explanation. For various reasons, he thinks the logarithmic decrement of the vibrations of the exciter is probably much greater than that of the resonator, and so the vibrations of the exciter diminish in amplitude more quickly than those which by any cause are set up in the resonator. Thus the resonator, being started by the exciter, would continue its vibrations after those of the exciter had become insensible, but would then vibrate in its own proper period, thus giving vibrations of longer period and of greater wave-length than those which excited it. The wave-length, being determined by interference, and used with the too short period of the exciter, would of course give too great a velocity of propagation. With this explanation Hertz has expressed himself as practically in accord, and so a possible way out of the difficulty seems opened up. As Hertz remarks, the oscillations of the exciter, represented graphically, do not give a curve of sines pure and simple, but a curve of sines the amplitude of which gradually diminishes. Such an oscillation will cause all resonators receiving it to vibrate, but those in tune with the exciter more violently than the others. A mathematical investigation of the point is given by M. Poincaré, which explains the result, shown by experiment, that the apparent spectrum found by Sarasin and de la Rive seems more extended when wires are connected to the vibrator, than when the propagation takes place freely in air.

Whether this explanation be satisfactory or not, there can be no doubt, on the whole, that the electromagnetic theory of light is substantially true. The theory is far from complete, and there are many outstanding points which require further theoretical and experimental elucidation. Some of these are touched on by Poincaré in his discussion of the field produced by exciters of different forms, and the theory of the resonator, but especially in a valuable series of notes which he has added to his lectures. These deal with special topics, which are there treated with more detail than was possible in the body of the work. Such, for example, are his notes on multiple resonance, the calculation of the period, and the propagation of waves in sinusous waves.

This article has run to too great a length, and must here close. M. Poincaré's work ought to be read by everyone interested in Maxwell's great scientific generalization—the greatest, perhaps, ever made by a natural philosopher since the days of Newton—and in its remarkable experimental verification by Hertz. There never was, perhaps, a time of greater mathematical and physical activity than the present, but withal it is marked by a care for the scientific student which no previous age ever displayed. It is no small encouragement to humbler scientific workers when masters of analysis like M. Poincaré take the trouble to publish, in a connected form, their lectures and researches on the current scientific questions of the day. Besides earning the gratitude of those who are thus admitted within the circle of their pupils, by immediately communicating their discoveries and expositions in this manner to the general scientific public, they multiply many-fold the direct effect of their work on scientific progress.

A. GRAY.

ON SOME POINTS IN ANCIENT EGYPTIAN ASTRONOMY.<sup>1</sup>

## II.

## 4.—The Probable Date of the Founding of Denderah as derived from the Account of the Building Ceremonial.

SO much having been stated relating to the inscriptions recording building ceremonials, I will now return to the statement regarding Denderah, to see what can be made of it on the view that either the middle or the chief point—that is, the brightest star of the constellation of the Great Bear as we now know it—was the part referred to, and that the cord was stretched to the star on the horizon.

The first question which arises is, Was there any reason why  $\delta$  Ursæ Majoris at the centre, or  $\alpha$  the brightest, should have been used as the orientation point at any time? Was there any reason why any special sanctity should have been associated with either? Certainly not in the case of  $\delta$  on account of its magnitude, because Dubhe, not far from it, is much brighter. And certainly not in the case both of  $\delta$  and  $\alpha$  on account of their heliacal rising. We seem therefore in an *impasse* along this line of inquiry, but a further consideration of the question brings out the remarkable fact that at two different points of time the North Polar distance of  $\alpha$  Ursæ Majoris was nearly the same as that of  $\alpha$  Lyræ and  $\gamma$  Draconis, so that a Lyræ would be visible at one of the dates and  $\gamma$  Draconis with  $\alpha$  Ursæ Majoris at the other—all rising in the same amplitude.

The stars rising at the same amplitude, a temple directed to one would be directed to the other, but the stars would rise at different times. This, it may be suggested, may have been the reason why  $\alpha$  was used by the king: the most convenient hour of the night was chosen. But there may have been another reason.

We know enough of the Egyptian priests to imagine it might be to their interest that even the king himself should not know everything, and the question arises whether, knowing the equal amplitudes of the risings of these stars, the secret was retained while  $\alpha$  Ursæ Majoris was used.

This, of course, can only be put forward as a suggestion, and to many, no doubt, it will seem to be far-fetched; but from the account given by Herodotus of some of the ceremonials and mysteries connected with the temple of Tyre, it is suggested that the priests used star-light at night for some of their operations very much in the same way as they might have used sunlight during the day. According to Herodotus, in the temple in question there were pillars of gold and emerald which shone at night. Now, there can be little doubt that in the darkened sanctuary of an Egyptian temple the light of  $\alpha$  Lyræ, one of the brightest stars in the northern heavens, rising in the clear air of Egypt would be quite strong enough to throw into an apparent glow such highly reflecting surfaces as those to which Herodotus refers.

Supposing such a ceremonial as this used at Denderah, the less the worshippers—who, reasoning from the analogy of the ceremonial termed the manifestation of Râ,<sup>2</sup> would stand facing the sanctuary with their backs to the chief door

<sup>1</sup> Continued from p. 299.

<sup>2</sup> One of the inscriptions relating to the manifestation of Râ has been translated by de Rougé as follows:—

"Il vint en passant vers le temple de Râ; il entra dans le temple en adorant (deux fois). Le ver-beh (celebrant) invoqua (celui qui) repousse les plaies du roi; il remplit les rites de la porte; il prit le seteb, il se purifia par l'encens; il fit une libation; il apporta les fleurs de Habeben (la part de la temple); il apporta le parfum (?). Il monta les degrés vers l'adytum grand, pour voir Râ dans Habeben; lui-même se tint seul; il poussa le verrou; il ouvrit les portes; il vit son père Râ dans Habeben; il vénéra la barque de Râ et la barque de l'um. Il tira les portes, et posa la terre sigillaire (qu'il) scella avec le sceau du roi. Lui-même ordonne aux prêtres, 'J'ai placé le sceau; que n'entre pas quelqu'un dedans de tout roi qui se tiendra (là).'"—Chrestomathie Egyptienne, de Rougé, iii. p. 60.

of the temple—knew about the question of a bright star which might probably produce the mystery the better; so that it may be almost said that the priests had a reason, and a very good one, for using a comparatively faint star for the orientation of a temple, some of the uses of which were to utilize for their own purposes some of the phenomena presented by a bright one rising at the same amplitude. These considerations have, however, only full force as between  $\alpha$  Ursæ Majoris and  $\alpha$  Lyræ.

Of course, so far, nothing can be said with certainty with regard to either of the stars in question having been chosen for the original orientation, but in an inquiry of this kind no line of evidence is to be neglected.

We next come to possible dates. Taking the amplitude of Denderah as  $73^\circ$ , the dates of foundation given by either  $\alpha$  Lyræ or  $\gamma$  Draconis will be those at which these stars had an equal amplitude.

Roughly, and only roughly, these dates would have been as follows:—

				Horizon $2^\circ$ high
$\alpha$ Lyræ	...	...	...	7200 B. C.
$\gamma$ Draconis	...	...	...	4400 B. C.

Now, what are the records concerning this temple? We know that the structure now visible to us was built in the time of the last Ptolemies and the first Roman Emperors, and I have already shown that at those dates the Great Bear (the old Thigh) did not rise at all, as it was circumpolar.

But it is also known that there was a temple here in the time of Thotmes III., and even earlier, going back to the earliest times of Egyptian history. King Pepi, of the 6th dynasty (*circa* 3233 B.C.), is portrayed over and over again in the crypts.

Even this is not all the evidence in favour of a high antiquity. In one of the crypts (No. 9), according to Ebers and Dümichen there are two references to the earliest plans of the temple. One inscription states that the great ground-plan (*Senti*) of Ant (Denderah) was found in old writing on parchments of the time of the followers of Horus (sun-worshippers) preserved in the walls of the palace during the reign of King Pepi. Another inscription goes further, referring to the restoration by Thotmes III. (*circa* 1600 B.C.) of the temple to the state in which it was found described in old writings of the time of the King Chufu (Cheops) of the 4th dynasty (*circa* 3733 B.C.). If any faith is to be placed in this inscription, it seems to me to suggest a still higher antiquity. There would have been more reason for describing an antique shrine than a brand new one, and the date 4400 is well within the historical period, according to Mariette.

If, then, I am right in my suggestion as to the word *ak* referring to  $\alpha$  Ursæ Majoris, and as to a star rising at an equal amplitude to  $\gamma$  Draconis being for some reason made use of in the building ceremony, we find the closest agreement between the astronomical orientation, the definite statement as to a certain star being used in the building ceremonies, and the inscription in the crypts referring to Cheops as the earliest historical personage who describes the building. I must confess that this complete justification of the double record strikes me as very remarkable, and I think it will be generally conceded that further local observations should be made in order to attempt to carry the matter a stage further.

If the above results be confirmed we have a most important indication of the fact that in the rebuilding in the time of Thotmes III. and of the Ptolemies, the original orientation of the building was not disturbed, and that in the account of the building ceremonies we are dealing as surely with the laying of the first foundation stone as we are dealing with the original plan.<sup>1</sup>

<sup>1</sup> On this point I am permitted by Prof. Maspero to print the following extract from a letter I received from him:—

"Tous les temples ptolémaïques et la plus grande partie des temples pharaoniques sont des reconstructions. Ce que vous avez observé de

Here, however, it is necessary to proceed with caution, for the last word may not yet have been said when we accept  $\gamma$  Draconis.

I have elsewhere pointed out that it is not impossible that a temple once oriented to a certain star, and long out of use on account of the precessional movement, may be utilized for another, and be rehabilitated in consequence, when that same movement brings another conspicuous star into the proper rising amplitude.

In the present case, the orientation fits  $\gamma$  Draconis in the historic period, but it also fits a Lyrae in the times of the Hor-schesu, the dimly seen followers of Horus, or sun-worshippers, before the dawn of the historic period. If we assume that the record is absolutely true (and I for one believe in these old records more and more), and that Cheops only described a shrine founded by the Hor-schesu, then we are carried back to *circ.* 7000 B.C. I am indebted to my friend Dr. Wallis Budge, for the suggestion that the position of Denderah on the highway from the Red Sea—which may soon be reached by a railway from Keneh to Kosseir!—would make it one of the most important places in Ancient Egypt.

In any case the consideration has to be borne in mind that the series of temples with high northern and southern amplitudes at Denderah, Abydos, Thebes, Philæ, Edfu, were nearly certainly founded before the time at which the heliacal rising of Sirius, near the time of the summer solstice, was the chief event of the year, watched by priests, astronomers—if the astronomers were not the only priests—and agriculturalists alike. Now we know from Biot's calculations that this first took place *circ.* 3285 B.C., and that Sirius—though, as I am informed by Prof. Mascipéro, *not* its heliacal rising—is referred to on inscriptions in pyramid times. The Sirius temples at Thebes, Philæ, and Denderah, are in all probability of much later foundation than those to which I have referred, and that at Denderah seems from its orientation to be the latest of all.<sup>1</sup>

I will, however, leave for a future occasion the question of the original Hor-schesu shrine, and consider at present an important relation between the chief temple at Denderah and one of the chief temples at Karnak. I am not aware that the relation has been pointed out before.

The amplitude of the temple at Denderah, dedicated to *Hathor*, is  $73^{\circ}$  N. of E. The amplitude of the temple dedicated to Mut or Maut at Karnak is  $71^{\circ}$  N. of E., which, assuming the same star to have been used, corresponds to a date (according to the height of the horizon) of *circ.* 3000 to 3500 B.C. This is therefore later than the Hathor temple of Denderah.

Now, we have it from Plutarch (*Isis and Osiris*, Parthey, cap. 56) that Isis = Maut = Hathor = Methuer, and this is sufficiently clear from the symbols of these goddesses, without his authority.

It is fundamental for the orientation theory that the cult shall follow the star. But we have here the same cult. Hathor and Maut are merely *local* names associated with local totems. Isis is a *generic* name simply, meaning an accompaniment of sun-rise, whether that light be the dawn, or a heliacally rising star, or even the moon. The generic symbol for Isis is the sun's disk and horns, which I think may not impossibly be a poetic de-

Dendérah, est vrai d'Esneh, d'Ombos, d'Assouan, de Philæ, &c. Or, si les premiers constructeurs d'un temple—ou chez nous d'une église—peuvent choisir presque à leur gré l'emplacement et par suite l'orientation, la plus convenable, il en est bien rarement de même des *reconstructeurs*. Les maisons accumulées autour du temple les gênent, d'ailleurs les habitudes du culte et de la population étaient prises; on rebâtissait le temple—comme d'ordinaire chez nous on rebâtit l'église—sur la même orientation et sur les mêmes fondations. J'ai constaté le fait à Kom-Ombo, où les débris du temple décoré par Amenhôpou I. et Thoutoum III. sont orientés exactement comme ceux du temple ptolémaïque actuel, bâti sur les ruines du précédent. Vous avez donc le droit de dire, non seulement pour Dendérah, mais pour beaucoup d'autres temples, qu'ils ont été reconstruits sur l'orientation du temple qu'ils remplaçaient, quand même cette orientation ne répondait plus à la réalité des choses.

<sup>1</sup> I have not yet reduced my own observations of this temple, but Nissen refers to previous measures, *Rheinisches Museum für Philologie*, 1885, p. 44.

lopment of the sign for sunrise. The local totem of the special warning star in use at any time or place may be anything: hippopotamus, crocodile, hawk, vulture, lion, or even some other common living thing into which the totem degraded when the supply of the original fell short.<sup>1</sup> Hence, as the number of warning stars was certainly very restricted, they, or rather the goddesses which typified them, had different names in almost every nome. Hence Egyptian mythology should be, as it is in fact, full of synonyms; each local name being liable to be brought into prominence at some time or another owing to adventitious circumstances, relating either to dynasties or the popularity of some particular shrine.

Let us concede, then, that we had the same cult. Now about the star. For Denderah we have already found  $\gamma$  Draconis. What about Thebes? As I have elsewhere pointed out, the temple at Karnak, the date of the building of which is the most certain, undoubtedly pointed to  $\gamma$  Draconis.<sup>2</sup> Its amplitude is  $62^{\circ}$  N. of E. This was in 1200 B.C. Nor is this all; as I have also shown, it forms the second of a series with the following amplitudes:—

$61^{\circ}$   
 $62^{\circ}$   
 $68^{\circ}$   
 $71^{\circ}$  } N. of E.

Now the last in this series, directed on this view to  $\gamma$  Draconis at Karnak, is precisely the temple of Maut!

So that here we have a very concrete case of the cult following the star, not only in the same place, but at different places, and we are driven to the conclusion that Hathor at Denderah and Maut at Thebes, exoterically different goddesses, were esoterically the same star  $\gamma$  Draconis.

Although it carries us still further into the region of mythology, there is more evidence to be gathered from a consideration of the old constellations. I do not think it saying too much to remark that among these the attention of the early Egyptians was almost exclusively confined to the circumpolar ones. Further, the mean latitude being, say,  $25^{\circ}$ , the circumpolar region was a restricted one,  $50^{\circ}$  in diameter, instead of over  $100^{\circ}$ , as with us. But not quite exclusively, for to them then, as to us now, the Great Bear and *Orion* were the two most prominent constellations in the heavens; for them, as for us they typified the northern and southern regions of the sky.

There can be no question that the chief ancient constellation in the north was the Great Bear, or, as it was then pictured, the Thigh (Mesxet). After this came the Hippopotamus. I had come to the conclusion that this has been replaced on our maps by part of Draco before I found that Brugsch and Parthey were of the same opinion.

The female hippopotamus typified Taurt, the wife of Set (represented by a jackal with erected tail, or hippopotamus), and one of the most ordinary forms of Hathor presents us with the horns and disk surmounting a hippopotamus. There is evidence that the star we are considering,  $\gamma$  Draconis, occupied the place of the head or the mythical headgear.

So far, then, mythology is with me; but there is a difficulty. According to the theory the cult must follow the star: this must be held to as far as possible. But suppose the precessional movement causes the initial function of a star to become inoperative, must not the cult—which, as we assume, had chiefly to do with the heralding of sunrise at one time of the year or other—change? And if the same cult is conducted in connection with another star, will not the old name probably be retained?

There is another temple of Hathor at Thebes—the

<sup>1</sup> Have we such instances of degradation in the cat replacing the lion and the black pig the hippopotamus, to give two instances?

<sup>2</sup> I refer to the Temple M of Lepsius, built by Ramses III.



temple of Dêr el-Bahari, founded or embellished by Queen Hatshepsut (c. 1600 B.C.). This temple, instead of being oriented 73° N. of E., lies 26° S. of E., it can never, therefore, have faced the star observed at Denderah.

Now, are there any possible explanations? Two have suggested themselves to me.

At Denderah the image of the goddess was taken on a certain day in the year on to the terrace, so that the light of the sun—her father Râ—might fall upon her.

Building a temple so that the sunlight might enter it once or twice a year (which could not happen in the Denderah temple in consequence of its northern outlook) would enable the aforesaid operation to be performed in the sanctuary itself. The Thebes temple on this hypothesis assured this—and at the winter solstice.

The next explanation I submit to Egyptologists with much fear and trembling. It is, briefly, that about 3200 B.C. observations of the star Sirius replaced, or were added to, those made of  $\gamma$  Draconis. Mythologically a new Isis would be born.

I base this suggestion on the following considerations:—

(1) While the Denderah Hathor was represented by the disk and horns on a hippopotamus; at Thebes, the city of the "Bull" Amen, Hathor is represented by a cow with a like headdress.

(2) Sirius, represented originally as a goddess with the two feathers of Amen standing in a boat, is now changed to a cow with the disk and horns.

(3) Hathor was the cow of the western hills of Thebes. It is in these hills that the temple Dêr el-Bahari lies, and this temple if oriented originally to Sirius would have been founded about 3000 B.C., when Sirius would have an amplitude of 26°.

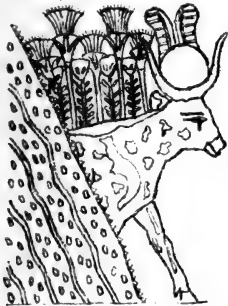

FIG. 4.—The cow Hathor appearing from the western hills of Thebes.

(4) A temple was built in later times at Denderah oriented to Sirius, and Sirius with the cow's horns and disk became the great goddess there, and when her supremacy all over Egypt became undoubted, her birth-place was declared—at Denderah—to have been Denderah.<sup>1</sup>

(5) In the month list at the Ramesseum the first month is dedicated to Sirius, the third to Hathor. This is not, however, a final argument, because local cults may have been in question.

(6) Set seems to have been a generic name applied to the northern (? circumpolar) constellations, perhaps because *set* = darkness, and these stars, being *always visible* in the night, may have in time typified it. Taurt, the hippopotamus, was the wife of Set. The Thigh was the

<sup>1</sup> Brugsch thus translates one of the inscriptions:—"Horus in weiblicher Gestalt ist die Fürstin, die Mächtige, die Thronfolgerin und Tochter eines Thronfolgers. Ein fliegender Käfer wird (sie?) geboren am Himmel in der uranfänglichen Stadt (Denderah) zur Zeit der Nacht des Kindes in seiner Wiege. Es strahlt die Sonne am Himmel in der Dämmerung, wann ihre Geburt vollbracht wird."—Brugsch, "Astron. Inscription," p. 97.

thigh of Set, &c.  $\gamma$  Draconis was associated therefore with Set, and the symbolism for Set-Hathor was the hippopotamus with horns and disk. Now, if, as is suggested, Sirius replaced  $\gamma$  Draconis, and the cow replaced the hippopotamus, the cult of Set might be expected to have declined; and as a matter of fact the decline of the worship of Set, which was generally paramount under the earlier dynasties, and even the obliteration of the emblems on the monuments, are among the best-marked cases of the kind found in the inscriptions.<sup>1</sup>

(7) The *Isis* temples of Denderah were certainly oriented to Sirius; the *Hathor* temple was as certainly *not* so oriented. And yet, in the restorations in later times (say Thotmes III.—Ptolemies), the cult has been made *Sirian*, and the references are to the star which rises at the rising of the Nile.

I do not see why the Egyptians should have hesitated to continue the same cult under a different star when they apparently quite naturally changed Orion from a form of Osiris (Sah-Osiris) and a mummy (as he was represented when the light of his stars was quenched at dawn at the rising of Sirius) to that of Sah-Horus (when in later times the constellation itself rose heliacally).

J. NORMAN LOCKYER.

### SUPERHEATED STEAM.

I HAVE noticed a curious misapprehension, even on the part of high authorities, with respect to the application of Carnot's law to an engine in which the steam is superheated after leaving the boiler. Thus, in his generally excellent work on the steam-engine,<sup>2</sup> Prof. Cotterill, after explaining that in the ordinary engine the superior temperature is that of the boiler, and the inferior temperature that of the condenser, proceeds (p. 141): "When a superheater is used, the superior temperature will of course be that of the superheater, which will not then correspond to the boiler pressure."

This statement appears to me to involve two errors, one of great importance. When the question is raised, it must surely be evident that, in consideration of the high latent heat of water, by far the greater part of the heat is received at the temperature of the boiler, and not at that of the superheater, and that, of the relatively small part received in the latter stage, the effective temperature is not that of the superheater, but rather the mean between this temperature and that of the boiler. An estimate of the possible efficiency founded upon the temperature of the superheater is thus immensely too favourable. Superheating does not seem to meet with much favour in practice; and I suppose that the advantages which might attend its judicious use would be connected rather with the prevention of cylinder condensation than with an extension of the range of temperature contemplated in Carnot's rule.

If we wish effectively to raise the superior limit of temperature in a vapour-engine, we must make the boiler hotter. In a steam-engine this means pressures that would soon become excessive. The only escape lies in the substitution for water of another and less volatile fluid. But, of liquids capable of distillation without change, it is not easy to find one suitable for the purpose. There is, however, another direction in which we may look. The volatility of water may be restrained by the addition of saline matters, such as chloride of calcium or acetate of soda. In this way the boiling temperature may be raised without encountering excessive pressures, and the possible efficiency, according to Carnot, may be increased.

The complete elaboration of this method would involve the condensation of the steam at a high tempera-

<sup>1</sup> Rawlinson, vol. i, p. 317; vol. ii, p. 347 *et seq.*

<sup>2</sup> Second edition (Spence: London, 1890).

ture by reunion with the desiccating agent, and the communication of the heat evolved to pure water boiling at nearly the same temperature, but at a much higher pressure. But it is possible that, even without a duplication of this kind, advantage might arise from the use of a restraining agent. The steam, superheated in a regular manner, would be less liable to premature condensation in the cylinder, and the possibility of obtaining a good vacuum at a higher temperature than usual might be of service where the supply of water is short, or where it is desired to effect the condensation by air.

RAYLEIGH.

#### TWO AFRICAN EXPLORERS.

WE regret to have to record the death of two of the best-known African explorers—Colonel J. A. Grant and Dr. Wilhelm Junker; the latter comparatively a young man, and the former by no means old. They belonged to two distinct types of African explorers: Grant was the true pioneer, who went out to force his way through an unknown region; Junker was the scientific student, content to spend years in one limited region in order to work out its geography, natural history, and ethnology.

The announcement of the death of Colonel James Grant, Speke's companion in the expedition for the discovery of the source of the Nile, has been received with widespread regret. The stalwart figure and genial, good-natured, boyish face of Colonel Grant has been familiar in London society and in geographical and scientific circles for more than twenty years. In African exploration and in the younger generation of African explorers he took a keen interest to the last. He was a man of chivalrous loyalty to his friends. Speke's memory he almost worshipped, and it need scarcely be said that his feelings to Burton were of a very different stamp. Mr. Stanley had no more staunch supporter than Colonel Grant. Born in the parish manse of Nairn, in Scotland, in 1827, he was educated, like so many other Scots that have distinguished themselves in the service of the country, at the Grammar School of Aberdeen, and at Marischal College. At the age of nineteen he obtained a commission in the East India Company's service, and between that and the end of the Mutiny saw much active service, and won honours for bravery and devotion to duty. It is, however, as an African explorer that he claims notice in these pages. It will be remembered that in 1857 the only great lakes, of which we knew anything, in the map of Africa were Chad and Nyassa, the latter then quite recently plotted for certain by Livingstone. But rumours of other lakes had been filtering down to the coast for years. In 1857, Burton and Speke started from Zanzibar in search of "the Great Lake," as it was vaguely called; and, after a painful march of eight months, found Tanganyika, the first discovered of those great sheets of water which form so marked a feature of the centre of the continent. On the return journey, Speke took a run north, to find another great lake said to exist in that direction. He reached the southern shore of Lake Ukerewe, which has since become so well known as Victoria Nyanza. Though Speke only caught a glimpse of the southern waters of the lake, and had no adequate idea of its amplitude, he conjectured rightly that it must be the source of the Nile. Into the unhappy quarrel of Speke and Burton it is unnecessary to enter. But Speke, and not Burton, was selected by the Royal Geographical Society, in 1860, to lead an Expedition to the lake for the purpose of confirming his conjecture. This Expedition Government subsidized to the amount of £2500. Captain Grant, as he was then, was chosen to accompany Speke. The latter was, no doubt, the leader

of the Expedition; but Grant, though he suffered much, and had to be carried a great part of the way, did much to render the expedition of scientific value. The unknown countries to the west and north-west of Victoria Nyanza were explored, though the contour of the lake was very inadequately laid down. Uganda was reached in 1862, and in July of that year the Nile was seen issuing full-born from the lake, and dancing its way north-west over Ripon falls. The two travellers followed the river for 120 miles, but were compelled to quit it, and so missed the discovery of its connection with the Albert Nyanza. They came upon it again 70 miles further down, and reached Gondokoro in February 1863, where they were met and succoured by Samuel Baker.

As might have been expected, the discoverers of the Nile sources received a great ovation on their arrival in England. Grant, like Speke, received the gold medal of the Royal Geographical Society, and was made a C.B. In 1864, under the title of "A Walk across Africa," he published a narrative of the expedition. In 1872 he published "A Summary of the Speke and Grant Expedition" in the *Journal of the Royal Geographical Society*. Colonel Grant was a careful observer, and his "Walk across Africa" abounds in interesting facts and suggestions on country and people, especially on the latter.

It was he who did the greater part of the scientific work on the Nile Expedition, and among other things he made a considerable collection of dried plants now in the Kew Herbarium. A rough list of these formed an appendix to Speke's "Journal of the Discovery of the Source of the Nile"; and most of the illustrations of this work were from drawings made by Grant. The publication of the first volume of Prof. D. Oliver's "Flora of Tropical Africa" fired Grant with the desire to have a special volume prepared on the flora and fauna of the Expedition. The result was that the whole of the twenty-ninth volume of the *Transactions of the Linnean Society* was devoted to the flora, and it is one of the most interesting of the series. The purely botanical part was contributed by Prof. Oliver and Mr. J. G. Baker; and the 136 plates (prepared at Colonel Grant's expense) illustrating the new or otherwise specially interesting plants, are some of the best work of the late W. H. Fitch.

In 1871 Grant was elected a Fellow of the Linnean Society, and in 1873 of the Royal Society; and many other distinctions were conferred upon him, including a Companionship of the Star of India for his military services in India and Abyssinia.

Dr. Johann Wilhelm Junker was a different type of explorer. He was born in Moscow, of German parents, on April 6, 1840. He spent his boyhood in Göttingen, attended the German Gymnasium at St. Petersburg, and studied medicine at Göttingen, Berlin, and Prague. After a visit to Iceland, Junker went to Tunis in 1874, and to Egypt in 1875. In that year he began those explorations which, with one or two interruptions, he carried on continuously for twelve years. He visited Lake Mareotis, the Natrôn Lakes, and the Fayum. In 1876 he went from Suakin, through the Khor Baraka, to Kassala and Khartum; he explored the lower Sobat, and made successive journeys among the western tributaries of the Nile. In 1876 he proceeded as far westwards as Makaraka, and in 1877 crossed the Tangi River and visited the Wau, thus overlapping the route of Schweinfurth (1869-70). Indeed, Junker, during his many years' journeying, did a great deal to supplement the work of his distinguished predecessor. After a brief visit to Europe (1878), Junker was back in Africa in 1879, this time accompanied by a photographer (Bohndorff), who also lent a helping hand in preparing the numerous natural history collections. He accompanied several of the expeditions sent out by the Egyptian authorities from Khartum. But Junker often wandered almost alone, with very few native companions, and as a

rule he was everywhere well received. To him we are indebted for much of our information on the Monbutts and their country, the A-Sandeh and the various other tribes that inhabit the wide region watered by the Western Nile tributaries and some of the northern feeders of the Congo. Indeed, much of Junker's work lay in that extremely interesting country which forms the water-parting between the basin of the Nile and the Congo, and his hydrographical observations form some of the most important results of his many years' travels. To him may be said to be due the first steps in the solution of what was long known as the Wellé problem. The Wellé, which Schweinfurth came upon near its sources, was, even up to 1886, conjectured by many to be the upper course of the Sharé, which runs into Lake Chad. Junker struck the river at various places, one as far west as 22° 40' E.; but it was not until Grenfell and Van Gèle followed the Mobangi up from the Congo that the Wellé was proved to be one of the chief northern feeders of the Congo. But this is only one of many services rendered by Junker to the scientific geography of Africa. His investigations into the ethnology of the whole of this intensely interesting region are of the first importance, and his collections both in ethnology and in natural history now form some of the most prominent exhibits in the great Museum of St. Petersburg. Junker was an admirable specimen of the scientific explorer, and his twelve years' researches in the Soudan entitle him to be classed with Schweinfurth and Nachtigal, Wallace and Bates. Junker was in the heart of the Soudan when the Mahdist revolt reached a crisis. He had the greatest difficulty in escaping, and it was only after long detention that he reached Europe *via* Lake Victoria, Zanzibar, and Egypt. He made many friends in London when he came here to receive the gold medal of the Royal Geographical Society, which he well deserved.

#### NOTES.

MRS. ADAMS wishes us to say that she would be very grateful if former friends and scientific correspondents of the late Prof. J. C. Adams would be so kind as to send to her care any of his letters still in their possession. Their doing so would much assist in the preparation of a memoir. All letters so intrusted will be carefully returned.

THE Electrical Committee of the Royal Commission for the Chicago Exhibition are anxious that the electrical department of the Exhibition should contain a good representation from this country. They have accordingly issued a circular letter on the subject, and it may be hoped that this will receive the careful attention of all who are in a position to facilitate the Committee's arrangements. The Committee especially desire that the Exhibition may display the very large share which English electricians have had in the development of electrical science and its practical applications. It is hoped that the fine collection of historical apparatus in the possession of the Post Office may be shown, and this will be supplemented by contributions which will be sought from many other sources. Although practical electric lighting has made greater progress in America than in this country, the Committee think there is much that England can show electricians on the other side of the Atlantic; and firms who devote special attention to the domestic uses of electricity and its artistic application are reminded that it may be to their interest to send to the Exhibition good specimens of their work. There will also be excellent opportunities for the manufacturers of electric railway signals, and for electro-metallurgists.

ON January 1, no fewer than 2082 applications for space at the Chicago Exhibition had been received from intending exhibitors in the United States alone. The number at the Philadelphia Centennial on the corresponding date was 864.

Many applications have come from foreign countries, and it is expected that the exhibitors will be more numerous than at any previous "World's Fair." The allotment of space is to be made about June. The reception of exhibits will begin on November 1 next, and continue until April 10, 1893.

WE regret to have to record the death of Mr. H. W. Bates, F.R.S. He was sixty-seven years of age. Of his well-known book, "The Naturalist on the River Amazons," Darwin said that it was "the best work of natural history travels ever published in England." His "Contributions to an Insect Fauna of the Amazons Valley," printed in the Transactions of the Linnean Society, were described by the same high authority as "one of the most remarkable and admirable papers he had ever read in his life." Mr. Bates is widely known as the discoverer of the principle of mimicry in the animal world. For twenty-seven years he was the acting secretary of the Royal Geographical Society.

WE have received an intimation of the death of Dr. Pieter Willem Korthals, at the advanced age of eighty-four years. He was for many years in the Dutch East Indian Service, and published a considerable number of papers on the botany of Sumatra, Borneo, and Java, the most noteworthy of which form a folio volume entitled "Verhandelingen over de Natuurlijke Geschiedenis der Nederlandsche overzeesche Bezittingen," edited by C. J. Temminck, 1839-42. This work contains seventy coloured plates of excellent execution. Dr. Korthals's first botanical paper appeared in 1830, and dealt with the genus *Nepenthes*; and his last, so far as we are aware, appeared in 1854. He was a Knight of the Dutch Order of the Lion.

THE Council of the Royal Society of Edinburgh have awarded the Keith Prize for 1889-91 to Mr. R. T. Omond, for his contributions to meteorological science; and the Macdougall-Brisbane Prize for 1888-90 to Dr. Ludwig Becker, for his paper on "The Solar Spectrum at Medium and Low Altitudes."

THE Grand Gold Medal of the Paris Geographical Society has been awarded to M. Reclus. A gold medal has also been awarded to the Prince of Monaco for his researches on marine currents.

SIR JOHN COODE, Past-President of the Institution of Civil Engineers, was last Friday elected by the Committee of the Athenæum Club a member, under Rule II., which provides for the annual introduction of a certain number of persons of distinguished eminence in science, literature, or the arts, or for public services.

THE third Congress on anthropology in relation to crime will be held at Brussels from August 23 to September 3 next.

ON Monday Lord Cowper called attention in the House of Lords to the subject of technical instruction, and to "the difficulties in which County Councils were placed by not knowing whether or not they could rely upon a permanent annual Government grant for its promotion." Lord Cranbrook, in the course of his reply, said he did not believe any Government would repeal the Act in accordance with which the Councils had received the money which was being devoted to technical education. So far as the present Government were concerned, they had not the smallest intention of repealing the Act or of taking the money for any other purpose.

At a Conference on technical education, held in Edinburgh on October 29, 1891, a general committee was appointed to consider the subject. This general committee in turn appointed a sub-committee to report on the amendments necessary in the laws relating to technical education in Scotland. The report of the sub-committee has now been issued; and appended to it is an official statement to the effect that the general committee,

while approving of the suggestions made in the report, is of opinion that the Government ought to take an early opportunity of dealing with the question of technical and secondary education in a comprehensive measure, and that, for the efficient supervision of technical education, wider administration areas than the parish are required.

THE ceremonies in connection with the tercentenary celebration of Trinity College, Dublin, will begin on the morning of July 5, and conclude on the evening of July 8 next. Invitations were sent to most of the Universities and learned Societies in Europe, America, and the colonies, during last term; and replies have been received from many sending representatives, including Aberdeen, Athens, Bern, Cambridge, Christiania, Edinburgh, Erlangen, Giessen, Heidelberg, Johns Hopkins, Lausanne, Leyden, Madras, Naples, Smithsonian Institute, Sydney, Toronto, &c., and acceptances are daily arriving. A large number of acceptances have also been received to the numerous personal invitations. Among the men of science who intend to be present are Sir F. Bramwell, Geo. Darwin, Thiselton Dyer, J. Evans, D. Ferrier, M. Foster, Sir A. Geikie, H. Hertz, J. W. Judd, Ray Lankester, Sir J. Lister, Sir J. Lubbock, Baron Nordenskiöld, Sir J. Paget, Lord Rayleigh, Sir G. Stokes, and Sir W. Turner. While the programme of the celebration has not yet been finally approved of, it will probably include the following:—On the Tuesday morning there will be a reception by the Provost of Trinity College of all the invited guests; then a short full choral service in St. Patrick's Cathedral; in the afternoon a garden party; and in the evening a civic ball. On Wednesday morning there will be the presentation of addresses of congratulation from the various Universities, and in the evening a grand banquet, at which it is expected that over five hundred guests or members of the University will be present. On Thursday morning there will be a special Commencements for the conferring of a number of honorary degrees; after which there will be an adjournment from the Senate House to the College Park to witness the College races, held under the auspices of the College Athletic Club; in the evening there will be a special amateur dramatic performance. On the Friday morning there will be a gathering of the students to hear short addresses from some of the distinguished visitors; in the afternoon, a concert given by the members of the University Choral Society; and in the evening, the students' ball. Numerous committees are daily engaged working out the multifarious details. One of these has been charged with the superintendence of the publication of an illustrated volume, which is to give the past and present history of the College, the publication of which volume has been undertaken by the firm of Messrs. Marcus Ward and Co.

ON April 1, 1841, Sir William Hooker began his duties as Director of Kew. In the year 1891, therefore, the establishment might have celebrated its jubilee as a national institution, and it seemed to Mr. Thiselton Dyer that he might fitly mark the occasion by giving in the *Kew Bulletin* some account of the origin and development of the Royal Gardens as a place of botanical study. This intention he has now partly carried out, the December number of the *Bulletin*—which has just been issued—being entirely devoted to the subject. The narrative is one of great interest, and has evidently cost the author much hard work, as scarcely any authentic records exist of the period before 1840, when the Gardens were a purely private possession of the Crown. He has thus had "to fall back on local traditions, on local histories, the statements in which are often confusing and inaccurate, and on such scattered notices as could be gathered from contemporary literature." In the present instalment, the story is brought down to the year 1841. The history of the last half-century will be given in another number.

IN pursuance of his botanical expedition to Persia, Herr J. Bornmüller arrived at Batoum on December 24. Thence he intended proceeding to Teheran by way of Tiflis and Baku, and then, as rapidly as possible, to the south of Persia. The expedition is intended to extend over two years, and Herr Bornmüller does not intend to collect more than from fifteen to twenty sets of the plants obtained. Orders for sets should be sent to Herr R. Huter, Sterzing, Tirol.

MR. JAMES BRITTEN and MR. G. S. BOULGER intend to issue (to subscribers) in June next, their "Biographical Index of British and Irish Botanists," reprinted, with additions and corrections, from the *Journal of Botany*, and brought down to the end of 1891. As the promises of support at present received will not cover expenses, they will be glad to receive the names of additional subscribers, addressed to the care of the publishers of the *Journal of Botany*.

ACCORDING to a telegram from New York, one of the finest displays of the aurora borealis ever known in that latitude was observed on the evening of February 13. The phenomenon stretched over a great belt of territory from Iowa to the Atlantic. A peculiar effect was produced on the telegraph system, and for intervals of three or four minutes at a time the wires were so surcharged with atmospheric electricity that between New York and Albany it was possible to send messages without the aid of the regular batteries. The current, however, was intermittent, and the effect unsatisfactory. For nearly two hours ordinary business could not be transacted with any degree of exactness. The aurora seemed to occupy the whole of the northern heavens, and was beautifully marked, the colouring being clear and distinct. People at first feared that a great fire was raging.

DR. A. WOIKOFF, of St. Petersburg, who is engaged on an investigation into the cause of the famine in Russia, writes to the *Meteorologische Zeitschrift* that it is chiefly due to drought from August to October 1890, which injured the winter crops; to partial and insufficient snow, which melted early in the spring, and was followed by frost in April; and lastly to droughts and hot winds from May to July 1891. In the southern portion of the Government of Samara the prospects up to June 10 were excellent, but the harvest was destroyed by two days of hot winds, on June 14 and 15. And in the southern central provinces also, where the winter crops had greatly suffered, a moderate harvest was hoped for after the middle of July, but four hot days, from July 13 to 16, quite destroyed the crops.

THE Journal of the Scottish Meteorological Society (third series, No. 8) contains a very interesting paper on silver thaw at Ben Nevis Observatory, by R. C. Mossman. The phenomenon is somewhat common at that Observatory, and occurs during an inversion of the ordinary temperature conditions, the temperature being considerably lower at the surface than at higher altitudes, causing the rain to congeal as it falls. In the six years 1885-90, 198 cases of silver thaw were observed, with a mean duration of  $4\frac{1}{2}$  hours in each case, and they nearly all occurred between November and March, during times of perfectly developed cyclones and anticyclones. An examination of the weather charts of the Meteorological Office showed that for the 198 days on which the phenomenon was observed, the distribution of pressure was cyclonic on 137 days, and anticyclonic on 61 days. In anticyclonic conditions there was a cyclonic area central off the north-west coast of Norway, while the centre of the anticyclone was over the south of the British Isles. In cyclonic cases, an anticyclone lay to the south, over the Iberian Peninsula. The lowest temperature at which the phenomenon took place was 18°, and was rarely below 27°. Fully 90 per cent. of the cases occurred when the thermometer was between 28° and 31°·9, so that the

greater number of cases occurred just before a thaw. The most common type of cloud which preceded both cyclonic and anticyclonic cases of silver thaw was cirro-cumulus, frequently accompanied by cirrus and cirro-stratus; and the changes showed that the higher strata of the atmosphere came first under the influence of the moist current, which took from three to eight hours to descend to the height at which cumulo-stratus forms. An examination of a series of storm charts prepared by Dr. Bachan disclosed the somewhat remarkable fact that 73 per cent. of the cyclonic, and 63 per cent. of the anticyclonic cases of silver thaw on Ben Nevis were followed or preceded by gales on our northern and north-western coasts; and it would appear from the wind conditions that the barometric gradient at the height of Ben Nevis (4407 feet) must be totally different from what obtained at sea-level during the occurrence of silver thaw on the hill-top. Many of our readers will remember the remarkable case of silver thaw which occurred in London last Christmas Day.

THERE has been much talk in Germany about Dr. Peters's discovery of saltpetre in the Kilima Njaro district. This discovery accords with statements which were already well known. Dr. Fischer, after an examination of the Donjongai volcano, reported that in the neighbourhood of the crater there were a series of curiously shaped veins of a white substance which he took to be either saltpetre or soda. In 1879, Herr Jarler asserted that large quantities of sulphur would probably be found in the crater. The Berlin correspondent of the *Times*, by whom these facts are noted, adds that not far from the volcano there lie great swamps from which soda is obtained. It is expected that an expedition for the exploration of the district will soon be sent out by the German East Africa Company.

PROF. A. GIARD calls the attention of naturalists to a new case of mimicry between two very different insects (the one Hymenopterous, the other Dipterous)—*Athalia annulata* and *Beris vallata*. When both insects are quiet, the resemblance of colour and patterns is perfect, and as the *Athalia*, like most Tenthredine, is protected against birds and other foes by its unpleasant smell, it is probable that the resemblance is of considerable service to *Beris*. M. Giard also refers to the larva of *Allantus tricoloratus* which is commonly found on the leaves of plants, vividly coloured, and quite conspicuous, but resembling in form and colour birds' droppings, as is the case with a spider described by H. O. Forbes.

THE number of persons who approve of cremation seems to be steadily increasing. From the Report of the Cremation Society of England for 1891, we learn that in 1885, the first year the crematorium at Woking was used, only three bodies were sent there; in 1886 the number was 10; in 1887, 13; in 1888, 28; in 1889, 46; in 1890, 54; and during the past year, 99. Crematoria are being built in various parts of the country. At Manchester a crematorium is in course of erection, and will, it is thought, be completed and opened for use during the coming spring. A company has also been formed, and is making rapid progress, with the same object at Liverpool; and the City of London Commission of Sewers is taking steps to obtain powers to erect a crematorium at their cemetery at Ilford. The Cremation Society at Darlington, and other associations, are moving in the same direction.

A SMALL axe of nephrite, found at Ohlau, in Silesia, and now in the Roman-German Museum at Mainz, has lately been carefully examined by Dr. O. Schoetensack, with a view to the discovery of the source from which the material must have been obtained. From a thorough determination of its specific gravity, microscopic structure, and chemical composition, Dr. Schoetensack concludes that the nephrite is exactly the same as

a mineral which has been found by Dr. Traube near Jordansmühl, in Silesia. There is no reason, therefore, why the axe should not be pronounced to be of Silesian origin. This is the only prehistoric object of nephrite, found in Europe, the source of which has been definitely decided.

PROBABLY few authorities responsible for the making and maintenance of roads are aware that one of the things against which they should be on their guard is the use of rotten flints for macadamising purposes. Mr. C. Carus-Wilson has been giving some attention to this subject at Bournemouth, and, in a letter to a local journal, states the conclusions at which he has arrived. He was led to consider the matter by the abnormal quantity of slush on the surface of Poole Road. This he attributes to the fact that the road has again and again been mended with rotten flints, by which he means flints that have become decomposed to such an extent that there is very little true flint left. These flints are surrounded by a thick zone of soft white material. This is rapidly removed from the flinty nucleus by the grinding and pressure to which it is subjected; while the true flinty nucleus, being thus denuded of its outer covering, becomes too small to bear much crushing weight, so that it quickly breaks up, and forms a fine flint sand. Mr. Carus-Wilson has found by repeated microscopic analysis that the Poole Road mud is formed principally of these two substances.

THE Journal of the Society of Arts prints this week an interesting lecture on burning oils for lighthouses and lightships, by E. Price Edwards. It was delivered at a meeting of the Society on February 10. After the lecture Sir Lyon Playfair, who was in the chair, said it was quite clear that mineral oils must in time beat the vegetable oils, on account of their chemical composition, the ingredients in the latter not being all combustible, but consisting of fatty acids and glycerine. Mineral oils, on the other hand, were nearly of the same composition as olefant gas, the illuminating constituent of coal gas, with the addition of a little more hydrogen. They were therefore sure to win in the end; it was merely a question of manufacturing them safely.

AT the meeting of the Field Naturalists' Club of Victoria on December 14 last, Mr. A. J. Campbell read a paper on a nest and egg of a bird of paradise (*Ptiloris victoriae*). Eastern Australia possesses a genus (three species) of these beautiful birds, but they are very seldom seen. The nest was found on November 19, by Mr. Dudley Le Souëf and Mr. H. Barnard during a visit to the North Barnard Islands, about forty miles off the coast from Cardwell, Queensland. They watched the hen bird for some time, and saw her fly into the crown of a Pandanus tree growing close to the open beach. Although they could not distinguish the nest itself, they could see the head of the bird as she sat on it. The nest was about 10 feet from the ground, and the bird sat quietly, although they were camped about 5 feet away from the tree. There was a single egg, the incubation of which was probably about seven days old. The nest was somewhat loosely constructed of broad dead leaves and green branchlets of climbing plants and fibrous material. Inside were two large concave-shaped dead leaves underneath pieces of dry tendrils which formed a springy lining for the egg or young to rest upon. The following is the measurement in centimetres: over all, 19 broad by 9 deep; egg cavity, 9 across the mouth by 4 deep.

DOVE's observation that when a tuning-fork of proper pitch is held to each ear beats can be heard, where there is no possibility of interference of the sound-waves in the air, is confirmed by Dr. W. Scripture (*Wundt's Philosophische Studien*), who further gives experimental ground for rejecting the hypothesis of transference of the sound through the bones of the head of

the Eustachian tubes. Difference-tones, on the other hand, seem to be only perceptible when the tones of both forks affect the same ear. The same number of the *Studien* contains the first instalment of an elaborate article by Dr. J. Merkel upon the psychophysical error-methods.

If we may judge from the progress of the Photographic Society of India, photography is rapidly becoming more popular among Anglo-Indians. In January 1891, there were 277 members on the Society's books; now there are over 310.

The *Oesterreichische Botanische Zeitschrift* for February contains a very full account of the results of Porta and Rigo's visit to Spain in 1891, and of the species gathered by them on their journey.

We have received Parts 10 and 11 of the "Illustrations of the Flora of Japan," published at Tokyo. The drawings continue excellent; the diagnoses are unfortunately in Japanese.

MESSERS. DULAU AND CO. have issued a catalogue of botanical works which they offer for sale. It contains the titles of about 3000 writings relating to geographical botany.

THE "Electrical Trades Directory," issued by Mr. George Tucker on behalf of the *Electrician*, has made its tenth annual appearance; and no effort has been spared to bring it up to date. The biographical division of the work contains sketches of the careers of 260 men who are well known in the electrical world. These sketches have all been revised by the subjects of them. No fewer than 28 of these notices are accompanied by portraits, among which is a portrait of Prof. Ayrton from a specially engraved steel plate.

The Royal University of Ireland has issued its Calendar for the year 1892.

An experiment, illustrating the remarkable power possessed by palladium of occluding hydrogen, is described by Prof. Wilm, of St. Petersburg, in the current number of the *Berichte* of the German Chemical Society. The experiment is so simple, and requires so short a time to exhibit, that it would appear to be eminently suitable for lecture demonstration. The metallic palladium is employed in the finely divided state obtained by heating the easily prepared yellow crystals of the compound  $\text{PdCl}_2 \cdot 2\text{NH}_3$ , first in the open air, and subsequently for a short time in an atmosphere of hydrogen. A small quantity, about four grams in weight, of the palladium so obtained is placed in a bulb blown at the bend of a U-shaped tube. The extremity of one limb of the U-tube is bent round at right angles, and connected with a wash-bottle containing sulphuric acid, which in its turn is connected with a Kipp's apparatus generating hydrogen from zinc and dilute sulphuric acid. The wash-bottle serves not only to dry the hydrogen, but also to indicate the speed of the current of gas. The extremity of the other limb of the U-tube is narrowed to a capillary, and terminates with a tightly-fitting stopcock and jet. In commencing the experiment, the hydrogen current is started, and then, first the metal, and afterwards the whole U-tube, is carefully heated with a Bunsen flame in order to remove the moisture formed by the action of the hydrogen, under the influence of the palladium, upon the oxygen of the air contained in the apparatus. When all the air and moisture are thus driven out of the apparatus, an attempt may be made to ignite the issuing hydrogen at the jet above the open stopcock. It will be found, however, that even while the metal is hot and the stream of hydrogen very rapid, a constantly burning flame cannot be maintained at the jet with the stopcock fully open; instead, a series of somewhat explosive ignitions and sudden extinctions occurs. It is only when the stopcock is turned so as to reduce the exit of the gas to a minimum that a constantly

burning jet can be obtained, the hydrogen in contact with the palladium being then subjected to a certain amount of compression. The palladium is now heated a little more strongly, just above bright redness, when it is no longer capable of occluding hydrogen, and then the lamp is withdrawn, and after a few seconds the stopcock closed. The occlusion is then demonstrated in a most striking manner, for the stream of hydrogen continues to bubble through the sulphuric acid bottle and into the U-tube for several minutes with its original rapidity, although all exit is prevented by the closing of the stopcock. At length, however, the occlusion diminishes, and the stream of hydrogen gradually becomes slower and slower, until it entirely ceases, the palladium having regained the temperature of the room, and become saturated with hydrogen at this temperature. If now the stopcock is opened, and the metal again heated, upon applying a flame to the jet, the issuing hydrogen evolved from the palladium takes fire, and burns with a tall flame which remains constant for some minutes, then, as the hydrogen stored in the palladium becomes exhausted, diminishes in size, and finally disappears. The moment the flame is removed occlusion instantly commences again, and the experiment may be repeated any number of times with undiminished effect.

THE additions to the Zoological Society's Gardens during the past week include a Herring Gull (*Larus argentatus*), six Common Gulls (*Larus canus*), five Black-headed Gulls (*Larus ridibundus*), British, presented by Mr. T. A. Cotton, F.Z.S.; a Roseate Cockatoo (*Cacatua roseicapilla*) from Australia, a Grey Parrot (*Psittacus erithacus*) from West Africa, presented by Mrs. Hennah; a Red-winged Parrakeet (*Aprosmictus erythropterus*) from Australia, presented by Lieut.-Colonel R. J. H. Parker, R.E.; and a Cape Dove (*Ena capensis*) from South Africa, presented by the Rev. George Smith.

#### OUR ASTRONOMICAL COLUMN.

PHOTOGRAPHIC MAGNITUDES OF STARS.—The Astronomer-Royal communicated a paper "On the Relation between Diameter of Image, Duration of Exposure, and Brightness of Objects in Photographs of Stars taken at the Royal Observatory, Greenwich," to the Royal Astronomical Society in January. First, with regard to the relation between the diameter of the image of a star on the photographic plate and the time of exposure. Measures of a large number of stars have led to the development of the following empirical formula for the same star with different exposures—

$$\sqrt{d} = 1.03 \log t + \text{const.},$$

where  $d$  is the diameter of a stellar image in seconds of arc, and  $t$  the exposure in seconds of time, the magnitude,  $m$ , being expressed on Pogson's scale. This relation represents the observations through a range of eight magnitudes, with a mean apparent error of less than one-twentieth of a magnitude. By using the measures from which the above formula was deduced, and photometric determinations of magnitude made at Bonn and Oxford, data were obtained for determining whether there was a constant relation between duration of exposure and brightness of star photographed, whether, in fact, for equal diameters of images—

$$\text{Exposure} \times \text{brightness} = \text{const.}$$

The relation found from the comparison was

$$0.4 \times m = 0.97 \log t + \text{const.}$$

This agrees very well with

$$0.4 \times m = \log t + \text{const.},$$

in which 0.4 is the logarithm of the number expressing the magnitude-ratio. By combining the two relations developed, it follows that, for the same exposure—

$$\text{Magnitude of star} = \text{const.} - 2.43 \times \sqrt{\text{diameter}}.$$

And finally the three formulæ are expressed by the following:—

$$m = 2.5(\log t - 0.97 \sqrt{d}) + \text{const.},$$

connecting magnitude, diameter of image, and time of exposure.

THE ZODIACAL LIGHT.—“The Zodiacal Light as related to the Terrestrial Temperature Variations” is the subject of a reprint from the *American Meteorological Journal* for November 1891, recently received from Mr. O. T. Sherman. In it the author endeavours to show that, when the temperature of the whole earth is considered, “the principal cause of variation is the difference in the sum of the local densities of the zodiacal light-forming matter which lies between us and the sun.” Curves have been constructed to indicate five-yearly means of temperature variation from 1790 to 1884, five-yearly means for the zodiacal light, and the yearly auroral numbers for Europe south of the polar circle; but there are not sufficient data to permit the deduction of any very definite conclusion from them.

#### THE ANCIENT TOMBS AND BURIAL MOUNDS OF JAPAN.

AT a recent meeting of the China branch of the Royal Asiatic Society at Shanghai, Prof. Hitchcock, of the Smithsonian Institute, read a paper on the ancient tombs and burial mounds of Japan, in the course of which he said that, while the form and structure of the Japanese mounds were now known, thanks to the as yet unpublished researches of his companion in many journeys in Japan, Mr. W. Gowland, their early origin was yet to be traced. It was surmised that a few at least of the Japanese burial customs were derived from China. In the course of his own travels in the north of China he had failed to discover any indications of the existence of mounds like those in Japan; but he still expected to hear of them from some experienced traveller in the interior of that vast empire. Referring to the origin of the tombs, the lecturer said the first Emperor, who lived in the seventh century B.C., is supposed to be buried in Yamato, and the tombs of his successors are pointed out by the Imperial Household Department. The identity of the sepulchres may be questioned, but it is a fact that we can distinguish consecutive modifications of form apparently corresponding to successive periods of time.

Several distinct methods of interment have prevailed at different periods in Japan. They may be conveniently distinguished as follows: (1) burial in artificial rock caves; (2) in simple earth mounds, with or without coffins; (3) in rock chambers, or dolmens; (4) in double or Imperial mounds. The lecturer then proceeded to illustrate the appearance of these different kinds of mounds by the aid of photograph slides thrown on to a screen. He showed that the double mounds were invariably protected by a wide and deep moat, sometimes by two, and consisted of two distinct mounds with a depression between them. One of these double mounds, near Sakai, according to Japanese reckoning dates from about the fourth century. The height is about 100 feet, and the circuit of the base 1526 yards. The Emperor Kei Tai, who is reported to have lived in the sixth century, was one of the last emperors known to have been buried in a double mound. Some mounds have terraced sides, and this form is said to date from about the seventh century. Large quantities of clay cylinders were used for the purpose of preserving the terraces against the effects of the weather. When the covering of earth is removed, it is found that the stone chamber beneath, which contained the coffin, opens through passages often 40 feet and sometimes 60 feet long. The earth has in many cases been washed away from the mounds, exposing the rocks which are piled over the central chamber. According to a Japanese authority, in all the sepulchres the first order of performing the burials was the piling up of the earthen mound, leaving an underground tunnel leading from the outside to the very centre of the mound. This mound completed, the coffin, usually carved and made of stone, in which the corpse was placed, and sealed, was then introduced through the tunnel and placed in the centre of the mound, and the tunnel was then filled up with stones. The lecturer, however, said the coffins were not always introduced through the galleries, and the tunnels were certainly not filled up with stones, although their ends were probably closed with stones. He inferred from his own observations that the chambers were frequently, if not usually, built round the coffins. Stone and clay coffins had been found together in one cave, showing them to have been contemporaneous.

After showing a number of photographs of the pottery discovered in the mounds, he drew attention to a number of small clay figures representing human beings. He said it was a very ancient custom in Japan to bury the retainers of a prince standing upright around his grave. Like many other customs, this also came from China. In the time of the Japanese Emperor

Suinin (97–30 B.C.), his younger brother died, and they buried all who had been in his immediate service around his tomb alive. “For many days they died not, but wept and cried aloud. At last they died. Dogs and crows assembled and ate them. The Emperor’s compassion was aroused, and he desired to change the custom. When the Empress Hibatsuhime-no-Mikoto died, the Mikado inquired of his officers, saying: ‘We know that the practice of following the dead is not good. What shall be done?’ Nomi-no-Sukune then said: ‘It is not good to bury living men standing, at the sepulchre of a prince, and this cannot be handed down to posterity.’ He then proposed to make clay figures of men and horses, and to bury them as substitutes. The Mikado was well pleased with the plan, and ordered that henceforth the old custom should not be followed, but that clay images should be set round the sepulchre instead.” Even as late as the year 646 an edict was published, forbidding the burial of living persons, and also the burial of “gold, silver brocade, diaper, or any kind of variegated thing.” From this it might be inferred that the old custom of living burial was kept up, to some extent, even to the seventh century. The edict reads: “Let there be complete cessation of all such ancient practices as strangling oneself to follow the dead, or strangling others to make them follow the dead, or killing the dead man’s horse, or burying treasures in the tomb for the dead man’s sake, or cutting the hair, or stabbing the thigh, or waiting for the dead man’s sake.” The figures of clay thus introduced as substitutes for human sacrifices, and also to take the place of horses, are known as *tsuchi ningyo*. Specimens of them are now very rare, and this fact leads to the supposition that the figures were not buried, but left exposed on the surface of the ground.

In the discussion which followed, Dr. Edkins pointed out the resemblance which existed between the stone relics found in Japan and China and in Europe, as indicating the existence of communication between distant lands in those days. It was also very interesting to note that, in the very earliest ages, men had been possessed with the idea of a future life for the soul.

#### UNIVERSITY AND EDUCATIONAL INTELLIGENCE.

CAMBRIDGE.—E. W. Hobson, M.A., Fellow and Lecturer of Christ’s College, late Deputy Lowndean Professor, has been approved for the degree of Doctor in Science.

A decision on the subject of appointing lecturers in agricultural science will be taken by the Senate on February 25.

A meeting for the purpose of considering the propriety of erecting in Westminster Abbey a memorial to Prof. Adams has been summoned by the Master of St. John’s, and will be held in the Combination room of that College on Saturday, February 20, at 3.30 p.m.

ST. ANDREWS.—At a meeting on Saturday, the 13th inst., of the Senatus Academicus of St. Andrews University, consisting of the Principals and Professors of the United College and St. Mary’s College, St. Andrews, and University College, Dundee, it was unanimously resolved to confer the honorary degree of LL.D. upon Prof. Michael Foster, F.R.S., and Dr. Hugo Müller, F.R.S. The conferring of the degrees will take place in April.

#### SOCIETIES AND ACADEMIES.

##### LONDON.

Royal Society, January 28.—“On certain Ternary Alloys. Part V. Determination of various Critical Curves, and their Tie-lines and Limiting Points.” By C. R. Alder Wright, D.Sc., F.R.S., Lecturer on Chemistry and Physics in St. Mary’s Hospital Medical School.

The author describes a number of “critical curves” obtained in accordance with the triangular system of representation proposed by Sir G. G. Stokes, whereby the composition of a given ternary mixture is represented by the position of the centre of gravity of three weights placed at the respective corners of an equilateral triangle, and respectively in the proportions of the three components of the mixture. With certain pairs of metals, e.g. lead and zinc, each will only dissolve the other to a limited extent when molten, so that a mixture of the two separates into two binary alloys, one containing chiefly lead with a little zinc, the other mainly zinc with a little lead, the exact proportion depending on the temperature of the mass. If a third metal, e.g. tin, be added to the mixture, such that this third, or

"solvent," metal will mix in all proportions with either of the other "immiscible metals" separately, the ternary mixture produced either forms a "real" ternary alloy, not separating into two different mixtures on standing (molten), or else an "ideal" alloy incapable of existing, and immediately separating into two different ternary mixtures; e.g. one chiefly containing lead with some of the tin and a little zinc, the other mainly consisting of zinc with the rest of the tin and a little lead. The two points representing these two mixtures lie on opposite sides of the point indicating the total mass of the three metals originally used, this third point lying somewhere on the straight line connecting the other two "conjugate points," or "tie-line." By employing a series of mixtures containing gradually increasing proportions of the third "solvent" metal, two branches of a curve are gradually traced out representing the respective loci of the pairs of conjugate points; these two branches of the "critical curve" tend to meet at some point, termed the "limiting point," where the tie-lines vanish.

A large number of experiments were made to determine the conditions necessary to obtain the nearest possible approximations to the positions of truly conjugate pairs of points; former experiments having indicated that the compositions of the two alloys formed might be influenced by the relative proportions of the two immiscible metals, in such fashion that points slightly varying in position along one branch might be obtained as conjugates to a given point on the other branch under different conditions. It was found that such variations entirely disappeared with thorough admixture, which is more readily effected when the proportions used are such as to give rise to approximately equal quantities of the two alloys than when they are such that one alloy is formed to a much larger extent than the other. Observations with non-metallic analogous fluids (chloroform, water, glacial acetic acid) always gave sharply concordant values, thorough intermixture (by shaking vigorously in a stoppered bottle) being much more easy than with metals melted in a crucible and simply stirred vigorously.

Plotting the curves with the heavier immiscible fluid (lead, chloroform, bismuth) at the left hand corner of the base of the triangle, the lighter one (zinc, water) at the right hand corner, and the solvent fluid (tin, acetic acid) at the apex of the triangle, it was found that the tie-lines with chloroform-water-acetic acid, always sloped downwards to the left, the angle of slope continually increasing. The right hand branch of the critical curve rises to a maximum elevation, and then descends again to the limiting point, whilst the left hand branch continually ascends to that point. At the limiting point the chloroform and water are in the proportions  $2\text{CHCl}_3, 5\text{H}_2\text{O}$ ; the acetic acid present being less the higher the temperature, i.e. the critical curve for a higher temperature lying *inside* that for a lower one. At points near the limiting point the mixture is extremely sensitive to temperature-variation; a few tenths of a degree will often make all the difference as to whether a single homogeneous fluid results (a "real" mixture), or two different ones, the point indicating the mixture in the first case lying just outside the critical curve, and in the second case inside it.

Analogous results were obtained with the metallic mixtures; with lead-zinc-tin mixtures, the lower ties slope to the left, the upper ones to the right, the limiting points also lying on the right and below the highest point of the critical curve; at this point the lead and zinc are nearly in the proportion  $\text{PbZn}_6$ . Two points, one in the left hand branch, the other in the right, are indicated by the configurations of the tie-lines, corresponding approximately with the definite atomic compounds  $\text{SnPb}_3$  and  $\text{SnZn}_4$  (when aluminium is used instead of zinc, similar configurations are developed, corresponding with  $\text{SnPb}_3$  and  $\text{SnAl}_3$ ). When silver is employed instead of tin, all the ties slope to the left; irregularities of outline (bulges) are noticed, caused by the formation of definite atomic compounds,  $\text{AgZn}_6$  and  $\text{Ag}_2\text{Zn}_6$ ; these bulges are still more pronounced when bismuth is used instead of lead (bismuth-zinc-silver curve). With both silver-lead-zinc and silver-bismuth-zinc curves, the limiting points lie to the left of and below the highest point of the critical curve; with both tin-lead-zinc and tin-bismuth-zinc curves, to the right and below the highest points.

In any given curve, substitution of bismuth for zinc depresses the curve, so that the curve with lead uniformly lies *outside* that with bismuth. The curve for a higher temperature always lies *inside* that for a lower temperature, the effect of temperature-variation being very much less marked at the lower parts of the curve, than at points lying anywhere near the limiting point.

February 4.—"On the Thermal Conductivities of Crystals and other Bad Conductors." By Charles H. Lees, M.Sc., the Owens College, Manchester.

The author commences by referring to Kundt's discovery, that the metals stand in the same order as conductors and as to the velocity of propagation of light through them, and mentions that his experiments were originally intended to furnish data for a similar comparison for crystals, but that their object has been extended.

After some preliminary experiments, he adopted the "divided bar" method, which consists in placing a disk of the material the conductivity of which is required, between the ends of two bars of metal placed coaxially, heating one end of the combination, and observing, by means of thermo-junctions applied to the bars, the distribution of temperature along them—first, with the disk in position; second, with the bars in contact without the disk. When the conductivity of the bar is known, these observations suffice to determine that of the disk.

The ends of the bars which came in contact with the disks were amalgamated, as this was found to be the best method of securing good contacts. These bars were suspended horizontally in a frame, and, by means of screws, set accurately in the required position.

The conductivity of the bar was determined by the method due to Forbes of determining the loss of heat from the surface by allowing the bar to cool and observing the rate of change of temperature, and then observing the steady distribution of temperature along the bar when heated at one end.

The author finds it to be 0.27 C.G.S. unit, and to increase slightly with temperature.

The disks used were of the same diameter as the bar, and were of various thicknesses, in order to make the distribution of temperature throughout the bars nearly the same in each case.

The following are the results obtained. No relation of the kind found by Kundt for metals seems to hold for the crystals experimented on:—

	C.G.S. units.
Crown glass	0.0024
Flint glass	0.0020
Rock salt	0.014
Quartz along axis	0.030
" perpendicular to axis	0.016
Iceland spar along axis	0.010
" perpendicular to axis	0.0084
Mica perpendicular to cleavage	0.0016
White marble	0.0071
Slate	0.0047
Shellac	0.00060
Paraffin	0.00061
Pure rubber	0.00038
Sulphur	0.00045
Ebonite	0.00040
Gutta-percha	0.00046
Paper	0.00031
Asbestos paper	0.00057
Mahogany	0.00047
Walnut	0.00036
Cork	0.00013
Silk	0.0002
Cotton	0.0006
Flannel	0.0002

Chemical Society, January 21.—Prof. W. A. Tilden F.R.S., Vice-President, in the chair.—The following papers were read:—The estimation of oxygen dissolved in water, by M. A. Adams. The author describes an apparatus in which the estimation of dissolved oxygen in water by Schützenberger's method may be carried on so as entirely to avoid loss of oxygen by diffusion. The results obtained by this method are liable to differ according to the rate at which the determinations are effected, higher results being obtained when the operations are quickly performed.—The luminosity of coal-gas flames, by V. B. Lewes. The author has quantitatively studied the actions which occur in luminous gas flames, and also those which lead to loss of luminosity in the flame of a Bunsen burner. He considers that the most accurate method of dividing a luminous hydrocarbon flame into zones, is to regard it as made up of three:—(1) The inner zone, in which the temperature rises from a



comparatively low point at the mouth of the burner to about 1000° C. at the apex of the zone; in this portion of the flame various decompositions and interactions occur, which culminate in the conversion of the heavier hydrocarbons into acetylene, carbon monoxide being also produced. (2) The luminous zone, in which the temperature varies from 1000° to a little over 1300°. The acetylene is here decomposed with liberation of carbon, which imparts luminosity to the flame. (3) The extreme outer zone, in which the combustion is practically complete. The various actions which tend to cause the loss of luminosity in a Bunsen flame may be summarized as follows:—(1) The chemical action of the atmospheric oxygen, which causes loss of luminosity by burning up the hydrocarbons before they, in their diluted condition, can afford acetylene. (2) The diluting action of the atmospheric nitrogen, which, by increasing the temperature necessary to bring about the partial decomposition of the hydrocarbons present, prevents the formation of acetylene, and so causes non-luminosity. (3) The cooling influence of the air introduced, which is able to add to the general result, although the cooling is less than the increase in temperature brought about by the oxidation due to the oxygen in the air. (4) In a normal Bunsen flame the nitrogen and oxygen are of about equal importance in bringing about non-luminosity, but if the quantity of air be increased, oxidation becomes the principal factor, and the nitrogen practically ceases to exert any influence.—The origin of flame coloration, by A. Smithells. This paper was reported in NATURE of January 28, (p. 306).—Note on the action of dilute nitric acid on coal, by R. J. Friswell. If bituminous coal be treated with 49 per cent. nitric acid, a black substance is obtained which is almost completely soluble in sodium carbonate solution and behaves as a nitro-acid; on treating this substance further with nitric acid, a brown acid is obtained which has not yet been examined.—A pure fermentation of mannitol and dulcitol, by P. F. Frankland and W. Frew. The authors have obtained an organism which sets up a fermentative decomposition, not only of mannitol, but also of dulcitol, a substance which has hitherto resisted fermenting bacteria. The products of the activity of this organism are essentially the same in the case of both sugars, consisting of ethyl alcohol, acetic acid, succinic acid, carbon dioxide, hydrogen, and varying quantities of formic acid. The decomposition may be represented by two sets of changes, viz. (a)  $C_6H_{14}O_6 = 2C_2H_5OH + CO_2 + CH_3CO_2H$ , and (b)  $C_6H_{14}O_6 = C_4H_8O_4 + C_2H_4O_2 + 2H_2$ . It appears that two molecules of the sugar are resolved in accordance with equation (a) for every one decomposed according to (b). The organism is termed *Bacillus ethacetosuccinicus*.—Synthesis of hexahydroterephthalic acid, by J. E. Mackenzie and W. H. Perkin, Jun. The sparingly soluble hexahydroterephthalic acid of Von Baeyer is obtained by eliminating two molecules of carbon dioxide from hexamethylenetetracarboxylic acid.—The magnetic rotation of dissolved salts, by W. Ostwald. The author considers that the values obtained by Perkin for the magnetic rotatory power of the ammonium salts of fatty acids in solution are in accord with the electrolytic dissociation theory. This theory does not lead to any numerical value or sign of the difference between the observed and calculated values of the magnetic rotation of electrolytes. In the case of haloid acids and salts the variation is positive; in the case of the oxy-acids negative. It is, therefore, not surprising that molecules with nearly zero variations are capable of existence.—The dissociation of nitrogen peroxide, by W. Ostwald. Using the data given by Cundall, the author has compared the extent to which nitrogen peroxide undergoes dissociation when vaporized, with that which it suffers when dissolved in chloroform. From the results he concludes that it behaves in accordance with Van 't Hoff's generalization that dissolved substances obey the same laws as gases. It appears, however, that in the gaseous state dissociation is far more advanced than in a chloroform solution.—Corydaline, by J. J. Dobbie and A. Lauder. The authors have obtained corydaline in colourless crystals melting at 134° 5. The results obtained on analysis do not agree with Wicke's formula,  $C_{19}H_{19}NO_4$ , but rather with  $C_{22}H_{22}NO_4$ . Analyses of the hydrioidine, platinum-chloride, and methiodide of the alkaloid also give numbers agreeing with this formula.—Silver compounds of thiourea, by J. E. Reynolds. The author has obtained a series of crystalline compounds of thiourea with silver nitrate, bromide, chloride, iodide, and cyanide. These substances contain one, two, or three molecules of thiourea to one of the silver salt, and readily afford silver sulphide when heated a few degrees above their melting-points.

Zoological Society, February 2.—Mr. W. T. Blanford, F.R.S., in the chair.—The Secretary read a report on the additions that had been made to the Society's Menagerie during the month of January 1892.—Mr. W. Bateson, F.R.S., exhibited some Crabs' claws bearing supernumerary prongs. It was shown that these extra parts are really complementary (right and left) pairs of indices or pollices, according to their position of origin, and not repetitions of the two pinners of the claw, as was commonly believed.—Mr. Sclater made some remarks on the breeding of the Ground-Pigeons (*Geophapes*) in the Society's Gardens, and showed that the young of these Pigeons, when first hatched, were not materially different in point of development from those of the typical Pigeons, and that there was consequently no ground for separating the *Geophapes* from the order Columbæ on this account, as it had been recently proposed to do.—A letter was read from Prof. R. Ramsay Wright, inclosing some photographs of the heaps of skulls of the American Bison which are collected on the plains of the Saskatchewan, and piled up at the sidings on the Canadian Pacific Railway, awaiting transport, and which testify to the enormous number of these animals recently exterminated.—Mr. W. Bateson gave a summary of his recent observations on numerical variation in teeth. The facts given related chiefly to specimens of *Quadrumania*, *Carnivora*, *Marsupials*, and other orders of Mammals in the British and other Museums. The author pointed out that the ordinarily received view of homologies between teeth is based on the hypothesis that the series is composed of members each of which is either present or absent. In the light of the facts of variation, this hypothesis was shown to be untenable, and an attempt was made to arrive at a more just conception of the nature of the homology of multiple parts.—Mr. K. Lydekker described part of an upper jaw of a Sirenian Mammal from the Tertiaries of Northern Italy, containing milk-teeth. As these teeth showed a masked Selenodont structure, it was urged that the specimen indicated the descent of the Sirenia from Selenodont Artiodactyle Ungulates. It was incidentally shown that *Halitherium veronense*, Zigno, from the same deposits, belongs to *Prorastomus*, Owen.—A communication was read from the Rev. H. S. Gorham, containing descriptions of and notes on the Coleoptera collected by Mr. John Whitehead on Kina Balu, Borneo. The present communication related to the families Hispidæ, Erotylidæ, Endomychidæ, Lycidæ, Lampyridæ, and others.—Another communication from the Rev. H. S. Gorham and Mr. C. J. Gahan gave an account of some of the Coleoptera collected by Mr. W. Bonny in the Aruwimi Valley, Central Africa.—Mr. P. L. Sclater, F.R.S., read some notes on a small collection of Mammals brought by Mr. Alfred Sharpe from Nyassaland, amongst which was a flat skin of Angus's Bush-bok (*Tragelaphus angasi*), a species of Antelope not hitherto recorded to occur in this district.—Mr. Sclater also gave the description of a new Antelope from Somali-land, proposed to be called *Bubalis swainii*, after Captain H. G. C. Swayne, R.E., who had furnished him with the specimens on which it was based. He likewise exhibited and remarked on some other examples of Antelopes from the same country contained in Captain Swayne's collection.

Linnean Society, February 4.—Prof. Stewart, President, in the chair.—Mr. J. E. Harting exhibited Gould's coloured plate of a humming-bird (*Phaethornis longuemareus*), of which species a pair had made their nest in the drawing-room of Mr. Hamilton, of Queen's Park, Trinidad. The nest was built in a palm about five feet high, standing in a tub within the room. The first egg was laid on December 27 last, the second egg on December 29, and a young bird was hatched on January 12. The circumstance was regarded as quite unprecedented, though Mr. D. Morris was able to quote a case which came under his own observation in Jamaica, wherein a humming-bird had built its nest on the extremity of a saddle-bar in a verandah.—Mr. Harting also exhibited some life-sized photographs of the egg-cases of two species of dog-fish (*Scyllium*), and made some remarks on the mode of deposition and period of incubation as observed in different aquaria.—Mr. F. N. Williams read a paper on the genus *Dianthus*. He pointed out that *Veselia*, *Dianthus*, and *Funica* form a natural group of genera distinguishable from the Silene group by their seeds, which have a facial hilum and straight embryo. *Veselia* may be distinguished from *Dianthus* and *Funica* by having half the number of stamens. There are, however, three characters to be relied on in distinguishing these two genera; (1) the presence of a

spically of bracts; (2) the number of nerves to the calyx; (3) the junction of the claw with the blade of the petal. This last character was regarded as distinguishing very clearly *Dianthus* from *Funica*. In *Dianthus* the blade of the petal is abruptly narrowed into the claw, so that the two are distinct; in *Funica* the transition is gradual. Mr. Williams was of opinion that the species of *Dianthus* might be arranged in three natural groups (sub-genera): (1) in which the flowers are numerous and clustered, as in "Sweet William"; (2) the largest group, in which the flowers are few and usually solitary on the branches of the stems, as in carnations; and (3) a small group intermediate between *Funica* and the true pinks, and corresponding with the genus *Kohlruschia* of Kunth. The number of species recognized by Mr. Williams in this monograph amount in round numbers to 250.—A paper by Messrs. G. J. Hinde and W. M. Holmes was then read, on the Sponge remains in the Lower Tertiary strata near Oamaru, Otago, New Zealand. Near Oamaru there are beds of white, friable siliceous rock of Upper Eocene age, almost entirely composed of Sponges spicules, Diatoms, and Radiolaria, thus resembling in character the Diatom and Radiolarian ooze of the present deep seas. The Sponge remains are all detached; they belong largely to the *Monactinellidæ*, though *Tetractinellidæ*, *Lilhistidæ*, and *Hexactinellidæ* spicules are also present. The smaller flesh spicules of these different groups are perfectly preserved, and thus enable a comparison to be made with existing Sponges, to which generically they mostly belong. In all 43 genera and 113 species have been recognized by their characteristic spicules. Many of the forms have not hitherto been known as fossil. The existing relatives of many of them now inhabit the Indian and Southern Oceans, but some are at present only known from the North Atlantic. The remains of deep-water Sponges are intermingled in the deposit with others hitherto supposed to belong to moderate depths only, but in recent dredgings by H.M.S. *Egeria* off the south-west coast of Australia, at a depth of 3000 fathoms, there is a corresponding admixture of similar spicules.

## PARIS.

**Academy of Sciences, February 8.**—M. d'Abbadie in the chair.—Observations on a note by M. H. Le Chatelier, on the optical measurement of high temperatures, by M. Henri Becquerel.—Silica in plants, by MM. Berthelot and G. André. An examination into the occurrence, distribution, and state, of silica in the spring-wheat plant in various stages of its growth, and into the quantity and state of the silica in the soil in which the plants were grown.—A new chart of the currents of the North Atlantic, by Prince Albert I. of Monaco.—Determination of the freezing-point of very dilute solutions: application to cane-sugar, by M. Raoult. The author describes a new method of taking cryoscopic observations, giving readings to within 1/500 of a degree. The molecular lowering of the freezing-point of water by cane-sugar is represented by a curve, which demonstrates that the author was correct in asserting that sugar gave, like other bodies, a gradual increase in its molecular lowering beyond a certain stage of dilution.—New measurement of the Perpignan base, by General Derrécaigaix. The results are as follows: (1) the measured line, reduced to Delambre's base, gives for the length of this base 11,706.69 m.; (2) this length is verified by the geodesic accordance between the segments and the entire base, to an approximation of 1/250,000. Hence (1) the modern measurement of the Perpignan base makes it longer by 0.29 m. than found by Delambre using Borda's measures; (2) this new length is less than that calculated from the Paris base by only 5 cm.—New researches on the solar atmosphere, by M. H. Deslandres.—A new interpretation of Abel's theorem, by M. Sophus Lie.—On the integrals of equations of the first order which admit of only a finite number of values, by M. Paul Painlevé.—On a new process for the transmission of electric undulations along metallic wires, and a new arrangement of the receiver, by M. R. Blondlot.—Refraction of liquefied gases, by M. James Chappuis. The indices of refraction at zero and under their maximum vapour pressure have been found for sulphurous acid and methyl chloride. For D they are respectively 1.3518 and 1.3533.—The rotatory power of quartz for the infra-red rays, by M. E. Carvallo.—The action of chlorine upon ruthenium: ruthenium sesquichloride and oxychloride, by M. A. Joly.—On a nitro-silicate of silver, and on the existence of a nitro-silicic acid, by MM. G. Rousseau and G. Tite.—On the decomposition of sulphurous acid by carbon at very high temperatures, by M.

Scheurer-Kestner. Sulphurous acid passed over charcoal at a white heat is decomposed in accordance with the equation—



—Chlorosulphide and bromosulphide of lead, by M. F. Parmentier. The chlorosulphide, obtained by a method described, is found to be  $\text{PbS.PbCl}_2$ . Its colour, when suspended in water, is cinnabar-red; when collected, it appears darker. The properties of the bromosulphide,  $\text{PbS.PbBr}_2$ , are similar, but it is more stable than the chlorosulphide. The existence of an iodosulphide is indicated.—Researches on sodium isopropylate, by M. de Forcrand.—On a nitro-derivative of antipyrin, by M. Edm. Jandrier.—On the rotatory power of diacetylartric derivatives; reply to a note by M. Colson, by M. J. A. le Bel.—On the minimum perceptible amount of some odours, by M. Jaques Passy.—The law of absorption of carbon monoxide by the blood of a living mammal, by M. N. Gréhan.—On the fauna of the fresh waters of Iceland, by MM. Jules de Guerne and Jules Richard.—On the structure of the ovule and the development of the embryonic sac of *Dompte-venin* (*Vincetoxicum*), by M. Gustave Chauveaud.

## BOOKS, PAMPHLETS, and SERIALS RECEIVED.

Books.—Stanford's Handy Atlas of Modern Geography (Stanford).—The London Matriculation Directory, No. xi. January 1892 (Clive).—Synopsis of Non-metallic Chemistry: W. Briggs (Clive).—Pocket-book of Electrical Rules and Tables, 8th edition: Munro and Jamieson (Griffin).—Philosophical Notes on Botanical Subjects: Dr. E. Bonavia (Eyre and Spottiswoode).—The First Book of Euclid's Elements: Rev. J. B. Lock (Macmillan).—Hourly Means, 1888 (Eyre and Spottiswoode).—Recollections of a Happy Life, being the Autobiography of Marianne North, 2 vols.: edited by Mrs. J. A. Symonds (Macmillan).—Observations made at the Magdalen and Meteorological Observatory at Batavia, vol. xiii., 1890 (Batavia).  
PAMPHLETS.—Aboriginal Skin-dressing: O. T. Mason (Washington).—Ten Years' Sunshine in the British Isles, 1881–90 (Eyre and Spottiswoode).—Harmonic Analysis of Hourly Observations of Air Temperature and Pressure at British Observatories (Eyre and Spottiswoode).  
SERIALS.—Proceedings of the Royal Society of Edinburgh, vol. xviii., pp. 261–374 (Edinburgh).—Transactions of the Burton-on-Trent Natural History and Archaeological Society, vol. ii. (Bemrose).—The Transactions of the Yorkshire Naturalists' Union, Parts 10 to 16 (Leeds, Taylor).—The Engineering Magazine, February (New York).—The Geological Magazine, February (K. Paul).—Quarterly Journal of Microscopical Science, new series, No. 130 (Churchill).

## CONTENTS.

	PAGE
<b>A Collection of Memoirs on Physics.</b> By Prof. J. J. Thomson, F.R.S. . . . . .	361
<b>The Formation of Beaches</b> . . . . .	362
<b>Egyptian History</b> . . . . .	363
<b>Our Book Shelf:</b> —	
Hutchinson: "The Story of the Hills."—A. H. G. Taylor: "The Optics of Photography and Photographic Lenses."—W. . . . .	364
Mitchell: "The Evolution of Life; or, Causes of Change in Animal Forms" . . . . .	364
<b>Letters to the Editor:</b> —	
A Magnetic Disturbance.—G. M. Whipple . . . . .	364
The New Star in Auriga.—Thomas D. Anderson . . . . .	365
Nacreous Clouds.—T. W. Backhouse . . . . .	365
The Cause of an Ice Age.—Sir Robert S. Ball, F.R.S. . . . .	365
Ice Crystals.—Bernard Hobson . . . . .	365
A Rare British Earthworm. (Illustrated).—Rev. Hilderic Friend . . . . .	365
The Implications of Science.—Miss E. E. C. Jones . . . . .	366
Vacuum Tubes and Electric Oscillations.—Prof. Oliver J. Lodge, F.R.S. . . . .	366
<b>The New Star in Auriga</b> . . . . .	366
<b>Electrodynamic Theories and the Electromagnetic Theory of Light.</b> By Prof. A. Gray . . . . .	367
<b>On some Points in Ancient Egyptian Astronomy.</b> II. (Illustrated). By J. Norman Lockyer, F.R.S. . . . .	373
<b>Superheated Steam.</b> By Lord Rayleigh, Sec. R.S. . . . .	375
<b>Two African Explorers</b> . . . . .	376
<b>Notes</b> . . . . .	377
<b>Our Astronomical Column:</b> —	
Photographic Magnitudes of Stars . . . . .	380
The Zodiacal Light . . . . .	381
<b>The Ancient Tombs and Burial Mounds of Japan.</b> By Prof. Hitchcock . . . . .	381
<b>University and Educational Intelligence</b> . . . . .	381
<b>Societies and Academies</b> . . . . .	381
<b>Books, Pamphlets, and Serials Received</b> . . . . .	384

THURSDAY, FEBRUARY 25, 1892.

THE SCIENCE MUSEUM AND THE  
TATE GALLERY.

WE are informed that various Government Departments are now considering the many questions raised by the Tate Gallery controversy in the real spirit of scientific inquiry—that is, they are at last attempting to deal with the facts, and they are consulting some people who ought to know something about them.

As the President and Officers of the Royal Society, and many other representative men throughout the country, have stated their opinion on the matter to Lord Salisbury in a memorial last year; and as they were pretty certain to have known the facts before they committed themselves to any statement involving them in great responsibility if they were wrong; the friends of science can only rejoice that at last the Government Departments are dealing with the matter in a scientific way.

The facts are as follows. In our Museum arrangements, while books and pictures—or, in other words, literature and art—are thoroughly represented, from the Museum point of view, on a scale worthy of the nation, only three branches of science—natural history, geology, and mineralogy—have so far been provided for, and by the Natural History Museum. This was pointed out about twenty years ago by the Duke of Devonshire's Commission; and the many advantages which would be certain to accrue to an industrial nation like ours, from collections representing the various physical, chemical, mechanical, and metallurgical sciences and their applications to industry, were very clearly referred to.

The Government, one may almost say, of course, took no notice of this important recommendation, or next to none. In 1876 the Royal Commissioners for the Exhibition of 1851—a body thoroughly well capable of judging of the importance of the Duke of Devonshire's recommendation—showed their opinion of its importance by offering a plot of ground stretching from Queen's Gate to Prince's Gate, and £100,000 to build this Science Museum. This offer, the Government of the day—most of the Governments of the day knowing and caring little about science, although they are so glad to receive donations for art—declined. So matters went on, Committee after Committee being appointed, reporting, and having their deliberations ignored, until at last, as a result of a Committee appointed by the Treasury itself, the plot of ground which the Government might years ago have had for nothing, was purchased, and purchased, of course, in strict relation to the discussions which, as we have shown, had been going on for the last eighteen years. At least, if that be not so, why was it purchased at all?

We now come to the plot of ground. It contains 350,000 square feet. What facts have we before us to aid us in answering the question as to whether this plot of ground is sufficient to do for all other sciences what the Natural History Museum does for three? Here, of course, if possible, we must appeal to facts, if facts exist. Let us assume that the new Museum is to be built on the precedent afforded by the Natural History Museum.

The exhibiting space in the Natural History Museum consists of 152,000 square feet. To provide this exhibiting space in a building in which, of course, many other things besides exhibiting space have to be considered, the ground plan of the existing building contains an area of 162,000 square feet. The building itself, however, stands in a plot of ground covering about 500,000 square feet, and in this way ample possibilities of future extension are provided.

We are first, then, face to face with the fact that, assuming the Museum which is to do for all the other sciences what the Natural History Museum does for the three named, can, in a few years, be restricted to the same exhibiting area; we begin with a space of, roughly, 150,000 square feet *less* for that which must eventually be the *larger* Museum. Anyone will see that, in the nature of things, it is unlikely that the Museum which has to look after the interests of all the inorganic sciences, and their infinite applications to the arts (by which, of course, the industrial arts are meant), will always remain smaller than that Museum which has to provide for biology chiefly. But the matter, unfortunately, does not end here. It is practically certain that the Royal College of Science will require considerable additions to meet the demands made upon it for science teachers. It is perfectly well known already to all educationists that it has already entirely overflowed the small and ill-contrived building in which it is located; and the Professors of Physics and Geology are already camping out in temporary buildings of the most inconvenient description. We believe it is thoroughly conceded by the Government that new laboratories for physics, astronomical physics, and chemistry must be at once erected. Now, it is perfectly certain that, at this time of day, such laboratories as those, with their various appendages, cannot be erected on a space much less than 100,000 square feet; so that it comes to this, a site already too small for the purposes of a Science Museum and its future extension—if it is to be treated like the Natural History Museum—must have filched from it, for other scientific needs, another slice of 100,000 square feet.

This may be, perhaps, permitted, because, although the Science Museum may lose in area, it would gain enormously in advantage, for the reason that the teaching in the future may be given in close relation with the instruments which are used in it.

The suggestion that Mr. Tate should be allowed still another 100,000 square feet from this plot—from a plot containing less than 300,000 square feet available for building purposes—of course was preposterous from the beginning, and would have been at once shown to be impossible if the problem had been considered at all from the region of hard, dry fact. Unfortunately, it was not so considered, and hence an apparent antagonism between the interests of science and art, which has been going on now nearly a year. We have attempted to show that the question is not a question of sympathy—it is a question of fact; and now that the Chancellor of the Exchequer is dealing with the facts, as they ought to have been dealt with in the first instance, there can be no longer any doubt as to which way the issue will be decided.

We believe it is contended by some who are not acquainted with the exact terms of reference to the last

Treasury Committee that their very indefinite suggestion as to the space to be provided to meet present needs really referred to their view as to the maximum amount of space which a Science Museum should be allowed to cover. We are certain that the scientific members of that Committee would repudiate any such opinion, and they would quote, as we have quoted above, the actual facts concerning the Natural History Museum as negating any such idea.

Finally, it is advisable to point out the terrible want of any sense of perspective on the part of the Legislature on matters relating to science and art. We do not object to any expenditure the Government may choose to make upon art, but it is our clear duty to point out that the interests of science must not be neglected in order that art may be encouraged. The £70,000 paid for the land which has given rise to this discussion is the same sum as that given not long ago for a single picture. The "British Luxembourg"—whatever that may be—which the Government is supposed to be now fostering, was intended to contain most of the pictures now in the South Kensington Museum; so that the edifying spectacle was to have been, or indeed may yet be, seen, of emptying all the picture galleries at one end of the Museum while £400,000 of public money is being expended—this has been agreed to by the Government with alacrity—in building new picture galleries at the other. Nor is this all. The Tate Gallery, if built, is to be maintained by the Government: we are informed this will cost at least £4000 annually. Here, then, is another endowment of, say, £160,000 for art. We do not object to this if the nation so wills it; but is it wise that all this time the training of our science teachers—our great requisite just now—is to be carried on in sheds, and that the only concern that the Government shows in relation to the Science Museum, which is to include the Patent Museum, is to still absorb year after year the patent fees, which ought in justice to be used for the improvement of our national industries?

#### CHEMICAL TECHNOLOGY.

*Manual of Chemical Technology.* By Rudolf von Wagner. Translated and edited by William Crookes, F.R.S., from the thirteenth enlarged German edition, as remodelled by Dr. Ferdinand Fischer. With 596 Illustrations, 968 pages. (London: J. and A. Churchill, 1892.)

WHEN a book has reached a thirteenth edition, it may usually be assumed that its form and contents are so familiar to all who are likely to be interested in the subject of which it treats as to require no description, and that it has attained so substantial a reputation as to be independent alike of praise or blame flowing from the pen of the critic. In the case of the book before us, however, the author is no longer living; and having completed in 1880 the eleventh edition of his work, the care of future issues devolves upon others. There is probably no subject which changes so rapidly, owing to the advances of science and the incessant activity of inventors, as chemical technology, or the application of chemistry to useful purposes in the industrial arts; and a glance at the table of contents of such a book as this is sufficient

to remind one of the vast range of subjects with which chemistry has to do. It is the extent and diversity of these subjects which suggests at once the idea of the difficulties which must attend the compilation of such a treatise even when the work of so distinguished a technologist as von Wagner is carried forward by editors so eminent as Dr. F. Fischer and Mr. Crookes. That they have discharged their duty in no perfunctory spirit is evident from the fact that many sections are entirely new, and that, as compared with the eleventh German edition, more than half the text and the illustrations have been replaced by new matter. And further, as pointed out by the English editor, a manual such as this must be in many respects adapted to the conditions of the country where it is written, and, if translated for use elsewhere, it requires modification. The prices of raw materials, of fuel, and of labour, and the laws in different countries have in each case their influence upon the conditions under which chemical industries are carried on. As already remarked, a book in its thirteenth edition must have been found useful by a good many people, but the first thought that passes through the mind in turning over the pages of Wagner's "Technology" is—For whom can this book have been intended? It treats of everything: of fuel and metallurgy, of water, acids, and alkalies, of pigments and dyes, of glass and cements, of food and fibres, of leather, soap, wood, matches, and many smaller subjects. In the limits of 950 pages it is not possible to provide all the details essential to each process which would be sought by a manufacturer, and an examination of the volume shows that the treatment of the successive subjects is very unequal. The impression derived from its perusal is that, on the whole, it is most likely to be useful to senior students or to chemists who wish for general information relating to chemical manufactures, but that the efforts which have evidently been made to incorporate into this new edition an account of modern processes are spasmodic, and not always successful.

The articles on soda and on chlorine, for example, are among the best in the book. The several processes for the recovery of sulphur from alkali waste, including the Schaffner-Helbig and the Chance patent processes, are described with some detail; and the Weldon-Péchiney process for obtaining chlorine from magnesium chloride is described at length with the aid of numerous illustrations. But even in this latter case, in view of the importance of the process, which is still on its trial, information more recent than December 1887, might have been expected. There is no reference to more recent processes for electrolyzing alkaline chlorides; but this, perhaps, is expecting too much in the way of the "latest intelligence"; and doubtless the same remark applies to the absence of any description of liquid chlorine as a commercial article. This, however, does not account for the curious error by which the number formerly given as the density of liquid chlorine, 1.33, is assigned to the gas. The admirable work of Knietsch (*Annalen*, 259) on the properties of liquid chlorine deserves to be had in remembrance, more especially as it was done in the laboratory of an alkali-works, with industrial objects in view.

A really unsatisfactory article is that which relates to

iron and steel. The ores are stated to be roasted in heaps and in special kilns, but no description is given of the process. The blast-furnace to which the longest description is devoted is an open-top furnace of forty years ago. No figure is given of a modern English blast-furnace; the form shown in the cut, and dismissed in eight lines of text, is not to be seen in this country. The cup and cone charger, general in Great Britain, is not even mentioned. There is no straightforward account of the successive chemical changes which are supposed to take place as the charge descends in the furnace, but, without introduction, the reader is plunged into a disproportionately long discussion of the "heat conditions of the blast-furnace." There is no description of the *tuyères*, though it is mentioned that they are cooled by water, nor of the sand casting-bed, nor of the resulting pigs. In the account of "crude" iron, as it is called, it is surely not enough to say that, "according to the nature of the carbon, it is distinguished as white and grey crude iron," and then to give just six lines to each of these two varieties, without so much as mentioning the various grades distinguished by the numbers familiar in every ironworks, or the purposes in the forge or the foundry to which they are severally applicable. Following the description of "crude" iron is a section occupying about three-quarters of a page on the examination of iron and steel, which might as well have been omitted, as it is quite useless. The same inadequate treatment is noticeable throughout the article, and to an English reader it must appear strange that English metallurgists, with the exception of Bessemer, Thomas and Gilchrist, and Bell, whose name appears once, are generally ignored. This seems to be one of the articles in which the English editor has not been sufficiently careful to supply the modifications indicated in the preface as requisite in order to adapt the book to the conditions prevailing in this country.

Turning now to subjects of a different character, there is the vast field of coal-tar and the colours derived from the tar hydrocarbons. The colours are dealt with in sixty-seven pages. In comparison, therefore, with other subjects in the same volume, this important and interesting department of applied chemistry receives perhaps its fair share of space; but, recalling the fact that in another book on applied chemistry recently published nearly the same number of pages is devoted to naphthalene and its derivatives alone, it is obvious that considerable condensation must have been effected in the work before us. In connection with this article, every chemist who has any feeling for consistency in chemical nomenclature must protest against the playful variety of spelling which the editor permits in the names of the hydrocarbons. On the same pages we have *paraffine*, *benzol*, *naphthaline*, *anthracene*, *triphenyl methan*. This is really too bad!

Referring to the thirty pages devoted to dyeing and tissue-printing, we find a practical acknowledgment of the inadequacy of the treatment which many subjects receive by the insertion of a list of books to which the reader is referred for further information. And this recalls the fact that elsewhere throughout the volume references to authorities in the shape of original memoirs, books, or patent specifications are rarely given. This is

an omission which might with great advantage be repaired in a future edition, not only because further information is often essential, but because there are, necessarily, scattered up and down the pages of such a comprehensive work as this a good many statements which require some qualification, or, at any rate, some positive evidence to make them completely acceptable, as well as others which are manifestly antiquated and obsolete. For example, the statements (p. 223) as to the influence of the addition of aluminium to iron and steel ought not to be put forward without proof. Certainly the fact that the manufacture of pure aluminium is now practically abandoned tends to show that it has not been found so valuable in connection with iron and steel as was at one time asserted.

There is no very pressing necessity for introducing photometry into a book on chemical technology; but if there is a reason for its introduction, there must be a still stronger reason for making the description practical. It is not so in this case, for while Bunsen's photometer is referred to, rather than described, in eight lines, Violle's attempt to utilize the light emitted from melted platinum as a photometric unit is described at length, with a figure, and the article concludes with the statement that the amyl acetate lamp will probably in time supersede the other units. We think not.

Manufacturers who have managed to keep the details of their plant and their processes practically secret must derive some amusement from books which profess to describe their manufactures. The successful English monopolists of phosphorus-making (Messrs. Albright and Wilson) are represented, no doubt correctly, as making more phosphorus than anybody else; but we can imagine the quiet smile with which they would regard the pictures of apparatus said to have been invented and employed by themselves, as well as such ridiculous statements as (p. 410) that "bone ash is now the only material used by phosphorus-makers," &c. If it were not for the lofty air of knowledge with which such things are described, it would not matter greatly; but it would be more candid towards the reader if the writer of such an article as that on phosphorus would begin by declaring roundly that he does not *know*, but only *imagines*, that the following is the process likely to be employed.

The difficulty of purifying the pages of successive editions of so large and complex a book of phraseology which is obsolete or inappropriate is illustrated on p. 398, where a brief exposition is given of the views entertained by "the late Dr. Gerhardt" concerning the constitution of fulminating mercury. Not a word is mentioned of more recent chemical discussions on the fulminates, though they have been renewed more than once in the five-and-thirty years which have elapsed since the death of the distinguished French chemist.

The editors have produced a volume which contains much entertaining and instructive reading. From what has been said, however, it is obvious that the reader must not expect to find the whole truth, and nothing but the truth, set forth in any such cyclopædic production. It is not possible for any one man, or any three men, to array, without mistake, the accumulated stores of human knowledge and experience in such a subject as applied chemistry.

W. A. T.

## AN AGRICULTURAL TEXT-BOOK.

*Elements of Agriculture.* A Text-book prepared under the authority of the Royal Agricultural Society of England. By W. Fream, LL.D. Pp. 450, 200 Figures. (London: John Murray, 1892.)

DR. FREAM'S new book, the first edition of which was exhausted on the day of publication, is a distinct gain to agricultural literature. We naturally expect such a work from Dr. Fream's pen to have the botanical portions of the subject dealt with at considerable length, and in this we are not mistaken, half the book being taken up by the discussion of the various plants with which the farmer has to deal, either as crops or weeds. This division has to be made, to some extent, at the expense of other branches of the subject, which is perhaps not quite a desirable thing to do in a general text-book; though it might be argued that it is far better to do one thing well than to do several things indifferently, and Dr. Fream has certainly done one thing well in his treatment of "The Plant." The style is good, and the descriptions very lucid, concise, and sound, the book containing a vast store of information in small compass. There is not, however, a single reference to any original paper, an omission especially to be regretted when the author is discussing the Rothamsted experiments; in fact, we think that the addition of a list of the papers published by Lawes and Gilbert would have considerably enhanced the value of the book.

The author divides his work into three parts. Part I., which occupies the first 77 pages, treats of the origin and properties of the different kinds of soils, their improvement, cultivation, and manuring. Part II., "The Plant," occupies a full half of the book (pp. 78-302). The first two chapters of this part treat of seeds and their germination, and the structure and functions of plants, these subjects being discussed in popular, but very instructive fashion.

Chapter xi. treats of the cultivated plants of the farm, grouped under the natural orders to which they belong. This is the longest chapter in the book, and includes 30 pages given to the consideration of the natural order Gramineæ. Then follow a short chapter on weeds, and chapters upon harvest machinery and the management of grass land. In chapter xvi., the theory of rotations is ably dealt with; the various crops of the farm, with their cultivation, are considered in turn; this chapter also contains a handy table of the characters of the seeds of the common farm crops. In the second column of this table, opposite *mangel*, is the statement, "Should germinate at least 120 per cent. (see p. 141)." On turning to p. 141 we find the following:—

"The seed of commerce (*mangel*) consists of the ovary with its seeds, embedded in the swollen base of the perianth, which thickens and hardens as it ripens, becoming angular and somewhat woody. Hence, when a *mangel* or beet seed is set to germinate, it is not unusual for two or three shoots to appear from a single seed."

On p. 97 are some remarks on this very matter, with definitions of fruit and seed: "The *fruit* is the ripened ovary, the *seed* is the fertilized and ripened ovule." Is it not better to adhere to these definitions, and thus avoid

speaking of the germination of a sample of seed as *over 120 per cent.*?

On p. 282, Dr. Fream speaks positively upon the much-debated practice of burning diseased potato-haulms. Further research upon the liability of old haulms to propagate the fungus (*Phytophthora infestans*) is much needed. The writer's own observations by no means lead him to consider them so dangerous in spreading disease as some people think they are. The question of the utility of sulphate of copper as a remedy for potato disease is dismissed in very few words. It is to be hoped that the subject will receive fuller treatment in succeeding editions, as many trials have recently been made; and although these have not always been attended with success, many of the failures reported turn out upon investigation to be due to the fact that the Bouillie Bordelaise (or other mixture) was improperly prepared or improperly applied. It would appear that impurities in the mixture exert considerable influence upon its efficacy as a check on the growth of the fungus. The use of a mixture of sulphates of iron and copper with lime generally gives negative results; and even the presence of ferrous sulphate in any quantity in commercial bluestone appears at times to exert a deleterious effect.

The third part of the book contains a short account of the structure and functions of farm animals, their various breeds, and also chapters upon feeding. The subject of dairying is dismissed in a chapter of 20 pages, and is the least satisfactory portion of the book. Under "Cheddar Cheese making" is given a process which is rather indefinite, and seems a sort of mixture of several methods; the instructions for this process are vague, the temperatures (where given) are rather uncertain, and nothing whatever is said as to the proper condition of the curd at the end of each operation. On p. 429 this remark is made:—

"Real Stilton, for example, is a double cream cheese, the cream of the evening's milk being added to the morning's milk."

"Real Stilton" of this nature is a myth; the so-called "cream Stiltons" are made from two curds, and do not contain added cream, the term being used (rather ambiguously we confess) to signify that no cream was abstracted from the milk used in making the cheeses.

A few errors in the text may be mentioned here. On p. 65 and elsewhere, ammonium carbonate is spoken of as a volatile gas; it would be more accurately described as a volatile solid. The average percentages of albuminoids in certain foods given in Table xviii. (p. 343) are most of them too low. In Table xx. (p. 344) the percentage of albuminoids in cotton cake is put down at 23.17, whilst it is given as 19 in Table xviii. on the previous page; the former value is more nearly an average one. The percentages of soluble carbohydrates in some feeding stuffs given in Table xxi. are not quite satisfactory; those for wheat, barley, and bean straws are much too high, especially that of 35 for bean straw; about one-fifth that figure would be nearer the truth. We think it would have saved space, and much trouble and confusion to the student, if Tables xviii., xix., xxi., xxiii., xxiv., and xxvi. had been combined, and the full analyses of the feeding stuffs given in a single table.

Table xxxi. (p. 408) is headed, "Percentage of nitrogen and minerals in the fasted live weights of cattle, sheep, and pigs." This heading should be, "Amounts of nitrogen and minerals in 1000 pounds fasted live weights, &c."

The illustrations in chapters xxv. and xxvi. are very poor indeed, especially Fig. 190, which is perhaps intended as a puzzle print. Also Figs. 171-3 are very bad attempts to convey an idea of what a cow is like. Figs. 160-4 are equally poor.

Apart from these details, we cannot but say that the book as a whole is an admirable work, and superior to anything of its kind which we have yet seen. It will prove a boon, alike to students and to educated farmers.

W. T.

#### HYLO-IDEALISM.

*Further Reliques of Constance Naden.* Edited by George M. McCrie. (London: Bickers and Son, 1891.)

WE have already in these pages expressed our opinion, in a notice of her "Induction and Deduction," that, had the hand of Death been withheld, Miss Naden would have made valuable contributions to philosophic thought. The volume of "Further Reliques" now before us serves to justify this opinion. It is questionable, however, whether her friends have been well-advised in including the "Geology of the Birmingham District," admirable as it is as a student's prize essay. In any case, since it was included, it would have been only just to Miss Naden to have requested someone acquainted with geological nomenclature to revise the proofs. On a single page we have *Trianic* for *Triassic*, *Keupes* for *Keuper*, *Llandeils* for *Llandeilo*, and *Paradoyidian* for *Paradoxidian*. This essay is dotted over with such misprints (the genus *Orthis* being printed, on p. 25, both *Orthiis* and *Orttus*). Nor are other parts of the book entirely free from errors due to careless editing. On p. 4, *destruction* is printed where the sense requires *distinction*; and on p. 160, *evidence*, where the author clearly meant to write *eloquence*.

As we before pointed out, for Miss Naden the fundamental principle in philosophy is the famous Protagorean formula of relativity, that "Man is the measure of all things, of things that are that they are, and of things that are not that they are not." In a kind of parable she describes the creation of the external world:—

"A myriad etherial waves, of inconceivable minuteness, enter the tiny window of the eye, and beat against the delicate lining of its darkened chamber. The pulsations are taken up, and transmitted along the optic nerve to the base of the brain, and thence to the gray thought-cells of the cerebral hemispheres. And in these gray thought-cells lives the God who says, 'Let there be light,' and there is light. If the optic nerve be an inefficient messenger; if, maimed or paralyzed, it fail to convey the vibrations received from without, the creative fiat will never be issued, and the world will remain, for the God of that one cerebrum, without form, and void. He is not a First Cause, since a stimulus is needed to set him in action; but he is certainly the only authentic Creator of the world as yet discovered by science, philosophy, or religion."

Whether this way of putting the matter is in the best possible taste, we do not pretend to decide. It is with

Miss Naden's philosophical position, not with any other aspect of her views, that we can deal here. Philosophically, her view is, that the gray thought-cells are for her, and for each and all of us, the creators of the world. "But here," she continues—in her article on "Hylo-idealism," prefixed to certain letters addressed to her by Dr. Lewins, of the Army Medical Department—

"But here comes the most critical point of the inquiry. If the universe be simply a more or less coherent vision; if its very solidity and extension be but parts of the 'realistic' drama, how are we to know that there is any such thing as matter? . . . How are we to be sure that the brain itself really exists, and that the all-generating cells are not mere illusory appearances?"

How does Miss Naden answer this question, by which she is by no means the first to be puzzled?

"The puzzle," she says, "is not so hard as it looks. The uttermost sceptic tacitly assumes the possibility of argument; that is, of a course of reasoning, in which every step is dependent on the preceding step, while the origin of the whole is some group of observed facts. If this be a delusion, and the last step stand in no kind of causal connection with the first, evidently argument is impossible, and the sceptic's lucubration shares the general invalidity. A succession of mere mental phenomena, of mere inert pictures, cannot constitute reasoning, because one inert picture cannot produce or condition another. If a mental state possess no property except the property of being perceptible, it is obviously purely passive, and exerts no real influence upon subsequent mental states. Now, as this position is utterly unthinkable, and is not less destructive to scepticism than to materialism, we are obliged to assume the existence of some active basis of thought—that is, of something which thinks. What we assume of the individual self we extend analogically to other men, who are to us other selves. And having seen that sensation and motion follow upon excitation of the brain, and are suspended or destroyed by paralysis of the brain, we are justified in restoring our thought-cells to their proud creative eminence, and in proclaiming that they constitute this 'active basis of thought'; that they think, and therefore exist."

In an earlier paper on "Scientific Idealism," included in the "Further Reliques," Miss Naden says:—

"For the present I must be content to plagiarize from Descartes, and to say of the cerebrum, '*Cogitat ergo est.*' It can appear to us only phenomenally, and we cannot speak of it otherwise than in terms of phenomena; but here, at least, we are forced to assume an underlying *noumenon*, while renouncing the vain hope of penetrating to its essential nature by reason or intuition."

So, after all, the thought-cells which have been restored to their proud creative eminence and proclaimed as constituting the "active basis of thought," turn out to be phenomena like the rest of the "realistic drama," and "even the vibrations supposed to impinge on the surface of the body, and the molecular tumult propagated along the nerves, are merely convenient intellectual representations of the unknown"—to which Dr. Lewins adds in a footnote, "and nothing until assented," without, however, explaining how "nothing" in the process of assentment becomes something.

Such, so far as we understand it, is hylo-idealism. In it one recognizes an old friend under a new name. It would seem that Miss Naden admitted with reluctance the phenomenal nature of the all-creative thought-cells.

As it is, her views are hardly consistent. She generally appears to regard the organism or the thought-cells as the only reality—a reality set over against, and in marked contradistinction to, the “realistic drama” of the surrounding universe. But, in the passage above indicated, she admits the phenomenal nature of the thought-cells, and confesses an unknown *noumenon*. We do not think that Miss Naden's philosophy had reached its final form when Death so untimely snatched her hence.

C. L. L. M.

### PHYSIOGRAPHY.

*The Realm of Nature.* An Outline of Physiography. By Hugh Robert Mill, D.Sc. Edin., F.R.S.E. (London: John Murray, 1892.)

THE scope of physiography has perhaps been more misunderstood than that of any other subject. It had its birth in the Government system of science examinations, and the new name was applied to distinguish the subject from the older and narrower one of physical geography, which was so widely taught in elementary schools.

In the great majority of the text-books which have hitherto appeared, the authors have rigidly followed the lines laid down in the syllabus of the Science and Art Department, and have generally contented themselves with stating facts, more or less accurate, without properly considering their inter-relation. It is a great relief to turn from these to the book before us. It is written independently of all examinations, and in it the true place of physiography among the sciences is clearly defined.

The book is one of the University Extension manuals, of which the editor (Prof. Knight) says: “Their aim is rather to educate than to inform.” No better subject could therefore have been selected as one of such a series, and Dr. Mill fully bears this aim in mind. Indeed, in this respect the book is worthy to be compared with the “Introductory” science primer written by Prof. Huxley some years ago. The opening chapter deals with such matters as “Nature,” “Science,” “Use of the Senses,” “Reason,” “Common Sense,” “Cause and Effect, and ‘Natural Laws,’” all of which are set forth very clearly, and made deeply interesting. For the benefit of those who may have doubts as to the meaning of physiography, we may quote the following from this chapter:—

“Physiography means literally the description of Nature (p. 1). . . . It describes the substance, form, arrangement, and changes of all the real things of Nature in their relations to each other, giving prominence to comprehensive principles rather than to isolated facts (p. 3). . . . In order to have a just conception of the universe, the results of specialized research must be fitted harmoniously together. This is the function of physiography, which has, consequently, a unique value in mental training, being at once an introduction to all the sciences and a summing up of their results. It enables a beginner to obtain a quicker insight into any of the special sciences and a fuller grasp of it, while, at the same time, a student versed in any one special science is enabled to appreciate far more fully than an unversed one its relation to all others and to the system of the universe” (p. 13).

Succeeding chapters deal with subjects somewhat after the order of the syllabus of the Science and Art Department. It is only necessary to say of these that they are excellent, and that they have been revised by well-known specialists, including such names as Prof. Tait, Dr. Copeland, and Dr. John Murray. In chapter xvii. there is an admirable account of “Life and Living Creatures,” in which is given a good outline of the classification, distribution, and functions of animals and plants. The final chapter is reserved for “Man in Nature,” and deals with the distribution of the various types of humanity, the effects of environment, migrations, and man's power of altering the course of Nature's works. A useful list of memoirs and books is appended to each chapter.

The book is fully illustrated, chiefly by new diagrams, and there are nineteen beautiful maps, which have been specially prepared by Mr. Bartholomew, whose competence for such work is well known. These maps form an important feature of the book, and illustrate, amongst other things, earthquake regions, isotherms, rainfall, and the evolution of continents.

The whole book shows signs of the greatest possible care in preparation, and it is not an easy matter to suggest improvements. It is a very valuable contribution to the literature of the subject, and we trust that it will meet with the appreciation it deserves. It is admirably adapted for all thoughtful persons desiring an insight into scientific methods; and although not intended as a book for use in schools, all teachers and students of the subject will do well to make themselves acquainted with its contents.

A. F.

### OUR BOOK SHELF.

*Grasses of the South-West.* Plates and Descriptions of the Grasses of the Desert Region of Western Texas, New Mexico, Arizona, and Southern California. Part II. By Dr. George Vasey, Botanist, Department of Agriculture. 50 Plates, with descriptive Letterpress. (Washington: Government Printing Office, 1891.)

THE first part of this work was issued in October 1890, and duly noticed in our columns. It also contained 50 plates. It is a pity that in this second part the numbering from 1 to 50 is begun over again. It would have been much more easy to cite the plates continuously from 1 to 100. The present part goes all through the series of tribes again, and includes 4 species of *Paspalum*, 3 of *Stipa*, 4 of *Muhlenbergia*, 5 of *Sporobolus*, 9 of *Triodia*, 5 of *Diplachne*, and 4 of *Eragrostis*. Most of the species are endemic, and very few of them have been figured before. None of them are British species, but one of the *Stipas* is a variety of the common European feather-grass (*Stipa pennata*). A good general handbook of grasses is one of the books most urgently wanted both by systematic botanists and agriculturists; and the United States Department of Agriculture is doing a very useful work in bringing out these bulletins. The next two bulletins are to be devoted to the grasses of the Pacific slope, and the four numbers will bind up into one volume, containing 200 figures.

*Sporting Sketches in South America.* By Admiral Kennedy. (London: R. H. Porter, 1892.)

THE sketches presented in this volume appeared originally in *Land and Water*, and are now reprinted with only such slight changes as “time and circumstances have



rendered necessary." They are very pleasant reading, and should be of considerable service to naval officers, yachtmen, and sportsmen who may visit South America. The commission of the *Ruby* in South American waters extended over three and a half years, and during that time the officers seem to have missed no opportunity of indulging their taste for sport. The game killed amounted to 13,349 head. What was killed was never wasted, for there were on board 250 persons to be fed. Although Admiral Kennedy has much to say that will be especially interesting to sportsmen, they are by no means the only class of readers to whom he appeals. He visited many districts which are well worthy of being described, and the impressions they produced upon him are invariably recorded in a fresh, simple, and straightforward style. The text is illustrated with copies of some pen-and-ink sketches by the author.

#### LETTERS TO THE EDITOR.

[The Editor does not hold himself responsible for opinions expressed by his correspondents. Neither can he undertake to return, or to correspond with the writers of, rejected manuscripts intended for this or any other part of NATURE. No notice is taken of anonymous communications.]

#### Cirques.

PERMIT me, while thanking Mr. I. Russell for his friendly criticism of my views as to the origin of *cirques* (p. 317), and for a copy of his memoir on the Mono Valley, in which his own are developed, to indicate the reasons why I remain unconvinced.

(1) The first part of his criticism appears to me to be wide of the mark. I never said that the three conditions, quoted by him, were necessary for the formation of *cirques*, only that they were "the most favourable." I have described two *cirques* in granite (*Geol. Mag.*, 1871, p. 535), and seen them in other crystalline rocks.

(2) I never said that those topographical features might not be associated with other dispositions of rocks, which are often found in *cirques*. I stated that for the production of *cirques*, not only certain materials, but also a particular machinery, were required. Lines of cliffs, ravines, alcoves, corries, are numerous in the Alps: *cirques* are comparatively rare.

(3) The instances described in my original paper (*Quart. Journ. Geol. Soc.*, 1871, p. 312) were called *cirques* at that date, and, I believe, still retain the name. They are in all essential respects identical with Gavnarie and similar places in the Pyrenees, which are always called *cirques*. Hence, it appears to me, Mr. Russell cannot elude my arguments by proposing a new terminology. Moreover, to call these places alcoves, is to misuse the word. An alcove holds a bed, or screens two lovers in earnest conference from over-curious eyes—it is a small affair. The diameters of the Alpine *cirques* are measured by hundreds of yards; their walls by hundreds of feet. Mr. Russell's studies in the Appalachians (unless I misunderstand him through ignorance of the locality) appear to me to indicate no more than that (as I have repeatedly affirmed) no real demarcation can be drawn between *cirques*, corries, and bowl-like heads of valleys. Of each I have seen examples, little as well as big. The formation of an alcove, as described by him, is only a special case of an action, identical in kind (but different in degree and environment) with that by which the above-named are produced. As it seems to me, he proves, not that *cirques* and alcoves are genetically distinct, but that they are genetically identical. One stream will make an alcove, many a *cirque*.

(4) I have never denied that under certain conditions a basin (generally quite shallow) may be scooped out by ice-action on the floor of a corrie, but the peculiar "tooth-drawing" action of the base of the *névés*, postulated by Mr. Russell, appears to me only an hypothesis. I stated, when it was propounded by Mr. Helland, that I knew of no evidence in its favour, and much in opposition (*Geol. Mag.*, 1877, p. 273); I repeat the same now. Wherever I have seen the bottom of a corrie uncovered, the rock has been smooth and ice-worn, not rough with the sockets of extracted "plugs" of rock.

(5) As a *bergschrund* usually narrows in descending, the tension of the ice should be at a minimum at the base of the *névés*, and I do not believe that atmospheric cold is appreciably

more potent there than at the bed of a glacier. Moreover, as the ice must move more slowly in the *névés* basin than in the glacier, the former standing to the latter in the relation of a pond to its effluent, the friction there should be least.

(6) Some of the Alpine *cirques* lie rather low, and are not in a position where glaciers would first appear, as is shown by the fact that they are now full 3000 feet below the snow-line. Perhaps, however, Mr. Russell supposes rock wrenched away to a depth of quite a thousand yards. If so, I have nothing to add to what I wrote in 1871 and 1877. All that I know of the Alps and of other mountains is opposed to any such notion.

(7) Above three at least of the *cirques*, described by me, the cliffs rose in inaccessible steps to the very summit of the range. From the highest peak of the Diablerets one could almost throw a stone on to the floor of the Creux de Champ, a full mile below; the two *cirques* near the Surenen Pass are immediately under the crest of the range (as shown in my diagram). Yet there are the streams fed by snow-ledges, which, though comparatively narrow, keep them still at work. Doubtless, in some cases the recession of the walls may bring to an end the work of excavation. But even in Egypt, in a *cirque*-like glen beneath a narrow crest, Mr. Jukes-Browne found evidence of streamlets (*Geol. Mag.*, 1877, p. 477); and I may cite Herr J. Walther (*Abhandl. d. Sächs. Gesellsch.*, xvi. 345) for the occurrence of "amphitheater oder circushäler" in that country, though he attributes more to the action of wind than I should venture to do.

I might continue, but it may suffice to say that the result of twenty years' experience has been increased confidence in the general accuracy of the views expressed by me in 1871. These, it appears to me, Mr. Russell combats only by attempting a distinction, which I believe to be non-existent, and devising a method of glacier-erosion, which I believe to be not only mechanically impossible, but also contrary to the facts of Nature. T. G. BONNEY.

#### Bedford College and the Gresham University.

YOU have given publicity to various communications on the subject of the Albert or Gresham University; may we therefore request that you will extend a like favour to us, and insert a brief statement from one of the Colleges for Women, deeply interested in everything affecting higher education in and for London?

The following are some of the grounds on which the Bedford College, London, opposes the Draft Charter:—

(1) That the Bedford College, London, for Women, provides a complete academical course in the two faculties of arts and science, and therefore feels that from the very outset it is entitled to be included in any proposed University for London, on an equal footing with University and King's Colleges, with due representation on the Council. For such immediate affiliation the Draft Charter does not make any provision.

(2) That should the Draft Charter become law, a University would be created which, while exercising only some of the functions of a Teaching University, would do this in such a manner as to effectually prevent the foundation of any Teaching University which should be capable of expanding to the ever-growing demands of the Metropolis.

(3) That while the Act of 1871 abolished all ecclesiastical tests in the Universities of Oxford, Cambridge, Durham, and all Colleges therein to such an extent that all denominational Colleges are separate from the Universities, this Draft Charter of the Albert University allows one of its component Colleges to impose ecclesiastical restrictions. The Council, therefore, in its petition to both Houses of Parliament claims that the Bedford College be made an original constituent College in any new University for London, with due representation in the governing body, and prays that the present Charter be not granted unless so amended as to be far more comprehensive, more adequate to the present and future needs of the Metropolis, and free from all ecclesiastical restrictions.

W. J. RUSSELL, Chairman of Council.

LUCY J. RUSSELL, Honorary Secretary.

Bedford College, London, February 19.

#### The Implications of Science.

CAN you allow me space to reply to Miss Jones's courteous letter (p. 366), which I shall have the more pleasure in doing as I hope to be able to clear up the points in dispute between us?

I think it is clear—Miss Jones at least admits so much—that

some part of the meaning of a term is determined arbitrarily; either by public opinion for general use, or by the individual reasoner, if he wishes to use the term for some special purpose of his own. For this does not imply that there ever was a formal contract as to the meanings of terms. The fact that terms do not mean the same to people of different nations is enough to show that the determination of the meaning by each nation is, in part at least, essentially arbitrary. It is also, I think, clear that there is a part of the meaning of some terms at least which is not arbitrary, when once the arbitrary part has been settled. There is a slight ambiguity about my use of the word "definition," which, however, when once noted, need cause no confusion, as the context will always show in which sense I am using it. Commonly a "definition" denotes an assertion which determines the arbitrary part of the meaning of a term; but when I speak of "the definition" as opposed to "the import" of a term, I mean not this assertion itself, but that part of the meaning of the term which it determines. This explains how it is that I do not regard "the definition" of a term (as opposed to its import) as a *thing*. Even if it is clearly conceived in the mind it is only an abstract idea; but the point is that it is not necessary that it should be conceived at all. Thus it is not necessary that a definition by connotation should be "of something," if that means that the term should have denotation. Even if the term has any denotation, *i.e.* if the mind grasps it as denoting a thing or idea, this denotation must, in a symbolic argument, be regarded as merely "accidental clothing."

Just as some part of the meaning of a term is arbitrary and some part not, so in any system of logic some part of the system is arbitrary and some part not. Now, either the denotation or the connotation of a term may be laid down arbitrarily, but *the connection between the two is not arbitrary*. One cannot arbitrarily lay it down that "such a thing possesses such attributes." If, therefore, a definition is to be an arbitrary assertion, it must only lay down either the denotation or the connotation of a term, and not parts of each. It would, of course, be logically permissible to use the word "definition" in a different sense, but then definitions would not be arbitrary assertions. This is exactly what is done if the assertion "Two straight lines cannot inclose a space" is called a definition by denotation; and therefore, in my system of logic, I cannot admit it to be a definition. This is one of the arbitrary features of my system. But it is not arbitrary when I say that in such assertions as "Nothing can both be and not be," and "Twice two is four," there is nothing absolute at all. The truth of these assertions is determined entirely by the arbitrary parts of the meanings of their terms. Miss Jones says: "If definitions were purely arbitrary, as Mr. Dixon holds, what would prevent my saying that *Four* ( $1+1+1$ ) means *twice two* ( $1+1$ ) + ( $1+1$ )?" Precisely; this is exactly the point. *There would be nothing at all to prevent it*. Boole actually did this very thing, as his law of indices in his mathematical analysis of logic. According to his law  $a^{x+1+y} = a^{(x+1)+y}$ .

There remain one or two minor points to be answered. As to induction, I think Miss Jones's view is substantially the same as mine. Of course it is possible to set out an inductive generalization in a syllogistic form as Miss Jones does; only the whole of the induction is then contained in the assumption of the major premiss—the syllogism itself is in no sense inductive.

If Miss Jones thinks the truth of the formula  $(a+b)^2 = a^2 + 2ab + b^2$  is deduced by generalization from a single concrete instance, how does she explain the fact that sometimes  $(a+b)^2 = 0$ , as in Grassmann's "Aeuessere Multiplication," and sometimes  $(a+b)^2 = a+b$ , as in Boole's logic?

I see nothing to differ from in the paragraph about S and P; except perhaps that if I define such a term as "metal" by denotation I do not say "This and all other things like it in certain respects" are metal. That would be mixing up denotation and connotation in one definition. I say only "This, and this, and this, . . . are metal."

The explanation of the point about the mathematical truths is simply that I do not consider the assertion "Two straight lines cannot inclose a space" as a mathematical truth at all, if "straight line" is defined by denotation. I certainly believe it to be true, but its truth is not of the same nature as that of the assertion "Twice two is four," or even "*Cogito, ergo sum*"; it is neither a truism nor a necessary truth, in my senses of those terms, but can only be established by induction.

EDWARD T. DIXON.

Trinity College, Cambridge, February 19.

NO. 1165, VOL. 45]

### The Value of Useless Studies.

It is rather surprising that Prof. Ayerton should indulge in covert sneers at Universities for devoting themselves to useless studies. It certainly ill becomes one whose life is bound up with electrical science, which is of such recent growth that nobody can pretend to forget how it owes its origin to those who studied it while useless. If Universities do not study useless subjects, who will? Once a subject becomes useful, it may very well be left to schools and technical colleges, to patent-mongers, and the trade. Mr. Bury is, on the other hand, mistaken in two respects. That a subject is useless is hardly worth considering as a recommendation for its being made *compulsory* on students. There are too many useless subjects for that. The great objection to compulsory Greek is that it is the principal stumbling-stone in the way of any literature being studied by ordinary University students. The Bible produced very little effect until it was read in translations; and the danger of a pagan revival, if ancient literature were studied without the obstruction of difficult languages, is the best reason for insisting on these languages in a Christian University. The second mistake of Mr. Bury is that it is any part of the business of a University to *teach*. Universities should certainly give facilities for students to *learn*. It is the business of the students to learn. If they are so ill prepared that they have not acquired the art of learning, they should go to a college or school or private teachers, and get taught; for teaching is the business of these institutions and persons. The business of Universities is to advance culture and knowledge, and to afford students an opportunity of learning how to do this. Prof. Ayerton, by omission rather than by commission, seems utterly unable to appreciate the value of literature for its own sake. How can all this fierce toil he extols so justly advance a lot of savages?

GEO. FRAS. FITZGERALD.

Trinity College, Dublin, February 13.

### The Nickel Heat Engine.

IN trying Mr. Smith's experiment on the rotation of nickel (*NATURE*, January 28, p. 294), I find my disk has a more complex action.

It will be remembered that the nickel is mounted on a vertical axis, and has the poles of an electro-magnet put near two points, A and B, 90° apart. Let C be any point in the larger arc, and suppose heat is applied to A.

I find that as first the disk moves in the direction ACB with a hesitating, uneven motion; it revolves several times, and almost develops into a steady rotation, when it beats back, oscillates for a while, and goes off with a brisk even spin in the direction BCA. After about two minutes this fails, and a new start is attempted the opposite way, but there is little more movement, until time has been given for cooling.

It makes no difference at which pole the heat is applied. The disk is 50 mm. diameter, rather less than 1 mm. thick, and is covered with lamp-black.

W. B. CROFT.

Winchester College, February 12.

### THE UNIVERSITY OF LONDON.

PROBABLY before this letter is in type the Charter of the Albert, or, as it is now to be called, the Gresham, University, will have been presented to Parliament. What will be its ultimate fate remains to be seen. But I have sat through a long night's debate in the House of Commons to see a Government turned out in the small hours of the morning on a University question. I do not suppose that the proposed Charter will raise an issue of that importance. But I think that the Government may not be unmindful of past history, and, in what is probably the last session of a moribund Parliament, may not be willing to push very vigorously what is perhaps the crudest scheme of University organization which has ever been proposed in this country.

Before Parliament takes so serious a step—as founding a new educational institution, the question may fairly be asked, On what ground is it necessary? Everyone knows that we have a University in London which is a State institution; and one may not unreasonably inquire,

In what respects is it inadequate to its duties ; and, if so, why cannot its defects be remedied without beginning the work all over again ?

To neither inquiry has, it seems to me, any very satisfactory reply at present been given. The reason perhaps is that beside the ostensible reasons for the Charter which are put forward, there are others in the background which are less conveniently avowable, and which therefore it is anything but easy to meet.

Of the former, the most important is that the existing University does not teach. This is an undoubted fact. If, however, it were provided with a body of Professors, as has often been suggested, it might teach just as much as Oxford and Cambridge do. That defect is clearly, then, not irremediable. But, on a little further investigation, it turns out that something more than teaching is meant. What is desired is that the teachers shall also have the control of the examinations. What is wanted is to introduce into London the teacher-examination system, which is said to be the distinctive feature of Universities in Germany. To quote an able article in the *Standard* of January 19 :—

“There must be a Teaching University in order that the teachers might control the studies, and the degrees be a recognition, not of mere knowledge (which might or might not be superficial), but of sound intellectual training.”

Now, I have discussed this position at some length in the pages of NATURE, and I need not repeat what I have already said. But it may be pointed out that, though the teacher-examiner system once obtained to some extent in the British Isles, it has almost entirely been abandoned. As Lord Sherbrooke used to remark, “Teachers no longer sample their own goods.” Their doing so led, I think it cannot be doubted, to serious abuses, the possible nature of which is sufficiently obvious. Even in the English Universities, some of the Colleges practically had the entire control of the education of their undergraduates ; but they deliberately abandoned this exclusive privilege, and handed over the business of testing the performance of their pupils to their respective Universities ; in other words, they intrusted the business of sampling their goods to those who had nothing to do with their manufacture. The Scotch Universities most closely approximated to the German system ; but here, again, external examiners have been introduced, who undoubtedly were intended to act as a check upon the Professors and their teaching.

It can thus, I think, be shown to demonstration that the system which obtains in Burlington Gardens is not really so anomalous as it is made to appear. The teacher-examiner cry is, then, of the nature of a reaction ; and though to a certain extent I am not without sympathy with it, I am not sure that, on the whole, it is not a mischievous reaction.

Now, when a great institution like the University of London is attacked, one attaches naturally some importance to the quarter from which the attack comes. I quite admit that the University, perhaps from an excessive sense of its own dignity, has rather allowed the case against it to go by default, and has done little in its own defence. But the world outside may judge for itself. I am prepared to contend that there is no examining body in the world which does its work in a more efficient and conscientious way. Its examination rooms are crowded ; it commands the services as examiners of the most distinguished teachers of the country ; and whether in science, law, or medicine, amongst those who have successfully submitted to its ordeals are to be found the names of some of the most distinguished men of the time. It seems clear, then, that the attack on the University would not come from either the students or the public. It can hardly be doubted that the latter is more than satisfied. When parents allow their sons to embark in

University studies, they like to get something tangible as a result ; and in a degree at Burlington Gardens they undoubtedly do get something the value of which is generally accepted.

The complaint comes, however, from the teachers ; and this not in the provinces, but in London alone. Their case was put before the Commission by Prof. Lankester in a very striking and able way. I do not doubt that his evidence has produced a very powerful effect. But having studied it, I am bound to say that, having been a graduate, an examiner, and a member of the Senate of the University, I cannot accept all he says as giving a fair account of the inner working of the system. The burden of his complaint is that the teacher is unreasonably fettered in giving the best and most modern kind of teaching by the restrictions imposed upon it by the University. In so far as there is ground for the complaint, I think it admits of remedy. But I cannot refrain from remarking that the provincial teachers who send candidates to the London examinations—and who, I suppose, are not, on the average, less competent and enthusiastic than their London colleagues—do not, as far as I can ascertain, in any way sympathize with their complaints. On the other hand, Prof. Lankester was for ten years an examiner in the University, and when he last left office I am much mistaken if he had not succeeded in moulding the curriculum in his subject practically into entire accordance with his own views. And even under the system as it exists I observe in his evidence that he admitted to Sir William Thomson, that “a teacher may, with judiciousness, of course, and common-sense in his teaching, teach the best that he knows.”

I cannot keep feeling, then, that in the outcry raised by some of the London teachers there is something a little unreal. The existing system neither works so badly, nor is it in itself so bad, as it is represented to be.

The Privy Council, however, appears to have thought differently, and has set itself to the task of creating a Teaching University for London. And this is what Parliament is asked to sanction. The fatal objection to the scheme is that the title is a misnomer ; the proposed University is, as I have already pointed out in NATURE, in effect, no more a Teaching University than the existing institution.

It is perfectly clear that by a Teaching University is meant, by those who understand what they are talking about, a University of the German type, governed and administered throughout by the professorial body. If I understand his views, this is the solution of the difficulty which Prof. Karl Pearson desires. I am far from saying that I am opposed to the establishment of such an institution. It would certainly be an interesting experiment, and it might be a great success. It might be created out of University College standing alone ; and for my own part I have always wondered that that distinguished place of study has never sought such a transformation. It would, of course, require a profound reconstruction of its constitution, and the total elimination of what may be called the lay element in its government. Or it might be effected, though with more difficulty, if University and King's Colleges could be induced to fuse. Prof. Lankester contemplated such a possibility ; but it is probably as hopeless as to try to get anything but an emulsion out of oil and water.

The organization of such a Teaching University is not without its drawbacks, and I am not at all sure that London would be the best seat for one. The system is only a success in Germany because Universities are very numerous, and the number of students in each for the most part not very large. The essence of the system, as I understand it, is the close personal contact of teacher and student. Each gets saturated, so to speak, with the other ; at the end of the curriculum the Professor knows, or thinks he does, all that the pupil has acquired, and

gives him his degree accordingly. I paint the picture in its most attractive colours. And for pupils of a certain type I believe the system to be excellent. But for the large majority I am not so sure; and I think that under such a system a little independent examination would often act as a considerable surprise both to teacher and taught.

It seems to me that the fact is often lost sight of that education in all its forms is rather a tedious business. What the teacher has to deal with are not merely the enthusiastic few who march with joy alongside their instructor, and scarcely see the obstacles that bestrew the path, but the large mass, headed at the best with stolid industry in front, to tail off with incorrigible straggling behind. Here the discipline of the examination-room, backed by parental wrath at failure, seems to me well-nigh indispensable. Even in such cases as these, no doubt personal contact with the teacher can do much; but then the classes must be small. The limit is soon reached when the individual powers of the teacher, however energetic, are reduced to a vanishing quantity. I have found myself that in a class of forty I reached the extreme limit on which I could hope to produce any effective direct impression. Frankly, I do not believe that for large classes, such as might be expected in London, the teacher-examiner system has any merit at all. I think myself that, if the teacher directs and organizes the teaching to the best of his powers, he may, with distinct advantage, leave the testing of the results to other hands. I know that this is what I should prefer myself; and I speak with the experience of a man who has spent, and not wholly without success, some of the happiest years of his life in the work of teaching.

But I certainly agree that the teacher should have something to say in the business of examining. He does, in London, already have a good deal to say as a matter of fact, but very indirectly. I would remedy this by giving all teachers of University rank a definite status in the University.

The bare statement of the fact that the University of London is merely an examining body does very inadequate justice to the work it has accomplished. It has undoubtedly stimulated and disciplined the studies of vast numbers of persons whom the older Universities would never have touched. And it has reacted on the teaching given in London and elsewhere by insisting on a progressively high standard. The educational influence has been consequently far-reaching, and in my judgment not small. This is effected by the schedules or syllabuses which are prescribed by the Senate and from time to time are varied as the progress of instruction in each subject makes change desirable. It is notorious that by this means the University of London has compelled the teaching bodies which send it candidates to develop the efficiency of their methods of instruction.

I am quite prepared to admit that in theory the machinery by which this result is brought about is not perfect. But in practice, like so much else in this country, it works tolerably well. In some of the evidence given before the Commission it is almost implied that the Senate draws up the schedules itself. But, having been both an examiner and a member of the Senate, I know something of the process. Generally speaking, it is something like this. An examiner finds that an existing schedule is scarcely in touch with the best current teaching. He communicates his opinion to the Senate, and suggests alterations. The Senate generally calls to its assistance one or more of the past examiners in the subject, and also any persons of acknowledged competence whose judgment will probably lead them to a right decision. The result is that, if the alterations proposed by the examiner are found to meet with general approval, they are adopted. In time the process is repeated; and probably no year ever passes without

something of the kind being done. Practically, the work is well done, and the general esteem in which the degrees given at Burlington Gardens are held appears to me a tolerable proof of the fact.

It is evident that what I have described is accomplished by what may be called semi-official means. I should prefer myself to have it done by a more definite organization. If Faculties were constituted in the University, the most experienced teachers might meet to settle the schedules in the best possible way. Even then some would probably not be wholly satisfied; but they would have at least the opportunity of explaining their views to their fellow-teachers, and, if reasonable, it is improbable that they would not meet with some recognition.

Another very important result would flow from the organization of the Faculties. One of the absurdest things about the proposed Charter is that, apart from medicine, except University and King's Colleges, it ignores the existence of any other educational institutions which either at present exist, or are certain hereafter to be created, for the educational needs of so vast a city as London. A great evil at the present time is the isolation of such institutions. They do not recognize each other's existence or work in any way in conjunction. If their teachers, under the *ægis* of the central University, could be brought together to confer on educational matters, it can hardly be doubted that instruction in London would be better organized, gaps filled up, and wasteful overlapping obviated. All this might be done without any interference with the autonomy of the separate institutions, and by men exchanging ideas in conference and discussion.

There is one point on which the new Charter has been attacked with which I do not in any way sympathize. The inclusion of King's College in the proposed University is objected to on the ground of its being a denominational institution. But in Australia and Canada the association of denominational Colleges with the Universities is found a simple and effective solution of difficulties which for a long time will probably be insuperable in any other way. One of the most interesting things in the history of English Universities in modern times has been the removal to them of Nonconformist Colleges. For my part, I can see no possible objection to their being admitted ultimately to full University privileges. If the new University is to be accepted, it is idle to object to the admission of King's College, or to demand that it should abandon its characteristic features as the price of admission.

To sum up the position. The present University is denounced because it fetters the teaching and is not in touch with it: this turns out to be rather a matter of form than of fact. To remedy this a new Examining University is to be created, on much the same lines as that already existing, which in its turn is to be allowed to go on exactly as before. Surely, in the whole history of the reform of institutions, nothing so futile was ever proposed.

The real academic need of London is left perfectly untouched. This is the organization of the higher University teaching. I am more and more convinced that a distinction ought to be drawn between what may be called ante-graduate and post-graduate study. The former, leading up to the ordinary Bachelor's degree, may very properly be left to the Colleges. More than this, without a vast increase of endowment and staff, I do not see how they can accomplish. I regard a student who has taken his Bachelor's degree as having learnt the technical language of his study. He may then, in a considerable number of cases, devote himself to original inquiry. And this the University of London encourages him to do, as examination is no longer compulsory for the Doctorate. It may be, and in fact is, obtained by original work embodied in a thesis. I confess I should like to see the University of

London provided with a body of superior Professors, who would not merely add to its distinction by their own labours and public instruction, but would guide the studies and researches of the young graduates. With the right men for Professors, and such picked students as the vast area of London would supply, I do not doubt that the reputation of the University of London would on no distant date rival that of any in the world. I hope Prof. Karl Pearson will forgive me if I appropriate in this connection a portion of his letter in the *Academy of December 19*:—

"The professorships ought to be the best in England, and the chief posts, at any rate, might remain in the gift of the Crown; the laboratories and libraries ought to be the best equipped in the Kingdom, and the University ought to draw students and investigators, not only from the five millions of London, but from the Greater Britain over the seas. Such a University would not only be able to retain in London men like Burdon-Sanderson, Seeley, Gardiner, Sylvester, and Lankester, but it would bring others there."

With the main idea expressed in these words with so much enthusiasm I most heartily agree. But I think those understand their countrymen and the possibilities of things best who would use, as I would, the existing University as a foundation. It has deserved well of the State; it has done its appointed work in the past well: instead of abusing it, we should strive to remove its defects, and give it higher work to do.

Two possible objections to my proposition may be considered. It may be said that such professorships are not wanted in London because such professorial teaching is supplied by Oxford and Cambridge. My reply is, that only a small portion of the population pass through those Universities, and London would draw from a much larger field. Again, it may be objected that the Professors of the existing teaching institutions in London would object to the creation of posts of a superior grade. On the other hand, such posts might stimulate ambition; they would be the prizes of the academic career. To object to them seems to me as reasonable as for a stuff-gownsmen to object to the existence of judges, or for a curate to that of bishops.

The depletion of London of its most distinguished teachers, which continually goes on, is a real loss to its intellectual life. Dr. Dollinger says:—

"The force which moves the world, that which brings on the important crises in the history of mankind, is not to be found in material interests and passions, but in the great ideas which it is the business of Universities to work out."

Why should London, of all places in the world, dismiss from its midst, as it has long continued to do, those whose gift it is to open up most successfully new territory in the unknown world of knowledge? Yet the depletion goes on. Not one of the five officers of the Royal Society is at the moment resident in London. The President attends its meetings from Glasgow, and the Senior Secretary from Cambridge.

I must say a word about Gresham College. The promoters of the Albert University, whose untiring energy would be invaluable in a better cause, have, no doubt, done a clever thing in securing the adhesion of this obsolete institution to their scheme. Years ago I attended one of the prelections with two friends. The Dean of Manchester favoured, very unwillingly, an audience composed of ourselves and a few casual passers-by, whipped in apparently by the beadle, with a demonstration of Euclid I. 47, in the Latin tongue. Yet the institution which had descended to this mere husk of formality had once, if tradition is to be believed, been one of the most famous seats of learning in the world, and Francis I. is said, in emulation of it, to have founded the Collège de France in Paris. I believe the present Gresham Professors

are not quite so sleepy as they were; but the contrast between the two rival institutions is more than melancholy. That Gresham College can nowadays clothe its dry bones and live is more than doubtful. It is, no doubt, only too glad to undertake the "teaching" department of the new University, which proposes to carry on its examining work in the empty building in Basinghall Street.

Kew, February 20.

W. T. THISELTON-DYER.

*A PRELIMINARY STATEMENT OF AN INVESTIGATION OF THE DATES OF SOME OF THE GREEK TEMPLES AS DERIVED FROM THEIR ORIENTATION.*<sup>1</sup>

MR. LOCKYER has made out I think quite satisfactorily that the Egyptian temples were so oriented that the rising or setting of some conspicuous star on or near the axis of the temple, and visible from the adytum, would give warning of sunrise; and he applied to me for particulars of Greek temples for the purpose of seeing if there was any analogy, and the comparison appeared to promise a favourable result. Mr. Lockyer had found, before he had proceeded far in these studies, that he had been anticipated to a considerable extent by Herr Nissen, of Bonn, who has published several articles on the subject in the *Rheinisches Museum of Philologie*, and has brought within his scope both the Egyptian and the Greek temples. There is room, however, in the inquiry for a distinct work on the Greek temples, and especially with the help of more exact measurements of the orientation angles than Herr Nissen has made use of; as he appears to have contented himself with magnetic bearings—which are liable to considerable local variations, which are sufficient in an inquiry like the present to vitiate many of the conclusions that may be founded on such measurements—and there is a want of recognition of the influence of an elevated horizon. I had taken, in several instances, astronomical observations with a view to the more exact orientation of different temples, but something more is wanted even in the case of most of these—namely, the apparent altitudes of the mountains in the directions of the axes of the temples. I wish also to add that, but for Mr. Lockyer's suggestion, I should probably not have carried the inquiry further than I already had done.

The great value of the inquiry lies in this: that it offers a means of determining, within tolerably close limits, the date of the foundation of a temple—not, perhaps, in most cases (although in some I believe it does) of the very structure which we now see, but of an earlier foundation on the same site. The key to the chronology lies in the movement of the stars with reference to the local horizon, owing to what is called the precession of the equinoxes. The object the ancients had in using the stars was to employ their rising and setting as a clock to give warning of the sunrise, so that on the special feast days the priests should have timely notice for preparing the sacrifice or ceremonial, whatever it may have been:

"Spectans orientia solis  
Lumina rite cavis undam de flumine palmis  
Sustulit," &c.

The inquiry, even in its present state, is sufficient to establish a very high probability that the principle is a true one. There is nothing vague about it. It has to be kept within very severe limits, and it holds good nevertheless.

No stars can be accepted except from among the brightest, unless conspicuous star groups may have been used instead. Again, of single stars, only such can have been used for orientation in Greek temples which during

<sup>1</sup> Being the substance of a paper read to the Society of Antiquaries on February 18, 1892.

a period not incompatible with reasonable archæology rose or set very near the line of the sun's course at some period of the year; and a further restriction is this, that the rising or setting must be just so far in advance of sunrise as to enable the star to be seen from the adytum of the temple, and, at the same time, not preceding it by any longer interval than is necessary.

If, in addition to this, we find, as is frequently the case in the Egyptian temples, and is not without parallel in Greece, that as the star to whose point of rising or setting the axis of a temple was first aimed worked away from its then position by *precession*, either the doorway of the temple was altered, or a new temple founded alongside, so as to retain the desired observation; and in every case of such new temple being so built it is found to have followed the same cult as the original; if, in addition to this, in different provinces temples are found of which the cult is known, and which are so planned as to be able to use the same star—with such decided differences of orientation, however, as were prescribed by latitude and the local circumstances of the surrounding heights—we obtain a further strong corroboration, and one that will in many cases be sufficient to determine the cult, where this has not been otherwise pointed out.

One further step requires to be taken to occupy the ground with perfect confidence—viz. to inquire what analogy is there between the days of the month when the sun would rise ushered in, as it may be said, by the temple's peculiar star, and the days of the festivals as derived from historical sources. In this comparison we must not expect a coincidence on every point.

The date of the temple foundation in many cases is pre-Homeric, whilst the basis of the historical account of the date of the feast is probably post-Persic. There may have been an interval of nearly 1000 years between the two, so that there is room for changes. Again, owing to their double system of reckoning months and years, considerable variation in the dates given by Mommsen, whose authority I mainly follow, is quite possible; and besides this, in some of the cases given below, the orientation day, if I may so call it, may be in fault one or possibly two days for want of the exact particulars of the site to which I have made allusion.

Firstly, speaking of Attic feasts, the great temple at Eleusis is an example very much to the point. The star which seems to have determined the orientation is Sirius, shining as it rose at midnight along the axis of the temple on September 14. The Eleusinian mysteries are stated to have commenced on the 16th of that month. In this case the sun was not looked for; the weird light of the star reflected from some combination of jewels was more likely to have been suited to the mysteries. It is perhaps less likely that this ceremony would have been changed than in most of the other cases.

The axis of the older Erechtheum had the central star of the fine constellation Aquarius setting heliacally on August 9.	} The lesser Panathenaia, dated August 13-14.
Warning of the sunrise at Sunium was given by the setting of the Pleiades on October 20.	} A feast to Minerva and Vulcan is dated October 30.
The star $\alpha$ Arietis rose heliacally to the older Olympieum at Athens, April 2, more than 1000 years B.C.	} The feast Olympia is recorded for April 19 in later times.
The temple of Diana Brauronia on the Acropolis of Athens agreed with the rising of Aquarius (the central star $\zeta$ Aquarii in particular) on February 21 at the presumed date of its foundation.	} The Little Mysteries were celebrated February 21.—N.B. A temple of Diana was in close connection with the great temple at Eleusis.

In the earliest times, as already explained, the stars were used as the only available clocks, but probably by the end of the sixth century, whether by the discovery of

the behaviour of the stars or by the invention of the water-clock (which is recorded to have been used to some extent in the fifth century), or other approximate means of measuring time, the dependence on the stars alone had ceased; and the later temples, in Greece at any rate, appear to have been built without any reference to these.

At Athens this applies to the existing or new Erechtheum, the Theseum and the temple of Nike Apteros, which temples do not seem to have been built parallel to any old foundations. The old foundations under the Erechtheum have a very different angle. The sunrise, however, was considered in these just as much as before, for owing to the artistic instinct of the Greeks, they seem invariably to have secured for their principal festivals the fine effect of the first sunbeam on the statue; but as all the temples, whether old or new, admitted of two axial coincidences with the sunrise—one which might have a clock star (as it may be called) to announce the dawn; the other, except by rare accident, having none, the desired effect would have been attained on both occasions when the sun had the same declination.

It will be obvious that if the axis of a temple in any latitude had been directed due east (the horizon also being level), the rising sun would coincide with it at both the spring and autumn equinoxes. Similarly every other amplitude would have two solar coincidences (provided that is, in accordance with what has just been stated, the axis fell within the solstitial limits). When it had been found that the precessional movement had taken away the star from the direction of the axis, there would have been no reason for preferring one of these solar coincidences to the other, and the feast could have been shifted to a different date if it had been thought more convenient. It would appear that something of this sort may have taken place at Athens, for we find on the Acropolis the Archaic temple, which seems to have been intended originally for a vernal festival, offering its axis to the autumnal sunrise on the very day of the great Panathenaia in August.

The Chryselephantine statue of the Parthenon, which temple followed on the same lines as the earlier Hecatompedon (originally founded to follow the rising of the Pleiades after that constellation had deserted the Archaic temple alongside), was lighted up by the sunrise on the feast to the same goddess in August, the Synæcia, instead of some spring festival, for which both these temples seem at first to have been founded.

The temple at Sunium, already quoted for its October star-heralded festival to Minerva, was oriented also axially to the sun on February 21, the feast of the lesser mysteries.

Of temples of later foundation we have the following for which no suitable stars can be found:—

The Erechtheum, its sun axis days are March 2 and September 4, the latter being the date of the *Nicetaria*, the special festival of that temple, supposed to record the celebrated contest between Minerva and Neptune, considered to have been on September 3. Another instance is the Theseum.

The *Thesea* are put down for October 8-9. The sunrise theory points out either March 7 or October 7. Does not this fact restore the disputed title of Theseus to this temple?

There cannot be so much known respecting the feasts in the other provinces.

The Olympic games were held, according to most authorities, soon after midsummer, but by others in the autumn. I quote on Nissen's authority the following:—

420 B.C., Sept. 14. 416 B.C., Aug. 31.	412 B.C., Sept. 12. 408 B.C., Sept. 2.
---	---

The heliacal rising of the star Spica ( $\alpha$  Virginis) seems to belong to the Heraeum, and indicates September 15. The Isthmian games took place either in May or

August, according to the Olympiad. The axis of the temple at Corinth coincides with the sunrise on both those months, but to only one of them (that of May) is a star applicable.

Further confirmation of the truth of this general theory—namely, that the amplitudes of stars determined the orientations of temples—lies in the fact that in the majority of instances, at any rate, the same star belongs to the same cult. I am satisfied that this can be established for the Egyptian temples. In Greece we find the following.

The star  $\alpha$  Arietis is the brightest star of the first sign of the Zodiac, and would therefore be peculiarly appropriate to a temple of Jupiter. The heliacal rising of this star agrees both with the Olympieum at Athens and that at Olympia. There is a considerable difference in the deviation of the axes of these two temples from the true east; but this is exactly accounted for by greater apparent altitude of Hymettus over the distant Mount Pholœ.

The Pleiades are common to the following temples of Minerva, viz. the Archaic temple on the Acropolis, the Hecatompodon, and Sunium. In the two former it is the rising, the latter the setting star.

a Virginis or Spica must have been supposed to be sacred to Juno. The Heræum at Olympia agrees exactly with this view, and the Argive Heræum can be referred to no other; but, as the foundations of the earlier Heræum are not now visible, the exactness of the coincidence cannot be thoroughly established without re-excavating part of the site. There is nothing, however, inconsistent to this view in what is known about it. The nomenclature of the temple of Juno at Girgenti rests on a rather weak historical basis; but Spica entirely supports it.

There must have been something in common between the temples at Corinth, Ægina, and Nemea. The two last, at any rate, are reputed temples of Jupiter, and I have reason to think that also the Temple of Jupiter at Girgenti agrees with the same star—namely, Antares.

Approximate dates derived from the orientation of Greek temples.

Star.	Name of temple.	Place.	Month and day.	Year of foundation. B.C.	Star rising or setting.	No.
Pleiades ( $\eta$ Tauri) ...	Archaic temple of Minerva ...	Athens ...	April 20 ...	1495	R	1
	Hecatompodon temple of Minerva ...	Athens ...	April 25 ...	1120	R	2
	Temple of Minerva, Sunium ...	Sunium ...	October 20 ...	1125	S	3
Sirius ...	Temple of Ceres, Eleusis (for midnight mysteries) ...	Eleusis ...	September 14	1380	R	4
Fomalhaut ( $\alpha$ Piscis Australis) ...	The same for sunrise ...	Eleusis ...	November 18	1350	S	5
	The Heræum, Olympia ...	Olympia ...	September 15	1300	R	6
Spica, i.e. $\alpha$ Virginis.	The Heræum, Argos ...	Argos ...	February ...	{ about the } { same time }	S	7
	The Heræum, Girgenti ...	Sicily ...	September 15	1180	R	8
	Jupiter Olympius, Athens (temple attributed to Deucalion) ...	Athens ...	April 1 ...	1135	R	9
Antares ( $\alpha$ Scorpii) ...	Jupiter Olympius, Olympia ...	Olympia ...	April 3 ...	760	R	10
	Temple at Corinth ...	Corinth ...	May 1 ...	700	S	11
	Jupiter Panhellenius, Ægina ...	Ægina ...	May 6 ...	670	S	12
	Nemea, Temple of Jupiter ...	Nemea ...	similar to	two last	S	13
	Oldest temple at Epidaurus (the Hiero) ...	Epidaurus ...	July 29 ...	1270	S	14
Aquarius ( $\zeta$ Aquarii)	Older Erechtheum, Athens ...	Athens ...	August 9 ...	920	S	15
	Diana Brauronia ...	Athens ...	February 21	750	R	16
	Temple of Themis, Rhamnus ...	Rhamnus ...	September ...	about 1150	R	17
$\delta$ Corvi (?) ...	Temple of Nemesis, Rhamnus ...	Rhamnus ...	September ...	780	R	18

Temples of later foundation for which no heliacal star has been found.

The Theseum ...	Athens ...
The new Erechtheum ...	Athens ...
The temple of Wingless Victory ...	Athens ...

The above table of approximate results, which I have put together, must for the most part be considered preliminary, and subject to amendment when further particulars have been ascertained, which I am in hopes of being able to obtain in the course of the present season. Nevertheless, I do not think that as respects the examples mentioned in Nos. 1, 2, 9, 12, and 16, there will be much need of alteration, as of these I am already in possession, though not of all, yet of the most important measurements. Of the remainder I do not feel so confident, but there is still a good deal that can be pointed out in respect to some of them which is consistent with historical and architectural archaeology.

Olympia must have been a sacred spot long before the Olympiads began to be dated, and the Heræum there appears to be the most archaic temple structure that exists in Greece. The date suggested by the orientation, 1300 B.C., does not seem unreasonable.

Then we come to the establishment of the Olympiads,

which began 776 years B.C. Compare the date of the great Temple of Jupiter derived from its orientation, 760.

The temple at Corinth was thought by archaeologists of the past generation to date from about the middle of the seventh century B.C. The date I get from its orientation is 700.

The temple at Ægina, it is evident from its architecture, is somewhat later than that at Corinth or the Olympian Jupiter. That is also the orientation view of the case. At the same time, I think that the interval between Nos. 11 and 12 ought to be more than thirty years. I rather expect that more exact measurements at Corinth will throw back somewhat the date of that example. Want of clear weather obliged me to be content with magnetic bearings at Corinth, and these may easily be at fault as much as 1°

## VOLCANIC ACTION IN THE BRITISH ISLES.

AT the anniversary of the Geological Society, held on the 19th inst., the retiring President, Sir Archibald Geikie, gave the annual address, which was devoted to a continuation of the subject treated of by him last year. He now dealt with the history of volcanic action in this country from the close of the Silurian period up to older Tertiary time. The remarkable volcanic outbursts that took place in the great lakes of the Lower Old Red Sandstone were first described. From different vents over central Scotland, piles of lava and tuff, much thicker than the height of Vesuvius, were accumulated, and their remains now form the most conspicuous hill-ranges of that district. It was shown how the subterranean activity gradually lessened and died out, with only a slight revival in the far north during the time of the Upper Old Red Sandstone, and how it broke out again with great vigour at the beginning of the Carboniferous period. Sir Archibald pointed out that the Carboniferous volcanoes belonged to two distinct types and two separate epochs of eruption. The earlier series produced extensive submarine lavasheets, the remains of which now rise as broad terraced plateaux over parts of the lowlands of Scotland. The later series manifested itself chiefly in the formation of numerous cones of ashes, like the *puys* of Auvergne, which were dotted over the lagoons and shallow seas in central Scotland, Derbyshire, Devonshire, and the south-west of Ireland. After a long quiescence, volcanic action once more reappeared in the Permian period; and numerous small vents were opened in Fife and Ayrshire, and far to the south in Devonshire. With these eruptions the long record of Palæozoic volcanic activity closed. No trace has yet been discovered of any volcanic rocks intercalated among the Secondary formations of this country, so that the whole of the vast interval of the Mesozoic period was a prolonged time of quiescence. At last, when the soft clays and sands of the Lower Tertiary deposits of the south-east of England began to be laid down, a stupendous series of fissures was opened across the greater part of Scotland, the north of England, and the north of Ireland. Into these fissures lava rose, forming a notable system of parallel dykes. Along the great hollow from Antrim northwards between the outer Hebrides and the mainland of Scotland, the lava flowed out at the surface and formed the well-known basaltic plateaux of that region.

The address concluded with a summary of the more important facts in British volcanic history bearing on the investigation of the nature of volcanic action. Among these Sir Archibald laid special stress on the evidence for volcanic periods, during each of which there was a gradual change of the internal magma from a basic to an acid condition, and he pointed out how this cycle had been repeated again and again even within the same limited area of eruption. In conclusion, he dwelt on the segregation of minerals in large eruptive masses, and indicated the importance of this fact in the investigation, not only of the constitution and changes of the volcanic magma, but also of the ancient gneisses where what appear to be original structures have not yet been effaced.

## THE CENTENARY OF MURCHISON.

ON February 19, 1792, Roderick Impey Murchison was born at Tarradale, in Ross-shire. By a curious and appropriate coincidence, the anniversary of the Geological Society, the date of which is fixed by statute, fell this year on the 19th of the present month, the hundredth anniversary of the birth of the illustrious author of the "Silurian System." It was a further remarkable conjuncture that the President of the Society,

who had to give the annual address, and take notice of the centenary, was Murchison's literary executor, who was designated by him as the first Professor of Geology in the chair which he founded in the University of Edinburgh, and who now fills the office which he held for so many years—that of Director-General of the Geological Survey. In referring to the doubly interesting features of this anniversary, Sir Archibald Geikie spoke of his great chief with warm admiration. The twenty years which have passed since Murchison's death enable geologists to make a truer estimate of Murchison's real achievements than was possible at the time when his commanding presence filled so prominent a place in the scientific world of his day. They have been able to correct some of his observations and discard some of his generalizations, yet the solid mass of original work done by him remains as a lasting memorial of his genius and industry. In the broad basis of facts, and in the skillful marshalling of these facts in their ordered relations, which distinguished his work among the Silurian rocks, the hand of a consummate master of geological investigation is to be traced. His name has become a household word in geology, and will go down to future ages as that of one of the great pioneers of the science.

Murchison, during all his scientific career, was closely associated with the Geological Society, and took a keen personal interest in its welfare. By his will he left a sum of money to found a medal and fund to be given annually for the reward and encouragement of geological research. This year the medal was awarded to Prof. A. H. Green, of Oxford, and the balance of the fund to Mr. Beeby Thomson. An interesting proof of the affectionate regard entertained for Murchison's memory was afforded by an announcement made by the President. He stated that, a few days before the meeting, an old friend of Murchison, who desired to remain unknown, had come to him and asked to be allowed to offer a slight tribute in remembrance of the man and his work, on his centenary, at the anniversary meeting of the Society. The President was requested to select two geologists (by preference Scotsmen) who were carrying on geological work in Murchison's spirit, and seeking to advance the special branches of research to which he devoted himself, and to present to each of them a cheque for £50, with a framed portrait of the author of the "Silurian System." Sir Archibald Geikie said that the task assigned to him was made comparatively easy by the terms of the generous gift. He had no doubt that the Society would agree with him that there were pre-eminently two Scottish geologists marked out as recipients of this benefaction, who were disciples of Murchison, and were carrying on his work, but with no slavish obedience to the opinions of their master, and who, by their conjoint work, alike with hammer and pen, well deserved this unexpected and appropriate reward—Mr. B. N. Peach and Mr. John Horne. As a touching addition to this pleasing incident, we have since learnt that while the anniversary was being held at Burlington House, the faithful friend who had made this offering to Murchison's memory was engaged in the cemetery at Brompton carefully brushing and washing his tomb. Driving snow was falling at the time from a gloomy sky, in strange contrast with the glow of affection that was piously renovating the inscription that records the name and resting-place of one of the great leaders of modern geology.

## H. W. BATES, THE NATURALIST OF THE AMAZONS.

HENRY WALTER BATES was a native of Leicester, and was engaged in his father's warehouse when, about the year 1845, he made the acquaintance of Alfred Russel Wallace, then English master in the Collegiate



School of that town. Bates was at that time an ardent entomologist, while Wallace was chiefly interested in botany; but the latter at once took up beetle-collecting, and after he left Leicester the following year kept up an entomological correspondence with his friend. Two years later Wallace proposed a joint expedition to Para in order to collect insects and other natural objects, attracted to this locality by the charming account of the country in Mr. W. H. Edwards's "Voyage up the Amazon," a choice confirmed by the late Edward Doubleday, who had just received some new and very beautiful butterflies collected near the city of Para. The two explorers sailed from Liverpool in April 1843, in a barque of 192 tons burthen, one of the very few vessels then trading to Para, and the results of their journey are well known to naturalists. They made joint collections for nearly a year while staying at or near Para, but afterwards found it more convenient to take separate districts and collect independently. Bates spent eleven years in the country, divided pretty equally between the lower and the upper Amazon, and he amassed a wonderful collection of insects. Returning home in 1859, he devoted himself to the study of his collections, and in 1861 read before the Linnean Society his remarkable and epoch-making paper on the Heliconidæ of the Amazon Valley. In this paper, besides making important corrections in the received classification of this group and its allies, he discussed and illustrated in the most careful manner the wonderful facts of "mimicry," and for the first time gave a clear and intelligible explanation of the phenomena, their origin and use, founded on the accepted principles of variation and natural selection. In spite of countless attacks—usually by persons who are more or less ignorant of the facts to be explained—this theory still holds its ground, and notwithstanding the constant accumulation of new facts, and its discussion by new writers, it has never been more clearly or more fully explained than by its original discoverer.

So early as March 1860, Mr. Bates commenced a series of papers for the Entomological Society, under the title of "Contributions to an Insect Fauna of the Amazon Valley." These were at first devoted to the Diurnal Lepidoptera, and in one of them he gave a new classification of the whole group, founded chiefly on the structure of the legs, and leading to the conclusion that the Papilionidæ formed one of the lowest families, while the Nymphalidæ were the highest. This classification has been very generally adopted by entomologists, though there are a few dissentients, who hold that the principle adopted to determine the rank or grade of the respective families is an unsound one. Later on he wrote many papers on the various groups of Longicorn beetles; and finding that his circumstances and the time at his disposal did not allow him to keep up and study two such extensive groups as the Coleoptera and Lepidoptera, he parted with his fine collection of South American butterflies to Messrs. Salvin and Godman, and thereafter devoted himself exclusively to the study of Coleoptera. Later still, he almost confined his attention to the Carabidæ, on which important group he became a recognized authority. His largest works in this direction were his contributions to the "Biologia Centrali-Americana": Vol. I., Part 1 (Geodephaga); Vol. II., Part 2 (Pectinicornia and Lamellicornia); Vol. V. (Longicornia). A supplement to the Geodephaga has since been published in the Transactions of the Entomological Society of London for 1890 and 1891; and a supplement to the Longicornia was in course of preparation, but not finished at the time of his death.

In 1864, he was appointed Assistant Secretary to the Royal Geographical Society, an appointment he held till his death. Besides editing the Journal and Proceedings, and carrying on an immense correspondence with travellers and others in every part of the world, he had practically the entire management of the large establishment of the

Society, and the chief burden of the arrangements for the various meetings, as well as those for the Geographical Section of the British Association. There can be little doubt that it was the confinement and constant strain of this work that weakened his constitution and shortened a valuable life.

When we consider the originality and clearness of exposition in his first great paper on "Mimicry," the accuracy and fulness of knowledge displayed in his systematic and descriptive work, and the power of observation and felicity of style which characterizes "The Naturalist on the Amazons," we cannot but regret that circumstances should have compelled him to devote so much of his time and strength to the mere drudgery of office work, and be thereby to a great extent debarred from devoting himself to those more congenial pursuits in which he had shown himself so well fitted to excel.

His high reputation, both as a hard-working entomologist and philosophic naturalist, led to his being twice chosen President of the Entomological Society of London, first in 1869, and again in 1878; while he was elected a Fellow of the Royal Society in 1881. His somewhat rugged features, quiet, unassuming manners, and thoughtful utterance, must be familiar to all who have attended the evening meetings of the Royal Geographical Society during the last twenty-seven years. Rarely has any Society had a more efficient secretary, who not only carried on its work with accuracy and judgment, but also gained the respect and esteem of all who came in contact with him. He died on February 16, at the age of sixty-seven.

A. R. W.

#### THOMAS ARCHER HIRST.

WE regret to have to record the death of Dr. Hirst, the well-known mathematician. He was the youngest of the three sons of Mr. Thomas Hirst, a wool-stapler, and was born at Heckmondwike, in Yorkshire, on April 22, 1830. In 1844 he became an articulated pupil of Mr. Richard Carter, land agent and surveyor at Halifax; but afterwards he went to Germany, and studied at several Universities, taking the degree of Doctor of Philosophy at Marburg in 1852. His intercourse with Steiner, at Berlin, gave a strong impulse to his studies, and ultimately determined their character. Dr. Hirst on his return to England filled the vacancy at Queenwood College caused by Tyndall's appointment to the Professorship of Natural Philosophy in the Royal Institution. The work at Queenwood occupied most of his time, so that during the three years for which he held the post his only original paper was a note "On the Existence of a Magnetic Medium" (R.S. Proc., vii., 1854).

Towards the close of 1854 he married, and in consequence of his wife's delicate health he passed the winter of 1856-57 in the south of France. During this period he wrote two papers "On Equally Attracting Bodies" (*Phil. Mag.*, xiii., xvi.).<sup>1</sup> On the return journey Mrs. Hirst died (1857) in Paris. After this sad event Dr. Hirst spent six weeks with Prof. Tyndall on the *mer de glace* (cf. "Glaciers of the Alps"); he then returned to Paris, and attended the lectures of Chasles, Liouville, Lamé, and Bertrand. At this time he translated Poisson's famous memoir "On the Percussion of Bodies," and contributed a paper, "Sur le Potentiel d'une Couche infiniment mince comprise entre deux Paraboloïdes Elliptiques" (Liouville, *J. de M.*, ii., 1859).<sup>2</sup> The winter of 1857-58 was spent in Rome. Here was written for Tortolini's *Annali* the memoir "Sur la Courbure d'une Série de Surfaces et de Lignes" (vol. ii., 1859), an abstract of which was subsequently published in the *Quarterly Journal of Mathematics*. In these stirring times Dr.

<sup>1</sup> Cf. Chasles, "Rapport sur les Progrès de la Géométrie," p. 144.

<sup>2</sup> Chasles, "Rapport," p. 303.

Hirst received a cordial welcome from the mathematicians of Southern Italy, and then going north he followed the victorious armies as far as San Martino and Solferino. After the Peace of Villafranca he visited the town of Cremona, and here commenced an acquaintance of life-long duration with Prof. Luigi Cremona.

In 1860, Dr. Hirst took up his residence in London, and for a short time took the advanced mathematical classes in University College School, in consequence of Mr. Cook's illness, and on that gentleman's death he became his successor. This office Dr. Hirst held for five years, and here, with Prof. Key's full concurrence (see Dr. Hirst's preface to Wright's "Elements of Plane Geometry," 1868), he taught geometry to classes of beginners without the use of "Euclid." Subsequently, in 1870, at the request of the Ladies' Educational Association, he gave a course of twenty-four lectures on the subject of geometry to a class of sixty ladies at St. George's Hall. The syllabus of these lectures was printed at the time. He was so well satisfied with the results of his attempt that when, in 1871, the Association for the Improvement of Geometrical Teaching was started, though he had taken no part, directly, in its formation,<sup>1</sup> he at once gave in his adhesion to the movement, and contributed very materially to its success, by his accepting the office of President, and by his doing yeoman's service during his tenure of the office (1871-78). Previous to this Dr. Hirst had, in 1865, been elected Professor of Mathematical Physics in University College. This post he vacated in 1867, when he succeeded Prof. de Morgan in the Chair of Pure Mathematics. It was on January 16, 1865,<sup>2</sup> that the London Mathematical Society was started. Of this Society Dr. Hirst was one of the pillars, and it was in a great measure through his fostering care that it has made the mark it has. He served on the Council from 1865 to November 1885, and for the session 1890-91. He vacated the office of Treasurer when he was elected President for the years 1872-73, 1873-74.

In 1870, Dr. Hirst was appointed to the new office of Assistant Registrar to the University of London, and thereupon resigned his Professorship, and the General Secretaryship of the British Association, which he had held from 1866. In 1873, when the Royal Naval College was founded, he became the Director of Studies, and held the office for ten years, when the precarious state of his health necessitated his retirement, and the passing of several winters abroad. He died on February 16.

In 1861, Dr. Hirst was elected a Fellow of the Royal Society. He was three times a member of the Council of the Society, and twice one of its Vice-Presidents. In 1883 one of the Royal Medals was awarded to him for "his investigations in pure geometry; and, more particularly for his researches into the correlation of two planes and into the complexes generated by them." He was a Fellow of the Royal Astronomical Society, a member of the Physical Society, and of several Continental Societies. He served for some years on the Council of University College, London, and was also a member of the Senate of the University of London.

Dr. Hirst revised the mathematical articles in Brande's "Dictionary of Arts and Sciences," and contributed new ones; and published a translation of Clausius's treatise on "The Mechanical Theory of Heat" (1867).

The following titles of papers may be mentioned:—"On the Volumes of Pedal Surfaces" (Phil. Trans., 1863; *Crelle*, lxii., 1863; and Tortolini, *Annali*, v., 1863). "On the Quadratic Inversion of Plane Curves" (R.S. Proc., 1865; cf. Chasles, "Rapport," p. 167, "Ce mémoire est un travail fort complet"). This was his first *purely* geometrical paper. It was translated by Cremona in the

*Annali di Matematica* (vii., 1865), and a form of it is published in the *Nouvelles Annales* (v., 1866). His remaining papers, mainly contributed to the London Mathematical Society's Proceedings, are:—"On Correlation in Space" (abstract of Presidential Address, 1874, Proc., vi.). "Note on the Correlation of Two Planes" (Proc., viii.). "On Cremonian Congruences" (Proc., xiv.). "On Congruences of the Third Order and Class" (Proc., xvi.). "On Cremonian Congruences contained in Linear Complexes" (Proc., xvii.). "On the Correlation of Two Spaces, each of Three Dimensions" (Proc., xxi.). "On the Complexes generated by Two Correlative Planes" (*Chelini Memorial Volume*, 1881). "Sur la Congruence Roccella" (*Circolo Matematico*, 1886).

#### DR. THOMAS STERRY HUNT.

DR. T. STERRY HUNT, who died at New York on the 12th of this month, in his sixty-sixth year, was widely known from his geological works, especially those relating to chemical geology. For some years past he had been in feeble health, suffering much from heart-disease. Early in this year he was attacked with influenza, from which he seemed to be recovering, but a relapse occurred, from which he failed to rally. Born on September 6, 1826, at Norwich, in Connecticut, he was educated for the medical profession, but in 1845 became assistant to Prof. B. Silliman at Yale College, and was also chemist to the Geological Survey of Vermont. In 1847 he joined the Geological Survey of Canada, under Sir W. Logan, as chemist and mineralogist. From 1856 to 1862 he was Professor of Chemistry at Laval University in Quebec, giving his lectures in French. From 1872 to 1878 he was Professor of Geology at the Massachusetts Institute of Technology. He was elected a Fellow of the Royal Society in 1859, and in 1881 received the honorary degree of LL.D. at Cambridge. Dr. Hunt was one of the founders of the International Geological Congress at Philadelphia, in 1876; he attended the meetings of the Congress at Paris in 1878, Bologna in 1881, Berlin in 1885, and London in 1888, taking an active part in the proceedings of each.

Although by birth a citizen of the United States, he is best known as a Canadian geologist, and, after retiring from the Canadian Survey, he lived for some years in Montreal. But latterly he preferred to consider himself once more as belonging to the United States, and for a few years before his death was a resident in New York.

Dr. Hunt's most important geological work was done in connection with the Geological Survey of Canada, with and under Logan. They led the way in the study of the Archæan rocks of that area, and Hunt gave to them many of the names which have since become well known, and too widely used, in the Archæan controversy. His work on the geology of petroleum was of high value, and he long ago clearly stated generalizations as to its occurrence which later investigations, over wider areas in North America and in other districts, have fully verified. Other important researches, published in the official Reports of the Canadian Survey and elsewhere, related to limestone, dolomite, and gypsum; salt; the chemistry of natural waters; the porosities of rocks; rock-weathering, &c. The well-known "Geology of Canada," issued by Logan in 1863 as Director of the Survey, was in large part written by Hunt, the parts on lithology and on economic geology being almost entirely his; he likewise read the proofs of the whole. He also wrote much on Alpine and Italian geology, and on the classification of the older Palæozoic rocks; in the Cambro-Silurian controversy he was a warm advocate of Sedgwick. The origin of serpentine was also a favourite subject, he stoutly maintaining its aqueous origin. As regards the ancient crystalline rocks generally, he to a large extent

<sup>1</sup> Opening remarks in the Presidential Address, A.I.G.T., First Report, January 17, 1871 (cf. also *NATURE*, vol. ii. pp. 55, 141, 164).

<sup>2</sup> Memoir of Augustus de Morgan, pp. 280-86.

reverted to the Wernerian view, but with some important modifications; these he explained in his "crenitic hypothesis."

Dr. Hunt's earlier papers (1846-49) were wholly on chemistry and mineralogy, and to these subjects he always gave much attention. Some of his latest writings are purely chemical, dealing mainly with the more speculative aspects of that science. Perhaps in these questions, as is certainly the case with many of his theoretical views on geology, Dr. Hunt failed to carry conviction to the minds of his fellow-workers; and it may well be doubted if some of his views on these matters will ultimately add to his scientific reputation. But it would be unjust on this account to ignore the mass of solid work which he accomplished, and the suggestive hints which were scattered throughout his writings.

Dr. Hunt was a man of wide reading and general culture; he possessed a marvellous memory, and great conversational powers. In his company one might for hours forget that science was his special study, so well informed was he in history, literature, and philosophy. His conversation on such subjects possessed an additional interest from his personal acquaintance with many American authors. He was thus an excellent travelling companion, and the writer will not soon forget with what thrilling effect he recited Macaulay's "Horatius," within sight of Cortona and its Etruscan walls.

W. TOPLEY.

#### NOTES.

THE date of the Bakerian Lecture to be delivered before the Royal Society has been altered to March 10. Prof. James Thomson has chosen as his subject "The Trade Winds."

THE general arrangements for the Edinburgh meeting of the British Association have now been completed. The first general meeting will be held on Wednesday, August 3, at 8 p.m., when Dr. William Huggins, F.R.S., will resign the chair, and Sir Archibald Geikie, For. Sec. R.S., Director-General of the Geological Survey of the United Kingdom, President-Elect, will assume the Presidency, and deliver an address. On Thursday evening, August 4, at 8 p.m., there will be a *soirée*; on Friday evening, August 5, at 8.30 p.m., a discourse will be delivered by Prof. A. Milnes Marshall, F.R.S.; on Monday evening, August 8, at 8.30 p.m., a discourse on magnetic induction will be delivered by Prof. J. A. Ewing, F.R.S.; on Tuesday evening, August 9, at 8 p.m., there will be another *soirée*; and on Wednesday, August 10, the concluding general meeting will be held at 2.30 p.m. The different Sections will assemble for the reading and discussion of Reports and other communications on Thursday, August 4, and on the following Friday, Saturday, Monday, and Tuesday. The delegates of Corresponding Societies will meet on Thursday, August 4, and Tuesday, August 9, at 3.30 p.m. Excursions to places of interest in the neighbourhood of Edinburgh will be made on the afternoon of Saturday, August 6, and on Thursday, August 11.

It is proposed that Englishmen shall celebrate the fourth centenary of the discovery of the New World, and do honour to the memory of Columbus, by establishing in Jamaica a marine biological station on the lines of the marine laboratories at Naples and Plymouth. The institution would be called "the Columbus Marine Biological Station." An excellent letter on the subject by Lady Blake appeared in the *Times* on Wednesday. The scheme has been laid before Prof. Huxley, Prof. Ray Lankester, Prof. Flower, Dr. Günther, Dr. Ball, Sir John Lubbock, Mr. Scott, Mr. Sclater, and numerous other scientific men, all of whom warmly approve of it. For the establishment of the laboratory on a sound basis an outlay of £15,000 will be

required. The following have consented to receive subscriptions:—Prof. Ray Lankester, Oxford; Dr. Günther, British Museum (Natural History), Cromwell Road; Dr. Ball, Science and Art Museum, Dublin; the Duchess of St. Albans, Bestwood Lodge, Arnold, Notts.; and Messrs. Coutts and Co., bankers, 59 Strand. The Hon. Walter Rothschild, 148 Piccadilly, has undertaken the duties of honorary secretary.

ON Saturday last a meeting was held in the Combination Room of St. John's College, Cambridge, to discuss a proposal for the provision of a national monument to the late Prof. Adams. The Rev. Dr. Taylor, the Master of the College, presided; and among those present were Dr. Peile (Master of Christ's, and Vice-Chancellor), Dr. Ferris (Master of Caius), Dr. Porter (Master of Peterhouse), Mr. Aldis Wright (Vice-Master of Trinity), Dr. Forsyth, Prof. Hughes, Dr. Hobson, Prof. Thomson, Dr. Glaisher, Dr. Frost, Dr. Sandys, Prof. Mayor, and Sir George G. Stokes, M.P. The Master said that Prof. Adams had memorials in Cambridge in the Adams Prize, and his portraits at that College and at Pembroke. His own work was his monument in the annals of science. They wished to commemorate his name and personality in the eyes of the world in that central sanctuary where, age after age, they commemorated their national types of various kinds of supreme excellence which were the glory of the world. The first suggestion of that came to him from Archdeacon Farrar. The suggestion had been mentioned at a College meeting and by it adopted, and they were met that day to carry it out. He thought the better method would be to form a large and influential committee, containing the most prominent names in mathematics and science, which would enable them to show there was a general feeling in favour of it. Then he thought the request might be made to the Dean and Chapter, on behalf of the Committee, by the Chancellor, the Duke of Devonshire, and in a letter which he had received from the Duke he stated that he should be very glad to give any assistance in his power to carry out the wishes of the Committee. Among those who had agreed to join the Committee were the Astronomer-Royal, the Master of Trinity, Dr. Salmon (Provost of Trinity College, Dublin), the Master of Corpus, Mr. Justice Romer, Prof. Jebb, Mr. Courtney, Lord Rayleigh, Prof. Newton, the Gresham Professor of Astronomy, Prof. Cayley, and Sir Donald Smith (Chancellor of Montreal University), who asked to be allowed to subscribe £100. The following motion, proposed by the Master, seconded by Sir G. G. Stokes, and supported by Dr. Glaisher and Prof. Liveing, was carried unanimously:—"That the late Prof. John Couch Adams, by his discovery of the planet Neptune, and other masterly work, published or unpublished, is entitled to be named with the great astronomers of the world; and that this meeting pledges itself (so far as in it lies) to promote and carry out the scheme for placing a memorial to the late Professor in Westminster Abbey." The following resolutions were also carried:—"That the memorial consist of a bust, with tablet and inscription." "That a Committee be formed (with power to add to their number) to carry out the scheme; that the Master of Pembroke College and Prof. Liveing be the Treasurers, and the Master of Peterhouse, Dr. D. MacAlister, and Dr. Glaisher the Secretaries, and that such and such persons be the Executive Committee." "That any surplus from subscriptions after payment of the necessary expenses to be used in the first instance to defray the cost of presenting copies of the collected papers of Prof. Adams to learned Societies and libraries at home and abroad, and that the remainder (which, if of sufficient amount, shall be constituted a permanent memorial fund) be offered to the Master and Fellows of St. John's College to form an Exhibition or Scholarship fund for the encouragement of the study of mathematics or physics by the undergraduate students of the

College, such fund to be administered in such a manner as the Masters and Fellows may from time to time determine."

At a meeting of the electors to the Lowndean Professorship of Astronomy at Cambridge, held on February 20, Sir Robert S. Ball, Astronomer-Royal for Ireland, was elected to succeed the late Prof. Couch Adams. Sir Robert Ball is fifty-one years of age. He is a native of Dublin, and was educated at Trinity College. When twenty-five years old, he was appointed Lord Rosse's astronomer at Parsonstown. He became Professor of Applied Mathematics and Mechanism at the Royal College of Science of Ireland in 1867, and Professor of Astronomy at the Dublin University, and Astronomer-Royal for Ireland, in 1874. In 1873, he had been made a Fellow of the Royal Society. He has done much by his writings and lectures to create and foster a popular interest in astronomical study. In relation to this appointment we give the following extract from the *Cambridge University Reporter* of February 23:—The Council of the Senate beg leave to report to the Senate as follows: "The arrangement by which 'the superintendence and management of the Observatory' were intrusted to the late Lowndean Professor (Grace, May 2, 1861, Ordinances, p. 239) has now terminated, and as no provision has been made for the future direction of the Observatory, the Council think it desirable that a special Syndicate should be appointed to consider the question." The Council therefore recommend: "That a Syndicate be appointed to consider what provision should be made for the future superintendence and management of the Observatory, and to report to the Senate before the end of the present Lent Term." "That the Vice-Chancellor, Dr. Ferrers, Master of Gonville and Caius College, Prof. Sir G. G. Stokes, Dr. Glaisher, Prof. Liveing, Prof. Thomson, and F. Whitting, M.A., of King's College, be appointed a Syndicate to consider what provision should be made for the future superintendence and management of the Observatory, and to report to the Senate before the end of the present Lent Term."

The Queen has approved the appointment of Dr. Thomas Clifford Allbutt, F.R.S., to be Regius Professor of Physic in the University of Cambridge, in the room of the late Sir George Paget.

MR. J. SCOTT KELTIE has been appointed to succeed the late Mr. H. W. Bates, F.R.S., as Assistant Secretary of the Royal Geographical Society.

At the meeting of the Royal Geographical Society on Monday, Mr. Theodore Bent read before a large audience a paper on his recent exploration among the Zimbabwe and other ruins. The paper was one of great interest. Mr. Bent said that, with his wife and Mr. Robert Swan, he went to Mashonaland primarily to examine the ruins of the Great Zimbabwe. These ruins, so named to distinguish them from the numerous minor Zimbabwes scattered over the country, were situated in south latitude  $20^{\circ} 16' 30''$ , and east longitude  $31^{\circ} 10' 10''$ , at an elevation of 3300 feet above the sea-level, and formed the capital of a long series of such ruins stretching up the whole length of the west side of the Sabæ River. They covered a vast area of ground, and consisted of the large circular building on a gentle rise with a network of inferior buildings extending into the valley below, and the labyrinthine fortress on the hill, about 400 feet above, naturally protected by huge granite boulders and a precipice running round a considerable portion of it. Mr. Bent gave a minute description of the ruins, drawing attention to evidence that their ancient inhabitants must have been given to the grosser forms of native worship. Perhaps the most interesting of their finds in one portion were those in connection with the manufacture of gold. Mr. Bent held that the ruins and the

things in them were not in any way connected with any known African race; the objects of art and the special cult were foreign to the country altogether, where the only recognized form of religion was, and had been since the days when the early Portuguese explorers penetrated into it and El Masoudi wrote, that of ancestor worship. It was also obvious that the ruins formed a garrison for the protection of a gold-producing race in remote antiquity. So we must look around for such a race outside the limits of Africa, and it was in Arabia that we found the object of our search. All ancient authorities speak of Arabian gold in terms of extravagant praise. Little, if any, gold came from Arabia itself; and here in Africa gold was produced in large quantities, both from alluvial and from quartz, from the remotest ages. A cult practised in Arabia in early times was also practised here; hence there was little room for doubt that the builders and workers of the Great Zimbabwe came from the Arabian peninsula. He had no hesitation in assigning this enterprise to Arabian origin, and to a pre-Mahomedan period.

At the anniversary meeting of the Geological Society, held at Burlington House on Friday last, the following officers were elected:—President: W. H. Hudleston, F.R.S. Vice-Presidents: Prof. T. G. Bonney, F.R.S., L. Fletcher, F.R.S., G. J. Hinde, Prof. J. W. Judd, F.R.S. Secretaries: Dr. H. Hicks, F.R.S., J. E. Marr, F.R.S. Foreign Secretary: J. W. Hulke, F.R.S. Treasurer: Prof. T. Wiltshire. The following are the members of the Council: Prof. J. F. Blake, Prof. T. G. Bonney, F.R.S., James W. Davis, R. Etheridge, F.R.S., L. Fletcher, F.R.S., Prof. C. Le Neve Foster, Sir A. Geikie, F.R.S., A. Harker, H. Hicks, F.R.S., G. J. Hinde, W. H. Hudleston, F.R.S., Prof. T. McKenny Hughes, F.R.S., J. W. Hulke, F.R.S., Prof. J. W. Judd, F.R.S., J. E. Marr, F.R.S., H. W. Monckton, Clement Reid, J. J. H. Teall, F.R.S., W. Topley, F.R.S., Prof. T. Wiltshire, Rev. H. H. Winwood, H. Woodward, F.R.S., H. B. Woodward.

In the February number of the *Kew Bulletin* much useful information on sisal hemp (*Agave rigida*, Mill.) is presented. The cultivation of sisal hemp has lately been developed to so remarkable an extent in the Bahamas that hemp-growing has become, for the moment, one of the most prominent of the new industries of the tropics. The *Bulletin* mentions most of the localities where plants of sisal hemp are now found, and the material it has collected will be of great service to all who may think of embarking in a fibre industry at the present time.

AMONG the other contents of the *Kew Bulletin* is an interesting correspondence between Mr. Thiselton-Dyer and the Vice-Chairman of the Middlesex County Council on the question of instruction in horticulture. There is so much vague talk nowadays about technical education that all who wish the words to be used in the right sense will read with pleasure Mr. Thiselton-Dyer's remarks on the proper way of learning the art of cultivating plants. "The cultivation of plants," he says, "is an art which can only be acquired by practice, and therefore, it appears to me, cannot be taught in the lecture-room any more than painting or shoe-making. I know of no royal or theoretical road to the acquisition of a competent or even useful knowledge of the gardener's art except by beginning at the bottom and going through every operation, from the most elementary to the most difficult and refined. If an intelligent young man does that, and keeps his eyes open, he may become a successful gardener. But the mere reading of books and attendance on lectures will never, in my judgment, make anyone even a moderately competent gardener."

A REPORT on the botanical collections made by Dr. Brown Lester, Medical Officer to the Gambia Delimitation Commission,

was published in the *Kew Bulletin* for October and November 1891. A translation of the botanical section of the reports made by the French members of the Commission is given in the February number of the *Bulletin* for the purpose of supplementing Dr. Brown Lester's notes.

APPENDIX II., 1892, of the *Kew Bulletin* contains a list of the new garden plants of the year 1891. The list includes, besides the plants brought into cultivation for the first time in 1891, the most noteworthy of those which have been re-introduced after being lost from cultivation. Other plants in the list have been in gardens for several years, but either were not described or their names had not been authenticated till recently.

IN their Irish Education Bill the Government propose that a large proportion of the funds at their disposal for the improvement of national education in Ireland shall be spent for the benefit of the teachers, who as a class have hitherto been too much neglected. The rest of the amount will be devoted to a capitation grant, and to the freeing of all schools in which the fees do not exceed six shillings a year per child. Attendance at elementary schools, if the Bill becomes law, will be compulsory in Irish towns, but in rural districts it will be open to the people to accept or reject compulsion as they may think fit.

THE National Association for the Promotion of Technical and Secondary Education has issued an appeal to the electors of the London County Council on the subject of technical instruction. As everyone interested in technical education knows, London has devoted to the relief of the rates the whole of its share of the grant obtained from the proceeds of the beer and spirits duties. This has been done in direct opposition to the wish of Parliament; and the Association has no difficulty in showing that the grant will be continued only if it is used for the purposes to which the House of Commons intended it to be applied. It may be hoped that the appeal will be widely read, and that voters will perceive that it deals with a matter by which their interests must sooner or later be vitally affected.

THE principal article of interest to meteorologists in the *American Meteorological Journal* for January is by A. L. Rotch, on the mountain meteorological stations of the United States. At the present time the only stations in operation throughout the year are the Lick Observatory, in California, and the Blue Hill Observatory, in Massachusetts. That on Mount Washington (6280 feet above the sea) was established in 1870, and partially closed in 1887; during the three following years it was opened during the summer months only. At no other station in the world was such severe weather experienced, as the highest wind velocity often occurred with the lowest temperature. During a storm in February 1876, when the temperature fell to  $-50^{\circ}$ , a wind velocity of 184 miles an hour was recorded. In foggy weather the frost formed upon the anemometer cups in such quantity as to break off the arms. The observations at this station have been much lessened in value, owing to their not being published in detail, and to the want of a low-level station for comparison. The Blue Hill Observatory is only 640 feet above the sea, and was opened in 1885. The hourly values for five years have been printed in the Harvard College Observatory. For several years hourly observations of clouds have been made, with a view to benefit weather predictions. The Observatory on Pike's Peak, Colorado (14,134 feet), was built in 1873, and for fifteen years was maintained by the Signal Service. It was closed in 1888, and the observations have been published in the *Annals of the Harvard College Observatory*. The average annual temperature was  $19^{\circ}$ , and the extremes  $64^{\circ}$  and  $-39^{\circ}$ . Pike's Peak is remarkable for its electrical storms. When the air is moist, and

generally when snow is falling, sparks emanate from the fingers of the outstretched hands; but the station was only once struck by lightning. The Lick Observatory is on Mount Hamilton, 4300 feet above the Pacific Ocean, which is plainly visible from the summit. Fragmentary observations have been made at various other stations, the most important of which were those by Prof. Langley, on Mount Whitney, California, in 1881, which have served to change the theory of the nature of the heat received from the sun, and to show that the sun is much hotter than had been supposed. The article is accompanied by photographic illustrations of several of the stations.

ELECTRICITY is being applied to a novel use in the U.S. Navy. Four electric fans have been placed by the Crocker Wheeler Company in the turrets of the powerful iron vessel *Miantonomah*, the intention being that they shall blow away the smoke from the guns.

AN interesting compound of carbon with the metal barium, possessing the composition  $C_2Ba$ , is described by M. Maquenne in the current number of the *Comptes rendus*. It may be considered, perhaps, as an acetylide of barium—that is, a compound formed by the replacement of the hydrogen of acetylene,  $C_2H_2$ , by metallic barium. For immediately it is brought in contact with water pure acetylene gas is evolved with great rapidity. M. Maquenne has obtained the new substance by the direct action of metallic barium, employed in the form of an amalgam consisting of one part barium and four parts mercury, upon powdered retort-charcoal. Upon distilling such a mixture in a current of hydrogen, when the mercury had been expelled and the temperature attained redness, an energetic reaction was found to occur between the barium and the carbon, with production of the new carbide or acetylide. The hydrogen took no part in the reaction, and M. Maquenne has subsequently found that it may be replaced by nitrogen; the latter, however, being less advantageous, inasmuch as the carbide produced is then admixed with more or less cyanide. The new substance, as obtained when hydrogen is employed to furnish the atmosphere, consists of a grey, friable mass, which remains quite unaltered when heated to bright redness. The moment, however, it is thrown into cold water it is decomposed, with a rapid effervescence of a gas which possesses the odour of acetylene, burns in the air with a luminous flame, precipitates a red substance resembling acetylide of copper from an ammoniacal solution of cuprous chloride, and, in short, possesses all the properties of acetylene. M. Maquenne adds that the acetylene thus obtained is remarkably pure. The reaction with water may be expressed by the equation—

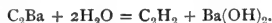

Barium acetylide would appear to be analogous to the compounds obtained by M. Berthelot by heating the metals of the alkalis in a current of acetylene, and also to the acetylide of calcium prepared by Wöhler. The direct formation of this substance from barium and carbon, together with its reaction with water, afford another mode of synthesizing acetylene, which M. Maquenne considers to be of interest from the point of view of the formation of the natural hydrocarbons. He considers it probable that other metals possess this same property of forming acetylides under the influence of high temperatures. If, therefore, as M. Berthelot has attempted to show, it is a fact that acetylene forms the primary material, or starting-point, for the formation of other hydrocarbons, it is quite possible that such compounds of metals with carbon, upon coming in contact with water under conditions of more or less pressure, may give rise to the production of the immense stores of natural hydrocarbons, such as those which exist in the petroleum wells of Russia and the New World.

THE additions to the Zoological Society's Gardens during the past week include a Sykes's Monkey (*Cercopithecus albicularis* ?) from East Africa, presented by Mr. G. N. Wylie; a Beatrix Antelope (*Oryx beatrix* ?), an Indian Gazelle (*Gazella bennetti*) from Arabia, presented by Lieut.-Colonel Talbot; a Goshawk (*Astur palumbarius*), European, presented by Captain Noble; a Common Quail (*Coturnix communis*), European, presented by W. K. Purnell; a Hybrid Goose (between *Anser cinereus* and *A. brachyrhynchus*), captured in Holland, presented by Mr. F. E. Blaauw, C.M.Z.S.; a Gould's Monitor (*Varanus gouldi*), a Stump-tailed Lizard (*Trachydosaurus rugosus*) from New South Wales, presented by Mr. T. Hellberg; a Chub (*Leuciscus cephalus*), British fresh waters, presented by Mr. H. E. Young; two Yaks (*Poephagus grunniens* ♂ ♀) from Tibet, three Gigantic Salamanders (*Megalobatrachus maximus*) from Japan, deposited; and an Azara's Agouti (*Dasyprocta azarae*), a Pucheran's Hawk (*Asturina pucherani*), a Sulphury Tyrant (*Pitangus sulphuratus*), two Short-winged Tyrants (*Machetornis rixosa*) a Brown Milvago (*Milvago chimango*), an Orange-billed Coot (*Fulica leucoptera*), a Cayenne Lapwing (*Vanellus cayennensis*), six Rosy-billed Ducks (*Metopiana peposaca* ♂ ♂ 3 ♀) from South America, purchased; an American Bison (*Bison americanus* ♂) from North America, received in exchange; a Gayal (*Bibos frontalis* ♀), born in the Gardens.

#### OUR ASTRONOMICAL COLUMN.

THE SOLAR DISTURBANCE OF 1891, JUNE 17.—In the October number of the *Observatory* Mr. H. H. Turner publishes an article on the luminous outburst on the sun observed by M. Trouvelot on June 17, and recorded in these columns on July 9. The disturbance was of such an unusual character that M. Trouvelot hazarded the suggestion that it was possibly accompanied by perturbations of the magnetic elements. Mr. Whipple was good enough to look over the Kew curves to see if they showed any such variations, and a negative result was obtained. Mr. Turner, however, after an examination of the Greenwich records has succeeded in finding "a very minute, though unmistakable, disturbance at almost precisely the time noted by Trouvelot. . . . The disturbance is smaller than many others on the same day, although the day itself was very quiet: but it differs from others in its abruptness, which is clearly shown in all three curves. The change in declination is only about 1', and in H.F. 0.0005 of the whole H.F." Diagrams illustrating these fluctuations accompanied Mr. Turner's paper. It seemed strange that the Kew and the Greenwich records should differ in their indications, so a further enquiry was sent to Mr. Whipple, who replied as follows:—"I have again referred to the curves of June 17, 1891, and fail to find any trace of what can be by any means be termed to be a magnetic disturbance at the time in question—accepting Sabine's interpretation of a magnetic disturbance (see Phil. Trans., vol. cliii., p. 274), and so avoiding loose expressions. According to the *Observatory*, October 1891, Father Sidgreaves is quite of our opinion as to the case in point." The evidence in favour of a magnetic disturbance simultaneously with Trouvelot's observation is thus not very strong.

PHOTOGRAPHY OF SOLAR PROMINENCES.—In a communication to the Paris Academy on February 8, M. Deslandres described some new results obtained by him in the photography of solar prominences. The object of the research was to photograph the spectra of prominences further into the ultra-violet than had previously been done. In July of last year, M. Deslandres, following Prof. Hale, succeeded in photographing the spectra to  $\lambda$  350. He has now been able to obtain negatives upon which the spectrum extends from  $\lambda$  410 to  $\lambda$  350. In order to obtain this result, a siderostat with a mirror 8 inches in diameter has been employed to project the sun's image, a Rowland grating has been used to produce the spectra, and the lenses of the observing telescope have been made of quartz. The photographs show eight bright lines of the ultra-violet hydrogen series, and it is believed that observations made from an elevated station would lead to the detection of the remaining two. The line a little more refrangible than hydrogen  $\alpha$  ( $\lambda$  388),

is also recorded upon the plates. Photographs have been taken of the spectra of spots and faculae. The calcium lines at H and K often appear bright upon them, and are always stronger than the hydrogen lines. But no new facts appear to have been discovered in this direction of work.

ON THE VARIATION OF LATITUDE.—Dr. S. C. Chandler has published a series of papers on the variation of latitude, in the *Astronomical Journal* from No. 248 to No. 251. The general result of a wide discussion indicates a revolution of the earth's axis of inertia about that of rotation from west to east, with a radius of 30 feet measured at the earth's surface, in a period of 427 days.

#### NON-EUCLIDIAN GEOMETRY.<sup>1</sup>

EVERY conclusion supposes premisses; these premisses themselves are either self-evident and have no need of demonstration, or can only be established by assuming other propositions; and as we cannot continue this process to infinity, every deductive science, and especially geometry, must rest on a certain number of axioms which cannot be demonstrated. All treatises on geometry therefore commence with the enunciation of these axioms. But a distinction must be made between them: some—such as this for example, "Two quantities that are equal to a third quantity are equal to one another"—are not geometrical propositions, but are analytical ones. I regard them as analytical *a priori* judgments, and as such I will not discuss them. But I must insist on other axioms which are special to geometry. Text-books for the most part state them very explicitly:—

- (1) Only one straight line can be drawn between two points.
- (2) A straight line is the shortest distance between two points.
- (3) Only one straight line can be drawn through a point parallel to a given straight line.

Although the demonstration of the second of these axioms is generally dispensed with, it would be possible to deduce it from the other two, and from those, of which the number is more considerable, that we admit explicitly without stating them, as I shall explain in the sequel.

Efforts have also for a long time been made without success to demonstrate the third axiom, known under the name of the *postulatum d'Euclide*. The amount of trouble that has been taken in that chimerical hope is truly beyond imagination. Finally, at the commencement of the century, and almost simultaneously, Lowatchewski and Bolyai, two men of science, a Russian and Hungarian respectively, established, in an irrefutable manner, that such a demonstration was impossible; they have very nearly rid us of the inventors of geometries without postulates: since their time the Academy of Sciences only receives annually one or two new demonstrations.

The question was still not settled; soon a great step was made by the publication of the celebrated memoir of Riemann, entitled "Ueber die Hypothesen welche der Geometrie zum Grunde liegen." This small treatise has inspired the majority of recent works, of which I will make mention subsequently, and among which must be mentioned those of Beltrami and Helmholtz.

The *Geometry of Lowatchewski*.—If it were possible to deduce the *postulatum d'Euclide* from the other axioms, it would evidently happen that in denying the postulate and admitting the axioms, we should be led to contradictory results; it would then be impossible to base a coherent geometry on such premisses.

But this is precisely what Lowatchewski has done. He supposes in the first place that—

"Several straight lines can be drawn through a point parallel to a given straight line."

And he moreover retains all the other axioms of Euclid. From these hypotheses he deduces a series of theorems among which it is impossible to detect any contradiction, and he constructs a geometry the faultless logic of which is not inferior to that of the Euclidian geometry.

The theorems are, certainly, very different from those to which we are accustomed, and they disconcert us a little at first.

Thus, the sum of the angles of a triangle is always less than two right angles; and the difference between this sum and two right angles is proportional to the surface of the triangle.

<sup>1</sup> Translation of an article that appeared in the *Revue Générale des Sciences*, No. 23, by M. H. Poincaré.

It is impossible to construct a figure similar to a given figure, but of different dimensions.

If a circle be divided into  $n$  equal parts, and tangents be drawn to the points of division, these  $n$  tangents will meet and form a polygon, provided that the radius of the circle be small enough; but if this radius is sufficiently large, they will not meet. It is useless to multiply these examples; the propositions of Lowatchewski have no longer any connection with those of Euclid, but they are not less logically connected together.

*The Geometry of Riemann.*—Let us imagine a world peopled only with beings deprived of thickness; and let us suppose that these animals, "infinitely flat," are all in one plane, and are not able to get out of it. Let us admit, further, that this world is removed sufficiently from others to be free from their influence. As we are making these assumptions, we may as well endow these beings both with reasoning powers and the capacity of founding a geometry. In this case they would certainly attribute to space only two dimensions.

But let us suppose, however, that these imaginary animals, all still devoid of thickness, have the form of a portion of a spherical figure, and not of a plane one, and are all on one and the same sphere without being able to leave it. What geometry would they construct? It is clear at once that they would only attribute to space two dimensions: that which will play for them the part of the straight line will be the shortest distance between two points on the sphere—that is to say, an arc of a great circle; in a word, their geometry would be spherical geometry.

What they will call space will be this sphere which they cannot leave, and on which occur all the phenomena of which they can have any knowledge. Their space then will be *without limits*, since on a sphere one can always go forward, without ever coming to an end, and nevertheless it will be *finite*—one will never find the limit, but one can make the circuit of it.

In fact, the geometry of Riemann is spherical geometry extended to three dimensions. To construct it, the German mathematician had to throw overboard not only the postulates of Euclid, but even the first axiom: *Only one straight line can be drawn between two points.*

On a sphere only one great circle in general can be drawn through two given points (which, as we have just seen, would play the part of the straight line to our imaginary beings); but to this there is an exception; for, if the two given points are diametrically opposed, an infinite number of great circles can be made to pass through them.

In the same way, in the geometry of Riemann, only one straight line in general can be drawn between two points; but there are exceptional cases where an infinite number of straight lines can be drawn between them.

There is a kind of opposition between the geometry of Riemann and that of Lowatchewski.

- Thus, the sum of the angles of a triangle is—
- Equal to two right angles in Euclid's geometry.
- Less than two right angles in that of Lowatchewski.
- Greater than two right angles in that of Riemann.
- The number of parallels that can be drawn to a given straight line through a given point is equal—
- To one in the geometry of Euclid.
- To zero in that of Riemann.
- To infinity in that of Lowatchewski.

Let us add that the space of Riemann is finite although without limit, in the sense already given to these two words.

*Surfaces of Constant Curvature.*—There was, however, one possible objection. The theorems of Lowatchewski and of Riemann present no contradiction, but, however numerous the consequences which these two geometries have drawn from their hypotheses, they were compelled to stop before they had exhausted all of them, for the number would be infinite: who can say, therefore, that, if they had carried their deductions further, they would not finally have found such contradictions?

This difficulty does not exist for the geometry of Riemann, provided that it is limited to two dimensions; for, in fact, the geometry of Riemann for two dimensions does not differ, as we have seen, from spherical geometry, which is only a branch of ordinary geometry, and consequently outside all discussion.

M. Beltrami, in considering in the same way the two-dimensional geometry of Lowatchewski to be only a branch of ordinary geometry, has equally refuted the objection in this case.

This he has done this in the following manner:—Consider on

a surface any figure. Imagine this figure, traced on a flexible and inextensible cloth, to be laid on this surface, in such a way that when the cloth is moved and changes its shape, the various lines of this figure can change form without altering their length. In general this flexible and inextensible figure cannot leave its place without quitting the surface; but there are certain particular surfaces for which a similar movement would be possible; these are the surfaces with constant curvature.

If we resume the comparison that we previously made, and imagine beings without thickness living on one of these surfaces, they will regard the movement of a figure all of whose lines preserve a constant length as possible. A like movement, on the other hand, would appear absurd to animals without thickness living on a surface whose curvature was variable.

These surfaces of constant curvature are of two kinds:—Some are of *positive curvature*, and can be so deformed as to be laid on a sphere. The geometry of these surfaces becomes then spherical geometry, which is that of Riemann.

Others are of *negative curvature*. M. Beltrami has shown that the geometry of these surfaces is none other than that of Lowatchewski. The two-dimensional geometries of Riemann and Lowatchewski are thus found to be re-attached to Euclidian geometry.

*Interpretation of Non-Euclidian Geometries.*—Thus the objection disappears as regards geometries of two dimensions.

It would be easy to extend M. Beltrami's reasoning to geometries of three dimensions. The minds which space of four dimensions does not repel will see here no difficulty; but they are few. I prefer, then, to proceed otherwise.

Let us consider a particular plane that we will call fundamental, and construct a kind of dictionary, making a double series of words, written in the two columns, correspond each to each, in the same way that the words of two languages, having the same signification correspond in ordinary dictionaries:—

Space... ..	Portion of space situated above the fundamental plane.
Plane ... ..	Sphere cutting orthogonally the fundamental plane.
Right line... ..	Circle cutting orthogonally the fundamental plane.
Sphere ... ..	Sphere.
Circle ... ..	Circle.
Angle ... ..	Angle.
Distance between two points ... ..	} Logarithm of the anharmonic ratio of these two points and the intersections of the fundamental plane with a circle passing through these two points and cutting it orthogonally.
&c.,	

Let us take, then, the theorems of Lowatchewski, and translate them by means of this dictionary, as we should translate a German text with the aid of a German-French dictionary. *We shall obtain then the theorems of ordinary geometry.*

For example, this theorem of Lowatchewski—"The sum of the angles of a triangle is less than two right angles"—is translated thus: "If a curvilinear triangle has for its sides the arcs of a circle which if prolonged would cut orthogonally the fundamental plane, the sum of the angles of this curvilinear triangle will be less than two right angles." Thus, however far one pushes the results of the hypotheses of Lowatchewski, one will never be led to a contradiction. Indeed, if two of Lowatchewski's theorems were contradictory, the translations of these two theorems, made with the help of our dictionary, would also be contradictory; but these translations are theorems of ordinary geometry, and everyone agrees that ordinary geometry is free from contradictions. Whence comes this certainty, and is it justified? This is a question that I cannot treat here, but which is very interesting, and, as I believe, soluble. The objection that I have formulated above no longer then exists.

But this is not all. The geometry of Lowatchewski, susceptible of a concrete interpretation, ceases to be a frivolous logical exercise, and is capable of application: I have not the time to mention here either these applications or the use that M. Klein and myself had made of them for the integration of linear equations.

This interpretation, moreover, is not unique, and one could construct several dictionaries analogous to that given above, and by which we could by a simple "translation" transform the theorems of Lowatchewski into theorems of ordinary geometry

*Implicit Axioms.*—Are then the axioms explicitly enunciated in treatises the only foundations of geometry? One can be assured to the contrary when one sees that, after having successively abandoned them, there still remain some propositions common to theorems of Euclid, Lowatchewski, and Riemann. These propositions ought to rest on some premisses, as geometers admit, although they do not state them. It is interesting to try to liberate them from classical demonstrations.

Stuart Mill has made the assertion that every definition contains an axiom, since, in defining it, the existence of the object defined is implicitly affirmed. This is going too far: it is seldom that one gives a definition in mathematics without following it by the demonstration of the existence of the object defined, and when it is omitted, it is generally because the reader can easily supply it. It must not be forgotten that the word existence has not the same sense when it is the question of a mathematical creation as when we have to do with a material object. A mathematical creation exists, provided that its definition involves no contradiction either in itself or with the properties previously admitted.

But if Stuart Mill's remark cannot be applied to all definitions, it is none the less true for some of them.

A plane is sometimes defined in the following manner:—The plane is a surface such that the straight line which joins any two points in it lies altogether in the surface.

This definition manifestly hides a new axiom: we could, it is true, alter it, and that would be better, but then it would be necessary to enunciate the axiom more explicitly.

Other definitions give place to reflections no less important.

Such is, for example, that of the equality of two figures: two figures are equal when they can be superposed; to superpose them it is necessary to displace one until it coincides with the other; but how must it be displaced? If we ask, we should be answered that it ought to be done without changing its shape, and in the manner of an invariable solid. The "reasoning in a circle" would then be evident.

In truth, this definition implies nothing. It would have no meaning for a being who lived in a world where there were only fluids. If it seems clear to us, it is that we are accustomed to the properties of natural solids that do not differ greatly from those of ideal solids whose dimensions are all invariable.

Meanwhile, however imperfect it may be, this definition implies an axiom.

The possibility of the movement of an invariable figure is not a truth evident by itself, or at least it is only one in the same way as the *postulatum* of Euclid, and not as an analytical *a priori* judgment would be.

Moreover, in studying the definitions and the demonstrations of geometry, we see that one is obliged to admit, without demonstrating it, not only the possibility of this movement, but even some of its properties.

This results, first of all, from the definition of the straight line. Many defective definitions have been given, but the true one is that which is understood in all the demonstrations where the straight line is in question:

"It may happen that the movement of a constant figure is such that all points of a line belonging to this figure remain immovable while all the points situated outside this line are displaced. Such a line will be called a straight line."

We have in this enunciation purposely separated the definition from the axiom that it implies.

Several proofs, such as those relating to the equality of triangles which depend on the possibility of letting fall a perpendicular from a point on a line, assume propositions that are not enunciated, since we must admit that it is possible to carry a figure from one place to another in a certain manner.

*The Fourth Geometry.*—Among these implicit axioms, there is one which seems to me worth mentioning, not only because it has given rise to a recent discussion,<sup>1</sup> but because in abandoning it, one can construct a fourth geometry, as coherent as those of Euclid, Lowatchewski, and Riemann.

To demonstrate that we can always raise from a point, A, a perpendicular to a straight line, AB, a straight line, AC, is considered movable round the point A, and in the first instance coinciding with the fixed line AB; and it is made to turn round the point A until it lies in the prolongation of AB.

<sup>1</sup> See MM. Renouvier, Léchals, Calinon, *Revue Philosophique*, June 1889; *Critique Philosophique*, September 30 and November 30, 1889; *Revue Philosophique*, 1890, p. 158. See especially the discussion on the "postulate of perpendicularity."

We thus assume two propositions: first, that such a rotation is possible, and then that it can be continued until the two lines are in one straight line.

If the first point be admitted, and the second rejected, we are led to a series of theorems still more curious than those of Lowatchewski and Riemann, but equally free from contradiction.

I will quote only one of them, and that not the most singular: *A true straight line can be perpendicular to itself.*

*Theorem of Lie.*—The number of implicit axioms introduced in classical demonstrations is greater than it need be, and it would be interesting to reduce them to a minimum. We can ask ourselves, in the first place, if this reduction is possible, if the number of necessary axioms, and imaginable geometries is not infinite.

M. Sophus Lie's theorem dominates all this discussion: it can be thus stated:—

Let us suppose that the following premisses are admitted:—

- (1) Space has  $n$  dimensions.
- (2) The movement of an invariable figure is possible.
- (3) To determine the position of this figure in space,  $p$  conditions are necessary.

*The number of geometries compatible with these premisses will be limited.*

I can even add that, if  $n$  be given, a higher limit to  $p$  can be assigned.

If, then, the possibility of movement be admitted, only a finite number (and that a restricted one) of geometries can be invented.

*The Geometries of Riemann.*—However, this result seems to be contradicted by Riemann, because this investigator constructed an infinite number of different geometries, and the one which generally bears his name is only a particular case.

Everything depends, he says, on the way in which we define the length of a curve. But there are an infinite number of ways of defining this length, and each of these can become the starting point of a new geometry.

That is perfectly true; but most of these definitions are incompatible with the movement of an invariable figure, which is supposed possible in Lie's theorem. These geometries of Riemann, so interesting on many grounds, can only then remain purely analytical, and do not lend themselves to demonstrations analogous to those of Euclid.

*The Nature of Axioms.*—Most mathematicians regard the geometry of Lowatchewski only as a simple logical curiosity; some of them, however, have gone further. Since several geometries are possible, is it certain that ours is the true one? Experience, doubtless, teaches us that the sum of the angles of a triangle is equal to two right angles; but this is only because we operate on too small triangles; the difference, according to Lowatchewski, is proportional to the surface of the triangle; will it not become sensible if we work with larger triangles, or if our means of measurement grow more accurate? Euclidian geometry would only then be a provisional geometry.

To discuss this question, we ought in the first instance to inquire into the nature of geometrical axioms.

Are they synthetical conclusions *a priori*, as Kant used to say?

They would appeal to us then with such force, that we could not conceive the contrary proposition, nor construct on it a theoretical edifice. There could not be a non-Euclidian geometry.

To convince oneself of it, let us take a true synthetical *a priori* conclusion; for example, the following:—

*If an infinite series of positive whole numbers be taken, all different from each other, there will always be one number that is smaller than all the others.*

Or this other, which is equivalent to it:—

*If a theorem be true for the number 1, and if it has been shown to be true for  $n + 1$ , provided that it is true for  $n$ , then it will be true for all positive whole numbers.*

Let us next try to free ourselves from this conclusion, and, denying these propositions, to invent a false arithmetic analogous to the non-Euclidian geometry. We find that we cannot; we shall be even tempted in the first instance to regard these conclusions as the results of analysis.

Moreover, let us resume our idea of the indefinitely thin animals: surely we can scarcely admit that these beings, if they have minds like ours, would adopt Euclidian geometry, which would be contrary to all their experience.

Ought we, then, to conclude that the axioms of geometry are



experimental truths? But we do not experiment on straight lines or ideal circles; only material objects can be dealt with. On what would depend, then, the experiments which would serve to found a geometry? The answer is easy.

We have seen above that one argues constantly as if geometrical figures behaved like solids. That which geometry would borrow from experience is therefore the properties of these bodies.

But a difficulty exists, and it cannot be overcome. If geometry were an experimental science, it would not be an exact science—it would be liable to a continual revision. What do I say? It would from to-day be convicted of error, since we know that a rigorously invariable solid does not exist.

*Geometrical axioms, therefore, are neither synthetic a priori conclusions nor experimental facts.*

They are *conventions*: our choice, amongst all possible conventions, is *guided* by experimental facts; but it remains *free*, and is only limited by the necessity of avoiding all contradiction. It is thus that the postulates can remain rigorously true, even when the experimental laws which have determined their adoption are only approximate.

In other words, *axioms of geometry* (I do not speak of those of arithmetic) are only definitions in disguise.

This being so, what ought one to think of this question: Is the Euclidian geometry true?

The question is nonsense.

One might just as well ask whether the metric system is true and the old measures false; whether Cartesian co-ordinates are true and polar co-ordinates false; whether one geometry cannot be more true than another—it can only be more convenient.

Now, Euclidian geometry is, and will remain, the most convenient:—

(1) Because it is the simplest; and it is not so simply on account of our habits of thought, or any kind of direct intuition which we may have of Euclidian space; it is the most simple in itself in the same way as a polynomial of the first order is simpler than one of the second.

(2) Because it agrees sufficiently well with the properties of natural solids, those bodies which come nearer to our members and our eye, and with which we make our instruments of measurement.

*Geometry and Astronomy.*—The above question has also been stated in another way. If the geometry of Lowatchewski is true, the parallax of a very distant star would be finite; if that of Riemann be true, it would be negative. Here we have results which seem subject to experience, and it has been hoped that astronomical observations would have been able to decide between the three geometries.

But what one calls a straight line in astronomy is simply the trajectory of a ray of light. If then, as is impossible, we had discovered negative parallaxes, or shown that all parallaxes are greater up to a certain limit, we should have the choice between two conclusions:—

We could renounce Euclidian geometry, or modify the laws of optics, and admit that light is not propagated strictly in straight lines.

It is useless to add that everyone would regard the latter solution as the more advantageous.

Euclidian geometry, then, has nothing to fear from new experiments.

Let me be pardoned for stating a little paradox in conclusion:—

The beings which had minds like ours, and who had the same senses as we have, but who had not received any previous education, might receive conventionally from an exterior world choices of impressions such that they would be led to construct a geometry different from that of Euclid, and to localize the phenomena of this exterior world in a non-Euclidian space, or even in a space of four dimensions.

For us, whose education has been formed by our real world, if we were suddenly transported in this new one, we should not have any difficulty in referring the phenomena to our Euclidian space.

Anyone who should dedicate his life to it could, perhaps, eventually imagine the fourth dimension.

I fear that in the last few lines I have not been very clear. I can only be so by introducing new developments; but I have already been too long, and those whom these explanations might interest have read their Helmholtz.

Desiring to be brief, I have affirmed more than I have proved: the reader must pardon me for this. So much has been written on this subject, so many different opinions have been put forward, that the discussion of them would fill a volume.

W. J. L.

## SOCIETIES AND ACADEMIES.

LONDON.

**Royal Society, February 11.**—"The *Rôle* played by Sugar in the Animal Economy: Preliminary Note on the Behaviour of Sugar in Blood." By Vaughan Harley, M.D.

This communication was to show that the causes why the whole amount of added sugar can seldom be recovered from blood are threefold. Firstly, the imperfections in the as yet known methods of analysis. Secondly, the different ways in which the albumens of the blood behave themselves while coagulating; some coagulating in the form of firm clots, which retain the saccharine matter in their interstices, rendering it impossible to extract all the sugar from them by washing; others separating as loose, flocculent curds, from which the sugar can be regained with comparative facility. While, thirdly, as bacteria were distinctly ascertained to have nothing to do in the matter, and yet the loss of the sugar added to the blood is in every instance distinctly progressive—according to the period of time the sugar is left in contact with the blood before the analysis is begun—Dr. Vaughan Harley considered himself justified in saying that there must exist in the normal blood itself a sugar-transforming agent. This he described as an enzyme; but refrained from going into any further particulars regarding it until his researches upon the subject are more advanced.

He gave tables of the results of his experiments, and compared them with those recently published by Schenk, Rohmann, and Seegen; showing that while the percentages of the sugar regained by the first observer ranged from 20 to 55 per cent., and those recovered by the two last experimenters fluctuated between 80 and 96 per cent., in his three different series of experiments, where different methods of analysis were employed, the percentages of the added sugar regained ranged respectively between 85 and 100; 92.9 and 99.3; and 94.7 and 99.9 per cent.

**Mathematical Society, February 11.**—Prof. Greenhill, F.R.S., President, in the chair.—The following communications were made:—On the logical foundations of applied mathematical sciences, by Mr. Dixon. He maintained the importance of distinguishing in all sciences between what is dependent on verbal conventions and what is not. He thus distinguished between that part of the meaning of a term which is laid down as its definition, and the part which remains to be discovered as a consequence of the definition. So also sciences might be divided into purely symbolic sciences, which being based on definitions alone conveyed no real information; subjective sciences, which deal with concepts and objective sciences, which deal with actual things. He then stated the conditions under which a set of assertions might be arbitrarily laid down as the definition of a term; and applied these conditions to show that Newton's three laws of motion could be regarded as a definition of the term force, that if this was done there could no longer be any discussion as to whether or not force alone is sufficient to account for the movements of matter. The anomaly that we are apparently able to determine directions absolutely, though we can determine positions only relatively, was explained, and a formal proof of all the elementary theorems of mechanics, including the principle of virtual work, might be deduced.—Note on the inadmissibility of the usual reasoning by which it appears that the limiting value of the ratio of two infinite functions is the same as the ratio of their first derived, with instances in which the result obtained by it is erroneous, by Mr. Culverwell.—On Saint Venant's theory of the torsion of prisms, by Mr. A. B. Basset, F.R.S.

DUBLIN

**Royal Society, January 20.**—Prof. W. N. Hartley, F.R.S., in the chair.—Reports on the zoological collections made by Prof. Haddon in Torres Straits, 1888-89: the *Hydrocorallina*, by S. J. Hickson. The specimens described are a female stock of *Stylaster gracilis*, *Distichopora violacea*, and *Millepora Murrayi*. Some of the smaller colonies of *Distichopora* are bright orange in colour, others vandyke brown, and the larger ones are deep purple with pale yellowish tips. The author

believes that the differences in colour mean a difference in age and sexual condition. The smallest colonies are not sexually mature, the brownish have male ampullae, and the oldest stocks are violet in colour, and are apparently female. In any case, the colour of *Distichopora* can no longer be regarded as the principal character for specific definition.—Sir Howard Grubb, F.R.S., exhibited and described a 4-inch equatorially-mounted refracting telescope of novel construction, in which the right ascension and declination circles were situated at the eye end of the telescope itself, instead of, as usual, on the polar and declination axes; thereby rendering the working of the instrument most convenient for the observer. The circles at the eye end of the telescope are connected by gearing to the polar and declination axes; but Sir H. Grubb described the method by which the "loss of time," and other errors, consequent on gearing, were almost totally eliminated, and the readings rendered quite sufficiently accurate for all ordinary purposes to which such a telescope would be put.—The first part of a memoir on the fossil fishes of the Coal-measures of the British Islands, by Mr. James W. Davis, was communicated by the Honorary Secretaries of the Society.

## PARIS.

**Academy of Sciences, February 15.**—M. d'Abbadie in the chair.—On a new method of organic analysis, by M. Berthelot. The method consists in heating the compound in oxygen under a pressure of 25 atmospheres in a calorimetric bomb. Combustion is total and instantaneous, and therefore differs from that which appertains to the use of copper oxide.—On the employment of compressed oxygen in the calorimetric bomb, by the same author.—Action of alkaline metals on boric acid: critical study of the processes used in the preparation of amorphous boron, by M. Henri Moissan. The general result of the investigation is that when an alkaline metal acts on boric acid the reaction that occurs is accompanied with considerable heat, and, on account of the elevation of temperature, the greatest part of the boron set free combines with the excess of alkali, and with parts of the metal vessel used for the experiment. When this is afterwards washed out with water and hydrochloric acid, a mixture of boron, boride of sodium, boride of iron, boron hydride, nitride of boron, and hydrated boric acid is obtained after desiccation. This mixture is said to have the same composition as the substance which has hitherto been regarded as amorphous boron. M. Moissan will describe a method of preparing amorphous boron in a future paper.—Experimental researches on the transmissibility of cancer, by M. Simon Duplay.—The temporary star in Auriga, by M. G. Rayet. On February 10 and 11 the star appeared to M. Rayet to be orange-yellow or pale yellow. Its spectrum was examined by means of the 14-inch equatorial fitted with a spectroscope. It appeared to be continuous, the red and violet portions being comparatively bright. Four bright lines were seen in the green, and their wave-lengths were determined as 518, 501, 493, and 487.—Extension of Lagrange's equations to the case of sliding friction, by M. Paul Appell.—On the distribution of prime numbers, by M. Phragmen.—On the measure of high temperatures; reply to M. H. Becquerel, by M. H. Le Chatelier.—Remarks on the surface tension of liquid metals; a reply to a note by M. Pellat, by M. Gouy.—Variation, with temperature, of the dielectric constant of liquids, by M. D. Negreano. Experiments on benzene, toluene, and xylene, between 5° and 45° C., indicate that the dielectric constant diminishes with increase of temperature.—On the influence exercised on electro-magnetic resonance by an unsymmetrical arrangement of the long circuit along which the waves are propagated, by MM. Blondlot and M. Dufour. The experiments show that the wave-length, measured by means of a resonator, is independent of the dissymmetry of the two wires which transmit the electro-magnetic undulations.—The propagation of electric waves studied by a telephonic method, by M. R. Colson.—Magnetic perturbation of February 13 and 14, by M. Moureaux. The disturbance was first indicated on the magnetograph of the Parc Saint-Maur Observatory at 5h. 42m. on the morning of the 13th inst. The declination and horizontal force curves suffered a simultaneous rise, while the vertical component decreased. The most important phase of the perturbation occurred between 11 p.m. and 2 a.m.; and about 5 p.m. of the 14th the elements had returned to their normal value. The disturbance in declination amounted to 1° 25', and the horizontal and vertical components varied respectively more

than  $\frac{1}{10}$  and  $\frac{1}{20}$  of their normal value.—Observations of atmospheric electricity, made by means of a captive balloon, by M. E. Semmla.—On the determination of the state of dissolved salts from a study of contraction, by M. Georges Charpy.—On some properties of bismuthic acid, by M. G. André.—On a carbide of barium, by M. Maquenne. (See Notes.)—Transformation of aromatic amines into chlorinated hydrocarbons, by MM. Prud'homme and C. Rabaut.—On the principles which accompany chlorophyll in leaves, by M. A. Etard.—Improvement of the culture of industrial and fodder potatoes in France results of the season 1891, by M. Aimé Girard.—Contributions to the study of unplastered wines, by M. H. Quantin.—On the assimilation of carbohydrates, by M. Hanriot.—On the presence of numerous diatoms in the Cretaceous of the Paris basin, by M. Cayeux.—On the existence of zeolites in the calcareous Jurassic rocks of Arriage, and on the dissemination of these minerals in the Pyrenées, by M. A. Lacroix.

## AMSTERDAM.

**Royal Academy of Sciences, January 30.**—Prof. van de Sande Bakhuysen in the chair.—Prof. Pechelharig spoke of the composition of the fibrin ferment. When oxalated blood-plasma is diluted with water and treated with acetic acid till moderate acid reaction, the precipitate consists chiefly of a substance which is soluble in alkali, in an excess of acid, and in neutral salt-solutions, and from which, by the action of pepsin-hydrochloric acid, is split off a nuclein—a substance that thus must be considered as a nucleo-albumin. This nucleo-albumin acquires, combined with lime, all the properties of fibrin ferment. It is very probable that this nucleo-albumin issues from the corpuscles of the blood.—Prof. Max Weber gave some results of his investigations of the fresh-water fauna of the islands of Sumatra, Java, Flores, Celebes, and Saleyer. Among the Crustacea, the Entomostraca are not essentially different from European forms. Isopods are only represented by marine species: *Ichthyoxenus*, *Tachaea*, *Rocinela*, and *Bopyridæ*. Amphipods are extremely rare, and only *Orchestia* was found. Nearly 70 species of Decapods were collected, out of which 33 are living also in brackish and sea water. It could be proved that immigration out of the sea into the rivers had taken place. An account was given of the life-history of *Ichthyoxenus Tellinghausii*.

## CONTENTS.

PAGE

The Science Museum and the Tate Gallery . . . . .	385
Chemical Technology. By W. A. T. . . . .	386
An Agricultural Text-book. By W. T. . . . .	388
Hydro-Idealism. By C. Li. M. . . . .	389
Physiology. By A. F. . . . .	390
<b>Our Book Shelf:</b> —	
Vasey: "Grasses of the South-West" . . . . .	390
Kennedy: "Sporting Sketches in South America" . . . . .	390
<b>Letters to the Editor:</b> —	
Cirques.—Prof. T. G. Bonney, F.R.S. . . . .	391
Bedford College and the Gresham University.—Dr. W. J. Russell, F.R.S., and Lucy J. Russell . . . . .	391
The Implications of Science.—Edward T. Dixon . . . . .	391
The Value of Useless Studies.—Prof. Geo. Fras. Fitzgerald, F.R.S. . . . .	392
The Nickel Heat Engine.—W. B. Croft . . . . .	392
The University of London. By W. T. Thiselton-Dyer, C.M.G., F.R.S. . . . .	392
A Preliminary Statement of an Investigation of the Dates of some of the Greek Temples as derived from their Orientation. By F. C. Penrose . . . . .	395
Volcanic Action in the British Isles . . . . .	398
The Centenary of Murchison . . . . .	398
H. W. Bates, the Naturalist of the Amazons. By A. R. W. . . . .	398
Thomas Archer Hirst . . . . .	399
Dr. Thomas Sterry Hunt. By W. Topley, F.R.S. . . . .	400
<b>Notes</b> . . . . .	401
<b>Our Astronomical Column:</b> —	
The Solar Disturbance of 1891, June 17 . . . . .	404
Photography of Solar Prominences . . . . .	404
On the Variation of Latitude . . . . .	404
Non-Euclidian Geometry. By Prof. H. Poincaré; Translated by W. J. L. . . . .	404
<b>Societies and Academies</b> . . . . .	407

THURSDAY, MARCH 3, 1892.

## DEEP-SEA DEPOSITS.

*Report on the Scientific Results of the Voyage of H.M.S. "Challenger" during the Years 1873-76, under the command of Captain George S. Nares, R.N., F.R.S., and the late Captain Frank Tourle Thomson, R.N. Prepared under the Superintendence of the late Sir C. Wyville Thomson, F.R.S., and now of John Murray, LL.D., Ph.D., &c., one of the Naturalists of the Expedition. Report on Deep-Sea Deposits, based on the Specimens collected during the Voyage.* By John Murray, LL.D., Ph.D., and the Rev. A. F. Renard, LL.D., Ph.D., Professor of Geology and Mineralogy in the University of Ghent. Pp. xxix. and 496; with 43 Charts, 22 Diagrams, and 29 Lithographic Plates. (London: Published by Order of Her Majesty's Government, 1891.)

GEOLOGISTS have had to wait long for this very important work, but now that it lies before them, we believe that the general verdict will be that it was worth while to wait even sixteen years for a monograph so excellent in design and so complete in execution. It must not be forgotten, too, that much of the information contained in this volume has been already given to the scientific world—first in Mr. Murray's Preliminary Report on the subject, published in the Proceedings of the Royal Society; and secondly in a series of papers written by him in conjunction with Prof. Renard, and published in the Proceedings of the Royal Society of Edinburgh.

It is a most fortunate circumstance that the naturalist on board the *Challenger*, who had charge of the collection, examination, and preservation of the samples of the deposits collected by the sounding-apparatus and the dredge, as well as of those obtained by means of the tow-nets and tangles, has been able during the long period that has elapsed since the return of the vessel to England, to devote his attention to their careful study and description. In the work of dealing with this vast mass of materials, as the preface informs us, Mr. Murray has had the co-operation of Mr. Frederick Pearcey, who accompanied the Expedition, and was afterwards assistant in the *Challenger* Office, and also of Mr. James Chumley. Especially fortunate has been the circumstance that Sir Wyville Thomson and Mr. Murray were, in 1878, able to secure the aid of the eminent Belgian petrographer, Prof. Renard, who is so great a master of those microscopic methods of research which have played no unimportant part in the development of geological science during recent years. In the exact determination of the minute fragments of minerals which occur in these deposits, Prof. Renard's knowledge of the optical and chemical methods of microscopic research has proved of especial value; and the assurance that, during several months in the years 1881 and 1882, the Belgian petrographer was able to devote himself to the work of investigating these deposits will invest the mineralogical determinations with an authority which they could not otherwise possess.

The introduction to the work consists of an excellent summary of the references contained in various authors,

beginning with Herodotus, Plato, and Skylax, to the supposed nature of the sea-bottom. The sagacious remarks on the subject by the Italian naturalists, who were the real founders of the science of geology in the fifteenth century, receive appreciative notice; and the earliest attempts to deal with the deposits of the deep seas, especially those of Soldani, Ehrenberg, Sir Joseph Hooker, Edward Forbes, and Prof. J. W. Bailey, have full recognition. The important memoir of Prof. W. C. Williamson on the mud of the Levant is noticed; but the authors seem to be scarcely aware how many of the later discoveries in this branch of science were foreshadowed in the remarkable monograph of the Manchester Professor. A general account of the results obtained by the chief expeditions fitted out for the study of the deep ocean and its deposits—expeditions which preceded and followed that of the *Challenger*—leads up to a division of marine deposits into "Terrigenous" and "Pelagic," a classification which, if not too rigidly applied, appears to be serviceable and even necessary.

The first chapter is devoted to the various methods of obtaining, examining, and describing deep-sea deposits, and here the general arrangements made on board the *Challenger*, which are familiar to most readers from the description given by Sir Wyville Thomson in his "Voyage of the *Challenger*," and the narrative volumes of the Report, receive very full and exhaustive treatment. The precise account of the apparatus, illustrated as it is by numerous woodcuts, cannot fail to be of great value to those engaged in fitting out similar expeditions. The study of the methods employed in the sifting, fractional decantation, and chemical examination of the several deposits is essential to the proper understanding of the results detailed in succeeding chapters of the work. The methods of analysis employed by Prof. Brazier at Aberdeen, and by MM. Renard, Sipöcz, Hornung, and Klement, in the laboratory of Prof. Ludwig, of Vienna, and in M. Renard's laboratory at Brussels, are given in full detail, and will prove of great service when the results described in the present volume come to be compared with those of future investigators.

The second chapter consists of a series of synoptical tables, occupying 114 pages, in which the nature and composition of every deep-sea deposit collected during the voyage of the *Challenger* is described. In each case the number of the station, the date, the latitude and longitude, the depth in fathoms, the temperature at the surface and the bottom are given; and these particulars are followed by (1) a general description of the material brought up; (2) the percentage of calcium carbonate; (3) a list of the chief Foraminifera present; (4) an enumeration of the other calcareous organisms; (5) the percentage of insoluble residue; (6) a list of the siliceous organisms; (7) of the minerals; (8) a description of the fine washings; the last column being devoted to additional observations. These synoptical tables are followed by a discussion of the variation of the deposits with change of conditions along the different lines of soundings and dredgings. This general summary of the results, which occupies 36 pages of the work, constitutes an admirable *résumé* of the information contained in the tables.

Chapter iii. is devoted to the description of recent

marine formations and the different types of deep-sea deposits: their composition, geographical and bathymetrical distribution. All marine deposits which are not "Littoral," or formed between high- and low-water marks, or "Shallow-water," a term which the authors limit to the interval between low-water mark and a depth of 100 fathoms, are classified in this work as deep-sea deposits. They include Coral Mud, Volcanic Mud, Green Mud, Red Mud, and Blue Mud (which are classed as Terrigenous Deposits, formed in deep and shallow water close to land-masses), and the Pteropod ooze, Globigerina ooze, Diatom ooze, Radiolarian ooze, and Red Clay (which are grouped as Pelagic Deposits, formed in deep water removed from land). In the case of each of these deposits the proportions and characters of the organic and inorganic materials are given, and the results of a large number of chemical analyses, some of which are now published for the first time, are discussed. Perhaps one of the most interesting of the many valuable discussions contained in this chapter is that which deals with the proportions of the ocean-floor covered by different kinds of deposits. A map (Chart I.) is devoted to an attempt to illustrate the nature of the ocean-floor over the whole of the globe, and we cannot resist the temptation of quoting the general estimate to which the authors have been led by their laborious and patient researches. These results are based not only on the collections made during the *Challenger* Expedition, but on many obtained before and since, which have all passed through the hands of the authors; they include the materials brought up in no less than 1600 soundings from the Atlantic, 300 from the Indian Ocean, and 400 from the Pacific, all from depths exceeding 1000 fathoms. It is evident, therefore, that the map and estimates, though admittedly only approximate, are based on a mass of data such as has never been brought together before.

The total area of the surface of the globe is estimated at 196,940,700 square miles, of which dry land occupies about 53,681,400 square miles, and the waters of the ocean 143,259,300 square miles. The approximate extent of the areas of the sea-floor occupied by each type of marine deposits is given as follows:—

	Mean depth in fathoms.	Area in square miles.
"Littoral Deposits"	—	62,500
Shallow Water Deposits	—	10,000,000
TERRIGENOUS DEPOSITS.	Coral Mud ... ..	740 ... .. 2,556,800
	Coral Sand ... ..	176 ... ..
	Volcanic Mud ... ..	1033 ... .. 600,000
	Volcanic Sand ... ..	243 ... ..
	Green Mud ... ..	513 ... .. 850,000
	Green Sand ... ..	449 ... ..
	Red Mud ... ..	623 ... .. 100,000
Blue Mud ... ..	1411 ... .. 14,500,000	
PELAGIC DEPOSITS.	Pteropod ooze ... ..	1044 ... .. 400,000
	Globigerina ooze ... ..	1996 ... .. 49,520,000
	Diatom ooze ... ..	1477 ... .. 10,880,000
	Radiolarian ooze ... ..	2894 ... .. 2,290,000
	Red Clay ... ..	2730 ... .. 51,500,000

Some of the most striking results, which make themselves apparent from a study of this estimate and the accompanying chart, are the very wide distribution of the Foraminifer ooze and the red clay in the Atlantic and Pacific respectively; and the remarkable manner in which the deposits of vegetable origin replace those

composed of the remains of animals on the bottom of the Antarctic Ocean.

Chapter iv., dealing with the materials of organic origin, is, we are informed in the preface, entirely from the pen of Mr. Murray. The Reports of the late Mr. H. B. Brady, of Prof. Haeckel, and of Count Castracane, on the Foraminifera, the Radiolarians, and the Diatomaceæ brought home by the *Challenger* Expedition, have already supplied naturalists with the means of drawing many important deductions; but Mr. Murray still finds much to say on the subject, which is not only new, but of very great interest. In the couple of pages devoted to the description of those curious and abundant organisms the Coccospheres and Rhabdospheres, which Mr. Murray here refers without doubt to the Calcareous Algae, we could have wished that he had been able to announce that he had succeeded in inducing some competent botanist to undertake the study of the material brought home. One of the most important discussions in this chapter is that on the disappearance of calcic carbonate in the deeper deposits. The estimate made by Mr. Murray of the mean percentage of calcic carbonate in the different deposits, as the result of a large number of chemical analyses, is as follows:—

	Percentage of CaCO <sub>3</sub> .
Coral Mud and Sand ... ..	86.41
Pteropod ooze ... ..	79.26
Globigerina ooze ... ..	64.53
Diatom ooze ... ..	22.96
Blue Mud and other Terrigenous } deposits ... ..	19.20
Red Clay ... ..	6.70
Radiolarian ooze ... ..	4.01

The facts cited by Mr. Murray, on the authority of Mr. John Rathay (p. 282), on the ease with which the remains of the Diatomaceæ are dissolved, are of especial importance to the geologist who is called upon to explain the origin of the silica now forming nodules and bands in beds of limestone, and which he is tempted to refer entirely to the larger organisms like Siliceous Sponges, because remains of these are sometimes preserved. All the observations made in the existing deep seas, however, point to the conclusion that the minute Diatoms and Radiolarians play a much more important part in separating the soluble silica from sea-water than do the Siliceous Sponges.

Chapter v., dealing with the mineral substances found in deep-sea deposits, is full of interest. The mineral particles which are obviously derived from the solid crust of the globe are first dealt with, and in the account of the pumice, the basic volcanic glass, and the palagonite of the deep-sea deposits, Prof. Renard exhibits alike his wide mineralogical knowledge and his skill in dealing with microscopical and often obscure materials. The coloured lithographic plates illustrating this part of the work, which have been drawn by Prof. Renard, and engraved in Vienna, are of wonderful beauty and fidelity. A list of mineral particles detected in deep-sea deposits is given, and includes all, or nearly all, the common rock-forming minerals; but it is admitted that, with respect to the very minute particles in the finest washings, a considerable margin of doubt must always exist regarding their identification. We could wish that it were possible, in the space at our command, to give a summary of the

facts leading to the conclusion that materials of extra-terrestrial origin play a not unimportant part in the accumulations which are taking place on the deepest ocean-floors. We can only call attention, however, to the clear descriptions and admirable plates which illustrate this part of the subject. The exquisite drawings of magnetic spherules and of chondre upon Plate xxiii., enable the reader to judge of the real nature of the evidence relied upon, and an examination of these figures cannot but remove any lingering doubt, as to the true nature of these materials, from the minds of all those who are familiar with the minute structure of meteorites.

The last chapter of the work deals with the chemical products which are formed *in situ* upon the floor of the ocean, and here, perhaps, the interest of the work for the geologist culminates. We can only refer to the numerous and interesting problems connected with the origin of the red clay, the mode of formation of the glauconite-casts, the source of the materials and the chemical processes involved in the formation of the phillipsite and other zeolites, the manganese-nodules, and the phosphatic and other concretions. The 76 pages of text, and the admirable drawings which illustrate this part of the subject, will excite the interest of all students of the subject. They enable the reader to form a clear idea of the forms and structure of the remarkable manganese nodules, and of the ear-bones, teeth, and other objects which, in a more or less phosphatized condition, are strewn over the deepest part of the ocean-floors. In an appendix is given a report on the analysis of the manganese-nodules by Dr. John Gibson, especial attention being directed to the detection of the rarer elements by spectroscopic and other methods. While traces of barium, strontium, lithium, molybdenum, zinc, titanium, vanadium, and thallium were found, cæsium, rubidium, and the metals of the cerium and yttrium groups were sought for in vain. The quantitative analyses, as shown by the tabular statements, would appear to have been executed with every modern refinement, and were carried out, by Prof. Crum Brown's permission, in the Chemical Laboratory of the University of Edinburgh. Another appendix contains an account of the analyses which have been made of the different varieties of deep-sea deposits.

In conclusion, we may point out that the work is worthy of praise, not only for what it includes, but for what it omits. The time has not yet arrived for a full discussion of the geological bearings of many of the new and interesting facts brought to light by the *Challenger* Expedition. Theoretical discussions are, therefore, wisely kept, in the monograph before us, within very narrow bounds. It is evident that much of the work was written before the publication by Messrs. Jukes-Browne and Harrison of their interesting memoirs on the geology of Barbadoes, and before the discovery of the Radiolarian-chert of Ayrshire and other districts. These discoveries, it is true, are mentioned in footnotes, but have evidently had but little influence in moulding the views of the authors. Few geologists will be prepared to accept the views of Mr. Murray, when he endorses the conclusion of M. Cayeux that the white chalk should be classed as a terrigenous deposit. But on this and other points the views of the authors are stated with a commendable absence of dogmatism, and a manifest desire to lay before readers of

the work all the facts bearing upon the questions at issue, even when they are manifestly hostile to the conclusions adopted.

We cannot bring this notice to an end without congratulating the editor of the *Challenger* Reports on the nearly approaching close of his heavy labours. Only by a worker gifted with unrivalled powers of organization, as well as with indomitable energy, could such a task have been brought to a successful termination. The mass of materials was so vast and multifarious, the interests involved in their distribution so wide and often conflicting, while personal considerations could not always be kept from exercising a disturbing influence, that it is less surprising that criticism should sometimes have been provoked, than that results so substantial, and, on the whole, satisfactory, should in the end have been attained.

The present Report forms the last of the series of splendid monographs in which the results of this famous Expedition—one which will be recorded in the history of Science as perhaps the grandest concession to her claims made up to the present time by the British or any other Government—are fully recorded and discussed. The final volume of the *Challenger* Reports, which, it is stated, will probably be published in the course of the present year, will contain lists of the organisms collected at every observing station, with other details, in the nature of a summary of results.

JOHN W. JUDD.

#### PARASITIC FUNGI AND MOULDS.

*British Fungi: Phycomycetes and Ustilagineæ.* By G. Masee. (London: Reeve and Co., 1891.)

IT is a somewhat remarkable fact that no one has hitherto written a book on the British *Phycomycetes*, the common white moulds so often found growing on decaying substances or in water, or as parasites of a most destructive kind in various valuable plants; and the opportunity thus afforded to the writer of the present volume was a good one, of which, it is but fair to say, he has taken considerable advantage. The *Ustilagineæ* of this country had already been treated by Mr. Plowright, but there are sufficient differences between the works of the two authors to make Mr. Masee's book none the less noteworthy on that account.

When we consider the great variety of "white moulds," such as *Mucor*, that infest all kinds of rotting fruits and other vegetable debris, of parasites such as the *Phytophthora* of the potato disease, and the *Peronospora* which destroy onions, vines, and other valuable vegetable produce, to say nothing of the *Saprolegnia* of the salmon disease, the *Pythium* which decimates seedlings of all kinds, and the *Empusa* which kills our house-flies in autumn, and glues their dead bodies to the window-panes—when we regard these and a host of other extraordinary and important *Phycomycetous* Fungi, it seems more and more surprising that no one has compiled an intelligible account of these things in this country; yet so it is, and the author of this little book of a couple of hundred of pages of carefully, and, on the whole, pleasantly-written matter, ought certainly to deserve the thanks of botanical readers for undertaking the difficult task, and discharging it as well as he has done.

In reviewing the work there are two parts to be noticed, and two points of view from which to criticize them: the first fifty pages or so are concerned with a general popular account of the morphology of Fungi in the wider sense, while the remainder is devoted to the setting forth of the British genera and species (so far as they have been worked up) of the two groups specially dealt with.

The general account must strike a careful reader as not only exhibiting a good deal of knowledge on the part of a writer who is wishful to put it at the disposal of all who care for it, and in a pleasant style; but also as showing what enormous advances have been made in the popular exposition of these matters within the last few years. When we look back to the systematic books on Fungi of ten to fifteen years ago, they appear hopelessly dry and uninteresting; whereas here we have a compact, neat little volume, with a store of interesting information thrown in as an introduction to the more serious detailed work which follows.

We do not mean to say that this part of the book is without mistakes or slips, either of fact (*e.g.* the statement on p. 49 regarding mutualism between Fungi and Phanerogams) or judgment (*e.g.* the reference to "phanerogamic Fungi" on p. 11). Moreover, there are evidences of careless proof-reading, as at the foot of pp. 41 and 42. But it is far more easy to pick small holes in a book like this than to do proper justice to what is good and useful in it; and we prefer to dwell on the more important positive points, than to emphasize the fewer and more trivial drawbacks.

The more purely systematic part of the work shows evidence of careful and conscientious industry, suggesting constant reference on the part of the author to typespecimens and authorities. Of course, it is not so interesting to the general reader, but the diagnoses are so clear, and so simply written, that we think any amateur ought to be able to follow them with the object in hand; as for professional mycologists, they will probably wonder that it could all be put so plainly—at the same time, they will suspect something is wrong with the German reference on p. 162, and will probably remark on the chapter on "Fossil Fungi." They may also inquire why *Ustilagineæ* are taken with *Phycomycetes*. The author answers this question on p. 160: he follows Brefeld in regarding *Protomyces* as linking the two groups. The somewhat antiquated method of obtaining sections, on p. 62, had better have been omitted.

The most interesting points to the systematists will be Mr. Masee's almost consistent alterations of Plowright's authorities for the species of the *Ustilagineæ*, and his addition of one or two new ones—*e.g.* *Ustilago salveii* (p. 177), *Doassansia comari* (p. 198), and *Protomyces purpureo-tingens* (p. 164); they will also notice the fusion of some species kept apart by Plowright—*e.g.* on pp. 178 and 186—and the separation of the two species of *Tuber-*cinia**, on pp. 203 and 204.

We note, also, that Masee has altered the name of Trail's *Entyloma matricariae* to *E. Trailii*, possibly on good grounds; but we think it a mistake to use such specific names, here and elsewhere, seeing how much Fungi are in need of useful distinctive appellations.

The figures on the six plates are fairly well drawn and selected, and the references to them are useful and

to the point. We have not tested the indices in detail, but they are very well planned, and appear to be accurate.

On the whole, and without being blind to its faults, we think this little book should be welcomed as a useful manual on the subject, and should certainly be in the hands of students of botany who wish to know something of British mycology.

#### OUR BOOK SHELF.

*A Treatise on the Geometry of the Circle, and some Extensions to Conic Sections by the Method of Reciprocation.* With numerous Examples. By W. J. McClelland, M.A. (London: Macmillan, 1891.)

THIS is a full book, written on the lines which previous works by Irish mathematicians have made familiar to us. The author acknowledges his indebtedness to the writings of Mulcahy, Salmon, and Townsend. He has also freely consulted the similar works by Cremona and Catalan, and in his treatment of the recent geometry has in many cases gone to the fountain-head in the memoirs of Brocard, Neuberg, and Tarry. Though in parts proceeding on parallel lines with Casey's "Sequel," there is a good deal of other matter not to be found in that work. The writer's object is to give a concise statement of those propositions which he considers to be of fundamental importance, and to supply numerous illustrative examples. Many of the exercises are worked out in an elegant manner, and to the major part of the others useful hints are given. Chapter i. is introductory; chapter ii., in four sections, is devoted to "Maximum and Minimum"; chapter iii., also in four sections, rapidly touches upon "Recent Geometry"; chapter iv. discusses the general theory of the mean centre of a system of points; and chapter v. treats of collinear points and concurrent lines.

Chapters vi., vii., and viii. are concerned with inverse points with respect to a circle, poles and polars (with respect to a circle), and coaxial circles. In these chapters will be found ample food for the student. Chapter ix. gives an account of the theory of similar figures, and here we specially notice the sketch of Neuberg's and Tarry's researches on three similar figures. Circles of similitude and of antisimilitude form the subject of chapter x. Here some interesting problems are solved. Inversion (chapter xi.), general theory of anharmonic section (chapter xii.), involution (chapter xiii.), and double points (chapter xiv.) close what must unhesitatingly be called a varied and ample menu. The work, being confessedly to a great extent elementary, of course brings before the reader much that is old; there is, however, novelty in the treatment and also in the matter. There is one feature we have omitted to mention, to which Mr. McClelland draws attention, and that is the application of reciprocation to many of the best known theorems by means of which the corresponding properties of the conic are ascertained. To go through all the examples would occupy more time than we can spare, but we have dipped into all parts and brought up good results. In the text we have noted one slip: p. 60, l. 12 up should be  $\pi - B$ . No doubt we have omitted to mark other errata. The figures, which are white lines on a black block, carry our thoughts back to old Cambridge days, when we turned over the pages of our Miller's "Hydrostatics." The geometer will find much to interest him in Mr. McClelland's work.

*Kalm's Account of his Visit to England on his Way to America in 1748.* Translated by Joseph Lucas. (London: Macmillan and Co., 1892.)

KALM was a well-known Swedish botanist and economist of the eighteenth century. In 1747 he became Professor of Economy at Åbo, and in the same year the Swedish

Government and Academy of Sciences commissioned him to go to America, the object being that he should describe the natural productions of that part of the world, and introduce into Sweden any useful North American plants which might be expected to thrive in Northern Europe. Kalm reached England in February 1748, and remained there until August, when he started for America. On his way back, in 1751, he visited this country again, staying about a month. An account of a portion of his travels he afterwards published in three volumes. The part relating to America was translated into English in the eighteenth century by J. Reinhold Forster, but the author's account of England appears now in English for the first time. The work is full of interest, and was well worth translating. Kalm first records his impressions of London and suburbs, and then takes us successively to Woodford, Little Gaddesden, and Gravesend, each of which is made a centre for a number of observations, chiefly in connection with agriculture. To students of the history of agricultural methods the work will be invaluable; but it will also give pleasure to readers with a less serious purpose, for it contains suggestive references to many aspects of English life, and the author always writes accurately and with good taste. The translator has accomplished his task with great spirit and intelligence.

LETTERS TO THE EDITOR.

[The Editor does not hold himself responsible for opinions expressed by his correspondents. Neither can he undertake to return, or to correspond with the writers of, rejected manuscripts intended for this or any other part of NATURE. No notice is taken of anonymous communications.]

The University of London.

It is always a pleasure to read Mr. Thiselton-Dyer's expressions of opinion on University organization. I have before now joined my word to his in condemnation of Sir George Young's proposed "Albert" or "Gresham" Charter. Nevertheless, I must beg you to grant me space to point out some inaccuracies in Mr. Dyer's letter in your columns of February 25 (p. 392), the purpose of which seems to be to give reason for distrusting, or, at any rate, treating with little confidence, University organizations on the German or professorial model.

Mr. Dyer rightly enough appeals to his own early experience as a teacher and student. It is therefore fair to point out that this experience does not include a German University, and that the conception of it sketched by him, and of a professor's relations to his pupils therein, is entirely erroneous. Mr. Dyer cannot free his mind of the University of London tradition. He regards the German as well as all Universities as organizations for bringing candidates up to a certain pitch of examination-room performance. This is not what a German University attempts. The measure of its success is not what Mr. Dyer would suggest, but is found in the contributions to science, the new knowledge created by the professor and his students, and in the spread of a love for producing such new knowledge. Mr. Dyer attributes to Lord Sherbrooke a strange saying—namely, that professors who examine their own students are comparable to "tradesmen who sample their own goods." I can hardly credit that Lord Sherbrooke ever said anything so unmeaning. We have all heard the professor-examiner compared to "a merchant who brands his own herrings"—but this "sampling of his own goods" is a new charge.

Lastly, I must point out that Mr. Dyer, by inadvertence, attributes to me a statement, or rather assent to a statement, before the Royal Commission on the proposed new University for London, which had exactly the opposite significance to that which he gives to it. Mr. Dyer says that I admitted to Sir William Thomson that "a teacher may, with judiciousness of course, and with common-sense in his teaching, teach the best that he knows" under the present University of London system. I am glad to note that Mr. Dyer has looked at the Blue-book. But if he had read more carefully he would have seen that Question 662, by Sir William Thomson, was, "Can an examiner under the London system ask the best that he

knows?" and that my answer was, "Probably not." Then Sir William continued (Question 663): "But, on the other hand, a teacher may, with judiciousness, &c., teach the best that he knows?" to which I answered, "Yes." Then said Sir William (Question 664), "If he is examining his own pupils he may bring into the examination something of the best and the newest?" to which I replied, "Certainly."

It is clear enough that Sir William Thomson's proposition, to which I assented, was that, under the London system of external examiners, an examiner cannot put questions involving the best and newest; yet a teacher may and should teach the best and newest; and if, contrary to the principle of the London system, the examiner is the teacher, he can introduce with judgment into the examination this element of the best and newest.

Mr. Dyer has not, it seems to me, yet mastered the distinctive features of the German or professorial University system, and is, therefore, not a trustworthy guide as to its advantages and disadvantages. E. RAY LANKESTER.

Superheated Steam.

A COMMUNICATION from Lord Rayleigh, under the above heading, in NATURE of February 18 (p. 375), draws attention to a misunderstanding which has been pointed out by me on every occasion in the last twelve years when I have been explaining the thetaphi diagram in public, saying that "only the heat which superheated had its efficiency increased, according to the temperatures at which its respective portions were imparted to the working substance." Mr. Willans has also been disseminating correct views regarding this point amongst those who visit his engine-testing laboratory. The diagram given by me in my paper on thetaphi, in 1880, makes this very plain.

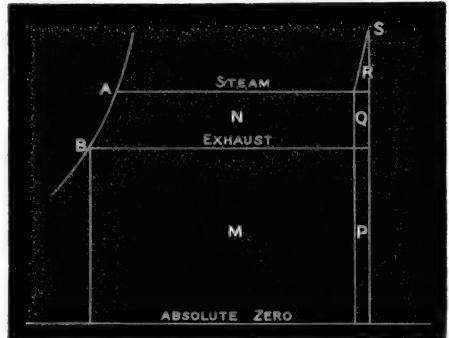

The vertical ordinates here are absolute temperatures, and the area is heat or energy. Without superheating, Carnot's law gives, between temperatures A and B—

$$E = \frac{W}{H} = \frac{\text{Work}}{\text{Heat}} = \frac{N}{M + N}$$

Superheating to temperature S, the same law gives—

$$E_s = \frac{W_s}{H_s} = \frac{\text{Work}}{\text{Heat}} = \frac{N + Q + R}{M + N + P + Q + R}$$

An arithmetical expression for these quantities, practically accurate, is obtained by extending the formula given in Mr. Willans's paper on engine trials, at the Institution of Civil Engineers—

- A = steam temperature, not superheated.
- B = temperature of exhaust.
- S = superheated temperature.

The temperatures are all absolute, and, to suit engineers, in Fahrenheit measure, and the steam data of Regnault are adopted. The mean specific heat for the range of superheating is taken = 0.5. This will be nearly correct at high temperatures, and this is strictly in accordance with my statement that the specific heat of steam at low temperatures is 0.39 at constant pressure. The above expressions become, without superheating,

$$E = \frac{W}{H} = \frac{\left(\frac{A - B}{A + B} + \frac{1437}{A} - .7\right)(A - B)}{1437 + .3A - B}$$

and with superheating,

$$E_s = \frac{W_s}{H_s} = \frac{(A-B) + \frac{1437}{A} - 7 + \frac{S-A}{S+A}}{\frac{1437 + \frac{S-A}{2} - \frac{A}{5} - B}{S+A}}$$

Numerical example. Say that  $A = 800^\circ$ ,  $B = 600^\circ$ ,  $S = 1000^\circ$ . Substituting these values, we get—

$$E_s = \cdot 2301 \text{ without superheating,}$$

$$E_s = \cdot 2389 \text{ with superheating.}$$

That is, less than 4 per cent. is gained by superheating  $200^\circ$ .

So far, I support Lord Rayleigh's view, or, rather, he says what I have been impressing upon engineers for the last twenty years. If this had been all I had to say, I would not have written now; but Lord Rayleigh adds to his statement what is to me an astounding announcement, that, "by the addition of saline matters, such as chloride of calcium or acetate of soda, . . . the possible efficiency, according to Carnot, may be increased." I hasten to call this assertion into question, because there are so many people ready to bring engines on new principles into the field of joint-stock bubbles; and I am afraid we may be having, quite apart from Lord Rayleigh, a new field engine syndicate and floated on the strength of this communication and the signature thereto, before its meaning is understood.

As I understand thermodynamics there would be no gain from superheating by a saline solution, over the usual method of superheating steam raised from pure water. The saline mixture is not the working substance. Carnot's law refers to the working substance only, and not to anything left in the boiler. The first step in evaporation from the saline mixture is to separate a particle of water from the salt. In the act of separation, the temperature of the water particle falls to the temperature due to the pressure, and at that temperature it is evaporated into steam particles, which immediately become of the same temperature as the saline mixture. These steps are followed by every particle of water, each independently of every other particle. Of course, we cannot practically test those temperatures, as the complete series is run through for each particle in a fraction of the twinkling of an eye, and immersed in a liquid of greatly higher temperature. A tethphi diagram for this would give, at B, A, and extending upwards to temperature S, a very narrow figure 8, whose loops are equal, and drawn, as in a figure 8, one right-hand and the other left-hand. The line for the reception of latent heat would be identically the same line, the horizontal through A, as when the evaporation was from pure water. It is evident, therefore, that, according to my lights, the efficiency will be precisely the same as without the salt in solution.

Some ten years ago this plan was submitted to me for my opinion by an eminent mechanical engineer, Mr. S. Geoghegan, who, I understood, had then patented it. The above is the substance of the opinion I then expressed, and nothing I have learned since induces me to change my view of it now.

The "complete elaboration of this method," hinted at in the last paragraph of Lord Rayleigh's communication, is not clear to my mind; and it is just possible that a few sentences of explanation would show me that I have been hitting away at something that was not intended by the writer. If so, my excuse must be that I have read the statement, as every practical engineer would, to mean that the latent heat is imparted along the isothermal of the superheat. When I get to understand the first sentence of the last paragraph of the communication, I may be able to confirm the anticipation of higher economy.

J. MACFARLANE GRAY.

THE passage quoted by Lord Rayleigh from my book on the steam-engine, in some remarks on this subject in your number of the 18th inst. (p. 375), is taken from one of the earlier chapters, which is devoted to engines which receive and reject heat at constant temperature. When such an engine is used as a standard of perfection, by comparison with which some other engine is tried, it appears to me that the maximum and minimum temperatures of the working fluid must in the first instance be adopted as the temperatures of reception and rejection of heat; and in fact, without entering on questions reserved for discussion in a later chapter, no lower value than the maximum could well have been adopted. There is no doubt that the practice of com-

paring together engines with different cycles has been a source of considerable misapprehension, and very probably the language used in the passage in question may be insufficiently guarded. The use of superheated steam on this method of comparison is not a gain, but a considerable loss, for the heat might ideally all have been used at the maximum temperature, and is so used in the standard of comparison.

The practical case in which the boiler pressure is given is, of course, quite different. There is a gain by superheating, but, putting aside cylinder condensation, the gain is small, because such a small percentage of the heat is employed at temperatures above that of the boiler.

The process was originally introduced with the object of drying the steam and diminishing cylinder condensation; and now that the practical difficulties attending its use have been in great measure removed (as I am informed), by the employment of mineral oil for lubricating purposes, it may be hoped that it may be revived, and be the means of a considerable economy.

The action of superheated steam in a cylinder was explained and its economy experimentally demonstrated by Hirn some fifteen or twenty years ago. I have given the explanation briefly on p. 352 of my book, but I purposely avoided discussing questions relating to it, being of opinion that, in the present state of our knowledge, theoretical investigations are of doubtful value. I am certainly, however, under the impression that the true nature of the economy obtained by its use has for a long period been very generally recognized, though some writers in dealing with the theory of heat engines may have expressed themselves incautiously. It would, I think, be very desirable, in teaching the subject, to introduce as early as possible the idea of a mean temperature of supply. I have dwelt on the importance of this conception in the latter part of my book, and I am sure its introduction would remove many difficulties.

Greenwich, February 24.

JAMES H. COTTERILL.

LORD RAYLEIGH'S interesting communication on superheated steam in your last issue (p. 375) leads me to ask whether it is generally known that solutions can be heated up to temperatures higher than  $100^\circ$  by passing into them steam at  $100^\circ$ . The late Peter Spence at the Exeter meeting of the British Association in 1869 called attention to the fact that by simply passing steam at  $100^\circ$  directly into a strong solution of nitrate of soda (other salts will of course answer) it was possible to raise the liquor to its boiling-point, about  $121^\circ$ .

Superheated steam is frequently used for heating up liquors in chemical processes on the large scale, but where a slight dilution is no disadvantage, the simpler operation of heating with ordinary low pressure steam might be adopted more generally than it is. Spence used steam in this way for the purpose of extracting sulphate of alumina from alum shales.

G. H. BAILEY.

The Owens College, Manchester, February 22.

#### Poincaré's "Thermodynamics."

PERMETTEZ-MOI de répondre en quelques mots à l'article que M. Tait a consacré à ma thermodynamique, non que je veuille prendre la défense de mon imprimeur, ou réfuter des reproches généraux, contre lesquels ma préface proteste suffisamment.

J'abuserais ainsi de votre hospitalité et de la patience de vos lecteurs; je me bornerai donc à discuter une seule des critiques de M. Tait, et je choisirai celle que ce savant paraît regarder comme la plus importante et qu'il a formulée avec le plus de précision. Je commence par en reproduire le texte:—

"Even the elaborate thermo-electric experiments of Sir W. Thomson, Magnus, &c., are altogether ignored. What else we get gather from passages like the following?—

" . . . Si l'effet Thomson a pu être mis en évidence par l'expérience, on n'a pu jusqu'ici constater l'existence des forces électromotrices qui lui donnent naissance. . . ."

Rappelons d'abord que, dans l'étude des phénomènes électrothermiques et thermiques qui se produisent au contact de deux métaux, il faut soigneusement distinguer trois choses:—

(1) Le phénomène calorifique connu sous le nom d'effet Peltier. Dans le cas d'un métal unique mais inégalement chauffé, le phénomène correspondant s'appelle *effet Thomson* et se manifeste par un transport de chaleur.

(2) La différence de potentiel vraie ou force électromotrice de contact.

(3) La force électromotrice apparente ou différence de potentiel entre les couches d'air voisines de la surface de deux métaux.



L'effet Thomson a été mis en évidence par l'expérience. M. Tait croit qu'il en est de même de la différence de potentiel vraie.

Où la phrase que j'ai citée plus haut n'a aucun sens, ou elle signifie qu'il me blâme d'avoir dit le contraire.

Or cette manière de voir ne soutient pas un instant d'examen. Nous n'avons aucun moyen de mesurer la différence de potentiel vraie.

Les méthodes électrostatiques ne nous font connaître que la différence de potentiel apparente; les méthodes électrodynamiques ne nous font connaître que la somme des forces électromotrices vraies dans un circuit fermé.

Enfin les méthodes indirectes, fondées sur l'écoulement ou sur les phénomènes électrocapillaires, ne sont pas applicables dans le cas qui nous occupe.

H. POINCARÉ.

### The Theory of Solutions.

It seems that, unfortunately, the period of misconceptions, whose victim the theory of solutions is, has not yet ended. For, after an explanation from my side of the theory of solutions as I understand it, Mr. J. W. Rodger, my critic, asserts (NATURE, p. 342) that "it cannot be admitted that a number of exact relationships constitutes a theory." From his further remarks, it must be concluded that he designates by the name *theory* what I would name a *hypothesis*, and that, according to him, van 't Hoff's application of the "gaseous laws" to solutions involves the hypothesis that there exists no interaction between the solvent and the dissolved substance.

It was therefore in vain that I stated in my letter, in italics, that many properties of the solutions, according to the new theory, "can be treated entirely independently of the question of a possible interaction between the parts of the dissolved substance and the solvent"; it was in vain that I pointed out that all the laws concerning these properties are solely consequences of the one law relating to the volume energy to be gained by making up a solution. This law, whose expression is  $\rho v = RT$ , in its various applications to solidification, vaporization, osmosis, &c., of solutions, is the issue of a great many special laws, the whole of which I name the new *theory* of solutions. Such a complex of laws, grouped around and derived from a main law, is what I call a *theory*; and if the theory, as in the present case, is everywhere in accordance with experience, the main law is to be regarded as correct. There is nothing of hypothetical nature in this theory, for, if once the main law,  $\rho v = RT$ , is given (by osmotic experiments or otherwise), all the special laws are merely thermodynamical consequences of it. And, I repeat, the main law involves no hypothetical assumption upon the mutual rôle of solvent and dissolved substance, but is solely the condensed expression of a great number of experimental facts.

Mr. Rodger asks why I did not state clearly in my book that, in my opinion, interactions between solvent and dissolved substance were possible. I can only reply that on suitable occasions I have done so. Besides the sentences quoted by Mr. Rodger himself, I have devoted (pp. 251, 252) half a page to the evidence that considerable interactions take place in salt solutions on dilution. But as the existence of such interactions, as I have shown, is of no consequence in the statement of the general laws, I have treated them as secondary, however interesting they may be as experimental facts, and I am more than ever persuaded by this discussion that I was right in doing so. For I have not written my book for readers prepossessed by some non-existing chemical theory of solutions, but for such as wish plainly to learn what is known about solutions.

Similar remarks are to be made as to the definition of solutions as mixtures. Even in the case of interactions, if, e.g., hydrates are formed in a solution, the solution is finally a mixture of the hydrates and the remaining solvent. For the contrary assumption—that the whole of the solvent is combined with the dissolved substance, that, e.g., in a somewhat diluted solution of common salt, there exist compounds, as  $\text{NaCl} + 1000 \text{H}_2\text{O}$ —is in such a degree at variance with all known facts that I did not think it worth while to discuss such an idea.

Lastly, Mr. Rodger terms the application of the formula of van der Waals to solutions as in general "highly questionable" and as "meaningless," if it is admitted that "something of the nature of a chemical reaction" between solvent and dissolved substance may occur. Mr. Rodger may convince himself from my book that this application is limited to cases in which I do not suppose the occurrence of chemical reactions. The reasons

of his doubts as to the validity of this application I cannot remove, because he has not stated his reasons. But it may be permitted to me to feel some doubts as to the validity of his reasons. For no other than van der Waals himself has taken up this very question, and has discussed (of course much more fully than I was able to do) the application of his formula to solutions, including also the case of interactions between the substances. His papers on this subject are inserted in the *Zeitschrift für physikalische Chemie*, v. p. 133, and viii. p. 188; and also in the *Archives Néerlandaises* of 1889 and 1891.

Leipzig, February 16.

W. OSTWALD.

### A Lecture Experiment on Sound.

The following experiment may be of interest to your readers. A piece of glass tubing is drawn out to a fairly fine point, P, attached by string crosswise to a short lath of wood, W, connected by india-rubber tube to water-tap, and a jet of water directed on to a tambourine, T.

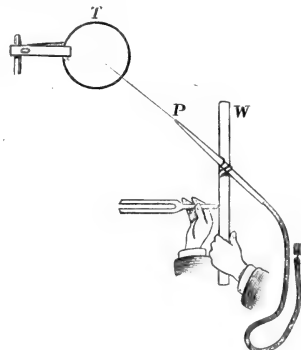

A tuning-fork held in one hand is made to touch the lath held in the other while vibrating, and the whole moved nearer to or further from the tambourine.

At a certain distance the note of the fork will be produced on the tambourine (this of course is not a new experiment). While this was going on, the lath, jet, and fork were slowly moved towards the tambourine, and I was able to sound the octave below.

This showed that at a certain point the vibrations of the fork were not individually capable of separating the fine stream into drops, but that two complete vibrations did so; thus half as many drops per second were set free as there were vibrations from the fork.

The fork gave  $C = 512$ ; the note on the tambourine was  $C = 256$ .

Probably the drops at that stage were of a dumb-bell shape—since at a greater distance the actual note of the fork was produced on the tambourine.

REGINALD G. DURRANT.  
The College, Marlborough, February 13.

### The Formation and Erosion of Beaches, &c.

As you have more than once permitted me to discuss the problem of sea-waves in your columns, I venture to point out that in your interesting article on Signor Cornaglia's work on sea beaches (p. 362), in your summary of the causes which affect beaches, sand-banks, &c., you have omitted the very important one of wind-raised surface currents. Sea-waves, tidal-currents, and river-currents can be observed, and their effects recorded; but it is the occasional, irregular, and sometimes powerful wind-raised current, prevalent during storms, which performs such erratic feats, and deludes the unwary observer. For instance, a beach may resist the sea for years, yet in a few hours it may be stripped bare to the solid rock. Shells may be covering the bottom a mile off shore, undisturbed by on-shore gales; a storm, with wind and waves apparently much the same as usual, may sweep them all on shore. One beach will be invariably kept clear of shells which will be found off shore, while

another beach will have a constant supply, and for no obvious reason.

The causes which affect the movement of sand and silt are so numerous, and their resultant effects so well balanced, that if one of the former be increased or diminished the combined result may be completely reversed. I have just come across an interesting instance. For more than twenty years I kept a 6-ton boat in the tidal harbour here, where, when at her moorings, she took the ground in all weathers twice a day without any damage whatever. Since the erection of the new harbour arm, the silt has been cleared out of the harbour, leaving a hard bottom, and the coxswain of the lifeboat informs me that a boat moored in my old berth sprung a leak in a few days and had to be removed. The mode of accumulation of sand on the Torre Abbey beach is also changed in character. I cannot but think that it is a pity experiments are viewed with disfavour. The Torquay inlet and harbour works were eminently adapted for reproduction in an experimental tank. The then local surveyor, who had practically planned the new works, was anxious to carry the experiments out. We had begun to consider the details of the tank, when my intended colleague told me that superior authority "did not favour" the idea, and it was useless to proceed further.

I am now informed by practical seafaring men that the present plan must ultimately be amended, and clearly at considerable cost. Whether this be so or not, the question could have been decided in a tank in a few minutes, at the cost of, say, £15. The experimental tank for waves playing upon beaches was the suggestion of the late Mr. W. Froude, C.E., F.R.S.; so it is no mere mad of an unprofessional outsider.

Southwood, Torquay, February 19.

A. R. HUNT.

#### Torpid Cuckoo.

In the last volume of NATURE (vol. xlv. p. 223) an account is given by "E. W. P." of a cuckoo which was brought up in a house, and which disappeared one day in November, and was found in the following March on a shelf in the back kitchen, "still alive, and asleep, with all its feathers off, and clothed only in down, the feathers lying in a heap round the body."

It is rather interesting to note that Aristotle, who firmly believed that some birds hibernate, seems to have come across cases of birds in a similar condition. In his "History of Animals" (Book viii., chap. xviii.), he says, "Many kinds of birds also conceal themselves, and they do not all, as some suppose, migrate to warmer climates; but those which are near the places of which they are permanent inhabitants, as the kite and swallow, migrate thither; but those that are farther off from such places do not migrate, but conceal themselves; and many swallows have been seen in hollow places almost stripped of feathers; . . . for the stork, blackbird, turtle-dove, and lark hide themselves, and by general agreement the turtle-dove most of all, for no one is ever said to have seen one during the winter. At the commencement of hybernation it is very fat, and during that season it loses its feathers, though they remain thick for a long while." I have adopted the translation in Bohn's edition. The italics are mine.

A. HOLTE MACPHERSON.

51 Gloucester Place, Hyde Park, W., February 22.

#### A Swan's Secret.

Now that the breeding-season for birds is coming near, it would be interesting to note if the following sight I saw last spring is common to swans. A pair of swans built on an island on the River Wey, which runs through our grounds, and I stood on the bank opposite their nest, and watched for a view of the cygnets, which were just hatched out. The male bird presently picked up an empty half egg-shell lying beside the nest, and carefully carried it to the edge of the water, some 20 feet from where the nest was built, and proceeded to fill it with mud, and then pushed it into the river, where it sank to the bottom. He then fetched the only other remaining piece of shell, and did the same. On returning to his nest the last time, he placed a few sticks across the small track he had made, as if to conceal his actions. Evidently this process had been done to each piece of shell, as no other pieces were to be seen, although five cygnets were hatched out.

JESSIE GODWIN-AUSTEN.

Shalford House, Guildford, February 22.

NO. 1166, VOL. 45]

#### A Simple Heat Engine.

MR. FREDERICK SMITH described in NATURE of January 28 (p. 294) a simple heating machine, which he constructed with a nickel disk, so that when heated before a magnet it began to revolve. A similar heating machine was shown by Prof. Dr. T. Stefan, Vice-President of the Imperial and Royal Academy in Vienna, in the course of a lecture to his students, among whom I was, in the year 1885. A memoir on it appeared in the publications of the above-named Society. The machine was thus constructed: nickel plates were fixed on a wheel, like that of a water-mill, and a magnet was placed before it. By heating a nickel plate before the magnet, it was repulsed by the magnet, and a succeeding plate was attracted, so that the wheel commenced to rotate.

So much I thought it necessary to communicate about the priority of such a heating machine.

KONSTANTIN KARAMATE.

Buccari next Fiume, Austria, Nautical School,  
February 18.

#### New Extinct Rail.

[Telegram.]

I HAVE just obtained from the Chatham Islands a nearly perfect sub-fossil skull of an extinct Ocydromine rail, closely resembling the Mauritian *Aphanapteryx*, five and quarter inches long, beak arched, slender, very pointed, for which I propose the specific name *Hawkinsi*.

HENRY O. FORBES.

Canterbury Museum.

#### ON A RECENT DISCOVERY OF THE REMAINS OF EXTINCT BIRDS IN NEW ZEALAND.

A DEPOSIT of moa bones, larger than has been found for many years, has just been discovered near the town of Oamaru, in the province of Otago, in the South Island of this colony. Their presence was indicated by the disinterring of a bone during the ploughing of a field, by the proprietor of which the circumstance was communicated to Dr. H. de Lautour, of Oamaru. This gentleman, who is well known through his papers on the diatomaceous deposits discovered by him in his district, at once inspected the spot. Finding that the deposit was large, he first secured, through the kindness of the proprietor, the inviolability of the ground, and then telegraphed the information to the Canterbury Museum. I lost no time in proceeding to Oamaru with one of my assistants, and superintended the digging out of the bones in a systematic manner. The site of the deposit was at Enfield, some ten miles to the north-west of the town, on ground elevated several hundred feet above the level of the sea, in a shallow bayleted hollow, into which the unbroken surface of the expansive slope gently descending from the Kurow hills to the open vale of the Waireka (a stream that rises further to the west) has sunk here for some 7 to 8 feet below the general level, and which, proceeding with a gentle gradient valleywards, becomes a ditch-like conduit for a tributary of the Waireka. In the centre of this depression, which does not exceed 10 to 12 yards in width, the ground was of a dark brown colour, damp and peaty. On removing the upper layer of soil for a depth of 3 to 4 inches round where the bones had first been brought to the surface, and whereon was strewn abundance of small crop-stones, a bed of very solid peat was reached, and firmly embedded in it were seen the extremities of numerous *Dinornis* bones, most of them in excellent preservation, though dyed almost black. Further digging showed that certainly many of the skeletons were complete, and had been but slightly, if at all, disturbed since the birds had decayed. Owing, however, to the close manner in which they were packed together, and especially in which the limbs were intertwined, it was rarely possible to extricate the bones in the order of their relations, or to identify with certainty the various bones of the same skeleton, each bone having to be extracted as

the circumstances of the moment directed. In many cases, again, only the pelvis and femora could be traced *in situ*, the vertebrae and remaining leg-bones being indistinguishable in the general agglomeration. It seemed evident that the birds had not died in an erect posture, but more probably with their limbs bent under them or in the same plane with the body. In some instances, beneath the sternum were found, lying quite undisturbed, the contents of the stomach, consisting of more or less triturated grass mingled with crop-stones. The quantity of these smoothed, rounded (chiefly white quartz) pebbles—in size from about that of a bean to that of a plum—mingled with the bones was enormous, and would, if collected, have formed more than a cart-load. Except where the bones were, there were no pebbles of any sort, no small stones nor even sand, anywhere around. The nearest place where pebbles of the same composition are to be found is, I was informed, several miles distant.

Four trenches, or pits, in all, were sunk. The dimensions of the first, which was excavated entirely in peat, did not exceed 3 feet square and  $3\frac{1}{2}$  to 4 feet in depth. When it was exhausted of its treasure, a second search was made about 20 to 25 feet higher up the hollow. The dimensions of this pit extended to about 7 feet square and to the same depth as the first. Two more trenches, a few feet apart, were dug at about 30 yards still further up the depression. They were not so large as the other two, but they extended down to about the same depth,  $3\frac{1}{2}$  to 4 feet, the bottom of both being (as it was in the second) a bluish clay, with which, in the pit furthest up, was sparingly mingled a small deposit of the finest silt. In the first pit portions of both *Cnemioornis* and *Harpagornis* bones were found in abundance, and remains of several hundreds of moas of all ages. It was from the second pit, however, that the largest deposit of moa bones was obtained, and the most perfect specimen of food remains from beneath a sternum. Here, also, numerous bones of the giant buzzard and of the great extinct goose were exhumed, and a cranium as large as, if not slightly larger than, that of *Cnemioornis*, but of a species with complete bony orbits, as in the Cape Barren goose, and indistinguishable from *Cercopsis*. Bones from other parts of New Zealand, now in my possession, which I hope shortly to describe, indicate with certainty that several species of *Cnemioornis* formerly existed in this colony. Some of these bones are remarkable for their slender elegance, and indicate species less in size and lighter in build than *Cnemioornis calcitrans*. Among the bones so far examined, I have observed no remains of *Aptornis*, of *Ocydromus*, or of *Notornis*; but I possess an adult tibia of a rail smaller than *Porphyrio melanotus*, yet larger than any other existing New Zealand species. The tarso-metatarsus of a species of *Anas*, about the size of *Anas fuscus*, the metatarsus and sternum of *Apteryx Oweni*, and crania of *A. australis*, are among the bones recovered at Enfield, in addition to the metatarsus of a *Biziura*, somewhat larger than *Biziura lobata*, the musk duck of Australia, an interesting species for which I have proposed the name of *Biziura de Lawtouri*, after the gentleman to whom I am indebted for the acquisition of these bones. There are still other bones which I have not yet been able to identify. The *Dinornis* remains belong chiefly to the species *elephantopus* (of unusually large proportions), to *ingens*, and to *rheides*. Very fine specimens of pelvis and sterna have been obtained, with numerous crania more or less perfect. In this second trench the excavation penetrated through the peat into a bluish clay charged with water (which was, indeed, reached in all the diggings at about 4 feet below the surface), and into this clay the bones just protruded, but no more. The osseous remains dug from the last two holes belonged to the same species as those from the others. Digging and probing the ground beyond the boundaries of the trenches showed us that we had exhausted their contents; while the probing of

the ground in the neighbourhood for a considerable radius around, and in other peaty spots not far off, failed to afford indications of other deposits. The number of perfect femora of *Dinornis* brought away exceeded 600; a large number were so decomposed as to fall to pieces in the handling; while a great many others disintegrated, after removal from the ground, on exposure to the atmosphere. I believe I do not over-estimate, therefore, in saying that from 800 to 900 moas at least were entombed in this shallow hollow. So many moas (leaving out of the reckoning the other species of birds) could not by any possibility have found standing-room, however crowded together, in the entire area of the depression. It would appear evident, therefore, that they did not perish all at one time. To account for their burial in such numbers in areas so circumscribed seems to me at present impossible. That their bodies were entire when they were deposited is clear, from the presence in such abundance of the crop-stones, from the position of the bones, and from the finding of the intact contents of the gizzard. No stream of any size could find origin in the immediate neighbourhood, and no stream which could have transported the entire carcasses of birds of such huge proportions as *Dinornis ingens* or *D. elephantopus* could ever have occupied this ravine-head without leaving traces of its action on the surface which would be visible to-day, or without washing away the very fine silt mixed with the clay on which the bones lie, in the bottom of the most upland of our excavations. None of the bones are waterworn. This little hollow was, in the early days of its present proprietor, very wet and boggy, and several springs have origin in it. If the moas made this a highway from one part of the country to another, it seems difficult to believe that birds so powerful of limb, and standing at least 10 to 12 feet in height, could stick fast in so shallow a bog; and to conjecture why eagles of powerful flight, slender rails, small ducks, and comparatively light-footed kiwis also should become ensnared. Driven by fire in the surrounding bush—which may have covered the country then, for the plough has, I am informed, brought to light the stools of many large trees at no great distance, while logs of wood were found among the bones—did they, in a struggle for life in a narrow space, trample each other to death? The presence of the strong-winged *Harpagornis* in considerable numbers seems to militate against this explanation, and no calcined bones have been discovered. An explanation offered some years ago, to account for the presence of a great number of moa and other bird bones in a somewhat similar situation in the Hamilton swamp—that during severe winters these birds congregated at the springs rising warmer from below, and were overtaken by a severe and fatal frost as they stood in the water—appears unsatisfactory in the present case, as there are numerous springs and equally boggy ground near at hand, round which no remains can be found, and so close to the sea such excessive frosts are now unknown. That these were individuals who, during an excessive drought, arrived at the springs too far exhausted to revive—an occurrence common enough in Australia—and that the water there was charged with poison, have also been offered as explanations. But the permanence of glacier rivers, highest in the hottest seasons, precludes the idea of animals dying of thirst in this island, or at all events in this locality so near to the great snow river Waitaki. Poisoned water-holes or exhalations of carbonic acid might be a sufficient reason, yet in those springs elsewhere where bones have been found chemical analysis has failed to detect any substance harmful to life in their waters at the present day. Not a single indication of human intervention was observed. No bones were discovered which had been broken in their recent state; neither kitchen-middens, nor remains of ovens or of native encampments, occur anywhere near the deposit.

One piece of egg-shell dug out of the highest trench is not sufficient evidence on which to base the supposition that the spot was frequented as a nesting-place.

At Glenmark, in the north of this province, the historic spot where the original (somewhat larger than the present) find of *Dinornis reliqua* was dug out by my predecessor, the late Sir Julius von Haast, the bones of numerous species of birds besides moas were found. Their occurrence in the situations where they were discovered, and the way in which they were lying—entire bodies with their sterna covering crop-stones *in situ*—have been explained by the supposition that the moas were overtaken by a fierce and sudden storm, and their entire carcasses piled by wind and flood into vast heaps, an explanation against which the presence here also of the same powerful buzzard and other flying birds rises as an objection. Yet there is nothing either in the situation or the disposition of the bones to make it impossible; still I cannot help feeling that that cannot be the true explanation which satisfies only one instance out of so many assemblages of dead birds of nearly always the same species in situations almost similar. I hope, however, that when I have made a thorough examination of all the localities where, and the conditions under which, moa remains have been found, in the light of the personal experience gained in the exhumation of the present deposit, and when I have completed the identification (on which I am now engaged) of the smaller bird bones associated in them with the moa bones, some light may have been gained on this at present mysterious episode in the history of the ancient Avians of New Zealand.

HENRY O. FORBES.

Christchurch, New Zealand.

#### THE BLUE HILL METEOROLOGICAL OBSERVATORY.<sup>1</sup>

THE *Annals* of this high class Meteorological Observatory for 1890 are of more than usual interest, since we have here presented not only the observations of the year, which are made with remarkable fullness and exactness, but also a well presented and discussed *résumé* by Mr. Clayton for the lustrum ending with 1890, together with an account of the hourly and other observations made at the Signal Service Station at Boston. The Observatory is situated about ten miles south of Boston, on the summit of a peaked hill 640 feet above the sea, and as the ground falls down from the buildings in every direction for several hundred feet, the Observatory occupies a unique position among Observatories in the investigation of some of the more important phenomena of meteorology.

The hourly means of atmospheric pressure show for all the months the double tide well marked. The chief maximum steadily recedes from 10 a.m. in winter to 8 a.m. in summer, and the chief minimum advances from 2 p.m. in winter to 5 p.m. in June. The evening maximum shows a slight tendency towards displacement in the same direction as the afternoon minimum, and the night minimum a similar displacement in the same direction as the morning maximum. A third barometric maximum, which is generally met with in middle latitudes, is particularly well marked at this place.

But the important position of this Observatory appears in the most striking manner on comparing the hourly barometric results of 1890 from the Blue Hill with those from Boston for the same year. The Blue Hill Observatory is situated on a true peak, but the station at Boston is in the mouth of the rather broadish valley which stretches northward from the town. The result is that,

though the places are only about ten miles apart, the diurnal fluctuation at Boston is 0.017 inch greater than on the top of Blue Hill. In June, when this feature of the pressure is at the annual maximum, the following are the hourly results, where the plus sign indicates that pressure at Boston rose above its daily average by these amounts, expressed in thousandths of an inch, greater than did pressure on the Blue Hill above its daily average; and the minus sign that it fell lower by these amounts at the former than at the latter place.

	Diff.		Diff.		Diff.
1 a.m.	+ 2	9 a.m.	+ 6	5 p.m.	- 5
2 "	+ 3	10 "	+ 1	6 "	- 7
3 "	+ 8	11 "	- 1	7 "	- 5
4 "	+ 10	Noon	- 4	8 "	- 8
5 "	+ 10	1 p.m.	- 3	9 "	- 5
6 "	+ 10	2 "	- 5	10 "	- 4
7 "	+ 7	3 "	- 5	11 "	- 2
8 "	+ 6	4 "	- 7	Midnight	- 1

The explanation is that, during the night, cold air-currents flow down the sides of a valley and accumulate below, and thus a higher pressure is maintained in valleys during the night; but, on the other hand, during the day the valleys become more highly heated by the sun, and under the strong ascending currents thereby generated, pressure falls lower than in open situations. The amounts increase in proportion to the daily range of temperature, and as the mean velocity of the wind diminishes. This diurnal variation is greatest in the deep valleys of Switzerland and other mountainous regions, and, though small in amount is a well-defined and steady fluctuation in the valley of the Thames, as shown by a comparison of the Kew and Greenwich barometers. A weak point in the meteorological publications of the Signal Service of the United States is the all but complete absence of the results of the hourly phenomena of meteorology. In filling up this hiatus, the Blue Hill Observatory will prove of the greatest service, as offering a truly normal Observatory, at which, from its mere position, several disturbing elements affecting diurnal phenomena are eliminated.

During the whole year, the time of occurrence of the minimum temperature is very near sunrise; and it is interesting to note that the maximum occurs at all seasons from 2 to 3 p.m., approaching in this respect the time of the maximum at truly high-level Observatories, or at Observatories situated on peaks. For the five years, the mean monthly temperatures deduced from the maximum and minimum thermometers exceed those deduced from the hourly values every month, the smallest excess being 0.2 in December, and the largest 1.2 in August, the mean for the year being 0.7.

The prevailing winds are north-westerly from February to April, southerly in May, and westerly and north-westerly for the other months. These winds are ruled by the different distributions of atmospheric pressure over the Atlantic and America in the respective months; these being in winter the low pressure round Iceland, and the high pressure over the United States and Canada; and in summer the high pressure in mid-Atlantic, together with the low pressure over the Middle States. The hourly frequency of each wind has been worked out for the lustral period, with results that are very suggestive. The period is sufficiently extended to give fairly good averages, from which accidental phenomena may be regarded as eliminated; and the result is more completely attained by the height of the Observatory above the surrounding country all round removing from the observations the more purely local causes of disturbance. The mean hourly frequency of each wind shows a clear tendency of the wind to veer around the compass each day. Thus, the greatest frequency of southerly winds occurs at 8 p.m., south-westerly at 10 p.m., westerly at 1 a.m., northerly at

<sup>1</sup> "Annals of the Astronomical Observatory of Harvard College," vol. xxx., Part 2, "Observations made at the Blue Hill Meteorological Observatory, Mass., U.S., in the Year 1890, under the direction of A. Lawrence Rotch, Esq." With Appendices. (Cambridge: University Press 1891.)

5 a.m., north-easterly at noon, easterly at 2 p.m., and south-easterly at 7 p.m., and this occurs winter and summer, and is independent of the sea breeze.

This points plainly to a cause in daily operation, which the unique position and work of the Blue Hill Observatory enable us to deduce from a comparatively few years' observations. This cause is the diurnal barometric tide, with its two maxima and minima, which, as regards the Blue Hill, are more pronounced over the land to westward than over the ocean to eastward, and become still more pronounced on advancing southward into lower latitudes and westward into more inland situations. Thus, at 9 a.m., the time of the morning maximum, pressure at the Blue Hill is 0'023 inch above the daily mean; at New York, 0'028 inch; at Philadelphia, 0'031 inch; and at Washington, 0'035 inch. Now at this physical instant, 9 a.m. local time, this atmospheric tide becomes relatively less and less on advancing eastward across the Atlantic, and at New (about 2 p.m. G.M.T.) pressure is 0'012 inch below its average. From its position with respect to this wide-spread shallow diminution of pressure, northerly and north-easterly winds attain their diurnal maximum frequency at this hour. Again, at the Blue Hill, pressure falls to the daily minimum at 3 p.m. (local time), after which it continues slowly to rise; and, while rising, pressure is relatively lower to the westward. From its position in the north-easterly segment of this wide-spread area of lower pressure, the south-easterly winds at the Blue Hill attain their daily maximum frequency at 3 p.m.

The mean maximum velocity of the wind, about the rate of twenty-two miles an hour, occurs from November to March, and the minimum, nearly fifteen miles an hour, from June to August. As regards the hourly velocity of the wind, the records show the occurrence of the daily maximum at 3 p.m., being the hour of occurrence generally, except at high-level Observatories; but the time of the minimum, 8 a.m., is markedly different. This peculiarity arises from the curious but highly interesting fact that the Blue Hill shows a secondary maximum immediately after midnight, or the time when the daily maximum velocity occurs at high-level Observatories, thus linking the Blue Hill Observatory with both high and low level Observatories.

There are also published valuable results of humidity, cloud, sunshine, rain, gales, thunderstorms, and visibility of distant objects, for which we must refer to the Report itself. As the Meteorological Service of the United States has recently taken a new departure, it is to be hoped that Mr. Rotch, who has generously established this Observatory, and has its admirable work well in hand, will yet see his way to the continuance of the tabulation and publication of the hourly values of the elements, which cannot but prove to be of essential service to the Department in carrying out certain developments of American meteorology which, it is understood, are under consideration.

#### GUSTAV PLARR.

ONE of the older generation of mathematicians has lately passed away in the person of Dr. Gustav Plarr, who died at Tonbridge on January 11, of bronchitis following influenza. He was born on August 27, 1819, at Kupferhammer, a country house near Strasburg. He was educated at the Gymnase and at the University in that city, whence he proceeded to Paris University, where he obtained his diplomas as Licentiate of Sciences and as "Docteur ès Sciences Mathématiques." Among his close friends at school and at the University was M. Wurtz, while M. Gerhardt, another great chemist, was among his Strasburg contemporaries. Dr. Plarr for some time meditated a life of chemical research, but found that his health would not permit of prolonged

laboratory work. After taking his doctorial degree, he was for some time mathematical master at a College at Colmar, and, on the Chair of Mathematics becoming vacant in the University of Strasburg, was one of the candidates for the post. He was strongly supported by the Strasburg academic party, especially by M. Sarrus, the outgoing Professor, but clerical influences were at work against him, and a Parisian was finally imposed on the little Germanizing University.

In 1857, Dr. Plarr married an English lady, and during his honeymoon in Dublin was introduced to Sir William Rowan Hamilton, the originator of the Quaternion method, and became thenceforth a devoted student and exponent of the work of that great genius.

The British Association met at Dublin in the autumn of 1857, and Dr. Plarr was one of the eight foreign men of science who were that year elected "Corresponding Members." Whewell, Hamilton, Vignoles, and Brewster were, we believe, his sponsors on this occasion. The paper then communicated by him to the Mathematical Section of the Association will be found at p. 101 of the Report.

The other seven men of science elected at this meeting were Barth, Bolzani, d'Abbadie, Loomis, Pisani, and the two Schlagintweits. Of these, only Herman Schlagintweit survives. Indeed, at the time of his death, Dr. Plarr was one of the half-dozen oldest living "Corresponding Members" of the British Association.

In the Franco-German war of 1870, Kupferhammer was burnt by the French, in order to dislodge Prussians who had been able thence to command the sluices of the moat round Strasburg. Dr. Plarr accordingly came to reside among his wife's relatives, first at St. Andrews, and then at Tonbridge.

Since 1870, Dr. Plarr's time was almost exclusively devoted to the study of Quaternions. In 1882-84 his French translation of Prof. Tait's Treatise was published by Gauthier-Villars. Several papers by him, on abstruse points connected with the Quaternion method, were communicated to the Royal Society of Edinburgh. Beside these there is a very interesting piece of ordinary analysis connected with Spherical Harmonics.

Modest, unambitious, studious, simple in his habits to the verge of asceticism, Dr. Plarr was of a type rare in these days and in this country. Although a man of wide scientific culture, and of many literary interests, he was content to be a pioneer in a realm of thought for which there is necessarily no popular sympathy at present. Quaternions, indeed, were to him the mathematics of the future, and he was to the last happy in the thought that he had assisted, however obscurely, in their development.

#### NOTES.

Two international scientific Congresses are to be held at Moscow in August. One will relate to anthropology and archæology, the other to zoology. There will be exhibitions in connection with both Congresses, and appeals have been issued for the loan of objects which are likely to be useful and interesting. Among the things wanted for the Anthropological Congress are phonograms of the language and songs of different races. French will be the official language of the two meetings. The more important papers will be printed before members come together, so that discussion may be facilitated.

THE death, on February 20, of Prof. Hermann Kopp is announced. He died at Heidelberg, after a long and painful illness, in the seventy-fifth year of his age.

THE well-known botanist and philologist Stephan Endlicher was buried in 1849 in a churchyard near Vienna. This churchyard is about to be closed, and it is proposed that Endlicher's remains shall be removed to the new central cemetery

of Vienna, and that a suitable monument to him shall there be erected. At present, his grave is not marked even by an ordinary tombstone. An influential international Committee has been formed for the purpose of giving effect to the scheme. Those who desire to associate themselves with it should send subscriptions as soon as possible to the K.K. zoologisch-botanische Gesellschaft, Vienna, I, Herrengasse 13.

MR. W. SAVILLE-KENT, who has been absent from England during the past eight years, acting in the capacity of Inspector and Commissioner of Fisheries to various of the Australian Colonial Governments, and most recently to that of Queensland, is now in London, and will be occupied for the next few months, chiefly at the British Museum, South Kensington, in working out the corals and other natural history materials collected by him on the Great Barrier Reefs. Associated with the materials in question is an extensive series of photographs of coral reefs and coral animals taken from life, some few of the more early acquired of which were exhibited at last year's *conversazione* of the Royal Society. Selections from the completed series will be shortly published in association with a work, on the fishery and natural history products generally of the Great Barrier district, that Mr. Saville-Kent has in preparation. Mr. Saville-Kent is under engagement with the Government of Western Australia to proceed to that colony towards the end of the current year, to investigate and report upon the pearl and pearl-shell, oyster, and other indigenous fisheries, with a view to their more profitable development. This engagement is likely to occupy him for some two years, when he proposes to return permanently to England.

PROF. HUXLEY AND PROF. RAY LANKESTER have each written to the *Times* on Lady Blake's proposal that a marine biological station should be established in Jamaica as a memorial to Columbus. Prof. Huxley points out that "animal life is indescribably abundant and varied in the intertropical seas," and hopes that the scheme will meet with cordial support here and in the United States. Prof. Ray Lankester is also of opinion that a good permanent laboratory for the study of marine life should be established in the tropics; and he thinks that "no position is more favourable for this purpose than the coasts of Jamaica." He urges, however, that a definite set of proposals should be made in Jamaica for the realization of the Columbus Laboratory. His opinion is that "the Government of Jamaica should initiate the scheme, and make the proposed laboratory part of a biological and physical survey of the coasts of the island." What is chiefly needed is "an efficient, well-trained naturalist, who must be paid at least £700 a year for his services (less than a lawyer or a sanitary officer), and a Government gunboat with crew, &c., and two or three special fishermen and attendants." A suitable building, Prof. Lankester thinks, could easily be obtained.

The members of the Geologists' Association will make an excursion to Hornchurch on Saturday, March 5, Mr. T. V. Holmes acting as director. They will visit sections on the new railway between Upminster and Romford. The early date of the excursion has been rendered necessary by the state of the most important section. The first cutting to be visited is that between Upminster Station and the Ingrebourne. It shows London Clay capped by gravel and loam belonging to the highest terrace of the Thames Valley deposits in this district. Crossing the Ingrebourne, the line enters another cutting northeast of Hornchurch. In this cutting boulder clay has been seen for a distance of 300 yards, resting in a slight hollow on the surface of the London Clay, and capped by gravel belonging to the highest terrace of the Thames Valley beds. The greatest thickness of boulder clay seen in this cutting is 15 feet, and it is hoped that the sloping now going on may not have advanced so

far at the date of the excursion as to have destroyed every clear section. At Butts Green there is a good section of London Clay capped by sand and gravel. Nearer Romford the cuttings are not sufficiently advanced to be worth visiting. The total walking distance is three miles.

A WORK of considerable interest to meteorologists has been published in the *Memoirs of the Physical Society of Geneva*, containing the detailed observations made under the directions of H. B. de Saussure on the *Col du Glant*, at Geneva, and at Chamounix simultaneously, from July 5 to 18, 1788. The means only, and these only for a part of the observations, were published in his "Voyages dans les Alpes" (Neuchâtel, 1779-86). These valuable observations, which have been carefully revised by his grandson, Henri de Saussure, have often been asked for, and we believe have only lately been discovered. They include values taken several times daily of pressure, temperature, humidity, wind, cloud, electricity, magnetism, &c., together with general remarks upon the weather.

FROM a recent statistical study of the wheat harvests of Ohio (summarized in *Science*), it appears that the average yield of wheat is increasing in the northern and central sections of the State, while it is at a standstill, and at far too low a point for profit, in the southern and south-eastern counties. Geologically, there are three bands running across the State from north to south—that in the east (nearly a third of the whole), over coal-measures; next to it, a narrower strip of Waverly rocks (sandstones and calcareous shales); then the western half, over limestones. The two latter are covered with a bed of glacial drift, which is, however, a good deal modified by the underlying rocks. In the northern portion, the counties over the Waverly rocks show a larger average yield (in forty-four years) than those over limestones and the coal-measures, and they also show a higher rate of increase. In the middle and south, the limestone counties show the larger yield; and in the middle (not the south), the larger rate of increase. The counties over the coal-measures are inferior in yield per acre in each belt, the difference increasing as we come south. The hilly character of the ground is supposed to be the chief cause of this lower yield. Some 48 million bushels were harvested in Ohio in 1888. The area devoted to wheat is approaching 3 million acres, and represents 12 per cent. of the area in farms in the State. The average yield is thirteen bushels per acre (in England it is about twenty-eight bushels), but in the northern and middle parts it is steadily growing. The production is keeping far ahead of any possible consumption within the State.

AN important Conference of fruit-growers was held last year in Sydney, the chair being occupied by the Hon. Sydney Smith, Minister of Mines and Agriculture in New South Wales. It lasted several days, and the report of the proceedings, which has now been issued, ought to be of great service to fruit-growers in all parts of the colony. The President, in his concluding speech, said the Government were both proud and anxious to assist the agriculturists of the country. All that was required was the co-operation and assistance of those engaged in the industry, in order that they might know in what direction this assistance would be most useful. He felt sure a great deal of good would come from the discussions during the Conference, and he hoped the members would hold Conferences in their own districts. He was most anxious to see the local Agricultural Societies holding meetings every month, where papers could be read and different important questions discussed, as he was certain this would do good, and he sincerely hoped his suggestion would be acted upon, as they might rely upon the assistance of the Department. The Government, as they knew, had already granted pound for pound to the Agricultural Societies, and they were willing to do

still more. On that year's estimates £5000 was set apart for national prizes throughout the whole colony, and he believed these prizes would be worth winning.

THE prevalent notion that the mistletoe is injurious to the apple or other tree on which it grows is disputed by Dr. G. Bonnier, the Professor of Botany at the Paris Sorbonne, who maintains, not only that this is not the case, but that it is actually beneficial to its host, the relationship being not one of simple parasitism, but rather one of symbiosis. He determined from a series of observations on the increase in the dry weight of the leaves, that, while in summer the mistletoe derives a large portion of its nutriment from the host, in winter these conditions are reversed, and the increase in weight of the mistletoe is less than the amount of carbon which it has obtained from the atmosphere—in other words, that it gives up to its host a portion of its assimilated substance.

AT a meeting of the Royal Botanic Society on Saturday last, Dr. R. C. A. Prior presented ripe seeds of *Araucaria imbricata*, the monkey-puzzle tree of Chili, collected from a large tree growing in the open air at Corsham, Wilts. He mentioned that in this country the plant, though common, seldom ripens its seeds. It was first introduced here 100 years ago by Mr. Menzies, a Scotch botanist, who accompanied Vancouver's expedition in search of a passage between the Atlantic and Pacific Oceans. In returning from their attempt they put in at Valparaiso, and were hospitably entertained by the Viceroy of Chili. While dessert was on the table Menzies observed some nuts he had not seen before. Instead of eating his share he saved them, and, taking a box of soil back with him on board ship, succeeded in raising five plants, which he brought to England, and these formed the stock from which most of the large trees now growing in various parts of the country have sprung.

SOME time ago Mr. G. Brown Goode, of the U.S. National Museum, delivered before the Brooklyn Institute a lecture on "The Museums of the Future." This lecture has now been printed, and is well worth reading. Mr. Goode's main idea is, that "the people's Museum should be much more than a house full of specimens in a glass case." "It should," he says, "be a house full of ideas, arranged with the strictest attention to system." This conception he expresses epigrammatically by defining a Museum as "a collection of instructive labels, each illustrated by a well-selected specimen." In the course of the lecture he offers many instructive and interesting remarks on the Museums of the Old World.

THE first number of the new *Zeitschrift für Anorganische Chemie*, edited by Prof. Krüss, of Munich, was issued on February 27. As its title implies, the new journal is devoted exclusively to the inorganic branch of chemistry, and the names of the distinguished chemists throughout Europe and America whose co-operation the editor has been fortunate in securing would appear to promise well for its value and success. The first number, now before us, contains the following six original memoirs: "Phosphorus Sulphoxide," by T. E. Thorpe and A. E. Tutton; "The Double Acids of Hepatometric Iodine," by C. W. Blomstrand; "The Action of Hydrogen Peroxide upon certain Fluorides," by A. Piccini; "Ammoniacal Platinum Compounds," by O. Carlgren and P. T. Cleve; "Preparation of Tungstates free from Molybdenum," by C. Friedheim and R. Meyer; "A Lecture Experiment," by C. Winkler.

A NEW *Physical Review* has been started by the publisher J. Engelhorn, of Stuttgart. The editor is L. Graetz. The object of this periodical will be to make German readers acquainted with the work being done by physicists in other countries. It is intended that it shall serve as a sort of supplement to the well-known *Annalen der Physik und Chemie*.

WE are glad to welcome the first number of *Natural Science*, a monthly review of natural history progress. The object of the editors will be "to expound and deal in a critical manner with the principal results of current research in geology and biology that appear to be of more than limited application." Articles are contributed to the first number by Mr. F. E. Beddard, Mr. J. J. H. Teall, F.R.S., Mr. A. S. Woodward, Mr. R. Lydekker, Mr. J. W. Davis, Mr. G. A. Boulenger, Mr. J. W. Gregory, Mr. G. H. Carpenter, and Mr. Thomas Hick. The publishers are Messrs. Macmillan and Co.

MESSRS. EASON AND SON, Dublin, will issue in April the first number of the *Irish Naturalist*, a monthly journal of general Irish natural history, and the official organ of all the natural history Societies in Ireland. The editors will be Mr. George H. Carpenter and Mr. R. Lloyd Praeger.

A NEW instalment (vol. i. No. 10) of the *Records of the Australian Museum* has been issued. These *Records* are edited by Dr. E. P. Ramsay, Curator of the Museum, and embody the results of a great deal of serious scientific work. The present number contains the following papers:—"On the Occurrence of the Genus *Palaeaster* in the Upper Silurian Rocks of Victoria," by R. Etheridge, Jun. (plate); "The Operculate Madreporaria Rugosa of New South Wales," by R. Etheridge, Jun.; "Notes on the Structure of *Pedionomus torquatus*, with regard to its Systematic Position," by Dr. Hans Gadow.

MESSRS. BLACKIE AND SON have issued an enlarged edition of the well-known "Concise Dictionary of the English Language," by Dr. Charles Annandale. The new matter consists partly of a supplement giving definitions of additional words, partly of several new appendices or lists for general reference.

THE General Report of the operations of the Survey of India Department, administered under the Government of India during 1889-90, has been issued. It has been prepared under the direction of Colonel H. R. Thuyllier, R.E., Surveyor-General of India. The Report relates to trigonometrical, topographical, forest, cadastral, and traverse surveys. There is also an account of electro-telegraphic longitude operations, tidal operations, and geographical surveys and reconnoissances.

THE following are the arrangements for science lectures at the Royal Victoria Hall during March:—March 1, Dr. W. D. Halliburton, on "Nerves"; March 8, Prof. Reinold, on "Sound and Music"; March 15, Dr. Tempest Anderson, on "Iceland"; March 22, Prof. Weldon, on "Soles and other Sea-Fishes"; March 29, Mr. A. Smith Woodward, on "Elephants."

A PAPER upon the preparation of amorphous boron is contributed by M. Moissan to the current number of the *Comptes rendus*. It was shown in a communication to the Académie des Sciences upon February 15 that the substance hitherto regarded as amorphous boron is a mixture of that substance with large quantities of impurities, formed by the combination of the boron at the moment of its liberation with a portion of the metal used to replace it and with the substance of the vessel in which the reaction is performed. M. Moissan now describes a method by which he has succeeded in obtaining boron in a state of almost perfect purity. The reaction which he employs is that of metallic magnesium upon boric anhydride, a reaction previously studied by several observers, and most recently by Prof. Winkler, who employed the magnesium in the quantity calculated to remove all the oxygen from its state of combination with the boron. M. Moissan shows that if only one-third of this quantity of magnesium is employed, the yield of free boron is very much enhanced, and the impurities are only such as can be removed. He confirms Prof. Winkler's statement that two borides of mag-

nesium are capable of formation, one of which is unstable, and, as shown by Messrs. Jones and Taylor, is decomposed by water with evolution of a mixture of hydrogen and boron hydride, while the other is permanent both in the presence of water and acids. It is this stable boride, which M. Moissan has obtained in good crystals, which is so difficult to remove from the substance which has hitherto been considered as amorphous boron, and its formation should be avoided as much as possible. When magnesium and boric anhydride in the proportions above indicated—convenient quantities being 70 grams of the former and 210 grams of the latter—are heated to redness in a closed crucible, a somewhat violent reaction occurs, the crucible becoming vividly incandescent. Upon cooling, a reddish-brown mass is found, which is readily detached from the crucible, and is impregnated throughout with crystals of magnesium borate. The interior portion is then powdered, and successively treated with water and hydrochloric acid, alcoholic potash, hydrofluoric acid, and lastly with distilled water. This product, even after such exhaustive treatment, upon drying *in vacuo*, is found to contain only 95 per cent. of boron. In order to remove the 5 per cent. of the stable boride, the product is again heated to redness in the midst of a large excess of boric anhydride, and the extraction and washing repeated as before. The percentage of boron is by this means raised to 98·3 per cent., the remaining impurity being a mere trace of the boride and 1·3 per cent. of nitride of boron. These remaining impurities have finally been eliminated by employing a crucible rendered impenetrable to the furnace gases, the nitrogen of which rapidly causes the formation of nitride, by means of a mixture of titanous acid and charcoal. In addition to the laborious method above indicated, by which tolerably large quantities of pure boron may be obtained, M. Moissan further shows that it may be prepared in smaller quantities by the reduction of boric anhydride by magnesium in a stream of hydrogen, when, after extraction, a pure product necessarily free from nitride is obtained. And lastly, M. Moissan describes an electrolytical method of preparing it. Fused boric acid is rendered a good conductor of electricity by the addition of 20 per cent. of its weight of borax. Upon passing through the fused mixture a current of 35 amperes, a little sodium is liberated at the negative pole, and combines with the platinum electrode to form an alloy, while amorphous boron and oxygen are liberated at the positive pole. The greater portion of the boron, owing to the high temperature of the reaction, recombines with the oxygen with most brilliant incandescence, but a portion escapes combination, and may be isolated in the pure state as a chestnut-coloured powder.

THE additions to the Zoological Society's Gardens during the past week include a Green Monkey (*Cercopithecus callitrichus* ♂) from West Africa, presented by Mr. George W. Bowles; a Toque Monkey (*Macacus pileatus*) from Ceylon, presented by Mr. Arthur Wallis; a Bauer's Parrakeet (*Platyercus sonarius*) from South Australia, presented by Mr. Edward F. Baillou; two Alpine Accentors (*Accentor collaris*), European, presented by Lord Lilford, F.Z.S.; four Coqui Francolins (*Francolinus coqui* 2 ♂ 2 ♀) from South Africa, presented by the Hon. F. Erskine; a Green Toad (*Bufo viridis*), six Painted Frogs (*Discoglossus pictus*), European, three Moorish Toads (*Bufo mauritanica*) from Tunis, purchased.

#### OUR ASTRONOMICAL COLUMN.

THE WARNER OBSERVATORY.—“The Warner Observatory is distinctively a private institution built for the purposes of original discovery rather than the ordinary routine work of most other Observatories.” This sentence begins a recently-published history and work of the Warner Observatory, Rochester, N.Y., from 1883 to 1886. Under such favourable conditions as these,

it is not wonderful that a considerable amount of work should be done. Mr. Lewis Swift is the Director of the Observatory, and, upon assenting command, he selected the discovery of new nebulae as his principal field of labour. The first unrecorded nebula was found on July 9, 1883. Since then more than 400 others have been detected; and their positions and descriptions have been published from time to time in four catalogues. The observations are now brought together, and will therefore be more useful than heretofore. In the volume containing them are printed the Warner prize essays. One of these, by Prof. Lewis Boss, treats of “Comets: their Composition, Purpose, and Effect upon the Earth”; and there are several others on the coloured skies seen about the time of the Krakatō eruption. Mr. Henry Maine endeavours to show that a physical connection existed between these red sunsets and solar activity. The Rev. S. E. Bishop, of Honolulu, also describes the brilliant glows in question; ascribing them to the introduction of finely divided matter into the higher regions of the atmosphere.

MEASUREMENT OF SOLAR PROMINENCES.—In *Comptes rendus*, tome cxlii. p. 353 (1891), M. Fizeau pointed out that the velocities attained by solar prominences were comparable with the earth's orbital velocity, and remarked that, on account of this circumstance, prominences must suffer a displacement from their true position. If this were so, and the argument appeared to be sound, then the apparent heights reached would have to be increased or diminished according to the velocity with which the prominences were projected. Mr. Henry Crow has pointed out an apparent error in this reasoning (*Astronomy and Astro-Physics*, January, p. 90). He says:—“The author here neglects the fact that, at any given instant, each point of the solar disk and of the prominence, whether in motion or at rest, is sending to the observer rays, all of which are affected by the same correction for aberration. I say the ‘same’ correction, since the change in celestial longitude or latitude from one part of the sun's surface to another would affect the aberration quite inappreciably. If there be relative motion among the parts of the prominence, then, since at any instant aberration affects all these parts to the same extent, the prominence will be projected upon the slit of the spectroscope in its true proportions.” So the study of the solar surface is apparently not to be complicated by the introduction of a new correction. In this connection it may be remarked that, in a letter dated February 12, Prof. Hale writes: “You may be interested to know that I have just succeeded in photographing all the prominences around the sun with a single exposure.”

#### THE AUSTRALASIAN ASSOCIATION FOR THE ADVANCEMENT OF SCIENCE.

THE Australasian Association for the Advancement of Science held its fourth annual meeting at Hobart, Tasmania, from January 7 to 14 inclusive. The meeting was in every way successful, and the proceedings afford ample and most satisfactory evidence that much excellent work is being done among our Australasian kinsfolk in every branch of science. The President was His Excellency Sir Robert Hamilton, Governor of Tasmania. The people of Hobart accorded to the members of the Association a most hearty welcome, and did everything in their power to make the occasion a pleasant and memorable one. Visitors from a distance had the advantage of being able to travel both by sea and land at greatly reduced fares, and everything of scientific interest in Tasmania was clearly explained for them in a capital hand-book issued from the Government Printing Office. Mr. Robert Giffen attended the meeting, and was cordially received. He delivered a lecture to the members of the Association on “The Rise and Growth of the British Empire.”

Great credit is due to the Hobart *Mercury* and other local papers for the enterprise they displayed in reporting the proceedings.

At the meeting of the general Council on January 7, the chair was taken by Baron von Mueller, past President, as Sir James Hector, the retiring President, was prevented by ill health from being present. It was formally decided that the fifth annual meeting of the Association should be held at Adelaide, and practically decided that the sixth should be held at Brisbane. Prof. Tate will be President of the Adelaide meeting.



On the evening of the 7th Sir Robert Hamilton delivered his presidential address before a large audience in the Town Hall. He presented an interesting sketch of the history of the Royal Society of Tasmania, and suggested many sound reasons why all intelligent persons in Australasia should do their utmost "to hasten the advent of the time, which is undoubtedly approaching, when science will form a much more integral part of the life of the people than it does at present."

It is impossible for us to give a full account of the proceedings of the meeting; but the following notes may suffice to indicate the wide range of the work done in the various Sections.

## SECTION A.

## MATHEMATICS, PHYSICS, AND MECHANICS.

Prof. Bragg, Adelaide, was President of this Section. He chose as the subject of his presidential address, "Mathematical Analogies between various branches of Physics." About fifty years ago, he said, Sir William Thomson showed that there existed between several branches of physics a very close analogy—the analogy was so exact that the solution of any problem of any one theory was at the same time the solution of the problem in any other. The list of analogies might be still further increased by the addition of certain other theories, which were to some extent imaginary, yet important in that they were simple to realize, and therefore of great use in presenting to the mind the usual means of grasping the other problems. It was a matter of the greatest interest that so wide and so perfect an analogy should exist, and for that reason the analogy would be a fit subject for an address. There were other grounds for its fitness. It was of the greatest assistance in physics to follow up this analogy, and examine carefully its nature. It was a common remark that analogies were dangerous things, and the remark was often true enough. But the danger lay only in an imperfect knowledge of the extent to which calculations might be made upon the analogy, and could be avoided once and for all by amending the imperfection. Moreover, the student of electricity and magnetism could hardly avoid the use of some sort of analogy, for these theories deal with quantitative relations between things of the real nature of which we are completely ignorant, and most minds could not for long consider these relations in mere symbols, but must finally give them some sort of form. He then explained the nature of the problem, and proceeded to show the measure of analogy that exists between various theories of physical science.

A paper by Sir Robert Ball, on "The Astronomical Explanation of a Glacial Period," was read by Sir R. Hamilton, and a hearty vote of thanks was accorded to His Excellency and to the author. Mr. A. B. Biggs, Launceston, read a paper on "Tasmanian Earth Tremors." Mr. C. W. Adams, Dunedin, dealt with a graphic method of showing the relation between the temperature of the dew-point and the temperature of the air for any given climate. Mr. George Hogben, Timaru, N.Z., read the report of the Committee on "Seismological Phenomena in Australasia." This Committee had begun its work by making a compilation of the records of all previous earthquake shocks throughout Australasia, and these records were now nearly complete, except for Queensland and Western Australia. It had also provided for as accurate a system of observations in the future as was possible under the circumstances, by means of memoranda to be forwarded from various telegraph offices. The system adopted was, with the necessary modifications, that which had been in use with success in New Zealand for some time past. The Secretary explained what had been done in New Zealand by this means in the determination of earthquake origins, and of other facts about earthquakes, and pointed out that it was as part of a world system of observations that the observations in Australasia are likely to be most useful. With that aim in view the Committee proposed to extend their observations to the islands of the Pacific, and so to establish a connection, if possible, with what was being done in South America and in Japan. An important step was also taken in the adoption of a common standard of intensity—the Rossi-Forel scale, as used by Swiss and Italian seismologists, being that agreed upon. It was pointed out that the system now adopted throughout Australasia had led to the fixing of five of the chief origins of disturbance in or near New Zealand, among them (during the past year) of the origin of most of the Cook's Straits shocks.

Mr. A. McAuley, Ormond College, Melbourne, contributed a paper on "Quaternions as a Practical Instrument of Physical

Research." He indicated the power of the method by six examples:—(1) A theorem in potentials illustrated by applying it to a general electrical problem. (2) Two examples in curvilinear co-ordinates. (3) A quaternion proof of a well-known theorem of Jacobi's of great utility in physics. (4) A generalization of one of the well-known equations of fluid solution. (5) The well-known particular system of the differential equation expressing the conditions of equilibrium of an isotropic elastic solid subject to arbitrary bodily forces. (6) A short criticism of Prof. Poynting's theory of the transference of energy through an electric field.

Papers were read by Mr. W. H. Steele on "The Conductivity of Solutions of Copper Sulphate"; by Mr. R. W. Chapman on "The Dodging Tide of South Australia," containing a summary of the work done by the Committee on Tidal Observations; and by Archbishop, Murphy, Hobart, on "Solar Phenomena and their Effects."

Mr. H. C. Russell, F.R.S. (Government Astronomer, N.S.W.), read a paper on "The Grouping of Stars in the Southern Part of the Milky Way." He pointed out the advantages of the photographic method of studying star distribution, and discussed the evidence offered by a large number of photographs taken by himself. The results he had obtained tended to diminish the value of the rifts in the discussion of stellar distribution. The interest of this paper was much enhanced by the exhibition of a large collection of photographs.

Mr. R. L. J. Ellery, F.R.S. (Government Astronomer, V.), read a paper describing some of the difficulties occurring in the photographic charting of the heavens, more especially regarding the determination of stellar magnitude. He also spoke of the desirability of establishing tidal observations in Tasmania. He drew attention to the incompleteness of the tidal records for Tasmania, and moved a resolution urging the Government to establish several more tide gauges, especially on the north coast. This resolution was seconded by Mr. H. C. Russell, and carried unanimously.

Mr. R. B. Lucas read a paper on the unification of standards of weights and measures, in which the condition of legislation in regard to this important matter, with suggestions for the unification of standards throughout the colonies, and recommendations for a central depot with central administration, was specially considered.

Captain Shortt (Meteorological Observer, Hobart) read a short paper advocating a particular method of determining longitude at sea from observations of the maximum altitude. The paper gave rise to a very interesting discussion.

The President of the Section moved "That the Section telegraph its congratulations to Sir W. Thomson on his elevation to the peerage." This was seconded by Mr. Ellery, supported by Mr. Russell, and carried unanimously.

## SECTION B.

## CHEMISTRY AND MINERALOGY.

Mr. W. M. Hamlet, Government Analyst, of New South Wales, presided over this Section. In his opening address he dealt with the progress of chemistry in Australasia. Having described the difficulties with which chemists in Australasia have to contend, he said that in spite of them work had been done. He mentioned the discovery of the alkaloids brucine and strychnine in the fruits of *Strychnos pilosperma*, by Prof. Rennie and Mr. Goyder, of Adelaide; also the work done by Mr. J. H. Maiden, of Sydney, in the examination of Australian kinos, gums, and barks. Chief amongst Mr. Maiden's researches was his work on wattle bark, which he found contained from 15 up to 46 per cent. of tannic acid. These barks were proved to be invaluable for tanning purposes, and their cultivation proved easily remunerative to the agriculturist. Mr. Kirkland's discovery of gallium and indium in some specimens of blende were referred to, as were the highly-interesting investigations of different minerals by the Rev. J. Milne Curran, of New South Wales. Reference was also made to researches being made by observers who were seeking to find out the actual state of combination in which elements occur in different ores. Much of this kind of work needed to be done, and if such questions were investigated by men who knew what they were doing, it would go a long way towards facilitating the operations attempted in the smelting works, where it is often expected that carbonates, sulphides, chlorides, and oxides should each and all yield to the same treatment.

The following papers were contributed by Mr. J. B. Kirkland, Assistant Lecturer and Demonstrator of Chemistry, University of Melbourne:—(1) "Notes on the Electrolysis of Fused Salts of Organic Basis"; (2) "Occurrence of the New Elements Gallium and Indium in a Blend of Peelwood, New South Wales"; (3) "Notes on the Volatility of Magnesium"; (4) "Lecture Experiment on Gaseous Diffusion." A paper on "The Analysis of the Cavendish banana (*Musa Cavendishii*) in Relation to its Value as a Food," by W. M. Doherty, was also read. Profs. Liversidge, Jackson, the President, Messrs. Clemes, Wilsmore, and Taylor took part in an interesting discussion that followed the reading of these papers.

Papers were contributed by Mr. W. M. Hamlet on "The Oleo-refractometer in Organic Analysis"; by Mr. A. H. Jackson on "The Analysis of Storage Battery Plates"; by Mr. A. J. Sachs on "The Jarvis Field Mineral Waters of Picton, New South Wales"; and by Mr. Mingaye on "Some Mineral Waters of New South Wales."

Mr. A. Liversidge, F.R.S., Professor of Chemistry, University of Sydney, read a paper on "The Rusting of Iron." It was usually stated in books upon chemistry, he said, that iron rust consisted of the hydrated sesquioxide of iron; but on examining a very large number of specimens of rust from very many different places, and from iron articles of various kinds, and formed under very varied conditions, he found that in almost every instance the rust contained more or less magnetic oxide; in fact, in some cases the rust, although presenting the usual "rust brown" colour and appearance, was, when powdered, practically wholly attracted by the magnet. The specimens which first drew his attention to the subject were some large scales of rust obtained from the rails of an old tramway at Clifden Springs, in Victoria, and he was led to collect and examine these on account of their resemblance to the crust so often present on metallic meteorites. On crushing this rust in a porcelain mortar and testing it with a magnet, it was found to be practically wholly attracted, the small quantity of iron magnetic oxide present being mechanically inclosed, lifted and removed by the magnetic particles (in consequence of the magnetic particles being joined end to end, parallel to the lines of magnetic force and forming a mesh-work inclosing the non-magnetic matter); but by repeatedly applying the magnet, and especially under water, the magnetic powder was fairly well separated from the non-magnetic powder. Bright iron wire, plates, rods, nails, &c., were artificially rusted in many ways with free access of oxygen, and in almost every instance a large amount of magnetic oxide was formed.

Prof. Liversidge also read a paper on "The Presence of Magnetite in Certain Minerals."

Some notes on the analysis of water from Lake Corangamite were given by Mr. A. W. Craig and Mr. N. T. M. Wilsmore. Notes on a "Natural Bone Ash," from Narracoorte, South Australia, were given by Mr. N. T. M. Wilsmore (Melbourne University). This was an account of a fossil guano which might be successfully used for making cupels for silver assays, &c. Other papers read were "Minerals of East Gippsland," by Mr. Donald Clark; and "Notes on the Exudations yielded by some Australian species of *Pittosporum*," by Mr. J. Marden. A Committee was appointed to make a complete census of the minerals of Tasmania for the next meeting of the Association.

## SECTION C.

### GEOLOGY AND PALEONTOLOGY.

Prof. T. W. E. David, of Sydney University, President of this Section, delivered an address on volcanic action in Eastern Australia and Tasmania, with special reference to the relation of volcanic activity to oscillations of the earth's crust, and to heavy sedimentation. The evidences of volcanic action in past geological time in East Australia and in Tasmania were reviewed historically, commencing with the oldest known lavas—the Snowy River porphyries—and concluding with the most recent—those of Tower Hill, near Warrambol, in Victoria. The geological age of the former has been established as being lower Devonian, whereas the occurrence of the skeleton of a dingo under beds of volcanic tuff at the latter locality shows that those volcanic rocks are of recent geological age. Special reference was made to the vast development of contemporaneous lavas and tuffs in the Upper Palæozoic coal-fields of New South Wales, at Raymond Terrace, near Maitland, and at Kiama, in the Illawarra coal-field. Proofs were adduced to show that the

lavas and tuffs at the latter locality were erupted prior to the deposition of the Bulli coal-measures, as marine fossil shells of Permo-Carboniferous age have been found in the volcanic tuffs of that series. The great plateau of diabasic greenstone, which occupies so large an area in the south-eastern portion of Tasmania, was considered by the author to be probably of later origin than the Mesozoic coal-measures of Fingal, Jerusalem, &c., and then the Palæozoic coal-measures of the Mersey coal-field. The greenstone forming the upper portion of Mount Wellington was, in the author's opinion, of later origin than the New Town coal-measures near Hobart. He considered the greenstone to be a variety probably of gabbro, which had burst through the marine mudstones and overlying coal-measures in the neighbourhood of Hobart in the shape of broad dykes and vosses, and which had spread over the top of the measures in the form of a thick broad capping. If this view were correct, there would be underneath the tiers of greenstone large areas of coal-measures which might contain workable seams of coal, undamaged by the overlying greenstone. A brief description having been given of the basaltic lavas of Tertiary age in Australia and Tasmania, the relation of the various manifestations of volcanic activity to oscillations of the earth's crust and to heavy sedimentation was next examined. The evidence collected by Australian and Tasmanian geologists showed that volcanic action had taken place most frequently after periods of prolonged subsidence had culminated in a compensating elevation of the land. Instances were cited to prove that in many cases the subsidence which preceded volcanic outbursts was directly due to the local loading of the earth's crust with thick masses of sediment, the weight of which bulged the earth's crust downwards, displacing in the process the lighter granitic magma which is considered to immediately underlie the earth's crust, and bringing the under surface of the crust in proximity to the heavier basic magma. This was suggested as an explanation of the fact that the products of volcanic action from such areas of subsidence were usually basalts rather than rhyolites or obsidians, both of which last are derived from the granitic magma.

Mr. W. J. Clunies Ross read a paper entitled "Remarks on Coral Reefs." Mr. W. J. C. Ross read a paper "On the Discovery of two Specimens of Fossil Lepidodendrons in the Neighbourhood of Bathurst, New South Wales, and the Inferences to be drawn from their Occurrence." One specimen was from the gravel of the Macquarie River, but its source was too uncertain to be of much value. The other specimen, although not actually found by the writer *in situ*, was received by him from the finder, who was able to point out the exact place from which it was obtained. This was about ten miles to the east of Bathurst, in some one of a series of beds of grit and quartzite forming the sides of a short valley, at the head of which there was a succession of three waterfalls over hard bands of quartzite, the uppermost fall being over a massive conglomerate. The grit bands contained abundant casts of Brachiopods, Spirifer, and Rhyconella, and the whole series of beds was coloured on the geological sketch map of the colony as Silurian. The late Mr. Wilkinson, however, classed the beds as Siluro-Devonian; and a very similar series at Rydal on the Western Railway Line was mapped by him as Devonian. Rydal was at least sixteen miles in a straight line from the locality at which the fossil was found. Near Rydal there were beds containing a Lepidodendron considered by Dr. Feistmantel and Mr. Carruthers as *Lepidodendron notium*, and to be of Devonian age. Mr. R. Etheridge, Jun., however, questioned the identification of the species, and seemed to think it was *Lepidodendron australe*, McCoy, which was generally considered to be Lower Carboniferous. It was pointed out that the fossil now found was almost certainly derived from the grit beds containing Devonian Brachiopods, and was probably of that age. If it were taken as Carboniferous, then a rearrangement of the generally received geology of a large part of New South Wales would be necessary. As bearing on the probable Devonian age of the fossil, attention was called to the fact that in the Lower Carboniferous beds of Strand, N.S.W., there were two species of *Lejiodendron*, viz. *L. Veltheimianum* and *L. Volkmanianum*. The fossil in question did not resemble either of these forms, but appeared to be either *L. notium* or *L. australe*, and, whichever it was, it was likely to be older than the Strand beds, and therefore can hardly be younger than Devonian. The specimens in question were exhibited, and the opinion of geologists desired on the questions raised.

Mr. J. H. Harvey discussed "The Application of Photography to Geological Work." He urged the desirability of having a photographer attached to every Geological Survey, and the importance of conducting the photography of the various surveys in a systematic and uniform manner. He submitted a scheme in connection with the same, which, without a great increase in the present expense, would, he considered, vastly increase the value of the survey.

Among the remaining papers were the following: "Sample of Cone-in-cone Structure found at Picton, New South Wales," by Mr. A. J. Sachs; "Notes on the Permo-Carboniferous Volcanic Rocks of New South Wales," by Prof. T. W. E. David; "Notes on the Advantages of a Federal School of Mines for Australasia," by Mr. J. Provis.

## SECTION D.

## BIOLOGY.

Prof. W. Baldwin Spencer, of the Melbourne University dealt in his presidential address with the fresh-water and terrestrial fauna of Tasmania. He described the various species found in Tasmania, and the distribution of these in other parts of Australia, showing that, in such forms as the fresh-water fish, reptiles, and amphibia, those found in Tasmania and some in Victoria were very closely allied. He dealt with the original introduction of the ancestors of the present animals of Australia, and the way in which the descendants of these had become distributed over the various parts, including Tasmania.

Prof. Hutton, of Christchurch, New Zealand, read a paper on "The Origin of the Struthious Birds of Australasia." The struthious birds—that was, the ostriches, emus, cassowaries, and kiwis—were confined to the southern hemisphere, except the African ostrich, which ranged into Arabia, and they were supposed to have originated in the northern hemisphere and migrated southwards. But by this hypothesis there were great difficulties in explaining how the struthious birds reached Australia and New Zealand without being accompanied by placental mammals. Also the struthious birds of New Zealand, including the lately extinct moas, were smaller, and make a nearer approach to the flying birds, from which the struthious birds were descended, than did any of the others, and they should expect to find the least altered forms near the place of origin. The tinamus of Central and South America, although flying birds, resembled the New Zealand struthious birds in several particulars; and as a former connection between New Zealand and South America was shown by the plants, the frogs, and the land shells, it seemed more probable that the struthious birds of Australasia originated in the neighbourhood of New Zealand from flying birds related to the tinamus, and that they spread from thence into Australia and New Guinea, rather than that they should have migrated southwards from Asia. Probably the ostriches of Africa and South America have a different line of descent from the struthious birds of Australasia, and might have originated from swimming birds in the northern hemisphere.

Prof. Spencer read a paper "On the Habits of Ceratodus, the Lung Fish of Queensland." This fish, he stated, lives only in the Burnett and Mary Rivers in Queensland, and belongs to a small group which may be regarded as intermediate between fishes on the one hand and amphibia on the other. The swimming bladder present in ordinary fishes has become modified so that it functions as a lung. In Africa, *Protopterus*, a form closely allied to *Ceratodus*, makes for itself a cocoon of mud, in which during the hot, dry season it lives and can breathe by means of its lung. The *Ceratodus*, however, does not appear to do this, and probably never leaves the water. It comes continually to the surface, and passes out and takes in air, making a faint spouting noise. The author suggested that the lung was of the greatest service to the animal, not during the hot, but during the wet season, when the rivers were flooded, and the water thick with the sand brought down from the surrounding country. With regard to its food, *Ceratodus* appeared to be herbivorous, feeding, at all events largely, on vegetable matter, such as the seeds of gum-trees which tumble into the water.

Papers were contributed by Mr. F. M. Bailey, Government Botanist of Queensland, on "Queensland Fungus Blights"; by Colonel W. V. Legge on "The Geographical Distribution of Australian Limicolae"; by Mr. John Shirley on "A Re-arrangement of the Queensland Lichens"; and by Mr. A. F. Robin on "The Preservation of Native Plants and Animals."

Mr. W. A. Weymouth contributed a classified list of Tasmanian mosses, based on Hooker's "Flora of Tasmania" (1853-59), Mitten's "Australian Mosses" (1882), Bastow's "Mosses of Tasmania" (1886), and his own collections (1887-91), as determined by European specialists.

## SECTION E.

## GEOGRAPHY.

Captain Pasco, R.N., President of the Section, referred in his opening address to early discoveries in Australia. The exploration of the island of Tasmania, and the opening up of its varied resources, were begun by Sir John Franklin. He might be recognized as the founder of the Royal Society of Tasmania, and distinguished himself in 1842 by crossing the island from New Norfolk to Macquarie Harbour. Half a century ago Australia was considered to be a vast desert, containing possibly an inland sea, but Stuart, McDowall, Gregory, Forest, Giles, and others had dissipated that idea by exploring the continent from one side to the other. He further dealt with the tides and currents of the ocean, and their effects generally upon the earth, the temperature and saltness of sea-water, and the direction and force of the currents and times of high and low water. He concluded by saying there was still a considerable area of this globe to be subdued and peaceable dominion obtained within the Antarctic Circle. Though Sir James Ross unfurled the British banner on an island contiguous to the continent or extensive archipelago (as the case might be), yet almost a blank upon the map awaited the enterprise of the Anglo-Saxons located in the southern hemisphere to emulate their forefathers in the north by opening up the frozen zone.

Mr. James M. Clymont, Koonya, Tasmania, read a paper on "The Influence of Spanish and Portuguese Discoveries during the First Twenty Years of the Sixteenth Century on the Theory of an Antipodal Southern Continent." Mr. D. Murray gave an account of Mr. Lindsay's expedition in Western Australia under the auspices of Sir Thos. Elder, giving extracts from his despatches, narrating the journey from Fort Mueller to Queen Victoria Springs, and thence to the Frazer Ranges. Want of water had been a great and unexpected difficulty. There seemed to have been a complete drought for at least a year over this part of the continent. In the discussion ensuing, the question of artesian wells was raised, and Mr. Murray explained that while some of these wells in South Australia were unfit for irrigation purposes, owing to the superabundance of salts of soda, yet they were good enough for stock, &c., and that both further north and further east over large areas the wells gave water suitable for all purposes.

Papers were contributed by Dr. Frazer, on "Volcanic Phenomena in Samoa in 1886"; by the Rev. J. B. W. Woolnough, on "Iceland and the Icelander"; by Captain Moore, R.N., on "A Magnetic Shoal near Cossack, W. A."; and by Mr. A. C. Macdonald, on "The Life and Works of Sir John Franklin."

An elaborate and valuable paper on "Recent Explorations and Discoveries in British New Guinea," was read by Mr. J. P. Thomson. Referring to the natives, Mr. Thomson spoke of their numerous tribal divisions, and of the almost correspondingly different languages or dialects spoken by them. Even in localities separated by only a few miles, the dialects spoken differ the one from the other in some cases considerably. The Motu, which is the language spoken and taught by the missionaries at Port Moresby, is understood over a considerable area, both east and west of that place, but outside that neighbourhood changes and variations occur, so that at the head of the Great Papuan Gulf, and in the Fly Basin, the Motu language is a foreign tongue. The same applies to the eastern end, and to the islands adjacent thereto, where the philological variations are numerous and conflicting. While in the one case the people met with in the highland zones of the Owen Stanley Range spoke a dialect akin to that of the Papuan, those encountered on the Upper Fly River expressed themselves in a tongue, every word of which apparently differed from that spoken by the tribes of the lower regions, and from that spoken by any known coastal community, notwithstanding that the people themselves exhibited no evidence of possessing distinctive characteristics of race, the only marked contrast being in lightness of colour. In the western division the same diversity of speech is met with, where neighbouring tribes are unable to hold intercourse one with the other, even if friendly, by reason of incompatibility of language. No doubt this may in some measure be accounted

for by local environment; constant civil intertribal war being the means of isolating communities, so that no friendly intercourse is held, by reason of which, together with other attendant causes, an incongruity of language may have unknowingly been established. With reference to geology, Mr. Thomson said it was somewhat remarkable that the general geological features of British Papua are in a very considerable degree identical in character with those of Australia, several specimens being coincident with those of the Silurian series from gold-fields in New South Wales, while some of the fossiliferous rocks were obtained from beds of clay similar to those at Geelong and Cape Otway in Victoria. Mineral areas of great value might yet await discovery by the penetrating eyes of British pluck and enterprise in Papua.

## SECTION F.

## ECONOMICS AND SOCIAL SCIENCE AND STATISTICS.

Mr. R. Teece, President, chose for the subject of his opening address, "The New Theory of the Relation of Profit and Wages." Papers were contributed by Mr. Alfred de Lissa, Sydney, on "The Organization of Industry"; by the Hon. N. J. Brown, Tasmania, on "The Incidence of Taxation"; by Mr. H. H. Hayter, Government Statistician, Victoria, on "Disturbance of Population Estimates by Defective Records"; by Mr. A. J. Ogilvy, on "Is Capital the Result of Abstinence?"; by Mrs. A. Morton, Tasmania, on "The Past Attitude of Capital towards Labour, and the Present Attitude of Labour towards Capital"; by Mr. T. A. Coghlan, Government Statistician, N.S.W., on "The Wealth of Australasia"; by Mr. A. J. Taylor, Hobart, on "The Value of Labour in relation to the Production of Wealth regarded from the Standpoint of a Physicist"; and by Mr. E. P. Nesbit, South Australia, on "Insanity and Crime."

## SECTION G.

## ANTHROPOLOGY.

The Rev. Lorimer Fison, President, said in the course of his opening address that in anthropological study the two main things required were first a patient continuance in collecting facts, and second the faculty of seeing in them what is seen by the natives themselves. But the natural tendency to form a theory as soon as a fact was seized, and looking at facts in savagery from the mental standpoint of civilized man, would lead investigators into fatal mistakes. The best way to gain information was to live with the natives, learn their language, and gain their confidence, or get information from the men living amongst them. References to aborigines, their manners and customs, in books, might be collected and classified by many readers, and thus facilitate investigation. In conclusion he dwelt upon the magnificent and all but untrodden field afforded by British New Guinea and its outlying groups of islands; and two extremely valuable books—the Rev. Dr. Codrington's on "The Melanesian Tribes," and "The Maori Polynesian Comparative Dictionary," by Mr. Edward Tregear, of New Zealand—were recommended for study.

The Rev. Dr. Gill, who has spent thirty-three years as a missionary in the Hervey Islands, read papers on "The Story of Tie and Rie" and "The Omens of Pregnancy," the latter having reference to superstitions still current in the island of Mangaia.

A paper on "New Britain and its People" was read by the Rev. B. Danks. According to the author, the bush people differ very much from the coast tribes, the latter being evidently invaders and conquerors.

Some interesting details as to "Sydney Natives Fifty Years ago," were given by the Rev. W. B. Clarke. Among other papers were the following: "Group Marriage and Relationship" and "The Nair Polyandry and the Dieri-Dieri Pirauru," by the Rev. L. Fison; "The Samoa and Loyalty Islands," by the Rev. S. Ella; "The Cave Paintings of Australia," by the Rev. J. Matthew; "The New Hebrides," by the Rev. D. Macdonald; "The Origin of the Sense of Duty," by Mr. Alex. Sutherland; "Notes on the Taunese," by the Rev. W. Gray.

## SECTION H.

## SANITARY SCIENCE AND HYGIENE.

Prof. W. H. Warren, of the University of Sydney, gave in his residential address a sketch of sanitary engineering from its earliest days, and then proceeded to discuss the various schemes

which have been proposed for disposing of the sewerage of towns.

Dr. James read a paper on "Cremation as a Step in Sanitary Reform." Papers were also contributed by Dr. E. O. Giblin, on "The Etiology of Typhoid"; by Miss Violet Mackenzie, on "Physical Education and Exercise in Schools"; by Dr. Barnard, on "Infection in Disease"; and by Dr. A. Moulton, on "Sewerage of a Seaside City."

## SECTION I.

## LITERATURE AND FINE ARTS.

This Section, although it assembled for the last time at the Hobart meeting, proved to be very popular. The President, Prof. Morris, of the University of Melbourne, referred in his opening address to the subject of Universities in Australia. He urged that it was not wise to multiply Universities. "In this matter," he said, "the law of supply and demand cannot be trusted, if it ever can be in the matter of education; and the Legislatures should be very careful not to permit the promiscuous conferring of degrees. Let them increase teaching facilities as much as generosity may make possible; do not lower the standard, as at least in the higher education competition does. In America there are five or six degree-giving Universities to every million inhabitants, and a degree by itself has no value. If Australia were one country, as it ought to be, two Universities would probably be quite enough, or, better still, even one, but it would need to be arranged somewhat on the pattern of the University of New Zealand, with teaching bodies in different places, but one uniform standard of examination for each degree. This would lead to emulation between the different teaching Colleges, and would surely have happy results. Unfortunately Australia is not one, and at present it looks as if, in spite of the wishes of the people, our absurd divisions were likely to continue. Yet it is worth consideration whether the Universities might not agree upon a common standard, and arrange that the courses in the Universities of the different colonies should be parallel and homogeneous. Educated men should be the first to show that the day of discord is over, and to welcome the arrival of unity and co-operation."

Among the contributions to the proceedings of this Section were papers on "Elementary Science in Primary Schools," by Mr. James Rule, senior inspector of schools, Tasmania; "Secondary Education in Australia," by Mr. Percy A. Robin; and "The Rationale of Examinations," by Mr. F. J. Young. A Committee was formed to establish a Home Reading Union for Australia.

## SECTION J.

## ENGINEERING AND ARCHITECTURE.

Mr. C. Napier Bell, President, referred in his opening address to sanitary engineering. In Australia, he said, the best attention of engineers should be devoted to sanitary engineering; first, to cleanse the towns, and second, to save the sewage to irrigate the land. On this subject Australian engineers should pause before copying the practice of Europe, which, enjoying an abundant rainfall, has never felt the same necessity for irrigation, and has had abundant stores of fossil manure to draw upon. Water irrigation was even more important, and he foresaw for engineers a noble task in providing irrigation for Australia. After dealing with the irrigation works of the older countries, he touched upon the importance of mining and electrical engineering. Then he remarked the neglect of warming and ventilation by architects and engineers, and argued that in the climate of Australia the art of cooling must certainly become as important as that of heating. In conclusion, he explained the necessity for sound theoretical and scientific knowledge in the engineer, and said that if the people of the colonies would entertain the honourable ambition, once more popular than now, of being remembered to the distant ages of the future, they must emulate those mighty peoples of the past who left imperishable records of their life in the ruins of their vast public works.

Among the papers read in this Section was one by Mr. Edward Dobson, on "The Evidence for the Prevalence of Human Habitations in Prehistoric Times." It was devoted to showing that, whilst rectangular forms prevailed in the early buildings of the East and in North America, the circular form had prevailed through Africa (with the exception of the Nile Valley) and through Switzerland and Northern Europe, in

Lapland and Greenland, and inquiry was raised as to the causes of these facts.

Mr. A. North read a paper on "The Truthful Treatment of Brickwork."

At the closing meeting of the Council, on February 14, the following general officers were appointed:—Treasurer, Mr. H. C. Russell, Sydney; Secretary for Tasmania, Mr. A. Morton; for New Zealand, Prof. Packer, Prof. Thomas, and Mr. D. B. Brandon; for Victoria, Mr. A. H. S. Lucas; for Queensland, Mr. J. Shirley.

### THE DRAPER CATALOGUE OF STELLAR SPECTRA.

THE Observatory of Harvard College has played a prominent part in the development of astronomical photography. It was here, on July 17, 1850, that Prof. Bond obtained the first photographic image of a star, and from that time forward much important work has been accomplished, culminating in the Draper Catalogue of the photographic spectra of 10,347 stars. The progress of this latter branch of astronomical work has been but slow, and it is a remarkable fact that its extraordinary development during the last few years has followed from the revival by Prof. Pickering of the method of observation first employed by Fraunhofer in 1824. Accounts of the progress of the work have been published from time to time, and have been noticed in our columns. A complete account of the "Preparation and Discussion of the Draper Catalogue," which has recently been issued, forms vol. xxvi., part 1, of the *Annals of the Astronomical Observatory of Harvard College*.

The earlier attempts to photograph the spectra of the stars were made with spectroscopes having slits, although, from the time of Fraunhofer, it was recognized that a slit was not an essential part of a stellar spectroscope. In 1863, Dr. Huggins succeeded in photographing the spectrum of Sirius, but none of the characteristic lines were visible. In 1872 Dr. Henry Draper, to whose labours in the field of astronomical photography the Draper Catalogue forms a fitting memorial, succeeded in obtaining a photograph showing four lines in the spectrum of Vega. Dr. Huggins again took up the work, and since 1879 has obtained a considerable number of photographs, none of which, however, appear to show anything approaching the amount of detail now obtainable. In all these attempts the spectroscope was attached to the eye end of the telescope, so that the image of the star was formed on the slit, a cylindrical lens being interposed in order to give width to the spectrum.

In the method which has been so pre-eminently successful, the slit and collimator, which form an essential part of an ordinary spectroscope, are dispensed with, the rays from a star already possessing the necessary parallelism and its image being almost a perfect slit without length. It is only necessary, therefore, to fix a prism in front of the objective of a telescope, and to introduce some means of widening the spectrum, to obtain a complete stellar spectroscope. For eye observations the necessary width is obtained by the use of a cylindrical lens in conjunction with the eye-piece of the telescope. For photographic work, the prisms are so arranged that the spectrum lies along a meridian, and it is then only necessary to allow the driving clock to be slightly in error to obtain a widened spectrum. The clock error must of course vary according to the magnitude and declination of the star.

The great advantage of the "slitless spectroscope" depends upon the fact that every scrap of light passing through the object-glass is utilized; with the ordinary spectroscope it will seldom happen that all the light passes through the slit, and it is further reduced by absorption in the lenses and prisms of the spectroscope. Further, on account of the large focal length of the telescopes employed, a high dispersion is obtained even with a prism of small angle; and a large number of spectra can be photographed at a single exposure. Prof. Pickering has photographed the spectra of as many as 260 stars on the same plate, and the labour involved in the construction of the Draper Catalogue has thus been enormously reduced. Indeed, the whole of the 10,347 spectra were photographed on 585 plates. The improvement in photographic processes has undoubtedly done much to facilitate the work, but it is lamentable that the "wholesale" method was not applied twenty years ago, for even with the less perfect processes then in vogue, our knowledge would have been much advanced.

An important feature of Prof. Pickering's work is the method of enlargement of the negatives, which renders the fainter lines clearly visible. "The negative is covered by a diaphragm, having a slit in it which is made to coincide with the spectrum. An image is then formed by an enlarging lens in the usual way. A cylindrical lens is next interposed near the enlarging lens, with its axis perpendicular to the lines in the spectrum. The width of the latter may thus be increased indefinitely without changing the length. In the case of faint stars very narrow spectra only can be obtained. Their energy is so feeble that they are capable of decomposing the silver particles only if allowed to fall upon them for a long time. In the enlargement the energy of the sun is substituted for that of the star, and thus an indefinite number of silver particles may be decomposed." (Introduction, p. xix.) The original negative may, perhaps, be compared to a "relay" in electrical apparatus.

The preparation of the Draper Catalogue involved five different steps, which are thus stated on p. 74:—

I. Measurement of the spectra on each plate, including the determination of their positions, intensities, and the classes to which they belong.

II. Identification of each spectrum with that of a star in the Durchmusterung or other catalogue.

III. Reduction of the measures of brightness to the scale of the Harvard Photometry.

IV. Catalogues of plates.

V. Preparation of the final catalogue, bringing forward the places of all the stars to 1900, including various methods of checking and correcting the results.

That a catalogue of spectra may be of service to astronomers, a sound system of classification is essential, and this, as far as possible, should have some reference to chemical or physical constitution. The notable classifications which were suggested by eye observations were those of Secchi, Vogel, and Lockyer, but it is not surprising to find that the greater detail shown on the photographic plates requires modifications of these in order that all the spectra may be included. A detailed but somewhat arbitrary classification has been adopted by Prof. Pickering, the chief merit of which is that it readily lends itself to translation into other systems. Varieties of Secchi's first type are indicated by the letters A, B, C, D, those of the second type by the letters E to L, of the third type by M, and of the fourth type by N; bright line stars are referred to as O, planetary, nebulae as P, and other spectra as Q. Of the varieties of the first type, A includes all the stars with spectra similar to Sirius, and B those with spectra of the Rigel type, in which, in addition to lines of hydrogen, there is a small number of strong lines of which the origins are at present unknown.

Results of special interest, such as the discovery of bright lines in the spectra of variable stars of long period, have already been referred to in NATURE, and we shall now confine ourselves to the more general results. As some of the most interesting spectra belong to stars of small magnitude, it is necessary to be very guarded in making generalizations. Still, the fact that Prof. Pickering's researches have extended in some cases to stars of the ninth and tenth magnitude perhaps justifies the assumption that all types of spectra are now included. We cannot do better than let Prof. Pickering speak for himself.

"The general conclusion derived from the study of these spectra, is the marked similarity in constitution of the different stars. A large part of them—those of the first type—have a spectrum which at first sight seems to be continuous, except that it is traversed by broad dark bands due to hydrogen. Closer inspection shows that the K line is also present as a fine dark line. If the dispersion is large and the definition good, many more dark lines are visible, as stated above. These lines may be divided into two classes—first, those which predominate in many stars in the Milky Way, especially in the constellation of Orion; and, second, those present in the solar spectrum. Nearly all the brighter stars may be arranged in a series, beginning with those in Orion, in which the auxiliary lines are nearly as intense as those due to hydrogen. Other stars may be found, in which these lines successively become fainter and fainter, until they have nearly disappeared. The more marked solar lines then appear, become stronger and stronger, and the hydrogen lines fainter, until they gradually merge into a spectrum identical with that of the sun. At least, several hundred lines appear to be identical, and no differences can be detected. Continuing the sequence, the spectra pass gradually into those of the third type. Certain bands become more

marked, and the spectra of the third type may be divided into four classes. In the fourth of these classes the hydrogen lines are bright instead of dark. This spectrum seems to be characteristic of the variable stars of long period when near their maximum. As stated above, it has led to the detection of several new variable stars, and has been confirmed in many of the known variables. Slight peculiarities are noticed in the spectra of many stars, so that they cannot be arranged in an exact sequence; but these deviations are not sufficient to affect the general law. The number of stars not included in the above classification is very small. A few stars like  $\gamma$  Cassiopeiz,  $\beta$  Lyræ, and  $\delta$  Centauri resemble the stars of the Orion type, but some of the lines are bright instead of dark. Stars of the fourth type, whose spectra appear to be identical with that of carbon, are not included in the above classification. Other stars, whose spectra consist mainly of bright lines, like those of the planetary nebulae, may be included with them in a fifth class. It also appears that the position of the lines in both cases is probably identical with that of corresponding lines in stars of the Orion type." (Introduction, p. xvii.)

It would be difficult to find fault with the masterly way in which Prof. Pickering and his assistants have done their work. Our chief source of complaint, which no doubt arises more from impatience than anything else, is the lack of detail with regard to the spectra themselves. For investigations to which such a work as the Draper Catalogue should naturally lead, a mere estimation of the type of spectrum serves for little more than a determination of the relative numbers and distribution of the spectra of the various types. For the present, however, this is practically all that Prof. Pickering tells us. We are left quite in the dark, for instance, as to what is actually seen in the photographs of the spectra of stars of Secchi's fourth type, although we are informed that the photographic spectra are as characteristic as the visual. It would be interesting too, to know the differences in the sub-divisions of Secchi's third type.

All stars north of  $-20^\circ$  of the fourth magnitude and brighter have been photographed on a large scale with the 11-inch refractor, and a discussion of these will occupy a subsequent volume of the "Annals." This will be awaited with interest by all who are engaged in researches in astronomical physics.

We are delighted to find that the work of the Henry Draper Memorial is to be extended beyond the mere routine of photographing stellar spectra. "A broader field has been assigned to the Henry Draper Memorial by Mrs. Draper than was at first proposed. Instead of confining its work to the study of the spectra of the stars, their physical properties in general will be investigated. The liberal support given to it should give yet more striking results in the future than have hitherto been attained." (Introduction, p. xxiv.)

Laboratory work has already been commenced, and to aid the study of spectra in the electric arc, a 10-h.p. dynamo has been generously presented by the Edison Electric Co.

In the final chapter the Draper Catalogue is discussed with reference to the visual observations of Vogel and Konkoly. A similar comparison has already been given in NATURE, vol. xlv. p. 133, by Mr. Espin, and we need not further refer to it. We regret to find, however, that a discussion of the photographic spectra in relation to the new classification suggested by Mr. Lockyer has not been included.

It will be a source of gratification to Mr. Lockyer to find that his suggestion that stars of the Wolf-Rayet type are the first results of nebulous condensations is fully confirmed by Prof. Pickering's work. Their spectra greatly resemble those of the planetary nebulae, the chief difference being that the characteristic nebula line near wave-length 500 is absent. This, Mr. Lockyer explains, is due to increased temperature, and this view is strengthened by the fact that the line was seen only during the later stages of the visibility of Nova Cygni. Nebulae and bright line stars form Group I. of his classification.

So far, this is the chief point where the Draper Catalogue throws any additional light on Mr. Lockyer's views, and further discussion must be reserved until more details of the spectra are published.

The "distribution of spectra" forms the subject of chapter vii., and we gather that the stars down to magnitude 6.25 are distributed as follows among the different classes of spectra:—

Class A ...	0.61	Class K ...	0.18
" B ...	0.02	" M ...	0.013
" F ...	0.12	" Peculiar ...	0.007
" G ...	0.05		

"According to Secchi's classification, placing Classes A, B, and F in the first type, G and K in the second, and M in the third, we have of the first type 0.75, of the second 0.23, of the third 0.01, peculiar 0.01" (p. 151).

To study the distribution in space, the sky was divided into 48 zones, and the results are thus summarised on p. 152. "It appears that the number of stars of the second and third type is nearly the same in the Milky Way as in other parts of the sky. Considering, therefore, only the stars whose spectra resemble that of our sun, we should find them nearly equally distributed in the sky. The stars of Class A, on the other hand, are twice as numerous in Region M (through which the Milky Way passes) as in Region N (an equal area away from the Milky Way), and in the case of Class B this ratio exceeds four. The Milky Way is therefore due to an aggregation of stars of the first type, a class to which our sun seems to bear no resemblance as regards its spectrum. Spectra of Class B seem to conform still more closely to the region of the Milky Way, although probably they are not sufficiently numerous to materially affect its light. The Milky Way must therefore be described as a distinct cluster of stars to which, from its composition or age, the sun does not seem to belong."

The statement that the sun bears no resemblance to stars like those which chiefly constitute the Milky Way is not quite so precise as it might be. The lines in the spectra, so far as we know them, indicate the same substances in each, and the tendency of evidence is to show that the sun is a type of what the stars of the Milky Way will become.

Not the least interesting part of the researches connected with the formation of the Draper Catalogue is that dealing with the determination of photographic magnitudes. Elaborate investigations have been carried out by Prof. Pickering with his usual skill and care, and we hope to refer to them in some detail on another occasion.

No satisfactory method of applying the slitless spectroscope to the determination of velocities in the line of sight, except in the special case of a spectroscopic binary, has yet been devised, and this branch of research must therefore be carried out in the usual way. A. FOWLER.

#### UNIVERSITY AND EDUCATIONAL INTELLIGENCE.

OXFORD.—We regret to notice that the Savilian Professor of Geometry (J. J. Sylvester, Hon. D.C.L.), has had to apply for leave of absence and dispensation from the performance of statutory duties on account of ill-health. Mr. J. Griffiths, Fellow and Tutor of Jesus College, will lecture on the "Recent Geometry of the Circle and Triangle" for the Professor.

At a meeting of the Hebdomadal Council, Rev. W. Inge, Provost of Worcester College, and Rev. W. W. Jackson, Rector of Exeter College, were elected to be members of the Delegacy for the Training of Teachers under the provisions of the Statute approved by Convocation, November 24, 1891; and in a Congregation holden February 23, Joseph Wells, Fellow of Wadham College, and George R. Scott, Fellow of Merton College, were likewise elected members of the same Delegacy.

In a Convocation holden on March 1, Mr. Henry Balfour, Trinity College, was appointed Curator of the Pitt-Rivers Museum, to hold office until December 31, 1898, and during that period to enjoy the same status in regard to the University Museum as the Professors teaching in the Museum, and to receive a stipend of £200 a year from January 1, 1892. The Curators of the University Chest were authorized to expend a sum not exceeding £150 a year from January 1, 1892, for seven years, on assistance and current expenses in the Pitt-Rivers Museum.

CAMBRIDGE.—Mrs. Philipps offers to the University a sum of £2000 to found an "Arnold Gerstenberg Scholarship" in memory of her brother. The Scholarship is to be held by men or women who have passed the examination for the Natural Sciences Tripos and intend to pursue the study of mental and moral philosophy.

A grant of £40 has been made to H. Kynaston, B.A. of King's, from the Worts Fund, to enable him to investigate the geology of the Eastern Alps in the ensuing summer.

Prof. Foster is appointed an Elector to the Downing Professorship of Medicine, to the Professorship of Zoology, and to

the Professorship of Botany; Prof. Dewar an Elector to the Professorship of Chemistry; Prof. Liveing an Elector to the Jacksonian Professorship; Prof. G. H. Darwin an Elector to the Cavendish Professorship of Physics; Prof. Sir G. G. Stokes an Elector to the Professorship of Mineralogy; Dr. J. Hopkinson an Elector to the Professorship of Mechanism and Applied Mechanics; Prof. Ray Lankester an Elector to the Professorship of Zoology; Mr. W. H. Huddleston to the Woodwardian Professorship of Geology; and Dr. Gaskell an Elector to the Professorship of Physiology.

At the Congregation on February 25, graces for the establishment of two lectureships in Agricultural Science, one of which should be held by a Director of Agricultural Studies, were rejected by 103 votes to 91. A grace for the appointment of a Syndicate to consider the question of degrees in science was rejected by 154 votes to 105. The latter was opposed by a number of the teachers in natural science, as tending to place their students in a position of isolation, and perhaps of inferiority, as compared with others.

The Rev. W. M. Campion, D.D., Fourth Wrangler in the Mathematical Tripos of 1849, and formerly an Examiner for the Mathematical and Moral Sciences Tripos, was on February 23 unanimously elected President of Queen's College, in succession to the late Dr. G. Phillips.

SOCIETIES AND ACADEMIES.

LONDON.

Royal Society, February 25.—“Note on the New Star in Auriga.” By J. Norman Lockyer, F.R.S.

Since my note of February 11, observations of the new star have only been possible at Kensington on seven evenings—namely, February 11, 12, 13, 16, 22, 23, and 24. The 13th and 22nd were the only two very fine nights.

The star now appears to be fading. In the photograph of the region taken on February 3, the Nova appeared to be brighter than  $\chi$  Aurigæ (magnitude 5.0), but in that taken on February 23 it is not brighter than the companion to this star, which is fainter than sixth magnitude. No marked diminution in brightness was noticed before February 22.

The colour has not appreciably changed since the star was first observed.

Photographs of the spectrum were attempted on all the dates named. Those of February 11, 12, 16, and 23, however, were insufficiently exposed, but they show that the dark lines were still more refrangible than the accompanying bright ones, and that the same lines were present as in the previous photographs. A plate was exposed for 2 hours 35 minutes on February 24, but no impression was obtained. The photograph taken on February 13 is identical with those referred to in the notes which I have already communicated to the Society. In the three photographs of February 22, there appears to be a slight diminution in the intensity of the H and K lines, but otherwise there is no decided change.

There is no evidence of revolution during the twenty days of observation. In all the photographs the dark lines are more refrangible than the bright ones, and the relative velocity deduced from those of February 3, 7, 13, and 22 appears to be about 600 miles per second. As this only represents the velocity in the line of sight, we are still ignorant of the real velocities of the two bodies. The constant relative velocity indicated by the displacement of the bright and dark lines may be regarded as confirming the supposition that two meteor-swarms or comets have collided, the velocities being so great, and the masses so small, that neither was captured by the other.

The relative velocity of 600 miles per second seems at first sight to be abnormally great, but if we regard each of the component swarms as moving at the rate of 300 miles per second, the velocities are quite comparable with those of other bodies in space. The star 1830 Groombridge, for example, moves at the rate of 200 miles per second across the line of sight, and its real velocity may be much greater.

Eye observations have been made on every available occasion. The chief variation from those previously reported is the general fading of the continuous spectrum, and the consequent unmasking of the lines between *b* and *D*. Micrometric measures of four new lines in this region were made by Mr. Fowler on February 23 and 24. These, with the other lines observed at Kensington in the region F to C, are shown in the table which follows. The corresponding lines observed in the spectra of new stars which have previously appeared, and those in the spectra of some of the bright-line stars, are added for comparison.

Nova Aurigæ.		Nova Cygni.			Nova Andromedæ.	Nova Coronæ.	$\gamma$ Argûs.	Arg.-Oeltz. 17681.	Lalande 13412.	1st Cygnus.	2nd Cygnus.	3rd Cygnus.	$\gamma$ Cassiopeiæ (Sherman).	Suggested origins.
Feb. 23.	Feb. 24.	Cornu.	Vogel.	Cope-land.										
656 (C)	656	661	656	656	—	656	—	—	—	—	—	—	—	H (656.2)
635	630	635	630	630	—	—	—	—	—	—	636	636	635	—
589 (D)	—	588	589	589	—	—	590	—	—	—	—	—	—	Na (589.1)
579	579	—	580	577.5	—	—	580.9	581	581	583	581	581	—	Fe (579.0)
—	570	—	—	—	—	—	—	—	—	571	570	—	—	—
566	—	563	564	—	—	—	566	—	—	—	—	564	—	C (563.5)
558	558.3	—	—	—	558	—	—	—	—	558	—	558	556	Mn (557.6)
531	531.5	531	531	—	532	—	—	—	—	—	—	—	531	—
518	517.7	518	—	—	517	—	—	—	—	—	—	517	517	{ C (516.5) or Mg (517.5) Mg (500.6)
500.6	500.6	500	499	502	—	501	—	—	—	—	—	—	499	—
490	490.3	—	490	—	—	—	—	—	—	—	—	—	—	—
486	486.2	483	486	486	486	486	—	—	—	—	—	—	486	H (486.2)

It will be seen that all the lines of Nova Aurigæ have previously been recorded in other Novæ, or in the bright-line stars.

The complete spectrum, including the photographic region, is shown in a diagram (which was exhibited). This, and the light curve of the spectrum from F to C, were drawn by Mr. Fowler and Mr. W. J. Lockyer on February 22, and confirmed by Mr. Fowler on February 23. The 3-foot reflector and McClean spectroscope were employed in each case.

The changes which are taking place in the Nova are exactly what would be expected according to my hypothesis that new stars are produced by the collisions of meteor-swarms. The

rapid fading of the star demonstrates that small bodies and not large ones are engaged, and this is further confirmed by the observed diminution in the brightness of the continuous spectrum relatively to the bright lines. If two condensed bodies were in collision, it is evident that the lines would fade first.

Chemical Society, February 4.—Prof. A. Crum Brown, F.R.S., President, in the chair.—The following papers were read:—Peditic motion in relation to colloidal solutions, by W. Ramsay. The peditic or Brownian motion of small particles depends (1) on the size of the particles, (2) on their density, and (3) on the nature of the medium in which they are sus-

pended. If an electrolyte be added to a liquid containing such particles in a state of pedetic motion, the movement is soon arrested, owing to the particles touching one another, and cohering to form clots or clusters. If no electrolyte be present, the particles do not tend to touch each other. From microscopic observations, it is calculated that a particle with a mass of  $2.8 \times 10^{-13}$  grams moves through, approximately, its own diameter,  $1.4 \times 10^{-4}$  c.m., in a second. Such a particle has one hundred billion times the estimated mass of a water molecule; hence, if its pedetic motion be produced by bombardment from water molecules, these must exist in complex groups of considerable mass and some stability. The fact that pedesis is stopped by the addition of an electrolyte would appear to indicate that the water complexes are disintegrated in the presence of ions. The effect of pedetic motion in a liquid is to cause hydrostatic pressure; such hydrostatic pressure would be less on a membrane capable of penetration by the molecular aggregates or particles than on one not so permeable. It is not unlikely that these particles obey gaseous laws in regard to pressure on the sides of the containing vessel, as microscopic observations show that the relative velocity of the particles depends on their mass and density. L. Meyer has pointed out the great discrepancies existing between measurements of the osmotic pressures of solutions and the pressures calculated on the assumption that the dissolved substances obey gaseous laws. These discrepancies may be best explained by considering that combination of the dissolved substance with the membrane walls takes place, and that, subsequently, dissociation of the compound occurs at the other side of the cell wall, as in the case of hydrogen penetrating a palladium diaphragm. The author is disposed to conclude that solution is merely subdivision and admixture, accompanied by pedetic motion, that the true osmotic pressure has never been measured, and that a continuous passage can be traced between visible particles in suspension and matter in solution.—The acid action of drawing-paper of different makes, by W. N. Hartley. An examination of numerous samples of the best drawing-papers shows that they all contain free sulphuric acid. Water in which the paper has been steeped yields a precipitate of barium sulphate, and solutions of helianthin and azolitmin painted on to the paper give the acid reaction.—The interactions occurring in flames: a correspondence between Sir G. G. Stokes and H. E. Armstrong. Sir G. G. Stokes considers that the facility with which steam is decomposed by glowing carbon favours the view that, at a high temperature, oxygen combines with carbon in preference to hydrogen. He considers it necessary to distinguish carefully between the changes which take place in the partial combustion of a molecule and those which are produced in neighbouring molecules as a result of the heat liberated. This latter change may be termed a thermo-chemical one, in contradistinction to a pure chemical change. In the blue base of a candle flame, where oxygen is plentiful, pure chemical change may occur. The blue part envelops for a little way the highly luminous shell in which glowing carbon is present. This carbon may owe its origin to a thermo-chemical change, the heat being derived from the pure chemical change occurring just outside it. The hydrocarbon spectrum may be due to a gas formed by a pure chemical change; this gas is generally supposed to be acetylene, but Sir G. Stokes considers that it is more probably methane. This unknown gas is a hydrocarbon, which, when burnt in the pure state, would show but feebly, if at all, the hydrocarbon spectrum. For, in order that it should show its spectrum, its molecule must be in a state of violent agitation; this might be expected to be the case if it had just been formed as the result of partial decomposition, but would not be so merely because it was going to be destroyed by union with oxygen. Dr. Armstrong, while admitting that the facts do not justify the assertion that oxygen combines with hydrogen in preference to carbon when a hydrocarbon is burnt with insufficient oxygen, is unprepared to adopt the view, advocated by Sir G. Stokes and Prof. Smithells, that the carbon is the more combustible, and thinks that the actual condition of affairs is far less simple than is expressed in the statement of either of these views. There seems to be very little opportunity in flames for simple heat changes to occur, the molecules of different kinds being so mixed up together. Thus opportunity is given for interactions to occur, the end result of which is the same as that of a simple heat change of the chief substance concerned; merely because a change occurring at one moment is reversed the next, and so escapes notice. In this way, con-

tiguous molecules may play the part of surfaces, and that there can be little doubt that such actions are of primary importance may be inferred from the well-known fact that the extent to which the dissociation of water vapour takes place depends on the character of the surface in contact with which it is heated, and not solely on the temperature. In fine, it seems permissible to doubt whether, under the conditions present in flames, carbon is ever separated by simple heat changes. It will certainly be unwise at present to infer that the oxidation of the hydrocarbons, or the separation of carbon and also of hydrogen from them, takes place entirely in any one way.—Properties of alcoholic and other solutions of mercuric and other chlorides, by S. Skinner. The author has determined the variation in the boiling-point of alcohol produced by dissolving it in mercuric, lithium, magnesium, and calcium chlorides, as well as the variation in the boiling-point of a solution of hydrogen chloride of constant boiling-point produced by mercuric chloride. He has also studied the distribution of mercuric chloride between the two solvents, water and ether. The results indicate that mercuric chloride affords a case in which the measure of the property is a simple function of the quantity of salt present, whereas in the case of the other chlorides, the measure of the property involves some higher power.—The isomeric  $\alpha$ -bromocinnamic acids, by S. Ruhemann. An account is given of experiments on the action of ammonia and phenylhydrazine on the  $\alpha$ -bromocinnamic acids.

Entomological Society, February 10.—Mr. Frederick DuCane Godman, F.R.S., President, in the chair.—The President nominated Lord Walsingham, F.R.S., Captain Henry John Elwes, and Dr. D. Sharp, F.R.S., Vice-Presidents for the session 1892-93.—Mr. E. Meyrick exhibited a number of specimens of *Euproctis subiceps*, Walk., taken by Mr. Barnard, showing the extraordinary variation of this Tasmanian species, all the males of which had been "sembled" by one female. The males were represented by various forms ranging from black to white, which had all been described as distinct species. Dr. Sharp, Mr. Hampson, Mr. McLachlan, Colonel Swinhoe, Mr. Elwes, Mr. Poulton, and Mr. Jacoby took part in the discussion which ensued.—Dr. Sharp exhibited samples of pins which he had tried for preventing verdigris, and stated that silver wire was the best material to use, as insects on silver pins remained intact, whilst those on gilt pins were destroyed by verdigris.—Mr. G. T. Porritt exhibited a series of specimens representing Huddersfield forms of *Polia chi*, including nearly melanic specimens, found there during the last two seasons. He said these forms had not hitherto been observed elsewhere.—Mr. Tutt exhibited a series of *Hadena pisti*, comprising specimens very grey in tint, others of an almost unicolorous red with faint markings, and others well marked with ochreous transverse lines; three distinct forms of *Hadena dissimilis*; red and grey forms of *Panolis piniperda*, and a dark form of *Eupithecia fraxinata*; also a specimen of *Sciaphila penniana*.—The Rev. Dr. Walker exhibited specimens of *Arge titea*, *A. lachesis*, *A. psyche*, *A. thetis*, and other species of the genus from the neighbourhood of Athens; also specimens of *Argynnis phæbe*, taken in Grenada in May 1891.—Mr. W. Farren exhibited a series of specimens of *Peronea variegana* var. *civiana*, and *P. schalleriana* var. *latifasciata*, from Scarborough; *Eupithecia vectiana*, from Wicken Fen; and *Elachista subocellea*, from Cambridge.—Mr. G. A. J. Rothney sent for exhibition a number of species of ants collected in Australia, in May and June 1886, which had recently been named by Dr. Forel. The collection included: *Iridomyrmex purpureus*, Sm., *I. rufoniger*, Lowne, *I. gracilis*, Lowne, *I. itinerans*, Lowne, *Ectatomma metallicum*, Sm., *E. nudatum*, E. mayri, *Aphanogaster longiceps*, Sm., *Polyrhachis ammon*, Fab., *Myrmecia nigruentris*, Mayr, and *nigrocincta*, Sm.; and a variety of *Camponotus rufiginosus*, Mayr, from Brisbane; also a few species from Honolulu; and a species of *Monomorium*, which Dr. Forel had not yet determined.—Mr. C. O. Waterhouse read a paper entitled "Some Observations on the Mouth Organs of Diptera," which was illustrated by numerous diagrams.—Mr. E. Meyrick read a paper entitled "On the Classification of the Geometrina of the European Fauna." Mr. Hampson, Mr. Elwes, Mr. McLachlan, Colonel Swinhoe, Mr. Tutt, and Mr. Distant took part in the discussion which ensued.

Zoological Society, February 16.—Osbert Salvin, F.R.S., Vice-President, in the chair.—Mr. W. T. Blanford, F.R.S., exhibited two heads and a skin of the Yarkand Stag, lent for



exhibition by Major C. S. Cumberland, by whom they had been obtained, and proposed the name of *Cervus elaphus yarkandensis* for this form.—Mr. Sclater exhibited and made remarks on some living specimens of what are commonly called Spinning or Japanese Mice.—Mr. Sclater also exhibited and made remarks on some mounted heads of Antelopes from Somali-land, belonging to Captain Swayne, R.E., amongst which was an example of the recently described Swayne's Hartebeeste (*Bubalis swaynei*).—Mr. A. Smith-Woodward exhibited and made remarks on examples of the supposed jaws and teeth of *Botrio lepis* from the Upper Devonian formation of Canada.—Mr. F. E. Beddard read a paper containing the results of his examination of the Chimpanzee "Sally" and the Orang "George," lately living in the Society's Menagerie. The author's remarks referred principally to the external characters and the muscular anatomy of these Anthropoid Apes.—A communication from Mr. A. G. Butler gave an account of a collection of Lepidoptera from Sandakan, North-East Borneo.—Mr. G. A. Boulenger gave an account of a third collection of Fishes made by Surgeon-Major A. S. G. Jayakar at Muscat, East Coast of Arabia. Amongst these was a specimen of *Histiogaster typus*, a fish described in "Fauna Japonica," but not since recognized; and an example of a new species of *Box*, proposed to be called *B. lineatus*.—A communication from Dr. W. B. Benham contained a description of three new species of Earthworms from British Columbia and South Africa. These were proposed to be called *Plutellus perrieri*, *Microchata papillata*, and *M. belli*.—Mr. F. E. Beddard read a paper on some new species of Earthworms of the genus *Perichata*.—A communication was read from Dr. H. Bolau, on the specimens of *Helicidius pelagicus* and *H. branickii*, now living in the Zoological Gardens of Hamburg. Coloured drawings of these nearly allied Sea-Eagles were exhibited.

**Anthropological Institute, February 9.**—E. B. Brabrook, Vice-President, in the chair.—Mr. Walhouse exhibited the skull of a Dacot leader from the Chin country on the Burmese and Chinese frontier; also a quiver and several other Chin objects sent to him by Captain E. S. Hastings.—The following papers were also read:—On the exploration of Howe Hill Barrow, Duggleby, Yorkshire, by J. R. Mortimer; and on the human remains found in Howe Hill Barrow, by Dr. J. G. Garson.

**Royal Meteorological Society, February 17.**—Dr. C. Theodore Williams, President, in the chair.—The following papers were read:—The untenability of an atmospheric hypothesis of epidemics, by the Hon. Rollo Russell. The author is of opinion that no kind of epidemic or plague is conveyed by the general atmosphere, but that all epidemics are caused by human conditions and communications capable of control. In this paper he investigates the manner of the propagation of influenza, and gives the dates of the outbreaks in 1890 at a large number of islands and other places in various parts of the world. Mr. Russell says that there is no definite or known atmospheric quality or movement on which the hypothesis of atmospheric conveyance can rest, and when closely approached it is found to be no more available than a phantom. Neither lower nor upper currents have ever taken a year to cross Europe from east to west, or adjusted their progress to the varying rate of human intercourse. Like other maladies of high infective capacity, influenza has spread most easily, other things being equal, in cold calm weather, when ventilation in houses and railway-cars is at a minimum, and when, perhaps, the breathing organs are most open to attack. But large and rapid communications seem to be of much more importance than mere climatic conditions. Across frozen and snow-covered countries and tropical regions it is conveyed at a speed corresponding, not with the movements of the atmosphere, but with the movements of population and merchandise. Its indifference to soil and air, apart from human habits depending on these, seems to eliminate all considerations of outside natural surroundings, and to leave only personal infectiveness, with all which this implies of subtle transmission, to account for its propagation.—The origin of influenza epidemics, by Mr. H. Harries. The author has made an investigation into the facts connected with the great eruption of Krakatō in 1883, and the atmospheric phenomena which were the direct outcome of that catastrophe. He has come to the conclusion that the dust derived from the interior of the earth may be considered the principal factor concerned in the propagation of the recent influenza epidemics, and that, as this volcanic dust invaded the lower levels of the atmosphere, so a peculiar form of sickness assailed man and beast.—Report on

the phenological observations for 1891, by Mr. E. Mawley. This report differs in many respects from the previous reports on the same subject. Among other changes, the number of plants, &c., selected for observation has been greatly reduced, while the number of observers has considerably increased. The winter of 1890-91 proved in England very destructive to the root-crops, as well as to green vegetables and tender shrubs. Birds also suffered severely. In Scotland and Ireland, however, there was scarcely any severe weather until March. The flowering of wild plants was greatly retarded by cold in the spring, but during the summer the departures from the average were not so great. The harvest was late, and its ingathering much interfered with by stormy weather.—Note on a lightning discharge at Thornbury, Gloucestershire, July 22, 1891, by Dr. E. H. Cook.

## EDINBURGH.

**Royal Society, January 18.**—Prof. Chrystal, Vice-President, in the chair.—Prof. C. G. Knott read a paper on the magnetization of iron by a current passing through it. The experiments were an attempt to get some insight into the nature of circular magnetization as it exists in an iron wire carrying a current. Direct experiment seemed hopeless. Accordingly, tubes were used, in which the circular magnetization was measured by the induction current produced in a coil wound longitudinally round the wall of the tube. The circular magnetization could be produced either by an axial current along a copper wire threading the tube, or by a sectional current from end to end along the tube itself. Several tubes of different bores were used in pairs, the induction, axial or sectional, in one being balanced, by adjustment of resistances in the secondary circuits, against the induction, axial or sectional, under the influence of the same current in the other. The average magnetic force acting round the tube was calculated in accordance with the usual assumptions, and this, taken along with the observed induction, gave an average permeability. The general result was that the sectional induction accompanying a given current is greater by about 7 per cent. than it would be if the usual theory as to the relation between it and the axial current were accurate. Direct experiment appreciably showed that a current flowing through iron does not increase permeability to inductive forces acting perpendicular to the current, so that the deviation mentioned must be due to the faultiness of the theory. With greater current densities, such as exist in the circularly magnetized wire, this deviation may be even more pronounced.—A paper, written by Mr. R. W. Western, on tactics adopted by certain birds when flying in the wind, was read. In this paper an attempt was made to explain the advance of certain birds against the wind without motion of the wings.—A paper, by Dr. A. B. Griffiths, on ptomaines extracted from urine in certain infectious diseases, was communicated.—Prof. Tait read the second part of a paper on impact. In the series of experiments described in this part of the paper, blocks of the various substances dealt with, similar in shape to those used in the first set of experiments, but larger in size than they were, were used. The mass of the impinging body was also larger than formerly, and in some experiments the part of it which impinged upon the substance was made of a V-shape instead of flat. The paper contained a comparison of the present results with the former.—Prof. Tait also read a note on the critical isothermal of carbonic acid as given by Amagat's experiments. Throughout a considerable range of volume this isothermal is practically flat.

February 1.—The Rev. Prof. Flint, Vice-President, in the chair.—A paper by Dr. Piazzì Smyth, formerly Astronomer-Royal for Scotland, on the latest physical geography from Greenland, was read.—A paper, by Mr. R. Brodie, on the equilibrium and pressure of arches, with a practical method of ascertaining their true shape, was communicated. The method involves the use of a very simple and easily applied geometrical construction.—Prof. Tait read a note on the isothermals of mixtures of gases. In this note reference was made to a possible explanation of the flatness (indicated in Amagat's recent experiments) of the critical isothermal of carbonic acid near the critical point as due to the presence of a small quantity of air.

## PARIS.

**Academy of Sciences, February 22.**—M. d'Abbadie in the chair.—On a geometrical interpretation of the expression of an angle with two normals infinitely close to a surface, and on its

use in theories of the rolling of surfaces and gearings without friction, by M. A. Resal.—On the theory of elasticity, by M. H. Poincaré.—On the magnetic disturbance of February 13-14, by M. Mascart. It is stated that the instruments at the meteorological stations of Nice, Toulouse, Clermont, and Besançon were disturbed during the recent magnetic storm in the same manner as those at Perpignan, Lyons, Nantes, and Parc Saint-Maur. An account is also given of an aurora observed on February 14 by M. P. Lefebvre at Troyes, and M. de Roquigny-Adanson at Parc-de-Baleine.—Note on a sun-spot observed at Meudon Observatory from February 5 to February 17, by M. J. Janssen.—On the measurement of high temperatures; reply to some remarks made by M. H. le Chatelier, by M. Henri Becquerel.—Preparation of amorphous boron, by M. Henri Moissan. (See Notes.)—On an improvement of automatic arrangements for lifting water to great heights, employed in irrigation, by M. Anatole de Caligny.—Researches on ethyl monochlor-, monobrom-, and monocyanacetate, by MM. A. Haller and A. Held. The monohalogen derivatives of ethyl acetoacetate react sometimes as  $\alpha$  and sometimes as  $\gamma$  derivatives, and sometimes as a mixture of  $\alpha$  and  $\gamma$  derivatives.—On the deformation of the earth's crust, by M. Marcel Bertrand.—Photographs of the star Nova Aurigæ, taken at the Vatican Observatory, by M. F. Denza. Two negatives were taken of the region about Nova Aurigæ on February 7. The telescope was moved slightly in declination between successive exposures, so that each of the negatives obtained showed five images of the Nova. The star on the date of observation was said to be undoubtedly of the fifth magnitude. Its image is not so clearly defined as are the images of other stars on the same plates. Careful measurements of position made with the meridian instrument of the Observatory give the values R.A. 5h. 25m. 34s., Decl.  $30^{\circ} 21' 42''$ .—On algebraic integrals of differential equations of the first order, by M. Léon Autonne.—On maximum elastic deformation of metallic arcs, by M. Bertrand de Fontvioland.—Relation of the magnetic disturbance of February 13-14 to solar phenomena, by M. E. Marchand.—Researches on the realization of the spheroidal state in boilers, by M. A. Witz. Experiments have been made by the author to determine the duration of evaporation of water on heated metals.—On the solubility of tricalcic phosphate and hydrogen bicalcic phosphate in solutions of phosphoric acid, by M. H. Causse.—On the stereochemistry of diacetyl tartaric acid; a reply to a communication by M. Le Bel, by M. Albert Colson.—Thermal study of sodium isopropylate, by M. de Forcrand.—Tartronic acid and the tartronates of sodium and potassium, by M. G. Massol. The heat of combination of tartronic (oxymalonic) acid is greater than that of malonic acid under the same conditions. This result is similar to that obtained with oxysuccinic and succinic acids.—The specific gravities of textile fibres, by M. Léo Vignon.—On the vitality of germs of microscopic organisms in fresh and salt waters, by M. A. Curtis.—On some points in the embryology of *Oniscus murarius*, Cuv., and *Porcellio scaber*, Leach, by M. S. Jourdain.—Structure of the nervous system of the larva of *Styatiomyis strigosa*, by MM. F. Henneguy and A. Binet.—On nutrition during diabetes, by M. Hanriot.—Researches on the fall of the leaves of the vine and the ripening of grapes, by M. A. Muntz.—Remarks on a recent communication by M. J. Passy, as to the minimum perceptible quantity of some odours, by M. Charles Henry.

## BERLIN.

Physical Society, January 29.—Prof. Schwalbe, President, in the chair.—Prof. Lampe gave an account of the life and work of the late Prof. L. Kronecker; and Dr. Budde an address in honour of the late Astronomer-Royal, Prof. Airy.—Prof. König described experiments, made chiefly in collaboration with Dr. Ritter, on the luminosity of spectral colours under very widely different intensities of illumination. Special attention was directed to the curves of luminosity under very feeble illumination, a condition under which only the outermost red of the spectrum is visible.

Meteorological Society, February 2.—Dr. Vettin, President, in the chair.—Dr. Arendt spoke on the relationship of the electrical phenomena of the atmosphere to terrestrial magnetism. Neither the aurora nor the sudden discharges during thunderstorms have exhibited any regularity in their relationship to variations of terrestrial magnetism. The speaker's observations at the magnetic observatory of Potsdam, extending over a whole year, have shown that sudden luminosities in

the sky, which differ from ordinary sheet-lighting, but are certainly due to electrical discharges, and are most prevalent in winter, are always accompanied by changes of terrestrial magnetism. In connection with the above, Prof. Spoerer pointed out that the solar activity had undergone a sudden reversal in April 1891, in so far as since 1883 the southern hemisphere had been more active than the northern, in the ratio of 15 and 18 to 10, whereas since April the activity had markedly increased in the northern hemisphere, so that it had exceeded that of the southern in the ratio of 34 to 10.—Dr. Assmann gave a preliminary short account of some observations made in a captive balloon in January last during a dead calm and the lowest temperature of the winter. The balloon ascended slowly at 1 o'clock, and was slowly pulled down at 5 p.m.; and since it was found that the self-registering apparatus was in perfect working order, it was again allowed to ascend, and remained up until 11 p.m. During the whole afternoon the cable hung perfectly vertical, so that the balloon reached its full elevation of 750 metres. In the evening a slight south-easterly wind blew aloft, although the calm was continuous below. The temperature at midday at the earth's surface was  $-12^{\circ}$  C.; a few metres above the surface it rose  $0^{\circ}6$ , and was then constant up to a height of 250 metres, and as far as the fine mist extended. At greater elevations it rose rapidly, and at an elevation of 750 metres stood at  $-4^{\circ}$ . That this considerable elevation of temperature at the higher altitude was not due to solar radiation was shown by the fact that in the evening the temperature at an elevation of 700 metres was as much as  $12^{\circ}$  above that at the earth's surface. The data as to humidity and barometric pressure were less trustworthy.

Physiological Society, February 5.—Prof. du Bois Reymond, President, in the chair.—Dr. René du Bois Reymond gave an account of his researches with chloroform purified by crystallization at  $-100^{\circ}$ , and compared its action with that of ordinary chloroform and of the mother liquor from the crystals. Experimenting on frogs and rabbits, he found their action was practically identical.—Prof. H. Munk made a short communication on the function of the superior laryngeal nerve, on extirpation of the thyroid gland, and on a centrally blind monkey.

## CONTENTS.

	PAGE
Deep-Sea Deposits. By Prof. John W. Judd, F.R.S.	409
Parasitic Fungi and Moulds . . . . .	411
Our Book Shelf:—	
M'Clelland: "A Treatise on the Geometry of the Circle" . . . . .	412
Lucas: "Kalm's Account of his Visit to England on his Way to America in 1748" . . . . .	412
Letters to the Editor:—	
The University of London.—Prof. E. Ray Lankester, F.R.S. . . . .	413
Superheated Steam. (With Diagram.)—J. Macfarlane Gray; Prof. James A. Cotterill, F.R.S.; G. H. Bailey . . . . .	413
Poincaré's "Thermodynamics."—Prof. H. Poincaré The Theory of Solutions.—Prof. W. Ostwald . . . . .	414
A Lecture Experiment on Sound. (Illustrated.)—Reginald G. Durrant . . . . .	415
The Formation and Erosion of Beaches, &c.—A. R. Hunt . . . . .	415
Torpid Cuckoo.—A. Holte Macpherson . . . . .	416
A Swan's Secret.—Mrs. Jessie Godwin-Austen . . . . .	416
A Simple Heat Engine.—Prof. Konstantin Karamate . . . . .	416
New Extinct Rail.—Prof. Henry O. Forbes . . . . .	416
On a Recent Discovery of the Remains of Extinct Birds in New Zealand. By Prof. Henry O. Forbes . . . . .	416
The Blue Hill Meteorological Observatory . . . . .	418
Gustav Plarr . . . . .	419
Notes . . . . .	419
Our Astronomical Column:—	
The Warner Observatory . . . . .	422
Measurement of Solar Prominences . . . . .	422
The Australasian Association for the Advancement of Science . . . . .	422
The Draper Catalogue of Stellar Spectra. By A. Fowler . . . . .	427
University and Educational Intelligence . . . . .	428
Societies and Academies . . . . .	429

THURSDAY, MARCH 10, 1892.

## THE SCIENCE MUSEUM AND THE TATE GALLERY.

THE men of science of this country owe a deep debt of gratitude to Mr. Goschen. As a result of his careful inquiry into the questions raised by the suggested use, for Mr. Tate's gallery, of land bought for scientific purposes, he has decided that the scientific claim must hold good. It is impossible to over-estimate the importance of this decision. Had it been otherwise, the possibility of establishing in London an institution which should be for Science what the National Gallery is for Art and the British Museum Library for Literature would have been wrecked for a generation.

One can easily imagine that it was not easy for a Chancellor of the Exchequer to come to such a conclusion—not easy, that is, to one who was prepared only to look at the surface of things.

On the one hand, there was the tempting offer of £80,000 from a well-known public benefactor, about which large sum so much has been said that very few have thought it worth while to consider either the value of the plot or what capital sum would represent the annual outlay necessary to keep up the gallery when once built; an outlay which, of course, would fall upon the nation.

On the other hand, the Lord President of the Council, who is responsible for the Science and Art Department (and, as many people think, however erroneously, for the proper setting out and consideration of any national question touching Science or Art), seemed to be willing that Mr. Tate should have his way. Nor was this all; the Report of the Committee appointed by the Treasury a few years ago is so vaguely drafted that it now appears that the view which we and others took in discussing its recommendations at the time was incorrect. The question referred to this Committee dealt with the space necessary for the housing of the science collections which had been brought together as a nucleus for the Science Museum, the establishment of which was recommended in 1874 by the Duke of Devonshire's Commission. The Committee's Report recommended that 90,000 square feet *should be provided*. We and others naturally took this to mean that this was in addition to the existing space. The modern gloss, however, is that this represented the whole space necessary, in the opinion of the Committee, for a complete Museum dealing with all the inorganic sciences (except geology and mineralogy) and their industrial applications! It may even be that this idea has been placed before Mr. Goschen. If so, all the greater credit to him for having seen through the fallacy of a view which it is absolutely impossible can ever have been in the heads of the scientific members of the Committee.

As we pointed out recently, it is better not to deal with opinions in such a matter as this, if facts are available; they exist. The space considered necessary not very many years ago for the sciences represented in the Natural History Museum was 150,000 square feet, nearly double that already mentioned. In the case of these sciences, moreover, "industrial applications" cannot be exhibited at all—except, by the way, in the case of

geology, for which a special Museum exists in Jermyn Street.

One hundred and fifty thousand square feet being required, a plot of 500,000 square feet was provided; and it is quite certain that, at some not very distant time, the space not yet built on will be required. We cannot, therefore, call this generous appropriation unwise from the point of view of possible, or rather certain, future extensions; while all will agree that a national building of this class is all the better for standing a little away from noisy and dusty roads.

This, then, is the available fact with which we can deal, and we must again state whither it leads us; for in Mr. Goschen's letter to Mr. Tate, admirable though it is as a complete statement of the case, there is one phrase to which we must take exception. To show its force, we quote the whole sentence:—

"In conclusion, allow me to say that I can well understand that the difficulties in finding a suitable home for your collection, notwithstanding your munificent offer to build yourself, may not unnaturally have caused you some vexation. I think you will, however, admit that the Government have shown their desire to meet you in every possible way, and are willing to incur considerable outlay themselves in carrying out your plan. In the first instance, we not only offered the eastern and western galleries for housing British art, but adopted the plan of uniting them by a cross gallery, which seemed to remove many of the objections. When you came to the conclusion that the proportions given to the plan were not large enough or distinct enough to suit your views, and when you suggested the site at the corner of the Imperial Institute Road, I hoped that a solution had been found, and that this arrangement would meet with general acceptance. You are aware of the storm which followed, and though, in my own judgment, the Government land at Kensington was of so large an area that, by some understanding between the representatives of science and those of art, satisfactory means could be provided for assigning sites for every purpose, I was nevertheless so anxious that no obstacles should prevent the execution of your plans, that I consented to recommend the Government to incur a very considerable pecuniary liability if the Corporation of London should, on their part, offer the site on the Embankment on terms which were suggested to me as not impossible."

Now, the land at Kensington, of "so large an area," consists of something like 300,000 square feet, say three-fifths of the site occupied by the Natural History Museum: of this, Mr. Tate demanded roughly 100,000 square feet—thus leaving 200,000.

Of this, the new laboratories for physics, astronomical physics, and chemistry, if these are to be on the scale of similar institutions in a second-rate German town, will, including the necessary lighting spaces, &c., require 100,000 square feet. This leaves 100,000.

But this remainder, on which there is to be built a Science Museum, is less than two-thirds of the exhibiting space of the Natural History Museum as it stands at present, to say nothing of the total area devoted to it!

It is clear, then, that Mr. Goschen has not had the facts placed before him by those upon whom he has relied for his information. While the official prompting has tended one way, the opinions of the President and Officers of the Royal Society and other men of science have clearly tended another; and Mr. Goschen's final

attitude is, to a large extent, due to the weight which he has wisely and bravely attached to the latter.

"The proposal," he says, "has not met with the general acceptance which we anticipated for it. On the contrary, it is strenuously opposed by what appears to be the whole body of opinion representing scientific interests; and, although it might be possible to provide adequately for those interests and at the same time appropriate the site proposed to the British Art Gallery, I cannot say that the discussions in that sense with which we have for some time been occupied have so far had any effect in diminishing opposition from those quarters."

The opposition has, we may remark, not changed because the facts have not changed, and we do not think it would have been started if any *modus vivendi* had been possible.

And here we approach a side of the question which shows that as the world grows older, questions of science and art are not managed in this country any better than they used to be, and that some radical change is necessary in our manner of dealing with them. A correspondent of the *Pall Mall Gazette* ascribes this to *Tory government*. It is easy to see that the administrative system and not party government is to blame.

Mr. Goschen, in his letter, states that Mr. Tate himself suggested the site on the science ground, and it may be that some friends of science have said or thought hard things of Mr. Tate in consequence.

Mr. Tate replies:—

"I did not suggest the site at the corner of the Imperial Institute Road, and was only aware of it when it was pointed out to me as the plot offered by the Government as a desirable site for the Gallery of British Art, and with that site I expressed myself satisfied."

It must therefore be taken that it was the Government itself that offered the site. Did the Government offer first and consider afterwards? for Mr. Goschen now admits that it "would not be wise to assign this corner site to the Gallery of British Art." Another point can be best stated by again quoting from Mr. Goschen:—

"When it [the scheme] was first mooted, the intention was that works of British painters from the National and South Kensington Galleries should be transferred to the new gallery. It has since been ascertained that the trustees of the National Gallery are not disposed to fall in with this intention, and that the Science and Art Department is precluded by the terms of its various trusts from parting with many of its most important works."

The Science and Art Department is not more "precluded" now than it was when the land was offered to Mr. Tate. The preclusion dates from 1857, and it apparently was not known to those who, as it would now seem, without consulting the Science and Art Department, were ready both to hand over pictures and land.

We give these two instances as indications of the result of the present system of dealing administratively with such questions.

We have already stated that the scientific world is under great obligations to Mr. Goschen; but we must also point out that the President and Officers of the Royal Society, and the other men of science who memorialized Lord Salisbury and attended the deputation, have rendered a service to science worthy of the high position they hold.

There are men of science employed at South Kensington, it is true; but they, as we have said before, have no official voice in such matters as these.

Since it seems we may now hope that the land has been saved for scientific purposes, it is much to be desired that some representative of science in the House of Commons should move for a Committee on which the Treasury and the Office of Works, the Science and Art Department (though judging from recent events the last-named is too frequently ignored when questions directly connected with its duties are under consideration), together with the Royal Society and the Professors of the Royal College of Science, may be represented.

Mr. Goschen's answer on Monday to Dr. Farquharson's question as to what steps had been taken to provide for the building of the Science Museum, and for the extension of the Royal College of Science so urgently required, shows us clearly that it will be some time before the teaching at South Kensington will have passed through its present camping-out stage.

Mr. Goschen acknowledges that

"it has been impossible to take any steps towards beginning the erection of a Science Museum or the extension of the Royal College of Science until the question connected with the British Art Gallery had been settled. I myself had visions of a scheme, independently of building on the controversial corner, which I had thought might have given ample satisfaction both for the present and future to the scientific world, but the matter will now have to be reconsidered."

In answer to another question Mr. Goschen admitted that the scientific work at South Kensington is at present cramped, and stated that, in conjunction with the Commissioner of Works, he would endeavour to find some temporary buildings to meet the difficulty before the final scheme is adopted.

Let us hope that, some time before another generation has passed away, the "administration" which has led to the present *impasse* may be ameliorated, and that useful buildings on the site may prove to everybody the justice of the views held by the men of science in this matter.

#### THE CORRESPONDENCE OF CHRISTIAN HUYGENS.

*Œuvres Complètes de Christiaan Huygens.* Publiées par la Société Hollandaise des Sciences. Tome quatrième, Correspondance 1662-63. (La Haye: Martinus Nijhoff, 1891.)

THE fourth volume of the Huygens correspondence covering the years 1662-63, is now before us. Although the interval, as regards fresh discoveries by the "Dutch Archimedes," was a comparatively barren one, the 249 letters referable to it (to say nothing of supplementary documents) afford materials for much instruction, and some entertainment. It is much to learn that the greatest astronomer of his time sought to keep in touch with Paris in respect to the cut and colour of his clothes; nor can we be indifferent as to the precise date of his beginning to wear a wig. On June 15, 1662, at the age of thirty-four, he communicated to his brother Constantine the distressing intelligence of his incipient baldness; a remedy for which, in the shape of the best *perruque* to be had in Paris, was provided in the following

October. A similar article of attire, despatched by him to the Hague for his elder brother's wear, figures in several letters, and engaged many anxious thoughts; but a little plot concocted by the *par nobile fratrum* for extracting the price—amounting to four and a half louis—from the liberality of their father, the Secretary, appears to have been baffled. They were, indeed, often made to feel—though not with any unreasonable harshness—that he who keeps the purse holds the reins; for the paternal authority exercised in their family was of no shadowy kind. The elder Constantine ordered his three sons—middle-aged, in Dante's sense, though they were—from realm to realm at his good pleasure, and was obeyed without hesitation. And notwithstanding that his demands from Paris for optical toys—pocket-telescopes, magic-lanterns, and the like—gave Christian considerable annoyance, he did not venture to refuse, or so much as remonstrate against the fulfilment of paltry, troublesome, and, to his sentiment, humiliating commissions. He, however, stooped instead to the scarcely laudable subterfuge of begging his brother Louis, then in Paris, to abstract one of the three lenses of the lantern, and so bring about at least a postponement of his father's appearance at the Louvre in the character of showman to scientific "marionettes," no longer claiming even the distinction of novelty.

Huygens spent the whole of 1662 in Holland, occupied mainly with experiments on the "weight and spring of the air." Pneumatic inquiries just then, largely through Boyle's example, raised very general curiosity; and pneumatic engines attracted much constructive ingenuity. The mode of creating *vacua* had been recently arrived at; phenomena of an unforeseen kind thence ensued, and led to continual surprises; their investigation involved that of the qualities and functions of the air; upon which the learned, accordingly, promptly and eagerly entered. Huygens among the number; yet with no result of the first order of importance. He fabricated an improved air-pump; and observed by its means some apparently anomalous effects, which occupied many of his thoughts, and gave rise to an extensive correspondence, both with French *savants*, and with Sir Robert Moray as the representative of the Royal Society of London. They did not, however, prove to possess all the significance which he was at first disposed to attach to them. Less than his customary success, also, about this time attended his efforts to give to pendulum-clocks the perfection needed for the solution of the problem of longitudes. His coadjutor was the ingenious Alexander Bruce, a few months later Earl of Kincardine, who, with unlucky result, took a pair of the carefully-adjusted timepieces on a trial voyage from the Hague to London in December 1662. The sea was rough; the ship a small one, but with large capacities for rolling and pitching; whereby a test more searching than tolerable was applied to the novel mechanism. One clock, thus "furiously shaken," lost the bob of its pendulum; the other stopped, and their custodian, having succumbed to sea-sickness, could do next to nothing to remedy the damage. Evidently, the purpose in view demanded some better invention, such as, indeed, Robert Hooke had already hit off, but, after his usual volatile fashion, had thrown, still incomplete, aside.

On arriving in Paris, April 3, 1663, the first care of our

mathematician was to have himself bled, in order to get rid the sooner of a cold caught on the journey of six full days from Brussels; and the operation, singularly enough, produced the intended effect. His next desire was to place himself *au courant* of the state of practical optics in the French capital, and to compare his lenses with those ground and polished by Auzout and D'Espagnet. The handiwork of the latter excited his particular admiration; but the secret of his methods was carefully guarded, and Huygens records, with a perceptible shade of irritation, the vigilance of the Bordeaux alchemist over a case of lenses which might, for the care bestowed in keeping them tucked under his arm, have been a box-full of pistoles. He found, however, "Messieurs les Lunettiers" less advanced than he had expected in their grand schemes for telescopes 80 and 100 feet in length.

He set out with his father for London on June 7, and both were present three days later at a meeting of the Royal Society, where they were entertained with "occasional observations," and "promiscuous discourses," relating to petrifications, the smutting of corn, the amelioration of flowers, and sundry other topics. Christian testified his usual courteous interest in the proceedings; but expressed, none the less, in one of his confidential letters to his brother Constantine, something of scorn for the miscellaneous doings at Gresham College. And he felt himself, he said, no whit the wiser for his election as a Fellow of the Society on June 17, 1663. English festivities, however, he admitted to be splendid. "This is the true land of good cheer," he wrote, after a succession of dinners given by the Earls of Manchester, Albemarle, and Devonshire, all of which were outdone by the brilliant hospitality at Roehampton of the Dowager Countess of Devonshire. A Court ball evoked no special comment; and perhaps Huygens's most genuine interest in London was in his visits to Sir Peter Lely's studio. Both he and Constantine dabbled about that period in pastels, and the recipe by which Lely's crayons were fabricated was an object of eager desire to them. It was freely imparted, and is here printed (p. 372).

Huygens quitted London on October 1, and spent the remainder of the year in Paris. And since his movements were regulated, not by the claims of science, but by family arrangements, his letters thence referred to no critical problems of that age. They are accordingly more "readable," in the general sense, than might have been expected from a geometer of his profundity; those addressed to his brothers, which form the majority in the present volume, being even playful and diverting. To them he showed himself without disguise. He sent them jively *causeries*, rather than formal epistles; social jottings, family intelligence, the first hints of his anticipated triumphs, his unvarnished opinions of his contemporaries: they alone were allowed to see that there was a keen edge to his wit. His erudite correspondents on occasions put him fairly out of patience; yet to Louis Huygens alone was it confided that he thought Chapelain intolerably tedious, and Petit uncommonly dull. Constantine, on the other hand, was the recipient of his impressions touching the harpsichord performance of William Brereton, a distinguished member of the Royal Society. Its effect upon a trained musician like Huygens can easily be gathered from the ominous facts that the player was

self-taught, and executed fantasias chiefly remarkable for their disregard of every known rule of composition. Touches of family affection here and there relieve the intellectual pre-occupation lending its prevalent stamp to the Huygenian correspondence. One likes the great man better for his questions about the walking and talking achievements of his little niece, Gertruid Doublet, than for having solved the problem of the centre of oscillation, or discovered the isochronism of the cycloid. The maiden's modest proficiency was not carried to a high pitch. She died in 1665, at the age of four.

In the way of astronomy, Huygens did nothing of much moment during this interval. Admonished by Boulliaud of its visibility, he made his first observation of Mira Ceti at the Hague, on August 15, 1662, when it was nearly as bright as  $\kappa$  Ceti (fifth magnitude). The next account of the star is on September 15, three weeks at least after a maximum; and its declining state seemed to Boulliaud marked by the flaring and flashing of its light, as if in truth a semi-extinct conflagration revealed itself in his telescope. "C'est un spectacle," he adds, "à faire désespérer Aristote et ses disciples" ("Corr. de Huygens," t. iv. p. 231). Occasionally, too, Huygens pointed out the sustained conformity of the Saturnian appearances to his theory of them. The logic of fulfilled prediction had, indeed, by this time persuaded all but the few outlanders always averse to conviction by truth, that the hypothetical and the real systems were practically identical.

The two years embraced by the present section of this grand work were exceedingly peaceable ones. The gates of the Temple of Janus in the republic of letters remained fast shut as they slipped by. Scarcely a ripple of contention stirred. Everyone was in good humour, and carped at his rival's doings only *sotto voce*—a state of things peculiarly agreeable to our Batavian philosopher, who loved not to have his meditations broken in upon by the shrill outcries of wounded self-love. Could it but have continued! But that was not to be.

A. M. CLERKE.

### THE HORSE.

*The Horse: A Study in Natural History.* By William Henry Flower, C.B., F.R.S., &c. (London: Kegan Paul, 1891.)

IF there be a fault in the admirable little volume which Prof. Flower has contributed to the "Modern Science" series, it is that the author too cautiously withholds his opinion on certain broad biological questions in which not only naturalists but the general reading public are just now specially interested. Early in the first chapter, for example, we read:—

"In many organs, but especially in the limbs and teeth, we find the strongest evidence of two opposing principles striving against each other for the mastery in fashioning their form and structure. We find *heredity*, or adherence to a general type derived from ancestors, opposed by special modifications of or derivations from that type, and the latter generally getting the victory, although in the numerous rudimentary structures that remain there is significant evidence of ancestral conditions long passed away. The various specializations, evidently in adaptation to purpose, will be thought by many to be the result of the survival, in the severe struggle for exist-

ence, of what is best fitted for the purpose to which it is to be applied. This may or may not be the explanation, but the interest of the study of such an animal as the horse will be increased tenfold by the conviction that there is some true and probably discoverable causation for all its modifications of structure, however far we may yet be from the true solution of the methods by which they have been brought about."

Here natural selection is not so freely and fully accepted as many would wish. But the grounds of doubt are not indicated. On the other hand, use-inheritance fares worse. It is not so much as hinted at. It is well known that there are, especially in America, biologists of standing who contend that differentiations of structure are largely due to a Lamarckian factor in evolution; and they adduce specialization of tooth-structure and of limb-structure as evidence of the inherited effect of mechanical strains and stresses. Now, in the horse specialization in teeth and limbs has been carried far. The general public and not a few biologists would, we think, have been glad to learn the opinion of the Director of our National Museum as to the scientific value of such views in so far as they apply to the subject of his "study."

On another point of very general interest Prof. Flower does, however, express an opinion. It has been suggested that the horse has been separately evolved in America and in Europe through a parallel but not identical series of ancestral forms. The evidence for this hypothesis is generally regarded in this country as insufficient, and it is now held that the horse was probably evolved on the Western Continent. This is the view adopted, with his accustomed caution, by the author of this book.

"It is," he says, "by no means impossible that America may have been the cradle of all the existing *Equide*, as it seems to have been of such apparently typical Old World forms as rhinoceroses and camels, and that they spread westward by means of the former free communication between the two continents in the neighbourhood of Behring's Straits, and, having prevailed over the allied forms they found in possession, totally disappeared from the country of their birth until reintroduced by the agency of man. This supposition, based upon the great abundance and variety of the possible ancestral forms of the horse which have lately been discovered in America, may be at any time negated by similar discoveries in the Old World, the absence of which at the present time cannot be taken as any evidence of their non-existence."

The discovery in the Old World of ancestral Perissodactyles, in numbers at all comparable to those which have been found in America, would no doubt throw a flood of light on difficult questions of evolution and distribution. If, as Madame Marie Pavlov has suggested, Sir Richard Owen's *Hyracotherium* is (perhaps) identical with Prof. Cope's *Phenacodus*, similar genera have existed on either side of the Atlantic since early Eocene times. In both continents these early forms presumably left descendants. Between the primitive *Phenacodus* and the existing horse there are many intermediate forms, some of which seem to be generically identical in America and in Eurasia. Have there, then, been many successive migrations from the West? Have there been counter-migrations from East to West? What have been the relations between the indigenous descendants of *Hyracotherium* and the successively immigrant descendants of *Phenacodus*? These and other questions may possibly

receive some sort of tentative answer through the researches of the palæontologists of the future. Prof. Flower is no doubt wise in not attempting to theorize on the subject; but this is the kind of question on which, in our experience, the "intelligent layman," whom the editor of the "Modern Science" series has in view, most greedily seeks information. Details of structure, no matter how clearly and lucidly described, do not appeal to him. He says, in effect, to the distinguished man of science: "My dear sir, from *you* I can take the details on trust; of them give me only sufficient to illustrate your methods of research: what I really want is your opinion on those broad general problems in which every man of liberal culture, who follows the thought of his time, must take a keen interest."

Prof. Flower divides his book into four chapters, of which the first deals with the horse's place in nature, and its ancestors and relations. The second chapter is devoted to the horse and its nearest existing relations. This contains a short account of the tapirs and the rhinoceroses, as well as the existing members of the horse tribe. The cuts with which it is illustrated are from photographs, and are admirable. The last two chapters (iii. and iv.) deal with the structure of the horse, chiefly as bearing upon its mode of life, its evolution, and its relation to other animal forms, the head and neck and the limbs being selected for detailed treatment.

Especially interesting are the paragraphs on the *ergot*, a roundish bare patch in the fetlock covered with rough thickened epidermis. It is suggested, and the suggestion is both valuable and interesting, that this represents

"the palmar or plantar pads of those animals which walk more or less on the palm and sole. Owing to the modified position of the horse's foot, standing only on the end of the last joint of the one toe, this part of the foot no longer comes to the ground, and yet the pad with its bare and thickened epidermic covering, greatly shrunken in dimensions and concealed among the long hair around, and now apparently useless in the economy of the animal, remains as an eloquent testimony to the unity of the horse's structure with that of other mammals, and its probable descent from a more generalized form, for the well-being of whose life this structure was necessary."

Of the other callous patches, the so-called "chestnuts," or "mallenders" and "sallenders" which occur on the inner aspect in the fore-limb just above the "knee," and in the hind-limb just below the "hock," Prof. Flower says that their signification and utility are complete puzzles.

There are one or two misprints or inelegancies which will probably be removed in a second edition. On p. 52 we read: "The upper molars have a very characteristic pattern, admirably adapted for bruising and crushing coarse vegetable substances, and which is clearly a modification of the pattern," &c. Another redundant and before which occurs in the very awkward sentence on the top of p. 136. A somewhat quaint misprint occurs on the top of p. 68, where the "various species of the American general called *Merychippus* and *Protohippus*" are spoken of. One can imagine how the printer's devil prided himself on his knowledge of American proclivities. They give the name "general" even to an ancient fossil equine!

C. L. L. M.

#### OUR BOOK SHELF.

*A System of Sight-Singing from the Established Musical Notation, based on the Principle of Tonic Relation.* By Sedley Taylor, M.A. (London: Macmillan and Co., 1891.)

THIS book is divided into two parts: (I.) the tonic sol-fa notation, (II.) the staff notation. Part I. differs from the "official" tonic sol-fa system only in the method of writing music in the minor key. Mr. Taylor is an out-and-out tonicist, and therefore most strongly opposed to the so-called "Lah mode" of the official system. It must be allowed that Mr. Taylor's method has the merit of consistency. For practical purposes, however, it is not so certain that the "Lah mode" is a mistake. At any rate, the opinion of most tonic sol-faists appears to be in its favour, as being the best method, from a utilitarian point of view, of treating the minor mode.

Part II. is an application of the tonic system to the ordinary staff notation. Mr. Taylor suggests that the line or space on which the tonic falls should be clearly marked by a thick line, of varying colours for major and minor keys. As long as there is little or no modulation in the music, there can be no objection to this, but when modulation sets in, the appearance which the stave assumes when these lines are inserted, becomes most puzzling. Two examples taken at random from the book will suffice to show this. In Ex. 142 the Do-line changes 6 times in the space of 9 bars of 2-4 time. Ex. 147, in 4-4 time, has 5 changes in as many bars.

It appears to us that these constant guides are calculated only to worry instead of directing the singer; "the graphic up-and-down-ness of the pitch-notation of the staff" (to use Mr. Taylor's words) seems to us to point out the way just as well without as with their assistance.

The book is most clear, logical, and interesting throughout; and whether one agrees with the reforms proposed in it or not, one cannot help feeling that the author, in his endeavours to minimize the difficulties of vocal music, deserves the thanks of all musicians.

*The Statesman's Year-book for the Year 1892.* Edited by J. Scott Keltie. (London: Macmillan and Co., 1892.)

THE "Statesman's Year-book" is too well known, and too highly appreciated, to need the commendation of reviewers. It presents such great masses of important facts, and these are generally so accurate and so well arranged, that the work has become indispensable to all who desire to obtain the latest information on the various subjects with which it deals. The changes for the year 1892 are described as "heavy and extensive," and all of them, we need scarcely say, add to the usefulness of the volume. The date of issue was somewhat later than usual; but it was well worth while to postpone publication, as the delay enabled the editor to include, among other valuable statistics, the results of the censuses of the leading countries of the world. This year the volume has been enriched with four admirably executed maps. They relate respectively to the density of the population of the globe on the basis of new censuses and estimates, the distribution of the British Empire over the globe, the partition of Africa, and the international frontiers on the Pamirs. These maps are most welcome, and will be of great service to all who may have occasion to refer to them.

*The Optical Lantern as an Aid in Teaching.* By C. H. Bothamley. (London: Hazell, Watson, and Viney, Limited, 1892.)

THOSE who wish to acquire a general knowledge with regard to the manipulation of an optical lantern, without

entering into the minor details, will find in this little book a most useful guide. The author has dealt with the subject rather curtly, but nevertheless in this space the reader will find descriptions of various lanterns for different methods of projection; hints on the most suitable positions in which screens should be placed to be best viewed by audiences; the best kinds of burners for the lamps, both oil and oxy-hydrogen, and the different adjustments for producing good results. Many other useful hints are given, accompanied by several woodcuts. W.

### LETTERS TO THE EDITOR.

[The Editor does not hold himself responsible for opinions expressed by his correspondents. Neither can he undertake to return, or to correspond with the writers of, rejected manuscripts intended for this or any other part of NATURE. No notice is taken of anonymous communications.]

### Heat-Engines and Saline Solutions.

MR. MACFARLANE GRAY (p. 414) appears to call in question my assertion that in a vapour-engine a saline solution may take the place of a simple liquid when it is desired to replace water by a substance of less volatility, and that the advantage which Carnot proved to attend a high temperature can thus be attained without encountering an unduly high pressure. He contends that "the saline mixture is not the working substance. Carnot's law refers to the working substance only, and not to anything left in the boiler."

Perhaps the simplest way of meeting this objection is to point out that Maxwell's exposition of Carnot's engine ("Theory of Heat," chapter viii.) applies *without the change of a single word*, whether the substance in the cylinder be water, mercury, or an aqueous solution of chloride of calcium. In each case there is a definite relation between pressure and temperature; and (so far as the substance is concerned), all that is necessary for the reversible operation of the engine is that the various parts of the working substance should be in equilibrium with one another throughout.

Let us compare the behaviour of water in Carnot's engine before and after the addition of chloride of calcium, supposing that the maximum and minimum pressures are the same in the two cases. The only effect of the addition is to raise both the superior and the inferior temperatures. The heat rejected at the inferior temperature may still be available for the convenient operation of an engine working with pure water. At the upper limit, *all* the heat is received at the highest point of temperature—a state of things strongly contrasted with that which obtains when vapour rising from pure water is afterwards superheated.

RAYLEIGH.

### Superheated Steam.

LORD RAYLEIGH touches on a most important question (February 18, p. 375), which merits the attention of all interested in the economy of prime movers. Few have troubled themselves with determinations of temperatures and pressures within a steam generator. Ebullition means work, and the performance of work involves cooling; hence the temperature of steam in the steam space of any boiler is lower by several degrees than the temperature of the steaming water. I have failed to find any record of this important truth, and shall be glad to know if my observations have been anticipated.

Prof. Cotterill, in his work on the steam-engine (p. 33), referring to the process of formation of steam under rising pressure in a closed vessel, says:—"The mixture of steam and water must be supposed so treated that the temperature is sensibly uniform. If the experiment were tried without proper precautions, the steam would probably be found to be of higher temperature than the water—that is, it would be superheated." So far as my observations go, this is impossible, and the steam is never superheated by compression in a closed vessel, in contact with water.

In a small experimental boiler the records of temperature indicated as follows:—

### Temperatures in Model Boiler working up to 10 pounds pressure

Water temperature 1½ inches below upper level.	Steam temperature. Thermometer in steam space.	Pressure, pounds per square inch.
° F.	° F.	
100	87	—
120	106	—
140	126	—
158	145	—
174	164	—
188	179	—
200	192	—
212	205	—
215	212	—
226	222	5½
236	233	9½
239	235	10
239	235	10
239	235	10

To avoid supersaturation of the steam it must be separated as promptly as possible from the water, which it projects, more or less, into the steam space. It is this which renders it so important in practice to secure the most active circulation. Provision for this, whereby the water falls, whilst the steam rises, can be made.

Uniformity of temperature of the boiler contents is of the utmost importance; and I was recently told by an able engineer, connected with the Midland Railway, that the unequal expansion of the boiler plates in locomotives on getting up steam was not only disastrous in its consequences, but *impossible* of prevention. Pursuing thermometric experiments, I found this not to be the case, and on a first trial of suitable apparatus, I obtained the following result:—

### Model Locomotive Boiler, showing Hottest Water at the Bottom under 212° (October 24, 1891).

Upper level above fire...	60	80	90	100	110	120	130	140	150
Temperature below furnace	60	65	70	76	82	90	96	107	114
Upper level above fire...	160	170	180	190	196	198	199	204	209
Temperature below furnace	122	134	156	176	200	204	206	208	209
Upper level above fire...	212	212	—	—	—	—	—	—	—
Temperature below furnace	210	212	—	—	—	—	—	—	—

Lord Rayleigh's suggestion to use liquids of higher boiling-point than water, such as saline solutions, to get hotter steam whereby to raise the upper limit of temperature in a steam-engine, is not feasible. Increased elasticity of steam or increased tension was long since shown by John Sharpe ("Annals of Philosophy," vol. i. p. 459, 1813) to be due to a corresponding increase in its density. He pointed out that at 212° the density of steam was 150 times greater than at 32°, and at 252° it was twice as great as at 212°. Increasing the density of the liquid does not help us, but liquids of lower boiling-point yield vapours of higher density than steam at equivalent temperatures. Anhydrous ammonia vapour exerts a pressure of 4 atmospheres at 32°, and its density is about 0·2, whereas at 120° F. the pressure is in round figures 285 pounds on the square inch, and its density 0·850.

### Properties of Saturated Steam as compared with Saturated (Anhydrous) Ammonia Vapour.

Steam.			Anhydrous ammonia.		
Pounds per square inch above the atmosphere.	Temperature in ° F.	Weight of steam in pounds per cubic foot.	Pounds per square inch above the atmosphere.	Temperature in ° F.	Weight of vapour in pounds per cubic foot.
15	249·8	·07344	14·744	0	·1060
30	273·9	·10790	32	20	·1639
60	307·2	·17493	57·607	40	·2428
120	349·8	·30503	113	70	·4096
165	372·8	·40053	164·7	90	·5587



Regnault, Frost, Fairbairn, Tate, and others have shown that the rate of expansion of superheated steam is almost identical with that of air and other permanent gas, if calculated not too close to the temperature of maximum saturation. In passing steam through pipes heated by the hot gases from the furnace, the effect is not much, if any, better than using a trap to separate the water of condensation.

It is obvious that, for steam to pass from a boiler into a superheater, the latter can only be at the same pressure as the boiler, or somewhat lower, and the gasification in transit is not attended by increased density nor exalted tension; hence the failure of ordinary superheaters.

Practical engineers—makers of high-pressure engines for the trade—discovered long since that compression of steam at the end of each stroke, or steam cushioning, notwithstanding certain theoretical disadvantages, yielded an average efficiency greatly in excess of free discharge of steam from the cylinder. In this case superheating, of course, occurs, by compression, under circumstances insuring exalted tension; hence the economy. Hook's law, "Ut tensio vis," cannot be translated into "Ut calor sic vis."

JOHN GAMGEE.

The Laboratory, 3 Church Street, Westminster, S.W.,  
February 23.

### Poincaré's "Thermodynamics."

I FEAR M. Poincaré has not read my review of his book with sufficient attention. Otherwise he could hardly have written the letter printed in your last number.

The chief objections I made, taken in the *reverse* order of their importance, were

1. The work is far too much a mere display of mathematical skill. It soars above such trifles as historical details, while overlooking in great measure the experimental bases of the theory; and it leaves absolutely unnoticed some of the most important branches of the subject.

[Thus, for instance, Sadi Carnot gets far less than his due, Rankine is not alluded to, and neither Thermodynamic Motivity nor the Dissipation of Energy is even mentioned.]

2. It gives an altogether imperfect notion of the true foundation for the reckoning of absolute temperature.

3. It completely ignores the real (*i.e.* the statistical) basis of the Second Law of Thermodynamics.

If these are what M. Poincaré alludes to as "reproches généraux, contre lesquels ma préface proteste suffisamment," I can only express genuine amazement that a Preface should be capable of having such powers, and envy the man who is able to write one.

As to smaller matters:—I did not attack M. Poincaré's printer. I virtually said he was excusable under the circumstances. And as to the quite subsidiary question which M. Poincaré seems to think I regard as the most important, I have only to say that I could scarcely be expected to know that the words "on n'a pu jusqu'ici constater l'existence des forces électromotrices, &c.," imply, as M. Poincaré now virtually interprets them, "One has not yet been able to assign the origin of the electromotive forces, &c."

P. G. T.

4/3/92.

### The Function of a University.

YET one more definition—it is no part of the business of a University to teach, says Prof. Fitzgerald in NATURE of February 25 (p. 392). We have now the following definitions of the function of a University:—

1. It should be a mere examining body, *e.g.* the London University.

2. It is a place for the cultivation of athletics, good breeding, and gentlemanly behaviour.

3. At the University there should be taught classics, mathematics, and pure science.

4. The Professors of the University should teach *useful* subjects like mechanical and electrical engineering, medicine, &c., as at Cambridge.

5. The true function of the University is the teaching of *useless* learning.

6. It is no part of the business of a University to teach.

Truly, a wide choice of definitions, and seeing that the teaching of applied science which has been developed "at schools, technical colleges, by patent-mongers and the trade,"

aided "by a lot of savages," has been recently appropriated by the Universities, I have no doubt, that these degraded mortals have similarly worked out a system of teaching applied literature, that a seventh definition of the function of a University will be added later on, *viz.*—

7. At the University, modern languages and literature are studied in such a way as to be of the greatest value to the nation at large.

As Prof. Fitzgerald relegates the teaching of things useful to the class of pariahs mentioned above, perhaps he will tell us whether he raises the study of mechanical and electrical engineering to the lofty position of uselessness, or whether he utterly condemns the appeal that is now being widely made—made even to technical teachers—for aid in the establishment of engineering laboratories at a University which has recently thought that the best place to obtain an assistant was a London technical college.

He thinks that students, "if they are so ill prepared that they have not acquired the art of learning, should go to a College, . . ." and not to the University. I presume, then, that they ought to go, for example, to the Colleges of Trinity or St. John's, but not to Cambridge; or to the Colleges of Balliol or Christ's, but on no account to Oxford. Perhaps this somewhat conflicting advice is the result of Prof. Fitzgerald's studying literature "for its own sake," as contrasted with studying language for the sense it conveys. Examples were recently given in a leader in one of the daily papers illustrating that the public utterances of some of the most prominent advocates of the compulsory teaching of Greek conclusively proved that it was not to improve their English that they had studied the classics.

In the same lucid way Prof. Fitzgerald adds: "The Bible produced very little effect until it was read in translations; and the danger of a pagan revival, if ancient literature were studied without the obstruction of difficult languages, is the best reason for insisting on those languages in a Christian University." Surely a man of his wide intellectual power cannot mean that the general reading of the Bible, which became possible after it was translated into modern languages, is to be deplored. But neither, on the other hand, can he mean that the incalculable benefit, that has resulted from the translation of the Bible into the vulgar tongue is an argument for the suppression of free translation. On whichever horn of his own dilemma he decides to pose himself, I, at any rate, have no sympathy with the Roman Catholic dogma that good comes from making the knowledge of the truth difficult of attainment by the world at large.

He chides me with forgetting the debt electrical science owes to those who studied it while useless. Does the statement that one Volt sends one Ampere—that is, one Coulomb per second—through one Ohm look as if the practical electrical engineer had forgotten the labours of Volta, of Ampère, of Coulomb, and of Ohm? Indeed, is not Prof. Fitzgerald himself forgetting the deep debt of gratitude the theoretical study of electricity owes to its practical applications? The late Prof. Fleeming Jenkin, a Professor at a University bear in mind, wrote in 1873:—"In England at the present time it may almost be said that there are two sciences of electricity—one that is taught in ordinary text-books, and the other a sort of floating science known more or less perfectly to practical electricians. . . . A student might have mastered Delarive's large and valuable treatise, and yet feel as if in an unknown country and listening to an unknown tongue in the company of practical men. It is also not a little curious that the science known to the practical men, says, so to speak, far more scientific than the science of the text-books."

While there are University Professors like Thomson, Hertz, and Fitzgerald, what matters it whether we call them the *teachers* or ourselves the *learners*? When the work they are now carrying on may be of incalculable service to the practical man in the future, of what avail is it to discuss whether it is today *useful* or *useless*? For the labours of such men I have too profound a respect and admiration to "sneer" at what I hold to be the true function of the University.

But equally worthy of respect do I think is the *teacher* in a school of engineering—that is, one who aims at presenting useful knowledge, and the methods for extending it, in such a form as to be most easily grasped by those who intend to devote their lives to engineering.

My friend Prof. Fitzgerald and I are at any rate wholly in accord on one important point urged in my recent inaugural address, *viz.* that it is the special function of the technical school to teach *useful* knowledge.

W. E. AYRTON.

### Sir R. Ball's "Cause of an Ice Age."

SOME books appear under such authoritative sanction that, apart altogether from their arguments and their facts, they naturally influence opinion. This must be said of a book recently reviewed in your pages (January 28, p. 289); namely, "The Cause of an Ice Age," by Sir Robert Ball, the first of a series on modern science, edited by Sir John Lubbock.

The position taken up in this work is so much at issue with the views of many prominent geologists, and its general tendency seems so retrograde, that I am a little surprised it has not been adversely criticized.

I do not propose in this letter to enter into the general question as to the astronomical causes of an Ice Age, or whether an Ice Age can be shown to be a consequence of a varying eccentricity, upon which Croll and others have spoken very emphatically. I would rather limit myself to the particular new factor which Sir R. Ball has added to the problem. He claims that he has shown, and I do not contest the matter in any way, that, "of the total amount of heat received from the sun on a hemisphere of the earth in the course of a year, 63 per cent. is received during the summer, and 37 per cent. is received during the winter." This law he claims as "the fundamental truth which is the cardinal feature of his book, . . . the one central feature by which it is to be judged." His chief object, he says, "is to emphasize the relation of these figures to the astronomical theory, which will be entirely misunderstood unless the facts signified by these numbers are borne in mind."

What I wish to point out is that, although I have read the book more than once, I cannot find how this law is in any way connected with the general conclusions of the book.

"The cause of an Ice Age" must surely be something which is not always present and always equally efficient, but which works differently at different times, which, if operating at one time to produce an Ice Age, must either lose its effectiveness or be otherwise modified so as to permit of the existence of a temperate climate at another time.

Sir Robert Ball admits without doubt that the factor he relies upon, instead of being a variable one, is constant. He says: "The datum in our system on which the distribution depends, is the obliquity of the ecliptic"; and he goes on to say that, "amid so much that is changeable in the planetary system, it is fortunate that the obliquity of the ecliptic may for our present purpose be regarded as practically constant" (*op. cit.*, 87). He then goes on to compare the conditions which follow a small and a large eccentricity, and says: "Notwithstanding the wide difference between such a movement and that previously considered" (*i.e.* between movement in a very oblate and one in a more prolate ellipse), "it still remains true that 63 per cent. of the sun's heat is received by each hemisphere in summer, leaving only 37 per cent. for the winter" (*ib.*, 92). He again tells us that the figures 63 and 37 are independent both of the eccentricity of the orbit and of the position of the line of equinoxes; and that while the varying eccentricity created a distinction between a possible winter of 199 days and a summer of 166 days in one hemisphere, and the reversal of these same proportions in the other, that in each case the figures 63 and 37 represent the proportional quantities of heat which that hemisphere receives in summer and winter respectively" (*ib.*, 99). Lastly, speaking of the same figures, he says "they derive their importance from their constancy; they would remain the same however the dimensions of the orbit be altered, however its eccentricity be altered, or in whatever direction the plane of the earth's equator may intersect the plane of the earth's revolution around the sun." "These numbers are both functions of but a single element, which is the obliquity of the ecliptic. As this fluctuates but little, at least within the periods that are required for recent Ice Ages, the numbers we have given are regarded as sensibly constant throughout every phase through which the earth's orbit has passed within Glacial times" (*ib.*, 121):

These statements are explicit enough, and they show that the factor upon which Sir R. Ball relies is a constant factor, and being constant under all circumstances it cannot be the cause of an Ice Age. Whatever potency it has is being exerted now as much as it would be then. If it were an efficient cause of an Ice Age, we ought to be passing through one now. This argument seems to me to be complete and conclusive, and, if so, I cannot see how Sir R. Ball has done anything at all to solve the problem; for, putting this factor aside, we are remitted back to the conditions present to

Croll and others, which have been so completely shown to be inadequate to produce an Ice Age. As I am writing a big book in which I am attacking what I deem to be the extravagant and fantastic views of an influential school of geologists in regard to the so-called Ice Age, I naturally looked forward to Sir R. Ball's book with interest, and have read it with care, but I cannot see how it advances the solution of the problem, or how its position can be maintained.

HENRY H. HOWORTH.

House of Commons, February 13.

### The University of London.

MR. THISELTON-DYER, in his recent discussion of the London University question (p. 392), makes one statement which seems to me open to criticism:—

The statement is that the Colleges of the English Universities have "intrusted the business of sampling their goods to those who had nothing to do with their manufacture." Of the internal mechanism of the University of Oxford I know nothing; but I do know that in Cambridge the tendency is, and has been for the last ten years, in the direction of the reconstruction of that "teacher-examiner system" which Mr. Thiselton-Dyer believes to have been given up. The higher teaching in Cambridge is falling more and more completely into the hands of three classes of men, namely:—

(1) Professors, appointed by the University, and imposed by the University upon the Colleges, so that in each College there is at least one person who is a member of the body simply by virtue of his University office. In this way at least one subject is represented in every College by a University officer.

(2) University Readers and Lecturers, who give systematic instruction to all members of the University, without distinction of College. As these men are on the one hand appointed by the University, and are on the other hand, as a rule, members of various Colleges, they establish a further bond of union between the Colleges and the University.

(3) College Lecturers, who are now in the habit of throwing open their lectures to members of Colleges other than their own, and who are frequently members of the University Boards of Studies.

In this way the higher teaching is being thrown more and more completely into the hands of men who are under the direct control of the University itself; and a study of the current Calendar shows that the task of examining students is intrusted largely to these very men. Of the examiners for the various Triposes (of whom there are about eighty), at least fifty-six belong to one of the three categories above mentioned. Those examiners who are non-resident, or who are not engaged in teaching, act as a rule in conjunction with colleagues who are actual teachers, so that there is no single Tripos in which a student is not fairly certain to be "sampled" (to use Mr. Thiselton-Dyer's phrase) by a man who has had a great deal to do with his "manufacture."

This is almost precisely the "teacher-examiner system" to which Mr. Thiselton-Dyer refers; and the steady growth of this system in Cambridge is a certain proof that it is not incompatible with the development of the highest type of University in England.

W. F. R. WELDON.  
University College, London, February 27.

### The Aneroid in Hypsometry.

FROM a review under this title in NATURE of the 11th ult. (p. 339) it appears that Mr. Whympy has done good service to those who use the aneroid in measuring heights, by pointing out a very serious source of error in this instrument. According to the reviewer:—"All who have had any experience in testing aneroids in the usual way, viz. by subjecting them to gradually reduced pressures under the air-pump, and comparing their readings with the concomitant indications of the manometer, are aware that the variations of the two instruments with falling and then with increasing pressures are by no means concordant; but it will be probably new to most that, when the aneroid is allowed to remain for some weeks under the reduced pressure, its indications continue falling, and to such an extent that its final error in certain cases is five or six times as great as when the exhaustion was first completed. On the other hand, aneroids that have been kept for some weeks at a low pressure when restored to the full pressure of the atmosphere take many weeks to regain

their condition of equilibrium. The greater part of the recovery takes place in the first week, and a considerable part in the course of the first day."

Now I have little doubt that both the want of accordance in the readings of the instrument with decreasing and then with increasing pressure, and the "after-working" mentioned above, are mainly, if not entirely, due to the imperfect elasticity of the corrugated disk that forms the cover of the exhausted chamber. No metal is perfectly elastic except with very minute stresses, and, as a consequence, when a metal is made to go through a complete stress cycle, there is always more or less lagging of strain behind stress. Again, there is with all metals more or less of *time-lag*, so that any alteration of stress does not produce its full effect all at once. Provided the temperature be kept constant, and the metal be not in any way disturbed, the *time-lag* is of such a nature that for equal successive intervals of time the corresponding changes of strain form a descending geometrical progression. With some metals, such as tempered steel, and with moderate stresses, the effects of imperfect elasticity are not of any material consequence. With others, however, such as aluminium and zinc, and the alloys of the latter metal—namely, brass, *German-silver*, &c.—we meet with very appreciable deviations from the laws of perfect elasticity, even when the stresses used do not produce any permanent deformation. I understand that the corrugated cover is frequently made of an alloy something like German-silver, only softer. If this be so, I can well believe, from my experience of this alloy, that grave errors might arise, and probably have arisen, in the determinations of heights by the aneroid. If such a thing be feasible, I would suggest that the cover should be made of tempered steel.

HERBERT TOMLINSON.

King's College, Strand, February 19.

#### Sparrows and Crocuses.

THE time of year has arrived when we shall once more be hearing of the ravages of sparrows on crocus blooms, and the theories advanced in order to account for this propensity for destruction on the part of the sparrow in suburban gardens and elsewhere. One pet theory is that the sparrow has a fondness for *yellow*, and shows it by destroying crocuses of that colour. Most unfortunately for the holders of such an opinion, the sparrow does not confine its attentions to yellow crocuses only, but attacks also the purple, white, &c., as any grower of crocuses can prove. Undoubtedly the yellow suffer most, probably because they are the first to appear, and meet the birds' most pressing requirements. Moreover, the sparrows sometimes attack the flowers while still in the sheath, and before it is certain what colour they will be.

The object of the sparrow in destroying the flowers is simply to obtain *succulent food* at a time of year when such in the form of larvae, &c., is scarce. I have repeatedly watched the operation from my study window at a distance of very few feet. The stalk of the flower is bitten off by the bird some little distance below the flower itself. The succulent stalk is then nibbled away until the flower falls to pieces. The reproductive parts, and especially the anthers are not attacked, as some writers have asserted; but in consequence of the structure of the flower, they, like the petals and sepals, often fall away owing to the close nibbling of the bird.

Primroses also suffer. Early primroses are usually the common *yellow form*, *ergo*, according to theory-makers, the same cause is at work. So it is, but not in the direction they would have us believe. Here, again, I have distinctly seen the birds eating the flower-stalk.

I had written you a letter to the same effect as this about the same time last year, but from some cause or other it was not forwarded. I take this opportunity of possibly anticipating other letters on the same subject, and of inducing theorists to carefully watch the *modus operandi* as I have done before rushing into print.

R. MCLACHLAN.

Lewisham, February 26.

#### A Possible Misunderstanding.

I HAVE seen a report that, in a recent number of the *Atti della Regia Accademia delle Scienze di Torino*, Prof. Galileo Ferraris is credited with a statement which might mean that one of the formulæ which appear in a paper read by me before the Physical Society of London, in May 1888, was derived from a

paper by him. If that be Signor Ferraris's meaning, he is entirely mistaken. My formulæ were obtained quite independently of Signor Ferraris or of anyone else.

THOMAS H. BLAKESLEY.

Royal Naval College, February 29.

#### HERMANN KOPP.

HERMANN FRANZ MORITZ KOPP, a distinguished German chemist, and one of that band of literary and scientific workers which, five-and-twenty years ago, made Heidelberg celebrated as a centre of intellectual activity, passed away from the scene of his labours on February 20, in the seventy-fifth year of his age. He had been in failing health for some time past, and although his recuperative power at times seemed wonderful, his friends were not wholly unprepared for his decease.

Born October 30, 1817, at Hanau, where his father, Johann Heinrich Kopp, practised as a physician, Hermann Kopp received his school training at the Gymnasium of his native town, and thence passed to the Universities of Heidelberg and Marburg with the object of studying the natural sciences, and more particularly chemistry. The special bent of his mind towards chemistry would seem to have been given by his father. The elder Kopp occasionally busied himself with experimental chemistry, and Leonhard's *Taschenbuch* and Gehlen's *Journal* contain papers by him on mineral analyses and on investigations relating to physiological chemical products.

In 1839, Hermann Kopp joined Liebig at Giessen, drawn thither by the extraordinary influence which has made the little laboratory on the banks of the Lahn for ever famous in the history of chemical science. For nearly a quarter of a century Kopp found in Giessen full scope for his scientific and literary activity. In 1841 he became a *privat-docent* in the University, two years later he was made an extraordinary professor, and in 1853 he became ordinary professor. In 1864 he was called to Heidelberg, where he remained until his death, occupying himself latterly with lectures on the history of chemistry, and on chemical crystallography.

At the very outset of his career as an investigator, Kopp seems to have devoted himself to that field of inquiry in which his chief distinction as an original worker was won, viz. physical chemistry. One of his earliest papers—"Ueber die Vorausbestimmung des specifischen Gewichts einiger Klassen chemischer Verbindungen," published in *Poggendorff's Annalen* in the year he went to Giessen—deals with the conception of *specific volume*, which he here introduces for the first time. During the ensuing five-and-twenty years, so far as laboratory work was concerned, he was almost entirely occupied in attempting to trace experimentally the connection between the physical properties of substances and their chemical nature. We owe to Kopp, in fact, all our broad fundamental generalizations concerning the connection between the molecular weights, relative densities, boiling-points, and specific heats of substances, and on the relations of crystalline form and chemical constitution to specific volume. For work of this kind Kopp was eminently well fitted. To remarkable manipulative dexterity and great ingenuity—much of which, as in the case of Wollaston, was spent in satisfying a certain fastidiousness for simplicity of apparatus and experimental method—was joined the most scrupulous sense of accuracy and illimitable patience. As proof of his accuracy, it may be stated that, although many observers have had occasion, from time to time, to review his work on the thermal expansion of liquids—and on a far more ambitious scale, and with more refined apparatus, than was possible half a century ago—his determinations have been practically unchallenged, and retain their place among the best ascertained constants of their kind.

Kopp's scientific papers dealing with his laboratory labours mainly appeared in *Poggendorff's Annalen der Physik und Chemie*, and latterly in *Liebig's Annalen der Chemie*. One or two of his contributions appeared in the *Philosophical Magazine*, and the Chemical Society published his elaborate memoir on the specific heats of compound substances, in which he sought to develop and extend Naumann's law. But, compared with those of his contemporaries, Liebig and Wöhler, his papers are comparatively few in number. This is largely accounted for by the very character of his investigations. His communications were, for the most part, records of measurement, often troublesome and tedious in their nature, and followed by long and wearisome calculations; and in many cases the substances with which he experimented could only be prepared in a state of purity by long-continued operations. It is only those who have engaged in work of this kind that can properly appreciate the amount of labour thus involved. The nature of the relations which he strove to elucidate necessitated the determination of the particular physical constants of some scores of substances; indeed, to Kopp, their number was only limited by the extent of his knowledge of the existence of their isomerides and homologues. Much of this work was necessarily of a pioneer character. It stands, in fact, to our later knowledge much in the same way as does the work of Boyle, Mariotte, and Gay-Lussac to the fuller development of the gaseous laws which we have witnessed during the past few years. Kopp, indeed, was among the earliest to venture into a province of which he actually was the first to recognize the exceeding fruitfulness. Its soil, however, is not of that nature which, tickled with a hoe, laughs with a harvest; it is only with much tillage and patient toil—the conjoint work of physicists and chemists—that it can be made to yield its riches. It is, however, by such work that the supreme secret—the true nature of the form of force with which the chemist is mainly concerned, the real nature of chemical affinity—will be revealed.

Kopp is known to the literary world mainly by his great work on the "History of Chemistry" (Brunswick, 1843-47, 4 vols.). The amount of labour and research involved in the preparation of this work was simply stupendous. It is not many men of twenty-five who would have either the skill or the patience to attack the mass of literature which embalms the chemical lore of the ancient peoples of the East, or who would devote years to extracting what there is of science or philosophy from the jargon of the alchemists, or the mystical writings of the Rosicrucians. It is hardly to be wondered at that nearly every subsequent writer on the history of chemistry has been content to take his facts from Kopp: their works, so far as they relate to the early history of the science, are based, and, for the most part, avowedly so, on his researches. From time to time Kopp published supplementary volumes on the same subject. In 1869-75 appeared his "Beiträge zur Geschichte der Chemie" (Brunswick, three parts); in 1871-73 the "Entwicklung der Chemie in neuerer Zeit"; and, in 1886, "Die Alchemie in älterer und neuerer Zeit" (Heidelberg, 2 vols.). In 1849 appeared his "Einleitung in die Kristallographie" (Brunswick; 2nd ed., 1862); and in conjunction with his Giessen colleagues, Buff and Zamminer, he published his "Lehrbuch der physikal. und theoretischen Chemie" (Brunswick, 1857; 2nd ed., 1863), which constitutes a portion of the well-known Graham-Otto's "Lehrbuch der Chemie," one of the standard text-books in Germany and Austria.

In 1848, Kopp joined Liebig in the production of the *Jahresbericht über die Fortschritte der Chemie*, which he continued to edit, latterly with Heinrich Will, down to 1862. In 1851 he became the acting editor of the *Annalen der Chemie*, and although, with increasing years and failing health, he was obliged to relinquish the re-

sponsible management, he continued to the last to take a lively interest in the fortunes of the periodical.

Kopp's services to chemical science were recognized by our own Chemical Society as far back as 1849; and, with the exceptions of Bunsen, who is the *Doyen* of the *Forty*, and who celebrates his jubilee as a Foreign Member this year, and of Fresenius, who was elected in 1844, he was the oldest Foreign Member of the Society. He was made an honorary member of the German Chemical Society in 1869, and in 1888 he was elected a Foreign Member of the Royal Society.

Kopp was a good linguist and an omnivorous reader, not only of matters scientific, but also of history and contemporary politics. He was remarkably catholic in his tastes and wide in his sympathies. Indeed, no man could be further removed than he in this respect from the conventional idea of the German professor. He was a constant reader of *NATURE*, and hence was well informed of the march of events, scientific and educational, in this country. The writer of this notice, who counts it a great privilege to be able to number himself among his pupils, when visiting him in Heidelberg last spring was astonished to find how fully and accurately he had grasped the details and bearings of the projected scheme for the new University in London, as it was at that time understood. He was much interested, too, in the great experiment which the County Councils have undertaken in relation to secondary education, but of the result of that experiment in its present form he expressed himself as not very hopeful. His extraordinary range of information, his wonderfully retentive memory, his geniality, his keen sense of humour, his fund of anecdote, and exceptional conversational powers, made him one of the most delightful of companions. Even in the pages of the *Jahresbericht*, the evidences of Kopp's humour are to be found. In abstracting the well-known paper by Playfair and Joule on the Specific Volume of Hydrated Salts, he is constrained to remark:—

"Die Verfasser dieser Abhandlung sind anerkannt Forscher, aber das hebt die Unbegreiflichkeit nicht auf, dass in dem phosphorsauren Natron, welches wir vor uns sehen, es nur das Wasser sein soll, welches den Raum erfüllt, *neither acid nor base occupy space*. Wie durch Zauberei kommen die letztern erst bei dem Erhitzen räumlich zum Vorschein.—Säure und Basis nehmen hier keinen Raum ein, *weil* die Annahme, das Wasser sei hier mit dem spec. Volum des Eises vorhanden, gemacht worden ist, und nach ihr für Säure und Basis Nichts übrig bleibt. Jene Katze wurde von ihrem Herrn vermisst, obgleich er sie unter Händen hielt, *weil* er die Annahme gemacht hatte, sie habe das Fleisch gefressen. An diese merkwürdige Begebenheit wird man sehr oft in den Naturwissenschaften erinnert. Ein Mann supponirte, seine Katze habe Fleisch gefressen; er wog sie, und da sie grade so viel wog als das abhandene gekommene Fleisch, sagte er verwundert: 'hier ist mein Fleisch; wo bleibt meine Katze?'"

As Mr. Oscar Wilde has just reminded us, we are far too serious nowadays; our *Jahresberichte*, *Berichte*, and Chemical Society Journals have grown to be fat, unwieldy tomes, and the printers' bills grow steadily year by year; otherwise some of us would not be greatly shocked to find our scientific reading occasionally lightened a little in this way. For it was the saying of an ancient sage that humour is the only test of gravity; and gravity, of humour.

By no one will Kopp's departure be more keenly felt than by Bunsen, his friend and colleague for more than a quarter of a century. The strollers along the Anlage will miss the quaint little figure on its way to the daily visit to the old veteran, who, rich in honour and in years, is now the last of that famous triumvirate—Bunsen, Kirchhoff, and Kopp—the memory of whose services the world will not willingly let die.

T. E. THORPE.

## NOTES.

THE annual *soirée* of the Royal Society is to be held on Wednesday, May 4. There will be a ladies' *conversazione* later in the season.

ON Monday Mr. Balfour announced that the draft charter of the Gresham University would be remitted for reconsideration; and promised to make a statement on the subject this evening. The proposal to refer the charter back to the Privy Council has caused much dissatisfaction. The only reasonable course is to refer it to a Committee, on which educationalists and teachers in all the faculties shall be strongly represented.

AT the ordinary meeting of the Royal Meteorological Society, to be held at 25 Great George Street, Westminster, on Wednesday, the 16th instant, at 7 p.m., the President, Dr. C. Theodore Williams, will deliver an address on "The Value of Meteorological Instruments in the selection of Health Resorts," which will be illustrated by a number of lantern slides. The meeting will be adjourned at 8.30 p.m., in order to afford the Fellows and their friends an opportunity of inspecting the Exhibition of instruments, charts, maps and photographs relating to climatology, and of such new instruments as have been invented or first constructed since the last Exhibition. The Exhibition will be open from Tuesday, the 15th instant, to Friday, the 18th.

STILL another new chemical laboratory in Germany. We hear that Prof. Emil Fischer, at Würzburg, is now to have a new laboratory at a cost of 600,000 marks. Prof. Victor Meyer's new laboratory at Heidelberg is to be ready on May 1.

WE regret to have to record the death of Sir John Coode, the eminent engineer. He died on March 2 at the age of seventy-six. He was President of the Institution of Civil Engineers in 1889 and 1890.

IN connection with the International Congresses of Zoology and Prehistoric Archæology, which will be held this summer at Moscow, an exhibition of acclimatization will be opened at the end of June. It will contain specimens of all plants acclimatized in Russia.

THE office of Superintendent-General of Education for Cape Colony, rendered vacant by the retirement of Sir Langham Dale, has now been filled, Dr. Thomas Muir, of the High School of Glasgow, to whom it was offered some time ago, having definitely accepted the appointment. The *Glasgow Herald* speaks of Dr. Muir's departure as "a distinct loss to education and science in Scotland." Some years ago the Royal Society of Edinburgh awarded to him the Keith Medal for his contributions to mathematics.

AN important memorial will shortly be brought before the Board of the Faculty of Natural Science, Oxford, by the Council of the Association for the Improvement of Geometrical Teaching. It relates to what the Council regard as a serious defect in the Oxford Pass Examination papers in geometry. These generally consist entirely of propositions enunciated without any variation from the ordinary text of Euclid, and scarcely any attempt is made to discover whether a student's answers are other than the outcome of a mere effort of memory. The Council are of opinion that such papers have the effect of a direct incentive to unintelligent teaching, and respectfully ask for the introduction of simple exercises and of simple questions on the book-work set in order to promote the rational study of geometry.

THE relics of the explorers John and Sebastian Cabot, preserved at Bristol, are to be sent to the Chicago Exhibition. It is expected that they will attract much attention.

IN the electricity building at the Chicago Exhibition there will be no fewer than 40,000 panes of glass. This building will be especially conspicuous at night, as, owing to its extensive glass

surface, the brilliancy of its electrical exhibit will be strikingly visible from the outside.

LAST Saturday Prof. Roberts-Austen delivered one of the series of lectures now being given at the South Kensington Museum for the purpose of extending the knowledge of the science and art collections and of making them more generally useful, taking as his subject art metal-work. He pointed out that, as a metallurgist, he could only claim authority to deal with the materials employed for art metal-work. Setting aside wrought iron, the most important of these were alloys, especially those of the copper-tin series (the bronzes), and those of the copper-zinc series (the brasses). When the elder Pliny wrote in the first half of the first century of our era, and described the nature of the early metallurgy, industrial art in bronze was really far advanced. The artist, however, had in point of skill left the metallurgist far behind. Referring to the presence of lead in bronze as giving to the metal a beautiful velvety *patina* by atmospheric exposure, Prof. Roberts-Austen said that there was little use in attempting to compose a bronze with a view to enable it to acquire a *patina* in the London atmosphere. He took as an instance one of our last erected monuments, the equestrian statue of Lord Napier of Magdala opposite the Guards' Memorial in Waterloo Place. A few weeks ago the *patina* had begun to form, and iridescent tints played over the features, while unsightly rain stains ran down his horse; now the layer was thickening, and a gray-brown tint deepening, but there was no velvety-brown oxide, or rich green and blue carbonate. The soldier, field-glass in hand, was sternly looking away from the Athenæum and the learned Societies, as if conscious that, in the present state of the London atmosphere, he was beyond the aid of science, for science had clearly stated that so long as bituminous coal was burnt in open fire-places London must be smoky, and man and horse would soon be covered with a black pall of soot and sulphide of copper, such as now enshrouded the unfortunate occupants of the adjoining pedestals.

THE Royal Society of New South Wales offers its medal and £25 for the best communication (provided it be of sufficient merit) containing the results of original research or observation upon each of the following subjects:—To be sent in not later than May 1, 1892: on the iron ore deposits of New South Wales; on the effect which settlement in Australia has produced upon indigenous vegetation, especially the depasturing of sheep and cattle; on the coals and coal measures of Australia. To be sent in not later than May 1, 1893: upon the weapons, utensils, and manufactures of the aborigines of Australia and Tasmania; on the effect of the Australian climate upon the physical development of the Australian-born population; on the injuries occasioned by insect pests upon introduced trees. To be sent in not later than May 1, 1894: on the timbers of New South Wales, with special reference to their fitness for use in construction, manufactures, and other similar purposes; on the raised sea-beaches and kitchen middens on the coast of New South Wales; on the aboriginal rock carvings and paintings in New South Wales. The competition is not confined to members of the Society, nor to residents in Australia, but is open to all without any restriction whatever, excepting that a prize will not be awarded to a member of the Council for the time being; neither will an award be made for a mere compilation, however meritorious in its way. The communication, to be successful, must be either wholly or in part the result of original observation or research on the part of the contributor. The successful papers will be published in the Society's annual volume. Fifty reprint copies will be furnished to the author free of expense.

A PRIZE is offered by Schnyder von Wartensee's Foundation, Zürich, for the solution of the following problems in the domain of physics. "As the numbers which represent the atomic heats of

the elements still show very considerable divergences, the researches conducted by Prof. H. F. Weber on boron, silicium, and carbon, regarding the dependence of the specific heats upon the temperature, are to be extended to several other elements, prepared as pure as possible, and also to combinations or alloys of them. Further, the densities and the thermic coefficients of expansion of the substances investigated are to be ascertained as carefully as possible." The following are the conditions: the treatises handed in by competitors may be in German, French, or English, and must be sent in by September 30, 1894. The examination of the treatises will be intrusted to a Committee consisting of the following gentlemen: Prof. Pernet, Zürich; Prof. A. Hantzsch, Zürich; Prof. E. Dorn, Halle-on-the-Saale; Prof. J. Wislicenus, Leipzig; Prof. E. Schär, Zürich, as member of the Committee offering the prizes. The Prize Committee is empowered to award a first prize of two thousand francs, and minor prizes at its discretion to the amount of one thousand francs. The work to which the first prize is awarded is to be the property of Schnyder von Wartensee's Foundation, and arrangements will be made with the author regarding its publication. Every treatise sent in must have a motto on the title-page, and be accompanied with a sealed envelope bearing the same motto outside and containing the author's name. The treatises are to be sent to the following address: "An das Praesidium des Conventes der Stadtbibliothek, Zürich (betreffend Preisaufgabe der Stiftung von Schnyder von Wartensee für das Jahr 1894)."

At the meeting, on February 17, of the Russian Geographical Society, the Constantine Medal was awarded to M. V. Pyetsoff for his work of exploration in Central Asia, especially during the last Tibet expedition. The Count Lütke Medal was awarded to A. I. Vilkitsky for his measurements of pendulum oscillations in Russia. A newly established prize, consisting of the interest on a sum collected by public subscription after the death of Prjevalsky, was granted to G. E. Grum-Grzmailo for his researches in Central Asia in 1889-90, and large silver medals, also associated with Prjevalsky's name, were awarded to the companions of his expeditions, V. I. Soborovsky and P. K. Kozloff, to the geologist of the last Tibet expedition, K. I. Bogdanovitch, for his geological work in Central Asia, and to M. E. Grum-Grzmailo for the surveys he made in company with his brother in the Pamir. The great Gold Medal of the Society was awarded by the Section of Ethnography to A. N. Pypin, for his "History of Russian Ethnography," and by the Section of Statistics to A. A. Kaufmann for his researches on the economical conditions of the peasants and indigenes in the Ishim and Tura districts of West Siberia. Four small gold medals and seventeen silver ones were awarded for works of less importance.

At the same meeting the yearly report of the Society was read, and we learn from it that the Expedition which has been sent out for the exploration of the Chinese province Sy-chuang, and the territory on the slopes of the Tibet plateau, will soon start from Peking. The leader of the Expedition, the zoologist M. V. Berezovsky, is already in Peking, preparing to start on his journey. N. F. Katanoff is hard at work collecting ethnographical materials in Mongolia. K. P. Sternberg continued his pendulum observations in South Russia and Crimea; and A. E. Radd continued to investigate the magnetic anomalies about Byelgorod, in Kursk. L. I. Lutughin has made geological explorations and levellings on the watershed between the Volga and the Northern Dvina; while the Ministry of the Navy has continued this year the exploration of the Black Sea. In the department of ethnography, the report mentions the work of E. R. Romanoff in White Russia, and MM. G. E. Vereschagin and Shilkoff among the Votyaks. The East Siberian branch of the Society has accomplished, as usual, a good deal of

useful work. Prof. Koizynski has explored the Amur region, with especial reference to the advantages it offers for culture and colonization: V. A. Obrutcheff continued the exploration of the Olekma and Vitim highlands; MM. Yadrintseff, Klementz, and Levin took part in Prof. Radloff's expedition to the valley of the Orkhon in Mongolia; and Dr. Kirilloff continued his studies of Mongolian medicine. The Museum at Irkutsk has been enlarged, and further enriched by new collections. The publications of the Society included: the work of the Novaya Zemlya Polar Station; the ornithology of North-west Mongolia, by MM. Berezovsky and Bianchi; several volumes of Memoirs; and the Bulletin (*Izvestia*). The new monthly periodical, meteorological *Vyestnik*, and the "Living Antiquity" (*Zhivaya Starina*) have been issued regularly during the past year.

WE are glad to be able to report an advance in the Meteorological Service of Roumania. For some years the official publication of that country has been limited to the yearly volume containing the observations for Bucharest. From January 1 last, however, the Meteorological Institute has begun the issue of a monthly bulletin containing observations taken three times daily at Soulina, Bucharest, and Sinaia, 6 feet, 269 feet, and 2821 feet above the sea, respectively. The various weather phenomena are represented by the symbols adopted for international meteorological publications.

THE Danish Meteorological Institute and the Deutsche Seewarte, conjointly, have recently issued daily synoptic weather charts, for the North Atlantic Ocean and adjacent continents, for the year ending November 1887, completing the series from September 1873, with the exception of the following dates: December 1876 to November 1880, being the period which elapsed from the death of Captain N. Hoffmeyer, who commenced the work, to its resumption by the two above-named institutions; and September 1882 to August 1883, being the period for which the Meteorological Office published its elaborate synchronous charts for the same area. For three years ending November 1886, the Deutsche Seewarte has published a separate text explanatory of the general conditions of weather for the area embraced by the charts, and showing the effect of the conditions upon the navigation of vessels, together with charts, selected for various periods of special interest, showing the position and movements of barometrical maxima and minima. The work furnishes the best possible materials for studying the connection between the weather of the Atlantic and that of our islands.

OBSERVATIONS of air-pressure during a total solar eclipse reveal an influence of the latter phenomenon on the former. In a recent number of the *Annalen der Hydrographie*, Herr Steen studies the eclipse of August 29, 1886, in this respect, using the records (at intervals of a quarter of an hour) of fourteen Norwegian ships between Panama and Madagascar, of which four were in the zone of totality, and at least four others quite close to it. Having first eliminated the daily period of air-pressure, he groups the observations of the ships, and forms means; and he finds both these and the individual records reveal two maxima of air-pressure, separated by a minimum. In the totality zone the first maximum is 35m., and the second 2h. 15m., after the middle of the eclipse; in the partial zone, the first is 25m. before, and the second 1h. 40m. after, the middle. This double wave, Herr Steen explains thus. During a solar eclipse, day is changed to night for a short time, and the transition is much like the ordinary change from day to night in the tropics, where the twilight is but short. There the curve of air-pressure has regularly a maximum about 10 p.m., some time after sunset, and a minimum about 4 a.m., shortly before sunrise; while a second maximum appears about 10 a.m. It is natural a total solar eclipse should act similarly. The displacement of the "epochs" of the air-pressure wave in the partial

none as compared with the zone of totality is more difficult to account for.

THE Smithsonian Institution has printed a capital study of the puma or American lion (*Felis concolor* of Linnæus), by Mr. F. W. True. The author notes that the puma possesses in a remarkable degree the power of adapting himself to varied surroundings. The animal endures severe cold during the winter in the Adirondack Mountains and other parts of the northern frontier of the United States, and tracks his prey in the snow. He is equally at home in the hot swamps and canebrakes along the river-courses of the Southern States. In South America he inhabits the treeless, grass-covered pampas as well as the forests. In the Rocky Mountains, as Mr. True is informed by Mr. William T. Hornaday, he ascends to the high altitudes in which the mountain sheep are found. Mr. Livingston Stone saw tracks of the puma on the summit of Mount Persephone in California, at an elevation of 3000 feet. Similarly, Darwin states that he saw the footprints of the puma on the Cordillera of Central Chili, at an elevation of at least 10,000 feet. According to Tschudi, the puma is found in Peru in the highest forests and even to the snow-line.

In his Report on the Royal Botanic Gardens, Trinidad, for 1890, just issued, Mr. J. H. Hart, the Superintendent, says that, while on a journey to St. Vincent, in August 1890, he discovered a form of *Agave rigida*, Mill., previously unknown to West Indian florists. It produces a useful fibre, but appears to be too short in the leaf to rival the variety known as *Agave rigida*, var. *sisalana*, of Perrine. The same species has also since been found in Barbados, and identified with the above. "With nothing," says Mr. Hart, "is it more easy to make a mistake than the various species of *Agave*, and special care should be taken by growers for economical purposes to have their plant identified by competent persons, before expending large sums on cultivation. As an instance, I may mention that the *Coratœ* of Jamaica was for long years popularly supposed to be no other than the Tropical American *Agave americana*, until an examination was made into its characteristics by Mr. D. Morris when that gentleman was resident in Jamaica. The same thing occurred in Trinidad. The *Langue Banf* of the Bocas Islands was for many years supposed to be *Agave vivipara*, Linn., but a plant sent to Kew from these Gardens proves it to be the Mexican *Agave polyacantha*, Haw. A plant from St. Lucia, recently received, shows characteristic points differing from any of the above, though popularly supposed to be identical with our Bocas Island plant, and it may be found that several unknown *Agaves* exist in the West Indies that have been passed over by botanists from their similarity of growth to the commonly known forms of the larger islands and mainland."

AN excellent series of "Museum Hand-books" is being issued by the Manchester Museum, Owens College. A "General Guide to the Contents of the Museum" has been prepared by Mr. W. E. Hoyle, Keeper of the Museum, and Prof. Milnes Marshall has drawn up an "Outline Classification of the Animal Kingdom," and a "Descriptive Catalogue of the Embryological Models."

WE have received the tenth Annual Report of the U.S. Geological Survey to the Secretary of the Interior, 1888-89, by Mr. J. W. Powell, Director. It is divided into two parts, the first relating to geology, the second to irrigation.

MESSEURS GAUTHIER-VILLARS have published a work entitled "Leçons de Chimie," by Henri Gautier and Georges Charpy. It is intended mainly for the use of students of special mathematics.

WE learn from the *Journal of Botany* that the first part will shortly be issued by Messrs. Dulau and Co. of a new botanical

publication, to be called *British Museum Phycological Memoirs*, edited by Mr. George Murray. It will be devoted exclusively to original algalogical papers, the records of research carried on in the Cryptogamic laboratory of the British Museum in Cromwell Road, and is intended to be issued at about half-yearly intervals. The first part will be illustrated by eight plates, and will contain, among other articles, the description of a new order of Marine Algae.

DR. BAILLON'S "Dictionnaire de Botanique," the publication of which was commenced in 1869, is now completed.

A NEW acid, chromosulphuric, possessing the composition  $H_2Cr_2(SO_4)_4$ , is described by M. Recoura in the current number of the *Comptes rendus*. A short time ago the same chemist obtained a remarkable isomeric form of chromic sulphate  $Cr_2(SO_4)_3$ , which exhibited neither the reactions of a sulphate nor of a salt of chromium. For instance, its solution yielded no precipitate of barium sulphate with barium chloride. This isomeric form of chromic sulphate is found to combine directly with one equivalent of sulphuric acid or of a metallic sulphate to produce the new acid, or a salt of it. Thus, when a solution of zinc sulphate is mixed with a solution of the isomeric sulphate of chromium in equivalent molecular proportion, zinc chromosulphate is formed,  $ZnCr_2(SO_4)_4$ . The solution of this zinc salt so obtained gives none of the reactions of sulphuric acid, nor does it yield those of chromic acid, but it exhibits the usual reactions of zinc salts; hence it must be a zinc salt of a specific acid, chromosulphuric. When the solutions of the new acid and its salts are allowed to stand, they gradually decompose, and barium chloride commences to precipitate barium sulphate, hence they appear not to be very stable, but to decompose slowly into a mixture of ordinary chromic sulphate and sulphuric acid or the metallic sulphate. Boiling brings about the decomposition at once. The acid itself has been obtained in the solid state, combined with eleven molecules of water; it is a green powder, which is very hygroscopic, and rapidly deliquesces in moist air but is quite permanent in a dry atmosphere. Its solution possesses a brilliant green colour when freshly prepared, but, upon standing, changes to blue, and, after a few days, passes completely into a violet-coloured solution of ordinary chromic sulphate mixed with free sulphuric acid. The potassium salt has also been obtained in the solid state, combined with four molecules of water, as a green powder whose dilute solution yields no precipitate with barium chloride, but at once gives the usual potassium precipitates with platinum chloride and picric acid. This salt also appears to be formed when chrome alum is dehydrated first for some time at 90°, and finally at 110°. The sodium and ammonium salts have likewise been obtained, and are found to resemble the potassium salt closely in their nature and properties.

THE additions to the Zoological Society's Gardens during the past week include two Silver-backed Foxes (*Canis chama*), two Leopard Tortoises (*Testudo pardalis*) from South Africa, presented by Mr. C. Holmes; a Vulpine Phalanger (*Phalangerista vulpina* ♂) from Australia, presented by Mr. W. J. C. P. Macey; a Ring-tailed Coati (*Nasua rufa*) from South America, presented by Miss M. Tew; a Fallow Deer (*Dama vulgaris* ♀), British, presented by Mrs. Edith Hilder; a Milky Eagle Owl (*Bubo lacteus*) from Mashonaland, South Africa, presented by Mr. E. A. Maund; four Herring Gulls (*Larus argentatus*), a Lesser Black-backed Gull (*Larus fuscus*), two Black-headed Gulls (*Larus ridibundus*), a Jackdaw (*Corvus monedula*), a Tawny Owl (*Syrnium aluco*), British, an Orange-checked Max-bill (*Estrela melopoda*) from South Africa, two Hooded Finches (*Spermestes cucullata*) from West Africa, an Indian Silver-bill (*Munia malabarica*) from India, twelve Barbary Turtle Doves (*Turtur risorius*) from North Africa, presented by Mrs. Kate

Taylor; a Sharp-nosed Crocodile (*Crocodilus acutus*) from Havana, presented by Mr. Arthur Morris; a Chimpanzee (*Anthropopithecus troglodytes* ♂) from West Africa, a Bison (*Bison americanus* ♂) from North America, an Anaconda (*Eumeces murinus*) from South America, deposited; a Brazilian Tapir (*Tapirus americanus* ♀) from South America, four Hairy-rumped Agoutis (*Dasyprocta prymnolopha*) from Guiana, a Mexican Agouti (*Dasyprocta mexicana*) from Mexico, four Scarlet Ibises (*Eudocimus ruber*) from Para, a Blue and Black Tanager (*Tanagraella cyanomelana*) from South-East Brazil, a Prince Albert's Curassow (*Crax alberti* ♀) from Columbia, purchased.

#### OUR ASTRONOMICAL COLUMN.

CORDOVA OBSERVATORY.—A publication of some importance has recently been issued from the Observatorio Nacional Argentino. It contains the observations made under the direction of Dr. Gould, in 1880, for the General Catalogue, arranged and published by Mr. J. M. Thome, the present Director of the Observatory. The mean places of 10,923 stars have been found from 33,837 separate and complete determinations, and this during one year of observation. In addition, 1613 observations of circumpolars, and 1738 of time-stars, have been made for determining instrumental corrections. It is therefore well remarked that "the dimensions of the volume almost entitle it to the rank of a General Catalogue, and the results for the month of December alone, when 5938 determinations of positions were made, would form a fair Annual Catalogue." In order to get through this immense amount of work, the meridian circle was manned with an observer, a microscope reader, who also pointed the telescope, and a recorder; and on four nights of eight hours each, in December, these three observers made, on the average, 1540 complete determinations. And the work has been done in such a thorough manner, in spite of the rapidity of execution, that one cannot but admire the dexterity of Messrs. Bachmann, Davis, and Stevens, who have assisted Mr. Thome. The right ascensions are referred to the "Standard Places of Fundamental Stars," second edition, published in 1866. The mean places of these stars for the beginning of each year, to 1880 inclusive, are published in the American Ephemeris tables, and their apparent places in successive volumes. The magnitudes recorded in the Catalogue are generally the results of estimation. Stars, however, which occur in the "Uranometria Argentina" have had their magnitudes taken from the data collected for that work. Catalogues of southern stars are hardly so plentiful as those containing places of stars north of the equator. This volume is therefore doubly welcome. It represents work carried out in spite of the vicissitudes to which an Observatory in the Argentine Republic must be subject, and the results obtained will be appreciated by all.

ALGOL.—In a series of contributions to the knowledge of the variable stars, which has appeared in the *Astronomical Journal*, Dr. S. C. Chandler has discussed the periods, motions, and laws of variable stars. His last communication, contained in Nos. 255 and 256 of the *Journal*, deals with the inequalities in the period of  $\beta$  Persei; the theory which satisfactorily accounts for these and other phenomena being stated as follows:—"Algol, together with the close companion—whose revolution in 2d. 20<sup>h</sup>. produces by eclipse the observed fluctuations in light, according to the well-known hypothesis of Goodrich, confirmed by the elegant investigation of Vogel—is subject to still another orbital motion, of a quite different kind. Both have a common revolution about a third body, a large, distant, and dark companion or primary, in a period of about 130 years. The size of this orbit around the common centre of gravity is about equal to that of Uranus around the sun. The plane of the orbit is inclined about 20° to our line of vision. Algol transited the plane passing through the centre of gravity perpendicular to this line of vision in 1804 going outwards, and in 1869 coming inwards. Calling the first point the ascending node, the position-angle, reckoned in the ordinary way, is about 65°. The orbit is sensibly circular, or of very moderate eccentricity. The longest diameter of the projected ellipse, measured on the face of the sky, is about 2" 7". A necessary consequence of this theory is an irregularity of proper motion with an amplitude of something over a fifth of a time-second in right ascension, and nearly one and a half seconds in declination; the middle point being

the centre of gravity of Algol, and the distant unknown companion, and the uniform proper motion of the latter being  $-0\cdot00108$ , and  $+0\cdot0\cdot0120$  annually, in the two co-ordinates respectively. The annual parallax of the star is about 0" 07. The mean period of light variation is 2d. 20<sup>h</sup>. 45<sup>m</sup>. 56<sup>sec</sup>." It seems very probable, from Dr. Chandler's communication, that the inequalities in the periods of other variables of the Algol type will admit of a similar explanation.

THE SUN-SPOTS OF FEBRUARY.—Some facts with regard to the dimensions of the recent sun-spots appear in the March number of the *Observatory*. The group of spots apparently connected with the great magnetic disturbance of February 13-14, and the aurora which was visible at a large number of places on the latter date, was first seen on the east limb of the sun on February 5. It passed the central meridian six days later, and disappeared round the west limb on February 17. "The total spotted area measured on the photographs taken at Greenwich on February 13, when the group reached its maximum, was no less than 1/350 of the sun's visible hemisphere. At Greenwich the area of spots is measured in millionths of the sun's visible hemisphere, and this extensive group had an area of 2850 millionths, corresponding to 3360 millionths of square miles. The centre of the group was then at 26° long., and in lat.  $-23^\circ$ . The group was a broad band extending over 22° of longitude in length and 10° of latitude in width, corresponding roughly to a greatest length of 150,000 miles and a width of 75,000 miles. The large central spot of the group was 15" in length in longitude and 8" in width in latitude. The spot-group is the largest ever photographed at Greenwich, and is the largest which has appeared on the sun since 1873."

A NEW COMET.—Prof. Lewis Swift, of the Warner Observatory, discovered a comet on March 6 in R.A. 18<sup>h</sup>. 59<sup>m</sup>, and N.P.D. 121° 20'. Unfortunately the comet is at present too far south to be seen in these latitudes.

PROF. KRUEGER (*Astronomische Nachrichten*, No. 3077) contributes an important paper on the determination of the perturbations set up in the motions of periodic comets as they approach the sun, owing to their proximity to the planets.

#### PHOSPHOROUS OXIDE.

IN addition to the well-known pentoxide formed when phosphorus is burnt in air or oxygen, a second oxide of phosphorus has long been surmised to exist. Very little, however, has hitherto been known concerning this second oxide. It is usually described in current chemical literature as a white amorphous powder of the composition  $P_2O_5$ , very voluminous, somewhat more volatile and more readily fusible than the pentoxide  $P_2O_5$ , and instantly dissolved with great rise of temperature by water, with formation of phosphorous acid. During the last three years an investigation has been carried out in the laboratory of the Royal College of Science by Prof. Thorpe and the writer, which has resulted in showing that phosphorous oxide is a substance possessing properties entirely different from these. Full details of this work have recently been laid before the Chemical Society, but a short account of the manner in which the pure oxide has been isolated in quantity, of its somewhat remarkable properties, and of a few of its more important reactions, may, perhaps, not be uninteresting to readers of NATURE.

#### Properties of Phosphorous Oxide.

Before describing the mode of preparing the oxide, it will be advisable to briefly indicate the external appearance and essential properties of the substance. Phosphorous oxide is not an amorphous powder, but, at temperatures not exceeding 22° C., a pure white crystalline solid, compact and heavy, soft and wax-like in character. Its most striking property is the ease with which it melts, the warmth of the hand which holds the vessel containing it being more than sufficient to convert it to the liquid state. Its melting point is 22° 5 C., hence upon a warm summer's day or when placed in a warm room it takes the form of a clear, colourless liquid, very mobile, but somewhat heavy. It is best preserved in sealed glass tubes, the air of which has been replaced before the introduction of the oxide by carbon dioxide or nitrogen in order to avoid the action of the oxygen contained in air, which rapidly converts phosphorous oxide to phosphoric oxide. When such a tube containing the liquid oxide is cooled by immersing it in cold water or allowing it to stand in a room of ordinary temperature (17°-



20° C.) the oxide rapidly resolidifies in a most beautiful manner, large crystals shooting out in all directions until the whole is one compact mass of interlacing crystals. When the liquid is heated in a distillation flask previously filled with one of the indifferent gases carbon dioxide or nitrogen, it soon commences to boil, and the vapour condenses in the condensing tube and the unchanged oxide runs down into the receiver placed to intercept it in the form of liquid, which eventually condenses to the solid again. Its boiling point is 173°-1 C.

The vapour of phosphorous oxide possesses a very characteristic odour, which appears to be the same as that so noticeable about a lucifer-match manufactory. Owing to its great volatility, both the solid and the liquid are constantly vapourizing, even at the ordinary temperature, and hence the odour is always strongly marked in their neighbourhood.

Phosphorous oxide may also be obtained by spontaneous evaporation *in vacuo* in beautiful large isolated crystals, probably belonging to the monoclinic system, which are quite colourless and transparent, and very highly refractive; crystals have frequently been obtained in this manner an inch in length and broad and thick in proportion, showing numerous prism and pyramid faces. Similar crystals are obtained when solutions of the oxide in carbon bisulphide, chloroform, ether or benzene, in which the substance readily dissolves, are evaporated out of contact with the air.

Instead of reacting with violence with water, as appears to have been generally supposed, phosphorous oxide is com-

these volatile crystals in larger quantity, and of separating them entirely from the pentoxide, a method has at length been found by which as much as twenty-eight grams of the pure oxide have been obtained in an experiment of five hours' duration.

Two sticks of phosphorus are cut into pieces about an inch and a half long, and placed in a glass tube bent into the shape shown at *a* in the figure, so as to retain the phosphorus when in the melted condition. The tube should be of 1½-inch bore, and should be made from *new* soft glass tubing, which is quite hard enough to stand the heat of burning phosphorus. The tube is drawn out somewhat, but quite open, at the end where the air is to be admitted, and at the other is narrowed slightly, so as to fit into the condenser *b*, a tight joint being obtained by means of a caoutchouc ring or a little bicycle cement. This condenser, *b*, is intended to retain the phosphorus pentoxide and any free phosphorus produced during the combustion, and is maintained at such a temperature that the phosphorous oxide passes uncondensed through it. It is therefore constructed of brass instead of glass, and is made double, that is, with an outer jacket also of brass, so that the space between the two brass tubes may be filled with water of the required temperature. This water may be run in by means of a funnel through a small vertical tube, *d*, a second such tube, *e*, serving for the introduction of a thermometer. The size of condenser found most convenient is 2 feet in length, and the inner brass tube has a bore of 25 millimetres. At the end of the condenser furthest from the phosphorus, a plug of glass wool about half an inch long is inserted, the

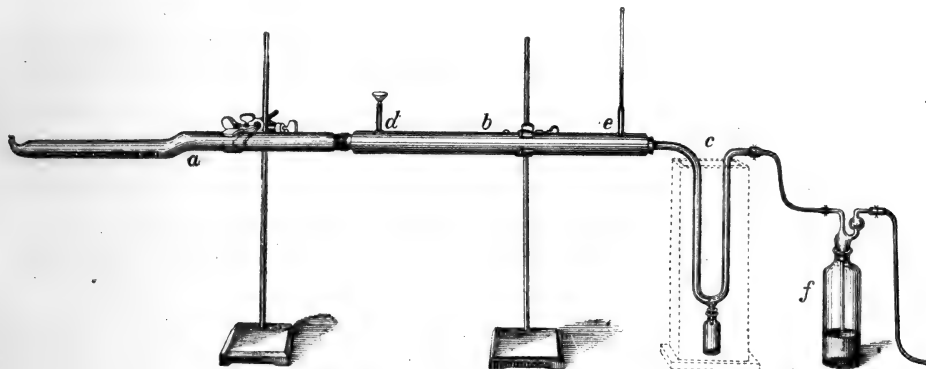

Apparatus employed for the preparation of phosphorous oxide.

paratively indifferent to that liquid, only dissolving with great slowness. If a few drops of the liquefied oxide are dropped into water of about the same temperature they at once fall to the bottom of the tube, and the two liquids do not mix. If the water is at the ordinary temperature the oxide solidifies as it falls to the bottom. A few grams of the oxide, either liquid or solid, require several hours for complete solution. The solution contains phosphorous acid. When phosphorous oxide is warmed with water to a temperature just below 100°, a violent reaction of an entirely different nature occurs; spontaneously inflammable phosphoretted hydrogen is evolved with a loud explosion, and red phosphorus and phosphoric acid are largely formed.

#### Preparation of Phosphorous Oxide.

It is quite a mistake to suppose that when phosphorus is burnt in a combustion-tube in a slow current of air the lower oxide, and not phosphorus pentoxide, is produced. Scarcely a trace of phosphorous oxide is obtained under these circumstances, the white amorphous powder deposited being pentoxide. It is only when the current is at all rapid that phosphorous oxide commences to be formed. Its advent is at once apparent, as it crystallizes all along the upper portion of the horizontal combustion-tube in beautiful feathery crystals, which at once melt if the finger is laid upon the exterior of the tube, while the pentoxide settles out along the bottom of the tube. After several less successful attempts to devise a method of producing

fibres being arranged transversely as much as possible; such a plug forms an excellent means of filtering off any pentoxide which would otherwise escape into the phosphorous oxide condenser, especially after the first few minutes of the combustion, when its meshes become loosely filled with porous pentoxide. Directly into the end of the brass condenser fits tightly, by means of a cork annulus, the large glass U-tube condenser, *c*, in which the phosphorous oxide is condensed. The yield of oxide appears to depend somewhat upon the shape and dimensions of this condenser, that found most advantageous having the shape shown in the diagram, a height of 35 centimetres from the bottom of the bend, and an internal bore of 14 millimetres. A short vertical tube is fused on at the bend, and passes down into a bottle, into which the oxide may be melted at the end of each combustion. The whole condenser is surrounded by a tall wooden box, indicated by dotted lines in the figure, containing pounded ice. To the end of the condenser is attached a wash-bottle, *f*, containing sulphuric acid, which serves to prevent access of moisture to the oxide condensed in the U-tube, and also to measure the rate of the current of air drawn through the apparatus by the water pump.

In making a preparation, as soon as the phosphorus, dried by blotting-paper, has been introduced and the tube containing it attached to the brass condenser, which at first is quite cold, the phosphorus is warmed to the igniting point and the pump set working by turning on the water-tap to which it is firmly

attached. After about ten or fifteen minutes, crystals begin to make their appearance in the U-tube; the oxide then rapidly collects in the form of a waxy mass. The best refrigerator for the U-tube is pounded ice; if salt is mixed with it, the oxide condenses so rapidly in the first cooled portion of the condenser as to form a bridge and stop the operation until it is melted down. When nearly half of the phosphorus is burnt, the brass condenser is warmed by pouring in water heated to about 70°–80° C., and the condenser is maintained at this temperature until about three-quarters of the phosphorus has been burnt, when the operation is stopped by slowly turning off the water working the pump.

When phosphorus is burnt under these conditions, three oxides are produced; more or less of the red suboxide  $P_2O$  is always deposited in the immediate neighbourhood of the burning phosphorus, a certain amount of pentoxide is formed and retained in the glass tube beyond the seat of combustion and in the brass condenser, and phosphorous oxide is produced in large quantity, and, being considerably more volatile, is carried forward to the cooled condenser, any which may be deposited in the brass condenser during the earlier stages of the combustion being carried along into the U-tube in the current of escaping nitrogen when the warm water is introduced into the brass condenser. Scarcely a trace of pentoxide escapes through the glass wool filtering plug, the product in the U-tube being almost pure phosphorous oxide. In the course of five hours three such charges of phosphorus may be burnt out and the total phosphorous oxide produced, which should amount to at least twenty grams, can be condensed in the same U tube, the product from each charge being melted down into the bottle so as to prevent choking of the tube. In order to free the product from any traces of impurity, it should be distilled in a slow current of carbon dioxide, when it condenses in the receiving tube as an absolutely clear liquid which soon solidifies to a snow-white mass of crystals. The tube should be at once sealed and, for a reason which will be found under the *Action of Light*, kept in the dark.

#### *Molecular Composition of Phosphorous Oxide.*

Quantitative analysis of the substance whose properties and mode of preparation have just been described of course yields numbers which agree with the empirical formula  $P_2O_3$ . But as the oxide is volatile it was of the first importance to determine its vapour density, with the view of obtaining information regarding its molecular weight. This determination was the more interesting from the fact that Prof. Victor Meyer had previously found that the analogous oxides of arsenic and antimony gave vapour densities corresponding to the double molecular formulæ  $As_2O_6$  and  $Sb_2O_6$ , and also from the fact that the molecule of phosphorus itself is found to contain four atoms. The vapour density was determined by Hoffmann's well-known method in the Torricellian vacuum at the temperatures of boiling amyl alcohol (132°), oil of turpentine (159°) and aniline (184°). The numbers obtained from several such determinations are in perfect accordance with the molecular weight corresponding to the double formula  $P_4O_6$ . This result has been fully confirmed by a determination of the molecular weight by the totally different method of Raoult, which depends upon the degree of lowering of the freezing point of a solvent, in this case benzene, by the introduction of a small quantity of the substance undergoing investigation.

Hence phosphorous oxide must be symbolized by the formula  $P_2O_3$  and not  $P_2O_5$ , phosphorus thus resembling its family relatives arsenic and antimony in the nature of its lower combination with oxygen.

#### *Physical Properties of Phosphorous Oxide.*

The specific gravity of the solid oxide at 21° C., compared with water at 4° is 2.135, and that of the liquid oxide at 24° 8' is 1.9358. Hence there is about nine per cent. of contraction upon the passage of the liquid into the solid state.

A somewhat interesting result has been obtained from the determination of the specific volume, that is, the number obtained by dividing the molecular weight by the density at the boiling point. The actual density, of course, cannot be experimentally determined at the temperature of ebullition, but by making a careful determination of the rate of expansion and knowing the density very precisely at some lower temperature the density at the boiling point can be calculated. The value thus found for the specific volume was 130.2. Now, phosphorus is known to possess two specific volumes; one in the state of

combination (as determined from its halogen derivatives) and which is somewhere about 25.3, and another when in the free state, which is approximately 20.9. Oxygen, too, is usually supposed to have two values, one of 7.8 when it is linked to two different atoms, single linkage as it is termed, and another of 12.2 when doubly linked to one and the same atom of another element. If we subtract six times 7.8, that is deduct the specific volume due to six atoms of oxygen, from the specific volume 130.2 of phosphorous oxide, we arrive at the number 83.4 for four atoms of phosphorus, or 20.9 for that of one atom. If any of the oxygen atoms were doubly linked the number would be considerably less than 20.9, hence this number represents the greatest possible value of the phosphorus in phosphorous oxide.

It would appear, therefore, that the phosphorus in phosphorous oxide possesses the same specific volume as free phosphorus itself, a result of interest in view of the fact revealed by the determinations of molecular weight that there are four atoms of phosphorus in the molecule of the oxide just as there are in the molecule of free phosphorus itself.

The liquid oxide, considering that it contains such a highly refractive substance as phosphorus, possesses a remarkably low power of refracting light. Its refractive index at 27° 4 C. is only 1.5349 for the red line of lithium, and 1.5614 for the blue hydrogen line G. Not only is the refractive index of phosphorus (2.0677 for the red hydrogen line C) enormously reduced by its combination with oxygen, but the length of the spectrum is reduced to about one-fifth.

#### *Action of Light.*

Phosphorous oxide, in the white wax-like solid form in which it usually condenses after distillation, is remarkably sensitive to light. Ten minutes exposure to bright sunshine suffice to turn it red, and after half an hour it is rendered quite dark red. The red substance which is formed is the red modification of phosphorus, but even after several months' exposure the amount produced has never been found to exceed 1 per cent. of the weight of the oxide. The beautiful isolated crystals obtained by sublimation *in vacuo* appear to be unaffected by light, but it is a curious fact that if one of them is melted by the warmth of the hand, and the liquid globule afterwards suddenly cooled to the wax-like form, the latter becomes red on exposure to daylight. Whether the reddening is due to the conversion of small quantities of admixed yellow phosphorus into red phosphorus, or to the decomposition of the waxy form of the oxide by light, there is not yet sufficient data to determine.

#### *Action of Heat.*

It has been seen that the oxide boils without decomposition at 173° 1. It may be heated in a closed tube to considerably over 200° without change. It commences to decompose, however, between 210° and 250°, becoming turbid from the separation of solid decomposition products, one of which is free phosphorus, which becomes more and more deeply coloured until at 300° it is quite red. At about 400° the oxide is totally decomposed into solid products, consisting of both yellow and red phosphorus and phosphorus pentoxide. Occasionally, when only the lower half of the tube has been immersed in the heating bath, the formation of crystals has been observed in the cooler portion of the tube, which appear to be identical with some described in a previous communication to the Chemical Society which gave numbers on analysis agreeing with the formula  $P_2O_4$ , and which yielded a solution with water capable of reducing mercuric chloride to calomel. Hence the final decomposition by heat may be expressed by the equation



but under suitable circumstances the intermediate formation of the tetroxide may occur according to the equation

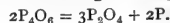

#### *Action of Oxygen.*

Phosphorous oxide takes up oxygen spontaneously at the ordinary temperature. It is probable, however, that the oxygen only reacts in the cold with the vapour. For if a small quantity of the oxide is placed at the bottom of a glass tube closed at one end and previously filled with oxygen, and the tube is sealed and left in the dark in an upright position, the oxide is gradually converted to a voluminous mass of pentoxide,

which is deposited in a most beautiful manner in regular annuli all up the tube to the very top. When the oxide is placed in contact with oxygen in an apparatus in which the pressure can be rapidly diminished, the oxidation is seen to be accompanied by a phosphorescent glow, flickering up and down throughout the whole inclosed space, similar to that which occurs under the same circumstances with phosphorus itself. Moreover, this phenomenon is observed with the purest specimens distilled *in vacuo*. If the temperature is increased, the phosphorescence is brought about at pressures near the atmospheric, and if it is raised to 70° C., phosphorescence gives place to actual combustion, which, however, may be at once reduced to mere phosphorescence by diminishing the pressure. If the oxide is thrown into oxygen warmed to about 50°, it immediately burns to the pentoxide with a most brilliant flash of flame.

#### Action of Halogens.

When phosphorous oxide is thrown into a vessel containing chlorine gas, it instantly takes fire and burns with a pale green flame. If chlorine is led over the oxide at the ordinary temperature, violent combustion also occurs; but if the vessel containing the oxide is cooled by ice, the reaction occurs in a more moderate manner. The product is a clear liquid which is found to be a mixture of phosphorus oxychloride,  $\text{POCl}_3$ , which may be distilled off, and metaphosphoryl chloride,  $\text{PO}_2\text{Cl}$ , which remains as a viscous residue after the distillation of the phosphorus oxychloride. The reaction occurs in complete accordance with the equation

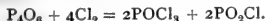

Bromine also acts with considerable violence upon the oxide, generally with incandescence. Analogous products are eventually obtained as in the case of chlorine; but if the experiment is so arranged that the vapours of the two substances only are allowed to react at the ordinary temperature, an intermediate reaction occurs with deposition of annuli of large and very perfect crystals of phosphorus pentabromide,  $\text{PBr}_5$ , phosphorus pentoxide being also formed at the surface of the phosphorous oxide.

Iodine only slowly reacts with the oxide, and best when the two substances are dissolved in carbon bisulphide and the solution heated in a sealed tube. On cooling, orange-red crystals of  $\text{P}_2\text{I}_4$  separate out.

#### Action of Sulphur—Formation of a Sulphoxide of Phosphorus.

Sulphur reacts with the oxide in a most interesting manner, producing a beautifully crystalline addition compound of the empirical formula  $\text{P}_2\text{O}_3\text{S}_2$ . The reaction is best carried out in a sealed tube, about five grams of the oxide and the corresponding quantity of sulphur being placed together in the tube, which has previously been filled with carbon dioxide or nitrogen. The tube is fixed upright, and its lower portion, containing the mixture, is heated in a glycerine bath. No reaction occurs, the two liquids remaining in separate layers, until a temperature in the neighbourhood of 160° is attained, when sudden and very violent combination takes place, the tube being usually shattered into fragments if more than 5 grams of the oxide are employed. The sulphoxide produced is a pale yellow solid substance which melts at about 102°, and boils without decomposition at 295°. When heated *in vacuo* it sublimes largely in the form of tetragonal prisms of considerable size, quite colourless and transparent; a certain amount frequently condenses in a vitreous form, which eventually devitrifies into feathery aggregates of the tetragonal prisms. Occasionally long needles, elongated tetragonal prisms, are formed. A very slight residue usually remains of sulphur, to which the yellowish colour of the crude product is probably due. The sulphoxide is soluble in carbon bisulphide, and the solution deposits it again in tetragonal prisms on evaporation.

As phosphorus sulphoxide is undecomposed even at 400° C., it has been found possible to determine its vapour density by Victor Meyer's method in an atmosphere of nitrogen. The numbers obtained agree with the double formula  $\text{P}_2\text{O}_3\text{S}_2$ . Hence phosphorus sulphoxide is a direct sulphur addition product of phosphorous oxide.

It is deliquescent, and is decomposed by water with liberation of sulphuretted hydrogen and formation of phosphoric acid.

#### Other Reactions of Phosphorous Oxide.

Ammonia gas, when led over melted phosphorous oxide, causes immediate ignition of the mass. When the oxide is

dissolved in ether, however, the action is more manageable, and a new white solid compound is formed. This compound is

the diamide of phosphorous acid,  $\text{P} \begin{matrix} \text{NH}_2 \\ \diagup \\ \text{NH}_2 \\ \diagdown \\ \text{OH} \end{matrix}$ . It is an amorphous

powder which dissolves instantly in water with production of flame. Dilute hydrochloric acid liberates pure non-spontaneously inflammable phosphoretted hydrogen from it, owing to the decomposition, at the high temperature brought about by the reaction, of the phosphorous acid first produced.

Hydrochloric Acid gas converts the oxide into phosphorus trichloride and phosphorous acid, the former being readily decanted from the latter at the close of the experiment.

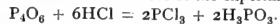

Concentrated sulphuric acid deflagrates violently with phosphorous oxide with production of flame, formation of phosphoric acid, and liberation of sulphur dioxide.

Caustic alkalis, when tolerably concentrated, at once decompose the oxide with production of a flame of burning phosphoretted hydrogen, red phosphorus being deposited, and a phosphate formed.

Sulphur chloride and phosphorus pentachloride respectively react with great energy with the oxide, the resulting liquid products being immediately raised to the boiling-point. When the reactions are performed in vessels cooled by ice, the products may be collected and examined. Sulphur chloride yields a mixture of oxychloride and sulphochloride of phosphorus,

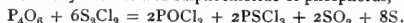

Phosphorus pentachloride produces a mixture of oxychloride and trichloride of phosphorus,

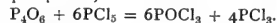

Ethyl alcohol instantly sets fire to phosphorous oxide. The reaction may readily be moderated, however, by cooling the vessel by ice, and under these circumstances a new liquid, diethyl

phosphorous acid  $\text{P} \begin{matrix} \text{OC}_2\text{H}_5 \\ \diagup \\ \text{OC}_2\text{H}_5 \\ \diagdown \\ \text{OH} \end{matrix}$ , is produced. This liquid possesses

a strong garlic-like odour, boils at 184°–185°, and has a specific gravity of 1.0749 at 15° 5'.

An account of the properties of phosphorous oxide would not be complete without a reference to its physiological action. Most people are aware that persons engaged in lucifer-match making occasionally suffer terribly from disease of the lower jaw, and it is found that this is due to the direct action of the fumes upon the bone. It would appear that this deplorable action is directly traceable to the vapour of the volatile phosphorous oxide now described, for this oxide is found to be largely formed when phosphorus oxidizes without igniting; and if any benefit in the way of increased precautions against such action should follow from the further knowledge now gained concerning this substance, none will rejoice more heartily than those who have attempted to place its chemical history upon a surer foundation.

A. E. TUTTON.

#### UNIVERSITY AND EDUCATIONAL INTELLIGENCE.

OXFORD.—Mr. George B. Grundy, B.A., Brasenose College, has been elected to a Geographical Studentship (see November 19, 1891, p. 70). This student, after preliminary study at Oxford, or at some other place appointed by the electors, will be expected to reside at least three months in the region he is investigating, and to forward the results of his work to the Royal Geographical Society.

A meeting of the Ashmolean Society was held in the Museum on Monday, March 7, Mr. E. B. Poulton, F.R.S., in the chair. The Rev. F. J. Smith, Trinity College, Mellard Lecturer, was prevented by illness from giving his paper on some of the uses of photography in scientific research. Mr. Veley, University College, read a paper on some chemical transformations of nitric and nitrous acids.

MR. F. E. WEISS, Assistant Professor of Botany at University College, London, has been appointed Professor of Botany at Owens College, Manchester.

Mr. Wyndham R. Dunstan, the Director of the Research Laboratory connected with the Pharmaceutical Society, has been elected Lecturer on Chemistry at St. Thomas's Hospital Medical School, in succession to the late Dr. Bernays.

## SCIENTIFIC SERIALS.

*American Journal of Science*, February.—On the use of a free pendulum as a time standard, by T. C. Mendenhall. The accuracy with which we measure hours, minutes, and seconds is dependent upon our ability to subdivide the sidereal day by mechanical arrangements, e.g. chronometers and clocks. The author believes that a free pendulum, vibrating under constant conditions, furnishes a much more trustworthy standard for short intervals of time than any clock or chronometer. To determine the period of such a pendulum, a small mirror is placed in a vertical plane on the pendulum head, and another is placed parallel to it, but rigidly attached to the support upon which the pendulum swings. At a distance of about a metre, an apparatus is arranged which illuminates a slit at intervals of a second. Each of the two mirrors reflects images of the illuminated slit to an observing telescope, and the arrangement is such that when the pendulum is at rest, or at its lowest point, the two images just overlap. Suppose this overlapping to be observed at any instant, then, if the chronometer which makes the current for the illumination of the slit, and the pendulum, have the same period, or if they differ by half a period, the same appearance would be observed continually. But if the two differ by an extremely small amount, the image from one of the mirrors will be a little above or below the image of the other when the slit is illuminated, and the distance separating them will go on increasing until the pendulum has gained or lost one oscillation. Such a pendulum and accessories can be used to compare one chronometer with another or with a clock. And the great advantage it possesses is that in an hour or less a daily rate can be determined, correct to about three-hundredths of a second.—On the Bear River formation, a series of strata hitherto known as the Bear River Laramie, by Dr. Charles H. White.—The stratigraphic position of the Bear River formation, by T. W. Stanton. The object of these two articles is to show that the strata which have hitherto been known as Bear River Laramie are not only not referable to the Laramie formation, but that they occupy a lower position, being overlain by marine Cretaceous strata the equivalents of which are known to underlie the true Laramie.—The iron ores of the Marquette district of Michigan, by C. R. Van Hise.—An illustration of the flexibility of limestone, by Arthur Winslow.—The separation of iron, manganese, and calcium, by the acetate and bromine methods, by R. B. Riggs.—The Central Massachusetts moraine, by Ralph S. Tarr.—Proofs that the Holyoke and Deerfield Trap sheets are contemporaneous flows, and not later intrusions, by Ben. K. Emerson.

THE *Quarterly Journal of Microscopical Science*, vol. xxxiii., Part I (December 1891), contains:—Dr. Marcus M. Hartog, Some problems of reproduction: a comparative study of gametogeny and protoplasmic senescence and rejuvenescence (pp. 1-80). This important paper cannot be summarized within the space at our disposal; the table of contents runs to two pages, and the theses which state concisely the results of the inquiry are twenty in number, extending over three pages.—Herbert E. Durham, On wandering cells in Echinoderms, &c., more especially with regard to excretory functions (plate i.). Following up his researches on the emigration of amoeboid corpuscles in starfish, the author of this paper inquires as to the subsequent fate of the pigment-containing corpuscles in other animals, selecting *Dytiscus marginalis* for this purpose. In the irregular Echinids the process of removal of products from the body by means of amoeboid cells was seen to be more definitely associated with pigment; these wandered out at any point of the free surface of the body, in the neighbourhood of the circumoral rosette feet, and in the feet themselves, or into the tubes of the madreporite. In the consideration of this subject the great importance of these two processes—the reaction to minute foreign bodies, and the use of the wandering cells in getting rid of effete material from the system—are insisted upon, and numerous weighty and important facts are detailed. In notes on Echinoderm histology the dorsal organ is minutely described, and its functions are detailed.—Sidney F. Harmer, On the nature of the excretory processes in marine Polyzoa (plates ii. and iii.). A series of interesting investigations, made at the Zoological Station at Naples, go to confirm the view that the marine Ectoprocta are not provided with definite nephridia; and appear to show that the excretory processes are carried on principally by the "brown bodies," the funicular (connective) tissue, and the free mesoderm cells contained in the meshes of the latter.—J. T. Cunningham, Spermatogenesis in *Myxine glutinosa* (plate

iv.). These investigations as to the development of the spermatozoa in this hermaphrodite fish were carried on at Alverstrømmen, some twenty miles to the north of Bergin. The author confirms in great measure his previous work, but he failed to find fertilized ova.—Dr. W. Blaxland Benham, Notes on some aquatic Oligochaeta (plates v. to vii.). We have notes on the anatomy and histology of *Heterochaeta costata*, Claperède; a note on *Spirosperma ferox*, Eisen; on a species of Psammoryctes; note on the chaetae of *Tubifex rivulorum*; on *Stylodrilus vejdoskyi*, n. sp., found just below Goring-on-Thames; note on *Nais elinguis*; on the supposed constancy of *n* in a given species of Naid, *n* being the position of the zone of budding, the numbers following signifying the number of segments in front of the zone.—Charles Slater, on the differentiation of leprosy and tubercle bacilli. As any staining agent which will colour the leprosy bacillus will also stain the tubercle bacillus, the methods proposed to stain the one leaving the other unstained are untrustworthy, and the apparent differences in respect to rapidity of staining and resistance to decolorization are due to difference in numbers of bacilli present.—Charles Stewart, On a specimen of the true teeth of *Ornithorhynchus* (plate viii.).

Part 2, January 1892, contains:—Arthur E. Shipley, On *Onchocoma stenstrupii* (plate ix.), describes the minute anatomy of this the smallest Spiculid known, one of three species, all of which have been described from the north-west coast of Norway. The head is much simplified; the lip surrounding the mouth bears no tentacles, but is produced dorsally into a blunt ciliated process; there are neither tentacles, hooks, collar, pigmented skin, or eyes; there is no vascular system, no spindle muscle, and no giant cells are found in the brain, which latter is not bilobed. The retractor muscle is single, arising from the posterior end of the body; the nephridium is also single. Nothing is known as to its development.—Edward A. Minchin, Note on a sieve-like membrane across the oscula of a species of *Leucosolenia*, with some observations on the histology of the Sponge (plates x. and xi.). In a species of *Leucosolenia*, probably *L. coriacea*, found at Plymouth, a thin perforated membrane was found stretching across the oscular openings. This membrane occurs a little below the actual margin of the opening, varies in size with the oscula, but is imperforate in the very smallest openings; it is composed of two layers of cells in apposition; these are separated by a thin layer of jelly. The author suggests an analogy between this membrane and the well-known sieves in some of the Hexactinellid Sponges, and severely criticizes Von Lendenfeld's homologies concerning oscular sieve plates. Some new points about the ectoderm and endoderm are alluded to.—Ernest W. MacBride, The development of the oviduct in the frog (plates xii. and xiii.). The author states the principal new points as follows: (1) the oviduct arises opposite the first and not the third nephrostome of the pronephros; (2) the whole of the duct and not merely its posterior half, as Hoffman supposed, arises apparently by proliferation from a strip of modified peritoneum, entirely independent of the Wolffian duct; (3) the lumen appears quite close to the peritoneum and in patches.—Margaret Robinson, On the nauplius eye persisting in some Decapods (plate xiv.). The nauplius eye has been described as persisting in Schizopods, and has been referred to by Dr. Paul Mayer as occurring in Palæmonetes, but the author describes and figures it as found by her in several species of Decapoda, *Pandalus annulicornis*, *Vibrius varians*. As regards the shape of the pigment cells, the position of their nuclei, and the arrangement of the nerve end cells in three groups, these eyes exactly resemble the median eye of Branchipus as described by Claus.—Dr. W. Blaxland Benham, Notes on two Acanthodriloid Earthworms from New Zealand (plates xv. and xvi.), describes *Plagiochaeta punctata*, n. gen. et sp.; this new genus has apparently affinities with *Pericheta* and with *Acanthodrilus*. Also describes *Neodrilus monocystis*, Beddard.—Asajiro Oka and Arthur Willey, On a new genus of Synascidians from Japan (plates xvii. and xviii.). This remarkable Compound Ascidian was found in some quantities at Morioiso, a place on a small bay to the north of Misaki, some fifty miles south of Tokio. It belongs to the Didemniidae, and has been called *Sarcodidemnioides misakiensis*. The colour is a brilliant red, and the surface of the colony is smooth and glistening; at the tips of the round knob-like lobes, which are a very characteristic feature of the genus, are seen the small but extinct excurrent orifices, the lips of the pores being slightly raised above the level of the surrounding surface.

## SOCIETIES AND ACADEMIES.

LONDON.

**Royal Society, February 11.**—"Contributions to the Physiology and Pathology of the Mammalian Heart." By Prof. Roy, M.D., F.R.S., and J. G. Adami, M.A., M.B.

The authors have spent several years in attempting to give to the study of the intact mammalian heart the accuracy which has been attained in the study of the heart of cold-blooded animals. They described two instruments which had been found by them to be of especial value: one which they term the *cardiometer* (a form of cardiac plethysmograph or oncograph); the other, the *myocardiograph*, by means of which records were obtained of the contraction and expansion of the muscle between two points upon the surface of either ventricle, or of ventricle and auricle simultaneously. They pointed out the ease wherewith cardiac tracings may be misinterpreted if certain elements of the mechanics of the heart be not constantly kept in mind. Thus, if, when the chambers of the heart become expanded, there is a lessening of the extent to which at each systole the muscle fibres contract, this does not mean that the contractile force is weakened; for with increase in the contents of the cavities of the heart there is increased strain (or weight) thrown upon the walls, and a comparatively slight diminution in the circumference of the expanded ventricle suffices to expel the same amount of blood, whose expulsion, when the ventricle is but little expanded, is accompanied by great diminution in circumference. Thus, in considering the action of the vagus upon the heart, it was shown that stimulation of this nerve does *not* cause loss of ventricular force of contraction. Moderate stimulation induces weakening or paralysis of the auricles, accompanied by ventricular dilatation. This dilatation is due to the increased venous and intraventricular pressure accompanying the slowed rate of beat. And though, as shown by the myocardiograph, there is now lessened systolic contraction of the ventricular wall, and also lessened output in a given time, each individual contraction leads to the expulsion of an increased quantity of blood. The only direct action of the vagus upon the ventricles, according to the authors, is a diminution of the excitability of the ventricular muscle. Upon continued fairly strong vagus excitation the auricular rhythm is weakened or inhibited, and does not suffice to set up the normal "sinus," or post-auricular rhythm of the ventricles; so for a time the ventricles usually cease to beat; but soon the independent idio-ventricular rhythm manifests itself, the same that is to be seen when, after the methods of Wooldridge or Tigerstedt, the mammalian auricles and ventricles are cut off from one another; or, again, shows itself after muscarin poisoning. Experiments of the authors and early observations of Einbrodt were mentioned proving this contention. With a certain degree of vagus excitation, irregularity of the ventricles results in consequence of the sinus and idio-ventricular rhythms interfering with one another. In the dog this is the common form of irregularity; probably this is also true for man.

The authors conclude that the term *nervi augmentores* is better and more comprehensive than that of *nervi accelerantes cordis*. Excitation of these nerves in the dog leads more often to augmentation in the force than in the frequency of contraction: the two effects do not by any means go hand-in-hand.

Vagus excitation relieves the heart of work, and therefore of waste, to as great an extent as is compatible with a continuance of the circulation; the vagus may therefore be looked upon as primarily the protective nerve of the heart, and secondarily it was shown to act in the interests of the central nervous system; while the presence in the sciatic and other mixed nerves of fibres which cause reflex vagus excitation would seem to indicate that the nerve may be used by other parts of the body to diminish the output of the heart, and so to reduce the activity of the circulation as a whole. The idio-ventricular mechanism must be looked upon as a means whereby arrest of the circulation—and death—is prevented when the vagus action exceeds a certain limit.

The augmentor nerves, on the other hand, increase the work and tissue waste of the heart, this organ being sacrificed for the needs of the economy until the vagus is called into play by cardiac reflex. The output is increased, and the ventricles are enabled to pump out their contents against heightened arterial blood pressure.

Other considerations dealt with by the authors were: the mode of interaction of the vagi and augmentores, and factors

other than nervous—affecting the force of the heart's contractions; for example, the blood pressure in the coronary arteries; changes in the volume and in the constitution of the blood, asphyxia, fatigue, and organic disease; the part played by the nerves in all these cases being especially taken into consideration.

**February 25.**—"The Electric Organ of the Skate: Observations on the Structure, Relations, Progressive Development, and Growth of the Electric Organ of the Skate." By J. C. Ewart, M.D., Regius Professor of Natural History, University of Edinburgh. Communicated by Prof. J. Burdon Sanderson, F.R.S.

After referring to the observations of Stark, the discoverer of the skate's electric organ, and to the work of Robin, Leydig, Babuchin, and others, the author describes the arrangement of the muscles in the tail of Selachians with a view to determining which muscles in the skate are transformed into the electric organs.

By comparing the caudal muscles of *Scyllium*, *Lamna*, *Myliobatis*, and *Raia*, it is made out that, while the middle row of muscular cones remains unaltered in the sharks and rays, it is transformed into a more or less perfect electric organ in the skates the various members of the genus *Raia*. It is pointed out that, while the middle row of muscular cones is transformed in *Raia* into electric cones, the two adjacent rows of cones, as in the rays and certain sharks, diminish in size, and in some cases disappear about the middle of the tail.

In considering the structure of the organ, it is stated that, when the various modifications are taken into consideration, it may be described as consisting of a series of electric cones made up of more or less completely metamorphosed muscular fibres. Twenty-eight distinct cones were counted in the organ of *R. batis*. The first, which in a half-grown fish measured 5 cm. in length, was all but completely invested by the last unaltered muscular cone. From the first to the tenth the cones slightly increased in length; but from the eleventh they diminished in length, the twenty-sixth measuring only 0.75 cm. Beyond the twenty-eighth there were from six to eight incomplete cones.

In transverse sections the anterior third of the organ was seen to present an oval or rounded form, while the middle and posterior thirds were less regular, owing to the organ coming into contact with the vertebral column, and being grooved by the dorsal and ventral muscles.

The cones are described as consisting of numerous loculi or chambers, each having an electric disk suspended by nerve fibres from its anterior wall, and occupied in front and behind the disk with gelatinous tissue.

It is estimated that each organ in *R. batis* is made up of about 10,000 electric elements, i.e. about 20,000 in the two organs. *Torpedo marmorata* has about 500,000, and *T. gigantea* about 1,000,000, elements in the two batteries, all considerably larger than those of the skate.

The layers of the electric disks, the electric, striated, and alveolar, are described in detail; and the vari-ous views as to the termination of the nerve fibrils in the disk are referred to.

In the chapter on the progressive growth of the organ a table is given to show that in *R. batis* the organ, after a time, grows at a greater rate than the tail in which it is lodged: e.g. in fish 60 cm. in length the tail measures about 28 cm., and the electric organ 22.5 cm.; well-formed disks having an area of 0.8 to 1 sq. mm. In fish 225 cm. in length the tail measures 85 cm., the organ 70 cm., and the disks have an area of about 2.08 sq. mm. In fish from 25.5 to 30.5 cm. in length the organ is from 12.78 to 14.0 cm., and weighs 0.5 to 0.6 gram; in fish from 83.5 to 91.25 cm. the organ is from 30.50 to 34.25 cm., and weighs from 6.0 to 8.0 grams; in fish 157 cm., the organ measures 48.25 cm., and weighs 25.00 grams; while in 225 cm. fish the organ, which measured 70.00 cm., weighed 156.00 grams. These facts, especially the great size and weight of the organ in large skate (about 7 feet in length), do not seem to point to the skate's organ being in process of degeneration; more especially as the increase in size is not accompanied by any histological changes of a retrogressive nature, the largest organ examined being apparently as perfect as that of *Torpedo* and *Gymnotus*.

In discussing the organ from a physiological point of view, reference is made to the investigations of Sanderson and Gotch, and it is pointed out that, when the electric plate is taken as the unit, the value per square millimetre of the single plate of the skate is in all probability equal to, if not greater than, that of the torpedo.

The structure of organs of the skate and torpedo are compared at length, and it is shown that in the case of the torpedo all the non-essential structures are absent; while the all-essential part, the electric layer or plate, closely resembles the corresponding layer or plate in the skate; the electric layer of *R. circularis* being especially like that of the torpedo.

In considering the modifications of the electric organ in the skate genus, it is shown that in all the British species, with the exception of *R. radiata*, *R. circularis*, and *R. fullonica*, the elements are in the form of disks. In the three exceptions the elements are more or less cup-shaped. In *R. radiata*, as described in a former paper, they are in the form of thick-walled shallow cups. The electric plate, apparently a greatly enlarged motor plate, lines the cup, which throughout resembles an ordinary striated muscle. In *R. circularis*, a more specialized member of the group, the electric elements are larger and better developed. The cups are deep and well moulded, and the electric layer is even more complex than in *R. batis*; at least, it more closely resembles the electric layer of the torpedo. Further, the cups are invested by a thick nucleated cortex, from which a number of delicate short processes project—the first appearance of the long prongs found in *R. batis*. In *R. fullonica* the electric elements stand nearly midway between the only partially transformed muscular fibres of *R. radiata* and the complex disks of *R. batis*. The cups in *R. fullonica* are less deep than in *R. circularis*; and while the electric and striated layers appear to be all identical in the two species, the cortex is decidedly more like that of *R. batis*. The short simple processes of *R. circularis* are represented in *R. fullonica* by processes, often complex, which, by projecting freely from the outer surface of the cup, give it an irregular villous appearance, and at once suggest the processes or prongs which are so characteristic of the alveolar layer of *R. batis*.

After giving a summary of his observations on the electric organ of the skate, the author concludes by pointing out that it is not yet possible to indicate by what method the electric organs of fishes have been produced.

“On the Organization of the Fossil Plants of the Coal-Measures. Part XIX.” By W. C. Williamson, LL.D., F.R.S., Professor of Botany in the Owens College, Manchester.

Physical Society, February 12.—Annual General Meeting.—Prof. W. E. Ayrton, F.R.S., President, in the chair.—The Report of the Council was read by the President, as were also the obituary notices of Prof. W. Weber, late Honorary Member, Mr. W. G. Gregory, and Prof. James Couch Adams. A list of additions to the library accompanied the Report. Dr. E. Atkinson read the Treasurer's statement, showing a gain of about £240. On the motion of the President, the Reports of the Council and of the Treasurer were unanimously adopted. Prof. Van der Waals was elected an Honorary Member of the Society. Prof. Reinold proposed a cordial vote of thanks to the Lords of the Committee of Council on Education for the use of the rooms and apparatus in the Royal College of Science. This was seconded by Prof. S. P. Thompson, and carried unanimously. A similar vote was accorded to the auditors, Dr. Fison and Mr. H. M. Elder, on the motion of Mr. W. Baily, seconded by Dr. C. V. Burton. The following gentlemen were declared duly elected to form the new Council:—President: Prof. G. F. Fitzgerald, F.R.S. Vice-Presidents: Prof. A. W. Rucker, F.R.S., Walter Baily, Prof. O. J. Lodge, F.R.S., Prof. S. P. Thompson, F.R.S. Secretaries: Prof. J. Perry, F.R.S., and T. H. Blakesley. Treasurer: Dr. E. Atkinson. Demonstrator: C. Vernon Boys, F.R.S. Other Members of Council: Shelford Bidwell, F.R.S., Dr. W. E. Sumpner, Major-General E. R. Festing, R.E., F.R.S., J. Swinburne, Prof. J. V. Jones, Rev. P. J. Smith, Prof. W. Stroud, L. Fletcher, F.R.S., G. M. Whipple, James Wimshurst. A vote of thanks to the officers of the Society was proposed by Mr. Swinburne, seconded by Mr. A. P. Trotter, and carried unanimously. The Chairman then invited suggestions towards improving the working of the Society. In response, Prof. S. P. Thompson said that as the Society had been established fifteen or sixteen years, and had amply justified its existence, the time had now arrived for giving fuller recognition to the privileges of members. He thought they had earned the right to be called “Fellows,” and that this ought to be signified by some distinctive title. Mr. J. Swinburne suggested that before papers were brought before the meetings they should be read by a Member of Council. If suitable, they should then be printed, and proofs sent to members who

applied for them. Mathematical papers could then be taken as read; and the discussions would be more interesting and to the point. It would also be an advantage if communications on kindred subjects could be taken the same day, and discussed together. Papers on purely technical subjects should go to the technical societies. Prof. Ayrton, in reply to Mr. Swinburne, said the members had the matter of papers in their own hands, for, as pointed out in the Report of the Council, if they would only send in the papers early enough, the Secretaries would be glad to group them in the way suggested. Referring to Prof. Thompson's remarks, he said he had often thought it would be an advantage to have another class of members in the shape of “Students,” who should hold meetings amongst themselves. Mr. A. P. Trotter said the Society was unique in many respects, and thought it was not desirable to have different grades of membership. Dr. C. V. Burton agreed with Mr. Trotter, and said that even if Prof. Thompson's suggestion was adopted, means should be provided that persons could be admitted into the Society without claiming any distinction therefrom. Prof. S. P. Thompson, referring to the communications brought before the Society, said it was not necessary that all should possess great novelty. Descriptions of new arrangements of apparatus, of diagrams, and exhibits of modern instruments were of great interest to members. The Chairman pointed out that at the early meetings of the Society exhibitions of instruments were frequent, and said the Council would be glad if instrument makers would send apparatus to be shown at any of the meetings.—The meeting was resolved into an ordinary science meeting, and Messrs. W. R. Bower and E. Edsen were elected members.—Prof. S. P. Thompson, F.R.S., communicated a note on supplementary colours, and showed experiments on the subject. As white light can be divided into pairs of “complementary colours,” so any coloured light, not monochromatic, can be split up into pairs of tints; these, the author, for want of a better name, has called “supplementary colours.” For producing such colours two methods were used. In the first one, a spectrum of the coloured light was formed by a direct-vision spectroscopic and recombined on a screen. By interposing a narrow prism between the spectroscopic and screen, a portion of the spectrum was separated from the rest, and various pairs of supplementary colours thereby obtained. In the other method, polarized light, a quartz plate, and a double image prism were used to form two patches of complementary colours. On interposing a coloured medium the patches became supplementary, and varied in tint as the prism was rotated. The chief peculiarity of supplementary colours was the great variety of tints that could be obtained from a single medium, permanganate of potash in dilute solutions being particularly rich in this respect. The author had also noticed that the eye was not very sensitive to orange-coloured rays. When experimenting by the second method, he had observed that with any composite light one of the supplementary patches could be got of a grayish hue, and the other nearly a pure spectrum tint. He thus unexpectedly verified Abney's law that any colour could be produced by diluting some spectrum tint with white light. Captain Abney said it was very interesting to see the gray colour and the supplementary colours shown by the author. General Festing and himself had experimented on colour phenomena by methods quite different from those used by Prof. Thompson, for they had matched colours by adding white light to pure spectrum tints until a match was produced. Greater purity of colour could be obtained in this way.—A paper on modes of representing electromotive forces and currents in diagrams, by Prof. S. P. Thompson, F.R.S., was postponed.

Chemical Society, February 18.—Prof. W. A. Tilden, F.R.S., Vice-President, in the chair.—The following papers were read:—A search for a cellulose-dissolving (cytolytic) enzyme in the digestive tract of certain grain-feeding animals, by H. T. Brown. The author and G. H. Morris have recently shown that during germination of grass-seeds the cell-membrane of the endosperm is broken down and destroyed by a specific cellulose-dissolving enzyme, or cytolytolyd; such disintegration of the cell-wall being a necessary operation, as otherwise the cell-contents would not readily come under the influence of the very indiffusible starch and proteid-dissolving enzymes secreted by a certain layer of cells in the embryo. As it was found by the author that the analogous starch-hydrolyzing enzymes of animal saliva and of the pancreatic secretion experiences the same difficulty in traversing the thin cell-mem-

brane, it appeared almost certain that grain-feeding animals must possess some provision in their economy for removing, during digestion, the walls of the starch-cells of the interior of the grain, in order that the cell-contents may be accessible to the digestive enzymes of the alimentary canal. This is, however, found to be not the case. The cell-wall is completely dissolved before the grain food enters the small intestine, but the enzyme effecting the dissolution is not secreted by any part of the animal economy, but is pre-existent in the grain before ingestion. The comparative abundance of the cytohydrolyst in the various grain foods given to stock is, as will be at once seen, of great importance, bearing as it does on the relative speed of digestion. Thus, oats contain a particularly large proportion of the cytohydrolyst; this fact throws considerable light on the cause of the high estimation in which oats are held as a food-stuff.—On the influence of oxygen and concentration on fermentation, by A. J. Brown. The author describes experiments on the reproductive power of yeast, from which it appears that all fermentable nutritive solutions encourage the increase in number of yeast-cells to some fixed point, beyond which they will not reproduce themselves. It is also shown that if a greater number of cells be introduced into a fermentable solution than the liquid could originally develop, no increase in the number of the cells takes place. As under conditions like these fermentation still proceeds vigorously, a number of disturbing factors which complicate the results obtained under ordinary conditions may be eliminated by using non-multiplying yeast-cells. By experimenting with a fixed number of cells, it is found that the presence of oxygen exercises an accelerating influence on the speed of fermentation by means of yeast. This fact seems irreconcilable with Pasteur's theory of fermentation. The author also finds that the speed of fermentation of sugar is not dependent on the concentration of the solution, but that, in solutions containing between 5 and 20 per cent. of dextrose, approximately the same weight of sugar is fermented in equal times. When the amount of dextrose in the solution reaches 30 per cent., fermentation proceeds much more slowly.—Limetlin, by W. A. Tilden. Limetlin,  $C_{11}H_{10}O_4$ , is a crystalline substance deposited from the essential oil of the lime. It forms very pale yellow, thin prisms which melt at  $147^{\circ}5$ . Dilute solutions exhibit a beautiful violet fluorescence. It yields a dibromo-derivative,  $C_{11}H_8Br_2O_4$ , a trichloro-compound,  $C_{11}H_7Cl_3O_4$ , and a dibromochloro-derivative,  $C_{11}H_7Br_2ClO_4$ . Nitric acid converts it into a nitro-derivative,  $C_{11}H_9(NO_2)O_4$ . On fusion with potash it yields phloroglucinol and acetic acid. It seems to have the constitution  $C_6H_2(OCH_3)_2 \cdot C_5HO_2$ .—The acid action of drawing-papers, by C. Beadle. Prof. Hartley has recently shown that drawing papers possess an acid reaction, and considers the acidity to be due to sulphuric acid left in the fibre after the processes of souring and washing in the manufacture of the paper. Drawing-papers are sized with gelatin and alum, and it is to this latter substance that the author attributes the acid reaction. The aqueous extract from one of these papers was found to react acid towards litmus solution, but basic towards methyl orange. The apparent acidity of the extract is hence due to the presence of a basic sulphate of alumina.

**Geological Society, February 10.**—Sir Archibald Geikie, F.R.S., President, in the chair.—The following communications were read:—The raised beaches, and "head" or rubble drift of the South of England: their relation to the valley drifts and to the Glacial period; and on a late Post-Glacial submergence, Part I., by Joseph Prestwich, F.R.S. The author remarks that, besides the subaerial, fluvialite, and marine drifts of the south of England, there is another drift which is yet unplaced. This he considers to be connected with the "head" overlying the raised beaches. Of these he describes the distribution, characters, and relations along the south coast. The "head" overlies the beaches, and frequently overlaps them. In the beaches large boulders are found, and marine shells, of which lists for the various localities are given. The "head" frequently shows rough stratification of finer and coarser materials. It contains mammalian bones, land-shells only, and occasionally flint implements. On the coasts of Devon and Cornwall it is separated from the raised beaches by old sandunes. In South Wales the beach occurs below the mammaliferous cave-deposits, whilst material corresponding to the "head" seals up the cave-mouths. The ossiferous breccias of the caves are therefore intermediate in age between the beaches and the "head." The origin of the boulders is discussed, and

it is inferred that they have been brought, not from the French coast, nor from a submerged land, but from a north-easterly source by floating ice through the Straits of Dover. The Mollusca of the raised beaches, of which a list of 64 is given, are closely related to forms living in the neighbouring seas. These raised beaches are not of the age of the higher valley-gravels; but the evidence (especially that yielded by the Somme Valley deposits) points rather to their connection with the lower valley-gravels, and therefore, with the exception of the caves, they represent the latest phase of the Glacial period. After the reading of the paper, the President thought the Fellows were to be congratulated that the father of the Society should still continue to furnish them with such papers as that to which they had listened—so full of careful observation, ranging over so wide an area, and raising so many questions of the greatest interest. They would regret that the author was prevented by illness from being present that evening, but he hoped that he would be able to attend when the second part of the paper was read, and when the full discussion of this wide subject could be entered upon. Dr. Evans concurred in the advisability of postponing the discussion of the paper until the second part had been read.—The *Olenellus* zone in the North-West Highlands, by B. N. Peach and J. Horne. (Communicated by permission of the Director-General of the Geological Survey.) In the stratigraphical portion of this paper brief descriptions are given of certain sections in the Dundonnell Forest, from eight to ten miles north-north-east of Loch Maree, which have yielded fragments of *Olenellus*. The organisms are embedded in dark blue shales occurring near the top of the "fucoid beds" and towards the base of the "serpulite grit," forming part of the belt of fossiliferous strata stretching continuously from Loch Erriboll to Strome Ferry—a distance of ninety miles. In the Dundonnell Forest the basal quartzites rest with a marked unconformability on the Torridon Sandstone. There is an unbroken sequence in certain sections from the base of the quartzites either to the "serpulite grit" or to the lowest bands of the Durness limestone. At these horizons the strata are truncated by a powerful thrust, which, at Loch Nid, brings forward a slice of Archaean rocks with the Torridon sandstone and basal quartzite. The strata from the base of the quartzites to the base of the Durness limestone, exposed in the Dundonnell Forest, are compared with their prolongations to the north and south of that region, from which it appears that there is a remarkable persistence of the various subzones identified in Assynt and at Loch Erriboll. But between Little Loch Broom and Loch Kishorn dark blue shales near the top of the "fucoid beds" have been observed at various localities, evidently occupying the same horizon as the *Olenellus* shales in the Dundonnell Forest. The serpulites (*Salterella*) associated with the trilobites in the "serpulite grit" occur in the basal bands of the overlying limestone; they were found during last season in the brown dolomitic shales accompanying the *Olenellus* shales in the "fucoid beds," and they were formerly detected in the third subzone of the "pipe-rock" in Sutherland. Their appearance on these horizons leads us to cherish the hope that portions of *Olenellus* may yet be met with in certain shales in the quartzites, and probably in the lowest group of limestone. The evidence now adduced proves (1) that the "fucoid beds" and "serpulite grit" are of Lower Cambrian age, the underlying quartzites forming the sandy base of the system; (2) that the Torridon Sandstone, which is everywhere separated from the overlying quartzites by a marked unconformability, is pre-Cambrian. The *Olenellus* which has been discovered is described as a new species (*O. Lapworthi*) closely allied to *O. Thompsoni*, Hall, from which it differs chiefly in the arrangement of the glabella-furrows, and in the presence of a rudimentary mesial spine at the posterior margin of the carapace. Remains of other species referable to *Olenellus* are described, but these are too fragmentary for exact determination. All are characterized by a reticulate ornamentation similar to that described by Walcott in *O. (Mesonacis) asaphoides*, Emmons. The remains consist chiefly of portions of carapaces. The reading of this paper was followed by a discussion, in which Dr. Hicks, Dr. Woodward, the President, Prof. Lapworth, and Mr. Peach took part.

February 24.—W. H. Hudleston, F.R.S., President, in the chair.—The following communications were read:—The raised beaches, and "head," or rubble-drift, of the South of England: their relation to the valley-drifts and to the Glacial period; and on a late post-Glacial submergence, Part II., by Joseph Prestwich, F.R.S. The ossiferous deposits

of the Caves of Gower are shown to be contemporaneous with the raised sand-dunes between the beaches and the "head," and reasons are given for supposing that the elevation of land which preceded their formation need not necessarily have been greater than 120 feet. The mammalian fauna of these caves is the last fauna of the Glacial or post-Glacial period, and the "head" or rubble-drift marks the closing chapter of Glacial times. Evidence is given for considering that the "rubble-drift" has a wide inland range, and that to it are to be referred the "head" of De la Beche, the subaerial detritus of Godwin-Austen, the angular flint drift of Murchison, and in part the "trail" of Fisher and the "warp" of Trimmer, as well as other deposits described by the author. The accumulation is widespread over the south of England, and occurs in the Thames Valley, on the Cotteswold Hills, and on the flanks of the Malverns. The stream-tin detritus of Cornwall and the ossiferous breccia filling fissures (which must be distinguished from the ossiferous deposits of the true caves) are held to be representatives of the "rubble-drift," which is of a variable character. The author discusses the views of previous writers on the origin of the accumulations which he classes together as "rubble-drift," and points out objections to the various views. He considers that they were formed on upheaval after a period of submergence which took place slowly and tolerably uniformly; and that the absence of marine remains and sedimentation shows the submergence to have been short. This submergence cannot have been less than 1000 feet below present sea-level, and was shortly brought to a termination by a series of intermittent uplifts, of which the "head" affords a measure, sufficiently rapid to produce currents radiating from the higher parts of the country, causing the spread of the surface-detritus from various local centres of higher ground. The remains of the land animals killed during the submergence were swept with this debris into the hollows and fissures on the surface, and finally over the old cliffs to the sea- and valley-levels. Simultaneously with this elevation occurred a marked change of climate, and the temperature approached that of the present day. The formation of the "head" was followed in immediate succession by the accumulation of recent alluvial deposits; so that the Glacial times came, geologically speaking, to within a measurable distance of our own times, the transition being short and almost abrupt. In this paper only the area in which the evidence is most complete is described. The author has, however, corroborative evidence of submergence on the other side of the Channel.—The Pleistocene deposits of the Sussex coast, and their equivalents in other districts, by Clement Reid. (Communicated by permission of the Director-General of the Geological Survey.) The gales of last autumn and early winter exposed sections such as had not before been visible in the Selsey Peninsula. Numerous large erratic blocks were discovered, sunk in pits in the Bracklesham Beds. These erratics included characteristic rocks from the Isle of Wight. The gravel with erratics is older, not newer as is commonly stated, than the Selsey "mud-deposit" with southern Mollusca. Numerous re-deposited erratics are found in the mud-deposit, which is divisible into two stages—a lower, purely marine, and an upper, or *Scrobicularia*-mud, with acorns and estuarine shells. At West Wittering a fluviatile deposit, with erratics at its base and stony loam above, is apparently closely allied to the mud-deposit of Selsey; it yields numerous plants, land and fresh-water Mollusca, and mammalian bones, of which lists are given. The strata between the brick-earth (= Coombe Rock) and the gravel with large erratics yield southern plants and animals, and seem to have been laid down during a mild or interglacial episode. A similar succession is found in the Thames Valley and in various parts of our eastern counties. After the reading of these papers there was a discussion, in which the President, Dr. Evans, Mr. Ussher, Mr. J. Allen Brown, Prof. Hughes, Dr. Hicks, and others took part.

**Linnean Society, February 18.**—Prof. Stewart, President, in the chair.—The President exhibited specimens of *Cystocalia immaculata*, an orthopterous insect from Namaqualand, in which the female is far more conspicuously coloured than the male (which is unusual), and the stridulating apparatus of the male differs in certain important details from that of other species. A discussion followed on stridulation in insects and the various modes of producing it, in which Messrs. C. Breeze, E. M. Holmes, and B. Daydon Jackson took part.—The President also exhibited some specimens of a Crustacean, *Ocyropa ceratophthalma*, and communicated some interesting information thereon.—A paper by Prof. Groom was then read, on bud-

protection in Dicotyledons, and, in his unavoidable absence, the author's views were expounded by Mr. B. Daydon Jackson.—Mr. W. T. Thistelton-Dyer, C.M.G., F.R.S., communicated a paper by Herr F. Stephani, entitled "A Revision of Colenso's New Zealand *Hepatica*."

**Entomological Society, February 24.**—Mr. Frederick Du-Cane Godman, F.R.S., President, in the chair. The President referred to the loss the Society had recently sustained by the death of Mr. Henry Walter Bates, F.R.S., who had twice been its President; and he also read a copy of the resolution of sympathy and condolence with Mrs. Bates and her family, in their bereavement, which had been passed by the Council at their meeting that evening.—Mr. Frederick C. Adams exhibited a monstrous specimen of *Telephorus rusticus*, taken in the New Forest, in which the left mesothoracic leg consisted of three distinct femora, tibiae, and tarsi, apparently originating from a single coxa. He also exhibited specimens of *Lebra aurita*.—Mr. G. A. James Rothney sent for exhibition a series of specimens of two species of Indian ants (*Myrmecaria subcarinata*, Sm., and *Aphenogaster (Messor) barbarus*, L., var. *punctatus*, Forel) which had recently been determined for him by Dr. Forel. He also communicated notes on the subject, in which it was stated that *Myrmecaria subcarinata*, Sm., was not uncommon in Bengal, and formed its nest by excavating the earth round trees, and throwing it up in mounds of fine grains. The author also stated that both sexes of this species swarmed early in the "rains," from about July 7 to July 10. Of the second species—*Aphenogaster barbarus* var. *punctatus*, Forel.—Mr. Rothney observed that it, like the bee, *Apis dorsata*, seemed to have a great partiality for the gardens and buildings of the old Mogul Emperors in the North-West Provinces and in the Punjab, the bee disfiguring the arches and roofs with its huge nests, and the ant frequenting the gardens and steps.—The Hon. Walter Rothschild communicated a paper entitled "On a Little-known Species of *Papilio* from the Island of Lifu, Loyalty Group." The paper was illustrated by a beautifully coloured drawing of the male, variety of the male, female, and under side of the species.

#### EDINBURGH.

**Royal Society, February 15.**—Sir W. Turner, Vice-President, in the chair.—The Astronomer-Royal for Scotland read a paper on the new star in the constellation Auriga discovered recently by the Rev. Dr. T. Anderson, of Edinburgh. Dr. Anderson believes that he first saw the new star on January 24, but he did not recognize it as new until a few days later, when it struck him that its right ascension did not agree with that of 26 Auriga, for which he had mistaken it. When the Astronomer-Royal first examined the spectrum in the beginning of this month, its general appearance was that presented by new stars soon after their first outburst. Since then the spectrum has gradually become more continuous. Only one of the characteristic nebular lines (F) was present. Two other lines nearly coincide with characteristic nebular lines; but one has too great, the other too small, refrangibility, so that the displacement cannot be due to motion of the star, even if it had not been (as it is) too great a displacement to admit of probable explanation in this way. The brightness of the star increased gradually after its first observation, then decreased more rapidly, and finally became nearly steady. The brightness of new stars usually increases rapidly at first, and finally diminishes gradually to zero. The general phenomena presented in the present case resemble those of a variable star, such as R Andromedae or R Cygni, rather than those of a new star which rapidly burns out.—Sir W. Turner read a paper on the lesser orquial (*Balanoptera rostrata*) in the Scottish seas. After giving a brief account of the occurrence of this whale in Scottish seas, Sir W. Turner proceeded to discuss the specimen which was captured near Granton, in the Firth of Forth, in 1888. The lesser orquial is characterized externally by a dorsal fin, by a large white patch on the front aspect of each flipper, and by great apparent distension anteriorly on the ventral aspect, the distension being prolonged to the extreme anterior end. The whalebone is also characteristic, the extremities of the plates being broken up into thin fibres. The author points out a distinction between whales belonging to the dolphin class and other whales, in respect of the stomach. In the former the first compartment of the stomach does not fulfil a digestive function; in the latter all the compartments have a digestive function. The number of compartments varies from



four in the porpoise to fourteen in Sowerby's whale. The stomach of the lesser porpoise has five compartments, the first of which has not a digestive function, so that in this respect it resembles the dolphin's. The third compartment is very small, its existence being indicated externally only by a faintly marked line on the surface of what seems to be the third, but is really the fourth. The size of the openings connecting the various compartments diminishes rapidly from the anterior to the posterior end.—Prof. Tait read a paper on the relation between kinetic energy and temperature in liquids. He showed how, by considering (in the usual pressure-volume diagram) a Carnot's cycle formed by the horizontal part of an isothermal below the critical temperature, the lines of constant volume passing through the extremities of that part, and the portion of the critical isothermal intercepted between these lines, we can calculate the difference between the average specific heats of the liquid and the vapour at constant volume throughout the given range of temperature in terms of known quantities, the vapour, of course, starting from the condition of saturation at the lower temperature. In this cycle the substance is—except when in the state corresponding to the horizontal part of the lower isothermal—either entirely liquid or entirely vapour. In the case of carbonic acid, it appears that the average specific heat at constant volume throughout a given range is greater in the liquid condition than in the state of vapour. In the liquid state (judging from Amagat's results) the average at constant volume seems to be about equal to the specific heat of the vapour at constant pressure. He gave also a number of thermal details about  $\text{CO}_2$ , mainly based on Amagat's experiments. These included the latent heat of the vapour which (taking the volume of 1 pound of  $\text{CO}_2$  at  $0^\circ\text{C}$ . and 1 atmosphere as 8 cubic feet) was shown to fall from 53 units at  $0^\circ\text{C}$ . to  $17.8$  at  $30^\circ\text{C}$ .

## DUBLIN.

Royal Society, February 17.—The Right Hon. the Earl of Rosse, F.R.S., President, in the chair.—Note on the basal conglomerate of Howth, by Prof. W. J. Sollas, F.R.S. The author discussed the characters of these lowest-lying deposits of the Hill of Howth, and stated that he could find no evidence for the volcanic origin attributed to them by Sir A. Geikie: they had been formed in more than one way; a considerable part arose from the dislocation, fracture, and crushing of the Cambrian slates and quartzites *in situ*, the broken fragments being subsequently rounded by intratelluric flow; but some appeared to be true conglomerates, which had been powerfully affected by crust movements. This is only what one might expect when one considered that from the higher beds of Bray there was an increased development of arenaceous material downwards into the lower beds of Howth: the approximation to a shore indicated by the frequency of sandy shoals, leads at length to an actual beach, indicated by the basal conglomerates.—The variolite of Annalong, Co. Down, by Prof. Grenville A. J. Cole. This rock occurs as a dyke north of Annalong, exposed above low water for about 80 feet, and 4 feet wide. The mass consisted, at the time of its consolidation, of spherulitic tachylyte throughout, being a very remarkable development of basic glass, and probably the crest of an olivine-basalt dyke. The extreme edges still retain their glassy character. In the interior of the devitrified mass the spherulites are 1 cm. in diameter. This is the second recorded occurrence of variolite in the British Isles: a specimen, correctly named, and collected by the Irish Ordnance Survey some fifty years ago, led to the author's search for the rock on the coast of the Co. Down.—Mr. J. Joly read a paper entitled "On a Speculation as to a pre-Material Condition of the Universe."

## OXFORD.

University Junior Scientific Club, February 17.—Mr. J. A. Gardner, of Magdalen College, President, in the chair.—Mr. F. R. L. Wilson, Keble College, exhibited some Telugu Palmyra-leaf manuscripts from the north-east of the Madras Presidency.—Mr. H. H. G. Knapp, Non-Coll., read a paper on muscular fatigue. A discussion followed, in which various members took part.—A paper was read by Mr. R. E. Hughes, Jesus College, on the nature of solution. A lengthy discussion followed this paper.

## CAMBRIDGE.

Philosophical Society, February 8.—Prof. Darwin, President, in the chair.—The following communications were made:—

NO. 1167, VOL. 45]

On long rotating circular cylinders, by C. Chree, Fellow of King's College. A solution is found for a long cylinder of isotropic elastic material, with its cross-section bounded by a circle or by two concentric circles, rotating with uniform velocity about its axis. The solution is not exact, save when Poisson's ratio is zero, but is approximate in the same way as Saint-Venant's solution for beams. Formulæ are given on which are based tables showing the shortening of the cylinder and the increase in its radius or radii under rotation. Formulæ are also found for the limiting safe speeds according to the stress-difference and greatest strain theories, and these are compared with the formulæ arrived at by Prof. Greenhill on his theory of instability. The results appear to be of considerable practical importance.—On the theory of contact and thermo-electricity, by J. Parker, St. John's College. The phenomena are deduced by analytical thermodynamics solely from expressions for the energy and entropy functions of the system. These are of the most general type, in that they include all kinds of terms that are formally possible, the coefficients of these terms being the measures of physical properties of the system which may or may not have an actual existence. Thus there will occur terms which indicate, after Helmholtz, affinity between electricity and different kinds of matter. The results are just sufficiently wide to include the known facts of thermo-electricity. Considerations of a cognate kind have been treated by Lorentz, Duhem, and Planck.

February 22.—Prof. Darwin, President, in the chair.—The following communications were made:—Preliminary notes of some observations on the anatomy and habits of *Alcyonium*, by S. J. Hickson. Between the coelentera of *Alcyonium* there is a dense, transparent gelatinous mesogloea. This is penetrated (1) by endodermal cords connected with the endoderm of the coelentera, and (2) a plexus of very fine nerve (?) fibrils connected with a number of very small uni-, bi-, or tripolar ganglion cells. The endodermal cords are not hollow canals, as they are usually described, and all attempts to inject them failed. At the periphery these endodermal cords come into contact with ectodermal invagination at places between the old polypes, and give rise to the buds. When the young buds have nearly developed all the characters of the older polypes, canals are formed which communicate with the coelentera. The plexus of fine nerve fibrils can only be made out in fresh specimens stained with osmic acid. It could not be traced in the peripheral parts of the colony in consequence of the great quantity of the calcareous spicules in this region. Some experiments were made to determine whether in these animals the expansions and contractions of the polypes occur rhythmically. During the first two or three days after *Alcyonium* is placed in the tank it contracts completely with tolerable regularity twice in every twenty-four hours. After that time it either remains expanded or contracts irregularly. Of six *Alcyonium* that were placed in a tank with an artificial tide that rose and fell every twelve hours, only three unfortunately survived for more than a fortnight, and these contracted with tolerable regularity once in twenty-four hours. These experiments seem to prove that *Alcyonium* contracts normally twice in every twenty-four hours, and that the rhythm of these contractions continues for some time after it is removed from the action of the tides, and that a new rhythm may be induced by subjecting them to the action of an artificial tide of a different period.—On the action of lymph in producing intravascular clotting, by Dr. L. E. Shore. The sudden injection into the vascular system of a rabbit of a small quantity (4 c.c. to 15 c.c.) of lymph drawn from the thoracic duct of a dog causes death with more or less complete intravascular clotting. The lymph loses this property after it has itself clotted. The injection of even large quantities of lymph-serum produces no such effect. Protein bodies in the apparently normal lymph to which the power is due have been isolated.—On the fever produced by injection of *Vibrio Metschnikovi*, by E. H. Hankin and A. A. Kanthack.—On the method of fertilization in *Ixora*, by J. C. Willis. The flowers are massed together and thus rendered conspicuous. Honey is secreted by a nectary upon the disk, and protected by the length (3-4 cm.) and narrowness of the tube. The mechanism resembles that of *Campanula*. The anthers dehisce in the bud, covering the style, whose stigmas are closed up with pollen. The stamens bend away when the flower opens, and the style presents the pollen to insects. Later the stigmas separate, but never bend back so far as to effect autogamy. In *I. Westii* autogamy occurs in the bud, but the flower appears to be self-sterile.

## PARIS.

**Academy of Sciences, February 29.**—M. d'Abbadie in the chair.—On a differential equation relating to the calculation of perturbations, by M. F. Tisserand.—On the storm of June 8, 1891, in the Department of Lot-et-Garonne, by M. Faye. The account given in this paper of the circular movements of winds and descending currents supports M. Faye's theory of cyclones.—On the order of appearance of the vessels in the flowers of *Taraxacum dens leonis*, by M. A. Trécul.—Researches on monohalogen and monocyano derivatives of ethyl acetate, by MM. A. Haller and A. Held.—Influence of the intra-renal tension on the functions of the liver, by M. Félix Guyon.—On the fundamentals of geometry, by M. Sophus Lie.—Remarks on the subject of the last communication by M. Gouy, on the superficial tension of liquid metals, by M. H. Pellat.—On some diffraction experiments, by M. Hurmuzescu.—On the polarization of the atmosphere by the light of the moon, by M. N. Piltchikoff. A series of observations made by means of a polarimeter shows that the proportion of polarized light in the sky at night diminishes in a continuous manner from the time of full moon, when a maximum is attained, to new moon, when it reaches zero; it afterwards increases from new moon to full moon.—On the temperatures of certain industrial furnaces, by M. H. le Chatelier. Measurements of certain high temperatures by the method recently communicated to the Academy have led to results not in accord with previous estimations.—Stereochemistry and the laws of rotary power, by M. Ph. A. Guye. A reply to the notes on this subject by M. Colson.—A series of new compounds: chromosulphuric acid and the metallic chromosulphates, by M. A. Recoura. (See Notes.)—Researches on the application of the measurement of rotary power to the determination of the combinations formed by aqueous solutions of perseite with the acid molybdates of sodium and ammonium, by M. D. Gernez.—Action of soda and potassium cyanide on chlorodiamylamine, by M. A. Berg.—Metaphenyltoluene, by M. G. Perrier.—On the presence of mannite and sorbite in the fruits of the laurel cherry, by MM. Camille Vincent and Delachanal. The authors find these two alcohols present in equal proportions in the fruits of the laurel cherry.—The heats of formation of potassium carbylates, by M. G. Massol. The quantities of heat disengaged by the successive combination of three molecules of potash with one molecule of carbylic acid decrease progressively. The mean heat of combination is superior to that of the monobasic acids. These results are the same as those obtained for simple organic dibasic acids.—Note on the density of textiles, by M. de Chardonnet.—The detection of oil of resin in turpentine, by M. Zune.—Comparative nitrification of humus and unaltered organic matter, and the influence of the proportion of nitrogen in the humus upon the nitrification, by M. B. Pichard.—On the medical utilization of alternating currents of high potential, by MM. G. Gautier and J. Larat. The authors have reduced an electromotive force of 2000 volts, by means of transformers, to a voltage suitable for medical purposes, and have experimented on several patients to determine the influence of alternating currents on nutrition.—On the composition of haemocyanin, by M. A. B. Griffiths. The results of analyses are represented by the formula  $C_{867}H_{1363}N_{223}Cu_5O_{268}$ .—Pto-maines in some infectious disorders, by M. A. B. Griffiths.—The *Molle*, a disease of the *Champignons de Couche*, by MM. Costantin and Dufour.—Spring and autumn woods, by M. Emile Mer.—On fecundation in cases of polyembryony, by M. G. Chauveaud.—On the action of the *nucleole* on the turbulence of the cell, by M. Ch. Decagny.—On the regimen of subterranean waters in the Upper Sahara of the province of Algiers, between Laghouat and El Golea, by M. Georges Rolland.

## BERLIN.

**Physical Society, February 12.**—Prof. Kundt, President, in the chair.—Dr. Kalischer showed how, without using Kirchoff's law, the distribution of currents in a system of linear conductors may be calculated in a very simple manner by employing the once much-used but recently neglected principle of the superposition of currents.—Dr. E. Budde gave an exact definition of "temperature" on the basis of mathematical deductions and of physical considerations.

**Physiological Society, February 19.**—Prof. Munk, President, in the chair.—Dr. Katzenstein has satisfied himself, on the basis of careful anatomical and physiological investigation, that the crico-thyroid muscle is innervated by the inferior laryngeal nerve, a conclusion also arrived at by Prof. Zuntz.

**Physical Society, February 26.**—Prof. Kundt, President, in the chair.—Prof. Neesen gave an account of measurements of latent heats of evaporation which he had determined by means of a condensation-calorimeter. In these experiments a small quantity of the fluid under investigation was allowed to evaporate *in vacuo* for one or two minutes while resting on the surface of mercury in such a way as not to be in contact with the walls of the containing vessel. Pure water gave a latent heat of evaporation which corresponded closely with that obtained by Regnault. Dilute solution of sodium chloride (one molecule of the salt per litre of water) gave a result which was nearly the same as for water, but slightly greater. As the percentage of salt in solution was increased (up to four molecules per litre) the latent heat of evaporation rapidly diminished. A series of alcohols have similarly been examined, but the values for these not yet accurately determined. It was found that in general the latent heat of evaporation is greater during rapid than during slow evaporation. The condensation of the vapours on the walls of the vacuum space was recorded by the movement of the calorimeter scale.—Dr. Thiesen spoke on the properties of perfect dioptric systems, as based upon certain mathematical deductions, and on the construction of systems with any given properties.

## BOOKS RECEIVED.

Our Trees: J. Robinson (Salem, Horton).—An Advanced Class-book or Modern Geography: W. Hughes and J. F. Williams (Phillip).—The New University for London: Prof. K. Pearson (Unwin).—Marriage and Disease: Dr. S. A. K. Strahan (Kegan Paul).—A Study of Influenza, and the Laws of England concerning Infectious Diseases: Dr. R. Sisley (Longmans).—The Naturalist in La Plata: W. H. Hudson (Chapman and Hall).—The Elements of Plane Trigonometry: R. Levett and C. Davison (Macmillan).—The Grammar of Science: Prof. K. Pearson (Scott).—Homologies of Science: Dr. P. Carus (Arnold).—Chemical Calculations: R. L. Whiteley (Longmans).—Thoughts and Reflections of the late David Terius (Gabriel (Unwin).—Text book of Psychology: W. James (Macmillan).—Mathematical Recreations and Problems: W. W. R. Ball (Macmillan).—Palaeontological Society, vol. xiv. (London).—Things Japanese, and edition: B. H. Chamberlain (Kegan Paul).—Bulletin of the U.S. Geological Survey, Nos. 62, 65, 67 to 82 (Washington).—Universal Atlas, Part 12 (Cassell).—The Iford Manual of Photography: C. H. Bothamley (Iford).

## CONTENTS.

	PAGE
The Science Museum and the Tate Gallery . . . . .	433
The Correspondence of Christian Huygens. By A. M. Clerke . . . . .	434
The Horse. By C. Ll. M. . . . .	436
Our Book Shelf:—	
Taylor: "A System of Sight-Singing from the Established Musical Notation, based on the Principle of Tonic Relation" . . . . .	437
Keltie: "The Statesman's Year-book for the Year 1892" . . . . .	437
Bothamley: "The Optical Lantern as an Aid in Teaching."—W. . . . .	437
Letters to the Editor:—	
Heat-Engines and Saline Solutions.—Lord Rayleigh, Sec. R.S. . . . .	438
Superheated Steam.—John Gamgee . . . . .	438
Poincaré's "Thermodynamics."—P. G. T. . . . .	439
The Function of a University.—Prof. W. E. Ayrton, F.R.S. . . . .	439
Sir R. Ball's "Cause of an Ice Age."—Henry H. Howorth, M.P. . . . .	440
The University of London.—Prof. W. F. R. Weldon, F.R.S. . . . .	440
The Aneroid in Hypsometry.—Herbert Tomlinson, F.R.S. . . . .	440
Sparrows and Crocuses.—R. McLachlan, F.R.S. . . . .	441
A Possible Misunderstanding.—Thomas H. Blakesley . . . . .	441
Hermann Kopp. By Prof. T. E. Thorpe, F.R.S. . . . .	441
Notes . . . . .	443
Our Astronomical Column:—	
Cordova Observatory . . . . .	446
Algol . . . . .	446
The Sun-spots of February . . . . .	446
A New Comet . . . . .	446
Phosphorus Oxide. (Illustrated.) By A. E. Tutton . . . . .	446
University and Educational Intelligence . . . . .	449
Scientific Serials . . . . .	450
Societies and Academies . . . . .	451
Books Received . . . . .	456

THURSDAY, MARCH 17, 1892.

## MAN IN NATURE.

*L'Homme dans la Nature.* Par Paul Topinard. (Paris: Baillière et Cie., 1891.)

IT is with much pleasure that we announce the appearance of a new work from the pen of Dr. Paul Topinard, formerly General Secretary of the Anthropological Society of Paris, and Professor in the *École d'Anthropologie*. Dr. Topinard is well known in this country as one of the most eminent, if not the most eminent, physical anthropologist in France at the present day, and it is with much regret that anthropologists here have observed the shameful way he has been treated by a faction of the Anthropological Society of Paris, who have done their best to diminish his usefulness and retard the advancement of true anthropological science in Paris. Notwithstanding the troubles and anxieties he has gone through—to which we would not have alluded here had they not been public property, and discussed in French scientific journals—it is gratifying to find that Dr. Topinard has pursued the even tenor of his way, and been able to enrich anthropological science by another of his valuable works, forming the seventy-third volume of the "International Scientific Series."

The work under review is divided into twenty-two chapters. The first contains, in addition to a statement of the scope of the book, a short but interesting history of the development of anthropological science. In the second chapter, its nature, its proper limits, and its relation to biology, ethnology, psychology, and sociology, are pointed out. The term "anthropology" is restricted to the study of man as an animal and a member of a group in the zoological series, in conformity with the acceptance in which it is used by Blumenbach, Broca, Quatrefages, and others. In the third chapter, the various subjects of study included in anthropology, as above restricted, are set forth, and the general principles of zoology on which the distribution of animals in groups of different values rests, the choice of characters on which they are founded, and the differences between race, species, family, and order are indicated.

The methods employed in anthropological research are considered in the fifth chapter. These may be briefly stated as descriptive and anthropometric. As descriptive terms are liable to vary very considerably according to the ideas of different observers, their value has hitherto been much less definite than characters based upon measurement. For some time past the author has been endeavouring to elaborate a system of observation which will render descriptive characters more uniform and trustworthy than heretofore. Having had some practical experience of the plan advocated by Dr. Topinard, we may state that we have been favourably impressed with it, not only for producing more uniform results, but also for saving labour to the observer, facilitating the analyses of observations, and for classifying the latter according to their type.

The character of the hair is dealt with in the sixth chapter. The hair is shown to furnish us with characters which are of importance not only in distinguishing races,

but also in comparing man with the animals most nearly allied to him. The author shows that, in respect to their hair, the negro races differ most from the monkeys, while the white races most nearly resemble them, the yellow races being intermediate. In the straight-haired races the hair corresponding to the long coarse outer fur of mammals displaces the woolly hair—the homologue of the woolly under-fur; while in the woolly-haired races the reverse takes place. These characters of the hair would have formed an impassable gulf between the yellow and negro races had not some intermediate forms fortunately been left. The abundant generalization of fur as *lanugo* in the fœtus would go to prove that man descended from a furred progenitor.

The value of statistical maps is discussed in the seventh chapter, and as an example of their use in tracing race-characters, the distribution of the blonde and dark types in France has been taken and illustrated. It is shown, however, that the combination of the descriptive and anthropometric methods gives the most trustworthy results in determining the natural types of man. The latter method is discussed in chapter viii., and the use of indices, projections, seriations, graphic curves, averages, &c., are also explained.

The ninth chapter deals with measurements of the skeleton and the living body, and how these should be made by travellers and others. The directions given for the measurement of the long bones by ascertaining their maximum length is undoubtedly the best method. The proportions which these bones bear to the height of the skeleton (the latter being taken as 100) he gives as follows: humerus 20.0, radius 14.3, femur 27.3, tibia 22.1. To get the stature of the subject when alive, he adds 35 mm. to the height of the skeleton obtained from the detached bones by the above formula. The proportions just mentioned correspond very closely to those of the second series of French skeletons given in the "Éléments d'Anthropologie," and also with Rollet's important observations. Our own observations on subjects which have been carefully measured before dissection, go to support those of Rollet, and to show that the formulæ above given indicate the actual stature as nearly as possible, without adding 35 mm., as Dr. Topinard does. This is probably due to difference in mounting the skeletons—a fertile source of error. We are of the opinion that where it is not possible to get measurements of subjects before dissection in sufficient numbers to establish the formula for the race, it is more trustworthy to do so from the mean stature of the living, than from the height of articulated skeletons. The directions given for measuring the living body and tabulating its descriptive characters, are specially arranged for the purpose of encouraging travellers to undertake anthropometric observations. A model schedule of observations is given, arranged so that the various questions may be answered by a figure or a measurement, which should prove valuable to travellers. The system of measuring the body aimed at in it is to obtain the relative proportions of the several parts, rather than absolute anatomical dimensions; in other words, the author's idea is that it is better that travellers who are not anthropologists, and consequently not trained to anthropological research, should confine their attention to obtaining such measurements as will enable the canon

of proportion of the several parts of the body to be made out, and compared in different races to that which obtains in Europeans, rather than attempt to do work which requires previous anatomical knowledge. The measurements are divided into two classes, according to their importance, but all of them are such as any intelligent traveller, with a little practice, should be able to make with accuracy.

Chapters x. and xi. are devoted to the study of the skull and the head of the living subject. A list of the chief measurements of the skull which the author recommends is given. These are to our mind much more satisfactory than any previous list he has produced, and will, we feel certain, be hailed with pleasure by anthropologists in this country, as being quite in accord with their ideas of what the essential measurements of the skull are. This list also agrees more nearly with the measurements used by our fellow-workers in Germany and Austria; indeed, we might even go so far as to say that when an international system of measuring the skull s arrived at (a time which we hope is not far distant), the difference between it and that now propounded by Dr. Topinard will be slight. The most important measurements of the living head, he considers, are those of the nose, and next to them the diameters of the head. As an example of what may be learned from a single craniometric character when systematically studied, the cephalic index is selected, and he alludes with satisfaction to the international agreement recently arrived at regarding the measurements from which it is obtained and its divisions, and shows that it is a character of the first importance for distinguishing types of races.

Having thus prepared the way, he next discusses the connection between man and the animals which approach nearest to him, the distance which separates them, and the relative place which man occupies amongst them. This naturally leads him to the consideration of the characters and descriptive morphology of the Primates. As the subject is a very wide one, he has restricted his investigation to a comparative study of the brain and the skeleton. Chapters xiii. and xiv. are occupied with the evolution of the brain in the vertebrate series, the form and volume of that organ, and the arrangement of its convolutions. The mechanism of the evolutionary transformation of the cranium of the animal into that of man is traced in the fifteenth chapter, and the craniometric characters connected with this transformation are dealt with in the succeeding chapter. The characters of the head, the vertebral column, the thorax and pelvis connected with the quadrupedal and bipedal attitude, are discussed in the seventeenth chapter, and those relating to the attitude of the body and the function of prehension in the eighteenth.

The nineteenth chapter is devoted to the zoometric characters related to the adaptations of the limbs for prehension and locomotion; the muscular and visceral characters connected with attitude are also discussed shortly. Other characters distinctive of man, the anthropoids, and the monkeys, in the vertebræ, the sacrum, mandible, teeth, liver, &c., are pointed out in the twentieth chapter. Retrogressive anomalies, or the accidental appearance in man and other animals of morphological arrangements foreign to the type, but resembling those

which occur normally in some other type of animal; rudimentary organs, absolutely useless to man, but which are more or less developed in other animals; and progressive anomalies, are the subject of the twenty-first chapter.

The author concludes his task by devoting the last chapter to a *résumé* of the previous chapters. He classifies the Primates as follows:—

- |                           |   |
|---------------------------|---|
| 1st Sub-order—Man.        |   |
| 2nd Sub-order—The Monkeys | (1st family, Anthropoids.<br>2nd " Pitheciadæ.<br>3rd " Cebidæ.<br>4th " Arctopitheciadæ. |
| 3rd Sub-order—The Lemurs. |   |

Supposing the distance between the Cebidæ and the Pitheciadæ to be 1, that between the latter and the Anthropoids would also be 1, while the distance between the Anthropoids alone, or in conjunction with the other two families, on the one hand, and man on the other, would be represented by 3; the same figure would also represent the distance of the lemurs from the monkeys. We note that Dr. Topinard includes Galeopithecus among the lemurs, although this genus is now accepted by zoologists as belonging to the Insectivora, but this slight error is immaterial.

The important subject of the relationship and descent of man is dealt with more briefly than we could have wished. He shows that man cannot be descended from an Anthropoid, which is essentially a perfected and specialized monkey, and that we must look to a lower source for the origin of the human stem, to one where more generalized conditions obtained; indeed, to a type sufficiently far back in time and low down in the animal series as to be the progenitor of the monkeys and man. The beginning of the Miocene period is pointed out as a very remarkable one in the history of the world, during which many of the initial types of our existing genera were formed, and amongst others the first monkey succeeding the lemurs of the preceding Eocene period. It is during this epoch that we must seek for the stem proper of man, and that common to the monkeys, or to both of these sub-orders. According to Cope, man has descended directly from the lemurs, without passing by way of the monkeys and Anthropoids, the lemurs themselves coming through the Marsupials. Beyond this the genealogy of man is merged with that of the Mammalia, of which the first representatives existed as far back as the Trias.

Regarding the question of the unity or plurality of origin of man the author has not very much to say, and although he has reasoned on the assumption of the monophyletic hypothesis of the human species throughout the work—that is to say, that man has originated from a single stem—he considers that there is not sufficient evidence to show clearly one way or other whether this is the case, or that man has a double stem of origin developed during one epoch, or at two epochs separated from one another by a considerable interval of time. This question has yet to be definitely solved with respect to the monkeys, notwithstanding the fact that some American zoologists have shown that the monkeys of the New World have not the same origin as those of the Old World, which, if substantiated, would support the argument of a double cradle of origin for man—namely, according to the

author, one common to Asia and America, the other, situated in some southern continent uniting Africa and Oceania, for the negro.

Whatever the origin of man may have been, the author shows that two periods must be recognized in his history, one before the acquisition of language, which relates to his precursor, and the other after that, during which man properly so-called was constituted.

The author sums up respecting man, the Anthropoids, and the monkeys, by comparing the order of the Primates to a tree. The lemurs are the roots, and give rise to one or several stems. One of these is the stem of the monkeys, a branch of which sends out a bough more elevated than the others—namely, that of the Anthropoids. Another, of which the point of origin or of contact with the former has yet to be discovered, gives off the human branch, which grows up parallel with that of the Anthropoids, but without relation to it, and shoots beyond it.

The book concludes with a few words on the question of whether or not man has attained his perfection. The author's idea is that the volume of the brain cannot increase much more, though it is possible for the anterior lobes to become larger. One thing he thinks is certain, that dolichocephaly will be replaced by universal brachycephaly. Although the brain has probably attained its limits in respect to size, the limits to which the quality of its cells may improve are, as far as can be seen, uncircumscribed, and in this direction man may yet hope to attain to still higher perfection by the development of his intellectual faculties.

From the critical sketch we have given, it will be seen that the book is an important addition to anthropological literature. Not only will it be useful to anthropologists, but also to general readers who desire to obtain an insight into anthropology and to follow what is being done in that science. As an exposition of the subject, we have no hesitation in stating that it is a work of much merit, and worthy of the high reputation of its author. There remains yet the duty to be performed by the publishers, of putting it within the reach of a much wider range of readers than it is accessible to in its present form, by the publication at an early date of the English edition.

J. G. G.

#### FURNITURE WOODS.

*The Art and Craft of Cabinet-making.* By D. Denning. (London: Whittaker and Co., 1891.)

THIS neat little volume purports to be "a practical hand-book to the construction of cabinet furniture, the use of tools, formation of joints, hints on designing and setting out work, veneering, &c., together with a review of the development of furniture." It is well planned, and written in a pleasing and simple style, and appears admirably adapted for its purpose in general.

There is one drawback to this book, common to all works of its kind, and that is the meagre information given in the section dealing with the various kinds of woods employed. These woods are mahogany, cedar, oak, walnut, ash, rosewood, birch, beech, satinwood, pine, and a few others. The author argues that the

amateur requires no information at all—or practically none—about these woods, but recommends him to trust a respectable dealer. We venture to remark that both the dealer and the amateur stand in need of, and would have been much interested in, a good description of these various woods.

It would at least have been worth mention that the word mahogany, like most trade names of the kind, may refer to very different woods: thus the Cuban or Spanish mahogany (*Swietenia Mahogani*, L.) is a very different wood from the mahogany of India (*Cedrela Toona*, Roxb.), which goes more commonly, perhaps, under the name of cedar (Moulmein cedar), another fallacious appellation, since it has nothing in common with the cedar of the botanist (*Cedrus*), or the pencil cedar of commerce, which is a *Juniper*, while it is closely allied to the "Cuban cedar," also known as Honduras and as Mexican cedar (*Cedrela odorata*, L.). The author is partially alive to this, as his remarks on p. 42 show; but we think he might have put the whole matter in a much clearer light by giving good descriptions of these very different woods. The African mahogany, from Sierra Leone, is a different wood again.

Under *oak*, the author, as elsewhere, begs the whole question by the remark, "Oak, like mahogany, is too well known to require any minute description." Possibly so—it all depends on the meaning of the word "minute"; but we think that such a work as this would be very much more useful if a description of the general distinctive characters of oak were given, and that the reader is entitled to expect such a description. He mentions that several kinds of oak are in the market, but this kind of thing only confuses, instead of helps, the reader.

Then, again, what does the author mean by "rosewood"? The rosewoods of India—*Dalbergia latifolia* (Roxb.) and *Pterocarpus indicus* (Willd.)—are by no means the only timbers which come into this country under that name, and the author might have done much more than merely remark that, "so far as mere appearance is concerned, there is not much difference between the various kinds."

We think that the author has missed an opportunity of compiling what is very much needed in this country, a concise and practical chapter on the distinctive characters of the various cabinet woods, on the lines, for instance, sketched in Marshall Ward's little manual on "Timbers, and some of their Diseases." The expectation that something of the kind might have been attempted is the fairer, since the author, in this very chapter on "furniture woods," goes out of his way to reinstruct amateurs in the use of the multiplication table and superficial measurements, which "may have been forgotten since their school days."

The statement on p. 57 that wood does not contract in length requires modification; and some of the remarks on warping and shrinking would be more intelligible to a reader who understood something of the structure of his woods.

The illustrations are numerous, and, on the whole, good and decidedly useful; and in spite of the omissions we point out, we think the book admirably adapted in many respects for the amateur's shelves.

## OUR BOOK SHELF.

*L'Électricité dans la Nature.* Par Georges Dary. "Bibliothèque Internationale de l'Électricité et de ses Applications." (Paris: Georges Carré, 1892.)

A POPULAR and accurate account of the various forms and ways in which electricity appears in Nature is sure to find a great many readers, for the subject is most interesting. Everyone should become acquainted with at any rate some of the most ordinary electrical phenomena of every-day life, even if he should learn no more than the cause of a flash of lightning and the subsequent peal of thunder. In this volume the author has brought together accounts of many interesting phenomena that have been observed from time to time, with the hypotheses that have been put forward to explain them. The subject is divided into seven parts or chapters. The first relates to the origin, presence, and distribution of electricity in our atmosphere, and also to cosmical electricity, in which the influence of solar spots on atmospheric electricity and the electrical nature of comets and nebulae are mentioned. There are also descriptions of various conductors and electrometers, the principles of each being brought out clearly. Chapter ii. deals with storms. The author in this part has collected many typical examples which represent various classes of storms. After reference to the formation, height, and constitution of storm-clouds, and the variation and distribution of the storms themselves on the earth's surface, he describes the various forms in which lightning has been observed. Very curious effects, both on men and trees, are recorded to have taken place. An interesting instance here given relates to a flash of lightning that, having struck one tree and travelled down its trunk spiral fashion, suddenly leapt across to another one close by, and went to earth, the spiral curve being continued on this second tree. Chapter iii. contains some useful information relating to lightning-conductors, in which a brief historical summary is given: many kinds that have been or are now in use are described, with accounts of their action, verification, and efficiency. In the next two chapters, hail-storms, waterspouts, tornadoes, and cyclones are dealt with, while earthquakes and auroræ form the subjects of the concluding chapters.

In the above summary of the contents of this volume there is much to which we should have liked to refer, but the reader at any rate will be able to form a general idea of the range of subjects treated of in these four hundred pages.

Besides being interesting, the book will form a useful volume to many readers, for its value is very much increased by the great number of references inserted.

*The First Book of Euclid's Elements.* By the Rev. J. B. Lock, M.A. (London: Macmillan and Co., 1892.)

Now that the concession has been made by the University of Cambridge of allowing in all her public examinations any sound proof of the propositions of Euclid provided that their logical sequence remains unaltered, teachers of geometry will have a far freer scope; since they are no longer bound by any hard and fast rule. The present work, by a writer familiar to our readers, will be read with interest, for the arrangement of the text has undergone somewhat of a change from the sequence usually followed. With regard to the order of the propositions, it will be noticed that the theorems are separated from the problems. This seems to be advantageous, for after all there is a fundamental difference between theorems and problems: as the author says, a theorem is a geo-

metrical truth based on fundamental ideas and definitions of geometry, while problems entirely depend on postulates which are practically impossible.

The definitions have also received great attention, and are here thoroughly and clearly explained; in two cases, that of the "straight line" and "angle," the author has thought fit to make a slight divergence from the customary definitions. Accompanying the propositions are numerous exercises, while interpolated occasionally are many worked out examples.

Altogether, the book is one that should be in the hands of teachers, and is worthy of being well tested by them in their classes. W.

*The Ilford Manual of Photography.* By C. H. Bothamley. (London: The Britannia Works Co., Ltd., 1892.)

THIS manual, which has been compiled at the request of the Britannia Works Company, will be found by our photographic readers to be both well written and useful, containing as it does all information generally needed by amateurs. It is not a complete treatise on the subject, but is intended to aid those who are indulging in the various applications of this art at the present day from a thoroughly practical point of view. The first few chapters are devoted to the description of the apparatus, developing manipulations, faults in negatives, and various printing processes, all of which are well treated; we then come to the method of making enlargements, mounting and framing, lantern slides and transparencies. The concluding chapters are of special interest, consisting of portraiture, copying, photographing of objects in motion, orthochromatic photography, and photography by artificial light.

Preceding the appendix are tables of English and French weights and measures, while the appendix itself contains some formulæ and reprints from one or two photographic journals. Besides an account of the Ilford universal hydroquinone developer, there are papers by Mr. John Howson, on the "Printing Paper of the Future," "Lantern Plates," together with the best methods of cutting up printing-out paper.

A most useful table presents a list of dealers and dark rooms situated all over the world, ranging from modest dealers in Bettws-y-Coed and Leighton-Buzzard to those in South Africa, New Zealand, and Japan. From this table, it can be at once ascertained whether, at a certain place, Ilford plates or paper, chemicals or apparatus, are kept in stock; whether amateurs can receive help or get work done for them, such as printing, mounting, &c.; or whether a dark room is obtainable or not. This list, when thoroughly completed, and other first-class firms included, will be invaluable for tourists on the Continent, while at present it should be used very largely by those travelling in this country. W.

*The Advanced Class-Book of Modern Geography.* By William Hughes and J. Francon Williams. (London: George Philip and Son, 1892.)

IT is impossible not to have some pity for the unfortunate boys and girls who will have to learn geography from this gigantic "class-book." It consists of more than 800 closely-printed pages, the very appearance of which would suffice to discourage most young students. Geography is one of those subjects in the learning of which very much more depends on the teacher than on the text-book; and a good teacher would have no desire to see so elaborate a work as this in the hands even of "advanced" pupils. The information, so far as we have been able to examine it, is accurate; but it is not, as a rule, presented in a way that would be likely to excite interest or curiosity.

## LETTERS TO THE EDITOR.

[The Editor does not hold himself responsible for opinions expressed by his correspondents. Neither can he undertake to return, or to correspond with the writers of, rejected manuscripts intended for this or any other part of NATURE. No notice is taken of anonymous communications.]

## Carpenter on Eozoon.

THE scientific world is deeply indebted to Dr. Dallinger for his excellent new edition of Carpenter's invaluable work on the microscope, and among other things for his retaining unchanged the description of *Eozoon canadense*, as a monument of an important research up to a certain date.

Dr. Carpenter devoted much time to the study of Eozoon, and brought to bear on it his great experience of foraminiferous forms, and his wonderful powers of manipulating and unravelling difficult structures. After having spent years in studying microscopic slices of Eozoon and the limestones in which it occurs, I have ever felt new astonishment when I saw the manner in which, by various processes of slicing and etching, and by dexterous management of light, he could bring out the structure of specimens often very imperfect. Not long before Dr. Carpenter's death I had an opportunity to appreciate this in spending a few days with him in studying his more recently acquired specimens, some of them from my own collections, and discussing the new points which they exhibited, and which unhappily he did not live to publish. Some of these new facts, in so far as they related to specimens in our cabinet here, have since that time been noticed in my *résumé* of the question in the *Memoirs of the Peter Redpath Museum*, 1888; but I hope my friend Prof. Rupert Jones may yet be able to complete Dr. Carpenter's work.

Those who know Dr. Carpenter's powers of investigation will not be surprised that later observers, without his previous preparation and rare insight, and often with only few and imperfect specimens, should have failed to appreciate his results. One is rather surprised that some of them have ventured to state with so great confidence their own negative conclusions in a matter of so great difficulty, and requiring so much knowledge of organic structures in various states of mineralization. For myself, after working for fifty years at the microscopic examination of fossils and organic rocks, I feel more strongly than ever the uncertainties and liabilities to error which beset such inquiries.

As an illustration in the case of Eozoon: since the publication of my memoir of 1888, which I had intended to be final and exhaustive as to the main points, and in so far as I am concerned, I have had occasion to have prepared and to examine about 200 slices of Eozoon from new material: and while most of these have either failed to show the minute structures or have presented nothing new, a few have exhibited certain parts altogether unexpected perfection, and have shown a prevalence of injection of the canal system by dolomite not previously suspected. Since that publication also, the discoveries of Mr. Matthew in the Laurentian of New Brunswick, and the further study of the singular Cambrian forms of the type of *Cryptozoon*, have opened up new fields of inquiry.

I think it proper to state, in reference to Dr. Dallinger's footnote on the recent paper of Mr. Gregory, that it must not be inferred from it that Mr. Gregory had access to my specimens from Madoc and Tudor, though he no doubt had excellent material from the collections of the Canadian Geological Survey. It might also be inferred from this note that I have regarded the Madoc and Tudor specimens as "Lower Laurentian." The fact is that I was originally induced in 1865, by the belief of Sir W. E. Logan at that time that these rocks were representatives in a less altered state of the middle part of the Laurentian, to spend some time at Madoc and its vicinity in searching for fossils, but discovered only worm-burrows, spicules, and fragments of Eozoon, which were noticed in the *Journals of the Geological Society for 1866*. (The more complete specimen from Tudor was found by Vennor in 1866.) On that occasion I satisfied myself fully that the beds are much older than the Cambro-Silurian strata resting on them unconformably; but I felt disposed to regard them as more probably of the age of some parts of the Huronian of Georgian Bay, which I had explored with a similar purpose under Logan's guidance in 1856. As my work was not official, and was palæontological rather than stratigraphical, it did not seem proper to express any dissent from what were at the time the probable conclusions of strati-

graphical work; but I was quite prepared to assent to the new views afterwards adopted.

In conclusion, the new material bearing on Eozoon is accumulating so rapidly that I cannot hope to be able to master it in detail, but shall be glad to aid others who may have more time; but I hope to be able, in a work now in preparation, at least to present the facts up to date in a popular form.

J. WILLIAM DAWSON.

McGill College, Montreal, February 3.

## The Samoan Hurricane.

REPLYING to the communication in NATURE of December 17, 1891 (p. 161), signed "H. F. B.," relative to my preliminary report on the Samoan hurricane of March 1889 (published in the *Proceedings, U.S. Naval Institute*, vol. xvii., No. 2, and in the *American Meteorological Journal*, July 1891), I would submit the following statement.

First of all, I wish to acknowledge Mr. Blanford's appreciation of the difficulties involved in the consideration of the subject, owing to the meagreness of the data; and at the same time to express my own appreciation of the fact that he himself has not had access even to such data as we have succeeded in collecting, but only to my necessarily brief discussion thereof, and the conclusions that I have drawn therefrom.

Mr. Blanford's explanation, as I understand it, is as follows: the vortex of the hurricane formed north or north-east (on the equatorial side) of Apia on the afternoon of the 15th, within a "region of disturbance" that had already caused stormy weather throughout the Samoan Islands and a decided barometric depression at Apia. The first effect of this formation was (by adding slightly to the normal evening rise of the barometer) to cause a decided rise of pressure, which, however, decreased again as the vortex slowly approached the harbour, thus causing the second minimum (the afternoon of the 16th), the duration of the storm being explained by the usual slow motion of the newly formed hurricane.

To the above explanation it is necessary to make a correction, I think, owing to the fact that the shifts of wind at the time of and immediately after the first minimum show that the centre of the disturbance then passed to the westward of Apia, and as the wind thereafter remained from north to north-east, the centre (or vortex) evidently remained to the southward and westward. This fact, however, merely introduces a change in the position where the new vortex formed, according to the theory under discussion.

Revising Mr. Blanford's explanation, then, in the light of this correction, it appears that the track of the depression is about as I have drawn it, but that a vortex formed slightly to the southward and westward of Apia, thus causing a slight rise of pressure at first, succeeded by a second fall, and the slow motion of this newly formed vortex caused the duration of the northerly gale.

Now, I must here take exception to one of Mr. Blanford's statements, which is as follows (referring to the theories given in my paper): "None of these explanations seem to take account of the circumstances that attend the formation of tropical cyclones, which, as we have elsewhere pointed out, differ in many respects from the storms of the temperate zone." A reference to my paper will show, I think, that I took into consideration the special peculiarity to which Mr. Blanford calls attention, and went so far as to insert a plate in order to illustrate two types of storms—namely, (1) the characteristic tropical hurricane type (where there is a decided vortex, or "centre of aspiration"); and (2) the type where there is a comparatively wide central region surrounded by an annular space where there are steep barometric gradients and correspondingly high wind velocities, but without any decided vortex, properly so called. I said also that "it will be seen that the indications are that the Samoan hurricane (on the 15th and 16th, at least) was of the second type, although during the 17th and 18th it doubtless became more like the first." In a word, I said (both explicitly and by means of the varying strength of the track drawn on the chart) that the depression passed Apia on the afternoon of the 15th, recurved (increasing in intensity and delaying whilst recurving, each of which is to be expected), and then moved off to the southward and eastward. I do not intend to convey the impression that I made any definite statement as to just when or where the vortex formed, nor am I wholly prepared to hazard such a statement even at

this late date. I can still only repeat here what I said before, as follows:—

"My idea is, briefly, that the first depression occurred as the storm passed on its westward track, followed by the usual shift of wind to the northward. Along this branch of its trajectory its severity was probably not quite so great as it was later, and the force of its southerly winds was masked by the mountains on the island of Upolu; possibly careful observations of the rapidity of motion and the character of the clouds, or of the state of the sea off the harbour, might have indicated a severe storm, but this does not appear from the evidence at hand, though well worth considering. During its recurve the hurricane probably increased in intensity, the barometric depression at the centre deepening, and thus causing the second depression observed at Apia, which was slightly deeper than the first, although the centre itself was really at a greater distance than on the previous day."

"Unfortunately, as stated above, we have no very definite data regarding the severity of the storm before it reached Apia, although I must say that a barometric depression of 0.76 inch below the normal in the tropics is very suggestive of the presence of a fully developed vortex, and it seems more than likely that if the harbour had not been well sheltered to the southward the southerly gales would have been quite as severe as those from the north. The only early data that we have, other than the reports from Apia, are contained in the following very brief report from the American schooner *Equator*, Captain Reid:—

"March 14 (Samoa date), lat. 12° 00' S., long. 170° 50' W., wind S., S.W., W., N.W.; thick, squally; howe to.

"March 15 (Samoa date), lat. 13° 00' S., long. 170° 40' W., wind N.W.; fierce gale; squalls; heavy sea."

This, although brief, seems to indicate that it was a fully developed hurricane that was approaching Apia, and I am inclined to the opinion that such was actually the case.

Mr. Blanford will surely admit that it is one recognized peculiarity of tropical hurricanes to reduce their speed of translation whilst they are recurring, and he will thus admit also that such recurvature accounts, in the present case, for the duration of the northerly gale at Apia. So far as the sharpness of recurvature is considered, I would say that the report of the *Equator* is sufficiently vague to allow us to draw a curve with a somewhat less sharp recurvature, and I should myself have done so but for the single fact that a hurricane approaching from a more northerly direction must have sent a northerly or north-easterly swell into the harbour that would have been felt to at least such an extent as to be noted in the log of one or more of the vessels there, but I have looked in vain for any such remark, until after the shift of wind on the afternoon of the 15th.

In conclusion, I take pleasure in expressing my obligation to Mr. Blanford for his interesting and able discussion of the subject, which, even with all the data at hand, has still many perplexing features. The principal object of this preliminary publication was to elicit comment and discussion, and it will be very gratifying if other authorities will give us the benefit of their experience and suggestions.

EVERETT HAYDEN.

Hydrographic Office, Washington, D.C.,

January 4.

THE distinction to which allusion was made in the passage quoted by Mr. Hayden is not, as he seems to have understood, that between tropical and extra-tropical storms when fully formed, but between the circumstances of their respective formation. These are that, in the former, the cyclonic circulation of the winds is preceded by much irregular action, which sometimes extends over a considerable area. Within this area there are local squalls and shifts of wind, with heavy rainfall, but the action is not for some time definitely concentrated and cyclonic. This preliminary stage does not appear to obtain in the storms of the temperate zone, where the deviating effect of the earth's rotation is so much greater than in low latitudes, and indeed, if we accept the views of Werner Siemens and Prof. Hann, the cyclonic circulation is the cause and forerunner of the storm. I cannot think it probable that a vortex, once fully formed, and travelling towards higher latitudes, should recurve so sharply as to produce a fall of the barometer on two successive days (with a rise in the interval) at the same place, simply by twice passing in its vicinity. To effect this, the

recurvature must, as I apprehend, describe an angle considerably less than a right angle, and of such I know of no example among tropical cyclones. At the same time, my own view was put forward merely as a suggestion, and in no dogmatic spirit.

H. F. B.

### Phoronomy.

ABOUT thirty-five years ago, I had a conversation with the late Dr. Donaldson, a well-known Greek scholar of the time, in which we discussed the appropriateness of the use of the word kinematics, in the sense in which it was then, and is now, employed by writers on mathematical science. Dr. Donaldson's opinion was that it is not the best word which can be employed to represent the science of pure motion, without regard to causation. He said that the word *κινεω* involved the idea of the cause of motion, and therefore that it ought not to be used when the idea of causation is to be completely set aside. He further gave it as his opinion that the word *φωρεω* is more nearly expressive of the idea of mere going, without any reference to the cause of motion, and therefore that the proper word would be phoronomy, or phorotics.

I was so much impressed by this conversation that, for many years, I headed with the word phoronomy the papers of questions on the subject of pure motion which I was in the habit of preparing for College lectures and private pupils.

I have recently consulted a very eminent Greek scholar, and his opinion is that, on the whole, the word phoronomy is more distinctly expressive of the science of pure motion than the word kinematics. He agreed with Dr. Donaldson that the word kinematics suggests some idea of causation, whereas no such idea is suggested by the word phoronomy.

As a matter of history, the word *cinématique* was introduced by Ampère to represent the purely geometrical science of motion in the abstract, and was anglicized into kinematics by, I think, the late Dr. Whewell.

Sir W. Thomson and Prof. Tait, in the preface to their "Natural Philosophy," adopt the suggestion of Ampère, and employ the word in the same sense. They also employ the word *dynamics* in its true sense as the science which treats of the action of force, whether it maintains relative rest, or produces acceleration of relative motion. They further state that these two corresponding divisions of dynamics are conveniently entitled *statics* and *kinetics*.

Here, then, we have two words, kinematics and kinetics, both derived from the same root-word, employed to represent two entirely different sets of ideas; and there is not the same broad line of demarcation between the words themselves as there is between the sets of ideas which they are intended to connote.

Hence it appears to me that the word phoronomy, the law of going, is the most suitable, as it is the most expressive word, to represent the science of pure motion in the abstract.

At the time of my conversation with Dr. Donaldson, we were neither of us aware that the word had been already invented and employed. Some years after, I found that a treatise was published at Amsterdam in 1716, entitled "Phoronomia, sive de viribus et motibus corporum. Autore Jacobo Hermanno, Basil." Hermann, however, uses the word in much the same sense as we now use the word dynamics.

The point has been recalled to my mind by the discovery that the word has been employed in Germany in the sense in which Dr. Donaldson advocated that it should be used.

In the treatise entitled "Allgemeine Mechanik der Punkte und Starren Systeme," by E. Budde, published in 1890 at Berlin, the word phoronomy is adopted, and the author gives his reasons in the following words:—

"Man kann eine Ortsveränderung zunächst rein geometrisch, ohne alle Rücksicht auf ihre Ursachen, betrachten, und das soll in den nächsten Capiteln geschehen. Die Disciplin, welche sich mit dieser Betrachtung befasst, heisst *Phoronomia* oder *Kinematik*. Der Name Kinematik ist seit Resal der gebräuchlicher gewesen; neuerdings aber wird von Reulaux und seinen Schülern die Morphologie der Verknüpfung von Maschinenteilen als 'Kinematik' bezeichnet. Wir wählen deshalb hier den Namen Phoronomia."

With reference to this statement of Budde's, I observe that Ampère, in the "Essai sur la Philosophie des Sciences," particularly mentions trains of machinery, such, for instance as the works of a watch, as coming under the heading kinematics.

I also find that Grassmann, in the "Ausdehnungslehre von



1844," published at Leipzig in 1878, speaks of "Phorometric" as representing "die reine Bewegungslehre"; and I see that Möbius uses the adjective in an article on the "Phoronomische Deutung des Taylor'schen Theorems."

A change in scientific nomenclature is by no means an unprecedented occurrence.

For instance, notwithstanding the great authority of Lagrange, the phrase "virtual velocity" has been practically superseded by the phrase "virtual work," and in the year 1876 the word "work" was substituted for "virtual velocities" in the regulations, published in the Cambridge University Calendar, for the Mathematical Tripos.

Another instance is the fact that the phrase *vis viva* has been superseded by *kinetic energy*, as a more convenient term in the expression of the principle of energy.

Further, I notice that Prof. Tait, in lectures on "Recent Advances in Physical Science," gives the suggestion that the time-honoured word force is in all probability destined, as science advances, to be relegated to the limbo of departed nomenclature.

For these various reasons, then, I trust that I shall not be regarded as an iconoclast, if I venture to substitute, for the word *kinematics*, the word *phoronomy*.

W. H. BESANT.

St. John's College, Cambridge, February.

### On the Terms "Centrifugal Force" and "Force of Inertia."

THE retention, in the last edition of Mr. Loney's "Elements of Dynamics," 1891, of a paragraph (p. 141) which resuscitates the objections formerly urged by some writers against the use of the term "centrifugal force" seems to call for a protest. It is to be regretted that students of dynamics should find absolutely contradictory statements presented to them respecting the validity of this term. While, however, in one set of text-books we find a perfectly clear definition and consistent use of the phrase "centrifugal force," there does not, on the other hand, appear to be unanimity of ideas amongst the objectors, nor always sufficient clearness in expressing the same.

In the uniform circular motion of a ball rolling on a table against the inner surface of a vertical cylinder, the pressure of the cylinder upon the ball is a centripetal force directed towards the centre of the circle. The contrary pressure of the ball upon the cylinder is the "centrifugal force," which is defined as the reaction to the centripetal in this case, and in every case as the reaction to the normal component of the centrifugal force.

The foregoing definition or usage of the term is adopted without hesitation or apology in the following works, named in order of date:—

Poisson's "Traité de Mécanique," 1833, vol. i. p. 332, or Harte's translation, 1842, p. 256.

Walton's "Mechanical Problems," 1842, pp. 240, 260, 269.

Prof. Niven in "Cambridge Senate-house Problems," 1877, p. 78.

Thomson and Tait's "Natural Philosophy," 1879, p. 221.

Garnett's "Elementary Dynamics," 1875, p. 205, and 1882, p. 255.

Routh's "Rigid Dynamics," Part I., 1882, p. 217, and Part II., 1884, p. 15.

Williamson and Tarleton's "Dynamics," 1889, p. 88.

Objections to the term appear in—

Goodwin's "Course of Mathematics," 1849, p. 275.

Parkinson's "Mechanics," 1863, p. 249.

Blakie's "Dynamics," 1887, p. 32.

Rankine, "Encyclopædia Britannica," "Mechanics," 9th edition.

Loney's "Statics and Dynamics," 1891, p. 141.

Other authors might have been cited, but I have referred to such as I happen to possess.

Nearly all these objectors evince the same reluctance to giving the name of "force" to the reactionary effect of the body's inertia in the direction of the normal outwards. Yet, if we admit that "to every force there is an equal and opposite reaction," it is not easy to escape from the conclusion that such a reactionary force exists.

Mr. Loney, however, postulates both forces, but adds:—"Centrifugal force is a very misleading term. It seems to imply that the force belongs to the mass instead of being an external force acting on the mass. A somewhat less misleading

term is centripetal force. We shall avoid the use of either expression; the student who meets with them will understand that either (*sic*) means the force which must act on a mass to give it the acceleration normal to the curve in which it moves."

These are confusing directions to the student, who must be left in complete bewilderment as to any distinction in meaning between "centripetal" and "centrifugal." "Centrifugal," from its derivation, signifies that the force has a tendency to make the body fly away radially from the centre. And such a tendency there is, and such a motion would result if we could make the centrifugal force last (ter the centripetal has ceased). But in the objections taken the word "tendency" is regarded as though it implied an actual subsequent motion in the direction of the tendency. A beginner is almost certain to fall into the error of imagining that, when the cord is slipped, the stone from a sling will dart away in a direction intermediate between that of the string and its own previous motion in the circle. But the name "centrifugal" is not answerable for this. The idea is due to the unmistakable pull upon his hand of an outward tending force, to which "centrifugal" merely gives the right name. Clearer conceptions show him that the two forces, the action and the reaction, cease at the same instant when the string is cut, and that there is no initial velocity in either direction.

Uniform circular motion is perfectly unique. In the direction of the force there is no motion, in the direction of the motion there is no force. The real *crux* lies in this conception of a constant acceleration with a perpetual zero velocity in the direction of the acceleration. How, says one, can there be a rate of change when the change itself is zero? But the objection is a metaphysical one, and it may be urged with equal force against the whole doctrine of limiting ratios.

Mr. Loney's statement that the centrifugal reaction is not a force belonging to the mass, but "an external force acting on the mass," requires some elucidation. Dr. Parkinson, in the paragraph referred to, has something similar. He says that the term "centrifugal force" "vaguely conveys an impression, as it were, that the particle of itself resisted curvilinear motion and exerted a force *per se* to move in a rectilinear path, which innate tendency was only overcome by the action of some external force." He also grudgingly recommends the student to use the obnoxious phrase "simply as an equivalent for the moving force in the direction of the normal." Here again "centrifugal" is made to signify a tendency towards the centre! Is not the vagueness complained of imported into the subject in some measure by the writers themselves?

Whatever names are employed, the facts are these. The force towards the centre communicates to the body an acceleration in that direction, which acceleration gives rise (we know not how, but we say by the law of inertia) to a force equal and opposite to the force which produced the acceleration. This reaction always appears to emanate from the mass of the moving body, and it has therefore been called "the force of inertia" of the body. Although this view has been combated by Poisson and others, some of the latest authorities are reasserting it. Thus in Thomson and Tait, 1867 and 1879, we find in Article 216: "Matter has an innate power of resisting external influences."

... This the inertia of matter, &c." Again, in Sir Robert Ball's "Experimental Mechanics," 1888, p. 252: "When any agent acts to set a body in motion or to modify its motion in any way, the body reacts on the agent, and this force has been called the kinetic reaction."

I cannot see any objection to designating this reaction "the force of inertia." It is a provisional term, which will serve our purpose until the nature of force is better understood. Poisson's argument against it, derived from our experience of friction, appears to me invalid, and his illustration irrelevant, because the law of resistance is not the same as in the case of inertia. If it had happened that the law governing friction was that the resistance to motion was directly proportional to the acceleration, then if a body were moving with constant velocity upon a rough plane there would be no resistance from friction. The smallest acceleration of velocity would give rise to a correspondingly small amount of friction, a double acceleration would double the resistance from friction, and so on, precisely as with the resistance from inertia. GEORGE S. CARR.

### A Lecture Experiment in Surface Tension.

HOPING it may be of interest to some of your readers, I venture to send you the following description of a simple ex-

periment on surface tension. A drop of water hanging from the end of a vertical glass tube is regulated in size until it is just on the point of falling away from the tube. On dipping the end of a penholder in ether, and bringing the wet end within a few millimetres from the drop, the latter promptly falls. The drops may be produced and adjusted in the following manner:—

A piece of glass tube, about 8 cms. long and 8 cms. in diameter, is made into a pipette with an orifice about  $\frac{1}{15}$  cms. diameter, and fitted with a small india-rubber ball at the other end. The tube is then passed through a hole in a piece of wood large enough to rest on the top of a common tripod stand, as shown in the figure. A strip of wood, or a paper-

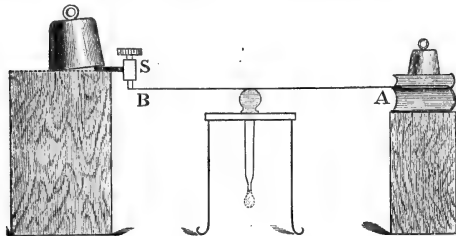

knife, about 30 cms. long, is placed with its centre resting on the top of the ball, one end (A) being held between the two uppermost of a pile of books, and the other end (B) passing under a screw (s). The ball is squeezed, a beaker of water brought under the end of the pipette, and the tube allowed to fill by the expansion of the rubber. By working the screw s, a drop is formed at the end of the tube, and since one complete turn of the screw I use only lowers the end of the rod (B)  $\frac{1}{8}$  inch, it is possible to adjust the drop with great nicety. As the ether is brought up, the absorption of its vapour diminishes the surface tension over a small area of the drop of water, and currents, made visible by suspended dust, appear to pass from the interior towards the weakened spot. Bringing the ether still nearer, the drop often becomes much agitated, and finally, when the distance is reduced to about 4 mm., it falls away from the tube.

E. D. FRIDLANDER.

Mason College, Birmingham, February 29.

#### The Orientation of Ancient Monuments.

THE deeply interesting results obtained by Mr. Norman Lockyer with regard to the orientation of Egyptian temples, and by Mr. F. C. Penrose with regard to the Greek, tempt me to call attention to an extract from the *Century Magazine*, May 1883, from an article by Frank Cushing, describing a visit to the Zuñis, a typical tribe of the Pueblo Indians of New Mexico, in 1879:—

"Each morning just at dawn, the Sun priest, followed by the master priest of the Bow, went along the eastern trail to the ruined city of Ma-tsa-ki by the river side, where, awaited at a distance by his companion, he slowly approached a square open tower, and seated himself just inside upon a rude ancient stone tower, and before a pillar sculptured with the face of the sun—the sacred hand—the morning star and the new moon. There he awaited, with prayer and sacred song, the rising of the sun. Not many such pilgrimages are made ere the 'suns look at each other,' and the shadows of the solar monolith, the monument of Thunder Mountain, and the pillar of the Gardens of Zuñi lie along the same trail; then the priest blesses, thanks, and exhorts his father, while the warrior guardian responds as he cuts the last notch in his pine-wood calendar, and both hasten back to call from the house-top the glad tidings of the return of spring. Nor may the Sun priest err in his watch of Time's flight; for many are the houses in Zuñi with scores on their walls or ancient plates embedded therein, while opposite a convenient window or small port-hole lets in the light of the rising sun, which shines but two mornings of the 365 on the same place. Wonderfully reliable and ingenious are these rude systems of orientation, by which the religion, the labours, and even the pastimes of the Zuñis are regulated."

In like manner, we read in Prescott that at Quito the festival of the Sun-god was held when "he sat upon the pillar," i.e. a pillar cast no shadow.

NO. 1168, VOL. 45]

Might not this Zuñi ceremonial be a description of one enacted at some primitive astronomical temple such as Stonehenge? and do we not gain the best insight into the minds of those who in the Archaic period first orientated—the Babylonian and Assyrian ziggurats, the pyramids and temples of Egypt, the temples of Greece, and our own Stonehenge—by seeing how a people in a similar stage of intellectual and scientific development are acting to-day? FRED. F. GRENSTED.

Merchant Taylors' School, Crosby.

#### The Nickel Heat Engine.

MR. KARAMATE, in a letter which appears in your issue of March 3 (p. 416), alludes to a new form of heat engine described by me in your issue of January 28 (p. 294). He states that my device is similar to one by Prof. Stefan. I wish to point out that the two heat engines are quite different in design. The engine of Prof. Stefan has a step by step action; that described by me is under certain conditions absolutely continuous in its action. The contrast is shown by Mr. Karamate's description of Prof. Stefan's engine; he writes:—"Nickel plates were fixed on a wheel, like that of a water-mill, and a magnet was placed before it. By heating a nickel plate before the magnet, it was repulsed by the magnet, and a succeeding plate was attracted, so that the wheel commenced to rotate." From this it seems clear that the action of the machine must be step by step, since the different pieces of nickel must come successively under the influence of the magnet and the flame. In my disk form of engine, the action, when the disk has a certain thickness, is continuous. Mr. Croft has recently shown that when the disk is not so thick as mine was the disk starts in one direction, then stops, and sets off in the opposite direction. It will also be noticed that the distribution of the magnetic field due to two poles is entirely different from that in the machine of Prof. Stefan. Mr. Karamate writes: "By heating a nickel plate before the magnet, it was repulsed by the magnet." I hardly see how this repulsion takes place. Faraday, writing about the behaviour of nickel, states ("Experimental Researches," vol. iii., 2346): "Upon being heated the nickel soon became indifferent to ordinary magnets, but, however high the temperature, still it pointed to and was attracted by the electro-magnet." Surely the action of the engine is due to one piece of nickel becoming partly non-magnetic owing to a rise of temperature, thus upsetting equilibrium, and allowing the next piece of nickel to approach the magnet and consequently the flame.

I may add that E. Berliner in 1885, and Edison in 1887, patented magnetic heat machines on the step by step principle.

FREDERICK J. SMITH.

Trinity College, Oxford, March 4.

#### The Limpet's Power of Adhesion.

I WOULD like to call the attention of your readers to the results of some experiments, which, I think, are original, referring to the power of adhesion of the common limpet (*Patella vulgata*).

The experiments were carried out as follows, with the assistance of my friend J. Snel, of the Biological Laboratory here. The shell of the limpet *in situ* was perforated, so as to allow of the attachment of a delicate spring balance, by means of which a gradually increasing strain could be put upon the animal, in a direction normal to the foot. The pull was increased until the animal became detached, and the final weight and the greatest and least diameters of both foot and shell noted.

The following figures are compiled from a series of twenty consecutive experiments, and are typical of other similar series. The individuals operated on were not chosen in any way.

##### Averages of Twenty Consecutive Experiments.

Area of shell, in square inches ... ..	1.07
Pressure per square inch of shell ... ..	22.5 pounds.
Area of foot, in square inches ... ..	.45
Pressure per square inch of foot ... ..	54.3 pounds.
Gross weight ... ..	23.9 "
Maximum pressure per square inch of shell area	31.3 "
Minimum " " " "	13.9 "
Maximum " " " " foot area	71.1 "
Minimum " " " "	37.1 "
Maximum gross weight ... ..	32 "
Minimum " " " " " "	12 "

The areas in the above table are calculated on the assumption that both shell and foot are ellipses, which is fairly near the truth. I need hardly point out that the old theory of atmospheric pressure will not account for these figures, and in the case of *Patella* the mucus is too thin to have much cohesion. Perhaps some of your readers can throw light on the subject.

29 St. James's Street, Jersey.

PERCY A. AUBIN.

#### On the Variation of Latitude.

In connection with the interesting investigations of Dr. Chandler on the variation of latitude, permit me to suggest the desirability of calling attention to Maxwell's remarks on the same subject at the conclusion of his paper "On a Dynamical Top," Ed. Phil. Trans., xxi., Part iv. p. 568 (read April 1857).

Maxwell, taking the value of  $\frac{C}{A}$  as 1'00309, as deduced from the

amount of precession (Pontécoulant, ii. 268), finds the time of revolution of the pole of the earth about the true pole to be about 325'6 solar days. Dr. Chandler's period of 427 days would on the same principles correspond to the value  $\frac{C}{A} = 1'00235$ .

ROBT. B. HAYWARD.

Fairlight, Harrow, February 28.

#### ORNITHOLOGY OF THE SANDWICH ISLES.

THE departure for Honolulu of Mr. Robert C. L. Perkins (as already announced in these pages), the gentleman sent out by the Joint Committee appointed by the Royal Society and by the British Association to investigate the zoology of the Sandwich Islands, may render the present moment opportune for noticing what has already been done towards obtaining a knowledge of their presumably expiring Fauna, though I can only lay claim to acquaintance with a single Class of it—the Birds. Yet students of that important branch of Biology which is known by the clumsy and not strictly accurate title of the "Geographical Distribution of Animals," will bear in mind that the first successful attempt to grapple with and elucidate it was based upon this very Class; and, furthermore, that by far the most comprehensive work on the subject has proceeded from the pen of a most proficient ornithologist, while nobody can doubt that but for his intimate knowledge of Ornithology many of his results would have been inconclusive if not unattainable. Into the reason why the most vagrant Class in creation was thus so serviceable to Mr. Sclater and to Mr. Wallace, there is no need here to enter. It is perhaps enough to state that indubitable fact to warrant the publication of the present remarks having reference to a small portion only of the Hawaiian Fauna; and, if they should furnish an indication of what may be proved when the rest comes to be better known, it will so much the more redound to the credit of Ornithology; while, should further acquaintance with other Classes contradict the inferences to be drawn from the Birds, the suspicion, to call it by no stronger name, at times expressed, that what is a good Law of Nature for one set of animals will not hold for another, may be justified.

Moreover, within the last six months has been published a very remarkable dissertation, "On the Structure of certain Hawaiian Birds, with reference to their Systematic Position," contributed by Dr. Gadow to Mr. Scott B. Wilson's beautifully illustrated "Birds of the Sandwich Islands." From its title, this essay might be supposed to interest only the taxonomer or the ornithotomist; and the zoologist of wider views might leave it unheeded as having a scope too limited for his purposes. The very contrary is the truth, and those who will follow the author's deductions to their logical end will perceive that his "Remarks" disclose a state of things which is not only subversive of the generally-received opinion as to the nature and affinities of the avifauna of the Sandwich

Islands, but is fraught with evidence of a kind hardly hitherto suspected in regard to the origin and derivation of the animal population of that group. Hints to this effect may, indeed, be gathered from Mr. Wallace's works, and especially from his "Island Life"; and that, with the few facts at his disposal, he was able to give them, is proof of the depth of his perception; but henceforth he will be able to speak boldly, and drop every uncertain phrase.

The dearth of facts with which Mr. Wallace had to contend, even in 1880, shows that the Sandwich Isles have not been fortunate in their Natural Historians, though perhaps no worse off in this respect than many another group "lying in dark purple spheres of sea." Discovered in 1778 by Cook, during the last of his celebrated voyages, his ships communicated with one of the more western islands—Atooi, as its name sounded to him and his companions, but since, and doubtless more correctly, written, Kauli. The admiration of the visitors was excited by the cloaks and helmets of the natives, beautifully bedecked with feathers, the more or less moth-eaten remains of which may yet be seen in many a Museum; and the scarlet birds which furnished the most brilliant adornment of these ingenious works of art were duly mentioned by Cook in his journal as published. After less than a fortnight's stay, in the course of which the existence of five islands was made out, his ships stood off to the northward to prosecute their voyage of discovery. Towards the end of the year they returned, and Cook, having had experience of the hospitable treatment of the islanders, designed to make his winter-quarters in the Sandwich Isles, as he had named them, after the then First Lord of the Admiralty; but, keeping more to windward, the first land he made was the most eastern of the group, one that he had not even seen on his first visit. This was the historic Owhyhee—nowadays written Hawaii—which, being the largest of them, and that which produced the warrior-king and statesman who eventually subdued all the rest, has given its official name to the Archipelago.

Though Owhyhee was sighted on November 29, Cook's course along its eastern and southern coast was so deliberate that it was not until January 17, 1779, that he found a safe anchorage, and that in Kealeakua Bay, on its western side. What passed there during the next three weeks need not be here recorded, but those who know how to read his narrative and the accounts since divulged from native sources will admit that it throws an important and yet most lurid light on the history of superstition. To the unprejudiced it must be doubtful whether even now the whole truth is or ever can be known. The ships sailed on February 4; but in making her way to the northward, the *Resolution* sprung her mainmast, and within a week returned to her old anchorage. Three days later occurred the terrible tragedy which deprived the world of one of its greatest seamen. A week after Cook's death, the ships sailed to the westward, touching at some of the intermediate islands—Mowee (Maui), Lanai, and Morotai (Molokai), making once more for Atooi (Kauai) and Oneehow (Niihau), the last famous for its yams. Then, on March 15, they bore away again to the northward, and did not return.

Now, the object of giving here these details is to show that the natural history specimens obtained by Cook's ships were procured only on the islands of Hawaii, Kauai, and Niihau. This is the more needful because the first descriptions of any of the birds of the Sandwich Isles were given, with two exceptions, by Latham in his "General Synopsis of Birds," published in 1781-85, and most of the specimens so described no longer exist. Some were in the British Museum or the collection of Sir Joseph Banks, afterwards transferred thereto; the rest were in the Leverian Museum. Of the former, as is

well known, not one remains; but fortunately, at the breaking up of the last in 1806, a few were bought by the then Lord Stanley, who (dying in 1851, as thirteenth Earl of Derby, and President of the Zoological Society) bequeathed his collection to the borough of Liverpool, and there, thanks to the care that has been taken of them, they still exist in fair condition. A few more were bought for the private collection of the then Emperor of Austria, and are still carefully preserved in the Museum of Vienna. Of several of the species it is not known that any other specimens were brought to Europe until some three years ago. On both of Cook's previous voyages qualified naturalists had been sent; but, as is known, the arrangements for publishing their discoveries were so imperfect that little credit followed to anyone concerned. On this, his third and last voyage, there was no expert, though Mr. William Ellis, who in an irregularly published narrative, calls himself "Assistant Surgeon to both vessels," was somewhat of a draftsman, and made a series of sketches, which, becoming the property of Banks, subsequently passed to the British Museum. The commoner species of Sandwich-Island birds are generally recognizable, but others are so unhappily limned that even the word caricature (which always implies some likeness) seems too strong to apply to them. Nevertheless, Mr. G. R. Gray adventured to determine all of them.

More than a quarter of a century passed before any further progress was made in the knowledge of the zoology of the Sandwich Isles, though they were visited by numerous ships, and in 1794 were ceded to Britain under Vancouver. In 1814 an attempt was made to seize them for Russia; and Kotzebue, whose voyage has so much scientific interest, was there in 1816-17, but the accomplished naturalists, Chamisso and Eschscholtz, who were with him, took little heed of the fauna of the islands.<sup>1</sup> The year 1822 saw the arrival of the more celebrated William Ellis, whose missionary labours throughout the Pacific and in Madagascar are so widely known. The Sandwich Isles had by that time fallen under the sway of the conquering Kamehameha I, whose son and successor, desirous of seeing European civilization, arrived in England in 1824 with his wife—both to die of measles within a few weeks. The British Government determined to send their remains for interment in Honolulu, by that time become the capital of the islands, and accordingly H.M.S. *Blonde*, commanded by George Anson seventh Lord Byron (first cousin and successor to the poet), was commissioned to convey the dismal freight. The duty was performed, and the islands again were ceded to the British Crown, but again declined. On board the *Blonde* sailed as chaplain Mr. Rowland Bloxam, together with his brother Andrew, who was somewhat of a naturalist, and it was intended that the published account of her voyage should contain a proper appendix on the natural history of the islands. An "Appendix" there indeed is, but one utterly unworthy of its reputed author, for the book was edited by a lady (as I have been informed) who had nothing but a few of his notes to guide her, and though assisted, as it is stated, by "the gentlemen connected with that department in the British Museum," is a disgrace to all concerned, since, so far from advancing the knowledge of the subject, it introduced so much confusion as to mislead many subsequent writers.<sup>2</sup> Some years later another great opportunity was missed, and this time by the American traveller Townsend, who, after crossing the Rocky Mountains to the Columbia River, sailed, in company with Nuttall, the well-known naturalist, for the Sandwich Isles, where they arrived in January 1836, and stayed nearly

three months, visiting Oahu and Kauai. Returning at the end of the year, Townsend found the Prussian naturalist Depece at Honolulu, and with him passed some time in the pursuit of natural history, visiting most of the windward islands before he left in March 1837. Among the specimens obtained by Depece for the Berlin Museum were some of two species for which Lichtenstein rightly established a new genus—the singular form *Hemignathus*—and, as it has since proved, both these species were new, though he had, not unnaturally, identified one of them with a species described by Latham. Of Townsend's collection, a considerable part was given to the Academy of Natural Sciences at Philadelphia,<sup>3</sup> where it still remains; but he sent several specimens to Audubon, at that time, I believe, in Edinburgh, and he parted with them to Carfrae, a dealer there, who sold them to the late Sir William Jardine, at the dispersal of whose collection I was so fortunate as to secure them—some of them bearing Townsend's label—for the Museum of this University. If Townsend had but published a list of his captures, he would indeed have rendered a very good service; but of course the value of island-forms, to say nothing of the fact that many of them were threatened with extirpation by colonization and civilization, had not then been appreciated, if even entertained, by naturalists. In the year of Townsend's departure, the French frigate *Venus*, in the course of her troublous career under Du Petit-Thouars, arrived in the Sandwich Islands, with two naturalists, Léclancher and Néboux, on board; and some years later the atlas of plates illustrating the zoology of her voyage appeared; but the text was deferred for a long while, and, indeed, was not completed till 1856. Herein was figured and described, though not for the first time, a third species of the curious *Hemignathus*. In the meanwhile the celebrated expedition of Commodore Wilkes took place, and he, with some of his ships, wintered there. In the course of their six months' stay, the naturalists attached, Pickering and Peale, seem to have made large collections; but nearly all was lost in the shipwreck of the *Peacock*, one of the ships of the squadron. By 1848, Peale had completed his report on the specimens of Mammals and Birds collected, and it was printed off. A few copies only had been distributed, when the rest were destroyed by fire. It was by no means a bad performance; and I cannot understand why the late Mr. Cassin made so many changes in it when he, ten years later, brought out a new edition of it. Some of them (I speak only of those relating to the Sandwich Island fauna) were certainly not improvements. However, a distinctly forward step was made by the Peale-Cassin labours, and since few can obtain access to the original work, I may mention that Dr. Hartlaub considerably published an abstract of it,<sup>2</sup> just as two years later he did<sup>3</sup> of the French "*Voyage au Pôle Sud*," wherein, having sorted out the different species observed by various voyagers on the several Pacific groups, he gave a useful list of those found on each, and thus he assigned to the Sandwich Isles *thirty* species of birds, marking two of them as doubtful. One of them is now known to be rightly included, but the other must be struck out, as well as, for one reason or another, four more—leaving a total of *twenty-five*, only *sixteen* of which are Land-birds and only *fourteen* *Passeres*.

Hitherto, no list of the birds of the Sandwich Isles had been published, so that Dr. Hartlaub's met a great want, though it had, of course, been possible, since 1814, for anyone to pick out for himself the species assigned to that group from the general list compiled by Tidemann

<sup>1</sup> The same negative results attended his second visit in 1824-25.

<sup>2</sup> I have reason to believe that Mr. Bloxam's original notes are still in existence, though hitherto they have not been accessible to me. It is possible that they would remove uncertainty on several points.

<sup>3</sup> In mentioning these facts, I desire to record my deep gratitude to the authorities of both these Museums—Berlin and Philadelphia—for their obliging readiness in allowing me to have these valuable specimens, one of them unique, for examination.

<sup>2</sup> *Archiv für Naturgeschichte*, 1852, Hef. i. pp. 93-138.

<sup>3</sup> *Journal für Ornithologie*, 1854, pp. 160-171.

("Anatomie und Naturgeschichte der Vögel," ii. pp. 426-436), and, in like manner, since 1859, from Mr. G. R. Gray's useful "Catalogue of the Birds of the Tropical Islands of the Pacific Ocean," printed by order of the Trustees of the British Museum, but the former was obsolete, and the latter, as we now know, very erroneous.<sup>1</sup> Mr. Gray's references show him to have been as usual a model of accuracy, but his judgment as an ornithologist was frequently at fault. It was, therefore, with great pleasure that, some time in the winter of 1870-71, I received a copy of a "Synopsis of the Birds hitherto described from the Hawaiian Islands," which had been communicated in February 1869 to the Boston Society of Natural History, by Mr. Dole, a resident in those islands, and had been published in the Society's Proceedings (xii. pp. 294-309); and Mr. Sclater, who I knew had long taken an interest in the ornithology of the group, lost no time in noticing this very important publication (*Ibis*, 1871, pp. 356-362), adding thereto some valuable observations.<sup>2</sup> This list has naturally proved a serviceable foundation for future work. Forty-eight species were included, the author stating that this number "probably comprises but little more than half the avifauna of the group." That the list should be free from error was not to be expected, and a revised version of it, published in the "Hawaiian Almanack and Annual for 1879" (pp. 41-58), corrected some of the mistakes; but it was an honest piece of work, doing credit to its compiler. In the meanwhile, however, the historic voyage of H.M.S. *Challenger* had commenced, and one of the places at which she was to call was the Sandwich Islands. Of course the main object of her voyage was the exploration of the depths of the sea. Nevertheless, the terrestrial zoology of the countries visited, though forming a very subordinate part of the original plan, was not to be wholly neglected—nor was it in this case, for, during the three weeks she stayed in Hawaiian waters (July 27 to August 19, 1875), her officers availed themselves to some extent of the opportunity of studying the ornithology of the islands, though it does not appear that they had received any special instruction in regard to our imperfect knowledge of it. Here, then, was another great chance lost; for had those who drew up the directions for the scientific members of the Expedition taken the trouble to acquaint themselves with the particular points on which investigation was needed, so as to indicate the lines on which further research was desirable, no doubt some one of the *Challenger's* staff would have supplied, even in the short time of her stay, some of the missing facts, or at least would have thrown some light on the subject. As it was, the collection was reported as "small" (24 bird-skins and no specimen in spirit), and "containing nothing absolutely new except a single species of *Anas*," afterwards named *A. wyvilliana*<sup>3</sup> (Proc. Zool. Soc., 1878, p. 350). Something more, however, may yet be expected. The late Prof. Moseley, in his "Notes of a Naturalist on the *Challenger*," states (p. 514) that the last excursion on shore of his colleague, Von Willemon's Suhm, was at Hilo in Hawaii, with a native guide, "in pursuit of the interesting endemic birds," and that "almost the last notes he wrote were some on the Sandwich Islands, relating especially to the birds." These notes do not seem to have been placed at the disposal of

<sup>1</sup> Many of its worst errors are doubtless due to the loss, before mentioned, of the type specimens, which had been suffered by the Museum long before Mr. G. R. Gray was connected with it. Latham, in 1821, had already lamented their decay. It is almost needless to add that such a loss is not now, nor for many years has been, possible.

<sup>2</sup> Mr. Sclater was pleased to remark that this "memoir" had "escaped" my notice as editor of *The Ibis*. Herein he was in error. It certainly did not come to my knowledge while I was discharging that duty, and I doubt whether any copy reached England until after I had laid down my office.

<sup>3</sup> I do not venture to doubt the distinctness of this species, which had before been mentioned as *A. boscas*, var.; but its describer might have shown more clearly wherein it differs from the well-known American *A. obscura*, which seems its nearest ally.

the ornithologists who described the specimens obtained by the *Challenger*; but they can hardly have been destroyed.

Having myself felt a good deal of interest in the avifauna of the Sandwich Isles—which, like that of many other islands throughout the world, was, as I had learnt, threatened with extirpation, chiefly in consequence of the destruction of the forests—I could not fail to be disappointed at the meagre results obtained by our people on this celebrated cruise, when it would have been so easy for them to have done better had their attention been duly called, and I cast about in several directions to find some suitable person to visit the islands with the view of investigating their ornithology in a thorough way. My young friend Mr. Scott Barchard Wilson (son of the well-known Mr. George Wilson, F.R.S.)—of whose taste for natural history I was well assured by his residence in my own College, by his journey to Portugal with Dr. Gadow, and by his subsequent sojourn in Switzerland (*Ibis*, 1887, pp. 130-150)—willingly took up the enterprise, and left Liverpool on February 24, 1887, for Honolulu, where he arrived on April 8, having on his way paid a visit to Washington to confer with Dr. Stejneger, whose name had already appeared in connexion with the birds of the Sandwich Isles. Mr. Wilson stayed in the islands until towards the close of the following year. He brought back such a collection as had never before been made there; but, rich as it was in some respects, defects became apparent as it was gradually worked out, and some of these defects are so grave that, until they are remedied, no complete list of the avifauna can be formed. I am deeply sorry that he has not been able to return; for, with his knowledge of what is wanted, it would be more easy for him to fill up the *lacuna* than anyone else; and I long hoped that he would pay a second visit with this object. However, he has done a great deal more than anybody before him: he has ascertained the precise localities of nearly all the birds hitherto known, and added to them not inconsiderably—fourteen new species or local forms of *Passeres*, two of which required generic acknowledgment—all, it needs not to say, being peculiar to the islands, and mostly to one particular island only. It can scarcely fail to be interesting that the distribution in the group of the different genera and local forms of *Passeres* should be shown, and this is best done by the accompanying table.<sup>1</sup>

But Mr. Wilson was not content, as so many collectors in foreign countries are, with preserving only the skins of the birds he procured. He was careful to obtain specimens in spirit of all the important existing types; and these, having been properly subjected to examination by Dr. Gadow, have led to some remarkable results—the most remarkable that have been as yet made known in regard to the birds of the Sandwich Islands, and perhaps the most remarkable of those published during the past year in regard to Ornithology at large. They are contained in the dissertation I have already mentioned as being contributed by Dr. Gadow to Mr. Wilson's work. Most of the land-birds of the Sandwich Islands had been at one time thought to belong to the *Meliphagidae*, or Honey-suckers—a family very characteristic of the Australian Region, and known to be very polymorphic. It was thought to be still more so; and the surmise had been acted upon, so that some Finch looking birds, *Psittacirostro* and *Loxioides* had been supposed to be Honey-suckers in disguise, and

<sup>1</sup> I have no desire to overlook the services of Mr. Valdemar Knudsen, of Kaula, who sent thence to the United States National Museum several collections, the most important of which was described by Dr. Stejneger in the Proceedings of that institution for 1887 (pp. 75-102), the year of Mr. Wilson's arrival in the islands. The Doctor's paper is of the exhaustive character to which one is accustomed in all his productions, and has been of considerable use in working out Mr. Wilson's collections, while these have enabled the latter to correct several mistakes—under the circumstances quite pardonable—made by the former, who subsequently described in the same Proceedings (xii. pp. 377-386) another collection from the same quarter.

classified accordingly. Dr. Gadow has shown that this supposition is wholly erroneous, and that these last, together with another form, *Chloridops*—one of Mr. Wilson's discoveries—are true *Fringillidæ*; while out of the whole Hawaiian avifauna, only two genera can be referred to the *Meliphagidæ*—namely, *Acrulocercus* (*Moho* of some writers) and *Chætoptila*, the last being presumably

Table showing the Distribution of Birds of the Order PASSERES in the Sandwich Islands.

	Nihoa.	Kauai.	Oahu.	Molokai.	Lanai.	Kaho lawe.	Mau.	Hawaii.
<b>CORVIDÆ.</b>								
<i>Corvus tropicalis</i> ... ..	..	..	..	..	..	..	..	*
<b>FRINGILLIDÆ—</b>								
<i>Psittacirostra psittacea</i> ... ..	..	*	*	*	..	..	..	*
<i>Loxioides bailleui</i> ... ..	..	..	..	..	..	..	..	*
<i>Chloridops kona</i> ... ..	..	..	..	..	..	..	..	*
" <i>Fringilla</i> " <i>anna</i> ... ..	..	..	..	..	..	..	?	*
<b>DREPANIDIDÆ—</b>								
<i>Loxops coccinea</i> ... ..	..	..	..	..	..	..	..	*
" <i>flammea</i> ... ..	..	..	..	*	..	..	..	*
<i>Chrysomitridops caruleirostris</i> ... ..	..	*	..	..	..	..	..	*
<i>Oreomyza bairdi</i> ... ..	..	..	..	..	..	..	..	*
<i>Himatione stajneri</i> ... ..	..	*	..	..	..	..	..	*
" <i>parva</i> ... ..	..	*	..	..	..	..	..	*
" <i>chloris</i> ... ..	..	..	*	..	..	..	..	*
" <i>maculata</i> ... ..	..	..	*	..	..	..	..	*
" <i>chloridoides</i> ... ..	..	..	..	..	*	..	..	*
" <i>montana</i> ... ..	..	..	..	..	*	..	..	*
" <i>kalaana</i> ... ..	..	..	..	..	..	..	..	*
" <i>virens</i> ... ..	..	..	..	..	..	..	..	*
" <i>mana</i> ... ..	..	..	..	..	..	..	..	*
" <i>sanguinea</i> ... ..	..	*	*	*	*	*	*	*
" <i>doli</i> ... ..	..	*	*	*	*	*	*	*
<i>Vestiaria coccinea</i> ... ..	..	*	*	*	*	*	*	*
<i>Drepanis pacifica</i> ... ..	..	..	..	..	..	..	..	†
<i>Hemignathus procerus</i> ... ..	..	..	..	..	..	..	..	*
" <i>lichtensteini</i> ... ..	..	..	..	..	..	..	..	*
" <i>obscurus</i> ... ..	..	..	..	..	..	..	..	*
" <i>hanapepe</i> ... ..	..	*	..	..	..	..	..	*
" <i>lucidus</i> ... ..	..	..	*	..	..	..	..	*
" <i>olivaceus</i> ... ..	..	..	..	..	..	..	..	*
<b>MELIPHAGIDÆ—</b>								
<i>Acrulocercus braccatus</i> ... ..	..	..	*	..	..	..	..	*
" <i>apicalis</i> ... ..	..	..	?	..	..	..	..	*
" <i>nobilis</i> ... ..	..	..	..	..	..	..	..	*
<i>Chætoptila angustipluma</i> ... ..	..	..	..	..	..	..	..	†
<b>TURDIDÆ (?)—</b>								
<i>Pheornis myiadestina</i> ... ..	..	..	*	..	..	..	..	*
" <i>lanaiensis</i> ... ..	..	..	..	?	*	..	..	*
" <i>obscura</i> ... ..	..	..	..	..	..	..	..	*
<b>MUSCIPAPIDÆ—</b>								
<i>Chasiempis</i> (quædam species non determinatæ) ... ..	..	*	*	*	*	*	*	*

All the species above-named are peculiar to the group, i.e. not found elsewhere. A \* indicates that the species inhabits the island whose name heads the column. A † shows that the species is believed to be extinct.

extinct. All the other forms which had been accounted Meliphagine, present a peculiar structure of tongue, forbidding that alliance, or any affinity to the *Prionopida*, *Dicaeida*, or *Nectariniidæ*, but revealing a distinct relationship to the *Cærebida*—now known as a Family characteristic of the Neotropical Region! Hereby a beam of light is thrown on the origin and derivation of the ornithic population of the Sandwich Islands. The

distinct inference is that the first stock of their existing avifauna was received from America, in days when the range of the *Cærebida* extended further to the northward than it does at present, and that certain cognates or ancestors of the present *Cærebida* colonized the islands, there differentiating into the modern *Drepanididæ*. The importance of this inference on views which are held as to the Geographical Distribution of Birds in North America is a subject into which there is no need here to enter, for that would be a subject foreign to my present remarks; but I doubt not it will receive due attention from American ornithologists, whom it most nearly concerns. That these colonists from what I would venture to term a "Columbian" fauna—since it cannot be literally called a Neotropical one, and is certainly not "Nearctic"—were the earliest settlers which have left descendants one can hardly doubt, for they have existed in the Sandwich Islands long enough to undergo a great amount of change. Subsequently there has been a small infusion of blood from the "Australian Region." I say subsequently, because Dr. Gadow has shown that this immigration has undergone comparatively little modification. We have (or had) the two Meliphagine genera, *Acrulocercus* and *Chætoptila*—the latter, indeed, beyond anatomical examination, but showing no very great external deviation from well-known Australian types; while the former undoubtedly retains the normal Meliphagine tongue. To these may be added *Chasiempis*, a well-marked genus; but, without question, very nearly allied to the genus *Rhipidura*, so widely spread over the Australian Region, and found also in New Zealand. Thus three genera constitute, so far as I am able to see, the "Australian" element in the avifauna of the Sandwich Islands—and what are they among so many others? More recently than this Australian infusion, has supervened an influx of Holarctic types, and especially of the *Fringillidæ*. Whether these have arrived from America or Asia, I do not pretend to say; but the long chain of islets running to the westward—one of which produces a remarkable form (*Telespiza cantans*), the knowledge of which we also owe to Mr. Wilson (*Ibis*, 1890, pp. 339-341, Plate ix.)—suggests the possibility of an Asiatic origin, a possibility confirmed by the consideration that his fine *Chloridops kona* may be the magnified descendant of the long-known *Chloris kawarabiba*, which has already an enterprising relative, *C. kittlitzii* (*Ibis*, 1890, p. 101), established in the Bonin Islands. Still later must have been the appearance on the scene of members of the genera *Corvus* and *Buteo*, both of which are, so far as is yet known, confined to Hawaii, the most eastern of the islands, and therefore suggest an emigration from the Nearctic area. These have been settled long enough to assume recognizable specific characters; but an apparently more modern colonist exists in *Asio accipitrinus*, the common Short-eared Owl of Asia, Europe, and North America, which extends its range over many islands in the Pacific Ocean, so far at least as the Galapagos, and has found a permanent home in the Sandwich Isles, breeding there, as it would seem, regularly—as it once did in England, and would again, if permitted by the gamekeepers. More than this, there is an indication that the tendency to colonization from the Holarctic region still continues. Within an hour or two of his leaving the islands, there was sent to Mr. Wilson a freshly-killed example of *Circus hudsonius*—the American Hen-Harrier—a species which he had already ascertained to have before occurred in the group; but, not being recognized by Judge Dole, it had been endowed with a new name, and figures in his second list as *Accipiter hawaii*. The existence in considerable numbers of a Californian species of *Carpodacus* is thought, and no doubt rightly, by Mr. Wilson to be

† In connexion herewith may be noticed the absence of Parrots, Kingfishers, and Doves—all Families that are very characteristic of an "Australian" Fauna.

due to human agency, and accordingly I do not attach any importance to the fact; but there is one very puzzling species, of which only a few specimens seem to have been preserved, that needs particular attention. This was described by Judge Dole under the name of "*Fringilla anna*," but, of course, is no true *Fringilla*. Mr. Wilson brought home but a single specimen, which he owed to the kindness of the Hon. C. R. Bishop, it having been formerly in the Mills Collection; and, I believe, will establish for it a new genus, *Ciridops*—so named because its bright coloration recalls the well-known *Emberiza civis* of Linnaeus, the Painted Bunting of authors, or "Nonpareil" of bird-dealers. It is supposed to be now extinct, but it was a truly native species; it probably belongs to the fauna which I have above called "Columbian" (for want of a better name); but I cannot suppose it to have been so early a settler as the *Drepanididae*, since it has changed so little. On the genus *Chasiempis* I would offer only one remark, and that is a word of caution to those who would, on the evidence of from a couple to half-a-dozen of specimens, or perhaps even on the evidence of a badly-coloured plate, attempt to break it up into definable "species." There remains of land-birds the genus *Phaormis*, which earlier systematists were inclined to put among the Flycatchers (*Muscicapidae*). The examples in spirit, placed by Mr. Wilson at Dr. Gadow's disposal, have enabled the latter to set aside that view, and to show that, of all the Families to which this genus has been supposed to be allied, "it differs least from the *Turdidae*," and he would regard it "as a generalized or rather primitive Thrush."<sup>1</sup>

Of the water-birds I do not now propose to speak. Though possessing very many points of special interest to the ornithologist, so far as I understand them they throw no particular light on the general questions I have attempted to consider; and I would conclude this sketch of the Ornithology of the Sandwich Isles by referring to the unhappy fate of one of the most beautiful of their birds—the "Mamo," as I am told it was latterly called—*Drepanis pacifica*, one of the rarest species in collections, and apparently wholly extinct. Until Mr. Wilson brought the specimen which he has kindly given to this University, there seems not to have been one in the British Islands since the dispersal of the Leverian Museum, when two were bought by the Austrian agent, and are now at Vienna. How many other specimens may exist in the world I do not know, but the number can hardly exceed half-a-dozen. The bird was destroyed for the sake of its rich yellow feathers, used in former days to decorate the state robes of the chiefs, and according to all accounts a glorious sight one of those robes when in all its freshness must have been. As the species became scarce, recourse was had to the yellow tufts of *Acrulocercus nobilis*, which in depth of colour are very inferior; and when the *Drepanis* had ceased to exist, the name "O-o," which it seems to have borne in Cook's days, was transferred to the surviving species, according to a practice of which I have observed several instances in other nations. The general similarity of coloration in *Acrulocercus* and *Drepanis* is, indeed, obvious, and Dr. Gadow is inclined to consider the latter to have been the imitating form. If so, its mimicry has proved its destruction; but it clearly could not have foreseen that fashion should ordain its acquired yellow and black feathers to become desirable commodities among the human race, and it would be well to suspend judgment on this point. It had most likely a very limited range, which would, of course, hasten its end; and its two most conspicuous relatives, the scarlet *Vestiaria coccinea*, and the crimson *Himatione sanguinea*, though in equal request for their gaudy plumage, still exist, inhabiting (as will be seen by the table) all the islands that have been examined. How to account for

<sup>1</sup> A minute comparison with the New-Zealand *Turnagra*, if that be still in the land of the living, would be desirable.

the disappearance of *Chctoptila angustipluma* is beyond my power. It has no attractive colouring, and yet is declared to be extinct. The specimen given to us by Mr. Wilson is, I believe, the only one ever brought to Europe, and there seems to be but one (the type) in any American Museum. In mentioning the former I must acknowledge gratefully the generosity of Mr. Wilson, who promised a complete set of his bird-skins to the Museum of his old University on the completion of his work, a promise that he will doubtless perform.

Finally, I would point out that the conclusions established by Dr. Gadow's researches seem to coincide very much with those arrived at by Dr. David Sharp and Mr. Blackburn from their investigation of a small collection of Hawaiian *Coleoptera* (Trans. Roy. Dublin Society, series 2, vol. iii. Part 6). The entomological captures of Mr. Perkins are therefore awaited with considerable interest; and still more valuable, perhaps, may be his conchological collections, for it seems doubtful at present whether the Mollusks of the Sandwich Isles can be brought into line with their Birds and their Beetles. There is every chance of this question, among many others of importance, being solved if Mr. Perkins is enabled to prolong his stay for sufficient time; but that depends upon the financial support he may receive at home from the two learned bodies which I have mentioned, and from the Hawaiian Government and influential residents in the Islands.

ALFRED NEWTON.

Cambridge, 13 February, 1892.

#### PROF. BUNSEN AND THE CHEMICAL SOCIETY.

IT was announced at the last meeting of the Chemical Society that it was proposed to present the following address to Prof. Bunsen, who has now been fifty years a Foreign Member of the Society; and the wish was expressed that, among those who sign it, all who have been his pupils should, as far as possible, be included. Fellows of the Society who have been pupils of Prof. Bunsen are requested to communicate with the Senior Secretary before March 19, in order that they may receive a form for signature.

To Privy Councillor Prof. Bunsen, Fellow of the Royal Society.

YOUR EXCELLENCY,—Fifty years have elapsed since the Chemical Society of London honoured itself by electing you one of its Foreign Members. Your name, and that of your illustrious fellow-countryman Liebig, are, in fact, first on a list which includes the most distinguished cultivators of chemical science in every civilized country of the world.

Our Society remembers with gratitude that you enriched the first volume of its Transactions by communicating to it the results of your ever-memorable investigation of cacodyl and its compounds. That you should have sent to us, in the first and most critical year of our existence, a memoir which the chemical world will ever regard as one of the classics of our science, is a significant proof of the beneficent interest with which you regarded our efforts to foster the growth of chemical learning in this country.

Your masterly investigations, in collaboration with our Fellow, Sir Lyon Playfair, on the gases evolved from iron furnaces, made by methods which you were the first to bring to perfection, greatly extended our knowledge of the theory of the smelting of iron. By the permanent benefit thus conferred on one of the most important of our industries, you have largely augmented our national wealth.

The half-century during which you have been associated with our Society has been fruitful in great dis-

coveries and important inventions. It has witnessed the birth of new elements, the creation of new analytical methods, and an extraordinary development in the instrumental resources of our laboratories. Chemists will never forget that it is to your unwearied assiduity and single-minded devotion that science owes some of the most momentous of these discoveries, and some of the most valuable of these inventions. Your investigations will ever be regarded as models of the highest type of scientific research, and the memoirs in which you have embodied them shed an imperishable lustre on our literature. Your methods of analysis are among the most common of our manipulative operations, and the very furniture and instruments of our laboratories are an ever-present testimony to the obligations under which experimental chemistry will always remain to you.

Many of our members are proud to be numbered among your pupils, and those among them who have become teachers, have, we trust, caught and transmitted something, not only of the method, but also of the spirit, in which they themselves were taught. They have an abiding memory of your kindness, of your constant and unselfish devotion to their interests, and of the generous sympathy and ready help which you extended to their efforts to enlarge the boundaries of our science.

We, the undersigned Fellows of the Chemical Society of London, now beg to offer you our heartfelt felicitations on the occasion of your Jubilee as a member of our body. It is our fervent hope that you may be able, for many years to come, to enjoy in health and happiness the leisure and repose which you have so justly and so honourably earned.

#### NOTES.

THE course taken by the Government with regard to a Teaching University for London has met with general approval. The proposed Charter, if it had been accepted, would have done almost irreparable injury to the cause of higher education in the capital. Now we have got rid of it, and the way is clear for new and more carefully considered schemes. The Royal Commission to which the question is to be referred will be free, if it chooses, to examine the question whether, after all, the institution needed by London might not be most readily and most effectually obtained by the development of the existing University. It may be hoped that on this and all other aspects of the question full evidence will be taken. What is wanted is that any recommendations which may be made by the Commission shall be based on extensive and accurate information as to the organization and the proper functions of Universities. On this subject some very crude notions are still current in England.

THE sixth annual Photographic Conference in connection with the Camera Club will be held in the theatre of the Society of Arts, on Tuesday and Wednesday, March 22 and 23, under the presidency of Captain W. de W. Abney, F.R.S. All photographers are invited to take part in the Conference.

THE Botanical Society of France will hold an extraordinary meeting at Biskra, Algeria, during the first half of April.

A ROYAL COMMISSION has been appointed to consider the question of the water supply of London. Its task will be to inquire whether the present sources of supply are adequate in quantity and quality, and, if inadequate, whether such supply as may be required can be obtained within the watersheds of the Thames and the Lea, or must be obtained elsewhere. Among the members of the Commission are Sir Archibald Geikie and Prof. James Dewar.

A NUMBER of gentlemen, representing institutions interested in science-teaching, recently applied to the Vice-President of the Committee of Council on Education for permission to wait upon him with reference to the changes indicated in the circular issued by the Department of Science and Art, dated November 12, 1891. In answer to a question put by Mr. Schwann, Sir W. Hart Dyke stated in the House of Commons, on Tuesday evening, that he had informed the deputation that he did not think any good purpose would be served by his receiving them. He was, however, willing to reconsider the matter. Sir William expressed his belief that the changes announced in the circular would greatly stimulate more advanced scientific instruction. The minute had been well received in the better schools.

A NEW "Jahrbuch der Chemie" is to be issued by the German publisher, H. Behhold, Frankfurt. It will be edited by Prof. R. Meyer, who has secured the co-operation of many eminent men of science. The intention is that the progress of pure and applied chemistry shall be recorded every year in a connected series of articles.

DR. M. C. COOKE announces that, with the next number of *Gravillea*, his connection with it as editor and proprietor will come to a close, and it will rest with others whether the journal is to be continued. *Gravillea* is "A Quarterly Record of Cryptogamic Botany and its Literature." With the next number it will have completed its twentieth volume.

DR. B. ARTHUR WHITELEGGE will begin at the Royal Institution, on Thursday, March 24, a course of three lectures on epidemic waves. In the first lecture he will deal with cyclic waves; in the second (March 31), with superadded waves; in the third (April 7), with pandemic waves.

THE fifth ordinary meeting of the Egypt Exploration Fund was held last Friday, Sir John Fowler presiding. The balance-sheet was one of the most satisfactory ever presented to the members. The Fund, it was pointed out, was now used in two classes of operations—surveying and excavating; and both "seemed likely to be very successful." In the course of a brief discussion on the report, reference was made to "the generous contributions which had been handed to the Fund from America, in comparison with those received from England."

THE half-yearly general meeting of the Scottish Meteorological Society was held at Edinburgh on Monday, March 7. The following was the business:—(1) Report from the Council of the Society; (2) changes in the temperature of Scotland since 1764, by Dr. Buchan; (3) on the squall of February 1, 1892, by R. C. Mossman; (4) sunshine values at the Ben Nevis Observatory, by R. C. MOSSMAN.

MR. E. J. STONE, F.R.S., and Mr. A. G. Vernon Harcourt, F.R.S., have been elected members of the Athenæum Club, under the rule which provides for "the annual introduction of a certain number of persons of distinguished eminence in science, literature, or the arts, or for public services."

THE fifteenth Convention of the National Electric Light Association, lately held at Buffalo, U.S., seems to have been unusually successful. This is attributed by the American journal *Electricity* to the fact that at previous meetings members attended "not for business but for pleasure." The counter-attractions were so varied and fascinating that it seems to have been difficult "to obtain a creditable attendance on the reading of the papers and the transaction of business." "The plan of doing away with these outside attractions," says *Electricity*, "was therefore an experiment, but so successful did it prove in this instance, that this last Convention will go down in history as 'the business Convention,' unless the increased success of succeeding meetings shall make it necessary to give this one the more specific title of 'the first business Convention.'"



THE Natural History Society of Buda-Pesth is stated to number 7800 members. A special botanical meeting of the Society will in future be held monthly, under the presidency of Prof. Juranyi.

THE section of vegetable pathology of the botanical division, in the U. S. Department of Agriculture, was recently made a separate division by Act of Congress. The authorities of the new division decided to begin a fresh series of publications; and they have taken the first step towards the fulfilment of their purpose by the publication of an important *Bulletin*, by Dr. E. F. Smith, presenting "additional evidence on the communicability of peach yellows and peach rosettes."

JAPAN has no fewer than 700 earthquake-observing stations scattered over the Empire, and the Tokio correspondent of the *Times* is of opinion that they are all needed. He points out that not only are the Japanese shaken up by fully 500 earthquakes every year—some of them more or less destructive—but at intervals there comes a great disaster, amounting, as in the earthquake of October 28, 1891, to a national calamity. Japanese annals record twenty-nine such disasters during the last 1200 years.

A SEVERE earthquake shock, lasting twelve seconds, was felt at Napa, California, on March 13, at 8.30 a. m. The direction of the vibration was from north to south.

A CORRESPONDENT at Leon writes to us of an earthquake which was felt in Nicaragua on February 6. He speaks of a connected series of longitudinally oscillating progressive seismic waves, which lasted about ninety-two seconds. They were parallel with, and near, the cones and masses of volcanic ejecta which extend, with some interruptions, between the volcanic groups in the States of Salvador and Costa Rica. The earthquake began at 10.10 p. m.

PROF. HELLMANN, of Berlin, to whom we are indebted for many painstaking investigations into the origin of meteorological instruments and observations, has contributed to the *Zeitschrift für Luftschiffahrt* for January an article on the first balloon voyage made for scientific purposes. The works on the subject of ballooning, of which there are many, state that the first was by Robertson and Lhoëst in 1803, and the next in the following year, by Biot and Gay-Lussac. But this is not correct; the honour undoubtedly belongs to Dr. John Jeffries, of Boston (Mass.), who had for some years lived in this country. In 1786 he published a book (60 quarto pages and 2 plates), entitled, "A Narrative of the Two Aërial Voyages of Dr. Jeffries with Mons. Blanchard; with Meteorological Observations and Remarks." The first voyage was on November 30, 1784, from London to Dartford (Kent), and the second, on January 7, 1785, across the English Channel. A paper containing the results was read before the Royal Society in January 1786. The barometer taken was made by Jones, of Holborn, and read to 18 inches. The heights reached in the two voyages were about 9200 feet and 4500 feet respectively. The latter height was obtained trigonometrically by an officer at Calais, while the balloon lay stationary over the mid-Channel.

THE *Record of Technical and Secondary Education*, published monthly, can scarcely fail to be of service to all who interest themselves in educational progress. The number for March includes, besides editorial notes, accounts of County Council schemes and reports, scholarship schemes, recent progress in various districts, agricultural college for the south-eastern counties, and the financial management of the technical instruction fund. There are also instructive "miscellaneous."

A WRITER in the *Mediterranean Naturalist* for March notes that no attention has hitherto been given to the fact that

certain species of birds prefer certain trees. Hé says:—"It is a remarkable fact that, notwithstanding the voluminous literature that has been written on birds and their habits, no writer has noticed the preference that certain species of birds give to certain trees. Jays and rooks are found in the greatest number in oak-trees; finches, in lime-trees; and black-caps among laurels. The nightingale is always found in the greatest numbers in nut-groves, while the thrush evinces a decided preference for the birch and ash. The beech is the favourite tree of the woodpecker; and the numerous families of tits are generally found in the greatest abundance among the blackthorn."

MR. W. M. GOLDTHWAITE, New York, is publishing a new monthly magazine called *Minerals*. The second number has been sent to us. It contains many short papers, in which interesting facts relating to various classes of minerals are presented in a bright and popular style.

MESSRS. J. AND A. CHURCHILL have issued a fifth edition of Dr. A. Tucker Wise's "Alpine Winter in its Medical Aspects." The work has been condensed and rewritten in many places.

THE U. S. Commissioner of Education has issued his Report for the year 1888-89, and, if it cannot be described as light reading, it is certainly a most instructive and useful work. It consists of two large volumes, and includes a number of chapters in which education in the United States is compared with that of England, France, Germany, and other countries. A full account is also given of normal schools, manual training schools, courses of study, &c. The second volume consists of "detailed statistics of educational systems and institutions, with comments and discussions."

THE peculiar milk-ferment known as "kefir" or "kephir" has been supposed to be peculiar to the Caucasus and other parts of Eastern Europe and Western Asia. Mr. C. L. Mix has found a yeast apparently identical with it in use in Canada and the United States. It occurs in the form of small granules of a dirty brown colour, which retain their vitality for a long period, and consist of a small proportion of yeast-cells embedded in zoogloea-like masses of rod-shaped bacteria. The yeast-cells increase by budding, and no formation of spores has been detected in them. They do not invert cane-sugar like ordinary beer-yeast, but they cause alcoholic fermentation in milk-sugar or lactose and in dextrose, not in cane-sugar or saccharose. The bacteria are short cylindrical rods with homogeneous protoplasm, developing under cultivation into leptothrix-like filaments in which spores are formed. They appear to take no part in the fermentation, remaining almost entirely embedded in the zoogloea-masses during the process.

HERR W. BELAJEFF has communicated to the *Berichte* of the German Botanical Society a paper on the "Pollen-tube of Gymnosperms," which, if his observations—made on *Taxus* and *Juniperus*—are confirmed with regard to other members of the class, will greatly modify the accepted view as to the morphology of the different parts of the pollen-grain. Hitherto, the two or three small cells in the pollen-grain have been regarded as a survival of the male prothallium of the microspore. Belajeff shows that this cannot be the case, as they are cut off in succession from the large cell. Moreover, he states that it is not, as is usually supposed, the nucleus of the large cell which fertilizes the oosphere in the archegone, but the nucleus of one of the small cells. When the pollen-tube begins to develop, one of these small cells becomes detached and wanders down the tube. Its membrane becomes absorbed; its nucleus overtakes that of the large cell and divides into two; and it is one of these two daughter-nuclei of the wandering small cell, together with

the protoplasm which surrounds it, that fuses with the nucleus of the oosphere in the archegone. The other small cell becomes entirely disorganized.

It sometimes happens that peat bogs swell and burst, giving out a stream of dark mud. Herr Klinge has made a study of this rare phenomenon (*Eot. Jahrb.*), of which he has found only nine instances, in Europe, between 1745 and 1883 (seven of these being in Ireland). Heavy rains generally occur before the phenomenon, and detonations and earth vibrations precede and accompany it. The muddy stream which issues, of various fluidity, rolls along lumps of peat, and moves now more quickly, now more slowly. After the outbreak, the mud quickly hardens, and the bog sinks at the place it appeared, forming a funnel-shaped pool. The bogs considered by Herr Klinge have been almost all on high ground, not in valleys. He rejects the idea that the effects are due to excessive absorption of water by the bog. The peat layers, which often vary much in consistency, have each a certain power of imbibition, and the water absorbed does not exceed this limit. Excessive rain affects chiefly the upper layer not yet turned into peat and the cover of live vegetation, which get saturated like a sponge, after which the water collects in pools, and runs off in streams. The theory of gas explosions is also rejected; and the author considers the real cause to lie in land-slips, collapses, &c., of ground under the bog, permitting water or liquid mud to enter. This breaks up the bog mechanically, mixes with it and fluidifies it, and an outburst at the surface is the result. The limestone formations in Ireland, with their large caverns and masses of water, are naturally subject to those collapses, which, with the vibrations they induce, are more frequent in wet years. The heavy rains preceding the bog eruptions are thus to be regarded as only an indirect cause of these. Herr Klinge supposes that similar eruptions occurred in past geological periods, e.g. the Carboniferous, in some cases where fossil tree-stems are found in upright position.

THE geographical position of Mount St. Elias is of considerable popular interest in connection with the boundaries of Alaska. Mr. Israel C. Russell refers to the subject in a report published in the new number of the American *National Geographic Magazine*. In the convention between Great Britain and Russia, wherein the boundaries of Alaska are supposed to be defined, it is stated that the boundary, beginning at the south, after leaving Portland Channel, shall follow the summit of the mountains situated parallel to the coast as far as the 141st meridian, and from there northward the said meridian shall be the boundary to the Arctic Ocean. Whenever the summit of the mountains between Portland Channel and the 141st meridian "shall prove to be at the distance of more than ten marine leagues from the ocean, the limit between the British possessions and the line of coast which is to belong to Russia, above mentioned, shall be formed by a line parallel to the windings of the coast, and which shall never exceed the distance of ten marine leagues therefrom." As Mount St. Elias is approximately in longitude  $140^{\circ} 55' 30''$  west from Greenwich, it is therefore only  $4' 30''$  of longitude, or  $2\frac{1}{2}$  statute miles, east of the boundary of the main portion of Alaska. Its distance from the nearest point on the coast is 33 statute miles. There is no coast range in South-Eastern Alaska parallel with the coast within the limits specified by the treaty, and the boundary must therefore be considered as a line parallel with the coast, and ten marine leagues, or  $34\frac{1}{2}$  statute miles, inland. The mountain is thus  $1\frac{1}{2}$  miles south of the boundary, and within the territory of the United States. Its position is so near the junction of the boundary separating South-Eastern Alaska from the North-West Territory with the 141st meridian, that it is practically a corner monument of the American national domain.

A NEW and very simple mode of synthesizing tartaric acid has been discovered by M. Genvesse, and is described by him in the current number of the *Comptes rendus*. It will doubtless be remembered that, some years ago, Dr. Perkin and Mr. Duppa prepared tartaric acid artificially by treating di-brom-succinic acid with hydrated oxide of silver, and this operation became the final stage of a complete synthesis from the elementary constituents, when, a short time afterwards, Prof. Maxwell Simpson succeeded in preparing succinic acid by the action of caustic potash upon the di-cyanide of ethylene. M. Genvesse now shows that tartaric acid may be directly synthesized by the action of nascent hydrogen upon glyoxylic acid,  $\text{CHO}-\text{COOH}$ , the curious compound, half aldehyde, half acid, derived from glycol, and hence directly from ethylene. If we double the formula of this acid, and add two atoms of hydrogen, we arrive at tartaric acid,  $\text{COOH}-\text{CHOH}-\text{CHOH}-\text{COOH}$ , and this is found to be capable of realization by reacting upon glyoxylic acid with nascent hydrogen liberated in its mist by the action of acetic acid upon zinc dust. A mixture of glyoxylic and acetic acids, the latter diluted with an equal weight of water, in the proportion of one molecule of glyoxylic to three molecules of acetic acid, was treated in small quantities at a time with zinc dust, at first at the ordinary temperature, and finally over the water-bath. The liquid was then filtered, and the zinc in solution removed by means of potassium carbonate. The clear liquid was then mixed with calcium chloride solution, and after removal of any calcium carbonate precipitate, a white crystalline precipitate commenced to separate. This precipitate was found to yield all the reactions of a tartrate, such as silvering glass when gently warmed with ammonia and silver nitrate. Its analysis gave numbers indicating the formula  $\text{C}_4\text{H}_4\text{CaO}_6 + 4\text{H}_2\text{O}$ , which is the composition of ordinary tartrate of lime. By treating this salt with the calculated quantity of sulphuric acid diluted with twenty times its volume of water, filtering off the precipitated calcium sulphate and evaporating the filtrate over oil of vitriol, the acid itself was obtained in large crystals. It is interesting to find that the tartaric acid obtained by this mode of synthesis is the optically inactive variety known as racemic acid, there being apparently equal numbers of molecules of both the dextro and levo varieties produced. The crystals consequently do not show hemihedral faces; the angles observed corresponded with those observed by Provostaye and by Rammeisberg in the case of racemic acid. It may be remarked that, as the product of the synthesis of Dr. Perkin and Mr. Duppa, a mixture of racemic acid with the truly inactive tartaric acid, in which neutralization within the molecules themselves occurs, was obtained. This new synthesis of tartaric acid from glyoxylic acid would appear to throw some light upon the natural formation of tartaric acid. For, remembering the close relationship between glyoxylic and oxalic acids, which latter we know to be one most readily formed in vegetable tissues, and the reducing agencies which appear to be connected with chlorophyll, we have all the means at hand to account, in view of the work of M. Genvesse, for the natural synthesis of tartaric acid.

THE additions to the Zoological Society's Gardens during the past week include a Common Squirrel (*Sciurus vulgaris*), British, presented by Mrs. Crick; a Merlin (*Falco aesalon*), European, presented by Mr. T. A. Cotton; a Blue Titmouse (*Parus caeruleus*), British, presented by Captain Salvin; two Blossom-headed Parakeets (*Palaeoreus cyanocephalus*) from India, presented by La Comtesse Cottrell; a Green Monkey (*Cercopithecus callitrichus*  $\delta$ ) from West Africa, deposited; a Hawk (*Asurina* sp. inc.) from South America, purchased; four Yellow-bellied Liothrix (*Liothrix luteus*) from India, received in exchange; sixteen Puff Adders (*Vipera arietans*), born in the Gardens.

OUR ASTRONOMICAL COLUMN.

SOLAR INVESTIGATIONS.—*Astronomy and Astro-Physics* for February contains a short note by Prof. Hale, to the effect that photographs have been taken at Kenwood Observatory, showing the H and K lines reversed in regions widely distributed over the sun's disk. These regions closely resemble faculae in appearance.

At the meeting of the Paris Academy on March 7, Prof. Tacchini communicated a paper on the distribution in latitude of the solar phenomena observed at the Royal Observatory of the Roman College during the second half of last year. Prominences have been more frequent in the northern hemisphere than in the southern, although in the preceding half-year, and in 1889 and 1890, they were more frequently observed in the southern solar hemisphere. The zones of maximum frequency occurred between latitudes 40° and 60°. Faculae also have been most numerous north of the equator, and the zone of maximum frequency of these phenomena appears to be between latitudes 10° and 30°. Spots have been most abundant north of the equator, with a maximum frequency in the same zones as faculae.

In the *Comptes rendus* containing Prof. Tacchini's results, occurs also a note by J. Fényi, on a remarkable prominence observed at Kalocsa, on February 19, as the recent large spot-group was passing over the sun's limb.

NEW DOUBLE STAR, 26 AURIGÆ.—In a communication to the *Astronomical Journal*, No. 256, Mr. S. W. Burnham records the discovery that 26 Aurigæ is a close double star, made up of two nearly equal components. His measures of position-angle and distance for 1892.0 are 344°.4 and 0".15; and of magnitudes, 5.6 and 6.0. The distance very probably never exceeds a quarter of a second, or the duplicity of the star would have been noticed by many observers of the distant companion discovered by Herschel in 1783.

ROTATION OF JUPITER.—Writing in the March number of the *Observatory*, Mr. Denning notes that his observations of one of the chief dark spots in Jupiter's north temperate belt, for the period from August 21 to November 3 (180 rotations), gave the mean period of rotation 9h. 49m. 36.9s. Observations of the red spot, from August 7 to February 2 (432 rotations), indicate a mean period of 9h. 55m. 42.2s. The value obtained during the opposition of 1890 was 9h. 55m. 40.2s., so that the motion of rotation of the red spot would appear to have slackened by two seconds. Since the period of rotation derived from this spot is now 6m. 5s. longer than that given by the dark spots on the north temperate belt, the latter revolves around Jupiter, relatively to the former, in 40½ days.

THE NEW STAR IN AURIGA.—In No. 3078 of the *Astronomische Nachrichten* are recorded three communications relative to this Nova, two of which refer to its position, while the third deals with its spectrum. The observations of the last-named were made at the Astro-physical Observatory in Héreny, Ungarn, by Herrn Eugen and Gothard, previous to February 15. On the 10th and 13th of the same month the following lines were observed:—

Bright lines.	February 10.		February 13.	
	Wave-lengths in micro-millimetres.		Wave-lengths in micro-millimetres.	
I. ... ..	654.2	...	...	...
II. ... ..	532.2	...	530.3	...
III. ... ..	513.2	...	516.8	...
IV. ... ..	501.9	...	501.9	...
V. ... ..	492.3	...	492.3	...
VI. ... ..	486.6	...	486.2	...
VII. ... ..	439.0	...	...	...
End of spectrum	412.0	...	...	...

In the first series of observations, the authors give suggestions for some of the lines, and for comparison's sake we have added Mr. Lockyer's also, both of which are included in the following table:—

Wave-lengths.	Origin.	Lockyer.
532.2	Chromosphere line (531.7)	— (531.3)
501.9	Nebula-line (500.5)	Mg (500.6)
486.6	Hydrogen line Hβ	H (486.1)
439.0	" " Hγ	— —

In the second series comparisons were made with Geissler's tubes, and the following measurements were made:—

	Geissler Tubes.		Nova.	
IV. ... ..	500.6	...	501.9	...
V. ... ..	492.6	...	492.3	...
VI. ... ..	486.2	...	486.2	...

THE LICK SPECTROSCOPE.—The February number of *Astronomy and Astro Physics* contains an excellent plate, taken from a photograph by Mr. Barnard, of the spectro-scope on the great 36-inch refractor of the Lick Observatory. In the description of the instrument it is stated that the spectro-scope itself is no less than 130 pounds in weight, while the two brass rods which connect it to the telescope form an extra addition of 75 to 80 pounds. Accompanying the plate, which shows the general arrangement of its parts, is a plan of the instrument which is completely described in the text. Many ingenious ideas have been displayed in the completion of the instrument as regards accessories, such as that of the lighting up of the pointers and production of the comparison-spark. Owing to the great focal length of the telescope, only 1.06 inch of the full aperture of the spectro-scope can be used, but when it is dismounted, it rests on a truck, and its full aperture, 1.50 inch, is then available for laboratory work.

A BRIGHT COMET.—A circular from the Royal Observatory, Edinburgh, communicated by Dr. Ralph Copeland, and dated March 11, contains the following information of the appearance of a bright comet:—

Dr. L. Swift discovered a bright comet at Rochester, N. Y., at 16h. 50.1m. local mean time, on March 6, its place then being R.A. 18h. 59m., South Declination 31° 20'. It was moving eastwards.

The exact place of the comet was observed at the Royal Observatory, Cape of Good Hope, on the 8th inst. to be:—

Cape of Good Hope Mean Time	...	16h. 58m. 36s.
Right Ascension	...	19h. 2m. 27.8s.
South Declination	...	30° 2' 54"

*Astronomische Nachrichten*, No. 3079, also contains some information with regard to this comet. A telegram from Boston contained the following: "Comet Swift was observed by Barnard, March 8.0399 G.M.T.; R.A. app. = 285° 51' 20", Polar Distance = 120° 32' 53". Comet is visible to the naked eye."

Another telegram from Capetown read: "Comet was observed March 9.6024 G.M.T.; Right Ascension = 287° 45' 50", P.D. app. = 119° 16' 12". R.A. March 8 read, 286° 36' 57" instead of 285° 36' 57"."

Prof. H. Kretz in the same number gives the following elements and ephemeris:—

Elements.

T = 1892 March 26.8545 Berlin M.T.

$$\begin{aligned} \omega &= 9^{\circ} 57' 21'' \\ \Omega &= 239^{\circ} 33' 76'' \\ i &= 33^{\circ} 38' 44'' \end{aligned} \left. \begin{array}{l} \\ \\ \end{array} \right\} \text{M. Eq. 1892.0}$$

log. q = 0.02208.

Ephemeris for 12h. Berlin M.T.

1892.	h.	m.		s.
		h.	a.	
March	9	...	19 10	25.9
	13	...	29 13	25 57.8
	17	...	46 57	22 22.0
	21	...	20 3 41	18 39.0
	25	...	19 26	14 52.6
April	29	...	34 17	11 5.9
	2	...	20 48 19	7 21.9

CALCULATION OF TRAJECTORIES OF ELONGATED PROJECTILES.

AS the correct determination of the law of resistance of the air to the motion of elongated projectiles is a matter of considerable national importance, I hope you will allow me to offer a few concluding remarks explanatory of the present state of the case. Some results of my first systematic experiments were published in 1868, and General Mayevski, after applying a few tests of his own, adopted my results in his "Traité de Balistique Extérieure," 1872. Siacci made use of these results in

his ballistic tables (1881). But Mayevski appears to have recently become a disciple of Krupp, from the diagram in NATURE, August 28, 1890 (p. 411), where the dotted line (1) represents roughly the resistance of the air to ogival-headed projectiles given in my "Final Report," 1880; line (2) represents the law of resistance deduced from these results by Major Ingalls, of the United States Artillery, which is similar to the law deduced by me (NATURE, April 29, 1886, p. 605); and line (3) represents the results Mayevski professes to have deduced from Krupp's Meppen experiments. My law of resistance has been very closely followed throughout by Mayevski, as is evident from the diagram above referred to, which is suggestive of a free use of the parallel ruler. The main object of these proceedings seems to have been to persuade the world, and the Americans especially, that Krupp guns are far superior to English guns, regard being had to the initial steadiness imparted by them to their projectiles. But this claim is unworthy of notice so far as it depends upon the Meppen experiments with chronoscopes, the patent defects of some of which were pointed out in NATURE, April 29, 1886 (p. 606). If, however, Government consider this matter worthy of investigation, there are simple practical methods of determining the comparative steadiness of projectiles fired from two or more guns.

At present, my concern is with English guns only, and I wish to point out, as briefly as possible, (1) that my results obtained from English guns are quite correct; (2) that the coefficients of resistance for each round are expressed by such a short unit of time that they are made to appear more irregular than they are in reality, while the variation in their value is just what experiment leads us to expect; and (3) that when my mean coefficients are fairly used to calculate results of good experiments made with recent English guns, in calm weather, the agreement between calculation and experiment is perfectly satisfactory.

My chronometric arrangements were made with a view to guard against the errors of remaining magnetism, which is the chief source of error in the measurement of extremely short intervals of time by the help of electro-magnetism. All the time-records were made by one electro-magnet, whose galvanic current was interrupted once a second by the swing of a half-second clock pendulum; and all the screen records were made by another electro-magnet, whose galvanic current was being rapidly interrupted by a self-acting contact-breaker, till the pull of the lanyard turned off the contact-breaker, and then fired the gun, after which the shot momentarily interrupted the galvanic current as it passed each of ten or more equi-distant screens. Also care was taken to reduce the strength of the galvanic currents, so as to leave each electro-magnet only just sufficient power for the performance of its appointed work. Under these circumstances it may be safely assumed that, if there were any errors arising from remaining magnetism, in either clock or screen records, they would be constant in each case, and therefore they would have no injurious effect on the result obtained. The records on a 4-inch cylinder were read off by a vernier to the 1/3000 of its circumference; but as the scale of time was in general only 9 or 10 inches to the second, it may be concluded that the records were read off to the 1/2000 of a second at least.

The accuracy of the time and of the screen records was tested by differencing, when slight adjustments were applied to render the first and second order of differences regular to an additional place of decimals. The following is a list of the adjustments so applied in seven successive rounds, 146-152, which are fair samples of those applied in the other rounds (1867-68). They are expressed in decimals of the unit read off by the vernier, or of the 1/2000 of a second. In round 258 an example is given of the correction of an occasional erroneous record at screen 6:—

Round	146.	147.	148.	149.	150.	151.	152.	258.
Screen 1	+0.3	+0.2	-0.2	0.0	+0.2	0.0	0.0	-0.1
2	-0.5	-0.1	+0.5	0.0	0.0	+0.2	+0.6	+0.1
3	-0.3	-0.2	-0.1	0.0	-0.7	-0.3	-0.1	+0.2
4	-0.1	-0.1	-1.0	0.0	+0.7	+0.4	-0.1	+0.6
5	+0.1	+0.2	-0.2	0.0	-1.4	+0.3	+0.7	-0.1
6	+0.3	-0.2	+0.3	0.0	+0.3	+0.5	+0.3	+32.9
7	-0.4	+1.6	+0.4	0.0	-0.2	0.0	-0.4	+0.6
8	-0.1	+0.7	-0.7	-1.0	-0.1	-0.1	+0.7	+0.2
9	+0.2	0.0	+0.1	0.0	+0.6	-0.4	-0.1	-0.1
10	-1.5	-0.4	-0.2	0.0	-0.1	-0.1	+0.2	-0.1

Here is conclusive evidence of the perfect trustworthiness of the observations made, such as no other ballistic experiments have afforded to my knowledge. When the readings of the screen records required only such slight adjustments as those above indicated, there could be no reasonable doubt about the perfect accuracy of the experiment, and the round was accordingly adopted as good in all cases, unless there was some known disturbing cause, as when the bronze gun expanded, or where the gas check left the shot, &c.

Although the records are read off only to the 1/2000 of a second, we are able to express the coefficients of resistance with much greater exactness through the employment of a long range (1350 feet) where the only absolute errors in time possible are at the two extremities of the range, and the accuracy of each of these readings is tested by the differencing. Supposing the retarding force of the air, acting upon an ogival-headed projectile moving in the direction of its axis with a velocity  $v$  f.s., to be expressed by  $-2bv^2$ , the values of  $2000bv/d^2$  corresponding to all velocities from 900 to 1700 f.s. were found by experiment in 1867-68, where  $w$  denotes the weight of the projectile in pounds, and  $d$  its diameter in inches. Corresponding to a velocity of 1200 f.s., the mean value of  $2000bv/d^2$  was found to be 0.0001089. But to avoid the use of so many decimal places,  $K$  was subsequently employed to denote  $(1000)^2 2bv/d^2 = (1000)^2 w \Delta^2 / d^2 t^2 = 108.9$ , where  $\Delta^2 t$  is the second difference of the times at which the shot passed successive equi-distant screens / feet apart, with a velocity 1200 f.s. more or less, and, in the case of the solid 5-inch shot it equals 0.000124. From this it appears that for the specified shot the time by which the unit of  $K$  is expressed is 0.0000112 in  $\Delta^2 t$ . Considering the shortness of this unit of time, it seems very natural that some variations should have been found in the experimental values of  $K$  for any specified velocity, derived as they have been from both *ballow* and *solid* projectiles fired with various charges from 3, 5, 7, and 9-inch guns. If we turn to actual experiment, it is plain that the coefficients of resistance for any given velocity cannot practically retain a constant value for all rounds. For do not we frequently read that shot are "noisy," or "unsteady" in their flight? There was much unsteadiness in the Jubilee rounds; and Captain May, R.N., in speaking of experiments with recent guns, remarked, "the range of 500 yards is selected, because at this range shell which start unsteadily will have steadied (that is if they ever do so), &c." It is, therefore, quite natural that exact experiment should afford evidence of this unsteadiness.

It now remains to test the value of my mean results by making use of them to calculate the ranges and times of flight of projectiles for comparison with the results of experiments made with recent guns. In 1879 some range tables of the 6.3-inch howitzer were forwarded to me to show that my coefficients for low velocities did not give satisfactory results. As the muzzle velocities in these tables were 332, 507, 628, 697, 740, and 751 f.s., and the elevations varied from 5° to 40°, the trajectories were much curved, so that my general tables were not applicable in these cases. But when the ranges and times of flight were properly calculated by Bernoulli's method, experiment and calculation were found to agree remarkably well. In the same way numerous German range tables (Krupp guns?) were calculated for muzzle velocities varying from 380 to 774 f.s., which gave very satisfactory results in general. Although there was no allowance for jump or vertical drift in these calculations for low muzzle velocities, the calculated often exceeded slightly the experimental ranges, showing that my resistances were perhaps a little too low. The results of each of these comparisons—32 English and 82 German—will be found in my "Final Report," 1880, pp. 45-47. For specimens of the best and worst results of each kind, see NATURE, April 29, 1886 (p. 606). Now Mayevski proposes to reduce these coefficients of resistance, already rather too low, by 20 per cent. more! (Ingalls, pp. 29, 36).

In consequence of the Krupp results, the authorities desired to have the accuracy of my results tested by practice on a long range, with a recent gun, and for this purpose they selected the 4-inch B.L. gun. Careful experiments were subsequently carried out with this gun (1887), which showed that my coefficients of resistance were perfectly satisfactory. But there was no real necessity for any special experiments to be made with this gun, as its own range table was afterwards found to be abundantly sufficient for the purpose of testing my results. By calculating trajectories carefully by Bernoulli's method, and then recalculating

lating by the general tables the time of flight over the range already obtained, and also the striking velocity, it is found that the general tables may be used for elevations of the 4-inch gun as high as 15°, or even more, with a muzzle velocity of 1900 f.s. In this way the mercè tyro may test my coefficients for his own satisfaction by calculating the times of flight over ranges of two or three miles given in any good range table for a high muzzle velocity. The following are the results of such testing, using the full extent of the range table of the 4-inch B. L. gun, chosen by the authorities. Muzzle velocity, 1900 f.s.; weight of ogival-headed shot (two diameters), 25 pounds:—

Range ... ..	2000.	3000.	4000.	5000.	6000.	7500 yds.
Horizontal muzzle vel.	1898 <sup>5</sup> / <sub>10</sub>	1895 <sup>0</sup> / <sub>10</sub>	1888 <sup>0</sup> / <sub>10</sub>	1875 <sup>0</sup> / <sub>10</sub>	1853 <sup>5</sup> / <sub>10</sub>	1796 <sup>8</sup> / <sub>10</sub> f.s.
Horizontal striking vel.	1124 <sup>9</sup> / <sub>10</sub>	955 <sup>4</sup> / <sub>10</sub>	843 <sup>4</sup> / <sub>10</sub>	751 <sup>2</sup> / <sub>10</sub>	667 <sup>6</sup> / <sub>10</sub>	556 <sup>5</sup> / <sub>10</sub> f.s.
Exp. time ... ..	4 <sup>21</sup> / <sub>10</sub>	7 <sup>30</sup> / <sub>10</sub>	10 <sup>49</sup> / <sub>10</sub>	14 <sup>3</sup> / <sub>10</sub>	18 <sup>4</sup> / <sub>10</sub>	26 <sup>2</sup> / <sub>10</sub>
Calc. time ... ..	4 <sup>17</sup> / <sub>10</sub>	7 <sup>10</sup> / <sub>10</sub>	10 <sup>48</sup> / <sub>10</sub>	14 <sup>30</sup> / <sub>10</sub>	18 <sup>66</sup> / <sub>10</sub>	26 <sup>43</sup> / <sub>10</sub>
Difference ... ..	-0 <sup>04</sup> / <sub>10</sub>	-0 <sup>10</sup> / <sub>10</sub>	-0 <sup>01</sup> / <sub>10</sub>	0 <sup>00</sup> / <sub>10</sub>	+0 <sup>26</sup> / <sub>10</sub>	+0 <sup>23</sup> / <sub>10</sub>

Here, as before, the calculated time is rather too short for velocities 1900 to 751 f.s. And if we allowed for a slight diminution of the density of the air for the higher elevations, as we ought to do, the calculated would throughout fall very slightly short of the experimental times of flight. Thus it is clear that my coefficients of resistance give perfectly satisfactory results when fairly tested by recent guns, chosen by Government, for velocities 330 to 751 f.s., and from 751 to 1900 f.s., or from 330 to 1900 f.s.

In the same way we may use the model range table, carefully prepared for the 12-inch B. L. gun by Captain May, R. N., for a muzzle velocity 1892 f.s., and weight of shot 714 pounds (Proc. R. A. Inst., 1886, p. 356):—

Range ... ..	1000.	2000.	3000.	4000 yards.
Experimental time ...	1 <sup>66</sup> / <sub>10</sub>	3 <sup>47</sup> / <sub>10</sub>	5 <sup>44</sup> / <sub>10</sub>	7 <sup>61</sup> / <sub>10</sub>
Calculated time ...	1 <sup>654</sup> / <sub>10</sub>	3 <sup>457</sup> / <sub>10</sub>	5 <sup>428</sup> / <sub>10</sub>	7 <sup>591</sup> / <sub>10</sub>
Difference ... ..	-0 <sup>006</sup> / <sub>10</sub>	-0 <sup>013</sup> / <sub>10</sub>	-0 <sup>012</sup> / <sub>10</sub>	-0 <sup>019</sup> / <sub>10</sub>

Here, again, the calculated times of flight, being a trifle too short, show that my coefficients of resistance are very slightly too low.

When coefficients tested in this manner give calculated times of flight accurately over ranges gradually increasing up to two or three miles, those coefficients must be correct for all practical purposes, and they will give correctly the striking velocity and time of flight for any other reasonable distance from the gun.

The tables of "Mayevski nach Siacci," printed by Krupp, 1883, may be used to calculate the times of flight of the shot fired from the 4-inch gun as above:—

Range ... ..	2000.	3000.	4000.	5000.	6000.	7500 yds.
Experimental time ...	4 <sup>21</sup> / <sub>10</sub>	7 <sup>20</sup> / <sub>10</sub>	10 <sup>49</sup> / <sub>10</sub>	14 <sup>3</sup> / <sub>10</sub>	18 <sup>4</sup> / <sub>10</sub>	26 <sup>2</sup> / <sub>10</sub>
Calculated time ...	4 <sup>10</sup> / <sub>10</sub>	6 <sup>91</sup> / <sub>10</sub>	10 <sup>11</sup> / <sub>10</sub>	13 <sup>69</sup> / <sub>10</sub>	17 <sup>97</sup> / <sub>10</sub>	24 <sup>58</sup> / <sub>10</sub>
Difference ... ..	-0 <sup>11</sup> / <sub>10</sub>	-0 <sup>29</sup> / <sub>10</sub>	-0 <sup>38</sup> / <sub>10</sub>	-0 <sup>61</sup> / <sub>10</sub>	-0 <sup>73</sup> / <sub>10</sub>	-1 <sup>62</sup> / <sub>10</sub>

From this it is evident that the reduction of my coefficients proposed by Mayevski on the strength of Krupp's experiments is uncalled for.

Again, it has been urged that my resistances ought to be reduced in order to adapt them to recent guns, which, it is assumed, impart an increased degree of steadiness to their projectiles. But that assumption requires proof. After most carefully testing the admirable range tables of the 4-inch and 12-inch B. L. guns, I have failed to find any indication whatever of increased steadiness in their projectiles. Besides, Admiral Robert A. E. Scott wrote to the *Morning Post* (November 9, 1889), condemning the system of rifling the 110-ton gun, which

he blamed for causing the projectiles to "issue from their guns with a very unsteady motion." He then went on to notice the large number of unsteady shot fired from the 9<sup>2</sup>-inch gun in 1888. I would also remind my critics that my coefficients of resistance for velocities 1000 to 1700 f.s. were derived from experiments made in 1867-68, while all those for velocities less than 1000 f.s., and greater than 1700 f.s., were derived from experiments in 1878-80, carried out with some of the newest and best guns of the time. As conclusive evidence of the excellence of the 3, 5, and 7-inch guns used in the early experiments, reference may be made to the fact that, from the results of the experiments of 1867-68, I was able to deduce the Newtonian law of resistance for velocities 1350 to 1700 f.s. (Proc. R. A. Inst., 1871); and using the mean of the eight numerical coefficients there given for velocities 1350, 1400, . . . 1700 f.s., the numerical value of  $k$  will be found to be 143<sup>9</sup>/<sub>10</sub>.

In 1879 experiments were made with a new Armstrong 6-inch B. L. gun, with velocities 1700 to 2250 f.s. (Reports, &c., Part ii., 48); and again, in 1880, further experiments were carried out with a new Armstrong 8-inch B. L. gun, with velocities 2250 to 2800 f.s. (Final Report, 56). Combining these three sets of experiments, Major Ingalls found that the Newtonian law of resistance held good for velocities 1330 to 2800 f.s., where  $k = 142<sup>1</sup>/<sub>10</sub>$  (Ext. Bal., 30). I also deduced the same law for velocities 1300 to 2800 f.s., where  $k = 141<sup>5</sup>/<sub>10</sub>$  (NATURE, 1886, p. 606). And lastly, after a thorough revision of the reduction of every round, I finally adopted the same law for velocities above 1300 f.s., where  $k = 141<sup>2</sup>/<sub>10</sub>$ .

Hence it appears that the early experiments of 1867-68 were so accurate that they gave a correct law of resistance for velocities 1350 to 1700 f.s., which has since been found to hold good for velocities 1300 to 2800 f.s.; and they also gave the coefficient  $k = 143<sup>9</sup>/<sub>10</sub>$  (with *studded* shot) sufficiently accurate for all practical purposes up to a velocity 2800 f.s. This is conclusive evidence of the steadiness of the shot in the early experiments, and of the accuracy of the method of reduction of those experiments.

But when those coefficients, which have been found correct by the use of the general tables, are employed to calculate trajectories of elongated shot moving with high velocities, the calculated ranges and times of flight gradually fall more and more below those quantities given in the range tables, as the elevation increases beyond 4° or 5°. These defects are generally only small when the variation in the density of the air is taken into account; but their presence indicates some slight disturbing cause independent of the coefficients of resistance. We can now make use of the exact method of calculating trajectories given by modern analysis, which was first published by J. Bernoulli. But this method applies with strictness only to the motion of a spherical projectile, whose centre of gravity coincides with its centre of figure. Many years ago Count St. Robert remarked: "On doit en conclure que les formules ordinaires de la balistique ne peuvent représenter la trajectoire décrite par les projectiles *allongés*" (Balistique, p. 183). Also Mayevski has published an elaborate paper, "De l'Influence du Mouvement de Rotation sur la Trajectoire des Projectiles oblongs dans l'Air" (Technologie Mil., 1866, pp. 1-150), which, however, leads to no useful result beyond showing that the author recognized the effect of drift on the form of the trajectory. The chief cause of the difficulty is this. For a short time after a steady elongated shot has left a rifled gun, the shot preserves the parallelism of its axis, and in consequence of the action of gravity the point of the shot gradually rises above its trajectory till the resistance of the air causes the axis of the shot to begin to describe a conical surface, with nearly constant vertical angle, about the moving tangent to the trajectory. Consequently, soon after a steady elongated shot leaves the muzzle of a rifled gun, the resistance of the air acting on the inclined under side of the shot, begins to raise the shot bodily, and continues to do so until its axis has made one-fourth of a revolution about the tangent to the trajectory. This vertical drift, near the gun, causes the shot to move in its path as if it had been fired at a slightly increased elevation. Consequently, the observed range and time of flight are each somewhat greater than that due to the elevation at which the gun was laid.

Another difficulty, common, however, to both spherical and elongated shot, is caused by the jump of the gun. In the range tables of the 4 and 12-inch guns above considered, six minutes were allowed for the effect of jump for all elevations. But Major Ingalls remarks that "it varies in value from an angle

too small to be appreciable, to one of a degree of arc or even more. . . . It also varies somewhat with the angle of elevation." In one of his examples he supposed the jump to be 22 to 23 minutes. Although the jump and vertical drift are uncertain in amount, they have considerable influence on the range and time of flight, and on this account the calculation of trajectories is a decidedly unsatisfactory method of testing the coefficients of resistance of the air to elongated projectiles.

In the early days of elongated projectiles the vertical drift caused by the "kite-like action" of the shot was duly recognized, but of late this disturbing force has been commonly ignored. For now, when a calculated range is shorter than the experimental range, it is at once assumed that the theoretical resistance is too high. This resistance is forthwith reduced so as to make the calculated agree with the experimental ranges, but seldom is any care taken to compare the time of flight calculated with this reduced resistance with the experimental time. It ought, however, to be remembered that, while a reduction of resistance increases the range it diminishes the time of flight over a given range. Major Ingalls has given a complete example of this method of correcting my resistance (Problems, &c., p. 151). For elevations of

2°, 4°, 6°, 8°, and 10°,

he found it necessary to reduce my coefficients by

4'5      2'3      5'2      8'1      9.7 per cent.,

in order to obtain the experimental ranges by calculation; and these reduced resistances gave the calculated times of flight too short by

0''09      0''12      0''13      0''26 and 0''42,

which proves clearly that the theoretical resistances had been too much reduced throughout. Also, if the method of correction pursued in the above example was correct, it would follow that the coefficient of resistance is a function of the elevation, which is simply absurd.

On the other hand, suppose we correct the elevation so as to make the calculated agree with the experimental range, which seems to me to be a satisfactory *approximate* correction in such cases. A careful calculation of the trajectory of an ogival-headed shot (two diameters) fired from the 4-inch B.L. gun, at an elevation of 15°, gave a range of 6448 yards (185 yards too short by the range table), and time of flight 20''46 (1''10 too short), the density of the air having been supposed to vary with the height of the shot. Now, corresponding to an elevation of 14°16', the range table gives a range of 6448 yards, and time of flight 20''53. If we suppose that the elevation of the gun, 14°16', was practically increased by 44' by jump and vertical drift, we obtain an elevation of 15° for the initial direction of the shot. But, according to calculation, for an elevation of 15° we have found the range 6448 yards exactly, and the time of flight 20''46, which is only -0''07 in error, and the calculated horizontal striking velocity is 646 f.s. This, I maintain, is the proper method of correction, because it corrects both *range* and *time* of flight, when there is no wind. Using the general tables and the horizontal muzzle velocity, the calculated time over 6448 yards is found to be 20''53, and horizontal striking velocity 647 f.s., where  $\tau = 0.967$ , the mean density of the air, as the projectile would rise to a height of 1800 feet.

If the above be a correct view of what takes place, it follows that the axis of the shot during its flight is inclined at such a small angle to the direction of its motion, that the resistance of the air to its forward motion is not sensibly greater than when it moves in the direction of its axis. But small as this angle must be, we find evidence of the marked effect of the lateral action of the air in causing the shot to drift to the right towards the end of the range. It is therefore to be expected that the resistance of the air, acting from below on the shot, soon after it leaves the gun will raise the shot upwards, and cause it to move as if it had been fired at an elevation a little greater than that at which the gun was laid.

The Ordnance Committee fired some ogival-headed projectiles from a 9.2-inch wire gun at high elevations in 1888, professing to try whether calculations of trajectories at very long ranges are trustworthy. But before experimenting they invited calculators to furnish them with the calculated range and time of flight of a 380-pound elongated shot fired at an elevation of 40° with a muzzle velocity of 2360 f.s. My calculations for an ogival head, struck with a radius of one diameter and a half, gave a range of 19,436 yards, and time of flight 62''15, which were sent in in

March 1888. Allowing 300 yards for jump and vertical drift, I obtained a range of 19,736 yards. In April two rounds were fired with a velocity of 2375 f.s. at an elevation of 40°, which gave ranges of 21,048 and 21,358 yards. My reply to this announcement, by return of post, was that the ranges were about 1500 yards too great. In July the experiment was repeated, which gave ranges of 20,236 and 20,210 yards, being a reduction of near 1000 yards. Two rounds fired at an elevation of 30° gave ranges of 17,500 and 18,344 yards; two at 35° gave ranges of 19,420 and 18,963 yards; and one at 45° gave a range of 21,800 yards. The times of flight have not been published. These great variations in range were due in part to unsteadiness in the motion of the shot, but chiefly to the prevalence of high favourable winds.

In order to test guns or coefficients of resistance in a satisfactory manner, *calm weather* is absolutely necessary. And if the shot is expected to rise to a height of two or three miles, trial balloons ought to be sent up to test the state of the currents in the higher regions. Afterwards, when good mean results of experiments have been obtained, then, and not till then, may these mean results be used to test the results of calculation. Experiments ought not to be made at all unless precautions necessary to secure a correct result can be taken.

I have calculated a complete range table for the 9.2-inch gun for elevations 1° to 45°, according to the original programme of the Ordnance Committee (NATURE, September 13, 1888, p. 468), where the net results of calculation have been given. These ranges will require an addition perhaps of about 2 per cent. for jump, vertical drift, &c., and a further 1 per cent. if the ogival head be struck with a radius of two diameters instead of one and a half, and the increment of time must be ruled by this increment of range.

My sole object having been to obtain the correct law of resistance of the air to the motion of projectiles, I was always ready to consider any proposed correction. But my results, obtained from numerous and most exact experiments, could be changed only on perfectly satisfactory evidence. That evidence I have failed to obtain in any single case, so that my results remain practically the same as they were given in my original reports, 1868-80. I have recently published a revised account of all my experiments, accompanied by newly calculated general tables, for both English and French measures, and other tables required in the calculation of trajectories, according to the results of modern analysis. With these helps I have now thoroughly tested my final results by the use of range tables of the 4-inch, 6.3-inch, and 12-inch guns, with the most gratifying results. And Major McClintock, R.A., has tested my coefficients for small-arm bullets, with very satisfactory results (Proc. R.A. Inst., xii. 569). This evidence of the accuracy of my results is the more valuable because it is derived from Government experiments, made for other purposes, which have manifestly been carried out with great care and ability. Anyone so disposed has the means to re-examine the whole matter for himself. If there be not some error in my calculations, it appears that my results do not admit of any real improvement, and consequently my labours in this matter may be considered to have reached a satisfactory conclusion.

F. BASHFORTH.

#### FORTHCOMING SCIENTIFIC BOOKS.

THE following is a list of scientific works which will be issued by various publishers in the course of the spring:—Messrs. Macmillan and Co.:—"Essays on some Controverted Questions," with a Prologue, by Prof. Huxley; "The Beauties of Nature," by Sir John Lubbock, F.R.S., illustrated; "Island Life; or, The Phenomena and Causes of Insular Faunas and Floras," including a revision and attempted solution of the problem of geological climates, by A. R. Wallace, with illustrations and maps, new and cheaper edition; "The Apodide," a morphological study, by Henry M. Bernard, illustrated (Nature Series); "Experimental Evolution," by Henry de Varigny; "The Diseases of Modern Life," by B. W. Richardson, F.R.S., new and cheaper edition; "The Geography of the British Colonies"—"Canada," by George M. Dawson, "Australia and New Zealand," by Alexander Sutherland (Macmillan's Geographical Series); "Scientific Papers," by Oliver Heaviside; "The Algebra of Co-Planar Vectors and Trigonometry," by R. B. Hayward, F.R.S., Assistant Master at Harrow; "Key and Students'

Companion to Higher Arithmetic and Elementary Mensuration," by P. Goyen, Inspector of Schools, Dunedin, New Zealand; "Arithmetic for Schools," by Bernard Smith, late Fellow and Bursar of St. Peter's College, Cambridge; carefully revised in accordance with modern methods by W. H. H. Hudson, Professor of Mathematics, King's College, London; "Blowpipe Analysis," by J. Landauer, authorized English edition by J. Taylor and W. E. Kay, of the Owens College, Manchester, new edition, thoroughly revised with the assistance of Prof. Landauer; "Nature's Story Books," I. "Sunshine," by Amy Johnson, illustrated.

The Clarendon Press:—"Mathematical Papers of the late Henry J. S. Smith, Savilian Professor of Geometry in the University of Oxford," with portrait and memoir, two vols.; "Plane Trigonometry without Imaginaries," by R. C. J. Nixon; "A Treatise on Electricity and Magnetism," by J. Clerk Maxwell, new edition; "A Manual of Crystallography," by M. H. N. Story-Maskelyne; "Elementary Mechanics," by A. L. Selby; "Weismann's Lectures on Heredity," Vol. II., edited by E. B. Poulton, F.R.S.; "Epidemic Influenza," by F. A. Dixey.

The Cambridge University Press:—"A Treatise on the Mathematical Theory of Electricity," by A. E. H. Love, Fellow of St. John's College, Cambridge, two vols., Vol. I. in the press; "The Origin of Metallic Currency and Weight Standards," by W. Ridgeway, Professor of Greek, Queen's College, Cork, and late Fellow of Gonville and Caius College; "Solutions of the Examples in 'A Treatise on Elementary Dynamics,'" by S. L. Loney, formerly Fellow of Sidney Sussex College, Cambridge.

Messrs. Longmans and Co.:—"Darwin and after Darwin: an Exposition of the Darwinian Theory, and a Discussion of Post-Darwinian Questions," by George John Romanes, F.R.S., two vols.

Messrs. A. and C. Black:—"Life in Motion; or, Muscle and Nerve," a series of lectures delivered at the Royal Institution, Christmas, 1891, by John Gray McKendrick, F.R.S., illustrated.

Messrs. J. and A. Churchill:—"A Treatise on Hygiene, edited by Thomas Stephenson and Shirley F. Murphy, in two vols., with numerous illustrations, Vol. I. nearly ready; "Chemical Technology; or, Chemistry in its Applications to Arts and Manufactures," edited by Charles E. Groves, F.R.S., and William Thorp (with which is incorporated "Richardson and Watts' Chemical Technology"), Vol. II. "Lighting; Fats and Oils, Candles, Stearine, Gas, Electric Lighting"; "Materia Medica, Pharmacy, Pharmacology, and Therapeutics," by W. Hale White; "The Student's Guide to Diseases of the Nervous System," by J. A. Ormerod, with 66 illustrations; "A Dictionary of Psychological Medicine, giving the Definition, Etymology, and Synonyms of the Terms used in Medical Psychology, with the Symptoms, Pathology, and Treatment of the Recognized Forms of Mental Disorder, together with the Law of Lunacy in Great Britain and Ireland," in two vols., edited by D. Hack Tuke.

Messrs. Whittaker and Co.:—"New volumes of the Specialists' Series—"Lightning Conductors and Guards," by Oliver J. Lodge, F.R.S., with numerous illustrations; "The Dynamo," by C. C. Hawkins and F. Wallis, with numerous original diagrams; "A Guide to Electric Lighting," by S. R. Bottono, for householders and amateurs, with 77 illustrations. Whittaker's Manual Instruction Series—"Manual Instruction: Woodwork," by S. Barter, Organizer and Instructor for the London School Board, and to the Joint Committee on Manual Training of the School Board for London, the City and Guilds of London Institute, and the Worshipful Company of Drapers, with over 300 illustrations; "Leather Work, Stamped, Moulded, and Cut, Cuir-Bouilli, Sewn, &c.," by Charles G. Leland, author of "Wood Carving," with numerous illustrations. Whittaker's Library of Popular Science—"Mineralogy," by Dr. F. Hatch, with numerous illustrations; "Chemistry," by T. Bolas, with many illustrations.

Messrs. Sampson Low and Co.:—"Answers to the Questions on Elementary Chemistry, Theoretical and Practical (Ordinary Course), set at the Examinations of the Science and Art Department, South Kensington, 1887 to 1891," by John Mills, two vols., fully illustrated; "Chemistry for Students, consisting of a Series of Lessons based on the Syllabus of the Science and Art Department, and specially designed to facilitate the experimental teaching of Elementary Chemistry in Schools and Evening

Classes," by John Mills, numerous illustrations; "Decorative Electricity," by Mrs. J. E. H. Gordon, with a chapter on Fire Risks by J. E. H. Gordon, and numerous illustrations by Herbert Fell, engraved on wood by J. D. Cooper; "Examination of Soils," by W. T. Brannt.

Messrs. George Philip and Son:—"Makers of Modern Thought; or, Five Hundred Years' Struggle (A.D. 1200 to A.D. 1699) between Science, Ignorance, and Superstition," by David Nasmyth, in two volumes; "Christopher Columbus," by Clements R. Markham, Vol. VII. of "The World's Great Explorers and Explorations"; "The Development of Africa," by Arthur Silva White, new and cheap edition, revised to date, with fourteen coloured maps; "Phillips' General Atlas," entirely new and revised edition, with several additional maps; "Phillips' Systematic Atlas," for higher schools and general use, a series of physical and political maps of all the countries of the world, with diagrams and illustrations of astronomy and physical geography, specially drawn by E. G. Ravenstein; "Phillips' Atlas of Astronomy," a series of seventy-two plates, with notes and index by Sir Robert Stawell Ball, F.R.S., Royal Astronomer of Ireland; "Tourists' Handy Volume Atlas of Europe," a series of coloured maps, with notes, plans of cities, and complete consulting index, by J. G. Bartholomew.

Messrs. Swan Sonnenschein and Co.:—"Animal Colouration," by Frank Beddard, Protector to the Zoological Society, with four coloured plates by P. J. Smit, and numerous woodcuts; "Text-book of Embryology: Man and Mammals," by Dr. Oscar Hertwig, of the University of Berlin, translated and edited from the third German edition by Dr. E. L. Mark, Professor of Anatomy in Harvard University, fully illustrated; "Text-book of Embryology: Invertebrates," by Drs. Korschelt and Heider, of the University of Berlin, translated and edited by Dr. E. L. Mark, Professor of Anatomy in Harvard University, and Dr. W. M. Woodworth, Assistant Professor in Harvard University, fully illustrated; "Text-book of Geology," adapted from the work of Dr. Kayser, Professor in the University of Marburg, by Philip Lake, of St. John's College, Cambridge, fully illustrated; "The Geographical Distribution of Disease in England and Wales," by Alfred Haviland, with several coloured maps; "A Treatise on Public Hygiene and its Applications in different European Countries," by Dr. Albert Palmger, translated, and the English portion edited and revised, by Arthur Newsholme, fully illustrated; "The Photographer's Pocket-book," by Dr. E. Vogel. "Introductory Science Text-Books," additions—introductions to the study of "Zoology," by B. Lindsay, illustrated; "The Amphioxus," by Dr. B. Hatschek, of the University of Vienna, and James Tuckey, of the University of Durham, illustrated; "Geology," by Edward B. Aveling, Fellow of University College, London, illustrated; "Physiological Psychology," by Dr. Th. Ziehen, of the University of Jena, adapted by Dr. Otto Beyer, with twenty-two figures.

Messrs. Crosby Lockwood and Son:—"A Hand-book of Brewing, a Practical Treatise for the use of Brewers and their Pupils," by Herbert Edwards Wright; "A Treatise on Earthy and other Minerals and Mining," by the late D. C. Davies, third edition, revised and very considerably extended by his son, E. H. Davies; "Fuels: Solid, Liquid, and Gaseous, their Analysis and Valuation," for the use of chemists and engineers, by H. J. Phillips, second edition, revised and much enlarged.

#### SCIENTIFIC SERIALS.

THE most important article in the numbers of the *Journal of Botany* for January and February is one by the late Dr. A. Barclay on rust and mildews in India. He shows that the years in which the grain-crops were deficient have been those in which the climatal conditions were favourable to the growth of parasitic fungi. The chief enemy to wheat in India is *Puccinia rubigo-vera*; and it is an interesting fact that while the acidiflorous in this Uredine occurs in Europe on Borraginaceous plants, no acidium is known in India on any species of the order. Dr. Barclay believes that its life-history has a different course in India from that taken in Europe.—Mr. W. G. Smith reports the progress at present made in the commission which he has received from the Trustees of the British Museum to make a series of water-colour drawings of the whole of the British *Basidiomycetes* for the public gallery of the Department of Botany.—A series of papers is commenced in these numbers on the first records of British flowering plants, by Mr. W. A. Clarke.

THE *Bulletino* of the Italian Botanical Society is now published apart from the *Nuovo Giornale*. The first number contains reports of the papers read at the annual meeting, held at Naples in August, and of the regular meetings held since till the end of the year, and of the discussions which followed. Among the more noteworthy papers may be mentioned the following:—On a new carpellary theory, by Signor F. Pasquale, who maintains that the carpel is not derived, as has been generally supposed, from the modification of a single leaf, but from the concrescence of two, or sometimes of three leaves, which unite in the formation and nutrition of the ovules and seeds.—On the floral structure and process of pollination in some species of *Nigella*, by Dr. A. Terracciano.—On the period of formation of the inflorescence within the bud of the vine, by Signor U. Martelli.—On the non-sexual propagation of *Cynomorium coccineum*, by the same writer, who has established its parasitism on *Atriplex nummularia*.—Prof. G. Arcangeli also describes the results of experiments on the cultivation of this plant, which he finds to be parasitic on many hosts.—On earthquakes and vegetation, by Signor A. Goiran. He finds the effects of seismic motions in the earth to be the more rapid germination of seeds, as well as a more rapid growth of the young plant.—Signor E. Tanfani has a paper on the teaching of botany in gymnasia, which he considers to be in a very backward state in Italy.

THE *Botanical Gazette* for January contains two interesting original papers:—Herr A. F. Foerste speaks of the relationship of autumn- to spring-blossoming plants, and concludes that late autumn-flowering plants may be divided into two classes—those which have developed from summer-flowering plants by the increase in the number of internodes with their appendages and the gradual retardation of growth, and those which have developed from spring-blossoming plants by the premature development of buds destined to flower during the ensuing spring.—Mr. H. L. Russell discourses on the effect of mechanical movement on the growth of certain plants. The experiments were made chiefly on certain yeast-fungi; and the general results were that the development of filaments was hindered by shaking; but that strong agitation greatly increases the activity of cell-division, while it diminishes the intensity of fermentation. This may be compared with the fact mentioned above relative to the effect of earthquakes on the growth of plants.

THE greater part of the number of the *Nuovo Giornale Botanico Italiano* for January is occupied by a paper by Signor A. Jatta, on the Lichens of Italy, accompanied by a very elaborate bibliography.—Signor C. Massolongo has a note on a floral monstrosity in *Jasminum grandiflorum*; and Dr. R. Cobelli a paper on the movements of the flower and fruit of *Erodium gruinum*. These movements belong to three organs—the calyx, the upper portion of the style, and the mericarp—and do not appear to be in any way connected with the pollination of the flower, since the species is apparently self-fertilized, and no pollinating insects were observed at any time upon it.

## SOCIETIES AND ACADEMIES.

### LONDON.

Physical Society, February 26.—Prof. W. E. Ayrton, F.R.S., Past President, in the chair.—Prof. S. P. Thompson, F.R.S., read a paper on modes of representing electromotive forces and currents in diagrams. The author said he had found it advantageous in some cases to depart from the usual methods of representation, and he now brought the subject before the Society in order to have it discussed and improvements suggested. To indicate the directions of currents in wires seen end-on, Mr. Swinburne had used circles with and without crosses, but no symbol had been suggested for wires not conveying currents. He (Prof. Thompson) thought the plain circle should be used for inactive wires. A circle with a dot in the middle could then be used to indicate that a current was flowing towards the observer, and a circle with a cross in it to represent a wire conveying a current away. These meanings could be recalled by considering the direction indicated by an arrow, the dot showing the tip of the arrow, and the cross the feathers. Some method of distinguishing between E.M.F. and current was required. For this he proposed to use thin-stemmed arrows with feathers for E.M.F.'s, and thick-stemmed ones without tails for currents. In the case of electrical transmission of energy, this convention had the important advantage that

where the two arrows had the same direction, energy was being given to the system, and where the arrows were opposite, energy was leaving it. Mr. Maycock, he said, had recently published a simple rule for finding the direction of magnetic force due to a current of known direction in a wire. Grasp the wire with the right hand, the thumb pointing in the direction of the current; the fingers will then encircle the wire in the direction of the magnetic force. Dr. Fleming's well-known rule for induced currents was also a *right-hand* rule, but as it referred to the direction of *currents*, another rule was necessary when considering motors. By making the rule refer to E.M.F.'s, only one rule was required for generators and motors. For alternating currents the author found it convenient to draw polar curves analogous to Zeuner's valve diagrams. Suppose a line  $OP$  (Fig. 1), representing the maximum value of an E.M.F. or

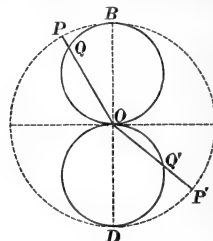

FIG. 1.

current whose magnitude is a sine function of the time, to revolve at uniform velocity about  $O$ ; the intercepts  $OQ$ ,  $OQ'$ , &c., cut off by circles  $OQB$ ,  $OQ'D$ , will represent the magnitudes at the times corresponding to the positions  $OP$  and  $OP'$ . The effect of lag can also be represented in such diagrams. In cases where the variables are not sine functions, the curves  $OQB$  and  $OQ'D$  are no longer circles. Polar diagrams representing the E.M.F. and current curves obtained by Prof. Ryan in his transformer experiments were exhibited, and a working diagram, illustrating the changes in three-phase currents, was shown. To show the directions of induced E.M.F.'s in diagrams of dynamos and motors, diagonal shading of the pole-faces was sometimes convenient; the lines over north poles being drawn from left to right downwards in the direction of the middle stroke of the letter N, and those over south poles from left to right upwards. A conductor passing over a north pole from left to right would have an E.M.F. induced in a downward direction, as indicated by the slope of the diagonal lines. This method of representation was used to show the ways of connecting up multipolar drum armatures, the winding being supposed cut along a generating line, unwrapped from the core, and laid out flat in the manner adopted by Fritsche. In connection with armatures, the author said a formula had been published by means of which the nature of a winding consisting of a given number of convolutions, and to be used with a given number of poles, could be predetermined. This, he thought, would be very useful in practice. Mr. Blakesley said the old method of representing alternate current magnitudes by means of the projections of revolving lines, seemed preferable, for it left no ambiguity as to the directions of the quantities. The method of shading the poles also required that the direction in which the diagram was to be viewed should be known before the direction of the E.M.F. could be determined. Mr. Swinburne suggested that the author might use a bow to represent E.M.F., and an arrow for current. He was glad to see that Prof. Thompson recognized the differences in dynamos and motors, and approved of the view that mnemonic rules should refer to E.M.F. and not to current. The diagrams of drum windings would be very useful, and he hoped the author would make the subject clear to ordinary workmen in the next edition of "Dynamo-Electric Machinery." Prof. Perry considered it undesirable to use polar curves for anything but circles. In his opinion it was not sufficiently known that any curve can be split up into a series of sine curves, and each component dealt with separately; the separate results being added together in the end. Mr. Swinburne pointed out that before one could analyze a curve in this way, the curve must be known, and would probably have to be determined ex-



perimentally. If means for finding one curve are available, any other required curve could probably be found by the same apparatus; hence there was no need for analysis. Prof. Perry remarked that experiments could not be made on a machine before the machine was built; whereas the E.M.F. curve could be predetermined from its design. By analysis, its current curves, when working under various conditions, could be found. Prof. Ayrton, referring to the mnemonic character of the modes of representation described by Dr. Thompson, suggested that the symbols in the author's book should be more mnemonic. He himself was in the habit of using large letters for currents and small ones for resistances: A and a for the armature, S and s for series, and Z and z for the shunt, currents and resistances, respectively, and  $\sigma$  and  $\zeta$  for the series and shunt turns. He also found the following "electromotive force" rule very convenient. Draw three rectangular axes, OM, OF, and OE, as shown in Fig. 2. If, then, OF represents the direction of the

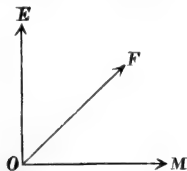

FIG. 2.

force (magnetic), OM that of the motion, then OE shows the direction of the induced E.M.F. Dr. Thompson, in replying, said he thought Mr. Blakesley had misunderstood what had been said, for no ambiguity existed. In describing the windings of armatures, difficulty arose from want of proper names for the various elements, and in his forthcoming work suitable names had been given. To Prof. Ayrton he pointed out that in his book he (Dr. Thompson) had used mnemonic characters, for  $r_m$ ,  $r_s$ , and  $r_{sh}$  represented the resistances of armature, shunt, and series magnet coils respectively. The symbol I for current had also been recommended for adoption by the Frankfort Committee. He objected to Greek letters except for specific quantities, such as angles, specific inductive capacities, refractive indices, &c. He appreciated the simplicity of Prof. Ayrton's E.M.F. rule, but thought it would be better to rotate OE and OF through a right angle about OM, thus giving Fig. 3.—A paper on

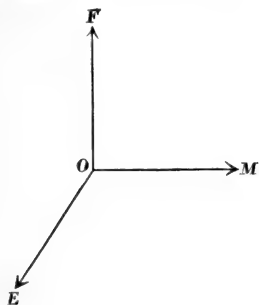

FIG. 3.

the flexure of long pillars under their own weight, by Prof. M. Fitzgerald, was read by Mr. Blakesley. The subject of upright pillars fixed at the base and free at the top is treated mathematically, the differential equation being integrated in two series, involving ascending powers of the variable. Putting L for the ratio of length to diameter, the results, when applied to thin steel tubes and rods, for which Young's modulus is taken as 12,000 tons per square inch, show that the limiting height (in feet) of pillars which can stand without bending is given by  $H = \frac{15 \times 10^6}{L^3}$  for tubes; and  $H = \frac{7.5 \times 10^6}{L^2}$  for rods. If L = 100, the maximum height of a tube is 1500 feet, the diameter being 15 feet. For wires, L may have larger values,

and the limiting length of a No. 28 B.W.A. steel wire, is about 10 feet. In the case of pillars whose neutral axes are constrained to be vertical both at top and bottom, the results show that a definite ratio must exist between the bending moments producing the constraints.—A paper on choking coils, by Prof. Perry, F.R.S., and a description of the uses of Rice's choking coils for regulating the brilliancy of incandescent lamps, by Mr. Hammer, were postponed until next meeting.

**Linnean Society, March 3.**—Prof. Stewart, President, in the chair.—A letter was read from the Home Secretary, conveying the thanks of Her Majesty the Queen for the address of condolence which had been forwarded on behalf of the Society on the death of H. R. H. the Duke of Clarence and Avondale.—The President announced the presentation by Sir Joseph Hooker to the Society of two medallion portraits of Sir James Ross and Dr. John Richardson, whose names are well known in connection with Arctic exploration. The medallions were executed in 1843 by the late Bernhard Smith. A vote of thanks to the donor was passed unanimously.—Mr. Clement Reid exhibited a collection of fossil plants and seeds which he had found associated with the bones of Rhinoceros and other mammals in the neighbourhood of Selsea, and West Wittering. By means of diagrams Mr. Reid showed the exact position of the bed, and described the condition in which the various specimens were deposited.—On behalf of Mr. W. E. Beckwith, of Shrewsbury, Mr. H. Seebohm exhibited a specimen of White's Thrush (*Turdus varius*) which had been shot near Shrewsbury on January 14 last. He pointed out that this species, which inhabits Eastern Asia, belongs to the sub-genus *Oreocincla*, an exclusively Eastern group of ground Thrushes, and is the only one which is Palearctic and migratory. It does not breed anywhere west of the Yenisei, and its occurrence in Europe is accidental. Mr. Seebohm added that it had been met with twice in France, four times in Italy, three times in Belgium, once or twice in Austria and Prussia, once in Norway, thirteen times in Heligoland (between 1827 and 1884), and about a score of times in the British Islands, including three occurrences in Ireland, and one in the extreme south of Scotland.—On behalf of Mr. A. Craig Christie, the Secretary exhibited some specimens, as was supposed, of *Lycopodium complanatum*, collected in Scotland, on which it was suggested that the plant might be regarded as British. In the opinion, however, of Mr. James Groves, who had carefully examined the specimens, and other botanists present, they were referable to *L. alpinum*. Mr. Groves pointed out the distinctive characters of both. Mr. Carruthers was of opinion that *L. complanatum* had been met with in the south of England, but not within the last ten years. Mr. E. M. Holmes was under the impression he had seen it growing a few years ago near Stroud.—A paper was then read by Mr. A. D. Michael, on variations in the internal anatomy, and especially the genital organs, of the *Gamasine*, a typical sub-family of the Acari. In this paper the author gave the results of two years' research, including many hundreds of dissections and serial sections, with lengthy observations of the living creatures. The comparison of variable organs was worked out in numerous species, showing great specific differences. Four of the species were found to be previously undescribed, and for these the names *Hæmogamasus horridus*, *H. nidi*, *Lalaps oribatoides*, and *L. lignoniformis* were proposed.

**Royal Microscopical Society, February 17.**—Dr. R. Braithwaite, President, in the chair.—Prof. F. Jeffrey Bell said that he had, in accordance with the resolution passed at the last meeting, forwarded a copy of the message of condolence from the Society to the Prince of Wales, to General Sir Dighton Probyn, and he had received the following letter of acknowledgment:—"Sandringham, Norfolk.—General Sir Dighton Probyn, Comptroller and Treasurer of the Household, is desired to convey to the members of the 'Royal Microscopical Society' the heartfelt thanks of the Prince and Princess of Wales for the Society's kind resolution, expressing sympathy for their Royal Highnesses in their deep affliction.—January 25, 1891."—Mr. Watson exhibited and described a new vertical camera for photomicrography designed upon the same lines as that used by Dr. Van Heurck.—The President then read his annual address, postponed from the last meeting under the special circumstances then mentioned. The subject chosen was the impregnation and modes of reproduction in Ferns and Mosses; diagrams in illustration were exhibited and explained, and specimens were also shown under microscopes.—A cordial

vote of thanks, proposed by the Rev. Canon Carr and seconded by Prof. Groves, was given to the President for his valuable address.—Mr. J. J. Vezey moved that the best thanks of the Society be given to its officers, and also to the auditors and scrutineers for their services during the year.—The President declared the motion to be carried by acclamation.—Prof. Bell thanked the Society on behalf of himself and the other officers, at the same time calling attention to the special services rendered by the Treasurer, Mr. Frank Crisp.—The following are the names of the members of the new Council, who met for the first time at this meeting:—President: Dr. R. Braithwaite. Vice-Presidents: Mr. A. W. Bennett, Prof. J. W. Groves, Mr. G. C. Karop, and Mr. A. D. Michael. Treasurer: Mr. Frank Crisp. Secretaries: Prof. F. Jeffrey Bell and the Rev. Dr. W. H. Dallinger. Ordinary members: Dr. Lionel S. Beale, Rev. E. Carr, Mr. James Glaisher, Dr. R. G. Hebb, Mr. E. M. Nelson, Mr. T. H. Powell, Prof. Urban Fritchard, Mr. W. W. Reeves, Prof. C. Stewart, Mr. W. T. Suffolk, Mr. C. Tyler, and Mr. F. H. Ward.

## PARIS.

**Academy of Sciences, March 7.**—M. d'Abbadie in the chair.—Fermentation of blood, by MM. Berthelot and G. André. The blood of cattle, defibrinated, was fermented for 130 days in a water-bath at 35°. The paper contains an account of the products of the fermentation. It will be published in greater detail in the *Annales de Chimie et de Physique*.—On the distribution in latitude of solar phenomena observed at the Royal Observatory of the Roman College during the second half of 1891, by M. P. Tacchini. (See Our Astronomical Column.)—Phenomena observed at Kaloca, on the large group of spots of February 1892, by M. J. Fényi. A prominence, 124" high, was observed in the position 220°–230°, as the recent large spot-group was crossing the limb.—On the impossibility of certain movements, by MM. A. de Saint-Germain and L. Lecornu.—On the movement of a conical pendulum, by M. de Sparre.—On electro-capillary phenomena, by M. Alphonse Berget.—On the co-existence of dielectric power and electrolytic conductivity, by M. E. Bouty. It appears from the experiments described that the dielectric constant only varies slightly under conditions which produce an enormous increase of conductivity. Thus, water and ice have sensibly the same dielectric constant, whilst the conductivity may vary from 1 to 10<sup>5</sup> or 10<sup>6</sup>.—On the thermal conductivity of crystalline bodies, by M. Charles Soret.—Rule for finding the number and nature of accidentals of the gamut in a tone and a given mode, by M. Pierre Lefebvre.—On the density of aqueous solutions, by M. Georges Charpy. The author concludes from his results that the variation of the density of a solution, as a function of the concentration, is a complex phenomenon, and cannot be used in studying the state of the dissolved body. There is no reason why the solution at which the maximum density is reached should be regarded as corresponding to a definite hydrate.—Compounds of gaseous ammonia with boron iodide and bromide, by M. A. Besson.—Synthesis of the minerals crocoisite and phenicite (*phoricochroïte*), by M. C. Luedeking.—On the value of the primary alcoholic function, by M. de Forcrand.—On the production of quinine di-iodomethoxide from capryne, by MM. E. Grimaux and A. Arnaud.—A study of the velocity of decomposition of diazo-compounds by water, by MM. P. Th. Muller and J. Hauser. The law according to which sulphuric acid is decomposed is expressed by the formula  $C = \frac{A}{\theta} \log. nat. \frac{A}{A-x}$ , in which  $\theta$  is the time, C a constant, A the total nitrogen that can be evolved, and x the amount of nitrogen evolved. C is independent of the concentration.—Action of capryl iodide on trimethylamine in aqueous solution, in equimolecular proportions; formation, when heated, of dimethylcaprylamine; production in the cold of caprylene, by MM. H. and A. Malbot.—New synthesis of tartaric acid, by M. P. Genvesse. (See Notes.)—On the pyloric secretion of the dog, by M. Ch. Contejean.—New rings or intercalary rings of nerve-ducts (*tubes nerveux*), produced by the impregnation of silver, by M. Benjamin Segall.—On two new species of *Streptothrix*, Cohn, and on the place of this genus in the classification, by MM. C. Sauvageau and M. Radais.—History of the *Garcinia* of the sub-group *Xanthochymus*, by M. J. Vesque.—On the magnetic disturbance and the aurora borealis of March 6, 1892, by M. Th. Moureaux. Disturbances similar to those of

February 13–14, but less violent, were registered by the Parc Saint-Maur instruments on March 6–7.—On the magnetic storm of February 13–14, by M. H. Wild. A comparison of the records made by instruments at Pawlowsk with those obtained at Parc Saint-Maur shows that, although the recent magnetic storm commenced at approximately the same time, the variations at the two places were in the opposite directions. Other differences have been observed in the two records.—On the atmospheric, magnetic, and seismic disturbances of February 1892, by M. Ch. V. Zenger. The author has marshalled facts to show that magnetic storms, cyclones, snow-storms, discharges of atmospheric electricity, earthquakes, and volcanic eruptions occur simultaneously.—On three fossil human skeletons found in the Baoussé-Roussé grottoes, in Italy, by M. Émile Rivière.

## BOOKS RECEIVED.

BOOKS.—Phases of Animal Life: R. Lydekker (Longmans).—Meteorological Observations made at the Adelaide Observatory, &c., during the Year 1889 (Adelaide).—The Rationale of Mesmerism: A. P. Sinnett (Kegan Paul).—Zoological Record, 1890 (Gurney and Jackson).—Elements of Economics of Industry: Prof. A. Marshall (Macmillan).—Elementary Mathematical Astronomy: C. W. C. Barlow and G. H. Bryan (Clive).—The Dietetic Value of Bread: J. Goodfellow (Macmillan).—Air and Water: Prof. V. B. Lewes (Methuen).—Le Climat de la Belgique, 1891: A. Lancaster (Bruxelles, Hayez).—Soils and Manures: Dr. J. M. H. Munro (Cassell).—Longmans' School Geography for North America: G. G. Chisholm and C. H. LECTE, and edition (Longmans).—Precious Stones and Gems: E. W. Streeter, 5th edition (Bell).—The Oak: Prof. H. M. Ward (Kegan Paul).—The Labrador Coast: Dr. A. S. Packard (Kegan Paul).—Contribution à l'Étude de la Morphologie et du Développement des Bactériacées: A. Billel (Dulau).—Bateaux et Navires: Marquis de Folie (Paris, Bailière).—Diseases of the Nose: Dr. G. Macdonald, and edition (Watt).—Annals of the Royal Botanic Garden, Calcutta, vol. iii. (Calcutta).—A Short Text-book of Inorganic Chemistry: Dr. H. Kolbe, translated and edited by Dr. T. S. Humpidge, 3rd edition (Longmans).—Laboratory Practice: Dr. J. P. Cooke (Kegan Paul).—Catalogue of the Specimens illustrating the Osteology of Vertebrated Animals recent and extinct, contained in the Museum of the Royal College of Surgeons of England, Part 3, Class Aves: Dr. R. B. Sharpe (Taylor and Francis).

## CONTENTS.

	PAGE
Man in Nature. By J. G. G.	457
Furniture Woods	459
Our Book Shelf:	
Dary: "L'Électricité dans la Nature"	460
Lock: "The First Book of Euclid's Elements."—W.	460
Bothamley: "The Ilford Manual of Photography."	460
W.	460
Hughes and Williams: "The Advanced Class-book of Modern Geography"	460
Letters to the Editor:—	
Carpenter on Eozoon.—Sir J. William Dawson, C.M.G., F.R.S.	461
The Samoan Hurricane.—Everett Hayden; H. F. B.	461
Phonometry.—Dr. W. H. Besant, F.R.S.	462
On the Terms "Centrifugal Force" and "Force of Inertia."—George S. Carr	463
A Lecture Experiment in Surface Tension. ( <i>Illustrated</i> ).—E. D. Fridlander	463
The Orientation of Ancient Monuments.—Rev. Fred. F. Grensted	464
The Nickel Heat-Engine.—Rev. Frederick J. Smith	464
The Limpet's Power of Adhesion.—Percy A. Aubin	464
On the Variation of Latitude.—Robt. B. Hayward, F.R.S.	465
Ornithology of the Sandwich Isles. By Prof. Alfred Newton, F.R.S.	465
Prof. Bunsen and the Chemical Society	469
Notes	470
Our Astronomical Column:—	
Solar Investigations	473
New Double Star, 26 Aurigæ	473
Rotation of Jupiter	473
The New Star in Aurigæ	473
The Lick Spectroscope	473
A Bright Comet	473
Calculation of Trajectories of Elongated Projectiles. By Rev. F. Bashforth	473
Forthcoming Scientific Books	476
Scientific Serials	477
Societies and Academies	478
Books Received	480

THURSDAY, MARCH 24, 1892.

## THE HISTORY OF DETERMINANTS.

*The Theory of Determinants in the Historical Order of its Development.* Part I. Determinants in General. By Thomas Muir, M.A., LL.D., F.R.S.E. (London: Macmillan and Co., 1890.)

THE theory of determinants is in that borderland which separates the "pass" from the "honour" student of pure mathematics. In elementary text-books the subject is rarely more than introduced for the purpose of representing some result of geometry or analysis in a convenient, beautiful, and suggestive form. The essential properties of a determinant are not set forth, but the student is perhaps referred for further information to one or other of the two excellent treatises which are already at our disposal in the English language, viz. those of Mr. Muir and of Mr. R. F. Scott. The value of the idea thus given to a student of the shape and convenient use of a great analytical implement is beyond all question. His imagination and curiosity are alike excited, and the "trick" possibly prevents his passage through life under the delusion that all mathematics are comprised within the covers of the school-books. The honour student, as a matter of course, reads some work on the subject, and is as surely enchanted. He cannot fail to recognize the power and beauty of the notation. He observes that the object of his study is constructive in its nature. He becomes convinced that pure mathematics is one of the fine arts, and just as a beautiful picture gives pleasure to one who understands painting, just as a fine piece of sculpture delights one who understands modelling, so he sees unfolded to his intellectual eye an exquisite example of constructive art, which his previous mathematical reading has fitted him to understand and appreciate, and to regard as a beautiful object of contemplation. The theory of determinants is one of the most artistic subdivisions of mathematical science, and accordingly has never wanted enthusiastic admirers. It is most gratifying to find such an authority as Mr. Muir devoting his leisure to its historical development. Any mathematician taking up this volume would anticipate a treat, and he would not be disappointed. In this first instalment the reader is taken from Leibnitz (1693) to Cauchy (1841). Mr. Muir assigns a chief place of honour to Vandermonde (1771), who, in his "Mémoire sur l'Élimination" (Hist. de l'Acad. Roy. des Sciences), denoted a function formed from the coefficients of a set of linear equations by a symbolism which is at once recognized as a condensed form of the determinant matrix of the present day. He was the first to give a connected exposition of the theory, and to give the true fundamental properties of the new functions. His notation, moreover, was exceedingly good, and much superior to that adopted by some subsequent writers who overlooked or neglected his important work.

Vandermonde has also recently received justice, long denied him, in other branches of analysis, and there is now no doubt that the value and originality of his work entitle him to a place in the ranks of the mathematical pioneers of his time. Up to the close of the eighteenth century the most noteworthy additions were made by

Laplace, Lagrange, and Bezout. We find that Lagrange knew that the discriminant of a binary quadratic of the second order is an invariant of the linear transformation. He did not, however, express either the discriminant or the determinant of transformation in a determinant form. The author critically examines the claim of Laplace to be the discoverer of the expansion theorem. He finds that although the case in which as many as possible of the factors of the terms of the expansion are of the second degree had already been given by Vandermonde, and Laplace himself did not give a statement of the rule suited for general application, the claim can in the main be upheld. Hindenburg (1784) and Rothe (1800) took up the subject in Germany, and between them constructed an elementary theory of permutations. Rothe, it is interesting to observe, employed a graphical method which will remind the reader of Prof. Sylvester's modern constructive theory of partitions. Gauss (1801) followed, and then we come to the important papers of Binet (1811) and Cauchy (1812). These memoirs establish the multiplication theorem in its full generalization. The method adopted by Binet may be described as that of symmetric functions, which he uses freely. He employs identities of the type

$$\Sigma ab'c' = \Sigma a\Sigma b\Sigma c + 2\Sigma abc - \Sigma a\Sigma bc - \Sigma b\Sigma ca - \Sigma c\Sigma ab,$$

having reference to several systems of quantities. He was not, however, sufficiently acquainted with the theory of such functions; and was unable to supply rigid proofs of the theorems in determinants which, from his point of view, rested upon these identities. Nowadays, the identity in question will be recognized as the expression of an "elementary" symmetric function (single unitary, and having three parts in its partition) by means of symmetric functions each of which is expressible symbolically by a partition composed of one tripartite part. The law of the coefficients, undivulged by Binet, is now perfectly well known. It is, in fact, an easy generalization of the law by which, in the case of a single system of quantities, the elementary symmetric functions are expressed as functions of the sums of powers of the quantities. Cauchy at the same date (1812) introduced the idea of "fonctions symétriques alternées," which led him to a new symbolic definition of a determinant and to many valuable results. Mr. Muir devotes several pages to an examination of Cauchy's title to share with Binet the credit of the generalized multiplication theorem. He gives his decision against Cauchy, and probably the reader who closely follows the argument will find himself in accord with the historian. Notwithstanding this conclusion, Cauchy's memoir is excellent in quality and abundant in quantity; he "opened up a whole avenue of fresh investigation, and one cannot but assign to him the place of highest honour among all the workers from 1693 to 1812."

A retrospect is given of the period 1693-1812 accompanied by an interesting tabular record. As a means of reference the work appears to be absolutely perfect. Each new result as it appears is marked in Roman figures; and if the same result be obtained differently, or be generalized by a subsequent investigator, the same Roman figure is employed, followed by an Arabic numeral. It is found that to this point nearly every important advance is due to French mathematicians.

During the second period (1813-1841) the chief names are Cauchy, Schweins, Jacobi, and Sylvester; to these may be added Desnanot and Scherk, to whom fresh departures, of less extent, are due. Schweins himself may be said to have been discovered by Mr. Muir. This author (1825) deals with the subject under the title "Theorie der Producte mit Versetzungen." He made a notable generalization described as the transformation of an aggregate of products of pairs of determinants into another aggregate of similar kind. He further discussed special forms, and, it is clear, possessed a firm grasp of his subject.

The work of Jacobi and Sylvester, and the further work of Cauchy will be more or less familiar to mathematicians. Germany has passed to the first place; and the occurrence of Sylvester's name in the history marks a revival of learning in pure mathematics in England.

The volume is remarkable for the study it presents in nomenclature and notation. There is an extraordinary variety in the symbolism. It is easy to observe the distinctive characters of French and German notation that are so marked at the present day. It is well known that much lies in an appropriate notation. Every young mathematician with a predilection for original work should read this book, to note the power of suitable symbols, to grasp the reason of their power, and, above all, to see what to avoid.

The book also points a moral which is not far to seek. It would be easy to pick out many such phrases as, "was acquainted with the writings of very few of his predecessors"; "was unaware apparently of the existence of a theory of determinants"; "hasty, if not contemptuous, disregard of historical research." To this tendency to work on without proper attention to previous work is doubtless due in some measure the unfortunate multiplication of names and symbolisms which is so perplexing and irritating to a reader. This failure to collaborate with others can only retard the progress of the science. It is perfectly true that great original thinkers, like Gauss, Cauchy, Jacobi, and Sylvester, may take liberties of this kind; and the fact of their doing so may even be beneficial to the subject, as resulting in memoirs of more unfettered originality. But this is not so in the case of lesser men. In taking leave of this fascinating history one can look forward to Part II. with sincere pleasure, which is not diminished by the knowledge that the later developments have been largely due to our countrymen. We have yet to see Sylvester's most powerful investigations, and all Cayley's researches; and, finally, the successive steps by which the lofty heights of the theory of matrices and the theory of multiple algebra (involving the generalization of quaternions) have been attained.

P. A. M.

#### THE EVOLUTION OF MAN.

*Anthropogenie, oder Entwicklungsgeschichte des Menschen.* By Prof. Ernst Haeckel. Fourth Edition, revised and enlarged. Pp. i.-xxvi. and 1-906. (Leipzig: W. Engelmann, 1891.)

THE importance of the subject-matter of the book, the length of time that has elapsed since the appearance of the former editions, and the prominent

position held by the author, seem to call for more detailed notice of this work than is usually accorded to a new edition.

The "Anthropogenie," which was first published in 1874, is the third of the series of books in which Prof. Haeckel has attempted to determine the laws governing the form, structure, and mutual relations of living things, and to establish the general principles of biological science. The first of these, under the title "Generelle Morphologie," appeared in 1866, almost simultaneously with the completion of Herbert Spencer's "Principles of Biology." It is a comprehensive and ambitious work, which, in its author's words,

"constituted the first attempt to apply the general doctrine of development to the whole range of organic morphology, . . . and to introduce the Darwinian theory of descent into the systematic classification of animals and plants, and to found a 'natural system' on the basis of genealogy; that is, to construct hypothetical pedigrees for the various species of organisms."

It contains also the first systematic attempt to deal in detail with the ancestry of man, as regards the groups of animals lower than mammals. This is, perhaps, the most solid piece of work Prof. Haeckel has done; it contains much matter of great value, and discussions and speculations of extreme ingenuity and interest. Later discoveries have rendered much of it obsolete, but it still remains the most important work of its kind; and but for its somewhat cumbersome terminology, would be widely read even now. The "Natural History of Creation," first published in 1868, goes over a good deal of the same ground as the earlier work, but is written in a much more popular style, and aims at presenting in a form suited to the general reader the main arguments on which the Darwinian theory is based, together with a detailed application of the theory to the principal groups of animals, and an attempt to determine their mutual relations and lines of descent. The "Anthropogenie," the book now before us, is a more elaborate application of the same principles to the special problem of the evolution of man.

In the new edition the general arrangement remains much the same as before; but, in order to include the results of more recent investigations, a great part of the book has been re-written, and new chapters have been added on subjects that have attracted especial attention of late years, such as the Gastraea theory, the Coelom theory, and the nature and origin of segmentation. A large number of new figures have been inserted, and the genealogical tables, for which Prof. Haeckel has a special fondness, have been greatly increased in number, and in elaboration of detail.

The book, which is adapted rather for the general reader than the scientific student, is written in an attractive and popular style, and presents the main facts of vertebrate embryology in an intelligible and well illustrated form. As might be expected from his former writings, the main feature of Prof. Haeckel's work is a detailed exposition and vigorous defence of what he has named "the fundamental law of biogenesis," better known in this country as the recapitulation theory, according to which the actual or ontogenetic development of an animal is a repetition of the ancestral or phylogenetic

development of the species; or, to put it more simply, animals in their development climb up their own genealogical trees. This is now generally accepted by embryologists, but it has not always been so, and Haeckel reminds us, with justice, that he was one of the first to realize and teach the doctrine.

Prof. Haeckel has much to say on other points of theoretical interest. He protests strongly against Weismann's views with regard to heredity, pointing out that the very existence of germ-plasma is as yet a mere assumption, and maintaining that acquired characters may be and are actually transmitted. He objects equally strongly to the views as to the widespread occurrence of degeneration, which were first put forward by Dr. Dohrn; and on the much-debated question of the origin of Vertebrates he sides with those who fully accept the evidence afforded by the anatomy and development of Amphioxus; he admits the Vertebrate affinities of *Balanoglossus*, and looks for the ancestors of Vertebrates among the unsegmented Turbellarian worms. As a controversialist Prof. Haeckel is impressive rather than convincing. He hits hard and with effect, but prefers to counter rather than to parry the blows of his opponent. It is impossible to pass over without protest the terms in which he writes—it must be admitted under provocation—of the opinions and work of other investigators.

Prof. Haeckel's fondness for genealogical trees, and his facility in constructing them, are well known and have been much criticized, perhaps a little unfairly. Acceptance of the doctrine of evolution involves the recognition of a blood-relationship, near or remote, between any one animal and any other; and the only true classification is one which places this fact in the forefront, and adopts it as the basis on which the scheme is to rest. Genealogical tables undoubtedly stimulate inquiry, and so long as it is realized that they are necessarily in great part tentative or provisional, they probably will do more good than harm. It would be easy to take exception to many points in Prof. Haeckel's numerous and elaborate pedigrees, but it will be generally admitted that they are instructive, and often extremely suggestive, even though the conclusions may not meet with general acceptance.

The least satisfactory part of the book is that which deals with human embryology. No attempt whatever is made to explain the earlier stages of development; the special difficulties of the problem are absolutely ignored; the human gastrula is spoken of in a confident way, as though such a stage really existed; and the accounts of the development of the several organs and systems are too often taken from other animals. A student who relied on Prof. Haeckel's descriptions would obtain an entirely erroneous idea of the actual course of development of the human embryo.

Owing to the difficulty of obtaining material in proper condition for microscopical examination, our acquaintance with human embryology long remained imperfect; and the descriptions in text-books were largely based on our knowledge of other Vertebrates, and illustrated by figures from embryos of dogs, pigs, rabbits, or even chicken and dogfish. The time for all this is now past. During the last ten years our knowledge has advanced wonderfully; and although the earliest stages are still unknown,

it is not too much to say that our knowledge of the development of the human embryo, from a stage corresponding to a chick embryo at the commencement of the second day onwards, is as satisfactory, as complete, and as well illustrated as that of any other mammal.

For this great advance we are indebted almost entirely to the labours of German embryologists, and notably to the splendid work of Prof. His. Prof. Haeckel has in his volume many hard things to say of Prof. His, but is indebted to him for the only really good figures of human embryos which he gives, and would have materially improved his book had he studied more carefully the admirable descriptions of the Leipzig Professor. It is a matter for great regret that a book of 900 pages, having for its title, "*Anthropogenie, oder Entwicklungsgeschichte des Menschen*," should be allowed to appear in which the account of the actual development of the human embryo is so inadequate or even erroneous.

A. M. M.

#### OUR BOOK SHELF.

*Philosophical Notes on Botanical Subjects.* By E. Bonavia, M.D. With 160 illustrations. 368 pages. (London: Eyre and Spottiswoode, 1892.)

DR. BONAVIA'S philosophy is concerned with the evolution of vegetable organisms, and the gist of it is that all land-plants have descended from sea-weeds. He sees modifications and traces developments not obvious to ordinary observers, and he is prepared for derisive criticism. To quote from his preface:—"The fact is that, in this stage of existence, certain thoughts are often a great worry. One often cannot get rid of them. They turn up by day, they turn up by night, they turn up in the morning, and they haunt one at all times, and the only remedy for mitigating this worry of civilization is to commit them to paper. This done, there are several ways of disposing of your written thoughts. You can burn the papers they are written upon or otherwise destroy them, or you can leave them in a drawer as a legacy to your heirs! If by neither of these processes can you entirely give yourself repose, then the most effective way of ridding yourself of the worry of such thoughts is to have them published (if any publisher will perform this kind office), and to see them adversely criticized if anyone will even take so much trouble."

As the book before us testifies, Dr. Bonavia's worry reached the acute stage, and he is so far relieved as to have found a publisher; but we do not propose to gratify him by adverse criticism. We prefer giving one short extract from his sixteen "general conclusions":—

"Fifteenth:—The fig is obviously a further development of a conceptacle of a *Fucus* or other sea-weed. And there is every reason to believe that the oil-glands of the bark, leaves, and peel of the *Citrus*, and similar glands in other plants, are mere remnants of sea-weed conceptacles—that is, persistent features turned to other uses."

W. B. H.

*The Zoological Record for 1890.* Edited by Frank E. Beppard. (London: Gurney and Jackson, 1892.)

THIS is the twenty-seventh volume of the Record of Zoological Literature, and it has been prepared on the same plan as the volume published last year. First of all there is a list of works on general subjects, by J. A. Thomson. Then come the titles of writings on the following:—Mammalia, by R. Lydekker; Aves, by R. Bowdler Sharpe; Reptilia, Batrachia, and Pisces, by G. A. Boulenger; Tunicata, by W. A. Herdman; Mollusca, Brachiopoda, and Polyzoa, by P. C. Mitchell;

Crustacea, by C. Warburton; Arachnida and Myriopoda, by R. Innes Pocock; Insecta, by D. Sharp; Echinodermata, by E. A. Minchin; Vermes, by P. C. Mitchell; Coelenterata, by S. J. Hickson; Spongiæ, by E. A. Minchin; Protozoa, by C. Warburton. The utmost pains have been taken to make the lists complete and accurate, and to students of zoology they are practically indispensable. In the introduction to Mammalia, Mr. Lydekker notes that the number of new recent species is extraordinarily large. He adds, however, that this is "due to the elevation to specific rank of a host of North American forms which would be regarded by most zoologists as varieties." No fewer than forty of the "new species" belong to this category.

#### LETTERS TO THE EDITOR.

*[The Editor does not hold himself responsible for opinions expressed by his correspondents. Neither can he undertake to return, or to correspond with the writers of, rejected manuscripts intended for this or any other part of NATURE. No notice is taken of anonymous communications.]*

##### Sun Pillar.

A REMARKABLY well-defined instance of this phenomenon was seen by me at this place (460 feet above mean sea-level) this afternoon. At 5.32 p.m. the sun was sinking behind a thick layer of stratus cloud. There was a bank of dust haze, so defined as almost to resemble cirrus, which apparently formed a background to the clouds. When the phenomenon was first noticed, about three-quarters of the sun's disk was below the edge of the cloud bank; and from the centre of that portion of the disk visible there rose a tall column of brilliant light, extending upwards to about  $5^{\circ}$ , of the same width as the apparent

I had noticed, a quarter of an hour previously, that the rays of the sun, when behind a cloud, stood out in an unusually solid and clearly defined manner. There was a good deal of anti-cyclonic stratus (about 5000 feet) at the time, and the upper part of the atmosphere was more hazy than is usual with a north-east wind at this period of the year. At the earth's surface the wind had dropped to an almost perfect calm.

Lutterworth, March 5.

ANNIE LEY.

##### New Comet.

THE comet discovered here on the evening of Friday, March 18, is extremely small, though not very faint, and it has a decided central condensation or nucleus. Its position at about 8h. 30m., March 18, was roughly determined as R.A.  $341^{\circ}$ , Decl. N.  $59^{\circ}$ . The comet was therefore situated in Cepheus, and about  $3^{\circ}$  east-north-east of the star Delta in that constellation.

On March 19, at 8h., I reobserved the comet, and found its rate and direction of motion to be  $47'$  of arc east, and  $12'$  north. It will therefore shortly traverse Cassiopeia.

The comet was discovered with a 10-inch reflecting telescope, with eye-piece magnifying 40 times, and having a field of  $65'$  of arc.

W. F. DENNING.

Bristol, March 21.

[This is stated to be Winnecke's comet.—Ed.]

##### First Visible Colour of Incandescent Iron.

DURING the discussion which followed the reading of the paper on "Colour Photometry" by Captain Abney and General Feiting at the Royal Society on January 28, some interesting remarks were made by Lord Rayleigh as to the colour exhibited by heated iron when raised to such a temperature as only to be just visible in a dark room.

Lord Rayleigh stated that Weber, who, so far as I know, first drew attention to this subject, described the first visible light as a greenish-grey. Lord Rayleigh himself repeated the experi-

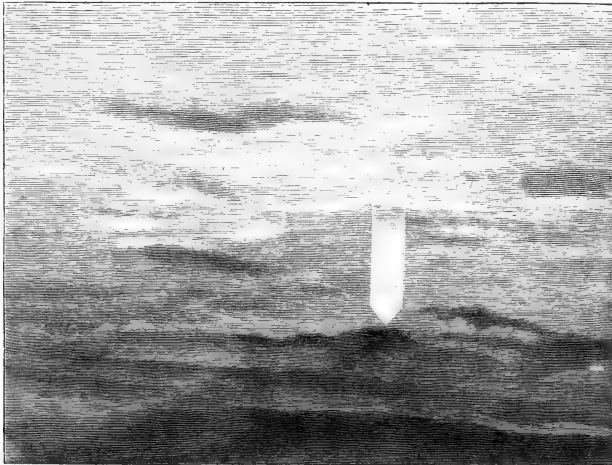

Sun pillar observed at Lutterworth.

diameter of the sun, and narrowing almost to a point as it touched the sun's rim. This convergence became more marked as the rest of the disk disappeared, until at the point at which the latter was finally lost to sight the apex appeared to rest on the edge of the cloud bank. The cone-shaped part at the base of the pillar was the most luminous portion, and glowed with a brilliant orange-red tint, which gradually merged into the yellow-white of the upper part of the column. The effect lasted for some minutes after the sun's disappearance, but the pillar lost its conical base and became less defined, while the clouds receding gave the appearance of the base of the pillar having risen in the sky.

NO. 1169, VOL. 45]

ment by making a piece of thin iron part of the wall of a very dark room, and heating the iron gradually by a Bunsen burner upon the other side. Lord Rayleigh could not satisfy himself as to the greenish tint, but was satisfied that no redness was apparent.

It struck me that a very convenient method of trying this experiment would be to introduce a round bar of heated iron into a thin sleeve, as shown in the annexed sketch, the sleeve being closed with a cover lined with asbestos. In this way the heat would slowly penetrate the sleeve, and the observers could note the first appearance of visibility and the changes of colour that followed.

I accordingly had two sleeves prepared, one of turned and polished iron, the other left with a thick coating of oxide. Two sets of experiments, in each of which six observers took part, were made. In each set of experiments three observations were made with the polished, and three with the oxidized sleeve. In each case the observers were in the dark room for some minutes before the experiments began.

In the first set of experiments the observers gave their opinion, at the conclusion of the experiments, as a body, that the first appearance of colour was a greyish-white; as the sleeve became hotter the colour was yellow, and gradually changed into orange. There was little or no difference between the observers as to the instant of visibility; it was generally over a minute before the sleeve became visible, the light generally showing first on the generating line of the cylinder between the eye and the axis.

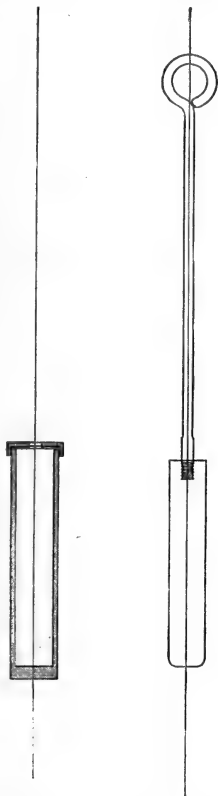

There was no difference in colour between the bright and the oxidized sleeves.

In the second set of experiments, the observers had no communication with one another, had no idea what colour they were expected to see, and their impressions were written down separately and independently. Their impressions were as follow, the observers being designated by  $\alpha$ ,  $\beta$ , &c. :—

( $\alpha$ ) First colour visible, grey white, second colour white with a little mauve, third pale rose, fourth orange. The above was the first experiment (polished metal). The other experiments showed some colour, but no mauve seen. In the last experiment (a very low heat) the colour never passed beyond a pale yellow.

( $\beta$ ) For all experiments, first grey white, second yellow, third orange. Last experiment, no orange.

( $\gamma$ ) For all experiments except last, first white, second yellow, third orange.

( $\delta$ ) For all experiments except last, first grey white, gradually becoming warmer till it reached orange.

( $\epsilon$ ) First white like phosphorus in the dark, gradually getting to rose, and winding up with a reddish-orange not reached in the last experiment.

( $\zeta$ ) First white with a dark shade, second yellow, third orange; no difference in any of the experiments except the last, where the temperature was lower, and the orange was not reached.

I may add that the temperature of the heating bar was a little reduced each experiment, the colours changed very slowly, and gave ample time for observation.

A. NOBLE.

Poincaré's "Thermodynamics."

M. TAIT ne répond pas à mon objection sous prétexte qu'elle est sans importance. Je maintiens que nous n'avons aucun moyen non seulement d'assigner l'origine des forces électromotrices Thomson, mais encore d'en constater l'existence. Si M. Tait veut répondre, et s'il connaît ce moyen, qu'il l'indique. Dans le cas contraire, s'il n'est pas en mesure de soutenir une quelconque de ses critiques, et s'il préfère un autre terrain de discussion, je suis prêt à l'y suivre.

Seulement je serai forcé d'être un peu plus long, car il me faudra passer en revue les trois reproches de M. Tait.

(1) La forme de mon ouvrage est trop mathématique. C'est là une appréciation personnelle dont il n'y a pas à discuter. Je veux bien d'ailleurs d'une polémique sur une question de doctrine, mais non d'un procès de tendance où je jouerais le rôle d'accusé.

Toutefois il est certain que je consacre relativement peu de place à la description des expériences, et on aurait le droit de s'en étonner si je n'en donnais l'explication. Mon livre est la reproduction textuelle de mon cours; or mes auditeurs avaient tous suivi déjà un cours de physique expérimentale, où ces expériences leur étaient décrites en détail. Je n'avais donc qu'à leur en rappeler brièvement les résultats.

(2) J'ai mal parlé de la définition de la température absolue. Autant que je puis comprendre, M. Tait ne trouve pas ma définition mauvaise, et n'en propose pas une autre; mais, dit-il, j'aurais dû parler des expériences de Joule et Thomson, qui permettent de mesurer la température absolue.

Or j'ai décrit ces expériences à la page 164, et j'ai montré à la page 169 comment elles permettent de déterminer la température absolue.

(3) J'ai laissé complètement de côté une explication mécanique du principe de Clausius que M. Tait appelle "the true (i.e. the statistical) basis of the second Law of Thermodynamics."

Je n'ai pas parlé de cette explication, qui me paraît d'ailleurs assez peu satisfaisante, parce que je désirais rester complètement en dehors de toutes les hypothèses moléculaires quelque ingénieuses qu'elles puissent être; et en particulier j'ai passé sous silence la théorie cinétique des gaz.

H. POINCARÉ.

Ornithology of the Sandwich Islands.

HAVING just returned from an exploring expedition into the interior of Australia, on my way home I lingered in this group of islands, and was sorry to find that some species which have been obtained here are now no longer to be found.

My attention has been called to an interesting paper by Prof. Newton in your last issue (p. 465), on this subject, which seems to imply that the ornithological collection made by Sir Joseph Banks during his voyage in the *Endeavour* with Captain Cook no longer exists, which I beg to be allowed to make a few remarks upon. After the return of Sir Joseph Banks he had several cases of birds carefully mounted and arranged according to the localities in which they were collected. In one group of land birds from Owhyhee, another case contained a number of specimens from Botany Bay, conspicuous in the centre of which was a very fine specimen of the Black Swan, which was shot by Captain Cook himself.

These cases were in the custody of the Linnean Society of London until 1863, when they formed part of their Natural History sale.

These cases have been carefully preserved, and are now in the museum of my ancestor, Mr. John Calvert, together with a number of cases of birds which formed part of Sir Ashton Lever's collection, amongst which are a few from the Pacific Islands. These last cases were purchased from the executors of the late Mr. M. Arnfield, of Catherine Street, Macclesfield,

about twenty-five years ago, being a very fine collection of many thousand ornithological specimens, with a quantity of interesting correspondence with Mr. J. Thompson, of Knowsley Aviary, Mr. Reid, of Doncaster, R. Dunn, of Hull, and many other naturalists of that period; these explain upon what terms he obtained the egg and a very fine specimen of the Great Auk.

ALBERT F. CALVERT.

63, Patshull Road, Kentish Town, March 19.

### Superheated Steam.

LORD RAYLEIGH (p. 438) rebuts my objection to the statement regarding the efficiency of a vapour-engine in which pure water is replaced by a saline solution, pointing out "that Maxwell's exposition of Carnot's engine applies *without the change of a single word*, whether the substance in the cylinder be water, mercury, or an aqueous solution of chloride of calcium." The latter italics are mine. In the statement objected to by me the aqueous solution of chloride of calcium was *in the boiler*, and what was *in the cylinder* was *superheated steam*, which is not included in the above list, so that the application of Maxwell's exposition is somewhat difficult. The greater part of the fresh water supplied to passengers in steamships is now produced by condensing the *superheated vapour of a saline solution*, and the culinary experience is that the substance which was in solution has all been left in the boiler. My contention, therefore, still stands—the saline mixture is not the working substance, and Carnot's law refers to the working substance only, and not to anything left in the boiler.

"In each case there is a definite relation between pressure and temperature." This is evidently merely a slip of the pen, the writer having for the moment forgotten that he was dealing with *superheated steam*, for which there is not a definite relation between pressure and temperature. The condition of superheated steam is completely defined when *both* pressure and temperature are given; but pressure is here a function of temperature-and-something-else, and temperature is here a function of pressure-and-something-else. That something-else may be volume or it may be energy, or, preferably, it may be entropy, but it must be something which cannot be predicted from pressure alone or from temperature alone.

"(So far as the substance is concerned), all that is necessary for the reversible operation of the engine is that the various parts of the working substance should be in equilibrium with one another throughout." No; for, in addition, it is necessary that the working substance should have only one pressure consistent with any given temperature. For this reason, superheated steam, however it may have been produced, can never be the working substance in a Carnot's engine. In the reversed cycle, when the steam is raised from a saline solution, from the beginning of the higher isothermal, the pressure would go on increasing until it became that due to saturated steam at the temperature of the superheat. This might be double the maximum pressure in the original cycle.

"The various parts of the working substance should be in equilibrium with one another throughout." The writer seems to say that the steam of a saline solution is a stable saturated vapour. It is H<sub>2</sub>O at a given pressure and temperature, and the condition of the substance is by this definition completely determined, and there is no alternative; but it is not stable. Say that the steam-space of the boiler is increased by adding a vertical cylinder alongside the boiler, open to it. On the bottom of that vessel the steam might condense—pure water—and the temperature of the steam immediately over this water would be that of saturated vapour at the same temperature, and from there all through the steam-space to the surface of the saline solution in the boiler the temperature would increase, and all would have the same pressure. There would be mechanical equilibrium, but not thermal equilibrium.

"At the upper limit, all the heat is received at the highest point of temperature,—but just as it would be if the evaporation were from a film of water upon a nearly bare combustion chamber crown. The plate is left in the boiler, and so is the salt, and in neither case would the steam exhibit a "state of things strongly contrasted with that which obtains when vapour rising from pure water is afterwards superheated." I have stated in my previous letter that the heat of evaporation is all received at identically the same temperatures as when it is raised from pure water at the same pressure, and the contrast is only as strong as that between occult and obvious. I have now

shown that the vapours must be identical from either beginning; and unless each carried a certificate of birth, I do not now see how it would be possible to tell one from the other.

London, March 12.

J. MACFARLANE GRAY.

### Phoronomy.

I THINK it will be admitted by all, that precision of language is of great importance in scientific terminology; and the letter of Dr. Besant, which appeared in your issue of last week (p. 462), certainly suggests strong reasons for employing the word *phoronomy* in the place of *kinematics*.

The word may at first sight appear strange to the present generation of mathematicians; but if it becomes acclimatized, its employment will appear as natural as the phrases *kinetic* and *potential energy*, in the place of such meaningless phrases as *vis-viva* and *force-function*.

When the medical profession require a new word, they almost always have recourse to the Greek language; and mathematicians and physicists would do well to follow their example, and in cases of doubt or difficulty to consult some eminent classical scholar. I must confess, that I have no sympathy with the attempts, which have occasionally been made, to introduce short words of Teutonic origin into scientific nomenclature, as such words have always appeared to me to be singularly deficient in point. A good example of this is furnished by the word *spin*, which Clifford attempted to introduce in the place of the phrase *molecular rotation*. The latter phrase, although a little long, exactly expresses the idea which it is intended to convey, viz. that the molecules of the fluid possess a motion of rotation as well as a motion of translation. The word *spin*, on the other hand, does not express any such idea, but is strongly suggestive of the juvenile, though not altogether unscientific, pastime of spinning peg-tops.

A. B. BASSET.

322 Oxford Street, W., March 18.

I HAVE before me the second edition of F. Redtenbacher's "Principien der Mechanik und des Maschinenbaues" (Mannheim, 1859), of which the first section is entitled "Die Bewegung als Erscheinung (Phoronomie)." Whether the term occurs already in the first edition (1852), I cannot affirm, but I remember very well that Redtenbacher, in his lectures in Carlsruhe, in 1858, insisted upon that term being distinct from "Dynamik" and "Kinematik." I conclude, therefore, that the majority of the 786 students of that year—among them many foreigners—also those of other years, were conversant with the term.

M. AM ENDE.

Westminster Chambers, 5 Victoria Street,  
London, S. W., March 19.

SOME other correspondent is pretty sure to be mentioning that Mr. W. H. Besant will find in Kant's *Metaph. Anfangsgründe der Naturwissenschaft* all the authority he could desire for his proposed use of the word "phoronomy." Kant regularly uses the word in the sense of the later "kinematic"; and he was man of science enough to justify anyone in following his lead.

G. C. R.

### The Tudor Specimen of Eozoon.

IN reference to the remarks made by Sir J. W. Dawson (NATURE, March 17, p. 461) on my paper on the Tudor specimen of Eozoon (*Quart. Journ. Geol. Soc.*, vol. xlvii, pp. 348-55), I should like to say that the whole point of that paper was that it was based on Sir J. W. Dawson's original type. The figure of this specimen has been repeatedly republished by Sir J. W. Dawson, and, in the absence of illustrations or details of other specimens from Tudor, upon its evidence alone rests the asserted occurrence of Eozoon in the Tudor limestone, and the great claims based thereupon. The value of other specimens from this locality was not rated very highly by Sir J. W. Dawson so recently as September 1888, when he remarked, "Without additional specimens,<sup>1</sup> and in the case of creatures so variable as the Foraminifera, it would be rash to decide whether

<sup>1</sup> And he previously refers only to "the specimen," "this very interesting specimen," "the fine specimen from Tudor," &c.



the differences above noted<sup>1</sup> are of specific value."<sup>2</sup> I may add that I have recently seen the specimens of Tudor Limestone exhibited in the Peter Redpath Museum, and my estimate of their value coincides exactly with that of Sir J. W. Dawson in 1888. As Sir J. W. Dawson most kindly promises his assistance to other workers, perhaps he would submit to some of them any specimens from Tudor which he regards as more conclusive than his original type.

It would seem rather unnecessary for anyone to trouble to infer from my paper that Sir J. W. Dawson has "regarded the Madec and Tudor specimens as 'Lower Laurentian,'" when that is so directly stated by Sir J. W. Dawson in his description of his figure; viz. "Specimen of *Eozoon canadense* embedded in a dark-coloured homogeneous limestone occurring in the Lower Laurentian series at Tudor, Canada West" (*Quart. Journ. Geol. Soc.*, vol. xxiii. p. 265).

J. W. GREGORY.  
British Museum (Natural History), S. W.

### The Theory of Solutions.

In his last letter (*NATURE*, March 3, p. 415) Prof. Ostwald repeats his opinion that a theory is "a complex of laws, grouped around and derived from a main law," and infers from my letter that what I term a theory he would term a hypothesis.

If this were the whole point at issue, I could meet it in no better way perhaps than by referring Prof. Ostwald to his own works. For example, in his "Outlines of General Chemistry," are to be found not only numerous instances of the use of the word theory in its ordinary and accepted sense (e.g., p. 58) but also cases in which it is employed as synonymous with hypothesis (e.g., p. 187).

With regard to the definition of solutions as mixtures, Prof. Ostwald maintains that even if hydrates are formed in a solution, the solution is finally a mixture of the hydrates and the remaining solvent. The real question involved is unaffected by this explanation. There is no doubt whatever that to the majority of readers the definition, without any qualifying clause, that solutions are mixtures leads to one conclusion and no other—namely, that between solvent and dissolved substance there is no interaction of a chemical nature. Prof. Ostwald has in his letters stated that in some cases he considers such interactions occur; he has also stated that between chemical and physical processes he knows of no distinction. The definition is at variance with both these views, and it seems but fair to conclude that such discordant statements tend in no way to obviate that misconception which Prof. Ostwald so often deplores.

In defence of the application of van der Waals's equation to solutions, a process questioned by me in my letter, Prof. Ostwald states that van der Waals himself has taken up this very question. The method by which van der Waals approaches the subject, curiously enough, furnished the main grounds for my objections. The most superficial comparison of the complex formula which van der Waals deduces for a mixture of two substances, with such an application of his simple gas equation to a solution as that given in Prof. Ostwald's book, is ample justification for my strictures. But apart even from such evidence as to the inadequacy of the application, the form which it is finally made to assume is in itself a proof of its incompleteness. By judicious simplification the application is made to take the shape of a linear equation in which "pressure forces due to the interactions of molecules are absent." That is to say, the cohesion of solvent and dissolved substance, and the mutual reactions of both, are alike ignored. Further comment on such a method of accounting for the phenomena of solutions appears to me to be superfluous.

J. W. RODGER.  
London, March 7.

### The Limpet's Strength.

THE limpet experiments of your esteemed correspondent, Mr. Percy Aubin, as reported in *NATURE* of March 17 (p. 464) would have been still more interesting and instructive had he weighed the animals deprived of their shells.

On April 10, 1890, I published my experiments showing that the shell-less limpet pulls 1984 times in the air its own weight, and about double when immersed in water.

<sup>1</sup> i.e. between the specimen from Tudor and those from other localities.

<sup>2</sup> "Specimens of *Eozoon canadense*," Mem. Peter Redpath Mus., 1888, p. 43.

Fasting fleas on an average pull 1493 times their own dead weight.

Other experimenters give the pulling power of the shell-deprived *Venus verrucosa* of the Mediterranean, a cockle-like creature, at 2071 times the weight of its own body.

The force required to open an oyster appears to be 1319½ times the weight of the shell-less oyster.

J. LAWRENCE-HAMILTON, M.R.C.S.  
30 Sussex Square, Brighton, March 19.

### Technical Education for Novelists.

AMIDST the many schemes for technical education, could you not put in a plea for the "author of the popular novel"? Perhaps the need will best appear from these illustrations taken from the first 100 pages of a recently published and loudly heralded work.

(1) Scene—Kinder Scout, Derbyshire. Date—"after the snows and rains of early April," 1864. Time—"after 8 p.m." "It was a clear, frosty night, promising a full moon."

(2) Same place, *Easter Eve*, 1864. "The wooded sides of the great moor were fading into dimness, and to the east a young moon was rising." W.

March 12.

### THE ORIGIN OF THE YEAR.

#### I.

IT would seem that in the dawn of civilization it was not at all a matter of course that the sun should be taken as the measurer of time, as it is now with us; and in this connection it is worth while to note how very various the treatment of this subject was among the early peoples. Thus, for instance, it was different in Egypt from what it was in Chaldæa and Babylonia, and later among the Jews. In the Egyptian inscriptions we find references to the moon, but they prove that she occupied quite a subordinate position to the sun; while in Chaldæa it would seem that the moon was the chief thing worshipped, and it was thus naturally the chief means used for measuring time, and so far as months were concerned, this, of course, was quite right. In Chaldæa, too, where much desert travel had to be undertaken at night, the movement of the moon would be naturally watched with great care.

An interesting point connected with this is that, among these ancient peoples, the celestial bodies which gave them the unit period of time by which they reckoned were practically looked upon in the same category. Thus, for instance, in Egypt the sun being used, the unit of time was a year; but in Chaldæa the unit of time was a month, for the reason that the standard of time was the moon. Hence, when periods of time were in question it was quite easy for one nation to conceive that the period of time used in another was a year when really it was a month, and *vice versa*. It has been suggested that the years of Methuselah and other persons who are stated to have lived a considerable number of years were not solar years but lunar years—that is, properly, lunar months. This is reasonable, since if we divide the numbers by 12 we find that they come out very much the same length as lives are in the present day.

There seems little doubt that the country in which the sun was first definitely accepted as the most accurate measurer of time was Egypt.

"The Egyptians," says Ranke in the first chapter of his "Universal History," which is devoted to Egypt, "have determined the motion of the sun as seen on earth, and according to this the year was divided, in comparison with Babylon in a scientific and practically useful way, so that Julius Cæsar adopted the calendar from the Egyptians and introduced it into the Roman Empire; the other nations followed suit, and since then it has been in general use for seventeen centuries. The calendar may be considered the noblest relic of the most ancient times which has influenced the world."

A study of the Egyptian monuments has shown most conclusively that towards the end of the ancient empire the Egyptians possessed a year as accurate for calendar purposes as our own, and that they had been led up to the knowledge of its true length by successive steps.

As we shall show further on, this earliest of all years that we know of in history began at the summer solstice. Since one of the oldest temples at Thebes is oriented to sunset at the summer solstice, we should be not at all surprised if investigation shows that when that temple was built, more than 3000 years B.C., the Egyptian year really began in what we should call our summer. We have ample evidence of this. And I think there is little doubt also that when Stonehenge was built it certainly was built by people who began their year with the summer solstice, which is the time of the year in which in many countries it is the habit still to light fires upon hills and so on. If we look up the records of the peoples that lived, say, during the 1000 years preceding the birth of Christ, we find that the different races began their year at different times, and even that the same race at different times began their year differently; the choice lay among the equinoxes and the solstices.

Wherever the ancient Egyptians came from, whether

Beginning with the inundation (summer solstice) we have—

- (1) The season or *tetramene* of the inundation,
- (2) " " " sowing,
- (3) " " " harvest.

From the earliest times the year was divided into twelve months, as follows:—

Inundation ...	Thoth ...	End of June (Gregorian).
	Phaophi ...	July.
	Athyr ...	August.
	Choiak ...	September.
	Tybi ...	October.
Seed time ...	Menchir ...	November.
	Phamenoth ...	December.
	Pharmouthi ...	January.
	Pachons ...	February.
Harvest ...	Payni ...	March.
	Epiphi ...	April.
	Mesori ...	May.

Now whether the Egyptians brought their year with them or invented it in the Nile valley, there is a belief that it at first consisted of 360 days only, that is 5½ days too little. It is more likely that they brought the lunar

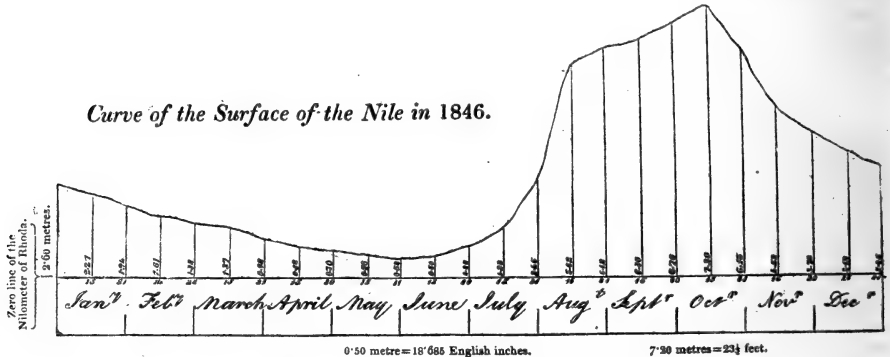

FIG. 1.—The annual rise and fall of the Nile (from Horner).

from a region where the moon was the time-measurer of not, so soon as they settled in the valley where the Nile then as now like a pendulum slowly beat the years by its annual overflows at the summer solstice, the solar basis of their calendar was settled.

We can well understand, therefore, since the whole life of the country depends upon the river, and all the energies of the inhabitants are connected with the work to be done during its rise and fall, that the moment of the commencement of the inundation, about the time of the summer solstice, should be chosen as the beginning of the year. Hence the perpetual reference to Solstice and Nile flood in the Egyptian annals.

It might be imagined at first sight that, as the year was thus determined, so to speak, by natural local causes, the divisions or seasons would be the same as those which Nature has given us. This is not so. Egypt is too near the tropics, and the local conditions are too different from our own, to permit of the application of our seasonal divisions of the year.

As Egypt, in the description quoted by Krall, "first appears like a dusty plain, then as a fresh-water sea, and finally as a bed of flowers," so the year is divided into three seasons instead of four.

month with them, taking it roughly as 30 days (30X12=360), than that they began with such an erroneous notion of the true length of the solar year, seeing that in Egypt, above all countries in the world, owing to the regularity of the inundation, the true length could have been so easily determined, so soon as that regularity was recognized.

We must not in these questions forget to put ourselves in the place of these pioneers of astronomy and civilization; if we do this, we shall soon see how many difficulties were involved in determining the true length of such a cycle as a year, when not only modern appliances, but all just ideas too, were of necessity lacking.

Still it is right that I should state that all authorities are not agreed as to the use of this year of 360 days. Ideler<sup>1</sup> considers it very doubtful. Krall,<sup>2</sup> however, urges that a certain inscription (the trilingual inscription of Tanis) expressly refers to it.

He adds to this some evidence, which he considers confirmatory, from religious usages. Thus at Philoe, in the temple of Osiris, there were 360 bowls for sacrifice, which were filled daily with milk by a specific rotation of priests. At Acanthus there was a perforated cask

<sup>1</sup> "Chronologie," i. p. 70.

<sup>2</sup> "Studien zur Geschichte des alten Aegypten," i. p. 16.

into which one of the 360 priests poured water from the Nile daily. Krall adds:—

"It is probable that the year of 360 days dates from the time before the immigration into the Nile valley, when the Egyptians were unguided by the regular recurrence of the Nile flood. In any case, this must soon have convinced the priests that the 360-days year did not agree with the facts. But it is well known to everybody familiar with these things how long a period may be required before such determinations are practically realized, especially with a people so conservative of ancient usages as the Egyptians."

Supposing the use of this 360-day year to have been universal, it is perfectly certain that the Egyptians, now in this part of the Nile valley, now in that, must have got their calendar into the most hopeless confusion, compared with which "the year of confusion" was mere child's-play, and that the exact determination of the time of sowing, reaping, &c., by means of such a calendar would have been next to impossible.

As each year dropped 5½ days, it is evident that in about seventy years ( $\frac{365 \cdot 25}{5 \cdot 25}$ ) a cycle was accomplished,

in which new year's day swept through all the months. The same month (so far as its name was concerned) was now in the inundation time, now in the sowing time, and so on. Of fixed agricultural work for such months as these there could be none.

It must have been, then, that there were local attempts to retain the coincidences between the beginning of the year and the Nile flood and solstice; intercalation of days or even of months being introduced, now in one place, now in another; and these attempts, of course, would make confusion worse confounded, as the months might vary with the district, and not with the time of the year.

That this is what really happened is, no doubt, the origin of the stringent oath required of the Pharaohs in after times, to which I shall subsequently refer.

This year of 360 days had naturally to give way, and it ultimately did so in favour of one of 365. The precise date of the change is not known, but it is referred to in inscriptions of the time of Amenemha I. (circ. 2400 B.C.). This, of course, does not exclude the possibility, indeed even the probability, that it was introduced much earlier. The five days were added as epacts or epagomena; the original months were not altered, but a "little month" of five days was interpolated at the end of the year between Mesori of one year and Thoth of the next.

When the year of 365 days was established, it was evidently imagined that finality had been reached; and mindful of the confusion which, as we have shown, must have resulted from the attempt to keep up a year of 360 days by intercalations, each Egyptian king on his accession to the throne bound himself by oath before the priest of Isis, in the temple of Ptah at Memphis, not to intercalate either days or months, but to retain the year of 365 days as established by the Antiqui.<sup>2</sup> The text of the Latin translation preserved by Nigidius Figulus, cannot be accurately restored. Only thus much can be seen with certainty.

To retain this year of 365 days then became the first law for the king, and indeed the Pharaohs thenceforth throughout the whole course of Egyptian history adhered to this year, in spite of their being subsequently convinced, as we shall see, of its inadequacy for a long period. It was a Macedonian king who later made an attempt to replace it by a better one.

The years of 360 and 365 days to which we have so far referred are termed in the inscriptions the "little" and "great" years respectively.

How, then, was this 365-day year, which had been introduced with such pomp and circumstance, regulated? This brings us to a new point.

#### *The Heliacal Rising of Sirius.*

I have insisted upon the perfect regularity of the rise of the Nile affording the ancient Egyptians, so soon as this regularity had been established, a nearly perfect way of determining the length of the year.

It is also clear that so soon as the greatest northing and southing of the sun rising or setting at the solstices had been recognized, and that the intervals between them in days had been counted, a still more accurate way would be open to them, especially if, as I believe, the observations of the solstitial risings or settings were made in temples (or observatories) accurately oriented to the proper amplitude.

In this way, then, the great natural festival of the year would be the nearly coincident commencement of the inundation and the summer solstice.

As I have said, the solstice might have, one may say *must* have, occurred with greater regularity than the rise of the river, so that as accuracy of definition became more necessary the solstice would be preferred. The solstice was common to all Egypt, the commencement of the inundation was later as the place of observation was nearer the mouth of the river.

Now it seems as if among all ancient peoples each sunrise, each return of the sun—or of the sun-god—was hailed, and most naturally, as a resurrection from the sleep—the death—of night: with the returning sun, man found himself again in full possession of his powers of living, of doing, of enjoying. The sun-god had conquered death, man was again alive. Light and warmth returned with the dawn in those favoured eastern climes where man then was, and the dawn itself was a sight, a sensation, in which everything conspired to suggest awe and gratitude, and to thrill the emotions of even uncivilized man.

What wonder, then, that sunrise was the chief time of prayer and thankfulness? But prayer to the sun-god meant, then, sacrifice, and here a practical detail comes in, apparently a note of discord, but really the true germ of our present knowledge of the starry heavens which surround us.

To make the sacrifice at the instant of sunrise, preparations had to be made, beasts had to be slaughtered, and a ritual had to be followed; this required time, and a certain definite quantity of it; to measure this, the only means available then was to watch the rising of a star, the first glimmer of which past experience had shown preceded sunrise by just that amount of time which the ritual demanded for the various functions connected with the sunrise sacrifice.

This, perhaps, went on every morning, but beyond all question the most solemn ceremonial of this nature in the whole year was that which took place on New Year's morning, or the great festival of the Nile-rising and summer solstice, the 1st of Thoth.

How long these morning and special yearly ceremonials went on before the dawn of history we, of course, have no knowledge. Nor are the stars thus used certainly known to us; of course any star would do which rose at the appropriate time before the sun itself, whether the star was located either in the northern or southern heavens. But in historic times there is no doubt whatever about the star so used. The warning-star watched by the Egyptians at Thebes, certainly 3000 B.C., was Sirius, the brightest of them all, and there is much evidence that Sirius was not the star first used.

"Besides the solstice and the beginning of the Nile flood, there was an event in the sky which was too striking not to excite the general attention of the Egyptian priesthood. We also know from the newly-discovered

<sup>1</sup> *Loc. cit.*, p. 20.

<sup>2</sup> Mommsen, "Chronologie," p. 253.

inscriptions from the ancient empire that the risings of Orion and Sirius were already attentively followed and mythologically utilized at the time of the building of the pyramids.<sup>1</sup>

J. NORMAN LOCKYER.

(To be continued.)

### THE WINTER STORMS OF NORTHERN INDIA.

THE physical constitution and history of the storms of India and Indian Seas is a subject which, almost from his first association with the Indian Meteorological Department, Mr. Eliot has made peculiarly his own. Besides nine elaborate, and, as far as possible, exhaustive, memoirs and reports on the history of particular storms, two on the tracks and periodicity of the cyclones of the Bay of Bengal during the ten years 1877-1886, and an admirable hand-book, in which he has summarized, for the guidance of seamen, the characteristic features and behaviour of these storms, his annual reports on the meteorology of India have always been replete with the results of his studies of the storms of the current year; and to him is mainly due that development which has been effected in the system of storm warnings for the coasts of India in recent years, and has rendered it one of the most efficient and comprehensive organizations for that purpose now in operation in any part of the world.

Like most other features of the climate, the storms of India differ very greatly in their leading characteristics at different seasons of the year. We have, in the first place, the well-known cyclones and cyclonic storms of the Bay of Bengal and the Arabian Sea, which are most frequent when the summer monsoon is at its height, and most severe at its commencement and termination. These are generated over some part of the tropical sea north of latitude 6°, and travel, as is now well known, on tracks between west and north—most frequently north-west or west-north-west; sometimes, however, in the spring and later months of the year, recurring to north-north-east or even north-east, as they approach the tropic. In virtue of their severity and destructiveness, these storms have attracted far more attention than any others, and not only Piddington's, but also the writings of most of his successors, have been almost exclusively devoted to them.

Of a very different type are the storms that bring the rainfall of the cold season and the earlier spring months to Northern India. It would be incorrect to speak of these as the storms of the winter monsoon (unless the term be understood, in its strictly etymological sense, as merely the name for a season of the year), for during their passage the northerly winds are suspended over a great part of India, and, with the rarest exceptions, they never penetrate far into the tropics. These storms, if they travel, always move from west to east. They have the usual cyclonic constitution, but the winds have but little force; and it was not until the preparation of daily weather charts for the first time showed their true nature, that this fact was even suspected.

Many of the features of these cold-weather storms are very striking and characteristic, and, as has been remarked by Mr. Eliot in his reports for 1888 and 1889, the temperature of Northern India in the cold season is chiefly determined by their number and character. Each of them is preceded by a wave of high temperature, and followed by a cold wave; except, indeed—and the exception is instructive—when the course of the storm is so far south of the Himalayas that little or no snow falls on the mountains (see "Climates and Weather of India," p. 206).

In these cases, which are, however, exceptional, the cold wave is sometimes evanescent. On the other hand, as Mr. Eliot remarks, "the intensity and period [of the cold wave] largely depend on the amount of rainfall in Northern India and of the snowfall on the Himalayan mountain regions, and the height to which the snow-line has descended." As a rule, therefore, the cold wave follows the storm. Mr. Eliot gives, in his report, a table of the changes of temperature from day to day from January 20 to February 7, 1889, which includes two very characteristic illustrations of this phenomenon, and which therefore we extract. The figures show the variations of the observed mean temperature of each day from the average of many years for the same day. The crest of each warm wave is emphasized by strong type and the trough of each cold wave by italics.

The history of these two storms is as follows, and it exhibits one or two remarkable and suggestive features, which will presently be noticed more particularly. The first disturbance originated (or made its first appearance in India) on January 22. There were two separate centres and areas of disturbance, one of which covered the Punjab Himalaya and adjacent plains from Sialkote to Roorkee. This filled up [apparently] on the 23rd, after giving moderate snow on the hills and light showers on the adjacent plains. The other originated in Rajputana, and advanced, on the 23rd and 24th, in an easterly direction, across Northern India into Burma. It gave moderate general rain to the North-West Provinces and Central India, and light showers to Behar, Bengal, and Assam. This first storm was therefore of very moderate intensity. The snowfall and rainfall were but slight, and in the Punjab, Bengal, and Burma insufficient to bring down the temperature below the normal average.

The second disturbance was one of greater intensity, but like its predecessor had a double centre. One part consisted of a shallow depression, which passed into Sind from Baluchistan on the 28th, advanced through Central India, Behar, and Bengal, on the three following days, and into Burma on February 1, where it slowly filled up during the next three days. The other part was a deep depression, which formed in the Northern Punjab on the evening of the 28th, and during the next thirty-six hours marched slowly to the south-east along the southern face of the Punjab Himalayas. It filled up very rapidly on the evening of the 30th, and morning of the 31st of January, in the South-Eastern Punjab. The double disturbance gave a very heavy fall of snow over the whole of the Western Himalaya, bringing the snow-line down to 3500 or 4000 feet, and also general rain to nearly the whole of Northern and Central India, which was greatest in amount in the Punjab, the North-West Provinces, and Behar. As is shown by the table (see next page), the fall of temperature after this storm was proportionately great, amounting to 9½° in the Punjab, and to 14° or 15° on the mean of the day in Guzerat, Central India, and the Central Provinces. It continued three or four days after the weather had cleared up, so that the trough of the cold wave followed the crest of the warm wave after an interval of five or six days, and each occupied three or four days in passing from the Punjab to Burma. Mr. Eliot gives eight charts in illustration of these waves, of which we reproduce those for January 30 and 31 and February 1. They are projected for the observed temperatures at 8 a.m. of those days, and show, not the temperatures themselves, but the amounts by which these deviate in excess or defect from the averages of many years at the same hour. The isabnormals of deficient temperature are represented by broken, those of excessive temperature by continuous lines.

Mr. Eliot remarks that in the warm waves the greatest excess is generally exhibited by the night temperatures; and in a table which he gives of the deviations of the daily maxima and minima from their respective normal

<sup>1</sup> Krall, *op. cit.* p. 45. See also Brugsch, "Aeg. Zsit." 1881, p. 1, *segg.*

DAILY TEMPERATURE ANOMALIES (DEG. FAHR.).

February

January

PROVINCES.

PROVINCES.	January										February								
	20th.	21st.	22nd.	23rd.	24th.	25th.	26th.	27th.	28th.	29th.	30th.	31st.	1st.	2nd.	3rd.	4th.	5th.	6th.	7th.
Punjab	-4.2	-0.5	+4.0	+2.3	+0.1	+0.2	+2.2	+2.9	+3.2	0	0	-2.2	-3.4	-3.5	-6.1	-4.3	-1.8	-0.6	+3.5
Sind and Rajputana	-4.1	-2.1	+2.8	+5.2	-0.6	-0.9	+3.2	+4.6	+4.1	+4.4	+3.6	-3.8	-1.6	-2.6	-6.4	-5.7	-0.7	+4.9	+5.4
Guzerat and Central India	-0.2	+1.4	+4.8	+7.9	-1.8	-0.8	+1.8	+4.8	+6.6	+9.5	+10.9	+2.6	-3.3	-2.3	+0.4	-4.4	-2.9	+1.8	+4.0
North-West Provinces	+2.5	+0.2	+0.9	+5.3	+4.3	-2.2	-0.8	-1.5	+1.7	+5.0	+6.4	+0.5	-1.5	-2.5	-4.1	-5.2	-5.0	-2.3	+1.0
Central Provinces	+5.1	+4.7	+6.5	+8.6	+3.2	-0.7	+3.0	+5.6	+7.3	+9.7	+10.4	+6.0	-3.2	-3.1	+1.5	-1.1	-4.1	-0.7	+4.0
Bengal	+6.8	+2.9	+0.9	+1.3	+8.4	+1.8	+1.6	+0.6	+2.3	+3.9	+6.1	+4.2	+3.9	-2.4	-3.2	-2.4	-5.0	-4.2	-2.6
Burma	+2.0	+1.5	+1.4	+1.3	+2.5	+2.6	+2.5	+1.2	+1.7	+2.2	+2.6	+3.1	+4.0	+3.7	+1.3	+0.6	+0.4	-1.5	-0.1

values, it appears that those of the latter are from one and a half times to nearly twice as great as those of the former. On the other hand, in the cold waves which follow the storm, the day temperatures frequently show a greater relative depression than those of the night-time, indicating therefore that the nocturnal radiation under a clear sky is far from being the only cooling agency operative.

Notwithstanding this latter feature, the cold waves often bring about an inversion of the normal temperature relations between the hills and the plains, and that in a very remarkable degree. This was observed on no less than eleven nights in January 1889; and a very interesting paper on the subject was contributed by Mr.

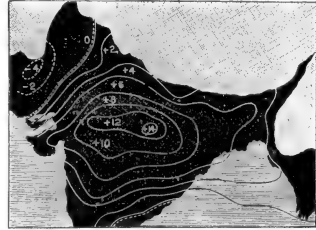

January 30.



January 31.



February 1.

Temperature isabnormals of twenty-four hours preceding 8 a.m.

Eliot to vol. lix., Part ii., of the Journal of the Asiatic Society of Bengal. On one occasion, the figures of which are given, not only was the minimum night temperature of the hill stations (at elevations between 6000 and 8000 feet) from 8° to 13° higher than on the adjacent plains, but actually higher than anywhere on the Indo-Gangetic plain except only the coast districts of Bengal.

Before noticing the barometric features of these storms, let us see what is the probable explanation of their striking vicissitudes of temperature. The weather charts and reports

show that for a day or two previously to the appearance of the storm-centre in North-Western India light southerly or easterly winds prevail over Northern India, accompanied with increasing but not dense cloud, and a steady rise of vapour tension, which, as Mr. Eliot points out, is only in part explained by the increase of temperature. The distribution of the cloud is well marked and characteristic. "An examination of a large number of these storms shows that they invariably give light cloud to the south-east of their tracks, moderate cloud to the east, and overcast skies to the north. In fact the largest development of cloud usually occurs in the northern and north-eastern portion of the depression, and at a considerable distance to the north of the depression, as indicated by the isobars, . . . and usually in the hill districts, and adjacent plain districts of Northern India. Hence the cloud distribution appears to indicate that the ascensional motion accompanying these storms commences to the south, and proceeds slowly in the eastern quadrant, and is completed in the northern quadrant. The cloud thins off rapidly in the north-west quadrant, and in the west and south-west portions of the depression the skies are clear." These observations are very important; they show that the damp, warm air of southerly origin is absolutely restricted to the eastern side of the depression, for it is, so to speak, hall-marked by its freight of vapour, and this manifests its presence, and also indicates the region of its ascent and withdrawal from the earth's surface, by forming a thick cloud canopy, on the north and north-east chiefly. This too, of course, is the region of heaviest rain and snow fall.

The wave of warmth that precedes the depression is thus clearly explained by the unseasonable replacement of northerly by southerly winds; and since the warmth depends not only on the derived temperature of the air, but also, and in a very great measure, on the check given to nocturnal radiation by cloud and vapour, while it is not dense enough greatly to obstruct the solar rays, it is sufficiently obvious why the night temperatures should show a greater excess than those of the day-time.

For the reduction of the temperature in the cold wave that follows the depression, three distinct causes may be assigned: viz. the contact of a snow surface down to low levels on the Himalaya and Afghan mountains, from which are drawn the north-west winds of the western half of the storm; the evaporation of the rain that has fallen on the plains, and is rapidly taken up by the very dry air that has descended from the mountains; and lastly, the increased nocturnal radiation in this dry atmosphere under a cloudless sky. Of these it would seem that the first and second are the most influential. This seems to be indicated by the facts already quoted—that the intensity of the cold largely depends on the rain and snow fall, and the level to which the latter descends; also that when the storm centre lies so far south of the mountains that little or no snow is precipitated on them, the cold wave does not always follow. It is further supported by the fact noticed by Mr. Eliot, that the relative depression of the day temperature in the cold wave is frequently greater than that of the night hours. This effect of the snow is the more remarkable, when we consider that, in descending to the level of the Indo-Gangetic plain, the air must, of course, be dynamically heated about  $5\frac{1}{2}^{\circ}$  for each thousand feet of descent. Nearly all this heat must have been expended in melting the snow, since the air arrives at the level of the plains dry and cold; so much so, indeed, that the further cooling it undergoes, in consequence of the evaporation of the rainfall and nocturnal radiation, brings

down the night temperature of the plains sometimes as much as  $13^{\circ}$  below that of mountain ridges at 7000 feet.

It remains to notice the barometric features of these storms, for, if less striking than the vicissitudes of temperature that accompany them, they afford matter of much interest, and suggest questions of a wider bearing than such as have reference merely to the local circumstances of the sub-tropical zone. The barometric depression of these winter storms is as a rule very small, and the gradients are very low. On the Indian weather charts the isobars are laid down for increments of one-twentieth of an inch; but it is seldom that the storm vortex, when launched on the plains of India, is encircled by more than one or two closed isobars, and sometimes its position can only be gathered from the figures in the accompanying table of the reduced barometric readings, or recognized by the oblique inflection of the wind arrows. Such was the case with both the January storms, noticed above, which travelled across India to Burma, and also the Punjab secondary depression of January 22, 1889. But that which formed in the Punjab on January 28, and which is described as a stationary storm, was of a much more pronounced character, and for three days determined the leading features of the distribution of pressure all over North-Western India, the isobars being only slightly modified by the travelling depression further south. Of a similar type was the storm at the end of January 1883, of which illustrations are given in the report on the meteorology of India for that year. This too appears to have lingered in the angle of the Punjab inclosed by the Himalaya and the Afghan mountains, and the question forces itself upon us, whether there is not something in the physical features of this part of the country that favours the development of such vortices, and detains them while the feebler and shallower depressions that form part of the same general disturbance, pursue their course eastward across the plains. Mr. Eliot remarks on the effect of the Himalaya in causing a forced ascent of the southerly vapour-bearing winds, thus localizing the maximum precipitation on the north and north-east of the depression; and it is possible also that the angle at which the mountain chains meet on the north of the Punjab, inclosing the plain of that province, may not be without its influence in favouring the development and detention of the vortex.

It is still very obscure what are the general causes that determine the appearance of these storms in India. At one time it seemed to me probable that their origin was to be sought for in the local conditions of India itself, and even now I see no reason to question that, as distinct vortices, very many, perhaps most, of them originate on the plains of India; especially in such cases as the succession of storms in the earlier part of January 1883, of which a brief description was given in the "Climates and Weather of India." Mr. Eliot, too, seems to hold a similar view, since he speaks sometimes of storms "forming" in Rajputana, &c., sometimes merely as "first appearing" in Sind, Rajputana, or the Punjab. But in some of these instances there is evidence that the appearance of the storm on the plains of the north-western frontier was preceded by stormy weather in Afghanistan, indicating that the disturbance had reached India from that country or Baluchistan; and Mr. Eliot distinctly identifies a storm that appeared in the Punjab on January 9, 1889, with one that had been experienced at Bushire at the head of the Persian Gulf, on the 7th and 8th.

In this matter, we must distinguish between the barometric depression, which appears like the trough of a great atmospheric wave of very great extent both in longitude and latitude, sweeping across the country from the westward, and the vortex, or in some cases vortices, which are, as a rule, merely local and subordinate features of the former. No doubt, it is the passage of one of these troughs that in all cases determines the formation of the

<sup>1</sup> One of the lowest temperatures hitherto recorded in Northern India were those observed in the first week of February 1883, four or five days after a storm which covered with snow the plain around Rawalpindi, only 1700 feet above the sea; down to a level therefore unprecedented in the meteorological annals of India. See Report on the Meteorology of India in 1883; also "Climates and Weather of India," p. 204.

storm; but, except when the advent of a vortex can be distinctly traced to the highlands of the western frontier, it seems very likely that its development and duration are in some degree influenced by the local conditions of the land surface, such as have been already noticed in the case of the Northern Punjab; and its intensity would seem to be mainly dependent on the amount of snow and rain that is precipitated.

From what has been said above, the general resemblance of the winter storms of Northern India to those of our own latitudes will be sufficiently obvious. In their eastward movements, the localization of the rainfall, the contrasted temperature conditions of the opposite quadrants, and many other particulars, we may recognize their essential identity. But certain features which are more or less blurred in our European storms, in those that we are now dealing with stand out with much clearer definition; and they seem calculated to throw not a little light on the still vexed question of storm generation, and perhaps to reconcile some of the very conflicting views that now prevail on this subject. As Mr. Lewis Morris says of the old Greek myths—

*THE MAGNETIC STORM OF FEBRUARY*  
13-14, 1892.

THE Superintendent of the U.S. Naval Observatory sends us the following records of the magnetic storm of February 13:—

"The records of this unusually severe magnetic storm are of especial interest as occurring at the same time as the fine displays of auroræ and the appearance of a large group of sun-spots.

"These fair tales which we know so beautiful  
Show only finer than our lives to-day  
Because their voice was clearer and they found  
A sacred bard to sing them"—

so may we say of these manifestations of aerial action in India. The phenomena are similar in kind to those that pass before our own eyes, but they stand out, accentuated by the circumstances of the climate and country, with a clearness and prerogative emphasis that we may seek for in vain in the confused and kaleidoscopic weather phases of these latitudes. We read their meaning almost at a glance, as we gather that of a printed page, and have not laboriously to pick out and piece together the obscure facts that express it, as with painful effort we might decipher the faded and half-concealed characters of a monkish palimpsest. And by good fortune, we have at the head of the Indian Meteorological Department an accomplished mathematician and physicist, who appreciates to the full the rich opportunities of his charge, and who knows how to marshal and interpret his facts as well as record them.

HENRY F. BLANFORD.

"The first increase in the horizontal force was followed by a rapid decrease, the force falling to much less than its usual strength, with rapid changes. Its change during the storm was 2½ per cent. of its mean strength. The vertical force decreased so much that the sensitive balanced magnet used to record it was upset at 8 p.m. of the 13th, and its further record lost.

"The auroræ were seen at Washington at about 2 a.m. and 7-30 p.m. of the 13th, the latter time being marked by an unusually disturbed condition of the magnets."

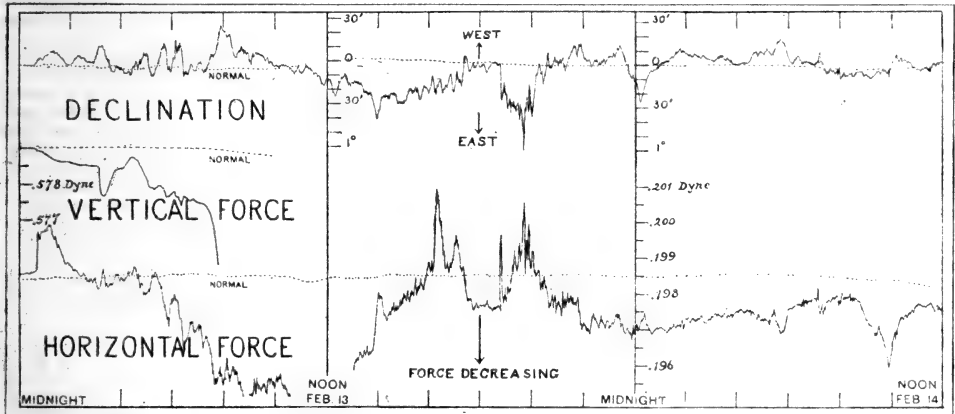

"The magnetic storm commenced suddenly at 12.40 a.m. (75th meridian time), February 13, with a movement of the north end of the declination magnet to the westward, and a rapid increase in the horizontal and decrease in the vertical components of the earth's magnetic force.

"The north end of the declination magnet remained to the westward of its normal position until 10.30 a.m., when it crossed to the eastward, all the time oscillating violently, and did not return to the normal until 8 p.m. of the 13th, after which it kept oscillating on each side of its mean position until the end of the storm. It registered a change of direction of 1½°.

*WILLIAM DITTMAR.*

ALL who take an interest in the progress of chemistry will regret the death of William Dittmar; a smaller circle feel that they have lost an invaluable friend. Born at Umstadt, near Darmstadt, April 15, 1833, he was the second son of Fritz Dittmar, then Assessor at Umstadt, afterwards Landrichter at Ulrichstein, in Ober-Hessen, where he took a part in the movements of 1848 displeasing to the Hessian Government, who removed him from office, allowing him to retire on a pension. At the age of sixteen, therefore, William became a resident in

Darmstadt, where his father spent his enforced leisure. He was apprenticed to the Hof-Apotheker in Darmstadt, and in due time passed his "Gehülfe Examen" with distinction. He had access to a good collection of books on chemistry and physics, which he eagerly read. He went as Gehülfe to Mühlhausen in Alsace, where he spent several years, and returning to Darmstadt passed the "Staats Examen" in pharmacy, passing in the first class. But the attraction of pure chemistry prevailed, and in 1857 he went to Heidelberg. Bunsen soon saw what kind of student he had got, and appointed him assistant in the laboratory. There he met Sir Henry Roscoe, who invited him to Manchester as his private assistant. On Roscoe's appointment as Professor of Chemistry in the Owens College, Dittmar went with him as assistant. In 1861 he became chief assistant in the Edinburgh University Chemical Laboratory under Prof. Sir Lyon Playfair. In 1869 he went to Bonn, where he acted first as *Privatdocent* and afterwards as Lecturer on Meteorology at the Agricultural College at Poppelsdorf. In 1872 he declined the Chair of Chemistry in the Polytechnic School at Cassel, preferring to return to Edinburgh to his old post in the University. Here he remained only a few months, accepting in 1873 the Lectureship on Practical and Technical Chemistry in the Owens College. Thence he removed to Glasgow to succeed Prof. Thorpe in the Chair of Chemistry in the Andersonian College. This office he held till his death, February 9, 1892. He died literally in harness. He lectured in the morning, but not feeling very well, went home in the middle of the day, and after a few hours' illness died at 11.30.

He was a Fellow of the Royal Society and of the Royal Society of Edinburgh. In 1887 the University of Edinburgh conferred on him the degree of Doctor of Laws. The Philosophical Society of Glasgow awarded him last year the Graham Medal for his investigation into the composition of water.

Dittmar was a man of great intellectual energy, which always took a practical turn, indeed it is rare to see a man so truly scientific in all the operations of his mind so free from speculation. Not that his imagination was unused, but so prominent before him was the practical result to be obtained, that it gave a character of reality to the whole process by which he sought to reach it.

His most important work was analytical. His great investigation into the composition of the specimens of sea-water collected by the *Challenger* Expedition is a masterpiece of judgment and skill, important not only for its results, but perhaps even more for its methods. We may mention also his determination of the atomic weight of platinum, his method for the analysis of chrome iron ore, his examination of the alkaline hydrates and carbonates, and the gravimetric determination of the composition of water. But he did not confine himself to analytical work. He published along with Kekulé a paper on oxymethylbenzoic acid, the first aromatic alcohol acid; and also while at Bonn obtained glutaric acid by the reduction of Ritthausen's glutanic acid. He did much excellent work in physical chemistry. We may mention the determination of the vapour-pressure of formate of ethyl and acetate of methyl, his work on the dissociation of sulphuric acid and on the relation of the composition of acids of constant boiling-point to the pressure under which they are distilled. He made the construction of the balance a subject of special study, and the balances constructed for him by Oertling and by Staudinger are models of convenience and accuracy.

But Dittmar was greatest as a teacher. Patient and careful, he helped his students where they needed help, and led them to think and work for themselves. He had no ambition to make his pupils analyzing machines; they had to understand all that they did. Gradually his great power as a teacher came to be appreciated, and latterly his laboratory was filled with enthusiastic pupils. Those

whom he has trained are his real works on analytical chemistry; but others can learn much of his method from his admirable treatise on qualitative analysis.

A. C. B.

#### SERENO WATSON.

THE last American mail brought the sad intelligence of the death of this indefatigable botanist, upon whom, in one sense, the mantle of Asa Gray fell barely four years ago. Early in the year he was seized with a bad attack of *grippe*, and although he rallied and was better for a time, he never recovered strength, and finally succumbed on the 9th inst., in the sixty-sixth year of his age. Of his early life we know nothing, but he appears to have published no botanical work previous to 1873, about the period that he was appointed Herbarium Assistant to Dr. A. Gray at Harvard. From that date, however, onward until within a few months of his death, he was, next to Gray, the most active writer on North American Phanerogams. Much of his work appeared originally in the Proceedings of the American Academy of Arts and Sciences, under the title of "Contributions to American Botany," numbered consecutively, the last being the eighteenth. These consist principally of monographs of North American genera and descriptions of novelties. He was also the principal author of the "Botany of California," the last volume of which appeared in 1880; and since the death of Dr. A. Gray, he in conjunction with Prof. J. M. Coulter has edited the sixth edition of the deceased author's valuable "Manual of the Northern United States." This work has been considerably decried by contemporary American botanists, because Watson did not introduce the changes in nomenclature consequent on a strict and unqualified observance of the law of priority. But in this conservatism he doubtless followed the wishes of his former master, and enjoyed the sympathies of those whose experience teaches them that it is much easier to make these changes in books than to carry them into practice. Watson had a still more important work in hand, for he had undertaken the continuation of Gray's "Synoptical Flora of North America." How far this is advanced we do not know, but it is not probable that it will see the light on the same lines as the published volumes, or as he would have continued it. Unfortunately, an exceedingly useful work, commenced during the early part of Watson's engagement at Harvard, was never completed. We allude to his "Bibliographical Index to North American Botany," which was only carried to the end of the Polypetalæ. To a great extent, Gray's "Synoptical Flora" takes its place, so far as the Gamopetalæ are concerned; but it is difficult to find one's way in the remaining groups. Though Sereno Watson was of a retiring disposition, and did not belong to the teaching body, nor take a prominent part in the gatherings of scientific men, yet the loss of him will be widely felt and deplored. He was elected a Foreign Member of the Linnean Society of London in 1890, but he was not a man who craved after honours and distinctions.

#### NOTES.

It seems almost incredible that the Treasury should think of stopping the publication of the *New Bulletin* simply because it does not quite pay its own expenses. The periodical, as our readers know, is one of high value, both from the scientific and the industrial point of view, and if the Treasury persists in the design attributed to it, something ought soon to be said on the subject in Parliament by the scientific members. The *Times* has argued strongly against the proposed step, and the view it has expressed will be shared by all who are capable of forming



an intelligent opinion on the subject. It cannot be expected that a very large number of copies of the *Bulletin* will be sold, as it is really more useful to our colonial Governments than to individuals either here or in the colonies.

THE Council of the Royal Society of New South Wales has awarded to Mr. W. T. Thiselton-Dyer the Clarke Memorial Medal, in recognition of his distinguished services in the cause of botanical science, and especially on account of his labours in connection with the development and organization of the Botanical Departments for the Colonies and India, at the Royal Gardens, Kew. The medal has been forwarded with a letter, dated December 23, 1891, in which Mr. W. H. Warren, the Honorary Secretary, says:—"The Council fully appreciates the beneficial effects which this colony (in common with the other British possessions) has already derived and will continue to derive from the foresight and scientific zeal you have displayed in the building up of the Colonial Departments of your institution; the Council is also aware of the assistance which the Department under your direction has given to institutions in Sydney, and is not unmindful of the fact that the first collections obtained by the Sydney Technological Museum were received from the Museum of the Royal Gardens, Kew. The Council trusts that you will therefore accept the medal, as a token on the part of this Society of the appreciation in which your work is held in Australia." Mr. Warren's letter, with Mr. Thiselton-Dyer's answer, is published in the new number of the *Kew Bulletin*. In a prefatory note the Director of the Royal Gardens explains that in publishing the correspondence he feels "he is only putting on record a mark of appreciation as handsome as it is spontaneous, on the part of one of the most distinguished of the colonies of the Crown, of the usefulness of the official work which the Kew establishment could alone accomplish with the continuous and loyal assistance of every member of its staff."

STUDENTS of archaeology will be glad to hear that Mr. F. C. Penrose has gone to Greece to carry on his investigation of the dates of Greek temples as derived from their orientation. He hopes to determine the orientation of many foundations not included in the list given in his recent paper on the subject. He will also verify, as far as possible, the approximate results at which he has already arrived.

ON March 28 many educational institutions in Austria and Germany will celebrate the three hundredth anniversary of the birth of Johann Amos Comenius, one of the most illustrious of pedagogues. The Austrian Government, however, has forbidden the proposed celebration in Bohemia. Comenius was by birth a Moravian. He anticipated many of the best ideas of our own time on education, and by his numerous writings and his great personal influence produced a profound impression on his contemporaries. Charles I. invited him to England to improve the organization of English schools; but the outbreak of the Civil War made it impossible for him to give effect to his ideas in this country.

PROF. GRIESBACH lately forwarded to Vienna various fossils which he had collected during his geological explorations in the Central Himalayas on behalf of the Government of India. They resemble so closely fossils found in corresponding Alpine strata, that they have excited much interest; and the Royal Imperial Academy of Science, Vienna, has determined, with the co-operation of the Indian Government, to send an exploring party to the Central Himalayas to compare their geological features with those of the Eastern Alps. The leader of the party will be Dr. Carl Diener, lecturer on geology at the University of Vienna. Dr. Diener is President of the Vienna Alpine Club, and is well known as the author of a work on the geo-

logical structure of the Western Alps. He will start for Brindisi on April 10, taking with him two Tyrol guides. The expedition will last six months.

THE anniversary meeting of the Chemical Society will be held on March 30 at 4 p.m.

DR. GEORGE BUCHANAN, F.R.S., who has long been known as one of the highest authorities on sanitary science, is about to resign the post of medical officer to the Local Government Board.

THE following are some of those who have consented to serve on the jury for the Crystal Palace Electrical Exhibition:—Prof. W. Grylls Adams, Prof. W. E. Ayrton, Mr. Shelford Bidwell, Prof. W. Crookes, Major-General Festing, Prof. George Forbes, Captain Sir Douglas Galton, Dr. J. H. Gladstone, Prof. D. E. Hughes, Mr. W. H. Preece, Prof. Silvanus Thompson.

ON Monday evening Mr. Kimber asked the Chancellor of the Exchequer why the British Government had not concurred with the other European Governments in joining the International Geodetic Bureau of Vienna. In reply, Mr. Goschen said the question of joining the reconstituted International Geodetic Bureau was raised just five years ago, the condition being an annual contribution of 2250*l.* a year for ten years, besides the expense of sending delegates to attend the meetings of the Bureau. "Our experience of the International Metric Bureau at that time," Mr. Goschen continued, "showed that the expenditure upon such undertakings tends to increase out of proportion to their actual utility, and it was considered that the practical advantages of joining the Geodetic Bureau were not sufficient to justify the guaranteeing of the sum named. So far as I am aware, the question has not been mooted since."

THE first annual meeting of the North-West of England Boulder Committee was held at the Technical School, Stockport, on the 19th inst. The year's work has been eminently practical and useful. The Committee, in addition to contributing a very large portion of the Report of the Erratic Block Committee of the British Association presented at Cardiff, have read and discussed more than forty papers and reports at their monthly meetings; these they now propose to print independently. Maps on the one-inch and six-inch scale have been acquired, partly by purchase and partly by presentation, including a valuable set from Sir A. Geikie, F.R.S., Director-General of the Geological Survey. On these good progress has been made, by a distinctive system of symbols, in showing the position and origin of the boulders over a large area. A thoroughly practical "Drift Primer" has been drawn up by the Secretary and approved by the Council of the Committee for the instruction of observers, and has circulated beyond the limits of the Committee. Boulder-forming rocks have been collected in England and Scotland, for reference purposes, and the nucleus of a Glacial Drift library formed. The Annual Report shows a large increase of members outside the original district of observation, and it was therefore decided that henceforth the title should be altered to "The Glacialists' Association," and that the rules be altered so as to include the whole of "the British Isles." The President, Mr. De Rance, and the Secretary, Mr. Percy Kendall, were re-elected, and the following Vice-Presidents were elected: Vice-Chancellor Sir Henry Bristow, Mr. Brockbank, Mr. Gray, Alderman Kay, and Dr. Ricketts, and a Council of fifteen.

AMONG the contents of the new number of the *Kew Bulletin* is an interesting account of the Spanish Broom as a fibre plant. Some time ago a French scientific journal printed a notice respecting the use of the fibre of the Spanish Broom among the peasants in the neighbourhood of Lodève, and in the remote hamlets in the mountains of Languedoc. An effort was made to secure speci-

mens of the fibre, and of articles produced from it, for the collections in the Museums of Economic Botany at Kew. It was with the utmost difficulty that specimens were obtained; but ample material for arriving at a definite conclusion with regard to the origin and character of "Genista fibre" was at last received. There is now in the Kew Museums a complete set, consisting of twigs, fibre in various stages of preparation, as well as yarns and coarse cloths. These were sent by Mr. Consul Perceval. There is also a sample of coarse sheeting received from M. Geoffroy St. Hilaire through the English Embassy at Paris. These fully illustrate the fibre industry connected with *Spartium* (*Genista*) *junceum*. "It is evident," says the *Bulletin*, "that this interesting rural industry is fast dying out in France. It may be said to exist now only in very remote hamlets in the Cevennes. The inquiries made by Kew were therefore only just in time to secure the last specimens of cloth made in the laborious fashion before the days of rapid communication and the introduction of cheap cotton and other goods."

ONE of the most interesting of recent additions to the Museums of Economic Botany at Kew has recently been received from Sir John Kirk. It consists of a large sheet of bark cloth prepared by the natives of Uganda from the inner bark of a species of *Brachystegia*, a small genus of trees belonging to the *Cesalpiniæ* sub order of the natural order *Leguminosæ*. Various details relating to the use of *Brachystegia* as a source of bark cloth are given in the current number of the *Kew Bulletin*. The same number contains sections on oil palm fibre and the sources of rubber supply.

ANYONE who may desire to devote himself to the study of Finnish archæology and folk-lore will find ample material for study in the information collected by the late Dr. H. A. Reinholm. He was chaplain of the prison, and pastor of the Lutheran congregation, at the Fortress of Sveaborg, near Helsingfors, and for many years devoted the whole of his leisure time to the amassing and arrangement of facts relating to the life of the Finnish people in past times. He died in 1883. Only a few results of his researches have been published. By far the greater part of his work is preserved in manuscript in the Historical Museum at Helsingfors. An interesting account of the labours of this indefatigable investigator is given in the current number of *Globus*.

MR. R. H. SCOTT delivered a lecture at the Royal United Institution on March 18, on a subject of much importance to meteorologists in this country, viz. "Atlantic Weather and its connection with British Weather." He pointed out that less than a quarter of a century ago, before synchronous charts were in vogue, it would have been impossible to have traced a storm across America and the Atlantic to our own coasts; but this can now be done with considerable certainty. The broad principles which govern the weather system of the Atlantic were shown on two diagrams exhibiting the mean pressure, and the regions of greatest disturbance of temperature, on the globe, in our winter. The latter chart showed that, at that season, the relatively warmest district is near Iceland; and the barometer chart showed that close to the same region the barometer is lowest. The reasons of these relations, which involve the first principles of modern weather knowledge, were fully explained. The more northern part of the Atlantic area interests us the most. The whole region from 40° to 70° N. is constantly visited by cyclonic depressions, and in order to throw some light on the origin and history of these depressions, and of the storms which they at times bring with them, various institutions have published daily maps of the weather in the Atlantic. The most complete of these maps were published by the Meteorological Office for thirteen months, commencing with August 1882. The last

twelve of these months have been carefully examined, and show no less than 264 depressions in various parts of the ocean. Of these, out of 62 which originated south of 40° N., only 16 had sufficient energy in them to cross the meridian of Greenwich, while out of 22 which originated further south only 11 crossed the Atlantic, and these were not all felt as actual storms in this country. The practical outcome of obtaining telegrams from America has not been satisfactory, but this failure has probably been mainly due to the fact that the reports "have been neither numerous nor full enough." This accurately represents the case at the present time; but we hope it is not too much to expect that, with our present knowledge of the paths taken by depressions with regard to areas of high pressure, some further advance may shortly be made in predicting storms by means of more numerous and fuller telegraphic reports both from outward and homeward bound ships.

The following are among the lecture arrangements at the Royal Institution for the period after Easter:—Prof. T. G. Bonney, two lectures on "The Sculpturing of Britain—its Later Stages" (the Tyndall Lectures); Mr. Frederick E. Ives, two lectures on "Photography in the Colours of Nature"; Prof. Dewar, four lectures on "The Chemistry of Gases"; Prof. H. Marshall Ward, three lectures on "Some Modern Discoveries in Agricultural and Forest Botany" (illustrated by lantern). The Friday evening meetings will be resumed on April 29, when a discourse will be given by Dr. William Huggins on "The New Star in Auriga"; succeeding discourses will probably be given by Captain Abney, Dr. B. W. Richardson, Mr. J. Wilson Swan, Sir James Crichton-Browne, Mr. Ludwig Mond, Prof. Dewar, and other gentlemen.

A GOOD seam of coal from 7 feet to 8 feet thick has been discovered by Mr. Hughes, of the Indian Geological Survey, on the banks of the Tenasserim River, which is navigable to that point. The Government of India has sanctioned the grant of a large concession in Mergui to Ah Kwi, a wealthy Chinese resident of the Straits, to prospect for tin. According to the Calcutta correspondent of the *Times*, this is the first attempt to encourage on a large scale the mining industry in Mergui.

MESSRS. CROSBY LOCKWOOD AND CO. have issued the fourth edition of Mr. Primrose McConnell's "Note-book of Agricultural Facts and Figures for Farmers and Farm Students." The author was originally induced to prepare the volume by noticing the great value of Molesworth's "Pocket-book of Engineering Formulæ" to engineers, and of similar books to those engaged in other professions. It occurred to him that a book compiled in the same style, and devoted to farming matters, could not fail to be useful as a ready means of reference for refreshing the memory. The success of the "Note-book" has proved that he was right. The progress of agricultural practice and science has been so rapid that it has been necessary for him to rewrite the greater part of the book, and nearly twice as much matter is given in the present edition as was contained in the earlier issues. The use of a slightly longer page and thinner paper has prevented the size of the volume from being much increased.

The Agricultural Research Association for the north-eastern counties of Scotland has issued its annual report for 1891. It includes a valuable paper on "Root Hair," in which Mr. T. Jamieson presents the results of a laborious investigation he has carried on during the past three years. He also gives some hints on permanent pasture, and brings together various items of information which are likely to be of immediate benefit to farmers.

IF we may judge from its twenty-sixth annual report, the American Society for the Prevention of Cruelty to Animals is

doing much good work. During the past year it prosecuted no fewer than 17,847 cases in the courts. Through its efforts 49,118 disabled animals were temporarily suspended from work; 34,264 horses, disabled past recovery, were humanely destroyed; 6444 disabled horses were removed from the streets in an ambulance. The number of prosecutions and other official interferences was larger than in previous years, but it does not follow that cruelty is more common than it was. The increase is due to the greater vigilance of the Society's officers.

IN A paper contributed to the current number of the Journal of the Franklin Institute, Prof. Lewis M. Haupt argues strongly in favour of the construction of a ship canal between New York and Philadelphia, connecting the Delaware and Raritan Rivers. Such a canal would, he maintained, extend the Erie Canal and its benefits to Philadelphia, and open to its manufacturers over 16,000 miles of waterways in the great basin of the Mississippi. It would reduce the distance by water to New York harbour from 240 to about 60 miles, would afford an inside and safe passage to Eastern, Sound, and Hudson River ports; would develop a large population along the entire route, and so benefit the railroads traversing the district. "In short," says Prof. Haupt, "the effect would be to reduce the rate per mile, as well as to shorten the distance between the two greatest centres of population on the American continent, or, we may say, in the world; for nowhere else on the globe is it possible by so short and inexpensive a waterway to connect such large populations and so many and valuable interests."

THE Bethlehem Iron Company, Pennsylvania, is to erect at the Chicago Exhibition a full-size model of its 125-ton steam hammer, said to be the largest in the world. It will span the main avenue of Machinery Hall, and will rise to a height of 90 feet. At the last Paris Exhibition great attention was attracted by a similar model shown by the Creusot works, but representing only a 100-ton hammer.

BARON VON MUELLER records, in the *Victorian Naturalist* for February, that, while elaborating diagnoses of new Papuan plants, he was pleasantly surprised to find among the novelties an *Aniholoma*. This genus has hitherto been supposed to be restricted to New Caledonia. The Papuan species is dedicated to Prof. van Tieghem. The denticulation of the leaves, the elongation of the setule of the anthers and the three-celled ovulary already separate *A. Tieghemi* from *A. montanum*. Among the novelties are also *Oxalis (Biophytum) albiflora*, *Sloanea Forbesii*, which approaches *S. quadrivalvis* in many respects, but is petaliferous, and *Quintinia Macgregori* is particularly remarkable.

A "TREATISE on Physical Optics," by Mr. A. B. Basset, will be issued shortly by Messrs. Deighton, Bell, and Co.

THE proper title of Mr. A. E. H. Love's work (included in our list of forthcoming scientific books last week) is "A Treatise on the Mathematical Theory of Elasticity."

MESSRS. NALDER BROS. AND CO. have issued price lists, carefully illustrated, of their electrical testing and other scientific instruments, and of their ammeters and voltmeters, resistance frames, &c.

MESSRS. DULAU AND CO. have issued Part xvii. of their "Catalogue of Zoological and Palæontological Books." It contains lists of works on Mollusca and Mollusca.

IN Mr. George S. Carr's letter on the terms "centrifugal force" and "force of inertia" (NATURE, p. 463), in the second sentence of the second paragraph, read "in every case as the reaction to the normal component of the centripetal force" (not "centrifugal").

AT the meeting of the Belgian Academy of Sciences on March 6, Prof. Spring announced that the late Prof. Stas had left, in an almost completed condition, a long and important memoir describing the results of several further stöchiometrical investigations. It is entitled "Silver," and will forthwith be edited, presumably by Dr. Spring, and published. It may be remembered that, after the publication of Prof. Stas's classical memoir upon the preparation of absolutely pure silver and the atomic weight of that metal, doubts were thrown by Prof. Dumas on the validity of the work on the ground that the silver employed was not free from occluded atmospheric gases. Moreover, Prof. Dumas expressed doubts as to the bearing of the work upon the celebrated hypothesis of Prout, according to which the atomic weights of all the other elements are supposed to be multiples of that of hydrogen. For, if silver possessed the atomic weight attributed to it by Prof. Stas, the atomic weight of oxygen became 15.96 and not the whole number 16, and consequently Prout's hypothesis in its original form would be negated. In order to set these doubts at rest, and to leave his work in a perfected condition, Prof. Stas has prepared a quantity of silver with such extreme precautions that he has succeeded in obtaining it entirely free from occluded gases, and from even the minutest traces of the materials of the vessels employed. So perfect is the purity of this silver that even when heated to the temperature of the melting-point of iridium not a trace of sodium can be detected in the spectrum of the vapour. With this silver he has repeated his former determinations of the atomic weight of the metal, and it is satisfactory to learn that the final number obtained is, as Prof. Stas himself expected it would be, identical with that formerly obtained. Hence, the objection of Prof. Dumas cannot longer be entertained, and the atomic weight of oxygen would indeed appear to be 15.96 and not 16, for the numbers obtained by Prof. Stas agree so remarkably that an error of four-hundredths of a unit would apparently be out of the question. In addition to this important memoir, Prof. Stas has also left the data of a series of twelve separate determinations of the stöchiometric relation of silver to potassium chloride, the materials for which were the pure silver just described, and a specimen of potassium chloride, also prepared with a care and precaution quite in keeping with the rest of the work of the great analyst. The results of these determinations are described by Prof. Spring as agreeing in a most wonderful manner, and will afford another valuable base to which the atomic weights of many other elements may be referred. Besides these two memoirs, a third is mentioned by Prof. Spring, relating to the spectra of several metals which Prof. Stas has obtained in the purest state in which these metals have ever probably been seen. The whole of these memoirs, consisting of about fifteen hundred pages of manuscript, it is intended to publish forthwith in three separate treatises.

THE additions to the Zoological Society's Gardens during the past week include a Ring-necked Parrakeet (*Palaornis torquatus* ♂) from India, presented by Mr. George H. Whitaker; a Grey-breasted Parrakeet (*Bolborhynchus monachus*) from Monte Video, presented by Miss Mildred Whitaker; a Roseate Cockatoo (*Cacatua roseicapilla*) from Australia, presented by Mr. J. S. Gibbons; a Numeg Fruit Pigeon (*Carpophaga bicolor*) from the Torres Straits, presented by Mrs. Fitzgerald; two Pike (*Esox lucius*) from British Fresh Waters, presented by Mr. P. F. Coggin; a Manchurian Crane (*Grus viridirostris*) from North China, deposited.

#### OUR ASTRONOMICAL COLUMN.

FUZZINESS OF SOME VARIABLE STARS.—Mr. Cuthbert G. Peek has, during the last six years, used his 6½-inch achromatic for the investigation of the light-curves of variable stars. In

this month's *Knowledge* he describes some observations of changes in appearance of a few variable stars at different epochs. Three variables—*T* Cassiopeie, *R* Cassiopeie, and *S* Herculis—have been frequently observed as (*a*) remarkably well defined, almost planetary, disks; (*b*) well-defined stars, surrounded by a more or less dense, ruddy atmosphere; (*c*) large, woolly, ill-defined images, resembling a small but bright planetary nebula; (*d*) at minimum, in place of the variable, a slight bluish nebulosity. The changes appear to be real, for stars near the places of the variables have been seen clear and sharp when the haziness of the variables was unmistakable. Other stars with regard to which Mr. Peck has made similar observations are *S* Cassiopeie, *R* Tauri, *R* Aurigæ, *V* Cancri, *R* Ursæ Majoris, *S* Ursæ Majoris, *R* Camelopardi, *R* Boötis, *S* Coronæ, *R* Aquilæ, and *S* Cephei.

**ASTRONOMICAL POSSIBILITIES AT CONSIDERABLE ALTITUDES.**—Prof. Pickering, in No. 3079 of the *Astronomische Nachrichten*, relates some interesting facts in an article on "Astronomical Possibilities at Considerable Altitudes." They are gleaned from observations made at the Boyden Station of the Harvard College Observatory, which is situated two miles from the city of Arequipa, Peru, in latitude  $16^{\circ} 24'$  S., and longitude  $4h. 45m. 30s. W.$  of Greenwich, and at an altitude of 8060 feet above sea-level. The air there is so clear and steady that 6.5 magnitude stars are picked out by the naked eye with great ease, and when the moon is not too bright, the eleven Pleiads can always be counted. The nebula in Andromeda forms also a very conspicuous object, "appearing larger than the moon," while, in the 13-inch Clark refractor, "the whole photographic region of the great Orion nebula, first shown in the Harvard photographs of 1887, is clearly visible to the eye," rendering it the "most splendid object in the stellar universe." The steadiness of the atmosphere is also very much remarked there, so much so that a scale of steadiness has been adopted. Some of the brightest stars have been noticed to have as many as six complete diffraction rings round them; while around these, when the seeing was denominated as "perfect," twelve rings have been counted. "Boiling" was also found to be sometimes completely eliminated, for, in observing bodies of the solar system with a 13-inch and a power of 400, "it was frequently impossible to detect any wavering of the edges of the disk."

The conclusion that Prof. Pickering comes to with regard to the position of future Observatories is that "moderate altitude is a most desirable qualification," while "for transparent skies one must approach the tropics, and for steady seeing one must have an extremely dry climate."

**INCREASE OF THE EARTH'S SHADOW DURING LUNAR ECLIPSES.**—In a memoir with the title "Die Vergrößerung des Erdschattens bei Mondfinsternissen" (*Abhandlungen der math. phys. Classe der k. Sächsischen Ges. d. Wissenschaften*, vol. xvii., Leipzig, 1891), Dr. Hartmann published the results of an investigation into the amount by which the earth's atmosphere increases the diameter of the section of the shadow during a lunar eclipse. An abstract of the memoir appears in the annual report of the Royal Astronomical Society, which has just been issued. Since the time of Tobias Mayer (1750) the coefficient  $\frac{1}{\sigma_0}$  has been assumed to represent this increase, although nothing is known as to the manner in which this quantity was determined. Dr. Hartmann has reduced all the observations of lunar eclipses observed independently by several astronomers during this century, and has deduced the increase of the diameter of the shadow from them. The result of a comprehensive discussion of 2920 observations of the contact of the shadow with well-defined lunar formations is, that the increase of the semi-diameter of the shadow is  $48'' 62'$  for mean lunar parallax. This corresponds to a coefficient of increase =  $\frac{1}{50.79}$ . The [result may perhaps be changed  $2''$  or  $3''$  by a discussion of new observations, but not more, so it seems desirable that the value of  $\frac{1}{\sigma_0}$  should be used, when required, instead of Mayer's value of  $\frac{1}{\sigma_0}$ .

#### THE NEW STAR IN AURIGA.

THE new star is rapidly getting more and more difficult of observation in consequence of its waning light. There is very little change in its spectrum, and what change there is not in the direction recorded of Nova Cygni, so it seems pretty

clear that the new body was not a hitherto unobserved nebula to begin with.

The *Astronomische Nachrichten*, No. 3079, contains (at p. 109) the following communication from Mr. H. C. Vogel, Director of the Astro-physical Observatory at Potsdam, dated February 29:—

"Although the spectroscopic observations of the Nova in Auriga are not yet concluded—since the star will probably continue visible for some time—I consider it of importance, in the interest of the subject, to communicate my observations made hitherto, and the conclusions drawn therefrom, even though the latter should not in the future be confirmed in all points.

"Concerning, first, the direct spectroscopic observations, I have, on February 20, observed the Nova with a compound spectroscope of a dispersion sufficient just to show the nickel line between the D lines. The hydrogen lines C, F, and H $\gamma$  appeared bright. Their identification was easy by means of a hydrogen tube in front of the slit. These three lines did not exactly coincide with the lines of the comparison spectrum, but were displaced considerably towards the red, without, however, separating completely from the artificial lines, since they were very broad. The continuous spectrum appeared faint, owing to the comparatively high dispersion; and with certainty only the dark broad F line was recognizable, situate towards the more refrangible side, distinctly separated from the bright line in the spectrum.

"Between C and F, a large number of bright lines could be seen, but most of them were too faint to be fixed with certainty. In the case of two brighter lines near F, myself and Mr. Frost, who assisted in the observations, succeeded in making very certain wave-length determinations; we found  $492.5 \mu\mu$  for the fainter of the two lines, which appeared broad and fuzzy on both edges, and  $501.6 \mu\mu$  for the brighter line. The limit of error is to be taken at about  $\pm 3 \mu\mu$ , and it results from the observation with certainty that the brighter line is *not* identical with the double line of the air spectrum or with the brightest line of the nebula, and still less the other with the second nebula line. From Young's list of lines most frequent in the chromosphere, it follows that near F only the two groups of lines, 501.87, 501.59, and 493.44, 492.43, 492.24, 491.92 frequently appear bright. There is no doubt that both lines in the spectrum of the Nova are chromosphere lines, and this result appears to me of great importance, in so far as it is made probable that the line observed in Nova Cygni (1876)—W.L.  $500 \mu\mu \pm 1 \mu\mu$ —which, during the gradual fading of the star, alone remained, was a chromosphere line, and not the nebula line.

"Further, both myself and Mr. Frost saw probably the magnesium lines, certainly the sodium lines bright, as also two lines between  $\beta$  and D, one of which probably was the well-known chromosphere line W.L. 531.72, also observed in Nova Cygni. By direct comparison with the hydrocarbon spectrum, the brightest band of which nearly coincides with the  $\beta$  group, and with the sodium flame,  $\beta$  and D were identified. Mr. Frost could see a displacement of the D lines in the star spectrum with respect to the comparison spectrum. There was no indication of hydrocarbon bands in the spectrum of the Nova.

"Up to the present eleven mostly very good spectrographic photographs have been taken; they were obtained by means of a small spectrograph connected to the photographic refractor of 34 cm. aperture. The dispersion is only small, but in the small spectrum of 10 mm. length, extending from F to H, much detail is discernible. The illuminating power of the apparatus is so great, in spite of the narrow slit employed, that even now an exposure of 40 minutes is sufficient to obtain an image suitable for measurement. The bright hydrogen lines F, H $\gamma$ ,  $\delta$ , H, and the calcium line H $\beta$ , are very broad; and, as already announced, the corresponding dark lines of a second spectrum are displaced with respect to the bright lines towards the violet, and in spite of the breadth of the latter, are almost entirely separated. There are still some of the hydrogen lines in the ultra-violet visible, but they are too faint for any approximately certain observation.

"In the last few days the spectrum has changed, inasmuch as in the broad bright lines H $\gamma$ ,  $\delta$ , H, and H $\beta$  (F is only traced on plates which are over-exposed for the middle of the photographic spectrum), two maxima of intensity are plainly discernible, and, as in each of the corresponding dark lines, a narrow bright line has appeared. From the measurements, a connection between these and the hydrogen lines appears beyond doubt, and it is

not improbable that these linear brightenings in the broad dark lines indicate eruptions of gases from the interior of the body possessing the continuous spectrum with the dark absorption lines. Such brightenings are occasionally seen in the spectra of sun-spots. On this supposition, the fine bright lines would indicate very nearly the middle of the dark lines.

"The appearance of two maxima of intensity in the broad bright lines admits of the conclusion that two bodies with different motions possess spectra with bright lines, and that therefore the spectrum of the Nova consists of at least three spectra superposed, from the measurement of which, in connection with the comparison spectra of  $\beta$  Aurigæ or  $\beta$  Tauri on the same plate, the relative motions of the three supposed bodies, as well as their motions with respect to the earth, can be determined. Denoting the body with the dark-line spectrum by  $a$ , the two others with bright-line spectra by  $b$  and  $c$ , measurements by myself and Dr. Scheiner have given the following results :

$$a - \frac{1}{2}(b + c) = 120 \text{ miles,}^1$$

$$b - c = 70 \text{ miles.}$$

and further with respect to the earth—

$$a = -90 \text{ miles, } b = -5, c = +65 \text{ miles.}$$

"This result is still very uncertain, and must be regarded as quite preliminary, for it is evident that with the small size of the spectra the accuracy cannot be pushed very far—a displacement of 0.1 mm. corresponds, for instance, to a motion of 8 to 12 miles, according to the situation of the line in the spectrum—and that the size of the silver grain in the photographs can exert a very marked influence on the measurements.

"In the photographic spectrum of the Nova, besides the broad lines mentioned, several more bright and mostly very broad lines can be seen, whose wave-lengths I intend to communicate later on."

Prof. Pickering communicates some valuable information to the same number of the *Astronomische Nachrichten* with reference to the visibility of the Nova before its discovery by Dr. Anderson. In eighteen photographs of this region, which were taken by the 8-inch photographic telescopes between the dates November 3, 1885, and November 2, 1891, no star in the Nova's place was visible, but in those taken from December 16, 1891, to January 31, 1891, there was a star of the fifth magnitude recorded. In another series of plates taken with the transit photometer, no record of the new star up to December 1, 1891, was obtained, although  $\chi$  Aurigæ (mag. 5.0 m.) was always visible, but the plates taken on the nights of December 10, 1891, and ending January 20, 1892, indicated clearly the position of the new star.

Careful examination has been made on all the above-mentioned plates, and the following extract shows the series of magnitudes which have been deduced from the measurements:—

"It appears that the star was fainter than the eleventh magnitude on November 2, 1891, than the sixth magnitude on December 1, and that it was increasing rapidly on December 10. A graphical construction indicates that it had probably attained the seventh magnitude within a day or two of December 2, and the sixth magnitude December 7. The brightness increased rapidly until December 18, attaining its maximum about December 20, when its magnitude was 4.4 m. It then began to decrease slowly, with slight fluctuations, until January 20, when it was slightly below the fifth magnitude."

From this it will be seen that two months' observations have been lost, owing to its late discovery.

### ABERRATION.<sup>2</sup>

UNDER this head may conveniently be considered not only the apparent displacement of the stars discovered by Bradley, but other kindred phenomena dependent upon the velocity of light bearing but a finite ratio to that of the earth in its orbit round the sun, and to other astronomical velocities.

The explanation of stellar aberration, as usually given,

<sup>1</sup> = about 540 English miles.—Tr.

<sup>2</sup> This paper was written in 1887, when I was occupied with my article upon "Wave Theory" for the "Encyclopædia Britannica," and at a time when a more extensive treatment was contemplated than was afterwards found practicable. Friends on whom I can rely are of opinion that its publication may be useful; and, as I am not able to give it a complete revision, I prefer to let it stand under its original date, merely warning the reader that very important work has since been published by Michelson.—January 1892.

proceeds rather upon the basis of the corpuscular than of the wave theory. In order to adapt it to the principles of the latter theory, Fresnel found it necessary to follow Young in assuming that the æther in any vacuum space connected with the earth (and therefore practically in the atmosphere) is undisturbed by the earth's motion of 19 miles per second. Consider for simplicity the case in which the direction of the star is at right angles to that of the earth's motion, and replace the telescope, which would be used in practice, by a pair of perforated screens, on which the light falls perpendicularly. We may further imagine the luminous disturbance to consist of a single plane pulse. When this reaches the anterior screen, so much of it as coincides with the momentary position of the aperture is transmitted, and the remainder is stopped. The part transmitted proceeds upon its course through the æther independently of the motion of the screens. In order, therefore, that the pulse may be transmitted by the aperture in the posterior screen, it is evident that the line joining the centres of the apertures must not be perpendicular to the screens and to the wave front, as would have been necessary in the case of rest. For in consequence of the motion of the posterior screen in its own plane the aperture will be carried forward during the time of passage of the light. By the amount of this motion the second aperture must be drawn backwards, in order that it may be in the place required when the light reaches it. If the velocity of light be  $V$ , and that of the earth be  $v$ , the line of apertures, giving the apparent direction of the star, must be directed forwards through an angle equal to  $v/V$ . More generally, if the angle between the star and the point of the heavens towards which the earth is moving be  $\alpha$ , there will be an apparent displacement towards the latter point, expressed by  $\sin \alpha \cdot v/V$ , and independent of the position upon the earth's surface where the observation is made. The ratio  $v/V$  is about  $\frac{1}{17133}$ .

The aperture in the anterior screen corresponds to the object-glass of the telescope with which the observation would actually be made, and which is necessary in order to produce agreement of phase of the various elementary waves at a moderately distant focal point. The introduction of a refracting medium would complicate the problem, and is not really necessary for our present purpose. As has been shown (*Philosophical Magazine*, March 1881, "On Images formed without Reflection or Refraction"), the only use of an object-glass is to shorten the focal length. Our imaginary screens may be as far apart as we please, and if the distance is sufficient, the definition, and consequently the accuracy of alignment, is as great as could be attained with the most perfect telescope whose aperture is equal to that in the anterior screen.

It appears, then, that stellar aberration in itself need present no particular difficulty on the wave theory, unless the hypothesis of a quiescent æther at the earth's surface be regarded as such. But there are a variety of allied phenomena, mostly of a negative kind, which require consideration before any judgment can be formed as to the degree of success with which the wave theory meets the demands made upon it. In the first place, the question arises whether terrestrial optical phenomena could remain unaffected by the supposed immense relative motion of our instruments and of the æther; whether reflection, diffraction, and refraction, as ordinarily observed by us, could be independent of the direction of the rays relatively to the earth's motion. It may be stated at once that no such influence has been detected, even in experiments carefully designed with this object in view.

Another class of experiments, with the results of which theory must be harmonized, are those of Fizeau and Michelson upon the velocity of light in ponderable refracting media which have a rapid motion (relatively to the instruments and other surrounding bodies) in the direction of propagation, or in the opposite direction. These very important researches have proved that in the case of water the velocity of the ponderable medium is not without effect; but that the increment or decrement of the velocity of propagation is very decidedly less than the velocity of the water. On the other hand, the motion of air, even at high velocities, has no perceptible influence upon the propagation of light through it.

Again, it has been found by Airy,<sup>1</sup> as the result of an experiment originally suggested by Boscovich, that the constant of stellar aberration is the same, whether determined by means of a telescope of the ordinary kind, or by one of which the tube is filled with water. It is clear that, according to Fresnel's views

<sup>1</sup> Proc. Roy. Soc., xx., 1872, p. 35; xxi., 1873, p. 121.

of the condition of the æther at the earth's surface, this agreement must involve some particular supposition as to the propagation of light in moving refracting media.

The theory of these phenomena must evidently turn upon the question whether the æther at the earth's surface is at rest, absolutely, or relatively to the earth; and this fundamental question has not yet received a certain answer. The independence of terrestrial optical phenomena of the earth's motion in its orbit is, of course, more easily explained upon the latter alternative; or rather no explanation is required. But in that case the difficulty is thrown upon stellar aberration, which follows a more simple law than we should expect to apply in the case of an æther disturbed by the passage of a body in its neighbourhood. Prof. Stokes has, indeed, attempted a theory on these lines,<sup>2</sup> by supposing the ætherial motion to be what is called in hydrodynamics irrotational. In strictness there is, however, no such motion possible, subject to the condition of vanishing absolutely at a great distance, and relatively at the earth's surface; and it does not appear that the objection thus arising can be satisfactorily met.

If we start from the experimental facts which have the most direct bearing upon the question under discussion, we are led to regard Fresnel's views (doubtless in some generalized form) as the more plausible. From the results of Fizeau and Michelson relative to air, we may conclude with tolerable confidence that a small mass of ponderable matter, of very low refracting power, moving in space, would not appreciably carry the æther with it. The extension of the argument to a body as large as the earth is not unnatural, though it involves certainly an element of hypothesis. In like manner, if the globe were of water, we should expect the æther to be carried forward, but not to the full amount. The simple supposition open to us is that, in any kind of ponderable matter, forming part of a complex mass, the æther is carried forward with a velocity dependent upon the local refracting power, but independent of the refracting power and velocity of other parts of the mass. In the earth's atmosphere, where the refracting power is negligible, the æther would be sensibly undisturbed.

If we agree to adopt this point of view provisionally, we have next to consider the relation between the velocity of luminous propagation in moving ponderable matter and the refractive index. The character of this relation was discovered by Fresnel, whose argument may be thrown into the following form.

Consider the behaviour of the æther when a plate of ponderable matter (index =  $\mu$ ) is carried forward through vacuum with velocity  $v$  in a direction perpendicular to its plane. If  $D$  be the density of the æther in vacuum, and  $D_1$  the density in the refracting medium, then, according to Fresnel's views as to the cause of refraction,  $D_1 = \mu^2 D$ . The æther is thus condensed as the plate reaches it; and if we assume that the whole quantity of æther is invariable, this consideration leads to the law giving the velocity ( $xv$ ) with which the denser æther within the plate must be supposed to be carried forward. For conceive two ideal planes, one in the plate and one in the anterior vacuum region, to move forward with velocity  $v$ . The whole amount of æther between the planes must remain unchanged. Now, the quantity entering (per unit area and time) is  $Dv$ , and the quantity leaving is  $D_1(v - xv)$ . Hence,

$$x = 1 - \mu^{-2},$$

so that the velocity with which the æther in the plate is carried forward is  $v(1 - \mu^{-2})$ , tending to vanish as  $\mu$  approaches unity. If  $V$  be the velocity of light in vacuum, and  $V/\mu$  the velocity in the medium at rest, then the absolute velocity of light in the moving medium is

$$V/\mu \pm v(1 - \mu^{-2}) \dots \dots \dots (1)$$

Whatever may be thought of the means by which it is obtained, it is not a little remarkable that this formula, and no other, is consistent with the facts of terrestrial refraction, and no other, is consistent with the facts of terrestrial refraction, and no other, is consistent with the facts of terrestrial refraction. It is not probable that the æther, in moving refracting bodies, can properly be regarded as itself in motion; but if we knew more about the matter we might come to see that the objection is verbal rather than real. Perhaps the following illustration may assist the imagination. Compare the æther in vacuum to a stretched string, the transverse vibrations of which represent

light. If the string is loaded, the velocity of propagation of waves is diminished. This represents the passage of light through stationary refracting matter. If now the loads be imagined to run along the string with a velocity not insensible in comparison with that of waves, the velocity of the latter is modified. The substitution of a membrane for a string will allow of a still closer parallel. It appears that the suggested model would lead to a somewhat different law of velocity from that of Fresnel; but in bringing it forward the object is merely to show that we need not interpret Fresnel's language too literally.

We will now consider a few examples of the application of the law of velocity in a moving medium; and first to the experiment of Boscowich, in which stellar aberration is observed with a telescope filled with water. We have only to suppose the space between the two screens of our former explanation to be occupied by water, which is at rest relatively to the screens. In consequence of the movement of the water, the wave, after traversing the first aperture, is carried laterally with the velocity  $v(1 - \mu^{-2})$ , and this is to be subtracted from the actual velocity  $v$  of the aperture in the posterior screen. The difference is  $\mu^{-2}v$ . The ratio of this to the velocity of light in water ( $V/\mu$ ) gives the angular displacement of the second aperture necessary to compensate for the motion. We thus obtain  $\mu^{-1}v/V$ . This angle, being measured in water, corresponds to  $v/V$  in air; so that the result of the motion is to make the star appear as if it were in advance of its real place by the angle  $v/V$ , precisely as would have happened had the telescope contained air or vacuum instead of water.

We will now calculate the effect of the motion of a plate perpendicular to its own plane upon the retardation of luminous waves moving in the same (or in the opposite) direction. The velocity of the plate is  $v$ , its index is  $\mu$ , and its thickness is  $d$ . Denoting, as before, the velocity of the æther within the plate by  $xv$ , and supposing, in the first place, that the signs of  $v$  and  $V$  are the same, we have, for the absolute velocity of the wave in the plate,

$$V/\mu + xv.$$

We have now to express the time ( $t$ ) occupied by the wave in traversing the plate. This is not to be found by simply dividing  $d$  by the above written velocity; for during the time  $t$  the anterior face of the plate (which the wave reaches last) is carried forward through the distance  $vt$ . Thus, to determine  $t$  we have

$$(V/\mu + xv)t = d + vt,$$

whence

$$\frac{Vt}{d} = \frac{\mu}{1 + (x-1)\mu v/V} \dots \dots \dots (2)$$

The time,  $t_0$ , which would have been occupied in traversing the same distance ( $d + vt$ ), had the plate been away, is given by

$$Vt_0 = d + vt;$$

so that

$$\frac{Vt_0}{d} = 1 + \frac{\mu v/V}{1 + (x-1)\mu v/V} \dots \dots \dots (3)$$

Thus

$$\frac{V(t - t_0)}{d} = \frac{\mu(1 - v/V)}{1 + (x-1)\mu v/V} - 1 \dots \dots \dots (4)$$

Substituting in this Fresnel's value of  $x$ , viz.  $(1 - \mu^{-2})$ , and neglecting as insensible the square of  $v/V$ , we find

$$V(t - t_0) = (\mu - 1)d(1 - v/V) \dots \dots \dots (5)$$

If we suppose that part of the original wave traverses the plate, and that part passes alongside, (5) gives the relative retardation—that is, the distance between the wave fronts which were originally in one plane. It would appear at first sight that this result would give us the means of rendering  $v$  evident. For the retardation, depending upon the sign of  $v/V$ , will be altered when the direction of the light is reversed, and this we have it in our power to bring about by simply turning our apparatus through 180°. A more careful examination will, however, lead us to a different conclusion.

The most obvious way of examining the retardation would be to use homogeneous light, and, by producing regular interference of the two portions, to observe the position of the fringes, and any displacement that might result from a shift of the apparatus relatively to the direction of the earth's motion. But if we employ for this purpose a terrestrial flame, e.g. that of a Bunsen's burner containing sodium, we have to take into

<sup>1</sup> An accusation of crudeness might fairly be brought against this phraseology; but an attempt to express the argument in more general language would probably fail, and would in any case be tedious.  
<sup>2</sup> *Phil. Mag.*, xxviii., 1846, p. 76; xxix., 1846, p. 6.

account the fact that the source is itself in motion. For it is evident that the waves which pass in a given time through any point towards which the source is moving are more numerous than had the source been at rest, and that the wave-lengths are correspondingly shortened. If  $v$  be the velocity of the source, the wave-length is changed from  $\lambda$  to  $\lambda(1 - v/V)$ . At a point behind, from which the source is retreating, the wave-length is  $\lambda(1 + v/V)$ . We shall have occasion to refer again to this principle, named after Döpler, as applied by Huggins and others to the investigation of the motion of the heavenly bodies in the line of sight.

Referring now to (5), we see that, although the absolute retardation is affected by  $v$ , yet that the retardation as measured in wave-lengths remains unaffected. If, then, there be, in the absence of  $v$ , an agreement of phase between the two interfering beams, the introduction of  $v$  will cause no disturbance. Consequently no shifting of the interference bands is to be expected when the apparatus is turned so that the direction of propagation makes in succession all possible angles with that of the earth's motion.

The experiment has been modified by Hoek,<sup>1</sup> who so arranged matters as to eliminate the part of the retardation independent of  $v$ . As before, of two parallel beams A and B, one, A, passes through a plate of refracting medium; the other, B, through air. The beams are then collected by a lens, at the principal focus of which is placed a mirror. After reflection by this mirror, the beams exchange paths, B returning through the plate, and A through air. Apart, therefore, from a possible effect of the motion, there would be complete compensation and no final difference of path. As to the effect of the motion, it would appear at first sight that it ought to be sensible. During the first passage, A is (on account of  $v$ ) accelerated; on the return, B is retarded; and thus we might expect, upon the whole, a relative acceleration of A equal to  $(\mu - 1)d \cdot 2v/V$ . But here, again, we have to consider the fact that another part of the apparatus, viz. the mirror, partakes in the motion. In the act of reflection the original retardation of A is increased by twice the distance through which the mirror retreats in the interval between the arrival of the two waves. This distance is (with sufficient approximation)  $(\mu - 1)d \cdot v/V$ ; so that the influence of the movement of the mirror just compensates the acceleration of A which would have resulted in the case of a fixed mirror. On the whole, then, and so long as the square of  $v/V$  may be neglected, no displacement of fringes is to be expected when the apparatus is turned. The fact that no displacement was observed by Hoek, nor in an analogous experiment by Mascart,<sup>2</sup> proves that if the stationary condition of the æther in terrestrial vacuum spaces be admitted, we are driven to accept Fresnel's law of the rate of propagation in moving refracting media.

What is virtually another form of the same experiment was tried by Maxwell,<sup>3</sup> with like negative results. In this case, prisms were used instead of plates; and the effect if existent, would have shown itself by a displacement of the image of a spider-line when the instrument was turned into various azimuths.

On the basis of Fresnel's views it may, in fact, be proved generally that, so far as the first power of  $v/V$  is concerned, the earth's motion would not reveal itself in any phenomenon of terrestrial refraction, diffraction, or ordinary refraction. The more important special cases were examined by Fresnel himself, and the demonstration has been completed by Stokes.<sup>4</sup> Space will not allow of the reproduction of these investigations here, and this is the less necessary, as the experiment of Hoek, already examined, seems to raise the principal question at issue in the most direct manner.

Another point remains to be touched upon. We have hitherto neglected dispersion, treating  $\mu$  as constant. In stationary dispersing media,  $\mu$  may be regarded indifferently as a function of the wave-length or of the periodic time. When, however, the medium is in motion, the distinction acquires significance; and the question arises, What value of  $\mu$  are we to understand in the principal term  $V/\mu$  of (1)? Mascart points out that the entirely negative results of such experiments as those above described indicate that, in spite of the difference of wave-length

due to the motion, we must take the same value of  $\mu$  as if the medium and the source had been at rest, or that  $\mu$  is to be regarded as a function of the period.

Mascart has experimented also upon the influence of the earth's motion upon double refraction, with results which are entirely negative. The theoretical interpretation must remain somewhat ambiguous, so long as we remain in ignorance of the mechanical cause of double refraction.

Reference has already been made to the important experiments by Fizeau and by Michelson upon the velocity of light in moving media. The method, in its main features, is due to the former,<sup>5</sup> and is very ingeniously contrived for its purpose. Light issuing from a slit is rendered parallel by a collimating lens, and is then divided into two portions, which traverse tubes containing running water. After passing the tubes, the light falls upon a focussing lens and mirror (as in Hoek's experiment), the effect of which is to interchange the paths. Both rays traverse both tubes; and, consequently, when ultimately brought together, they are in a condition to produce interference bands. If now the water is allowed to flow through the tubes in opposite directions, one ray propagates itself throughout with the motion of the water, and the other against the motion of the water; and thus, if the motion has any effect upon the velocity of light, a shift of the bands is to be expected. This shift may be doubled by reversing the flow of water in the tubes.

Fizeau's investigation has recently been repeated in an improved form by Michelson.<sup>6</sup>

"Light from a source at  $a$  falls on a half-silvered surface,  $b$ , where it divides; its one part following the path  $bcdedfbg$ , and the other the path  $bfedcbg$ . This arrangement has

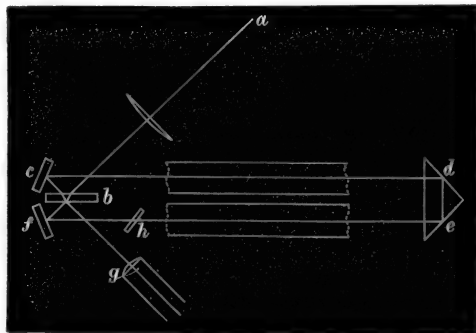

the following advantages: (1) it permits the use of an extended source of light, as a gas flame; (2) it allows any distance between the tubes which may be desired; (3) it was tried by a preliminary experiment, by placing an inclined plate of glass at  $h$ . The only effect was either to alter the width of the fringes, or to alter their inclination; but in no case was the centre of the central white fringe affected. Even holding a lighted match in the path had no effect on this point.

"The tubes containing the fluid were of brass, 28 mm. internal diameter; and in the first series of experiments, a little over 3 metres in length, and in the second series a little more than 6 metres."

Even with the longer tubes and the full velocity (about 8 metres per second) the displacement on reversal amounted to less than the width of a fringe. Nevertheless, fairly concordant results were arrived at; and they showed that the fraction ( $x$ ) of the velocity of the water ( $v$ ) by which the velocity of light is altered is  $\cdot 434$ , with a possible error of  $\pm \cdot 02$ . The numerical value of the theoretical expression is

$$x = 1 - \mu^{-2} = \cdot 437,$$

in very close accordance.

"The experiment was also tried with air moving with a velocity of 25 metres per second. The displacement was about  $\cdot 01$  of a fringe; a quantity smaller than the probable error of

<sup>1</sup> Ann. de Chimie, III. lvii. (1850).

<sup>2</sup> American Journal, vol. xxxi. p. 377 (1886).

<sup>3</sup> Archives Néerlandaises, t. iii. p. 180 (1868); t. iv. p. 443 (1869).

<sup>4</sup> Ann. de l'École Normale, t. iii. (1874).

<sup>5</sup> Phil. Trans., 1868, p. 532.

<sup>6</sup> Phil. Mag., xxviii. p. 76 (1846). See also Mascart, Ann. de l'École Norm., t. i. (1872), t. iii. (1874), and Verdet, "Euvres," t. iv., deuxième partie.

observation. The value calculated from  $(1 - \mu^{-2})$  would be '0036."

We have seen that, so far as the first power of  $v/V$  is concerned, Fresnel's theory agrees with all the facts of the case. The question whether it is possible to contrive an experiment in which  $v^2/V^2$  shall be sensible, has been considered by Michelson,<sup>1</sup> who, having arrived at an affirmative conclusion, proceeded to attack this very difficult experimental problem. In Michelson's apparatus interference is brought about between two rays, coming of course originally from the same source, one of which has traversed to and fro a distance,  $D$ , parallel to the earth's motion, and the other a like distance in the perpendicular direction. The phase of the latter ray is considered by Michelson to be unaffected by the earth's motion. As to the former, it is retarded by the amount

$$\frac{D}{V-v} + \frac{D}{V+v} - \frac{2D}{V} = \frac{2D}{V} \cdot \frac{v^2}{V^2}$$

or, reckoned in distance at velocity  $V$ ,

$$2(D)^2/V^2 \dots \dots \dots (6)$$

"Considering only the velocity of the earth in its orbit, the ratio  $v/V = 10^{-4}$  approximately, and  $v^2/V^2 = 10^{-8}$ . If  $D = 1200$  mm., or, in wave-lengths of yellow light, 2,000,000, then in terms of the same unit,  $2D^2/V^2 = \cdot 04$ .

"If, therefore, an apparatus is so constructed as to permit two pencils of light, which have travelled over paths at right angles to each other to interfere, the pencil which has travelled in the direction of the earth's motion, will in reality travel '04 of a wave-length further than it would have done were the earth at rest. The other pencil, being at right angles to the motion, would not be affected.

"If now the apparatus be revolved through  $90^\circ$ , so that the second pencil is brought into the direction of the earth's motion, its path will be lengthened '04 wave-length. The total change in the position of the interference bands would be '08 of the distance between the bands, a quantity easily measurable."

In the actual experiment, the earth's velocity was not available to the full extent, and the displacement to be expected on this account was reduced to '048; but Michelson considers that some addition to it should be made on account of the motion of the solar system as a whole. The displacement actually found was '022; and when the apparatus was employed in such azimuths that the rotation should have had no effect in any case, '034. These results are very small, and Michelson gives reasons for regarding them as partially systematic errors of experiment. He concludes that there is no real displacement of the bands, and that the hypothesis of a stationary æther is thus shown to be inconsistent with fact.

It has, however, been recently pointed out by Lorentz<sup>2</sup> that Michelson has over-estimated the effect to be expected according to Fresnel's views. The ray which travels perpendicularly to the earth's motion is not unaffected thereby, but is retarded to the amount represented by  $Dv^2/V^2$ . The outstanding relative retardation is thus only  $Dv^2/V^2$ , instead of the double of that quantity. Accepting this correction, we have to expect, according to Fresnel's views, a shift of only '024 of a band in Michelson's experiment.

Under these circumstances Michelson's results can hardly be regarded as weighing heavily in the scale. It is much to be wished that the experiment should be repeated with such improvements as experience suggests. In observations spread over a year, the effects, if any, due to the earth's motion in its orbit, and to that of the solar system through space, would be separated.

On the whole, Fresnel's hypothesis of a stationary æther appears to be at the present time the more probable; but the question must be considered to be an open one. Further evidence would be most important; but it is difficult to see from what quarter anything essentially new can be expected. It might be worth while for astronomers to inquire whether it is really true, as is generally assumed, that stellar aberration is independent of the position upon the earth's surface from which the observation is made. Another question that might, perhaps, be submitted with advantage to an experimental examination is whether the propagation of light in air is affected by the rapid

motion of heavy masses parallel to, and in the immediate neighbourhood of, the ray.

If we once admit the principle that, whatever the explanation may be, no ordinary terrestrial observation is affected by the earth's motion, it is easy to give an account of what must happen when the light comes from an external source which may have a motion in the line of sight. Imagine, for example, a spectroscopic examination of a soda flame situated on a star and vibrating in identical periods with those of terrestrial soda flames. In accordance with Doppler's principle, the wave-lengths are altered by a relative motion in the line of sight, and the fact may be rendered evident by a comparison between the spectra of the star and of the terrestrial flame, held so as to be seen in the same direction. The simplest case is when the flame is entirely external to the apparatus, so that both lights are treated in precisely the same way. It is evident that, under these circumstances, the difference between the two cannot fail to become apparent; and this way of regarding the matter shows also that the apparent displacement of the bright lines in the stellar spectrum is dependent upon the relative, and not further upon the absolute, motions of the star and of the earth. The mean of observations, equally distributed over the year, would thus give data for determining the relative motion in the line of sight of the star and of the solar system.

If the external source be the sun itself, it might be thought that the spectra must agree almost perfectly, the eccentricity of the earth's orbit being so very small. But the sun is a revolving body, and consequently a distinction must be made according to the part of the sun from which the light proceeds. It is found, in fact, that a very sensible shift takes place in the position of the dark lines according as the light under observation comes from the advancing or from the retreating limb. This circumstance has been successfully employed by Thollon and Cornu to distinguish between lines having a solar and a terrestrial origin. In the latter case it is a matter of indifference from which part of the sun the light proceeds.

In general optical theory the finiteness of the velocity of light is usually disregarded. Velocities at least ten times greater than that of the earth in its orbit are, however, known to astronomers; and such must begin to exercise a sensible influence upon radiation. Moreover, in so wide a generalization as the theory of exchanges, the neglect of even a small quantity is unsatisfactory. Prof. Balfour Stewart has discussed the influence of the motion of a plate exercising selective absorption upon the equilibrium of radiation within an inclosure. He argues that a disturbance will ensue, involving a violation of the second law of thermodynamics, unless compensated by some other effect not hitherto recognized. It appears, however, more probable that the whole radiation coming from and through a plate would not be altered by its motion. Whatever effect (in accordance with Doppler's law) the motion has upon the radiation from the plate, a similar effect would probably be produced upon the absorbing power. On this view the only result of the motion would be to change the wave-length of the rays most powerfully emitted and absorbed, but without disturbing the balance required by the theory of exchanges. The moving plate would in fact be equivalent to a stationary one of slightly different quality.

1887.

RAYLEIGH.

### SOCIETIES AND ACADEMIES.

LONDON.

Mathematical Society, March 10.—Prof. Greenhill, F.R.S., President, in the chair.—The President and Mr. S. Roberts, F.R.S., spoke upon the loss the Society had sustained by the recent decease of Dr. Hirst, F.R.S., touching more especially upon the great services he had rendered to it in the early days of its existence.—The following paper was read:—The simplest equivalent of a given optical path, and the observations required to determine it, by Dr. J. Larmor. To specify an optical path through a heterogeneous medium like the atmosphere, or through an arrangement of refracting substances like an optical instrument, we require the geometrical curve followed by the filament of light, and also the character of the modification produced on a filament following this path across the medium.

<sup>1</sup> American Journal, xxii. p. 120 (1884).

<sup>2</sup> "Over den invloed dien de beweging der aarde of de licht verschijnselen uitoefent." (Amsterdam, 1886.)

<sup>1</sup> This qualification is inserted in order to exclude such an experiment as that of Michelson, just described, in which an attempt is made to render sensible an effect depending on  $v^2/V^2$ .

<sup>2</sup> B.A. Report, 1871.



This division into filaments of waves, along whose course the energy of the radiation is propagated, is the true objective analysis of the light; and it also, on Sir W. R. Hamilton's principles, leads to more compact and comprehensive treatment than the ordinary analysis into linear rays. It is shown that the effect of the medium on any filament following the given path is exactly equivalent to that of a certain pair of thin astigmatic lenses with a common axis, on a beam passing across them; and a method is given for constructing these lenses from observations made at the two extremities of the actual optical path. It is shown, in continuation, that conjugate pairs of focal lines at the two ends of a filament are given by a 2 to 2 correspondence, whose general relations are exhibited graphically by the aid of a pair of conics, and various developments are made in this direction. There are, in general, no points which have conjugate foci; but, if a certain condition hold, there exist two transverse planes of points which have conjugate planes of focal points. This occurs only when the equivalent astigmatic pair of lenses have their principal sections parallel, so that the component refractions in these principal sections are independent of each other. It is only in this special case that the emergent filament can be constructed by means of rays, in Moebius's manner, by aid of the two conjugate pairs of focal planes. If a certain other condition is also satisfied, there is complete symmetry round the axis, except as regards a possible constant rotation of the filament; and then the optical path is equivalent to refraction by a single ordinary thin lens.—The President communicated a paper, by Prof. W. Burnside, on cases in which a hyper-elliptic integral of the first order can be expressed as the sum of two elliptic integrals.—Mr. Tucker read abstracts of the following notes:—On the analytical theory of the congruency, by Prof. Cayley, F. R. S.—On certain curves of the fourth order, and the porism of the inscribed and circumscribed polygon, by Mr. R. A. Roberts.—Notes on dualistic differential transformations, by Mr. E. B. Elliott, F. R. S. A perusal some time ago of De Morgan's paper in the Cambridge Transactions on the subject of the principle of duality in differential equations which bears his name led Mr. Elliott to notice a short note thereto, in which the author announced that after writing his paper he had found a note by Chasles, in which the method had been anticipated. Upon this, referring to Chasles's work ("Aperçu Historique," note xxx), he found that Chasles had stated and to a certain extent developed a theory on the subject of much wider generality. It occurred to Mr. Elliott that some further consideration might with advantage be given to Chasles's conclusions and their extension; and a portion of this paper is the result. It had previously occurred to the author that recent theories as to the transformation of differential expressions by interchange of dependent and independent variables, and in particular the theory of reciprocants, had a bearing on the more restricted or De Morgan duality, and even more on its simpler analogue as to ordinary differential equations, which had probably escaped notice. Another portion of these notes is devoted to the elucidation of this idea.—Prof. M. Hill made a few remarks on singular solutions; and the President spoke on the rectification of the Cartesian oval. It has been shown by Prof. Genocchi, of Turin (*Annali di Matematica*, 1864), and by Mr. Samuel Roberts (Proc. L. M. S. iii.), that the arc of a Cartesian oval can be expressed as the sum of three elliptic arcs. Taking a fixed oval (i.) and its conjugate oval (ii.) in a trifocal system of Cartesians, then as a variable orthogonal oval traces out on (i.) a certain arc, its conjugate oval traces out on (ii.) another arc; the sum of these arcs can be expressed by a single elliptic arc, while the difference is expressible as the sum of two elliptic arcs; thus leading to the theorems of Prof. Genocchi and Mr. S. Roberts.

**Anthropological Institute**, March 8.—Edward B. Tylor, F. R. S., President, in the chair.—Mr. J. Allen Brown read a paper on the continuity of the Palaeolithic and Neolithic periods. The deductions of the author are based on the large number of flint implements of Palaeolithic type which have been discovered during recent years at Eastbourne, East Dean, Cuckmere, and in other combs and dry valleys in England; at East Dean, &c., they are associated with compact aggregated deposits of flints and chalk rubble, evidently due to the erosion of the valleys and combs by underground water, as seen at Birling Gap, near Eastbourne. The valleys of Sussex have been subject to many changes during the concluding episodes (both glacial and sub-glacial) of the Quaternary period, and in many cases the older

forms of flint implements have been covered up and preserved by the deposit of loam and chalk rubble resulting from the waste of the surface of the land. Intermixed or associated with the flint implements of older types are others of transition form, to which he desired to see the term "Mesolithic" applied. The East Dean Valley appeared to contain flint implements forming a series ranging from the late Palaeolithic age to the polished stone period of true Neolithic. The old mining-shaft at Cissbury has furnished analogous specimens. Similar implements of the Palaeolithic type have been found in chalk rubble far away from the sea-board, and associated with the bones of the mammoth, tichorine rhinoceros, hippopotamus, and other Quaternary Mammalia, as well as the remains of various animals of species still living, showing that man was present in Southern Britain not only in the plateaux and river-drift periods, but also continuously into the so-called Neolithic epoch. The author alluded to the evidence derived from caves and rock-shelters and peat-beds, both in this country and in France, which pointed in the same direction. A large series of flint implements of Palaeolithic form from East Dean, &c., were exhibited, with specimens of corresponding forms from the river-drift; also a series showing the evolution of the axe or celt form from the simply chipped nodule of the plateaux drift, through the valley drift and transitional types to the highly finished celts of the Neolithic age, of which the forms were continued in the earliest stages of the age of copper and bronze. Other series were exhibited, showing in like manner the evolution of the spear-head and knife, &c.

**Zoological Society**, March 1.—Dr. A. Günther, F. R. S., Vice-President, in the chair.—The Secretary read a report on the additions that had been made to the Society's Menagerie during the month of February 1892, and called attention to two Short-winged Tyrants (*Machelornis rixosa*) purchased February 15, being the first examples of this bird that have reached the Society, and to a female Beatrix Antelope (*Oryx beatrix*) from Arabia, presented by Lieut.-Colonel Talbot, February 18.—Mr. J. Graham Kerr gave a short account of the expedition up the Rio Pilcomayo in 1890-91, which he had accompanied as naturalist. Mr. Kerr made remarks on the animals met with on the banks of the Pilcomayo, and exhibited a series of photographs illustrating the vegetation of the district and its native Indian inhabitants.—Mr. G. F. Hampson read a paper on stridulation in certain Lepidoptera, and on the distortion of the hind-wings in the males of certain *Ommatophorina*. The author attributed the clicking sound described by Darwin as produced by various species of the South American genus of Butterflies, *Angerona*, and confirmed by Wallace and other observers, to the presence of a pair of strong corneous hooks on the thorax, which play on a pair of curved hooks with spatulate ends attached to the inner margin of the fore-wing close to the base, and surrounded by a membranous sac which acts as a sounding-board. An account was given of a similar sound produced by the males of a Burmese moth of the family Agaristidae and of a buzzing sound in an allied Australian form, both of which have a patch of ribbed hyaline membrane below the costa of the fore-wing. The sound was attributed to the friction of spines, attached in the former to the first pair of legs, in the latter to the second pair, on the ribbed membrane. A description was then given of the transformation of the costal half of the hind-wing in the Noctuid genus *Patula* into a large scent-gland, and of the manner in which this had distorted the neurulation. The still greater distortion of the neurulation in the allied genus *Argida* was attributed to its once having possessed a similar scent-gland, now become rudimentary by disuse.—A communication was read from Prof. W. N. Parker, on the retention of functional gills in young Frogs (*Rana temporaria*), which he had succeeded in producing in specimens reared in his laboratory. Prof. Parker described the method employed with this object, and made remarks on the way in which the fore-limbs are protruded.—Prof. F. Jeffrey Bell read a paper entitled "A Contribution to the Classification of Ophiroids," to which were added descriptions of some new and little-known forms of this group.—Mr. M. F. Woodward gave an account of an abnormal Earthworm (*Lumbricus terrestris*) possessing seven pairs of ovaries situated on the eighth and following somites to the fourteenth.

#### OXFORD.

**University Junior Scientific Club**, March 4.—Mr. J. A. Gardner, of Magdalen College, President, in the chair.—Some investigations of the action of dry hydrochloric acid gas on dry carbonates were brought forward by Mr. F. K. L. Wilson,

Keble College, and Mr. R. E. Hughes, Jesus College. The authors showed that probably perfectly dry hydrochloric acid gas does not act on carbonates. Experiments were tried with the carbonates of calcium and barium.—Mr. J. L. Hatton, Hertford College, read a paper on some investigations, which he had been engaged upon, in conjunction with Mr. James Walker, on the motions of the nodal planes in a rotating bell. This work appeared in a recent number of the *Philosophical Magazine*.—This paper was followed by an account of the fixation of nitrogen by plants, by Mr. O. V. Darbishire, of Balliol College.

## PARIS.

**Academy of Sciences, March 14.**—M. d'Abbadie in the chair.—The Secretary commented upon the loss sustained by the Academy by the death of M. Léon Lalanne.—On conical vascular branches, and on the inductions to which they lead with regard to the organization of the vascular blood system, by M. Kanvier.—Researches on samarium, by M. Lecoq de Boisbaudran. By passing an electric spark from a large induction coil, without condensers, through solutions rich in samarium, and viewing the spark spectroscopically, lines were obtained at the wave-lengths 466.2, 462.7, and 459.3; and a wide band having a well-defined edge at  $\lambda$  611.2, and fading away to about  $\lambda$  622. The samarium bands undergo very marked variations when the position of the spark with respect to the meniscus of liquid is altered. This fact is thought to be of interest from the point of view of the supposed complexity of samarium. It is not impossible that there is a relation between the band 611-622 and the narrow line which Prof. Crookes observed when using mixtures of samarium and yttrium *in vacuo*, and which he attributed to the presence of a new element. M. Boisbaudran has observed this line, or one very near it, with different substances, and finds that its position varies sensibly with the nature of the solution employed. The narrow line is accompanied with a less refrangible and weaker one. With lanthanum sulphate mixed with a compound of samarium, the wave-length of the stronger line was determined as 612.7, and of the weaker 619.6. Prof. Crookes obtained the wave-length 609.—On a remarkable prominence, by M. H. Deslandres. The prominence was observed on the east limb of the sun on March 3, as the large spot-group of February was coming round it.—On frictionless gearings, by M. A. Rateau.—On periodic heat maxima observed in spectra furnished by flint and crown glass, and rock-salt, by M. Aymonnet. The heat maxima observed are separated by equal wave-lengths in the case of each of the prisms used, and, for rock-salt, the maxima appear to correspond to the fundamental vibrations of  $1, 2, 3, \dots, n$  systems of cubical molecules.—On some well-defined alloys of sodium, by M. Joannis. By the action of lead, in excess, upon sodammonium, a compound having the formula  $Pb_3Na_2 \cdot 2NH_3$  was obtained. An alloy of lead and potassium,  $Pb_3K$ , was obtained by the action of potassammonium, in excess, upon lead; an alloy of bismuth and sodium,  $BiNa_3$ , by treating pure bismuth, in excess, with sodammonium, and an alloy of antimony and sodium,  $SbNa_3$ , have similarly been produced.—On the analysis of minerals containing antimony, by M. Ad. Carnot.—On the microscopic structure of oolitic iron from Lorraine, by M. Bleicher. From the investigation it appears that the ferruginous oolites which have been studied consist of a central mineral or organic nucleus, single or multiple, surrounded by regular concentric layers of a substance rich in silica and organic matter.—On the vegetation of the vine, by MM. L. Roos and E. Thomas. Conclusions are given respecting the amounts of sugars present and the acidity of various parts of the vine plant at different stages of its growth.—Citric acid, by M. G. Massol. The heat of formation, in the solid state, of potassium and sodium citrates is greater than that of the corresponding carballylates. The augmentation is analogous to that observed when comparing malonic and succinic acids with tartaric, tartaric, and malic acids, and is to be attributed to the alcoholic hydroxyl group.—On some reactions of the isomeric amido-benzoic acids, by M. Oechsner de Coninck.—Calculation of the temperatures of ebullition of compounds derived from the paraffins by terminal substitution, by M. G. Hinrichs.—On the pyrogenous hydrocarbons formed in the compressed gas industry, by M. A. Brochet. The author has isolated and identified the following:—

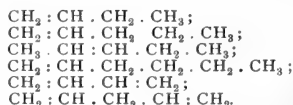

—The specific gravity of silk, by M. Léo Vignon.—Glycolysis in the blood, by M. Maurice Arthus.—Are there inhibitory nerves? by M. J. P. Morat.—On an anomaly in the great hypoglossal nerve, by M. Buffet-Delmas.—On the ovary and the egg of *Gobius minutus*, by M. Frédéric Guitel.—Note on the magnetic perturbations of March 11-13, 1892, by M. Th. Moureaux.

## BOOKS, PAMPHLETS, and SERIALS RECEIVED.

**BOOKS.**—Note-book of Agricultural Facts and Figures, 4th edition: P. McConnell (Lockwood).—A Year-book of Science, 1891: edited by Prof. Bonney (Cassell).—Willings's British and Irish Press Guides, 1892 (Willings).—Sitzungsberichte der K. B. Gesellschaft der Wissenschaften, Math. Naturw. Classe, 1891 (Prag).—Abhandlungen der Mathematisch-Naturwissenschaftlichen Classe der K. B. Gesellschaft der Wissenschaften von den Jahren 1890-91, vii. Folge, 4. Band (Prag).—Health Springs of Germany and Austria, 2nd edition: F. O. Buckland (Allen).—The School Calendar, 1892 (Whittaker).—Silk Dyeing, Printing, and Finishing: G. H. Hurst (Bell).—Le Poil des Animaux et les Fourrures: Lacroix Daniard (Paris, Baillière).—Les Fleurs à Paris: P. L. de Vilroin (Paris, Baillière).—Statistics of the Colony of Tasmania for the Year 1890 (Tasmania, Strutt).—Anatomie et Physiologie Comparées de la Pholade Dactyle: Dr. R. Dubots (Paris, Masson).

**PAMPHLETS.**—Neue Integrationsmethoden auf Grund der Potenzial-Logarithmal und Numeral-rechnung: Dr. J. Bergbom (Stuttgart).—Neue Rechenmethoden der Höheren Mathematik, Dr. J. Bergbom (Stuttgart). O. Theori Ploch: E. Weyr (V. Praze).—Jahresbericht der K. B. Gesellschaft der Wissenschaften für das Jahr 1891 (Prag).

**SERIALS.**—Beiträge zur Kenntniss der Orchideen von H. G. Reichenbach fil. fortgesetzt durch F. Kränzlin; Dritter Band, Fünftes Heft (Leipzig, Brockhaus).—Proceedings of the American Philosophical Society, vol. xxix. No. 135 (Philadelphia).—Bulletin de L'Académie Impériale des Sciences de St. Pétersbourg, Nouvelle Série, II, xxiv. (St. Pétersbourg).—Bulletin of the New York Mathematical Society, vol. I, No. 6 (New York).

## CONTENTS.

	PAGE
The History of Determinants. By P. A. M.	481
The Evolution of Man. By A. M. M.	482
Our Book Shelf:—	
Bonavia: "Philosophical Notes on Botanical Subjects."	483
—W. B. H.	
Beddard: "The Zoological Record for 1890"	483
Letters to the Editor:—	
Sun Pillar. (Illustrated).—Annie Ley	484
New Comet.—W. F. Denning	484
First Visible Colour of Incandescent Iron. (Illustrated).—Capt. A. Noble, F.R.S.	484
Poincaré's "Thermodynamics."—Prof. H. Poincaré	485
Ornithology of the Sandwich Islands.—Albert F. Calvert	485
Superheated Steam.—J. Macfarlane Gray	486
Phonomy.—A. B. Basset, F.R.S.; M. am Ende; G. C. R.	486
The Tudor Specimen of Eozoon.—J. W. Gregory	486
The Theory of Solutions.—J. W. Rodger	487
The Limpet's Strength.—J. Lawrence-Hamilton, M.R.C.S.	487
Technical Education for Novelists.—W.	487
The Origin of the Year. I. (Illustrated). By J. Norman Lockyer, F.R.S.	487
The Winter Storms of Northern India. (Illustrated). By Henry F. Blanford, F.R.S.	490
The Magnetic Storm of February 13-14, 1892. (With Chart)	493
William Dittmar. By A. C. B.	493
Serenio Watson	494
Notes	494
Our Astronomical Column:—	
Fuzziness of some Variable Stars	497
Astronomical Possibilities at Considerable Altitudes	498
Increase of the Earth's Shadow during Lunar Eclipses	498
The New Star in Auriga	498
Aberration. (Illustrated). By Lord Rayleigh, Sec. R.S.	499
Societies and Academies	502
Books, Pamphlets, and Serials Received	504

THURSDAY, MARCH 31, 1892.

## A ZOOLOGIST ON DISEASE.

*Leçons sur la Pathologie comparée de l'Inflammation faites à l'Institut Pasteur en Avril et Mai, 1891.* Par Élie Metschnikoff, Chef du Service à l'Institut Pasteur. (Paris: G. Masson, 1892.)

DR. METSCHNIKOFF has in this volume given a clear account of the general basis of his phagocyte theory, tracing the significance of amœboid cells or phagocytes from the Protozoa upwards through various groups of animals to the higher Vertebrates. He adduces a vast number of facts, many of them new and now for the first time published (with many beautiful coloured figures), others cited from his own earlier publications and from the work of cotemporary observers, to show that inflammation is essentially a reaction of the phagocytes contained in animal bodies to the presence of injured tissue or intrusive particles—a reaction which consists in active movement to the injured spot on the part of the phagocytes, and the ingulfing and digestion by them of the offending matters.

This volume appears opportunely. It will, I venture to predict, be regarded as epoch-making, establishing on a solid basis the theory of phagocytes, first sketched by Metschnikoff about ten years ago,<sup>1</sup> and repeatedly confirmed and elaborated by his brilliant researches. It will enable the biological world to appreciate the theory at its true value as one of the great generalizations of biology, worthy to take rank, after Darwin's theory of natural selection, with Virchow's cellular pathology, and Pasteur's doctrine of the Bacterial origin of fermentations and infective diseases.

It is worth noting (and weighing well the lesson conveyed) that the flood of light which the phagocyte doctrine throws upon the nature and processes of disease is not due to a medical man, nor even to one of those industrious observers of the physical properties of the tissues of the frog and the rabbit, who pursue their researches by the aid of delicate recording drums, balances, and pendulums, and have for some unexplained reason at the present day been granted the monopoly of the ancient and comprehensive title "physiologist."

Just as the penetrating theories of Pasteur, the chemist, on infective disease, were opposed by the medical profession, who regarded a chemist as an intruder in their domain, so the medical pathologists and the more narrow-minded devotees of the kymographion have, to a large extent, opposed, rejected, and attempted to ridicule, Metschnikoff's doctrine of phagocytes. Unfortunately, medical education is too little based on thorough biological training, and in this country the so-called "physiologist," so far from being a naturalist, plunges into the difficult and not very fruitful task of applying the delicate apparatus of the experimental physicist to the measurement of processes occurring in the higher Vertebrata,

<sup>1</sup> Metschnikoff's comprehensive view of the significance of phagocytes was first made known to English readers by translations of two of his earlier papers, almost immediately after their original publication, in the *Quarterly Journal of Microscopical Science*, 1884. They were entitled "Researches on the Intra-cellular Digestion of Invertebrates," and "The Ancestral History of Inflammation."

without ever attempting to gain a competent knowledge of the ultimate structure and vital processes of the series of lower animals. Had our physiologists and pathologists the advantage of even a moderate instruction in zoology, comparative anatomy, and embryology, they would be making progress towards dealing with many of the problems the solution of which they in vain seek to wring from the unfortunate frog and rabbit. Certainly, it is not possible for a physiologist or pathologist with any pretensions to an adequate knowledge of the structure and activities of the organs and tissues of lower as well as higher animals to fail to see the great value of the generalization which brings together under a common term the phenomena of intra-cellular digestion, of embryonic cell-layers, of inflammation, and of immunity to bacterial disease—which "explains" at once the mesoblast of the Echinoderm-larva and the very existence of the colourless corpuscles of vertebrate blood. The man who sneers at "Metschnikoffism,"—that is, the explanation of the phenomena of inflammation and infective diseases in Vertebrate animals by a comparative study of these phenomena in Protozoa, Sponges, Jelly-fish, Worms, Crustaceans, and Mollusks—must be held to be either very ignorant or morbidly prejudiced against zoological studies.

Elias Metschnikoff has been known for more than five-and-twenty years as the most productive and accurate investigator of the embryology of marine Invertebrata, such as the Sponges, Meduse, Echinoderms, and Worms. The amount and value of his researches in this field had placed him by general consent in the very first rank, by the side of his distinguished fellow-countryman Kowalewsky, when, ten years ago, he was led to direct his attention more especially to the study of the activity of the amœboid corpuscles of the blood and tissues of certain transparent organisms in resisting infection by vegetable parasites; and thence to other questions of a similar nature. Lately he has retired from the Professorship of Zoology which he held at Odessa, and accepted a position giving him the control of an admirable laboratory in the Institut Pasteur in Paris.

Metschnikoff commences his book with the statement: "It is solely in my quality of zoologist that I have decided to deliver these lectures on a subject which belongs to the domain of pathology." Just as formerly, in comparative anatomy, account was taken only of Man and the Vertebrata, so now, our author says, in medicine up to the present time, all the pathological processes which go on in the lower animals have been left out of consideration. And yet the study of these lower animals, which present simpler and more primitive conditions than do Man and the Vertebrates, is capable of furnishing us with the key, as it were, of those complicated pathological phenomena which are most interesting for medical science. Disease and pathological processes have—their evolution, just as Man and the Vertebrates themselves have.

After describing and figuring examples of parasitic infection among Infusoria, M. Metschnikoff gives details establishing the important property of "chemiotaxis"—positive and negative—as characteristic of amœboid protoplasm, selecting the plasmodium of Mycetozoa for special study. He next discusses the passage from uni-

cellular animals to the Metazoa, and his embryological theory of the "phagocytella." The reaction of the mesodermic phagocytes of sponges to foreign matters introduced into the substance of these animals is described; and, subsequently, similar phenomena in Cœlentera, Echinodermata, and Worms are cited, and illustrated by original drawings. It is shown that in these Invertebrates the phagocytes attack and invest, either singly or in fused masses, not only inorganic particles, but large parasites, and also intrusive parasitic Bacteria. Thence he passes to organisms—the Mollusca, Arthropoda, and Tunicata—which have a well-developed blood-system. He shows that here, too, there are no special "vascular" phenomena excited by conditions which in higher Vertebrates produce "inflammation," but solely a "phagocyte reaction" or resistance. Numerous cases of infectious bacterial and fungal diseases in Arthropoda are described, and the action of the phagocytes in combating the intrusive parasites by ingulfing and digesting them is demonstrated. Even when we come to the Vertebrates, it is shown that, in regions of the median fin of the tadpole of the Axolotl, an inflammation can be excited which is purely phagocytic, and in which the blood-vessels and their contents take no part.

The peculiarity, however, of inflammatory processes in adult and higher Vertebrata is, that the blood-vessels come into play. The amoeboid corpuscles floating in the blood by active movement (of a chemiotactic nature), push their way through the walls of the capillaries (diapedesis) in the region which is infected or injured, and join their forces to those of the tissue phagocytes in investing and destroying the injurious particles.

A detailed study of the leucocytes of the blood and lymph of Vertebrates follows, which are distinguished as (1) lymphocytes, (2) uninuclear, (3) eosinophil, and (4) neutrophil or multinuclear leucocytes. Metschnikoff shows that the two varieties of leucocytes which play the chief part in inflammation—viz. the uninuclear and the neutrophil—are endowed with a marked chemiotactic and physiotactic sensibility, are capable of amoeboid movements, and apt to ingulf and to digest various foreign bodies, notably many kinds of living Bacteria. In the Amphibia he shows that the multinuclear leucocytes can transform themselves into the uninuclear form, and become fixed cells of the connective tissue. In Vertebrates generally, uninuclear leucocytes can be transformed into epithelioid and giant cells. What is true of leucocytes is also true of other migratory cells.

The ninth, tenth, and eleventh lectures deal with such topics as the endothelium of vessels, the dilatation of vessels, chronic inflammations—tubercle being taken as a type—serous inflammation, bactericidal power of serous humours and exudations; and the antitoxic property of the serum.<sup>1</sup> A most important and interesting study of

the phenomena of resistance to the tubercle bacillus on the part of the giant-cells of the Algerian Rodent *Meriones Shawi* is given in some detail.

The last lecture treats of some previous theories of inflammation, summarizes the facts which serve to establish what Metschnikoff calls the biological theory of inflammation, and repels some attacks recently made on it. The theory is formulated in these words: "Inflammation must be looked upon in its entirety as a phagocytic reaction of the organism against irritative agents—a reaction which sometimes is carried out by wandering phagocytes only, sometimes with the assistance of the vascular phagocytes or with that of the nervous system." The last words refer to the intervention of the vaso-motor nervous centres.

Medicine, says our author in order to gain her assigned objects must make use of knowledge drawn from all less complicated branches of science; and amongst others from that biology which studies organisms in their living state and their natural evolution.

The services rendered will be reciprocal. General biology, he points out, can gain great advantage by embracing in the sphere of its studies the morbid phenomena now relegated to the pathologist. Too often biology finds difficulties in the study of the processes of evolution because the phenomena are presented to the observer in an already accomplished form. To observe with clearness the play of the general law of natural selection, we must study the less stable phenomena, the less perfected organizations—in a word, the phenomena in which natural selection can be observed every day. Now it is precisely the phenomena of disease and the reactions connected with it—the struggle between the organism and its aggressors—which offer the best opportunity for a close study of the operation of natural selection.

It has been impossible to do justice to this remarkable book in a short review. It has the special quality of carrying conviction to the reader's mind by the fact that every assertion is supported by a number of well-chosen observations or experiments which are described with a lucidity and precision characteristic of a man thoroughly familiar with the minutest details of the things of which he speaks. It is to be hoped that it may have, amongst other consequences, that of silencing certain medical "educationists," who deny that zoology is a necessary or useful accompaniment of the chemical and physical study of living things. Its pages contain convincing proof that medicine has gained more real knowledge and practical help from modern zoology than from the elaborate experimentation on higher Vertebrates which is directed by narrow-minded ignorance of the simpler expressions of animal organization.

E. RAY LANKESTER.

<sup>1</sup> I cannot let pass this opportunity of pointing out an evolutionary parallel in the history of phagocytes which tends to harmonize to some extent the views of those who insist on the bactericidal and the anti-toxic properties of serum, with Metschnikoff's view that the phagocytes are of prime importance. In the recent debate at the Pathological Society of London, it was pointed out by several speakers that even if it be admitted that the serum and exudations have, in relation to certain special cases, these properties—or rather contain substances having these properties—those substances must be derived from the living cells of the organism, and probably from leucocytes. The parallel to which I refer is that of intra-cellular and cavity digestion. The alimentary canal of some lower animals is lined by phago-

cytes, which individually ingulf solid particles of food, and digest them by means of ferments, acids, &c., formed within the phagocytes. A later stage of evolution of the digestive system consists in the discharge by these cells of the food-dissolving substances elaborated by them into the common liquid occupying the cavity which they surround. The food-dissolving substances are no longer found exclusively in the cells, but in the liquid which bathes them. Yet no one ascribes a special power to the gastric juice, or hesitates to trace its qualities to the transformed intra-cellularly-digesting cells. So with bactericidal and anti-toxic juices: they must be traced (when their existence is proved) to the modification of the *modus operandi* of intra-cellularly-digesting phagocytes.

## TWO BOOKS OF AFRICAN TRAVEL.

*Travels in Africa during the Years 1879-83.* By Dr. Wilhelm Junker. Translated from the German by A. H. Keane, F.R.G.S. (London: Chapman and Hall, 1891.)

*My Second Journey through Equatorial Africa.* By Hermann von Wissmann. Translated from the German by Minna J. A. Bergmann. (London: Chatto and Windus, 1891.)

THE first of these two books deals with a part of the period during which the late Dr. Junker carried on his second series of explorations in Central Africa. On his return to St. Petersburg in September 1878, after his first journey to the Egyptian Sudan, he had no intention of paying another visit to that region. Nevertheless, within a year he was hard at work preparing for a similar expedition, and on October 10, 1879, he found himself on board the steamer which took him to Alexandria. With as little loss of time as possible he made for Khartum, whence he started by the *Ismailia*, on January 31, 1880, for Meshra Er-Req, on the Bahr el-Ghazal. This part of the journey was made extremely tedious by the "sudd," or grass-barriers, through which the steamer had to force its way. The vegetation of which "sudd" is composed grows luxuriantly in back-waters; and great masses of it are brought by winds or by flood-waters into the river. These masses may either drift harmlessly with the currents, or coalesce into formidable barriers. Sometimes they become so compact that a steamer cannot penetrate them, and they must be broken up by special apparatus. This is especially the case in the Bahr el-Jebel. In the Bahr el-Ghazal the barriers are troublesome enough, but are not of quite so tough a texture.

At Meshra Er-Req Dr. Junker met Gessi Pasha, who was at that time Governor of all the Equatorial Provinces. The two men had a warm regard for one another; and after a little delay, due to Gessi's numerous engagements, they made an excursion together to Dem Soliman, the most important of the Arab settlements visited by Dr. Junker in the negro lands. Here they parted, never to see one another again, for Gessi died about two years afterwards at Suez. From Dem Soliman Dr. Junker travelled in a south-easterly direction to the territory of Ndoruma, a native chief, who, although rather fickle, was of considerable service to him. In this territory, on the banks of the Werra, Dr. Junker established a station called Lacrima, where he remained about two months. He then proceeded southward, crossing the Welle, and residing some time with Prince Mambanga, from whose territory he went eastward to Tangasi. Before the end of 1880 he was back at Lacrima, which he had left in charge of his companion, Bohndorff. In the course of 1881 Dr. Junker travelled among several different tribes, arriving about the end of the year at the domain of Prince Bakangai from Hawash station. At this point the narrative stops, to be continued, no doubt, in another volume, although on this point nothing is said either by the translator or by the publishers.

So many changes have taken place since 1881 in the regions visited by Dr. Junker that his account of the mutual relations of the native tribes is now, of course, out of date; but that does not in any way diminish the

value of his descriptions of their permanent characteristics. He had a remarkable power of winning the confidence and respect of the people, and thus had many opportunities of forming a trustworthy estimate of their intellectual and moral faculties. Upon the whole, the impression they produced upon him was not unfavourable. He seems to have been especially pleased with some aspects of the character of the Mangbattus, his observation of whom enabled him to say that the "tender side" of negro feeling had been called in question unjustly. The women of this tribe hold a relatively high position. They are allowed to take part with the men in public gatherings, and some of them were occasionally able to act as Dr. Junker's interpreters. The Mangbattus have a decidedly artistic faculty, which they display most effectively in the making of iron weapons. They have a kind of knife which seemed to Dr. Junker "unsurpassed for the beauty and originality of its numerous forms"; and their spear-heads "present an amazing variety of types in the size and shape of the barbs, teeth, and tips." They also "display surprising technical skill in the artistic treatment of diverse wooden utensils and earthenware vessels, which, as in all these negro lands, are turned out without the aid of the potter's wheel." Dr. Junker's geographical observations relate to a comparatively small area, but their thoroughness gives them a unique place in the literature of African exploration; and naturalists will read with interest everything he has to say about the flora and fauna of the districts he traversed.

Scientifically, Major Wissmann's book is of less importance than Dr. Junker's. It records his experiences during his second journey through Africa, which was undertaken in 1886, when he was still in the service of the King of the Belgians. His instructions were to open various parts of the interior of the Congo State; to investigate, and, as far as possible, counteract, the proceedings of slave-hunters; and to report on the countries bordering the Congo State towards the south-east. He made in the first instance for the Bashilange country, where he remained for some time, exploring the region and settling various political affairs. In November he left Luluaburg at the head of a caravan consisting of 900 persons, who accompanied him eastward to the neighbourhood of Nyangwe, on the Upper Congo, whence they were taken back to their native country by Lieutenant Le Marinel. At Nyangwe Major Wissmann was detained by Zefu, Tippu Tib's son, but ultimately he was allowed to depart, and reached the east coast by Lakes Tanganyika and Nyassa, and the River Shire.

The most important parts of the work are those relating to the outrages committed by the infamous slave-hunters; but there are also a good many valuable passages in which the author embodies the results of ethnographical study. Among other peoples described by him are the dwarfs whom he met in the primeval forest. They reminded him of portraits he had seen of Bushmen. They were "of a brown-yellowish colour, or rather light yellow, with a brown shadowing." Their demeanour was "timidly modest," and he had to be careful not to touch them, as they were always ready to take to their heels. An agreeable impression was made by the rounded figures, fresh complexions, and graceful, easy, quiet movements of the young, but the old "might literally be called painfully

ugly"—a fact which seems to be due to their poor food and roving life.

Both books are illustrated, and each is supplied with a map. The map accompanying Dr. Junker's volume does not indicate his routes, which the reader, therefore, often finds some difficulty in tracing.

*PROFESSOR TYNDALL'S LATEST BOOK.*

*New Fragments.* By John Tyndall, F.R.S. (London: Longmans, 1892.)

WE have here a miscellaneous collection dealing with various subjects—scientific, theological, biographic, and autobiographic. Some of the papers are lectures delivered at the Royal Institution or elsewhere, some are magazine articles, and a few have been added for the present volume.

The personal recollections of Thomas Carlyle will be read with interest, especially the account of his journey to Edinburgh and the delivery of his Rectorial address.

The article on Pasteur sketches with keen appreciation the remarkable series of investigations which, beginning with the optical properties of unsymmetric crystals, were diverted by circumstances to the life-history of microscopic organisms, and the nature of fermentation.

The sketch of the remarkable career of Count Rumford derives increased interest from local information gathered during a visit to the scenes of Rumford's boyhood in New England.

The lecture on Thomas Young contains a vivid delineation of his personal qualities, and, besides tracing his achievements in physical science, gives a very clear and intelligible account of the methods by which he succeeded in deciphering the Egyptian hieroglyphics. In the accompanying narrative, his openness and plain dealing are strongly contrasted with the crafty suppressions of his rival, Champollion, who, being a professional antiquarian, appears to have thought it intolerable that he should be beaten in his own special province by an outsider.

To many readers, the most interesting portions of the "Fragments" will be those which are autobiographic.

An address, delivered at the Birkbeck Institution in 1884, contains a sketch of Prof. Tyndall's early career, first as a draughtsman in the Ordnance Survey, then as an Ordnance surveyor in the field, next as a railway surveyor in the rush of work which sprung from the "railway mania." Here is a specimen of his recollections of that date:—

"Among the legal giants of those days, Austin and Talbot stood supreme. There was something grand, as well as merciless, in the power wielded by those men in entangling and ruining a hostile witness; and yet it often seemed to me that a clear-headed fellow, who had the coolness, honesty, and courage not to go beyond his knowledge, might have foiled both of them. Then we had the giants of the civil engineers—Stephenson, Brunel, Locke, Hawkshaw, and others. Judged by his power of fence, his promptness in calculation, and his general readiness of retort, George Bidder as a witness was unrivalled. I have seen him take the breath out of Talbot himself before a Committee of the House of Lords. Strong men were broken down by the strain and labour of that arduous time. Many pushed through, and are still amongst us in robust vigour. But some collapsed; while others retired with large fortunes it is true, but

with intellects so shattered that, instead of taking their places in the front rank of English statesmen, as their abilities entitled them to do, they sought rest for their brains in the quiet lives of country gentlemen. In my own modest sphere, I well remember the refreshment occasionally derived from five minutes' sleep on a deal table, with Babbage and Callet's 'Logarithms' under my head for a pillow."

We next find him as a master at Queenwood College, Hants, where he had Frankland for a colleague.

"Queenwood College had been the Harmony Hall of the Socialists, which, under the auspices of the philanthropist, Robert Owen, was built to inaugurate the Millennium. The letters 'C. of M.,' Commencement of Millennium, were actually inserted in flint in the brick-work of the house."

Having saved some two or three hundred pounds, he went with Frankland in 1848 to study science in Germany, and selected Marburg as a place where he could live cheaply amid agreeable surroundings. Here, if the mists of intervening years have not unduly magnified the past, we must believe that he worked without weariness for sixteen hours a day. There were about three hundred students. Bunsen was the Professor of Chemistry, and appears to have given great prominence to chemical physics. His lectures included the electric telegraph, and a very full exposition of Ohm's law; and in the department of heat he made complimentary references to Joule.

In process of time our student began to make original investigations, and his first paper was on the phenomena of water-jets. It included the remark that the musical sound of cascades and rippling streams, as well as the sonorous voice of the ocean, was mainly if not wholly due to the breaking of air bladders entangled in the water.

After taking his degree at Marburg, he came over to England, but soon returned with his friend the late Prof. Hirst to Germany, where he studied at Berlin under Magnus, and met Dove, Ehrenberg, Mitscherlich, Du Bois-Reymond, Wiedemann, Clausius, Poggendorff, and Humboldt.

The happy associations of University life strengthened the predilections which originally attracted him to Germany, and he professes great admiration for the German character, which, alike in science and in war, aims not at glory, but at the discharge of duty.

Further gossip of an autobiographical kind is furnished under the head of "Old Alpine Jottings," which occupy the last seventy pages of the volume. Here we find him recruiting exhausted nature, after intellectual toil, by arduous climbing on icy slopes, over fearful precipices, and under a fusillade of boulders shooting down from the heights above.

Perhaps the most vigorous piece of writing in the book is that which is placed first—a lecture on Sabbath observance, delivered in 1880 before the Glasgow Sunday Society; and we must not omit to mention the second article, which gives a very full account of Goethe's work on colour. It pays a high tribute to Goethe's acuteness as an observer, but gives an unsparing exposure of his weakness as a scientific theorist.

The volume, though not ambitious, contains much pleasant reading.

J. D. E.

## OUR BOOK SHELF.

*A Treatise on Chemistry.* By Sir H. E. Roscoe, F.R.S., and C. Schorlemmer, F.R.S. Vol. III. "The Chemistry of the Hydrocarbons and their Derivatives; or, Organic Chemistry." Part VI. (London: Macmillan and Co., 1892.)

THE present section of this well-known work deals with the derivatives of naphthalene and the allied hydrocarbons—phenanthrene, chrysenes, &c.; also with the compounds containing two or more benzene nuclei directly united, such as diphenyl.

The extraordinary expansion which this particular branch of organic chemistry has undergone during the last fifteen years is due in part doubtless to the fascination of the various problems of constitution which these compounds offer, and to the well-founded assurance that Kekulé's benzene theory, which had thrown so much light on the subject of benzene itself and its more immediate derivatives, would prove an equally trustworthy guide in the case of the more complex hydrocarbons of the same class. But it is doing no injustice to pure chemists to say that a great part of this expansion is attributable to the fact that numerous valuable practical applications have been found for some of the compounds in question.

In 1876, when Wurtz published his "Progrès de l'Industrie des Matières Colorantes Artificielles," the colouring-matters derived from naphthalene might be counted on the fingers of one hand, and not more than two of these—Magdala red and Manchester yellow—were really manufactured; whilst from diphenyl not a single dye-stuff had been prepared. At the present moment, only a specialist in this branch could estimate, even approximately, the number of the naphthalene dyes; and within the last few years another important class of dyes, possessing the hitherto unknown property of dyeing cotton without a mordant, has been discovered among the derivatives of diphenyl.

The industrial source of much of our knowledge in this branch of chemistry is clearly shown in the fact that in the work now before us the references are not confined to the familiar scientific periodicals, but extend to the patent literature of various countries and to works like Schultz's "Steinkohlenther" and Friedländer's "Theerfarben." Without going into unnecessary detail, the authors succeed in giving all which it is necessary for the student of organic chemistry to know regarding these matters.

The questions of constitution are treated very fully and clearly. The reader who wishes to gain an idea of what organic chemists have accomplished, in the solution of problems which but a few years ago would have been regarded as utterly beyond the scope of rational investigation, cannot do better than study carefully the chapter on the constitution of the naphthalene derivatives.

The authors continue to follow their excellent practice of giving interesting historical details by way of introduction to the study of the more important compounds.

*The Oak: a Popular Introduction to Forest Botany.* By H. Marshall Ward, M.A., F.R.S., F.L.S. "Modern Science Series," edited by Sir John Lubbock, Bart., M.P. 171 pages, and Index, 2 Plates, and 51 Woodcuts. (London: Kegan Paul, Trench, Trübner, and Co., Ltd., 1892.)

THIS little book fills a distinct gap, as it is the first time that a primer intended specially for students of forestry has been issued in England. Prof. Marshall Ward has been for many years the Lecturer on Botany at the Royal Indian Engineering College at Cooper's Hill, and therefore understands thoroughly what is required. He has followed for his plan the taking of a single tree—the oak—

and dealing with it exhaustively. After a general introduction, he deals first with the acorn and its germination, describing fully the embryo and its epidermis, the vascular bundles of the former and its cells, and the character of their contents. He tells us that two years elapse before the supply of food stored up in the two thick cotyledons is exhausted, and it is not until the tree is from sixty to a hundred years old that good seeds are obtained from it. Then he describes the seedling and young plant—first the root and its tissues, and then the stem, buds, and leaves, and their microscopic structure. Then he turns to the full-grown tree, and describes its root-system, shoot-system, inflorescence, flowers, fruit, and seed. Next he deals with the timber of the oak, its structure, and technological peculiarities. Then he treats of the cultivation of the tree, and the injuries and diseases to which it is liable from the attacks of insects and fungi. He concludes with a short chapter on the relationships of the oaks and their distribution in space and time. The genus is characterized by the cupule, in which the acorn is inclosed, which represents a one-flowered involucre. There are three cells in the ovary, and two ovules in each; but nearly always two of the cells and five of the ovules are obliterated before the seed is perfected. About 300 species of the genus *Quercus* are known. It is spread universally through the north temperate zone. Prof. M. Ward is mistaken in supposing there are no oaks in South America. Two species have long been known in the Northern Andes—*Quercus tolimensis* and *Quercus Humboldtii*—both of which are described and figured in Humboldt and Bonpland's "Plantes Equinoxiales." There are nearly sixty species in India, and it is there that we get the genus connected with the other Cupuliferæ by passing through *Castanopsis* into *Castanea*. The oaks go back to the Cretaceous period, and a large number of fossil forms are known. Their delimitation into species is very difficult. In Britain we have only a single species, *Quercus Robur*, with two sub-species *Q. pedunculata* and *sessiliflora*, well enough marked in their extreme forms, but passing into one another by gradual stages of transition, which constitute what has been called *Quercus intermedia*. The book is clear and well arranged, and will be found thoroughly adapted to fulfil its purpose, and is illustrated by a large number of excellent figures, some of which are original and some borrowed from German text-books. J. G. B.

*The Elements of Plane Trigonometry.* By R. Levett and C. Davison. (London: Macmillan, 1892.)

THOUGH the spirit of De Morgan's writings pervades these "Elements," there is ample evidence that the writers have taken an immense amount of pains in bringing them fully up to date. We have long given up looking for originality in a treatise on trigonometry; indeed, in a text-book for use in schools such a feature is hardly desirable, but there are not wanting here many novel features in the matter introduced and in its mode of treatment. De Morgan's influence is shown "in the use of the negative hypotenuse in defining the ratios, in the more definite meaning assigned to the notation for inverse functions, the manner in which the addition formulæ are extended to any number of variables, the geometrical treatment of the hyperbolic function and of complex numbers, and in the two-fold generalization of a logarithm to a given base." Another work to which the authors are indebted in Parts II. and III. is Prof. Chrystal's masterly treatise on algebra. In fact, they are *au courant* with whatever has recently been written bearing in any way upon their subject-matter.

The book is divided, like ancient Gaul, into three parts. The first treats of arithmetical quantity, in five

chapters; the second of real algebraical quantity; and the third of complex numbers. The first two parts contain what is requisite for school use, the third is beyond the ordinary run of junior students. The whole has, we believe, stood the test of class work. In the second part the application of trigonometry to surveying is made interesting by treating the subject as practically as possible. There is a copy from a photograph of a theodolite, and a conversational description of the same, and in Part I, through the permission of the publishers, there is printed a portion of the map of the *Mer de Glace* given in the "Life of Prof. Forbes." These little points are likely to interest young students. Of course the hyperbolic functions are discussed, but they are discussed in a way that is novel to us in some of the details; for instance, geometrical proofs are given of  $\cosh(u+v)$  and  $\sinh(u+v)$ . These strike us as being very elegant and quite within school range, as they need only a moderate acquaintance with the properties of the rectangular hyperbola. A short space is occupied with the Gudermannian function, and a table of approximate values of hyperbolic functions is given in the same section. The section on convergency and continuity of series, and, in fact, the whole discussion of series, is very carefully done.

Our summing up is that the book is one of the best we have met with on the subject, and quite fitted to hold its own against the two or three formidable rivals that have lately appeared in the field. There is a plethora of carefully chosen examples, which we advise the junior student to use with Prof. Chrystal's caution in mind: "I should much deprecate the idea that any one pupil is to work all the exercises (in the 'Algebra') at the first or at any reading. We do too much of that kind of work in this country." The text is further illustrated by many *graphs* of different functions, and answers, carefully tested from working with pupils, are appended at the end, with tables of the logarithms required for the exercises.

*Les Fleurs à Paris: Culture et Commerce.* Par Philippe L. de Vilmorin. (Paris: J. B. Baillière et Fils, 1892.)

THE trade in cut flowers is now quite an important department of commerce, and it is rather surprising that a good many attempts have not been made to give a full and connected account of it. In the present volume M. de Vilmorin deals with the subject chiefly in its relation to Paris, and he has brought together many facts which will be of interest both to lovers of flowers and to students of social economy. He describes the various ways in which the trade is organized in the French capital, the sources from which the flowers are derived, the manner in which they are cultivated, and the means by which they are distributed. He then presents an account of the various kinds of flowers used for decorative purposes, giving in simple language such botanical details as are likely to be intelligible and attractive even to non-scientific readers. The volume is abundantly and very prettily illustrated.

*Health Springs of Germany and Austria.* By F. O. Buckland, M.D. Second Edition. (London: W. H. Allen and Co., 1892.)

THIS little book ought to be of considerable service to invalids who may desire to obtain aid in the choice of a Continental health resort. The author does not profess to present elaborate details as to the various springs with which he deals; but he says enough about each to give a sufficiently clear idea of its merits and defects. He offers also some good general remarks on the nature and uses of health springs. In the present edition he has made little change, but he has increased the value of the book by adding an index.

NO. 1170, VOL. 45]

## LETTERS TO THE EDITOR.

[The Editor does not hold himself responsible for opinions expressed by his correspondents. Neither can he undertake to return, or to correspond with the writers of, rejected manuscripts intended for this or any other part of NATURE. No notice is taken of anonymous communications.]

### Heat Engines and Saline Solutions.

I HAVE nothing to modify in what I have written under the above heading (p. 438); but to deal completely with all the questions raised by Mr. Macfarlane Gray (p. 486) would require half a treatise. I will limit myself to a few brief remarks.

(1) In Carnot's engine there is no (separate) boiler or condenser.

(2) When I spoke of the various parts of the working substance being in equilibrium with one another, I referred to complete equilibrium, thermal as well as mechanical. If the temperature varies from one part to another there is no equilibrium.

(3) On the above understanding the pressure of vapour in equilibrium with a saline solution of given strength is a definite function of the temperature.

(4) Let me suggest that the origin of the difficulty may lie in the phrase "superheated vapour," which has not so definite a meaning as Mr. Gray seems to ascribe to it. Whether vapour be superheated or no, depends, not only upon the condition of the vapour itself, but also upon the bodies with which it is in contact. Vapour which is merely saturated in contact with a saline solution must be regarded as superheated when contact with the solution is cut off. In the first situation it would condense upon compression, and in the second situation it would not.

In conclusion, I will hazard the prediction that, if the heat engines of the distant future are at all analogous to our present steam engines, either the water (as the substance first heated) will be replaced by a fluid of less inherent volatility, or else the volatility of the water will be restrained by the addition to it of some body held in solution.

RAYLEIGH.

### On Earth Vibrations.

IT seems that the earth, once set in vibration, maintains this state for a long time before coming to rest. The observers of Greenwich (see Major H. S. Palmer in the Transactions of the Seismological Society of Japan, vol. iii., p. 148) found that from time to time, at considerable intervals, there was an evening when the usual observations for determining the collimation-error of the transit-circle by means of reflection in a tray of mercury could not be taken, on account of the constant trembling of the surface of the mercury, which on such occasions continued until long past midnight. These are occasions when crowds of the poorer classes of London flock for amusement to Greenwich Park. A favourite pastime with the young people, often prolonged until after nightfall, is to clamber to the top of the steep slopes of the hill on which the Observatory stands—in fact, to the paling of the enclosure—and then, joining hands in twos or threes, to bolt precipitately to the bottom, where, as may be imagined, they usually arrive "all in a heap." Hundreds join in this sport on fine evenings, and the result, as shown by the behaviour of the mercury, is to set the whole of Flamsteed Hill in a tremor, which does not subside until early next morning, many hours after the people have left.

Another very beautiful proof of this fact offered itself to me in the Geophysical Observatory of Rocca di Papa, Rome. A slight earthquake coming from Aquila (at 110 kilometres north-east of Rocca di Papa) was felt and registered by the instruments at 9.39 a.m. mean time of Rome, on the 8th of last February. Just at that time I was casually observing through a microscope a pendulum 6 cm. long, which suddenly began to display great agitation.

Now such a pendulum, when removed from its equilibrium position for an amplitude equal to the observed, comes to rest in about half-an-hour. In the present case the pendulum continued to oscillate till the afternoon. Nor did the character of the vibrations correspond to the gradually and regularly diminishing oscillation of a pendulum which has received a single shock.

The pendulum is firmly fixed to a big column, deeply founded



in the basalt-lava, so as to give trustworthy indications of the real movements of the ground. Perturbing causes which would have kept the pendulum in agitation, such as wind, the passing of people, carriages, &c., had not on that day to be taken into account.

I think it rather improbable that secondary and subsequent shocks, coming from the same centre as the first one, were the cause of the observed fact: a much more probable explanation would be that the whole hill on which the Observatory is built maintained during the whole time the particular state of trembling produced by the first shock.

Rocca di Papa, Rome, March 18.

EMIL ODDONE.

#### Striated Surface under the Cromer Drift.

AT the beginning of the present month (March) there were some good Forest Bed exposures in the neighbourhood of Cromer. Somewhat less than a quarter of a mile south-east of East Ranton, there was an exposure I had not noticed before. It consisted of a smooth, hard surface of ferruginous sand, not unlike some of our Trias beds, except that below it became softer. This slab of sandstone projected six yards obliquely from under the cliff, or rather talus in front of the cliff, with a slight dip to the west inwards, its outward face rising one foot above the sand of the foreshore. Upon the outer or longer exposed part there was no indication of striae, but toward the inner or more recently exposed portion faint grooves could be distinguished, becoming more distinct the nearer it approached the cliff; two feet from the cliff they were distinct and numerous. The main direction of striae ran due north and south, a few crossed from the north-west and north by east, but none deviated from the general direction beyond these points. They extended entirely across this part of the exposure, viz. 4 feet, and continued as far as the surface could be uncovered. Resting immediately above, as far as could be made out among the recent talus, was the highly-contorted drift sand and loam usually observed hereabouts; no flint nodules, stones, or boulders could be seen in them, and it is difficult to understand how these, if they had been present, could groove the bed so persistently in one direction when shoots took place.

About half a mile to the south-east and one mile to the north-west, the cliff sections this year show the soft sand and loam beds bent into anticlines, thrust back to a vertical position like a pack of cards on end, their central axes pointing to the north. This form indicates that the force came from the same direction as the mean striae engraved upon the underlying surface. Three points of interest will be observed:—

(1) That the ice which caused the striations could hardly have contorted the beds above them; it probably shrank back and allowed the drift to be deposited, and then encroached once more and contorted the overlying beds.

(2) Soft beds of sand and loam could not be twisted or contorted into ribbon forms unless a considerable load lay above to prevent them breaking up and becoming disarranged.

(3) We should hardly expect to find striae preserved upon a comparatively soft surface under what looks like bedded sand or loam; but unfortunately this point cannot be clearly established in consequence of talus obscuring the bed immediately above; but, bearing upon this point, it may be interesting to state during the summer of 1890 I found at Penrhyn, Nevin, Carnarvon Bay, a highly glaciated and striated rock surface which had been recently exposed. This *roche moutonnée* was overlain by a drift cliff of bedded sands and loams 100 feet high, resembling the Cromer drift in every respect except the contortions; these striations were from the east-north-east or seaward side also.

WILLIAM SHERWOOD.

Sutton Coldfield.

#### Pilchards.

IN this far-off corner of the world the news has only just reached me that my name has been quoted in your valuable columns with Mr. Cunningham's article on the growth of the pilchard or sardine. As it is a matter which much interests me, I should like to have a word or two on the subject. Personally, I have no doubt as to the identity of the pilchard and sardine. Seeing the matter has been so well threshed out by our greatest ichthyologists—Couch, Day, and Günther—the spawning of the fish being only a question of local conditions, and not

even giving us aid in determining the species—note the doings of the herring when about this work around the islands of Great Britain, which keeps shedding its roe for eleven months out of the twelve in these waters. As to the question of the English pilchard being so much larger than those of other countries, this to my mind is a subject of *grave doubt*, and I fear Mr. Cunningham's informants have not looked up the matter thoroughly.

When I was a juror in the London International Exhibition in 1883, in the Spanish department we gave awards to exhibitors who had pilchards of the same size and cure as those of Cornwall. Again, the principal markets for our Cornish pilchards are those of Italy. But in this business we are not alone, for side by side with our fish are the Spanish pilchards, cured like our own; generally they are a little smaller than ours, answering to our summer fish.

But in this past season they are decidedly our rivals, and in such quantities as to bring the price down in such a manner as to leave us with scarcely a margin of profit through their being just equal in size to our Cornish output.

In the past season we calculate that Cornwall and Devon have sent out about 25,000 casks of pilchards into Italy; but we should not be surprised to find that Spain has sent forwards into the same country over 30,000 casks.

We began the season by sending our fish forwards in September, and were rather surprised to find the Spanish merchants had glutted the Italian markets with fish in August, and the imports went on till near Christmas, which seems to indicate they were catching pilchards on the coasts of Spain in the summer and autumn of the year. When this question of the size of the pilchard has been fairly looked up, I think it will be found the size of the fish of any coasts will be chiefly governed by the facts that abrupt and exposed coasts, having a heavy sea and strong tides along them, will have the strongest and largest fish swimming in its waters; while the bays, and narrow and protected seas and inlets, will have the young, weak, and smaller fish in them, the nature of the foods having the lesser influence.

I have been led to believe the Bay of Douarnenez is the deepest bay on the coast of Brittany, and in it is carried on the largest fishery for young pilchards on the French coasts; while off the more abrupt parts of the coast of Spain the pilchards are large, like those on the exposed parts of Cornwall. And no doubt if the French coasts were well looked up, the same facts would come out respecting the fish there.

Fortunately for the French and Spanish fishermen, up to date they have not interfered with the food of the young pilchard; or, if they have, evidently they have substituted another in its room, viz. *cod's roe*; hence they have these little ones in their bays still; but we have driven out ours by starvation, as will be seen further on.

I was rather surprised to read Mr. Cunningham's statement when he said I had told him that I had never seen pilchards in Cornwall of the same size as the French sardines, for really I have seen millions just like them for size.

Possibly the error came from my misunderstanding his question, as we cannot see or get them now because of our altered conditions.

If Mr. Cunningham will consult F. Buckland's familiar history of British fishes (p. 109), he will see a letter from me confirming my statements, and written in the year 1872. In the year 1884 I received the medal of the Falmouth Polytechnic Society for exhibiting a series of small pilchards, showing their growth and ages in six stages—the smallest being less than an inch in length—up to the two years old full-grown pilchard.

Before the railway ran into our county, our bays were full of these little fishes in the summer months; and when our seines inclosed pilchards, the first question was their size, as pilchards under eight inches in length were useless for exporting purposes; consequently small fish were quickly turned back into the sea alive.

But sometimes, in the excitement and darkness of the night, the men were mistaken in the size of the fish, and took them into their boats; and when the daylight undeceived them the fish had to be carted off for manure. I have often seen them on our piers, piled up four feet high and hundreds of feet in length, waiting the waggons.

But all this has passed away, and we have not one pilchard seine left here to inclose pilchards should they again visit us. But their coming is very improbable, as the quantity of food necessary for their sustenance is so much diminished that if the



It will be found that the determinant is equal to

$$-(2 + c^2(k + K))^8.$$

Also

$$U - u + c\omega = -(U' - u' + c\omega'),$$

whence the condition of permanence becomes

$$\phi(u \dots u_3)\phi(U \dots U_3) = \phi(u' \dots u'_3) - \phi(U' \dots U'_3);$$

a condition which is satisfied when

$$\phi = m(u^2 + v^2 + w^2) + A\omega_1^2 + B\omega_2^2 + C\omega_3^2.$$

A simpler case of verification, involving exactly the same principles, is obtained by replacing the spheres by circular disks confined to one plane. Here there will be only 6 co-ordinate velocities,  $u, v, \omega, U, V, \Omega$ , and the notation may be preserved as before, only

$$\omega = P\Omega + \rho\omega, \quad K = \frac{P^2}{A}, \quad k = \frac{\rho^2}{A};$$

and neglecting  $v$  and  $V$ , the velocities resolved in the tangent, as before, we have, now, the factor multiplying the determinant reduced to  $\frac{1}{(2 + c^2(K + k))^4}$ , and the determinant to 4 rows and columns instead of 8, which will readily reduce to

$$-(2 + c^2(K + k))^4.$$

There is, therefore, really nothing *vague* in Boltzmann's treatment: all that it does is to show on general dynamical principles that the functional determinant must be unity in all cases, and therefore avoid the labour of evaluation.

What has been thus done for the collisions of heterogeneous spheres and circles may be equally well done by the application of the Boltzmann method to colliding systems of any number of degrees of freedom; it will be found that there is no vagueness in the process, although, of course, the analytical difficulty may be greatly increased with the circumstances of different cases. And what I understand to be the meaning of the Boltzmann-Maxwell law of partition of energy will, I believe, be found to be true in each case. I understand that law to assert that when the kinetic energy of each system has been expressed, as it always can be, as the sum of  $n$  squares, as  $P_1^2, P_2^2, \dots, P_n^2$ , each of the  $P$ 's being a linear function of the  $n$  generalized velocity components, the average value of each of these squares is the same in the special or equilibrium state. For example, where the system is a single rigid body with 6 degrees of freedom and twice the kinetic energy is

$$M(u^2 + v^2 + w^2) + A\omega_1^2 + B\omega_2^2 + C\omega_3^2,$$

the average kinetic energy in the special or equilibrium state contributed by each translation is  $\frac{1}{2}$  of the whole, and the average kinetic energy contributed by each rotation component is the same. It does not appear to me that the law asserts more than this, or that any application that has been sought to be made of it requires anything more than this.

These conclusions are confirmed by Mr. Burbury in the paper to the Royal Society already mentioned, and by an entirely independent treatment.

I have purposely limited myself to the consideration of colliding elastic systems treated by the conventional laws of impact, because one such case had been specially singled out in the British Association Report, and I believe that in all such cases the Boltzmann-Maxwell law of partition will be found to hold good. The most general cases contemplated by Boltzmann and Maxwell, involving the considerations of forces between parts of the molecules themselves, with continued interchange of Kinetic and Potential Energies, as well as intermolecular and external forces, demand further space than could reasonably be asked of you.

H. W. WATSON.

Berkeswell Rectory, Coventry, March 21.

### The Functions of Universities.

As it is most desirable that students of all classes should, as far as possible, be in contact with one another during the impressionable years of training, it is eminently desirable that schools of engineering should be connected with Universities. It is distinctly contrary to public policy that the present denominational education of students of different professions in special seminaries, whether they are ecclesiastical, or medical, or engineering, should be encouraged. The existing separation of professional and commercial education is most mischievous, and

is very largely due to compulsory Greek. Anent this, all that I said was that the danger of a Pagan revival was the *best* argument for compulsory Greek; I did not say it was a *good* argument. About going to Colleges and Universities, I did not say that the student should go to a College and *not* to a University, if he ever had time and ability to benefit by University training. Very few can do this, hardly any undergraduates ever do; and what I deprecate is that University Professors should be expected to waste their time in making cripples run—that is what College teachers and private coaches are paid for doing. Some Universities, as, for example, that of Dublin, are too poor to pay double sets of teachers, but that is their misfortune, and should not be a precedent for a rich country like England, nor for the wealthiest city in the world, like London.

As to Prof. Ayrton's forgetting the debt due to those who studied useless subjects, I chide him for it because he sneered at useless subjects. If he still sneered at useless subjects, I would chide him still, even though he wited his prophets' sepulchres by using the whole scientific hierarchy to name his units after. As to my forgetting the debt due to the practical applications, my letter was too short to include everything in it.

Anyway, I entirely agree with Prof. Ayrton that the business of technical schools is to teach *useful* knowledge, and further, that the enormous majority of mankind are most fortunately employed in doing useful things, and should not be asked to waste their time on trying to do useless ones.

GEO. FRAS. FITZGERALD.

### A New Comet.

In last week's NATURE (p. 484) I announced the discovery of a new comet on March 18, and an editorial note was appended to my letter as follows: "This is stated to be Winnecke's comet." Will you kindly allow me to point out that this statement is based on a misconception, for the two comets alluded to are situated in widely different regions of the sky, and cannot possibly be identical, as a comparison of the following positions will show:—

March 18, 1892.

	R. A.	Decl.
Winnecke's Comet	191°	+ 31°
Denning's Comet	341	+ 59

Bristol, March 26.

W. F. DENNING.

P.S.—The following is an ephemeris of the latter comet computed by Dr. Birdschof for Berlin midnight:—

	R. A.	Decl.	Light.
	h. m. s.		
March 29	23 49 2	+ 60 32	1'01"
April 2	0 13 50	+ 60 39	1'00"
6	0 38 8	+ 60 34	1'00"
10	1 1 37	+ 60 18	1'00"
14	1 24 4	+ 59 52	1'00"

The comet reaches its perihelion on May 12.

W. F. D.

### ON INSECT COLOURS.

#### I.

THE Editor of NATURE has been so kind as to invite me to give in these columns a short summary of certain investigations that I have been for some time past engaged in, upon the behaviour of various insect colours when tested by chemical reagents. A full account of these experiments, of the methods of working, and of the reagents used, has been published in the *Entomologist*,<sup>1</sup> to which journal I must refer my readers for any details that they may desire. Here, space will allow me only to give in a condensed form the broad results. It is necessary to say, however, that the remarks in this article have reference only to the colours of the Lepidoptera; and, further, of the *imagines* only. The experiments have been made by immersing the wings for *one hour* in the following reagents: strong hydrochloric acid; 50 p.c. nitric acid; 45 p.c. sulphuric; strong acetic; strong ammonia; 25 p.c. potassic hydrate; and 10 p.c. sodic hydrate.

<sup>1</sup> April 1890 to September 1891.

First of all, I must draw attention to a very important distinction between colours and colours. It is, of course, clear that a colour may be due either to a pigment or to the physical structure of the coloured body; and it was therefore very necessary for me to find out, so far as possible, which of the colours I might have to deal with were physical, and which pigmental. With regard to some of these, it could tolerably safely be conjectured—merely from the appearance—that they were simple physical colours; in such cases, I mean, more especially, where there was a distinct *sheen* or glow in the colour; and I have been able to confirm various conjectures that had previously been made, both by others and myself, as to these physical colours. But in many other cases—indeed, in the majority—nothing but experiment could decide the question; and in some instances the decision has been as unexpected as disappointing to me. In order now to classify the results that I had obtained, and to introduce as much order and method as possible into my explanations of them, I have already ventured to propose<sup>1</sup> the following scheme of colours: (1) pigmental colours; (2) interference colours, which include a very large number of insect examples, besides, of course, the iridescent colours displayed by the wings of dragon-flies, May-flies, &c.; (3) *reflection* colours, other than the interference colours—these will be found to include all the white-winged species that I have examined; and (4) it seems necessary to have a class of simple *absorption* colours, in order to include all those cases of black in which no pigment can be found, but, apparently, all the light-rays are absorbed in a dense coating of scales.

The limits of space at my disposal compel me to pass over the colours black and white with the remark that as to the former, with one or two dubious exceptions, it can be affected by no reagents, and I have, therefore, concluded it to be not pigmental, but simply a "physical" absorption colour; full details as to this will be found in the *Entomologist*. As to white, I have similarly failed to find any pigment, or to obtain any reaction, except with *Melanargia galathea*, and two or three white-fringed species; in these instances the white is changed to a *deep yellow*, which presently dissolves in the reagent. The explanation of this I must defer until the phenomena of yellow have been discussed. For the rest, white is evidently simply a reflective colour, and not pigmental.

We now have to consider in succession the five colours blue, green, red (and pink), yellow (and orange), and chestnut; and, first of all, I must recur to what was said above on the criteria of physical and pigmental colours. Referring my readers to the condensed tables of results, given at the end of this article, I think—as the results of what I have been able to learn from my experiments—that the following rules may be laid down. There are certainly two ways in which a pigment colour may be affected, and either effect is conclusive evidence of the presence of a pigment. Firstly, the colour may be dissolved out; the liquid is left more or less deeply coloured, and the wing is *white*, or colourless.<sup>2</sup> This is the case (*vide* tables) with all the yellows and chestnuts that are sensitive at all to the reagents, and also with the pigment greens in most instances. It is very important to observe that this change from a yellow or chestnut wing to a white one does *not* imply any change from a yellow pigment to a white one—as might at first be supposed from merely glancing at the records in the tables: it is not so. The change is due simply to a solution of the pigment, which has originally been developed, *not from a white pigment*, but in a white, *i.e.* previously unpigmented, wing. It will be necessary to refer to this again later in discussing the behaviour of *A. galathea*. It is scarcely necessary to point out how important a bearing the inter-

pretation of such results has upon our view of the nature of white.

To proceed: the second criterion for pigment colour (and this, it is needless to say, cannot concur with the former) is what I have denominated the "reversible" or "reversion" effect; and this I have found only in the case of red,<sup>1</sup> which, I may observe, is out and away the most satisfactory colour to experiment upon. In these cases, the effect of the reagents (but chiefly of the acids) is to convert the red colour into a fine yellow or orange, from which the original red can be completely recovered by appropriate means, as will be explained in due course: here, again, there is indubitably a pigment in evidence. In some cases, however, where there is neither solution nor any "reversion" effects, but yet a (sudden) change from the original colour, it is extremely perplexing to decide whether we have to do with a pigmental or with a physical colour. Instances of this will be found in the tables, among the greens (*e.g.* *Argynnis* and *Thecla*) and the blues (*e.g.* the *Lycaenidæ*). In such cases I have not ventured to pronounce definitely in favour of either view, although it appears to me that the evidence is strongly in favour of such colours being simply physical.<sup>2</sup> I do not think that there is the least difficulty, theoretically, in supposing such reactions to take place with mere physical colours; since the wing-surface, when soaked—even by an indifferent or neutral fluid—might well be so affected, at least temporarily, as to alter its reaction in the light rays, *i.e.* to alter the resulting colour. In such cases, then, we have an element of doubt to contend with.

Then, as to undoubtedly physical colours, there are certain blues and greens which, when examined with the naked eye even, can be seen to be, not a continuous patch of colour, but a mass of—so to speak—distinct dots. Speaking now on the strength of my experience with such, I think I am justified in stating that these may safely be pronounced off-hand, without experiment, to be physical. When such colours are tested with the reagents, they may either be entirely unaffected, or the colour may disappear, but reappear (usually quickly) on drying. It may *prima facie* be retorted, and not unreasonably, that these should be considered pigment colours showing the reversion effect; but—as will be seen after the reversion effect of red has been described—there is really no similarity at all; and there can scarcely be a doubt that these are merely physical colours.

Again, a brilliant metallic-looking colour may be changed to a different colour, or sometimes to a dead brown or blackish (*vide* tables: green), and this effect may be either temporary or permanent; and yet, from the general appearance of the colour before and after the experiment, one may feel thoroughly assured that it is only a physical colour.<sup>3</sup> And lastly, in such cases, a brilliant blue, *e.g.*, may be unaffected by most reagents (or only temporarily so), whilst such a reagent as nitric acid or potassic hydrate may permanently dull or destroy the colour. This is perfectly intelligible, since in such cases the powerful reagent has no doubt damaged the surface structure. I have thought it only right and fair thus to outline the data on which my conclusions concerning the nature of these colours have been founded,

<sup>1</sup> One or two instances have recently been noticed of partial reversion of a colour originally reddish-brown among the Bombycines. These seem to be connecting-links between yellow and chestnut descended colours (see later).

<sup>2</sup> Facts in support of this view will be quoted in their proper place. But I may be allowed to say that one's judgment in such cases must be *partially* founded on observation of appearances and conditions that in their nature do not admit of being described or formulated, but appeal to an observer who has learnt by experience to interpret such indications. It will therefore be understood that, throughout this article, the actual evidence for my conclusions is apt to be somewhat discounted when the attempt is made to briefly convey it in words.

<sup>3</sup> I ought to add that it is *not* always safe to assume, merely because the reagent has become coloured, that the surface colour under examination is a pigment colour; for some recent observations have led me to believe that there may be an unapparent pigment present in wings whose surface is physically coloured only.

<sup>1</sup> *Entomologist*, September 1890.

<sup>2</sup> The apparent exceptions of *Vanessa io* and *V. atalanta* will be explained under "chestnut," *infra*.

although feeling that it is very difficult indeed to convey, merely by a brief verbal definition, the practical distinctions that one has slowly learnt from experience to recognize. We will now take each of the colours in detail, although, after this general account of the behaviour of physical colours, there is not much left to say of blue, or even of green.

If now the tables of results be referred to, it will be seen that I have arranged the blues in five different groups; but the differences between the first three—or probably four—are so slight that they might almost as well be thrown together. It is, however, somewhat convenient to consider them apart. In the first group the blue is a magnificent velvet blue, with a rich glow. *Primá facie*, it is evidently a physical colour (as Wallace, e.g., had pointed out years ago), and its behaviour when tested with reagents leaves no doubt of this. Reagents either are without effect, or cause a temporary dulling which disappears on drying, or plainly and permanently injure the wing, and destroy the beautiful glow or even the colour entirely. In cases of merely temporary dulling, where the full colour returns on drying, I believe that the effect is due simply to the soaking of the wing, and that neutral liquids would produce the same effect. The second group, after the explanations I have already given and the information that I have tabulated, requires very little comment. The various reactions abundantly showed that all these are simply physical (interference) colours. The third group are hardly distinguishable from the second: the behaviour of the blue on *P. machaon* when wetted with a reagent and then dried, is an excellent example of such physical colours as were referred to above. Now, concerning the fourth group, which in all probability should be considered as one with the three foregoing. I presume that most people are familiar with our beautiful and common *Vanessa* butterflies, the "Peacock," "Admiral," and "Tortoiseshell," and know that the borders of the wing are marked in the two latter (as well as in the "Camberwell Beauty") with spots of blue, while in the "Peacock" there are magnificent blue ocelli. The position of many of these marks strongly reminded me of the special positions of blue in various flowers;<sup>1</sup> and at the commencement of my experiments I was in great hopes of discovering a blue pigment in these *Vanessæ*; but after repeated experiments I was driven to conclude it almost certain that the blue here is simply physical. Its reactions throughout indicate as much; since, on being treated with the reagents, it either is wholly unaffected; or it disappears, but returns on drying; or it pales to a sort of grey that resembles the effect produced in the species of the third group; or lastly, it may in some cases disappear entirely, as I have already pointed out that some physical colours may. Finally, we have in the fifth group, containing the little blue butterflies of the family *Lycenidæ*, the only instance I have found of a blue not certainly physical, and even here the evidence is, I think, in favour of a physical colour. The question, however, is an unusually perplexing one; and for a long time I supposed that these were pigment blues, but I am very doubtful about them now. There is no solution, and I have no evidence of any reversion effect; the colour is changed certainly, and it is rather significant that in several of the deeper coloured species the artificial colour thus obtained is nearly identical with the normal colour of *P. corydon*; but such changes in no way preclude the colour being physical. The fact, too, that in several instances the effect was to produce a green or greenish tint now appears to me very suspiciously indicative of a physical colour (cf. *Papilio polyctor* in group 2). I may add, too, that the reaction of the green in the closely related "Hairstreak" butterfly, *Thecla rubi*, which I think is in all probability physical, must also be taken into account; for the reaction

in that instance is similar in general character to that of these blues.

To sum up, then, the case for this last group of blues, it seems to me that we cannot certainly conclude them to be physical, but the evidence points very strongly to the view that they are—like the other blues—physical and not pigmental. Should this conclusion be correct, I have as yet found no instance of pigmental blue among these Lepidoptera.

We will now pass on to green. It will be seen that in the tables I have divided green into three groups; of these, the first are unmistakable physical colours, exactly analogous to the group of metallic blues, and it is therefore unnecessary to comment further on them. The second group, though not metallic, are nevertheless, I believe, also simple physical colours. Not only can I say of them what was said of the blue *Lycenidæ*—that there is not the slightest evidence for any pigment; but I may go further, and say that there is some evidence for the green being physical. The striking characteristic of this group is that every reagent *instantly* turns the green to a brown or bronze brown,<sup>2</sup> which reaction might, as far as it goes, equally betoken either a pigment colour of the "reversible" nature, or a mere physical colour. That it is of the latter nature is indicated both by the fact that I have observed, no true reversion effect (always defining this reversion effect by the standard example of red), and also since it is possible to produce a similar, though only temporary, transformation by pure water or by alcohol. This, I think, makes very strongly indeed for the colour being simply physical, loth as I am to recognize that the magnificent and interesting greens of such species as the *Argynnis fritillaries*, and *Thecla rubi* are impigmental. Still, my final conclusion, after prolonged and careful consideration, is that these colours are simply physical.<sup>3</sup>

Coming now to the third group of greens, we have here undoubtedly pigment colours, showing the solution effect. There are various degrees of solubility among them, and a varying sensitiveness to different reagents; but the summary, in brief, is that the green pigment is dissolved out, leaving a white, i.e. unpigmented, wing. Here, again, I need merely repeat what has already been said of yellow, and will again be referred to, viz. that the (green) pigment has been developed, *not from a white pigment*, but in a white, i.e. unpigmented, wing. A further question, however, arises—whether green has been directly evolved as such, or is a second stage in the coloric evolution. If the table be examined, it will be found that in several cases the green has been transformed to yellow or yellowish; and this has occurred too commonly to be otherwise than significant. I am therefore of opinion that green has been evolved from yellow, and that the production of yellow in these cases under the influence of the reagents is a retrogressive metamorphosis comparable with the production of yellow from red. The evidence admittedly is not anything like so conclusive or copious for the inference of this derivation of green, and I should, perhaps, hardly have advanced this view but for the analogy to the standard behaviour of red. As it is, however, it seems to me incumbent to hold—at least provisionally—that these pigment greens have been evolved from yellow.<sup>3</sup> It is, however, very evident—as will appear from the following discussion—that the respective relations of green and red to yellow are very different indeed, although there be a community of descent. It may be well to point out also that these greens occur in three very different groups of the Macro-Lepidoptera, viz. in the Rhopalocera, the Noctua, and the Geometra. The apparent exception of *Cidaria* will be referred to later; it

<sup>1</sup> It is especially interesting that in *T. rubi* this brown is the same as the usual ground colour, constituting the greater part of the wing surface.

<sup>2</sup> A discussion in somewhat greater detail of this group—indeed, of the greens in general—will be found in the *Entomologist* for May 1891.

<sup>3</sup> Cp. also *Entomologist* for May 1891.

<sup>1</sup> Vide, or instance, Grant Allen's "Colours of Flowers."

is just possible that in these species the green is descended from, not yellow, but chestnut.

Quitting the greens,<sup>1</sup> we now come to what is out and away the most satisfactory and interesting colour that I have studied—that is to say, red. Owing, however, to the very intimate relations of this colour to yellow, it is difficult to discuss them apart, and we will therefore take yellow and red together. Referring, now, first of all to the table of reds, what do we find as the general result? Omitting for the present (since they must be considered later) the last four species, we find that in practically every instance red is (rapidly or *instantly*) changed by acids<sup>2</sup> to some kind of yellow or orange; or, to state it in terms of the views that I have been led to adopt, red is retrogressively modified into the yellow from which it was originally evolved.<sup>3</sup> Here, however, the change stops; for, with the one striking and interesting exception of *Delias* (and perhaps one might add one or two of the pale pinks occurring among the Spingides), the yellow thus produced is *immovable*. And since the species experimented upon include all varieties of red, and represent all the groups of Macro-Lepidoptera, one might apparently conclude that, although red is an exceedingly sensitive colour, yellow can never be affected. Yet, if the table of the *normally* yellow species be examined, it will be found that, in an immense number of these, the yellow is either partially or wholly dissolved by various reagents, leaving a pure white wing. Here, therefore, we find ourselves at once face to face with the problem of the character of the yellow pigment, and to a consideration of that we must turn before proceeding further with red.

It will be observed that in this table of yellows I have divided the species examined into four groups. Omitting for the present the small second group, we may distinguish three stages, represented by the three groups 1, 3, and 4.<sup>4</sup> This division has been adopted in order to illustrate what seems to me the most feasible explanation—at least for the present—of the constitution and behaviour of this yellow pigment. In the first group the yellow is exceedingly soluble, and a colourless white wing is the result. In the next stage (the third group) the yellow is more or less affected—sometimes very little moved, sometimes finely dissolved. In the last group the yellow is *wholly insoluble and entirely unaltered*. Also be it noted that in group 1 pale light yellows predominate, while in the last group the yellow is chiefly orange. It is, further, clear from this that a complete classification of all the yellows would include in this fourth group all the yellows artificially produced by reacting on the reds. Now, the explanation which I have adopted in order to cover all these facts is as follows. It appears that the yellow pigment, when first<sup>5</sup> evolved, is exceedingly sensitive and susceptible of evolution by various reagents; in this stage, too, it is probably of a comparatively pale or light yellow colour. In course of time the yellow pigment may in various instances become slightly altered in constitution (generally accompanied by a change to a deeper or more orange tint), and altered in the direction of *greater stability*; or rather, to confine ourselves to the literal facts, altered to the extent of becoming far less soluble. Of this intermediate stage we have examples in group 3. Finally, in group 4 we have examples of the last stage of evolution, when an—usually

<sup>1</sup> I have not thought it worth while to refer here to the pseudo-green of *Euchloa cardaminus*: vide *Entomologist*, May 1891.

<sup>2</sup> It is unnecessary here to regard the less marked and less interesting alkaline reaction.

<sup>3</sup> Some remarks on this subject will be found in the *Entomologist*, xxiii. 370-71.

<sup>4</sup> It is, of course, to be understood that, like all rigid divisions, this is to some extent artificial. Evidently Nature knows nothing of three or four sharply-circumscribed groups of yellow, but merely an ind finite series, of which the first members would fall into my first group, and the last into my fourth, and so on.

<sup>5</sup> I speak, of course, in a phylogenetic sense.

deep-coloured—insoluble yellow has been evolved. It appears to me, therefore, that *usually* red is evolved only after a long apprenticeship of yellow, and this is as much as to say that as a rule the yellow has become stable and insoluble before its evolution into red: this explains why red can be converted into yellow, but usually *no further*. On the other hand, the striking instances of *Delias* and one or two pink species show that occasionally the development of red has been so rapid that the yellow had not previously become stable.<sup>1</sup> The very parallel examples of *Cardaminus edusa* and *Lycena phloas* and *virgurea* should be compared with these.

There is, however, still in my mind an open point as regards several of the yellow species in the last group; for it is not clear by any means that we may not have included here one or two *physical* yellows as well. We know that the yellows of the first three groups are entirely pigmental, for their solubility shows this; and we know that in the fourth group several species, such as *Deliopeia bella*, *C. hera* *lutescens*, *A. villica*, are pigmented, since their relations to red species which yield a similarly insoluble yellow proves this; but in the case of, for instance, *T. pronuba* (the "Yellow Underwing") and its miniature analogue *Heliaca*, we are totally in the dark; and it appears safer to me to withhold for the present any opinion as to whether these be physical or pigmental yellows. Were there any red underwing in the same genus as either of these, that would be sufficient to justify us, by analogy, in considering the yellow of these species pigmental, just as we do that of, e.g., *Arctia villica*; but failing such evidence, the experimental evidence is not decisive in either direction.<sup>2</sup> There is, however, a most remarkable and exceptional set of phenomena connected with these yellows that I once thought might prove the criterion by which to distinguish between pigmental and possibly physical yellows in doubtful cases such as that of *T. pronuba*. Some time ago it was incidentally observed by Mr. Edwards that the wing of a species of *Colias* left in a damp cyanide bottle *was turned red*. This statement was brought under my notice by Mr. T. D. A. Cockerell, first of all in the columns of the *Entomologist*, and later in a private communication. I must frankly admit that for a long time I remained entirely incredulous of this alleged fact, since it was utterly opposed to all my own experience. I had observed nothing but *retrogressive* modifications of colour, whether by solution or simple change, and had found potassic cyanide (in solution) to rapidly dissolve the yellow of *Colias*, leaving a simple white wing: it was therefore very difficult to credit such a statement.

I will not trouble the readers of NATURE with any detailed account of my experiments<sup>3</sup> in this direction, made with the purpose of verifying—or otherwise—the correctness of Mr. Edwards's statement; but will simply say that I finally succeeded (owing really to a lucky accident) in verifying this. A yellow wing of *Colias* placed on *wet* cyanide is turned red, in spite of the solvent action of the cyanide: such an effect could never be attained by using a cyanide *solution*, because all the yellow would be dissolved out of the wing in a very short time; it is therefore necessary to hit the happy medium between dry cyanide and solution: as it is, a good deal of the yellow always goes into solution, but sufficient is left in the wing to be reddened. I have not stopped, however, at *Colias*, but have examined a number of other yellow species, with the result that I find many yellows become changed by this method to a really brilliant red

<sup>1</sup> See a full discussion in the *Entomologist* for January last.

<sup>2</sup> It is, however, to be noted that in one case I found the yellow of *T. pronuba* very faded; but I do not care to contend for a pigment on the strength of this alone.

<sup>3</sup> An account of these will be found in the *Entomologist* for July 1891. I hope that I have made it sufficiently clear that I have no shadow of a claim to any credit in discovering this extraordinary phenomenon. Most certainly I should not have found it out: in the course of my own experiments, or even afterwards but for Mr. Cockerell's insistence on the accuracy of his statement.

—which red seems indefinitely permanent if the wing be removed and dried. It will be seen that, in the table of yellows, several species are marked as showing the "cyanide effect"; whilst others are marked "no cyanide effect." The former are those in which I have succeeded in obtaining the reddening; the latter will not redden. Now, since the former are all known to be pigmental yellows, whilst one of the latter, viz. *T. pronuba*, is the doubtful case, it seemed probable that this cyanide reaction might take place *always and only* with pigments, and thus afford the desired criterion. But in extending my experiments this hope proved fallacious, for I found—as is noted in the table—that various pigment yellows gave no reaction: the typical case on which I relied was *C. hera lutescens*: had this yellow, which is assuredly pigmental, although quite insoluble, been reddened, I should have felt justified in accepting the criterion. But not the slightest reaction took place with this species. I must not linger longer on this certainly fascinating subject: it is clearly one that requires thoroughly working out, and my investigations thereupon, are being carried on in several directions; but I may point out the great interest attaching to a reaction by which we can produce a coloric change practically identical (at least in its effects) with that which progressive evolution has produced in many species formerly yellow but now red.

Before, however, quitting yellow, there are one or two points yet that need explanation. In group 2 in the table, I have included two species showing a rich orange colour: this, though clearly marking a considerable progress in coloric evolution from the presumably primæval pale yellow, is yet *exceedingly soluble*: these instances, which, therefore, are very comparable with the red of *Delias*, are another proof that advance in depth and richness of colour is not necessarily always accompanied by decreasing solubility. I may add that I do not regard the orange of these two species as being in the direct line of evolution from yellow to red, but rather as a collateral or branch line also springing from yellow.<sup>2</sup> It is specially interesting that in this circumstance, as also in so many others, there is an exact parallel among the chestnuts.

And lastly, among the phenomena of yellow, we have to deal with the reaction of *Argia galathea*, already referred to; a reaction in which, contrary to all other experience, a white wing is changed to yellow by various reagents. It is very evident that, since I deny the existence of any pigment in white wings, and assert the yellow to have been developed in a previously unpigmented wing, and not by evolution from a white pigment, it is all-important for me to clear up this matter. My explanation, which has been given in some detail in the *Entomologist* (xxiii., pp. 341-43), is—to be as brief as possible—the following. It is, of course, well known that the pigments of both animals and plants are decomposition products of the protoplasm, whether produced directly by decomposition of the protoplasmic molecule, or indirectly by union of two or more decomposition products. Now, I take it that in this species—*A. galathea*—the metabolic processes have not yet produced any pigment, *but very nearly so*; that there exists in the wing a very unstable *mother-substance* (itself a decomposition product, whether produced immediately from the protoplasmic molecule, or indirectly from a molecule of intermediate complexity); and that the action of any powerful reagent is to decompose this, forming the yellow pigment; which pigment, as soon as formed, commences to dissolve in the reagent, as so many normal yellows do.<sup>3</sup>

<sup>2</sup> I have also obtained it with *Loxura heteromus*. It is very significant that I have in no case obtained it among the *Heterocera* (moths), but only among the *Rhopalocera*. Cf. *infra*, on chestnut.

<sup>3</sup> It is very interesting that the orange of *C. cleopatra* first of all is changed to the ground yellow, and then dissolved.

<sup>4</sup> I may point out that in the female of *A. galathea* there is already a cream tint in the wings.

This view, although at present necessarily somewhat hypothetical, appears to me to offer a satisfactory explanation of the apparently anomalous behaviour of *galathea*.

F. H. PERRY COSTE.

(To be continued.)

#### NOTES.

MR. ALFRED RUSSEL WALLACE AND MR. EDWARD WHYMPER are to receive the Royal Medals of the Royal Geographical Society at its annual meeting on May 23 next. The annual dinner of the Society will be held on the evening of that day after the annual meeting. The annual *conversazione* will take place about the middle of June in the South Kensington Museum.

MR. CHARLES HOSE, Resident on the Baram River, in the Rajahship of Sarawak, has recently explored that river to its sources, and ascended Mount Dulit, one of the summits of the main range which traverses this part of Borneo, to a height of 5000 feet. His zoological collections, which have been forwarded to the British Museum, contain many fine novelties. Among the mammals, which were described by Mr. Oldfield Thomas at the last meeting of the Zoological Society, are representatives of a new Carnivore of the genus *Hemigale*, two new Insectivores of the genus *Tupaia*, and a new Squirrel. The birds, which are being worked out by Dr. Bowdler Sharpe for *The Ibis*, likewise contain several remarkable new forms, amongst which is a new species of the restricted Eurylæmine genus *Calyptomena*, intermediate in size between *C. viridis* and the large *C. whiteheadi* of Mount Kina-balu. Mr. Hose is a nephew of Dr. G. F. Hose, the Bishop of Singapore and Labuan.

AMONG the names attached to the recent protest of members of the corporation and teaching staff of University College, London, against the Gresham Charter, we notice the following representatives of science and Fellows of the Royal Society:—Sir F. Abel, Prof. I. B. Balfour, Sir Henry Bessemer, H. S. Caxter, Sir J. N. Douglass, W. T. Thiselton-Dyer, Prof. W. H. Flower, Prof. E. Frankland, Dr. George Harley, R. B. Hayward, H. Huddlestone, Prof. T. H. Huxley, Prof. E. Ray Lankester, Prof. Norman Lockyer, Prof. O. J. Lodge, Sir John Lubbock, Prof. D. Oliver, Prof. J. Prestwich, Prof. G. J. Romanes, Sir Henry Roscoe, Prof. Burdon Sanderson, J. Wilson Swan, Prof. Sylvester, E. B. Tylor, and Prof. W. F. R. Weldon. The protest contained equally influential names in the fields of literature, art, and politics; thus forming a document having no small weight in the final decision of the Government regarding this futile attempt to solve the problem of a Metropolitan University.

WE regret to have to record the death of Sir William Bowman, F.R.S., the eminent ophthalmic surgeon. He died of pneumonia at Joldwynds, his house near Dorking, on Tuesday last. He was born on July 20, 1816. In 1840 he was elected assistant surgeon at King's College Hospital, where he afterwards became full surgeon. He was also for a time assistant surgeon, and then full surgeon, at the Royal London Ophthalmic Hospital. He acted as the first president of the Ophthalmological Society of Great Britain, which he helped to found; and in 1884 he was created a baronet in recognition of his professional eminence. Sir William was a master of the various methods of ophthalmic surgery, and did much to improve them and to place them on a sound scientific basis. He held a leading place among those who made accessible to English students the knowledge obtained by the invention of the ophthalmoscope; and to him belongs the honour of having overcome the hostility

with which Von Graefe's operation of iridectomy for the cure of glaucoma was received by some authorities in this country. He also devoted much attention to the treatment of obstructions of the tear passages, and to improvements in the operation for cataract. His microscopic work, so early as 1840, was recognized as work of high value. He was elected a Fellow of the Royal Society in 1841, and received one of the Royal Medals in 1842. He was a member of many other scientific Societies both at home and abroad, and honorary degrees were conferred upon him by the Universities of Cambridge, Dublin, and Edinburgh.

DR. R. THORNE THORNE, F.R.S., will succeed Dr. George Buchanan, F.R.S., as medical adviser to the Local Government Board.

PROF. LODGE has, with the approval of the Senate, appointed to the demonstratorship in electrotechnics at University College, Liverpool, Mr. Francis Gibson Baily, late Scholar of St. John's College, Cambridge. Mr. Baily took first-class honours in the Natural Science Tripos, and is now in the employ of Messrs. Siemens Bros. and Co.

THE *Revue Scientifique* notes that at Kieff there is a chemist who is nearly as old as the late M. Chevreul was at the time of his death. This is Prof. Ignace Vonberg, who was born at Vilna on January 17, 1791. He was one of the last Professors of Chemistry at the old University of his native place, and afterwards held, until 1866, a similar position at the University of Kieff. He is said to enjoy excellent health.

It has been decided, according to Norwegian newspapers, that Dr. Nansen's North Pole Expedition shall start on January 1, 1893. He has selected as members of the Expedition a young officer in the Royal Norwegian Navy, Herr Sigurd Scott-Hansen, who will make the astronomical observations, an experienced Arctic navigator, Captain J. Ingebrigtsen, from Tromsø, and Herr Sverdrup, by whom Dr. Nansen was accompanied in his journey across Greenland.

EVERYONE who occasionally visits the Zoological Gardens was sorry to hear of the death of the giraffe. Since May 24, 1836, the Gardens have never until now been without one of these interesting animals. Dr. P. L. Sclater, writing to the *Times* on the subject, says that during the past fifty-five years there have been in the Gardens thirty giraffes, of which seventeen have been bred and reared there. A male born on April 22, 1846, lived in the Gardens nearly twenty-one years. These facts prove, as Dr. Sclater says, that this animal (one of the most extraordinary forms among recent mammals) is quite fitted for captivity, and is well worthy of the expense and trouble incurred in its keep. The closure of the Soudan by the Mahdists has prevented the importation of giraffes for some years, and for the only individual now in the market (an old female) a prohibitive price is asked. The Zoological Society hope that the need may be supplied by some of their friends and correspondents in Eastern or Southern Africa.

DR. B. W. RICHARDSON will deliver at the Royal Institution his Friday evening discourse on "The Physiology of Dreams" on April 29, in place of Dr. William Huggins, who will give his lecture on "The New Star in Auriga" on May 13.

PROF. W. G. OWENS writes to us from Bucknell University, Lewisburg, Pa., U.S., that on March 15, at 2 o'clock p.m., a series of halos and parhelia appeared and increased in brilliancy until 4 o'clock, after which they faded gradually till sunset. The circles, arcs, and spots around the sun were highly coloured, sometimes showing almost the entire spectrum.

THE Report of the Meteorological Council for the year ending March 31, 1891, has recently been issued. The follow-

ing changes relating to organization were under consideration during the year: (1) the purchase of a new house near Cahirciveen, to which it is proposed to move the Observatory from the island of Valentia, the former place being more suitable for observations; (2) the registration of the Council as a corporate body, under section 23 of the Companies' Act, 1867; (3) examination of clerks, keeping as far as practicable to the system followed in the Civil Service. The practice followed by the Office with reference to observers at sea remains unchanged. The number of voyages for which logs have been returned during the year was 156; instruments have also been supplied to various islands in the Pacific, &c. In the weather forecasting branch, a comparison of the forecasts issued at 8.30 p.m. during the year with the weather actually experienced, shows that the total percentage of success was 82. The results were best, 83 per cent., for the south of England, and worst, 77 per cent., for the south of Ireland. The hay harvest forecasts were very successful; as much as 95 per cent. of success was attained in some parts. To add to the means of obtaining warnings of stormy weather at exposed fishery stations, the useful practice of lending trustworthy barometers, adopted by Admiral FitzRoy, has been continued; the number of stations now supplied is 180. The subject of cloud photography has continued to receive attention, and the system of observation and reduction has been improved, so that there is reason to expect that satisfactory determinations both of the heights and the velocities of the various clouds will be made. The Council have requested Mr. W. H. Dines to carry out a series of experiments at Oxshott for the purpose of comparing the action of various forms of anemometers, as well as experiments on the resistances of curved plates and vanes. The work is nearly finished, and the results will be published.

THE *Deutsches meteorologisches Jahrbuch*, Bavaria, 1891, Heft 3, contains twelve cloud pictures, reproduced from photographs supplied by Hildebrandsson, Riggenbach, and others. These photographs have been collected by Dr. Singer, of Munich, who submitted some of them to the International Meteorological Conference held there last autumn, where the importance of the artistic representation of clouds was discussed. The Cloud Atlas, published at Hamburg in 1890, was recognized by a large majority as the first satisfactory attempt to obtain uniformity in cloud nomenclature; but a Committee was framed to further consider the future production of pictures in a cheap form, according to the types approved by the Conference, and Dr. Singer was asked to join that Committee. The pictures now in question may be considered as his contribution to the subject. The forms are well defined; the names proposed differ materially from the classification by Luke Howard, hitherto generally in use, more attention being paid to the average heights of the various types. There are, however, still distinct variations of cloud frequently seen, which are not represented in Dr. Singer's collection, and his system of classification, notwithstanding its merits, has defects which must, sooner or later, be dealt with.

THE *Times* of March 24 printed the following communication from a correspondent:—Under the direction of the Austrian Government an interesting series of deep-sea explorations has been conducted recently in the eastern parts of the Mediterranean, by a scientific party on board the *Pola*. At one point, about 50 nautical miles south-west from Cape Matapan, the *Pola* found a depth of 4400 metres (2406 fathoms), followed within a few miles further east by a depth of 4080 metres (2236 fathoms), which are the greatest depths recorded in the Mediterranean. They have received from the Austrian Hydrographical Board the name of *Pola Deep*. The great depression of the Mediterranean must thus be shifted considerably east from its former central position on the maps. Another deep area was



explored between Candia and Alexandria—the depths attaining from 3310 metres (1810 fathoms) some twenty miles south-east of Grandes Bay, and from 2392 metres (1208 fathoms) to 2120 metres (1322 fathoms) within a short distance from Alexandria; the maximum depth sounded being 3068 metres (1678 fathoms) in 28° 39' 30" north latitude, and 33° 19' 54" east longitude. The highest temperature was found during the first part of the voyage, at depths of 1 to 50 metres, the highest being 80°·8 Fahrenheit at 1 metre; the lowest temperature, 52½°, was observed at the issue from the Adriatic Sea, at a depth of 760 metres. In explorations conducted some two years ago in the Central Mediterranean, it was observed that the density of the water and its saturation with salt increased with depth, and the same was noticed in the western part of this year's cruise. But in the Eastern Mediterranean the density of water varies but very little in the different strata, and it is higher on the whole than in the west. The transparency of the water is very great in the Eastern Mediterranean. Altogether the *Pola* made no fewer than 50 deep-sea soundings, 27 of which touched depths of more than 1000 metres.

At a meeting of the Royal Geographical Society on Monday, a paper describing a recent journey to the head waters of the Ecayali, Central Peru, by Mr. Alexander Ross, was read by Sir Alfred Blunt. The journey was undertaken by desire of the Peruvian Corporation. Mr. Ross was accompanied by Mr. Arthur Sinclair, who, like himself, had spent many years planting in Ceylon; and, for research in economic botany, by Mr. P. D. G. Clark, assistant at the Royal Botanic Gardens, Peradeniya, near Kandy, Ceylon. Their travels lasted five months, and were confined to the central portions of the interior. Mr. Ross said that not much of the Sierra visited by them was suited to modern systems of tillage. But in the Montaña there were vast areas at suitable altitudes well adapted for settlement by European immigrants. In the lower parts of the Amazon basin, in a climate more or less unsuited to white labour, immense tracts awaited only the introduction of Chinese or the Indian coolie to turn what was now a magnificent forest wilderness into a rich and thriving province. The Central Railway would have been completed to Oroya in June next, and the Chanchamayo road would be opened soon thereafter. In continuation of these, and to connect them with the navigable waters of the Amazon, the survey of a railway line had already been ordered. The immense influence these would have upon the future of Peru and its progress would then become apparent. At present, to those who had not seen that country's varied and unlimited mineral resources, its grand forests, its rich soil and splendid rivers, a full realization of the future of Peru was impossible.

At a meeting of the Royal Botanic Society on Saturday last, the Secretary, in calling attention to the various examples of azleas in flower from the Society's Gardens shown at the meeting, remarked upon the many intermediate forms represented between the single and so-called double varieties. In some the stamens were only beginning to assume a flattened shape, the anthers still remaining at the top; in others, again, following the usual course of formation of double flowers—namely, by alteration of parts instead of adding to their number, the whole of the internal organs had become changed into petals, depriving the plant of all opportunity of reproducing itself by seed.

THERE is some difference of opinion in America on the question whether the method of execution by electricity ought to be maintained. The American journal *Electricity* maintains strongly that it should. The newspaper reports as to the electrical executions which have already taken place go to show, it contends, that death has been almost instantaneous in every case. While this has been disputed by a few witnesses, almost all have conceded that loss of consciousness has followed immediately on

the application of the current. "The muscular action which has been noticed cannot for a moment," says *Electricity*, "be attributed to any consciousness on the part of the criminal. It is purely a reflex nervous action which can be reproduced by applying a current to the nerves of an animal which has been dead for some time; in fact, a most vigorous muscular action can be set up in a dead body in this way. That the victim, however, is alive, or that he suffers pain in any degree, is not for a moment to be considered."

The new number of the *Economic Journal* contains, among other things, the Rev. Prof. W. Cunningham's inaugural lecture delivered at King's College, London. It is on the relativity of economic doctrine, and is conceived in a thoroughly scientific spirit. In the course of his argument, Prof. Cunningham urges that the results of economic investigation are relative in a way in which the results of physical investigation are not. The physicist announces principles which hold good, without substantial modification, for the whole period of human existence on the globe; whereas there are areas, and probably periods of human existence, to which the very simplest economic principles are hardly applicable, since there are tribes which seem to be destitute of ideas of exchange. The movement of the earth, the principle of gravitation, are entirely independent of human existence and unmodified by its changes. Economic principles, on the other hand, are statements about human nature in some of its aspects; and the alterations in the human race, their habits and practices, cannot be left out of account, more especially as the economic side of life occupies a very different importance at different stages of human progress. In consequence of this distinction between economical and physical investigation, results that may be used as the bases of practical applications cannot be as readily obtained in economics as in physics. The art of navigation follows very closely on the observations and principles expounded by the astronomer, but there is need of much correction and allowance before the principles of the economist can be applied by the statesman to steer his course in regard to the details of any great social measure.

PROF. G. H. WILLIAMS, in an interesting paper printed in the latest of the "Johns Hopkins University Circulars," speaks of the important part played in the growth of geological opinion by those regions which happen to be near great Universities. Such districts, as he says, were naturally earliest and most thoroughly studied, and have therefore become classical for all subsequent comparison. He especially mentions the mining districts of Freiburg and Clausthal, the volcanic regions of Edinburgh and Bonn, and the Tertiary basins of Paris and Vienna. These have become, once for all, the type-localities for the geological formations which surround them. Such masters as Werner, Hutton, von Dechen, Cuvier, and Suess, have worked there, erecting monuments to themselves in the regions which they have interpreted. Prof. Williams's practical conclusion is that Maryland, which, from a geological point of view, is full of interest, ought to be thoroughly investigated by geologists connected with the Johns Hopkins University.

THE Council of the Mason Science College, Birmingham, append to their report for the year ended February 23, 1892, some interesting extracts from a report by the Principal on the educational work of the College. From these we are glad to learn that the year, although marked by no new and striking developments of the College work, was throughout a year of continued prosperity, both in regard to the number of systematic students attending the College classes and the excellence of the work done, as testified by the honours won at various University examinations. There was a decrease in the number of students attending the departments of zoology, botany,

metallurgy, and engineering, but a large increase in connection with the departments of modern languages, geology, chemistry, physics, and physiology.

THE Rugby School Natural History Society has now been at work for twenty-five years, and its report for the year 1891 shows that it is still full of vigorous life. The geological section, which lapsed ten years ago, has made a fresh start, and the meteorological, the architectural, and the photographic sections are stated to be "in a flourishing condition." The editors have added to the report an index of all the papers and records which have been published by the Society from the beginning.

WITH regard to the influence of electricity on the growth of plants, a series of experiments made by Prof. Aloï on *Lactuca Scariola*, maize, wheat, tobacco, and beans, indicate that atmospheric electricity exercises a beneficial influence on vegetation; that the electricity of the soil has a similar influence on the germination of seeds; and that the less luxuriant vegetation of plants which grow in the neighbourhood of trees is in great part due to the diminution of temperature.

THE effects of earthquakes on vegetation have been investigated by Signor A. Goiran, in the case of the seismic disturbances which occurred last June throughout Northern Italy. He found in this instance the uniform result to be to induce a more rapid germination of seeds, and a more rapid growth of the young plants, giving rise to a more luxuriant vegetation in the pastures, arable lands, vineyards, and shrubberies, accompanied by an unusually deep green colour of the leaves. These results he believes to be due, not to the direct influence of the tremor, but to three secondary causes, viz. (1) an increased production of carbon dioxide; (2) a diffusion of nutrient fluids through the soil, acting as a kind of natural manuring; (3) an increased production of electricity. In other instances earthquakes have apparently had an unfavourable influence on vegetation; but this Signor Goiran believes to be due to their having been associated with a long period of drought.

OF the recently published *Indian Museum Notes* one of the most interesting papers is on the wild silk insects of India. It is by Mr. E. C. Cotes, and is intended to serve as a supplement to a previous paper on cultivated silk-producing insects. A small amount of silk is spun by the caterpillars of most moths. The only groups, however, which contain species whose silk is at all suited for utilization are the Saturniidae and the Bombycidae, and the whole of the Indian species belonging to these groups, therefore, have been included in the present report, though many of them do not produce sufficient silk to be of any use. So much, however, has of late years been said about the wild silk insects of India, and such exaggerated opinions have been expressed as to their value, that it has been thought best to deal exhaustively with the matter, so as to clear the ground and show precisely how the question really stands.

THE Royal Agricultural and Commercial Society of British Guiana has been discussing the question whether an Agricultural College should not be established in the colony. At a recent meeting Mr. Jacob Conrad brought forward a motion to the effect that a Committee should be appointed to petition the Government on the subject. He failed, however, to obtain the support of a majority. Mr. Darnell Davis thought it desirable that the question should be discussed, but could not see how anything practical would come out of it unless some kind philanthropist found the money. Agricultural Colleges were very expensive, and he did not think the Government could be asked to do anything, as it would mean the imposition of additional taxes. He thought that every sugar plantation in the colony was really an agricultural school.

MRS. ZELIA NUTTALL contributes to the new number of the *Internationales Archiv für Ethnographie* a learned and interesting paper on ancient Mexican shields. She divides them into the following groups:—(1) Plain, unadorned war-shields of several kinds, used by the common soldiery. (2) Gala-shields, indicating the military rank and achievements of chiefs. These seem to have been indiscriminately used in warfare or feasts and dances. Their general structure seems to have been alike in either case, though they may have been more or less light and strong. Shields of this category sometimes reproduced one or more features of the military costume, body-painting, and adornments pertaining to each grade. (3) Shields, presumably of the supreme war-chief, exhibiting in picture-writing the name of his people or his personal appellation. Nothing certain is known about this group, but its existence seems vouched for by a series of indications. (4) Shields pictured in the codices with deities only, exhibiting their emblematic devices or reproducing features of their symbolic attire. Such shields seem to have been carried, in religious dances and festivals, by the living images of the deities in whose honour they were celebrated. (5) Shields of most precious materials, with strange and elaborate designs, described in the inventories. As they are not mentioned elsewhere, it is not possible to state anything definite about them, but it is obvious that they were intended for the use of individuals of supreme rank. The beautiful shield preserved at Castle Ambras, near Innsbruck, belongs to this group. It is the only known specimen with a valid, though shadowy, right to the title of "Montezuma's shield."

ACCORDING to Mr. A. Sidney Olliff, who writes on the subject in the *Agricultural Gazette of New South Wales*, the "metropolis" of the plague locust of New South Wales is in the western district, especially in the great plains between the Lachlan and the Darling Rivers. The breeding-grounds of locusts in Australia are as extensive as those of the Rocky Mountain locust, and are found in similar situations. The eggs are deposited in vast quantities in the earth, close beside one another, frequently over a large tract of country. Usually these breeding-grounds occur in sandy soils or in high dry places, but occasionally they may be found on the banks of a creek. At the end of September last, during a hurried visit to Renmark, in South Australia, Mr. Olliff found the bare sandy banks of a small creek riddled with small holes from which the newly-hatched locusts had but just escaped. Swarms of young locusts had previously been observed by him near Wentworth, making their way from the bare places in which they were hatched to the richer pasturage. The U.S. Entomological Commission has carefully investigated the various ways in which these pests can be most effectually dealt with; and a condensed account of the results is presented by Mr. Olliff for the benefit of Australian farmers.

THE Marine Biological Association, Plymouth, has issued a new price-list of zoological specimens. This cancels the previous list. The specimens are suitable for class or laboratory examination, and for museum purposes. They are kept in stock at the Plymouth Laboratory, and are to be obtained on application to the director.

THE following arrangements have been made for science lectures at the Royal Victoria Hall during April:—April 5, Henry M. Bernard, on "Life in Russia"; April 12, A. H. Fison, on "The Compass Needle"; April 26, Captain Charles Reade, on "The British Navy."

MESSRS. MACMILLAN and CO. have issued the sixth edition of Sir Henry E. Roscoe's well-known "Lessons in Elementary Chemistry." The fifth edition, which has been repeatedly reprinted with slight corrections, was published in 1886. The author has tried to introduce into the present edition all the

more important discoveries of the last six years, and to make such general improvements as he has thought likely to be of benefit to his readers.

THE April number of *Natural Science*, the new monthly review of scientific progress, has articles on factors in the evolution of the Mammalia, by Prof. C. Lloyd Morgan; some salient points in the study of mammals during 1891, by R. Lydekker; the physical features and geology of Borneo, by F. H. Hatch; great lakes, by Clement Reid; life-zones in Lower Palæozoic rocks, by J. E. Marr, F.R.S.; and a new group of flowering plants, by A. B. Rendle.

MESSRS. KEGAN PAUL, TRENCH, TRÜBNER, AND CO. have issued a second edition of Mr. B. H. Chamberlain's "Things Japanese." The work consists of a number of independent articles, arranged alphabetically, and giving an account of the Japanese people, their country, their ideas, and their industries. It has been enlarged by the insertion of over twenty new articles, while the old have been corrected up to date, and re-written in many parts. The style is compact, fresh, and lucid, and at the end of the more important articles the author gives a list of books in which further information may be obtained. Several subjects have been intrusted to specialists. Prof. Milne contributes the article on "Geology," and Mr. Mason those on "Telegraphs," "Chess," and the game of "Go."

THE "School Calendar" for 1892 has been published, this being the fifth year of issue. Mr. F. Storr, referring in the preface to the movement for the registration of teachers, notes that head masters who have hitherto ignored or sneered at the teaching diplomas of the University of Cambridge are beginning to send up their assistants for the examinations of the Syndicate, or even to enter themselves.

THE new number of *L'Anthropologie* (tome iii., No. 1) opens with an interesting paper on A. de Quatrefages, by Émile Cartailhac. The paper is followed by a useful list of the principal publications by M. de Quatrefages. M. Marcellin Boule contributes some excellent notes on the formation of fossiliferous deposits in caves. There are also papers on the tumulus-dolmen of Marque-Dessus (commune d'Azereix, Hautes-Pyrénées), by General Pothier; on the respective association of anthropological characters, by Dr. R. Collignon; and on the ethnological position of the peoples of Ferghanah, by Paul Gault.

THE U.S. Geological Survey has lately issued a number of important papers in its series of *Bulletins*. One of them (No. 69) contains a classed and annotated bibliography of fossil insects; another (No. 71), an index to the known fossil insects of the world, including Myriapods and Arachnids. No. 72 gives the altitudes between Lake Superior and the Rocky Mountains; No. 74, the minerals of North Carolina; No. 75, a record of North American geology for 1887 to 1889 inclusive; No. 79, an account of a late volcanic eruption in Northern Carolina, and its peculiar lava. No. 76 is the second edition of a dictionary of altitudes in the United States.

WE have received Parts 41 and 42 of Cassell's "New Popular Educator." Both, like the previous parts, are carefully illustrated. In addition to the cuts introduced into the text, Part 41 has a coloured picture of "the Spectre of the Brocken," and Part 42 a coloured map of the Balkan Peninsula.

THE Hunterian Oration, delivered by Dr. J. Hutchinson, F.R.S., in the theatre of the Royal College of Surgeons on February 14 last, has now been published by Messrs. J. and A. Churchill.

THE additions to the Zoological Society's Gardens during the past week include a Macaque Monkey (*Macacus cynomolgus* ♂) from India, presented by Mr. F. D. Lyon; a Rhesus Monkey

(*Macacus rhesus* ♀) from India, presented by Mr. J. G. Wythe; a Brush Bronze-winged Pigeon (*Phaps elegans* ♀) from Australia, presented by Mr. H. H. Sharland, F.Z.S.; two Red Kangaroos (*Macropus rufus* ♀ ♀) from Australia, deposited; two Great American Egrets (*Ardea egretta*), two Snowy Egrets (*Ardea candidissima*) from America, two Buff-backed Egrets (*Ardea russata*), European, purchased; an Eland (*Oreas canna* ♂), born in the Gardens.

#### OUR ASTRONOMICAL COLUMN.

THE PLANET JUPITER.—During the last year or so the planet Jupiter has been the subject of many observations both at home and abroad. The curious markings that become visible from time to time have been very carefully watched, and the changes which they have been seen to undergo likewise recorded. Those who take a special interest in these observations will find in *L'Astronomie*, under the title of "Recent Discoveries on Jupiter," a most excellent article written by M. Camille Flammarion. The author, after giving a description of the general state of the planet that can be gathered from a telescopic and spectroscopic survey of his surface, adds a *résumé* of the important observations made by M. Terby, at Louvain, which were originally addressed to the Belgian Academy. Many very important facts relating to the positions which the dark and light spots take up are here collated, and the numerous illustrations impress one strongly with the vastness and rapidity of the changes that are continually in progress.

*Astronomy and Astro-Physics* for March contains also some notes on this planet, communicated by Mr. H. C. Wilson, of the Goodsell Observatory, who, armed with a 16-inch equatorial during the winter of 1891, completed many sketches, some of which are here exhibited. These observations seem to indicate that as the dark belt approached the great red spot which is situated just north of it, the latter appeared to force it to one side, "there being always a very narrow line of white between the belt and spot." This fact seems to show that, whatever the spot may be composed of, it has the power of dissipating the clouds in close proximity to it.

THE OBJECTIVE PRISM.—Prof. Pickering, in the March number of *Astronomy and Astro-Physics*, communicates a very interesting article relative to the method of photographing the spectra of the stars with an objective prism. As an account of this method has already been described in these columns in the review of the catalogue published under the name of "The Draper Catalogue," it is unnecessary for us to enter into the details again. At the latter end of the article he mentions also that "a still further advance will be made with the great photographic telescope, the gift of Miss C. W. Bruce." This instrument is stated to be similar to the "Bache telescope," but three times as large, having an aperture of 24 inches. The spectra of stars down to the 10th and 11th magnitude are expected to be obtained with it. The engraving which accompanies the text illustrates the method of attaching the large prism to the object-glass end of the telescope.

VARIATION OF LATITUDE.—Dr. B. A. Gould, in the *Astronomical Journal*, No. 257, presents us with some of the work which he has been undertaking with regard to the periodic variation of the latitude at Cordoba, from observations made with the meridian circle. The results obtained by Dr. Chandler showed that by assuming a period of fourteen months, the variations in the latitude, determined between the years 1860 and 1875, could be accounted for. Dr. Gould thought that the same period might be found to satisfy the Cordoba observations, and the computations that he has made form the subject of the present inquiry. Owing to the fact that this number of the *Journal* does not contain the whole of the work (the latter part of which will be concluded in the next one), we are not able to give the results which he has obtained, but we can mention a point that seems of importance, and which tends to corroborate Dr. Chandler's results.

In a table showing the mean excess of the calculated, above the observed, declinations, the author remarks that "there are two facts which attract attention: first that the times of maxima and minima of the curve are approximately coincident with those deduced by Dr. Chandler from contemporaneous observations in other places; and, secondly, that the corresponding

periodical fluctuations of the curve are markedly inferior to other and larger variations upon which they appear superposed. . . The range included between these extremes amounts to two seconds, and is altogether too large to be attributed either to personal equation or to any instrumental origin."

**THE DISCOVERY OF NEPTUNE.**—During a visit to England, in 1876, Prof. Holden was frequently with Mr. Lassell, and he then learned a circumstance connected with the discovery of Neptune which is not without interest. Now that Adams and Lassell are both gone, Prof. Holden has published the brief notes he made at the time, as a contribution to the history of the great discovery. It is well known that, in October 1845, Adams submitted to the Astronomer-Royal his computations indicating the existence of an unknown world beyond Uranus. The work was shown to Dawes, and he was so much impressed by it that he wrote to Lassell, asking him to search for Neptune in the region designated by Adams. Had the discoverer of the two inner and faint satellites of Uranus, and the satellite of Neptune, directed his 2-foot reflector to this region, there is little doubt but that the planet would have been picked up. However, the Fates ordained otherwise: Lassell was confined to his sofa by a sprained ankle, and, when he recovered, the letter of Dawes, giving the predicted place of Neptune, could not be found. It turned out to have been destroyed by a too-zealous maid-servant. Thus, "by a set of curious chances," the new planet was never looked for by the then most powerful telescope and most skilful observer in England. It was not until many months after the letter of Dawes to Lassell that the planet was found by Galle and D'Arrest, near the position given by Leverrier.

**ASTRONOMY AT THE PARIS ACADEMY, MARCH 21.**—At the meeting of the Paris Academy of Sciences, on March 21, M. Lewy presented a picture of the Orion Nebula obtained at Toulouse Observatory, with an exposure of five hours, on February 24, 25, and 26.

M. Bigourdan observed Swift's comet on March 17, 18, 19, and 20, and determined its position. He describes it as "a bright nebulosity, 2' in diameter, without a tail, and with a well-defined stellar nucleus, the light of which is comparable with that of a star of the eighth or ninth magnitude." Denning's comet was seen on March 19 and 20, and five observations of position were made. It is described as "a feeble nebulosity without a tail, 25' to 30' in diameter, brighter towards the centre, but without any apparent nucleus. Its light was at the most equal to that of stars of magnitude 13." M. Rayet observed Swift's comet on March 17 and 19, and estimated that its nucleus was of the sixth or seventh magnitude.

M. Terby, in a letter to M. Faye, claims priority for the idea that solar spots and other disturbances on the sun exert an influence on terrestrial magnetism and electricity which varies according to the position of the phenomena with reference to the sun's visible disk. In a paper presented to the Brussels Academy in 1883, "On the Existence and Cause of a Monthly Periodicity of Auroræ," he showed that the fluctuations in frequency of auroræ were connected with the period of the sun's synodic rotation. Hence, some portions of the solar surface seem more capable of exerting terrestrial influence than others.

**VARIABILITY OF NEBULÆ.**—In NATURE of January 14 (p. 261) some observations were described which seemed to indicate that a nebula in R.A. 3h. 36m., Decl. 95° 2' 1", was variable. Dr. Lewis Swift notes, in *Astronomy and Astro-Physics*, that he has again looked for the nebula, and on January 31 succeeded in getting two glimpses of it, using a power of 195. Although Dr. Swift is not inclined to believe that the nebula is variable, it is strange that he should at one time have picked up the object whilst sweeping, and yet not be able to find it afterwards, even with the most persistent searching. That Dr. Dreyer, also, should have failed to see the nebula on several occasions, although he knew where and what to look for, is almost unaccountable, if the brightness is uniform. It is to be regretted that the illumination of the sky at Rochester, from the electric lights, seems likely to prevent Dr. Swift from continuing his search for nebulae.

**SOLAR PROMINENCE PHOTOGRAPHY.**—As the great spot-group of February was again coming round the sun's east limb on March 3, M. Deslandres observed over it a prominence. He also photographed it, and, at the meeting of the Paris

Academy of March 14, communicated the results obtained. The Fraunhofer lines H and K are very bright on the photographs, and the entire series of ultra-violet hydrogen lines are plainly visible. Other lines are seen which have not previously been recognized as chromosphere lines, viz. the magnesium triplet about  $\lambda$  383, and lines at  $\lambda$  375.93, 376.14, and 368.53, the origins of which are unknown.

**THE AURORA SPECTRUM.**—The aurora of February 13 was seen at Chicago, and Prof. Hale made some observations of its spectrum, using a small direct-vision spectroscope. A bright band was made out in the red, near C, and another was identified as the characteristic aurora-line. A very faint line, broad and hazy, appeared in the green, near the position of  $\delta$ , and a faint one near F.

### THE PROPERTIES OF AMORPHOUS BORON.

THE properties of pure amorphous boron form the subject of a contribution to the current number of the *Comptes rendus* by M. Moissan. In our chemical note of March 3 (p. 421), the method was described by which M. Moissan has recently succeeded in preparing the amorphous form of boron in a state of almost perfect purity. The method consisted in reducing an excess of boric anhydride with powdered metallic magnesium, and subsequently repeatedly extracting the soluble products by acids. He now proceeds to describe the physical and chemical properties of the element as thus obtained. Pure amorphous boron is a fine chestnut-coloured powder, which may be readily moulded into adhesive masses by pressure. Its density is 2.45. It is infusible, even at the temperature of the electric arc. When heated in the air to a temperature in the neighbourhood of 700°, it inflames, and burns with formation of boric anhydride. If a small quantity is heated strongly in a test-tube, and, while hot, thrown into the air, a host of brilliant sparks are produced. When the powder is heated in a current of oxygen it burns with an intensely luminous flame, which, when the experiment is performed in a dark room, is observed to possess a green tint. The rays emitted are almost devoid of actinic power, the greater portion of the chemically active end of the spectrum being wanting. Pure amorphous boron reacts in a beautiful manner with sulphur at a temperature of about 610°, brilliant incandescence occurring with production of sulphide of boron. This latter substance is decomposed by water with liberation of sulphuretted hydrogen. Selenium reacts with amorphous boron in an analogous manner at a higher temperature, but without incandescence, the selenide of boron produced evolving hydrogen selenide when brought in contact with water. Tellurium, however, may be fused in presence of boron without any reaction occurring.

When amorphous boron is heated in an atmosphere of chlorine at 410°, combination accompanied by bright incandescence occurs with formation of chloride of boron, which, if the experiment is performed in a suitable apparatus, distils over into a receiver placed to intercept it. Bromine combines with boron to form the liquid bromide of boron at a temperature approaching 700°, the reaction likewise being accompanied by incandescence. Even bromine water attacks boron, although slowly, at the ordinary temperature, and an aqueous solution of bromine in potassium bromide attacks it rapidly. Iodine appears to be without action even at a red heat. Amorphous boron only combines directly with nitrogen at a high temperature, mere traces of the nitride being produced at temperatures below 900° when the powder is heated in a current of nitrogen; but at about 1200° combination rapidly occurs. The vapours of phosphorus, arsenic, and antimony do not react at available temperatures. When amorphous boron is heated in the electric arc in an atmosphere of hydrogen, boride of carbon is formed with a portion of the carbon of the poles.

The behaviour of metals towards amorphous boron is somewhat singular. The alkali metals may actually be distilled over the powder without any apparent trace of combination. Magnesium, on the contrary, combines with boron to form a boride at a low red heat. Iron and aluminium also form borides at a red heat, and silver and platinum react with even greater facility.

Acids react with amorphous boron with considerable energy. At 250° sulphuric acid is reduced to sulphur dioxide. Nitric acid in small quantities produces incandescence. Phosphoric anhydride is reduced at 800° to phosphorus. Arsenious and

arsenic acids are reduced at low redness with sublimation of anuli of arsenic. When the powder is dropped into a warm solution of iodic acid, iodine is liberated, and if a mixture of amorphous boron and crystallized iodic acid is slightly warmed, it takes fire, and a cloud of iodine vapour is produced. Gaseous hydrofluoric acid attacks amorphous boron at low redness, hydrogen being liberated, and fluoride of boron produced. Hydrochloric acid only reacts at bright redness.

Steam does not react with boron below a red heat, but the moment incandescence commences at any point the decomposition proceeds with explosive violence, hydrogen being liberated and boric anhydride produced. Carbon monoxide is reduced by boron at 1200°, with formation of boric anhydride and deposition of carbon. When amorphous boron is heated to low redness in a current of nitrous oxide, incandescence is produced, and boron nitride and boric anhydride are formed. Nitric oxide, however, does not react with boron under these circumstances.

Metallic oxides are much more readily reduced by boron than by carbon. For instance, when a mixture of copper oxide and amorphous boron is heated in a glass test-tube, the heat produced in the act of reduction is so great that the glass immediately fuses. Oxides of tin, lead, antimony, and bismuth are immediately reduced upon slightly warming, and the mass becomes white hot. When peroxide of lead is rubbed in a mortar with amorphous boron, a violent detonation occurs. Oxides of iron and cobalt are reduced at a red heat, but the alkaline earths are not attacked by boron. When caustic potash is fused in contact with amorphous boron, a vigorous reaction occurs, with rapid evolution of hydrogen.

The great affinity of boron for oxygen may be readily shown by making a gunpowder in which carbon is replaced by boron; if such a mixture of amorphous boron, sulphur, and nitre is made, it will be found to explode considerably below the lowest red heat. If a few particles of amorphous boron are allowed to fall into fused potassium chlorate, quite a pyrotechnic display is produced. The behaviour of certain fluorides towards amorphous boron is interesting. Silver fluoride, for instance, reacts in the cold upon simple contact in a mortar, with incandescence and detonation. Many other fluorides are similarly decomposed on warming.

Sulphates of potassium and sodium are reduced to sulphides at a low red heat by amorphous boron with great energy, the mass becoming white hot. Fused nitre, however, only reacts at the temperature at which oxygen commences to be evolved, but fused nitrides of the alkali metals react with violence, and production of light and heat. Sodium carbonate, moreover, is reduced at the temperature of low redness with vivid incandescence. The reducing capabilities of boron appear to be even manifested in presence of water, for the powder rapidly decolorizes a solution of permanganate, and reduces solutions of ferric salts to ferrous. Silver nitrate in solution is reduced with deposition of crystals of metallic silver; gold chloride also yields an immediate precipitate of finely divided gold, and platinum chloride is likewise reduced with precipitation of platinum upon warming.

A. E. TUTTON.

### THE MANCHU RACE.

THE origin of the Manchus—the race to which the reigning dynasty in China belongs—is discussed by a writer in the *North China Herald*, of Shanghai. He says that the Tungus people are scattered about in Siberia and Manchuria in rather small communities of several hundreds or thousands each. In 1854 there were about thirty-five or forty thousand persons altogether in Siberia belonging to this race. Being hunters and fishers they find it best to live on the banks of rivers and on the seaside for fishing, and in wooded hill countries for hunting. They are met with, consequently, on the shores of the Baikal, and on the upper waters of the Lena, which rises among the mountains west of that inland sea. These few colonies of this race are under the jurisdiction of Irkutsk. Still farther west there are a tribe or two on the Yenisei. Those on the Lena are near the part where the mammoth and other wild animals formerly had their haunts. The frozen remains of these ancient creatures are found chiefly at the mouth of the Lena, which flows north to the Arctic Sea through about twenty degrees of latitude from the neighbourhood of Baikal. On the east of the Baikal, Nerchinsk and the banks of the Orchon and Onon Rivers are preferred by this people, who are irregularly scattered

among the Buriat tribes in this part of Siberia. In the Amur territory of Russia they occupy parts of the sea coast, and are known as the Orochtes and Goldi. It is because the salmon and other fish that they live on are found in abundance that they here build their movable huts. In the Russian Amur province there are about forty thousand of them, representing an ancient race which, as their language, joined with the facts of Chinese history, shows, must have occupied these same territories and prosecuted these occupations for thousands of years. In Kirin province there are, it is likely, a corresponding number, for the trade with China always demands sable skins, otter skins, squirrel skins, beavers, ermines, and fox skins in an ever-increasing quantity. It is this demand for skins that maintains the tribes in the north part of Kirin province residing on the banks of the Usuri and other streams which flow north into the Amur.

The Tungus tribes to which the Manchus belong first appear in history in the Chow dynasty. They are the Sokdin or Sushen of that age, and they were powerful in the eleventh century before our era. They are mentioned in the preface of the Book of History, so that we have next to classical authority for their existence at that distant period as a powerful state. The historian Tso mentions them in the sixth century, and from the way in which he speaks they were the strongest race in Tartary at the time. But in the third century, after nine hundred years of honour, their star went down, and the age of Turkish ascendancy arrived. The Hiung-nu Turks of the Han dynasty had emperors of their own, who at least on one occasion were received in China on terms of equality with the haughty sovereigns of their southern neighbours. They could call themselves eldest sons of heaven and brothers of the sun and moon, just as the Chinese could, and therefore they did so. But their star also went down. The Turkish race has been used to rule wild tribes for 2000 years. We know that the Hiung-nu were Turks by the words left of their vocabulary which are found recorded in Chinese history. But their power declined, and then the Sushen, or Tungus, rose again to influence, and it was because they lived in the eastern provinces, where the valleys are rich in productive power, and because they had the good sense to profit by Chinese teaching. When China conquered the Moukden province and Corea, a century before the Christian era, the result was that the habits of life of the Chinese and their moral and intellectual activity spread to the east and north-east. Tungus and Corean tribes came under this new influence, and grew more powerful in proportion to the progress they made in the adoption of a civilized life. The Tungus Ambassadors arrived at Loyang in A.D. 263 and 291; and a few years later, when the Tsin Emperor had removed his Court to Nanking, they appeared there. Probably they came from the mouth of the Newchwang River by sea, for we know that the Chinese junk-masters navigated the Gulf of Pechili fully 2000 years ago. The troops which subjugated Corea at that time were there in large junks. Meanwhile other branches of the Tungus race had become sufficiently powerful to disturb the quiet of North China. Among them were the Owan and Sien Pi. The Sien Pi and the Hiung-nu conquered large portions of Chinese territory. The Tungus people ruled in the province of Peking. The Turks occupied Shensi, and Tibetan tribes took possession of Shensi. Each of these races seized on that part of North China which lay contiguous to their homes in Tartary. This state of things lasted till the latter part of the fifth century, when the Chinese drove the Tartars out. Again, however, at the beginning of the twelfth century a Tungus race conquered North China, and was followed later by a Mongolian dynasty, to which the Chinese of north and south all submitted for a hundred years.

The Mongols as a race are probably an offshoot from Tungus stock. There are differences, but there is on the whole a great resemblance. The consanguinity that exists between Manchu and Mongol is greater than that which is found to prevail between Mongol and Turk; and therefore it may be concluded that the Tungus, either in Siberia or in Manchuria or on the Amur, threw off a branch which became Mongol. This would be of a very ancient date; for otherwise the grammars of the Mongol and Manchu would be more alike than they are. Genghis Khan and his tribe started on the conquest of the Asiatic continent from the neighbourhood of the gold mines in Nerchinsk, and the Mongols are not fishermen by preference nor hunters of the sable martin and the beaver. They are rather keepers of sheep and riders of horses and camels. They

might easily develop their language in the vicinity of the Altai Mountains and the Baikal.

As to the Manchus, they have forgotten their early occupations since coming to China, and they attend now only to the duties of the public service or to military training. The language, like the Mongol, is rich with the spoils of antiquity. All the various forms of culture, whether belonging to Shamanism, Confucianism, or Buddhism, with which they have become successively familiar, have contributed a share. To these must be added the vocabulary of the huntsman, the fisherman, and the shepherd, and all the terms necessary for the feudal relationship as well as those of the trades and occupations of the old civilization.

### SOCIETIES AND ACADEMIES.

#### LONDON.

**Physical Society, March 11.**—Prof. A. W. Rücker, F.R.S., Vice-President, in the chair.—Mr. H. M. Elder read a paper on a thermodynamical view of the action of light on silver chloride. In the decomposition of silver chloride by light, chlorine is given off, and a coloured solid body of unknown composition (sometimes called "photochloride") formed, the reaction being indicated by the formula  $n\text{AgCl} = \text{Ag}_n\text{Cl}_{n-1} + \frac{1}{2}\text{Cl}_2$ . If the experiment be carried out in a sealed vacuum, the chloride is darkened up to a certain point, but regains whiteness when left in the dark. These facts have led the author to believe that the pressure of the liberated chlorine is a function of the illumination or intensity of light falling upon the chloride, in the same way as the pressure of a saturated vapour is a function of the temperature. Since illumination is a quantity in many respects analogous to temperature, he considers it not unreasonable to apply thermodynamic arguments, and regard chlorine in presence of silver chloride and "photochloride" as the working substance in a "light engine." He therefore supposes a Carnot's cycle to be performed on the substances at constant temperature, the variables being pressure, volume, and illumination. Since the cycle is strictly analogous to Carnot's, except that illumination is written for temperature, he infers that the efficiency is a function of the two illuminations. It also follows that just as Carnot's cycle is used to determine an absolute scale of temperature, so this cycle may be applied to determine an absolute scale of illumination. It only remains to determine an empiric scale analogous to the air thermometer, and to compare it with the photodynamic scale, provided a method of making the comparison can be devised. Assuming the axioms applied to Carnot's cycle are true when illumination is written for temperature, the author shows mathematically that  $\beta \propto I^{\rho/T}$ , where  $\beta$  is the pressure,  $I$  the illumination,  $T$  the absolute temperature, and  $\rho$  the heat of combination per gramme-molecule of chlorine evolved. If  $P$  be the heat of formation of silver chloride, the fraction  $\rho/P$  may be considered as expressing the fraction of the total chlorine that can be removed by the action of light upon it, supposing the gas removed so as to keep the pressure below that corresponding to the illumination. The chemical equation might then be written—

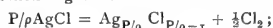

thus the formula for "photochloride" would be  $\text{Ag}_{P/\rho} \text{Cl}_{P/\rho-x}$ . Prof. Rücker read a letter from the President (Prof. Fitzgerald) on the subject of the paper. He inquired what axiom corresponding with the second law of thermodynamics was employed. He was not sure that the engine was perfectly reversible, and felt doubt on the subject of phosphorescence mentioned in the last operation of the cycle. Nevertheless, the paper was a most interesting one, and very suggestive. Prof. Herschel pointed out that Becquerel's phosphoscope showed that all kinds of light produced phosphorescence, and thought that, in considering the subject, the non-thermal character of photographic light should be kept in view. Mr. Baker said he had been working on silver chloride for several years, and found that no darkening whatever took place if kept dry and *in vacuo*. He considered oxygen necessary to the action. Dr. C. V. Burton, referring to the motivity of the system, said that only a small fraction of the energy of the illumination was actually made use of. He also thought it necessary to consider how far the second law of thermodynamics could be treated as an axiom. He himself had been led to be-

lieve the law did not hold for mixtures of substances differing in a finite degree from one another. Some time ago he experimented on a solution of sodium sulphate placed in a dialyzer kept at constant temperature. The more acid portion passed through the membrane, and on mixing a rise of temperature was observed; the dialyzer thus acted like Maxwell's demons, and the mixing increased the motivity of the system. Prof. Rücker expressed his doubts as to whether the cycle described in the paper was strictly analogous to that in Carnot's problem. In the latter case the parts of the working substance only differed infinitesimally from one another, whilst in the former the working body was a mixture of two solids and a gas. In order that the increased illumination should not alter the temperature, heat must be carried away. According to the paper, the first part of the cycle must be both adiabatic and isothermal. This seemed hardly possible. If the chlorine alone be considered, it could not be true, and it could only hold if the chloride absorbed all the heat given out by the compression of the chlorine. This seemed improbable, but, if true, it would be very important. Captain Abney saw another difficulty in the fact that at low temperatures silver chloride is not acted on even by violet light, whereas heating greatly increases the action. In his opinion the conclusions arrived at required confirmation, but the paper would form a starting-point for many new experiments. Mr. Elder, in reply to Prof. Fitzgerald, said the axiom corresponding to the second law as stated by Clausius might be formulated thus: Energy cannot of itself pass from a less bright to a brighter body. In the paper he had assumed that the energy given out during compression at the lower illumination was of the same quality as that absorbed at the higher. The whole question depended on comparisons of intensities of illuminations of different wave-lengths. In the expression  $\beta \propto I^{\rho/T}$ ,  $\rho$  was probably a function of  $T$ , and Captain Abney's objection was not necessarily fatal. Speaking of the presence of oxygen being essential to decomposition, he believed some sensitizing body was necessary, but judging from experiments he had seen, an infinitesimal quantity would probably be sufficient, for the action seemed to be of a catalytic nature. He felt the weight of Prof. Rücker's objections, but thought they might possibly be met.—A paper on choking coils was read by Prof. Perry, F.R.S. Regarding a choking coil as a transformer with one primary and many secondaries represented by the conducting masses, he pointed out that all the secondaries might be replaced by a single coil of  $n$  turns, and resistance  $r$  ohms, short-circuited on itself. Assuming no magnetic leakage, the equations for the two circuits at any instant are  $V = RC + N\theta I$ , and  $O = rc + n\theta I$ , where  $N$  and  $n$  are the turns,  $R$  and  $r$  the resistances,  $I$  the total induction (in  $10^8$  C.G.S. lines), and  $C$  and  $c$  the primary and secondary currents respectively. Since the exciting current,  $C$ , is all-important in choking coils, and its value depending on the law of magnetization, the equations are treated in a different manner from that adopted in ordinary transformer calculations. Expressing the magnetic law as a Fourier series,  $I = \sum A_n \sin nx$ , the value of  $A$  (viz.  $NC + nc$ ) is deduced, and when  $V$  or  $I$  is given as a periodic function of the time,  $C$  may be calculated. Assuming  $V = V_0 \sin kt$ , the author finds

$$C = \frac{V_0}{N^2 r^2 \alpha k} \left\{ \sqrt{1 + 2\epsilon \sin f + \epsilon^2} \cdot \sin \left\{ kt - 90 + \tan^{-1} \left( \frac{\epsilon}{\cos f} \right) \right\} - b \cos 3kt - m \cos 5kt \right\},$$

where  $\epsilon = n^2 \alpha k / r$ ,  $f$  is the hysteresis term, and  $b$  and  $m$  constants depending on the law of magnetization. For ordinary transformer magnetizations,  $b = 0.2$ , and  $m = 0.05$ . From the above expression it will be seen that if there is no hysteresis (i.e.  $f = 0$ ), the effect of the eddy currents,  $\epsilon$ , is to increase the amplitude of the important term, and to produce a lead of  $90^\circ - \cot^{-1} \epsilon$ , whereas the effect of hysteresis without eddy currents is to leave the amplitude unaltered, and produce a lead  $f$ . Putting  $f = 0$  gives results in accordance with experimental observation, hence the author is inclined to believe that there is no hysteresis in transformers. He also points out that the higher harmonics must exist, and thinks it probably that a choking coil with finely divided iron may prove a method of increasing frequency by mere magnetic means. Taking the case of a 1500-watt transformer (2000 volts) unloaded, in which the loss in eddies was 40 watts, it is shown that a secondary of 2 turns, and resistance 1.9 ohms, would replace the eddy

current circuits. Assuming constant permeability and no eddy currents, the value of  $C$  comes out  $0.07398 \sin (kt - 90^\circ)$ , whilst with eddy currents and some saturation

$$C = 0.07911 \sin (kt - 69^\circ 2') - 0.014796 \cos 3kt - 0.003695 \cos 5kt.$$

Dr. Fleming said he was working on the subject of choking coils, and had found that, in closed-circuit transformers unloaded, the real watts were about 0.7 times the apparent watts. This, on the assumption of sine functions, would indicate a lag of about  $45^\circ$ . A similar rule for open-circuit transformers was much needed. It was important to know what size of core and coil was required to choke down to a given current. Dr. Sumpner thought it better to treat the subject graphically rather than by analysis, and described a construction whereby the fundamental equations could be readily integrated. Prof. Perry said he had reason to think that ordinary hysteresis curves were not applicable to transformers. By analysis of the experimental E.M.F. and current curves, one could work backwards and find the true hysteresis curves.

**Chemical Society, March 3.**—Prof. A. Crum Brown, F.R.S., in the chair.—An address was read, which it is proposed to present to Prof. Bunsen, who has now been for fifty years a foreign member of the Society.—The following papers were then read:—A rule for determining whether a given benzene mono-derivative shall give a meta-di-derivative or a mixture of ortho- and para-di-derivatives, by Prof. A. Crum Brown and Dr. Gibson. If a benzene mono-derivative be converted into a di-derivative by replacement of a second atom of hydrogen in the nucleus by a radicle of the same kind as the one already present, the product may consist either of the meta-di-derivative or a mixture of ortho- and para-di-derivatives. The authors suggest a rule for determining which of these two cases will result in any instance. If the hydride of the radicle employed is directly convertible into the corresponding hydroxide, the meta-di-derivative will be obtained on further substitution by the same radicle. If the hydride of the substituting radicle is not directly oxidizable to the hydroxy-compound a mixture of ortho- and para-di-derivatives will result. For example, when the substituting radicle is chlorine, as in the case of monochlorobenzene, hydrogen chloride not being directly oxidizable to hypochlorous acid, the rule indicates that a mixture of ortho- and para-di-derivatives will be obtained on further chlorination. Nitrous acid is readily converted by direct oxidation into nitric acid, so that on nitration of nitrobenzene, meta-dinitrobenzene alone should be produced if the rule be a correct one. In these, as in the other cases cited by the authors, the rule is found to hold good.—The relative orienting effect of chlorine and bromine; (1) The constitution of parabrom- and parachloro-anilinesulphonic acids, by H. E. Armstrong and J. F. Briggs. Parachlorobromobenzene on sulphonation yields one sulphonic acid,  $C_6H_4Br.Cl.SO_3H$ , possessing the constitution  $Cl:SO_3H:Br = 1:2:4$ . The authors were unable to obtain two sulphonic acids on sulphonating parachloraniline; only one was produced, which separates from its aqueous solution in three distinct forms. This also holds true for the sulphonation of parabromaniline, the sulphonic acids having the constitution  $Cl$  or  $Br:SO_3H:NH_2 = 1:2:4$ .—Note on anhydrides of sulphonic acids, by H. E. Armstrong. When para-dichloro-, chlorobromo-, and dibromobenzene are treated with sulphuric acid containing about 20 per cent. of sulphuric anhydride, sulphonic anhydrides are obtained. These compounds probably owe their formation to the dehydration of the corresponding sulphonic acids first formed.—Contributions to the knowledge of the aconite alkaloids; Part II. The alkaloids of true *Aconitum napellus*, by W. R. Dunstan and J. C. Umney. The roots of true *Aconitum napellus* were extracted with cold fusel oil. The solution so obtained was, after some preliminary treatment, extracted with ether. Two alkaloids were thus extracted, and were separated by means of their hydrobromides into a crystalline and a gummy alkaloid. The former of these was found to be aconitine, whilst the non-crystallizable compound is a new alkaloid which the authors term napelline. This alkaloid is soluble in ether and alcohol, and has a very bitter taste, but does not give rise to the tingling sensation so characteristic of aconitine. Its salts could not be crystallized. By further extraction of the fusel oil with chloroform, aconine was obtained. The roots of true *Aconitum napellus*, therefore, must be held to contain three alkaloids, one of which, viz. aconitine, is crystalline, whilst two are amorphous, viz. napelline and aconine. Indications have been obtained of the presence of a fourth alkaloid, which is amorphous and

closely resembles napelline. Aconitine is by far the most toxic of the alkaloids contained in *Aconitum napellus*.—Contributions to our knowledge of the aconite alkaloids; Part III. The formation and properties of aconine and its conversion into aconitine, by W. R. Dunstan and F. W. Passmore. When pure aconitine is hydrolyzed by heating it with water in closed tubes at  $150^\circ$ , aconine and benzoic acid are obtained in accordance with the following equation—



no picroaconitine or methyl alcohol is obtained at any stage. Anhydro-aconitine is formed by the interaction of aconine and ethyl benzoate at  $130^\circ$ , leaving no doubt that aconitine is benzoyl-aconitine. Aconine yields a crystalline hydrochloride,  $C_{26}H_{41}NO_{11} \cdot HCl \cdot 2H_2O$ , whose specific rotatory power  $[\alpha]_D = -7.71$ . Pure aconine is a hygroscopic, brittle gum, having the composition  $C_{26}H_{41}NO_{11}$ , and the rotatory power  $[\alpha]_D = +23^\circ$ . Its solution reduces Fehling's solution and gold and silver salts. Its aqueous solution is slightly bitter, and gives rise to a burning sensation in the mouth. A crystalline aconitine methiodide,  $C_{26}H_{43}NO_{11} \cdot CH_3I$ , and an amorphous methoxyderivative,  $C_{26}H_{43}NO_{11} \cdot CH_3 \cdot OH$ , have been prepared. A simple laboratory shaking appliance, devised by Prof. Dunstan and Mr. Dymond, was exhibited at the conclusion of this paper.—Note on the carbon deposited from coal-gas flames, by W. Foster. The author quotes analyses of cokes obtained by carbonizing sugar and starch. From the similarity in composition of these cokes to that of the soot obtainable from coal-gas flames, he is of opinion that these substances are all formed by somewhat similar chemical processes.—The volumetric estimation of mercury, by Chapman Jones. The author has devised a modification of the cyanide method of estimating mercury.—Chromic acid, by Eleanor Field. Results are quoted showing that the crystals obtained on cooling with ice a solution of chromium trioxide saturated at  $90^\circ$  consist merely of the trioxide,  $CrO_3$ , and not of chromic acid,  $H_2CrO_4$ , as stated by Moissan.—The origin of acetylene in flames, by V. B. Lewes. The author has sought to determine whether acetylene is the product of high temperature change or of oxidation. The experiments described consisted in passing hydrocarbon gases and mixtures of such gases with others through a heated platinum tube. The results obtained appear to point to acetylene being formed by the action of heat alone.

**Geological Society, March 9.**—W. H. Hudleston, F.R.S., President, in the chair.—The following communications were read:—The new railway from Grays Thurrock to Romford: sections between Upminster and Romford, by T. V. Holmes. In the Hornchurch cutting of the new railway, boulder clay, of which about 15 feet is seen, rests upon the London Clay near the 100-foot contour-line, and is overlain by 10 to 12 feet of sand and gravel. The author gives reasons for inferring that this sand and gravel belongs to the oldest terrace of the Thames Valley gravel occurring in this district, and states that it demonstrates the truth of Mr. Whitaker's conclusion that the Thames Valley deposits are (1-cally) post-Glacial, or newer than the local boulder clay. After the reading of this paper the President said that geologists were much indebted to Mr. Holmes for drawing attention to this interesting section before it was too late. Amongst the many points arising from the discovery of boulder clay at less than 100 feet above Ordnance datum was one as to the probability of the pre-Glacial age of the Thames Valley system. Mr. H. B. Woodward, Mr. H. W. Monckton, Mr. C. Reid, Dr. Hicks, Mr. Lewis Abbott, and Mr. Whitaker also spoke.—The drift beds of the North Wales and Mid-Wales coast, by T. Mellard Reade. This paper is a continuation of papers by the author on the drift beds of the north-west of England and North Wales. The author first treats of the Moel Tryfaen and other Caernarvonshire drifts; he describes the drifts of the coast and coastal plain, connecting his observations with those of the Moel Tryfaen drifts. An important feature of the investigation is the numerous mechanical analyses of the various clays, sands, and gravels. In all the samples but one, a large proportion of extremely rounded and polished quartz-grains have been found, which the author maintains to be true erratics, and a certain sign of marine action. He shows that the Moel Tryfaen marine sands are in part overlain by typical till, composed almost wholly of local rocks with a small percentage of clay, whereas the sands and gravels are full of erratics, including rocks from Scotland and the Lake District, numerous flints, Carboniferous Limestone, and

crystalline schists. Throughout the drifts of the coastal plain he has found a greater or less proportion of granite erratics, as well as, in many cases, minute rolled-shell fragments. He maintains that these drifts are the result of two opposing forces, one radiating from Snowdonia, and the other acting from the sea to the southwards, and their characteristics change as the one or the other force preponderates. The other divisions of the paper are taken up with a description of the Merionethshire drift and that of Mid-Wales, numerous sections being given. Attention is called to a remarkable glaciation of the rocks at Barmouth. In a concluding part, giving inferences and suggestions, the author discusses the land-ice and submergence hypotheses, and concludes that his observations distinctly strengthen the grounds for believing in a submergence of the land to an extent of not less than 1400 feet. An appendix contains details of nineteen mechanical analyses of tills, sands, and gravels, and a bibliography of papers, observations, and theories of the high-level drifts of Moel Tryfaen. The reading of this paper was followed by a discussion, in which Mr. Lampugh, Mr. J. W. Gregory, Mr. H. W. Burrows, the President, and others took part.

**Zoological Society, March 15.**—Prof. W. H. Flower, F.R.S., President, in the chair.—Mr. Sclater exhibited and made remarks on the skin of a Wild Ass obtained by Mr. J. D. Inverarity in Somali-land.—A report was read, drawn up by Mr. A. Thomson, the Society's Head Keeper, on the insects bred in the Insect-house during the past season.—Mr. Seebohm exhibited and made remarks on two pairs of *Picus richardsi* from the island of Tsusima in the Japanese Sea.—Mr. Oldfield Thomas exhibited and described a head (placed at his disposal by Messrs. Rowland Ward and Co.) of the East African *Oryx*. This Antelope, commonly supposed to be *O. beisa*, was shown to differ from that species in possessing long black tufts on the tips of its ears. It was proposed to be called *O. callotis*.—Dr. H. Gadow read a paper on the classification of Birds, in which the results arrived at, after a long study of the structure of Birds for the purpose of completing the part "Aves" of Bronn's "Thierreich," were set forth.—A communication was read from Mr. C. Brunner v. Wattenwyl and Prof. J. Redtenbacher, containing a report on the Orthoptera of the island of St. Vincent, West Indies, collected by Mr. H. H. Smith, the naturalist sent to that island by Mr. Godman, in connection with the operations of the Committee appointed by the British Association and Royal Society for the investigation of the fauna and flora of the Lesser Antilles.—Mr. Oldfield Thomas read a paper on a collection of Mammals from Mount Dulit, in North Borneo, obtained by Mr. Charles Hose. Fourteen species were represented in the collection, of which four were stated to be new to science. Amongst these was a new Carnivore of the genus *Hemigale*, proposed to be called *Hemigale hosei*.—Dr. R. Bowdler Sharpe gave the description of some new species of Timeline Birds from West Africa.

**Entomological Society, March 9.**—Mr. Frederick DuCane Godman, F.R.S., President, in the chair.—Prof. C. Stewart exhibited and made remarks on specimens of *Cystocelta immaculata*, an Orthopterous insect from Namaqualand, in which the female is far more conspicuously coloured than the male, and the stridulating apparatus of the male differs in certain important details from that of other species. A long discussion ensued, in which Dr. Sharp, F.R.S., Mr. Poulton, F.R.S., Mr. Distant, Mr. H. J. Elwes, Colonel Swinhoe, and Mr. Hampson took part.—Mr. Elwes exhibited specimens of *Ribes aureum* which were covered with galls, as to the nature of which the Scientific Committee of the Horticultural Society desired to have the opinion of the Entomological Society. Mr. Fenn, Mr. Tutt, and Mr. Barrett made some remarks on these galls.—Mr. Elwes also exhibited a large number of species of Heterocera recently collected by Mr. Doherty in South-East Borneo and Sambawa. Colonel Swinhoe, Mr. Hampson, and Mr. Distant took part in the discussion which ensued.—Mr. Barrett exhibited a series of specimens of *Noctua festiva*, bred by Mr. G. B. Hart, of Dublin, which represented most of the known forms of the species, including the Shetland type and the form formerly described as a distinct species under the name of *Noctua confusa*. Mr. Fenn and Mr. Tutt made some remarks on the specimens.—Mr. W. C. Boyd exhibited a specimen of *Dianthia Barrettii*, taken at Ilfracombe last summer. It was remarked that Mr. W. F. H. Blandford had recorded the capture of *D. Barrettii*—which had until recently been supposed to be

confined to Ireland—from Pembrokeshire, and that its capture had also since been recorded from Cornwall.—Mr. Tutt exhibited specimens of *Polia xanthomista* from Mr. Gregson's collection, which had recently been sent to him by Mr. Sydney Webb.—Mr. G. A. James Rothney exhibited and read notes on a large collection of Indian ants which he had made in Bengal between 1872 and 1886, comprising some ninety species. He stated that eighteen of these species had been described by Dr. Mayr in his paper entitled "Ameisen Fauna Asiens," 1878; he also said that Dr. Forel had recently identified several other new species in the collection, and that there were about ten species and one new genus which Dr. Forel had not yet determined.—Mr. H. Goss exhibited, for Mr. T. D. A. Cockrell, of Kingston, Jamaica, several specimens of palm leaves, from the garden of the Museum in Kingston, covered with *Aspidiotus articulatus*, Morgan. The leaves appeared to have been severely attacked, the scales entirely covering the upper surface in places.—Mr. F. D. Godman contributed a paper by the late Mr. Henry Walter Bates, with an introduction by himself, entitled "Additions to the Longicornia of Mexico and Central America, with remarks on some previously-recorded species."—The Rev. A. E. Eaton communicated a paper entitled "On new Species of Ephemerae from the Tenasserim Valley."

**Linnean Society, March 17.**—Prof. Stewart, President, in the chair.—Mr. E. M. Holmes exhibited specimens of *Phaclocarpus disciger*, a new species of seaweed from Cape Colony, collected by Dr. Becker near the mouth of the Kowie River. One of the specimens exhibited bore antheridia which have not previously been described in this genus. The species differs from those already known in bearing the organs of reproduction on the surface of the frond instead of on the margin.—Mr. Buxton Shillitoe exhibited and made some remarks upon the flowers of *Leucojum vernum* and *Helleborus viridis*.—On behalf of Mr. Allan Swan, the Secretary read a paper on the vitality of the spores of *Bacillus megatherium*, upon which criticism was offered by Mr. G. Murray.—Mr. S. B. Carill submitted a paper entitled "Notes on Zebras," in which he discussed the position assigned to the zebra in the genus *Equus*; the use and nature of striped coats; the contention that the sailenders on the legs of the *Equide* represent the hoof of the first digit of their polydactyl ancestors; and the evidence bearing upon Prof. Owen's view that the cave horse was in some respects zebrine. He concluded by advocating a systematic attempt to domesticate one or more species of zebra for transport work. Domestication, he considered, would not only render these animals eminently useful, but would be the only means of preserving them from extinction.

## CAMBRIDGE.

**Philosophical Society, March 7.**—Prof. G. H. Darwin, President, in the chair.—The following communications were made:—Some experiments on electric discharge, by Prof. Thomson. A series of experiments were shown in which the electric discharge took place in bulbs without electrodes. It was shown that the colour of the discharge through the same gas varied very greatly with the density of the gas and the intensity of the discharge. This was illustrated by two bulbs, each containing air; the discharge through one was a bright blue, and through the other an apple-green. Another experiment showed the gas at a very low pressure could not act as an electro-magnetic screen, though it did so at a higher pressure. The laws governing the absorption of energy by conductors placed near very rapidly alternating currents were illustrated by experiments which showed that there was much greater absorption of energy by small pieces of tin-foil than large masses of brass or copper.—The capture of Lexell's comet by Jupiter, by the President (Prof. Darwin). The paper contains a more exact estimation of the radius of the sphere of Jupiter's influence than that given by Laplace. If a comet come within this sphere, its orbit will be seriously transformed by the planet. The radius is estimated by the principle that at its boundary the effect of the perturbing force of Jupiter on an orbit round the sun is the same as the effect of the perturbing force of the sun on an orbit round Jupiter. The radius comes out to be '058 times the distance of Jupiter from the sun, Laplace's approximation being '054 times the same distance.—The change of zero of thermometers, by Mr. C. T. Heycock. The author described the result of experiments he had made in conjunction with Mr. Neville to overcome the change in zero which thermometers undergo when heated



for a long time. The method consisted in boiling the thermometers for eighteen days in baths of either mercury or sulphur; at the end of this time the zeros were found to be practically fixed unless they were exposed to higher temperatures than those of the substance in which they were boiled. The paper was illustrated by a curve showing that the change in zero was very rapid for the first few hours, amounting in a special case to 11° C. for twenty hours' heating, but that afterwards the change became almost nil as the heating was continued.—The elasticity of cubic crystals, by Mr. A. E. H. Love.—Changes in the dimensions of elastic solids due to given systems of forces, by M. C. Chree. Expressions are found for the mean values of the strains and stresses in any homogeneous elastic solid, whether æzotropic or isotropic, under the influence of any given system of bodily and surface forces. The expressions for the mean values of the strains, more especially of the dilatation, are employed in determining the changes in the dimensions of elastic solids in a variety of special cases. The effects of gravitational and centrifugal forces are more particularly considered.—On the law of distribution of velocities in a system of moving molecules, by Mr. A. H. Leahy. A short proof is given of the Maxwell law of distribution based upon the principle that a system of molecules, whose velocities are instantaneously reversed, will return to its former configuration. The limit which must be put to the least number of molecules in a gas if the ordinary assumptions of the kinetic theory of gases may be relied upon is also examined, and a note made on the evidence that a system of molecules will ultimately attain to a steady state of distribution.

## EDINBURGH.

Royal Society, March 7.—Prof. Sir W. Turner, Vice-President, in the chair.—Prof. Cossar Ewart read a paper on the cranial nerves of man and Selachians. He compared the cranial nerves of the skate and shark genus with those of man, and discussed their probable identity. The facial nerve of the fish is much more developed than that of any other vertebrate, but is entirely sensory, while in man it is a motor nerve. In some mammals, though not in man, there are vestiges of the lateral sense-organs. These organs occur in the tadpole, but are practically absent in the fully-developed frog. It would seem, therefore, that the mammals originally possessed rudiments of these organs, but that these rudiments disappeared as development proceeded.

March 14.—The Rev. Prof. Flint, Vice-President, in the chair.—Mr. Robert Irvine read a communication, by Dr. John Murray and himself, on the changes in the chemical composition of sea-water associated with marine blue muds. The observations recorded were made on mud dredged from Granton Harbour and from the old quarry near Granton.—Dr. John Murray read a paper, by Mr. Irvine and himself, on manganese nodules in the marine deposits of the Clyde sea-area. Manganese occurs in great quantities in that area, and this forms a striking exception to the usual distribution of manganese as regards depth of water. Dr. Murray, therefore, in a previous paper on this subject, suggested that the large occurrence of manganese in the Clyde area had its origin in the waste products discharged into the river from the manufactories at Glasgow. During the past year a great many dredgings have been taken on the west coast of Scotland and in basins to the north of the Mull of Cantyre, with the result that very little manganese was found, while, as before, large quantities were obtained in the Clyde sea-area—so much so that it would almost pay to dredge it on the Skelmorlie Bank. Dr. Murray's explanation is therefore strongly confirmed.—Dr. Murray exhibited a specimen of extremely pure chalk from Christmas Island (about two hundred miles from the coast of Java).—Dr. Noel Paton read a paper on a case of the occurrence of crystalline globulin in urine.—Prof. Tait read an additional note on the isothermals of carbonic acid at volumes less than the critical volume.

March 21.—The Hon. Lord M'Laren in the chair.—The Keith Prize for the period 1880-91 was presented to Mr. R. T. Omond, Superintendent of the Ben Nevis Observatory, for his contributions to meteorological science; and the Makkdougall-Brisbane Prize for 1888-90 was presented to Dr. Ludwig Becker for his paper on the solar spectrum at medium and low altitudes.—The Astronomer-Royal for Scotland made a further communication on *Nova Aurige*. The atmospheric conditions were remarkably favourable for observation until the 11th day of February, when the star was of the fifth magnitude, but since that time, until the 18th of this month, only occasional observa-

tions were possible. Between the 8th and the 18th no observations were obtained, and the star had meanwhile fallen from the sixth to the ninth magnitude. In the beginning of March it was fully 130 times as bright as it is at present. The spectrum is now nearly continuous throughout with traces of bright lines. Thus *Nova Aurige* presents closer analogies to *Nova Comore* than to *Nova Cygni*, in which an originally continuous spectrum with bright lines changed to a discontinuous spectrum presenting only one bright line close to one of the great nebular lines. One of the lines in *Nova Aurige* is very close to this nebular line, but there is reason to believe that it is due to a substance other than that which gives the nebular line.—Dr. R. H. Traquair read a paper on the fossil Selachii of Fife and the Lothians. Five new species are included.

## GLASGOW.

Geological Society, March 10.—Mr. Dugald Bell read a paper on the alleged submergence in Scotland during the Glacial epoch, with special reference to the so-called "high-level shell-bed" at Chapelhall, near Airdrie, 512 feet above the sea. This "bed" had first been brought into notice by Mr. Smith, of Jordanhill, in a paper to the Geological Society in 1850, and had since been generally accepted as proving a submergence of the land to at least that extent. Its existence, however, rested on very imperfect evidence. It was said to have been found in digging a well near the summit of one of the high ridges of boulder-clay in the district; and was described as a bed of fine reddish clay, about 2 feet thick, and thinning away rapidly on all sides, lying in a hollow of the boulder-clay, which was 14 feet or more in thickness both above and below it. The well seems to have been built up before Mr. Smith had an opportunity of examining the section, though he got some shells said to have been found in the clay, and which were all of one species, *Tellina calcarata*. From that day to this no geologist had seen the clay, though it had been sought for all around, and though another well had been sunk within a few yards of the old one, in the hope of finding it. At the very utmost, it seems to have been a limited strip or patch of shelly clay, intercalated in the boulder-clay, such as had been found in many other localities, and could not fairly be taken as a sufficient proof of submergence. The more they were considered the greater seemed the improbabilities which the theory of a submergence and re-emergence of the country to this extent, and at that time, involved. There was not a particle of corroborative evidence. No shells had been found at a similar level in other parts of the midland valley, nor in the numerous side-valleys, where they would be more likely to be preserved than on this exposed knoll in the centre. None had been found in the upper boulder-clay, which, if all this valley had been a sea-bottom before the "second glaciation," should contain abundance of at least shelly fragments. Further, a "mild interglacial period" would probably accompany such a submergence, and this shelly clay was supposed to have been laid down during such a period; but the only species of shells found in it indicated, not mild, but extremely cold conditions. In face of all these difficulties, it was suggested that the layer containing these shells may have been transported (probably in a frozen condition) by the ice-sheet, as in many other instances that were well known. This seemed to be by far the more probable account of it, and got rid of the complications connected with a first glaciation, a deep submergence, a re-emergence, and a second glaciation closely resembling the first. The position of this patch of shelly clay, admittedly in the track of the old ice-sheet, and in front of an obstruction presented by the highest rising ground in the district; the highly Arctic character of the organisms; the very colour of the clay (as reported) being different from the clays of the immediate neighbourhood,—all favoured this conclusion. This Chapelhall clay, therefore, he submitted, ought no longer to be cited as a proof of submergence. An animated discussion followed.

## PARIS.

Academy of Sciences, March 21.—M. d'Abbadie in the chair.—A study of the properties of amorphous boron, by M. H. Moissan. A full account is given of the physical and chemical properties of pure amorphous boron. The following conclusions are arrived at by the author:—Boron combines more readily with the metalloids than with the metals; it has a great affinity for fluorine, chlorine, oxygen, and sulphur. At a red heat it displaces silicon and carbon from their oxides. It

combines with nitrogen directly only at a very high temperature ; it readily reacts with a large number of salts. Its action on metallic oxides, easily reduced by carbon, is very violent. (See p. 522).—On the preparation of boron iodide, by M. H. Moissan.—On the origin of colouring matters in the vine; the ampeleochroic acids and the autumnal coloration of vegetation, by M. Arm. Gautier.—Experiments on vascular reflex action, by M. L. Ranvier.—Contribution to the history of morbid associations: coexistence of stercorary retention with general diseases and injuries of the great viscera, the kidneys in particular, by M. Verneuil.—Surface and population: European States, by M. Émile Levasseur. The following values have been taken from the tables given:—

States.	Surface, in thousands of square kilometres.	Population, in millions of inhabitants at the end of 1890.	Density, or number of inhabitants per square kilometre.
West Europe ...	916'32	87'11	95'0
Central " ...	1207'56	93'609	77'0
South " ...	1450'565	71'826	50'0
East " ...	5477'0	98'0	18'0
North " ...	983'0	9'1	9'0
Total ...	10,034'445	359'645	35'8

The methods of arriving at these numbers and other information relating to them are fully explained.—Report on a memoir, presented by M. Blondot, on the propagation of Hertz vibrations.—Observations of comet a 1892 (Swift), made at the Paris Observatory with the West Tower equatorial, by M. G. Bigourdan.—Observations of comet z 1892, made at the Paris Observatory with the same instrument, by the same author.—Observations of Swift's comet (1892 March 6), made with the great equatorial of Bordeaux Observatory, by M. G. Rayet.—On the common periodicity of sun-spots and auroræ, by M. Terby. (For the last four communications see Our Astronomical Column).—On the tensions of saturated vapours of different liquids at the same pressure, by M. Edmond Colot. The experiments made by the author bear out the law that between the temperatures  $t$  and  $\theta$  of the saturated vapours of any two liquids which correspond to the same pressure, there exists the linear relation  $t = A\theta + B$ , where  $A$  and  $B$  are two constants, the values of which depend on the nature of the liquids under consideration.—On a standard condenser, by M. H. Abraham. With a view of making a new determination of  $\nu$ , M. Abraham has constructed an air condenser having a capacity of about 500 in electro-static C.G.S. units. The arrangement is described, and estimations are given of the probable accuracy which can be attained. The ratio of the electro-static to the electro-magnetic unit ( $\nu$ ) has not yet been found.—On electro-capillary phenomena, by M. Gouy.—On the manifestation of negative electricity during fine weather, by M. Ch. André. During fine weather a negative electrification of the air is extremely rare. Several theories have been put forward to account for this, but an examination of some of the records of atmospheric electricity, made at the Lyons Observatory, leads M. André to conclude that the appearance of negative electrification during fine weather is an exaggeration of a diurnal variation of which it is a particular case.—Crystalline absorption and the choice between the different theories of light, by M. E. Carvallo. If a ray of monochromatic light traverse a double-refracting crystal, the absorption only depends on the position of the Fresnel vibration. The intensity of the emergent ray is given by M. Becquerel's formula—

$$\sqrt{I} = \sqrt{I_0} (e^{-\alpha x} \cos^2 \alpha + e^{-\beta x} \cos^2 \beta + e^{-\gamma x} \cos^2 \gamma),$$

where  $I_0$  is the intensity of the incident ray;  $I$ , the intensity of the emergent ray;  $\alpha, \beta, \gamma$ , angles between Fresnel's vibration and the axes of optical elasticity;  $x$ , the thickness of the crystal traversed by the ray; and  $e_x$  the base of Napierian logarithms. The author finds that this law is verified in the important case where only one of the three components exists. It also applies to heat rays. Finally, when an extraordinary ray traverses tourmaline in a direction oblique to the axis, its state of polarization varies progressively until the thickness traversed is that which would destroy the ordinary ray. This state then remains invariable up to emergence, when the ray sharply regains the state of original polarization.—On the determination of chemical equilibrium in solution systems, by M. Georges Charpy.—Combinations of cuprous iodide with ammonium thiosulphate, by M. E. Brun. The following com-

pounds have been obtained:  $\text{Cu}_2\text{I}_2 \cdot 2\text{NH}_4\text{I} \cdot 8(\text{NH}_4)_2\text{S}_2\text{O}_8$ ;  $4\text{Cu}_2\text{I}_2 \cdot \text{Cu}_2\text{S}_2\text{O}_8 \cdot 7(\text{NH}_4)_2\text{S}_2\text{O}_8 \cdot 4\text{H}_2\text{O}$ ; and  $\text{Cu}_2\text{I}_2 \cdot (\text{NH}_4)_2\text{S}_2\text{O}_8 \cdot \text{H}_2\text{O}$ . The author proposes to study similar compounds yielded by sodium and potassium thiosulphates, and also compounds given by other iodides, such as those of silver and lead.—Study of the velocity of decomposition of diazo compounds, by MM. J. Hausser and P. Th. Muller.—Some bases homologous with quinine, by MM. E. Grimaux and A. Arnaud.—The essence of *Licari kanali*, by M. Ph. Barbier.—Combinations of the fatty acids with the ethylene series of hydrocarbons, by MM. Bèhal and Desgrez.—On the natural synthesis of the vegetable hydrocarbons, by M. Maquenne.—On the presence, in straw, of an aerobic ferment reducing nitrates, by M. E. Bréal.—On the hereditary transmission of acquired characters by *Bacillus anthracis* under the influence of a dysgenic temperature, by M. C. Phisalix.—On the nitrogen in the blood, by MM. F. Joyet and C. Sigalas.—Anatomy of the hypogastric nervous system of mammals, by M. Lanegrace.—On the Pliocene bird fauna of Roussillon, by M. Ch. Depéret.—The sickle at the end of the Stone Age, by M. Émile Cartailhac.—On the régime of artesian wells in the El Golea region, by M. Georges Rolland.—On a particular cause of contamination of water having its source in limestones, by M. E. A. Martel.

BOOKS, PAMPHLETS, and SERIALS RECEIVED.

BOOKS.—Travels amongst the Great Andes of the Equator, and Supplementary Appendix to ditto: E. Whymper (Murray).—Diagram illustrating the Leblanc Soda Process, and Key to ditto: J. J. Miller (J. Heywood).—Dictionary of Political Economy: Edited by R. H. I. Palgrave, Part 2 (Macmillan).—Bibliothek des Professors der Zoologie und Vergl. Anatomie, 1891: Dr. L. von Graaf (Leipzig, Engelmann).—The Universal Atlas, Part 13 (Casell).—Le Climat de Rio de Janeiro: L. Cruls (Rio de Janeiro).—The World and the Flood: A. J. Stuart (Shanklin).  
PAMPHLET.—The French Peasantry since the Revolution of 1789: L. Nottelle (Simpkin).  
SERIALS.—Quarterly Journal of Microscopical Science, No. 131 (Churchill).—Bulletin de la Société Astronomique de France, cinq. année, 1891 (Paris).

CONTENTS.

	PAGE
A Zoologist on a Disease. By Prof. E. Ray Lankester, F.R.S.	505
Two Books of African Travel	507
Professor Tyndall's Latest Book. By J. D. E.	508
Our Book Shelf:—	
Roscoe and Schorlemmer: "A Treatise on Chemistry," Vol. III. Part VI.	509
Ward: "The Oak: a Popular Introduction to Forest Botany."—J. G. B.	509
Levett and Davison: "The Elements of Plane Trigonometry"	509
De Vilmorin: "Les Fleurs à Paris: Culture et Commerce"	510
Buckland: "Health Springs of Germany and Austria"	510
Letters to the Editor:—	
Heat-Engines and Saline Solutions.—Lord Rayleigh, Sec. R.S.	510
On Earth Vibrations.—Dr. Emil Oddone	510
Striated Surface under the Cromer Drift.—William Sherwood	511
Pilchards.—Matthias Dunn	511
On the Boltzmann-Maxwell Law of Partition of Kinetic Energy.—Rev. H. W. Watson, F.R.S.	512
The Functions of Universities.—Prof. Geo. Fras. FitzGerald, F.R.S.	513
A New Comet.—W. F. Denning	513
On Insect Colours. I. By F. H. Perry Coste	513
Notes	517
Our Astronomical Column:—	
The Planet Jupiter	521
The Objective Prism	521
Variation of Latitude	521
The Discovery of Neptune	522
Astronomy at the Paris Academy, March 21	522
Variability of Nebulæ	522
Solar Prominence Photography	522
The Aurora Spectrum	522
The Properties of Amorphous Boron. By A. E. Tutton	522
The Manchu Race	523
Societies and Academies	524
Books, Pamphlets, and Serials Received	528

THURSDAY, APRIL 7, 1892.

## MENDELÉEFF'S PRINCIPLES OF CHEMISTRY.

*The Principles of Chemistry.* By D. Mendeléeff. Translated from the Russian (Fifth Edition) by George Kamensky, and edited by A. J. Greenaway. Two Vols. (London: Longmans, Green, and Co., 1891.)

ALL English-speaking chemists will cordially welcome the appearance of this book, if for no other reason than because its author in its preparation was led to the recognition of that fundamental principle of chemistry with which his name will always be associated—the principle which is embodied in what is now known as the periodic law. This fact alone would serve to stamp the book as one of the classics of chemical science. But, even apart from this circumstance, the work has very remarkable, and, indeed, exceptional, merits. Probably no scientific treatise ever more strikingly reflected the personality of its author. We have absolutely nothing like it in our language. In grasp of principles, in philosophic breadth, in copiousness of detail, in richness of speculation and suggestion, it is altogether unique among chemical manuals. Every true and earnest student of chemistry is certain to be profoundly influenced by it, even if he cannot always bring himself to subscribe to its doctrine. Of course, the facts are, for the most part, those which are common to all the larger treatises on systematic chemistry, but these are set out and marshalled in a manner wholly original. The intent and purpose of the book is to demonstrate the broad general principles on which chemistry as a science rests. This, it may be urged, is the intent and purpose of every chemical treatise. It may be so, but in many cases the philosophy is lost sight of—obscured, indeed, by the facts, just as the houses may obscure the view of the village.

In Mendeléeff's work experimental and practical data have their place, but only as means to an end, and that end is as evident on every page as it was in Dalton's immortal work. Fascinating as the book is, it must be admitted that it is by no means easy reading; and he who wishes to master its contents and to assimilate its teaching will need to gird up his mental loins. Part of the difficulty is doubtless due to the different genius of the languages, but much more depends upon the impossibility of entering into the spirit of an author, or of quickly realizing his drift and meaning, when his whole mode of thought is so very dissimilar to that which obtains among Western people. It may be that herein lies part of the peculiar charm of freshness of the work. The book of the Siberian chemist is to the ordinary run of text-books what the novels of Tolstoi or Turgenieff are to the common run of works of fiction. But there are difficulties of another kind. Probably no other book in our language—certainly no other chemical treatise—contains such an extraordinary number of footnotes. There is scarcely a page without a footnote, and some of the pages are practically little else than footnotes. The continuity of description or of argument is constantly being broken, often by a footnote

extending over several pages, and frequently so diffuse and involved that, by the time the reader has disposed of it, the statement in the main text to which it had reference has been lost sight of, and must needs be picked up again. Moreover, the repeated interruption is aggravated by the circumstance that these notes are printed in "nonpareil small," which adds enormously to the physical fatigue of reading and studying the work. The author, indeed, recommends that they should be read only by the advanced student, or on a second perusal of the work; but we are afraid that no intelligent reader will follow this advice when once he has begun to dip into them. They are, in fact, like the postscripts of ladies' letters—often more important, more instructive, more suggestive, and more characteristic, than the main body of the text. But, in truth, the book is not fitted for a beginner: its proper readers are those for whom the footnotes are specially intended. It requires, too, to be read with discrimination. It was said by Davy that analogy is the fruitful parent of error, and it must be confessed that Mendeléeff's love of analogy frequently leads him to generalizations which are more ingenious and suggestive than intrinsically sound or well grounded.

The translator and the editor have, doubtless, had difficulties to contend with. They tell us that they have not considered themselves at liberty to make any alterations in the matter of the work, and they have striven to give a literal rendering of it. They have felt that, on the whole, it would be better to have some inelegance of language rather than risk the loss of the exact shade of the author's meaning. Unfortunately, in too many instances the translator and his editor have not gained in precision of meaning what they have lost in elegance of statement. Thus, for example, on p. 12 we read:

"The means of collecting and investigating gases were already known before Lavoisier's time, but he first showed the real part they [the means or the gases?] played in the processes," &c.

On p. 19 it is stated:

"By heating chalk (or else copper carbonate . . .) we obtain lime," &c.

Thus, too, on p. 47:

"In general terms water is called pure when it is clear and free from insoluble particles held in suspension and visible to the naked eye, from which it may be freed by filtration through charcoal, sand, or porous (natural or artificial) stones, and when it possesses a clean fresh taste. It depends [what depends?] on the absence of any tastable, decomposing organic matter, on the quantity of air and atmospheric gases in solution, and on the presence of mineral substances to the amount of about 300 grams per ton (or cubic metre, or, what is the same, 300 milligrams to a kilogram or litre of water), and of not more than 100 grams of organic matter."

Again, on p. 72 we read:

"Although in the majority of cases the solubility of solids increases with the temperature, yet, just as there are substances whose volume diminishes with a rise in temperature (for example, water from 0° to 4°), so there are not a few solid substances whose solubilities fall on heating. Glauber's salt, or sodium sulphate, historically

forms a particularly instructive example of the case in question. If this salt be taken in an ignited state (!) (deprived of its water of crystallization), then its solubility," &c.

What, too, is the meaning of the statement on p. 83?

"Under ordinary circumstances the quantity of aqueous vapour [in the air] is much greater [than what?], but it varies with the moisture of the atmosphere."

Presumably, for "moisture" we are to read "temperature." On p. 164, in the description of the experiment of burning phosphorus in oxygen, it is recommended that "the cork closing the vessel should not fit tightly, otherwise it may fly off with the spoon." That the cork should fly off with the spoon is contrary to well-established precedent: if anything is to fly away with the spoon, it should, of course, be the dish on which the bell-jar is represented as resting. To say (p. 417) that common salt containing magnesium chloride "partially effloresces in a damp atmosphere" is opposed to fact, and was surely never so stated by Mendeléeff. Van der Waals's equation is written:

$$\left(p + \frac{a}{v^2}\right)(v - \beta) = R(1 - at),$$

instead of

$$\left(p + \frac{a}{v^2}\right)(v - \beta) = R(1 + at).$$

And on the same page we find  $\beta r = c(1 + at)$ , instead of  $\beta v = c(1 + at)$ .

Proper names are frequently wrong. Thus we have "Van der Waal" for van der Waals, "Becker" for Becher, "Brown" for Braun, "De Haen" for De Heen, "Frauenhofer" for Fraunhofer, "Personne" for Person, "Prout" for Proust, "Ray" for Rey, "Krütznach" for Kreutznach, "Wergtesgaden in Salzkammerhutte" for Berchtesgaden (which is not in the Salzkammergut).

We have taken the pains to compare the English version with the German translation of Jawein and Thillot in a number of instances where the meaning is obscure, or where statements are made which appear to be erroneous, and in no single instance is the fault to be traced to the author. We think, too, that the limitation imposed on the translator and editor by themselves has operated injuriously in another way: in cases where subsequent research should modify or supplement particular statements in the original, it was surely open to them, in the interests of knowledge, to substitute truth for error. Thus we know from the work of Winkler and Hempel the conditions under which exact determinations of oxygen by means of alkaline pyrogallol can be made; we know, too, that atmospheric ammonia and nitric acid are not by any means the main sources of the supply of nitrogen to plants; ammonium chloride is not now usually prepared by sublimation. The statement of the principle of Kjeldahl's method, given on p. 246, is inaccurate: the radicle ammonium has not been obtained, nor is the old view of the nature of the so-called "ammonium amalgam" any longer tenable, nor is there any direct proof of the existence of ammonium hydrate. Flagstone, at least in this country, is not a form of carbonate of lime: it is usually a fine-grained micaceous sandstone. The apparatus employed by Cavendish in his memorable synthesis of water in no wise resembled

that described and figured on p. 167; thanks to the symbol adopted by the publishing Society which bore his name, it seems now well-nigh impossible to get rid of the belief that the pear-shaped stoppered eudiometer was devised and used by him in the course of his investigation: as a matter of fact, the explosions were made in a simple Volta tube. With respect to the illustrations in general, we think that the majority of them could well have been spared; all of them have done duty in other works, and many of them are calculated to give an erroneous impression of the thing sought to be represented. Thus the coke-tower figured on p. 443 resembles nothing actually used; Fig. 60, which is stated to be a Davy lamp, is either a Mueseler or a Clanny lamp; Fig. 47 does not illustrate the method of preparing nitric acid employed in this country, nor does Fig. 93 represent a modern blast-furnace. The only figure of a zinc-furnace given is that of the practically obsolete *per descensum* method.

We have been constrained to point out these blemishes, not in any hypercritical spirit, but solely because of our wish that Mendeléeff's great work should have been given to English and American readers in as perfect a form as possible. The blemishes, after all, are only as the spots on the sun. It is a great boon to get the book even as it is, for no thoughtful reader can fail to be quickened and animated by its fruitful and suggestive pages.

T. E. T.

#### THE LIGATION OF THE GREAT ARTERIES.

*A Treatise on the Ligation of the Great Arteries in continuity, with Observations on the Nature, Progress, and Treatment of Aneurism.* By Charles A. Ballance, M.B., M.S. Lond., F.R.C.S., and Walter Edmunds, M.A., M.C. Cantab., F.R.C.S. (London: Macmillan and Co., 1891.)

THIS work is the result of investigations carried out by the authors during the last seven years, and contains the results of long and careful study. The authors were evidently desirous of getting to the bottom of their subject, and in their endeavours to do so, have used every method of research at their disposal.

The first chapter is devoted to a short account of hæmorrhage in man, and contains valuable statistics as to the results of the ligation of the main arteries. This part will, of course, prove of the greatest interest to the pure surgeon. The second chapter contains a paragraph on the necessity of experiments on animals for the purpose of studying the mechanism of hæmorrhage; this paragraph might well have been omitted in a book written for the professional and scientific public, who are already convinced of the necessity of pathological experiments if pathology is to make any advance at all. The greater part of this chapter, however, is full of valuable facts concerning the occurrence of the disease of arteries in animals; whilst in the third chapter the structure of arteries is described, and, in this connection, the experiments made by the authors on the longitudinal tension of arteries require special mention.

Physiological occlusion and pathological obliteration of

arteries are discussed in the next two chapters, and the authors point out that in physiological occlusion, Nature does not think it necessary to rupture the two inner coats of the artery, and that she does not divide the artery to reduce the longitudinal tension. In pathological obliterations, likewise, the rupture of the coats is by no means essential to occlusion, and, the coats not being ruptured, hæmorrhage does not occur.

In 1889, Messrs. Ballance and Sherrington published in the *Journal of Physiology* a valuable paper on the formation of scar-tissue, which has been practically re-copied into this book. The authors have made use for their experiment of Ziegler's method of placing glass-chambers under the skin of animals, and examining their contents at various intervals after their introduction. Messrs. Ballance and Sherrington have been unable to trace the development of the so-called plasma-cells from the ordinary cell-forms of blood and lymph, and incline towards the opinion that plasma-cells are derived from the connective-tissue elements, and ultimately develop into fibrous tissue.

I cannot help thinking that Ziegler's method is by no means satisfactory when the object in view is to study the formation of cicatricial tissue; for in such investigations the most important point is that all the tissues to be examined should be removed intact, and examined after fixation. It is impossible to do this with glass-plates, but satisfactory results may be obtained by introducing soft material, such as filter-paper. The surrounding tissues and the paper can then be removed, and serial sections made through the whole. The examination of preparations made in this way make it doubtful whether Messrs. Ballance and Sherrington's views are correct, and would rather lead me to believe that the plasma-cells are originally derived from leucocytes.

Messrs. Ballance and Edmunds proceed to investigate the conduct and fate of the coats and of the ligature, and it is clear that they have taken immense trouble in ascertaining, by experiments on animals, how quickly a ligature becomes absorbed after being applied. Numerous and beautifully-executed plates, show the microscopical and macroscopical appearances of ligatures made of tendon, silk, floss-silk, silkworm gut, &c., at varying intervals after their application to blood-vessels in man and animals; whilst special chapters are devoted to the ligature, of the knot, of the force used in the tying, &c. It may be noticed that the authors describe a new form of knot, which they recommend, and to which they give the name of stay-knot, whilst the old-fashioned reef-knot is entirely discarded. Moreover, the authors condemn in no uncertain terms the practice of rupturing the coats of arteries during, and the division of vessels after, ligature—points of the greatest practical importance.

The other chapters on the operation and the fate of the patient are of clinical interest chiefly; but special mention should be made of excellent chapters on supuration occurring after ligation, and on the pathology of hæmorrhage, as well as of the full account of the experimental investigations made by Messrs. Ballance and Edmunds. It is only right to mention that most of the experiments were made at the Brown Institution.

The book is beautifully printed, and profusely illustrated with 10 plates and 232 figures. It will be widely read

by all surgeons, histologists and pathologists, and forms a most valuable addition to surgical and pathological science.

M. ARMAND RUFFER.

#### OUR BOOK SHELF.

*Precious Stones and Gems: their History, Sources, and Characteristics.* By Edwin W. Streeter, F.R.G.S., M.A.I. Fifth Edition. (London: George Bell and Sons, 1892.)

BOOKS dealing with the fascinating subject of precious stones naturally fall into three classes—mineralogical treatises, archeological essays, and works adapted for experts and commercial men. Among the last class, the well-known work above cited, which has now reached a fifth edition, takes a prominent place. The enterprise and energy of the author in seeking out and developing new sources of ornamental stones is well known, and many of the facts contained in the present volume have been collected or verified by Mr. Streeter himself, by his sons, or by their agents. The chapters, which in earlier volumes were devoted to the description of famous diamonds, and to pearls and pearl-fishing, are now omitted, these subjects having been dealt with in separate books from the author's pen, the space thus obtained being devoted to an account of the Ruby Mines of Burma, the sources of sapphire in Siam and Montana, and those of the emerald in Egypt. In all these cases Mr. Streeter's agents have taken an active part in the work of exploring the districts, and he is able to furnish much information not hitherto available to the public. While the commercial aspects of these gem-stone localities naturally receive the greatest amount of attention, it is only fair to the author to point out that much care has evidently been exercised in order to prevent the creeping in of those errors on scientific points which too often disfigure works of this class. The author acknowledges in his preface the assistance which he has received from Mr. Rudler, the Curator of the Jermyn Street Museum, in dealing with scientific questions. The new edition, like its predecessors, is admirably got up and well illustrated.

*Air and Water.* By Vivian B. Lewes, F.I.C., F.C.S., Professor of Chemistry, Royal Naval College, Greenwich, &c. (London: Methuen and Co., 1892.)

THIS little book is one issued in connection with a series of University Extension manuals. The author may be congratulated upon the selection of his subject, which is one of those capable of being adequately treated in a course of a dozen lectures; and he has been no less happy in his treatment of it, for by following the historical method he has succeeded in maintaining the interest of his readers, while he fairly covers the whole ground with which an elementary treatise on this topic may be expected to deal. The story of the researches of Galileo, Torricelli, and Pascal, of Priestley, Cavendish, and Lavoisier, is followed by an admirable *résumé* of the latest achievements of chemical science, and this in turn by a clear statement of the problems involved in the maintenance of proper supplies of fresh air and pure water. The warmest votaries of other branches of science will not quarrel with our author when, in his enthusiasm, he declares chemistry to be the "most beautiful of the sciences"; possibly, however, some may demur to the statements in the following passage: "Although the amount of oxygen present in the air amounts to 1,233,010 billions of tons, still it is only one two-millionth of the total oxygen, and had not this small fraction been left over in the creation of the world, neither animal nor vegetable life could have existed." The author must hold very decided views as to how far down extends that condition of oxidation which is so constantly found at the earth's surface.

## LETTERS TO THE EDITOR.

[The Editor does not hold himself responsible for opinions expressed by his correspondents. Neither can he undertake to return, or to correspond with the writers of, rejected manuscripts intended for this or any other part of NATURE. No notice is taken of anonymous communications.]

## Ornithology of the Sandwich Isles.

It is easy to make assertions which, however improbable, it is not easy to disprove. I would therefore invite Mr. Albert F. Calvert to furnish documentary evidence of those he has advanced (*supra*, p. 485). They do not indeed materially affect what I had said; yet, for the sake of accuracy, it might be as well to know on what foundation they rest. Those who are interested in the growth of ideas will be pleased to find that Sir Joseph Banks was so far in advance of his time as, on his return from his voyage with Captain Cook, which ended in 1771, to have "several cases of birds carefully mounted and arranged according to the localities in which they were collected"; and, among them, a "group of land birds from Owhyhee"—an island which Cook did not discover until 1778—on seven years later. As these assertions alone concern the subject on which I wrote, I refrain at present from offering any remarks on the others; but your correspondent seems to have been the victim of a delusion or something worse.

ALFRED NEWTON.

I OBSERVE in NATURE (p. 485) a letter from Mr. Albert F. Calvert, in which he states that certain cases of birds, which were collected by Sir Joseph Banks during his voyage in the *Endeavour* with Captain Cook, "were in the custody of the Linnean Society of London until 1863, when they formed part of their natural history sale."

This is not the fact. The birds belonging to Sir Joseph Banks were never in the possession of this Society. It is true that the Society at one time possessed the insects and shells which formed part of the Banksian collections, and these in 1863 were presented, not sold, to the Trustees of the British Museum. Had there been any birds, they would doubtless also have been presented at the same time.

Where, then, did the cases, which Mr. Albert F. Calvert says are still "carefully preserved in the museum of his ancestor Mr. John Calvert," come from? Certainly not from the Linnean Society. In view of Prof. Newton's valuable communication to NATURE (March 17, pp. 465-69), it is of importance that this inquiry should be answered, and a list furnished of the species contained in these cases, the reported existence of which will agreeably surprise ornithologists.

As Mr. A. F. Calvert has disclosed a source of information likely to be useful, perhaps he may be able to answer another question.

In 1860 the late Mr. J. D. Salmon, a well-known oologist, bequeathed to the Linnean Society a valuable collection of birds' eggs. This collection was known to contain the eggs of many British birds which were then becoming scarce, and have since become still rarer, if not quite extinct as breeding species; such, for example, as the golden eagle, osprey, kite, buzzard, honey buzzard, raven, chough, dotterel; and amongst some of the rarer species not found breeding in Great Britain, the spotted eagle, gerfalcon, black kite, rough-legged buzzard, Lapp owl, &c., and, above all, an egg of the great auk (*Alca impennis*), the value of which alone would almost equal that of all the other eggs in the collection.

I am informed that on the death of Mr. Salmon this collection was intrusted by his executors, for the purpose of being catalogued, to someone known to Mr. A. F. Calvert's ancestor; and by some accident, when it came to be handed over to the Linnean Society, the egg of the great auk was (some time afterwards) found to be missing, as also the eggs of certain species above mentioned, with several others that might be named.

Possibly they may have been removed at the time for safe custody, and were forgotten to be returned when the collection was deposited in its present resting-place.

Perhaps Mr. A. F. Calvert will say whether by chance these eggs (like the Banksian birds) have been "carefully preserved in the museum of his ancestor." If so, I presume that, on proof of the bequest of the collection to the Linnean Society, and proper identification of the eggs by their numbers, initials, or other

marks, Mr. A. F. Calvert would be willing (on behalf of his ancestor) to restore them to the cabinet from which they have been so long missing.

J. E. HARTING.  
Linnean Society, Burlington House, March 28.

## Poincaré's Thermodynamics.

It is clear that I was justified in attributing the gist of M. Poincaré's first letter to his not having sufficiently read my notice of his book. He has not even yet fully apprehended the bearings of that notice, as a few words will show. Far from being unable to uphold any one of my critical remarks, as M. Poincaré is pleased to hint may be the case, I reassert every one of them, and could easily add to their number.

Let us begin with the particular item of my criticism which M. Poincaré persists in regarding as the most important. My words were:—"in his assumed capacity [of pure analyst] he quite naturally looks with indifference, if not with absolute contempt, on the work of the lowly experimenter." As an illustration of this I instanced M. Poincaré's ignorance of the thermo-electric researches of Sir W. Thomson, Magnus, &c. Then I quoted (in full) two of his remarks on the "Thomson effect." In the first of these he used the very peculiar phrase

"Sir W. Thomson admet qu'il existe une force &c."—and in the second he said

"si l'effet Thomson a pu être mis en évidence par l'expérience, on n'a pu jusqu'ici constater l'existence des forces électromotrices qui lui donnent naissance."

To these he has, in his recent letters, added other like statements. Now, as I understand the matter, Lord Kelvin *proved* (which, as I take it, means a good deal more than might be implied by "constater") the existence of the electromotive force which depends on the so-called "Thomson effect" (giving also thereby the means of measuring its amount) by showing that the Peltier electromotive force does not in general fully account for the observed current in a thermo-electric circuit, and may even be directly opposed to it; while no other source of electromotive force can exist save the gradation of temperature in one or both of the metals. He then proceeded, by experiment, to measure the amount of the "Thomson effect" for unit current in various metals, unequally heated. When the passages above quoted from M. Poincaré's work are compared with the facts just stated, my comments on them will be seen to be fully justified.

It is necessary to add that I made *no reference whatever* to M. Poincaré's distinctions between "true" and "apparent" electromotive force:—simply because I regard these, along with many other celebrated terms such as "disgregation" &c., as mere empty names employed to conceal our present ignorance.

As to the three chief objections I made to the work of M. Poincaré, every one (author, critic, or onlooker) is entitled to form and express his opinion. I need not restate mine, though I continue to adhere to every word of it;—but I may make the following additional remarks on these objections severally.

1. What sort of title to completeness can be claimed for a Treatise, on Thermodynamics, in which no mention is made of the grand principle of Dissipation of Energy; nor of Thermodynamic Motivity, "that possession the waste of which is called Dissipation"?

2. With regard to the measurement of Absolute Temperature, what I *did* say was that the experiments of Joule and Thomson, which justified them in basing it on Carnot's Function, were not mentioned by M. Poincaré in *this connection*. The omission by M. Poincaré of the italicized words makes an absolutely vital change in the meaning of my statement; and enables him to make what, (at first sight only), appears to be an answer to it.

3. As regards the foundation of the Second Law, it is unfortunately clear that M. Poincaré and I must continue to differ:—so that further discussion of this point would be unprofitable. For I presume that M. Poincaré has not formed his opinion without careful study of all that Clerk-Maxwell said on the point:—so that even a perusal of Lord Kelvin's latest paper (*Fortnightly Review*, March 1892) is not likely to induce him to change it.

P. G. T.

26/3/92.

## M. Poincaré and Maxwell.

In his recent treatise on "Électricité et Optique," M. Poincaré professes to give a description of Maxwell's theories of electro-

magnetic actions. M. Poincaré appears to think that Mossotti's theory is consistent with and differs but little from Maxwell's. On this Maxwell says (§62):—"The theory of direct action at a distance is mathematically identical with that of action by means of a medium . . . provided suitable hypotheses be introduced when any difficulty occurs. Thus Mossotti has deduced the mathematical theory of dielectrics from the ordinary theory of attraction." Maxwell anyway repudiated Mossotti's theory. M. Poincaré introduces a "fluide inducteur" as the name of a thing displaced in the dielectric, when what Maxwell calls electric displacement occurs. This is all very well. It is anyway not inconsistent with Maxwell, even though Maxwell says distinctly that he does not know what the change of structure is like which he calls electric displacement. It might be a bending or twisting or lots of things, but M. Poincaré is partially justified in fixing the idea thus. He calls this "fluide inducteur" elastic, though at the same time he calls it incompressible. It is not quite clear what "fluide" means here. M. Poincaré certainly observes that the elasticity of the "fluide inducteur" is quite different from that of material bodies, and in fact acknowledges that it is such as can hardly be fairly attributed to an incompressible fluid. Indeed, how can an incompressible fluid be elastic at all? There must be *something* besides the fluid; there must be some structure fixed in space which offers an elastic reaction to the fluid when driven past it, or else there must be the two liquids he objects to that are driven past one another. It is hardly a fair representation to talk of an *elastic incompressible fluid*, and then to invent difficulties, when the phenomena could not confessedly be represented by any such thing, but only by a fluid with some other mechanism superadded.

M. Poincaré's statement, "La méthode précédente n'est pas la seule que l'on puisse employer pour déduire de la théorie de Maxwell les lois de la distribution électrique," coupled with his further statement of "une autre méthode . . . sans supposer l'existence de ce fluide," seems at variance with his implication that this elastic incompressible fluid is part of or involved in Maxwell's theory.

This leads to the question of how far Mossotti's theory can fairly be considered as a substitution for or as a development of Maxwell's. It does not in any real sense get over action at a distance. There are the horrid old electrical charges acting upon one another across a space full of some non-conducting medium. This is practically no advance as far as a theory of electrical action is concerned. It is an advance no doubt as far as the behaviour of the medium is concerned, inasmuch as it enables a time propagation through space to occur; but as a theory of electric action it is a distinctly retrograde step on Maxwell's scientific position that he did not know what was the structure of the ether.

M. Poincaré proceeds to criticize Faraday's theory of the stresses in the dielectric, which he attributes to Maxwell. He begins by suggesting that the forces should have been explicable by the elasticity of the inductive fluid, in the same way as mechanical forces are due to the elasticity of matter. He has in this quite forgotten that what he calls the elasticity of this fluid, is not a bit like the elasticity of any matter, and would require either a second fluid, which he rejects, or some structure other than the fluid, to explain its properties. Granting such an additional structure, then the elastic energy of the medium, fluid and structure combined, *does* exactly explain the motions of conductors. Nobody has explained exactly *how* conductors differ from non-conducting space in structure, and can or do move, and this is not a bit clearer on Mossotti's hypothesis than on any other, not even when the non-conducting diaphragms are made infinitely thin. Maxwell long ago pointed out that no linear system of stress could leave a medium in equilibrium and move bodies immersed in it; and yet M. Poincaré criticizes Faraday's system because it is not linear; and this after remarking himself that the elasticity postulated already was not a bit like that of matter. All that is necessary is some assumption as to the connection between the conducting matter and the dielectric, for the "fluide inducteur" by hypothesis has elastic properties that make it the seat of the right amount of potential energy; and all that can possibly be necessary is to connect the matter with it in such a way that the energy of the medium lost when the conductor moves is given up to the conductor. M. Poincaré has again omitted to remember that the peculiar elasticity of the "fluide inducteur" necessitates some structure with which it is connected, and the Faraday stress may be in this structure, and due to its con-

nection with the "fluide inducteur," and not at all due to another fluid with peculiar properties. If the stresses are due to the connections of the "fluide inducteur" there is no great difficulty in supposing them proportional to the squares of the displacements of the "fluide inducteur," just as the increased tension of a stretched horizontal string due to a small weight at its centre is proportional to the square of this weight. In fact, a suggested model working upon this sort of principle has been published as illustrating this very point, and Dr. Lodge's model ethers, in the first part of his "Modern Views," are all of this kind.

M. Poincaré proceeds to find "une difficulté plus grave." He creates this by assuming that the energy of the medium is all due to the work done by these mechanical stresses deforming it. This is a most gratuitous assumption. Take the case of the stretched string with the weight on it. The increased energy of the system is not due only to the work done by the *increased* tension. At last he confesses, however, that if the energy in the dielectric be kinetic and not potential these difficulties would disappear. "Mais on ne peut encore adopter cette interprétation de la pensée de Maxwell sans se heurter à de grandes difficultés." And why? Merely because Maxwell afterwards calls the electric energy potential while he calls the magnetic energy kinetic. Has M. Poincaré forgotten that potential energy may in any case be the kinetic energy of an associated system? or can he not imagine two modes of motion of the same medium? Anyway, if the potential energy may be the kinetic energy of an associated system, and if M. Poincaré's difficulties are inapplicable to a kinetic explanation of the phenomena, it seems impossible but that they are really inapplicable to a potential system if this system be judiciously devised. It is just here that M. Poincaré fails. He revels in elastic fluids, and yet he continually harps upon the same difficulty—namely, "How can an incompressible liquid be elastic at all?"—and instead of once for all solving this by acknowledging that there must be some structure, he reverts to it as if it were a new difficulty whenever he comes across its consequences.

As a mere mathematical work the book is admirable and clear, if a little prolix. GEO. FRAS. FITZGERALD,  
Trinity College, Dublin, March 24.

#### Prof. Burnside's Paper on the Partition of Energy, R.S.E., July 1887.

In his criticism on a paper of mine on the partition of energy in a set of non-homogeneous spheres (NATURE, March 31, p. 512), Mr. Watson says that the conclusions are vitiated owing to my having omitted to introduce the frequency factor of collisions before proceeding to take the averages. This is not exactly accurate, since a frequency factor is introduced, viz. the relative speed of the centres of inertia of the impinging spheres parallel to the line of impact.

In the spring of 1888 Prof. Boltzmann published a criticism of the same paper in the *Sitzungsberichte* of the Vienna Academy, in which he contended that the correct frequency factor should be the relative speed of the points of impact of the spheres parallel to the line of impact; and in which he showed that the result of averaging with this frequency factor is to make the mean rotational energy equal to the mean energy of translation. Had I been entirely satisfied at the time of the cogency of Prof. Boltzmann's reasoning, I should, of course, have published a short note calling attention to the correction he proposed to make; and I regret now that this was not done, as it would have prevented the waste of a certain amount of valuable time and trouble.

W. BURNSIDE.  
Royal Naval College, Greenwich, April 1.

DR. WATSON has shown in his letter to NATURE of March 31 (p. 512) how the general methods of Maxwell and Boltzmann may be applied to the particular problem discussed by Prof. Burnside. He has also pointed out an error in Burnside's reasoning—namely, the non-introduction of the factor  $u - U + c\theta$ , whereby Burnside's conclusions at variance with the Maxwell-Boltzmann law of partition of energy are vitiated.

You may, perhaps, allow me space to point out a little more precisely in what, as appears to me, the error consists. Burnside has to find the average value of the expression—

$$(u - U + c\theta) \{2\theta - c(K + \lambda)(u - U)\}$$

(see p. 503). Now, we may take averages in two ways:

(1) as above noticed for all collisions by introducing the factor  $u - U + c\omega$  to denote frequency of collision; or (2) for all spheres as they exist at a given instant. Now, Prof. Burnside has calculated the average rotation energy by method (2), which gives  $2A\bar{\omega}^2 = \frac{1}{h}$ . But when he comes to

the translation energy, he takes the result  $(\bar{u - U})^2 = \frac{2}{h}$  from Prof. Tait, not observing, I think, that that result is given by Tait as the average for all collisions per unit time. And then, equating two inconsistent things, he gets the conclusion  $\frac{1}{h} = \frac{2}{h}$ , or the mean energy of rotation is twice that of translation.

To be consistent, he should have given the mean of  $(u - U)^2$  for all pairs of spheres—that is,  $\bar{u^2} + \bar{U^2} = \frac{1}{h}$ . And so his result should have been  $\frac{1}{h} = \frac{1}{h}$ , agreeing with Maxwell.

It may be interesting to see what would have been the result of introducing the factor  $u - U + c\omega$  to denote frequency of collision. The expression whose average is required would then be—

$$(u - U + c\omega)^2 (2\omega - c(K + k)(u - U)).$$

As the frequency factor  $u - U + c\omega$  must be always positive, we must integrate between the limits  $U = +\infty$  to  $U = -\infty$ , and  $u = +\infty$  to  $u = U - c\omega$ . After integration, we reject odd powers of  $\omega$ .

I have worked it out to the first power of  $\epsilon$ , rejecting  $\epsilon^2$ , &c. We have, in that case, to evaluate—

$$\int_{-\infty}^{\infty} \int_{U-c\omega}^{\infty} \{2\omega(u - U)^2 + 4c\omega^2(u - U) - c(K + k)(u - U)^2\} \epsilon^{-hU^2} \epsilon^{-hU^2} du dU.$$

The first term gives zero. The second term gives  $\frac{4c\omega^2}{h}$ , and the third term gives  $\frac{2c(K + k)}{h^2}$ . From which, on substitution,

and integrating for  $\omega$ ,  $\Omega$ , &c., from  $\infty$  to  $-\infty$ , we easily obtain  $k_1 = k_2 = \&c. = h$ .

To extend the process to cases in which  $\epsilon^2$ , &c., cannot be neglected, would be difficult. But I think the *onus probandi* now lies on the other side. S. H. BURBURY.

#### Double Orange.

On a blood orange being cut open by my little daughter yesterday, a small orange was found inside, which, although no larger than a hazel-nut, was yet perfect in form and colour. It showed no point of difference, other than that of size, as compared with the parent orange, and there was nothing in the appearance of the uncut fruit suggestive of the miniature of itself carried within. My sole right to write upon this subject is one you have always recognized in your journal, viz. that to record an interesting fact.

GERALD B. FRANCIS.

Katrine, Surbiton.

#### METALS AT HIGH TEMPERATURES.<sup>1</sup>

I PROPOSE this evening to consider, first, the methods of measuring high temperatures, and, second, to describe certain effects they produce on metals.

Geber, writing in the eighth century, gives directions for obtaining high temperatures, but points to the difficulties that arise in practice, "because fire is not a thing which can be measured, *sed quoniam non est res ignis, quæ mensurari possit.*"<sup>2</sup> It is not sufficient to attain

temperatures that are known to be high; it is necessary, for the purpose of modern investigation, to measure them with accuracy; and few of the early chemists in this country did more in affording a basis for the study of metals at high temperatures than Robert Boyle, the application of whose well-known law to solutions of metals in each other has been made evident by recent work. The 30th of December last was the third centenary of his death; it is well, therefore, that this lecture should begin with a tribute to his memory. He suggested improvements in the ordinary mercurial thermometer,<sup>3</sup> constructed what would appear to be the first air thermometer with an index; and although he did not do much for thermometry at high temperatures, he appears to have been struck by what must have been a quaint device for regulating high temperatures, for he points out that "the great mechanic, Cornelius Drebel<sup>4</sup> made an automatus musical instrument and a furnace which he could regulate to any degree of heat by means of the same instrument." He indicates various degrees of intensity of heat by reference to the colour of a glowing mass of fuel, and says that<sup>5</sup> "tho' we vulgarly say in English, 'a thing is red hot,' to express a superlative degree of heat, yet, at the forges and furnaces of artificers, by a white heat they understand a further degree of ignition than by a red one." It is not a little strange that for three centuries after his death the same vague expressions have constantly been used in describing high temperatures.

A great step in advance was made in 1701 by Sir Isaac Newton,<sup>4</sup> who applied the law of cooling to the measurement of temperatures beyond the range of the mercurial thermometer, and in the notes which accompany his "Scala graduum caloris" he showed that he knew that the freezing-point of lead differs slightly from its melting-point.

Eighty years later, Josiah Wedgwood (1782),<sup>5</sup> aided by one of my predecessors, Mr. Alchorne, Assay Master of the Mint, determined a few melting-points of metals, and, in communicating a description of his "thermometer for measuring the higher degrees of heat" to the Royal Society, we find him, one thousand years after Geber had said that "fire cannot be measured," still lamenting the want of suitable instruments, saying: "How much it is to be wished that the authors [to whom he refers] had been able to convey to us a measure of the heat made use of in their valuable processes; . . . a red heat, a bright red, and a white heat are," Wedgwood adds, "indeterminate expressions, and even though the three stages are sufficiently distinct from each other, they are of too great latitude, and pass into each other by numerous gradations which can neither be expressed in words nor discriminated by the eye." Another ninety years brings us to the last time that the measurements of high temperatures formed the subject of a Friday evening discourse in this Institution. On March 1, 1872, the late Sir William Siemens addressed you on the measurement of "heat by electricity,"<sup>6</sup> and, speaking of the mercurial thermometer, said: "When we ascend the scale of intensity we soon approach a point at which mercury boils, and from that point upwards we are left without a reliable guide, and the result is that we find, in scientific books on chemical processes, statements to the effect that such and such a reaction takes place at a 'dull red, such another at a 'bright red,' or a 'cherry red,' or a 'white heat'—expressions which remind one," he adds, "of the days of alchemy rather than of chemical science at the present day."

<sup>1</sup> Boyle's Works, Shaw's edition, vol. i. p. 575, 1778.

<sup>2</sup> Cornelius van Drebel, 1572-1634, *loc. cit.* vol. iii. p. 38, 1738.

<sup>3</sup> *Loc. cit.*, vol. ii. p. 28.

<sup>4</sup> Phil. Trans. Roy. Soc., vol. xxii. p. 824.

<sup>5</sup> *Ibid.* vol. lxxii. p. 305.

<sup>6</sup> Roy. Inst. Proc., vol. vi. p. 438, 1872.

<sup>1</sup> A Lecture delivered at the Royal Institution by Prof. W. C. Roberts-Austen, C.B., F.R.S., on Friday evening, February 5, 1892.

<sup>2</sup> From the edition of his "Summa Perfectionis Magisterii," p. 28, published in Venice, 1542.



It is not a little singular that the same lament should have been uttered, with so long an interval between, by two prominent technical men, and it suggests that but little experimental work had been done in the meantime with a view to the measurement of high temperatures. This is, however, far from being the case. A vast amount of work was done by physicists and metallurgists whose chief masters were "indefatigable labour, the closest inspection, and hands that were not afraid of the blackness of charcoal"; and their more noteworthy efforts were based on the employment of the air thermometer, in which the expansion of air replaces the expansion of the mercury in the ordinary thermometer, the bulb being of some fire-resisting material.<sup>1</sup> For this purpose, Princep (1827) used a bulb of gold, Pouillet (1836) one of platinum, and finally, Deville and Troost, in a truly splendid series of investigations, adopted bulbs of porcelain, with iodine vapour as the elastic fluid. They ultimately reverted to the use of air.

You will remember that old mercurial thermometers had much information, supposed to be useful, engraven on their scales, and such statements as "water freezes," "water boils," "blood heat," "fever heat," "summer heat," were considered indispensable. It is by exposure to known temperatures that a thermoscope can be converted into a pyrometer for measuring intense heat; and the air or gas thermometer has, in the hands of Deville and Troost, rendered excellent service by enabling such gradations to be effected. The gas thermometer is not, in itself, a handy appliance, for it requires much subsidiary apparatus, and elaborate corrections of various kinds have to be introduced into the numerical data it affords; but it has given many fixed temperatures—such as melting-points and boiling-points of elements, and of compounds—which may safely be made use of in graduating pyrometers. For very high temperatures, 900° C. and over, we rely on the excellent work of M. Violle<sup>2</sup> on the specific heats of platinum, silver, gold, palladium, and iridium, which have enabled the melting-points of the respective metals to be calculated.

The determinations of temperatures between 300° and 1000°, which are now generally accepted, also rest upon data accumulated by the aid of the air thermometer, which has thus enabled the graduation to be effected of instruments widely differing from it, that can be trusted to give rapid and accurate indications in daily use. I can only bring before you two of the many kinds which have been devised; they are, however, by far the best that are available, and for the determination of temperatures up to the melting-point of platinum, leave little to be desired—

(1) A pyrometer which depends on the increase in the resistance of a heated conductor through which a divided electrical current is passing; and

(2) One in which the strength of an electric current, generated by the heating of a thermo-junction, is used as a measure of the heat applied to the thermo-junction.

The principle of the electrical resistance pyrometer was indicated by Sir William Siemens ("Collected Papers," vol. ii. "Electricity," p. 84, 1889) in a letter addressed to Dr. Tyndall, dated December 1860, and the nature of the instrument may be made clear by the accompanying diagram, Fig. 1. A divided current passes from the battery B, to a platinum wire, C, coiled round a clay cylinder, and to a resistance coil, R. At the ordinary temperature the resistance of the platinum coil is balanced by the standard resistance R. If, however, the platinum coil be heated, its resistance will be increased, and, this increase of resistance, which can be measured in various ways, indicates the temperature of the coil C. The coil itself may be adequately protected and exposed to tem-

peratures which have been determined by the air thermometer; the deflection of a suitable (differential) galvanometer, G, will then indicate temperatures directly. For instance, the temperature at which zinc boils has been accurately fixed at 940° C., and if the coil is heated in the vapour of boiling zinc, the angle through which the galvanometer mirror is deflected marks the temperature of 940° C.

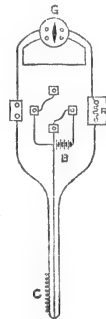

FIG. 1.

The Report of a British Association Committee showed in 1874 that the instrument is liable to changes of zero, but Mr. H. L. Callendar has recently (1887) restored confidence in the method which had been shaken by the Committee. He has proved that if sufficiently pure platinum wire be used, and if the wire be carefully annealed and protected from strain and contamination,<sup>1</sup> resistance pyrometers may be made practically free from changes of zero even when used at temperatures as high as 1000° C. He attributes the changes of zero to which the Siemens pyrometers are liable to the action on the wire of the clay cylinder on which it is wound, and of the iron tube in which it is inclosed. As the result of his experiments he has introduced certain modifications, which render the instrument not only trustworthy but very sensitive. He winds the platinum wire on a thin plate of mica, and incloses it in a doubly glazed tube of hard porcelain. He uses the zero method of measuring the resistance; but for these and other details of manipulation his own very interesting papers must be consulted. I will only add that I have had the pleasure of working with him in the Mint Laboratory, and I am satisfied that at temperatures above 1000° the comparative results afforded by his method are accurate to the tenth of a degree, a result which would certainly have been deemed impossible a year or two ago.<sup>2</sup>

The necessity for working with small volumes of fused metals, into which the tube of Callendar's pyrometer could not be plunged, has led me to prefer to adopt a method that would be classified under the second heading I have given. A very small thermo-junction may, in fact, be employed in such cases. The use of thermo-junctions for measuring high temperatures appears to have been sug-

<sup>1</sup> Phil. Trans. Roy. Soc. vol. 178 (1887), A, pp. 161-230, and vol. 182 (1891), A, pp. 119-157; Phil. Mag. vol. xxxii. July 1891, p. 104, and vol. xxxiii. Feb. 1892, p. 220.

<sup>2</sup> As this statement has been received with some surprise, it may be as well to state briefly how this degree of accuracy and sensitiveness is attained. The resistance-box is compensated for changes of temperature, and changes of resistance in the wires leading to the pyrometer are automatically eliminated. The resistance itself is measured by a modification of the well-known Carey-Foster method. The balancing resistance of the Wheatstone bridge employed, is composed partly of resistance coils and partly of a bridge wire along which a contact key slides. The resistance of a centimetre of this wire is made to correspond to the increase of resistance of the pyrometer produced by a rise of 1° C. The galvanometer can easily be made sensitive to one-hundredth of a centimetre of this bridge-wire, so that one-tenth of a centimetre, which corresponds to one-tenth of a degree, can, of course, be measured with certainty.

<sup>1</sup> See the excellent bibliography given by C. Barus, Bull. Geological Survey, U.S.A., No. 54, 1889.

<sup>2</sup> Comptes rendus, vol. lxxxix. p. 702, 1879; vol. xcii. p. 866, 1881.

gested in 1826 by Becquerel, and adopted by Pouillet in 1836,<sup>1</sup> who advocates the use of iron in conjunction with platinum; but of all the varied combinations of metals and alloys which have been tried from time to time, that proposed by H. Le Chatelier possesses many advantages, on which I have elsewhere dwelt.<sup>2</sup> It consists of a platinum wire twisted at its end with a wire of platinum alloyed with 10 per cent. of rhodium. Such a couple may be used for some time without change of zero, and if the junction becomes injured it may be cut off, and the severed ends of the wires may be twisted together again. I am satisfied that it can afford comparative results which are accurate to 1° at temperatures of over 1000°. The diagrams given later (Figs. 4, 5, and 6) show the disposition of the apparatus. The spot of light indicating the deflections of the galvanometer needle is caused, for the illustrations of this lecture, to fall onto a graduated scale 45 feet long on the wall of the theatre. The thermo-junction has been calibrated with the aid of certain known temperatures, and the long scale is inscribed after the manner of the old thermometer scales, with certain fixed points, which are, of course, far higher than those it was possible to indicate by the expansion of mercury in a glass tube. [These fixed points were: "water boils" (100°), "lead melts" (326°), "zinc boils" (940°), "gold melts" (1045°), "palladium melts" (1500°), "platinum melts" (1775°). On heating the thermo-junction to bright redness in a Bunsen flame, the spot of light moved rapidly to the point marked "zinc boils." For laboratory experiments the scale is a short transparent one, rigidly fixed in relation to the galvanometer.

In leading up to the experiments which follow, in the course of which metals will be exposed to high temperatures, I would remind you that if an ordinary thermometer be plunged into water which is gradually losing its heat to a cold environment, the mercury will fall until the water begins to freeze, but directly this happens the mercury remains stationary until all the water is frozen; so that if the rate of fall be measured with a chronograph, there will be a steady fall to the freezing-point of water, then a long arrest, followed by a renewed fall. If these readings be plotted, a well-known time-temperature curve will be obtained. Exactly the same effect is produced when a fluid metal "freezes," and before proceeding further it may be well to determine experimentally the freezing-point of gold. Beneath this little mass of pure gold, A (Fig. 2), a thermo-junction, B, is protected by a very thin

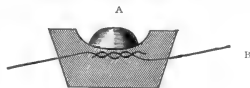

FIG. 2.

layer of clay from the metal. The oxyhydrogen flame is made to play on the gold, there is a rapid movement of the spot of light over almost 25 feet of the scale, there is a diminution in the rate of rise near the point marked 1045°, the melting-point of gold; and then, when the metal becomes fluid, the temperature rapidly rises as more heat is given to the little mass. The source of heat is now removed, the temperature falls, there is an arrest just at 1045° C., the freezing-point of gold, and then the spot of light resumes its course as the gold cools down to the temperature of the room. The melting-point and freezing-point of palladium, 1500° C., were then shown in the same way. It should be observed, however, that when a small fragment of palladium is fused in the naked flame of the oxyhydrogen blow-pipe, hydrogen appears to be ab-

sorbed by the metal; and this absorption of gas lowers the freezing-point materially, and makes it far less steady than when a fresh piece of metal, cut from a large mass, is fused for the first time.

When the spot of light is allowed to fall on a sensitized plate in a suitable camera,<sup>1</sup> the time-temperature curve traced on a moving plate will be of the form shown in Fig. 3.

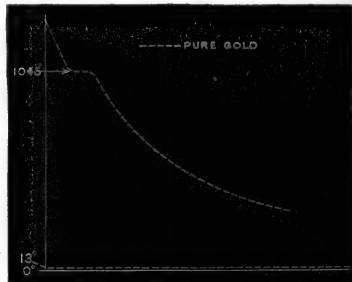

FIG. 3.

It may be useful to show the method by which these autographic curves are obtained: the following diagram, Fig. 4, is therefore added.

The arrangement consists in inclosing a galvanometer of the Deprez and d'Arsonval type in a large camera; a fixed mirror, F, being placed below the movable mirror, M, of the galvanometer, so that the light, from the lime cylinder L, reflected in the mirror H, passes to both mirrors, F and M, and is reflected in the direction of a fine horizontal slit, A B, behind which a sensitized photographic plate, C, is drawn vertically past the slit, by means of gearing, D, driven by clockwork. The ray from the fixed mirror is interrupted periodically by the vane E, and a beaded datum line is given, which enables any irregularity in the advance of the plate to be detected.

The amount of divergence from its datum line of the spot of light reflected by the movable mirror at any given moment bears a relation (which can readily be found by calibration) to the temperature to which the thermo-junction X is heated, and the variations of temperature are recorded by a curve which is the resultant of the upward movement of the plate and the horizontal movement of the spot of light. A crucible, C, which may be filled with molten metal, is provided with a tubulure, T, for the insertion of the thermo-junction. The crucible is suspended by wires in a double jacket of tin plate, a b.

It will have been evident that the thermo-junction of platinum and platinum-rhodium could not be used for measuring temperatures higher than the melting-point of the platinum of which it is made. Metals with higher fusion-points than platinum are, however, available; thus iridium will only just melt in the flame produced by the combustion of pure and dry hydrogen and oxygen. By the kindness of Mr. Edward Matthey, a thin rod of iridium has been prepared with much labour, and it can be used as a thermo-junction with a similar rod of iridium alloyed with 10 per cent. of platinum. The junction may be readily melted in the electric arc, and by this means a temperature may be registered which careful laboratory experiments show to be close to 2000°, and this agrees with the estimate of the melting-point of iridium which Violle<sup>2</sup> deduced from calorimetric experiments. [This experiment was shown, a different scale being employed for the screen, as the thermo-electric constants of the iridium, and iridium-platinum couple, are different from those of the platinum and rhodium one previously used.]

It is interesting to remember that within a year in this Institution temperatures ranging from -200° to +2000°

<sup>1</sup> *Comptes rendus*, vol. iii. p. 782, 1836

<sup>2</sup> British Association Lecture, *NATURE*, vol. xli., 1889, pp. 21-32; Report Inst. Mech. Eng., Oct. 1891, p. 543.

<sup>1</sup> Proc. Roy. Soc., vol. xlix., 1891, p. 347.

<sup>2</sup> *Loc. cit.*

have been mapped out, the lower temperature by Prof. Dewar in his memorable Faraday Lecture : the higher point is now measured in public for the first time.

How difficult it is for us to realize what this range of temperature really means, for we have but little power of appreciating temperatures beyond those we can conveniently bear. We, perhaps, know the meaning of extreme cold better than great heat, but even the vivid imagery of Dante, who might have been expected to afford some guidance, gives us singularly little help. I think in depicting the terror of torture inflicted by extreme cold he succeeds better than when he describes the suffering of those who are exposed to flames. His words (Canto xxxiii.)—

“Blue, pinched, and shrined in ice the spirits stood”—

mark the highest suffering drawn in the “Inferno.” It is, however, probable that my failure to appreciate the descriptive powers of Dante may be the result of resent-

ment, for I read with regret that he consigns to the tenth chasm of Hell, not only the coiner who  
 upon earth. We will not dwell in this lecture on the effects of very high temperatures on metals, but rather on the influence of comparatively low temperatures—that is, below whiteness—in changing the number and arrangement of the atoms in metallic molecules. A profound change must occur when the viscous form of sulphur passes spontaneously at the ordinary temperature into the yellow crystalline variety, but the change is accompanied by but little thermal disturbance. In the case of metals there is also abundant evidence that molecular change may take place at low temperatures. Take the fusible alloy of bismuth, lead, and tin, which bears Newton's name, and contains—

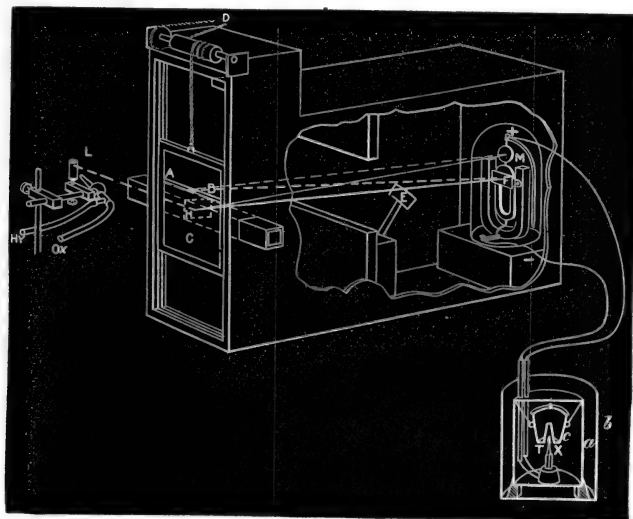

FIG. 4.

ment, for I read with regret that he consigns to the tenth chasm of Hell, not only the coiner who

“falsified  
 The metal with the Baptist's form impressed,”<sup>1</sup>  
 but also an honest metallurgist, Cappoccio of Sienna, who,  
 “by the power  
 Of alchemy, . . . aped creative Nature by his subtle art” ;  
 and, I think, deserved a better fate.

We are now in a position to consider certain other effects of high temperature on metals. Many years ago, my colleague Mr. Lockyer, and I, conducted an investigation on the spectra of the vapours of certain metals<sup>2</sup> at the highest temperatures we could produce, with the aid of the oxyhydrogen flame. We distilled silver, zinc, cadmium, and volatilized iron and other metals, from a lime crucible, and caused their vapours to pass into a horizontal tube of strongly-heated lime. By these experiments we satisfied ourselves that the molecular structure of metals is gradually simplified as higher temperatures are employed ; and

upon earth. We will not dwell in this lecture on the effects of very high temperatures on metals, but rather on the influence of comparatively low temperatures—that is, below whiteness—in changing the number and arrangement of the atoms in metallic molecules. A profound change must occur when the viscous form of sulphur passes spontaneously at the ordinary temperature into the yellow crystalline variety, but the change is accompanied by but little thermal disturbance. In the case of metals there is also abundant evidence that molecular change may take place at low temperatures. Take the fusible alloy of bismuth, lead, and tin, which bears Newton's name, and contains—

Bismuth	...	...	...	50°00
Lead	...	...	...	31°25
Tin	...	...	...	18°75

100°00

It fuses at 90° ; it may be cast round a thermo-  
 junction, and plunged in water and cooled thoroughly until the observer is certain that the mass has returned to the atmospheric temperature : take it out of the water, dry it

<sup>1</sup> The golden florin of Florence.  
<sup>2</sup> Proc. Roy. Soc., vol. xxiii. p. 344; 1875.

rapidly, and in a few moments it will become too hot to hold. The "fracture" of the metal is totally different before and after the molecular change, which is the cause of this evolution of heat, has taken place. The change, moreover, takes place in the solid metal, and is not due to the release of the latent heat of fusion. The mass, solid as it appears to be, must be the scene of an internal struggle between the molecules in the effort to attain a state of equilibrium, and this conflict is but a type of the action that takes place in many metals and alloys which are of vast industrial importance.

Time will only permit me to deal with three cases of the action of high temperatures on atoms and molecules of metals. In the first case, the *arrangement* of the atoms in the molecule of a metal, iron, is disturbed, and the result is of great industrial importance. In the second case, the atoms of a metal, gold, appear to *combine* with those of another metal; and the result, while it is mainly of interest in connection with the history of science, has nevertheless an important bearing upon art. The third case relates to the *molecular bombardment* which takes place when a small quantity of metal is dissolved in a mass of a metallic solvent, and is of interest in connection with modern views both as to osmotic pressure and solution generally.

(1) The pyrometric couple is inserted in the centre of a little mass of steel, which is being slowly raised to a bright red heat; when the flame is withdrawn, the spot of light will return towards the zero end of the scale, falling slowly until a temperature of  $655^{\circ}$  is reached, and then there will be an abrupt and prolonged arrest. The metal has never been near its melting-point, and the evolution of heat must be due to a molecular change in the solid metal. In the case of this particular sample of steel, the evolution of heat is mainly the result of a change in the relation between the carbon and the iron; but by laboratory experiments and careful chronographic records, Osmond has shown that, in the case of certain varieties of steel, it can be demonstrated that what here appears as a single change, attended by an evolution of heat, is really an exceedingly complex one. I have shown that it occurs in the purest iron the chemists can prepare by electrolysis, and I agree with Osmond in believing that the change which occurs in pure iron at  $835^{\circ}$  is a molecular one, independent of the presence of impurity. If the mass of steel (Fig. 5, *a*) be heated again and allowed to

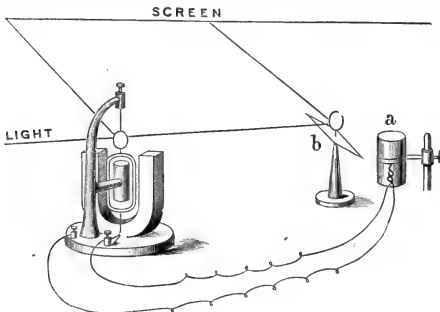

FIG. 5.

cool, you will observe that the point of "recalcescence" appears to be that at which the iron regains its magnetic property; <sup>1</sup> for a magnetized needle, *b*, is attracted at the

<sup>1</sup> The temperature at which these molecular changes take place in iron and steel was first demonstrated to an audience in my Newcastle lecture, 1889; but my friend Prof. Reibold, of the Royal Naval College, first arranged an experiment for lecture purposes which showed the magnetic change simultaneously with the thermal one.

moment the arrest of the spot of light on the pyrometer scale marks the temperature at which the change occurs, and at that precise moment a second spot of light from a mirror, mounted on the magnetic needle, will rapidly move away from its zero. I have elsewhere <sup>1</sup> dwelt on the importance of the molecular change in iron and steel, and can now only summarize the significant facts.

It is unnecessary to point to the extreme industrial importance of the property steel possesses, of becoming hard when it is quenched from redness in a fluid which will abstract its heat with more or less rapidity.

The changes which take place at  $835^{\circ}$  and  $650^{\circ}$  have to be arrested, as it were, by rapidly cooling the mass of steel; and if this is done, the steel will be more or less hard according to the rapidity with which the progress of the molecular change has been stopped. It is, however, useless to attempt to harden steel if the temperature of the mass has fallen below  $650^{\circ}$ . In "oil hardening" or cooling a large mass of steel, like the "A" tube of a gun, which may be 30 feet long, great care should be taken to insure that the temperature of the mass is as uniform as possible; for, if part of the mass is hotter than  $650^{\circ}$ , while part is colder, the oil will really be cooling a mass of steel which is itself passing through various stages of complex molecular change, and the operation of "hardening" arrests, as it were, the atoms in the midst of a conflict incidental to their attempt to group themselves into one or other of the molecular modifications of iron. By cooling a mass of steel which is not at uniform temperature, stresses of great complexity and intensity are set up, stresses that may greatly reduce the effective strength of the gun. <sup>2</sup> The result is told in failures, by which many lives have been sacrificed; but I need hardly say that the Director-General of Ordnance is fully sensible of the national importance of studying the behaviour of iron and steel at high temperatures, and, at Dr. Anderson's suggestion, the Institution of Mechanical Engineers appointed a Committee, and have intrusted me with a large portion of the inquiry.

In the next experiment, Fig. 6, a bar (*a*) of steel,  $\frac{1}{2}$  inch

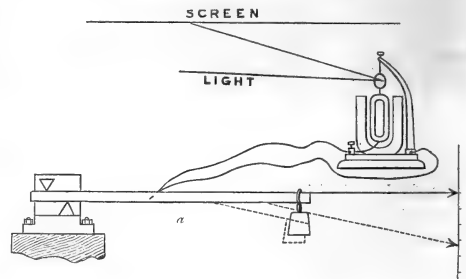

FIG. 6.

in section and 18 inches long, was heated to bright redness and fixed firmly at one end; a weight of about 2 pounds is rapidly hung to the free end, a light pointer is added to magnify the motion of the bar, and the thermo-junction is rapidly introduced into a small hole drilled in what is arranged to be the hottest part of the bar. The bar is not softest at a red heat; it remains perfectly rigid until it has cooled down to dull redness, and the temperature, as measured by the spot of light from the galvanometer, shows that "recalcescence" has occurred. At that mo-

<sup>1</sup> Report to the Institution of Mechanical Engineers, Proceedings, 1891, p. 543.

<sup>2</sup> "Internal Stresses in Cast Iron and Steel," by Nicholas Kalakoutsky, 1888.

ment of molecular weakness in the bar, the weight has power to bend it, and the pointer falls. By such experiments the exact temperature at which the metal becomes weak, in different varieties of steel, can readily be determined.

(2) Evidence will now be given in support of the second case it was proposed to treat, and it will be shown that at high temperatures the atoms of metals may truly combine with each other; in fact, taking gold as a basis for the experiments, compounds may be formed which would, had they been known centuries ago, have strangely affected the history of science. When the alchemists subjected the metals to high temperatures, their efforts were mainly directed to the discovery of some substance that would either change base metals to the colour of gold, or would give them the brilliancy of silver. The mediæval chemists believed that there were two distinct substances that would effect this, "one for the white" and another "for the red." Many of their writings might be quoted in support of this view, but a reference to Geber, who wrote in the eighth century, will be sufficient. He pointed out that the transmuting agent "has a tincture of

and stream of opal," reminding us of the crimson and purple of the poppy, the scarlet and orange of fire and the dawn. No wonder he chides us with turning the lamp of Athena into the safety-lamp of the miner, and with getting our purple from coal instead of, as of old, from the murex of the sea; "and thus grotesquely," he says, "we have had forced on us the doubt that held the old world between blackness and fire, and have completed the shadow and the fear of it by giving to a degraded form of modern purple a name from battle—'Magenta.'"

You will remember that Faraday showed that gold, when finely divided, is brilliantly coloured scarlet and purple. Here is a solution of chloride of gold. Add a little dissolved phosphorus, and the gold is precipitated in an extremely fine state of division, which tinges the solution crimson, but if you try to remove this suspended gold you will only gain a brownish mud. However, I will give you the secret by which anyone who possesses a blow-pipe, a bead of gold, and a fragment of one of the most widely-diffused metals, aluminium, may stain gold purple through and through. But if you add aluminium to molten gold, you

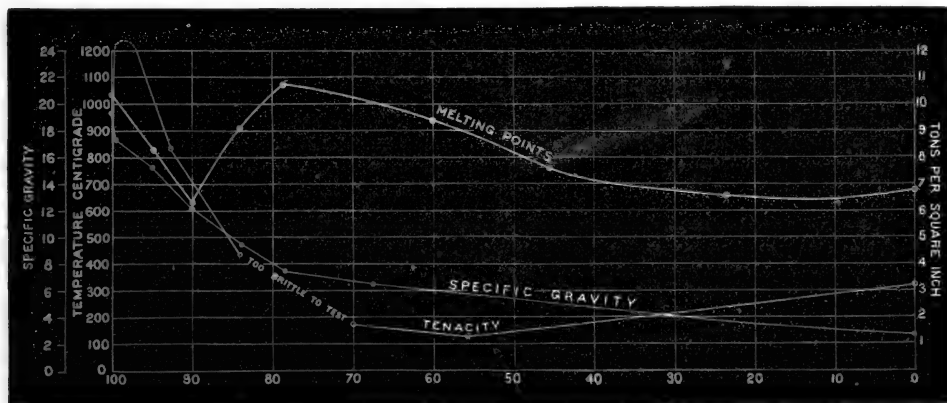

Fig. 7.

itself so clear and splendid, white or red, clean and incombustible, stable and fixed, that fire cannot prevail against it; . . . and a property of the medicine is to give a splendid colour, white or intensely citrine," to metals to which it is added.

That was the effect expected from the transmuting agent, but do not think that the attempt to produce gold arose entirely from the love of gain. The colour of gold and purple impressed men strangely, and the search for the transmuting agent was most eagerly pursued in times when people lived for art, in a dream of colour. The effort to find the secret of the tint of gold is due to the same impulse which made the French in the thirteenth century manifest a keen "sensitiveness to luminous splendour and intensity of hue," so that, as Sir Frederic Leighton tells us, "a stained glass window, by Cousin, was limpid with hues of amethyst, sapphire, and topaz, and fair as a May morning." The chemists were able to stain glass ruby and purple with gold: why should they not impart the same glories to metals? I could not hope to interest you in what follows, did I not call artists to my aid; and many will remember the glowing words Mr. Ruskin uses,<sup>1</sup> calling purple a "liquid prism

obtain many things, as this coloured diagram and series of specimens show. [This diagram cannot be reproduced without colour.]

The series of specimens showed that as the proportion of aluminium is increased, the golden colour of the precious metal is lessened, and when an alloy is formed with about ten per cent. of aluminium, the fractured surface of the mass is brilliantly white; from this point forwards, as aluminium is added, the tint deepens, until flecks of pink appear, and when seventy-eight parts of gold are added to twenty-two of aluminium a splendid purple is obtained, in which intense ruby-coloured opaque crystals may readily be recognized. Then, as the quantity of aluminium is still further increased, the alloys lose their colour, and pass to the dull grey hue of aluminium itself. Perhaps the most remarkable point about the purple alloy is its melting-point, which I have shown to be many degrees higher than that of gold itself.<sup>2</sup> See diagram, Fig. 7, in which curves of several constants of these alloys are given. This fact affords strong evidence that the alloy  $AuAl_2$  is a true compound, having analogies to the sulphides, for in every other series of alloys the melting-points of all the members of the series are

<sup>1</sup> "The Queen of the Air," ed. 1887, p. 129; *Times*, December 11, 1891.

<sup>2</sup> *Proc. Roy. Soc.*, vol. I, 1891, p. 367.

lower than that of the least fusible constituent. There is one other fact of much interest connected with this alloy. When it is treated with dilute hydrochloric acid, chloride of aluminium is formed, and gold is released in a singularly voluminous form. The heat of formation of the gold-aluminium alloy has not been determined, but hydrochloric acid, which will not attack gold, will readily split up this compound, of which more than three-fourths is gold; the compound, in fact, behaves like a distinct metal, having special heats of oxidation and chlorination of its own.

(3) Lastly, we come to the question of solutions of metals in each other. One very remarkable instance of the behaviour of metals at high temperatures reveals the fact that the presence of a small amount of a metal in a mass of another lowers the freezing-point of the mass. In the industrial world this has long been known. Cellini tells us, for instance, that when the bronze for his great figure of Perseus, at Florence, was running out of the furnace, it suddenly showed signs of setting, and he therefore threw pewter plates and dishes into the ducts through which the metal had to pass—"a thing," he says, "never before done." The fluidity of the metal was immediately increased, and he found every part of the casting "to turn out to admiration."

The excellent work of Heycock and Neville,<sup>1</sup> on the lowering of the freezing-points of metals, by the addition of other metals, should, I would suggest, form the subject of a lecture in this Institution at an early day. I cannot attempt to deal with the matter here. In leading up to these questions of solution, as applied to metals, I would remind you that Lord Rayleigh told us a few evenings since that it was by no means certain that a gas rushing into a vacuum globe ever completely fills it, as there may still be tiny spaces into which "odd molecules" fail to find room to vibrate in. If it is difficult for a gas to entirely fill a vacuum space, you would think it impossible for a small quantity of a metal to rapidly permeate a fluid mass of another metal; nevertheless, so far as analysis can detect, this does happen.

It may be incidentally observed that the relations of the ordinary gases to metals are far more intimate than they were formerly supposed to be, and this was proved by Graham's work on the absorption of gases by metals, which has often been dealt with in this Institution. To take only the case of iron, more than twenty years ago Sir Lowthian Bell showed that carbonic oxide can carry away iron, which is released when the temperature is raised. Ludwig Mond and Langer have since isolated most interesting compounds of iron and carbonic oxide. But to return to the solution of metals in metals.

The method of taking autographic curves of the cooling of masses of metal has already been indicated in Fig. 4,<sup>2</sup> and they ought to enable much information to be gained as to what is taking place throughout the mass. Such curves should render it possible to ascertain which of the rival theories as to the nature of solution, as applied to salts, is supported by the behaviour of a metal dissolved in a metal. When, for instance, a little aluminium dissolves in gold, is the analogue of a hydride formed, and, if so, is the curve of freezing-points of a series of aluminium-gold alloys a continuous one? On the other hand, does the theory advocated by van 't Hoff, Arrhenius, and Ostwald gain support, and do the molecules of the dissolved metals act independently of the solvent—that is, does osmotic pressure come into play? It will be remembered that the law which regulates osmotic pressure has exactly the same form as Boyle's law—that is, the pressure is

proportional to the density of the gas or of the solution. Is the view of Arrhenius correct—that, if a solution be very dilute, the molecules of the dissolved substance are dissociated, act independently of each other, and behave like a perfect gas?

It will require years of patient work before these questions can be answered; but it appears certain, from the admirable experiments of Heycock and Neville,<sup>1</sup> to which reference has already been made, that, taking metals with low melting-points (such as tin or lead) as solvents, the lowering of the freezing-point of the solvent is really due to the bombardment exerted by the molecules of the dissolved metals.

I have extended this investigation by employing as a solvent a mass of fluid gold, which has a high melting-point, and is not liable to oxidation, and the results conform those obtained by Heycock and Neville.

There is yet one other question: When metals are added in small quantities to a metallic mass, may the solvent remain inert? Here is a mass of 1000 grammes of lead, and to it 15 grammes of gold, or 1.6 atoms for every 100 atoms of lead, will now be added. It could be shown that the gold is readily dissolved, and remains dissolved, even if the lead be solidified. Now, to the fluid lead sufficient aluminium will be added to form the purple alloy with the dissolved gold; the mass will be well stirred, but the aluminium will not unite with the lead; it will nevertheless find out the gold, and, after uniting with it, will carry it to the surface of the bath. Thence it can be removed, and the purple colour of the alloy identified, or the gold it contains can be revealed by the method Prof. Hartley<sup>3</sup> has given us for detecting the presence of gold in an alloy by volatilizing the alloy in a torrent of sparks from an induction coil, and condensing the vapour on mica.

The union of the aluminium and the gold must, however, be peculiar. Crookes<sup>3</sup> has shown that when this alloy is used as an electrode in a vacuum tube, the gold is volatilized from the alloy and deposited as a film on the glass, leaving the aluminium behind.

The purple alloy presents us with the most interesting case yet known of a molecule built up of purely metallic atoms, but we are certain that the atoms are still those of gold and aluminium—that is, the atoms of the united metals remain unchanged. The interest in this substance is deepened if it be remembered that our aim at the present day is the same as that of the alchemists, for we are striving, as they did, to attack and change the chemist's atoms themselves. We seek, as truly as they, to effect the transmutations, which, as Boyle said, would "be none the less real for not being gainful," and employ high temperatures in the hope of simplifying the molecular structure of metals. We no longer consider gold to be the "sum of perfection," but still retain the belief expressed by Geber, eleven hundred years ago, that, "if we would change metals, we must needs use excess of heat." A poet also appears to have felt this, for George Herbert writes in the seventeenth century—

"I know . . . what the stars conspire,  
What willing Nature speaks, what forced by fire";

thus comparing the ordinary response of Nature to the investigator with the evidence he elicits from her by heat.

By fusing gold, and staining it "the purple of the dawn," a new interest has been given to the metal which the alchemists always connected with the sun; and for further proof that metallic atoms may be changed, we must turn to the sun itself, as to a great metallurgical centre, where "all the elements shall melt with fervent heat."

<sup>1</sup> Chem. Soc. Journ., vol. Iv., 1889, p. 666; vol. lviii., 1890, pp. 376, 656; vol. lix., 1891, p. 956.

<sup>2</sup> Proc. Roy. Soc., vol. xlix. p. 347, 1891.

<sup>3</sup> Loc. cit.

<sup>2</sup> Proc. Roy. Soc., vol. xlvi., 1889, p. 88.

<sup>3</sup> Proc. Roy. Soc., vol. i., 1891, p. 88.

ON INSECT COLOURS.<sup>1</sup>

## II.

NOW it is necessary to explain the "reversion effects" of red, so frequently alluded to. I am tempted to give a detailed account of the experiments made in this connection, but the length to which this article has already run warns me that I must be very brief indeed; and I will therefore content myself with giving simply the broad results.<sup>2</sup> All reds and pinks (always omitting the last four in the table), are turned orange or yellow instantly by acids. When nitric acid is used, this effect is *permanent*; and whether the yellowed wing be dried, or washed, the yellow is immovable. I have kept such wings for five or six months, and they were as yellow as possible at the end of that time. In the case of all other acids,<sup>3</sup> the yellow is *permanent only so long as the wing is actually acid*: directly the acid is removed, the original red returns; and thus a wing may be alternately yellowed and "reverted" time after time. This reversion to the original red may be produced either by long exposure to the air, allowing the last traces of acid to drain off; or instantly by neutralizing the residual acid with a drop of ammonia, or by copious washing. It must therefore be understood that, with the exception of those cases in which nitric acid has been used, the permanency of the artificial yellow is *entirely dependent upon the presence of acid*: remove the acid, and the yellow vanishes. Accordingly, I have suggested the following explanation. Let us denote the molecule of red pigment by X; when any acid, except nitric, is added, I assume that this forms with X a so-called molecular compound: for instance, on treating with hydrochloric acid, we should get the hydrochloride of X, viz. X.(H.Cl)<sub>n</sub>; and it is evident that these hydrochlorides, hydrosulphates, &c., of X are yellow, although the original X is red. To all these facts, of course, there are ample analogies known to chemistry. Next, for the resuscitation of red. We must suppose—what is certainly to all appearance very clear—that these molecular compounds are very unstable; an easily understandable fact; and that consequently the addition of even excess of water is sufficient to decompose them, removing the acid molecule, and thus restoring the pigment X to its original condition. Far more rapidly does this resuscitation occur if a drop of ammonia be used, this at once combining with the acid and liberating the X molecule. In the case of resuscitation produced by slow air drying, the action apparently would be in some cases due to gradual evaporation, or to some process of oxidation—anyhow producing dissociation of the molecular salt of X. Finally, in the case of nitric acid, it is clear that this acid does not form a molecular compound, but, as we might expect, exercises a permanently destructive action on the original pigment. Admitting that red has been developed from yellow, it is not surprising that it may be easily reconverted permanently into yellow by such a reagent as nitric acid. Before quitting this topic, I may point out that the cyanide reaction of the yellows is very suggestive indeed as to the kind of process by which the red pigment is developed from yellow.

Now, as to the last four species noted in the table. In these, I believe, the red is not developed from yellow at all, but from its close analogue, chestnut. Up till very recently, I supposed *V. atalanta* to be the only representative of such development, and was rather surprised that yellow should so commonly develop into red, and chestnut so rarely. But recently I have found that *Anartia amalthæa* is exactly identical in behaviour with *V. atalanta*, whilst *Heliconius amaryllis* seems half-way between these spe-

cies and the normal reds, but nearer to the former. The evidence on which this conclusion as to the nature of the red in *V. atalanta* was founded is as follows. The red of *atalanta* does not change to yellow, but to the brown or chestnut normally present in *V. cardui*, or to a more colourless tint. The change is not similar to that of red to yellow, but is a solution effect: consequently no reversion effect can be obtained; and this alone is almost decisive. It seems to me especially interesting that this experimental conclusion as to the nature of *atalanta* red is entirely corroborated by totally independent evidence from the entomological side, since the connection of *V. atalanta* and *cardui* is exceedingly close, and there are transition forms between them.<sup>1</sup>

And now we come to the last colour—chestnut—for which a very brief account will suffice, in addition to the details already given in the table, and the incidental remarks made during the discussion of yellow. It must be understood, then, that the constitution of chestnut appears to be very close indeed to that of yellow: like as in yellow, we can distinguish several stages of solubility, although deepening colour still less implies decreasing solubility even than it does in yellow—a conclusion which will be borne out by an examination of the table. Like yellow, chestnut may develop into red, as has already been explained; and the brilliant copper colour of *Lycæna phlæas* and *virgaurea* appears to occupy, both in its extreme solubility and its relation to the main line of development of the chestnut pigment, a position exactly analogous to that occupied by the orange of *E. cardamines* among the yellows. The only further remark that I have to make with reference to this colour concerns *V. io* and *V. antiopa*, which I have specially marked as notable examples.

In these species the rich chocolate colour is very soluble, but leaves a black wing instead of a white. If chestnut had been developed from a white pigment, this would have been a grave difficulty; but it perfectly accords with the view that the pigment has been developed, not from any such white pigment, but in a previously unpigmented, usually white, wing; in these species it has been developed in a previously black wing. I have always considered the behaviour of these two species to considerably support my views of the nature of the chestnut pigment, and indirectly of the yellow.<sup>2</sup>

The main heads of the preceding pages may be very briefly summarized as follows. Blacks and whites are not pigment but absorption and reflection colours respectively. The great majority of blues are also physical colours—chiefly, if not entirely, interference colours; and it is doubtful if there be any pigment blues at all. Some greens are also physical colours, very similar to the blues; the character of another group is somewhat ambiguous, although probably these, too, are physical. A third group, is pigmental, and probably derived from yellow. All reds are pigmental, being developed chiefly from yellow, but in a few cases from chestnut; the former are characterized by the reversion effect. The great majority of yellows are pigmental, of various degrees of solubility or insolubility; but a few cannot at present be decisively pronounced either physical or pigmental, and the same remark applies to the chestnuts.<sup>3</sup>

In concluding this summary of my work, I must point out that it is not put forward as in any sense of the word final, even so far as it goes, but merely as a basis of systematic inquiry, in various directions. Up to the present, almost nothing at all has been known about the behaviour or character of these colours; now I will dare

<sup>1</sup> There is similar evidence in the case of *Anartia amalthæa*. Two specimens of this were sent me for experiment. One was marked with a chestnut band, and one with a scarlet. This scarlet was at once changed into the chestnut normally present in the other.

<sup>2</sup> I am disappointed at having as yet come across no yellow species analogous to *V. io*. But in this connection I may call attention to the behaviour of the green species of *Cidaria*, which are changed to a brownish-grey. It is possible that these greens may be descended from yellow developed on an originally dark wing.

<sup>3</sup> Cp. the instances of *Vanessa io* and *antiopa*.

<sup>1</sup> Continued from p. 517.

<sup>2</sup> A full account of these experiments will be found in the *Entomologist*, xliii. pp. 39-40 and 53-59.

<sup>3</sup> I have used hydrochloric, sulphuric, acetic, phosphoric, hydrofluosilicic, and oxalic acids, in these experiments.

to hope that at least a basis of operations has been found. May I also venture to ask that any other investigators who may not have already been working on this subject will do me the favour of allowing me for a time to continue my researches alone—so far, that is, as concerns the Lepidoptera, both *imagines* and larvæ—for I

am planning various lines of research suggested by my previous work. As to the various other orders of insects, I shall be delighted if other workers who may have opportunities, that I have not, of obtaining abundant material, will take up the work, and determine how far my conclusions will hold for these other orders also.

TABLES OF RESULTS.<sup>1</sup>

Initial of group.	Name of species.	Natural colour.	Effect of reagents.	Initial of group.	Name of species.	Natural colour.	Effect of reagents.
R.	<i>Apatura iris</i>		Chiefly unaltered; gloss destroyed by KHO. The glow much dulled.	R.	<i>Papilio machaon</i>	Palish yellow	White.
"	<i>Trepachrois lineae</i>	Rich purple velvet glow		"	<i>Heliconius amaryllis</i>	Very pale yellow	Do.
"	<i>Hypolimnas bolina</i>		The glow much dulled or unaltered.	"	<i>Catopsilia catilla</i>	Light sulphur	Do.
"	<i>Hypolimnas salamis</i>	Violet	Dull steel blue.	"	<i>Vanessa antiopa</i>	Dull palish yellow	Whitish.
"	<i>Papilio</i> —six species	Bright and pale blues.	Bronze; leaf brown; or steel blue; &c.	"	<i>Charaxes athamas</i>	Light sulphur	White or towards whitish.
"	<i>Morpho menelaus</i>	Brilliant blue	Less brilliant.	"	<i>Tevnia nise and vabella</i>	No † Lemon yellow	Pure white.
"	<i>Papilio machaon</i>	Dullish blue	Greyish.	"	<i>Delias eucharis and hierle</i>	Yellow	Do.
"	<i>Limnitis sibylla</i>	Do.	Do.	"	<i>Hebomoia glaucippe</i>	Deep orange	Perfectly transparent.
S.	<i>Smerinthus ocellatus</i>	Do.	Greyish or unaltered.	"	<i>Colias satius</i>	Rich yellow †	Pure white.
N.	<i>Catocala frazzini</i>	Dull blue	No marked alteration.	"	<i>Gonepteryx cleopatra</i>	Bright brimstone	Practically white.
R.	<i>Vanessa</i> —four species	Blue	Paler or unaltered; destroyed in <i>V. antiopa</i> .	E.	<i>Hasis</i> sp.	Deep yellow	Unaffected or nearly white.
"	<i>Lycaena</i> —five species	Vari. us blues	Usually slate colour; occasionally greenish.	R.	<i>Euchloe cardamines</i>	Rich orange	White.
R.	<i>Parthenos gambrius</i> (upper surface)	Metallic green	Purplish bronze or blackish.	"	<i>Gonepteryx cleopatra</i>	Do.	Through brimstone to white.
"	<i>Hesperia</i> sp.	Dark metallic green	Do.	"	<i>Gonepteryx rhamnifera</i>	Bright brimstone †	Towards whitish.
E.	<i>Urania fulgens</i>	Do.	Do.	"	<i>Colias hyale</i>	Pale brimstone †	Lighter or fairly white. †
R.	<i>Papilio polytor</i>	Bronze yellow green	Brownish or blackish.	"	<i>Polymnatus alexis</i>	Orange	(Scarcely affected or towards whitish.
"	<i>Parthenos gambrius</i> (below)	Sage green	Dun brown.	B.	<i>Heplialus humuli</i>	Dullish yellow	Sickly yellowish; nearly transparent.
"	<i>Limnitis procris</i>	Do.	Dun grey.	G.	<i>Rumia crataegata</i>	Pale brimstone	Towards whitish.
S.	<i>Ino statice</i> , &c.	Glittering green	Bronze brown.	"	<i>Campylogramma bilineata</i>	Dull orange	Towards or whitish.
R.	<i>Argynnis paphia</i> , &c.	Deep foliage-green	Do.	"	<i>Hyria aurovaria</i>	No † Dull yellow	Whitish or white.
"	<i>Thecla rubi</i>	Almost arsenic green	Brown, like upper surface.	"	<i>Abraaxas grossulariata</i>	Palish orange	Towards white or white.
"	<i>Papilio</i> —four species	Leaf green	(Whitish; white; or yellow.	"	<i>Venilia maculata</i>	Yellow	(Unaffected, or paler; or white.
"	<i>Eromia argia</i>	Very pale greenish	Paler or whitish.	"	<i>Angerona prunaria</i>	Brownish orange	Dulled or unaffected.
N.	<i>Halias prasiana</i>	Green	Whitish; ochre yellow in one case.	R.	<i>Papilio asterias</i>	Orange yellow	Usually unaltered.
"	<i>M. orion</i> ; and <i>D. aprilia</i>	Do.	White.	"	<i>Ornithoptera darwins</i>	Crocus gold	Practically unaltered; but some probably dissolved.
G.	<i>Larentia</i> , &c.—several species	Do.	White; occasionally yellowish white.	N.	<i>Eudryas graia</i>	Yellow	Transparent or rather faded.
"	<i>Cidaria miata</i> , &c.	Do.	Brownish grey.	B.	<i>Tithonea hamoni</i>	Do. No †	Much paler, or towards whitish.
T.	<i>Tortrix viridana</i>	Do.	Whitish.				
R.	<i>Euchloe cardamines</i>	Pseudo-green	Black.				
S.	<i>Smerinthus</i> , &c.—several species	Pink *	Yellow or yellowish.				
B.	<i>Deiopeia bella</i>	Yellow.	Yellow.				
"	<i>Actias luna</i>	Do. *	Do.				
"	<i>Actias Cynthia</i>	Do.	Colourless or faded.				
"	<i>Heplialus humuli</i>	Do.	Faint orange.				
G.	<i>Hyria aurovaria</i>	Do.	Yellowish or whitish.				
"	<i>Aristelia rubricata</i>	Do.	Dunish colour.				
K.	<i>Parnassius apollo</i>	Red *	Orange.				
"	<i>Delias hierle</i> and <i>eucharis</i>	Red (*)	Yellow: then white.				
"	<i>Papilio</i> —various species	Crimson, scarlet, &c. *	Yellow, orange, &c.				
S.	<i>Zygæna filipendule</i>	Red *	Orange.				
B.	<i>Arctia caia</i>	Do. *	Do.				
"	<i>Euchelia jacobæ</i>	Do. *	Do.				
N.	<i>Catocala nupti</i>	Do. *	Do.				
"	<i>Xanthia silago</i>	Reddish	Yellow.				
K.	<i>Papilio vertumnus</i> and <i>constolchia</i>	Pale red *	(Pale ochrish or bread colour.				
"	<i>Heliconius amaryllis</i>	Scarlet	Brown: finally white.				
"	<i>Anartia amathea</i>	Do.	Chestnut.				
"	<i>Vanessa atalanta</i>	Do.	A. "cardus" brown.				

The following yellow or orange-yellow species are almost or entirely unaffected—  
(R.) *Papilio thoas*, *polyxenes*, and *philetor*; (B.) *Deiopeia bella*, *Callimorpha hera* (no †), *Arctia villica*, *Cithærona regalia*; (N.) *Xanthia silago*, *Triphena pronuba* (no †), *Helica tenebrata*.

R.	<i>Vanessa io</i> and <i>antiopa</i>	Chocolate	Blackish. N. B.
"	<i>V. urtica</i>	Rich chestnut	Whitish.
"	<i>Argynnis paphia</i> and <i>selene</i>	Rich chestnut	(Whitish; faded; or nothing.
"	<i>Danaus chrysippus</i> and <i>hegesippus</i>	Do.	Very faded; or whitish grey.
"	<i>Athyna neta</i>	Dull chestnut	White or transparent.
"	<i>Cæronympha pamphila</i>	Pale chestnut	Whitish or white.
"	<i>Hesperia sylvæus</i>	Chestnut	Faded or white.
"	<i>Lycaena phœas</i> and <i>argyrota</i>	Chestnut	Much faded or whitish.
"	<i>Vanessa cardui</i>	Chestnut	Faded or whitish.
"	<i>Epinephile tithonus</i> and <i>janira</i>	Do.	Faded more or less.
"	<i>Satyrus megara</i>	Yellow chestnut	Little faded only.
"	<i>Atella phalantia</i>	Rich chestnut	Faded or very faded indeed.
"	Rich chestnut	Rich chestnut	Very faded indeed.
"	Dull chestnut	Dull chestnut	Dulled.
G.	<i>Selenia illustriaria</i>	Deep chestnut and chocolate	Scarcely affected.

The following species are chiefly or wholly unaffected:—  
(S.) *Philaeglea athmon*, *Darapsa myron*; (R.) *Dione passifiora*; (B.) *Orgyia antiqua*, *Bimbyx quercus*; (N.) *Orthis maculenta*, *Manestra oleracea*; (G.) *Cidaria suffumata*, *Coremia ferrugata* and *minutaria*.

<sup>1</sup> These tables afford only a very condensed summary of results; for fuller details *vide Entomologist*. The initials R., B., N., G., S., T. in first column signify respectively Rhopalocera, Bombyces, Noctue, Geometra, Sphingide, and Tortrices. (\*) The asterisk (\*) against various red species signifies "reversion effect," and the mark † against certain yellow species that the "cyanide effect" has been obtained; similarly, No † that no cyanide effect can be obtained with that species.



*EXAMINATION OF THE STANDARDS OF MEASURE AND WEIGHT IMMURED IN THE HOUSES OF PARLIAMENT.*

A FORMAL examination of the standards of measure and weight which are immured in the Houses of Parliament was made on Saturday last, of which some account may possibly interest our readers.

In the "New Palace at Westminster" there were deposited in the year 1853 a copy of the "Imperial standard of the yard measure" and also a copy of the "Imperial pound weight." In the same year similar copies of the Imperial standards were also deposited with the Royal Society, at the Royal Observatory, and at the Royal Mint respectively. Such copies of the standards were deposited in accordance with the recommendations of a Commission appointed in 1843 to superintend the construction of new Parliamentary standards of length and weight intended to replace the original Imperial standards which were destroyed by the fire at the old House of Commons in 1834. The new Imperial standards were subsequently legally recognized by the Act 18 and 19 Vict. c. 72 (1855), and more recently by the Weights and Measures Act of 1878.

The Act of 1878 requires an inter-comparison of the copies of the Imperial standards which are deposited with the Royal Society, and at the Royal Observatory, and the Royal Mint, to be made once in every ten years; and such inter-comparison has been recently duly made under the directions of the Board of Trade. It appears also to be practically necessary that the standards immured at the Houses of Parliament should be examined at certain intervals, examinations having been made in the years 1865 and 1872; and the examination which was made on Saturday last in the presence of the Speaker, the President of the Board of Trade, and other representative authorities, was therefore the first that has been made for the past twenty years.

As yet we can make no reference to natural elements for the values represented by such standards as those above referred to. The earth's dimensions (as the ten-millionth of a meridian), or a physical quantity (as the length of the seconds pendulum), cannot at present be fixed or redetermined with sufficient accuracy for metrological purposes; and we have still therefore to rely on the length and weight of certain arbitrary or material standards placed in the custody of selected authorities. As all such material standards—whether made of iridium-platinum, quartz, gold, or other accepted materials—are liable to alteration by time or circumstance, it becomes the duty of the custodians of such standards to assure themselves from time to time that their standards are unaltered, so far as any intercomparison of material standards may afford evidence of their constancy; and such was the object of the examination on Saturday last, when the Board of Trade had their standards compared with those immured at the Houses of Parliament.

The history of these Parliamentary standards may be found in the classical contributions of the late Astronomer-Royal, and Prof. W. H. Miller, to the Philosophical Transactions of the Royal Society (Parts III. for 1856 and 1857); a history that has largely developed scientific inquiry in such direction, as may be instanced particularly by the creation and work of the International Committee of Weights and Measures at Paris.

On Saturday the examination of the immured standards was conducted by the officers of the Standards Department of the Board of Trade, who, for the purposes of the examination, had provided a microscopic-comparator and a balance of precision. The comparator had in it nothing new, and indicated differences of length approaching to 0.00001 inch, excepting that it was portable, so that the comparison of the immured standard yard with the Board of Trade standard might be then made

at the Houses of Parliament without the risk of removal from the building. It was, indeed, a condition of the examination that the immured standards should not be removed from the custody of the Clerk of the House. The balance used indicated differences of weight approaching 0.0005 grain, although, unlike other balances of precision, this balance was inclosed in a closely-fitting copper case, so that disturbance by currents of air might be avoided as far as possible whilst the examination was being made. The mode of comparison of the yard measure was that adopted by Baily and Sheepshanks in 1843-48, Gauss's method of weighing being followed; and the temperature and atmospheric pressure were indicated by instruments verified at the Kew Observatory.

The immured standard yard, like the Imperial yard, was found to be a bronze bar about 38 inches in length, marked "Copper 16 oz., tin 2½, zinc 1. Mr. Baily's metal. No. 4 standard yard, at 61° 98 Fahrenheit. Cast in 1845. Troughton and Simms, London"; the length of the yard, or of 36 inches, being determined by a straight line or distance between two fine lines marked on gold studs or plugs which were inserted at the bottom of two holes or wells at about half an inch below the surface of the bar. The bar was found to be supported on bronze rollers, placed under it in such manner as best to avoid flexure of the bar.

The immured pound weight, like the Imperial pound, was found to be a cylinder of platinum about 1.35 inch in height and 1.15 inch in diameter, having a density of 21.1516; and being (in 1856) 0.00314 grain lighter than the Imperial standard deposited with the Board of Trade.

Both standards were placed in mahogany boxes; the pound weight being wrapped in Swedish filtering paper, and inclosed in a silver-gilt case, which was further inclosed in a solid bronze box. The mahogany boxes were inclosed in a leaden case, which was re-inclosed in a sealed oak case.

Although the actual result of the examination on Saturday could not then be made known to those present, it was stated that the immured standards were found to be in the same condition as when they were previously examined in 1872, and were to all intents and purposes unchanged since their original deposit in 1853. The official report of the Board of Trade, which will be shortly issued, will state the full particulars of the examination.

After the comparisons of the standards had been completed, the immured standards were replaced within the oak case, which was then replaced in an inclosure or cavity prepared for it in a recess under a blank window on the right-hand side of the second landing leading from the lower waiting hall up to the Commons Committee-rooms; the rabbet of the inclosure was then covered with lime putty, the front stone being inserted and driven into close contact with the rabbet so covered, liquid plaster of Paris being poured in so as to fill all the joints of the front stone.

We are glad to see from a paper recently laid before both Houses of Parliament that the Board of Trade also possess authoritative copies (*prototypes nationales*) of the international standards of the metre and kilogramme; and that metric weights and measures—now also of the highest importance in this country—may be accurately verified by comparison with such standards.

NOTES.

MR. BALFOUR is expected to make a statement in the House of Commons this evening about the Royal Commission to which the question of a Teaching University in London is to be referred. He hopes to be able to give the terms of the reference as well as a complete list of the members of the Commission.

THE honour of knighthood has been conferred on Dr. George Buchanan, F.R.S., on his retirement from the post of Medical Officer to the Local Government Board.

THE friends and admirers of the late Mr. H. W. Bates, F.R.S., propose to give substantial expression to their regard for his character. A fund is to be raised for presentation to his widow. Any communications relating to the matter should be addressed to S. W. Silver, 3 York Gate, Regent's Park, N.W.

A BRANCH of the Royal Scottish Geographical Society has been established in London. At the first meeting, which was held on Monday, Prof. James Bryce delivered an address on "The Migrations of the Races of Men considered historically." The Marquis of Lothian, President of the London branch, occupied the chair. He said they had no intention of competing, or in any sense of vying with, the Royal Geographical Society. The Scottish Society had branches in Glasgow, Dundee, and Aberdeen; and it had been felt that another might be appropriately formed for the benefit of members in London.

THE Committee appointed to consider the question of grants to University Colleges in Great Britain have issued their Report. The principle on which they consider that the distribution of the grant to the Colleges now sharing it should be made for the remainder of the quinquennial period is as follows: (1) they award a grant to each College, varying according to the nature and extent of its University work; (2) a grant for every professor or other teacher receiving more than £250 per annum; (3) a percentage on the College income from all sources. A table is printed, giving the present grants, which the Committee wish to be continued; and the grants which they wish to be added.

THE rebuilding of the College of Agriculture, Downton, rendered necessary by the destructive fire of last year, has now been so far completed that the premises will be ready for occupation and use next term.

THE Director of the new Imperial German Zoological Station at Heligoland will be Dr. Heincke, of Oldenburg, a recognized authority on fish and fisheries. As his first assistant he will have Dr. Clemens Hartlaub (son of Dr. G. Hartlaub, the well-known ornithologist of Bremen), who will take charge of the scientific branch of the establishment. Since the death of Dr. Philip Carpenter, Dr. Clemens Hartlaub has become one of our leading authorities on starfishes. He has just published in the *Nova Acta* of the Imperial Leopoldino-Caroline Academy, an elaborate memoir on the Comatulidæ collected by Prof. Brock in the Moluccan Seas and deposited in the Göttingen Museum. In the course of this article nine species of the genera *Antedon* and *Actinometra* are described as new to science.

ON March 26, the members of the Geologists' Association, assembled at the house of Mr. W. H. Hudleston, F.R.S., President of the Geological Society, in order to inspect the handsome private museum he has attached to his residence. The occasion was rendered particularly interesting by the fact that the Council of the Association had decided to take this opportunity of presenting to Mr. Hudleston an illuminated address expressing its sense of the helpful interest he had always shown in the work of the Association. Among those present were many former Presidents and officers of the Association, who now rank as leaders of geological science. Although at least one hundred persons had been concerned in the arrangement of the testimonial, the secret was so well kept that the presentation came as a complete surprise to its intended recipient. The signatures of the address had been selected to represent all grades of past and present workers of the Association. In making the

presentation, the present President of the Geologists' Association, Rev. Prof. J. F. Blake, after suitably referring to Mr. Hudleston's eminent services to geological science, expressed the particular pleasure he felt that it should have fallen to his share to hand a testimonial so richly deserved to his old colleague and fellow-worker. Mr. Hudleston, in the course of a well-chosen reply, referred to the curious coincidence that of the authors of the joint work of Blake and Hudleston many years ago, the one was President of the Geologists' Association and the other of the Geological Society during the same year. The contents of Mr. Hudleston's museum, now in course of arrangement, excited considerable interest, particularly the minerals, many of the choicest specimens of which are from the private collection of the late Prof. J. Tennant, and also the extensive series of British Jurassic Gasteropoda collected by the author for the monograph now in course of publication by the Palæontographical Society.

MR. J. P. BARRETT, chief of the department of electricity in connection with the Chicago Exhibition, has issued a pamphlet containing all the information that can be needed to enable intending exhibitors to proceed intelligently. He will be glad to give special information to any one who may want it, and invites correspondence.

A BODY called the Scientific Alliance was recently organized at New York. It consists of six societies engaged in the promotion of research, and two others will probably soon be added. The six societies are the New York Academy of Sciences, the Torrey Botanical Club, the New York Microscopical Society, the Linnean Society of New York, the New York Mineralogical Club, and the New York Mathematical Society. According to *Science*, these societies do not in any way sink their individuality or surrender any part of the management of their own affairs. Their union is merely in the way of co-operation for the advancement of science, and for mutual encouragement, carried out through a central representative body, known as the Council, having advisory powers only. The Council is made up of the president and two other delegates from each society. A monthly bulletin is issued under the authority of the Council, announcing the proposed proceedings of all the societies, and a copy of this bulletin is sent to every member. The bulletin contains an invitation to the members to attend any of the meetings. An annual directory is issued, and it is proposed that there shall also be an annual report on the work done. *Science* says that the brief experience of the Alliance has convinced the members that still closer union is necessary, and this feeling has led to a movement for the securing of a permanent building as a home for all the societies. It is hoped that a building may be erected in a central part of New York, "large enough to afford each society rooms for its ordinary meetings, for its library and collections, as well as facilities for research, and also to contain a lecture hall, capable of seating twelve hundred people, to be used by all the societies in their public work."

WE have referred in the astronomical column to the astronomical observations recorded in the "Washington Observations for 1887." We will here briefly summarize the contents of this volume with regard to the other observations there tabulated. Appendix I. contains a report upon some of the magnetic observatories of Europe, which was made by C. C. Marsh, who was commissioned to pay special attention to the instruments, buildings, methods of observing, and the question of the reduction of the observations. In this report, which was considerably cut short, owing to the author having to proceed to sea on his return, much interesting and valuable material has been collected which should be consulted by all those who are connected with the taking of such observations, and with the construction of

magnetic observatories. The plates which accompany the text show plans of heating and ventilating the Pavlovsk and Potsdam Observatories, the cellar and ground plans of the latter, and details of instruments used in other Observatories. In the second and third appendices will be found all the magnetic and meteorological observations made in the years 1890 and 1883-87 respectively; these are brought together in a way that will be found most convenient for reference, while several plates showing the mean diurnal variations of some of the magnetic elements have been added. All the above-mentioned observations have been reduced in the usual way, and the results obtained are here tabulated.

ON Thursday and Friday, last week, a tornado passed over the North-Western States of America and caused enormous damage and great loss of life, in some cases whole towns being devastated. It is said to have been the most far-reaching and destructive storm ever known to have occurred in these regions. Texas, Kansas, Missouri, Iowa, and Nebraska suffered most.

In the Annual Report for 1892 of the Berlin branch of the German Meteorological Society, Prof. G. Hellmann gives an account of his continued experiments on the effects of exposure on rainfall records, and on the determination of the distance apart that rain-gauges should be erected in order to obtain an accurate account of the rainfall of any district. Simple as the question appears, the experiments, which have been carried on for seven years, have not sufficed to give a definite answer. Very considerable differences are found in the amounts recorded at stations comparatively close to each other. This result is partly owing to the effect of wind, especially in the case of snow. The following are the most important conclusions derived from the experiments:—(1) The more a rain-gauge is exposed to the wind, under otherwise similar circumstances, the less rainfall it records, and the higher a gauge is placed above the ground, the less rain it catches, as the disturbing influence of the wind is greater than on the surface of the ground. But if properly protected from the wind, a gauge will give useful results in an elevated position. The usual instructions to erect the gauge as openly as possible are therefore incorrect. (2) Even in a flat country, differences of 5 per cent. occur in different months, at stations a quarter of a mile apart; in stormy weather, especially during thunderstorms, the difference may amount to 100 per cent. The amounts recorded at neighbouring stations agree better together in spring and autumn, and also in relatively wet years. Further experiments are needed, if possible by means of anemometers erected at the same level as the rain-gauges, to determine more accurately the effect of wind on both rainfall and snow.

IN connection with the celebration of the fourth centenary of the discovery of America by Columbus, the Italian Botanical Society invites the attendance of botanists of all countries at a Botanical International Congress, to be held at Genoa, from the 4th to the 11th of September. In addition to the meeting for scientific purposes, there will be excursions on the shores of the Mediterranean and in the Maritime Alps; and during the same time will also take place the inauguration of the new Botanical Institute built and presented to the University of Genoa by the munificence of Mr. Thomas Hanbury, of La Mortola, and the opening of an Exhibition of Horticulture. All communications should be addressed to Prof. Penzig, of the University of Genoa.

HARVARD UNIVERSITY is indebted to the munificence of Prof. George L. Goodale, the Director of the Botanic Garden at Cambridge, Mass., for a remarkable development of the botanical establishment of the University during the last ten years. It has acquired a large fire-proof Museum, to contain not only its collections, but its lecture-rooms and laboratories; has

added greatly to its collections and its library; and has also obtained larger permanent funds for its support.

In a report on the Great Skua in Shetland during the season of 1891, printed in the new number (the second) of the *Annals of Scottish Natural History*, Mr. W. E. Clarke says that the attention which was called to the persecution of the Great Skua, at the close of the disastrous breeding season of 1890, was the means of doing much good. It aroused and secured the interest and influence of ornithologists and others on behalf of the bird's future welfare and its preservation as an indigenous British species. He notes that the number of Skuas resorting to Foula annually during the summer may be estimated at not less than 120 individuals. Of these, two-thirds are to be reckoned as breeding birds.

MESSRS. MACMILLAN AND CO. have issued a second edition of Mr. A. R. Wallace's well-known "Island Life, or the Phenomena and Causes of Insular Faunas and Floras." The work has been carefully revised throughout, and, owing to the great increase to our knowledge of the natural history of some of the islands during the last twelve years, considerable additions and alterations have been required.

THE paper on the opium question, recently read by Mr. G. H. M. Batten before the Society of Arts, is printed in the current number of the Society's journal. It is followed by a report of the animated discussion to which it gave rise, and by statements which would have been submitted to the meeting by various gentlemen if there had been time. Mr. Batten cites the opinion of a number of "independent persons of high character and reputation," to the effect that "the daily use of opium in moderation is not only harmless but of positive benefit, and frequently even a necessity of life"; and that "this moderate use is the rule, and excess the exception." Persons who have arrived at an opposite conclusion have had an experience, he thinks, almost entirely confined to towns and the sea coast. "They knew little or nothing of the millions of the healthy, industrious population in the interior of the country to whom the use of opium is as common, as moderate, and as beneficial as that of beer is to the people of England."

A WRITER in *Nature Notes*, calling attention to "the iniquity of rooting up wild flowers to sell them to English dealers," says he could name a district in the Basses Pyrénées, where not a single wild daffodil is now to be found. The flower was once abundant there, but an English resident chose to bargain with a well-known dealer, to furnish him with roots; and this has been attended by grave injustice to France.

MR. G. C. GREEN records in *Nature Notes* for April a curious reminiscence with regard to a pair of jackdaws kept by him at Modbury Vicarage, South Devon, about twenty years ago. They had been taken from the nest, and during the first summer their wings were slightly clipped. After this their wings were allowed to grow, and they lived at full liberty in the garden. They were perfectly tame, and would come at call and feed out of the hand, would come into the house, and in the morning knock at the windows to ask for some breakfast. In the spring they used to fly away and join their wild companions, make their nests, and rear a family; but when this was over they came back to the garden again, fed from the hand, and were as tame as ever. But the curious thing was, that after one or two seasons they brought another jackdaw with them, presumably the young of one of them, which was just as tame as themselves, although nothing had ever been done to tame it, so that it was impossible to tell which were the original favourites, and which was the new one. Moreover, when after a few years one of these jackdaws was accidentally killed, another was brought by the other two.

MR. W. W. SMITH, writing to the new number of the *Entomologist* from Ashburton, New Zealand, says that he has for twelve years successfully used hellebore as an insecticide. It is used annually by many orchardists in the South Island for destroying the larvæ of *Tenthredo* (*Selandria*) *cerasi*. Mr. Smith uses it in the proportion of half an ounce to a bucket of water. When he notices the newly-hatched larvæ on the leaves, he carefully and effectually syringes the trees with the solution, choosing a calm day for doing so. The larvæ are equally common on the cherry-, plum-, and pear-trees, and rapidly destroy the foliage if they are not checked or destroyed. One good syringing suffices. When the trees are syringed early, the imago sawfly is prevented from laying eggs further on the foliage, and by this course much labour is avoided. He does not go over the trees syringing a second time with pure water, as the particles of powder left adhering to the foliage are invariably washed off by rains before any of the fruit ripens.

MR. J. W. FEWKES contributes to the January number of the *American Naturalist*, just received, an interesting paper on the ceremonial circuit of the cardinal points among the Tusayan Indians. During the progress of the secret ceremonials which are performed in the Kib-vas or Estufas at Hual-pi, and other pueblos of the old province of Tusayan, it is customary for a priest to pass on the north side of the fire-place as he approaches the altar, and on the south as he passes from the altar to the ladder. This custom is conscientiously followed by the older priests, especially when taking part in important ceremonials; and Mr. Fewkes has seen novices, and even old priests, corrected and sent back when they had violated this simple Kib-va custom. The four directions do not correspond with the true cardinal points. The so-called Kwi-ni-wi-ke of the Hopi is neither the magnetic nor the polar north, but about north-west, or 45° west of north, and the other points vary in the same ratio. Mr. Fewkes thinks that a ready explanation of this is found in the orientation of the Kib-vas, which, in turn, depends on the extension of the mesa upon which Hual-pi is situated—or, speaking more accurately, as he says in a note, on the direction of the lines of fissure of the rock of which the mesa is built up. The ceremonial circuit is constantly followed in the preparation of so-called medicine. When a priest pours the liquid of which it is made into the terraced rectangular bowl, preparatory to placing the other ingredients in it, he pours the fluid first on the north side, then on the west, then on the south, then on the east side of the bowl. The ceremonial circuit is followed in connection with many other observances noted by Mr. Fewkes. He also remarks that the following colours correspond to the four cardinal points (bearing in mind that the Hopi north is really north-west): north, yellow; west, blue (represented ceremonially by malachite green); south, red; east, white. The priest of the antelope assemblage, in making the sand mosaic picture a few days before the snake dance, first makes the yellow border, then the green, then the red, then the white. The north line of the yellow is followed by the west of the same colour, then the south, then the east. The same sequence occurs when he outlines and makes the body of the semicircular clouds in the centre of the mosaic (dry painting). The lightning serpents of the four colours are made in the same order of the colours. It is interesting to note, as Mr. Fewkes says, that the ceremonial circuit is opposite that of the sun in its daily course in the sky. He thinks it is probably more than a coincidence that it is the same circuit which the snake and antelope priests take when they move about the place, and the latter carry the snakes in their mouths.

LAST year Dr. J. T. Rothrock received from the American Philosophical Society a grant of 300 dollars to defray part of the expenses of a trip to the West Indies. The object was the

collecting of photographs and information which could be utilized in the preparation and delivery of the annual lectures popularly known as "the Michaux forestry course." About 150 good negatives were obtained, and there are about 75 satisfactory illustrations of the trees, physical geography, and topography of the islands visited. The trip lasted three months. Dr. Rothrock was particularly struck by the contrast between the Bahamas and Jamaica. In the course of some interesting observations printed in the latest instalment of the Proceedings of the American Philosophical Society, he points out that the Bahamas are low and show no considerable elevation, while Jamaica reaches a maximum altitude of 7360 feet above the sea-level. The soil of the Bahamas is scanty, and consequently cultivation entails fertilization. That of Jamaica is of great depth, and its continued productiveness is evidence of a vast natural fertility. The flora of the Bahamas shows marked resemblance to that of Florida. The flora of Jamaica is essentially tropical, save at such altitudes as suit plants of cooler regions. In such places are found the common chickweed (*Stellaria media*), the white clover (*Trifolium repens*), associated with plants from the cooler parts of southern regions. The mangrove (*Rhizophora mangle*), common to the tropical seas around the globe, attains in Jamaica (compared with that in Florida and in the Bahamas) a surprising height. Near Port Morant are large jungles, where the trees attain a height of at least 60 feet. Dr. Rothrock calls attention to possible tannin production from the mangrove. No tree in North America, he says, at all approaches the mangrove in the percentage of tannin it contains. That the mangrove should have remained so long unutilized is due to the difficulty of obtaining its tannin free from colouring matter. Dr. Rothrock thinks that in the near future, owing to exhaustion of other tannin-producing trees, the arts will be forced to draw upon the mangrove, even if an improved chemistry is not able to free it from this objectionable colour. The natives obtain a red-brown dye from the bark by simply steeping it in water.

MR. T. SOUTHWELL, Norwich, records in the April number of the *Zoologist* that he was lately informed, by Mr. D. C. Burlingham, of the occurrence of a male Greenland shark, (*Lemargus borealis*), which measured 14 feet 2 inches in length and weighed 1¼ tons, at Lynn, on the 21st of January last. It was found stranded on a sand-bank on the east side of the Balldog Channel, and was brought up to Lynn by a fishing-smack, being still alive when Mr. Burlingham saw it. It was subsequently exhibited at Cambridge, and its owner intended to take it to Huntingdon, Peterborough, and elsewhere. This species is of rare occurrence on the Norfolk and Suffolk coast, and the present example is only the fourth of which Mr. Southwell has notes.

DR. E. RÁTHAY states that the galls of *Cynips calycis*, produced on *Quercus pedunculata*, attract, by their viscid secretion, a number of small ants, which he believes to be advantageous to the tree, in killing quantities of caterpillars and other insects which are its natural enemies. He illustrates the value of this protection by the statement that the inhabitants of a single ants' nest may destroy in a single day upwards of 100,000 insects.

In the *Bullettino* of the Italian Botanical Society, Signor F. Pasquale proposes a new theory of the morphology of the carpel in flowering plants, founded on an extended observation of the course of the vascular bundles. According to him, a carpel is not a single modified leaf, but is the result of the concurrence of three, less often of two, leaves, which take part in the formation and in the nutrition of the ovules and of the seeds. The carpel is therefore a *triphyllole*, of which one leaf (the inferior one) is sterile, and the other two (superior) are fertile; and between these there is an intimate fusion, with complete anastomosis of the vascular bundles. Each fertile

leaf is composed of a membranous portion, the *placental hemiphyll*, and an *ovular hemiphyll*, which is entirely transformed into the ovules with their funicles, together with the style and stigma. The placental hemiphyll also takes part in the formation of the pericarp and septa. The ovules originate from the whole of the ovular hemiphyll, and not merely from the carpellary margins or teeth.

WE notice the appearance of a very useful work, in Russian, by Prof. Samokvasoff, on Russian prehistoric antiquities, under the title of "Foundations of a Chronological Classification of Antiquities, and Catalogue." As seen from the title, the work consists of two parts: a catalogue of the very rich collection of the Russian Professor, partly illustrated, and a general description of the various epochs which may be distinguished in the relics of the past on the territory of Russia. He has no difficulty in showing that the Slavonians of the first centuries of our era were by no means mere savages. The burial places of that period, usually situated close to the earthen forts, some of which must have required the work of a considerable population, contain hundreds and thousands of graves, so that it is certain that the Slavonians of that period were living in large societies, and had their fortified towns. The same burial customs prevailed over large areas, but the treasures now unearthed from various graves show that differences of wealth and social position existed at that time as well. Considerable amounts of Greek, Roman, and Arabian gold and silver coins were found in the graves, the metal alone of the coins found in some graves attaining, at its present prices, the value of several hundred pounds; while numbers of objects of art, of Greek, Roman, Byzantine, and Arabian origin, are proofs of the brisk foreign trade which took place at that time. The graves of the pagan Slavonians contain flax, woollen, silk, and gold-embroidered tissues; ornaments in gold, silver, bronze, and bone; iron weapons and parts of armament; gold, silver, bronze, iron, and clay vessels, and so on; while the sickles and the grains of wheat, oat, and barley which were found in the graves of South Russia, together with small idols and other objects devoted to pagan worship, are proofs of agriculture having been carried on during the pagan epoch.

TWO new liquids containing fluorine have been synthesized by M. Meslans. They are halogen derivatives of glycerin, and were obtained by allowing allyl fluoride, a gaseous substance recently described by M. Meslans, to react with chlorine and bromine. Allyl fluoride,  $C_3H_5F$ , is readily prepared by the gradual addition of allyl iodide to dry silver fluoride. It is a colourless gas of peculiar odour, which burns with a luminous flame upon ignition, with liberation of vapour of hydrofluoric acid. When a jet from which chlorine is escaping is brought into a vessel filled with allyl fluoride, combination at once ensues, and drops of a colourless liquid commence to be deposited upon the walls of the vessel. In order to obtain the liquid in greater quantity a large flask is employed, through the caoutchouc stopper of which pass two tubes, one delivering chlorine and the other allyl fluoride. Considerable heat is developed during the act of combination, hence the flask is immersed in a bath of cold water. A slight excess of chlorine is maintained during the reaction, and the liquid which rapidly collects is consequently coloured green; but when sufficient has been accumulated the supply of chlorine is first arrested in order that the excess of that gas, which produces the green coloration, shall be converted to the colourless liquid by the still-issuing allyl fluoride and the liquid thus decolorized. The colourless mobile liquid so obtained is then submitted to distillation, when practically the whole passes over into the receiver between  $122^\circ$  and  $123^\circ$ . If the synthetical preparation is conducted volumetrically, it is found that equal volumes of allyl fluoride and chlorine unite;

the resulting liquid [therefore presumably possesses the composition  $C_3H_5FCl_2$ , an assumption confirmed by a determination of vapour density which yielded the number 4.50, the vapour density calculated from this formula being 4.51. The compound is indeed a derivative of glycerin, its constitution being probably  $CH_2Cl-CHCl-CH_2F$ , and may be termed dichloro-fluorohydrin.

THE second new compound is analogous to the one just described, and resembles it very closely in properties. It is obtained by the direct union of bromine with allyl fluoride. If a few drops of bromine are allowed to fall into a vessel filled with allyl fluoride, the latter is rapidly absorbed with considerable rise of temperature, the red colour of the bromine simultaneously disappearing. To prepare the liquid in quantity, allyl fluoride is allowed to stream slowly into a quantity of bromine contained in a cooled flask, the operation being continued until the red colour of the liquid has entirely disappeared. The colourless liquid thus obtained distils without decomposition at  $162^\circ-163^\circ$ . The data afforded by determinations of the bromine content and the vapour density point to the formula  $C_3H_5FBr_2$ . Both the liquids above described appear to be very stable compounds, for even during their distillation the glass vessels containing them exhibit no signs of etching. They are miscible with ether, and readily soluble in absolute alcohol, but they are almost perfectly insoluble in water. They possess pleasant odours, somewhat reminding one of chloroform, and are sweet but burning in taste. They are incombustible, but at a high temperature the vapours burn with liberation of hydrofluoric and hydrochloric or hydrobromic acids.

THE additions to the Zoological Society's Gardens during the past week include a Guinea Baboon (*Cynocephalus sphinx* ♀), a Bateleur Eagle (*Helolarsus ecaudatus*), a Puff Adder (*Vipera arietans*) from South Africa, presented by Mr. Keith Anstruther; a Japanese Deer (*Cervus sika* ♀) from Japan, presented by Sir Douglas Brook, Bart.; a Wedge-tailed Eagle (*Aquila audax*) from Australia, presented by Miss Carr; a Tawny Owl (*Syrnium aluco*), European, presented by Mr. E. A. Rocheda; a Puff Adder (*Vipera arietans*) from South Africa, presented by Mr. D. Wilson; two Common Vipers (*Vipera berus*), British, presented by Mr. W. H. B. Pain; a Shielded Eryx (*Eryx thebaicus*) from North Africa, deposited; four Topela Finches (*Munia topela*) from China, a Black-necked Swan (*Cygnus nigricollis*) from Antarctic America, purchased.

#### OUR ASTRONOMICAL COLUMN.

THE RELATIVE MOTION OF 61 CYGNI.—The large proper motion of 61 Cygni, combined with its remarkable duplex character, renders it an object of great interest. Doubts have been expressed, however, as to whether the two components are really connected by a bond of mutual attraction, and it has been assumed that they will gradually separate and traverse widely different paths in space. Prof. A. Hall has brought together all the observations which have been made of the position-angle and distance of the star since 1825, and has investigated them with a view of settling this question (*Astronomical Journal*, No. 258). The result is in favour of the physical connection of the two stars, but all that can be said of the period of revolution is that it is very long. The mass of the brighter star appears to be 3.4 times that of the companion.

THE TEMPERATURE OF THE SUN.—Numerous attempts have been made to determine the sun's temperature, and the results obtained range from  $1500^\circ$  to  $5,000,000^\circ$ . The enormous differences that exist between the different estimates result from the fact that different laws have been assumed to represent the rate of radiation. M. H. Le Chatelier communicated the latest contribution to the subject at the meeting of the Paris Academy of March 28. His experiments show that the intensity

of the radiations emitted by an incandescent body of which the emissive power is unity is expressed by the formula—

$$I = 10^{87} T \frac{3210}{T}$$

The temperatures employed range from 680° to 1770°, and these, with the observed intensity of radiation, have been used to plot a curve. By extending the curve and measuring the intensity of the radiation from the sun, an estimation of 7600° as the effective solar temperature is obtained. The term effective temperature is used to express that temperature which a body having an emissive power equal to unity should possess, in order to send out radiations of the same intensity as the sun. The real temperature of the photosphere is higher than 7600°, because its radiations are absorbed by the cooler solar atmosphere, and it may be, also, because the emissive power of the sun is less than unity.]

COMET SWIFT, MARCH 6.—The following ephemeris for this comet is given in *Astronomische Nachrichten*, No. 3082, for 12h. Berlin mean time:—

1892.	R.A.	Decl.
April 8 ...	21 16 41	+0 33' 6"
" 9 ...	21 20 18	1 34' 2"
" 10 ...	21 23 54	2 34' 3"
" 11 ...	21 27 28	3 33' 8"
" 12 ...	21 31 0	4 32' 7"
" 13 ...	21 34 30	5 30' 9"
" 14 ...	21 37 59	6 28' 4"
" 15 ...	21 41 25	7 25' 2"

WOLF'S COMET, 1891 II.—In *Astronomische Nachrichten*, No. 3082, an ephemeris for this comet is given by Herr Dr. Thraen, of which the following is an extract (12h. Berlin mean time):—

1892.	R.A.		Decl.
	h. m.	s.	
April 8 ...	5 53	19' 13"	-0 12' 43' 2"
" 9 ...	5 54	49' 39"	-0 7' 21' 8"
" 10 ...	5 56	19' 84"	-0 2' 7' 1"
" 11 ...	5 57	50' 48"	+0 3' 0' 9"
" 12 ...	5 59	21' 29"	+0 8' 2' 1"
" 13 ...	6 0	52' 27"	+0 12' 56' 6"
" 14 ...	6 2	23' 43"	+0 17' 44' 3"
" 15 ...	6 3	54' 78"	+0 22' 25' 1"

PERIODIC PERTURBATIONS OF THE FOUR INNER PLANETS.—In the astronomical papers which are prepared for the use of the American Ephemeris and Nautical Almanac (vol. iii., part v.), most valuable computations of the periodic perturbations of the longitudes and radii vectores of the four inner planets of the first order as to masses are contributed. Prof. Newcomb, under whose directions these computations were made, tells us in the introductory note that in the preparation of the fundamental data for the new tables, all the coefficients, which are included in the expressions for the general perturbations, were redetermined: the values obtained for them agreed well with those obtained by Leverrier, and prove that their accuracy is placed beyond doubt.

To eliminate any errors that might have been made, duplicate computations were undertaken, and the results of them both are given in the final expressions for the perturbations in longitude. It may be stated that the complete theory is not here published, the secular variations, perturbations of the latitude, and those of long period in the longitude, not being printed, owing to their unfinished state.

N.P.D.'S OBSERVED WITH GREENWICH AND WASHINGTON TRANSIT CIRCLES.—Prof. Newcomb, under whose direction these computations were made, gives in vol. ii. part vi. of the same series of papers just referred to an interesting discussion on the differences that have been found in these observations. Those made with the Greenwich circle cover a period of thirty-six years, from 1851-87, while the Washington observations are included in the years 1866-86. The author has a firm basis here, on which he can rely, for in the former series the same methods of reduction and observation were in use for this entire period without interruption. He inquires first of all into the conclusions which can be gathered from the stability of the instrument, from both direct and reflection observations, and finds that the R-D corrections are mainly due to flexure. The constant of refraction and the possible periodic error due to those in the graduation of the circle are then dealt with, together with corrections for reductions to the equinox during the years 1851-56. The hypothesis of the

secular change in the latitude is here considered as too improbable for acceptance with our present data, so that the apparent variations are here supposed to be due to the changes in the instrument or habits of the observers. In the section on the latitude of the Royal Observatory, he finds that the co-latitude derivable from observations of the four polar stars during the period 1877-86 is greater by 0".31 than that derivable from observations of all circumpolar stars. At the conclusion of this investigation he gives a table showing the corrections to the north polar distances, derived annually from the observations with the Greenwich transit circle, to reduce them to the instrumental standard of the present paper, and the Pulkowa refractions.

WASHINGTON OBSERVATIONS, 1887.—All the observations which were made during the year 1887 at the United States Naval Observatory are included in this volume. The introduction, besides giving the report of the Superintendent on the state of the Observatory generally, contains all the detailed information relative to the methods of computing the observations made with the transit circle, meridian transit instrument, and the 26-inch and 9.6-inch equatorials. The principal work of the transit circle during this period has been upon the sun, moon, and planets, and miscellaneous stars. These last, included stars of the American Ephemeris for clock corrections, &c.; stars whose occultations were observed at this Observatory, and by the various American parties that observed the 1874 transit of Venus; those selected for standard stars in the formation of the catalogue made from 1846-49; and stars of the B.A.C. between 120° 0' and 131° 10' N.P.D. that have not been observed three times in R.A. and declination at Washington. The meridian transit instrument was devoted to the determination of the errors of the standard mean time clock in connection with the transmission of time, and 1645 transits were taken. The clock's rate was found satisfactory, its variations following closely those of the barometer. The 26-inch and 9.6-inch equatorials have been also used, the former for observations of double stars and small stars in the Pleiades, the latter for comets. Besides these, many other magnetic and meteorological observations are recorded, but a brief account of them will be found in the notes.

#### FERTILIZATION OF THE CASUARINACEÆ.

FEW recent articles in botanical literature can compare in interest and importance with that contributed by Dr. Melchior Treub to the tenth volume of the *Annales du Jardin Botanique de Buitenzorg*, "On the *Casuarinaceæ*, and their Position in the Natural System." The startling announcement is made of the occurrence of a mode of fertilization of the ovule essentially different from that which takes place in other flowering plants.

The species of the genus *Casuarina*, which alone make up the order, are about twenty-three in number, and are trees, nearly all natives of Australia, where they are known as "beef-wood trees," characterized by their jointed, almost leafless branches. From the catkin-like inflorescence of very imperfect flowers, they are generally placed among Incompletæ or Monochlamydeæ, near to Myricaceæ and Juglandaceæ. The female flower is composed of two carpels, without either calyx or corolla, and has at the base an ovarian cavity, in which are formed (in *C. suberosa*) the two ovules with parietal placentation, but connected from the first with its summit by cords of cellulose. Corresponding to the style in most plants, is an axial mass of tissue which M. Treub calls the styler cylinder, surrounded by a peripheral region containing tracheides, and terminating in two elongated stigmas. The two ovules are unequal in size, and coalesce in their growth by their placental portions; the connection between them and the base of the styler column is called the bridge; they are also connected with the base of the ovarian cavity by their funicles.

The processes which take place within the ovule up to the time of the formation of the embryo-sac are very different from those hitherto observed in Angiosperms. Several large hypodermal cells, the archesporic-cells, at the summit of the nucellus, divide tangentially; and two of the cells thus produced towards the inner side, the primordial mother-cells, divide further, giving rise to a thick cylinder of large cells occupying the centre of the nucellus, the spogenous tissue, surrounded by flattened cells corresponding to the "Tapetenzellen" of Goebel. The cells of the spogenous tissue are equivalent to the mother-cells of the embryo-sac in other Angiosperms. These cells divide transversely into large megasporos (macrospores); the small inactive

cells become absorbed. In *C. glauca* and *Rumphia*na tracheides are formed, analogous to the elaters of the Hepaticæ; their function is uncertain. The megasporcs, or embryo-sacs, of which there are usually from sixteen to twenty, lengthen in the direction of the chalaza, some of them sometimes penetrating and forming "tails" between the elements of the fibrovascular bundle of the funicle. The sister-cells of the embryo-sacs, instead of being absorbed at an early period, as in other Angiosperms, disappear only much later. The megasporcs which develop fully divide at the end into two or three cells, which are in most cases naked, and result from the division of a single cell. In the great majority of cases only a single megaspore in each nucellus has these terminal or sexual cells furnished with cell-walls; this is the future embryo-sac. The oosphere is always formed from the sexual cell which has the thickest wall. No antipodals are formed.

Only a single ovule is ever fertilized, and the pollen-grain which fecundates it advances towards the embryo-sac in a way entirely different from anything that occurs in other Phanerogams. The pollen-tube does not enter the ovarian cavity; it descends the stylary cylinder, crosses the bridge and the tissue which unites the ovule with the wall of the ovary, and arrives at the fibrovascular bundle which leads to the chalaza, where it produces two short branches, then traverses the chalaza, and enters the ovule by means of the "tail" of a sterile megaspore, and continues its course towards the embryo-sac. Towards the middle of the nucellus it contracts, tapers off, and ruptures, the terminal fecundating portion becoming separated from the rest of the pollen-tube. This portion, which has a thickened wall, and contains distinct protoplasm, never enters the micropyle or the embryo-sac, but becomes firmly attached to the wall of the latter, at a spot variable in position, but always at some distance from the sexual apparatus. Dr. Treub has not, at present, been able to detect in this portion a definite nucleus, or to follow the actual process of fecundation. During the development of the embryo-sac, numerous endosperm-nuclei are formed, and subsequently the embryo makes its appearance. The mode of development of the embryo does not differ from that which occurs in other Dicotyledones.

The peculiar processes which accompany the act of fecundation, and the presence of a large number of megasporcs, each containing a sexual apparatus, induce Dr. Treub to regard the Casuarinacæ as a distinct group of Angiosperms, of equal rank with the Monocotyledones and Dicotyledones together, and he proposes the following primary classification of Phanerogams:—

## I. GYMNOSPERMS.

## II. ANGIOSPERMS.

## A. CHALAZOGAMS (Casuarinacæ).

## B. POROGAMS.

1. *Monocotyledones*.
2. *Dicotyledones*.

The Chalazogams are not intermediate between Gymnosperms and Angiosperms, but occupy an isolated and inferior position among the latter, somewhat analogous to that of *Lycopodium* among Vascular Cryptogams. The paper is illustrated by 21 fine plates. A. W. B.

## UNIVERSITY AND EDUCATIONAL INTELLIGENCE.

OXFORD.—*Endowment of Original Research*.—The following notice has been received by the Vice-Chancellor:—A gentleman has established a Scholarship of £100, tenable for one year, for the encouragement of original research. The Scholar will be selected by a Committee composed of Dr. George Thin, Surgeon-General Cornish, and Prof. A. Winter-Blyth. The conditions of the Scholarship are, that the research be on a subject requiring for its elucidation both chemical and bacteriological methods, and the subject will be selected by the Committee of Selection. With the concurrence of the Scholar, the work is to be done in the laboratories of the College of State Medicine, 101 Great Russell Street, W.C., and the Scholar will be made to devote his whole time to the work. Application to be made to Surgeon-General Cornish, on or before April 18, 1892.

In a Convocation held on April 5, it was decreed (the Council of the Royal Geographical Society having offered a further sum of £150 a year, to be met by an equal sum from the University, for the payment of a Reader in Geography

during the next five years) that the offer be accepted, and that the thanks of the University should be conveyed to the Council of the Royal Geographical Society for their liberal offer.

The programme of the fifth summer meeting of University Extension and other students, to be held in Oxford in July and August 1892, has been issued, and in its general character resembles that of last year. The inaugural lecture will be delivered by Mr. John Addington Symonds (if his health permits) on Friday, July 29, at 8.30 p.m. The meeting will, as in former years, be divided into two parts, viz. from July 29 to August 9, and from August 10 to August 26. In Natural Science the following arrangements have been made:—

In Chemistry: a course of eighteen days' practical instruction in the University laboratory, limited to 100 students, conducted by Messrs. J. E. Marsh and A. D. Hall of Balliol College.

In Geology: a special course of fourteen days' practical instruction, with field work provided, if at least 40 students offer themselves.

In Botany: in addition to lectures on primroses and their relations, it is proposed to arrange, for a class of not less than 40 students, a three weeks' course of practical instruction.

In Biology: to the same minimum number of students is offered a special course of lectures and demonstrations in the physiological laboratory, to form an introduction to the study of life, and especially of nervous organisms.

Courses of lectures and instruction on Astronomy, Mechanics, Sound, Light and Heat, Electricity, Physiography, and Hygiene can be arranged.

It is also announced that there will be no summer meeting in 1893, as during August in that year the Examination Schools will be in the hands of workpeople.

ST. ANDREWS.—*Summer Session*.—A course of lectures in zoology and botany, qualifying for graduation, will commence on May 2, the former by Prof. Prince, the latter by Mr. Robertson, the University Lecturer on Botany. These are open to students of either sex.

## SOCIETIES AND ACADEMIES.

## LONDON.

Royal Society, March 31.—"Aberration Problems: a Discussion concerning the Connection between Ether and Matter, and the Motion of the Ether near the Earth." By Oliver Lodge, F.R.S., Professor of Physics, University College, Liverpool.

The paper begins by recognizing the distinction between ether in free space and ether as modified by transparent matter, and points out that the modified ether, or at least the modification, necessarily travels with the matter. The well-known hypothesis of Fresnel is discussed and re-stated in modern form.

Of its two parts, one has been verified by the experiment of Fizeau, the other has not yet been verified. Its two parts are, (1) that inside transparent matter the velocity of light is affected by the motion of that matter, and (2) that immediately outside moving matter there is no such effect. The author proceeds to examine into the truth of this second part, (1) by discussing what is already known, (2) by fresh experiment.

The phenomena resulting from motion are four, viz.:—

(1) Changes in direction, observed by telescope and called aberration.

(2) Change in frequency, observed by spectroscope and called Doppler effect.

(3) Change in time of journey, observed by lag of phase or shift of interference bands.

(4) Change in intensity, observed by energy received by thermopile.

After a discussion of the effects of motion in general, which differ according as projectiles or waves are contemplated, the case of a fixed source in a moving medium is considered; then of a moving source in a fixed medium; then the case of medium alone moving past source and receiver; and, finally, of the receiver only moving.

It is found that the medium alone moving causes no change in direction, no change in frequency, no detectable lag of phase, and probably no change of intensity; and hence arises the difficulty of ascertaining whether the general body of the ether is moving relatively to the earth or not.

A clear distinction has to be drawn, however, between the effect of general motion of the medium as a whole, and motion

of parts of the medium, as when dense matter is artificially moved. The latter kind of motion may produce many effects which the former cannot.

A summary of this part of the discussion is as follows:—

Source alone moving produces a real and apparent change of colour; a real but not apparent error in direction; no lag of phase, except that appropriate to altered wave-length; a change of intensity corresponding to different wave-lengths.

Medium alone moving, or source and receiver moving together, gives no change of colour; no change of direction; a real lag of phase, but undetectable without control over the medium; a change of intensity corresponding to different distances but compensated by change of radiating power.

Receiver alone moving gives an apparent change of colour; an apparent change of direction; no change of phase, except that appropriate to extra virtual speed of light; change of intensity corresponding to different virtual velocity of light.

The probable absence of a first order effect of any kind, due to ethereal drift or relative motion between earth and ether, makes it necessary to attend to second order effects.

The principle of least time is applied, after the manner of Lorentz, to define a ray rigorously, and to display the effect of existence or non-existence of a velocity potential. Fresnel's law is seen to be equivalent to extending the velocity potential throughout all transparent matter.

It is shown that a ray traversing space or transparent substances will retain its shape, whatever the motion of the medium, so long as that motion is irrotational, and that in that case the apparent direction of objects depends simply on motion of observer; but, on the other hand, that if the ether drags with it some of the ether in its neighbourhood, stellar rays will be curved, and astronomical aberration will be a function of latitude and time of day.

The experiment of Bosovich, Airy, and Hoek, as to the effect of filling a telescope-tube with water, does not discriminate between these theories. For if the ether is entirely non-viscous and has a velocity potential, stellar rays continue straight, in spite of change of medium (or at oblique incidence are refracted in the simple manner), and there will be no fresh effect due to change of medium; while, if, on the contrary, the ether is all carried along near the earth, then it is stationary in a telescope tube, whether that be filled with water or air, and likewise no effect is to be expected. In the case of a viscous ether, all the difficulty of aberration must be attacked in the upper layers above the earth; all the bending is over by the time the surface is reached. It is difficult to see how an ethereal drift will not tend to cause an aberration in the wrong direction.

Of the experiments hitherto made by Arago, Babinet, Maxwell, Mascart, Hoek, and perhaps others, though all necessary to be tried, not one really discriminates between the rival hypotheses. All are consistent either with absolute quiescence of ether near moving bodies, or with relative quiescence near the earth's surface. They may be said, perhaps, to be inconsistent with any intermediate position.

Two others, however, do appear to discriminate, viz. an old and difficult polarization experiment of Fizeau (*Ann. de Chim. et de Phys.*, 1859), which has not been repeated since, and the recent famous experiment of Michelson (*Phil. Mag.*, 1887) with rays made to interfere after traversing and retraversing paths at right angles.

The conclusions deducible from these two experiments are antagonistic. Fizeau's appears to uphold absolute rest of ether; Michelson's upholds relative rest, *i.e.* drag by the earth.

The author now attempts a direct experiment as to the effect of moving matter on the velocity of light in its neighbourhood; assuming that a positive or negative result with regard to the effect of motion on the velocity of light will be accepted as equivalent to a positive or negative result with respect to the motion of the ether.

He gives a detailed account of the experiment, the result of which is to show that such a mass as a pair of circular saws clamped together does not whirl the ether between the plates to any appreciable amount, not so much, for instance, as a 1/500th part of their speed. He concludes, therefore, that the ether is not appreciably viscous. But, nevertheless, it may perhaps be argued that enormous masses may act upon it gravitationally, straining it so as perhaps to produce the same sort of effect as if they dragged it with them. He proposes to try the effect of a larger mass. Also to see if, when subject to a strong magnetic field, ether can be dragged by matter.

The aberrational effect of slabs of moving transparent matter is considered, also the effect of a differently refractive medium.

Motion of medium, though incompetent to produce any aberrational or Doppler effect, is shown to be able to slightly modify them if otherwise produced.

The Doppler effect is then entered into. The question is discussed as to what the deviation produced by a prism or a grating really depends on: whether on frequency or wave-length. It is shown that whereas the effect of a grating must be independent of its motion and depend on wave-length alone, yet that the effect observed with a moving grating by a moving observer depends on frequency, because the motion of the observer superposes an aberrational effect on the true effect of the grating. This suggests a means of discriminating motion of source from motion of observer; in other words, of detecting absolute motion through ether; but the smallness of the difference is not hopeful.

Michelson's experiment is then discussed in detail, as a case of normal reflection from a moving mirror or from a mirror in a drifting medium. No error in its theory is discovered.

The subjects of change of phase, of energy, of reflection in a moving medium, work done on a moving mirror, and the laws of reflection and refraction as modified by motion, are considered.

It is found that the law of reflection is not really obeyed in a relatively moving medium, though to an observer stationary with respect to the mirror it appears to be obeyed, so far as the first order of aberration magnitude is concerned; but that there is a residual discrepancy involving even powers of aberration magnitude, of an amount possibly capable of being detected by very delicate observation.

The following statements are made and justified:—

(1) The planes of incidence and reflection are always the same.

(2) The angles of incidence and reflection, measured between ray and normal to surface, usually differ.

(3) If the mirror is stationary and medium moving, they differ by a quantity depending on the square of aberration magnitude, *i.e.* by 1 part in 100,000,000; and a stationary telescope, if delicate enough, might show the effect.

(4) If the medium is moving and mirror stationary, the angles differ by a quantity depending on the first power of aberration magnitude (1 part in 10,000), but a telescope moving with the mirror will not be able to observe it; for the commonplace aberration caused by motion of receiver will obliterate the odd powers and leave only the even ones; the same as in case (3).

(5) As regards the angles which the incident and reflected waves make with the surface, they differ in case (3) by a first order magnitude, in case (4) by a second order magnitude.

(6) At grazing incidence the ordinary laws are accurately obeyed. At normal incidence the error is a maximum.

(7) The ordinary laws are obeyed when the direction of drift is either tangential or normal to the mirror, and is disobeyed most when the drift is at 45°.

(8) In general, the shape of the incident wave is not precisely preserved after reflection in a moving medium. To a parallel beam the mirror acts as if slightly tilted; to a conical beam as if slightly curved. But either effect, as observable in the result, is almost hopelessly small.

(9) Similar statements are true for refraction, assuming Fresnel's law.

The possibility of obtaining first order effects from general ethereal motion by means of electrical observations is considered.

**Chemical Society, March 17.**—Dr. W. J. Russell, F.R.S. Vice-President, in the chair.—The following papers were read:—A study of the conditions which determine combination between the cyanides of zinc and mercury, and of the composition and properties of the resulting double salt, by W. R. Dunstan. When a solution of zinc sulphate is added to one of mercuric potassium cyanide,  $HgK_2(CN)_4$ , or when mercuric chloride is added to a solution of zinc potassium cyanide,  $ZnK_2(CN)_4$ , a white precipitate is formed, which has been stated, on the authority of Gmelin, to consist of a double cyanide of zinc and mercury of the formula  $ZnHg(CN)_4$ . This, however, is not the case. The maximum amount of mercuric cyanide that can be retained by the precipitate is only 38.5 per cent., and is dependent on the amount of water present during precipitation as well as on the proportions in which the salts interact. When



washed with cold water the precipitate loses a large proportion, though not all, of the mercuric cyanide contained in it. Boiling water and cold potassium iodide solution extract the mercuric cyanide more readily. Experiments have been made in which the relative masses of the interacting substances were varied, these experiments prove that a true compound of the two cyanides is formed, and suffers decomposition to a greater or less extent, depending on the amount of water present. An examination of the curves plotted from these results leads to the inference that the double salt is a tetrazincic monomercuridecyanide,  $Zn_4Hg(CN)_{10}$ .—A lecture experiment to illustrate the phenomena of coal-dust explosions, by T. E. Thorpe. The author describes an apparatus by means of which the phenomena of a coal-dust explosion, resulting either from a local explosion of fire-damp or by the direct action of a blown-out shot, may be illustrated. The apparatus consists of a long narrow wooden box having an explosion chamber at one end; a thin layer of fine coal-dust or lycopodium powder is spread along the bottom of the box. On firing a mixture of coal-gas and air in the explosion chamber, the explosive wave sweeps along the box with increasing strength until it shoots out at the open end of the apparatus. By observations made with this apparatus the author finds that there is no evidence of a diminution of pressure along the sides of the space through which the flame rushes, and he is of opinion that there is no experimental proof of the validity of the "suction theory," which assumes that in consequence of this alleged diminution of pressure, occluded fire-damp is drawn out from the coal, and contributes to the violence of the explosion.—The production of the ketone, 1:2:4 acetylorthoxylene from camphor by the action of sulphuric acid and zinc chloride, by H. E. Armstrong and F. S. Kipping. The authors have previously stated that they have separated a ketone of the composition  $C_9H_{12}O$  from the crude product of the action of sulphuric acid on camphor. On treatment with bromine the ketone yields a compound which readily decomposes, giving a monobromo-derivative,  $C_9H_{11}BrO$ , melting at  $63^\circ-64^\circ$ . When oxidized with dilute nitric acid, the ketone yields two acids, separable by means of chloroform. One of these proves to be paraxylic acid, viz. 1:2:4 dimethylbenzoic acid, whilst the other is xylinic or 1:2:4 methylphthalic acid. The ketone is therefore 1:2:4 acetylorthoxylene, a compound which Claus has synthesized from acetic chloride and orthoxylene in presence of aluminium chloride.—Platinum tetrachloride, by W. Pullinger. The author has obtained platinum tetrachloride by heating hydrated hydrogen platinum chloride in a current of dry hydrogen chloride at  $163^\circ$  for fifteen hours. When thus prepared, it is a very soluble, but not deliquescent, substance.—Note on a new acid from camphoric acid, by W. H. Perkin, Jun. When warmed with sulphuric acid, camphoric acid is converted into sulphocamphoric acid, with loss of water and carbon monoxide,  $C_{10}H_{16}O_4 + H_2SO_4 = C_9H_{16}SO_3 + CO + H_2O$ . Kachler found that, when fused with potash, sulphocamphoric acid yields a crystalline substance,  $C_9H_{12}O_2$ , melting at  $148^\circ$ , which is apparently not an acid. The author in repeating Kachler's experiments, but sulphoning at  $100^\circ$  instead of at  $65^\circ$ , obtained a well-characterized monobasic acid,  $C_9H_{12}O_2$ , isomeric with this substance and melting at  $108^\circ$ . It would appear from these results that the acid obtained by sulphoning camphoric acid at  $100^\circ$  is isomeric with ordinary sulphocamphoric acid.—The specific rotatory and cupric reducing power of invert sugar and of dextrose obtained from cane sugar by means of invertase, by J. O'Sullivan. The author describes experiments in which the hydrolysis of cane sugar was effected by means of invertase instead of by means of acid. The specific rotatory power of invert sugar obtained by means of invertase, which has no action on levulose, is  $[\alpha]_D = -24^\circ 5'$ , and that of the dextrose prepared from such invert sugar is  $[\alpha]_D = 57^\circ$ . The apparent specific rotatory power of levulose calculated from these numbers is  $[\alpha]_D = -106^\circ$ , or  $[\alpha]_D = -93^\circ 8'$ , a value agreeing with that generally accepted.—Ethylidimethylamidobenzene, by W. R. Hodgkinson and L. Limpach. This amine is prepared by heating paraxylylene hydrochloride with ethyl alcohol at  $250^\circ-300^\circ$ . It is purified from diethyldimethylamidobenzene by crystallization of the sulphates. The sulphate of the latter substance is the more soluble. The formyl and acetyl derivatives of the amine are described.—Action of nitric acid on oxanilide and its analogues, by A. G. Perkin. The author finds that oxanilide and its analogues are readily converted by nitration into the higher nitro-derivatives, thus differing from acetanilide and similar compounds, which yield dinitro-derivatives only with great difficulty.

Royal Meteorological Society, March 16.—Dr. C. Theodore Williams, the President, delivered an address on the value of meteorological instruments in the selection of health resorts. He drew attention to thermometers, maximum and minimum, as the foundation-stone on which medical climatology rests, and instanced effects of extreme cold or of heat on the human organism. The direct rays of the sun are of the greatest importance, and in health resorts should be utilized to the full—in fact, only climates where during the winter months even a delicate person can lie or sit for several hours a day basking in the sunshine are to be recommended for most complaints, and the various forms of sunshine-recorders are used to aid the medical adviser in the choice of such health stations. After referring to the value of rain-gauges, hygrometers, and barometers, Dr. Williams stated that many health resorts owe their reputation almost solely to their shelter from cold winds; for instance, the advantage in climate which Hyères and Mentone enjoy over Marseilles is chiefly due to their being more sheltered from the Mistral, or north-west wind, the scourge of the lower valley of the Rhone from Valence to Avignon. He went on to describe the climate of the Riviera, illustrating it by lantern slides from recent photographs, including views of Hyères, Costabelle, Cannes, Nice, Mentone, San Remo, &c., and he showed the three principal causes of the warm winter of this region to be (1) the southern latitude, (2) the protection from cold winds by mountain ranges, and (3) the equalizing and warming influence of the Mediterranean Sea, which, being practically tideless, is always equally potent, not varying with hour and season. Dr. Williams mentioned the weak points of the south of France climate, with its blustering Mistral, its occasional cold Bise, its moist Scirocco wind; but summed up the Riviera winter climate as being, as a whole, clear, bright, and dry, with fog and mist practically unknown, with a winter temperature from  $8^\circ$  to  $10^\circ$  higher than England though subject to considerable nocturnal radiation, with about half the number of rainy days, and four or five times the number of bright ones, which we can boast of, with cold winds and cold weather, without which it would lose its health-giving effect.—After the delivery of this address the meeting was adjourned in order to allow the Fellows and their friends an opportunity to inspect the Exhibition of Instruments relating to climatology, which had been arranged in the rooms of the Institution of Civil Engineers, 25 Great George Street. The Meteorological Office showed a set of instruments necessary for the equipment of a climatological station, viz. Stevenson thermometer screen, fitted with dry bulb, wet bulb, maximum and minimum thermometers, and also a rain gauge. Thermometers were also shown for ascertaining the temperature on the ground, under the ground, and at a distance, as well as for recording temperature continuously. Various forms of sunshine-recorders were exhibited, as well as a number of actinometers and solar radiation instruments for ascertaining the heating effect of the solar rays. The Exhibition included a large and interesting collection of hygrometers, also several rain-gauges and other instruments. Among the curiosities was a piece of plate glass, which was "starred" during a thunderstorm on August 21, 1879; this was not broken, but it has a number of wavy hair-like lines. The Exhibition contained a large number of beautiful photographs of clouds, lightning, and snow scenes, as well as of the damage done by the destructive tornado at Lawrence, Mass., U.S.A. The Exhibition remained open until Tuesday, the 22nd ult.

Anthropological Institute, March 22.—Francis Galton, F.R.S., Vice-President, in the chair.—Mr. Theodore Bent read a paper on the finds at the Great Zimbabwe ruins. The outer wall of the semicircular temple on the hill is decorated by a number of birds perched on long soapstone pedestals, all of which appear to be intended to represent the same bird, probably a vulture. Two of the birds, similar in character and slightly varying from the others, are represented as perched on zones or cesti, and there seems to be a similar class of symbolism connecting them all. Mr. Bent is of opinion that these birds represent the Assyrian Astarte or Venus—the female element in creation. In the centre of the temple stood an altar, into the stones of which were inserted a large number of soapstone objects, which afforded ample evidence of the existence of phallic worship in this place. Within the sacred inclosure are two solid round towers, the largest of which is 34 feet in height and has a girth of 53 feet. Before them is a raised platform, presumably for sacrifice, and the wall behind them is decorated

with large standing monoliths. Some of the fragments of pottery found are very good, and give evidence of a highly developed artistic skill. Close underneath the temple stood a gold-smelting furnace, made of very hard cement of powdered granite, with a chimney of the same material, and the quantity of rejected quartz found hard by proved that these ruins had formed the fortress for the protection of a gold-producing people. The ruins and the things in them are not in any way connected with any known African race; the objects of art and of special cult are foreign altogether to the country, and neither the date of construction nor the race of the builders can now be determined with accuracy; but the evidence in favour of this race being one of the many tribes of Arabia is very strong, and all the facts point to a remote antiquity.

## PARIS.

**Academy of Sciences, March 28.**—M. d'Abbadie in the chair.—Note on a theorem on the calculation of probabilities, by M. J. Bertrand.—On the periodic variations of latitude, according to a letter from M. Helmerl to the members of the Permanent Commission of the International Geodetic Association, by M. Faye. (See Our Astronomical Column.)—On the approximate theoretical calculation of the delivery from an orifice in a thin wall, by M. J. Boussinesq.—On the population of the five continents of the earth, by M. Émile Levasseur. A comparison of M. Levasseur's estimations with those given by others shows that the differences are greater for Africa, Asia, Oceania, and America, than for Europe. This is what would be expected. M. Levasseur's numbers are as follows:—

	Area, in millions of square kilometres.	Population, in millions.
Europe ... ..	10 <sup>0</sup>	360
Africa ... ..	30 <sup>5</sup>	153
Asia ... ..	42 <sup>2</sup>	824
Oceania ... ..	11 <sup>1</sup>	38
North America ... ..	23 <sup>7</sup>	88
South America ... ..	18 <sup>7</sup>	34
Total ... ..	136 <sup>2</sup>	1497

—Note on a theory on the production of various vegetable galls, by M. A. Laboulbène.—Mechanical laws of atmospheric circulation; surfaces of equal density; squalls; secondary and general circulations, by M. Le Goarant de Tromelin.—Observations of Swift's comet (Rochester, March 6<sup>th</sup> 1892) and of the minor planet discovered by Wolf on March 18, made with the East Tower equatorial of Paris Observatory, by Mdlle. D. Klumpke. Observations for position were made on March 17, 21, 23, and 24.—Observations of Swift's comet made at Toulouse Observatory, by M. B. Baillaud. Observations for position were made on March 16, 18, 19, 21, and 25.—Observations of Wolf's periodic comet made with the great telescope of Toulouse Observatory, by MM. E. Cosserrat and F. Rossard. Dates of observations for position: November 28, December 1, 4, 21, 22, 26, and 31.—On plane *isobars* having equal invariants, by M. G. Kenigs.—On congruences of which the mean surface is a plane, by M. C. Guichard.—On the existence of integrals in differential systems, by M. Riquier.—An electro-ballistic chronograph, by M. W. Schmidt.—On the radiations of incandescent bodies and the optical measure of high temperatures, by M. J. Violle. By estimating the intensities of the lines at C and D in the radiations of a piece of platinum, the author has determined the temperature of the metal. His results agree very well with those obtained by M. Le Chatelier up to 1500°.—On the temperature of the sun, by M. H. Le Chatelier. (See Our Astronomical Column.)—Application of the theory of lines of force to the demonstration of an electrostatic theorem, by M. L. de la Rive.—On electro-capillary phenomena, by M. A. Berget.—On a safety-lamp for use with coal gas, by M. F. Parmentier. The author records some experiments on the action of platinum wires and crucibles in cooling flames below the temperature necessary for the combustion of the gases.—Action of potassium fluoride on anhydrous chlorides; preparation of anhydrous fluorides of nickel and potassium, and of cobalt and potassium, by M. C. Pouleuc. The compounds prepared have the composition NiKF<sub>3</sub> and CoKF<sub>3</sub>. Full descriptions are given of the mode of preparation and the properties of the new substances.—On the fixation of iodine by starch, by M. G. Rouvier.—On the estimation of fluorine, by M.

Ad. Carnot.—On the aldehydes and acetone bromides which result from the action of bromine on alcohols of the fatty group, by M. A. Etard.—On propylamines and some of their derivatives, by M. F. Chancel.—On some reactions of isomeric amido-benzoic acids, by M. Oechsner de Coninck.—Study of the velocity of decomposition of diazo-compounds, by MM. J. Hausser and P. Th. Muller.—On two fluohydrines of glycerine, by M. Maurice Meslans. (See Notes.)—On the mode of union of rings of the abdomen (*zigzag* articulation) of Hymenoptera, by M. G. Carlet.—On the embryonic development of the Galathea of the genus *Diptychus*, by M. E. L. Bouvier.—On the histology of the pituitary gland, by M. G. Saint-Remy.—On the blue colouring matter in the blood of Crustacea, by M. F. Heim.—On a new marine Rhizopod (*Pontomyxa flava*, g. et sp. n.), by M. E. Topsent.—The streptonyr nervous system of Heteropods, by M. Paul Pelseener.—Observations on *Panthracosoma macule*, by M. Louis Mangin.—On the artificial culture of Diatomaceae, by M. P. Miquel.—On the crystalline rocks of Chablais, by M. Michel-Lévy.—The Saint-Béat marble, its age and stratigraphical relations, by M. Caralp.—On some minimum perceptible quantities of certain odours, by M. Jacques Passy.—Difference in the functions exercised on the bladder by the afferent nerves of the hypogastric plexus, by M. Lannegrace.—On the Martinique cyclone of August 18, 1891, by M. G. Landes.—Magnetic disturbances and seismic phenomena, by M. Émile Rivière.

## BOOKS and PAMPHLETS RECEIVED.

BOOKS.—Index of Meteorological Observations in the United States (Washington).—Essex Institute Historical Collections, vol. xxvii. (Salem, Mass.)—A New Course of Experimental Chemistry: J. Castell-Evans (Murbly).—Souvenir of Shakespeare's King Henry the Eighth (*Black and White*).—Deutsches Meteorologisches Jahrbuch für 1892 (Hamburg).—Island Life, and edition: A. R. Wallace (Macmillan).—A Naturalist in the Transvaal: W. L. Distant (Porter).—The Clyde Sea Area: Dr. H. R. Mill (Williams and Norgate).—Live Stock: Prof. J. Wrightson (Cassell).—The Great Earthquake in Japan, 1891: J. Milne and W. K. Burton (Stanford).

PAMPHLETS.—Azimut Assoluto del Segnale Trigonometrico di Monte Vesco sull' orizzonte di Torino: F. Porro (Torino).—Ergebnisse der Meteorologischen Beobachtungen im Systeme der Deutsche Seewarte für das Lustrum 1886-90 (Hamburg).

## CONTENTS.

	PAGE
Mendeléeff's Principles of Chemistry. By T. E. T.	529
The Ligation of the Great Arteries. By Dr. M. Armand Ruffer	530
Our Book Shelf:—	
Streeter: "Precious Stones and Gems: their History, Sources, and Characteristics"	531
Lewes: "Air and Water"	531
Letters to the Editor:—	
Ornithology of the Sandwich Isles.—Prof. Alfred Newton, F.R.S.; J. E. Harting	532
Poincaré's Thermodynamics.—P. G. T.	532
M. Poincaré and Maxwell.—Prof. Geo. Fras. Fitzgerald, F.R.S.	532
Prof. Burnside's Paper on the Partition of Energy, R.S.E., July 1887.—Prof. W. Burnside; S. H. Burbury, F.R.S.	533
Double Orange.—Gerald E. Francis	534
Metals at High Temperatures. ( <i>Illustrated</i> ). By Prof. W. C. Roberts-Austen, C.B., F.R.S.	534
On Insect Colours. II. By F. H. Perry Coste	541
Examination of the Standards of Measure and Weight immured in the Houses of Parliament	543
Notes	543
Our Astronomical Column:—	
The Relative Motion of 61 Cygni	547
The Temperature of the Sun	547
Comet Swift, March 6	538
Wolf's Comet, 1891 II.	531
Periodic Perturbations of the Four Inner Planets	548
N.P.D.'s observed with Greenwich and Washington Transit Circles	54
Washington Observations, 1887	54
Fertilization of the Casuarinacæ. By A. W. B.	548
University and Educational Intelligence	549
Societies and Academies	549
Books and Pamphlets Received	552

THURSDAY, APRIL 14, 1892.

A REMARKABLE BOOK ON THE HABITS  
OF ANIMALS.

*The Naturalist in La Plata.* By W. H. Hudson, C.Z.M.S. With Illustrations. (London: Chapman and Hall, Ltd., 1892.)

THIS volume deserved a more distinctive title, since it differs widely from the several works of other naturalists with which it may be classed judging from the title-page alone. It is, in fact, so far as the present writer knows, altogether unique among books on natural history. It is to be hoped that its success will be proportional to its merits, and that it will form the first of a series of volumes, by means of which residents in the various extra-European countries will make known to us the habits of the animals which surround them. What renders this work of such extreme value and interest is, that it is not written by a traveller or a mere temporary resident, but by one born in the country, to whom its various tribes of beasts, birds, and insects have been familiar from childhood; who is imbued with love and admiration for every form of life; and who for twenty years has observed carefully and recorded accurately everything of interest in the life-histories of the various species with which he has become acquainted. When we add to this the fact that the writer of this volume is well acquainted with the literature, both old and new, bearing upon his subject; that he groups his facts and observations so as to throw light on obscure problems, and often adduces evidence calculated to decide them; and, in addition to all this, that the book is written in an earnest spirit and in a clear and delightful style, it becomes evident that not all who attempt to follow in his steps can hope to equal their forerunner.

As every chapter of the book contains new and interesting matter, it is difficult to convey an adequate idea of it by partial extracts or by an enumeration of its chief topics; but the attempt must be made. The first chapter gives us a general sketch of the "Desert Pampas" and its forms of animal life. The viscacha, the coypu, and the tucu-tucu—three strange rodents—are brought vividly before us by a description of some of their more prominent habits; the edentate armadilloes appear in a new light, since one of them, the hairy armadillo, is shown to be a dominant species holding its own against enemies of higher type, so omnivorous that it can live on almost everything from grass to flesh, the latter either found dead and in all stages of decay or captured by means of its own strategy. It is so agile that it catches mice, so strong and well armed that it kills poisonous snakes, and having killed them cuts them in pieces and swallows as much as it needs. Mr. Hudson adds:—

"It is much hunted for its flesh, dogs being trained for the purpose; yet it actually becomes more abundant as population increases in any district; and, if versatility in habits or adaptiveness can be taken as a measure of intelligence, this poor armadillo, a survival of the past, so old on the earth as to have existed contemporaneously with the giant glyptodon, is the superior of the large-brained cats and canines."

Equally extraordinary are the still lower opossums, one of which is semi-aquatic and apparently adapted to its surroundings, while the other species (*Didelphys azarae*) is in every way adapted to an arboreal life, yet it is everywhere found in this level treeless district, which leads to one of our author's suggestive remarks:—

"For how many thousands of years has this marsupial been a dweller on the plain, all its best faculties unexercised, its beautiful grasping hands pressed to the ground, and its prehensile tail dragged like an idle rope behind it! Yet, if one is brought to a tree, it will take to it as readily as a duck to water, or an armadillo to earth, climbing up the trunk and about the branches with a monkey-like agility. How reluctant Nature seems in some cases to undo her own work! How long she will allow a specialized organ, with the correlated instinct, to rest without use, yet ready to flash forth on the instant, bright and keen-edged, as in the ancient days of strife, ages past, before peace came to dwell on earth!"

But we must pass on from this mere preliminary chapter to more solid matter, only noting that we have a vivid sketch of the great rhea or American ostrich, of the flamingo, the swans, and the noble crested screamer, all of which are being exterminated by increasing population and improved weapons; and this leads to a noble protest against this extermination, of which we can only quote the concluding words:—

"Only when this sporting rage has spent itself, when there are no longer any animals of the larger kinds remaining, the loss we are now inflicting on this our heritage, in which we have a life-interest only, will be rightly appreciated. It is hardly to be supposed or hoped that posterity will feel satisfied with our monographs of extinct species, and the few crumbling bones and faded feathers which may possibly survive half-a-dozen centuries in some happily-placed Museum. On the contrary, such dreary mementoes will only serve to remind them of their loss; and if they remember us at all, it will only be to hate our memory, and our age—this enlightened, scientific, humanitarian age, which should have for its motto, 'Let us slay all noble and beautiful things, for to-morrow we die.'"

A chapter devoted to the puma is full of new and interesting matter. This animal ranges from British Columbia to the Straits of Magellan, but throughout this vast region there seems to be no authentic record of its ever attacking men except in self-defence. This has led to its being thought to be cowardly, whereas it is one of the bravest of the feline race, since it constantly attacks and conquers the jaguar whenever the two inhabit the same district, while in North California it is the enemy of the grizzly bear, and is again always the victor. In the Pampas, where it is common, the fact that it never attacks man, in however helpless a position he may be, is so well known, that the Gaucho confidently sleeps on the ground, although he knows that pumas are close by; while it is said that a child may sleep on the plain unprotected in equal security. Many curious anecdotes are given in illustration of this remarkable trait of so powerful and, as regards all other large Mammalia, blood-thirsty a creature. And the curious thing is that it seems to be no dread or dislike of man that leads to the peculiarity, but rather some strange feeling of affection, or sense of pleasure in man's vicinity, shown in many curious ways, which has led the Pampas-dwelling Gauchos to call it "the friend of man."

In the next chapter, entitled "A Wave of Life," we have a far broader subject touched upon and illustrated by a mass of curious observations. The interdependence and complex relations of species, so admirably portrayed by Darwin, are here brought vividly before us. We are told how, during a fine moist summer, when grass and flowers were abundant, mice increased to an abnormal extent, so that everywhere in the fields it was difficult to avoid treading on them, while dozens could be shaken out of every hollow thistle-stalk lying on the ground. The most incongruous animals swarmed to the feast which they provided. Dogs lived almost entirely on them, as did the domestic fowls, assuming the habits of rapacious birds. The cats all left the houses to live in the fields. Tyrant-birds and cuckoos seemed to prey on nothing else. Foxes, weasels, and opossums fared sumptuously, and even the common armadillo turned mouser with great success. Storks and short-eared owls gathered to the feast, so that fifty of the latter birds could often be seen at once, and they got fat and bred in the middle of winter, quite out of their proper season, in consequence. The following winter was a time of drought, the grass and herbage had all been consumed or was burnt up, and the mice, having no shelter, and being obliged to search for food, soon fell a prey to their numerous enemies, and were almost wholly exterminated. Their vast increase, by bringing together innumerable enemies, was the cause of their succeeding decrease. As Mr. Hudson well remarks:—

"Here, scene after scene in one of Nature's silent, passionless tragedies opens before us, countless myriads of highly-organized beings rising into existence only to perish almost immediately, scarcely a hard-pressed remnant remaining after the great reaction to continue the species."

We cannot stop to notice a tith of the curiosities of natural history with which this volume abounds, such as the poisonous toad which kills horses, and the wrestler frog, which gives a sudden pinch to an enemy with its muscular fore-legs, and then escapes; the huge venomous man-chasing spider, a species of *Lycosa*, which actually pursues men on foot and on horseback; the strange dread which gnats, mosquitoes, and sand-flies have of dragon-flies, so that a single individual of the latter insect will cause clouds of the tormentors instantly to disappear; the interesting discussion on parasite problems, and the wonderful storms of dragon-flies which *precede* wind-storms from the interior; the new and interesting cases of mimicry and of warning colours; and the delightful chapter on the crested screamer, the author's prime favourite among all the denizens of the Pampas, which, though possessing a body as large as that of a swan, yet soars up into the air like a lark, and in flocks of thousands, when so high as to appear only specks in the blue sky, pours forth its song in silvery sounds delightful to listen to. These and many other matters of interest must be studied in the book itself, since we must devote the remainder of our limited space to some valuable observations and discussions on certain instincts, by which new light is thrown on several disputed questions.

The chapter on "Fear in Birds" is especially interesting, since the result of the author's observations is opposed to the view held by Darwin and Herbert Spencer as to their

instinctive fear of man or birds of prey antecedent to experience or parental teaching. The one thing that is instinctive is the alarm caused by the warning note of the parent. This produces an effect even before the chick is hatched, for, in three different species belonging to widely separated orders, Mr. Hudson has watched the nest while a young bird was chipping its way out of the egg and uttering its feeble *peep*, when, on hearing the warning cry of the mother-bird, both sounds instantly cease, and the chick remains quiescent in the shell for a long time, or till the parent's changed note shows that the danger is over. Young nestling birds take their food as readily from man as from their parents, till they hear the warning cry, when they immediately close their mouths, and crouch down frightened in the nest. Parasitical birds which do not recognize the warning cries of their foster-parents show no fear. The young parasitical cow-bird takes food from man, and exhibits no fear although the foster-parents are hovering close by screaming their alarm notes. So, a young wild dove, reared from the egg by domestic pigeons which, never being fed, were half wild in their habits, never acquired the wildness of its foster-parents, but became perfectly tame and showed no more fear of a man than of a horse. He had none of his own kind to learn from, and did not understand either the voices or the actions of the dove-cot pigeons. Mr. Hudson has also reared plovers, tinamous, coots, and many other wild birds from eggs hatched by fowls, and found them all quite incapable of distinguishing friend from foe, while some, such as the rhea and the crested screamer, are much tamer when young than domestic chickens and ducklings.

Mr. Hudson concludes that birds learn to distinguish their enemies, first from parental warnings and later by personal experience, and he considers that this view is confirmed by the different behaviour of birds in the presence of various species of the hawk tribe, the amount of alarm shown being exactly proportionate to the degree of danger. Some hawks never attack birds, others only occasionally. The chimango kite is chiefly a carrion-feeder, and its presence excites no alarm among small birds. One of the harriers is so like the chimango in some states of plumage that the latter is sometimes mistaken for it, and a certain amount of fear is exhibited, which, however, soon passes away on discovering the real nature of the intruder. Buzzards are still more feared than harriers, as they are more destructive to birds, and they cause a somewhat greater amount of alarm. But most dangerous of all is the peregrine falcon, and, however high in the air this may be, the feathered world is thrown into the greatest commotion, all birds, from the smallest up to species as large as duck, ibis, and curlew, rushing about as if distracted. Even when the falcon has disappeared, the wave of terror excited by it subsides but slowly, and the birds continue for a considerable time to be wild and excited. Now, this nicely-measured alarm, proportioned to the danger to be apprehended from the different species, can hardly be due to inherited instinct, even if this could explain the general dread of raptorial birds; and, taken in connection with the numerous other facts in the habits of young birds, leads to the conclusion that fear of enemies is wholly the result of education and experience.

Perhaps the most interesting chapter in the whole volume, the fullest in new matter, and the most important in its bearing on a much-disputed theory, is that on "Music and Dancing in Nature." The result of Mr. Hudson's long-continued observations is that almost all mammals and birds have the habit of indulging occasionally in more or less regular performances, with or without sound, or composed of sound only, some being only discordant cries and choruses or uncouth irregular motions, while the more aerial, graceful, and melodious kinds exhibit more complex and more beautiful forms. It is among birds that this habit is most fully developed and presents itself in the most graceful or fantastic performances. Great numbers of birds of very different forms and habits—hawks, vultures, ibises, spoonbills, and gulls—circle about in the air, singly or in flocks, and apparently for the mere delight in aerial motion. Sometimes they rise to vast altitudes, and float about in the air in one spot for an hour or longer at a time, hundreds of birds gliding in and out among each other with perfect precision as in a set dance. Ibises and ducks have special performances of their own, but perhaps the most curious are those of some species of rails. The ypecaha rails have meeting-places on smooth level ground near the water and well surrounded by dense beds of rushes. One bird sounds a note of invitation; others from all sides come hurriedly to the place, where they begin a strange screaming concert, rushing about all the time. The cries they utter somewhat resemble human screams of terror, frenzy, or despair, mingled with half-smothered cries of pain and moans of anguish. This exhibition lasts a few minutes, after which the assembly peacefully breaks up.

The singular wattled, wing-spurred, and long-toed jacanas have a different kind of meeting. They usually go singly or in pairs; but occasionally, in response to a call by one of them, all who are within hearing leave off feeding and fly to one spot, where they walk about with their beautiful wings erect or half open, or waved up and down with a slow and measured motion. With these two species both sexes join in the display; but that of the spur-winged lapwing is altogether peculiar, inasmuch as it takes place with three individuals only. These birds live in pairs, and at intervals during the day or on moonlight nights, one bird will leave his mate and fly to another pair a short distance off. These will receive the visitor with signs of pleasure. First going to meet him, they place themselves behind him, and all three march rapidly, uttering special notes. Then they stop; the leader stands erect with elevated wings uttering loud notes, while the other two, with puffed-out plumage, standing side by side, stoop forward till the tips of their beaks touch the ground, and with a low murmuring sound remain for some moments in this strange posture. Then the visitor goes back to his own ground and mate, and later on they receive a visitor, whom they treat in the same ceremonious fashion. They are said to be so fond of this form of visiting that they indulge in it all the year round, and the illustration representing it is a most curious and fantastic picture of bird life.

A considerable number of Passerine birds also have curious displays, which are here described, as well as songs of a most remarkable character. Some sing alone,

others in concert; in most instances the voice is at its best during the mating period, but in one of the smaller finches the song is at that time feeble, while at a later period it becomes far more powerful and melodious. There is one species, the white-banded mocking-bird, which is considered to exceed all other songsters in the copiousness, variety, and brilliant character of its music. By the half-hour it will first imitate with great accuracy the songs of many other species—a strange and beautiful performance; but this is merely the prelude to its own song, which is "uttered with a power, abandon, and joyousness resembling, but greatly exceeding, that of the skylark singing 'at Heaven's gate'; the note issuing in a continuous torrent; the voice so brilliant and infinitely varied that, if rivalry and emulation have as large a place in feathered breasts as some imagine, all that hear this surpassing melody might well languish ever after in silent despair."

Mr. Hudson's conclusion as to the meaning of the various actions and vocal performances that he describes, and of which only a few cases have been here referred to, is as follows:—

"I wish now to put this question: What relation that we can see or imagine to the passion of love and the business of courtship have these dancing and vocal performances in nine cases out of ten? In such cases, for instance, as that of the scissors-tail tyrant-bird, and its pyrotechnic evening displays, when a number of couples leave their nests, containing eggs and young, to join in a wild aerial dance; the mad exhibitions of ypecahas and ibises, and the jacanas' beautiful display of grouped wings; the triplet dances of the spur-winged lapwing, to perform which two birds already mated are compelled to call in a third bird to complete the set; the harmonious duets of the oven-birds, and the duets and choruses of nearly all the wood-hewers, and the wing-slapping aerial displays of the whistling widgeons; will it be seriously contended that the female of this species makes choice of the male able to administer the most vigorous and artistic slaps? . . . There are many species in which the male, singly or with others, practises antics or sings during the love-season before the female; and when all such cases, or rather those which are most striking and *bizarre*, are brought together, and when it is gratuitously asserted that the females *do* choose the males that show off in the best manner or that sing best, a case for sexual selection seems to be made out. How unfair the argument is, based on these carefully selected cases gathered from all regions of the globe, and often not properly reported, is seen when we turn from the book to Nature, and closely consider the habits and actions of all the species inhabiting any one district. We see then that such cases as those described and made so much of in the 'Descent of Man,' and cases like those mentioned in this chapter, are not essentially different in character, but are manifestations of one instinct, which appears to be almost universal among the higher animals. The explanation I have to offer lies very much on the surface. . . . We see that the inferior animals, when the conditions of life are favourable, are subject to periodical fits of gladness, affecting them powerfully, and standing out in vivid contrast to their ordinary temper. And we know what this feeling is—this periodic intense elation which even civilized man occasionally experiences when in perfect health, more especially when young. There are moments when he is mad with joy, when he cannot keep still, when his impulse is to sing and shout aloud and laugh at nothing, to run and leap and exert himself in some extravagant way."

And after showing how this impulse of joy is manifested in different animals according to their peculiarities of structure and habit, and after giving a number of other illustrative cases, he thus concludes:—

“I am convinced that any student of the subject who will cast aside his books, and go directly to Nature to note the actions of animals for himself—actions which, in many cases, appear to lose all significance when set down in writing—the result of such independent investigation will be a conviction that conscious sexual selection on the part of the female is not the cause of music and dancing performances in birds, nor of the brighter colours and ornaments that distinguish the male.”

Other chapters of almost equal interest are those on the habit of the huanaco to go to certain places to die, and on the strange instincts of cattle, such as the excitement caused by the sight and smell of blood, that produced by scarlet clothing, and the persecution of the sick and weakly of the herd. These subjects are discussed with a fulness and originality the result of long personal observation, and will command the careful attention of those who are interested in the mental phenomena presented by animals. It remains only to add that the book is beautifully got up, that the text is singularly free from misprints, and that the numerous illustrations—photographic reproductions of drawings—are at once delicate and characteristic. Never has the present writer derived so much pleasure and instruction from a book on the habits and instincts of animals. He feels sure that it will long continue to be a storehouse of facts and observations of the greatest value to the philosophical naturalist, while to the general reader it will rank as the most interesting and delightful of modern books on natural history.

ALFRED R. WALLACE.

#### THE PREVENTION OF INFLUENZA.

*A Study of Influenza, and the Laws of England concerning Infectious Diseases, &c.* By Richard Sisley, M.D.Lond., M.R.C.P.Lond. (London: Longmans, Green, and Co., 1892.)

UNDER the above title Dr. Sisley has collected papers read by him during the past twelve months before the Society of Medical Officers of Health, the Epidemiological Society, and the Congress of Hygiene. To these are appended extracts from the different Acts bearing on infectious disease, the provisional memorandum on epidemic influenza just issued by the Local Government Board, and sundry other matters connected with the subject. The work makes no pretence to be a study of influenza from the clinical or pathological standpoint; it deals simply with the prevention of the disease in epidemic form, and the legal machinery at our command for that purpose.

It may, at first sight, seem strange that, when, during the latter part of 1889, we watched the epidemic wave sweeping gradually over Europe towards our own shores, no one dreamed of taking any action with a view to staying the plague. But we must remember that it was a disease new to the modern generation of physicians—a disease with which the sanitary science of the present day had never had to cope—a disease whose cause was wholly unknown, and whose infectious character was imperfectly recognized, or even denied. Two years and

more under the yoke have given only too abundant opportunity to investigate it from every point of view, and it is not too much to say that the Local Government Board Report by Dr. Parsons, issued last year, contains the most admirable and exhaustive study of influenza which has appeared in any European language. Yet the actual nature of the virus remains still an only partially solved problem: bacteriological research points to a definite bacillus as the probable organism, but till its natural history has been more thoroughly worked out, we must be content to fight the foe in the dark.

Dr. Sisley has not reprinted his papers in chronological order, though it is convenient to consider them thus. In that read before the Epidemiological Society in May 1891, he treats of the spread of influenza by contagion, strongly advocating the view that this is the most important factor in the diffusion of the disease. He bases his belief on very conclusive grounds, and few will now be found to disagree with him. Dr. Parsons's Report, appearing some time after this paper was read, has so abundantly confirmed the opinion, that it may be trusted that, whatever part seasonal and climatic influences may play as favouring causes, “telluric” theories have had their day. The disease is, in fact, an acute specific fever infectious in a somewhat high degree, and, in virtue of its short incubation period, diffusing itself with unusual rapidity.

Only an abstract is given of the paper read by Dr. Sisley before the International Congress of Hygiene last August. It deals with the prevention of the spread of epidemic influenza, and advocates general hygienic measures, the possible employment of prophylactics, and especially the avoidance of infection.

The essence of the book lies, however, in the paper read before the Society of Medical Officers of Health in January of the present year. Here Dr. Sisley discusses the application to influenza of the existing sanitary laws of England, and it cannot be said that his conclusions are of a very reassuring character. It is instructive to observe that the difficulty lies in this—that nobody knows whether influenza is a “dangerous infectious disease” within the meaning of the Acts, or not. Common-sense might have supposed that a disease which the Registrar-General declares to have been directly or indirectly responsible for some 27,000 deaths in England and Wales in a single year, would not inaptly be described as dangerous; but the point has not as yet been settled in a court of law, and it is possible that legal opinion might take a contrary view. Should its dangerous character be upheld by law as well as medicine, the provinces have at least the Public Health Act of 1875 to fall back on, and can thus enforce isolation of early cases. London, under its new Act, is apparently helpless; and, as it would take twelve days to add influenza to the list of notifiable diseases, it is clearly unwise to wait for a fresh outbreak before taking such a step, if it be determined to take it at all. It cannot be doubted that efficient isolation of early cases would be the most important method of averting an epidemic; the difficulty lies in a matter which Dr. Sisley has not dealt with—namely, the diagnosis of such cases. Medical men now recognize as slight instances of epidemic influenza cases which in non-epidemic times would be passed over as

mere "feverish colds"; yet all such cases would have to be isolated in view of a threatened epidemic.

The extracts from the various Sanitary Acts appended to these papers form a very convenient work of reference for those interested in the subject, while the counsel's opinion on the powers of sanitary authorities as to influenza leave us very much where we were before. Dr. Sisley has, however, done valuable service in calling public attention to the inadequacy of our existing sanitary laws as a means of checking the spread of such a disease as influenza, and many will cordially indorse his opinion that "much improvement in this respect is not to be hoped for [until the sanitary service is consolidated, and becomes one fold under one shepherd—a Minister of Public Health.]"

#### OUR BOOK SHELF.

*Anthropogeographie.* Zweiter Theil. "Die Geographische Verbreitung des Menschen." Von Friedrich Ratzel. (Stuttgart: J. Engelhorn, 1891.)

THE first part of this work was published about nine years ago, and is still highly valued by all who care to study geography and anthropology from strictly scientific points of view. The present volume will also be found worthy of the author's reputation as one of the foremost authorities on all questions relating to the connection between man and the physical conditions by which he is surrounded. In the first part Dr. Ratzel deals with the habitable part of the globe, tracing the process by which man has taken possession of it, indicating the development of his ideas regarding it, and noting the characteristics of its northern and southern borderlands and of its vacant spaces. The second part he devotes to various aspects of statistics, discussing, among other things, the relations between density of population and degrees of civilization. In the third part are considered the traces and works of man on the surface of the globe—a subject which leads the author to treat of cities and their importance as historical centres, of ruins, roads and other means of communication between communities, and geographical names. The fourth and last part relates mainly to ethnographical questions, including questions as to the diffusion of ethnographical characteristics, and the origin of ethnographical affinities. The work is not only full of thought and learning, but has the advantage of being written in a fresh, clear, and vigorous style.

*Within an Hour of London Town: Among Wild Birds and their Haunts.* By "A Son of the Marshes." Edited by J. A. Owen. (Edinburgh and London: W. Blackwood and Sons, 1892.)

"A SON OF THE MARSHES" is now so well known that any new book by him is sure to find readers and admirers. He does not, of course, make important contributions to science. His writings merely record the impressions produced upon him by various aspects of nature in which he happens to be especially interested. But his impressions are so thoroughly true, and are presented in so vivid a style, that they may always be studied with pleasure. Even his talk about very common things has a certain charm, for he observes them accurately, and brings out by skillful touches their relations to other things that are not quite so intimately known. The present volume has all the characteristics of his previous books, and should do a good deal to foster in the mind of "the general reader" a liking for some of the more attractive facts and ideas of natural history.

NO. 1172, VOL. 45]

#### LETTERS TO THE EDITOR.

[The Editor does not hold himself responsible for opinions expressed by his correspondents. Neither can he undertake to return, or to correspond with the writers of, rejected manuscripts intended for this or any other part of NATURE. No notice is taken of anonymous communications.]

#### Exchange of Professorial Duties.

THE proposal of my friend Prof. Anderson Stuart, explained in the subjoined letter, seems to me one which may very probably commend itself to the professors and governing bodies of some of our Universities and University Colleges; and I therefore venture to ask for its publication in NATURE. By correspondence twelve months in advance, such an exchange as is here suggested could be arranged (with the assent of Senate, Council, or other authority), and would undoubtedly, where practicable, be of very great interest and advantage, not only to the teachers concerned, but also, in no less degree, to their classes.

E. RAY LANKESTER.

Oxford.

*Shepherd's Hotel, Cairo, February 13, 1892.*

DEAR PROFESSOR RAY LANKESTER,—In conversations with teachers in Europe during my two visits (1890-91, 1891-92) they have again and again said how much they would like to visit the colonies for pleasure, health, or the opportunity of study, as the case might be; but of course they could not, being bound by their duties. On the other hand, the benefit to the colonial teacher of a periodical visit to the older centres of learning has all along been recognized.

Soon after my return to Sydney in March 1891, it occurred to me that it would be easy to secure at once a visit of a European teacher to the colonies and of a colonial teacher to Europe by a temporary exchange of duties. Every now and again it happens that a teacher must provide for the duties of his office by a substitute, as is done by the colonial teacher when absent on leave, and by the European teacher most frequently, perhaps, when ill. Why, then, should not two teachers in a subject, who could trust each other, agree to apply for leave of absence, each proposing the other as his substitute for the time specified? I cannot see that any governing body could reasonably object to the proposal, and so the arrangement would be concluded.

Immediately on my return to Europe in October last I spoke of the matter, and amongst others to yourself; and since then I have discussed it with many friends, one of whom referred to it approvingly at a recent meeting of the Royal Colonial Institute. The project becomes the more feasible the more one studies the details of carrying it out. Practically one's attention is confined to America and Australasia. A study of the periods of the University terms, and of the steamship time-tables, shows that it is feasible for the latter, which is by far the more distant—about five weeks.

Of the pleasures of the voyage, and of the advantages to be derived by the residence in the other land, I need not speak, for each may form his own estimate of these; but that "there is something in" the thing I am persuaded, and I should be glad of your help in ascertaining what that something may be.

I am, dear Professor Ray Lankester,

Yours faithfully,

T. P. ANDERSON STUART,  
Professor of Physiology, University of Sydney.

#### Magnetic Storms.

EXACTLY twenty-seven days from the magnetic storm and splendid aurora of February 13-14, which has already been mentioned in NATURE, there was on March 12 another very fine aurora in the United States and Canada, and it also was accompanied by a powerful magnetic storm. This correspondence to the time of a synodic revolution of the sun, to which attention has been called by the writer many times within a few years past, is interesting, showing as it does that the motion of rotation is concerned to an important extent in the recurrence of magnetic storms and their accompanying auroras. The evidence is accumulating constantly showing that solar disturbances have their maximum effect upon terrestrial magnetism when at the eastern limb and at or near the latitude of the plane of the earth's orbit. If the great sun-spot to which the aurora of

February 13 has so generally been ascribed was really responsible for that outbreak, there should have been a series of displays, for this spot was very large and apparently active throughout its transit. As a matter of fact, whatever auroral effect the disturbed region in its vicinity was able to exercise fell about February 2-4 and February 29. Upon the latter date there was a fine display, but upon the former it was generally cloudy.

M. A. VEEDER.

Lyons, N. Y., March 23.

#### Pilchards.

I was very sorry to find from Mr. Dunn's letter (p. 511) that I had not reported his evidence on the occurrence of young pilchards with perfect accuracy. He admits that the misunderstanding was probably not altogether my fault. It seems that in the days before the railway existed in Cornwall, and when seines were largely used at Mevagissey for the capture of pilchards, small pilchards under 8 inches in length, of the same size as French sardines, were often taken in vast numbers, but were either allowed to escape, or used only as manure. The sentence in my article, therefore, which states that Mr. Dunn had never seen such pilchards must be corrected, and I make the correction most willingly, regretting that I should have unconsciously misrepresented Mr. Dunn's statement.

But I must warn your readers against the idea that my article on the growth of the pilchard contained nothing which Mr. Dunn had not discovered and made known years ago. The letter to which he refers in Buckland's "Familiar History of British Fishes" deals with the subject of curing pilchards in oil, and contains nothing whatever about the rate of growth of the fish. It merely mentions that if small fish were wanted they could be had in quantities: "Some seasons their smallness is a pest to the fishermen, and millions have been returned to the sea after being inclosed in the seines, because of being no money value." But Mr. Dunn acknowledges that I correctly reported him as saying that no such small sardines have been taken since the factory at Mevagissey was started, and that no pilchards of the same size as French sardines have ever been tinned in Cornwall. As for his exhibit of a series of pilchards from those an inch in length up to the two years old full-grown fish, I find that it is only catalogued in the Polytechnic Society's Report, and that no dimensions are mentioned, nor any description given. My published evidence on the rate of growth in this species was therefore by no means superfluous, and I am glad to find that my conclusions confirm those which he had already formed, but for which he had sought no satisfactory means of publication. I have often received and acknowledged with the greatest pleasure valuable information from Mr. Dunn: in this instance I was unaware that he had collected any evidence on the subject beyond that which I acknowledged in my article.

But while correcting misunderstandings on my part, Mr. Dunn misunderstands part of my article far more seriously. I stated that the adult sardine of the Atlantic coast of France was of the same size as the full-grown Cornish pilchard, while the sardine of the Mediterranean, taken at Marseilles, was considerably smaller. I did not say that the English pilchard was "larger than those of other countries," and I did not say that the Spanish pilchard was smaller than the Cornish. My "informants" were Prof. Poucher for France, and Prof. Marion for Marseilles; and the accuracy of their published observations on the mere question of size is not in the least affected by any grave doubts, however much italicized, on Mr. Dunn's part.

Plymouth, April 5.

J. T. CUNNINGHAM.

#### Ornithology of the Sandwich Islands.

YOUR correspondents, Prof. Newton and J. E. Harting (p. 532), are a little hasty in their conclusions referring to the Banksian collection.

In order to make things clearer, I will go a little further back in the history of this matter.

When the Linnean Society removed from 32 Soho Square, Dr. Brown was left in possession of that portion which had been built upon and used by Sir Joseph Banks as his museum.

Mr. John Calvert, partly out of veneration for the old house where so many men of science had from time to time met together, and partly from want of additional space for his very extensive museum and library, secured a long lease of these premises, including the old museum; so by that arrangement Dr. Brown

became his tenant. Now, it is a well-known fact that a portion of the Banksian collection was never removed from these premises, and remained the property of Dr. Brown, at the death of whom, Mr. J. Calvert arranged with Dr. Bennet (one of his executors), who had been for months removing van-loads of books, herbariums, and other articles of scientific interest, to purchase and take over, with the premises, various cases of birds, sundry articles, and the remainder and refuse of this large collection.

In two cupboards on the south side of the gallery were the ethnological relics collected during the voyage of the *Endeavour*, as well as many manuscripts in the autograph of Sir Joseph Banks, together with some of the catalogues of his collection.

On November 10, 1863, there was a sale at the rooms of Mr. J. C. Stevens by order of the Council of the Linnean Society. We soon detected the case of birds, which matched in every particular the cases that we purchased of Dr. Brown's executor; it had the same handwriting at the back, undoubtedly in the autograph of Sir Joseph. We also detected, in a cabinet of fossils and minerals which had belonged to Dr. Pulteney, one of the volumes of Sir Joseph Banks's catalogue, which matches the other volumes we had previously obtained: that volume still contains the stamp of the Linnean Society.

Lot 174 of this sale was a very large lot in boxes and a cabinet; added to which was a good proportion of the dirt and dust of bygone times. This collection had been formed by Dr. Martin with great care and industry, and contained various figured and type specimens, being all named in the quaint nomenclature of that period. At the bottom of one of the drawers of the cabinet was a letter in the autograph of the great Linnæus.

We purchased all these, together with others in that sale.

The Duchess of Portland, Sir Ashton Lever, and Sir Joseph Banks, were the great collectors of that period; and the Owhyhee case of birds might have been obtained by Sir Joseph either by purchase or otherwise at any date during his life. We have this case marked Owhyhee in the undoubted autograph of Sir Joseph Banks. The birds are all badly set up, and one has fallen from its perch, but underneath each one is a number which is referred to in one of Sir Joseph's catalogues.

In our Museum there are several thousand specimens which formed portions of the three collections just named, with regard to which we have absolute proof of identification, and in some cases the old lot tickets still remain.

As our museum is densely packed in several houses, and in some instances there are large cabinets four and five rows deep, it is not possible at a few hours' notice to dig out all and everything connected with this matter; but I will at the earliest opportunity bring the Banksian collection to the front, which I shall give a full description of in print, for the satisfaction of all those who are interested in the matter.

As to the collection of eggs of Mr. J. D. Salmon, we knew this collection well, but have never seen it since his death. There is not one single specimen in our museum that belonged to that collection, nor did we ever make a catalogue of the same, as the very exhaustive and elaborate catalogue made by the owner would be amply sufficient for all purposes.

ALBERT F. CALVERT.

63 Patshull Road, N. W.

#### First Visible Colour of Incandescent Iron.

HAVING read in your number for March 24 (p. 484) a letter on the above subject, I thought it might prove interesting to try a similar experiment with the carbon filament of an ordinary incandescent lamp. That used was an Edison Swan 16 candle-power 80 volt, and the method employed by heat it was to pass a gradually-increasing current (supplied from accumulators), using a water resistance gradually diminished by the addition of very dilute sulphuric acid in sensibly equal portions. The room in which the experiment was performed was very carefully darkened, and the observers were kept in darkness some minutes before the current was switched on, the dilute acid being added, so that, after visibility had been reached, five additions should bring the lamp to dull redness (by diffused daylight. The number of the experiment being called out, each observer wrote this down, together with his impression of the colour, *in the dark*, so that the retina was not affected by any extraneous light throughout. Each observer closely inspected the filament till he felt satisfied as to the colour, and then rested



his eyes in the dark till the next observation. There were twenty-five observers. The result seems worthy of notice.

(1) Of the twenty-five all agree that the colour of the filament is at first very pale. Thirteen call it very pale yellow, three call it white, seven a faint pink, two a bluish white.

(2) All agree that, as the temperature rises, the tint grows deeper and redder, passing through orange before reaching crimson. The words used to designate the final tint reached in the experiment vary from deep reddish orange to copper colour, dark red, blood red, crimson.

I may add that some of the observers had had considerable practice in observation, and their eyes were known to be normal so far as the perception of the tints of the visible spectrum is concerned. There is no reason to suppose that more than one, or two at most, possessed any abnormal sense of colour.

Assuming that in the cases of iron and carbon light of greater frequency of vibration is emitted as the temperature rises, in addition to the light emitted at lower temperatures (the vibrations causing which are merely increased in amplitude), is it not possible (1) that the selective power of the pigments of the retina at first scarcely comes into play, the slower vibrations acting on all to a certain extent, on the red more than the green, and the green more than the violet, in the normal eye? or (2) Does not the fact that all colours are more difficult to distinguish in a faint light, e.g. moonlight, make it likely that very weak irritation of any part of the retina (I mean a part which causes the sensation of light, and that coloured, when the irritation is stronger) is perceived as "light," the indication of specific absorption not being strong enough in comparison with the total amount of irritation to produce the sensation of any special colour in the light perceived? or lastly, if we do not make the above assumption, it would seem that iron and carbon at all events emit, when first visible, light of far wider limits of frequency of vibration than, so far as I know, is generally admitted.

Some photographic experiments which I hope may throw fresh light on the subject have been begun.

Eton College Laboratory, April 4.

T. C. PORTER.

#### Self-Registering Weather-cock.

I SHOULD be grateful if any of your readers would kindly recommend me a simple, inexpensive instrument, to automatically register the movements of a weather-cock above the roof.

Such an appliance must roughly indicate the direction of the wind at the time being.

Some years ago, a London builder put me up a very expensive instrument, which, beyond making considerable noise, was utterly useless.

J. LAWRENCE-HAMILTON.  
30 Sussex Square, Brighton, April 11.

#### THE ROLLING OF SHIPS.

ONE fact that often strikes the thoughtful traveller by sea is that, notwithstanding the great and numerous improvements of recent years which have made life on shipboard pleasant and luxurious, little or nothing has been done to steady a vessel when she meets with waves that set her rolling heavily from side to side. The tendency seems to be rather in the direction of increased than of diminished rolling; for the steadying influence of sails, which makes the motion so easy and agreeable in a sailing ship, is fast disappearing in large steamers. Masts and sails add appreciably to the resistance of large fast steamers; so they have been cut down in size year by year till such fragments of sail as still remain are so small compared with the size of the ship as to retain little power to reduce rolling.

Shipowners and seamen do not show much sympathy with the discomfort and misery that rolling causes to most passengers. They perhaps get anxious about an occasional vessel that acquires the evil reputation of being a bad roller, because passengers may be frightened away and the receipts fall off in consequence; but beyond wishing, or attempting, to deal with abnormal cases, nothing seems to be thought of. Rolling is considered incurable, or as not of sufficient importance to trouble

about. Yet there is nothing which would contribute so directly to the comfort of landsmen at sea, or do so much to change what is for many misery and torture into comfort, as to check and reduce as far as possible the rolling proclivities of ships.

The laws which govern rolling are now well understood, and it is strange that this knowledge has not enabled an effective means of control to be devised. What is stranger still is that well-known means of mitigating rolling—such as the use of bilge keels—are employed in but very few cases. A ship rolls about a longitudinal axis which is approximately at her centre of gravity, and the rolling is practically isochronous at moderate angles in ordinary ships. The heaviest rolling occurs when the wave-period synchronizes with the natural period of oscillation of the ship. Many vessels are comparatively free from rolling till they meet waves of this period, and if such meeting could be avoided, excessive rolling could be prevented. Some vessels have periods as long as fifteen to eighteen seconds for the double oscillation, and as these would require to meet with waves 1300 to 1500 feet in length, in order to furnish the conditions of synchronism, it is seldom that they suffer from heavy or cumulative rolling. Such waves are, however, not rare in the Atlantic.

The limits of heavy rolling are fixed, of course, by the resistance offered by the water and air to the transverse rotation of the ship, which is very great because of the large areas that directly oppose motion in a transverse direction. But for this resistance, and the condition that rolling is only isochronous within moderate angles of inclination, a few waves of the same period as that of a ship would capsize her.

The two most obvious modes of preventing heavy rolling are, therefore, (1) to make the period of rolling of a ship as long as possible, so as to reduce the chances of meeting waves whose period will synchronize with it, and (2) to increase the resistance to rolling. The period of a ship varies directly as her radius of gyration, and inversely as the square root of her metacentric height. Hence the period may be increased by increasing the moment of inertia of the ship, or by decreasing the metacentric height. In armoured war-vessels the moment of inertia is large, on account of the heavy weights of armour on the sides, and the heavy guns that are either placed at the side or high up above the centre of gravity. Ordinary steamers have no such weights concentrated at great distances from the centre of gravity, and their moments of inertia are determined by the distribution of material in the hull that is fixed by structural conditions and by the stowage required for their voyages. Metacentric height cannot be reduced below a certain amount, which is necessary to prevent too easy inclination of the ship, or crankness, in still water. On the whole, we may regard the longest periods that the largest ships are likely to have with advantage to be about those named above, i.e. fifteen to eighteen seconds.

Length of period cannot give immunity against occasional heavy rolling; but increase of resistance reduces the angles of roll at all times, and especially when the angular velocity is greatest and the rolling is worst. Such resistance is furnished by the frictional resistance of the bottom of a ship and by the direct resistance of projecting parts of the bottom, such as the keel and the large flat surfaces below at the stem and stern. This resistance can be largely increased by means of bilge keels. The value of bilge keels is recognized in the Royal Navy, and the ships of the Navy have been fitted with them for many years with highly beneficial results. The advantage of bilge keels was proved beyond all doubt many years ago by careful experiments made in this country and in France; and the late Mr. Wm. Froude showed, by the trials he made of H.M.S. *Greyhound*

twenty years ago, that bilge keels of excessive size—3 feet 6 inches deep, and 100 feet in length, on a vessel 172 feet long—had only an insignificant effect upon speed throughout great differences of trim.

It is strange that the mercantile marine should not yet have adopted bilge keels, and obtained the undoubted advantage they give in steadiness. The number of ships that have them is comparatively few. There is an almost universal opinion and prejudice against their use, and the largest and finest passenger steamers have no bilge keels. This is in spite of the fact that, in cases where bilge keels have been fitted to try to check heavy rolling—and they have been of suitable size and properly placed—it has been found that the angles of rolling have been reduced by nearly one-half. There is a prevalent belief—which has no foundation in fact—that bilge keels are very detrimental to speed. We have said that Mr. Froude's experiments showed the contrary, even on trials made in still water; but it appears certain that at sea any trifling loss of speed which still-water trials might show would be more than compensated for by gain in speed when the vessel is prevented from rolling through large angles from side to side, and undergoing great changes of underwater form at every roll. Experience with ships that have had bilge keels added after running for some time without them shows that there has been no appreciable difference of speed or increase of coal consumption on their voyages.

Another, and a more heroic, method of stopping or reducing rolling would be to counteract the inclining moment of the ship caused by the ever-changing inclination of the waves by an equal and opposite moment, which would vary as the inclining moment varies. This has been attempted at different times and in various ways. It is essential to any degree of success, however, that the opposing moment brought into operation should be completely under control, so as always to act in the manner and to the extent required. The attempts to obtain a steady platform by freely suspending it, and making it independent of the rolling of the ship, have failed—apart from the practical difficulties of carrying out such an arrangement on a large scale—because the point of suspension oscillates when the ship rolls, and the platform acquires a rolling motion of its own. Weights, made of heavy solid material, which move from one side to the other of a ship subject to the action of gravity and rotation, fail because they cannot be made to act continuously in the manner required.

A degree of success has been achieved by admitting water into a suitably prepared chamber and leaving it free to move from side to side as the ship rolls. This has been done in several ships of the Navy, the case of the *Inflexible* being that which was the most carefully experimented upon. The movement of this internal water follows the inclination of the ship, but it lags behind, and thus tends to reduce the inclination. Its effect can be regulated by the quantity of water admitted into the chamber and by its depth. The *Inflexible* Committee state in their report that comparatively small changes in depth increase or diminish largely the extingutive power of the water. For various reasons—one of which is that while such a chamber is very effective in a moderate sea it fails in a rough sea when the rolling of the ship is greatest—and perhaps partly on account of the destructive and disturbing effect of 100 tons or more of water rushing from side to side of a ship over 60 feet wide—these water-chambers appear to have gone out of use in the Navy, and they have been given up in the *City of New York* and *City of Paris*, which vessels were said to be fitted with them when first built and placed upon the Atlantic.

Mr. Thornycroft has devised a means of checking rolling by moving a weight, under strict control, from side to

side of a vessel so as to continuously balance, or subtract from, the heeling moment of the wave slope. It consists of a large mass of iron in the form of a quadrant of a circle, which is placed horizontal, with the centre on the middle line of the vessel, and there connected with a vertical shaft. The shaft is turned by an hydraulic engine, which is very ingeniously controlled by an automatic arrangement. The heavy iron quadrant is swept round from side to side, revolving about its centre, to the extent that is required to counteract the heeling moment. In a paper read on the 6th instant before the Institution of Naval Architects, Mr. Thornycroft said:—

“The manner in which the controlling gear works will be better understood if we imagine a vessel remaining upright among waves, while near the centre of gravity of the ship we place a short-period pendulum suspended so as to move with little friction; this will follow the change in the apparent direction of gravity without appreciable loss of time, so that any change in the wave angle and apparent direction of gravity cannot take place without due warning, which will indicate the time and amount of the disturbance. It is therefore only necessary to make the motion of the ballast bear some particular and constant ratio to the motion of this short-period pendulum to keep the balance true. The inertia of a heavy mass will cause some loss of time, as we can only use a limited force for its control; but it is possible to accelerate the phase of motion and overcome this difficulty so far as to get good results.

“If, now, we imagine the ship to roll in still water, the effect of the combination just described will be to balance the ship's stability for a limited angle; but this defect is removed by the introduction of a second pendulum of long period, which tends to move the ballast in the opposite direction to the first one, and enables the apparatus to discriminate between the angular motion of the water and that of the vessel.

“I find, however, that the long-period pendulum is rather a delicate instrument, and that its function can be served by a cataract arranged so as to always slowly return the ballast to the centre, and this device has the effect of accelerating the phase of motion, which, in some cases, we also require.

“We are therefore able, by very simple parts, to construct an apparatus which will indicate the direction and amount of motion necessary to be given to the ballast at a particular time so as to resist the wave effort; this power of indicating may be converted into one of controlling by suitable mechanism. The loss of time due to inertia of the necessary ballast is not always unfavourable when the apparatus has to extinguish rolling motion, the greatest effect being obtained when the ballast crosses the centre line of the ship at a time when it is most inclined to the water surface, and this corresponds to a quarter of the phase behind the motion of the short pendulum.”

The apparatus has been working for some time in the steam yacht *Cecile* with very good results. What the objections may be to applying it to the largest passenger steamers remains to be seen. A moving weight of something like 100 or 150 tons would probably be required in such vessels. The power necessary to control the movement of the weight appears to be small, and Mr. Thornycroft's invention seems at any rate to show the way towards obtaining the long-desired boon of substantially reducing, if not checking altogether, the rolling of ships. If it succeed in doing upon a large scale only a portion of what is claimed for it in the way of anticipating and counteracting the heeling effect of waves, without the possibility of acting in an erratic or undesirable way, we may hope to see it adopted some day in passenger steamers.

TRAVELS AMONG THE GREAT ANDES OF  
THE EQUATOR.<sup>1</sup>

MR. WHYMPER'S expedition to the Great Andes of Ecuador, occupied him from December 1879 to July 1880. The results were briefly indicated in communications to the Royal Geographical Society and the Alpine Club, but the full description has been long in coming. Horace recommended giving literary work nine years to ripen: Mr. Whympfer has more than followed his advice. Possibly the delay may be a mistake from a commercial point of view, but it is a gain to the readers when a book of travel in an interesting region is not written in a hurry and rushed through the press, but is rendered complete in every detail with an almost loving care.

The principal object of Mr. Whympfer's journey was to observe the effect of greatly diminished atmospheric pressure on the vital powers. There was already very strong cumulative evidence that, at elevations of rather more than 14,000 feet above the sea, serious inconveniences were often felt, such as difficulty of breathing, acute headache, a sense of extreme prostration, and sometimes hæmorrhage. Some of the symptoms, some of the suffering on record,

forbade travel in the very highest region of the Andes, so that ultimately the mountains of Ecuador were selected as the most lofty accessible district.

Chimborazo being the culminating peak of this group, the ascent of this was the main object of Mr. Whympfer's expedition. He determined to encamp on its slopes at gradually increasing heights, with the aim of ultimately reaching the summit. "But as there was no certainty that this could be done, and a possibility, at least, that the results of the investigation might be of a negative character, various other objects were kept in view; chief among them being the determination of the altitudes and relative positions of the principal mountains of Ecuador, the comparison of boiling-point observations and of aneroids with the mercurial barometer, and the collection of specimens, botanical, zoological, and geological, at great heights." Mr. Whympfer was accompanied by two Alpine guides—one being the well-known Jean-Antoine Carrel, of Val Tournanche, whose sudden death on the Matterhorn in 1890 was so generally regretted among mountaineers; the other, his cousin Louis. Of their services and willing help at all times, he speaks in the highest terms. Chimborazo had been attempted without success by Humboldt and by Bousingault; Cotopaxi



FIG. 1.—Crossing the Great Arenal.

might doubtless be attributed to other causes; still the connection between "mountain-sickness" and diminished air-pressure appeared to be indubitable. The problem had already been investigated, so far as could be done in the laboratory, by M. Paul Bert, and an account of his experiments forms an appendix to Mr. Whympfer's book. Balloon ascents also had been made, one with disastrous results; for of three aeronauts who had remained for some time at a height of from 26,000 to 28,000 feet, two had died, and the other had narrowly escaped with his life.

But a balloon ascent is an unfairly severe test, since the atmospheric pressure is so rapidly diminished; so Mr. Whympfer determined to encamp for some time at an elevation at which others had begun to suffer, and from that level to "carry exploration and research up to the highest possible limits." The Himalayas were at first selected as the place for these investigations, but, before he could start, the attempt to construct a "scientific frontier" aroused so many jealousies that, in all probability, the experiments and the life of the operator would have been simultaneously cut short. War also

had been ascended, but very few of the other high peaks in Ecuador, though many measurements of altitudes had been made by Drs. Reiss and Stübel in 1871-73, who kindly placed their results at Mr. Whympfer's disposal.

Mr. Whympfer spent 212 days in the upland or mountain district of Ecuador. During 204 nights of this period the barometer never gave a reading higher than 22.51 inches, or the observers were over 8000 feet above sea-level; during 90 of these it ranged from 21.72 to 21.11 inches (9000 to 10,000 feet); during 36 it was 18 inches or less (above 14,000 feet); during 19 it stood between 16 and 17 inches (15,801 to 17,285 feet); and on one night the reading was 14.75 inches, corresponding with a height of 19,500 feet. He landed at Guayaquil on December 9, and reached Guaranda (nearly 9000 feet above the sea) after crossing the Pacific range of the Andes, of which Chimborazo is the culminating point, by a pass about 10,400 feet above the sea. In preliminary explorations on that mountain Mr. Whympfer ascended to a height of about 12,900 feet, and his guides, on another occasion, to about 16,500; and his party left Guaranda to attempt the ascent on December 26. They passed the first night at a height of 14,375 feet, on the great sandy plain known as the Arenal, without feeling the slightest inconvenience

<sup>1</sup> "Travels among the Great Andes of the Equator." By Edward Whympfer. With Maps and Illustrations. (London: John Murray, Albemarle Street, 1892.)

ished pressure, and next day pitched the second camp at a height of 16,664 feet (pressure 16.5 inches). This was reached without inconvenience, but the mules during the last six or seven hundred feet of the ascent had shown marked and unusual signs of exhaustion. Mules and drivers were sent back, and the explorers remained in excellent health and spirits, but about a couple of hours afterwards all three were suddenly and almost simultaneously prostrated; their respiration became laboured, "accompanied by spasmodic gasps or gulps," they suffered from acute headache, with feverish symptoms, and an "indescribable feeling of illness pervading almost the whole body. . . . The attack seemed to arrive at a maximum quickly, to remain equally intense for several hours, and then it died away imperceptibly." In about 36 hours the Carrels got better, and felt well enough, on the

Carrel was suffering severely from the effects of frost-bite.

How the investigation was continued may be read in the book. In addition to excursions to lower points, Mr. Whympier, with one or both of his guides, ascended the following mountains: Corazon (15,871 feet), Cotopaxi (19,613 feet), where they encamped for the night, close to the brink of the crater, Pichincha (15,918 feet), Sincholagua (16,365 feet), Antisana (19,335 feet), Cayambe (19,186 feet), Sara-urcu (15,502 feet), Cotocachi (16,391 feet), and Carihuairazo (16,515 feet), all but the first three being new ascents. The Carrels also reached the summit of Illiniza (17,405 feet), and on two other occasions Mr. Whympier arrived within a few hundred feet of it. The expedition concluded with a second ascent of Chimborazo, when the travellers were favoured with better weather,

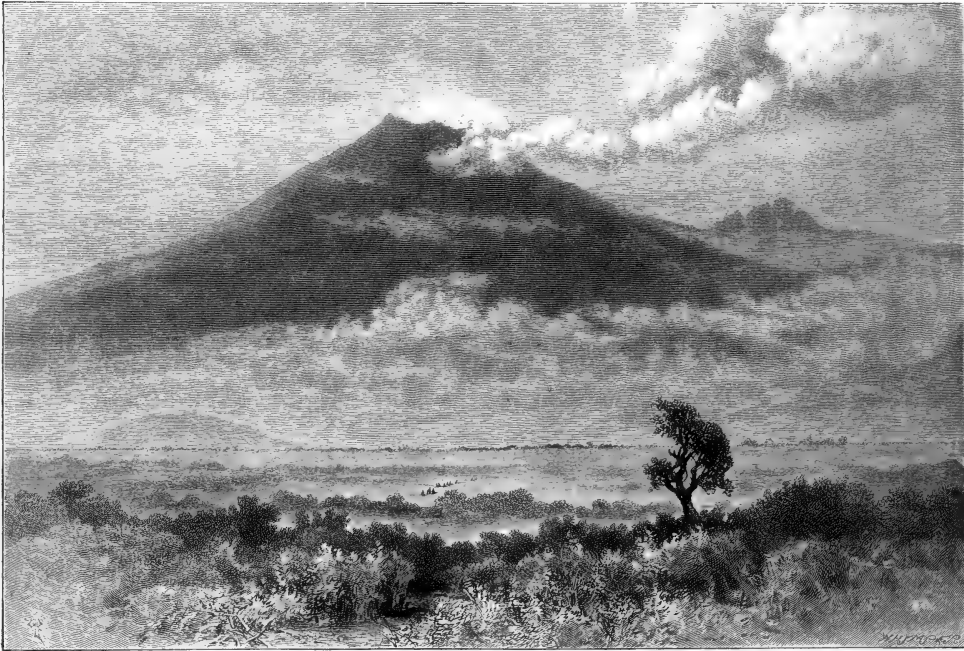

FIG. 2.—Cotopaxi.

29th, to set off for a preliminary exploration; they reached a height of about 19,300 feet, but were much exhausted when they returned in the evening. Mr. Whympier recovered rather more slowly, but during the whole time Mr. Perring, a native of the country, who remained with them at the camp, was unaffected. On January 2 they moved on to a height of 17,285 feet, and after an attempt next day, frustrated by bad weather, which appears to be almost chronic in the mountains of Ecuador, reached the summit (20,498 feet) on January 4. The weather was still unfavourable, and the work laborious, but they progressed more slowly than they would have done under similar circumstances in the Alps. They remained at the camp till January 10—for Mr. Whympier contemplated another visit to the summit under more favourable conditions—but were then obliged to return to Guaranda, as Louis

and with an exceptionally interesting incident. As they were mounting the slopes, Cotopaxi was full in view, nearly sixty miles away. Suddenly it ejected a column of "inky black smoke" to a height of about 20,000 feet above the lip of the crater. At this elevation the cloud was caught by an easterly wind, and borne at right angles to its former course; then it was taken by a northerly current and carried down upon Chimborazo. When the party reached the summit, at 1.20 p.m., the snow was still perfectly white; but, before long, the dust began to fall thickly, shutting out all view, penetrating into instruments, and adding an unpleasant condiment to their food. It had taken rather more than 7½ hours on its aerial journey. During these excursions, neither Mr. Whympier nor his guides suffered any return of the severe symptoms which they had experienced on the flanks of

Chimborazo; but he proves, by his careful and elaborate observations, that, though they became somewhat habituated to low barometric pressures, their bodily powers were sensibly diminished. In his own case this appeared to begin at a pressure of about 21 inches (roughly, 10,000 feet above the sea). He comes to the conclusion that, after some habituation, life can be sustained, when the body is at rest, at a height of 20,000 feet or more; but "when in motion it becomes difficult to enlarge the breathing capacity to the extent necessary to meet the further demand for air which was the result of muscular exertion."<sup>1</sup>

During these laborious expeditions Mr. Whymper was constantly occupied in carrying out the other objects of his journey. The physical geography of the region was studied, sketch maps were constructed, and many specimens of rocks and volcanic dust were collected, espe-



FIG. 3.—The contents of a grave.

cially from the higher points. The mountains (except Sara-urcu, the rocks of which are crystalline schists and gneisses) all consist of volcanic rocks, varieties of andesite. Cotopaxi and Sangai are still active; in some of the others, even the craters cannot be distinguished. The glaciers were carefully observed, for Mr. Whymper has proved that, contrary to the received statement, glaciers are by no means rare in the Ecuadorian Andes. Botanical and zoological collections were made, especially from the higher localities. Lichens were found as high as 18,400 feet, mosses to about 16,660 feet, grasses nearly as high, with a few Phanerogamous plants; the highest *Lycopodium* found was at 15,871 feet. *Coleoptera*, *Orthoptera*, *Rhynchota*, and *Lepidoptera* were all found at or a little above 16,000 feet, and *Arachnida* nearly as high. *Crustacea*, *Reptilia*, and *Batrachia* are rare; and Mr. Whymper could only obtain one fish (the noted

#### SCIENCE AT THE ROYAL MILITARY ACADEMY.

MANY of our readers will have seen that on Thursday last Sir Henry Roscoe asked the Secretary of State for War whether the military authorities were aware that at present it is possible for a cadet at the Royal Military Academy to pass through the course of work required of him successfully, and even to win admission to the Royal Engineers, without gaining a fair elementary knowledge of any branch of experimental science, and whether Mr. Stanhope would investigate and remedy this evil.

<sup>1</sup> I have never suffered (when otherwise in good health) from mountain-sickness in the Alps, but have often observed that I got "out of breath" more quickly in ascending peaks above 10,000 or 11,000 feet. This was especially noticed in an ascent of the Matterhorn, when, owing to threatening weather, I went as fast as possible up the last thousand feet or so.

*Cyclopium cyclopium*), which he does not believe to be ejected from Cotopaxi. These have been examined by various specialists, whose reports are summarized in the work, and some of them are collected in a supplementary volume, which will receive a separate notice. Mr. Whymper also made an interesting collection of stone implements and of ancient pottery, of which many specimens are figured. In one of the appendices he discusses the results of observations of mercurial and aneroid barometers. These, though of much interest, we must pass over.

In the space at our disposal it has been impossible to do justice to the varied topics of this volume. It must suffice to remark that Mr. Whymper has more than maintained the reputation which he won in his well-



FIG. 4.—"This is very old, Señor."

known "Scrambles along the Alps." The present work is admirably written, clear and terse in style, and often enlivened with a spice of dry humour. Of the illustrations it is almost needless to speak; they are even better than those in the former book. Some are delightful renderings of comic incidents; others represent stone implements, pottery, insects, and various examples of the Ecuadorian zoology; others are pictures of the mountain scenery, including the upper part of Chimborazo and the summit crater of Cotopaxi. The book, in short, is not only a record of pluck and endurance (for the hardships, lightly as they are treated by Mr. Whymper, were often great), but also a literary success, and a contribution to science of no small value.

T. G. BONNEY.

We understand that this step has been taken by Sir Henry Roscoe because the disadvantageous position of cadets who have entered the Royal Military Academy with a knowledge of science as compared with the position of those who have offered a second modern language at the entrance competition,<sup>1</sup> makes it increasingly difficult to maintain science studies in the Army sides of public schools. It may also be expected before long to have the effect of seriously diminishing the proportion of officers in the scientific branches of the Army who have had the advantage of such a prolonged study of experimental science as was admitted to be desirable when this subject was discussed a few years ago.

The answer made by Mr. Stanhope was partly of a satisfactory character and partly not so. He undertook to investigate the subject to which his attention was

<sup>1</sup> Usually, we believe, the second selection is German.

called. But, on the other hand, his reply reveals the fact that the educational authorities of the War Office still fail to see that science studies, like all other studies, must, in the case of the young, be somewhat prolonged in order to properly develop their value and render their effects permanent; especially if only a moderate portion of time can be devoted to them. For he stated that so far no cadet has gained admission to the Engineers without a fair knowledge of chemistry and physics. Now, as a good many of the cadets enter upon their work at Woolwich with little or no knowledge of these branches of science, as ten subjects are studied at the Royal Military Academy, and as the whole course of work only covers two years, it seems clear that the elementary knowledge in question must often be of a very elementary character indeed, however excellent the teaching may be, especially when it is remembered that some of the cadets doubtless have but little taste for such studies, and that the scientific faculties of these will have become more or less weakened by disuse during their previous course of training, which frequently has included no experimental science subject for several years.

The following are the circumstances of the case. The course of instruction at Woolwich occupies two years, which are divided into four terms. At the end of the second term, the choice of joining the Engineer Division is offered to the candidates in order of merit as indicated by the marks obtained in the first two terms. But no cadet can be posted to the Engineer Division who does not obtain 50 per cent. in fortification.

The marks for the obligatory subjects are:—

Mathematics <sup>1</sup> ... ..	3000
Fortification ... ..	2000
Military Topography ... ..	2000
French or German ... ..	1000
Chemistry and Physics ... ..	1000
Model Drawing ... ..	300

In addition, each cadet may take up a second modern language as a *voluntary subject* (in practice this is usually German), marks 1000—50 per cent. being the counting minimum; and landscape drawing is also a voluntary subject, marks 700, and counting minimum 50 per cent.

To count marks in any of the obligatory subjects, at least 25 per cent. of the total must be obtained.

For class promotion at the end of the first and second terms, candidates are required to obtain 50 per cent. of the marks in mathematics, and in at least three out of five obligatory subjects, and 50 per cent. of the aggregate.

Thus it appears that a candidate who had learnt no science at school might gain admission to the Royal Engineers in spite of failing in science at Woolwich.

Experience of this system as it works at the Royal Military Academy shows that in consequence of the very low minimum counting mark of science, even a beginner must be very dull or very idle to prevent him from counting the subject, especially as the teaching is suitable for beginners. Consequently, though chemistry and physics are nominally compulsory, anything beyond a very slight degree of proficiency is really a voluntary matter, especially as the effect of low marks in them can be compensated by marks obtained for a voluntary modern language by those who have offered two modern languages at entrance. The converse of this is not possible. For the voluntary modern language, in consequence of its high counting minimum mark, and in the absence of any really elementary teaching of the subject at the Royal Military Academy, cannot be made to count, as a rule, in the very limited time available, by those who have not

taken it as one of their subjects at the entrance examination.

The result is that at the end of the second term those cadets who have taken two modern languages at the entrance competition may not only score a high mark for a voluntary language, but can also easily gain a helpful mark in science; whilst those who have taken up one modern language, and a branch of science, can only as a rule count marks in one subject at the later stage. As the competition for Engineers is very keen, the latter class are at a serious disadvantage. In short, the taking up of a second modern language at the entrance examination is made almost compulsory by the present system, much to the loss of those candidates whose abilities are greater in other subjects.

The state of things which we have endeavoured to make clear in a few words has only lately been realized by schoolmasters and parents, through the reports of former pupils and others who are familiar with the matter. The result has been that there is now often great pressure upon teachers to send up candidates with two modern languages, and no science for the entrance examination, even when they believe that to take up one modern language, and a branch of science would give the boy an equally good or better chance of gaining admission into Woolwich, and would be of far greater professional value to him afterwards. It is therefore certain that, unless it be shown that these views are wrong, or the conditions are amended, there will soon be a distinct diminution in the proportion of candidates offering science from the public schools.

The present situation is unfair to candidates whose abilities lie in the direction of science. It tends to keep out of the scientific branch of the Army the specially scientific candidates. It will tend, also, to keep boys from public schools out of the Army, and replace them by those who have resorted to Continental tutors. And finally, by discouraging the teaching of science in Army classes, it must make it increasingly difficult to maintain a high level of science work at schools generally. We therefore hope that those who are with us in this matter will take any steps they may be able, to secure that the opportunity created by Sir Henry Roscoe shall not be lost.

#### THE LATE SIR WILLIAM BOWMAN.

TO many of the readers of NATURE the distinguished man of science whose life was so unexpectedly brought to an end a little more than a fortnight ago, was best known as a great ophthalmic surgeon who for a long period of years occupied the first rank in his own line of professional work. But to those of us who are old enough to remember what physiology and anatomy were forty years ago, the name of Bowman has very different associations. It recalls to us a series of splendid anatomical discoveries communicated to the Royal Society between 1840 and 1850, of which the chief results were afterwards brought together in the great work which Bowman subsequently published in association with Dr. Todd on the "Physiological Anatomy of Man." In the following paragraphs I have endeavoured to give a sketch of the most important of these discoveries, in the hope that the many scientific friends to whom his memory is dear may find it, however imperfect, yet acceptable for his sake.

The three most important subjects of Bowman's researches were: (1) the structure of muscular fibre, (2) the structure of the kidney, and (3) that of the mucous membrane of the alimentary canal.

(1) *The Structure of the Fasciculus of Striated Muscle* (Phil. Trans., 1840).—It had been recognized that the fasciculus of striped muscle is made up of what Fontana designated as "*his charnus primitifs*"; and much more recently

<sup>1</sup> 800 additional marks for higher mathematics, but cadets cannot count these papers if they do not obtain at least 40 per cent. of the marks.

Schwann had shown that the muscular substance is enclosed in a sheath of structureless membrane, which he described as produced by coalescence of the cylindrical cells from which it had originated. Bowman was the first to observe that the "sarcous substance," as he called it, *i.e.* the organized content of this tubular sheath, is capable of being split, not only longitudinally into fibrils, but also into disks, and founded on this observation a new view of its structure—namely, that the sarcous substance consists of *cylindrical parts* ("sarcous elements"), each of which is a segment of a fibril. Bowman's observations were confirmed by Kölliker in the admirable account of the structure of muscle given in the first edition of the "Gewebelehre," published in 1850. He, however, still regarded the existence of "sarcous elements" as open to question. A few years later they acquired a new title to recognition when Brücke, in his researches on the structure of muscle with the aid of polarized light, discovered that the sarcous substance, as observed by this method, behaves as if it were made up of "a system of cylindrical bodies, each having the properties of uniaxial crystals with their axes parallel to that of the fasciculus." Brücke did not pledge himself to the identity of these cylindrical bodies (which he called "disdiaklasts") with Bowman's "elements," but rather regarded each such element as a system of disdiaklasts. It would occupy too much space to enter on this subject further. It must suffice to say that the relation between the optical properties of sarcous substance and its microscopical characters was soon fully recognized, and that Bowman's sarcous elements still hold their own in every discussion on the structure of muscle.

(2) *The Structure of the Mucous Membranes of the Alimentary Tract.*—On this subject Bowman's investigations were fundamental. If anyone were disposed to doubt their claim to have been the starting-point of the long series of researches by which our present knowledge of the subject has been attained, he might at once satisfy himself by comparing the clear account of the subject contained in Bowman's article in the "Cyclopædia of Anatomy" (1843) with the vague statements which are to be found in the best work on "General Anatomy" then in existence, Henle's "Allgemeine Anatomie," published immediately before. The contrast is striking. Within the compass of a very few years Bowman had succeeded in unravelling the structure of mucous membrane, and arriving at new conceptions of the relations between its constituent parts, which have survived to the present day, notwithstanding the infinite amount of work which has been done since, in the same field of inquiry—an achievement which appears the more worthy of admiration when it is remembered that Bowman began as it were from nothing, and had to rely on his own ingenuity for devising his methods, and on his own dexterity for carrying them out. For at that time and for many years after, the methods of preparing tissues so as to display their structure, which are now in everyone's hands, were practically unknown.

*The Structure of the Kidneys.*—The great discovery which was announced in Bowman's paper on the structure and use of the Malpighian bodies of the kidneys (Phil. Trans., 1842) was that of the connection between the Müllerian capsule and the uriniferous tubes. The anatomists of the time were unanimous in denying the existence of any such communication, and Müller himself—who, in his great work on the intimate structure of the secreting glands, published in 1830, gave the first account of the capsule—characterized the suggestion that it might be connected with the ends of the uriniferous tubes as a "*falsissima opinio.*" In the edition of the "Handbuch der Physiologie," however, which immediately followed the appearance of Bowman's paper, the great physiologist frankly admitted his error.

The result next in importance of Bowman's research

was the explanation it enabled him to give of the renal circulation. The knowledge which existed was extremely defective. For, although it was known that there was a communication between the capillaries of the glomeruli and those of the convoluted tubes, the belief that the capsules were closed sacs rendered it impossible to understand their relation to the renal function. They were indeed regarded merely as *retia mirabilia*, intended to check the impetuous blood-stream in its course towards the tubes. Müller had, two years before the publication of Bowman's paper, recognized that the renal tufts of *Myxine* are contained in the urinary utriculi, but the identity of these structures with the glomeruli of the higher Vertebrates was overlooked by him until Bowman's description served to explain his own observations on the renal organs of the lower.

The theory of the function of the kidney which sprang out of Bowman's anatomical investigations was shortly as follows:—The epithelium which lines the convoluted tubes is the mechanism by which the characteristic constituents of the urine are excreted. The water of the urine is discharged by the Malpighian tufts by a process partly physical, partly vital. These organs thereby serve as an apparatus for the regulation of the water-content of the blood, and thereby of the whole body. The grounds for the theory were (1) the distribution of the capillary blood-vessels on the external surface of the tubes; (2) the analogy of the renal epithelium with that of other secreting glands; (3) the absence of any such epithelium on the surface of the tufts; and (4) the consideration that, by the arrangement of their capillaries, the blood-stream through the tufts is retarded—a circumstance favourable to filtration. The theory was in so far "vitalistic" that it assumed for the secreting epithelium a special power or endowment, of which its structure afforded no physical explanation. It was soon met by another which regarded the whole process mechanically. Only two years after Bowman's second paper, Ludwig's article in Wagner's "Handwörterbuch" appeared, in which it was maintained that not only water but the salts and other soluble constituents of the urine are discharged by a process of filtration, and that the function of the convoluted tubes of the cortex is not to secrete the solids of the urine, but to reabsorb the water, and thereby concentrate the product. Without entering into details, it may be sufficient to say that the theory of Ludwig was chiefly based on experimental evidence relating to the immediate influence of purely mechanical conditions in determining the rate of secretion, which showed that the renal flow is instantly increased by augmentation and diminished by decline of the difference between the arterial and venous pressures, and consequently varies with the rapidity of the renal blood-stream. For twenty years this theory was tacitly accepted, until in 1875 Heidenhain published the first of those researches on the process of renal secretion which form the basis of our present knowledge, and which resulted in the reinstatement of the doctrine of Bowman that in the kidney, as in other glands, secretion depends on the active function of special secreting cells. The most material difference between the doctrine now taught as the outcome of the anatomical and experimental researches of the last two decades, is connected with a fact which remained unknown for many years after the completion of Bowman's work—that the glomeruli or Malpighian tufts are provided with epithelium, and that their function is not, as Bowman thought, merely filtration. The essential point of agreement is that the living epithelial cell contains in itself the essential mechanism for secretion, and that it is on it that the influence of all external conditions is primarily exercised.

In the fifty years which have elapsed since Bowman arrived at a true conception of the function of the kidneys, an enormous and wholly unprecedented progress has been

made in anatomical and physiological knowledge. The inferences to which he was chiefly guided by anatomical considerations have thus been placed on a wider basis, at the same time that they have been brought into complete harmony with the more certain evidence of experiment.

The above ragmentary account of Sir William Bowman's scientific work may suffice to show how much his early achievements aided the advancement of knowledge, and how materially they influenced the work of the other great anatomists and physiologists of that stirring time. Who can say how much more a man of such power would have contributed to the building up of the great science which in the vigour of youth he cultivated with such extraordinary success, had not external circumstances withdrawn him—too early—from its service?

J. BURDON SANDERSON.

#### NOTES.

THE new London County Council seems to have rather more enlightened ideas as to the need for the promotion of technical education than its predecessor. On Tuesday, when it was moved that the recommendation of the Finance Committee with regard to the Council's receipts and expenses for the year ending March 31, 1893, should be adopted, Mr. Quintin Hogg proposed as an amendment that the following words be added to the motion:—"Provided that £30,000, being part of the amount receivable by the Council for the financial year ending March 31, 1893, under the Local Taxation (Customs and Excise Duties) Act, 1890, be carried over to a suspense account, instead of being applied in reduction of rate, and that such £30,000, when carried over, be dealt with on or before October 1 next by the Council for any purpose authorized by the above Act; and that a special committee be appointed to consider what action the Council should take under the Technical Education Acts, 1889-91, and the Local Taxation (Customs and Excise Duties) Act, 1890, with power to draw up a scheme or schemes for the consideration of the Council." This was seconded by Mr. Baum, and warmly supported by Sir John Lubbock and other speakers. The amendment was adopted by a large majority, only three voting against it.

DR. SCOTT having accepted the charge of the Jodrell Laboratory at Kew, the Assistant-Professorship in Botany at the Royal College of Science at South Kensington will be vacant at the end of the present session. The appointment rests with the Lord President of the Council, and candidates for the post should send their applications to the Secretary, Science and Art Department, accompanied by testimonials. The salary is £400 per annum.

SIR ANDREW CLARK, F.R.S., has been elected for the fifth time President of the Royal College of Physicians of London.

MR. FRANCIS DARWIN, F.R.S., author of "The Life and Letters of Charles Darwin," has been elected a member of the Athenæum Club, under the terms of the rule which provides for "the annual introduction of a certain number of persons of distinguished eminence in science, literature, or the arts, or for public services."

THE Trustees of the British Museum have appointed Mr. Arthur Smith Woodward to the Assistant-Keepership of the Department of Geology in succession to Mr. Etheridge, who has been retired by the operation of the Order in Council of August 1890. A junior assistantship which thus becomes vacant will shortly be filled by competition among the candidates nominated by the principal Trustees.

MR. F. J. M. PAGE has been appointed to the Chair of Chemistry and Physics at the London Hospital rendered vacant by the death of Dr. Tidy.

DR. HUGH ROBERT MILL has been appointed to succeed Mr. J. S. Keltie as Librarian to the Royal Geographical Society.

WE have already announced that the Royal Medals of the Royal Geographical Society have been awarded to Mr. A. R. Wallace and Mr. E. Whymper. The Murchison grant has been awarded to Mr. Swan (who accompanied Mr. Theodore Bent in his expedition to Mashonaland); the Back grant to the Rev. James Sibree for his many years' work on the geography and bibliography of Madagascar; the Cuthbert Peck grant to Mr. Campbell for his important journeys in Korea; and the Gill Memorial to Mr. Garrett for his geographical work during the past fifteen years in Sierra Leone.

AT the meeting of the Royal Geographical Society, on Monday, Mr. Ernest Gedge read a paper on a recent Expedition under Captain F. G. Dundas, R.N., up the River Tana to Mount Kenia, in East Africa. He said that his account of the expedition had been compiled from the notes and journals of the European members thereof. In appearance the Tana might be likened to a miniature Nile for the whole of its navigable length, a distance of some 360 miles by river, flowing through a vast plain, and generally confined between low banks. The surrounding districts were flooded during the rise of the river in the rainy season. In fact, the whole country from Charra across to the Ozi River might be described as one vast swamp choked with rank vegetation. Only a small fraction of this area was cultivated at present. Above Hameyé, the river was a succession of rapids and falls; the channel was choked with boulders, and quite unnavigable. In fact, it had the general appearance of a mountain torrent of large dimensions. With regard to the geological structure on the upper reaches, this appeared to consist principally of gneissic formations above Hameyé, which, on nearing Mount Kenia, gradually changed to indurated hornblende schists, till on the mountain itself it again changed to basaltic rocks and volcanic ash.

DR. HENRY HICKS, F.R.S., has announced in the *Times* that during some recent excavations in Endsleigh Street, N.W., in connection with the deepening of the main sewer, the workmen came upon the remains of a mammoth and other prehistoric animals at a depth of about 22 feet from the surface. In the central excavation, near the north end of the street, two large tusks of a mammoth were met with lying near together along with other bones belonging to the same animal. A portion of one of these tusks was brought to the surface, and it was found to measure at its thickest part nearly 2 feet in circumference. The length of the complete tusks would probably be at least 9 feet or 10 feet. In another excavation on the west side of the street, at a distance of about 15 feet from the above-mentioned, the lower jaw and other bones of a younger mammoth were discovered at about the same depth from the surface. The dark loamy soil in which the remains were embedded has yielded on examination many seeds of contemporary plants; and Mr. Clement Reid, of the Geological Survey, to whom samples of the loam were submitted, has been able to determine the presence in it of about twenty species. These show that the land at the time was of a marshy nature. Deposits usually classed with the high-level gravel and brick earth of the Thames Valley were found overlying the animal remains; hence the geological age during which the animals lived, in Dr. Hicks's opinion, must be included in what is known as the Glacial period.

A BUST of Gustav Nachtigal has been set up in the Berlin Museum für Völkerkunde, beside the collections formed in the



course of his travels. At the unveiling of the monument interesting speeches were delivered by Freiherr von Richthofen, Dr. Bastian, and others.

THE sixth summer meeting connected with the University extension scheme at Edinburgh will take place in August, and promises to be of great interest. The arrangements include "a geographical and technical survey of Edinburgh and district." There will also be a course on the teaching of physiology and hygiene, with a series of evening lectures by prominent specialists on the problems of technical education. A course on sociology will be given by Prof. Geddes; on anthropology, by Prof. Haddon; on general biology and zoology, by Mr. A. Thomson; on physiology, by Prof. Haycraft; and on botany, by Messrs. Turnbull and Herbertson. Occasional lectures will be given by a number of gentlemen, among whom will be several representatives of foreign Universities.

THE Geologists' Association are to devote the Easter holidays to an excursion to Devizes, Swindon, and Faringdon.

THE Geographical Section of the London Geological Field Class will take their first excursion, under the personal direction of Prof. H. G. Seeley, F.R.S., on the afternoon of Saturday, April 23, when they will visit Reigate. Full particulars can be obtained from the general secretary, R. H. Bentley, 31 Adolphus Road, Brownswood Park, N.

BOTANISTS have long been accustomed to publish sets of "Exsiccati," especially of micro-fungi, which have been widely distributed among specialists in the groups dealt with. Sets of *Coccidæ* prepared by Mr. T. D. A. Cockerell, the Curator of the Museum at Kingston, Jamaica, are to be issued by the Institute of Jamaica on much the same plan, and it is hoped that they will be of service not only to students, but also to horticulturists and those interested in agriculture in tropical countries, who often have to contend with scale insects, which they rarely have the means of identifying. The first set, including ten species, all from Kingston, has already been issued.

AT the twenty-third annual meeting of the Norfolk and Norwich Naturalists' Society, held on March 29, Mr. H. B. Woodward, F.G.S., was elected President for the coming session. Dr. F. D. Wheeler, the President, read the annual address, in the course of which he stated that during the past year the Society had lost by death six members, to one of whom—the Rev. H. P. Marsham—it was indebted not only for the register of the "Indications of Spring," begun by his great-grandfather, R. Marsham, F.R.S., of Stratton Strawless, in 1736, and continued with only one break to the present time, but also for the letters of Gilbert White to that gentleman, printed in the *Transactions* for 1874-75. Dealing with the subject of the gradual extinction of many of the species of Lepidoptera that once inhabited the fens, Dr. Wheeler said he thought the direct action of man might in most cases be wholly disregarded. Indirectly, by draining the fens, man was no doubt responsible for the extinction of many of their peculiar denizens, but even this cannot account for all, since some insects disappeared or became very rare without any striking change in the locality they inhabited. He considered that such changes were generally due to climatic causes, the insects being possibly on the extreme limit of their geographical area. In some cases the gradual drying of the fen might, by affecting the food-plant, prove fatal in the end to the larvæ feeding on it.

AT the meeting of the Linnean Society of New South Wales on February 24, Mr. J. H. Maiden read a paper on *Panax* gum. Resinous exudations have been mentioned for many years as occurring in non-Australian Araliaceæ, but no details of composition, much less of analyses, are, it is believed, in existence.

A true gum has been recorded as occurring in a New Zealand *Panax*. The author now describes true gums from *P. sambucifolius* var. *angusta*, *P. Murrayi*, and *P. elegans*. They closely resemble certain *Acacia* gums, but may be distinguished in practice by slight odours of a peculiar character.

THE Meteorological Council have recently issued, in the form of a preface to the Daily Weather Reports for July to December 1891, a series of tables giving the monthly means for pressure, temperature, and rainfall at twenty-eight stations. The values are for twenty years, 1871-1890, and in the case of rainfall, for twenty-five years, 1866-90, and they will be very useful for reference in various climatological questions. The tables show that the mean pressure is uniformly higher over the southern portion of the British Islands than over the northern, but the difference is less in summer than in winter; in April the means are more uniform than in any other month. The temperature tables give the means of the dry-bulb and wet-bulb, and the mean maximum and minimum values, together with the means of the latter. Taking the mean of the minimum and maximum values for January and July, as representing the coldest and hottest periods of the year, we find that Cambridge is the coldest place, while both Loughborough and York are colder than some of the Scotch stations. The hottest station is London, 72°·4, and Loughborough is 71°·5. The wettest station is Valentia Island, the total fall for the year being 56·6 inches; the next wettest place is Roche's Point, where the annual fall is 47·8 inches. The driest station is Spurn Head, where the total yearly fall is only 20·9 inches. The average yearly fall in London for a quarter of a century is 24·99 inches.

SPANIARDS are making a good many preparations for the celebration of the four hundredth anniversary of the discovery of the New World. In the autumn of the present year there will be several Exhibitions, in one of which will be shown objects relating to the continent of America before the advent of Europeans, while another will illustrate the state of civilization in the colonizing countries of the Old World at the time when the new continent was discovered. In October the Congress of Americanists will meet at Huelva, and will discuss a variety of subjects relating to the continent of America and its inhabitants 400 years ago. In the same month, at Madrid, a Spanish-Portuguese-American Geographical Congress will meet for the discussion of such questions as relate more particularly to the "Iberian-American" races, their aptitude for colonization, and the future of the Spanish language.

It is expected that the diamond industry of South Africa will be well represented at the Chicago Exhibition. The collection from Cape Colony will include 10,000 carats of uncut stones, a large quantity of very fine cut and polished ones, together with all that is necessary to show the process of mining and washing. For this it will be necessary to transport to Chicago 100 tons of pulverized blue earth, 50 tons of unpulverized earth, and a complete washing machine, which will be "operated" by natives.

THE first number of the *Irish Naturalist* has been issued, and will doubtless receive a cordial welcome in Ireland, where no other journal of the kind exists. It is a monthly periodical, and for the present each issue will consist of only sixteen pages. The paper starts with the support of all the Irish Natural History Societies.

THE burial mounds of sand in Florida are rapidly disappearing in consequence of the way in which they are disturbed by treasure-seeking natives and relic-hunting tourists. Mr. C. B. Moore has therefore done good service by giving in the February number of the *American Naturalist* an account of a somewhat remarkable burial mound previously unopened. It stands on Tick Island, Volusia County, Florida, and is conical in shape, except towards the east, where from the summit a gradual slope

extends into a winding causeway or breastwork. The height of the mound is 17 feet; its circumference, 478 feet. Its base is composed of shells, apparently brought from the neighbouring shell fields to serve as a foundation in the marshy soil. Across the centre of this layer of shells from north to south runs a ridge of pure white sand, above which is a stratum of dark sandy loam mingled with shells, while the sides of the ridge are rounded out with sandy loam in which shells are wanting, thus forming a symmetrical mound. During the excavations over a hundred skeletons were exhumed, and Mr. Moore does not doubt that many hundreds still remain. Although careful searchers examined every spadeful of sand, not a bead of glass nor a particle of metal was discovered, so that the mound had probably ceased to be used for burial purposes when Florida began to be occupied by white men. Many fragments of pottery were found, and various ornaments and stone weapons.

THE Pittsburgh Electric Club, according to an account of it given by the American journal *Electricity*, seems likely to be a successful institution. It was organized nearly a year ago, and is a corporation of the State of Pennsylvania. Its aim is primarily to aid in the progress of electrical and mechanical science, and incidentally to promote social intercourse among those interested in this main object. By the time it completes its first year of existence it will have 200 members. Every electric company in the United States is represented in its membership. The Club has already provided itself with "a large and luxurious home," several of the rooms of which are effectively represented among our contemporary's illustrations.

AN interesting paper on the manufacture and use of aluminium, from an engineering stand-point, by Mr. Alfred E. Hunt, President of the Pittsburgh Reduction Company, is printed in the current number of the *Journal of the Franklin Institute*. Mr. Hunt is strongly of opinion that financially the most successful solution of the aluminium problems of the future will be in the way of utilizing the metal in the arts rather than in devising more economical methods of manufacture. He gives a very good account of the uses to which aluminium has already been applied. We may note that it has been successfully used instead of lithographic stone. Powdered aluminium mixed with chlorate of potash is used to give a photographic flash-light, which produces much less smoke than the magnesium compounds used. An aluminium has been produced for the coating of iron, and Mr. Hunt thinks that this will undoubtedly be considerably used in the future.

ACCORDING to the *National Druggist*, the sunflower is found to be of great service in Southern Russia, where it has for some time been extensively cultivated. It is grown principally for the bright yellow, colourless, and tasteless oil yielded by its seeds. That oil is said to be superseding olive oils throughout Southern Russia for domestic purposes. The pressed seeds and the boiled leaves (the latter mixed with clay) serve as cattle food, the stalks as fuel. Like the eucalyptus, the sunflower possesses the property of drying marshy soil, and counteracts the development of malaria germs.

A VALUABLE paper on photography applied to the detection of crime, by Dr. Paul Jeserich, was read at a recent meeting of the Photographic Society of Great Britain, and has now been printed in the *Society's Journal and Transactions*. Among the subjects with which the author deals is the application of photography to the detection of the falsification of handwriting. In such cases photography can be of great service, as in an enlarged photographic picture erasures and alterations can be more clearly seen than in the original. But, above all, photography can be used to demonstrate in the resulting picture differences in inks which cannot be perceived by the eye. Dr. Jeserich claims that by his method, the outcome of many years' experience, it is possible to demonstrate differences in the colours of the inks

which cannot be seen, the one ink appearing light and the other dark. This process depends on the following considerations:—As is well known, the tints of the inks that are called black are either brown, red, green, or blue in shade. Such tones have but little effect on the eye, as it is chiefly sensitive to the yellow and red rays, but the chief sensitiveness of photographic plates, on the other hand, lies in the blue, violet, and ultra-violet. As, with ordinary sensitive plates, yellow and green subjects are rendered dark, and blue ones light, the same will follow in photographing inks of various tones. This difference can be considerably intensified by the use of suitably coloured light, and colour-sensitive plates. In this manner marked differences in the various inks can be clearly and distinctly demonstrated. After the reading of the paper, Captain Abney, the Chairman, said he once examined an engraving which was reputed to be of value, and by means of photography he was able to bring out the original signature under a spurious one, which had been added. The picture turned out to be worthless.

SOME correspondence has been going on in the *New York Nation* about the present position of the study of psychology as a science in the United States. Mr. E. W. Scripture is very far from being satisfied with it. One or two pioneers in the use of scientific methods have, indeed, achieved some success; but this, says Mr. Scripture, "ought not to blind us to the fact that by far the large majority of our so-called Universities teach a psychology which would call a blush of shame to the face of old Aristotle, the father of the science, for the degeneration of his offspring in the last two thousand years. To attempt to console ourselves by pointing out the entire lack of psychological facilities in England (except in the Cavendish Physiological Laboratory), is like trying to persuade the New Yorkers of the charms of bossism because the Czar of Russia is worse than Hill."

PERHAPS the most noticeable contribution to the new number of the *Journal of the Royal Agricultural Society of England* is a paper by Mr. Carruthers, explanatory of a series of eight diagrams, illustrating "The Life of the Wheat Plant from Seed to Seed," which the Society has recently published. These notes will be very useful, and, judging from the woodcuts in the *Journal*, the diagrams themselves are likely to prove of considerable value to agricultural lecturers and teachers. Amongst the reports, that from the Royal Veterinary College is interesting; it deals mainly with the subject of foot-rot in sheep, and furnishes very strong evidence of the contagious nature of the disease; further investigations are in progress with the bacteria found in pus from the diseased surfaces. Mr. R. E. Prothero contributes an interesting historical sketch of farming in England, under the title of "Landmarks in British Farming."

*Himmel und Erde* for April contains some interesting notes on the nature of Jupiter's surface; the observations which Christopher Scheiner made with his instrument about the year 1625, with two illustrations, one showing a perspective view of the instrument itself, the other being a representation of the solar surface, on which are situated several spots that were visible on the sun from April 18 to May 1, 1625; an article by Dr. A. Fock on a "Problem of Chemical Mechanics"; and a paper by Dr. Leize on the "End of the Age of Alchemy, and the beginning of the Iatrochemical Period."

PART 13 of the "Universal Atlas" that is being published by Messrs. Cassell and Company contains maps of the British Empire, The Caucasus, and Greece. In the first of these all the well-known currents are charted, and in addition, the commercial routes of the world, which form such a network of lines, especially in the Atlantic Ocean, are inserted. Three smaller maps on a larger scale show in greater detail these steamship lines in the neighbourhood of Western Europe, the West Indies, and the Mediterranean.

THE anhydrous sulphates of zinc, copper, nickel, and cobalt have been obtained in well-developed crystals by M. Klobb, who describes his experiments in the current number of the *Comptes rendus*. It was first observed that when a small quantity of the ordinary hydrated sulphate of cobalt was allowed to fall into fused sulphate of ammonia it immediately dissolved, imparting a deep blue colour to the liquid, and when the heating was continued in such a manner that the ammonium sulphate slowly volatilized away, the walls of the crucible were found to be covered with small red crystals. Upon analysis these crystals proved to be those of anhydrous cobalt sulphate. Similar experiments with the hydrated sulphates of zinc, copper, and nickel succeeded equally well, and it was found to be immaterial whether the hydrated salts with five, six, or seven molecules of water, or the amorphous anhydrous salts obtained by ignition, were employed. The best mode of operating in order to obtain good crystals is briefly as follows. A quantity of ammonium sulphate is placed in an ordinary porcelain crucible; over this is then laid an intimate mixture of ammonium sulphate with one-third its weight of the metallic sulphate required. The crucible, covered by its lid, is then inclosed together with a packing of sand within a Hessian crucible, which is afterwards placed in a muffle furnace and heated until the sulphate of ammonia has all escaped. The heating should then be at once discontinued in order to prevent decomposition of the metallic sulphate. After cooling, if the heating has been carefully conducted, the residual metallic sulphate is found to be crystalline throughout, and to consist largely of single well-formed crystals. The result is particularly good in the case of zinc sulphate. If quantities of about twenty grams of anhydrous zinc sulphate are employed, colourless octahedrons two and a half millimetres long may be obtained. These crystals only dissolve with extreme slowness in cold water, but are much more rapidly dissolved upon warming. Sulphate of copper treated in a similar manner yields prismatic needles of the anhydrous salt. These crystals present a pale grey appearance, but on being left exposed to the air for a few days they assume first a green tint and subsequently pass over to the ordinary pentahydrated blue salt. Unlike the crystals of anhydrous zinc sulphate, they are rapidly dissolved by cold water, forming the usual blue solution. The crystals of anhydrous sulphate of cobalt prepared in like manner consist of brilliant red octahedrons, which are apparently unaltered by exposure to the air, and which are only slightly attacked by water even when boiling. Still more remarkable are the green crystals of anhydrous nickel sulphate obtained by the above mode of preparation, for these crystals, so unlike the readily soluble hydrated sulphate, are practically insoluble both in cold and boiling water. This last instance affords a striking example of the influence of water of crystallization upon the solubility of a salt.

THE additions to the Zoological Society's Gardens during the past week include an Entellus Monkey (*Semnopithecus entellus* ♂) from India, presented by Dr. Wm. Eames and Dr. Earle, R.N.; a — Owl (*Pseudoscops grammicus*) from Jamaica, presented by the Trustees of the Jamaica Institute; a Green Couure (*Conurus pavina*) from Trinidad, presented by Mrs. Hill; two Sharp-nosed Crocodiles (*Crocodilus acutus*) from Central America, presented by Sir Henry Arthur Blake, K.C.M.G.; two Common Vipers (*Vipera berus*), British, presented by Mr. A. Cotton, F.Z.S.; an Orange-winged Amazon (*Chrysotis amazonica*); two Mississippi Alligators (*Alligator mississippiensis*) from South America, a Manchurian Crosspiltion (*Crossoptilon mantchuricum*) from Northern China, four Spiny-tailed Mastigures (*Uromastix acanthinurus*) from North Africa, deposited; a Slow Loris (*Nycticebus tardigradus*) from Borneo, two Bar-breasted Finches (*Munia nisoria*) from Java, two Mute Swans (*Cygnus olor*), European, purchased; an Angora Goat (*Capra hircus* var.), born in the Gardens.

OUR ASTRONOMICAL COLUMN.

OBSERVATIONS OF THE SPECTRUM OF NOVA AURIGÆ.—Dr. Henry Crew, in *Astronomy and Astro-Physics* for March, gives a general description of the visible spectrum of Nova Aurigæ on February 10 and 11, observed by him with a spectroscope attached to the 36-inch of the Lick Observatory. The positions of the following lines were determined by direct comparison with the lunar spectrum and the spark spectra of hydrogen and magnesium:—

N. of line.	Wave-length.	Description.
1 ...	6565·8 ...	Probably C; very broad and bright in prism; not seen in grating.
2 ...	6321 ...	Faint, broad, diffuse.
3 ...	6209 ...	Not quite so bright as 2, but broader; both 2 and 3 may be bright only in comparison with neighbouring absorption bands.
4 ...	5898 ...	Yellow line, just below D.
5 ...	5265 } ...	Three very faint lines; difficult to say whether they are really bright lines or simply bright regions bounded by dark spaces.
6 ...	5254 }	
7 ...	5216 }	
8 ...	5167·1 ...	Much more brilliant than any of the preceding; quite broad; much sharper on the upper side than the lower; nearly coincides with δ <sub>4</sub> . The most brilliant part of the continuous spectrum is terminated abruptly by this line.
9 ...	5009 ...	Of about the same brilliancy as 8, and, like it, sharper on the upper side.
10 ...	4920 ...	About half as bright as 9.
11 ...	4861·6 ...	Probably F; not less than 6 tenths metres in width.
12 ...	4352 ...	Hγ? Wide and difficult to see.

A curve, showing the intensities of the lines as seen with a prism, accompanies this description. Prof. Young has determined the positions of twelve bright lines in the Nova spectrum (*Astronomical Journal*, No. 258). The wave-lengths are as follow: 4340 (Hγ), 449, 4861 (F), 4922, 5015, 5165, 5260, 5304, 559, 590 (D?), 632, 6563 (C). A faint line was also glimpsed below C, and another—probably h—above G. The lines at 4922 and 5015 are believed not to be nebular lines. Those at 559 and 632 are possibly coincident with the two principal lines in the aurora spectrum.

DENNING'S COMET (b 1892).—*Edinburgh Circular* No. 25 contains the following elements and ephemeris of Denning's comet, computed by Dr. R. Schorr:—

Elements.

T = 1892 May 6<sup>h</sup> 13<sup>m</sup> 22<sup>s</sup> Berlin M. T.

$$\begin{aligned} \pi - \Omega &= 126^{\circ} 39' 17'' \\ \Omega &= 252^{\circ} 55' 13'' \\ i &= 89^{\circ} 49' 45'' \\ \log q &= 0.298920 \end{aligned}$$

Ephemeris for Berlin Midnight.

1892.	h.	m.	s.	Decl.	Log r.	Log Δ.	Bright-ness.
April 15 ...	1	29	+	59 47' 0" ...	0.3024 ...	0.3989 ...	0.95
" 19 ...	1	49	52 ...	59 11.4 ...	0.3012 ...	0.4041 ...	0.93
" 23 ...	2	9	26 ...	58 29.1 ...	0.3002 ...	0.4095 ...	0.91
" 27 ...	2	27	43 ...	57 41.4 ...	0.2995 ...	0.4149 ...	0.89
May 1 ...	2	44	45 ...	56 49.5 ...	0.2991 ...	0.4204 ...	0.87
" 5 ...	3	0	37 ...	55 54.2 ...	0.2989 ...	0.4258 ...	0.85
" 9 ...	3	15	23 ...	54 56.6 ...	0.2990 ...	0.4311 ...	0.83
" 13 ...	3	29	7 ...	53 57.3 ...	0.2994 ...	0.4362 ...	0.81
" 17 ...	3	41	55 ...	52 56.7 ...	0.3000 ...	0.4411 ...	0.79
" 21 ...	3	53	52 ...	51 55.4 ...	0.3008 ...	0.4458 ...	0.77
" 25 ...	4	5	3 ...	50 53.8 ...	0.3020 ...	0.4502 ...	0.75
" 29 ...	4	15	32 ...	+49 52.0 ...	0.3034 ...	0.4543 ...	0.72

The brightness at the time of discovery is taken as unity. The comet passed about half a degree north of γ Cassiopeie on April 8, and is moving towards Perseus.

COMET SWIFT. 1892.—The following are places for this week for 12h. Berlin mean time:—

1892.	R.A.	Decl.
	h. m. s.	
April 16 ...	21 44 50 ...	+ 8 21' 2"
" 17 ...	21 48 13 ...	9 16' 5"
" 18 ...	21 51 35 ...	10 11' 1"
" 19 ...	21 54 55 ...	11 4' 9"
" 20 ...	21 58 13 ...	11 57' 8"
" 21 ...	22 1 30 ...	12 49' 9"
" 22 ...	22 4 45 ...	13 41' 2"
" 23 ...	22 7 59 ...	14 31' 6"

DISPLACEMENT OF RADIANT POINTS.—The late Dr. J. Kleiber left behind him a paper "On the Displacement of the Apparent Radiant Points of Meteor Showers due to the Attraction, Rotation, and Orbital Motion of the Earth." The paper appears in the March number of *Monthly Notices of the R.A.S.* The three principal causes of displacement mentioned in the title are treated separately, and the theory is illustrated by a consideration of the Perseid and Andromedid radiants. More than twenty years ago Schiaparelli developed formulæ for determining the amount of displacement of a radiant point due to the attraction of the earth. The effect of the attraction is to diminish the zenith-distance of every radiant and leave its azimuth unchanged. The corrections to be applied to the co-ordinates of the Perseid and Andromedid radiants on account of this disturbing cause were computed by Dr. Kleiber, and are given in his paper. It is shown that the latter swarm affords a good example of the displacement of a radiant due to the attraction of our planet. The rotation of the earth produces a small aberration of radiants, never amounting to more than 1° in the latitude of Greenwich. With regard to the earth's orbital motion, Dr. Kleiber found that it is sufficient to explain the displacement of 57° in right ascension, and 10° in declination, observed by Mr. Denning in the case of the Perseid swarm. And, after the proper corrections have been applied, it appears that of the forty-nine radiants catalogued by Mr. Denning as belonging to the Perseid shower, "forty-six lie within a circle described about the cometary radiant with a radius of 2°." This important result settles definitely the question as to the reality of the shift of radiant points.

TWO NEW VARIABLES IN CEPHEUS.—Mr. Paul S. Vendell, in the *Astronomical Journal*, No. 258, communicates the discovery of two variables of long period in Cepheus. One of them, D.M. 50° 2769, has a range of variation of a full magnitude (5.8 mag. to 6.8 mag.) in about a year. An interesting point is that "the star is apparently subject, especially near its maxima, to sudden and considerable fluctuations in light, often amounting to several steps from one night to the next." The star No. 8594 of Chandler's "List of Stars probably Variable" has been proved to be variable. The period is about 348 days, and the light-range about 0.7 mag., from 6.2 mag. to 6.9 mag.

ON THE VARIATION IN LATITUDE.—At the Paris Academy on March 28, M. Faye said:—"The question of the variability of latitudes has lately occupied the minds of astronomers and geodetists to a large extent. The Academy will hear with interest that this question appears to be settled in the affirmative by some observations that the Geodetical Association has recently had made at Honolulu. Whilst at Berlin, Prague, and Strasburg, the latitude increased 0".04 from June to September, and afterwards decreased 0".1 or 0".2 to December, and then diminished 0".13 to January, at Honolulu it varied in the opposite direction—that is, it fell about 0".3 from June to September, and increased 0".13 from December to January."

### THE INSTITUTION OF NAVAL ARCHITECTS.

THE annual spring meeting of the Institution of Naval Architects was held on Wednesday, Thursday, and Friday of last week, the President, the Earl of Ravensworth, occupying the chair during the whole of the sittings excepting that of Thursday evening, when Admiral Sir John Hay presided. The programme was not quite so long as usual, the Council of the Institution having come to the conclusion—wisely, we think—that it would be more desirable to have fewer papers and devote more time to their respective consid. ration. As it is now settled that the Institution is always to hold two meetings in the year, there is a chance of relief to what was always a congested programme when the business of the whole year was crowded into a single session. Where the summer meeting is to be held this year is not yet settled, but it is to be hoped that some place in

the provinces will be selected, as it is right that the great ship-building centres of the Kingdom, of which London is not one, should be visited by the leading shipbuilding institution.

The following is a list of the papers read, in the order in which they were taken:—On divisional water-tight bulkheads as applied to steamers and sailing-vessels, by B. Martell, Chief Surveyor Lloyd's Register of Shipping; on steady vessels at sea, by J. I. Thornycroft; notes on some recent experiences with H.M. ships, by W. H. White, C.B., F.R.S.; a ram buoy and the importance of rams in war, by Commander E. B. Boyle, R.N.; whale-back steamers, by F. C. Goodall; on an approximate rule for the vertical position of the centre of buoyancy, by S. W. F. Morrish; on balancing marine engines and the vibration of vessels, by A. F. Yarrow; some notes on the strength of steamers, by A. Denny; on the transverse stability of ships, and a rapid method of determining it, by W. Hök; notes on experiments with inflammable and explosive atmospheres of petroleum vapour, by J. H. Heck; on the theoretical effect of the race rotation on screw propeller efficiency, by R. E. Froude; performance of three sets of engines belonging to the second-class cruisers recently added to H.M. Navy, as calculated from the full-power steam trials, by Mr. J. G. Livesidge, R.N.

It is evident that the space at our command will not permit us to give anything approaching a full description of a meeting that occupied five sittings, some of them of over four hours' duration; and we will therefore concentrate our attention upon those points more especially within our scope. Mr. Martell's paper was one of great value, but it was treated from a purely constructive point of view. There are, it may be remarked in passing, some very nice mathematical and physical considerations involved in the study of the theory of bulkheads. This was pointed out by Dr. Elgar during the discussion, but up to the present we are not aware that the matter has been approached in a philosophic spirit. Before that can be done, certain experimental data must be obtained, and it will then remain for the mathematician to apply the canons of his science to the elucidation of the problems involved.

Mr. Thornycroft's paper on the steadying of vessels at sea was an account of some investigations and experiments carried out by one of our most scientific and careful mechanical engineers. Mr. Thornycroft has a steam-yacht, the *Cecile*, of 230 tons displacement. With this vessel he proceeded to make experiments with a view to reducing the rolling motion in a sea-way. The *Cecile*, it should be stated, is a bad roller, or, rather, a difficult vessel to prevent from rolling, as she has large meta-centric height and a flat rig; in other words, she has considerable stability. In this vessel Mr. Thornycroft fitted, under the cabin floor, a shaft, which was free to turn completely round its axis, and to this was keyed a mass of ballast weighing 8 tons. The shaft had a crank, which was actuated by an hydraulic motor. In this way the ballast could be moved out from the centre line of the ship, so as to counteract the rolling motion. The movement of the weight had naturally to be provided for by some automatic arrangement, and this was supplied by a short-period pendulum placed near the centre of gravity of the ship, and actuating the valves of the motor. So far, all is simple enough, but here the difficulties commence. The inertia of the heavy mass of ballast will cause some loss of time, as only a limited force could be used for its control, and Mr. Thornycroft sets himself the task of overcoming this difficulty. He therefore introduced a second pendulum, of long period, which tends to move the ballast in an opposite direction to the first pendulum, and this enables the apparatus to discriminate between the angular motion of the water and that of the vessel. Mr. Thornycroft found, however, that the long-period pendulum is rather a delicate instrument, and its function can best be served by a cataract arranged to always slowly return the ballast to the centre. This device has the effect of accelerating the phase of motion, which in some cases is required. Unfortunately, at this point Mr. Thornycroft's description breaks off. The mechanism by which the motion of the pendulum is made to govern the movement of the weight was described by Mr. Beauchamp Tower, who has seen it in operation, as "the greatest intellectual treat to all who appreciated the niceties of mechanical design." This intellectual treat was denied to the members of the Institution, for the mechanism was not described further than that it was an electrical device. Those, however, who have attempted to work with pendulums on board

ship will be sure that Mr. Tower did not exaggerate the ingenuity of its inventor; and we hope some day to have the details made public, more especially as the Director of Naval Construction—who was another of the favoured few who had seen the apparatus at work—stated that he felt sure it would have a wide application for other purposes than that for which it was originally devised. As a result, in a heavy sea in the Channel, the apparatus reduced a roll of 18° each way to one of 9° each way.

Mr. W. H. White's paper on recent experiences with H.M.'s ships had of course been looked forward to with considerable expectation and interest. The Director of Naval Construction has the art by which he can render interesting almost any subject upon which he writes. Probably, however, the paper was disappointing to many engineers, who were misled by the title into the belief that the great forced-draught and leaky-tube question was going to be fought out. As a matter of fact, Mr. White only referred to the boiler problem in order to inform his audience that he was going to say nothing about it; and the chief point to which he turned his attention was the influence of shallow water upon the trial trip speeds of modern vessels. In past times when speeds were more moderate, the Stokes Bay measured mile did well enough, but now that vessels have to be tried to 20 knots and over, the depth of water is wholly insufficient. Most of the measured miles on which ships are tried have an insufficient depth of water, the notable exception being the Skelmorlie course on the Clyde, which appears to be everything that can be desired, the water being both sheltered and deep. The Humber course is apparently the worst, as it is shallow in depth and very much exposed. In connection with this matter, an amusing incident arose during the discussion on Mr. White's paper. A patriotic Scots shipbuilder had been exulting in the superiority of the Scottish mile over all those on the English coast. He was followed by a Hull constructor, who acknowledged the excellence of the Skelmorlie trial ground, "which," he said, "doubtless largely accounted for the very excellent results attained by Clyde-built vessels." To return, however, to Mr. White's paper; he gives an instance of two sister vessels tried on the Maplin mile at different states of the tide. The variation in depth of water was 9 feet on 42 feet, and with the same power indicated there was a difference of half a knot in speed. The cruiser *Edger*, in Stokes Bay, with 12 fathoms of water, required 13,260 horse-power to attain 20½ knots; whilst in water 30 fathoms deep she reached 21 knots with 12,550 horse-power.

In running from the Nore to Portsmouth, the first-class cruiser *Blenheim* made 20 knots with 15,750 indicated horse-power in water 9 fathoms deep. On the same trip, when the vessel got into water of 22 to 26 fathoms, the speed rose to 21½ knots with practically the same horse-power. In this instance the estimated loss due to the shallower water was 3000 horse-power. Other examples were given by the author, and by other naval architects during the discussion, the most notable perhaps being that narrated by Mr. Philip Watts, the chief of the Elswick Ship Yard, who gave his experience with the Italian cruiser *Pimonte*, the results being very similar to those of the *Blenheim*. It is evident that depth of water has a far greater influence on speed trials than has hitherto been generally supposed, and it should be remembered that the smaller vessels, such as torpedo-boats, suffer almost as much as the larger craft. A vessel travelling at a given speed has to carry a wave of dimensions corresponding to the speed, whether the vessel be large or small, so that the size of the vessel does not affect the depth of water required, except in the important detail that a big vessel's keel is nearer the bottom than that of a small one. Vibration was another subject upon which Mr. White treated, but this question was so much more fully dealt with by Mr. Yarrow in the evening, that we may pass on to the paper of the latter contributor; skipping the three intervening, which were of less general interest.

Mr. Yarrow's paper on balancing marine engines and the vibration of vessels was undoubtedly the great feature of the meeting, as was his paper last year on the construction of marine boilers. Unfortunately it is impossible to give a good idea of Mr. Yarrow's lecture—for it was more than a paper—without the aid of the views by which it was illustrated. These were thrown, by means of the lantern and electric light, on a large screen erected for the purpose. As everyone knows who has been present on the trial trip of a torpedo-boat, the vibration in these little craft is excessive. The enormous power exerted by the engines, the rapidity of their reciprocations, and the slight

and elastic nature of the hull construction, all combine to render the deck of a torpedo-boat, travelling at her best speed, a most unpleasant position; especially when the spray is driven in sheets across the deck, and the white-hot cokes are at intervals emitted from the chimney. It is natural, therefore, that the question of vibration should be attacked, and to a great extent solved, by one of our two great torpedo-boat builders. Mr. Yarrow, some time ago, came to the conclusion that it was the reciprocating weights of the engines that caused vibration. There was long a general belief that the propeller was the origin of nearly all vibration in screw vessels, and the belief still largely exists; but those best acquainted with the subject have for some time known it to be erroneous. If the blades of a screw be properly balanced, and in other respects if the propeller is as well made as the screws of torpedo-boats have to be, there will be little difference in the amount of vibration whether the screw be in position or taken off, provided the engines are running at the same speed in both cases. Mr. Yarrow has proved these facts most conclusively by an elaborate series of trials made with working models and also with an actual torpedo-boat. The principal model represented to scale a three-crank tri-compound engine. This was hung in a frame by means of spiral springs. The weights of their pistons and other moving parts were as ordinarily arranged in a torpedo-boat's engines. The model was caused to work by means of a thin and flexible steel wire, so that no motion other than a rotary movement, could be conveyed to the apparatus. When the model was caused to work, at a given speed, the movement was excessive. In this way was very clearly brought out the fact, already known to engineers, that the vibration of a boat is at its maximum when the revolutions of the engine synchronize with the natural period of vibration of the boat. It will be seen that a boat or ship, like any other elastic structure, say a girder or a tuning-fork, will have a period of vibration natural to it. The reciprocations of the engine pistons cause a certain number of impulses to be communicated to the hull, and if the number of vibrations and the impulses are either one a multiple of the other, then the vibration will be excessive. This has been thoroughly proved by experience, and it has been the aim of builders of high-power vessels of light scantling to fit screws so designed that at maximum speeds the vibrations and revolutions of the engine will not synchronize. In Mr. Yarrow's model the elasticity of the hull was represented by the stiff spiral springs by which the model engine was suspended. Having shown the way in which the reciprocating weights of the engines acted so detrimentally, Mr. Yarrow next proceeded to explain the manner in which he overcame the difficulty. Attached to the model were weights, which he termed bob-weights. These were so placed as to balance the natural reciprocating parts of the engine. They were actuated by eccentrics, and could be put in and out of gear as required. With the bob-weight in operation, the effect was most marked, the model being perfectly steady at any rate of movement. The bob-weights have, of course, to be of the proper weight, and must be accurately placed in the longitudinal plane of the engine, otherwise the balance would be destroyed. This was shown by Mr. Yarrow with the model. He had first thought that a good effect might be obtained by making all three pistons of equal weight—the low-pressure piston is naturally far heavier than the others—but little benefit was obtained in this way. One of the most interesting parts of the lecture was the photographic pictures of torpedo-boats thrown on the screen by the magic lantern. These pictures were among the best of the kind we have ever seen. The boat was moored in the West India Docks so as to get still water, and a calm day was chosen. The propeller was removed so that the engines ran free. The first photograph was taken with the engine in its ordinary condition, no bob-weights being attached. By previous experiment the number of revolutions that caused the most vibration had been ascertained; we believe 240 per minute was the number, and the engines were run at that speed. The boat was therefore caused to vibrate excessively, and the effect was clearly shown by the waves or ripples thrown off from the side. These were beautifully marked in the photograph, the pattern caused by the intervening wave-series being very curious. Many pictures were given illustrating various wave phenomena due to different combinations, one of the most interesting being that in which vibration was caused by one of Mr. Yarrow's assistants springing on the stern 240 times a minute; an athletic feat of no mean order, and one which required considerable training.

Another series of photographs, taken broadside, very clearly showed, by means of the wave motion, the nodes of vibration due to the period; the straight and the broken water line being well defined. When the bob-weights were attached, this phenomenon was naturally not present, as the vibration was destroyed. Our description has extended so far beyond our proper allotment of space, that we have not been able to describe the "vibrometer" which Mr. Yarrow has devised, and by which he obtains automatic records of the vibrations of a vessel. This instrument, if not absolutely accurate, has been proved quite sufficient for the purpose. On the whole, one can hardly doubt, after hearing Mr. Yarrow's lecture, that he has found a practical solution to the vibration difficulty, which threatened to become one of such serious dimensions, not only in torpedo craft but passenger steamers, in these days of high speed and steel hulls.

The other papers we must pass over very briefly. Mr. Denny's monograph on the strength of steamers consisted virtually of a table with some explanatory notes. It represented a large amount of work, and will prove of great use to naval architects. Mr. Hök's contribution added another to those many "rapid methods" which from time to time are brought forward, but none of which have, so far as we are aware, yet superseded the older methods of calculating stability. Mr. Heck's paper was a useful contribution, explaining some simple methods he had devised for arriving at the state of the atmosphere in petroleum steamers.

On Friday the first paper taken was that of Mr. Froude, who may be safely described as our first living authority on the screw propeller in its scientific aspect. It will be remembered that the author has of late read a series of papers on this subject before the Institution. During the discussion on his contribution of last year Mr. Thornycroft suggested that some of the conclusions arrived at might be modified by the rotation of the race, and it was in order to elucidate this point that the investigation was undertaken. The present paper is the outcome of this. It would be useless to attempt to abstract, ever so briefly, a paper on so abstruse a subject as this; in fact, up to the present time we have not been able to give the day's preliminary study which Mr. Froude's papers require before we can fairly get a grasp of their drift. We should perhaps have hardly had the courage to make this admission had not two such past masters of the subject as Mr. Thornycroft and Mr. Macfarlane Gray confessed that they had devoted a day to the study of the paper, and still were not in a position to discuss it. The paper by Mr. Liversidge was the last read, and led to a short discussion, in which no point of special interest arose.

#### FOURTH ANNUAL REPORT OF THE DELEGATES OF THE OXFORD UNIVERSITY MUSEUM.

THE Delegates of the University Museum have presented their Report to Convocation for the year 1891. This Report consists of two parts: (1) the General Report of the Delegates, properly so called; and (2) the Departmental Reports of the Professors and Lecturers teaching within the Museum precincts.

The Delegates call attention to the improved accommodation provided, or in course of being provided, for the several departments of Comparative Anatomy, Zoology, Geology, and in the Pitt-Rivers Museum. These new and improved buildings will be fully available before the end of 1892. The result will be, in the Comparative Anatomy Department, by altering the old dissecting-room, to utilize it for convenient and well-lighted rooms for laboratory and museum work. The Geological Department, which has long been inadequately accommodated, will be enlarged by a long working-room and a store-room above. Two spacious store-rooms have likewise been provided for the department of Zoology and the housing of the Hope Collection. A Curator's room has also been provided for the Pitt-Rivers Collection, and additional facilities for the arrangement and storage of specimens.

The dissecting-room, lecture-theatre, museum, and assistants' and working rooms required for the department of Human Anatomy are in course of erection. They are expected to be available for use early in 1893.

Among the Professors' Reports, the Regius Professor of Medicine regrets that the University authorities have not seen

their way to provide, even on a modest scale, a Bacteriological Laboratory for the use of his department. But under the supervision of Dr. Carl Menge, recommended by Prof. Virchow, a small laboratory has been arranged in the limited space devoted to the department of Medicine. The apparatus was purchased in Berlin, and Dr. Menge, freed from duties abroad, conducted a class during the long vacation in the technique of Bacteriology. This class was not only attended by several gentlemen who had passed the M.B. examination, but interested many of the medical practitioners in Oxford.

Sir H. Acland hoped to investigate the condition of the waters in and about the Isis and Cherwell, in connection with the larger inquiry as to the bacterial condition of the water supplied to London, but for various reasons this investigation is for the present left in abeyance.

The Linacre Professor of Comparative Anatomy divides his report into two subdivisions: (1) the care and development of the collections illustrating the comparative anatomy and classification of animals placed in the court of the Museum, and (2) the administration of the laboratories and lecture-room assigned to his department.

In the first subdivision the Professor remarks that the specimens are rather stored in cases than "exhibited." By the aid of competent assistants, however, he hopes that the more typical specimens may be set out and labelled in a thoroughly demonstrative manner, after that introduced by Prof. Flower at the British Museum. A special case, illustrating the chief treasure of the Oxford Museum, viz. the head and foot of Ashmole's Dodo, is being made ready, and also a series of specimens, casts, and drawings, to exhibit the interest and importance of the six fossil jaws of Mammals from the Stonesfield Slate.

"The task of doing justice to the valuable collections belonging to the University, by adequately exposing, labelling, and arranging, some in exhibition cases, and by carefully recording and storing others, where they shall be readily accessible for the purposes of the student, is no light one. Even with a full staff of assistants it would take several years, and could never be 'finished,' any more than the books of the Bodleian Library could be finally arranged and left so for the admiration of future generations. The Natural History collection of the University requires constant care, special curators, and consequently a considerable annual expenditure, just in the same way as does its collection of books, though the former at present does not require so large a sum for its proper administration as does the latter. I have therefore to report that I have not sufficient funds at my disposal for carrying out the arrangement of the collections under my care with efficiency, or with reasonable promptitude."

The second part of the report shows the number of students attending the laboratory and lecture rooms. The number averages about thirty per term, and in addition to the ordinary lectures, informal meetings are held in which recently published memoirs on embryological and morphological subjects are discussed. Dr. Benham, Mr. Goodrich, Mr. Minchin, and Mr. E. B. Poulton and others have assisted the Professor in these informal classes.

The Curator of the Pitt-Rivers Museum gives a long catalogue of additions to his department, and remarks that the various series of musical instruments have been so far as possible completed, with labels, sketches, maps, &c. The weaving and bark-cloth series has been re-arranged, and similarly the series of mask, primitive boat models, and the fire-making series, which is one of the most typical in the collection.

The Report of the Lecturer on Human Anatomy has reference principally to the construction of the new laboratories referred to in the Delegates' Report. The Lecturer in the course of the summer vacation visited the medical schools of Strassburg, Munich, Freiburg, Vienna, Buda-Pest, and Brussels, in order to observe the most approved methods of teaching and museum arrangement, and also to inspect the recently built anatomical institutes of these various centres of medical education, with the view of using the information so obtained in the fitting up of the new Laboratory.

The remaining reports do not present any points of special interest. They include reports from the Hope Professor of Zoology, the Professor of Experimental Philosophy, the Waynflete Professor of Chemistry (who has had ninety-eight individual students at work under his direction during the year), and the Professors of Geology, Mineralogy, Geometry, Natural Philosophy, and of the Reader in Anthropology.

## SOCIETIES AND ACADEMIES.

LONDON.

Royal Society, March 31.—“The Abductor and Adductor Fibres of the Recurrent Laryngeal Nerve.” By J. S. Risien Russell, M.B., M.R.C.P. Communicated by Prof. V. Horsley, F.R.S. (From the Pathological Laboratory of University College, London.)

The first part of the following research consists in the separation and isolation of the different bundles of nerve fibres of which the nerve trunk is composed, electrical excitation of each separate bundle, and observation of the effects produced on the vocal cords by such excitation.

Exposure of the different bundles of nerve fibres, under exactly similar circumstances, to the drying influence of the external air, with observation of the relative duration of vitality possessed by the different bundles, forms the second part of the investigation.

Other methods were next instituted to control the results of the foregoing, and the first of these, constituting the third part of this work, consisted in tracing by *post-mortem* dissections each bundle of nerve fibres separated in the nerve trunk to its termination in the mucous membrane or in a muscle of the larynx.

The next control method consisted in exposing the muscles of the larynx immediately after death, and direct observation of them during excitation of the separate bundles of nerve fibres, this being controlled by occasional excitation of individual muscles themselves. This forms the fourth part of the investigation. The fifth or last part of the research served as a third control method, and consisted in observations of the muscular degenerations which followed division of one or other bundle of nerve fibres in the nerve trunk, three weeks after such division.

The results of these experiments show clearly:—

(1) That the abductor and adductor fibres in the recurrent laryngeal nerve are collected into several bundles, the one distinct from the other, and each preserving an independent course throughout the nerve trunk to its termination in the muscle or muscles which it supplies with motor innervation, a condition of things, the possibility of which was suggested by Dr. Semon more than ten years ago, from the evidence of pathological facts.

(2) That while in the adult animal simultaneous excitation of all the nerve fibres in the recurrent laryngeal nerve results in adduction of the vocal cord on the same side, abduction is the effect produced in a young animal by an exactly similar procedure.

(3) That when the abductor and adductor fibres are exposed to the drying influence of the air under exactly similar circumstances, the abductors lose their power of conducting electrical impulses very much more rapidly than the adductors—in other words, they are more prone to succumb than are the adductors—a fact which has for long been recognized and insisted on by Dr. Semon as being the case in the human subject, and in support of the truth of which that observer has adduced so many powerful arguments.

(4) That, even in the young dog, the abductor nerve fibres, though preserving their vitality much longer than in the case of the adult animal, nevertheless in the end succumb before the adductor fibres.

(5) That this death commences at the point of section of the nerve, and proceeds gradually to its peripheral termination, and does not take place in the whole length of the nerve simultaneously.

(6) That it is possible to trace anatomically the abductor and adductor fibres throughout the whole length of the recurrent laryngeal nerve to their termination in the one or other group of laryngeal muscles, and that these fibres appear to bear a fixed relationship to each other throughout their course, the abductors being situated on the inner side of the nerve or that next to the trachea, while the adductors are on the outer side.

(7) That it is possible to so accurately separate these two sets of fibres in the nerve trunk that excitation of either of them evokes contraction of the abductor or adductor muscles, as the case may be, without evoking any contraction whatever in the muscle or muscles of opposite function.

(8) That the bundle of nerve fibres concerned with one function may be divided without injury to that concerned with the opposite function, and that such division is followed by atrophy and degeneration of the muscles related to that function without any such changes being detectable in the muscles related to the opposite function.

Further, it is clear that the theory advanced by Mackenzie, and which has since found favour with many, viz. that possibly

the reason why the abductor fibres succumb before the adductor in affections of the nerve is because they are more superficially and circumferentially arranged, while the adductor fibres are situated deep in the substance of the nerve, is shown by these experiments to be entirely erroneous.

One point which is difficult to explain is why there should be so marked a difference between the recurrent laryngeal nerve of a young and that of an adult dog, as regards the respective predominance of abductor or adductor representation in the trunk of the nerve. Possibly the reason why the abductor influence is in the ascendancy in the young dog is because the power of phonation is still imperfectly developed, and with it both the muscle and nerve fibres subserving this function are also imperfectly developed, while the function of respiration is from the beginning fully developed, and with it the muscle and nerve fibres connected with that function. That the reverse should be the case in the adult animal may well be due to the fact that phonation is perfectly developed, while respiration has become so automatic that very feeble stimuli are necessary to keep it going.

“Interference with Icterus in Occluded Ductus Choledochus.” By Vaughan Harley, M.D.

This paper is one of considerable biological-pathological interest, as it gives an experimental explanation of the strange discovery made by Kufferath, in 1886, that by placing a ligature on the thoracic duct, the jaundice-producing effects of an occlusion of the common bile-duct could be instantly arrested—which fact Kufferath did not so much as even attempt to explain; and no other physiologist having either confirmed or negated the statement, far less offered any explanation of it, there were two problems requiring to be solved when Dr. Vaughan Harley entered upon the investigation:—

(1) Does ligaturing the thoracic duct actually prevent the jaundice which otherwise inevitably occurs after occlusion of the common bile-duct?

(2) If it does, how can such a remarkable phenomenon be explained? seeing that the chyle-transmitting thoracic duct has no apparent physiological connection with the ductus choledochus.

Kufferath only kept the animals he operated upon alive from 1 to 2½ hours—a period of time far too short to admit of any important morphological changes occurring, which could yield a clue to the mystery. Hence the first thing was to try and find a means of keeping the animals experimented upon alive for much longer periods of time, after both ducts had been ligatured. This was successfully done by feeding the dogs on fat-free food, containing only small proportions of proteids. It was found that when so fed dogs could not only be kept alive for weeks, but even months; and, what was stranger still, they even gained in weight.

The non-appearance of jaundice after ligature of the bile-duct when the chyle-duct was also tied, appeared remarkable from the fact that it was by all believed that both bile pigments and bile acids were always absorbed by the blood capillaries from the bile ducts; whereas it is now shown experimentally, in this paper by Dr. Vaughan Harley, that the blood capillaries have absolutely nothing whatever to do in the matter, and that, contrary to what has been up till now imagined, the pent-up bile is solely absorbed from the bile-ducts by lymphatics, and carried by them into the general circulation by the circuitous route of the thoracic duct.

Dr. Vaughan Harley has further demonstrated experimentally that, if a sufficient length of time is allowed to elapse after ligaturing the thoracic duct, bile pigment and bile acid again appear in the urine just as if the thoracic duct had not been ligatured at all, and that this arises from the fact that collateral lymphatics shoot out from the thoracic duct at a point below the ligature, and convey its contents into the right innominate vein. Hence he says that the three following conclusions may be drawn from the results obtained from his experiments:—

(1) That bile existing in the bile-ducts can only reach the blood through the intervention of the lymphatics.

(2) Seeing that lymphatics surround the liver blood-vessels, one is forced to believe that bile pigment and bile acid cannot pass through the endothelium of the blood capillaries in the liver; or, perhaps, even throughout the body. The fact that bile reaches the blood when it has escaped into the peritoneal cavity is no argument against this view. For in that case it reaches the blood through the lymphatics of the diaphragm.

(3) After the left thoracic duct of the dog has been ligatured for some time, collateral lymphatics are opened up or developed from it leading into the right innominate vein.

**Physical Society, March 25.**—Prof. S. P. Thompson, Vice-President, in the chair.—A note on the electromotive forces of gold and platinum cells was read by Prof. E. F. Herroun. Modern text-books put gold before platinum in Volta's electro-positive series, and thus one is led to expect a greater evolution of heat when gold combines with (say) chlorine, than when platinum does so. This, however, is not the case, for Julius Thomsen gives for the heat of formation of platonic chloride a value considerably greater than that for auric chloride. Gold should therefore be electro-negative to platinum. The few experimenters who have tested such cells, arrived at different conclusions, hence the author took up the subject, and examined experimentally the E.M.F.'s of zinc-platinum and zinc-gold cells, the metals being immersed in solutions of their chlorides of equal molecular strength. Instead of platonic chloride a solution of sodio platonic chloride was employed. From Thomsen's thermo-chemical data, the E.M.F. of such a zinc-platinum cell should be 1.548 volts, whilst experiment gave values between 1.70 and 1.473, according to the previous history of the cell. The average E.M.F. was about 1.525. Allowing the cell to send a current reduced the E.M.F. considerably, but it partly recovered on standing. Renewing the sodio-platonic chloride reproduced the high initial E.M.F. of 1.7 volts. This high value, and the uncertainty of the E.M.F. after sending a current, the author believed due to dissolved oxygen. Zinc-gold cells, the metals being immersed in solutions of their chlorides, gave more constant results, the maximum being 1.855, and the minimum 1.834 volts, whereas from thermo-chemical data the E.M.F. should be 2.044. On replacing a gold plate by a platinum one, the E.M.F. fell to 1.782. Other experiments showed that gold is slightly electro-positive to platinum in water or dilute HCl, but in aqua regia the positions are reversed. Prof. Ayrton said the experimental E.M.F.'s were fairly close to the theoretical values, and thought the differences might arise from occlusion of gases, which, although not taken into account in the thermo-chemical experiments, might have considerable effect on the electrical values. Platinum, especially, had remarkable occluding properties. Mr. Enright pointed out that, if any gases were disengaged by the reactions in the cells, their thermal values must be allowed for. The Chairman (Dr. Thompson) believed that some discrepancy between the calculated and observed values of the E.M.F.'s might be due to the calculations only being carried to the first degree of approximation. The complete expression contained, amongst others, a term depending on the temperature coefficient of the cell. On the subject of variation of the sign of E.M.F. with the strength of solutions, he said he had observed similar effects with cyanide solution. Dr. Herroun, in reply, said care was taken to expel as much of the occluded gas as possible before using the plates, and no gases were formed in the reactions. To Dr. Thompson he pointed out that Clark's cell had an E.M.F. greater than that calculated from thermo-chemical data, hence the temperature coefficient ought to be positive, but, as a matter of fact, it is negative. The discrepancy between the calculated E.M.F. and the observed he believed due to inaccurate determinations of the thermo-chemical constants of mercury salts.—A new instrument for showing the effects of persistence of vision was exhibited and described by Mr. E. Stuart Bruce. The instrument, which the author calls an "aerial graphoscope," consists of a narrow wooden lath mounted on a whirling machine, so as to be rotated rapidly in its own plane. The lath is tinted gray in the centre, and shades off to white at the ends. When rotated rapidly, it presents the appearance of a nearly uniform screen or disk, owing to persistence of impression. Ordinary lantern-slides were projected on this aerial screen with remarkable effect, for the pictures appeared suspended in mid-air. The author explained that the object of darkening the lath near the middle was to give a more uniform illumination to the picture or disk. On covering up the centre portion of the lath with white paper, the middle of a picture projected on it was much more strongly illuminated than the edges. Mr. Blakesley pointed out that the effect produced by darkening the centre of the lath might be attained by painting white sectors on a black lath.—A paper on some electrical instruments was read by Mr. R. W. Paul, and the apparatus exhibited. He first described a new form of standard ohm, the distinguishing feature of which is that the wire is wound in one flat spiral, and contained between two thin brass plates. The whole of the wire is thus practically at the same level in the water-bath, and therefore will be more likely to be at uniform temperature throughout than coils having considerable vertical depth. A

thermometer passing down the central tube has its bulb on the same level as the wire; and another thermometer, placed in the water-bath at the same level, serves to check the uniformity of temperature. In order that the width of the coil may not prevent convection currents in the bath, the screws which fix the two brass plates together have large holes through them. Dr. Fleming's suggestion of forming the upper ebonite insulator into an oil cup has also been carried out. A new form of Wheatstone bridge was next shown, possessing all the advantages of the dial pattern combined with great facilities for cleaning. There are four resistances in each proportional arm, and the adjustable arm has four sets of coils—units, tens, hundreds, and thousands—each set consisting of ten equal coils. The ends of each coil are connected to brass sockets, fixed, about an inch apart, on the ebonite top. Successive coils are put in circuit by placing a plug attached to a flexible cord in the required socket. Special contact-bars are provided, whereby two or more coils of any set of ten may be put in parallel arc, so as to get accurate resistances of large carrying capacity. These bars are also useful for obtaining high ratios between two resistances, a point of considerable importance in the testing of large resistances. Amongst the advantages claimed are: better insulation, avoidance of surface leakage by providing ample facilities for cleaning, small block error which is constant and easily measured, and no loose plugs required. Each set of ten coils may be used as separate circuits. By means of two travelling terminals the box may also be used as a potentiometer reading to 1 part in 10,000. A reflecting galvanometer with several improvements was then exhibited and described. The coil is supported on an ebonite pillar fixed to a tripod, below the centre of which controlling magnets on the Siemens principle are pivoted. The pillar gives good insulation from earth, and the adjustment of the control can be made without setting the needle in vibration. The two halves of the coil are wound according to Sir W. Thomson's law, and fixed in ebonite boxes turned to fit them. They are thus kept permanently in shape. The ebonite boxes are interchangeable, so that either high- or low-resistance coils can be used in the same stand. The coils have separate terminals, and can therefore be used in series or parallel or differentially. The mirror is placed in a metal box below the coils. When intended for an astatic instrument, magnets are put behind the mirror, and the metal box serves to damp the vibrations. For ballistic work the mirror has no magnets on it, and the damping may be regulated by sliding in or out a plug which carries the window of the mirror box. Mr. Swinburne inquired whether the plan of using two vertical magnets to form an astatic system had been tried, and with what result. He also asked if dial bridges made with switches instead of plugs would not be advantageous. Dr. Sumner said vertical needles had been used at the Central Institution, and found satisfactory. Mr. A. P. Trotter wished to know whether there was any very great advantage in designing galvanometers with a minimum amount of wire. A galvanometer was often required for many different purposes, and it did not follow that one with a minimum amount of wire was the best all-round instrument. Mr. C. W. S. Crawley made inquiries as to the magnitude of the block error in the form of Wheatstone bridge shown, for he thought the flexible cords would make it considerable. In reply to Mr. Swinburne, he said he had found the variations in switch bridges greater than in plugs. Prof. S. P. Thompson thought it was not generally known that the best shape of galvanometer coil depended on whether the instrument was to be used as an ammeter or voltmeter. The shape determined by Sir W. Thomson was a voltmeter coil; that for an ammeter was much shorter axially. Mr. Paul, in reply, said he used one or other shape of coil according to the use for which the galvanometer was intended. The block error in the Wheatstone bridge was very small, and quite negligible for most purposes. When very great accuracy was required, the error, being constant, was easily measured and allowed for.

**Royal Microscopical Society, March 16.**—Dr. R. Braithwaite, President, in the chair.—Mr. G. C. Karop exhibited and described Messrs. Swift's new fine adjustment to the substage. Mr. Karop stated that in this stage one complete revolution was equivalent to a vertical movement of  $\frac{1}{32}$  of an inch.—Mr. E. M. Nelson gave a *résumé* of the contents of two papers, the first of which was entitled "Virtual Images and Initial Magnifying Power," and the other "On Penetration in the Microscope."—Dr. W. H. Dallinger said that an important



communication had been received from Prof. Czapski, "On the Calculable Limit of Microscopic Vision." Its purpose was to show why it was that great numerical aperture was of such high value in the determination of minute structure, and to inquire whether—seeing that a numerical aperture of 1.60 was so utterly unavailable in the case of living objects, or of such as did not admit of being put into media of sufficiently high refractive index—there was any method of making these high numerical apertures available for such objects? The author had inquired into the value of monochromatic light for such a purpose, and the latter part of his paper was to show that by using the blue rays of such light with large apertures it was possible to increase the aperture so as to obtain the relatively great advantage which would result from a difference between 1.40 and 1.75. Mr. F. Crisp thought it should be pointed out that the broad fact dealt with in this paper was one which had long ago been explained. Dr. Dallinger said he had himself worked it out some time ago, obtaining as a result the difference between 1.40 and 1.70 which came remarkably near to that mentioned in the paper. Mr. Crisp said that the aperture table which was printed with every number of the Journal gave them the difference in resolving power between white light and monochromatic blue light with objectives of various apertures.—Prof. F. Jeffrey Bell gave an outline of the contents of a paper by Mr. H. L. Brevoort, entitled "Observations on the Brownian Movement," and pointed out that, whilst the general conclusion arrived at by the author was that light had some influence in the matter, he did not seem to have taken any precautions as to temperature, an element which was usually considered to be an active agent in this phenomenon.—A letter from the Hon. J. G. P. Vereker was read, replying to some points raised during the recent discussion of his paper "On the Resolution of *Podura* Scales."—Dr. A. C. Mercer read a paper on photomicrography as illustrated by a collection of seventy-three lantern-slides. Among the slides exhibited was a group which threw light on the vexed question of *Podura* scale structure. The author showed conclusively that the so-called featherlets on *Podura* scales are only inflections of the membrane. A number of slides also proved the value of the microscope as a means of detection in cases of forgery, or when alterations were alleged to have been made in promissory notes, the evidence afforded in one important case being very clearly demonstrated. A further group of slides was devoted to the illustration of the apparatus used in photomicrography. The President, in proposing a vote of thanks to Dr. Mercer, said he regarded the exhibition as the finest examples of what could be done by means of photomicrography.

**Entomological Society, March 23.**—Dr. D. Sharp, F.R.S., Vice-President, in the chair.—The Secretary read a letter from the City of London Entomological and Natural History Society on the subject of a proposed Catalogue of the Fauna of the London District.—Mr. G. C. Champion exhibited a number of new species of Longicornia from Mexico and Central America, recently described by the late Mr. H. W. Bates, in his paper entitled "Additions to the Longicornia of Mexico and Central America, with remarks on some previously recorded Species," read at the last meeting of the Society.—Mr. S. Stevens exhibited three very rare species of *Noctua*, viz. *Noctua flammatra*, *Leucania vitellina*, and *Lophygma exigua*, all taken by Mr. H. Rogers at Freshwater, Isle of Wight, in the autumn of 1891.—Mr. F. C. Adams again exhibited the specimen of *Telophorus rusticus*, in which the left mesothoracic leg consisted of three distinct femora, tibiae, and tarsi, originating from a single coxa, which he had shown at the meeting on the 24th of February last. The specimen was now reversed, to admit of the better examination of the structural peculiarities of the leg, upon which Dr. Sharp, Mr. Champion, and Mr. Jacoby made some remarks.—Mr. Osbert Salvin, F.R.S., exhibited a series of mounted specimens of the clasping organs in the male of several species of *Hesperidae*.—Dr. Sharp exhibited, for Mr. F. D. Godman, F.R.S., a collection of Orthoptera recently made in the Island of St. Vincent, West Indies, by Mr. H. H. Smith, the naturalist sent to that island by Mr. Godman in connection with the operations of the Committee appointed by the British Association and the Royal Society for the investigation of the Fauna and Flora of the Lesser Antilles. It was stated that the collection had recently been referred to, and reported on by, Herr C. Brunner von Wattenwyl and Prof. J. Redtenbacher.—Mr. J. W. Tutt exhibited and remarked on a series of various forms of *Orrhodia vaccinii* and *O. (spadicea) ligula*.—Mr. C. G. Barrett exhibited and made remarks on a

series of specimens—including some remarkable varieties—of *Bombyx quercus* and *Odomestis potatoria*. A long discussion ensued as to the probable causes of the variation exemplified, in which Mr. Tutt, Mr. E. B. Poulton, F.R.S., Mr. H. Goss, Mr. Jacoby, Mr. Salvin, F.R.S., Mr. Bethune-Baker, Dr. Sharp, and Mr. Distant took part.—Mr. G. A. J. Rothney sent for exhibition a number of specimens of *Camponotus compressus*, *C. micanus*, *Ceophila smaragdina*, *Sima rufo-nigra*, *Solenopsis geminata* var. *armata*, and other species of Ants, from Calcutta. He also communicated a short paper on the subject, entitled "Notes on certain species of Calcutta Ants and their habits of life."

## PARIS.

**Academy of Sciences, April 4.**—M. d'Abbadie in the chair.—Notice of the works of the late M. de Caligny, by M. J. Boussinesq.—On certain systems of equations with partial differentials, by M. Emile Picard.—Delivery from circular orifices, and reappearance between their different superficial elements, by M. J. Boussinesq.—On the native iron of Cañon Diablo, Arizona, by M. Mallard. The author has examined some specimens of native iron found in Arizona, the origin of which is doubtful. The iron contains only 3 per cent. of nickel, and when polished shows cavities filled with a black substance supposed to be iron carbide. In this comparatively soft substance a diamond, 0.5 mm. in diameter, was found by Prof. Koenig in 1890. The iron appears to be of meteoric origin, judging from its appearance. Mr. Foote has pointed out that the existence of a singular elevation, called Crater Mountain, near the place where large fragments of the material were found, may have something to do with their occurrence, but he has been unable to find any volcanic rocks in the neighbourhood. So the question of origin remains *sub judice*, and a critical examination of the region will have to be made before it can be settled.—On the spark spectra of gallium, by M. Lecoq de Boisbaudran. The spectrum given when sparks from a large induction coil play upon the surface of gallium chloride consists of two characteristic violet lines, and a wide, nebulous band in the green. If the same coil is used with a condenser and metallic gallium, a much more complex spectrum is obtained, and one from which the band in the green (wave-length = 502.33) is absent. The two lines in the violet (wave-lengths 417.04 and 403.19) are bright under both conditions of sparking. Substituting a small coil for the large one, M. Lecoq de Boisbaudran found that, besides the two violet lines, two others, at the approximate wave-lengths 641.24 and 639.23, were seen when no condenser was employed. On introducing the condenser, the latter line suffers a considerable diminution in intensity. Another line occurs at  $\lambda$  632.67, and a nebulous line about  $\lambda$  535.51. The wave-lengths and characters of all the lines observed under the three conditions are stated in detail.—On a method for the determination of the mechanical elements of helical propellers, by M. S. Drzewiecki.—Observations of Swift's comet ( $\alpha$  1892), made at the Paris Observatory with the West Tower equatorial, by M. G. Bigourdan. Observations for position were made on March 29, 30, 31, and April 1, 2, 3, 4.—The two asteroids discovered respectively by Wolf on March 28, and Charlois on April 1, were observed for position by Mlle. Klumpke, at the Paris Observatory, on March 31 and April 1 and 2.—Observations of Swift's comet (1892, March 6), made at Lyons Observatory, by M. G. Le Cadet. Position observations were made on March 31 and April 1.—On the indices of refraction of saline solutions, by M. Paul Bary.—New unipolar conductivity of gases, by M. Edouard Branly.—On the attraction between two disks separated by a dielectric, by M. Julien Léfwave. The author has measured the attraction between two electrified disks separated by a dielectric not in intimate contact with them, and finds it to be represented by the following formula:—

$$\frac{F'}{F^2} = \left( \frac{e + e'}{k + e'} \right)^2,$$

where  $F'$  equals the attraction stress between the plates at the distance  $e + e'$  in air;  $F$  the attraction at the same distance when a lamina whose dielectric constant is  $k$ , thickness  $e$ , and having parallel faces, is placed between the plates;  $e$  therefore represents the sum of the thickness of air between the lamina and the electrified disks.—On the production, in the dry way, of some anhydrous crystallized sulphates, by M. P. Klobb. (See Notes.)—On a nitroketone derived from camphor-sulphophenol, by M. P. Cazeneuve.—On the composition

of pinnaglobine, a new globulin, by M. A. B. Griffiths.—On the existence of parallel series in the biological cycle of Pemphigians, by M. Horvath.—The history of the *Garcinia* of the sub-group *Rhodiopsis*, by M. J. Vesque.—Researches on the variations in the transpiration of flowers during their development, by M. G. Curtel.—On some diseases of mushrooms, by M. Julien Costantin.—On the rôle, distribution, and direction of ocean currents in France during the Upper Cretaceous period, by M. Munier-Chalmas.—The tubercular vaccination of the dog, by MM. J. Héricourt and Ch. Richet. The authors' experiments indicate that, by the inoculation of tuberculosis *aviarie*, dogs can be vaccinated against human tuberculosis.—On a new pathogenic diplobacteria obtained from the blood and urine of influenza patients, by MM. Teissier, Roux, and Pittion.—Measures of the variations in the lengths of the Dauphiny glaciers, by Prince Roland Bonaparte. Of the sixteen glaciers whose movements were studied in 1890, six were found to be advancing, eight retreating, and two stationary. In 1891 the results obtained indicated that six glaciers were advancing, five retreating, and five stationary. The amounts of movement measured are given in the paper.

## BERLIN.

**Physiological Society, March 4.**—Prof. Munk, President, in the chair.—Prof. Zuntz spoke on Dr. Werigo's experiments respecting the influence of oxygen on the elimination of carbon dioxide by the lungs. When an animal breathed pure oxygen into one lung and simultaneously pure hydrogen into the other, Werigo found more carbon dioxide in the alveolar air of the oxygen-lung than in that of the hydrogen-lung, and hence concluded that oxygen furthers the escape of this gas. Prof. Zuntz, however, pointed out that the diffusion of carbon dioxide from the alveolar air into the contents of the cannule used for the introduction of the gases must be greater on the side supplied with hydrogen than on the other, and that hence less carbon dioxide must naturally be found in the alveolar air of the former than of the latter. The really important question whether the absorption of oxygen leads to an increased elimination of carbon dioxide has therefore not yet been answered. Werigo's experiments should be repeated, using oxygen and nitrogen.

**Meteorological Society, March 8.**—Prof. Schwalbe, President, in the chair.—Dr. Lachmann gave an account of a research on the extremes of temperature in Europe. He first assured himself of the trustworthiness of the readings of his maximum and minimum thermometers. He then determined for stations which afford prolonged series of data how many years must be taken into account in order to arrive at a trustworthy mean, and found that in the case, e.g., of Brussels, ten years suffice for the determination of its maximum temperature, whereas some forty years must be taken into account when determining its minimum temperature. After comparing the extremes of temperature with the periodic observations, he discussed the maximal and minimal temperatures met with in Europe, and gave an account of their geographical distribution. When those places with equal maxima are joined by lines, curves are obtained which on the whole resemble the July isothermals, and are the same as the latter if 12° be added to them. The curves of equal mean minimal temperatures correspond to the isothermals for January after subtracting 10°–11°.—Dr. Knorre read a letter containing an account of a thunderstorm on January 31, near Jüterbock, accompanied by hail and light phenomena, which must undoubtedly be regarded as a case of St. Elmo's fire.—Prof. Spörer exhibited photographs of the recent large sun-spot group which he observed between February 9 and 16, and which were most probably connected with the magnetic storm of the 13th and 14th of that month.

**Physical Society, March 11.**—Prof. Kundt, President, in the chair.—Dr. Staffp spoke on the increase in density of the interior of the earth, and deduced a mathematical formula for its determination.—Dr. Arons described experiments on the electrical polarization at the two sides of a metallic plate immersed in an electrolyte at right angles to the current. A platinum plate 0.1 mm. thick gave not only an evolution of gas but an increase of resistance, results which were entirely absent when a gold-beater's film was employed, as also with a film of silver. Pores in the metallic films were not the cause of the absence of polarization, since it appeared even when a small hole was bored in the above-mentioned platinum plate. When four gold-beater's films were superposed, they led to a slight increase of resistance and feeble polarization.—Dr. Rubens stated that he had extended his observations on the dispersion of the ultra-

red rays from w.l. 5.7  $\mu$  to w.l. 8  $\mu$ . He found that the curves for the index of refraction do not correspond with Langley's surmises. As far as w.l. 5.3  $\mu$  the curves of the two observers coincide, but the rectilinear course which the curve assumes at w.l. 5.0  $\mu$  is not persistent with light of greater wave-length; it tends to rise slightly from the line of abscissae. Hence Langley's interpolations for very long waves are inaccurate.

## AMSTERDAM.

**Royal Academy of Sciences, February 27.**—Prof. van de Sande Bakhuyzen in the chair.—Dr. Moll communicated some results he had obtained on the karyokinesis of Spirogyra. By embedding the threads in collodion and paraffin, and cutting them into series of sections with the microtome, he has observed a special organization in nucleolus and karyoplasma, leading to the formation of the chromatic segments; he has been able to establish with certainty the existence of the phenomenon of heteropoly in Spirogyra; and lastly, he has seen that Tangl's and Strasburger's *Verbindungschlauch* between the daughter-nuclei appears at an earlier stage in the form of some vacuoles, of which a single one finally prevails.—Mr. van der Waals treated of the phenomenon of incomplete mixture of two liquids, in those cases in which the mixture is complete at a higher temperature, and gave a formula founded on his "theory of a mixture of two substances," by which the volumes of a given weight of dissolved matter may be calculated in the same way as the volumes of liquid and vapour of a single substance.—Mr. van Bemmel treated of the difference of colloid oxides and crystalline hydrates, especially in reference to the oxide of iron. He demonstrated that only Brunck and Graebe have observed the crystalline hydrate of a definite composition. The substance prepared by Rousseau is not a crystalline hydrate, but ferrite of potassium, transformed by the action of water into amorphous hydratic oxide (of indefinite composition), and only pseudo-crystalline, as it has preserved externally the crystalline form of the ferrite.—Mr. Franchimont showed a sample of ethylaloxime (acetaldoxime), a beautiful crystallized body, melting at 48° C. The ethylaloxime, discovered in 1882 by V. Meyer, was described by him and by Petraezek as a fluid, boiling at 114°–115° C. The crystallized ethylaloxime has the same boiling-point, and may be a stereo-isomery.

## CONTENTS.

	PAGE
A Remarkable Book on the Habits of Animals. By Dr. Alfred R. Wallace	553
The Prevention of Influenza	556
Our Book Shelf:—	
Ratzel: "Anthropogeographie"	557
"Within an Hour of London Town: among Wild Birds and their Haunts"	557
Letters to the Editor:—	
Exchange of Professorial Duties.—Prof. E. Ray Lankester, F.R.S.; Prof. T. P. Anderson Stuart	557
Magnetic Storms.—Dr. M. A. Veeder	557
Pilchards.—J. T. Cunningham	558
Ornithology of the Sandwich Islands.—Albert F. Calvert	558
First Visible Colour of Incandescent Iron.—T. C. Porter	558
Self-Registering Weather-Cock.—J. Lawrence-Hamilton	559
The Rolling of Ships	559
Travels among the Great Andes of the Equator. (Illustrated.) By Prof. T. G. Bonney, F.R.S.	561
Science at the Royal Military Academy	563
The late Sir William Bowman. By Prof. J. Burdon Sanderson, F.R.S.	564
Notes	566
Our Astronomical Column:—	
Observations of the Spectrum of Nova Aurigæ	569
Denning's Comet ( <i>b</i> 1892)	569
Comet Swift, 1892	569
Displacement of Radiant Points	570
Two New Variables in Cepheus	570
On the Variation in Latitude	570
The Institution of Naval Architects	570
Fourth Annual Report of the Delegates of the Oxford University Museum	574
Societies and Academies	573

THURSDAY, APRIL 21, 1892.

## THE YAHGAN.

*Mission Scientifique de Cap Horn*. Tome VII. "Anthropologie, Ethnographie." Par P. Hyades et J. Deniker. (Paris : Gauthier-Villars et Fils, 1891.)

THIS volume contains the record of an important part of the work done by a French scientific Expedition which spent a year at Tierra del Fuego. The Expedition was organized in June 1882 by a Commission appointed by the Academy of Sciences ; and in November 1883, after its return to France, it presented to the Academy its preliminary reports. Since the latter date, its results have been embodied in a series of volumes, prepared under the control of the Commission, and published under the auspices of the Ministries of Marine and Public Instruction. The first volume contains a history of the voyage, by the late L. F. Martial, the Commander of the *Romanche*, in which the Expedition sailed. The second volume, by L. Lephy, is devoted to meteorology ; the third, by F. O. Le Cannellier, to terrestrial magnetism ; the fourth, by P. Hyades, to geology ; the fifth, by Hariot, Petit, Bescherelle, Massalongo, and Franchet, to botany. It was originally intended that zoology should also be dealt with in a single volume ; but the material obtained by the Expedition was so rich and of so much scientific importance that three volumes were found to be necessary. The present volume, nominally the seventh, is really the ninth, and completes the series. Although Dr. Deniker is associated with Dr. Hyades as one of the authors of this work, he did not accompany the Expedition. He has rendered, however, important service in the working-up of the anthropological and ethnographical data brought back from Cape Horn.

The book is one in which serious students of anthropology will find much to interest them. It offers a great mass of original observations, made, as Dr. Hyades explains, without any preconceived idea ; and they are not only arranged methodically, but set forth in a style of admirable simplicity and clearness. The volume is also enriched with numerous plates, some of which are finely-executed heliogravures.

The Fuegians are divided into three groups—the Ona, the Alakalouf, and the Yahgan. The Ona inhabit the great island of Tierra del Fuego from the southern coast of the Strait of Magellan to near the northern shore of Beagle Channel. They are probably a branch of the Patagonians, and the Expedition had no opportunity of seeing any of them. The islands and a part of the mainland to the west of the Ona are inhabited by the Alakalouf, to the south of whom are the Yahgan. These two peoples speak different languages, but seem to have essentially the same racial characteristics. It was among the Yahgan that Dr. Hyades carried on his studies, and to them the volume almost wholly relates.

The Expedition brought back the body of a Yahgan who died while the *Romanche* was at Orange Bay, and who during his lifetime had been subjected to various careful measurements. They also brought the skeleton of a woman and the skeletons of five children ; three skulls (two of men, one of a woman) ; two incomplete skeletons, and various detached bones. These remains

are made the subject of a thorough anatomical study which is the more valuable because the results at which the authors have arrived are compared with those reached by previous investigators. There is also an elaborate chapter on morphological characters, setting forth various classes of facts noted in the course of accurate observation of the physical qualities of living persons. The Yahgan are mesocephalic, the men having a tendency to be dolichocephalic, the women to be brachycephalic. Most of the South American aborigines are decidedly brachycephalic ; but here and there tribes are found whose skulls resemble those of the Yahgan. This is especially true of the Botocudos, who are also like the Yahgan in being rather below the average height of other natives, and in the form of the face, the nose, and the mouth. Various ancient skulls which have been found at Lagoa Santa in Brazil, at Pontimelo in the Argentine Republic, and elsewhere, have the same general structure as those of the Botocudos and the Yahgan. The authors therefore conclude that these and some other tribes are more or less pure remnants of a race which at one time occupied the greater part of South America, and were displaced by brachycephalic peoples, with whom the survivors to some extent mingled. Of these brachycephalic peoples, the Patagonians alone are very tall, the rest being of moderate height. All, however, whether tall or short, are of a different physical type from the Yahgan.

The Yahgan live chiefly on fish and mollusks. They also eat any kind of bird they can catch, and are fond of the flesh of the whale, the seal, and the otter. When pressed with hunger, they will eat the fox, but never dogs or rats, the latter being held in abhorrence. Fishing is left entirely to the women, while the men hunt. They have splendid powers of digestion, and assimilate their food so readily that they sometimes become fat in the course of a single day. Their huts are made of branches or of the trunks of trees, the interstices being imperfectly filled up with moss or bark, with fragments of canoes or with sealskin. These slight dwellings are put together in a few hours, and as they admit the wind freely, the air in them is generally fresh. In the centre is a fire, around which the inmates sleep at night, and at other times, when they have nothing else to do, sit talking and laughing. The Yahgan lose early the attributes of youth, but often retain their vigour to a great age. They are very courageous, and enjoy games which test their physical strength.

Among the women intimate friendships are not uncommon, but men generally form attachments to one another only if they have been brought up together. Children are tenderly cared for by their parents, who in return are treated by them with affection and deference. Some men have two or more wives, but monogamy is the rule. The girls do not choose their own husbands ; they must take those whom their parents provide for them. Before marriage they are allowed great liberty, but when they become wives they have less freedom, the husbands being extremely jealous, and being supported by public opinion in punishing severely any departure from conjugal duty. This account differs from that of some other observers, but Dr. Hyades is confident that his statements on the subject are strictly accurate. Both girls and mar-

ried women are remarkable for the modesty of their demeanour, and expect to be treated respectfully.

When the Yahgan approach a strange vessel in their canoes, they might be taken for abject beggars; but on shore visitors obtain a different impression. There the natives display perfect independence, and they readily take offence at anything which they interpret as a slight. They are far from having a community of goods, every man claiming as his own that which he himself has found or made; but they are of a generous disposition, and like to share their pleasures with others. That they have a sense of right and wrong Dr. Hyades does not doubt, but their moral distinctions are not always very sharply drawn. They are accomplished liars, and the only disadvantage of a lie seems to them to be that the truth is sometimes apt to be found out. A man convicted of theft, however, will show that he is ashamed of his deed; and murder is punished with death. The Yahgan have often been accused of cannibalism, but Dr. Hyades agrees with Mr. Bridges, who knows them thoroughly, in regarding this charge as utterly without foundation.

They can occupy themselves continuously for a considerable time with any employment to which they are accustomed, such as the making of a harpoon; but it is hard for them to devote attention to anything with which they are not familiar. When questioned on any subject, they soon become confused, and give answers at random. They do not divide time or count beyond three, and have remarkably short memories. But they are good observers of the signs of the weather, of plants, and of animals; and they have an extraordinary power of mimicking attitudes, gestures, and cries, although they have no such faculty of imitation as leads to the production of new instruments, utensils, or other useful objects. They are wholly unable to make anything, however simple, after a given model. They often have dreams, but do not generally appear to attach to them any significance. They have neither poetry, nor history, nor traditions; and Dr. Hyades asserts that the members of the Expedition never saw among them the faintest trace of religious ideas or sentiments. Those of them who are directly under the influence of English missionaries have learned to live regular lives, but have lost many aptitudes possessed by the savage Yahgan; and they easily fall victims to various forms of disease which have been imported with civilization.

The language of the Yahgan is dealt with in a long and most instructive chapter; and interesting details are given as to the occupations of the people, their domestic customs, and many other subjects. Of the plates, to which we have already referred, we need only say that they alone would have sufficed to make the work an invaluable contribution to ethnographical and anthropological science.

#### QUANTITATIVE ANALYSIS.

*Quantitative Chemical Analysis.* By Frank Clowes, D.Sc. Lond., and J. Bernard Coleman. Pp. 309. (London: J. and A. Churchill, 1891.)

THIS book embodies the material usually included in a complete course of elementary instruction in quantitative analysis. It is divided into five parts.

NO. 1173, VOL. 45]

Part I. treats of the balance, the determination of physical constants, the purification of substances, and preliminary analytical processes generally. The more important simple gravimetric estimations are grouped in Part II.; and are followed, in Part III., by descriptions of the methods and the more common determinations comprised under volumetric analysis. In Part IV. are classed more complex exercises, involving both gravimetric and volumetric processes. Here are to be found analyses of ores, technical products, fuel, articles of food and drink, including complete analyses of milk, butter, sugar, and partial analyses of wine, beer, and tea. The valuations of tannins and soaps are next given, and the part concludes with a section on the typical methods of organic analysis. Part V. is devoted to a description of the ordinary methods of technical gas analysis.

The above brief summary of contents will show that the aim of the volume is eminently practical; and with regard to the purely chemical sections little but praise can be expressed, both at the general and detailed treatment of the subject. All the more important estimations have been included, and the practical points to be observed in accurate work are clearly stated. A noteworthy feature, and one especially helpful to the student, is the brief statement of the principle of each estimation, in a sentence or two, before the detailed process is described. The accounts of food and gas analysis are both useful and interesting, and are seldom met with in manuals of this kind.

There can be no doubt but the book will be a serviceable guide to the student, and aid to the teacher.

One or two minor points, however, seem worthy of criticism. It is stated in the preface that, in order to economize space, "unnecessary theoretical matter" has been omitted, and apparently this idea has been carried too far. For example, it is but just to tell the student why in estimating sulphur as barium sulphate, nitric acid is first expelled. Knowledge of a similar kind, more especially in the physical portions of the book, is occasionally left out, and descriptions are thus rendered more or less empirical.

If it is considered necessary to give methods for determining specific gravities, boiling-points, &c., in a work of this kind, the accounts should be modern, and the accuracy aimed at should be comparable with that attained in the chemical sections. Absolute specific gravity—or shortly, specific gravity—as used in the book, with no temperatures of comparison attached, is now generally taken to be the weight of unit volume; such a definition is not hinted at, and none of the methods given serve to obtain the absolute specific gravity. The time-honoured but obsolete pycnometer, closed by a perforated stopper, still finds a place, and the original Sprengel pycnometer is figured, although it might well be replaced by Perkin's more generally useful modification.

With regard to the estimations of boiling-point, it should have been clearly stated that to take the barometric pressure was a necessary part of any trustworthy determination. In correcting for the exposed column of the thermometer, one of the more recent coefficients might have been given in place of the oldest and least satisfactory. What is supposed to be the mean tem-

perature of the cooled column is erroneously stated to be the temperature of the air. A little more detail, especially in connection with the suspension of the tube in Chapman Jones's boiling-point apparatus, would have been advisable.

Bunsen's method of calibrating a eudiometer is given, but none of the methods for utilizing the results to obtain the volume at any point is mentioned.

The indiscriminate use of both English and French units throughout the book does not seem to have any advantage; indeed, to give the dimensions of a tube as "1 millimetre in bore, . . . 8 inches in length," may be practically enough, but it is hardly scientific.

The meaning of expressions such as "water . . . drawn back . . . by the partial vacuum," "liquid" of a given "gravity," "ammonia condensed in hydrochloric acid," "the tension of aqueous vapour," might be conveyed in language free from objection.

The book is almost free from typographical errors; only two were noticed. On p. 227, cadmium sulphate is printed for cadmium sulphide, and the letter (a) should be replaced by (b) at the foot of p. 349.

The table of contents, referring to page and paragraph, and the index are particularly complete. A useful appendix giving results of typical analysis, constants for calculating results, &c., is added, and a list of works of reference is given in the introductions to the different parts. The relative importance of different estimations is indicated by difference in the type, and cross-references are frequently introduced. These points alone go a long way to indicate the pains taken by the authors to meet the wants of the student.

J. W. R.

### ASTRONOMY.

*Elementary Mathematical Astronomy.* By C. W. C. Barlow and G. H. Bryan. "University Correspondence College Tutorial Series." (London: W. B. Clive and Co., 1892)

THE task of writing a book on astronomy which shall enable a beginner to grasp all the fundamental principles and methods without entering into elaborate details of mathematics is by no means a light one. What the authors have done, and we may say very successfully too, has been to strike a mean between the numerous non-mathematical works and those which involve high mathematics, using just enough to enable the reader, if he wishes, to proceed to the more advanced treatises.

To simplify matters further, all investigations which require a knowledge of the elements of dynamics have been collated together at the end under the title of dynamical astronomy, thus separating them from those of descriptive astronomy, which only needs elementary geometry, trigonometry, and algebra. Some of the chief properties of the ellipse which are of astronomical importance are contained in the appendix, while for the properties of the sphere an introductory chapter has been inserted.

This summary will give an idea of the range over which the student will have to extend his mathematical abilities, and after all it is by no means an extensive one, considering the ground which this work covers.

In the chapter on the Observatory a very good account is given of the transit circle and its accompanying errors; but of course, without spherical trigonometry, many points of great importance with regard to the reduction of observations have had to be omitted. The chapters on the earth, sun's apparent motion and time, all contain lucid and concise explanations, which are well illustrated by figures showing the great circles involved. Many interesting problems are worked out in the chapters on the moon and eclipses, while that on the planets contains a good account of the stationary points in their apparent motion.

"The Distances of the Sun and Stars" is the title of the chapter that concludes the non-dynamical section, and in it the interesting problems on finding the parallax of the sun are discussed, together with the various results that ensue from the aberration of light.

Coming now to the second part of the book, the rotation of the earth and the resulting consequences are first dealt with, in which the proofs of the former are clearly described; while many problems relating to pendulum oscillations, variation of gravity at different places, &c., are fully expounded. The following two and concluding chapters are devoted wholly to the laws of universal gravitation, and to the multiple applications to which they are subjected. These chapters are perhaps the best in the volume, and contain, of course, some most important problems, such as the determination of the density of the earth, precession, tides, &c.

The examples and examination-papers, which are by no means few in number, will be found to be both original and well selected; and this is really important, for a sound knowledge of this subject can be obtained only by the continual practice of working them out.

In conclusion, we may state that altogether the work is one that is sure to find favour with students of astronomy, and will be found useful to those for whom it is especially intended. This is by no means the first volume that we have received which is published in this Tutorial Series, and the present work is a good example of the excellent text-books of which it is composed.

### OUR BOOK SHELF.

*Practical Fruit Culture.* By J. Cheal, F.R.H.S., Member of Fruit Committee, Royal Horticultural Society, &c. Illustrated. (London: George Bell and Sons, 1892.)

WITHIN the last few years farmers and others have often been advised to take to the cultivation of fruit, and there can be little doubt that much of the profit connected with fruit-growing—now absorbed by foreign traders—might, under certain conditions, be kept in the hands of our own people. The most important of these conditions is that persons who think of devoting attention to fruit culture shall obtain sound information about the work they propose to undertake, and that at all the later stages of their enterprise they shall act under the guidance of trustworthy authorities. In the present little volume, which forms one of Bell's "Agricultural Series," Mr. Cheal has brought together, and carefully arranged, a great many facts which cannot fail to be of service to intelligent fruit-growers. He begins with a chapter on the general prospects of culture for profit. Then come chapters on the selection of soil and situation, the preparation of the

ground, what to plant, planting, pruning, cost and returns per acre, the renovating of old orchards, gathering, packing and distributing, storing and preserving, grafting, budding, and stocks. These chapters form the first part of the book. The second part consists of counsels on various subjects to private growers, and in the third the author deals with insect pests and disease. The work is essentially practical, and will tend to stimulate the development of what ought to become a more and more important British industry.

*Blowpipe Analysis.* By J. Landauer. Authorized English Edition. By James Taylor. Second Edition. (London: Macmillan and Co., 1892.)

DR. LANDAUER'S work presents so much sound knowledge in so compact a form that the fact of the English version of it having reached a second edition is in no way surprising. The text, we are informed in the preface, has been completely revised, and new methods of approved value have been incorporated. The author and the translator call especial attention to the fact that some additional details of manipulation will be found of value by readers who are working up the subject without a teacher.

#### LETTERS TO THE EDITOR.

[The Editor does not hold himself responsible for opinions expressed by his correspondents. Neither can he undertake to return, or to correspond with the writers of, rejected manuscripts intended for this or any other part of NATURE. No notice is taken of anonymous communications.]

##### Prehistory of Egypt.

THE evidences of denudation are so striking in the ravines of the Egyptian deserts, that I make the following notes, hoping that some trained geologist will be induced to do more for the subject. The successive periods which I have noted are as follows:—

(1) *Rainfall*, before much excavation of the Nile bed; producing an enormous river with rolled gravels and blocks up to 3 feet long. It is unlikely that this was merely a beach, as the gravels extend for many miles north and south; nor would it be estuarine, as the flow must have been rapid. The only parts of these beds that I have seen are on the tops of the hills dividing the Nile from the Fayum, which are entirely composed of these gravels. The great mass of these beds has been denuded away by the later Nile and rainfall, leaving these ridges 200–300 feet above the present Nile.

(2) *Rainfall and elevation.* All over the desert plateau of limestone, the strata of which are usually horizontal, there are sharp depressions and faults. These are usually of small area, a quarter to half a mile across, with a drop of over 200 feet. The strata are at the same level, and horizontal, on the opposite sides of these depressions, but are steeply curved and faulted down into the hollows. The only cause seems to be the falling in of immense caverns in the limestone, for there is no trace of thrust or upward folding anywhere. Such caverns must have been produced by great rainfall, and high elevation to allow of the water draining off at so low a level, below that of the present Nile.

(3) *Disturbances.* It is impossible to suppose that the great gravel beds of the Nile in period (1) were deposited along the steep edge of a basin 400–500 feet deeper; hence the deep Fayum basin must have been depressed (as it can scarcely have been eroded) subsequently to the period (1), and probably during the same disturbances which shook down the strata into the caverns of (2).

(4) *Great rainfall and elevation continued*, during which the present Nile bed has been eroded, and the ravines graved out in its sides, reaching back for many miles through solid rock. This was subsequent to (3), as the ravines were partly determined by the subsidences, and have cut through them. This was a long period to allow of 200–300 feet of rock to be cut out of the Nile bed. The elevation was probably the same as in (3), as the rock bed of the Nile is at a great depth under deposits in Lower

Egypt. The rainfall was violent, as the sides of narrow ridges of rock, which cannot have collected much, are grooved into deep flutings all along; and the waterfalls from basins of only one or two square miles, are wide and steeply cut.

(5) *Rainfall, and depression forming an estuary.* Up to about 300 feet above the present Nile, remains of perfectly horizontal beds of *débris* may be found clinging to the sides of the ravines, which must be subaqueous deposits. In front of each of the ravines are foot-hills of *débris*, evidently washed out of the ravines, and deposited in an estuary. There cannot have been much current in the main valley, as these foot-hills extend sometimes two miles outward; yet there was some current, as they are always on the lower side. This appears to be in the human age, from the rolled river palæolith which I found at Esneh, and which cannot have belonged to a later time. These estuarine beds occur as far up as Tel el-Amarna or further.

(6) *Rainfall, gradual and intermittent elevation*, leaving various levels of foot-hills in the estuary. To this belong the chipped flints of the *débris* beds in front of the ravine of the kings at Thebes, as man was probably inhabiting that valley, for these to have been washed out of it. The rainfall continued until the estuary was completely dried, as the watercourses have cut down to the present Nile level. Nile mud began to be brought down and deposited while the water was yet 30 feet above the present, either as a river or estuary.

(7) *Complete desiccation*, throughout the historic age. The roads marked out with stones on the plain at Tel el-Amarna in 1400 B.C. are only destroyed in the very lowest lines of the watercourses. The ancient buildings in Egypt only show the effects of rare storms, and not of continued rain. The mud deposits throughout this age are at an average rate of 4 inches per century in the old bed of the Nile.

The sequence described here seems to be tolerably clear, though much more detail needs to be filled in as yet.

W. M. FLINDERS PETRIE.

##### Aphanapteryx in the New Zealand Region.

I SENT you a short note some weeks ago announcing the discovery of a species of the Mauritian genus *Aphanapteryx*—which I had named *Aphanapteryx hawkinsi*—in the Chatham Islands. I have just returned thence from a visit made expressly for the purpose of searching for further remains of this bird, of which I received at first only the cranium. I have been very fortunate in my search, and have procured several most perfect crania, with tibiae and femora, which I have no doubt belong to the same bird, as more than once I discovered these bones in the immediate neighbourhood of the crania. The bones have been disinterred from the lower beds of a sandbank facing the shore. Some years ago, a great storm, followed, as I am told, by a tidal wave of great height, broke the Eurymia-protected shore bluff; and now the wind, having carried off the upper bed of light-coloured sand into the lands behind, is continually planing down more and more the brown lower bed in which these bones seem mostly to be entombed. They are in a most perfect state of preservation, and very complete, though deprived of all their animal matter. Of the *Aphanapteryx* crania some are considerably larger and some much smaller than *A. Brocketi*, the larger reaching to within  $\frac{1}{16}$  inch of 6 inches from the top of the slender arched upper mandible to the occiput. The tibiae and femora vary in size corresponding to the differences in the crania; but they present the main characters of the bones figured by M. Milne-Edwards in his "Oiseaux fossiles de la France." It may yet turn out that more than one species of *Aphanapteryx* inhabited the Chatham Islands. It is very singular that, among the thousands of bones that have been collected from different swamps, Maori middens, and caves in various parts of New Zealand, not a single bone of this bird should have come to light. In one refuse heap from a Moriori feast laid bare by the wind on the beach of Petre Bay, I found several specimens of *Aphanapteryx hawkinsi*, along with crania and other bones of ducks, swan, sea-birds, seals, whales, &c. Swan-bones were everywhere very abundant in this brown sand bed; some of them indicating birds equal in size to *Chenopsis atrata*, others considerably exceeding it. In one very ancient midden the remains I dug up consisted almost entirely of swan-bones, with the intermixture of only a few duck-bones. The *Aphanapteryx* must, I think, be the wingless bird spoken of by the Morioris as *Mehiriki*, although those to whom the skull has been

shown fail to recognize the bird at all. They speak also of another flightless bird by the name of *Melunui*. This bird, one old and very intelligent Moriori informed me, was the same as the Maoris called *Kakapo*. Mr. Alexander Shand, an old resident in the Chatham Islands, and the sole European living versed in Moriori customs and traditions, and capable of speaking their language with fluency, also confirmed this information, and told me that the *Kakapo* (according to the Morioris) was very abundant in the islands prior to 1836. He himself in the early days had seen their burrows often. I had observed, while collecting, several Psittacine bones, and on learning this fact I felt sure that those I had picked up and packed away must belong to *Stringops*. On my arrival here, however, I find so far that there are no *Kakapo* bones in the collection, the Psittacine bones being the head and beaks of *Nestor notabilis*, the Kea. I have as yet had time to do no more than run through the collection I have brought back; but there appear to be in it several large Ralline tibiae of species unknown to me. I am looking forward to another opportunity of thoroughly exploring these interesting islands with more time at my disposal than I could afford on this occasion. HENRY O. FORBES.

Canterbury Museum, February 23.

### Pigments of Lepidoptera.

A LETTER of mine on the subject of butterfly pigments was published so recently in NATURE (December 31, 1891, p. 197) that I hesitate to ask for further space at the present time. But the appearance of Mr. Perry Coste's articles, together with the tone of some remarks made by him at the close of the last article, lead me to venture upon a few words, partly in criticism of a theory he advances, and partly (though this is less important) in claim of priority, since Mr. Coste does not do me the honour to refer to my work on the subject.

The chief generalization which Mr. Coste bases upon his experiments is that which he terms the "reversion effect,"—that is to say, the production of yellows from reds by the action of acids, and the restoration of the former by neutralization and other means. The theory that he advances to explain these phenomena—namely, that the red body acts as a base, and forms with acids salts which are yellow—is quite untenable. As I have shown (Proceedings of the Chemical Society, June 1889; vide NATURE, vol. xl, p. 335), the soluble yellows are themselves acid bodies of quite definite composition. Indeed, as far back as 1871, Prof. Meldola called attention to the fact that the pigment of *G. rhamnii* was soluble in water, and showed that its aqueous solution had an acid reaction. Mr. Coste has worked with *D. eucharis*; if he will dissolve the red pigment from the border of the hind wing of this insect in pure water, he will find that a yellow solution is the result, but that, if the solution be evaporated to dryness, the solid residue of pigment is red once more; showing that there is either the question of hydration to consider, or a weak combination of the yellow acid body with a base, which is dissociated in aqueous solution. At any rate, I have obtained from this red pigment of *eucharis* a silver compound which contains a percentage of metal exactly equal to that from the pigment of *G. rhamnii*.

In 1889 I was able to predict possible constitutional formulae for the acid yellow pigments, and am happy to say that recent careful combustions of their silver salts to a large extent confirm my original ideas. My results will be shortly published in *extenso*.

Mr. Perry Coste's experiments are very useful as forming a method of classifying these lepidopterous pigments; but, if he will forgive me for saying so, they are of far too empirical a nature for any considerations as to the constitution of the bodies to be based upon them. As one who has for many years past spent a large portion of his time and no inconsiderable portion of his substance in obtaining a sufficiency of these pigments for analysis and investigation, Mr. Coste will forgive me if I do not respond to his invitation to leave him "to continue his researches alone." It is hardly well for one investigator to say "hands off" to another, and I shall not imitate Mr. Coste in this matter; but will only express a hope that in his future work he will not confine himself to the immersion of the wings of his insects in strong and destructive reagents.

I have lately been working at the genesis of these pigments in the pupæ, and might say something with regard to the nature of

the group which Mr. Coste labels as doubtfully pigmentary; but for the present I have sufficiently trespassed upon your space.

F. GOWLAND HOPKINS,  
Guy's Hospital, S.E., April 9. Gull Research Student.

### "C.G.S. System of Units."

THE new edition of Prof. Everett's "C.G.S. System of Units" contains, at the very beginning, two misleading statements, based seemingly on a misapprehension of facts. In so valuable a work, such errors are to be deplored.

Pp. xiii. and xiv. give an account of weighings made at the International Bureau of Weights and Measures between certain "standard pounds" and the international standard of mass.

From the statement as given, it would be inferred that there is room for doubt as to the relation between the British standard of mass and the international kilogramme.

The real facts are, that the standard pounds were only nominally "pounds"; they were standards with known corrections, which, however, have not been applied to the equivalents given on p. xiv.

The true relation of the Imperial pound to the international kilogramme is given in the Board of Trade Report of Proceedings under the Weights and Measures Act, 1884 (p. 4), according to which the Imperial pound = 453.5924277 grammes.

On p. 34 of "C.G.S. System of Units," Mr. Chaney's results of the weight of a cubic inch of water are discussed, and the conclusion is reached that Mr. Chaney's result differs by 0.00125 from the theoretical relation between volume and mass of water in the metric system.

This result is obtained by comparing Mr. Chaney's results, without reduction to *vacuo*, with the mass of a cubic centimetre of water.

Mr. Chaney states that the standard air to which his result is reduced weighs 0.3077 grains per cubic inch. Therefore his result reduced to *vacuo* is: one cubic inch of water at 62° F. weighs 252.286 + 0.308 = 252.594 grains.

If we take the value for the thermal expansion of water, in terms of the hydrogen thermometer scale, as determined at the International Bureau, we find the density of water at 16° 667 C., = 62° F., referred to its maximum density = 0.998861.

Using the equivalents 1 metre = 39.3700 inches, and 1 gramme = 15.43235639 grains, we obtain: one cubic inch of water at 62° F. weighs in *vacuo* 252.6045 grains; while Mr. Chaney found 252.594 as above given, a discrepancy of one part in 25,000 only, as compared with one part in 800, given by Prof. Everett. It is not clear from Mr. Chaney's statement whether his weight in air is against brass or other weights; therefore the vacuum reduction above applied is uncertain by a small amount.

O. H. TITTMANN.

Washington, D.C., March 10.

MR. TITTMANN thinks the true relation is, without doubt—

1 pound = 453.5924277 grammes.

Prof. W. H. Miller determined it to be—

1 pound = 453.59265 grammes,

which is the value given on the Card of Equivalents published by the Board of Trade. If the determination quoted by Mr. Tittmann from a Board of Trade Report of 1884 was made under such conditions as to render it authoritative, it is a pity it has been allowed to remain for eight years buried in a Blue-book. One would have expected some intimation of it to be given to scientific men through the Royal Society or in the pages of NATURE.

As regards the three "standard pounds" which were compared with standards at the Bureau International in 1883, Mr. Tittmann says they had known corrections. This is not stated in the *Travaux et Mémoires*, where the account of the comparison is given. There is, however, in the case of the two which are of gilded bronze, a reference to a description of them by Prof. Miller in his paper on the standard pound (Phil. Trans. 1856), and, on turning to it, I find that their errors, as stated by him, do not agree even approximately with the determinations made at the Bureau. They differ even in the first significant figure of the error, which is the sixth figure of the entire value; so that, as far as this evidence goes, the five figures 45359 are all that are certain.

As regards the other matter referred to, Mr. Tittmann does not mention the publication in which "Mr. Chaney states that the standard air to which his result is reduced weighs 0.3077 grains per cubic inch." The only publication known to me is Mr. Chaney's paper in the Proceedings of the Royal Society, and it does not contain any such statement.

I have always been taught to regard a standard weight as a standard of mass, and therefore independent of such conditions as temperature, pressure, and the material in the other scale pan; whereas, it appears that Mr. Chaney, by direction of the Board of Trade, has made a determination which is only true for a particular density of the surrounding air, and a particular density of the weights in the other pan.

For scientific purposes a standard of reference should be free from variable elements, and should be of the utmost attainable simplicity. For commercial purposes determinations, to six figures are frivolous.

Mr. Tittmann's reductions appear to contain two errors. Instead of adding the weight of a cubic inch of air, he ought to have added the difference between this and the weight of the air displaced by the weights in the opposite pan. Again, he takes the metre as 39.3700 inches, whereas Clarke's value is 39.370432, and Kater's 39.37079.

I have had some correspondence with Mr. Chaney since the publication of my new edition, and have had an erratum slip printed, which I trust you will allow me to subjoin, as it may be useful to several of your readers J. D. EVERETT.

5 Princess Gardens, Belfast, March 28.

#### Addenda and Corrigenda.

Page 63. In reducing Cailletet's experiments, '0000026 should have been added instead of '0000039.

Page 77. Add—Violle's determination of velocity of sound is  $331.10 \pm 0.1$ . *Ann. de Chim. XIX, March, 1890.*

Page 176, line 10. For Wuilleumeir, 1890, read Wuilleumier, 1890, Lippmann method.

At end of page 164, add—Expressing  $C$  in amperes,  $R$  in ohms, and  $T$  in seconds, the heating effect in gramme-degrees is  $C^2RT/42 = .24C^2RT$ .

Page 35. Mr. Chaney's determination here quoted was not intended as a determination of the density of water, but of the apparent weight of water when weighed in air of density '00121684 against brass weights of density 8.143. The correcting factor for deducing the weight *in vacuo* or true density is 1.0010687, which will change the value '998752 obtained in the text into '99982, to compare with Tralles' '99988.

Mr. Chaney's result is for distilled water deprived of air, and Tralles' appears to be for ordinary distilled water. According to results recently obtained by the Vienna Standards Commission (*Wied. Ann.*, 1891, Part 9, p. 171), water deprived of air has the greater density, the difference being '000032 at 0° C., and '000017 at 62° F. These differences are too small to affect the above comparison.

#### Influenza in America.

In my copy of "Johnson's Dictionary of the English Language in Miniature, to which are added an alphabetical account of the heathen deities and a copious chronological table of remarkable events, discoveries, and inventions, by the Rev. Joseph Hamilton, M.A., second American edition, Boston, 1806" (12mo, pp. 276), I find on p. 275, "Influenza in North America, 1647, 1655, 1697-98, 1732, 1737, 1747, 1756-57, 1761, 1772, 1781, 1789-90, 1802."

It is quite possible that these dates are well known, but they are new to me, and may be of interest in connection with the recent epidemic.

EDWARD S. HOLDEN.

Mount Hamilton, March 29.

#### DUST COUNTING ON BEN NEVIS.

WITHIN the last few years quite a new factor has been introduced into the study of meteorology—namely, that which treats of the dust particles in the atmosphere, of the number of dust particles present in the air at any time, and the effect of dust in the air on climate and weather changes. It is now beginning to be recognized that the study of dust and its behaviour in the air forms the stepping-stone to the study of almost all

meteorological problems which deal with clouds and precipitation, solar and terrestrial radiation, and in a general way with the diurnal and annual variations in the temperature and pressure of the atmosphere. Mr. Aitken's work in originating this branch of science, and in making and discussing numerous observations of the number of dust particles in the air of various places in this country, as well as on the Continent, at various altitudes, is pretty well known already (see NATURE, vol. xii. p. 394). Mr. Aitken's results and conclusions were looked upon as being of such importance as to warrant some of our leading meteorologists to apply to the Research Fund of the Royal Society for a grant to enable them to equip the Ben Nevis Observatory with Aitken's dust-counting apparatus. The application was successful, and instruments were at once ordered, and in due time erected at the Observatory.

The apparatus consists of two dust counters, one a portable form for use in the open air, and the other a laboratory form for use inside the Observatory. The latter is fixed in the middle room of the tower, and has pipes leading out to the free air, so that it is possible to observe with it in almost all sorts of weather and at any hour day or night. The principle on which these instruments are constructed, so as to make the tiny invisible particles of dust visible and easily countable, is pretty well known already. Briefly it is this. To make the particles visible, the air containing them is saturated with water vapour, and by a stroke of an air-pump it is thereafter cooled so much as to cause a condensation of the vapour on the particles, whereby these are thus made visible. Ordinary air is so dusty that if the receiver were full of such air it would be impossible to count the particles, and to make them easily countable the following process is resorted to. First, the chamber or receiver, whose capacity is accurately known, is filled with pure dustless air by means of an air-pump and filter. Then a fifth, a tenth, or any other fractional part of the amount of pure air inside is taken out, and the same amount of dusty air allowed in. In this way the density of the shower caused by condensation is completely under the observer's control. A small graduated stage is placed one centimetre from the top of the receiver, so that all the dust above this falls on to it, and by means of a magnifying glass all the particles on one or more of the small squares of the stage are easily counted. Then, by multiplying by the reciprocals of the various fractions used we arrive at the number of dust particles in a unit of the free dusty air. In making an observation, the mean of ten such tests is taken as the number of particles present for that time.

Observations were begun at the Ben Nevis Observatory with the portable instrument in February 1890, and with the other instrument in the following summer. During the whole of that year the work done was mainly preliminary, as great difficulty was experienced in getting the dust work to fit into the general routine of Observatory work. The dust inquiry is not like some other special inquiries, that can be prosecuted for a certain time, and then discontinued after definite positive or negative conclusions thereon have been arrived at, but must, on the other hand, be carried on side by side with the other observations of meteorological phenomena, as pressure, temperature, humidity, &c., with any of which it is of equal importance, and having once been admitted into the general routine of meteorological observations it must be kept on. This fact was soon seen on Ben Nevis from the extraordinary variations that were observed in the dustness of the air with changes of weather; and it was attempted to make continuous hourly observations of the dust as of the other elements. It was found, however, that this could not be done without crippling the general routine, this being as much as the two observers at the Observatory could well cope with. In February 1891



a system of three-hourly observations of the dust particles was started, and this has been kept up with but few interruptions since. The dust observation is made immediately after the usual hourly set is completed, and it can thus be studied along with all the other hourly records in their relation to the prevailing weather.

A great many observations have in this way been accumulated during the past two years, but we have not had time for studying them in detail yet. A mere inspection, however, brings out some interesting points. One of these is the enormous variation that is observed in the number of dust particles, not only in the course of the year, but often in the course of a few hours. At sea-level the number of dust particles in the air at any time depends very much on the locality and on the wind, whether blowing from a polluted district or not. The mean of a number of observations made by Mr. Aitken at Kingairloch, in the west of Scotland, is 1600 particles per cubic centimetre. In London, on the other hand, he found 100,000 per cubic centimetre, and in Paris rather more. On Ben Nevis the mean is 696 per cubic centimetre, the maximum being 14,400 per cubic centimetre, and on several occasions the minimum fell to 0. A general mean does not convey a fair idea of the dustiness of the air at the mountain-top, although it may do so for places at sea-level, because there is at the former place a great daily range in the number of dust particles, depending on the rise and fall of the air past the place of observation. If there is any marked variation at sea-level it is entirely of a different character. Below are the means, as well as the maxima and minima, of all the months that have a fairly representative number of observations.

Number of Dust Particles per cubic centimetre on Ben Nevis.

1890-91.	Feb.	Mar.	April.	May.	June.	July.	Aug.	Nov.
Means . .	(1,585)	1,037	2,300	1,757	(790)	(588)	(666)	418
Maxima . .	6,350	12,862	14,400	4,940	3,850	4,000	1,286	3,150
Minima . .	4	0	11	4	50	0	67	12

The above table shows that the Ben Nevis air contains most dust in spring, and it is probable that sea-level air is in this respect similar; the cause of this greater amount of dust in spring than at any other time of the year being the great annual westward motion of the whole atmosphere, or at least of a considerable depth of it, at that time of the year. In a recent paper on "The Winds of Ben Nevis" (Trans. R.S.E., vol. xxvi. p. 537), it has been shown that this is one of the very few points in which the high- and low-level winds agree, viz. in the excess of easterly winds in spring. The above means for summer are probably too low, as that summer was exceptionally cold, and the general circulation was very abnormal, and that in the direction which would tend to give low dust values. The maximum, 14,400, was observed at 1 p.m. on April 11, 1891; and, as an instance of how very much the values change in a short time, at 8 a.m. that morning the number was only 350 per cubic centimetre, and by midnight it had again fallen to 600 per cubic centimetre.

The daily variation is fairly well indicated from the three-hourly observations. For the months of March, April, and May, 1891, the following are the means for the eight hours of observation:—

Number per cubic centimetre.

Hour.	1	4	7	10	13	16	19	22	Day.
Means . .	736	526	570	551	950	1438	1035	1029	854
Difference from mean—									
Above . .	...	...	...	...	96	584	181	175	...
Below . .	118	328	284	303	...	...	...	...	...

<sup>1</sup> Bracketed values are for 1890 only.

Here there is a minimum indicated (526) at 4 a.m., and a maximum (1438) at 4 p.m. All the forenoon values are below the mean, and the evening values above it. It would appear that during the forenoon the summit of Ben Nevis is above the first or lowest cloud or dust stratum. About noon this stratum rises to the level of the summit, and during the afternoon hovers above it, and falls again late at night. From this it might be inferred that the summit is oftener clear of cloud in the early morning, and oftener enveloped in the afternoon. A table showing the number of times the top was clear during the last seven years shows that only about 30 per cent. is clear weather in which the summit is free from fog; but it does not show a daily variation as indicated by the dust values, what little it does show being quite the reverse—namely, a maximum of clear weather in the middle of the day and a minimum at night. This clearly indicates that when the dust layer falls below the summit at night, radiation at once forms an independent cap on the hill-top; and again in the afternoon, although the dust stratum envelops the summit, the opposite radiation warms it up and prevents condensation, or rather evaporates the watery particles of the cloud. So that, contrary to public opinion, the best time to visit the summit for the sake of the "view" is the middle of the day, and not the early morning. During fine settled weather the rise and fall of this cloud stratum can be followed, but in average weather the effect of radiation completely masks it. The effect of solar radiation and nocturnal radiation on dust, as particles and as strata, is a problem that has to be studied and worked out. Very little is definitely known about it at present.

In the study of the nature and motions of clouds the dust observations will be of great value. When a fog envelops the summit, the number of dust particles observed may vary greatly without any apparent change in the thickness of the fog, but as a rule dry thick fog contains a great amount of dust, while thin wet mist contains very little. It is when a thin drizzling mist envelops the summit that the lowest values are always obtained, and then there is a distinct difference between the conditions at sea-level and those at the summit, the winds at the latter place differing in direction by 90° or more from the winds below, and sometimes the upper winds are blowing straight out from the centre of a shallow low-pressure area, and the dust that rises with the slight ascending currents of the lower strata is almost entirely filtered out before reaching a height of 4400 feet. One of Mr. Aitken's conclusions may briefly be put as follows: Much wind, little dust; much dust, little wind. That dust seems to accumulate in the quietest places is fully borne out by the Ben Nevis observations. This is true not only horizontally, but also vertically, and it seems probable that this is what chiefly determines the position of cloud strata at all heights. And from this we may infer that the motion of clouds is much slower than that of the general aerial currents; and again, since clouds tend to form between currents, and may have as direction of motion the resultant of the directions of these currents, it follows that as indices to the motions of the upper air the velocity and motion of clouds are very unsatisfactory.

Observations of the apparent haziness of the atmosphere are made whenever it is possible, and the relations between the haziness of the air, the humidity, and the number of dust particles, have been found to be the same as what Mr. Aitken pointed out. Briefly, he found that with a constant humidity the haziness increased or diminished with the number of dust particles, and with a constant number of dust particles the haziness depended on the humidity (at least when the air was within 10 or 15 per cent. of saturation); for with increase of humidity the air became thicker, because apparently condensation begins on the dust particles before the air reaches its point of saturation.

The dust observations promise to be of special value in the study of weather types. In some weather types, not only are the dust values very abnormal, but the daily variation is in some instances quite abnormal also, indicating that the cloud or dust strata are differently situated from what they are in average weather, and also that their daily rise and fall occur at different times. In March 1890, the dust values show this very well: below are the three-hourly means for each of three different periods:—

Hour per cubic centi- metre . .	First Period (12 days).							
	1	4	7	10	13	16	19	22
	78	61	78	67	113	408	258	102
	Second Period (3 days).							
„	2867	1785	917	4733	4213	4295	3417	2533
	Third Period (5 days).							
„	65	25	37	19	20	28	93	76

During the third period of five days the weather was very remarkable. A large depression was slowly progressing eastwards to the north of Scotland, and the winds on Ben Nevis were blowing almost straight out from the centre, while the winds at sea-level were circulating in the normal direction. This is the usual type when low dust values are obtained; but it is difficult to quite account for the daily variation in the dust values being reversed, the higher values occurring at night, and the lower in the middle of the day. This and many other points have not been studied yet.

Dr. Buchan, in his recently published work on "Atmospheric Circulation," hinges his explanations of various atmospheric phenomena on the effect of solar and nocturnal radiation on the dust in the atmosphere, and accounts it one of the most important factors in the study of modern meteorology. The observations made at Ben Nevis Observatory clearly show that for observing the number of dust particles in the air, with a view to the observations being applied to the study of atmospheric phenomena, a true peak is of all places the best, because we can study not only the horizontal distribution of dust as brought by the different winds, but also, to a certain extent, the vertical distribution by the ascending and descending motions of the air past the place of observation.

ANGUS RANKIN.

ABSTRACT OF MR. A. RICCO'S ACCOUNT OF THE SUBMARINE ERUPTION NORTH-WEST OF PANTELLERIA, OCTOBER 1891.<sup>1</sup>

OF what happens in submarine eruptions we naturally know little. The evidence of Graham's Island (1831)<sup>2</sup> and the eruption of Pantelleria (1891), to the south of Sicily, and of the damaged telegraph cables and various surface phenomena<sup>3</sup> to the north, towards the Lipari Isles, shows us that such eruptions are not rare in the Sicilian district, and any records of these fleeting occurrences that we can get, in the way of observation and specimens, may well prove of increasing interest as others are obtained to compare with them.

Mr. A. Ricco has recently published<sup>1</sup> a detailed and illustrated account of the facts he was able to gather, concerning last October's submarine eruption north-west of Pantelleria, either in person or from local and other observers, he having reached the island during the latter part of the eruption. From this, at the suggestion of

<sup>1</sup> *Annali dell' Ufficio centrale Meteorologico e Geodinamico*, ser. ii., Parte 3, vol. xi.

<sup>2</sup> (a) Lyell's "Principles of Geology"; and (b), for Bibliography, Johnston-Lavis's "South Italian Volcanoes," pp. 105-107.

<sup>3</sup> (a) "South Italian Volcanoes," pp. 63 and 65; and (b) Giov. Platania, "I Fenomeni Sottomarini durante l'Eruzione di Vulcano (Eolie) nel 1888-1889," *Att. Rend. Acc. Sc. Let. Art. Acireale*, n. ser., vol. i., 1889, pp. 16, tables 3.

Prof. Judd, who has kindly sent me a copy, I extract the following:—

Pantelleria, an island (13½ by 8 kilometres), situated between Sicily and Tunis, is entirely of volcanic origin.<sup>1</sup> The volcanic activity would at present appear to be a shade less marked than in the "Phlegæan Fields," west of Naples.

In Pantelleria we have exhalations of CO<sub>2</sub>; hot springs (of which those at the lake called "Bagno del Acqua," among other things are, we are told, so rich in alkalis as to lather, and be used for washing clothes!), and fumaroles, some of which exhale steam harmless to vegetation, and with little if any specific effect on the rocks, while others give out sulphurous vapours at 88° C. or more, decomposing the rocks about them.

There is but doubtful record of seismic disturbances in the island prior to the summer of 1890. Then, however, earthquakes occurred, with elevation of part of the north coast, the cracking of cisterns, and an increase in the number and activity of the fumaroles, so that vineyards formed in some of the old craters were damaged. After more than a year's interval, earthquakes again commenced October 14, 1891 (three days before the eruption). These were accompanied by drying up of certain springs, and apparently a further rise on the north coast, with surface cracks in that district.

As the shocks were most violent and vertical at the little town of Pantelleria itself (at the end of the island nearest the scene of eruption), they caused considerable consternation; and if one went by the account of the overstrung inhabitants, who felt shocks not recognized by the seismoscopes, one might exaggerate their violence. On the other hand, the walls of the houses, which outside the town have frequently no upper story, are, on the whole, substantially built, so that the insignificant damage done is perhaps hardly a gauge. Part of the north coast (Fig. 1) appears to have been raised, in the two years,

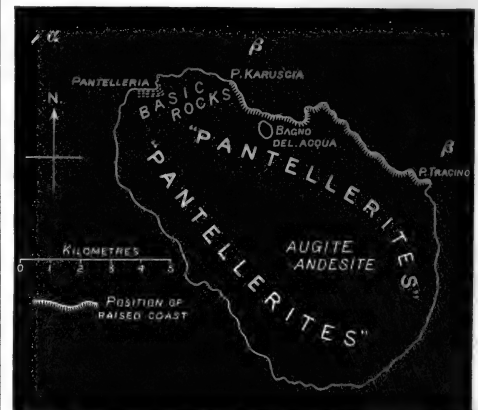

FIG. 1.—Map of Pantelleria, showing the position, according to Ricco, of (a) the submarine eruption of October 1891, and (b, β) of the raised coast.

some 80 cm., the old sea-level being marked by a line of white incrustations; and we are told that, according to a recent estimate,<sup>2</sup> the tide in this part of the Mediterranean has an amplitude of but some 8 cm.; besides, there was the evidence of inhabitants who had bathed, boated, and fished along the coast. The submarine eruption (4 kilometres north-west of the island, Fig. 1) began on

<sup>1</sup> Foerster, "Nota preliminare sulla Geologia dell' Isola di Pantelleria" (with geological map), *Boll. Com. Geol. d'Ital.*, 1881.

<sup>2</sup> Prof. G. Grabovitz, "Le isorache della marea nel Mediterraneo," *Rendiconti della R. Accad. dei Lincei*, 16 Agosto, 1891.

October 17, 1891, when the earthquakes abated, and water returned to some of the wells. The appearance of the sea, as viewed from the land, at first suggested the presence of some "great fish," and columns of "smoke" were seen. Those who visited the spot later (Fig. 2) found black

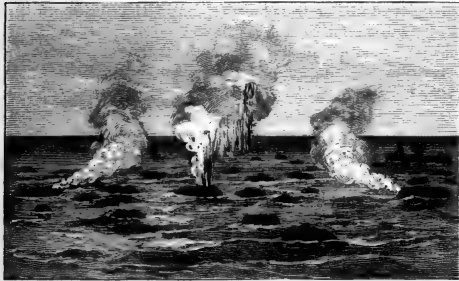

FIG. 2.—Part of a sketch of the submarine eruption near Pantelleria, October 1891. (After Ricco.)

scoriaceous bombs rising to the surface, along a line some 1 kilometre in length, extending north-east and south-west, which might well indicate a submarine fissure, the activity being specially great at certain points. Some of the bombs discharging steam ran hissing over the water with the recoil. Many were still very hot inside, fusing zinc (415° C.), and one was red-hot (in daylight), but below 800° C. Some pieces were thrown 20 m. in the air, as I gather, not so much by their momentum on reaching the surface as by the explosions occurring there. After the explosions the fragments sank, the material having a sp. gr. of about 2.4. The highest temperature of the water obtained was but 1½° C. above that of the surrounding sea. Ricco now questions the trustworthiness of the soundings made at the scene of eruption to a depth of 350 m. without feeling bottom, and he was told that fishermen had previously found but 160m. of water there. Though some saw bubbles rise to the surface, the gases usually emitted in the case of subaerial eruptions were not detected in the sample of water collected, which Ricco suggests may be due to their having been taken into solution by the water lower down. However, there was a smell "as of gunpowder" at the spot; and the dark, basic, spongy matter of the bombs (previously described), "the only solid material erupted," gives out when heated a sulphurous odour, a fact of which Mr. F. Chapman had previously informed me. The eruption terminated on October 25, and the erupted matter disappeared.

I should add, in conclusion, that I have ascertained from Dr. Errera, who has charge of the seismological apparatus on the island, that the telegrams published in an English daily paper, as to renewed eruptions in the neighbourhood at a later date, were quite without foundation.

G. W. BUTLER.

March 22.

GIRAFFES.

THE Zoological Society of London, as our readers know, have lost their last remaining Giraffe, and, for the first time since 1836, no example of this, one of the most wonderful of living Mammals, is to be seen in the Regent's Park Gardens. Nor does it seem likely that the loss can be easily restored. At the present time, owing to the Mahdists having closed the Soudan to trade, the Giraffe-market is very poorly supplied. Only one specimen of this animal, we are told, is for sale in

Europe, and an exorbitant price is naturally asked for it. In South Africa the Giraffe is practically extinct, being only still met with in a few isolated localities nearly a thousand miles from Cape Town. In East Africa there are still Giraffes, and in places nearer the sea-board; but here, apparently, there are no means of catching them alive, as the natives do not understand how to do it. Here, however, it is that there appears to be most likelihood of obtaining a fresh supply. This will be an expensive business, but unless some steps are soon taken in the matter it seems that the younger generation of England will grow up without knowing what a living Giraffe is like. Their parents have been more fortunate. From the list given below, it will be seen that there have been 30 individuals of the Giraffe exhibited in the Zoological Society's Gardens since 1836, of which 17 have been born there, and 13 acquired by purchase. Of these 30, one was presented to the Royal Zoological Society of Ireland in 1844, five have been sold at prices varying from £450 to £150, and the remainder have died in the Gardens.

List of Giraffes that have lived in the Society's Gardens.

No.	Sex.	How obtained.	How disposed of.
1	♀	Imported May 24, 1836.	Died Oct. 15, 1852.
2	♂	Do. do.	" " 29, 1846.
3	♂	Do. do.	" Jan. 14, 1849.
4	♂	Do. do.	" Jan. 6, 1837.
5	♂	Born in the Menagerie, June 19, 1839.	" June 28, 1839.
6	♂	Do. do. May 24, 1841.	Presented to the Dublin Zoological Society, June 14, 1844.
7	♂	Do. do. Feb. 25, 1844.	Died Dec. 30, 1853.
8	♂	Do. do. April 22, 1846.	" Jan. 22, 1867.
9	♂	Do. do. Feb. 12, 1849.	Sold April 27, 1850.
10	♀	Imported June 29, 1849.	Died Nov. 3, 1856.
11	♀	Do. do.	Sold Oct. 29, 1853.
12	♂	Born in the Menagerie, March 30, 1852.	" March 29, 1853.
13	♀	Do. do. April 25, 1853.	Died May 21, 1872.
14	♀	Do. do. May 7, 1855.	" Nov. 6, 1866.
15	♀	Do. do. July 16, 1859.	" Dec. 2, 1859.
16	♀	Do. do. May 26, 1861.	Sold May 1, 1863.
17	♂	Do. do. Oct. 7, 1861.	Died Dec. 18, 1861.
18	♂	Do. do. May 8, 1863.	" Nov. 18, 1863.
19	♂	Do. do. Sept. 24, 1863.	" April 21, 1864.
20	♂	Do. do. Mar. 31, 1865.	" April 3, 1865.
21	♀	Do. do. April 20, 1865.	Sold May 31, 1866.
22	♂	Do. do. Sept. 14, 1866.	Died Nov. 6, 1866.
23	♂	Do. do. Mar. 17, 1867.	" June 20, 1881.
24	♀	Purchased July 23, 1867.	" Sept. 12, 1869.
25	♂	Do. Jan. 5, 1871.	" April 27, 1874.
26	♀	Do. Oct. 11, 1871.	" May 21, 1878.
27	♂	Do. July 25, 1874.	" Jan. 8, 1879.
28	♀	Do. do.	" July 9, 1886.
29	♀	Do. do.	" Nov. 24, 1891.
30	♂	[Do. Jan. 27, 1879.	" March 22, 1892.

NOTES.

THE ordinary general meeting of the Institution of Mechanical Engineers will be held on Thursday evening, May 5, and Friday evening, May 6, at 25 Great George Street, Westminster. The chair will be taken at half-past seven p.m. on each evening, by the President, Dr. William Anderson, F.R.S. The President will deliver his inaugural address on Thursday evening, after which the following papers will be read and discussed, as far as time permits:—Research Committee on Marine-Engine Trials: Report upon trial of the steamer *Ville de Douvres*, by Prof. Alexander E. W. Kennedy, F.R.S., Chairman (Thursday, and discussion continued on Friday). On condensation in steam-

1 NATURE, vol. xiv p. 251.

engine cylinders during admission, by Lieut.-Colonel Thomas English, of Jarrow (Friday). The anniversary dinner will take place on Wednesday evening, May 4.

THE Royal Academy of Sciences of Lisbon has elected Sir Joseph Fayer, F.R.S., as a foreign corresponding member in the class of mathematical, physical, and natural sciences.

DR. R. THORNE THORNE, F.R.S., as was expected, has been appointed principal Medical Officer of the Local Government Board, in succession to Sir George Buchanan, F.R.S.

WE regret to have to record the death of Miss Amelia B. Edwards. She died on Friday last at Weston-super-Mare. Miss Edwards had done much both in England and in America to awaken public interest in the results of archaeological research in Egypt. She also did excellent service by her work in connection with the organization and control of the Egypt Exploration Fund.

MR. J. CARRUTHERS, son of Mr. W. Carruthers, head of the Botanical Department of the British Museum, has been appointed Lecturer in Botany at the College of Agriculture, Downton, for the coming summer. Mr. J. Carruthers has for some time been Demonstrator in Botany at the Royal Veterinary College, London.

AN International Economic Congress will be held at Antwerp in August next.

MR. W. CLAYTON PICKERSGILL, H.B.M. Vice-Consul at Antananarivo, who has just returned to England on leave, has brought with him a nearly perfect egg of the extinct gigantic Bird of Madagascar, *Epyornis maximus*. This was obtained, like all other previous specimens, from the southern coast of the island, near Cape Ste. Marie. Mr. Slater will exhibit the egg at the next meeting of the Zoological Society, on May 3.

ALL collections of plants received at the Royal Gardens, Kew, are examined, and reports upon them are sent to the donors. When of sufficient magnitude and importance, they are made, as in the case of the late Colonel Grant's collections in Central Africa, the subject of a detailed memoir. Anything of sufficient interest in smaller collections is illustrated with a plate in "Hooker's Icones Plantarum." Novelties which are not important enough to justify a plate have hitherto been relegated to their proper places in the Herbarium, where they have awaited description by some monographer. Collectors, however, are best encouraged when they see that the result of their labours supplies some tangible addition to scientific knowledge; so it has been decided that all plants received at Kew of which the novelty can be ascertained with some certainty shall be described for the information of botanists, and distinguished by formal names. Successive decades of plant-descriptions are to be published in the *Kew Bulletin*. The first decade appears in the April number, and suffices to indicate that the series will be one of great interest and value.

BESIDES the first of the "Decades Kewenses," the April number of the *Kew Bulletin* contains sections on Fiji ginger, the agricultural resources of Zanzibar, and the botanical station, St. Vincent.

WE learn from the *Kew Bulletin* that among the botanical treasures which have lately reached the Royal Gardens, is a second small collection of dried plants, sent by the Rev. R. B. Comins from the Solomon Islands. It includes several highly interesting things. Specially interesting among these are flowering specimens, though not perfect, of the tree that bears the so-called turtle-seeds of the islanders. This tree belongs to the *Sapotaceae*, and will shortly be published as a new genus of that order by Mr. W. B. Hemsley. The seeds are one of the most singular productions in the vegetable kingdom, and the

name given to them by the natives of the Solomon Islands is quite appropriate, as the resemblance is most striking. Mr. Comins collected seeds of what appears to be a second species of the genus, and Kew previously possessed a seed and foliage of a third species, collected in the Fiji Islands in 1878 by Mr. Horne, the Director of the Botanic Garden of Mauritius. There are also seeds of one or two other species in the Museum, where they have been for some years, but their origin is unknown. The *Bulletin* also calls attention to another very curious plant collected by Mr. Comins—*Lasianthera papuana*—in which the originally three-celled ovary develops into a fruit with one fertile, dry, woody cell, the two empty cells forming a fleshy body on one side of it.

IT is expected that the Borough Road Polytechnic Institute will be opened in October next. When the ceremony has taken place, two of the three Polytechnics for South London, for which Mr. Evan Spicer and his committee first appealed in 1888, will be at work. The Goldsmiths' Company's Institute at New Cross, which by the munificence of that Company was opened in October last, has considerably over 4000 members on its books. The third Polytechnic, that at Battersea, is in a fair way towards completion, and will, it is hoped, be opened in October 1893.

PROF. T. G. BONNEY, F.R.S., will on Tuesday next, April 26, begin a course of two lectures at the Royal Institution, on "The Sculpturing of Britain: its later stages"; and on Thursday, April 28, Prof. Dewar, F.R.S., will begin a course of four lectures on "The Chemistry of Gases." The Friday evening meetings will be resumed on April 29, when Dr. Benjamin W. Richardson will deliver a discourse on "The Physiology of Dreams."

MR. ALFRED W. BENNETT will deliver a course of lectures on systematic botany at the Medical School, St. Thomas's Hospital, on Tuesday and Wednesday mornings at 10 a.m., beginning Tuesday, May 3.

DR. SYMES THOMPSON will deliver at Gresham College, on April 26, 27, 28, and 29, a course of lectures on "The Eye in Health and Disease." The lectures are to be illustrated by diagrams, and will begin each evening at six o'clock.

ACCORDING to a Reuter's telegram, despatched from New York on Monday, two severe shocks of earthquake were felt at Portland, Oregon, at two o'clock on Sunday afternoon, and at various places in the vicinity. Numbers of buildings trembled, and so great was the alarm that people rushed panic-stricken into the streets. The vibrations were from west to east, lasting ten seconds in each case. No damage was done, and as the seismic disturbances were confined to two sharp shocks within a brief interval of each other, a feeling of confidence gradually returned.

SNOWSTORMS of exceptional severity have passed over the country during the last week, and in many parts of the kingdom the fall was heavier than at any time during the past winter. In Scotland, and over the northern parts of England, snow had been falling heavily on several days, and on Good Friday a shallow cyclonic storm area was approaching our south-west coasts from off the Atlantic, which occasioned heavy snowstorms in the Channel Islands and south-west of England. The central area of this disturbance passed up the English Channel and over the north of France, accompanied by an unusually heavy fall of snow over the south and south-east of England. The ground was covered in places to the depth of several inches, and the storm caused considerable damage to the telegraph wires in the southern parts of the kingdom. The night frosts were also very severe, the shade thermometer registering as low as 20° in places.

THE Report of the Kew Committee of the Royal Society for fourteen months ending December 31 last gives an account of

the observational and experimental work of the Observatory. The curves of the magnetographs have shown a marked increased activity in terrestrial magnetic changes as compared with the previous year, although no very large disturbances have been registered. The telegraph has been maintained in action during the greater portion of the year, but the instrument has failed in sensibility, owing to the diminished potential of the chloride of silver battery. The subject of the measurement of atmospheric electricity is consequently far from settlement. Sketches of sun-spots were made on 170 days, and the groups numbered after Schwabe's method. Two new forms of anemometer have been under trial: (1) the anemo-cinematograph of MM. Richard Frères, similar to that employed at the top of the Eiffel Tower—the vanes, by running constantly against a train of clock-work, record directly on a sheet of paper the velocity of the wind at any moment; (2) the Munro sight-indicating anemometer is a sensitive Robinson cup arrangement, which drives, by means of a small centrifugal pump, a column of oil up a glass tube. The instrument, as fitted at present, fails to work during frost, owing to congelation of the oil employed. Great activity continues to be shown in the verification department, over 20,500 instruments of all kinds having been tested; more than three-fourths of these were clinical thermometers. In the rating of watches, the highest position was attained by Messrs. Stauffer, Son, and Co., one of whose watches obtained a total of 91.6 marks out of a possible 100. Special circulars have been addressed to the directors of steamship companies, calling attention to arrangements made for the rating of chronometers. A special camera, capable of working with lenses of 4 inches aperture and 30 inches focal length, has been fitted up at the Observatory, for the examination of photographic lenses. A photometer, on Captain Abney's principle, 13 feet long, has also been fitted for use in the testing operations. The Committee have come to the conclusion that it would be of advantage to them to obtain registration under Section 23 of the Companies Act, 1867.

WE have received from the Deutsche Seewarte, (1) the *Deutsches meteorologisches Jahrbuch* for 1890, containing observations taken three times daily at nine stations of the second order, with monthly and yearly results, hourly observations and means at Hamburg and Wustrow, and extracts from the registers kept at the signal stations, on stormy days. The materials are similar to those published in former years, the only change being in the reduction of the number of stations for which observations from self-registering instruments are given. (2) *Ergebnisse der meteorologischen Beobachtungen* for the lustrum 1886-90, on the same plan as those previously published for the years 1876-80 and 1881-85. These publications extend over fifteen years, and form a very valuable contribution to the climatology of Northern Germany, affording ample data for investigations referring to individual hours, or days, together with an easy means of obtaining the combined results and the extreme values for the whole period over which the observations extend.

THE Washington Weather Bureau has just issued an atlas of thirty-six charts, being one of a series of useful works partially prepared under the superintendence of General A. W. Greely, Chief Signal Officer of the United States, prior to the transfer of the Meteorological Service. The charts show the average direction and hourly velocity of the wind at 8 a.m. and 8 p.m. (Washington time), at sixty-five representative stations, with the average maximum and minimum hourly velocity, and other interesting details, from observations for a number of years. The prevailing wind direction, and the direction next in order of frequency, are shown by arrows which fly with the wind, while figures set against the arrows indicate the percentage of

times the wind has been observed in the direction indicated by the arrows. General Greely remarks that the diurnal variation of the wind in the United States has not been investigated to any considerable extent, so that but little is known of its tendency except in a general way. It may be said, however, that in the northern hemisphere there is a well-defined tendency to veer a little in the morning, and to back through the same circumference in the afternoon. This inclination, however, is early subordinated to the influence of pressure changes and distribution, and cannot be detected except in settled weather.

WRITING in the American journal *Electricity*, on electricity in the United States Navy, Mr. W. B. Lefroy Hamilton refers to the working of the search light. He says that in the practical use of the search light, it has been found that in order to afford sufficient time for a careful examination of the water's surface, at points far removed from the ship, the beam of light must be revolved very slowly, and in consequence, during a great portion of the time any particular section of water is left in darkness. As it only takes five minutes for a torpedo boat to run a distance of two miles, it will be easily seen that in the interval between two successive illuminations of the same spot, a torpedo might attack a warship and discharge her deadly weapon. To overcome this difficulty, it is proposed that the new American war-ships, beginning with the *New York*, shall be fitted with a number of stationary search lights grouped together, each illuminating its own section, thus keeping the ship surrounded by an unbroken circle of light.

THE leather industry is to have a separate building at the Chicago Exhibition. Representatives of the industry have accepted a site offered them, and will erect, at an expense of 100,000 dollars, a building, measuring 150 by 600 feet, in which they will show an almost endless array of leather products, and every process in their manufacture from the raw hide to the most finished article.

THE latest annual report of the Hon. Edgar Dewdney, Superintendent of Indian Affairs in Canada, gives much interesting information as to the aborigines of the Dominion. They are distributed thus:—Ontario, 17,915; Quebec, 13,361; Nova Scotia, 2076; New Brunswick, 1521; Prince Edward Island, 314; Manitoba and North-West Territories, 25,195; Peace River district, 2038; Athabasca district, 8000; Mackenzie River district, 7000; Eastern Rupert's Land, 4016; Canadian Labrador, 1000; Arctic coast, 4000; British Columbia, 35,202—total, 121,638. The number of children of school age is 13,420, of whom 7574 are in attendance. Even in the North-West, where the conditions are harder than in British Columbia, great progress has been made. The property owned by the Manitoban and North-Western Indians includes 5599 houses and 2018 barns; 13,549 acres of land under cultivation, with 2115 acres newly broken; 1251 ploughs, 773 harrows, 899 waggons, 48 fanning mills, and 5 threshing mills; 2928 cows, 70 bulls, 2064 oxen, 4823 calves, 5879 horses, 428 sheep, and 215 pigs. Last year the North-Western Indians reaped a harvest including 67,726 bushels of wheat, 21,592 of oats, 19,761 of barley, 44,284 of potatoes, 14,788 of turnips, 1340 of carrots, and 413 of rye. The farm instructors and their wives make a point of teaching the Indians how to use their spare time. The men are encouraged to make handles for axes and hay forks, besides sleighs, ox collars, harness, brooms, &c. The women are initiated in tanning and butter-making, and already make articles of clothing that would not disgrace a white woman, being particularly quick at knitting; some of them, too, are expert in the manufacture of baskets, mats, and hats. The housing of the people also improves, the Indians in particular now partitioning their houses into rooms. The trust funds held for the Indians by the Government now amount to £703,046, and £57,098 was spent from this source last year, besides £186,442 voted by

Parliament. Of the Parliamentary grant no less than £164,437 went to the North-West, including Manitoba and Keewatin; while British Columbia took £17,010 of the remainder.

THERE seems to be no doubt that the aborigines of the Andaman Islands are rapidly disappearing. According to the latest administrative report relating to the islands, all the people of Rutland Island and Port Campbell are dead, and few remain in the South Andamans. Mr. Portman thinks that the present generation of this interesting race will be the last. Only a small number of children are born, and they do not survive infancy.

IN his Presidential address to the American National Geographic Society, now printed in the Society's Magazine, Mr. Gardiner G. Hubbard presents an interesting sketch of the forces which have been at work in the evolution of commerce. In the concluding passage he glances at what he supposes to be the future of commerce. America, the last of the continents to be inhabited, now receives, he points out, the wealth of Asia on the one hand and manufactures and population from Europe on the other. "Here the East and West, different from each other in mental power and civilization, will meet, each alone incomplete, each essential to the fullest and most symmetrical development of the other. Here will be the great banking and commercial houses of the world, the centre of business, wealth, and population."

IN ancient times Greece possessed something like seven and a half millions of acres of dense forest, and she was comparatively rich in timber until half a century ago. Many forests have now disappeared, and the result is seen both in the scarcity of the water supply and in various injurious climatic effects. The Austro-Hungarian Consul at Athens—while calling attention to these facts in a recent report, of which some account is given in the *Board of Trade Journal* for April—points out that even at the present day Greece possesses about two millions of acres of forest land. The quantities (in cubic metres) of timber and forest produce obtained in 1890, compared with 1889, were: building wood, 59,948 and 48,986; timber for shipbuilding, 2606 and 1640; for tools and machinery, 4146 and 2940; lignite, 509,895 metric centners, compared with 466,953; asbestos, 491,722 metric centners, compared with 490,179; and tanners' tawing materials, 20,003 metric centners, compared with 30,089 in 1889. Notwithstanding this considerable production, Greece will have to import large quantities of timber in the near future, so as to meet the demand arising from the revival of the building trades now affecting both the rural and urban districts of the peninsula.

A PAPER on the agricultural needs of India, by Dr. J. Augustus Voelcker, was read the other evening before the Society of Arts, and is printed in the current number of the Society's Journal. It gave rise to an instructive discussion, in the course of which Mr. Thiselton-Dyer—referring to the necessity of India producing sufficient food for its growing population—said the real question was how to get more nitrogen into the soil. That overshadowed everything else. He agreed with Prof. Wallace, who had spoken before him, as to one way of supplying this want. After the studies made in Germany, France, and England, there could be no longer any doubt that the growing of leguminous crops did enrich the soil with nitrogen in a way which, as far as was at present known, without manure, could be done in no other way; but in India the method of green soiling was not altogether unknown. If it were, the sooner some popular account of the method was distributed the better. An old pupil of his own, who had charge for a time of an experimental farm at Bangalore, found that by making some slight addition to the Indian plough he was able to stir the soil—not to plough

deeply, but to stir it lower than the ordinary plough did, and, by slightly opening the subsoil in this way, the roots were able to get down lower, and the crops, even in a season of drought, flourished in a way they did not when the soil was cultivated in the ordinary manner. He was inclined to think that the Indian plough was a thing which deserved a good deal of study; but it could not be studied very well by people in Europe, because our conditions were so different. The study should be made on the spot, and efforts should be made to improve the agricultural methods there by the introduction, if possible, of some kind of rotation with leguminous crops. He was under the impression that, in a great deal of the cultivated land of India, there was something like a pan, formed at no great distance below the surface, which made it extremely difficult for the roots to penetrate, and so they were unable to bear even a slight drought.

THE Great Bower Bird seems to give the people of Northern Queensland very frequent occasion to think about him. Every kind of fruit suffers from his depredations; and, according to a letter from Mr. E. M. Cornwall, printed in the *Victoria Naturalist*, he has also a taste for new-laid eggs. Says Mr. Cornwall:—"This is not mere supposition, but hard fact, for after noticing the disappearance of eggs in a most unaccountable manner for some time, the gardener kept watch, and was rewarded by seeing Mr. Bower Bird fly straight to a nest just vacated by a hen and deliberately pick the egg and polish off its contents." "*In re* the Great Bower Bird.—Since writing you last, I have had still further evidence to convict this rogue of what I charged him with. A bird was seen to fly right to a hen's nest in an empty shed and immediately emerge with an egg in his long claws; but the egg proved an awkward burden, and he dropped it ere he had gone many yards."

COLONEL W. S. HORE gives in the journal of the Bombay Natural History Society (vol. vi., No. 3) an interesting account of the taming of a heron. Writing from Deesa in September 1891, he says that during the then recent monsoon a young egret or heron with a greenish-brown neck and body, white-tipped wings, and green legs, flew into the verandah of his house, apparently in search of food. He caught it, and for about ten days kept it under a large basket, feeding it with raw meat. He then gave it its liberty, but it refused to leave. It grew very tame, and would feed out of Colonel Hore's hand. Occasionally it would indulge in a bath in one of the dog's tins, and afterwards sit on a chair in the verandah. In the evening it flew away to roost in one of the large neem trees in the compound. It showed no fear of the dogs, and would give any of them who came too near a vigorous "dig" with its long bill. It remained with Colonel Hore for about six weeks, when, as his regiment was under orders to march, and he was afraid if left behind it would meet with an untimely end, he carried it down to the river about two miles off and left it there.

THE new number of *Petermann's Mitteilungen* has a map of the Kalahari Desert, and the western part of British Bechuanaland, with remarks by Edward Wilkinson. There are also articles on the Pamir question (with map), by F. Immanuel, and contributions to our knowledge of the south-eastern part of Persia, by A. J. Ceyn.

THE Rochester Academy of Science, U.S., has published two brochures of the first volume of its Proceedings. The papers are attractively printed and well illustrated. Among the contributions we may note, "The Aurora," "The Forces concerned in the Development of Storms," and "The Zodiacal Light," by M. A. Veeder; "Description of New Meteorites," and "Notice of a New Meteorite from Louisa County, Va.," by Edwin E. Howell; "Root Foods of the Seneca Indians," by G. H. Harris; "Descriptions of New Species of Muricidae, with remarks on the apices of certain forms," by Frank C.

Baker; and "Notes on Mexican Archaeology," by F. W. Warner.

MESSRS. WM. BLACKWOOD AND SONS will publish, in the course of a few days, a short treatise on "Farmyard Manure," by Mr. C. M. Aikman, Lecturer on Agricultural Chemistry, West of Scotland Technical College.

MESSRS. SMITH, ELDER, AND CO. have issued a third edition of the "Junior Course of Practical Zoology," by Prof. A. Milnes Marshall, assisted by Dr. C. Herbert Hurst. Advantage has been freely taken of corrections and suggestions received from many sources. The whole book has been carefully revised, and some new figures have been added.

THE Royal University of Ireland has issued a supplement to its Calendar for the year 1892. It includes the examination papers used in 1891.

A NEW series of compounds, in which the hydroxylic hydrogen of phenols is replaced by the element titanium, are described by M. Lévy in the April number of the *Annales de Chimie et de Physique*. The first member of the series, that derived from the simplest phenol, carbolic acid,  $C_6H_5OH$ , possesses the composition  $TiO_4(C_6H_5)_2$ , or  $Ti(C_6H_5O)_2$ . The discovery of these somewhat remarkable compounds was the result of an investigation concerning a colour reaction of titanic acid. M. Lévy had observed that when a small quantity of titanic acid was brought into contact with sulphuric acid containing a little phenol, a deep red coloration was produced. The red colouring matter was soluble in the oil of vitriol, but was decomposed when the solution was diluted with water or neutralized by alkalis. The red substance has, however, been isolated by employing another mode of preparation, and proves to be the titanium phenylate,  $Ti(C_6H_5O)_4$ , above mentioned. It may readily be prepared by the action of titanium tetrachloride,  $TiCl_4$ , upon a solution of phenol in benzene. The titanium trichloride, in quantity one molecular equivalent, is poured directly into the solution of four molecular equivalents of phenol, when a very energetic action occurs with liberation of a large quantity of hydrochloric acid gas. The last traces of hydrochloric acid are removed by means of a current of hydrogen, the reaction flask being warmed to about  $70^\circ$  by means of a water-bath and fitted with a reflux condenser. Upon the completion of the reaction the benzene is evaporated off, when the new compound is left behind in the form of large crystals. The crude substance thus prepared is then recrystallized from a mixture of benzene and petroleum, when it is obtained in the form of rhombohedral crystals of the colour of bichromate of potash, and which, like the latter compound, yield a powder much yellower in colour upon pulverization. The crystals are readily soluble in benzene, toluene, alcohol, or ether. They also dissolve in concentrated sulphuric acid, producing the same red oil which is formed in the colour reaction above described. The action of water upon the crystals of titanium phenylate appears to be of the nature of saponification. It occurs in at least two stages, a compound  $TiO_4H_2(C_6H_5)_2$  being first produced; this intermediate compound passes eventually into titanic acid, carbolic acid being at the same time formed in the solution. Fuming nitric acid, when in large excess, converts titanium phenylate into titanic and picric acids; but if only a small quantity of nitric acid is employed, titanium picrate is precipitated in the form of a black insoluble substance. Nascent hydrogen, liberated by means of dilute hydrochloric acid and zinc or tin, reduces the titanium in titanium phenylate to titanium trichloride, with production of the usual violet coloration due to that compound. Gaseous chlorine rapidly converts the crystals of titanium phenylate into titanium tetrachloride and the di-chlorine derivative of phenol. In addition to titanium phenylate, the analogous compounds with the cresol phenols, thymol, naphthol, resorcinol, and salicylic

acid have been prepared. They are all red or brownish-red solid substances possessing properties similar to those of titanium phenylate.

THE additions to the Zoological Society's Gardens during the past week include a Grivet Monkey (*Cercopithecus griseo-viridis*  $\delta$ ) from North-east Africa, presented by Miss G. A. Vicars; a Leopard (*Felis pardus*  $\delta$ ) from Ceylon, presented by Mr. Marcus W. Millett; a Lesser Sulphur-crested Cockatoo (*Cacatua sulphurea*) from Moluccas, presented by Mrs. Kate Taylor; a Greater Sulphur-crested Cockatoo (*Cacatua galerita*) from Australia, presented by Mr. Earle Whitcombe; a Common Zebra (*Equus zebra*  $\varphi$ ) from South Africa, a Wonga-wonga Pigeon (*Leucosarcia picata*  $\varphi$ ) from New South Wales, a Cereopsis Goose (*Cereopsis nova-hollandiae*) from Australia, deposited; a Yak (*Poephagus grunniens*  $\delta$ ), born in the Gardens.

#### OUR ASTRONOMICAL COLUMN.

ASTRONOMY AT THE PARIS ACADEMY, APRIL 11.—MM. Périgaud and Boquet have independently made some observations of the latitude of Paris Observatory, one of the objects of the investigation being to determine whether the value underwent a periodic variation. The two series of observations only differ from one another by about one-hundredth of a second of arc; the value derived from them is  $48^\circ 50' 11''.01$ . No definite evidence of variability was obtained. Admiral Mouchez, in commenting upon these observations and a discussion of the latitude of the Observatory, made by M. Guiliot in 1879, said that doubtless the variation found at other Observatories was wholly or in large part due to the influence of temperature on astronomical refraction. A photograph taken by Dr. Gill was presented by Admiral Mouchez to the Academy. It embraced an area of  $2^\circ \times 2'$ , and on this sky-space from 30,000 to 40,000 stars had left their impressions, besides two nebulae. The exposure given was 3h. 12m. instead of the 1h. which is given to plates for the "Carte du Ciel." If this exposure were possible for the whole photographic map of the heavens, about 300,000,000 stars would record their existence instead of 30,000,000.

Swift's and Denning's comets have been observed at Bordeaux on several occasions. The former is described as very brilliant, with a nucleus of about the seventh or eighth magnitude, a head about  $8'$  in diameter, and the trace of a tail. M. Landerer has compared the calculated time of eclipses of Jupiter's satellites given in the *Connaissance des Temps* with the actual times observed. The agreement between the two is very remarkable.

SOLAR HEAT.—Volume ii. of the Transactions of the Astronomical and Physical Society of Toronto (1891) has recently been issued. It contains several interesting papers, one of which, by Dr. Joseph Morrison, deals with solar heat. Two theories have been advanced to account for the source and maintenance of the heat of the sun. One ascribes the heat to the energy of meteoric matter falling on the sun, the other asserts that the supply of heat is kept up by the slow contraction of the sun's bulk. Taking the "solar constant" as twenty-five calories per square metre per minute, Dr. Morrison calculates that the linear contraction of the radius of the sun which is requisite to keep up the present rate of radiation, is 0.00004972 feet in 1 second, or 156.9 feet in a year, or 29,716 miles in a thousand years. "Now 450 miles of the sun's diameter subtends at the earth an angle of  $1''$ , and therefore it would require 7575 years for the sun's angular diameter to be reduced by  $1''$  of arc, which is the smallest angle that can be accurately measured on the solar disk." With regard to the meteoric theory of solar energy, a calculation shows that a quantity of matter which weighs one pound falling freely from infinity to the sun would develop by its kinetic energy 82,340,000 units of heat. From this it can be found that the heat radiated could be developed by the annual impact on the sun of a quantity of meteoric matter a trifle greater than  $1/1000$ th of the earth's mass, and having a velocity of 382.6 miles per second.

PERIODIC VARIATIONS IN LATITUDE.—Mr. Chandler, in some recent numbers (248 and 249) of the *Astronomical Journal*, announced the discovery that the earth's axis of rotation revolves round her axis of maximum moment of inertia in a period of

about 427 days. In the *Monthly Notices* for March, Prof. Newcomb contributes a paper on the "Dynamics of the Earth's Rotation," in which this result is mentioned with reference to the periodic variations in latitude. By dynamic principles the ratio of such a rotation to that of the earth's revolution "should be equal to the ratio of her polar moment of inertia to the difference between the equatorial and polar moments." This gives a time of rotation of 306 days. Mr. Chandler's result, as Prof. Newcomb says, "at first sight seems in complete contradiction to these principles," and he is led to inquire into the theory which assigns the time of rotation. The present paper is the result of such an investigation, and he finds that two defects have made themselves apparent—"namely, the failure to take account of the elasticity of the earth itself, and of the mobility of the ocean." If the earth be considered first of all to be rotating as a homogeneous spheroid covered by an ocean of the same density as itself, the axes of rotation and figure would of course be perfectly coincident. By supposing a slight displacement of the axis of rotation of  $0^{\circ}20$  in the case of our earth, he estimates approximately one-fourteenth of this as the movement of the axis of figure in consequence of the shifting of the ocean. As two-sevenths are required by Mr. Chandler's results, "the ocean displacement only accounts for one-fourth of the difference." Since the remainder must be attributed to the elasticity of the earth, he inquires into the rigidity that our planet must have, so that the displacement of the axis of figure may be two-sevenths that of the axis of rotation: the result of the inquiry is to find that a rigidity greater than that of steel must be assigned to it. The effect of viscosity, he mentions, makes the normal pole move slowly and continuously towards the revolving one, so that in time they would meet if they were not acted upon occasionally by some opposing forces. The pole of rotation, according to Chandler's period, makes six revolutions in seven years, and Prof. Newcomb investigates the effect of an "annually repeated cause" that might produce such a change in the position of the earth's axis. This effect, as he points out, would be cumulative for one-half the period of seven years, and as the displacement is small, a comparatively minute disturbing force can be looked for. Basing his calculations on Chandler's period, he finds that such an effect can be obtained, for, "if the winters in Siberia and in North America occurred at opposite seasons, we should have no difficulty in accepting the sufficiency of annual falls of snow to account for this anomaly."

#### RECENT ADVANCES IN PHYSICAL CHEMISTRY.<sup>1</sup>

IN its course of development from a descriptive into a rational science, chemistry has, in a tolerably regular series of changes, passed in turn through periods of more special and of more general interest. While the gathering together of empirical facts proceeds in quiet, steady work, little troubled by minor and rapidly decided differences of opinion, it is regularly noticed, upon the other hand, that more generalizing ideas, brought forward for the purpose of a rational comprehension and unifying of this material, obtain only in the rarest cases a kindly, immediate reception. On the contrary, the reaction which such things at first call forth is almost always a more or less violent opposition, its precipitate it is to be sought out upon the filter of the scientific literature of the time, there coming afterwards to our view, in the text-books, only the clear filtrate of the pure results. This has scarcely ever appeared more strikingly than in the fall of the phlogiston theory: the periodicals and books of the last century resound again with the strife of the opponents, and often enough were the moral qualities of the newer party attacked when the opposed arguments became threadbare; whereupon from the attacked party a corresponding reply was never lacking. The intellectual combat died away but slowly, until the new territory was occupied in common in peace and harmony. We have lived through a similar experience in the change from the electro-chemical theory to the substitution-theory, in the transfer from the idea of equivalents to that of molecular quantities, in the transformation of the radical theory into the theory of types and structure. Even the younger men among us remember the strong opposition with which was greeted at its first appearance that idea of the

arrangement in space of the atoms in molecules, which now occupies so many investigators.

So it is a bloody field, whose present condition I have undertaken to represent to you to-day. Do not fear that I shall bring the uproar of conflict into this hour of peaceful looking backward and forward. I have rather called up these recollections in order to awaken in you the consciousness that this strife, which has indeed not been wanting in the more recent years of the development of general chemistry, is no abnormal phenomenon, possibly called forth by an unusual inferiority of the newly appearing general ideas or of their defenders, but that it is only a question of the normal birth-pains which unavoidably accompany the appearance of important generalizations.

But before taking up connectedly these newer and newest things, it will be in place to cast a glance over the development of those fields whose progress has been of a steady nature.

First, as concerns the atomic weights. The investigations which have been carried on for some years by American and English investigators—Cooke and Richards, Morley, Lord Rayleigh, Noyes, Dittmar, and others—upon the relation between hydrogen and oxygen, have not yet been brought to a close. While most of the determinations have united to indicate that the ratio of the atomic weights of these elements is 1 to 15.87, thus differing about 0.8 per cent. from the previously assumed value 1 to 16.00, yet by means of a well-thought-out method, Kaiser has found first 15.945, while he has now just announced that the most probable value is the old 1 to 16.00. It is remarkable that the efforts of so many investigators to determine this fundamental constant accurately to within one part per thousand have not yet met with a generally-accepted success.

In this connection are to be mentioned the discussions, which have been held upon the question as to the practical unit for the atomic weights, whether  $O=16.00$  or  $15.96$  should be employed. This is not the place to test the grounds adduced on both sides. Perhaps it may be possible, with the present stricter organization of our Society, to form a commission which shall subject the question to a general examination, and which, by the standing of its members, shall be endowed with sufficient authority to insure to its decision some prospect of general acceptance.

The question as to the connection and significance of the numerical values of the atomic weights has made no progress of importance since the fundamental researches of Lothar Meyer and Mendeleeff. Indeed, speculations do not cease in the direction given by the assumption of a compound nature of the elements, yet I know of none for which I could dare prophesy growth and development. Steady work in the revision of the numerical values of the atomic weights has been patiently prosecuted. I need mention especially only the close of the researches of the untiring Seubert upon the metals of the platinum group; and we should recognize with great thankfulness the devotion with which this work, so thankless in itself, has been carried through.

No new elements of importance have come recently to light. Although in the garden of the "rare earths" many a blossom has appeared, there fall as yet any real fruits.

In the theory of gases the investigations continue according to the general equation of condition (*Zustandsgleichung*), in that the recognition is steadily breaking its way, that the nearest entrance to the theory of liquids leads necessarily over the critical point. The kinetic hypothesis, which was greeted in its time with so much sympathy, and has enjoyed such careful attention, is showing itself here essentially unfruitful, since the two main principles of the theory of van der Waals, to which the immediate future undoubtedly belongs, are independent of the kinetic hypothesis. In fact, neither the assumption that only the space which is *not* filled with the substance of matter follows Boyle's law, nor the assumption that this matter possesses still some energy of reciprocal action, necessitates any definite representations whatever in the sense of the kinetic hypothesis.

Among the experimental researches upon these relations are especially to be mentioned those of Ramsay and Young. The relation determined by them, that within a very wide range the equation  $p(v-b) = \int T$  is true, or that the co-volume,  $b$ , is independent of the pressure, is one of the few general facts which are leading us to a more accurate knowledge of the general equation of condition.

In solving the task of finding a theory of the liquid condition, we shall have to seek other properties, which show themselves to be here subject to the more simple laws. As yet but few

<sup>1</sup> Address delivered before the united Sections of Physics and Chemistry at the yearly meeting of German Men of Science and Physicians at Halle, September 24, 1891, by Prof. W. Ostwald, Ph.D., of Leipzig.



such have become known, and still fewer have been considered in this manner. In addition to the above-mentioned result of Ramsay and Young, there claims attention one discovered by the Hungarian physicist Eötvös, according to which the *molecular surface energy*, as expressed by the product of the capillary constant and the 3rd power of the molecular volume, is shown to be a linear function of the temperature. Since the surface energy stands in closest connection with the energy of interaction, by virtue of which the substance of liquids, in contrast to that of gases, assumes its own proper volume, and to which is accordingly due the characteristic existence of the liquid condition, it becomes at once evident that here certainly a means of access to the theory of the latter is afforded. This means may be expected to lead more rapidly to the goal than the methods hitherto almost exclusively tried, based upon a relation between volume, temperature, and pressure.

The stoichiometry of the liquid organic compounds, founded by Hermann Kopp, has enjoyed likewise a steady development. While the question of the boiling-point seems to be essentially postponed until the general theory of liquids becomes known, yet that of the molecular volumes has reached a stage which already assures the prospect of a successful period of development. The additive scheme, proposed by Kopp as a first approximation, according to which the molecular volume is the sum of the atomic volumes—a scheme whose insufficiency Kopp himself had shown in the case of oxygen—determines only the roughest outlines of the phenomenon in question. Other factors make themselves everywhere felt; as was shown by Kopp for oxygen—that the portion of the molecular volume due to it can assume different values according to the function of this element in the compound, *i.e.* according to the constitution of the molecule—so the same holds for the other elements. An essential difference between univalent and bivalent elements is, in this respect, not present: ethylene and ethylenic chlorides have different molecular volumes, although they both contain saturated carbon atoms, and, in addition, only univalent elements.

We must, accordingly, more than ever before, recognize the molecular volume as a constitutive property. This recognition reaches at once the firm barrier to which the additive scheme, greatly against the will of its originator, had hardened. In vain had been for so long striven to force the facts into this form; ever and again their living body would not fit upon the wooden cross. Now we see that this undertaking was necessarily in vain: we begin to comprehend that methyl alcohol must be more different from ethyl alcohol than ethyl alcohol from propyl alcohol; and that these two, again, must stand in a different relation than do propyl alcohol and butyl alcohol, although each time the "same" difference of  $\text{CH}_2$  is at hand—that there are, in short, no two pairs of compounds whose differences are entirely the same.

Now, it is quite dependent upon the nature of the property considered, in what relation the additive foundation stands with the modifying effect of constitution. With the molecular volume the first is comparatively superior; with the boiling-points, however, the latter make themselves to the most superficial observation so energetically felt that, since the attempts of Schröder, Löwig, and others, which over fifty years ago failed to carry through the additive scheme for the boiling-points of organic compounds, this line of effort has been definitely given up. The other properties which have been studied fall between these two limits.

This holds especially for the molecular refraction. Just as Buff had earlier shown that "double bond" carbon possesses a greater molecular volume than does saturated carbon, it has been demonstrated by Brühl that a similar relation holds for the molecular refraction. This influence of constitution is, however, not the only one; a similar inference has been shown for oxygen and likewise for chlorine, and it has been repeatedly shown that, even if approximately additive laws be followed among the higher members of homologous series, yet these do not apply for the first members. This is necessarily so, as has already been shown in discussing molecular volumes.

The magnetic rotation is a property of much more strongly marked constitutive character than are molecular volume and molecular refraction. We possess here most excellent investigations by Perkin, which have often been found of service in determining questions of constitution.

In relation to the connection between the different properties of substances a fruitful line of thought has been carried out by Philippe-Guyé. As is known, Maxwell had derived a definite

relation between the coefficient of refraction and the dielectric constant, from his wide-reaching speculative investigations, which latter had yielded a complete analogy of the mathematical expressions for electro-dynamical and optical action at a distance, together with an approximate equality of the fundamental constants, and which have been finally made fruitful by the brilliant experimental investigations of Hertz. This dielectric constant is in turn, according to an expression due to Clausius, a simple function of that fraction of the total volume of a dielectric which is occupied by the actual material substance (considered as conducting). But this so called true molecular volume is, finally, nothing but the co-volume in the equation of Van der Waals. There is accordingly to be expected a close connection between the critical constants and the molecular refraction, and Guyé has shown that the expected connection actually exists.

Although spectrum analysis, with its manifold applications, has for years had almost no rational development, it has recently taken a quite promising start in the stoichiometric direction. The theoretical and experimental researches of Balmer, Deslandres, Julius, Rydberg, Kayser and Runge, and others, indicate already that the time is not far distant when there shall be simple and intelligible regularities in this field, which until now has been so overgrown with unfruitful hypotheses. Only upon one point I wish at this opportunity, as a chemist, to direct the attention of the physicists. It is held as an undoubted dogma that at the highest temperatures, as, for example, in the electric light arc, all compounds must be dissociated into their elements. This view is certainly not justified. What we do know about the stability of compounds is, on the contrary, that all compounds which are formed with absorption of heat become *more stable* with rising temperature, and the reverse. Because the majority of the compounds known to us are formed from the elements with evolution of heat, and correspondingly become more unstable with rising temperature, the conclusion has been drawn that this is in general the case. But if we reflect that cyanogen and acetylene, two compounds formed with great absorption of energy, are readily formed in quantity, at the highest temperatures, in the blast-furnace and in the Davy arc light, we become conscious that the spectra occurring at high temperatures may, under proper conditions, belong to compounds which, formed with great absorption of energy, may have a fleeting existence confined to those temperatures only. From this point of view, many difficult facts of spectroscopy and spectrometry would have some prospect of a proper interpretation.

At the extreme boundary of the optical properties, towards the side of the constitutive character, stand finally colour and rotation of the plane of polarized light. Although the first property is decisive for one of the most important branches of technical chemistry, the dye-stuff industry, still but little is known as yet about the connection of colour with composition and constitution. The investigations of Krüss, Liebermann, and more recently Vogel, all indicate that the property is in great measure constitutive, becoming additive only within the narrowest limits of closely-related compounds. This renders correspondingly difficult a recognition of the connections at hand. Some time later, on the contrary, directly on account of this marked constitutive character, the colour will be an important aid in the determination of constitution; at the same time, when we shall have learned to recognize this connection with some certainty, the discovery of new dyes with definite properties will be no longer a matter of a lucky hand and of an unconscious feeling for this connection, but will rest upon just as broad a basis as, for example, the technic of the metallurgical processes.

The constitutive character of the rotation of the plane of polarization has been always known and recognized. Since van't Hoff and Le Bel, twelve years ago, pointed out the connection between this property and the presence of an "asymmetrical" carbon atom, *i.e.* one joined with four different elements or groups, this idea has, at first slowly, then more and more rapidly, had an important development. For the "optical symmetry" shown by Pasteur in the tartaric acids, the examples have become more and more numerous; the researches of Wallach on the ethereal oils have especially furnished valuable material. The presence of optical activity is now held as an entirely undoubted proof for the presence of asymmetrical carbon, and Le Bel has just announced that he has succeeded in the preparation of optically active nitrogen compounds containing an asymmetrical nitrogen atom.

The investigator whom we have already mentioned, Philippe-

Guye, has made a remarkable attempt to find laws for the numerical values of the molecular rotation, by giving to the asymmetry of the carbon atom a numerical measure dependent upon the masses joined thereto, and, in cases of analogous compounds, comparing this with the values for the molecular compounds. While this attempt has been well supported by a number of older measurements, especially those of Pictet on the esters of the tartaric acids, yet his own determinations on the active amyl derivatives have not indeed furnished much very favourable evidence. He has not overcome the difficulties of obtaining pure material, and certain facts were observed contradicting the assumption that the sense of the asymmetry is due to the masses added. It is not improbable that this difficulty will be overcome by placing the optical moment, if I may be allowed the expression, not proportional simply to the mass of the atom; there is rather to be suspected a connection with the atomic refraction.

We turn now to a field whose development belongs entirely to the last few years, to that of solutions. If we call to mind the old saying, *Corpora non agunt nisi fluida, vel soluta*, we perceive at once the very great importance of the field; all rational knowledge of chemical processes must be preceded by a corresponding knowledge of the condition of dissolved substances.

It does not need to remind you that van 't Hoff's discovery of the identity of the laws of gases with those of dissolved substances, is to be characterized as the greatest step forward which has been made in this direction. If we reflect that the development of the molecular idea, which rules the chemistry of to-day, is most decidedly based upon the laws of gases in their simple form, we recognize at once that all the important relations which have been here found can be directly transferred to the domain of solutions. The latter has, however, at the same time, far more varied possibilities in the form of its phenomena. While in the case of gases only two of the variables, pressure, volume, and temperature, are independent, there is present for solutions the manifold infinity of the non-miscible and partially miscible solvents. To this is due the appearance of a great number of new formal and numerical relations for solutions, even under assumption of the simplest form of the governing laws, whereby a rich field of inexhaustible fruitfulness is made accessible to investigation. In fact, after this advance by van 't Hoff, the theoretical investigations of Planck, Riecke, Lorenz, van der Waals, and Boltzmann, as well as the progressive combination of theory and experiment by Nernst, have shown how varied and valuable are the results to be gained, results whose details I am here compelled to omit.

I wish, at this opportunity, to call attention to one particular point. I have already mentioned that the way to a rational theory of the liquid condition leads from the gases, through their variation from the simple gas laws, and through the critical point, whose constants express in especially simple form the individual properties of the kind of matter in question. Now it is to be expected from the theory of solutions, and it has been demonstrated in detail by O. Masson and W. Ramsay, that upon transition from a dilute to a concentrated solution we observe entirely the same phenomena that appear when the volume of a gas is diminished; there is here also a critical state with its corresponding constants. We thus have here a second way to a theory of the condition of pure liquids, which, by reason of the greater variety of the phenomena, is a far more difficult one than is that first named, but which, however, may in many cases be of assistance where the other fails.

While the already discussed parts of the newly-opened territory are mainly those problems with which physicists have concerned themselves, still its study has not been less fruitful for chemistry in particular, especially for organic chemistry. To the above-mentioned variety of the relations here present corresponds an equal variety of the methods of determination of that most important constant, the so-called molecular weight of dissolved substances. Since the tireless Raoult had shown years ago, in a purely empirical manner, the application of the properties of solutions to this purpose, it was reserved for the theory of van 't Hoff to discover the rational basis of these relations, and thus for the first time to give to wider circles of investigators a feeling of security in the making of such molecular weight determinations. Especial service has been rendered by E. Beckmann in the technical development of these methods; and the Beckmann freezing apparatus and boiling apparatus form at present just as necessary and much used a part of the equipment

of a laboratory as formerly the Hofmann apparatus for determining vapour densities.

It has naturally come to pass that, together with the suddenly increased range of molecular weight determinations, our views of the nature of this quantity and of the therewith connected question of valence have undergone a corresponding change. The conception had become gradually rather dogmatically rigid: it was understood to require for each substance only a single absolute molecular weight, the variations observed, for example, in the case of acetic acid, being characterized as anomalies. Molecular weight determinations in solutions have shown that such variations are so extended, and, at the same time, occur so regularly, that they may no longer be pushed aside as anomalies. It is therefore at present generally recognized that a substance may quite well have different molecular weights, standing in the ratio of simple multiples, the most important weight for the chemist being of course the smallest of them.

The consequences connected with van 't Hoff's discovery being so important and wide-reaching, they have had in general a friendly reception, although a few scientific men—not of the highest rank—fearing the little plants cultivated by them to be endangered by the flood of light falling upon them, have attempted a slight resistance. On the contrary, all the uneasiness which is unavoidably connected with important revolutions has been directed against a second idea, which, appearing somewhat later than that of van 't Hoff, removed a fundamental difficulty in the theory of solutions, which had until that time made its acceptance impossible for me. This idea has at the same time shown itself as an aid to investigation to be of unexampled sweep and value. This is the theory of electrolytic dissociation, of Arrhenius.

It is certainly to be presumed that the fundamental idea of this theory is generally known. In the aqueous solutions of the electrolytes, the salts, acids, and bases, a greater or less proportion of the dissolved molecules are regarded as split up into electrically charged constituents or ions, which exist in the solution independently of one another in the same manner as the partial molecules of a dissociated gas. If the van 't Hoff theory be admitted, it must be admitted that in a solution of sodium chloride, for example, almost double as many individual particles or molecules are present as in a corresponding solution of sugar or urea of the same formula weight. The experimental connection of these variations with the fact and numerical amount of the electrical conductivity, first discovered by Arrhenius, and which cannot be denied, furnishes the basis for the second part of the theory of Arrhenius, the assumption of electric charges upon the separated molecular constituents or ions. If now these fundamental ideas are accredited, the remainder follows with directly evident necessity.

The significance of these views becomes apparent upon considering the quite astonishing range of phenomena in the most widely separated parts of physics and chemistry which have received explanation from the theory of Arrhenius in connection with that of van 't Hoff. It is simply impossible in the limits of this address to even enumerate these single applications; I shall, as I think, do better by treating the question from a more general standpoint, and, without speaking in particular of each advance made, sketch in rough outline that field in which both theories have brought or will bring decisive explanation.

Let it be first called to mind that the laws of dissociation were already earlier derived thermodynamically for gases. If, then, in the field covered by Arrhenius, the question be one of dissociation, and the laws of gases do, according to van 't Hoff, hold for dissolved substances, it follows that the entire theory of the chemical affinity of electrolytes must be yielded by the application of those laws of dissociation. This means nothing less than that the problem of chemical affinity is in reality solved.

The conception of chemical affinity is to be understood to reach so far as to include all phenomena caused by the so-called inner energy of bodies. It includes, then, not only the processes especially termed chemical, but also those of vaporization and solution without exception as well. If it be wished in the latter case to preserve the ever emphasized but still unclear distinction between "chemical" and "physical" processes, to the former may be reckoned those processes in which electrolytic dissociation comes into question, and to the latter those in which this is not the case. Thus, the dissolving of oxygen in water is in this sense a "physical" that of hydrochloric acid in water a "chemical" process. But this distinction is secondary: it is expressed only in the greater complication of the corresponding

formulæ; the fundamental equations remain everywhere the same. In other words, the question is one of the theory of all conditions whereby heterogeneous substances or heterogeneous phases of the same substance have assumed, after reciprocal influence, a condition of equilibrium independent of the time.

The general theory of these conditions has been developed by J. Willard Gibbs sixteen years ago; a German edition of this magnificent and incredibly many-sided investigation is at present in the press. Through van 't Hoff and Arrhenius we are placed in a position to insert in the equations of this man of science, which contain necessarily a great number of yet unknown functions, the expressions for these functions, together with the numerical constants, and to thus solve the problem numerically from case to case.

It must, however, be borne in mind that the functions in question, expressing as the sum of its single forms the total energy of the system considered, are yet known only for the cases of gases and dilute solutions, *i.e.* for the cases where the inner energy has become independent of the volume. As far as the knowledge of the equation of condition reaches, extends the possibility of mastering the heterogeneous conditions and chemical equilibria. And we see at this place how the different parts of general chemistry reach to one another the hand; the solution of the problems which were mentioned in the first part of this address is also, for that just discussed, the unavoidable condition of progress.

But with the range just measured off, great as it is, the limits of the province of the van 't Hoff-Arrhenius theory are not yet reached. The dissociation discovered by Arrhenius is an *electrolytic* one. Accordingly, the immense number of phenomena, in which the electrically charged ions participate, belong likewise with those which here receive a new light. The question as to the source and maintenance of the electrical energy in the galvanic elements, as to the conduction of current in electrolytes, as to the meaning of galvanic polarization, are only single points in this field. Electro-chemistry in the widest sense, and, indeed, as much so that part which is concerned with essentially electrical questions as that which studies chemical questions, has already received most valuable furtherance from our theory, and has yet more in prospect.

It is natural, as against this exposition, to propose the question how the theory of van 't Hoff and Arrhenius has responded to the requirements which have been made upon it in a so extraordinarily wide-reaching and varied manner. Since I belong to the few who make use of this aid in their investigations, I must freely confess that my judgment in this matter may be looked upon as subjective; but since, on the other hand, I hold to both theories unfortunately, not the position of a father, but only that of an uncle of rather distant relationship, you may trust me that at the time of first meeting them I was rather inclined to repel than to greet them. I can then only personally declare that no scientific idea produced in my time has assisted me in such measure as has this one, and that I have further gained the impression that the great scientific fields named have received likewise unusual furtherance from this idea. In particular the extraordinarily manifold and severe test which lies in the numberless numerical consequences of the theory in all possible fields, has yielded such a number of confirmations that the relatively rare cases where the unprejudiced decision was "insufficient" entirely vanish. Naturally must not be considered the judgment of those who, with insufficient qualifications, set themselves up as judges, who do not attempt to test the theory, but only to refute it. The misunderstanding and false conceptions from which such "refutations" proceeded have been in fact of such kind that thereout no real progress, which is the end of every scientific undertaking, has resulted.

I hasten to close. The concise review of the working ground of general chemistry, which I have just attempted to give, shows to what great extent chemistry has made use of physical means to solve her problems. It is, therefore, not especially necessary to urge my chemical associates that they should follow up the study of physics and acquire the necessary mathematical knowledge. It is cared for at many Universities by the more far-seeing teachers of chemistry, that this indispensable knowledge is made as accessible as possible to our youths, and my personal experience has shown me that such opportunities are gladly and profitably used.

But the reverse does not present so favourable an aspect. The science of physics requires for its extension and development exhaustive chemical knowledge in many directions. All

phenomena in which the special character of matter comes into question require for their study an extended knowledge of just this character, *i.e.* chemical knowledge. And I cannot avoid complaining that in this direction too little is done. In the more recent physical literature, I have met not seldom chemical views, which were, in short, fearful, and which gave to the interpretation of the observed phenomena an entirely false direction. The physicist is only too inclined to consider chemistry as an inferior science, of which he knows a great sufficiency if, in the early part of his student-life, he has once heard its lectures. Nothing can be more wrong than such a view. By reason of its richer and more special store of facts, chemistry really remains behind physics in its development into a rational science, and it will ever so remain, in the same way as physics remains behind astronomy or mathematics. But directly for this reason the beginning of the student years is the only time in which to become acquainted with the varied details of chemical phenomena, and to take up the enormous range of experience here offered. For, according to experience, the physicist never learns them later. The history of our science points out a number of men, who, from chemists, have become physicists of high rank; I need name only Regnault, Faraday, Davy, Magnus, Hittorf. But I cannot name a single man of science who, after having been trained as a physicist, has made one purely chemical discovery of importance, for it never occurs that a physicist *later* learns chemistry. The great range of empirical experience can only be incorporated into the memory at a time when the latter is fresh, and it is usually already too late but a few semesters after the student life has been begun.

I can, therefore, not urge my physical colleagues enough: send your students at first for a few semesters into the chemical laboratory. We chemists must indeed do our part, in suitably rearranging the laboratory instruction; the practice in qualitative analysis should, in particular, be greatly cut down, and in its place preparative work in its widest sense, together with the typical forms of quantitative analysis, should be taken up. But since the same requirements are to be made upon the education of the future teacher of the natural sciences and mathematics in the *Gymnasien* and *Realschulen*, it will not be difficult to soon find the methods best adapted for the chemical education of all non-chemists, without injuring the immediate purpose of the chemical laboratories—the training of chemical specialists.

### THE GENERAL CIRCULATION OF THE ATMOSPHERE.<sup>1</sup>

IF the question of the general circulation of the atmosphere were referred to a meeting of educated people, one might be sure that ninety out of a hundred who could give any answer at all would explain it by the time-honoured equatorial and polar current; if anyone initiated in the subject sat near, one would observe a pitying smile upon his lips, and, if asked for his opinion, he would relegate that current, of sacred memory, to the region of the fables, or at most only allow it to hold sway, with certain limitations, in the tropical and sub-tropical zones, the region of the trade-winds; the temperate and cold zones however would be reserved for the dominion of the variable winds, and of newly arisen cyclones and anticyclones, of which we cannot tell whence they come and whither they go, *i.e.* for the origin and disappearance of which we cannot lay down any laws. And if there were several of these initiated persons present, a discussion would at once occur, from which no one could obtain a clear idea, and which would leave everyone with the impression that nothing certain was known about the subject. I suppose that you have been present at such a discussion, and have appealed to me to explain to you the present state of our knowledge of this subject.

I undertake this task the more willingly, since the question of the general circulation of the atmosphere has but recently entered upon a new stage, which marks a great step towards the complete solution of the question, and because it is very desirable to obtain as wide a diffusion as possible for this theory which corresponds to the present state of the science.

In this question especially, as in many others, the history of the development is exceedingly instructive, and of the greatest value in aiding a comprehension of the subject. I propose, therefore, that you should follow me through the different stages

<sup>1</sup> Translation of a lecture delivered by Dr. J. M. Pernter through the Scientific Club in Vienna.

which the explanation of the general circulation of the atmosphere has undergone; little or nothing more will then be wanting in order to understand the answer to the question at issue.

Dove was the first person who advanced a theory of the general circulation of the atmosphere after meteorology took a place among the exact sciences. He considered the question from a high and correct stand-point, because he considered the atmospheric envelope of the earth as a whole, which received its motion from the sun, the universal motor. According to his theory, the explanation of the general circulation of the atmosphere took the following form:—

The heat of the sun is not uniformly distributed over the earth's surface, but decreases from the equator to the poles. The greatest heat occurs at the equator, and the least at the poles. The air which is greatly heated at the equator must consequently rise, an ascending current must be developed there (the celebrated *courant ascendant*). The zone of calms is the region of the ascending air current. The air carried upwards must flow away above towards the poles, while, owing to the rotation of the earth, it endeavours to deviate to the right; the equatorial current is originated as an upper south-west wind, in the higher strata of the atmosphere. The flow of the upper air towards the poles is compensated below by the flow of the air towards the equator, and this polar current seems to be turned away towards the west owing to the rotation of the earth; it appears on the earth's surface as a north-west wind, and blows as far as the zone of calms, where it ceases, and the air brought with it is carried upwards in the ascending air current, where the circulation then begins afresh.

You see that this theory leads to a circulation of the air between pole and equator. The air rises at the equator and flows towards the poles, in order to descend there and to flow again towards the equator. But Dove states expressly that the equatorial current partially descends, even in the temperate latitudes, down to the bed of the polar current. If this happens, and according to Dove this continually occurs, then both winds, the equatorial and polar currents, begin the conflict for the mastery. The variable winds of the temperate zone arise out of this conflict, and Dove deduced therefrom his law of wind gyration. The description which he gave of this conflict of the opposing equatorial and polar currents is a thoroughly masterly picture, and it is in a great measure owing to this elaborate completion of his exposition that his theory of the general circulation of the atmosphere and his law of wind gyration were accepted by scientific men. The reader is carried away by it as if he were present at the conflict of the winds in *Æolus's* mythological cave, and he is inclined to believe that science verifies the ancient mythology so far as regards the lower latitudes. Dove's theory found an actual support in the trade-winds, and in the law of wind gyration which generally obtains in Central Europe. In fact, in our regions, the wind rotates very frequently from east through south to west and north. Dove's explanation of this, the conflict of the equatorial and polar currents must have appeared to be correct as long as no more serious investigations existed.

Since 1863, weather telegraphy and synoptic weather charts have led to the discovery of the baric wind law (Buys Ballot's law), and the position was at once changed. We learned that the winds depend upon the differences of pressure which prevail over the region under consideration, and that they circulate round the place of lowest pressure; *i.e.*, with us, they flow to the place of lowest pressure, in spirals opposite to the movement of watch hands.

It was now said that the cause of the winds in our latitudes was not the great heating of the air at the equator, but the differences of pressure which were formed in the temperate zone. The law of wind gyration also became untenable. It was found that the swirls which arose about the place of lowest pressure do not stand still, but move, and it was seen that Dove's law of wind gyration for places which lie northwards of the tracks of these swirls does not hold good, in fact that the rotation is exactly the reverse.

The reason why Dove's law of wind gyration mostly holds good in Germany and Central Europe, was found to be that the tracks of the swirls almost always lie to the northwards of Central Europe, and therefore the law must hold good there. But as often as a swirl moves more southwards all places in Central Europe which lie to the north of it have a wind rotation which is opposed to Dove's law.

The equatorial and polar currents, so far as regards the higher latitudes, were thus driven off the field, and the conflict between them, so beautifully described, was again relegated to the mythical cave of *Æolus*. As it was feared that the wheat might be thrown away with the chaff, it was wished that the equatorial and polar current should be banished from the higher latitudes altogether, but left, in a more limited sense, only in the regions of the trade-winds—between the zone of calms and about 30° north and south latitude; for here it was clear that Dove's theory held good. People unceremoniously denied the right of the polar current to blow beyond the 35th parallel, for in this latitude, as observations show, a band of high pressure encircles the whole earth, while from there the pressure decreases both towards the equator and the poles. But according to the baric wind law the wind can only flow from a place of higher to one of lower pressure; the air can therefore only flow from the 35th parallel towards the pole, and not the reverse. The polar current was thereby banished without mercy from the higher latitudes. The equatorial current fared somewhat better in the upper regions. Many persons allowed it to remain in a small degree, especially those who recognized the accuracy of the calculation according to which in the higher atmosphere, about 4000 m. and over, the pressure decreases from the equator to the pole. But very few persons knew what to make of this equatorial current in the upper regions, and so at all events it was little regarded. Generally speaking, the *régime* of cyclones and anticyclones was established for the higher latitudes, and people were completely absorbed in investigating the details of their qualities and tracks, without having hitherto succeeded in obtaining a satisfactory explanation of their origin and development. With regard to the propagation of cyclones, it was observed that with few exceptions they advanced from the westward to the eastward. Gradually, opinions became general that it was the south-west and west wind of the upper regions which brought the cyclones with it; some persons explained this west wind in the upper regions as the equatorial current. But, on the whole, the general opinion of this period favoured the rejection of Dove's polar and equatorial current, and the explanation of all winds by the prevalent differences of pressure, without being able to account for the origin of the latter.

Dove was of an excitable temperament, and he strongly combated these new views, and laid too much weight on the defence of the defective portion of his theory. His contest was fruitless, and only caused him to be accused with some justice of hindering the progress of meteorology by his great authority. Dove at length remained silent, and the funeral anthem of the polar and equatorial current was then chanted.

Mühyr, a well-known meteorologist of the Dove school, survived him, and constantly raised his voice in favour of Dove's equatorial and polar current; he attentively followed the progress of meteorology until his death, a few years ago, and the way in which he frequently warned meteorologists against entirely excluding the equatorial and polar current from their considerations is quite stirring. He was continually trying to turn attention to it, but with him disappeared the last defender of Dove's theory.

But while meteorologists were almost exclusively concerned with the details of the phenomena offered by cyclones and anticyclones, and almost lost sight of the great problems which the consideration of the general circulation of the atmosphere affords, a revolution was being prepared, at first only individually, but gradually more generally, which disposed minds to the more favourable consideration of the general movements of the atmosphere.

More than thirty years ago, Ferrel, the great American meteorologist, was occupied with the question of the general circulation of the atmosphere. He developed its laws in a mathematical form, and arrived at the following theory:—

Three great zones of calms exist round the earth, one at the equator (or near it), usually called the calm-belt, the second and third 35° north and south of the equator, the so-called "horse-latitudes." Between the calm-belt and the horse-latitudes, the north-east or south-east trade-wind prevails at the surface of the earth, and in the higher regions above them the anti-trade (south-west or north-west). In the calm-belt, in which no other than an ascending movement of the air exists up to the greatest heights, an upheaval of the air occurs, and in latitude 35° a descent of the same. Northwards of 35° N., and southward of 35° S., south-west and west winds prevail both at the earth's surface and at great altitudes, while at a mean height a return

north-westerly current prevails. The heat of the sun, or difference of temperature between equator and pole, is the cause of this general circulation of the atmosphere, as Dove maintained; the deviation of the wind from the direction of the meridians arises from the rotation of the earth.

This whole theory of the circulation of the atmosphere, which Ferrel deduced by mathematical means, differs considerably from Dove's, but shows that Dove's fundamental idea was sound and worthy of respect.

Ferrel's investigation certainly remained long unknown in Europe, and when at length it became known, it was only received with a purely theoretical interest. It seemed to have no connection with the present almost exclusively interesting question of the origin, development, and propagation of cyclones, and so it was in fact set aside; although from that time people frequently referred to it, and began to pay more attention to the currents of the general circulation. But it was only in 1885 that Sprung in his treatise on meteorology could write: "And so the conviction is now often expressed that we have gone too far in accrediting the individual systems (cyclones and anticyclones) with the sole control over the motions of the air in higher latitudes"; and he then sets up a system of general circulation based on the same principles as those of Ferrel. Sprung's system corresponds tolerably well to Ferrel's, but he also finds in the trade-wind zone that the wind direction at a mean height deviates from the direction of the trade, namely south-east, over the north-east trade-wind. At great heights the westerly winds prevail from the equator to the pole, without passing to calms in the horse-latitudes. At the equator there exists an actual conical calm-zone pointing upwards, in which only ascending air-currents prevail up to the highest altitudes.

Although, owing to the esteem which Sprung's treatise everywhere found, this theory of the general circulation of the atmosphere continued to spread, it did not arouse great interest, because it did not take special account of the influence of these general currents on the formation and propagation of cyclones, which justly continued to attract the most general attention.

This influence of the general atmospheric circulation was first insisted upon by the celebrated physicist and mechanic, Werner Siemens, in 1886. He considered the origin of the general circulation of the atmosphere from the great and fruitful principle of the conservation of energy.

Siemens introduced his far-seeing considerations with the remark that, even if Dove's theory of the general circulation of the atmosphere, which consisted of the ascending air-current at the equator, and the development therefrom of the equatorial and polar current with its conflicts for mastery in the temperate zones, were defective, yet this explanation was at all events more satisfactory than the "present almost exclusive reference of the motions of the air in higher latitudes to minima and maxima of pressure." He rightly asks that the seat of the forces—which accumulate, in a manner that is not at present evident, powerful energy in the cyclones and anticyclones which produce storms and whirlwinds—and the point of their attack may be indicated. Siemens makes no new assertion when he attributes all the energy which occurs in cyclones and anticyclones to the heat of the sun, but he discusses in a new and very noteworthy manner the way in which the sun's heat produces the storms of our latitudes.

Siemens explains the general circulation of the atmosphere according to the following principles:—(1) Without the heat of the sun the earth's atmosphere would be in a state of relative repose, *i.e.* it would everywhere rotate with the angular velocity of the earth's rotation; we should have no winds. (2) In reality, the earth and its atmosphere are unequally heated, most at the equator and least at the poles; consequently, air currents must arise from the equator towards the poles. (3) The energy which is accumulated by the rotation of the atmosphere about the earth's axis must, however, remain constant and unchanged; the theory of the conservation of energy requires this. If, therefore, a continual change of the geographical position of masses of air takes place through equatorial and polar air currents, it must take place so that the velocity of rotation of the whole atmosphere remains unchanged. This is only the case when the velocity of rotation of the whole atmosphere over lower latitudes lags behind that of the earth, but in higher latitudes outstrips it.

It is evident from this that anywhere in middle latitudes, both north and south, there must be a belt round the earth where neither a retardation nor an acceleration occurs, *i.e.* where the

air is in relative repose with regard to the earth. Siemens calculates the position of this belt to be at latitude 35°.

According to Siemens, therefore, we have the following system of air circulation:—

Between latitude 35° N. and 35° S., the general movement of the atmosphere is directed towards the west, *i.e.* east winds constantly prevail there in all latitudes and at all heights. In the vicinity of the equator, where north-east and south-east trades meet, an interference occurs at the surface of the earth, which produces the calm-zone, but it does not reach to any considerable height. In the higher regions above the calm-zone, an east wind must likewise prevail.

In the higher latitudes, therefore, northward and westward of the 35th parallels, the general movement of the atmosphere must be directed towards the eastward, and west winds must generally prevail in these latitudes.

Now, what do direct observations say to this system of the general circulation of the atmosphere?

There is no doubt that between the 35th parallels an easterly air current prevails, *viz.* the trade-winds. It is also known that west winds prevail in the higher latitudes, and in the southern hemisphere they blow almost uninterruptedly. But Siemens's theory is not to be considered as proved by these general facts, although they are fully borne out in Ferrel's and Sprung's explanations; we must examine what is new in it more closely. Siemens's exposition requires an easterly air current at the equator, and even in the upper regions above the calm-zone. Does this exist? Until a short time ago, it was undoubtedly the general opinion of meteorologists that the calm-belt was a zone of actual calms up to the highest altitudes, and that only the slowly ascending current prevailed there; in the vicinity of the calm-zone, the trade-wind blowing below ought to rise, and with increasing height gradually assume a poleward direction, to appear soon as an upper south-west trade-wind. This theory, which had become rooted by custom and time, was upset by Siemens: between the 35th parallels there are only easterly currents—the strongest and most purely easterly over the calm-belt, and decreasing continually towards latitude 35°; in the upper regions, on approaching latitude 35°, these currents come continually more from the south, and at the earth's surface more from the north. This was then a serious revolution in the theory of the general circulation of the atmosphere, which even the great authority of Siemens could not carry through without further experimental proofs. He had not reduced his investigations to a mathematical form, and so his theory, notwithstanding the great respect due to his name, would with difficulty have obtained greater success, if facts had not recently become known, which appeared to confirm it.

It is known that after the Krakatō eruption, in the year 1883, the opinion was expressed that the frequent coloured phenomena of the sun in the tropics and the long evening glows were regarded as consequences of this eruption. The spread of these phenomena in the first ten days after the eruption was such that we were obliged to assume that the dust-haze thrown out had travelled round the earth in about twelve days from east to west; for the explanation of the diffusion of these phenomena, a violent easterly wind was required in the upper regions of the atmosphere in the vicinity of the equator. For a long time it was this easterly wind which threw doubt upon the whole hypothesis of the unusual appearances which were referred to the Krakatō eruption. But Siemens's theory of the general circulation of the atmosphere was thereby confirmed. It appeared, however, as if here two hypotheses happened to mutually support each other, and it was a long time before on the one hand the Krakatō hypothesis, and on the other Siemens's theory, were regarded as established.

This theory found however further support—on one hand in the observations of the motion of high clouds by Abercromby, and on the other in the mathematical establishment of Siemens's statement by Oberbeck.

In 1885, Abercromby, during a voyage from Aden to Australia, had observed that in the neighbourhood of the equator the cirrus moved from the east. He was much surprised at this, and wrote: "The discovery of an easterly current over the north-west monsoon is not only altogether new, but also quite anomalous." He thought this so important, that he undertook another voyage from Mauritius to Bombay, in order to clear up the matter. The result of his further observations is couched in the following terms: "I may point out another very important result of these observations—namely, that the highest air

current between the equator and the doldrums is always from some point near east.<sup>1</sup>

Here, then, was another actual confirmation of Siemens's theory. Two facts—the diffusion of the Krakatō dust, and Abercromby's observations—supported Siemens's theory of air circulation, yet doubts were not quite removed. Voices were loud against the Krakatō hypothesis and against Abercromby's observations, which allowed another explanation to appear possible. Meteorologists delayed mostly to accept Siemens's theory, because a theoretical, mathematical establishment of it was still lacking. But this was given, as before observed, by Oberbeck, a year or so ago. He arrived at formulæ by which Siemens's theory could be reproduced.

Now, in fact, nothing more was wanting. Siemens's system was confirmed on all sides, by facts and by mathematical treatment. The chief merit for this is certainly due to Oberbeck. Before I bring to your notice the system of the general circulation of the atmosphere, such as it is given by the present state of research, I must allude to one other point in Siemens's exposition—namely, the influence which the general circulation of the atmosphere should have on the origin of cyclones and anticyclones in our latitudes.

The origin of the maxima ought to be due to the fact that the air flowing from lower to higher latitudes is checked in consequence of the convergence of meridians, and so produces an increase of pressure. Thus we get the maxima, or anticyclones. If, then, in consequence of this increase of pressure below, air flows out laterally, and, in consequence of the interference, the confined current turns more to the eastward, it must carry the lower strata with it, and give rise to a rarefaction, causing a minimum or cyclone. But this is carried away as a whole by the general current, and thus the progression of cyclones is also explained.

Siemens holds very strongly to this explanation, principally because it contains a force which explains the energy which is accumulated in anticyclones and cyclones, and which refers finally to the heat of the sun, that maintains the general circulation. But I fear he has overshot the mark here. The meridians converge in the southern hemisphere the same as in the northern. Why, then, do almost constant west winds prevail there below, without interference of currents, while with us an almost uninterrupted system of driving cyclones and anticyclones exists? Does not this prove that in the formation of cyclones and anticyclones another factor is at work, and might not this perhaps depend on the peculiar distribution of land and water in the northern hemisphere? Upon this point Siemens will have to modify his views.

From my analysis we can easily sketch the outline of the general circulation of the atmosphere which corresponds to the present state of the science.

In consequence of the unequal heating of the sun and of the rotation of the earth, air currents occur at all parts of the globe. These currents are easterly between 35° N. and 35° S. latitude, and westerly outside this zone.

In the former zone the easterly currents on the earth's surface (in the northern hemisphere) are more north-easterly and northerly the nearer we approach latitude 35°, while in the higher strata they constantly become more southerly as we approach latitude 35°. This explains the circulation between the equator and latitude 35°. An upper south-west trade-wind entirely fails in this region.<sup>2</sup> At or near the equator a calm zone must be formed at the earth's surface, where the meridional components of the north-east and south-east trades ascend, but the height of the calm-zone cannot be considerable. Exactly over the calm-zone a pure east wind and the strongest of the whole zone will blow, and the higher the strata under consideration the stronger it will be.

In latitude 35° N. and S., calms exist at the earth's surface. The air, which has an ascending motion in the equatorial calm, has here a descending movement. But above, the current directed polewards continues to exist. Outside this great region, to the north and south, west winds will prevail; while above, the south-west (or the north-west) trade-wind blows, which in higher latitudes will become more and more westerly. At the earth's surface, air in south-westerly or north-westerly

motion flows from the zone of high pressure at latitude 35°, which becomes more westerly with increasing latitude. At a mean altitude, however, air flows again from the poles towards latitude 35° as a north-west wind.

This is the picture of the general circulation of the atmosphere according to the latest researches. There is undoubtedly much to be completed, and it presents many dark points which remain to be cleared up, but on the whole it possesses every guarantee of truth and reality, and will doubtless soon be generally accepted. The question of the effect upon cyclones and anticyclones of this general circulation of the atmosphere will certainly come to the front, but we shall have to wait for a considerable time for a satisfactory solution of the problem.

#### RELATION OF VOLTAIC ELECTROMOTIVE FORCE TO MOLECULAR VELOCITY.

IN a recent research published in vol. viii., p. 63, of the Proceedings of the Birmingham Philosophical Society, 1892, it is shown, by means of an extensive series of sixty-four tables of measurements of mean voltaic electromotive force, that the dilution of the liquid of a voltaic cell by means of water or alcohol, the liquefaction of either the positive or negative metal of the cell by means of mercury, the dilution of either of these amalgams by means of mercury, or the dilution of one solid metal by means of another in an alloy, is universally attended by an increase of mean electromotive force of the diluted and diluting substances, and consequently also of the actual electromotive force of the diluted one, provided that in all cases no chemical union or other chemical change occurs in the mixture. The manifest explanation of this extensive general result is that, by the act of solution or dilution, the molecules of the active substance are separated farther apart, and consequently acquire increased velocity of motion. In proportion, however, as chemical union occurs, the gain of electromotive force diminishes and is converted into a loss, and the loss is larger in proportion as the chemical union is stronger. The method enables chemical compounds in alloys, amalgams, and electrolytes to be distinguished from mere mechanical mixtures.

G. GORE.

#### SCIENTIFIC SERIALS.

IN the *Botanical Gazette* for February and March, Miss Alice Carter has an interesting paper on evolution in methods of pollination. She points out that the larger proportion of Monocotyledons are either anemophilous or hydrophilous, and this is undoubtedly an earlier method of pollination than the entomophilous. Of the twenty-three natural orders which comprise more than 1000 species, only five are characterized by inconspicuous flowers. Of these, four, viz. the Cyperaceæ, Gramineæ, Urticaceæ, and Piperaceæ, are probably ancestral types, the fifth, Euphorbiaceæ, degenerate. It is probable that the period of the appearance of Dicotyledons was also that of the development of our great groups of insects. The first step towards the attraction of insects was probably the colouring of the stamens, as in *Thalictrum* and *Plantago*; then the development and colouring of the corolla, and the production of saccharine secretions. The most highly developed orders appear to be those in which the number of parts in a floral whorl is small, as the Violaceæ, Composite, Labiate, and Scrophulariaceæ.—Mr. P. H. Rolfs has an article on the Seed-coats of Malvaceæ; and Mr. Chas. Robertson continues his researches on Flowers and insects.

IN the *Journal of Botany* for March and April, Mr. E. A. L. Batters describes and figures a new marine alga, *Goniomophyllum Buffhami*, the type of a new genus. It belongs to the Deslesseriaceæ, an order of Florideæ, and is epiphytic on *Nitophyllum lacertum*, being in fact nearly allied genetically to its host-plant. It was obtained from the coast near Deal.—Mr. R. J. Harvey Gibson describes the hitherto unknown antherids of *Polysiphonia elongella*, the mode of escape and conjugation of the zoogametes of *Euteromorpha compressa*, and the mode of development of the spores of British marine species of *Chaetranzia*.—Mr. E. G. Baker continues his Synopsis of the genera and species of Malveæ; and Mr. W. H. Clarke his First records of British

<sup>1</sup> Mr. Abercromby afterwards modified this opinion (NATURE, vol. xxxix.

p. 437).—Translator.

<sup>2</sup> This statement as to the failure of the upper south-west trade-wind between the equator and lat. 35° was afterwards modified (see *Das Wetter*, 1890, p. 158).—Translator.

flowering plants.—The other articles are of interest specially to British botanists.

The *American Meteorological Journal* for February contains a carefully prepared summary of the proceedings of the International Meteorological Conference at Munich from August 26 to September 2, 1891, by A. L. Rotch. As we have already given a brief account of the Conference, and the report will shortly be published, we need not further refer to Mr. Rotch's article.—The Meteorological station of Naha, Liukiu Islands, Japan, by Y. Wada, of the Tokio Observatory. The station was established in July 1890, and is very favourably situated for the study of the typhoons of the China and Japan seas, as a great many pass near the station. As soon as the island is connected by telegraph with Kiushu it will be the most important of all the Japanese stations for storm-warnings on the coasts of China, Corea, and Siberia.—The wind-rush at Washington, D.C., on November 23, 1891, by Prof. H. A. Hazen. This violent gale was probably the most destructive that has ever been noted at that place. It passed across the city from a south or south-west direction; the wind at the Weather Bureau reached 60 miles per hour [80 miles and upwards have been recorded in this country], but the effects show that during the gusts it must have been very much greater. A cloud-burst occurred during the gale, and the water in a canal which is 25 feet wide rose about 8 feet in a few minutes. The curve showing the barometric oscillation will be found in the *Monthly Weather Review* for that month.

*Bulletin of the New York Mathematical Society*, vol. i. No. 5 (New York, February).—This number opens with a carefully drawn up account of Klein's modular functions, by F. N. Cole; the occasion being an able presentation of the theory in the work "Felix Klein: Vorlesungen über die Theorie der elliptischen Modulfunctionen, ausgearbeitet und vervollständigt von Dr. R. Fricke." Of this Mr. Cole remarks: "The clearness of treatment and skillful grouping of the many intricate features of the subject have rendered this theory now thoroughly accessible. Dr. Fricke has contributed many of the intermediate steps necessary to the symmetry and completeness of the subject." The reviewer, also a pupil of Klein, supplies many little bits of personal narrative.—The next article is an abstract by "S. N." of the periodic perturbations of the longitudes and radii vectors of the four inner planets of the first order as to the masses, computed under the direction of Simon Newcomb.—Then follows a brief sketch of solution of questions in the theory of probability and averages, by G. B. Zerr. This pamphlet forms Appendix ii. to the "Mathematical Questions . . . from the *Educational Times*."—The notes give a brief account of the Proceedings of the Society, and also contain an addendum to Prof. Hathaway's article (in No. 3), "Early History of the Potential."

*Bulletin de l'Académie des Sciences de St. Pétersbourg*, nouvelle série, t. ii., No. 2.—A preliminary communication (in German) upon the rocks collected by M. Lopatin on the Podkamennaya Tunguska. The series of Archaic rocks of Siberia, which formerly were described as dolerites, and which so constantly occur in Siberia, offer great difficulties as to their petrographical determination, well known to all geologists. The author now begins the publication of a most valuable monograph on these rocks, based upon no less than 450 samples analyzed under the microscope. The extension of these rocks is immense, as they seem to spread, with small interruptions, in the shape of an immense zone covering the space between 50° and 70° N. lat., over Siberia, North America, South Greenland, Ireland, Scotland, Norway, Sweden, and North Russia. The author describes them as "Palaeozoic traps," or typical "plagioclase-pyroxene-olivine rocks," which offer all possible gradations in their evolution. The communication being but a preliminary one, nine different "types" are described and illustrated.—On a new leucite rock from the same locality, by the same author, also illustrated by a plate.—On the Perseids observed in Russia in 1890, by Th. Breddichin (in French). The observations were made by several astronomers at Pulkova, Ostrogojsk, Kineshma, Moscow, and Libau. The weather was not favourable from August 1 to 9, and quite unfavourable on the 12th and 13th. Nevertheless, the author arrives at interesting results in comparing the centres of radiation of the meteors in 1890 with the orbit of the comet 1862 III. The centres of radiation are given on a separate plate.—Combina-

tion of the aldehydes with azoic compounds, by J. Bardilowsky (French), being an inquiry into the mechanism of the reaction between the aldehydes and the salts of aromatic amines.—Note on the heat of combination of bromine and iodine with magnesium, by N. Beketoff (French).—On Seldjuk verses, by C. Saleman (in German).—Astronomical determinations in North Russia, by O. Backlund (in German).—Remarks upon the Upper Silurian deposits of the Baltic provinces, in connection with the work of Prof. W. Dames (with a map), by Prof. Fr. Schmidt.

*Memoirs of the Kazan Society of Naturalists*, vol. xxiii., 1 to 5, and *Proceedings*.—On the tundra of the Kanin peninsula, by A. I. Jacoby, with a map. The author explored the western coast, and gives many interesting facts as to the flora of the tundra and its inhabitants.—On the biology of the *Helianthus annuus*, by A. Gordyaghin. Having discovered that the leaves of the sunflower are visited by nearly twenty different species of insects, and that some of them, especially the ants (*Myrmica lewinodis* and *Lasius niger*), suck the leaves, the author suspected the existence of "extra-nuptial" nectar—the supposition being confirmed by a similar observation previously made by Delpino; and he made experiments to ascertain whether drops of nectar do appear on the leaves. The observations have confirmed the supposition; they are being continued.—On the noxious insects of the model farm of the Kazan School, by A. Smirensky.—On the means of measuring the absorbing power of the soil, by B. Sorokin.—The Proceedings contain: a list of 300 birds of the province of Astrachan, by W. Klebnikoff; the report of a Committee nominated for the exploration of the soil in the province of Kazan; a note on the produce of a dry distillation of birch bark; and a report upon ornithological researches in the province of Kazan, with a list of all noticed birds.

## SOCIETIES AND ACADEMIES.

### LONDON.

**Zoological Society**, April 5.—W. T. Blanford, F.R.S., in the chair.—The Secretary read a report on the additions that had been made to the Society's Menagerie during the month of March 1892.—Mr. Sclater exhibited and made remarks on the heads of a pair of Swayne's Antelopes (*Bubalis swaynei*) obtained by Mr. J. W. K. Clarke and his party in Somali-land, and sent for exhibition by Messrs. Rowland Ward and Co.—Prof. F. Jeffrey Bell read a note regarding the real habitat of the Land Planarian *Bipalium kewense*, which, as it appeared, was indigenous to one of the South Pacific Islands.—A communication was read from Mr. Edgar A. Smith, on the Land Shells of St. Helena, based on a large and complete collection of the terrestrial Mollusks of that island made by Captain W. H. Turton, R.E., and deposited in the British Museum. Mr. Smith estimated the total number of truly indigenous species of this group in St. Helena to be 27, of which 7 only are now living on the island—the remainder having been exterminated by the destruction of the primeval forests.—Mr. F. E. Beddard read some notes on the anatomy of the Indian Darter (*Plotos melanogaster*), as observed in a specimen of this species recently living in the Society's Gardens.—Mr. Seeborn exhibited a specimen of a Pheasant from the valley of Zarafshan in Central Asia, which he referred to a new species, distinguishable from *Ph. principalis* by its white collar, and proposed to call it *Ph. tarnovskii*.—Mr. R. J. L. Guppy exhibited specimens of the animal, the teeth and jaws, and the shell and egg of *Bulimus oblongus*, and remarked briefly thereon.—Mr. G. B. Sowerby read descriptions of seven new species of Land-Shell from the United States of Colombia.—A communication was read from Mr. W. Schaus, containing descriptions of some new species of Lepidoptera Heterocera from Brazil, Mexico, and Peru.

**Geological Society**, March 23.—W. H. Hudleston, F.R.S., President, in the chair.—The following communications were read:—On the occurrence of the so-called *Viverra Hastingsi* of Hordwell in the French phosphorites, by R. Lydekker.—Note on two Dinosaurian foot-bones from the Wealden, by R. Lydekker.—On the microscopic structure, and residues insoluble in hydrochloric acid, in the Devonian Limestone of South Devon, by Edw. Wethered. Microscopic examination of the Devonian Limestones of South Devon shows that they have been built up by calcareous organisms, but that

the outlines of the structure have for the most part become obliterated by molecular changes, and the limestones are often rendered crystalline. In connection with this the author alludes to the disturbances which have affected the limestones. He finds occasional rhombohedra of dolomite, and discusses the probability of their derivation from magnesian silicates contained in the rocks. A description of the insoluble residues follows. The micas, the author considers, may be of detrital origin, but this is by no means certain; he is disposed to consider that the zircons, tourmaline, and ordinary rutile were liberated by the decomposition of crystals in which they were originally included. Minute crystals, referred to as "microlithic needles," resemble "clay-late needles," but are not always straight: they occur in every fine residue, and as inclusions in siliceous and micaceous flakes. The siliceous fragments which inclose them frequently contain many liquid inclusions, which does not necessarily imply any connection between the two, though there may possibly be some connection. Micro-crystals of quartz occur, and have been derived from decomposing silicates. The reading of this paper was followed by a discussion, in which Dr. Sorby, Prof. Bonney, Dr. Hicks, Prof. Rupert Jones, the President, and others took part.

April 6.—W. H. Hudleston, F.R.S., President, in the chair.—The following communications were read:—Geology of the gold-bearing rocks of the Southern Transvaal, by Walcot Gibson. The author describes the general characteristics of the rocks of the Southern Transvaal, and gives a summary of previous work on the area; he then discusses the physical relations of the gold-bearing conglomerates and associated rocks in the Witwatersrandt district, and describes the various rocks in detail. He concludes that the gold-bearing conglomerates and the quartzites and shales of the Witwatersrandt district (which have undergone considerable metamorphism) form one series, of which the base and summit are not seen; that this series is much newer than the gneisses and granites on the eroded edges of which they rest, and older than the coal-bearing beds which unconformably overlie them; that the entire series associated with the gold-bearing beds has been thrust over the gneisses, and was not originally deposited in its present position, the movements having taken place in two directions, viz. from south to north and from east to west; that, after the cessation of these movements, the strata were injected with basic and sub-basic igneous material, and much of the country was flooded with lavas of the same character; and that the conglomerates have been formed mainly at the expense of the underlying granites and gneisses, which were largely threaded with auriferous quartz-veins and contained larger masses of quartz. The author then describes the geology of districts outside the typical area, which, though at first sight more complex, are really simpler than that of the typical area. The conclusions arrived at from an examination of these areas confirm the results of the study of the rocks of the Witwatersrandt district. The reading of this paper was followed by a discussion, in which the President, Prof. Green, Mr. Attwood, Mr. Topley, Mr. Alford, Prof. Lapworth, and Mr. Teall took part.—The precipitation and deposition of sea-borne sediment, by R. G. Mackley Browne. The author discusses the mode of deposition of current-borne sediment upon the ocean-floors, and considers the effects of current-action in sifting the material and causing it to accumulate into stratified linear ridges having directions generally parallel with those of the currents—the dip of the strata varying according to the velocity of the currents. He considers that the conclusions deducible from his analysis appear to be in accord with the evidence afforded by the structure of ancient subaqueous sedimentary deposits.

Linnean Society, April 7.—Prof. Stewart, President, in the chair.—Mr. Spencer Moore exhibited and made remarks upon some samples of Maté or Paraguayan tea recently brought by him from South America.—Mr. J. Tristram Valentine exhibited a skin of Grevy's Zebra, recently brought from Somaliland by Mr. H. D. Merewether, who had purchased it from a caravan arriving from the Southern Dordbahana country, to the south-east of Berbera. Although it corresponded in the character and disposition of the stripes with the type specimen from Shoa, and with a skin in the British Museum from Berbera (P.Z.S., 1890, p. 413), it differed in the stripes being brown upon a pale sandy or rufescent ground, instead of black upon a white ground. It was suggested that this might be the desert form, the type specimen representing the mountain form.—Mr. Tristram Valentine also exhibited horns of Swayne's Hartebeest and

Clarke's Antelope (both recently described species), which, like the Zebra skin, had been lately brought from Somaliland by Mr. Merewether.—Mr. W. S. D'Urban exhibited specimens of the shell-slug *Testacella maugei* from Devonshire.—A paper was then read by Mr. D. Morris, on the phenomena concerned in the production of forked and branched palms, the conclusions arrived at being the following:—(1) Branching is habitual in certain species of *Hyphene*; occasional in others, and occasional also in the genera *Areca*, *Rhopalostylis*, *Dictyosperma*, *Oreodoxa*, *Leopoldinia*, *Phoenix*, &c. (2) Branching in many cases results from injury to or destruction of the terminal bud, causing the development of axillary or adventitious buds below the apex: these buds when lengthened out produce branches. (3) In some cases, as in *Namorphops richieana* and *Phoenix sylvestris*, branching is caused by the replacement of flowering buds by branch buds. In such cases the branches are usually short, and are arranged alternately along the stem. The terminal bud is apparently neither injured nor destroyed.—A paper by Mr. A. W. Waters, on the gland-like bodies in the Bryozoa, was, in the absence of the author, read by Mr. W. Percy Sladen.

DUBLIN.

Royal Society, March 16.—Prof. W. Noel Hartley, F.R.S., in the chair.—Prof. Haddon presented a paper by Prof. F. Jeffrey Bell on the Echinoderms collected during the Society's fishery survey of the west coast of Ireland. *Polus*, sp. juv., was recorded for the first time from Ireland (500 fathoms), *Astropecten sphenoplax*, n. sp. (500 fathoms). Amongst other rarities *Asthenosoma hystrix* was largely represented; the specimens differ so much that were it not for intermediate forms, more than one species might be described. Prof. Bell proposes to regard *A. (Caboeria) fenestratum* as a synonym of *A. hystrix*.—G. Johnstone Stoney, F.R.S., read a paper entitled "Proposed Standard Gauge, to help in appreciating the small ultra-visible quantities that have to be taken into account in studying Molecular Physics." The gauge is wedge-shaped. The base of the wedge is formed by taking Ångström's normal map of the solar spectrum, and extending its scale (the degrees of which are millimetres) both ways, till it reaches zero in one direction and 10,000 in the other. The gauge is then completed by erecting a micron or sixteenth-metre (sixtieth, the fraction represented by one in the sixth place of decimals) over the 10,000 mark and drawing the inclined plane from the top of this to the zero mark at the other end. The gauge is thus a wedge ten metres long, with a gradient of one in 10,000,000, lying upon Ångström's map; and the wave-length of any solar ray is the ordinate (the perpendicular distance from the base-line of the gauge up to its sloping top) immediately over the line representing it in the map. The wave-lengths of visible light are the ordinates of this gauge extending from 7·6 to 3·8 metres from its apex. At between 3 and 2 metres from the apex we reach an ordinate which is the *minimum visible* (the least separation between two points which will admit of their being seen as two with waves so coarse as those of light). The ordinate at one metre from the end is the seventh-metre (or metre  $\times$  000,000,1). The average distance to which the molecules of air dart in the intervals between their encounters is the ordinate at about three-quarters of a metre from the apex (*Phil. Mag.* for August 1868, p. 138). The ordinate of the gauge at 1 decimetre from its apex is the eighth-metre (or metre  $\times$  000,000,01). The ordinate at one centimetre from the apex is the ninth-metre (or metre  $\times$  000,000,001). This is about the average interval at which the molecules of a gas are spaced, when the gas is at the temperature and pressure of ordinary air (*loc. cit.*, p. 140). The ordinate at one millimetre from the apex is the tenth-metre (or metre  $\times$  000,000,000,1). This is somewhere about the "size" of a gaseous molecule, meaning by this the distance within which the centres of two molecules must come in order that an encounter may take place—that is, that they may be able sensibly to bend each other's path. It may also be taken as about the distance to which the average interval between the centres of the gaseous molecules is reduced when the gas is condensed into a liquid or solid. This is the smallest magnitude for which the gauge is proposed as convenient. Within the last-mentioned small range numerous and complicated events are known to take place, viz. all those that go on within the molecules, among which are those that originate the lines in the spectra of gases. Whenever any way of estimating these quantitatively shall be discovered, we shall want another and more acute-angled gauge to help us in appreciating them.



## PARIS.

**Academy of Sciences, April 11.**—M. d'Abbadie in the chair.—On a new determination of the latitude of Paris Observatory, by M. l'Amiral Mouchez. (See Our Astronomical Column.)—Note by M. l'Amiral Mouchez, accompanying a star photograph obtained by Dr. Gill, Director of the Cape Observatory. (See Our Astronomical Column.)—On the flow from rectangular orifices, without lateral contraction: theoretical calculation of the delivery and of its distribution, by M. J. Boussinesq.—On the absorption of light by tourmaline, by M. A. Potier.—Researches on persulphuric acid and its salts, by M. Berthelot.—On the stability of the sand dunes of the Bay of Biscay, by M. Chamberlent. A long account is given of the methods that have been adopted to prevent the encroachment of sand along the coast of the Bay of Biscay.—Note by M. Dehérain, accompanying the presentation of his "Traité de Chimie Agricole."—On a new genus of Cretaceous Echinoids, *Dipneustes aturicus*, Arnaud, by M. G. Cotteau.—Experimental study of the decimal equation in observations of the sun and planets, made at Lyons Observatory, by MM. André and Gonnessiat.—On the latitude obtained by means of the great meridian circle of Paris Observatory, by M. Périgaud.—On a series of determinations of latitude made with the great meridian circle of Paris Observatory, by M. F. Boquet.—Observations of Swift's comet (1892 March 6) and Denning's comet (1892 March 18) made with the great equatorial of Bordeaux Observatory, by MM. G. Rayet and L. Picart.—On the theory of Jupiter's satellites, by M. J. J. Landerer. (For the five preceding communications see Our Astronomical Column.)—On transformations in mechanics, by M. P. Painlevé.—On the evaluation of the numbers of permutations and complete circular arrangements, by M. E. Jablonski.—On the specific heats of metals, by M. Le Verrier. The author has measured the specific heats of lead, zinc, aluminium, silver, and copper, at various temperatures between 0° and 1000° C.—On the polarization of diffused light by disturbed media, by M. A. Hurion.—On the decomposition of silver permanganate and on a particular association of oxygen with silver oxide, by M. Alex. Gorgeu.—On some new salts of iron, by MM. Lachaud and C. Lepierre.—Action of sulphuric acid on some cyclic hydrocarbides, by M. Maquenne.—Researches on some sugar principles, by M. J. Fogh.—On the formation of oxyhemoglobin by means of hæmatine and albuminoid matter, by MM. H. Bertin-Sans and J. Moïssiessier.—Law regarding the appearance of the first epiphyseal point of long bones, by M. Alexis Julien.—On an apparatus which enables Paul Bert's experiments on air and compressed oxygen to be easily repeated, by M. G. Philippou.—Distinguishing characters of ovine and caprine species: applications to the study of *Chabins* and *Moufons*, by MM. Cornevin and Lesbre.—Halo seen at Parc de Balaine (Allier) on April 6, by M. de Montessus de Ballore.—Research on the geographical and geological conditions which characterize earthquake regions, by M. de Montessus de Ballore.

## BERLIN.

**Physiological Society, March 18.**—Prof. du Bois Reymond, President, in the chair.—Dr. Gumlich described experiments made on himself on the urinary excretion of nitrogen. He had determined separately total nitrogen, nitrogen of urea, of ammonia, and of the extractives during periods with a mixed diet, a pure flesh diet, and a vegetable diet. During the second the nitrogen excreted as urea increased until it amounted to 85.6 per cent. of the total nitrogen, and that excreted as extractives and ammonia was also greater than during a mixed diet. During a vegetarian diet the urea nitrogen markedly diminished; that of the extractives and ammonia was also absolutely less than with a meat diet, although it had increased relatively to the rest.—Dr. von Noorden communicated, in connection with the above, an extended series of determinations of urinary nitrogen made on patients suffering from different diseases; among these two cases of phosphorus poisoning were of special interest.

April 1.—Prof. du Bois Reymond, President, in the chair.—Dr. Lilienfeld had found that the influence of leucocytes on the clotting of blood is due entirely to their nuclei, the stroma being quite inert. He isolated the chemically active substance from the leucocytes of the thymus gland, and calls it leuconuclein.—Dr. Rosenbery had investigated on a dog working in a tread-mill the assimilation of a diet consisting of definite portions of lean meat, fat, and rice during periods of work and repose, and found it to be the same in both

cases. He believes the result of this experiment may be extended to the case of man.—Dr. Schweizer had investigated the behaviour of spermatozoa towards electric currents. Only in a few cases was he able to observe that some of the more active ones swam against the current. He found that the position they assumed in parallel rows with their heads turned towards the kathode was not in any way a result of their vitality.

**Physical Society, March 25.**—Prof. Kundt, President, in the chair.—Dr. Mewes spoke on emission and absorption.—Dr. Gross, in his experiments, extending over many years, on the decomposition of sulphur has recently tested it electrolytically. Barium and strontium sulphate were fused in a silver crucible, which formed one electrode, and a powerful electric current sent through the mass by means of a second electrode of platinum wire. Analyses of the products resulting from the electrolysis yielded a new compound of platinum and barium; at the same time 50 per cent. of the sulphur, originally present as sulphates, was found to have disappeared, and its place to have been taken by 40 per cent. of a new substance, which the speaker had also obtained during the electrolysis of sulphur. According to his views, sulphur is to be regarded as a compound of this new substance with hydrogen.—Dr. Budde described new experiments on the inert layer in emulsions of chloroform and soda, which confirmed him in his view that the layer is due to the rapid evaporation of chloroform from the upper surface of the mixture. A mixture of chloroform and water is even more suitable for the experiments, and, since chloroform is more soluble in cold than in warm water, he takes a solution of chloroform saturated in water at 0°, and then warms it to 20°; at the latter temperature the chloroform separates out in minute drops, yielding a perfectly opaque emulsion, while the upper layer remains clear, owing to the evaporation of the chloroform. When this upper layer is removed by a pipette it remains clear, and must therefore contain less chloroform than the lower saturated portions. The regular configuration of the inert layer in vessels of varying shape had been at one time regarded by Dr. Budde, in agreement with Liebreich, as due to capillary action. His more recent researches have, on the other hand, shown that it is due to currents in the fluid resulting from differences of temperature, and may therefore be altered at will. When the external temperature is lower than that of the fluid, downward currents are established along the walls of the vessel, upward currents in the centre of the fluid, and the meniscus is convex: when the external temperature is higher, the reverse effect is produced, and the meniscus is concave.

April 8.—Prof. du Bois Reymond, President, in the chair.—Dr. Lammer gave an account of alterations made by him, in conjunction with Dr. Brodhan, on a spectrophotometer, with a view to improving the photometric part of the instrument by the introduction of his glass-cube. In connection with the above, Dr. Lammer went very fully into Prof. Abbe's theoretical researches on the delineation of non-luminous objects, which had been made during the latter's studies on the mode of action of microscopes, and transferred the results arrived at by Abbe to the conditions existing in a spectrophotometer.

**Meteorological Society, April 5.**—Prof. Schwalbe, President, in the chair.—Dr. Sprung spoke on atmospheric rings, and explained the formation of solar and lunar rings as the result of refraction of parallel solar rays in ice-prisms. The prisms must be three-sided, and the maximal intensity of light is obtained when the angle of entry and exit from the prism is 22°, in which case the deviation is minimal. Solar and lunar halos are the result of the bending which light undergoes at the edges of minute ice-particles. The phenomenon can be observed by strewingycopodium powder on a sheet of glass, and looking at a flame through this film. The speaker further exhibited some photographs of rings and halos, explained the conditions which are necessary for their successful production, and gave the formulæ involved in the calculation of the phenomena.—Dr. Schumbert made a communication in connection with Dr. Lachmann's (see report of previous meeting), and gave a synopsis of temperature maxima and minima observed at woodland stations, both in the woods and just outside them. Some interesting differences were observed, depending upon the kind of trees and the position of the thermometer. After some remarks by Dr. Lachmann on a paper by von Bebbin in *Himmel und Erde* on the same subject, Dr. Hofmann in conclusion exhibited an apparatus for registering the observation of meteors.

## AMSTERDAM.

**Royal Academy of Sciences, April 2.**—Prof. van de Sande Bakhuyzen in the chair.—Mr. Kapteyn communicated the result of a discussion of a great part of the photographs taken at the Cape Observatory under the direction of Her Majesty's Astronomer, D. Gill. The diameters of the stars on 370 of these photographs, covering an area of nearly 9000 square degrees of the sky, have been compared to the visual magnitudes of these stars according to the estimations of Messrs. Gould and Schönfeld. It is shown that for stars of equal visual brightness the actinic effect on the plates has been considerably greater for the stars situated in or near the Milky Way, than for stars situated in considerable galactic latitudes. The different causes that may have co-operated to produce this phenomenon have been carefully considered, and the conclusion is arrived at, that neither influences of meteorological causes, nor causes of systematically different sensitivity of the plates, are sufficient to account for it; and that the systematic errors in the estimations of the visual magnitudes are, in all probability, of secondary importance. It seems very probable, therefore, that the principal cause must be sought in peculiarities of the light of the stars themselves. The fact discovered by Mr. Pickering, that the Milky Way must be considered as an aggregation of stars of the first type explains only a small fraction (not 0.1 mag.) of the differences found. Mr. Kapteyn therefore thinks that we are driven to the conclusion that the light of the stars of the first type in the Milky Way is considerably richer in violet rays than the light of stars of the same type in great galactic latitudes. From this would follow, according to the researches of Mr. Pickering, that the same must hold for stars of the other spectral types. In the meanwhile direct photometric and photographic experiments seem very desirable, in order to prove the reality of the phenomenon by more direct evidence than is contained in the plates of the Photographic Survey. Such experiments have been already undertaken by the Cape Observatory.—Mr. Hübrecht gave an account of the placentation of certain Lemurs and Insectivora, as a result of his recent excursion in the Indian Archipelago. The placenta of *Tarsius spectrum* is a discoid one, and differs from that of other Lemnroids hitherto known, in which a diffused distribution of villi over the whole surface of the chorion has been observed. In *Nycticebus* this coating loses its villous character at one pole of the egg in the latest stages of pregnancy. Certain stages of the discoid placenta of Galeopithecus were further described, as was also the double placenta of *Tupaja javanica*, each placenta having a reniform shape, these being situated right and left of the embryo, which has its ventral surface turned towards the mesometrium.—Mr. Pekelharig reported on his further investigations about the coagulation of the blood. He states that the A. fibrinogen of Woolldridge is the same substance which can be precipitated from the diluted plasma by acetic acid, viz. a nucleo-albumin, the zymogen that, by combination with lime, forms fibrin ferment. Woolldridge's tissue-fibrinogen is also a nucleo-albumin from which can be obtained, by treating it with lime-salts, fibrin ferment. In accordance with Dr. Wright, Mr. Pekelharig has found that, in the dog and in the rabbit, an albumose can be split off from the nucleo-albumin, and in this manner the formation of the fibrin ferment can be prevented, or the action of the ferment already formed can be paralyzed.

## DIARY OF SOCIETIES.

## LONDON.

## THURSDAY, APRIL 21

LINNÆAN SOCIETY, at 8.—On some New Plants from China: W. B. Hensley, F.R.S.—On the Relation of the Acaridæ to the Arachnida: H. M. Bernard.

CHEMICAL SOCIETY, at 8.

## FRIDAY, APRIL 22.

INSTITUTION OF CIVIL ENGINEERS, at 7.30.—The Speed and Power of Locomotives: Edmund L. Hill.

## SATURDAY, APRIL 23.

ROYAL BOTANICAL SOCIETY, at 3.45.

## MONDAY, APRIL 25.

ARISTOTELIAN SOCIETY, at 8.—Prof. Wm. James's Treatment of Self: G. Dawes Hicks.

## TUESDAY, APRIL 26.

ANTHROPOLOGICAL INSTITUTE, at 8.30.—The Social and Religious Ideas of the Chinese, as illustrated in the Ideographic Characters of the Language: Prof. R. K. Douglas.—The Mythology and Psychology of the Ancient Egyptians: Joseph Offord, Jun.

ROYAL STATISTICAL SOCIETY, at 7.45.—An Inquiry into the Statistics of the Production and Consumption of Milk and Milk Products in Great Britain: R. Henry Rev.

INSTITUTION OF CIVIL ENGINEERS, at 8.—Electric-Light Measuring Instruments: James Swinburne.

PHOTOGRAPHIC SOCIETY, at 8.

ROYAL INSTITUTION, at 8.—The Sculpturing of Britain—its Later Stages: Prof. T. G. Bonney, F.R.S.

## WEDNESDAY, APRIL 27.

GEOLOGICAL SOCIETY, at 8.—Notes on the Geology of the Northern Ethal or Eastern Desert of Egypt; with an Account of the Emerald Mines: Ernest A. Floyer.—The Rise and Fall of Lake Tanganyika: Alex. Carson. (Communicated by R. Kidston.)

ENTOMOLOGICAL SOCIETY, at 7.

BRITISH ASTRONOMICAL ASSOCIATION, at 5.

## THURSDAY, APRIL 28.

ROYAL SOCIETY, at 4.30.

INSTITUTION OF ELECTRICAL ENGINEERS, at 8.—Notes on the Light of the Electric Arc: A. P. Trotter.

ROYAL INSTITUTION, at 3.—The Chemistry of Gases: Prof. Dewar, F.R.S.

## FRIDAY, APRIL 29.

INSTITUTION OF CIVIL ENGINEERS, at 7.30.—The Steam-Hammer and its Relation to the Hydraulic Forging-Press: H. H. Vaughan.

ROYAL INSTITUTION, at 9.—The Physiology of Dreams: Dr. B. W. Richardson, F.R.S.

## SATURDAY, APRIL 30.

ROYAL INSTITUTION, at 3.—J. S. Bach's Chamber Music (with many Musical Illustrations): E. Dannreuther.

## BOOKS, PAMPHLETS, and SERIALS RECEIVED.

BOOKS.—Blowpie Analysis, 2nd edition: I. Landauer; translated by J. Taylor (Macmillan).—Air Comprimé ou Rarefié: A. Gouilly (Paris, Gauthier-Villars).—La Distribution de l'Électricité, Installations Isolées: R. V. Picou (Paris, Gauthier-Villars).—Résistance des Matériaux: M. Dugesme (Paris, Gauthier-Villars).—Machine à Vapeur: V. Delschamps-Dery (Paris, Gauthier-Villars).—Elements of Materia Medica and Therapeutics: C. E. A. Siple (Longmans).—Fruit Culture: J. Heal (Bell).—My Water-cure: S. Knepp (Grevel).—Color-vision: E. Hunt (Simpkin).

PAMPHLET.—On the Physics of Media: J. J. Waterston (Kegan Paul).  
SERIALS.—The Asclepiad, No. 33, vol. ix. (Longmans).—Geological Magazine, April (K. Paul). Journal of the Royal Agricultural Society, 3rd series, vol. iii. Part 1 (Murray).—Himmel und Erde, April (Berlin, Paetel).—The Annals of Scottish Natural History, No. 2 (Edinburgh, Poulton).—Journal of the Institution of Electrical Engineers, No. 99, vol. xxi. (Spott).—The Eagle, March (Cambridge, Johnson).—Journal of Anatomy and Physiology, vol. xxvi. Part 3 (Williams and Norgate).—Mind, April (Williams and Norgate).—Massachusetts Institute of Technology, Boston, Annual Catalogue, 1891-92 (Boston).—Journal of the Royal Statistical Society, March (Stanford).—Journal of the Chemical Society, April (Gurney and Jackson).—Bulletin de l'Académie Impériale des Sciences de St. Pétersbourg, nouvelle série, ii., xxxiv., feuilles 34-41.—The Engineering Magazine, April (New York).

## CONTENTS.

	PAGE
The Yahgan	577
Quantitative Analysis. By J. W. R.	578
Astronomy	579
Our Book Shelf:—	
Cheal: "Practical Fruit Culture"	579
Landauer: "Blowpie Analysis"	580
Letters to the Editor:—	
Presthistory of Egypt.—W. M. Flinders Petrie	580
Aphanapteryx in the New Zealand Region.—Prof. Henry O. Forbes	581
Pigments of Lepidoptera.—F. Gowland Hopkins	581
C.G.S. System of Units.—O. H. Tittmann; Prof. J. D. Everett, F.R.S.	581
Influenza in America.—Prof. Edward S. Holden	582
Dust Counting on Ben Nevis. By Angus Rankin	582
Abstract of Mr. A. Ricco's Account of the Submarine Eruption North-west of Pantelleria, October 1891. (Illustrated.) By G. W. Butler	584
Giraffes	585
Notes	585
Our Astronomical Column:	
Astronomy at the Paris Academy, April 11	589
Solar Heat	589
Periodic Variations in Latitude	589
Recent Advances in Physical Chemistry. By Prof. W. Ostwald	590
The General Circulation of the Atmosphere. By Dr. J. M. Pernter	593
Relation of V. Italic Electromotive Force to Molecular Velocity. By Dr. G. Gore, F.R.S.	596
Scientific Serials	596
Societies and Academies	597
Diary of Societies	600
Books, Pamphlets, and Serials Received	600

THURSDAY, APRIL 28, 1892.

## THEORETICAL CHEMISTRY.

*Outlines of Theoretical Chemistry.* By Lothar Meyer, Professor of Chemistry in the University of Tübingen. Translated by P. Phillips Bedson, D.Sc., and W. Carleton Williams, B.Sc. Pp. 220. (London: Longmans, Green, and Co., 1892.)

"GOOD wine needs no bush," but a well-known bush makes one look for good wine. The translation of Prof. Lothar Meyer's "Die Modernen Theorien der Chemie," made by Messrs. Bedson and Williams, is so well known and so appreciated by all English-speaking chemists, that everyone welcomes a new book by the author of "Modern Theories," and expects the book to be a good one. The "Outlines of Theoretical Chemistry" is a translation, by the translators of the "Modern Theories," of a book published in German in the course of last year. The translation is exceedingly well done; the English runs smoothly and lucidly; the book reads as if it were composed in English, rather than as a translation from another tongue.

The subject-matter of this book is very similar to that of "Modern Theories"; details are avoided wherever the author thought this could be done with advantage, and the treatment is made as general as possible. In his preface to the English translation the author says:—

"The general—I may say the philosophical—review of the subject has been my chief aim, to which the details should be subordinated."

The book is not divided into chapters, but runs on from paragraph to paragraph. Beginning with a statement of the province of chemistry, the author passes in review the stoichiometric laws, sketches the atomic hypothesis, considers the various aspects of chemical equivalents, states and applies the law of Avogadro, refers to Prout's notions about the relations between the values of atomic weights, and states and briefly illustrates the periodic law; he then considers in several paragraphs the constitution of compounds in the light of the molecular and atomic theory, and, through a short discussion of physical isomerism, he passes to the consideration of such physical properties of bodies as melting and boiling point, capillarity, solubility, evaporation, &c., and the connexions between these and the molecular weights and constitutions of bodies. Finally the author devotes some fifty or sixty paragraphs to the treatment of the thermal and electrical aspects of chemical changes, and the subject of chemical affinity.

At the outset the essential character of chemical phenomena is emphasized:—

"Chemistry deals with the changes which affect the material nature of the substance. Chemistry, then, is the science which treats of matter and its changes" (p. 2).

It is to be wished that all writers of books, whether elementary or advanced books, on chemistry, and all who endeavour to help others to learn this science, would keep steadily before them the characteristic feature of all chemical events, viz. that they are those which occur

when changes of composition accompany changes of properties in definite kinds of matter. If this were done we should not be deluged with those catalogues of the properties of innumerable disconnected substances which are frequently sold under the misleading name of textbooks of chemistry.

The paragraphs on the determination of atomic weights from stoichiometric values (pp. 11–13) seem to me extremely lucid and apposite, provided the reader will give his close attention to them. I do not think the subject of chemical equivalents is treated sufficiently fully to make it clear (pp. 13–16). Paragraph 13 does not make perfectly intelligible the process whereby atomic weights are determined from the crystallographic relations of compounds. I am much taken by the order in which the author arranges his treatment of combining weights, equivalents, thermic equivalents, crystallographic equivalents, &c., culminating in Avogadro's law. The determination of atomic weights by the application of the law of Avogadro is made very clear in a couple of paragraphs (pp. 39–42); and the author is especially to be congratulated, in my opinion, on paragraph 26, wherein he most skilfully and gracefully avoids the popular error of making a stumbling-block of so-called "abnormal vapour-densities."

Paragraph 28, which deals in about thirty lines with "nascent state," would much better have been omitted; the treatment is neither interesting nor accurate. It seems to me that paragraphs 34–40, which are supposed to give a clear general conception of the periodic law, quite fail to enable the student to grasp this all-important generalization. I think that much too little space is given to the periodic law, which comprises in itself all other schemes of chemical classification; and that too much space is devoted to valency, which, at the best, is a conception that is of very limited application. Anyone who turns from the study of Mendeleeff's great work on "The Principles of Chemistry" to the paragraph on p. 76 will be greatly astonished; the paragraph reads thus:—

"Formerly it was more or less explicitly assumed that a chemical compound was held together by the total attractive force of the affinities of all the atoms contained in it; but, as our knowledge increased, it was gradually recognized that the connexion is between atom and atom, and that the atoms are attached to each other like the links in a chain, the continuity ceasing if even a single link of the chain is removed."

This sentence seems to imply that no one now looks on a molecule as held together by the interactions between all the atoms; but if one says this view is held by none, one must make a few exceptions, such as Mendeleeff and the chemists of his school. The treatment of atomic linkage on pp. 80–83 seems to me to be very one-sided and unsatisfactory. We are told (p. 81) that such a formula as  $H_2O \cdot SO_3$  is inadmissible because it represents the compound as made up of atomic groups which are already saturated, and "therefore have no free affinities for mutual combination"; but on p. 107 we are informed that, in substances which crystallize with water, "every molecule is united with a definite number of molecules of water." But how can water molecules unite with, say, dehydrated alum, if the group  $H_2O$  is saturated and "has

therefore no free affinities"? This example shows that the paragraph quoted above from p. 76 is much too dogmatic.

I do most strongly object to such a statement as that on p. 69, where, speaking of carbon monoxide, it is said:—

"The molecule of this compound is represented by the formula



Here the asterisks are intended to show that two affinities are unsaturated; this is proved by the fact that the compound unites with two atoms of chlorine, forming phosgene gas,



What is proved by the fact of combination with chlorine? No one can attach any clear meaning to the statement "two affinities are unsaturated." The only practical meaning these words have is, "The molecule CO can unite with two other atoms of certain kinds"; that is to say, the sentence quoted, when put into the speech of the plain man, asserts that the fact that CO does unite with 2Cl proves that CO can unite with 2Cl.

The later paragraphs, treating of the physical properties of bodies and the connexions between these and the constitutions of the same bodies, seem to me to be both very well done and very disappointing. They are well done because an earnest attempt is made to put the matter clearly, but they are disappointing because it is quite impossible to grapple with these very difficult matters in the space which is given to them in this book. I do not think that anyone will succeed in getting a grasp of Raoult's law from the pages which are grouped around paragraph 133. The application of Raoult's law to determine molecular weights, given on p. 137, is based on the constant '62°, which has been shown by van 't Hoff and others to be erroneous.

But it is much easier to find fault than to compose such a book as this. A careful perusal of the work leaves the impression on my mind that, as a synopsis and suggestive remembrancer to the student who knows general chemistry well, this book will prove useful, but that it is too condensed and too slight to be of much service to him who is beginning the study of general chemistry. Most of the subjects dealt with cannot be made clear except by going into details, and illustrating them with considerable profusion. When one attempts to deal with these matters in a broad and general way, and at the same time to devote only a few pages to each section, one is almost obliged either to make statements so generalized that they are of very little use to the earnest student, or only to touch the fringe of each part of the subject. Chemistry is an abstract science to a much less degree than physics; hence such short statements as those which sum up and include in themselves whole provinces of physical knowledge cannot yet be made in chemistry. Where the "Outlines of Theoretical Chemistry" fails for the most part it fails because no book could succeed; it fails because it attempts to do that which cannot, at present, be done.

M. M. PATTISON MUIR.

### THE TRAVELS OF A PAINTER OF FLOWERS.

*Recollections of a Happy Life, being the Autobiography of Marianne North.* Edited by her sister, Mrs. John Addington Symonds. In Two Volumes. (London: Macmillan and Co., 1892.)

MOST of the readers of NATURE will know without telling that Marianne North was a world-wide traveller, that she travelled in pursuit of nature, that she was an accomplished and faithful painter of plant and animal life, and that the results of a life's labour were presented by her to the nation, and now cover the walls of a building in Kew Gardens, erected at her expense. Most persons, too, who knew her personally—and her acquaintances and friends are as numerous as her travels were wide—will be glad to know something more of her history, and especially something more of her travels, of her impressions of peoples, of places, and, above all, her impressions of the plant and animal life of the many countries she visited and to which she gave her life. All who had the pleasure of knowing her personally will remember her stately presence, her kind face, her charming manner, and her entertaining conversational powers—now relating the difficulties and delights of her experiences in foreign lands, now her appreciation of home comforts and genial society. She wrote as she talked, and she was a fertile letter-writer; and she has written her book in the same style.

In early life Miss North made various journeys in Europe, and also went up the Nile and visited Syria, and painted many flowers; but with the exception of the Sicilian *Papyrus*, and perhaps two or three other little pieces, none of this early work is in the gallery at Kew. Only 38 pages of her book are devoted to her early life, and it practically begins with her more distant travels; the first long trip being to Canada and the United States, and extended to Jamaica, whence she returned to England. Two months later she started for Brazil, where she made a long stay, and then returned direct to England. The next journey included Teneriffe, California, Japan, Singapore, Borneo, and Java, and then home again. Her paintings attracted attention, and she complied with a request to exhibit some 500 of them at Kensington. This matter being arranged, she proceeded to India, landing on the way at Lisbon, Gibraltar, Malta, and Galle; and India was traversed almost from east to west and north to south.

The narrative of this journey is perhaps the most interesting part of the whole work. On her return home there was an exhibition of the accumulated paintings in Conduit Street; and a visit to Mr. Darwin, which ended in a determination to go to Australia and paint the flowers of the fifth quarter of the globe. It should be mentioned that in the meantime Miss North had adopted a suggestion of the *Pall Mall Gazette* that her paintings should find their home at Kew, and her generous offer was accepted. So it was, that when Darwin told her that her collection of paintings would be an imperfect representation of the vegetation of the world without the Australian element, she took it as a "royal command," and prepared to go forthwith. This journey some of the old scenes were revisited, brief halts being made at Galle and Singapore, a longer stay with the Rajah and Rani

Brooke in Borneo, and thence to Queensland. New South Wales, Victoria, West Australia, Tasmania, and New Zealand were successively visited; but incessant travelling, climatal changes, and continuous work had begun to tell on the constitution of this brave woman, who suffered much in the colder regions. Now, the great object was to make the collection of paintings as complete as possible, and she spared neither her pocket nor her person in trying to carry it out. Her book is so essentially the history of her gallery at Kew that one cannot dissociate them. The Australian journey was fruitful beyond all others, and the Australasian section of the gallery is perhaps the most attractive of all, being a marvellously complete representation of the varied and curious flora of that region. The homeward route was across the Pacific, calling at Honolulu, landing at San Francisco, and off at once to the redwood and mammoth-tree forests for more painting. Then across America by the southern route, and back to old haunts in the North-Eastern States, and home again to open the gallery, which had been built during this journey. Hanging the pictures was a most laborious task, from which Miss North took no rest. At this time the writer first made her acquaintance, and was engaged by her to botanize the paintings and compile a popular instructive catalogue. This occupied two or three months; and most interesting work it was, usually brightened by her presence.

No sooner was the opening of the gallery accomplished, than the terribly jaded donor of this munificent gift to the public began to think of visiting new regions to further enrich it. But I must be brief, for even to catalogue these journeys occupies much space. South Africa was next visited, and several months' uninterrupted work, much of it done under trying conditions of failing health, yielded so bountifully that it was determined to build a wing to the gallery, for the existing walls were already completely covered.

Miss North intended going from South Africa to Madagascar, but the means of communication were irregular and uncertain, and her health so bad that she returned home; but having to some extent recovered, she went the following year (1883) to the Seychelles, to paint the beautiful palms and screw pines of those islands. Even this did not satisfy her, and she started on her last journey in November 1884. Chili was her goal, and the principal object of this long journey was to paint the *Araucaria imbricata* in its home, as she had already painted the Brazilian and Australian species. She also succeeded in painting a considerable number of the characteristic types of the vegetation of that country. But this voyage, by way of the Straits of Magellan, tried her waning strength very much, and a less energetic person would have collapsed entirely. In the last chapter of her "Recollections" we read that all was enjoyment until they reached Bordeaux. "Then my nerves gave way again (if they were nerves), and the torture has continued more or less ever since." Beautiful Rio was touched on the outward voyage, and on the homeward route, by Panama, old friends were looked up in Jamaica. England was reached in the spring, and it cost another year to rearrange the gallery; the introduction of the South African, Seychelles, and Chilian paintings entailing renumbering throughout, in order to preserve the geographical order.

The foregoing is an outline of her journeyings, but the book should be got for the details, which are almost always interesting, often clever and quaint. Here and there one meets with uncompromising criticisms and descriptions of persons that might have been expunged with advantage. The descriptions of the vegetation of various regions, with particulars of the principal elements, are pleasant and instructive, often containing much original information; and will be greatly appreciated by those who frequent the gallery at Kew, of which the book, as already stated, contains the history.

After completing her work at Kew, Miss North took an old-fashioned house at Alderley, in Gloucestershire, where she formed a charming garden; but her constitution was broken, her sufferings increased, and she died in August 1890. W. B. H.

#### AMERICAN TOWN TREES.

*Our Trees.* By John Robinson. (Salem: Horton and Son, 1891.)

THIS short account of the trees of an American town and its neighbourhood consists of reprints of newspaper articles written in 1890-91 for the benefit of local readers: they have been re-compiled into book form at the request of the directors of the Essex Institute, and date from the Peabody Academy of Science, Salem.

Several points strike a careful reader of the book. The writer draws special attention to the fact that the articles, or chapters, are not intended as botanical essays; and the reader will probably decide that the remark was unnecessary, for a more unscientific work dealing with a scientific subject would be difficult to find; but there is a peculiar charm in a certain style of talks about natural objects—for instance, in some of the more chatty paragraphs of White's "Selborne," or Walton's "Angler," and even Evelyn's "Flora"—which attracts the most devoted student to refreshing looks around his subject-matter from every-day points of view, and this little work possesses that charm. Few facts of scientific importance are met with in such writings, and still fewer of the generalizations which make science what it is: the specialist may even deride the writing as "talker-talker"—gossip, if you will; and even the broadest thinker may be inclined to wonder why such articles are written; all this, and more, may be true, and yet—there is the charm, nevertheless, and it is very apt to seem appropriate where trees and flowers are concerned. Whether it is advisable that such writings should increase is a matter likely to settle itself, simply and certainly, because very few can produce them. A scientific work, then, this is decidedly not. It is a series of homely chats about trees, by one who knows and loves them. The latter fact leads to another—namely, that such a writer cannot help telling you something worth learning even though it be by the way, and merely incidental.

In the first place we gather some ideas as to what trees are common in the streets and gardens of a Massachusetts town, and the evidently thriving condition of magnolias, sumachs, maples, witchhazels, mulberries, hickories, gingkos, catalpas, sassafras, and many other beautiful trees, makes envious one who knows what difficulties are

met with in this country in attempts to rear even presentable "specimens" of such favourites in our smoke-bladen and crowded cities and suburbs.

Then, again, the English reader gathers some information as to the Western popular names of trees, well known to him by very different ones; how many English people know what are the "cucumber-tree," the "yulan," the "buckeye," the "butter-nut," and the "button wood"?

Bits of history also occur, and incidental notes on the rates of growth of various trees, their ages, &c. So that, after all, there are some dry facts in this singularly quaint and simply written talk about trees. We must not claim much for the work in this respect, however; and perhaps the chief reason we like the writing is because of its contrast to the empty and inflated style of too many of our native newspaper articles on similar subjects.

### OUR BOOK SHELF.

*Synopsis of Non-Metallic Chemistry.* By William Briggs, B.A., F.C.S. Pp. 90. (London: W. B. Clive and Co.)

THIS book is intended for students preparing for the Matriculation Examination of London University. After the contents of an ordinary text-book have been studied, the reader is here supposed to find the more important points which have to be remembered, and which serve to recall the less important. Interleaved note-paper is provided, whereon facts readily forgotten may be recorded.

As is usually the case with such cram-books, little can be said in favour of the quality of the information supplied.

Formulæ are stated to be "arrangements of letters representing a *molecule* of a compound," and this definition is illustrated by regarding  $\text{Fe}_2\text{O}_3$  as denoting a molecule. The vapour-density of hydrofluoric acid is given as 10, and the solubility of hydrogen in water as "practically the same at all temperatures from  $1^\circ$  to  $20^\circ$ ": neither statement is up to date. Such antiquated terms as *basyulous* and *chlorous*, which are freely employed, might well be replaced; and to speak of *distilling* potassium perchlorate with strong sulphuric acid is inaccurate. The account given of fractional distillation is worthy of reproduction. The mixture of liquids is heated "up to the lowest of the boiling-points of the liquids present. The whole of that liquid (?) will be converted into vapour, and can be condensed in the usual way. On heating the remaining liquid up to the next boiling-point, we can separate another of the constituents, and so on until they are all separated out. The different liquids thus obtained must be redistilled to get them quite free from the others, small quantities of which may have been distilled over in the first process."

This last extract is typical of the bulk of the knowledge contained in the book, which, to say the least, savours more of the class-room than the laboratory.

A table of contents, a glossary, and three appendixes are provided. The last are concerned with the preparation and purification of substances and with the simpler chemical calculations. A list, with answers, of numerical examples set at the matriculation examinations is included.

*Chemical Calculations.* By R. Lloyd Whiteley, F.I.C. With a Preface by Prof. F. Clowes, D.Sc., F.I.C. (London: Longmans, Green, and Co., 1892.)

THIS is still another addition to the numerous manuals on chemical arithmetic, and the points wherein it differs from its predecessors are somewhat difficult to discover.

Once more we have specific gravity observations in which corrections for temperature and air displacement are ignored; and although the author attempts to set right the prevalent misconception as to the meaning of density and specific gravity, it is questionable if he succeeds. According to him, specific gravity is always relative; it is the same magnitude as relative density. The use of absolute specific gravity—or, shortly, specific gravity with no temperatures of comparison attached—as denoting the weight of unit volume, is here overlooked. From a physical point of view, the definition of the absolute density of a gas as the mass of 1116 litres is a needless complication. In ascertaining the percentage composition of a compound it is insisted that, first of all, the *molecular* weight must be calculated. The examples given to illustrate the rule include apatite, apophyllite, basic lead chromate, &c. The student is thus led to infer, here as elsewhere in the book, that the molecular weights of such bodies can be fixed.

The freezing-point and boiling-point methods of obtaining molecular weights are disposed of in two pages. No hint is given that the solutions must be dilute and non-electrolytic, if consistent results are to be obtained; or that, in general, the interpretation of the results of these methods is still subject to difference of opinion.

It is erroneous to state that "the alteration in the volume of a gas is proportional to the so-called absolute temperature," or to speak of "Dalton and Henry's law." Henry's law is distinct from Dalton's, and is the older by two years.

We have dwelt on some of the points which seem to call for criticism. On the other hand, the book has its good features. The problems are numerous, carefully selected, and well arranged. Contents, answers, and index are supplied. It seems to us, however, that, instead of being as good as several of its kind already in existence, it, as a new book, should have been better.

*The Year-book of Science.* Edited for 1891 by Prof. T. G. Bonney, D.Sc., LL.D., F.R.S. (London: Cassell and Co., 1892.)

ALL who have any sympathy with scientific pursuits will heartily welcome the appearance of this epitome of the more important results of the investigations which were published during the past year. Scientific inquiry now covers so much ground that all men of science must be more or less specialists, and it is difficult for them to keep in touch with the developments in other branches through the usual channels, although it frequently happens that an advance in one subject may throw light upon and induce investigations in another. There are also many engaged in practical pursuits who require a convenient means of determining how far contemporary researches may be technically applied.

With a well selected staff of contributors, the editor has attempted to meet the wants of all by the present volume, which is divested as far as possible of technicalities. The scope of the work is sufficiently defined by the following paragraph from the editorial:—

"It is almost needless to remark that this volume is not intended to be a record or catalogue of papers. The endeavour of its projectors and compilers has been to select those memoirs, in each several department, which appeared to be of somewhat exceptional interest, either by throwing light on special difficulties or by being suggestive of further advances."

In a work of this kind strict impartiality is essential, and we see no reason to suppose that the various contributors have abused the power vested in them. On the whole, the production is very satisfactory, and the improvements which the editor contemplates for the next volume will make it more so. One can only wonder that science has had to wait so long for a year-book of its own.

*Handy Atlas of Modern Geography.* (London: Edward Stanford, 1892.)

It would be difficult to obtain a small atlas more complete than this. Every place of any importance appears to be represented on one or more of the thirty coloured maps. The degrees of latitude and longitude are subdivided into parts of five minutes each, so that the positions of places, the names of which are not engraved, can be easily and accurately located by reference to the alphabetical list at the end. This list is a comprehensive one. It gives the latitude and longitude of the principal mountains, rivers, capes, bays, islands, towns, and villages, and forms an excellent supplement to a very good atlas.

#### LETTERS TO THE EDITOR.

(The Editor does not hold himself responsible for opinions expressed by his correspondents. Neither can he undertake to return, or to correspond with the writers of, rejected manuscripts intended for this or any other part of NATURE. No notice is taken of anonymous communications.)

##### Aurora.

A VERY brilliant display of aurora was seen here last night, the 25th inst. At about 9.25 p.m. a number of red streamers proceeded from a length of some 110° in azimuth along the northern horizon, and extended upwards for (on an average) 30°. The length of the streamers varied quickly, sometimes shooting upwards for 70° from the horizon. In the course of five minutes the red streamers gave way to white or yellowish white ones, narrower and more sharply defined than the red ones. At 9.40 p.m. there was a decrease in the brilliancy of the phenomenon, but at 9.45 p.m. long red streamers again appeared for a few minutes, which again shortly gave way to a brightness of the horizon only. Close to the horizon the colour was white, or nearly so, the whole time. The apparent point of convergence of the streamers was far south of the zenith, say 30°.

Geo. M. SEABROKE.

Temple Observatory, Rugby, April 26.

PROBABLY many of your readers witnessed the brilliant display of the northern lights between nine and twelve o'clock last night, the 25th, but it may be as well to call attention to it, as being the finest display seen here for many years. Appearing soon after nine o'clock, the luminous arc and the radiating beams, sometimes rose and orange coloured, presented a varied and beautiful spectacle until close upon midnight, when they faded away.

The most noteworthy features of this display were the vividness and height of the arc, which reached an angle of about 13° above the horizon, whilst the beams were visible up to 51°. The whole expanse of the arc from east to west was about 93°, and the duration of the phenomenon a little under three hours.

ARTHUR MARSHALL.

Cauldon Place, Long Row, Nottingham.

A FAIRLY distinct aurora was visible here on the northern horizon last night. I first observed it at 9.15, when the streamers appeared somewhat less bright than the Milky Way. Ten minutes later one streamer, about 15° west of north, brightened considerably, and appeared of a pale reddish-yellow tint. It fluctuated in intensity, and soon became less bright. The streamers, which inclined slightly to the west of the vertical, extended to about 30° to 40° above the horizon.

I watched them till 9.50, when they seemed fading in intensity, and when I looked again at 10.30 they had disappeared entirely.

ARTHUR E. BROWN.

Thought Cot, Brentwood, April 26.

##### Pigments of Lepidoptera.

THE appearance of Mr. F. Gowland Hopkins's letter on this subject in the last issue of NATURE (p. 581) demands a brief explanation from me—although it is not easy to reply satisfactorily within narrow limits—and the more so since Mr. Hopkins appears to have somewhat misunderstood my standpoint.

Let me first acknowledge the courteous tone of Mr. Hopkins's letter, and express my sense of the value to myself of criticism from his pen, and the more so since I have been labouring under the disadvantage of being practically entirely uncriticized so far—a disadvantage that I have not failed to appreciate.

Now, Mr. Hopkins remarks: "Mr. Coste's experiments are very useful as forming a method of classifying these pigments; but . . . they are of far too empirical a nature for any considerations as to the constitution of the bodies to be based upon them."

Here it is that Mr. Hopkins appears to have missed the point of my work. If he will do me the favour to refer to the detailed account of my experiments in the *Entomologist*, *passim*, I think that he will find it tolerably clearly emphasized that my interest in this work, so far, has been almost entirely *biological*. I stated expressly in my opening article that my object had been to discover, if possible, the genealogies of the colours, and to obtain evidence (so far as coloric characters could afford it) of the phylogenetic relations of allied species: and I may perhaps add that the results obtained have enabled me to predict several varieties of whose occurrence in the natural state I have since been informed. So that Mr. Hopkins is mildly reproaching me because my work does not tend in a direction at which it was not originally aimed, while he is at the same time good enough to admit that it is of some use for the end at which it was aimed.

However, it was only to be anticipated that one could not go very far without becoming involved in the further question as to the constitution of the pigments; but here I was met by three considerations. In the first place, I was anxious to obtain first of all as much as possible of what Mr. Hopkins designates "empirical" evidence as to the reactions and classification of the pigments before making any researches at all into their constitution; secondly, the amount of material at my command was far too scanty for any even approximate analysis; and in the third place, shortly after my experiments had been commenced, my attention was drawn to an abstract of a paper by Mr. Hopkins on the constitution of the yellow pigments. Finding that he was already in possession of the field here, I felt almost bound to leave this part of the subject alone, at least for the present; and I think that I may say that I have on the whole taken exaggerated care not to extend my experiments into that quarter where Mr. Hopkins was engaged, or to avail myself of the discoveries that he had already made, in order to trespass on his investigations. Putting aside my provisional suggestions as to the nature of the "reversion effect," it has only been at a comparatively recent stage of my work, and in consequence of experiments that have not yet been published, that I have at all turned my attention to the constitution of the pigments; these results being such as would have compelled me to consider the question even had I heard nothing of Mr. Hopkins's work. I hope that this explanation will put me right in Mr. Hopkins's eyes, and will satisfy him that he has considerably misunderstood the spirit of "some remarks [perhaps clumsily expressed by me] made at the close of the last article"; and that it will also satisfy him as to the question of priority. I had no thought of questioning Mr. Hopkins's priority in his own work, and the less so since I have throughout been under the impression that we were working mainly on different—though sometimes adjacent—lines.

I must not so far trespass upon your space as to criticize Mr. Hopkins's criticisms upon the "reversion effect"; but I will ask him kindly to examine the detailed accounts of the "reversion" experiments which I gave in the *Entomologist*, since his remarks appear to me somewhat to ignore the evidence there brought forward: and at the same time I may remark that his statements as to the constitution of the yellow pigments appear to me hardly to invalidate, but rather indirectly to confirm, the suggestions made by me as to the reversion reaction with red pigments. The new information that Mr. Hopkins promises in his closing paragraph I shall look forward to with great interest.

April 22.

F. H. PERRY COSTE.

I WAS about to pen some remarks on Mr. Perry Coste's recent articles on this subject, when a letter from Mr. Gowland Hopkins in the last number of NATURE (p. 581) expressed substantially the same views as those which I had arrived at. I write now rather to support Mr. Hopkins in his strictures than to offer any fresh criticisms of my own. The articles on "Insect Colours" published in these columns are, as the author

states, to be regarded in the light of an abstract of a series of more extended papers published in the *Entomologist*. The papers in the latter publication from their title led us to suppose that Mr. Coste had made some contribution to our knowledge of the chemistry of insect pigments. I read them from month to month in the hope of getting new light on this subject, which is of such general interest to both chemists and biologists: I regret to say that I have been grievously disappointed. The experiments thus far described amount simply to the fact—not altogether astonishing—that strong chemical reagents modify the colours of Lepidopterous pigments or in some cases dissolve them out of the wings. The bearing of these observations on the chemistry of the pigments is so remote as to be practically useless until we know something of the chemical nature of these pigments. The methods adopted by Mr. Coste are not likely to advance our knowledge in this direction very much, and it is certainly remarkable that in treating of yellows he makes no reference<sup>1</sup> to the only real contribution to the chemistry of Lepidopterous pigments, viz. the experiments made by Mr. Hopkins, and published in the Proceedings of the Chemical Society in 1889. Mr. Coste is no doubt acquainted with those South American *Papilio*s with a large red spot on the hind wing, which spot loses its red colour and becomes of a brilliant metallic bluish green when the wing is tilted so that the incident and reflected rays form a very wide angle. The colour is in this case doubtless a mixed result, partly due to pigment and partly to interference. Now, anyone who has observed this and other similar colour phenomena in insects might describe his observations as contributions to the physics of insect colours. If he thought proper to adopt this course, he would be misleading physicists. The observation of the bare facts is as much a contribution to the physics of insect colours as the statement that a rainbow can be seen in the sky is a contribution to the physics of illuminated water-drops. It seems to me that Mr. Coste's experiments bear the same relationship to the chemistry of insect colours that the mere observation of interference colours in insects bears to the physics of insect colours.

Quite independent of the facts recorded by Mr. Coste is the interpretation which he puts upon them. Here I must decidedly express dissent. It cannot be admitted, because by the action of certain reagents green is changed into yellow or red into yellow, that this indicates the evolution of green or red from yellow. There is no evidence that this result is a reversion effect at all. The analogy between the action of strong acids in modifying the colour of an animal pigment and the effect of true reversion is forced, and has no parallel in natural processes. Hot water is a chemical reagent; by its action on the brown pigment of the lobster the latter becomes red. If from this observation I drew the inference that the ancestral lobster was red, and that the hot water produced a reversion effect, I do not think that Mr. Coste would agree with me.

Oxford, April 24.

R. MELDOLA.

#### Eozoon.

MR. GREGORY has, I fear, slightly mistaken the meaning of my remarks, which were intended rather to excuse than to blame him. The specimen of Eozoon collected by the late Mr. Vennor at Tudor was figured in connection with my paper of 1867 as a type specimen, in so far as macroscopical characters are concerned; but it does not follow that slices from specimens less perfect in that respect, and now in my collection, may not be more instructive as showing minute structures. I may refer in this connection to the three specimens from Tudor and Madoc (Madoc being in the same formation with Tudor) figured by Dr. Carpenter in our original paper in the *Journal of the Geological Society*, vol. xxiii., pl. xii., Fig. 1. If anyone will take the trouble to compare these with the figures in Mr. Gregory's paper in the same *Journal*, vol. xvii., he will have a singular and impressive illustration of the different ways in which things supposed to be the same may appear to observers of different types.

Mr. Gregory is in error in supposing that he could see in the cases of the Peter Redpath Museum my specimens from Tudor and Madoc. I have not yet been able to place there any portion of my microscopic cabinet of Eozoon; but only a few hand

<sup>1</sup> At least in *NATURE*: I have not the *Entomologist* at hand where I am writing.

specimens sufficient to show students the ordinary types of the fossil.

As to the Laurentian age attributed to the Tudor beds, I have already explained that this I subsequently regarded as an error, and so stated not long after the date of the paper of 1867. I now regard them as less ancient, though of pre-Cambrian age.

I shall be happy to show to anyone my little collection from Tudor and Madoc, including specimens in which Carpenter detected the canal system; but of these particular specimens I have unfortunately no duplicates for distribution, and would prefer to exhibit the slices in the modes I have found best suited for the development of the structures; as otherwise there might be some doubt whether the resulting impressions would more resemble Mr. Gregory's figures or Dr. Carpenter's.

Montreal, April 6.

J. WILLIAM DAWSON.

#### The Theory of Solutions.

I AM glad to see that as to the main point, the character of the "gaseous laws" of solutions, there seem to exist no more differences between Mr. Rodger and me. For Mr. Rodger, in his letter on p. 487 of *NATURE*, limits his remarks to some dialectical expressions, to cover an honourable retreat. I wish not to follow him on this way, because it is an endless one.

As to the application of van der Waals's formula on solutions, Mr. Rodger is now forced to confess that this application is not so "meaningless" as he has formerly written; but he asserts that, shortly spoken, the form of application given in my book is so. To say the truth, if I have to choose, as in this case, between the agreement of a formula with Mr. Rodger's opinion, and the agreement of this same formula with experiment, I prefer the latter.

Leipzig, April 12.

W. OSTWALD.

#### Physiological Action of Diminished Atmospheric Pressure.

WITH reference to the effect of diminished atmospheric pressure on the vital powers, alluded to in Prof. Bonney's review of Mr. Whympner's "Travels among the Great Andes of the Equator" (*NATURE*, April 14, p. 561), I do not know whether it is worth while recalling the well-known fact that numerous passes in the Himalayas, ranging from 17,000 to 19,000 feet, are habitually traversed by the hillmen, in the summer, with their flocks of sheep and goats carrying borax, &c. The highest pass is said to exceed 20,400 feet. In the same mountains Messrs. Schlagintweit reached an altitude of about 22,200 feet (*Proc. As. Soc. Bengal*, January 1866), while Mr. W. W. Graham ascended to 23,500 feet in 1883 (*NATURE*, September 11, 1884). I have myself, on several occasions, been to elevations of 17,000 to 19,000 feet, and beyond shortness of breath when climbing, never experienced any ill effects except once, when I, the four plainsmen with me, and three out of a considerable number of hillmen, felt severe headache during the evening after crossing a high pass. My companion on one trip, however, almost invariably suffered very severely from mountain sickness under similar circumstances.

F. R. MALLET.

18, The Common, Ealing.

#### Sensitive Water Jets.

A FORM of this effect lately presented itself, which seemed in some ways new. A thin jet, 5 feet high and arched so as to be 3 feet at the base, was falling in a feathery spray. At 13 feet distance a small Wimshurst machine was set going: not instantly, but after two minutes, the spray gathered itself up almost into one clear line: although the jet was turned up and down and the machine was discharged the falling water would not resolve itself again into spray for fifteen or twenty minutes. It is difficult to imagine the medium for this action: it is too indefinite, perhaps, to suppose that an indicator is found for the trembling of a disturbed ether while it is dying down.

The well-known experiment is not known enough, for it is not often described in books. Take a glass rod, electrified ever so little, to a certain point; at once the jet collects itself; a slight move away brings back the old disorder, while an inch nearer makes things much worse. It is a striking illustration to help one to imagine what the electrical forces of the air may do. We can perhaps understand those thick thundery rain-drops, that almost allow us to pass between them while they are giving friendly warning of what will come.

Winchester College, April 14.

W. B. CROFT.



## Double Orange.

THE abnormality in a Maltese orange described in NATURE of April 7 (p. 534) would appear of common occurrence in the Queensland or South Australian fruit. A friend assures me that in a case recently received from Australia, 80 per cent. of the contents showed small oranges, more or less perfect, either embedded in the pulp or in the rind. The quality of the fruit I observed was in no way affected. It would, however, be interesting to obtain further testimony. Although the small oranges may not affect the commercial value of the fruit, their presence would be undesirable in the groves where perfection is sought.

GERALD B. FRANCIS.

Katrine, Surbiton.

## ON THE LINE SPECTRA OF THE ELEMENTS.

THE distribution of the lines in the spectra of the elements is by no means so irregular as it might seem at first sight. Since Lecoq de Boisbaudran, in 1869, discovered the general plan in the spectra of the alkali metals, a number of interesting facts have been brought to light, which will probably one of these days find their mechanical explanation, and will then greatly advance our knowledge of the molecules.

Mechanical explanations of some of the facts have been attempted already. Lecoq de Boisbaudran explains the fact that the rays of the alkali metals are, on the whole, less refrangible the greater the atomic weight, by observing that the oscillations of a body suspended in a given elastic medium will become less frequent when the mass of the body is increased. This explanation, however, seems to me to remain rather vague and unsatisfactory as long as it does not lead to any numerical results that agree with the observations. Taken literally, it makes the oscillation-frequency inversely proportional to the square root of the atomic weight, which is far from being the case.

A second well-established fact has received different explanations by Julius<sup>1</sup> and by Johnstone Stoney.<sup>2</sup> It has long been observed by Hartley that in the spectrum of several elements a number of doublets or triplets of lines appear, the oscillation-frequencies in each doublet or triplet differing by the same amount. Recent measurements by Prof. Kayser and myself have confirmed this observation. Julius believes that this phenomenon is due to a cause analogous to the combination tones in the theory of sound.

If two rays, with oscillation-frequencies  $a, \beta$ , combine with other rays,  $p, q, r, s$ , to oscillation-frequencies

$$\begin{array}{ccccccc} p + a & q + a & r + a & & + a & & \\ p + \beta & q + \beta & r + \beta & & s + \beta & & \end{array}$$

the same difference  $a - \beta$  will occur several times. That the doublets under consideration are in many cases remarkably strong is accounted for by the fact that the intensity of the combination tone is proportional to the product of the intensities of the primary tones, so that it must become very strong when the amplitude of the primary tones is sufficiently increased.

Johnstone Stoney gives a different explanation of the doublets. He supposes that the path of the molecule from which light emanates is an ellipse, which by disturbing forces is gradually changed, and he shows that on this supposition, instead of one ray, two rays or more would originate, and the oscillation-frequencies of these rays would differ by an amount depending on the rate of change of the ellipse. If now, instead of the ellipse, the path of the molecule is any other curve, it can be considered as consisting of a number of superposed ellipses, all of which change in the same way on account of the disturbing forces. To each of the ellipses a doublet of lines corresponds, and the oscillation-frequencies of each

doublet differ by the same amount. In this explanation I do not understand the decomposition of the arbitrary curve in a series of superposed ellipses. For the movement is supposed not to be periodical, and Fourier's theorem then would not apply, at least the periods of the superposed ellipses would not be definite, as long as there are no data except the arbitrary curve itself.

Besides, both Johnstone Stoney and Julius only try to explain one of a number of regularities that have been observed in the spectra of the elements. A plausible suggestion about the movement of the molecules ought to explain more than one of the observed phenomena. I think it may be useful to point out the other regularities that have been observed in the distribution of lines, and for which as yet no mechanical explanation has been attempted.

(1) The doublets and triplets existing in the spectrum of an element can be arranged in series which show an appearance of great regularity. These series seem to be analogous to the over-tones of a vibrating body. But they possess a remarkable peculiarity, which, as far as I know, is without analogy in the theory of sound. The difference of two consecutive oscillation-frequencies decreases as these increase, and there seems to exist a finite limit to the oscillation-frequencies of a series. If  $n$  represents integer numbers, the oscillation-frequencies of a series may with great accuracy be represented by the formula—

$$A - Bn^{-2} - Cn^{-4},$$

where  $A, B, C$  are positive constants.  $B$  has nearly the same value for all the series of the different spectra.  $A$  is the limit towards which the oscillation-frequency tends, when  $n$  increases.

(2) For elements that are chemically related, the series are distinctly homologous, both in appearance of the lines and in the values of  $A, B, C$ , and with increasing atomic weight shift towards the less refrangible end of the spectrum. Homologous series have been observed in the following groups of elements:—

Lithium, sodium, potassium, rubidium, caesium ;  
Copper, silver ;  
Magnesium, calcium, strontium ;  
Zinc, cadmium, mercury ;  
Aluminium, indium, thallium.

In the first two and in the last group the series consist of doublets,<sup>1</sup> while in the remaining two groups they consist of triplets. Thus we may say that the spectrum shows a relationship between the elements similar to that between their chemical properties. It is interesting to note that magnesium forms a group with calcium and strontium, and appears more nearly related to them than to zinc, cadmium, and mercury.

(3) The doublets and triplets in each group broaden as the atomic weight increases. In the first group the difference of oscillation-frequencies is nearly proportional to the square of the atomic weight. The constant difference of the oscillation-frequencies in the doublets and triplets may also be noted in the values of  $A, B, C$ . For a series of doublets or triplets we have two or three different values of  $A$ , but only one value of  $B$  and one value of  $C$ .

(4) In each of the spectra of sodium, potassium, rubidium, and caesium, a series of doublets has been observed, in which the oscillation-frequencies do not differ by a constant amount, the difference diminishing inversely proportional to  $n^4$ . For these series  $A$  and  $B$  have only one value each. The least refrangible doublet of the series has the same difference of oscillation-frequencies as the doublets in the other series of the same element. In the spectrum of lithium there is a homologous series of single lines. All the lines of these series have the same

<sup>1</sup> Julius, *Annales de l'École Polytechnique de Delft*, tome v. (1839).<sup>2</sup> Stoney, *Trans. of the Roy. Dublin Soc.*, vol. iv. (1891).<sup>1</sup> Lithium has here to be excepted, whose lines are all single.

character; they are strong and easily reversed, and in all of them the first doublet is situated on the less refrangible side of the spectrum, and all the others in the violet and ultra-violet. The series shift towards the less refrangible side with increasing atomic weight.

For further details the reader is referred to the following memoirs:—Kaysner and Runge, "Ueber die Spectren der Elemente," *Abhandl. der Berl. Akademie*, 1890-92; Rydberg, "Recherches sur la constitution des spectres d'émission des éléments chimiques," *Kongl. Svenska Vetenskaps-Akademiens Handlingar*, Bandet 23, No. 11, 1890. C. RUNGE.

#### ABERRANT FOSSIL UNGULATES OF SOUTH AMERICA.

TILL within the last few years palæontologists and zoologists were being continually startled by the discovery of strange forms of extinct Ungulates which rewarded the researches conducted in the Tertiary rocks of the United States. The animals thus brought to the notice of the scientific world have, to a very large extent, modified our conceptions of the relationships of the various groups of hoofed or Ungulate Mammals to one another; and have led to the very general adoption of the view of the ordinal unity of all these multifarious types. Several of them, indeed, so far as we may judge from their mere skeletons, indicate signs of a transition between the Perissodactyle and Proboscidean modifications of Ungulate structure; but none of them tend in the least degree to break down the hard and fast line of demarcation between the Perissodactyle (odd-toed) and Artiodactyle (even-toed) modifications, which is maintained throughout all the known Tertiary deposits of the Old World. Moreover, after a little "shaking down," the whole of these North American Ungulates, with the exception of the curious Rodent-like *Tillotherium*, fall fairly well into their places in the Ungulate order; although some of the earlier and smaller types present indications of close affinity with the common stock from which we may presume both Ungulates and Carnivores to have taken origin.

At the present time the wave of discovery of new forms appears to be passing from the northern to the southern half of the New World; so that while the palæontologists of the United States are to a great extent engaged in the important task of revising and completing the preliminary work of the last twenty years, their *confrères* in Argentina are almost flooding scientific literature with descriptions—sometimes, it is to be feared, rather crude and hasty ones—of a number of new or hitherto imperfectly known forms of extinct mammals. This descriptive work has been mainly undertaken by Messrs. Ameghino, Burmeister, and Moreno. Unfortunately, however, the greater part of it is still in the form of preliminary notices, unaccompanied by illustrations; while on several points the three describers above mentioned are by no means in accord, and it is quite clear that unnecessary names have frequently been published. There is, indeed, one large illustrated work published by Dr. Ameghino; but since, so far as we are aware, there is only a single copy (in the Natural History Museum) in England, palæontologists have not the opportunity of paying it that attention in private study which its importance demands.

In spite, however, of these drawbacks, the information at present before us—imperfect though it be—introduces us to several groups of extinct Ungulates totally unlike any found in all the rest of the world put together, and which are of especial interest as tending to a certain extent to break down the distinction between Perissodactyles and Artiodactyles. It should be observed, before proceeding further, that the explorations conducted in

Patagonia and various parts of Argentina have shown that the deposits containing mammalian remains, instead of being exclusively of Pleistocene age, comprise a large portion of the Tertiary period, probably extending down at least as far as the Oligocene; although the exact correlation of the different beds with European deposits is probably premature.

With these preliminary observations, and asking our readers at the same time to bear in mind that a considerable part of our knowledge is still in a very imperfect and crude condition, we propose to glance at some of the peculiarities presented by the more remarkable forms of Ungulates described from the deposits in question.

Since the date of the publication of the results of Darwin's voyage in the *Beagle*, we have been gradually acquiring a knowledge of the structure of that remarkable South American Ungulate known as *Macrauchenia*, of which the complete osteology has been described by Burmeister. This animal, which had the general proportions and size of a horse, conforms in several respects—more especially in having three-toed feet, in which the middle (third) digit is symmetrical in itself—so markedly with the Perissodactyles, that by common consent it has been generally regarded as an extremely aberrant member of that group. The molar teeth are, indeed, more like those of the Rhinoceros and Palæotherium than of any other Old World Ungulates, while the infolding of the enamel of the crowns of the incisors is a character known elsewhere only in the horses. The absence of any gap in the dental series, and the nearly even height of the teeth, are characters in which *Macrauchenia* agrees with the Old World *Anoplotherium*. Perissodactyle affinities are indicated by the presence of a third trochanter on the femur; but in certain peculiarities in the ankle-joint this animal differs from all typical Perissodactyles, and agrees with the Artiodactyles. Moreover, a certain peculiarity of structure in the vertebræ of the neck is repeated elsewhere only in the camels and llamas, which form an isolated group of Artiodactyles. In the complete closure of the orbit by bone, *Macrauchenia* resembles the horses and many Artiodactyles; but in the narial aperture being situated on the top of the skull between the orbits (whence the nostrils were probably produced in the form of a proboscis), it is absolutely peculiar.

There are thus many indications that, while *Macrauchenia* is a specialized form that can in no sense be regarded as the ancestral type from which Perissodactyles and Artiodactyles have originated, it retains certain generalized features which were probably directly derived from such ancestral stock.

Among the Ungulates discovered in Patagonia is one named *Protherootherium*, which was at one time referred to the Artiodactyles, but subsequently placed among the Perissodactyles. In the skull, so far as can be gathered from Ameghino's description, the orbit is closed, as in *Macrauchenia*, but the narial aperture appears to have had the normal position. The molar teeth are so like those of true Perissodactyles that they were originally described under the name of *Anchitherium*; but the rest of the dentition is very peculiar. Thus, in the upper jaw there appears to have been only a single pair of incisors in the premaxillæ, these being pyramidal and obliquely truncated like the canines of the pigs; and as there were no canines, it may be inferred that there was a long toothless interval in the jaw. In the lower jaw there were two pairs of incisors, and no canines. The lower molar teeth were inserted by four distinct roots—a feature unknown in any existing Perissodactyle, although occurring in the pig. In the limbs, both the front and hind feet were furnished with three complete toes, much resembling those of *Hipparion*; the ankle-joint is, however, said to resemble that of the Artiodactyles. We have no information as to the third trochanter of the femur. On the whole, this genus appears to indicate a

Perissodactyle-like Ungulate, somewhat more specialized as regards its dentition than *Macrauchenia*, but exhibiting strongly-marked Artiodactyle affinities in the ankle-joint.

Still more remarkable are the generalized affinities displayed by the group known as the Toxodonts, of which the first representative was also discovered during Darwin's memorable voyage. These Ungulates cannot be included in either the Perissodactyla or Artiodactyla, and, therefore, come nearer the original generalized Ungulate stock than the animals already noticed. *Toxodon*, from the Pleistocene of Argentina, was of the approximate size of a Hippopotamus, and its osteology is tolerably well known. It takes its name from the curvature of the molar teeth, which approximate in structure to those of the Rhinoceros, and, like the incisors, have ever-growing roots. The front teeth are separated from the cheek-teeth by a considerable interval; the upper dental series being reduced in number by the loss of the outermost incisors and the canines, and the lower by the disappearance of the first premolars; the lower canine is, moreover, rudimentary. The feet conform to the Perissodactyle type in having three toes, of nearly equal size, and also in the interlocking of the bones of the upper and lower rows of the wrist- and ankle-joints. In the absence of a third trochanter to the femur, and also in the articulation of the fibula with the calcaneal bone of the ankle, as well as in the structure of the palatal and tympanic regions of the skull, *Toxodon* is, however, constructed on a decided Artiodactyle type; so that its characters are to a great extent intermediate between the existing members of the two groups.

Going back to the earlier Tertiaries of Argentina and Patagonia, a number of Ungulates allied to *Toxodon*, but with much more generalized characters, have been brought to light. The skulls from Patagonia brought back by Darwin, and named *Nesodon*, also belong to this same generalized group. In *Nesodon* there is the full complement of 44 teeth; and the same formula also obtains in the recently described *Protoxodon*, in which the feet are known to have been tridactylous in both limbs, although retaining rudiments of the metacarpals of the first and second digits, and being of a longer and more slender type than in *Toxodon*. The allied animals described as *Acrotherium*, some of which were about the size of a pig, present a peculiarity totally unknown among other Ungulates; and, indeed, in any Eutherian Mammals except some individuals of the small African long-eared fox (*Otocyon*). This peculiarity consists in the presence of eight cheek-teeth on either side of each jaw; the constancy of this character being proved by its occurrence in a considerable number of specimens. Whereas, however, in *Otocyon* the eight cheek-teeth are reckoned as four premolars and four true molars, in *Acrotherium* there are said to be five premolars and three true molars. If this interpretation be correct, it is difficult to point out a probable derivation for this most remarkable type of dentition, since no other heterodont mammals are definitely known to have more than four premolars.

If, however, the cheek-teeth really prove to be four premolars and four true molars, there might be a possibility of direct inheritance of the fourth molar of the Marsupials, although even then there is the difficulty that none of the Lower Eocene Ungulates of the United States are known to have possessed more than three of these teeth. And the probability accordingly suggests itself that the additional tooth may be an acquired redundancy. There are a number of other more or less closely allied types which have received distinct generic names, such as *Colpodon* and *Adinotherium*, but it is at present somewhat difficult to realize all their distinctive features and peculiarities. One genus, however, if the specimen on which it was established is normal, is so remarkable as to call for special notice; and taken

together with *Acrotherium* seems to show that these South American Ungulates ran riot in the disregard of all rules as to the number and arrangement of their teeth. The genus in question is *Trigodon*, founded upon the lower jaw of an animal about the size of a pig, but evidently related in the structure of its cheek-teeth to *Toxodon*. In this mandible the middle of the extremity of the long and narrow symphysis is occupied by a single cylindrical incisor tooth, flanked by a pair of larger incisors, and these, again, by the still larger triangular canines. If normal (and from Dr. Moreno's description and figure it would seem to be so) this single median incisor is totally unique in the whole mammalian class.

A still more remarkable and puzzling group is typically represented by the long-known *Typrotherium* from some of the Tertiaries of Argentina, which, while presenting many dental characters connecting it with the Toxodonts, has upper incisors resembling those of the Rodents; with most of which it also agrees in the presence of clavicles, which are invariably absent in all true Ungulates. The number of the teeth is similar to that obtaining in many Rodents, with the exception that there are two pairs of lower incisors. An allied type has, however, three pairs of these teeth, thus departing further from the Rodent type; and the skull of both genera is constructed on the Ungulate plan. All the teeth are rootless. From other beds in Argentina we have the genus described as *Hegetotherium*, which, while having rootless teeth, differs from *Typrotherium* in possessing the whole typical series of 44, without any marked interval between them. Here, then, we have almost entirely lost the Rodent features which are so marked in *Typrotherium*, and thus revert nearer to a normal Ungulate type; it is unknown whether clavicles were present. Still more generalized is an allied group typified by *Interatherium*, in which the dentition is always complete, the anterior premolars have distinct roots, and the incisors conical roots. This genus and the allied *Protyprotherium* thus appear to be connected both with *Typrotherium* and the Toxodonts; the specific name *rodens* applied to one of the species of *Protyprotherium* apparently indicating the existence of Rodent-like upper incisors.

The existence of these intermediate forms renders it exceedingly difficult to come to any satisfactory conclusion as to whether *Typrotherium* really has any genetic affinity with the Rodents (among which it was placed by the late Mr. Alston); for if there be such relationship it would seem to imply the descent of all Rodents from a form more or less closely allied to *Interatherium*—a view which can scarcely be maintained.

That these Typrotheroids were, however, in some manner connected with the Toxodonts is tolerably clear; and there are nearly equally clear indications of a more or less distant connection between the Toxodonts and the Macrauchenias. The most probable explanation of the latter relationship is that both groups took origin from generalized Ungulates allied to those found in the Eocene of the United States, and known as the Condylarthra, which appear to have been the common ancestral stock of both the Artiodactyle and Perissodactyle modifications of the order. On this view the retention of characters common to both the groups last-mentioned by the Toxodonts and Macrauchenias is readily accounted for; the Macrauchenias having acquired sufficiently well-marked Perissodactyle characters to admit of their inclusion in that group, while the Toxodonts cannot be placed in either of the two existing divisions of typical Ungulates. Having thus diverged at an early epoch (perhaps in the neighbourhood of Central America) from the original generalized Ungulate stock, the ancestral Toxodonts and Macrauchenias become the dominant forms in South America, where they appear to have developed into such numerous and unexpected modifications of struc-

ture, as to render the task of deciphering their mutual relationships and determining their exact systematic positions an exceedingly difficult, if not an impossible one. At the same time, however, it does not appear to us that the existence of these puzzling and aberrant types need interfere in the least degree with the commonly-accepted classification of the Ungulates, although there may be legitimate doubt as to the propriety of including the *Macrauchenias* among the Perissodactyles, instead of retaining them with the *Toxodonts* as a special group, exhibiting on the one hand many generalized features, coupled with extreme specialization in other respects.

R. L.

### THE CHANGEFULNESS OF TEMPERATURE AS AN ELEMENT OF CLIMATE.

ONE of the features in which the climates of great continents most contrast with those of oceanic islands, and those of higher latitudes with the climates of the tropics, is the greater range through which the temperature varies between night and day, and between winter and summer. Another, perhaps not less important, is the greater changefulness of the temperature from day to day. Both of these are comprised under the general expression *variability of temperature*,<sup>1</sup> and they are similar in their effects on living organisms, but they depend on very different causes, and in their local association are often manifested in very different degrees; places with a great annual and diurnal range of temperature, displaying great constancy of climate at any given season of the year, while others, at which the former variations are moderate in amount, are, nevertheless, subject to irregular vicissitudes of considerable magnitude. The Punjab and Sind may be cited as examples of the former class, Western and Central Europe of the latter.

Now, although from a sanitary point of view these two kinds of variation are of equal importance, the degrees in which they have respectively engaged the attention of climatologists and others are strikingly different. While the daily and annual range of temperature of all the more important and many minor places that have furnished meteorological registers are now well known, or are easily ascertainable from published records, the first systematic inquiry into the changefulness of temperature as an element of climate was that made by Prof. Hann in a memoir published in the *Sitzungsberichte* of the Vienna Academy of Sciences in 1875. In this paper, Dr. Hann tabulated the results of ninety stations, seven of which are situated in the southern hemisphere, and the remainder chiefly in Europe, Siberia, Canada, and the United States. The extraction of the data was not a little laborious, since it consisted in taking out from the daily registers, of generally from five to ten years, the differences of the mean temperatures of every pair of successive days throughout the whole period; then classifying them according to algebraic sign, as rises or falls of temperature, and also, in certain cases, according to their incremental values. The means of these different categories were then taken month by month, and the results are given in numerous tables in the memoir. The changefulness of temperature at any given place is the general mean of all changes during the period considered, irrespective of their being rise or fall. As instances of these, I take the following three stations, representing respectively the climates of Siberia, England, and Canada. They show

the average change of any two consecutive days on the Fahrenheit scale.

	Barnaul.	Oxford.	Toronto.
January ... ..	8.8	3.4	6.8
February ... ..	8.5	3.1	6.8
March ... ..	7.2	2.9	4.9
April ... ..	4.7	2.9	4.0
May ... ..	5.6	3.1	3.8
June ... ..	4.3	2.7	3.8
July ... ..	3.4	2.3	3.6
August ... ..	3.2	2.5	3.2
September... ..	4.5	2.5	4.5
October ... ..	5.6	3.4	4.1
November ... ..	9.0	3.6	4.5
December ... ..	10.1	3.8	6.7
Year ... ..	6.3	3.1	4.7

These three stations serve to illustrate the fact, amply confirmed by the general tables, that temperature is subject to greater and more rapid changes in the winter than in the summer; either December or January being, as a rule, the month of greatest variability.

Since the publication of this memoir, the inquiry thus started by Dr. Hann has been followed up by several writers with especial reference to particular countries. Prof. O. Döring, for instance, has thus discussed the statistics of the Argentine Republic; Herr E. Wahlén, those of 18 stations in Russia; Dr. V. Kremer, those of 57 stations in Northern Germany; and Mr. Robert Scott, those of 7 observatories in the British Isles, at which the temperature has been recorded by thermographs since 1869. These are Valentia, Armagh, Glasgow, Aberdeen, Falmouth, Stonyhurst, and Kew. At all these stations the variation was found to be less than at Oxford; but this may be partly due to the longer period (15 years) over which the records extend, and partly also to the fact that the daily means compared are those of the twenty-four hourly measurements of the thermograph curve, whereas the Oxford register was for 10 years only, and the observations less numerous. On the general average of the year, it was greatest at Kew ( $2^{\circ}7$ ), and least at Falmouth and Valencia ( $1^{\circ}9$ ).

Finally, Dr. Hann has resumed the subject in a memoir published in the *Transactions of the Vienna Academy*,<sup>1</sup> in which he discusses the temperature records of 66 stations in the Austrian Empire and the adjacent territories, of which one-half extend over from 10 to 20 years, and the majority of the remainder over at least five years; all, however, are corrected to the period 1871-80. In the case of Vienna, not less than 91 years have been included in the reckoning, and this register affords the means of comparing the results of any decade with those of a long period.

The first point that stands out in the results of this discussion is that even a period of ten years is insufficient to give more than an approximate value. The general mean change at Vienna, between any two consecutive days, is  $3^{\circ}4$  F., but in the decade 1861-70 it was only  $3^{\circ}26$ , whereas in the decades 1801-10 and 1871-80 it averaged  $3^{\circ}53$ . The means of the individual months show much greater variation; that of December especially, ranging between  $3^{\circ}2$  and  $4^{\circ}3$  in different decennia, or through 30 per cent. of the general mean for the month. It is evident that when computed from shorter periods than ten years the discrepancies will

<sup>1</sup> The term "variability" of temperature, adopted by Mr. Scott for the element now in question, has been already used in so many different senses, that in this paper I have adopted in preference the term "changefulness," which is not open to the same objection.

<sup>1</sup> "Die Veränderlichkeit der Temperatur in Oesterreich," von J. Hann, W.M.K. Akad., aus dem VIII. Bande der *Mat. Naturwiss. Classe der k. Akad. d. Wissenschaften*.

be still greater. In order, therefore, to obtain comparable values, even for neighbouring stations, it is essential that the data compared should be those of the same interval.

Both as regards season and amount, the changefulness of temperature depends very greatly on local geographical circumstances, so that neighbouring places very often differ greatly from each other. In Europe it increases from west to east and from south to north, in both cases towards the interior of the continent. It increases also on the whole with altitude, but very irregularly, being great on exposed plateaux, and comparatively small on mountain peaks. Places situated in valleys show very great differences, according to their exposure. Among the Austrian stations, those on the southern slopes of the Alps have the greatest vicissitudes, owing to the warmth they acquire in sunny weather and the consequent greater fall of temperature when a change of weather sets in. In general the changes of temperature at high elevations are greater than at low altitudes in summer, but less in the winter season. In the high mountain valleys in spring the changes are much smaller than on the neighbouring plains.

In the British Isles, Mr. Scott found that the number of rises exceeding  $5^{\circ}$  between any two consecutive days was greater than the number of falls of the same amount, and also that the mean value of the rises exceeds that of the falls. In Austria, also, except in the Southern Tyrol and on the coasts of the Adriatic, rapid rises are greater than rapid falls in the winter, and less in the summer; but on the whole the former preponderate. In the south, however, rapid falls are greater than rapid rises at all times of year, and therefore also on the mean of the year. This peculiarity is a still more marked characteristic of lower latitudes, since in Northern India it was found that rapid falls are about three times as numerous as rapid rises, and on the whole greater in amount.

The duration of rises of temperature is somewhat greater than that of falls, and both are rather greater at mountain stations than at low levels. Thus the passage of a wave of temperature, on the mean of the two stations Klagenfurt and Salzburg, occupies, on an average, 4.56 days, on the Sonnblick 4.93 days; or, in other words, 6½ days pass within the month at the higher and 7 at the lower stations. The longest period of continuous cooling that occurred at any station was ten days at the mountain observatory of Hoch Obir, and the longest continuous rise of temperature ten days at Klagenfurt. There is a marked annual periodicity in the length of the temperature waves, with two epochs of maximum, viz. in March and September, and two of minimum, in July and December. From the data afforded by certain stations in Austria and Saxony, Dr. Hann computes the following formula for their annual variation in Central Europe—

$$4.813 + 0.138 \sin(26^{\circ} 45' + x) + 0.164 \sin(318^{\circ} 27' + 2x).$$

The last subject investigated in Dr. Hann's memoir is the question whether the inter-diurnal changefulness of temperature shows any periodical variation during the sun-spot period; for which purpose he takes the 90 years' registers of Vienna, Wilna, and Warsaw. He finds that on the mean of these stations a certain minute variation is indeed apparent, but it is one of two maxima and two minima, and the whole range is so small that it is doubtful whether it is other than fortuitous.

In the foregoing paragraphs only a few of the more important results of Prof. Hann's investigation have been noticed. His memoir contains many others of interest, well worthy of study, and forming important contributions to general climatology; and like the original memoir, published seventeen years ago, it will doubtless stimulate others to prosecute the subject. It is especially import-

ant from a medical point of view that the statistics of all health resorts should be analyzed in the manner of which Prof. Hann has here given so admirable an example.

H. F. B.

### FORESTRY IN AMERICA.<sup>1</sup>

IT cannot be said that, as far as the issue of reports and pamphlets on forestry is concerned the Agricultural Department at Washington has been idle; if only this activity would resolve itself into the establishment of a State Forest Service, and the formation of State forests out of the wreck of the former forest wealth of North America!

An important series of papers on forest matters has come to hand, and though they date as far back as 1889, they are probably new to many of the readers of NATURE.

The first paper is by Dr. James, Professor of Public Finance and Administration in the University of Pennsylvania, and is entitled "The Government in its Relation to Forests." The Professor has evidently studied his subject thoroughly, and the remedy he proposes is the exact counterpart of that which has been so successfully applied to the forests of India. He commences by stating that the forests of any large country not only constitute a large portion of its wealth, but form the indispensable basis of a flourishing manufacturing and commercial industry. They are also one of the most important elements in determining the climatic conditions of a region, and, through these, the distribution of the population, of industrial pursuits, and of disease and health. He states that the value of the forest crop in the United States in 1880, the census year, was 700,000,000 dollars (= £140,000,000), and that if the value of the total annual output of the mines, quarries, and petroleum wells were added to the estimated value of all steamboats and other craft on American waters, it would still be less than the value of the forest crop, by a sum sufficient to purchase all the canals, telegraph companies, and construct and equip all the telephone lines in the States.

He then shows how Government has fostered agriculture by offering land on easy terms, by establishing model farms and agricultural schools, by improving the breed of stock, by free distribution of seed, and in many other ways; it has also assisted manufactures by the protective tariff, bounties, and exhibitions, &c.; and that vast sums have been spent by the State on improving rivers and harbours, and on the general means of communication—railroads and roads. Game and fish are also protected by the State, but although from their forests the Americans have been drawing more natural wealth than from all other sources together, yet practically nothing has been done to preserve them from the devastations of selfish people. Besides the great demands on the forests for timber, three-fifths of the people in the States use wood for ordinary domestic fuel, and the value of the wood fuel annually consumed is placed at 325,000,000 dollars.

Prof. James then treats at length of the vast indirect value of forests in maintaining a steady supply of water in rivers, and preventing floods. He shows that the maintenance of a system of factories and mills dependent on a watercourse becomes impossible when the stream is converted into a mountain torrent for one quarter of the year and is all but dry during another quarter; and instances the River Schuylkill, from which Philadelphia draws its water-supply, where the current has become too shallow and sluggish to carry off the ever-increasing

<sup>1</sup> "Department of Agriculture, Forestry Division. Bulletin No. 2.—Report on the Forest Condition of the Rocky Mountains, and other Papers." With a Map showing location of Forest Areas. Second Edition. (Washington: Government Press, 1889.)

quantity of impurities which pour into it, and consequently the quality of its water is steadily deteriorating.

The Professor considers it proved by European experience that a certain percentage of forest land is indispensable for any civilized country, and that when the forest area sinks below that percentage, through carelessness, or a selfish desire to get all the advantages from the resources of a country for the present generation, regardless of the interests of posterity, the result can only be an impaired industry and declining prosperity. He asserts that in the United States nothing is being done to cultivate forests, whilst vast areas, besides those which fall under the axe, are being wasted by fires and by unregulated grazing; so that, to put it mildly, the Americans are using up their forests at a much greater rate than they are replacing them, and are changing the character of their streams, soil, and local climate. Emphasis is laid on the fact that *tree-planting is not forest-culture*, and based on the experience taken from European countries, Mr. James insists that only the State can insure the preservation of the forests of America, and that private enterprise is powerless to prevent their eventual destruction.

His proposals to remedy matters are therefore that the Federal and State Governments should remove timber lands from the list of lands for sale, and after a thorough examination as to what forests are of climatic and industrial importance, should retain them under the control of Government. He also advocates the establishment of a School of Forestry, where men could be trained to manage the extensive tracts of forest lands in the ownership either of private individuals or of the State; and calls for further legislation, and active enforcement of existing laws to protect forests from fires and browsing animals. Here we have in a nutshell a proper forest policy sketched out for the United States; and it remains to be seen whether there is sufficient patriotism in the leading men to carry it out, or whether the great power of the timber trade, which has always insisted on non-interference with their business on the part of the State, will still obstruct the road to progress.

There is not space for much more than mere reference to the other papers contained in the Bulletin, the first being a most comprehensive report, by Colonel E. T. Ensign, on the forest conditions of the Rocky Mountains, showing the estimated area of forest still existing in each county of the States of Idaho, Montana, Wyoming, Colorado, and New Mexico, in 1887. A coloured map of the area shows the position and extent of the forest tracts. This report concludes with a most useful tabular statement, giving the area of forest in each county and for each State, as well as the character of the forest growth, the uses made of the timber, the principal causes of destruction of the forests, chiefly fires. Measures are suggested for the adequate protection of the forest growth, and any noticeable changes in the flow and volume of water in streams are noted. Under this head, we find that the streams have diminished in volume and their flow has become more intermittent in one-quarter of the ninety-one counties referred to, which altogether comprise an area of 555,081 square miles, still containing 83,460 square miles of forests in 1887.

The other papers are: "The Forest Flora of the Rocky Mountain Region," by G. B. Sudworth, and "On the Climate of Colorado and its Effects on Trees," by G. B. Parsons. The latter ascribes the barrenness of the eastern slopes of the Rocky Mountains to the extremes of temperature, and to the desiccating power of the north and north-west winds, which are frequently powerful enough to bark young trees by pelting them with gravel.

The Bulletin closes with a valuable paper on "Snow Slides and Avalanches," by B. E. Fernow, the present Chief of the Forestry Division of the Washington Agricultural Department.

W. R. FISHER.

#### NOTES.

THE following are the members of the Royal Commission appointed to investigate the question of a Teaching University for London:—Lord Cowper (Chairman), Lord Reay, Bishop Barry, Sir Lyon Playfair, Sir William Scovell Savory, Sir George Murray Humphry, Mr. George G. Ramsay, Rev. Canon Browne, Mr. Henry Sidgwick, Mr. John Scott Burdon Sanderson, Mr. James Anstie, Mr. Ralph Charlton Palmer, and Mr. Gerald Henry Rendall. No one who has devoted serious attention to the subject is likely to be of opinion that the choice of Commissioners is satisfactory. It shows that the Government has not grasped the problem.

THE International Congress of Chemical Nomenclature at Geneva has been attended by many representatives from various European countries. The representatives from England are Prof. H. E. Armstrong, F.R.S., Dr. J. H. Gladstone, F.R.S., and Prof. W. Ramsay, F.R.S.

PROF. A. CHAUVEAU has been elected to the presidency of the Société de Biologie, in place of Prof. Brown-Séquard, whose term has expired. The Société de Biologie was founded by Claude Bernard and a group of friends. Claude Bernard and Paul Bert were Presidents before M. Brown-Séquard.

A COMMITTEE has been formed to make preparations for the erection of a monument to Prof. de Quatrefages in his native village, Vallerange (Gard).

WE regret to have to announce the death of Prof. Annibale de Gasparis, Director of the Observatory at Naples, which took place on the 21st of this month. Born in Bugnara, in the province of Aquila, on November 9, 1819, he passed the first few years of his youth in Tocco Casuria, where he studied classics. Going thence to Naples in 1838 he began the study of mathematics under Prof. Tucci, dealing specially with the problems relating to bridges and rivers. Afterwards he devoted himself to astronomy, in which he soon gained great celebrity. In 1840 he was appointed assistant at the Capodimonte Observatory, where he became a diligent observer and an industrious calculator. His discovery of the three minor planets—Hygieia, Parthenope, and Egeria—created a great stir in the scientific world, and secured for him the Royal Astronomical Society's medal. Nominated as Director of the Observatory in 1864, owing to the death of Capocci, he worked incessantly for the advancement of practical astronomy, and followed up his observations for the capture of small planets. Eunomia, Psyche, Massilia, Themis, Ausonia, and Beatrix were all discovered owing to his ever careful scrutiny. His theoretical labours included many on pure mathematics, while those on astronomy related principally to the best methods of determining the orbits of comets. The investigations he carried on from time to time were numerous, and the results appeared in many periodicals, of which we may mention the *Atti della R. Accademia delle Scienze Fisiche e Matematiche di Napoli* and the *Astronomische Nachrichten*. De Gasparis was naturally robust, and enjoyed good health until he was attacked by the maladies which killed him. His powers of work were tremendous; he was always making either some calculation or observation. Being taken ill rather suddenly, he went away to recruit, but he became worse and worse, until at last he could not move. The sad days of the last year of his life he spent in reading the classics which he loved best, until his sight failed him.

MR. JOHN HARTNUP, the Astronomer to the Mersey Docks and Harbour Board, met with a fatal accident on the 21st while performing one of his Observatory duties. It seems that he was accustomed to examine occasionally the anemometers

situated on the flat roof of the building, the roof being skirted by a low wall about 20 inches in height. Being near the wall, and looking up at the anemometers, he was seized with a fit of giddiness, such as he had lately been accustomed to, and fell to the ground, breaking his neck. His sister-in-law, who saw the sad accident, had previously been cautioned by him not to go too near the wall when on the roof, for he considered it a dangerously low one. Mr. Hartnup was a member of the Royal Astronomical and Liverpool Astronomical Societies, and a Fellow of the Meteorological Society. He had succeeded his father in 1885, so that he was thoroughly familiar with the Observatory in which he had to work.

MISS AMELIA B. EDWARDS, whose death we have already recorded, has in her will endowed a Chair of Egyptology. Her library, which is very valuable, she has bequeathed to Somerville Hall, Oxford.

WE regret to hear that the venerable Prof. Svén Lovén has been compelled, as a result of the influenza, to retire from his position as Senior Keeper in the State Museum of Natural History, at Stockholm, where he has been active for fifty-one years. Prof. Lovén is now seeing through the press two important works on Echinoderm morphology, one dealing with the young stages of Echinoidea, the other with the Cystidea. We trust he may long be spared to enrich the world with these and other fruits of his wide knowledge and deep thought.

THE twelfth annual exhibition of natural history objects of the South London Natural History Society will be held on May 5 and 6 at the Bridge House Hotel, London Bridge, the whole of which building has been secured for the occasion. These exhibitions are growing in popularity, and several thousand visitors have each year taken lively interest in the exhibits. This year they will be exceptionally varied and novel. Lectures will be delivered by Mr. F. Enock on "The Life-history of the British Trapdoor Spider," by Mr. Step on "Edible and Poisonous Fungi," and by Mr. George Day on "Various Natural History Subjects."

AN Exhibition which will be interesting from a scientific as well as from a popular point of view will be held this year in the open ground near the Earl's Court railway station. It will illustrate the development of horticulture, and as Mr. H. E. Milner, F.L.S., is the chairman of the executive committee, we may expect that the scheme will be admirably carried out. There are to be examples of the gardens of all ages, including restorations of the ancient gardens of Egypt, Greece, and Rome; copies of those in China and Japan, and types of the Baronial, Italian, Tudor, Jacobean, Georgian, and Victorian eras. A large sub-tropical garden will be laid out, and there will be representations of the tea gardens of India and Ceylon. Various foreign countries—especially Belgium, Holland, France, Italy, and Germany—will co-operate to show the progress they have made in horticulture.

IN September a splendid Exhibition of fruit will be held in a temporary building, which is to be erected on a site on the Thames Embankment, near Blackfriars, lent for the purpose by the City Corporation. The Exhibition will be held under the auspices of the Fruiterers' and Gardeners' Companies, the Royal Horticultural Society, the British Fruit Growers' Association, and other kindred societies, and will last at least a week. In connection with the Exhibition lectures and object-lessons will be given on subjects relating to fruit culture and the planting of fruit trees.

THE Technical Instruction Committee of the Essex County Council appointed last year an organizing joint committee, consisting of six members of their own body, and six members of

the Essex Field Club. By means of the funds voted to this joint committee, peripatetic courses of lectures on various scientific and technical subjects have been carried on in different rural centres with considerable success during the past year. The principle on which the joint committee has carried on this work has been to employ only thoroughly qualified lecturers, and to insist upon the instruction being made as practical as possible. In some cases the lectures have been followed by practical work, in which the students have been taught how to use the microscope, and to dissect plants, as a means of acquiring a good working knowledge of vegetable physiology. This practical work has been so much appreciated in the rural centres that there has been an actual competition to gain admission to the class, the number of students being necessarily limited by the supply of apparatus and material. One of the most popular courses given under the auspices of the joint committee has been that on general science, a kind of elementary introductory course showing the advantage of acquiring scientific knowledge in its applications to daily life. There has been such a demand for this subject that four lecturers have been engaged to meet the wants of different parts of the county. Special courses on marketable fish and oyster culture will shortly be commenced for the benefit of the maritime centres. The organizing joint committee has, we are informed, not been reappointed by the new County Council, but that its labours have been appreciated is shown by the fact that the Council has decided to merge the joint committee in the main Technical Instruction Committee. The latter will thus secure directly the co-operation of the six representatives of the Essex Field Club, among whom are Sir Henry Roscoe, Prof. Meldola, and Mr. G. J. Symons. Essex is to be congratulated upon the wisdom which its Councillors have displayed in securing the services of such well-known scientific advisers.

A VERY beautiful aurora was visible from Westgate-on-Sea on Monday evening last. When it was first observed, about 9.30 p.m., the sky was brilliantly illuminated to a height of about 30° above the horizon, extending laterally quite 50°. It seemed to be decidedly of a pinkish colour, but to all appearance this tint gradually disappeared. About ten minutes later, two fine streamers were thrown out, their approximate positions on the celestial sphere corresponding to the lines joining the stars  $\alpha^2$  Cygni,  $\epsilon$  Draconis, and  $\alpha$  Lacertæ,  $\pi$  Cephei. Their light was considerably more intense than the aurora itself, the beams reminding one rather of those produced by a strong search light. East and west of these, two more beautiful bright streaks were shot out, extending to a height not quite so great as the former two. The west one became especially fine, its light exceeding that of any of the others. Their positions, as near as could be gathered, lay between the stars  $\rho$  Cygni and  $\sigma$  Draconis for the west one, and for the east one  $\sigma$  Andromedæ and  $\tau$  Cassiopeie. Five minutes later these vanished, and the two central ones merged into one and also disappeared. At 12.30, only one streamer was visible, while its light and that of the aurora itself was of a very feeble nature.

THE weather during the past week has become on the whole much more seasonable all over the country. Westerly winds have prevailed during the greater part of the period, and the air has been mild and genial; but the temperature, although high for the season, was lower than at the commencement of the month. Rain has fallen very generally within the last few days in all parts of the kingdom, and thunder, lightning, and hail have occurred in many places. A brilliant aurora, to which reference is made in the preceding note and in several letters, was observed in Scotland and in several parts of England during Monday night. The weather report of the Meteorological Office for the week ending April 23, showed that bright

sunshine, although less than in preceding weeks, still exceeded the mean value in nearly all districts.

LAST week California was visited by the most severe earthquake which has been known in that region since 1868. On April 19 shocks were felt over a distance of 200 miles, the intensity varying at different points. In San Francisco a number of large buildings trembled perceptibly, but only one was damaged—an old church building until lately occupied by the Academy of Science. The front wall gave way, tearing away the balconies. The centre of the disturbance was Vacaville, where a number of brick buildings both in the town and in the vicinity were destroyed or damaged. Many walls also fell into the streets. At Winters and Dixon serious damage was done to buildings. On April 21 further shocks occurred at San Francisco, and were felt in the surrounding districts. A number of buildings were demolished at Winters, and several persons received injuries. Eight distinct vibrations were felt. At Biggs clocks stopped, and plaster fell from the ceilings of the houses. At Woodville several brick buildings were damaged, while at Vacaville some walls which had been cracked by the previous shocks were demolished, and the ceilings in most of the houses were cracked. At Sacramento also some damage was caused, but the place which seems to have suffered most severely was Dixon, where extensive damage had already been caused by the shocks of April 19.

DR. A. C. OUDEMANS, Director of the Zoological Gardens at the Hague, has for some years made the sea-serpent a subject of special study, and now he is about to issue a book in which he will present his conclusions. He states in a prospectus that he was attracted to the question by "an account of the appearance of a sea-serpent published in NATURE of November 8, 1880." As NATURE was not published on November 8, 1880, a good many people may be tempted to think that this reference (due, of course, to a slip of the pen or to a misprint) is very suitable to the nature of the animal to which it relates. Dr. Oudemans has placed side by side "all the accounts, tales, and reports of this great unknown animal," and has convinced himself that "through all the reports there runs only *one* red thread, that there must be *one* single animal species which has given rise to *all* the reports." The author has chosen to write in English, because it is a language "known to all navigators, as well as to all zoologists, and other men of education." The full title of the work will be "The Great Sea-Serpent. An Historical and Critical Treatise. With the Reports of 166 Appearances, the Suppositions and Suggestions of Scientific and non-Scientific Persons, and the Author's Conclusions." There will be 82 illustrations.

WE are glad to hear that Mr. J. J. Wild, Ph.D., who accompanied the *Challenger* as secretary to the Director (Sir Wyville Thomson) and artist to the Expedition, is settled in Melbourne, Victoria, where he is engaged in producing plates illustrative of the zoology and palæontology of the colony, under the direction of Sir Frederick MacCoy, F.R.S. He is at present figuring the fossil remains of Acanthodian fishes discovered in the Old Red Sandstone of Mansfield, Victoria.

THE programme of the first series of summer excursions of the Manchester Field Naturalists' Society has just been issued. Mr. Leo Grindon, the founder of the Society thirty-two years since, has been compelled, by advancing years and impaired health, to resign the presidential chair, which Mr. Chas. Bailey has undertaken to occupy. Mr. Grindon retains the office of botanical referee, with the assistance of Mr. W. Gee, who is engaged in teaching natural history subjects under the Science and Art Department. A special study, appropriate to the season and locality, is appointed for each meeting; and

a field card, directing observation in each of the seven sections of the Society, is in preparation. A course of lessons, treating in detail of the leading natural families of the Manchester Flora, is being given in the city.

At the meeting of the Royal Statistical Society on Tuesday, Mr. R. Henry Rew read a valuable paper on the statistics of the production and consumption of milk and milk products in Great Britain. The subject, as he pointed out, is one of extreme complexity. The effective production of milk by a single cow ranges from *nil* (in the case of a cow which only rears her calf) to 1200 gallons or more. The number of cows and heifers returned in 1890, the year taken as a basis for calculation, was 3,956,220, of which it is reckoned that 3,544,575 are productive. Returns now collected from a large number of districts, together with other data, justified an estimate of 400 gallons per cow, making the total quantity of milk available for consumption in various forms in the United Kingdom 1417 million gallons. The number of cows has decreased in proportion to population. In Great Britain there were in the period 1866-70 82·1 cows per 1000 of population, while in 1886-90 there were only 77·9. The absolute number of cows had increased, but not sufficiently to keep pace with the growth of population. The latest return (for 1891) is more encouraging, showing as it does the largest number of cows on record. In Ireland the period 1886-90 showed a higher proportion (290·8) of cows to population than in any of the four preceding quinquennial periods, but this was due not to an increase in the number of cattle, but to the decrease of population. The 1417 million gallons of milk produced in the United Kingdom is thus accounted for:—Consumed as milk 570 million gallons; butter, 617 million gallons (representing 105,000 tons of butter); cheese, 224 million gallons (representing 100,000 tons of cheese); miscellaneous (condensed milk, &c.), 6 million gallons. Mr. Rew admitted that the results arrived at were only tentative. He expressed a hope that before long some official help might be given in the solution of a problem which was of the deepest interest to statisticians, agriculturists, and social economists.

THE Bath and West of England Society decided some time ago to appoint a research chemist to make investigations upon the making of cheddar cheese. Mr. Fred. Jas. Lloyd was chosen to fill this post, and he has recently presented his report of the work done in August, September, and October of last year. The results obtained, though by no means complete, are both valuable and interesting, and it is to be hoped that the Society will continue and extend the work. The experiments were made at the Society's Dairy School, near Frome, and it was found possible to make a cheese in such a way as to be guided in judging the condition of the curd by determinations of acidity alone. The product was a decided success in every respect. The average acidity of the mixed milk before adding rennet was '24 per cent., but on setting the whey only showed '16 per cent. of lactic acid. It was proved, by continued experiment, that when the whey showed a percentage of acidity slightly greater than that in the milk before renneting the process was sufficiently advanced to draw off the whey and pile the curd. Determinations of acidity in the later stages of manufacture have yielded similar results, and it appears to be certain that the careful development of definite amounts of lactic acid at definite steps in the process is essential to success. The bacteriological observations show that, although very many organisms are liable to get into the milk, the majority of them are not able to exist in an acid material, consequently by insuring a proper development of acidity in the curd we destroy their activity, which would otherwise spoil the cheese. Not only does the *Bacillus acidi lactici* play the most important part in the making of the cheese, but it is also the chief agent in the ripening process.



It is well known that serious loss is caused in the various Australian colonies by the ravages of the rust fungus in wheat. An Intercolonial Conference met to consider the subject in 1890, and this body has since held two other meetings, the third having taken place at Melbourne last month. Many experiments have been made, and it has been clearly shown that there are several varieties of wheat which, except under very unusual circumstances, are never seriously attacked by rust. It has also been shown that in many districts early sown wheats of a rust-labile kind generally escape damage by rust, when the same wheats sown late suffer seriously. In view of these facts the Conference has directed attention mainly to encouraging the growth of varieties less liable to be attacked by rust, and also to early sowing. At the March meeting it was recommended that a practical system for the production and distribution of rust-resisting wheats suitable to different districts should be immediately established, and that this system should, subject to modifications needed by each colony, be conducted on the following lines:—A central station for each colony for the preliminary testing of new wheats introduced into the colony; for the production of new varieties by cross-fertilization and by selection; and for the distribution of suitable wheats thus obtained to representative districts of the colony, to be there subjected to a sufficient test, and, if necessary, fixed in their characters by farmers and others competent for the work; and that such wheats as pass satisfactorily this test should then be distributed to the farmers around in such a manner and by such agency as would be most suitable to the conditions of each colony. A committee was appointed to take steps for the proper naming of the different varieties of wheat.

THE U.S. Department of Agriculture has received information to the effect that *Vedalia cardinalis* has been successfully colonized at the Cape of Good Hope. Last autumn Mr. Thomas A. J. Louw, a special commissioner from the Legislative Assembly of the Cape, went to Washington charged with the task of collecting and taking back from America a supply of the useful little lady-bird mentioned. He was furnished with letters to the California agents of the Department, and took away from that State two parcels of *Vedalia*, one lot being shipped on ice and the other kept open and fed *en route*. Both were alive when he arrived at the Cape, and he writes that the experiment has been so successful that various parts of the colony have been supplied with the insect, which, no doubt, will be as useful in clearing off the Cottony Cushion Scale there as it has been in California and the Hawaiian Islands. Mr. Louw's letter, dated Malmesbury, Cape of Good Hope, March 5, 1892, to the Hon. Edwin Willits, Assistant Secretary of Agriculture, says: "While thanking you again for the kindness displayed towards me, may I request you also to convey to Prof. C. V. Riley my extreme obligations for the service rendered by him to me, and which I assure him will ever be appreciated by me."

DR. HYADES, as we noted last week, was impressed, while in Tierra del Fuego, with the resemblance between the Yahgan and the Botocudos of Brazil. Of the latter people an interesting account appeared lately in the Washington *Evening Star*, and is reproduced in the April number of *Goldthwaite's Geographical Magazine*. The colour of the Botocudos is described as of a light yellowish-brown. When brought into contact with Europeans they manifest not the slightest embarrassment on account of their lack of clothing. From certain seeds and fruits they obtain brilliant dyes, with which they adorn their bodies; and a common custom is to paint the face above the mouth a bright red, the upper half of the body being stained black, and a red stripe encircling the waist. A warrior thus decorated, with lip and ear ornaments, is said to present "a most demoniacal

expression." The colours employed are mixed in the upper shell of a turtle, and carried in joints of the bamboo. The arms of the Botocudos consist of the bow and arrow. For calling one another in the forest they have speaking trumpets made of the skin of the tail of the great armadillo. While travelling through the woods, they build for themselves temporary shelters of palm-leaves, sticking the stems into the ground in a half-circle, so that the tips of the fronds arch together and form a sort of roof. When encamping for a considerable time in one place, they construct houses often big enough to hold several families. The fire is placed in the middle of the dwelling, and the beds are made of bark fibre. Gourds are used for drinking purposes and in the preparation of food. The Botocudos have been harshly dealt with by the Portuguese, and are rapidly dying out.

CAPTAIN BOWER, of the Indian Staff Corps, has arrived at Simla from China, after a very remarkable journey across the Tibet tableland. He had with him Dr. Thorold, a sub-surveyor, one Pathan orderly, a Hindustani cook, six caravan drivers, and forty-seven ponies and mules. The Calcutta correspondent of the *Times*, who gives an account of the journey, says that Captain Bower, leaving Leh on June 14, crossed the Lanakma Pass on July 3, avoiding the Tibetan outpost placed further south. Journeying due east, he passed a chain of salt lakes, one of which, called Hor-Ba-Too, is probably the highest lake in the world, being 17,930 feet above the sea. Gradually working to the south-east, the explorer saw to the north a magnificent snowy range, with a lofty peak in longitude 83° and latitude 35°. After many weeks' travel over uplands exceeding 15,000 feet in height, where water was scarce and no inhabitants were to be seen, the party on September 3 reached Gyak-Kin-Linchin, on the northern shore of Tengri Nor Lake, in longitude 91° and latitude 31°. This is within a few marches of Lhasa, and two officials from the Devi Jong, or temporal governor of Lhasa, met him here and peremptorily ordered him to go back. But he refused to return, and a compromise was effected, guides and ponies being provided on his agreeing to make a detour to the north in order to reach the frontier of Western China. He reached Chiampo on December 31, only just succeeding in getting off the tableland before winter set in. He struck Bonvalot's route for a few miles when marching to Chiampo. The country about this town is very fertile and well wooded. Three thousand of the monks of Chiampo, who lived in fine monasteries, threatened to attack the party, but were deterred on learning that they carried breechloaders. Captain Bower arrived at Tarchindo, an outpost on the Chinese frontier, on February 10. The distance covered from Lanakma to Tarchindo was over 2000 miles, all of which, save a few miles, has now been explored for the first time. The route for thirteen consecutive days lay over a tableland 17,000 feet high. Captain Bower is engaged in writing a report and completing his maps.

SPLENDID specimens of mica are to be sent to the Chicago Exhibition from Idaho, where the supply is said to be practically inexhaustible. Mica is to be used in the Idaho building as a substitute for glass in the windows. The *Photographic News* suggests that, if the reports as to the quality of the material prove to be accurate, it may become a rival to glass in photographic plate-making.

AT the meeting of the Paris Geographical Society on April 1, Lieutenant Vedel read an interesting paper on the Polynesians, whom he has had constant opportunities of studying during the last seven years. Referring to the Maoris, he said it was impossible not to be struck with the extraordinary resemblance which exists between their myths and those of the ancient Greeks.

THE Southport Society of Natural Science has issued its first report, from which we learn that the Society, although still very young, is doing good work as a local centre of scientific inquiry. The report includes a presidential address by Dr. H. H. Vernon, on the material and educational utility of natural science.

MR. EDWARD STANFORD has issued "The Hand-book of Jamaica for 1892." This is the twelfth year of publication. The work has been compiled from official and other trustworthy sources by S. P. Musson and T. Laurence Roxburgh. It comprises all necessary historical, statistical, and general information relating to the island.

THE latest instalment of the Transactions of the Royal Society of Victoria (vol. ii. part 2) opens with a paper on the occurrence of the genus *Belonostomus* in the rolling downs formation (Cretaceous) of Central Queensland, by R. Etheridge, Jun., and A. S. Woodward. There are also papers on the structure of *Ceratella fusca* (Gray), by Prof. W. Baldwin Spencer; additional observations on the Victorian land planarians, by Dr. A. Dendy; and land planarians from Lord Howe Island, by Prof. W. Baldwin Spencer. Each of the papers is illustrated.

PROF. S. H. GAGE, of the Cornell University, has reprinted an interesting paper contributed by him to the *American Naturalist* on the life-history of the vermilion-spotted newt (*Diemyctylus viridescens*, Raf.). He has added to it a valuable annotated bibliography.

A REPORT on the geology and mineral resources of the central mineral region of Texas, by T. B. Comstock, was included in the second Annual Report of the Geological Survey of that State, and has now been issued separately. It ought to be of good service to practical men as well as to students of science. The author has a valuable note in which he shows how the prospector, the capitalist, or the property-holder may most advantageously use the report.

AN excellent essay on aboriginal skin-dressing, by Otis T. Mason, has been reprinted from the Report of the U.S. National Museum for 1888-89. It is based on material collected in the Museum, and includes an account of skin-dressing among the Eskimo and the Indians. There are many illustrations.

THE following science lectures will be given at the Royal Victoria Hall during May:—May 3, "Flying Bullets," by C. Vernon Boys; May 10, "Travels in Java and Sumatra," by Wm. Hancock; May 17, "The Wonders of the Rocky Mountains," by Wm. Carruthers; May 24, "Mines and Mining," by Bennett H. Brough; May 31, "The Alps in Winter," by C. T. Dent.

THE results of an investigation, concerning the conditions of silent combination of the hydrogen and oxygen contained in the detonating mixture of these gases obtained by the electrolysis of water, are communicated to the current number of *Liebig's Annalen* by Prof. Victor Meyer and Herr Askenasy. The object of the experiments was to ascertain whether any regular connection existed between the duration of time, during which such a mixture of the two gases is maintained at a temperature at which silent combination slowly proceeds, and the amount of water produced. The main result of the experiments has been to afford a direct negative to this question, the amount of combination under precisely the same conditions of temperature, pressure, and time varying most irregularly. Although this is the case, however, some interesting phenomena have been observed during the course of the experiments. It was found that, when a quantity of the pure dry mixture of two volumes of hydrogen and one volume of oxygen was sealed up in a glass

bulb and heated in a bath of the vapour of phosphorus pentasulphide, the temperature of which (518°) is such that the bulb becomes faintly luminous, no explosion occurred, but a small proportion of the gases silently combined, with production of water. Upon immersing the bulb, however, in a bath of boiling stannous chloride (606°), explosive combination instantly occurred. It was surmised, therefore, that the temperature at which explosion occurs lies somewhere between 518° and 606°. But upon modifying the experiment in such a manner that the bulb was open, a slow stream of the gaseous mixture being allowed to pass continuously through, it was found that no explosion ensued under these conditions at the temperature of boiling stannous chloride, although at this temperature the bulb glows with a cherry red heat, and the glass is quite soft. It appears likely, therefore, that the extra pressure of the gases in the closed vessel determines the explosion at a lower temperature. The irregularity in the rate of silent combination would appear to be due to the different condition of the inner surfaces of the vessels containing the gaseous mixture; probably largely owing to the different amount of etching action by the water vapour at these high temperatures. In order to eliminate this disturbing element, the experiments have been repeated with bulbs whose inner surfaces have been equally etched beforehand and with bulbs whose interior walls have been silvered, the results, however, showing in both cases the same irregularity. In connection, however, with the experiments with silvered bulbs, another striking fact has been brought to light. It was found that in these bulbs the silent formation of water occurs at temperatures several hundred degrees lower than in unsilvered glass bulbs. Complete combination had occurred in two hours' time at the temperatures of boiling phosphorus pentasulphide (518°), sulphur (448°), diphenylamine (310°), and naphthalene (218°); 70 per cent. of the mixed gases had combined at the temperature of boiling aniline (183°), and a small amount of combination had occurred even at 155°. Finally, it was found that bright July sunshine is incapable of inducing the combination of hydrogen and oxygen, even when it is concentrated upon a bulb traversed by the gaseous mixture and heated to 606° in a bath of boiling stannous chloride.

THE additions to the Zoological Society's Gardens during the past week include a Patas Monkey (*Cercopithecus patas*) from West Africa, presented by Mr. W. S. Hewby; two Orinoco Geese (*Chenalopex jubata*) from South America, presented by Mr. Everard F. Im Thurn, C.M.Z.S.; two Mute Swans (*Cygnus olor*), European, presented by Mrs. Melville; a Herring Gull (*Larus argentatus*), British, presented by Miss Lota Bower; two Chinese White-eyes (*Zosterops simplex*) from China; an Egyptian Goose (*Chenalopex aegyptiaca*) from Africa, deposited; a Cheer Pheasant (*Phasianus wallichii* ♂) from Northern India, a Swinho's Pheasant (*Euplocamus swinhoii* ♀) from Formosa, a Common Pheasant (*Phasianus colchicus* ♀), British, six Wigeon (*Mareca penelope*, females), twelve Common Teal (*Querquedula crecca* 6 ♂ 6 ♀), European, purchased; a Crested Porcupine (*Hystrix cristata*), born in the Gardens.

#### OUR ASTRONOMICAL COLUMN.

SPECTRUM OF NOVA AURIGÆ.—On February 22, Mr. E. W. Maunder obtained a photograph of the spectrum of Nova Aurigæ with an exposure of seventy minutes. The photographic magnitude of the star was then 4.78, and its visual magnitude was about 5.7. Bright lines were observed upon the plate at the following wave-lengths:—4919, 4860 (F), 4629, 4560, 4547, 4510, 4472, 4340 (G), 4229, 4174, 4101 (H), 3988 (H), 3933 (K), 3887.5 (α), 3834 (β). And dark lines had their positions located as follows:—4316 (G), 4212, 4155, 4085 (H), 3953 (H), 3913 (K). Measures of the displacement

of the dark lines relatively to the corresponding bright ones gave a mean of 18.3 tenth-metres. According to this, the relative motion of the two bodies engaged was about 820 miles a second. Mr. Maunder also observed the visual spectrum of the Nova. Three bright lines were seen, and estimated to be in the positions of C, D, and F of the solar spectrum. A line was detected "not far from E," another "near *b*, but further towards the blue," and another "very near the chief nebular line." The line measured on the photograph as at  $\lambda$  4919 was also made out.

**PHOTOGRAPHS OF THE REGION OF NOVA CYGNI.**—At the March meeting of the Royal Astronomical Society, Mr. Roberts stated the results of a comparison of Drs. Copeland and Lohse's catalogue and chart of the region of Nova Cygni with two photographs of the same part of the heavens taken in September 1891. It appears that the brightness of some of the stars has undergone changes since 1878, when the chart was made. Changes of this character may, of course, be due to the well-known difference between visual and photographic magnitudes; but there are other differences, which are not so easily explained. Several stars, single on the chart, are seen to be double on the photographs, and some changes in relative position seem to have occurred. Although the Nova is not given on the chart, it appears on the photographs as a star of about magnitude 13. It will be interesting to compare Mr. Roberts's pictures with others taken under similar conditions at some future date, in order to determine definitely whether the changes are real, or due to errors in observation or cataloguing.

**WINNECKE'S COMET.**—Dr. G. F. Haerdtl gives the following ephemeris in *Astronomische Nachrichten*, No. 3083:—

1892.	R.A.	Decl.	Brightness.
	h. m. s.	° ' "	
April 29 ...	11 36 4.49	+43 55 41.3	
" 30 ...	34 22.64	44 2 13.6	
May 1 ...	32 42.41	8 8.3	2.38
" 2 ...	31 3.89	13 25.6	
" 3 ...	29 27.21	18 6.3	
" 4 ...	27 52.46	22 11.9	
" 5 ...	26 19.62	25 43.4	2.71
" 6 ...	24 48.66	28 42.1	
" 7 ...	23 10.55	31 8.6	
" 8 ...	21 52.27	33 3.6	
" 9 ...	20 26.81	34 28.1	3.10
" 10 ...	19 3.16	35 23.3	
" 11 ...	17 41.31	35 50.0	
" 12 ...	16 21.18	35 49.6	
" 13 ...	15 2.62	35 22.5	3.58
" 14 ...	13 45.50	34 29.4	
" 15 ...	12 29.98	33 11.2	
" 16 ...	11 15.72	31 28.7	
" 17 ...	10 2.63	29 22.9	4.17
" 18 ...	8 50.51	26 55.0	
" 19 ...	7 39.29	24 5.2	
" 20 ...	6 28.92	20 53.7	
" 21 ...	5 10.08	17 21.4	4.91
" 22 ...	4 9.48	13 29.0	
" 23 ...	2 59.99	9 17.4	
" 24 ...	1 50.50	4 47.8	
" 25 ...	11 0 40.59	44 0 0.3	5.84
" 26 ...	10 59 29.91	43 54 55.3	
" 27 ...	58 18.15	49 33.4	
" 28 ...	57 5.05	43 55.1	
" 29 ...	55 50.13	38 0.7	7.04
" 30 ...	54 33.03	31 50.9	
" 31 ...	53 13.21	25 25.2	

**PERSONAL EQUATIONS IN TRANSIT OBSERVATIONS.**—An accurate determination of an observer's personal equation is to-day of as much importance as an observation itself, when such small quantities, as we now deal with, have to be measured. The variation in the latitude, of which we have heard so much of late, amounts to a quantity only a few times larger than that of a moderate personal equation, showing that no small regard must be paid to its estimation. In observing an N. P. D., the star has to be bisected by the horizontal wire, while the nadir point has also to be observed: in both these cases an error can arise from personality, for the best observers cannot make a really true bisection. In the taking of transits another personality exists, but this is rather of a different kind, for, using the eye

and ear method, the clock beats have to be taken into account simultaneously with the relative positions of the star and certain wires. In the April number of the *Bulletin Astronomique*, an account is given of some experimental researches on such transit determinations in which both methods, the eye and ear and the chronograph, were used. The observations were made with an apparatus similar to that designed by Wolf, who, to obtain artificial transits, employed a small truck to carry the plates, on which punctures of different sizes were made. From 115 observations made with both methods, it was found that equally accurate results were obtained, the eye and ear method, if any, proving a little inferior, while the degree of lighting of the field made no appreciable variation on the personal equation. For planets the electrical method showed that personality varied considerably, according to whether the preceding or following side was observed: the resulting personal equation for the centre of a planet turned out to be  $-0.046s$ , while that for a star under the same conditions was  $+0.023s$ . It would be interesting to find out whether this occurs when the eye and ear method is employed. The tendency of an observer, adopting the eye and ear method, to choose certain tenths of a second in preference to others, seems to have its analogy in the chronograph method, in the linear measurement from the second impressions. A comparison given here shows that the most favourable tenth is the zero, while the nine is very considerably left out in the cold. Another very curious fact is that the tenths, one, two, three, four, chosen in the chronograph methods, are all less than the corresponding ones in the other methods, while the opposite occurs for the tenths five to nine.

Tenths	0	1	2	3	4	5	6	7	8	9	Total
Eye and Ear . .	157	97	134	134	100	94	82	81	74	57	1000
Chronograph . .	164	79	96	90	94	129	104	94	81	69	1000

**THE SIRIUS SYSTEM.**—Dr. A. Auwers contributes to the *Astronomische Nachrichten*, Nos. 3084 and 3085, a long discussion with reference to our "Knowledge of the Sirius System." The problem which he undertook was to investigate whether the measures of the companion obtained during the period extending from 1862 to 1890 would satisfy an ellipse with a 49.4 year revolution; to determine the most probable value of the place elements for every measurement on the assumption of the revolution; and to inquire whether the observations of the principal star could be represented by means of the so determined elements. The author divides the discussion into the following three parts:—(1) A summation and sifting of all the measures that have been made of this companion for the above-mentioned period. (2) The derivation of the normal places, and the correction of the elements. (3) A comparison of the meridian observations of Sirius with the elements derived from the measurements of the companion. The result of the discussion is that a slight correction is necessary to reduce the right ascension and declination of the bright star to the centre of gravity of the two bodies (the masses of the chief star and of the companion being taken as  $2.20\odot$  and  $1.04\odot$ ). The table showing these corrections indicates that the right ascension between the years 1850 and 1890 has to be increased by a quantity which reaches to  $0.232s$ , while between 1890 and 1896.5 a diminution takes place. The greatest correction for the declination is  $+2.268s$ , which occurs in 1882.0, and this correction becomes negative also about 1893.5.

THE ANCIENT CIVILIZATION OF CENTRAL AMERICA.

**I**N Central America there are abundant traces of the existence of a great race which must at one time have attained to a comparatively high state of culture. It was undoubtedly a race of American Indians, and as undoubtedly closely connected with the present Indian inhabitants of the country.

No trace, however, of the ancient culture and knowledge can be found amongst the Indians of to-day, and the numerous ruins which lie scattered over the country are the remains of towns which have neither names nor history attached to them.

Very little information can be gathered from the published writings of the Spaniards who overran the country at the close of the fifteenth and beginning of the sixteenth centuries; but, apart from their bearings on Spanish history and biography, these writings have received very imperfect examination and criticism.

The Spaniards have been severely censured for their remiss-

ness in omitting to record the wonders of the Indian civilization which they are supposed to have met with, and especially for having failed to tell us about the towns and highly decorated buildings the ruins of which have been frequently described by modern travellers; but this censure appears to be to a great extent unmerited, for their writings, if carefully searched, do reveal a considerable amount of information about the Indians as they found them, and they failed to describe the ancient buildings because, as I hope to prove later, in many cases these buildings were even then as deeply buried in the recesses of the forests as they are at the present day.

We naturally want to know more about this lost civilization, and there are many ways of attacking the problem. First of all, there is a large amount of correspondence, and a great number of reports written by the soldiers, officials, ecclesiastics, and other early settlers in the New World, which, not bearing on the main historical events of the conquest, have escaped publication, but which, if carefully examined, may afford valu-

well as some original stone carvings, are now exhibited in the Architectural Court of the Museum. Maps, plans, photographs, and drawings, are in course of publication in the *archæologi* a section of the "Biologia Centrali-Americana."

The Editor of this journal has asked me to give some general account of the work on which I have been engaged, and its results, and this I will now attempt to do; but I must ask the reader to bear in mind that I started on the work almost by chance, and without any previous training or archaeological knowledge, that I am but little acquainted with the literature of the subject, and have almost entirely confined my efforts to the collection of accurate copies of sculptures and inscriptions, in hope that some students may be found willing to make use of them. The following notes must therefore not be looked on as anything more than an attempt to clear the ground before an attack which I hope some day to see made on a difficult problem.

The remains of the more civilized races of North America

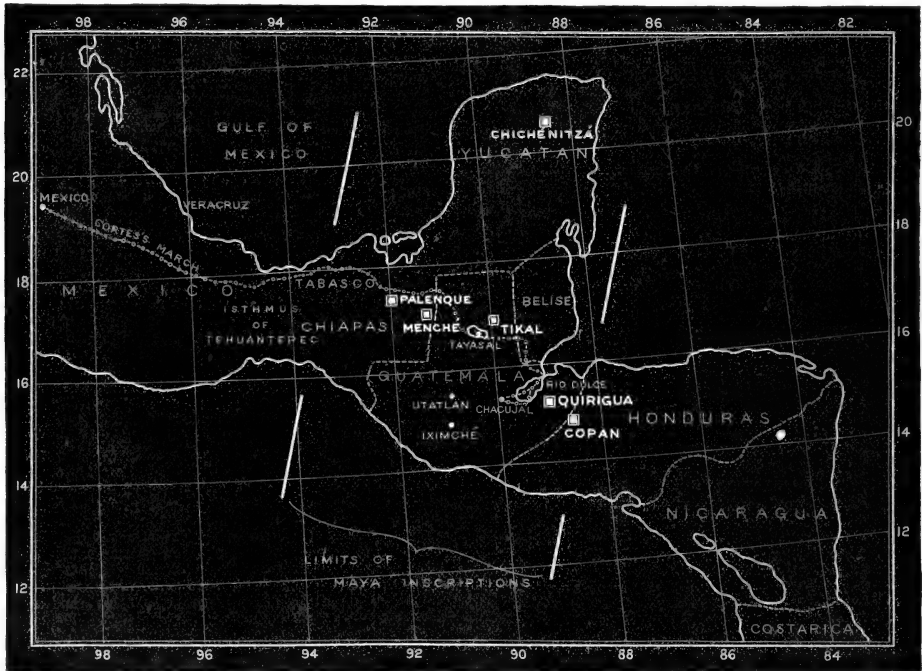

able information regarding the native Indians. Then a study of the customs, languages, and folk-lore of the living races, may throw much light upon the condition and belief of their fore-runners; and, above all, a careful examination of the burial-places and of the architectural and monumental remains, and their numerous hieroglyphic inscriptions, which lie hidden away in the vast forests, may reveal something of the history of the people who raised them.

It has been my good fortune to be able to devote my time during seven winters to the collection of materials which I trust may enable the study of Central American archæology to be pursued with greater ease and success than has hitherto been possible.

All the moulds of inscriptions and other sculptures made during my expeditions have been handed over by me to the authorities of the South Kensington Museum, and casts have already been taken from the greater number of them, which, as

can be traced from the Isthmus of Panama as far north as the ruined Pueblos in the Cañons of Colorado. This great extent of country can again be roughly divided into three portions—one extending from Colorado to the Isthmus of Tehuantepec, a second from Tehuantepec to a line running nearly along the western frontiers of Honduras and Salvador, which may be called the Maya district, and a third from this line to the Isthmus of Panama.

So far as I know, no remains of stone buildings have been found in this last district, but much pottery is found—some of which is distinguished by great beauty of form, as well as excellence of decoration.

It is in the centre province, which includes Guatemala, Chiapas, Tabasco, and Yucatan, that my collections have been made, and the accompanying map shows the most important ruins visited.

It is impossible within the compass of an article, and

without the aid of numerous plans and drawings, to give an adequate account of the ruins as they can now be seen, but the following short summary gives the characteristics of the principal groups found to the south of Yucatan:—

**Quirigua.**—Thirteen monoliths covered with elaborate carved decoration and inscriptions. These are of two classes, upright stelæ, of which six still stand erect, the tallest measuring 25 feet high from the ground, 5 feet across back and front, and 4 feet across the sides, and large rounded blocks of stone cut into the form of some grotesque animal, the largest of them weighing about 20 tons. No buildings remain standing, but there are numerous mounds, only one of which has been dug into, and was found to contain on its summit the ground-work of a stone-built temple.

**Copan.**—Sixteen stelæ averaging 12 feet in height, of which eight are now standing, and numerous other sculptured monuments. Both figures and inscriptions are carved in higher relief than at Quirigua. Numerous stone-faced mounds, which can be ascended by well-laid stone stairways. There is no sign of a wall either of house or temple above ground, but the lower parts of both temples and houses can be found by digging into the masses of broken masonry on the tops of the mounds and terraces. Broken stone ornaments, which once decorated these buildings, are found lying in profusion at the foot of the mounds.

**Menché.**—A town built on stone-faced terraces rising one above the other from the banks of the River Usumacinta. There are many mounds of stone, and there are a few stone-roofed houses and temples still standing with carved stone lintels over the doorways. No separate carved monolithic monuments of importance.

**Tikal.**—Five cell-like temples with enormously thick walls, raised on pyramidal foundations of great height. The measurement of the largest, from the ground to the top of the temple, is about 160 ft., the base of the foundation measuring about 280 ft. square. These temples had beautifully carved wooden lintels over the doorways. Some of this carved wood is now preserved in the Museum at Basie, and some (a few smaller pieces) in the British Museum. There are several other smaller temples and numerous houses with stone roofs still standing. All these buildings had wooden lintels over the doorways, and some of the wooden beams are in a perfect state of preservation. There are seven or eight small stelæ, usually flat slabs of stone with carving on the front and sides only, all unfortunately much damaged and weather-worn.

**Palenque.**—One group of stone-roofed houses, commonly known as the palace, raised on a high stone-faced foundation. Four separate temples on similar foundations, and numerous other temples, houses, and tombs, some half-ruined, and others mere heaps of stone and rubbish. Only one carved monolith has been found which stood apart, but several large stone slabs beautifully carved with figures and inscriptions in low relief were let into the interior walls of the temples, and almost all the buildings have been lavishly ornamented with figures and inscriptions moulded in a hard and durable stucco.

The principal fact ascertained from the examination of the remains throughout this district (including Yucatan) is that the art exemplified both by monuments and buildings is one and the same, and that the inscriptions are all carved in the same characters.

The chief difference to be noted is that whereas in the ruins which I assume to be of earlier date the art and workmanship is lavished on the decoration of large monoliths, whilst the temples and other buildings are comparatively insignificant, as time went on the elaborate carving of separate stone monuments was neglected, and the whole efforts of the artists were devoted to the erection and adornment of larger and more imposing buildings, and the carved stone glyphs of the monoliths gradually gave way to stucco and painted inscriptions on the walls of the temples and to manuscript books.

The age to be ascribed to these remains is purely a matter of conjecture; but there are some historical facts which bear on the subject which I have already called attention to in another publication, but which may with advantage be here repeated.

Hernando Cortes, after the conquest of Mexico, started from that city in the year 1525, accompanied by some hundreds of Spaniards and a large number of Indians, with the intention of marching direct to Honduras. When Señor Cortes de Gayangos, in the year 1867, translated for publication by the Hakluyt Society the letter written by Cortes to Philip II. of

Spain, giving an account of this expedition, he states in the preface that:—"To determine the spots visited by him in this extraordinary march through almost impenetrable forests, swampy plains, or lofty mountains, has by some writers been pronounced a hopeless task; and though we possess the narrative of the stout-hearted and sturdy soldier, Bernal Diaz, who formed part of the expedition and carefully noted down its principal events; though the various provinces traversed by the devoted army have since been more or less explored by travellers of all nations, few are the indications—and those very slight—of the route they followed. He must have passed near the ruins of Palenque, since the small village of Las Tres Cruces is said to derive its name from three wooden crosses left in that locality."

A comparison of the recent and more accurate maps of Tabasco published by the Mexican Government, and of my own surveys in the region of the head waters of the Sarstoon and Mopan Rivers, with certain old maps and documents which have recently been brought to light from the Archives of the Indies at Seville, now enables us to trace Cortes's line of march with some degree of accuracy.

After passing the Isthmus of Tehuantepec, he found himself involved in the intricate waterways of the delta of the Tabasco and Grijalra Rivers. He and his followers suffered the greatest hardships, but after cutting their way through the tangled vegetation of the swamps, and with infinite patience and labour building bridges over the almost innumerable streams and lagoons, he crossed the River Usumacinta, somewhere in the neighbourhood of Tenosique.

There can be no doubt that towards the end of this part of this march, at a time when Cortes and his followers, lost in the forests of the delta, were suffering the last extremities of hunger, and were eagerly searching for a track which might lead them to an Indian settlement—they were traversing a plain actually overlooked by the temples of Palenque, and not more, and probably much less, than twenty miles distant from them. If Palenque had then been the great centre which it at one time must have been, and if the foot-hills of the Sierra on which it stands had then been as thickly peopled as the numerous remains indicate, it would have been impossible for a body of men as numerous and as much on the alert as were the followers of Cortes, to have missed the discovery of the many tracks which must have led thither.

Moreover, Cortes had been furnished with a map of the country, prepared by the Indian chiefs at Guacacualco; and although it has been suggested that the chiefs systematically deceived him so as to prevent his visiting their richest and most sacred towns, such deception was not likely to have been successful with him, and it is still less likely to have imposed upon the large number of Mexican Indians who accompanied him. Yet, if Palenque was then inhabited, we are compelled either to believe that Cortes and his followers were indeed successfully imposed upon, or to give credit to the still more unlikely alternative that the Indian auxiliaries preferred to suffer such extremities of hunger that they were driven to eat the bodies of their companions who had died by the way, rather than give any information which would have been of service to their foreign leaders.

It hardly appears possible, therefore, to resist the conclusion that, in the year 1525, Palenque was already abandoned, and lost in the forest.

But if the information afforded to Cortes is to be relied on, then the same fate must also have overtaken the town of Meuché on the Usumacinta, for Cortes was strongly advised by the natives not to continue his march along the banks of the river (and if he had done so he must have passed near the site of the ruins of Menché), as the country in that direction was uninhabited.

Accepting this advice, Cortes took the road by Acalá and Peten, and thence through part of what is now British Honduras, to the mouth of the Rio Dulce.

The inhabitants of Acalá appear to have been more civilized than any others whom Cortes met with during his long march. He states that the country was thickly peopled, and that the towns were large and full of mosques or idol-houses, yet no important ruins have ever been found in that district, and neither Cortes nor Bernal Diaz gives us any description which would lead us to suppose that they ever met with such imposing buildings as those still standing at Palenque or Menché.

From Acalá the expedition marched through a very thinly-peopled country until they arrived at the Lake of Peten.

Cortes visited the town of Tayasal, built on a small island in the lake, which, we are told, was the chief town of the district, and which was doubtless then, as it was later, the stronghold of the warlike Itzaes. Now, fortunately, we know something of the subsequent history of this town, for Tayasal was visited by missionaries from Yucatan in 1618, 1619, and 1623. This last missionary expedition ended disastrously, as the missionary and his followers were murdered by the natives; and we then have but scanty information about the Itzaes until the country was invaded by the Spaniards from Yucatan, and Tayasal captured in 1697. A curious story shows us that Tayasal is not likely to have suffered any serious disturbance between Cortes's visit and the year 1618.

In his letter to the King he states that, "At this village, or, rather, at the plantations that were close to the lake, I was obliged to leave one of my horses, owing to his having got a splinter in his foot. The Chief promised to take care of the animal and cure him, but I do not know if he will succeed, or what he will do with him."

On the day after the arrival of the missionary fathers Fuenzalida and Orbita, in 1618, the Chief of the Itzaes showed them round the town, "in the middle of which, on the rising ground, were numerous and large buildings, 'cues' or oratories of their devilish and false gods. Entering into one of them, they saw in the centre of it a large idol in the form of a horse, well modelled in stone and plaster. It was seated on the ground, on its haunches.

"These barbarians revered it as the God of Thunder, and called it Tzimindiac, which means 'the horse of thunder and lightning.'"

This sight was too much for the religious zeal of Padre Orbita, who, seizing a great stone, jumped on to the idol and hammered it to pieces. It is hardly necessary to add that the Chief had the greatest difficulty in saving the lives of the missionaries from his infuriated people, and that they were compelled to leave the island at once.

It was afterwards learnt from the natives that they had thought the horse to be the god of thunder and lightning because they had seen the Spaniards firing their guns from horseback, and that when they found the horse to be ill, "they gave it to eat fowls and other meat, and presented it with garlands of flowers, as it was their custom to do when their own chiefs were ailing," and that, on its death, a council of chieftains was called, and it resolved to make an image of the horse in stone.

In the year 1700, the historian Villagutierrez published a detailed account of the conquest of Itza by the Spaniards, and a description of the town of Tayasal, stating that "it was full of houses, some with stone walls more than a yard high, and, above these, wooden beams and roofs of thatch, and others of wood and thatch only"; and "of the twenty-one oratories which General Ursua found in the island, the principal and largest was that of the high priest Quincanek, cousin of the king Canek; this was rectangular (*cuadrada*), with a beautiful breastwork (*pretil*) and nine handsome steps, and each front was about twenty yards long and very high."

Speaking from memory, I should say that the island is not more than 500 yards across, and there are no signs whatever at the present time of any ancient foundations. It is now covered with poorly-built adobe houses, and in the centre is a church, which probably occupies the site of the ancient 'cues.' Now, within a day's walk from the north shore of the lake are the very remarkable ruins of Tikal, of which a short description has already been given; yet nothing whatever is told us either by Cortes, by the missionaries, or by Villagutierrez, of the existence of a town on this site, and the ruins were unknown to the Spaniards until the year 1848.

The missionaries, on their journeys from the Spanish outpost at Tipu to Tayasal must have passed within a few miles of the site of the ruins; and it is impossible to believe that, so long as Tikal was inhabited, Tayasal could have been the chief town of the district, or, indeed, that Tikal could have been inhabited at all without the fact coming to the knowledge of the Spaniards.

If any further evidence were needed to show that the great structures raised during the epoch of higher civilization had already been deserted at the time of the Spanish conquest, it can be found in what Cortes himself states with regard to the town in Guatemala which he calls Chacujal.

When, after having crossed the base of the peninsula of Yucatan, the starving army arrived at the mouth of the Rio

Dulce, it was only to find the Spanish colony it had come in search of reduced to a similar extremity of famine.

The scanty Indian population in the neighbourhood had been rendered hostile by the exactions of the settlers, and it was immediately necessary to scour the country for long distances in search of food. The most important of these raids, and, indeed, the only successful one, was led by Cortes himself, who landed on the south side of the Golfo Dulce, and marched about two leagues inland (when he must have been within about twelve to fifteen miles of the site of the ruins of Quirigua), and then turned along the mountain-range to the south of the Rio Polochic, and finally succeeded in reaching Chacujal, which is situated between two small streams which run into the Polochic. The inhabitants had all fled, but Cortes was fortunate in finding a large store of Indian corn, and other food.

Cortes writes of the town as follows:—"Marching through the place we arrived at the great square, where they had their mosques and houses of worship, and as we saw the mosques and buildings round them just in the manner and form of those at Culua" (on the coast of Mexico), "we were more overawed and astonished than we had been hitherto, since nowhere since we had left Acala had we seen such signs of policy and power. . . . On the following morning I sent out several parties of men to explore the village, which was well designed, the houses well built, and close to each other." I can find no record whatever of Chacujal subsequent to the date of Cortes's visit; but in 1884 I myself visited the ruins of the town, guided by Cortes's own description of the site. The ruins are now completely buried in the forest, but there was little difficulty in tracing the general plan of the town, and making out the foundations of the principal buildings.

It is easy to understand how Cortes may have been favourably impressed with the flourishing appearance of the place after his terrible and tedious journey through the forest, yet it is quite clear from the ruins that the structures themselves could never have been of any considerable importance. The walls of the principal buildings had only been built of stone to half their height, and the superstructure and roof must have been made of some perishable material—a great contrast to the thick stone walls and heavy stone roofs at Palenque, Tikal, Menché, and Copan. Another point of importance is that the plan and method of construction of the buildings at Chacujal is similar to that of the ruins on the hill-tops a little further inland near San Jeronimo, Rabinal, and Cubulco, some of which I have visited. These were undoubtedly the strongholds of those Indians of the Tierra de Guerra to whom no high culture has ever been attributed, and who were induced by the Padre Las Casas to leave their fastnesses and settle in the plain of Rabinal in the year 1537.

It can therefore now be stated without doubt that, although Cortes and his followers on his march from Mexico to Honduras passed within a short distance of several of the sites of the most important ruins in Central America, they heard nothing of their existence as living cities.

Let us now consider the case of the often-described ruins of Copan on the northern frontier of Honduras.

The earliest information dates back to the year 1576, when the ruins were visited by Palacio del Rio, who described them in a letter written to King Philip II, of Spain. After giving an account of the sculptured monoliths, he mentions the numerous mounds which could be ascended by stone stairways, but he says nothing whatever about houses or temples, which such a careful observer as Palacio could not have omitted to mention had they then been in existence. He further states in his letter that it was impossible to believe that the scanty Indian population of the districts could have raised such monuments as he found at Copan, and that his efforts to elicit information from the leaders of the Indians dwelling in the neighbourhood only showed that all knowledge of the people who had raised these monuments was lost in the mists of tradition.

Enough has now been said to show that the most important ruins in the whole of this Maya district (outside of Yucatan) were never known to the Spaniards as the sites of inhabited towns, and it now remains to say only a few more words about those towns in which the conquerors actually found the people dwelling. The descriptions already quoted from early writers, or given from my own observations of the ruins in the cases of Tayasal and Chacujal, give some idea of what these towns were like; and the correctness of these descriptions is strengthened by the results of a careful examination which I have made of the sites

of the towns of Uxatlan and Iximché, the capitals of the Quiché and Cachiuels, who were the most powerful tribes in Guatemala when Alvarado conquered the country. Although the remains of these towns, which were known for certain to have been inhabited at the time of the Spanish conquest, bear some similarity in plan and arrangement to the older ruins, there is the great distinction to be observed that in no instance is there any indication of the former existence of stone-roofed buildings, that there are only a few stones which show any trace of ornamental carving, and that of the roughest description, and that there are no remains of any carved inscriptions.

It may be as well to say a word of warning against the exaggerated accounts of the magnificence of the Indian towns of Guatemala at the time of the conquest which have found their way into the histories of the country by Fuentes, Juarros, and others, and are still alluded to and sometimes accepted as facts by modern travellers. To give only one instance. In describing the palace of the Quiché kings at Uxatlan, dimensions are given for this palace which exceed the whole extent of the land on which any building is possible, for the site of the town is most clearly defined, and limited by the great "barranca" or rift, some hundreds of feet deep, which almost encircles it. It was no doubt this peculiar situation, that of an almost inaccessible peninsula in the middle of an undulating plain, which gave the site so much value in the eyes of the Quichés.

There is, then, a clearly marked difference between the remains of the towns of which we have some historical knowledge and the more ancient ruins.

But when one considers the fair state of preservation of some of the buildings at Palenque and Menché, and the presence of sound wooden beams in the temples and houses at Tikal, it is hardly possible to ascribe even to these ruins any very great antiquity.

From my own observation of the state of the ruins themselves, and the style of art displayed in the carved ornaments and inscriptions, I should feel inclined to give to Quirigua the earliest date, Copan the next, then Menché, Palenque, and Tikal, in the order named.

We must now turn our attention to the province of Yucatan.

The central portion of the peninsula has always been more or less a *terra incognita*. The Spaniards never really brought its inhabitants into complete subjection, and to this day it is peopled by hostile Indians, and no Spaniard dares to enter it.

If this country contains traces of the old civilization, nothing definite is known of them. The northern portion of the peninsula was brought completely under Spanish control, and is known to be studded with the remains of groups of ancient stone buildings.

It was on the north-east coast of Yucatan that the Spaniards first came into contact with Indians who used stone as a building material, and there can be but little doubt that some of the many ruined structures now to be seen were inhabited by the natives at the time of the conquest.

I am myself inclined to the opinion that the north of Yucatan was the last stronghold of the more cultivated branch of the Maya race after that race had either been driven out of, or under the stress of unknown adverse circumstances had retrograded in, the country to the south. But it does not follow that the Indians of Yucatan were at the height of their power and prosperity when the Spaniards came amongst them. In fact, their conquerors learnt from them that for some time previously the country had been troubled with civil wars and dissensions, and that Mayapan, once the chief town, had been destroyed and abandoned. It seems quite probable that this statement may be enlarged on to a considerable extent, and that we may consider the country to have been in a state of decadence, and that not one but many of the chief centres of population had been more or less abandoned. However, the temples and sacred edifices appear still to have been held in reverence after the population had moved away, and were visited during festivals, and may have been kept in some sort of repair by the priests; much in the same way as I believe the ruined dagobas and temples at Pollonaruwa and Anuradhapura are revered and visited by the people of Ceylon.

This appears to me to have been most probably the case with regard to the important buildings which still mark the site of what must have once been the large town of Chichén Itzá.

It has, I know, been stated that Chichén was inhabited at the time of Francisco de Montejo's first abortive effort to conquer Yucatan, and that the Spaniards were for some considerable time encamped in the town; but this statement does not appear

to me to be supported by any sufficient evidence. Nevertheless, religious ceremonies were so recently observed in Chichén Itza, that, in answer to a despatch from Spain, a committee of the settlers in the neighbouring town of Valladolid were able to give some account of them in the year 1579.

My personal experience of the ruins in Yucatan is limited to a hasty visit to Labna and Uxmal, and a residence of five months in one of the ruined temples of Chichén Itzá. At Chichén my clearings and surveys extended over an area of nearly a mile square, and although this appeared to include all the principal edifices, it was impossible to walk into the bush in any direction from the edge of this area without coming on the traces of stone buildings.

The surface of the ground, even in the centre of the town, although generally level, was in some places composed of cavernous and broken limestone rock, and these portions had apparently been walled off as unfit for buildings. But, wherever the ground was suitable, there were numerous traces of slightly constructed buildings in addition to the more solid structures.

The hieroglyphic inscriptions at Chichén are few in number, and with one small exception very poorly carved, but there is enough to show that they did not differ in character from those in Guatemala and Chiapas. There is, however, one great distinction between the sculptures in Yucatan and the country to the south which must not be overlooked. In the latter there is an almost entire absence of weapons of war, and the figures of women occupy a prominent position. In Yucatan the change is complete: there are no women represented in the sculptures, and every man is a warrior armed with spears and throwing-stick.

Whether the Maya civilization extended to Yucatan during the time that it flourished at Copan or Palenque, it is at present impossible to determine; but I strongly incline to the opinion that all the buildings now standing in Yucatan are of a later date. It may be perhaps allowable to state the case somewhat as follows:—

That the civilized portion of the Maya race have at some time occupied all the country lying between the Isthmus of Tehuantepec and the western frontiers of Honduras and Salvador (excepting perhaps a strip of country along the Pacific sea-board); that this people spoke the same or nearly allied languages, which they wrote or carved in the same script; that they were followers of the same religion, and built stone-roofed temples and houses decorated with the same class of design and ornament.

That at the time of the Spanish conquest they had entirely abandoned all their towns and religious centres in the country to the south of Yucatan, although the good state of preservation of many of the buildings at the present time precludes the idea that this desertion of their towns could have ante-dated the arrival of the Spaniards by very many years. That the people whom the Spaniards encountered in this part of the country, although they may have been allied in blood to the Mayas, were undoubtedly in a lower state of culture, and that an examination of the sites of their principal towns yields no signs of the artistic culture which is universally found in the older ruins.

That in Yucatan, where the Spaniards found a dense population of Maya Indians, and encountered a fierce and stubborn resistance, there are still to be seen numerous remains of ancient buildings, both larger and in better preservation than those in Guatemala and Chiapas, but built in the same manner, decorated with the same ornaments, and with inscriptions carved in the same hieroglyphic script. That there is evidence, from the early Spanish writings, that some at least of those buildings were still occupied at the time of the conquest; but that both the observations of the Spaniards themselves, as well as the reports subsequently gathered by them from the Indians, point to the conclusion that the country was in a state of decadence, and that many of the larger centres of population had already been abandoned, although the more important religious edifices may still have been revered and kept in repair.

The early Spanish writers make frequent allusion to the large number of books written and preserved by the natives of Yucatan. These books were written in hieroglyphic characters in the Maya language, which, it must be remembered, is still spoken by the whole of the Indian population of Yucatan, as well as by nearly all the half-breeds and Spaniards.

Unfortunately, every effort was made by the Spanish priests to destroy this literature, which they looked on as the work of the devil; and it is very doubtful whether a single fragment of hieroglyphic manuscript is now in existence in the whole peninsula.

One of the chief of the iconoclasts was Archbishop Diego de Landa; but, luckily, his zeal was tempered by a considerable appreciation of the ingenuity of the Indians, and an interest in their manners and customs, which induced him to make some notes on their method of writing and recording events.

It is to this that we owe what is commonly known as "Landa's alphabet"; but, as this was an attempt to make an alphabet of a language which in all probability was not written alphabetically but syllabically, it was a signal failure, and has proved, to the few scholars who have attempted to employ it, about as puzzling as the hieroglyphics themselves. However, it may ultimately be of some use, and it was accompanied by an explanation of the calendar system, and a list of the signs for the days and months, with their names, which is of the greatest value.

Although no Maya books are known to exist in America, three examples of what are undoubtedly genuine Maya manuscripts have turned up in Europe.

No information whatever is forthcoming as to how they got here, but it is not unlikely that they were sent over as curiosities at the time of the Spanish conquest, and were afterwards lost sight of.

They are the "Codex Troano," now preserved in the Archaeological Museum at Madrid, a chromolithographic copy of which was published by the Abbé Brasseur de Bourbourg; the "Dresden Codex," preserved in the Royal Library at Dresden, of which a beautiful photolithographic copy has been published under the direction of Prof. Forsteman; and the "Codex Peresianus," in the Bibliothèque Nationale at Paris. Another manuscript at Madrid, which has been called the "Codex Cortesianus," appears to be only a detached portion of the "Codex Troano."

An examination which I have made of the two first-mentioned Codices leaves no doubt on my mind about the similarity of the written to the carved inscriptions. Many of the glyphs are identical, and others only vary as much as might be expected by the change from carving on stone to writing on paper. In addition to this evidence of the eyes, there is the distinct statement of Cogolludo, the historian of Yucatan, that the Indians had "characters by which they could understand one another in writing, such as those yet seen in great numbers on the ruins of their buildings."

So that we arrive at the important conclusion that the language of the carved inscriptions of Copan, Quirigua, and Palenque is still a living tongue, although it has doubtless been much changed in the course of years.

ALFRED P. MAUDSLAY.

### UNIVERSITY AND EDUCATIONAL INTELLIGENCE.

CAMBRIDGE.—Mr. C. E. Ashford, B.A. of Trinity College, has been appointed Assistant Demonstrator of Physics in the Cavendish Laboratory.

Dr. William Ewart and Mr. Frederick Treves have been appointed additional examiners in Medicine and Surgery respectively.

The Cavendish Professor announces a course of lectures on Electrolysis and Solution, to be given by Mr. W. C. D. Whetham on Thursdays and Saturdays during the present term. Seventeen candidates were approved for the diploma in Public Health at the extra examination held at the beginning of the month.

T. Clifford Allbutt, M.D., F.R.S., the newly appointed Regius Professor of Physic, has been elected to a Fellowship at Gonville and Caius College.

The Shuttleworth Scholarship in Botany has been awarded to I. H. Burkill, B.A., Assistant Curator of the Herbarium.

The memorial in Westminster Abbey to the late Prof. J. C. Adams, will be placed in the sill of the window on the north side, nearest to the monument of Newton. A large and very influential committee has been formed for the purpose of establishing the memorial.

### SCIENTIFIC SERIALS.

*American Journal of Science*, March.—Mount St. Elias and its glaciers, by Israel C. Russell. Account is given of the country explored by two parties sent to Alaska by the National Geographic Survey, in connection with the U.S. Geological

Survey, in 1890 and 1891.—Hudson River "Fiord," by Dr. Arthur M. Edwards.—Contributions to mineralogy, No. 52, by F. A. Genth; with crystallographic notes by Samuel L. Penfield. The minerals described are hübnerrite, hessite, bismutite, and natrolite.—Tschermak's theory of the chlorite group and its alternative, by F. W. Clarke.—Recent fossils near Boston, by Warren Upham. Fossil marine shells of the post-Glacial epoch have been lately discovered near Boston, indicating slight recent changes in the relative levels of land and sea, and proving considerable changes in the temperature of the sea there.—The highest old shore line on Mackinac Island, by F. B. Taylor.—On the nature of colloid solutions, by C. E. Linebarger. It is generally believed that solutions of colloid substances, such as albumen or silicic acid, differ in their nature from solutions of crystalloid substances. The author's experiments indicate that colloid solutions are solutions in the ordinary acceptation of the term, and not "suspensions."—Observations upon the structural relations of the Upper Huronian, Lower Huronian, and Basement Complex on the north shore of Lake Huron, by Raphael Prowley and C. R. Van Hise.—A phasemeter, by John Trowbridge. The phasemeter is an instrument devised for the investigation of questions of the phase of alternating electric currents in transformers and in branch circuits. Two telephone diaphragms have mirrors fixed upon them. A spot of light reflected from one of the mirrors is given a horizontal movement when the diaphragm is vibrating, while the other mirror, when its diaphragm moves, gives a spot of light a vertical motion. By the combination of the two motions, figures are obtained similar to those of Lissajous in the case of tuning-forks; and from these, the difference in phase of the currents which set the diaphragms in motion can be found.—Preliminary report of observations at the Deep Well, Wheeling, West Virginia, by William Hallock.—Mount Bob, Mount Ida, or Snake Hill, by T. W. Harris.

April.—On the action of vacuum discharge streamers upon each other, by Dr. M. I. Pupin. The experiments described show that two electric current filaments in a rarefied gas may repel each other in cases where electrodynamic action would produce an attraction. The repulsion does not appear to be due to electrostatic action, but rather to "a strain in the vacuum produced by the peculiar distribution of the gas pressure resulting from the peculiar distribution of temperature."—On a melilite-bearing rock (Alnoite) from Ste. Anne de Bellevue, near Montreal, Canada, by Frank D. Adams.—On an azure-blue pyroxenic rock from the Middle Gila, New Mexico, by George P. Merrill and R. L. Packard.—On the correlation of moraines with raised beaches of Lake Erie, by Frank Leverett.—Magnesium as a source of light, by Frederick J. Rogers. The results of this investigation are summed up as follow:—(1) The spectrum of burning magnesium approaches much more nearly that of sunlight than does the spectrum of any other artificial illuminant. (2) The temperature of the magnesium flame, about 1340° C., lies between that of the Bunsen burner and that of the air-blast lamp, although the character of its spectrum is such as would correspond to a temperature of nearly 5000° C. were its light due to ordinary incandescence. (3) The "radiant efficiency" is 13½ per cent., a value higher than that for any other artificial illuminant, excepting, perhaps, the light of the electric discharge *in vacuo* for which Dr. Staub, of Zürich, has found an efficiency of about 34 per cent. (4) The radiant energy emitted by burning magnesium is about 4630 calories per gram of the metal burned, or 75 per cent. of the total heat of combustion, as compared with 15 per cent. to 20 per cent. in the case of illuminating gas. (5) The thermal equivalent of one candle-power-minute of magnesium light is about 2.4 lesser calories, as against 3.5 to 4.0 for other artificial illuminants. (6) The total efficiency of the magnesium light is about 10 per cent., as compared with 0.25 per cent. for illuminating gas. (7) Taking into consideration the greater average luminosity of the rays of the visible spectrum of the magnesium flame, it is certain that *per unit of energy expended, the light-giving power of burning magnesium is from fifty to sixty times greater than that of gas.*—A method for the quantitative separation of barium from calcium by the action of amyl alcohol on the nitrates by P. E. Browning.—On plicated cleavage foliation, by T. Nelson Dale.—Geological age of the Saganaga syenite, by A. R. C. Selwyn.—A third occurrence of peridotite in Central New York, by C. H. Smith.—A fulgurite from Waterville, Maine, by W. S. Bayley.—Mineralogical notes on brookite, octahedrite, quartz, and ruby, by G. F. Kunz.—Recent polydactyle horses, by O. C. Marsh.



## SOCIETIES AND ACADEMIES.

LONDON.

**Entomological Society, April 13.**—Mr. Henry John Elwes, Vice-President, in the chair.—Mr. R. McLachlan, F.R.S., exhibited specimens of a Caddis-fly remarkable for the abbreviated wings of the male, the female having fully developed wings. He alluded to the *Perlida* as including species in which the males were frequently semi-apterous. Dr. Sharp, F.R.S., inquired if Mr. McLachlan was aware of any order of insects, except the Neuroptera, in which the organs of flight were less developed in the male than in the female. Mr. C. G. Barrett and Mr. H. J. Elwes cited instances amongst the *Bombycida* in which the wings of the male were inferior in size and development to those of the female.—Dr. Sharp exhibited specimens of both sexes of an apparently nondescript Phasmid insect allied to *Orobia*, obtained by Mr. J. J. Lister in the Seychelles Islands, together with *Phyllium gelonus*. He also exhibited specimens of both sexes of an insect remarkable for its great general resemblance to the *Phasmiidae*, though without resemblance, so far as is known, to any particular species. In reference to the *Phyllium*, Dr. Sharp called attention to the fact that the similarity of appearance of parts of their organization to portions of the vegetable kingdom was accompanied by a similarity, amounting almost to identity, of minute structure. He said that it had been stated that the colouring-matter is indistinguishable from chlorophyll, and that Mr. Lister had informed him that when in want of food a specimen of the *Phyllium* would eat portions of the foliaceous expansions of its fellows, although the *Phasmiidae* are phytophagous insects. The resemblance to vegetable products reached its maximum of development in the egg; and M. Henneguy had observed that when sections of the external envelope of the egg of *Phyllium* are placed under the microscope no competent botanist would hesitate to pronounce them to belong to the vegetable kingdom.—Mr. Barrett exhibited, for Major J. N. Still, a specimen of *Notodonta bicolora*, which had been captured in a wood near Exeter. Major Still had stated that the captor of the specimen was unaware of the great rarity of the species. Mr. Barrett also exhibited, for Mr. Sydney Webb, some remarkable varieties of *Argynnis adippe* and *Cenonympha pamphilus*; also two specimens of *Apatura iris*, and two of *Limenitis sybilla* in which the white bands were entirely absent.—The Hon. Walter Rothschild exhibited, and contributed preliminary notes on, some hundreds of Lepidoptera, representative of a collection of about 5000 specimens recently made by Mr. W. Doherty, in the south-west of Celebes. Many of the species were new, and others very rare. Mr. Elwes, Colonel Swinhoe, and Mr. S. Stevens commented on the interesting nature of this collection.—Mr. E. B. Poulton, F.R.S., gave a lecture "On the Denudation of the Scales in certain Species of Lepidoptera," and illustrated it by a large number of photographs shown by means of the oxy-hydrogen lantern. Mr. G. F. Hampson, Mr. Elwes, and Mr. Poulton took part in the discussion which ensued.

**Royal Meteorological Society, April 20.**—Dr. C. Theodore Williams, President, in the chair.—Reference was made to the death of Dr. J. W. Tripe, who had held the office of Council Secretary for the last twenty years, and a resolution of sympathy with the family was passed by the meeting.—The following papers were read:—Anemometer comparisons, by Mr. W. H. Dines. This was a report on a valuable series of experiments which have been carried out at the request of the Council of the Society, with the view of obtaining a direct comparison of the various anemometers in common use, so that some opinion might be formed as to which type of instrument is the most suitable for general purposes. The Meteorological Council have defrayed the cost of the work. The anemometers which were compared were—(1) Kew pattern Robinson; (2) self-adjusting helioid; (3) air meter; (4) circular pressure plate (one foot in diameter); and (5) a special modification of tube anemometer. Most of these instruments are of the author's own invention, as well as the apparatus for obtaining automatic and simultaneous records from all the instruments upon the same sheet of paper. It appears that the factor of the Kew pattern Robinson is practically constant, and must lie between 2.00 and 2.20. The helioid anemometer is quite independent of friction for all excepting light winds, and different sizes read alike, but it is not so simple in construction as the cup form. The air meter consists of a single screw

blade formed of thin aluminium, and made as nearly as possible into the exact shape of a portion of a helioid. A similar instrument with a larger blade, and with the dial protected from the weather, would probably form a useful and correct anemometer. It would be light, and offer a very trifling resistance to the wind. The oscillations of the pressure plate must have been considerably damped by the action of the floating weight, but as it was, they were sufficiently violent. It seems probable that the remarkably high values sometimes given by the Osler pressure plate may be due to the inertia of the moving parts. The tube anemometer appears to possess numerous advantages. The head is simple in construction, and so strong that it is practically indestructible by the most violent hurricane. The recording apparatus can be placed at any reasonable distance from the head, and the connecting pipes may go round several sharp corners without harm. The power is conveyed from the head without loss by friction, and hence the instrument may be made sensitive to very low velocities without impairing its ability to resist the most severe gale.—The hurricane over the West Indies, August 18-27, 1891, by Mr. F. Watts. The author has collected a number of observations on this violent hurricane, which on August 18 swept from the Atlantic into the Caribbean Sea, and moved in a north-north-westerly direction over San Domingo, and thence northward and eastward. At Martinique the barometer, which at 5.30 p.m. stood at 29.80 inches, fell to 28.38 inches at 8.15 p.m., during the passing of the centre of the cyclone.

**Chemical Society, March 30.**—Annual General Meeting.—Prof. A. Crum Brown, F.R.S., President, in the chair.—The President delivered an address, in the first part of which he referred to the favourable position of the Society. In the remainder of his address he dwelt chiefly on the work which is being done on the border-lines of chemistry proper, referring both to that by which an approach is gradually being made towards understanding the chemistry of Nature's organic laboratory, and to the solution of chemical problems by the application of mathematical and physical methods of inquiry. A vote of thanks to the President was carried by acclamation.—After the usual reports by the officers of the Society had been presented, a ballot was taken for the election of officers and Council for the ensuing year. The following were subsequently declared elected:—President: A. Crum Brown, F.R.S. Vice-Presidents who have filled the office of President: Sir F. Abel, F.R.S.; W. Crookes, F.R.S.; E. Frankland, F.R.S.; J. H. Gilbert, F.R.S.; J. H. Gladstone, F.R.S.; A. W. Hofmann, F.R.S.; H. Müller, F.R.S.; W. Odling, F.R.S.; W. H. Perkin, F.R.S.; Sir L. Playfair, F.R.S.; Sir H. E. Roscoe, F.R.S.; W. J. Russell, F.R.S.; A. W. Williamson, F.R.S. Vice-Presidents: A. V. Harcourt, F.R.S.; W. N. Hartley, F.R.S.; J. Pattinson; W. Ramsay, F.R.S.; W. A. Tilden, F.R.S.; R. Warington, F.R.S. Secretaries: H. E. Armstrong, F.R.S.; J. M. Thomson. Foreign Secretary: R. Meldola, F.R.S. Treasurer: T. E. Thorpe, F.R.S. Ordinary members of Council: H. Bassett; N. Collie; H. Dixon, F.R.S.; J. Ferguson; R. J. Friswell; J. Heron; M. M. P. Muir; F. J. M. Page; W. H. Perkin, Jun. F.R.S.; S. U. Pickering; J. A. Voelcker; W. P. Wynne.—Correction of a note on a new acid from camphoric acid, by W. H. Perkin, Jun. The author desires to express regret that he had overlooked a previous paper by Damsky, in which an account is given of the acid recently described by him as new.

**Mathematical Society, April 14.**—Prof. Greenhill, F.R.S., President, in the chair.—The following six foreign mathematicians were elected Honorary Members of the Society, viz. Messrs. Poincaré, Hertz, Schwarz, Mittag-Leffler, Beltrami, and Willard Gibbs.—The following short communications were made:—Second note on a quaternary group of 51,840 linear substitutions, by Dr. Morrice.—Note on the skew surfaces applicable upon a given skew surface, by Prof. Cayley, F.R.S.—Mr. A. B. Kempe, F.R.S., made an *impromptu* communication on regular graphs.—Mr. J. J. Walker, F.R.S., Dr. M. J. M. Hill, Lieut.-Colonel Cunningham, and the President joined in the discussion on the above communications.

EDINBURGH.

**Royal Society, April 4.**—Sir Arthur Mitchell, Vice-President, in the chair.—Dr. Thomas Muir read a paper on a problem of Sylvester's in elimination, and also a note on Prof. Cayley's proof that a triangle and its reciprocal are in

perspective.—Prof. Blackie read a paper on the most recent phases of Greek literary style. The style of the educated Greek and the popular style were brought into closer correspondence than previously at the commencement of the present century, chiefly through the influence of Coraes. In this paper Prof. Blackie investigates the result of that amalgamation. Since 1830, the development of the Greek language has been most marked. The higher classical style has been constantly gaining ground, so that popular and literary Greek now differs as little from ancient classical Greek as Scotch does from English; while, previous to the time of Coraes, they were as distinct as present-day English is from the English of Chaucer. The author gives examples of the deviations of the literary and popular Greek of various epochs from ancient Greek, which prove a rapid return to the ancient purity of language. Thus, while in twelve lines of Romaine Greek eighteen or twenty deviations from the pure style may be found, in twelve lines of modern Greek only two or three such deviations appear. In the first five verses of the second chapter of Luke, nineteen deviations occur in the Romaine New Testament, while in the same passage in the English Bible Society's version of 1890 only four are found. In two pages of a recent number of a Greek newspaper only two deviations occur.—Dr. Berry Haycraft communicated a contribution, by Mr. F. E. Beddard, to the anatomy of *Sutroa*

## PARIS.

Academy of Sciences, April 19.—M. d'Abbadie in the chair.—Calculation of the diminution which is experienced by the mean pressure on a fixed horizontal plane, in the interior of a heavy liquid filling a basin and agitated by certain wave motions, by M. J. Boussinesq.—Note by M. Faye accompanying the presentation of celestial photographs obtained at Heidelberg by Dr. Max Wolf, Director of the Observatory. The photographs commented upon by M. Faye are those recently taken of a part of Cygnus, and that on which the trail of a new asteroid was detected; also a picture showing a shooting-star which crossed the field of observation during exposure. The photographs were taken by means of a portrait-lens 2½ inches in diameter.—On the optical measure of high temperatures, by M. A. Crova.—Researches on the formation of planets and satellites: memoir by M. E. Roger, presented by M. Jordan. The author has developed a complex relation connecting the distances of planets from the sun, and also one connecting the distances of planets from their satellites.—Observations of Swift's comet (1892 March 6), made with the Brunner equatorial of Lyons Observatory, by M. G. Le Cadet. Observations for position were made on April 3, 4, 8, 9, 11, and 15.—On differential invariants of a surface with respect to conformable transformations of space, by M. Arthur Tresse.—On the accuracy of comparisons of a *mètre à bouts* with a *mètre à traits*, by M. Bosscha.—Researches on the secondary wood of Apetales, by M. C. Houlbert.—On the relations existing between the form and nature of the beds of andalusite at Ariège, by M. A. Lacroix. It appears that at Ariège the form of the andalusite is characteristic in each bed to such an extent that, given a geological map of the region, it is possible to indicate *a priori* where the mineral would be found, and conversely, given a specimen of andalusite, the geological nature of the bed from which it was taken could be stated with very little chance of error. The facts described by M. Lacroix are thus as useful to the geologist as to the mineralogist.—On the loess of Turkestan, by M. Guillaume Capus.

## BRUSSELS.

Academy of Sciences, March 5.—The following communications were read:—The male of certain Caligides, and a new species of this family, by M. P. J. Van Beneden. The author describes (1) the male of *Pandarus Cranchii*; (2) the male and female *Pandarus affinis*, n. sp.; (3) a new species, *Chlamys incisus*; and (4) the male of *Dinematoura elongata*.—Theoretical determination of the radius of the sphere of molecular activity of liquids in general, by M. P. De Heen. The conclusion is arrived at that the radius of the sphere of activity is proportional to the product of surface tension into molecular volume.—On the curve in conic sections, by M. Cl. Servais.—Researches on the physiology of respiratory centres, by Dr. Alfred Bienfait. The author adduces evidence to show that a single respiratory centre, isolated by two transverse sections from the accessory respiratory centres, controls the movements of the glottis.—On a new ptomaine obtained by the culture of

*Bacterium Allii*, by Dr. A. B. Griffiths. In a former paper Dr. Griffiths described and named *Bacterium Allii*—a micro-organism found by him. This Bacteria produces a green pigment, soluble in alcohol, and possessing a particular absorption spectrum. In the presence of albuminoids, *Bacterium Allii* gives rise to a crystallizable ptomaine, which furnishes a chlorophanin, having the formula, according to analyses,  $(C_{10}H_{17}NH_2)Pt_2Cl_2$ . The analysis of the base gave the formula  $C_{10}H_{17}N$ , which corresponds to that of chloro-platinate.

## BOOKS, PAMPHLETS, and SERIALS RECEIVED.

BOOKS.—The Apodidae: H. M. Bernard (Macmillan).—Tanganyika: E. C. Hore (Stanf. rd).—Epidemics, Plagues, and Fevers: H. Rolle Russell (Sta. f rd).—Hand-book of Jamaica, 1892 (Stanford).—A Treatise on Physical Optics: A. B. Basset (Bell).—The Landfall of Lief Erikson, A.D. 1000: E. N. Horsf rd (Boston, Dammell and Upham).—A Guide to Electric Lighting: S. Bottono (Whitaker).—Elementary Lessons in Heat: S. E. Tillman, 2nd edition (Gay and Bird).—Les Altérations de la Personnalité: A. Binet (Paris, Alcan).—Thermodynamische Studien: J. W. Gibbs, translated by W. Ostwald (Leipzig, Engelmann).—English Botany, supplement to the 3rd edition, Part 1: N. E. Brown (Bell).—Progressive Mathematical Exercises, 2nd series: A. T. Richardson (Macmillan).  
PAMPHLET.—The Wheat Plant, h wth Feeds and Grows: W. Carruthers (also 8 diagrams) (W. and A. K. Johnston).  
SERIALS.—Proceedings of the Rochester Academy of Science, vol. 1. Brochures 1 and 2 (Rochester, N. Y.).—Brain, Part 57 (Macmillan).—Journal of the Bombay Natural History Society, No. 4 vol. vi. (Bombay).—Journal of the Institution of Electrical Engineers, No. 97, vol. xxi. (Spott).—Bulletin of the New York Mathematical Society, vol. 3, No. 7 (New York).—Physical Society of London, Proceedings, vol. xi. Part 3 (Taylor and Francis).—Proceedings of the Geologists' Association, vol. xii. Part 7 (Stanford).—Journal of the Royal Microscopical Society, April (Williams and Norgate).—A Manual of Orchidaceous Plants, Part 3 (Vetch).—Notes from the Leyden Museum, vol. xiv. Nos. 1 and 2 (Leyden, Brill).—American Journal of Mathematics, vol. xiv. No. 2 (Baltimore, Johns Hopkins).—Transactions of the Royal Society of Victoria, vol. ii. Part 2, 1891 (Melbourne).—Report of the Geological Survey of India, vol. xxv. Part 1 (Calcutta).

## CONTENTS.

PAGE

Theoretical Chemistry. By Prof. M. M. Pattison Muir	601
The Travels of a Painter of Flowers. By W. B. H. 602	
American Town Trees	603
Our Book Shelf:	
Briggs: "Synopsis of Non-Metallic Chemistry"	604
Whiteley: "Chemical Calculations"	604
Bonney: "The Year-book of Science"	604
"Handy Atlas of Modern Geography"	605
Letters to the Editor:—	
Aurora.—Geo. M. Seabrook; Arthur Marshall;	605
Arthur E. Brown	605
Pigments of Lepidoptera.—F. H. Perry Coste;	606
Prof. R. Meldola, F.R.S.	606
Eozoon.—Sir J. William Dawson, F.R.S.	606
The Theory of Solutions.—Prof. W. Ostwald	606
Physiological Action of Diminished Atmospheric Pressure.—F. R. Mallet	606
Sensitive Water Jets.—W. B. Croft	606
Double Orange.—Gerald B. Francis	607
On the Line Spectra of the Elements. By Prof. C. Runge	607
Aberrant Fossil Ungulates of South America. By R. L.	608
The Changefulness of Temperature as an Element of Climate. By H. F. B.	610
Forestry in America. By Prof. W. R. Fisher	611
Notes	612
Our Astronomical Column:	
Spectrum of Nova Aurigæ	616
Photographs of the Region of Nova Cygni	617
Winnecke's Comet	617
Personal Equations in Transit Observations	617
The Sirius System	617
The Ancient Civilization of Central America. (With Map.) By Alfred P. Maudslay	617
University and Educational Intelligence	622
Scientific Series	622
Societies and Academies	623
Books, Pamphlets, and Serials Received	624





Q  
1  
N2  
v.45  
cop.2

Nature

Physical &  
Applied Sci.  
Serials

PLEASE DO NOT REMOVE  
CARDS OR SLIPS FROM THIS POCKET

---

UNIVERSITY OF TORONTO LIBRARY

---

✓  
100/1

✓  
432 ~~442~~ A held

✓  
423/

463

99/502

