





12986



THE  
NATURE-STUDY  
REVIEW

---

Volume XIII, 1917

---

ANNA BOTSFORD COMSTOCK  
SECRETARY-EDITOR  
CORNELL UNIVERSITY

PUBLISHED BY  
THE COMSTOCK PUBLISHING CO.  
ITHACA, N. Y.

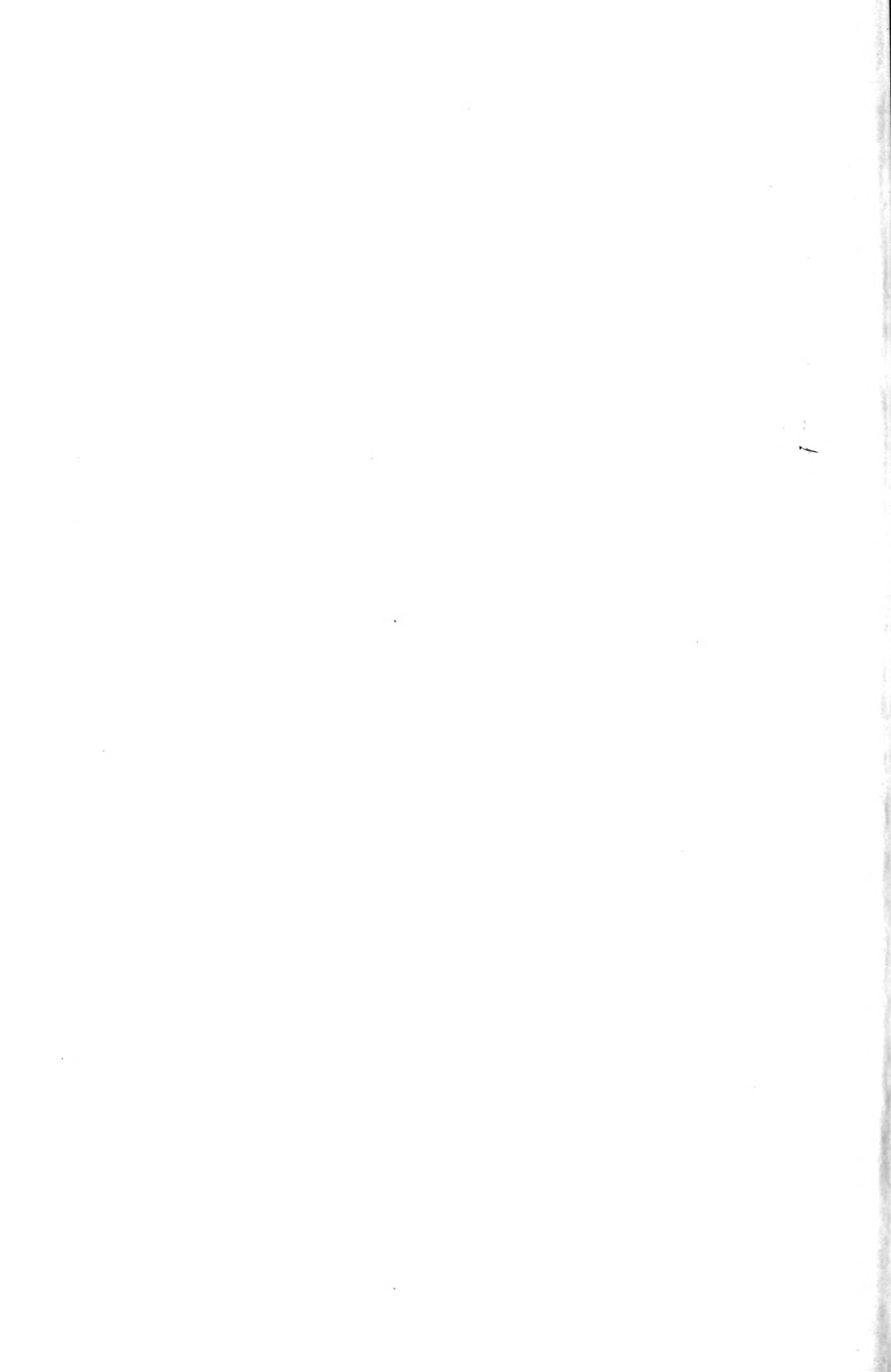

# NATURE-STUDY REVIEW

Devoted Primarily to all Scientific Studies  
of Nature in Elementary Schools

VOL. 13, No. 1

JANUARY, 1917

Whole No. 105

One year (nine issues) \$1.00

15c per copy

OFFICIAL ORGAN OF THE

AMERICAN NATURE  
STUDY SOCIETY

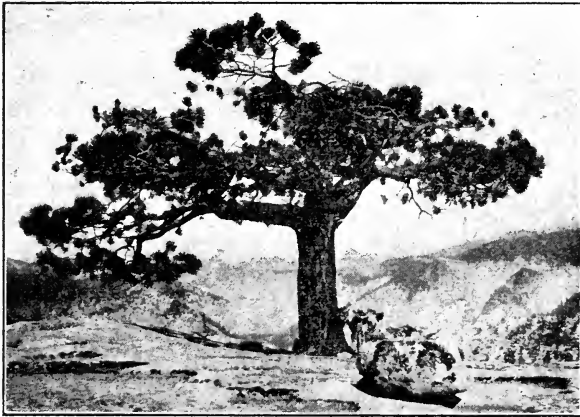

Happy New Year

# School Science and Mathematics Covers the World

**Here is the list of countries to  
which it goes each month**

Every State in the United States, every Province in Canada, Mexico, Cuba, Porto Rico, Brazil, Argentine, Chile, Peru, Ecuador. Every country in Europe including Turkey, Egypt, Liberia, Cape Colony, The Transvaal, Persia, Ceylon, India, China, Korea, Japan, Philippines, New Zealand, Australia, and Hawaii.

## Eight Departments:

Botany, Chemistry, Earth Science,  
Mathematics, Problems, Physics,  
Science, Questions and Zoology.

**Send in Your Subscription. \$2.00 per Year**

## SCHOOL SCIENCE AND MATHEMATICS

2059 East Seventy-Second Place

Chicago, Illinois

# BIRD - LORE

==== A BI-MONTHLY MAGAZINE ====

Edited by FRANK M. CHAPMAN

600 Pages

12 Colored Plates

200 Photographs

**PRICE ONE DOLLAR**

It will tell you how to study birds, how to form and conduct bird clubs, how to make nesting boxes, feeding stands and bird baths. You may consult its Advisory Council, take part in its bird censuses, and in short, become one of the great fraternity who finds in birds "the most eloquent expression of nature's beauty, joy and freedom."

We shall be glad to mail you a specimen copy on request.

---

## D. APPLETON & CO.

29 West 32d St. New York City

Kindly mention The Nature-Study Review when replying to advertisements

# THE NATURE-STUDY REVIEW

Vol. 13

JANUARY, 1917

No. 1



To the Nature-Teachers,  
Greeting:

The new year is before us, and the year is always young. It is our privilege to maintain interest in life, and to impart this interest to those whom we teach. I hope that the year will seem good to you.

L. H. BAILEY.

## SONG

CHARLES DE KAY

The winter woods, the  
 winter woods,  
 They bevel best with all  
 our moods,  
 With hardihood and  
 wild despair,  
 With tender love and  
 joyousness:  
 The crimes of cities they  
 redress,  
 And broken faiths re-  
 pair.

The winter woods, the  
 winter woods  
 Are better far than house  
 and goods,  
 Than food and raiment  
 better far,  
 Than gilded walls and  
 canopies:  
 They break but do not  
 stop the breeze,  
 And never hide a star.

## Agreement as to the Nature-Study Program

By JAMES G. NEEDHAM

Are we not agreed as to the fundamentals of a nature-study program? Professor Trafton raises this question in the October number of *THE NATURE-STUDY REVIEW*, and I want to go on record as believing that we are agreed quite as far as we should be.

The essentials of our agreement may be grouped under these three heads:

I. The nature-study course should be general—as general as the child's principal interests in the things and in the processes of nature.

II. It should be organized from the child's standpoint, proceeding from what he knows to what he can find out, and following the natural order of his developing aptitudes, putting wholes before parts, large things before small ones, attractive things before the less attractive.

III. It should fit the environment and be adapted to season, locality and conditions.

What certain critics have mistaken for disagreement among nature-study teachers is merely lack of uniformity, and is generally wholesome and desirable. Among the causes of this lack of uniformity are the following:

I. The infinity of nature. Her offerings are innumerable. No one can know or use them all, and with so much from which to choose not all teachers will choose the same things, though all may use what they choose to meet the same good ends.

II. The difference of locality, in accordance with which nature's offerings differ. Good nature-study teachers use things that are common and near at hand. They should not be expected to use the same things in the same manner all the way from Maine to California, any more than fishermen should be expected to do their fishing by the same methods.

III. Personal knowledge of nature possessed by the teacher. Each teacher should use what she can use best; what she knows best, likes best, and succeeds with best.

IV. Shifts of emphasis that grow out of increase to scientific knowledge. Such work with mosquitoes, with flies, or with bacteria as is often stressed now-a-days would not have been tolerated a generation ago, before the sanitary importance of these pests was known.

V. Control by the educational over-lords. Superintendents as a rule are sadly lacking in knowledge of nature, yet they have not hesitated to set metes and bounds to the nature-study work done in their schools, even by thoroughly competent teachers. Administration tends to uniformity—and to mediocrity.

It is neither surprising nor regrettable, therefore, that nature-study teachers are not all using the same things in the same way the country over. It is sufficient that they are working toward a common end, and that end, the education of the children in the love of nature and in acquaintance with and ability to use their own environment. When used to these ends real nature-study is never found wanting.

There are fashion-mongers in pedagogy as elsewhere; and they like to set us to cutting the cloth just a little different each season, and they like to get us to using new names for things. Thus they make quite a show of doing something original. Just now they are juggling with the "Junior High Schools" and with "general science." The content of general science courses, in so far as it has any value in primary education, is purely and solely nature-study renamed. And it must be so; for the primary educational need of human kind will ever be knowledge of mother nature, the source and sustenance of all human affairs—the great primal educator, who sets all our fundamental tasks for us, and offers all our permanent rewards. And at all stages of our progress, whatever we name our tasks, we shall only get on by the first hand study of nature, using the two old methods that have wrought achievement in the past—observation and experiment.

---

The report of the New York Meeting of the American Nature-Study Society will appear in the February issue.

The Index for Volume 12 of the REVIEW will also be mailed with the February issue.

## Nature-Study in Milwaukee and Its Vicinity

By FLORENCE J. KANE

Nature-study may be made one of the most profitable subjects taught in the common schools. However, teachers should not labor under an erroneous idea of what nature-study is. Reading about the duckbill-platypus of Australia or the ant-eater of South America or listening to the teacher's tale of the life story of the octopus or the crocodile may be highly entertaining natural history for a boy and may give him considerable erudition, but it can hardly be called nature-study. First of all, nature-study should be practical and suited to the environment in which the child lives. Hence a lesson on the common house fly, the clothes moth, or the cockroach—not from reading but from direct observation of the insects' life habits—may be made practical nature-study for the child, and if the lessons are conducted in a psychological way, may give him no little mental training. Nor need a teacher fear that the material for study that lies within the surroundings of the child's own home will ever be exhausted, however humble and limited in area that abode may be; for the living things of earth are like the stars of the heavens in this: that the more intensified study reveals but a greater infinitude. As Longfellow said of Nature and Agassiz:

"And whenever the way seemed long,  
Or his heart began to fail,  
She would sing a more wonderful song,  
Or tell a more marvelous tale."

I like the idea of gardening and tree planting for the child because from these useful activities may be derived innumerable lessons in seed testing, seed sprouting, seed planting, soil cultivation and drainage, plant cultivation, and the conservation of that animal life which is beneficial to man's existence.

When it is almost time for a child to buy his seeds in the spring, he will enjoy a lesson on seed testing. When he has buried his seeds in the soil, seed germination under a bell jar will be highly instructive and entertaining. He will be pleased with a lesson on the earthworm and the ant when he knows they are directly concerned in the fertilization, cultivation and drainage of his soil. He will regard the bee as his assistant in fruit production. The hideous, despised toad, the reptile-like salamander, the frog, the loathed garter snake—animals he has been reared to look upon



with aversion—will, under the wise instruction of his teacher, show their economic value; and the child will take steps toward their conservation rather than their destruction. My pupils were very much interested in a colony of earthworms that they had set up in a lamp chimney where they could observe their burrowing and also their feeding on dead carnation leaves. Thus they had a miniature exhibition of what the earthworms in the garden do in making passages for the rain to descend to the roots and in mixing humus and loam. The general ignorance of the value of the toad as an indispensable garden assistant is often quite surprising. I once asked a class of seventh and eighth grade Milwaukee boys to bring me what they thought a toad would eat. I received bits of roast beef, bread, cake, and candy. Not a child thought of an insect or a worm. The toad, of course, remained immovable on the presentation of the children's delicacies; but when I set before it a caterpillar and it snapped up the wriggling creature with quick intelligence, there was great surprise and excitement among the audience. I asked the same class if it was true that toads gave people warts. They firmly declared that it was, while several of them pointed out certain warts they had received from toads, stating the time and occasion of the transfer.

In connection with the garden work we should teach the little one how birds are of personal use to him both as insect and as seed eaters. Let him study preferably those birds that he is likely to meet in his yard, in the trees about his residence, on the margin of river and lake. He should be taught how to attract desirable birds to live about his home.

It has been my experience that a child is more interested in a garden of his own at his home than he is in a class garden on the school ground. Some of the rural schools are giving credit toward graduation to those children who do successful home planting and cultivating. This of course, requires inspection by the teacher. Perhaps teachers may imagine that their poorest pupils cannot find a place about their homes for this work; but it would not be difficult for such people to secure window boxes. Mr. Peaslee of the Milwaukee Public Museum saw and took a picture of one child's garden that was made in an old shoe.

If we look about our city streets to see how sadly Milwaukee trees are neglected,—some of them allowed to be overcome by disease, others mutilated by the work of ignorant trimmers—we

may realize how beneficial it would be to Milwaukee to give the young instruction in the care of trees. Were we to teach our children to thoroughly admire and respect a noble tree, to call it by name, to know how many years it has taken it to arrive at its beautiful maturity, to know something of the insect pests that infest it and the best methods of eradicating these pests, we might one day rear a generation of citizens whose legislation would provide Milwaukee with a chief forester and enough assistants to prevent the devastation of hundreds of our trees by the cottony-scale and the white-marked tussock moth. How Milwaukee people respect an old tree was shown last year when two noble elms on the corner of State and Twelfth Streets were felled for the accommodation of the streetcar company because the beautiful intricate lace-work of their branches interfered with the hideous trolley wires; and scarcely a protesting voice was raised against this outrage on two trees that had given a protecting shadow to Milwaukee pedestrians when the city was in its youth.

The education given in our common schools is supposed to provide the child of the masses with the rudiments of what he will need in his struggle for an existence. Yet the great agricultural United States has not, until quite recently, seen fit to introduce into its courses of study for elementary schools anything that will incline a child to agriculture. A city boy who is interested in the planting of trees, shrubs, vegetables, and flowers is learning practical lessons every day that are not only useful to him as a child but will lay the foundation for more extensive work along that line for the future whether his manhood is to be spent in urban or in rural districts. The majority of people have no use in after life for a large percentage of the arithmetic and the geography taught in the grades. Could not the time be better employed by giving the child something more practical and enjoyable? And why should a child not be directed toward horticulture or bee culture rather than toward some unenumerative city employment—a position as dry-goods clerk or the work of a pale-faced, emaciated bookkeeper? Even city people may successfully carry on some branches of farming, such as the raising of mushrooms, celery, or poultry.

I believe also that nature-study will give a student a good foundation for the biology and geology of the college, because he will have a broader understanding of plant and animal life and

will be more interested in plant and animal evolution and structure as a consequence of the preliminary nature training, while his little lessons in physiography will bear the same relation to his geology. Science has been making such great strides of advancement in recent years that the demand for scientifically trained men and women to fill a variety of positions is greater than it has ever been. The nature-study may lead some child toward the pursuit of a scientific education who might otherwise never realize he would have a liking for that kind of work.

In teaching nature in the Milwaukee public schools the teacher labors at a decided disadvantage under the meager and impractical course of study supplied her. The entire course consists of vegetables, flowers, trees, and birds. With the exception of birds, animal life has been entirely neglected. It would be more practical for a Milwaukee child to study about the horse or the toad than the cedar waxwing. A certain little fifth grade girl who had studied the cedar waxwing lamented because she had never beheld the exquisitely colored creature. Yet she probably never would see it in the heart of the city where she lived; for the bird is spasmodic in its flight, and its appearance can be depended upon at no certain time or place. It likes to frequent regions abounding in cherries and strawberries; consequently a little girl might have to wait a long time before seeing it in the busy streets of a large city. While a Milwaukee child is spending time on the sea gull or the night-hawk, a small citizen of Sturgeon Bay, a city surrounded by cherry orchards, might study the waxwing quite advantageously.

If a man could cast out from his life one of his greatest plagues—the destructive work of insects—with that ease and nonchalance that Milwaukee has eliminated insect study from its course, what a cheerful prospect life would present for the future! I argue that it would be far more profitable for a city child to be familiar with the habits of human and household insect pests than dwell at length on the phlox or petunia as he is supposed to do in the second and fourth grades respectively. It is not necessary for a child to spend a great amount of time on the structure of a great variety of flowers, because that sort of work can be more properly taken up in high schools and colleges. The elm-leaf beetle, the plant louse, and the garden slug are more vital problems for the city people than the structure of the geranium or the *poetulaca* work designated for the eighth and fifth grades respectively. No refer-

ence is made in the course of study to the different kinds of soils, rock formations or disintegrations, or the work of sand, pebbles, or streams. There are not enough suggestions for teaching given in the little book to enable teachers to get an idea how to approach this subject that is generally acknowledged to be poorly taught; nor is there a reference to show where approved reading matter or methods may be found.

I believe that some teachers who fail in the teaching of this subject do so because they do not have the object to be studied before the eyes of the child, and they tell or read him the nature story instead of allowing him the pleasure of discovery. I recently asked a Milwaukee child, who was supposed to study the squash in the fifth grade, what she knew about the plant and what the teacher and pupils had done with it. She had seen a squash and its seeds and had eaten squash at her own dinner table, and she told me with some pride that her teacher illustrated everything beautifully on the blackboard; but the child had never been induced to plant a squash and had never witnessed the wonderful sprouting of its seed which shows so nicely plant differentiation and adaptation. Then, too, a teacher often hesitates about undertaking the teaching of nature because she feels ignorant of the subject matter and imagines one must have a scientific education to do successful work. Though undoubtedly training in science is a distinct advantage, one cannot possibly be a specialist in all the branches she is required to teach in the common schools, and creditable work may be done by any teacher who is willing to make the preparation necessary for each individual lesson. Without this preparation she does not know what possibilities for the child lie in the subject she is to present.

A nature lesson should be conducted by the teacher's questions, directions, and suggestions of how to work, the teacher telling as little as possible, the child doing his assigned work with practically no help. He is thus kept alert in his observations of natural phenomena. His ability to eliminate unnecessary details and to abstract from his observations that which will be most useful to him in the interpretation of some new situation or condition increases with each lesson until he is often able to surprise his teacher with his thinking power. An interesting instance of this was shown me last week by my fourth grade pupils. I had written some questions on the board about crayfish among which were these:

Can a crayfish hear? If so, where are its ears?

Can a crayfish smell? If it can, find its nose.

I did not expect my pupils to answer either of these questions. I like to give them occasional ones that I know they cannot answer, just to set them to thinking. But to my surprise, several pupils insisted that the little white spots at the base of the antennules were its ears. I pondered for some time over the way in which they got the information. There was no book at their command, and I thought it hardly possible any one could have told them. I afterwards discovered that they had arrived at their conclusion in this way: It could hear; that was evident from its behavior. There were no ears in the place where ears were supposed to be. They had come upon the little white spots at the base of the antennules when they were studying the animal; and remembering a lesson they had had last fall on the grasshopper when on each front leg on each knee joint was found a roundish spot which proved to be an ear, they decided that if grasshoppers could have their ears on their knee joints, crayfish might have them at the base of their feelers. They could find nothing that looked like a nose; so they decided that the sense of smell lay in the antennæ by the way the animal used them when walking and when examining its food. They also brought their knowledge of ants' sense of smell to their assistance in the solution of this problem.

A question requiring a thoughtful answer may often be given incidentally without any great preparation on the part of the teacher. For example, in the spring the children come with pussy-willow twigs which I place in water so that the emergence of the blossoms from the furry coats may be seen. It is a great surprise to the children to learn that willows, elms, and maples have blossoms. The flowers, being comparatively inconspicuous, have escaped their observation. I ask them, "Which appears first on a plant in the spring—leaves or blossoms?" They answer *leaves*, of course, and reference is generally made to the apple tree. But we turn to our pussies in the window that are yellow with pollen when not a green leaf is in sight. Here is an apparent inconsistency; but they have learned by experience that there is no such thing as a freak in nature, that there is some reason for every deviation from the beaten path. I ask them to watch the blossoming of various trees and to let me know some day why the apple tree sends out its

leaves before its blossoms, and why the willows, the elms, and the maples blossom before the coming of their leaves.

Though the practical part of the lessons and the work in thought development should be given due prominence, the side of moral and esthetic training should not be neglected. A child should learn how unrelenting and uncompromising Nature is in her punishment of him who disobeys her laws, how she rewards him that heeds them. For example, when a child has once seen the inside working of *formica sanguinea*, a species of ants common in Milwaukee County that capture and enslave other ants—he will be forcibly impressed and ready to assimilate what the teacher has to say on the inevitable degeneracy of the mistress ants and the ascendancy of the slaves. This lesson may be associated with his history lessons on American slavery, and he will realize as never before how the abolition of the slave was necessary to save the white people of the south. When man disobeys the decree that he must earn his living by the sweat of his brow, he will one day find that Nature has meted out his punishment to him in his inefficiency. The association may be carried still further to the child's work in physiology where he learns how the unused part of his own body deteriorates; and thus he may be made to see how necessary it is for him to solve his problems, to do his work so that his brain and his body may develop to their greatest efficacy.

It has fallen to my lot to teach among the poor, people with homes usually devoid of artistic pictures, music, or literature, and my pupil's parents are often too ignorant or too busy with life's drudgery to give him any instruction that will lead to the formation of a beautiful thought or a noble ideal. Certainly his school should fill this breach for him, and if he is destined to become a factory laborer like his father, how much richer his life will be if, through his school literature, music, painting and nature-study, he feels a thrill of delight at the fleck of the tanager's feather or the melody of its song. What if he never hears the voice of Shumann-Heink? He may listen to the mellow contralto of the bluebird. His eyes may never feast upon the grandeur of the western mountains, but the majesty of the flight of the great blue heron ascending from Milwaukee River is his own. I should dislike having a pupil of mine grow into the adamantean condition of an old farmer I once knew who gave me a ride one fall day along a country road. Suddenly a woods burst upon my view—a woods aglow in its

beauty of autumnal opalescence. The farmer seemed busy in the contemplation of his wagon bed. I did not like to have him miss a sight so beautiful, and I called his attention to the scene before us; whereupon he looked up, gave a sort of grunt, and quickly fell to musing on his wagon bed again as if he had been loath to have his attention diverted by anything so trivial as an autumn woods. It was pitiful to see him living in the midst of so much beauty with eyes incapable of seeing it.

I would have my pupil appreciative of the wonders of nature—the harmony in the community life of ants, the wonderful evolution of the toad, the metamorphosis of a dragon-fly, the peculiar differentiations evolved by plants and animals to secure the best adaptation to environment; and thus he may learn to venerate the Power that makes each plant and animal, each stone and grain of sand fulfill its little destiny in the great scheme of our universe.

## Extracts from Bulletin of the Massachusetts Fish and Game Protective Association

### GAME CONDITIONS

Pheasants are less common than they have been and fewer are being killed this year. They are much shyer and do not flush as readily but run when disturbed. The bolder birds living along the roadsides have been killed and now the gunner must hunt to find the wilder and wiser ones that are hiding in the more remote and sheltered places. The severe winter killed many adult birds and the late, cold spring destroyed many eggs and young.

The Ruffed Grouse are to be found in fair numbers, especially in the western part of the State. There are not, however, as many as there were last year.

Bobwhite are reported to be fairly numerous on the Cape, in Plymouth County and in southern Bristol County. These splendid birds are practically extirpated throughout the central and western parts of the State. The five-year closed season in Essex County came none too soon and there is a growing demand among those interested in the conservation of our wild life that Bobwhite be afforded the protection of such a five-year reprieve throughout the State.

Deer are quite numerous, especially in the western counties. They are learning the necessity of avoiding man during the open season and after the first few days are difficult to approach.



FIG. 1. A typical swamp scene in the autumn.



## Botanizing in the Fall and Winter Months

By Dr. R. W. SHUFELDT

(Illustrated with photographs by the author)

As everyone knows who studies wild flowers afield, the collecting locality and the season are two very important factors to be taken into consideration. In most high northern latitudes the botanist finds but little to interest him, after the autumn days have surrendered, to the advance of all that winter brings with it. This is not the case, however, in the typically tropical regions, for there we find vegetation of all kinds flourishing throughout the year. Very well do I remember, when I lived in Cuba, in the suburbs of Havana, how the plant and tree growths astonished me; I saw orange trees in blossom, with dead-ripe oranges on the same tree. In the dense tropical jungle and forest there is a perpetual plant strife going on at all times throughout the entire year. Trees, great vines, hundreds of varieties of flowering plants struggle eternally with their neighbors to hold their ground, keep erect, and in many cases to maintain positions and attitudes whereby they may receive what sunlight comes to them.

In tropical forests I have seen trees where, when their fruit has ripened, it has fallen and lodged in one of the forks or crotches formed by limbs springing from either the main trunk, or from larger limbs. Such places often have a mass of decayed leaves or other rotten plant refuse in them, and here the ripened seeds of which I speak would take root, soon become young trees, and threaten the life of the parent tree. The roots struggle down to the ground, and with this added sustenance they soon become trees growing upon another tree, which latter begins to weaken under the burden it is called upon to support. Then along would come some parrot or monkey, and make a home in the parasitic tree. They carry nuts and other kinds of seeds there, and among them perhaps the seeds of some great vine. These in turn take root in some crotch or other, and the vine in time sends its roots down to mother earth. In a little while the vine spreads all over both trees, while a second vine, coming up from the ground, fills in all below as it creeps from limb to limb. The trees now die, rot, and fall over. This causes both vines to come down in a heap, and, the seeds of some more vigorous growth lodging upon them, the day comes when the vines, too, die as did the trees they strangled.

This may happen before the last growth gains a good hold upon the ground; and, as the vine rots and crumbles, it in turn falls over, to die or to grow up as some sort of distorted weakling, or a crooked support for still other growths.

All this goes on continually from one year's end to another, and man but rarely penetrates into such places; though thousands of creatures, from a jaguar to a humming-bird, not to say thousands of different kinds of insects, spiders, reptiles, and other forms, live and die in such wildernesses where, for the most part, the gloom of dense shadow reigns, and the light of day rarely enters.

In the United States we have no such tropical forests, and I have only seen them in Cuba and southern Mexico. Our tier of southern Gulf states support but subtropical forests, and in them the botanist meets with most interesting plant growths at all times of the year, as I can vouch for from my experiences in Florida, Alabama, Mississippi, Louisiana, and Texas. It is not to this belt, however, that I desire to invite attention, but to the strictly north temperate one that extends across the country to the Mississippi Valley, where the winters are never as severe as in the northern tier of states, or as mild as they are further southward. Northern Virginia and South Maryland lie directly in this belt, and it extends westward to the region I have mentioned above. Here a very severe winter may send the sap of trees and shrubs far down, and eliminate every green thing above ground; or, on the other hand, a mild winter may allow many plants—quite a number of plants—to thrive in sheltered places from November until spring comes again. As I write these lines in my Washington home, we will have the first of November in three days; but if one thinks that botanizing in the open is over and done with, one had better think again and come nearer the truth next time.

To be sure, much of the country resembles the scene I here present in Figure 1; but even in such places the botanist will meet with much to study and admire. All manner of pond growths have gone to seed, as have numerous other plants which do not depend on the presence of water during the summer months. Here one may study the manner of many grasses of going to seed,—also the cattails, pickerel weed, arum, and marsh mallow, with a host of other interesting growths.

As we pass to the fields and woods during these days in this region, it is truly surprising to note that some of the early summer



FIG. 2. A magnificent specimen of the common Poke-berry bush (*Phytolacca decandra*).



FIG. 3. A monarch butterfly resting upon blue boneset.

flowers are still in bloom—late fellows, that seem to take pride in exhibiting their *staying powers*. Next Wednesday, only three days off, it will be, as I say, the first of November; and yet one would be astonished to see what a bouquet of wild flowers one could gather within the radius of a mile or more from where I am sitting. Such a bunch would contain black-eyed Susans, summer daisies, joint weed, self-heal, lobelia, purple asters, golden-rod and not a few others. In some localities a poke-berrybush, five feet or more in height, may appear almost as fine as the one I here show in Figure 2, barring the loss of nearly all of its leaves.

It is delightful to live in a region where one can go into the fields during the early part of November and find blue boneset (*Eupatorium caelestinum*) in bloom in some protected corner of an old, overgrown pasture, where the eye may catch the gay lilac color of its dense corymb of flowers, as it peeps over the bunch of dry grasses which nearly hides its withering foliage below. Perhaps even at this season there may be a belated Monarch butterfly resting upon the flower; if so, my Figure 3 will give a fair idea of the combination, after the surrounding growth of autumn plants and grasses have been removed.

As we ramble through the woods; as we pass through the meadows and brakes, or tramp into the marshes and wet places during these fall days, we will soon appreciate the fact that one of the most fascinating, perhaps one of the most profitable things to study, are the various ways in which various plants go to seed. Such studies are not only of value to the nature student, but they are very materially so to the practical botanist, to the wild flower culturist, and to the *testers* of seeds, who work with the economic researcher in that line of general agriculture.

Recently I have made many fine negatives of wild flowers as they go to seed, and I intend to publish these in various avenues from time to time. The present article can touch but lightly upon this question owing to space limitations; but my aim will be largely met through the presentation of one good example chosen to demonstrate what I have in view. I have selected a beautiful example of the common Velvet Leaf, also called "Indian Mallow" and "American Jute," a plant that has escaped from cultivation and now grows wild. It is the *Abutilon avicennæ* of Gray, and I present here in Figure 4 a lovely picture of its seed pods, which, as any one will admit, are truly artistic-looking little structures. My nega-



FIG. 4. Seed pods of the Velvet Leaf (*Abutilon avicenna*).

tive gives them exactly natural size; but of a necessity they are here reproduced somewhat under that, though not very much so. Note the elegant little green caterpillar on the stem. This plant has very handsome, deep yellow flowers that may sometimes be seen quite late in the season—even as late as the end of October in the South. The leaves are of a velvety feel, hence its name.

## Leaves from a January Note Book

*Notes taken at a window commanding a bird-feeding station:*

Jan. 13.—The male Downy remarks “tsip” quite frequently. He and his wife were here together all the morning. The weather has a rather thawy feeling and there are flurries of snow. The sky is thick and gray-white to the horizon and the distant woods are brownish-gray. A cold color, even though there is red in it. The snow, while the pines hold very little of it, quite a difference in the snow storm of great soft flakes has just begun and many perfect crystals of this type are to be seen.

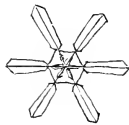

Jan 14.—“The snow that began in the gloaming” has heaped everything in sight with a silence deep and white. Even the telegraph wires were cables three inches in diameter, and on the limbs of the tree in front of the window the snow is heaped five inches high. In just a few places the wind has blown it off so that the tree looks as if it were decorated with wads of cotton wool. Under this heavy snowfall the pines are more weighted than the hemlocks. Harriet (the female hairy woodpecker), has just come with a “tsip-tsip” and has hunted out the suet under the snow. She tried to get it from above, failed, and then tried it from below successfully. The little Madam (the female downy) came afterwards and did the same, then came the chickadees and had their breakfast, bottom side up.

Jan 15.—It is a cold windy morning with now and then a cold flurry of hard snow. Madam Downy has been hanging on the leeward side of the tree, drawn up into a little bunch and her feathers fluffed out. Occasionally she cleaned a feather or scratched herself with her beak quite at ease. Heard a chickadee singing his little high note, “teedle-chk-teeledle.” It is a sort of chickadee yodle.

Jan 16.—Mr. Downy was eating suet to-day and drove his beak into it in such a manner that he got as much on the outside as he did on the inside, and this disturbed him. He thrust out his long tongue and drew what he could inside, and then tried to rub his beak clean on a twig, but not till he began to pick a hole in the bark of the twig did he succeed in getting his beak clean. Though the wind has blown quite severely the snow is not yet all dislodged from the pines.

Jan 17.—One great branch of scarlet oak has retained most of its russet leaves. It makes a brown spot in the white and gray landscape. I discovered to-day that Sir Hairy has his red cap parted with a black line. As he sits eating his suet, the wind blows up his feathers and I can see how long and soft and warm they are. A woodpecker sitting on a limb is a squat looking creature.



Jan. 19.—It was 22 below zero last night and I look at the world through a beauteous lace curtain of frost all worked in one pattern. I spoil the pattern with alcohol to make a peep-hole and am rewarded by seeing a blue jay eating suet in front of me. The sun glinting on the metallic blue of his topknot, his wing primaries, and his tail make him a beautiful object. That tail is a wonderful one, it seems to me. He drives his beak into the suet like a woodpecker, and though he hammers hard, his beak goes in just far enough.

Jan. 20.—The first thing I saw was the blue jay eating suet. I had to smile to see him pry it up, he acts as if he were chopping wood. He stands on top of it, stretches back on his toes, and brings his head and beak down hard and consecutively until he loosens a piece.

Jan. 21.—The blue jay is a great bully and has bad manners. He will not let Mrs. Blue Jay eat until he is full to bursting, and both of them drive away the little birds. The blue jay has heaven on his wings and hell in his disposition.

Jan. 23.—Some winter days are mighty disagreeable and this is one. We had sleet this morning and fine snow now that has a mind to change to rain. The whole sky and earth are snowy;



even the birds seem discouraged and the chickadees fluff up their feathers and do not sing a note.

Jan. 25.—Such a thick window that I can not see off a space it is soon covered with a frost layer which forms a spec- outside through exquisite



frost curtain on my double through it! When I clean covered again with a frost trum and I see the world rainbow colors.

Afternoon.—The sunshine is warmer and brighter and the nut-hatches call in polysyllables instead of monosyllables.

Jan. 26 —A cold day full of snow flurries and rather dreary. I think the blue jays have estranged me more or less from the other birds. They are like some people I have met—the more they are with you, the more other folks aren't.

Jan. 30.—It has been warmer today though still wintry, but the nuthatches think spring has come. They repeat their notes over and over, and one, probably the male, struts on the tree trunk, his tail spread like a little turkey cock, showing his white feathers. The chickadees sing "phœbe" too, and give their singing yodle.

Jan. 31.—Another cold wave has been billowing toward us all day, yet I heard the chickadees sing "phœbe" and yodle too, and we heard a Hairy drum and saw him at it. He is surely crowding the season.

### THE FEBRUARY HUSH

Snow o'er the darkening moorlands;  
Flakes fill the quiet air;  
Drifts in the forest hollows  
And a soft mask everywhere.

The nearest twig on the pine tree  
Looks blue through the whitening sky,  
And the clinging beech-leaves rustle  
Though never a wind goes by

But there's red on the wild rose berries  
And red in the lovely glow  
On the cheeks of the child beside me  
That once were pale as snow.

—*Thomas Wentworth Higginson.*

## The Diplomacy of the Good Teacher

JOHN WALTON SPENCER

A bit of sage advice from the unpublished MS. of "Uncle John"

In some respects children and bicycles have the same characteristics. Keep them moving and they are all right; check them and they wobble; stop them and they fall down. If you would do a kindness to a child, keep it busy. Blessed be the name of the mother who invented the rattle box. It gives the baby its first employment and happy moments.

The best helping hand you can give any and every child is Occupation and Appreciation: two simple things but to be effective, they must be given in a simple way—in a way which the child likes and not in a way which you think the child ought to like. It has as much right to its own way as you have to yours. A child can be led to find as much pleasure in an occupation with utilitarian ends as in one of thrashing the air. When small they never tire of playing with the sand. Good garden soil is just as acceptable. With the soil give some quick germinating seed. Then join with the youngster in the surprise and happiness of having given birth to a plant. No matter if the plant does not reach maturity, you have helped to make the first step in plant growth a pleasure and with it will come the desire to try again. Let the child adopt largely its own methods while you see that the course lies in the right direction. Do not discourage him with a lot of don'ts. Government by the negative is the method of the superficial and the lazy.

Once upon a time there was a fond mother who no doubt had the best interests of her child at heart but she had the "don't method," thoroughly in her nature. From the child's earliest recollection, he had heard but little else than "Johnny mustn't touch it." When the little fellow first went to school, the teacher said, "Now my little man, can you tell me your name?" The child, embarrassed by the newness of the scenes about him was slow to answer and the teacher repeated the inquiry. Still no answer. So the inquiry was given a variation. "Tell me what your mamma calls you." "Johnny mustn't touch it," came the murmured reply. I leave the question to you mothers and you teachers if Johnnie would not have been happier and had greater development if he had been provided with a lot of things to do than to have suffered

deprivation and been made to look prim. Though early results may be somewhat slattern, praise the effort which produced them and the child will be encouraged to try again. Remember the child's first footsteps. You were proud of the attempt and encouraged frequent repetition until at last the firm and confident step was acquired.

After providing occupation and stimulation by your approach, next incite wonder. Nothing can be more true than, "Knowledge begins with Wonder." By wonder, I mean a keen, active interest. You then have a hungry mind and a hungry mind is easily fed with information that is fully digested. Children and a comparatively large number of grown people have no relish for acquiring facts for some future use. They do not care to put knowledge into cold storage in the expectation of some coming time when it may be handy to have. If you have some mental wares you wish them to take off your hands, create a problem where those people can use your facts and your goods will be in demand.

I lately read an account of an American shoe merchant or manufacturer who wrote our Consul in a tropical town to know if there were many shoe stores in the town where he represented American interest. The Consul wrote back "Not a blessed shoe store in the whole town." He omitted to add that the natives had been bare-foot since a thousand years before Columbus discovered this America.

The enterprising Yankee sent a large consignment and an agent to dispose of them. The agent, on his arrival, was not long in seeing that the reason no shoes were sold was because the population did not feel the need of them. The agent, instead of shipping the stock back from whence it came, sent a cablegram ordering a hundred bales of cockleburs to be shipped by the next steamer. On arrival, those cockleburs were clandestinely scattered in places where the bare feet trod the most, with the result that the burrs sown not only tortured the pedestrians but grew a crop to continue the misery. Then for the first time, the natives felt the need of shoes and the Yankee established a fine trade. A desire for knowledge can be created after the same method. In these three things, occupation, sympathy and wonder, you have the development of learning by doing.

## The Old Pine Tree's Story

By ANNA BOTSFORD COMSTOCK

A suggestion as to a method of teaching history in connection with the life of a tree.

I am so old that I have forgotten the number of my years, but I was a middle aged tree before I ever saw a white man. I remember when I was one of twin seeds under a scale of a cone on my mother tree which stood yonder on the hill. One night a terrible wind blew down the lake and tore me from my protecting cone; but I had a little wing of my own and I went whirling around in great glee and finally settled to the ground under an old oak that stood over yonder. My bed was of leaves and very thick, and though I was safe and cosy, I feared I could never send my rootlet down to the earth through those dead leaves. And there I waited and wondered a whole year until one day a black bear came there hunting acorns. He scratched away the leaves with his great paws and though his visit was rather hard on the

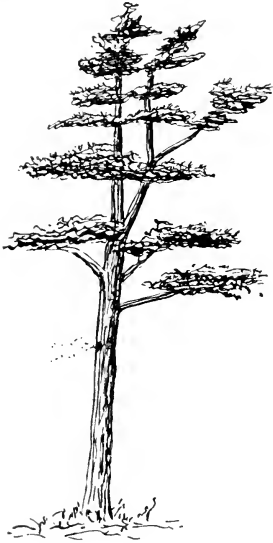

acorns, to me he was very kind for he threw me down next to the bare earth and pressed me down with great flat feet. So when spring came I nestled into the warm soil and put a little root down so far as I could push it, and then I pushed my head up with my seed cap still on. But I wriggled and shook it off and soon stood up with my tassel of needles free and with a little bud in the center that would reach up into the world.

Those first years were full of difficulties. There were around me many other plants that grew faster than I and spread their leaves above me and stole my sunlight. But I was a patient little tree and waited, and when they died with the first frosts of autumn I had all the light to myself and made the most of it. I stretched out my rootlets as far as possible and next year I was not so crowded. Later the great trees tried to crowd me out and shade me down but I would not give up. Once when I was quite young, some red men built a camp fire close to me and if the wind had not

been my friend that day and carried the flame off away from me, I should have been crippled for life. When I was quite tall, a beetle killed my leader as you call my topmost tip. At once two of the branches of my upper whorl tried to take the place of my dead leader; if one only had succeeded I should have been a straight and single shafted tree; but both those branches were so ambitious that neither would give up; so I was obliged to grow two tops instead of one. Finally, after many years I got my head above the trees that lose their leaves in winter and then I was all right.

I wish I could tell you the things I saw here in those days when all was forest except that ledge over there. The red men often passed here carrying their canoes for fishing excursions on the lake. And sometimes they had races there that were as exciting as those the crews row to-day but the trees were the only folk that crowded the shores to see them. The deer and the moose passed near me on their way to their feeding grounds up the marshy inlet valley, where the beaver builded. When there was a strong branch where you see that lower broken stub on my side, it was a favorite resting place for a great panther; there she would lie hidden until a deer passed below; then would she hurl herself upon it with such force that the creature never knew what killed it. Then she would drag her quarry to that little ravine and call her young ones from their den and they would feast together. The den was under the upturned roots of a fallen oak over there where that building now stands and it was kept very clean with no bones near it to attract the wolves that used to hunt there in packs at night with their noses to the ground like your dogs.

The red men often held their feasts on this hill. Here they made offerings to He-no, the thunderer, and to Ga-oh the spirit of the winds. Many times when I see the games played by the boys now I think of the games played here before a white man ever set foot on this hill. One of these games was snow-snake that was played over beyond the ledge; the snake was a hickory sapling as long as a tall man and polished with wax. The Indian youth took one end of it with his thumb and fingers and running a certain distance, threw it down a track made by drawing a small log straight over the snow. There was one boy here then who could shoot a snake twelve hundred feet, which is farther than any boy here now can throw a ball. But he was old and died before the white man came. When the white man came, all changed. He was a foe to the

red man, the deer, the panther, the wolves, and the forest; most of all was he an enemy of the pines. I can see now over in yonder field a row of the naked roots of my ancestors which man dragged from the ground to fence his little fields; they are still strong and undecayed though the rains of a hundred years have whitened them. Look at those great bleaching roots and see the foundations on which the pine trees build!

I am aged now, and mayhap soon this spot where I have stood for more than two hundred years shall know me no more. But I am not sad or lonely. Listen, I will tell you a secret: My old heart is kept sweet and warm by the bees that have found there an abiding place. My branches which have ever bowed in adoration before the wind-god Ga-oh are stiff now and must break before his majestic sway. But Ga-oh is the friend of the old pine as well as the companion of his strength and he will soon lay me on the dear earth whence I came.

---

“The speckled sky is dim with snow  
The light flakes falter and fall slow;  
Athwart the hill-top, rapt and pale,  
Silently drops a silvery veil;  
The far-off mountains misty form  
Is entering now a tent of storm;  
And all the valley is shut in  
By flickering curtains gray and thin.  
But cheerily the chickadee  
Singeth to me on fence and tree;  
The snow sails round him, as he sings,  
White as the down on angel’s wings.”

—*J. T. Trowbridge.*

# The Lombardy Poplar

A Kindergarten Story

By MARGERY B. LOUGHRAN

TIME—SPRING

*Introduction*



How wide-awake you are this morning, children! Come with me and visit a tree that is just waking up from its long sleep. Did you know that some of our trees sleep all winter? I know a tree that is just stretching and trying very hard to wake up just as you do in the morning. Come and let us listen to what it has to say to us.

Here is our friend a Lombardy Poplar. See how tall and straight, just like a soldier. Let me see you all standing straight and tall just like this Lombardy Poplar. We may call this our soldier tree because it stands so straight and tall.

I think the tree is talking in its sleep for it says: "Do you think I am dead because you see no leaves? I am only asleep; just look for my pointed buds! There are my leaves all folded away and

ready to come out when the days are warm." Children! shall we come out again another day and see the leaves when they come out?

Look at the branches of this tree. Let us all show by our arms how these branches grow up—pointing to the sky. Listen to my story that tells why the branches of the Poplar always point upward.

Once an old man took the bag of gold from the end of the rainbow and came into the deep woods. All the trees were as asleep and he quietly stepped from tree to tree, so as not to make a bit of noise. He saw no one, and as he thought he heard a sound of a footstep, he pushed the bag of gold far out of sight among the thick branches of the poplar tree. Then he hurried out of the wood as rapidly as he could.

The next day, the tree awoke and heard a cry ring through the wood. It was Iris, the goddess of rainbow. "The bag of gold at the foot of the rainbow has been stolen," she said. "Who knows anything about it?" The trees all shook their heads for they would not be so mean as to steal the bag of gold from beautiful Iris.

Away flew Iris to tell Father Jupiter who was very angry.

"We will find the gold, my daughter," said he. "Who knows the hiding place of the bag of gold?" he thundered.

"Not I," said the maple and all the trees at the same time.

"Lift up your branches to show you speak the truth," said Jupiter.

What do you suppose happened? (Opportunity given for children to tell). No one was more surprised than the Poplar tree, who trembled and shook from head to foot. Soon the Poplar tree spoke and said very solemnly.

"Never again shall my branches shelter stolen goods for others. My branches shall forever point to heaven to show truthfulness. This happened a long time ago, but the branches always point upward as you have seen them to-day.

The class all take one parting look at the sleeping soldier tree. Promise to find other Lombardy Poplar in the neighborhood and plan to visit this tree again to see its leaves and flowers.



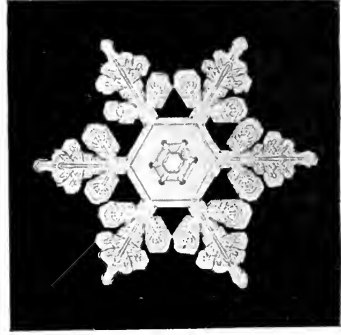
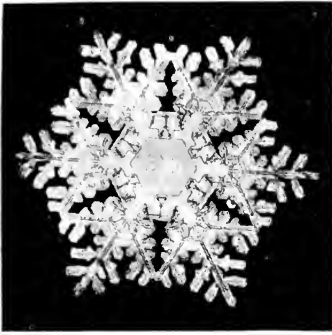

## January Nature-Study

ANNA BOTFORD COMSTOCK

“There isn’t any nature-study in January, there is just coasting and skating,” asserted a small boy friend of mine stoutly; and the teacher who has to give a nature-study lesson every day during this midwinter month will be constrained to agree with him. It is a pity that the significance of January’s reign in the natural world should be fitted only for grown-up comprehension. However, there are some topics in nature-study that belong to winter, suited for even the youngest children.

### SECOND GRADE

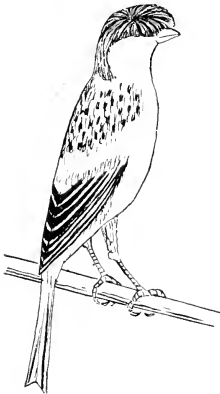

*The Canary.*—It is quite possible in most places for the teacher to borrow a canary and keep it in the schoolroom for a few days; or she may take her pupils to some home and visit a canary, and through the study of this long-suffering little cage bird, the children may come to understand the nature of the birds and their adaptations for life in the fields.\* The obs. 1, 2, 3, p. 51 will serve for the first lesson. These questions should be asked and a few days given for answering them. Obs. 4 is sufficient for one lesson if the bird has variegated colors. Obs. 5, 6, 7,

8, 9 suggest another lesson which will cover the food habits of the bird. Obs. 10, 11, 12 suggest a lesson on its interesting ways. Especial attention should be given to the different

\*The references are to *The Handbook of Nature-Study*.

notes of the bird, for the canary gives vocal expression to several emotions which we may understand. On p. 50 may be found a short account of the habits of this bird on its native islands; a more complete story is given in the *Pet Book*, p. 138.



*The Guinea Pig.*—This little cousin of the rabbit is a long way from being any kind of a pig, nor does it come from Guinea, but it and all its relatives flourish in South America. It would be better

if we could learn to call it by its real name, "cavy." The ancestors of our common pet are supposed to have been domesticated in ancient times by the Incas of Peru, since mummies of cavy are to be found in the cemeteries. Cavy were esteemed highly as food by various tribes of South American Indians.

The guinea pig is a stout, compact little creature with short, rounded ears and no tail; its legs are short compared with its body; the front feet have four toes and the hind feet three; the toes are armed with rather stubby nails; although the cavy is a true rodent it has short incisors, and the back teeth have crosswise ridges. The language of the guinea pig is not very extensive, consisting of squeaks and grunts. In a wild state the cavy are not truly diurnal in habits, although they are partly so. They make their homes in burrows or in crevices in rocks. They are vegetable feeders, and eat almost any kind of succulent food. In their native country, where it is never cold enough to freeze, they have green food all the year round. We feed them on grass, lettuce, apples, and especially upon carrots. They are also fond of rolled oats. Although they do not drink often, when fed upon vegetables, we always keep them supplied with water.

Guinea pig babies are very precocious. They are fully clothed and have their eyes open from the first, and are able to take care of themselves if necessary when only a day or two old. The best known varieties of this pet are as follows: The English, which has a short smooth coat, like the original wild cavy, and with varying colors. The Abyssinian, which has a rough coat, arranged in cowlicks of rosettes. The Angora, which has a smooth coat of long, soft hair, and occurs in many colors and patterns. The Peruvian has the long hair of the Angora, and the rosettes of the Abyssinian, and is a most frowsy little creature. While all these varieties may

have several colors, there are those of one color which are called self-colored.

A lesson on the guinea pig should include the following points: What does it eat? What does it like best of all? Does it drink often? How do we make a home for our pet guinea pig? Where and how do their wild relatives make homes for themselves? Are its legs long to fit it for running; are its hind legs strong to fit it for leaping? How many toes has it on its front feet and on its hind feet? Describe the toe nails. Are its ears movable? What colors in the eyes? Observe the teeth. Are they fitted for gnawing like those of the rabbit? Has it "whiskers" to feel with? Where is its tail? Describe its fur, whether fine, coarse, long or short, or in rosettes. Is it for warmth or ornament? In what position does it sleep? How does it play; how does it show anger or pleasure? Describe its voice; what does it say? How does it keep itself clean? How does it care for its young?

*The Cockroach*—This slippery little haunter of crevices has some interesting qualities even if it is a pest. In order that grown-up people be competent to deal with a pest, it is necessary that they know all about it, and this knowledge is gained more easily and thoroughly in childhood. A cockroach should be placed in a vial with a bit of bread and safely corked in, and then it may be passed around for observation. The questions in the lesson on p. 379 are sufficient for two lessons. Obs. 6 on how a cockroach cleans itself is enough for one lesson and should point a moral; for this insect dwells in places which are far from clean, but with its polished coat and habits of scrubbing itself, it keeps clean and lives long. No mention of how to get rid of this pest need be made, since the poisons used for destroying it should be applied only by adults.

*A Chippy's Nest*.—Any nest will do, but the chippy's is usually nearest at hand and easiest to get. The observations should be as follows: What bird built it? What for? Do the little birds come back to the nest after they once leave it? (This question is quite important to emphasize the fact that young birds do not return to the nest.) Of what material is the outside, the inside? Why is the lining so soft? How is the nest supported? For outline of study of chippy's nest, see p. 89. On p. 88 is material for a story to supplement this lesson.

*A Cocoon*—Any cocoon with a pupa in it will do, but that of the *Cecropia* is best, since it is largest. ¶ This lesson is for the purpose

of teaching how the cocoon protects the insect from weather and enemies. Cut open cocoon and use obs. 1-5, p. 334.

#### THIRD GRADE

*The Mouse.*—I hope that no teacher will scream or climb upon a chair when she sees this topic suggested for a nature-study lesson. A mouse, confined in a glass jar, (see "Method," p. 228) is one of the most interesting subjects for nature-study that I know; it can be kept captive for a month and studied at recess or at any convenient time. Mice are thirsty and must be given fresh water every day, and a shelter of strips of paper should be put in to afford the captive a place to hide and make it comfortable. A mouse is a very clever animal and has many cunning ways, the watching of which soon removes the ridiculous fear which the idea of a mouse inspires in some people.

Each of the Obs. 1-3, p. 228 is enough for a lesson. Obs. 4, 5, 6 constitute another lesson. Obs. 7, 8, 9 suggest respectively a story to be told by the teacher to make the lesson interesting.

*The Wolf*—Winter is just the season for reading about wolves; and an understanding of the habits of this animal is necessary before undertaking the study of a dog. Kipling's Mowgli stories and Thomson Seton's "Lobo" "Tito," "Bad Lands Billy," and the "Winnipeg Wolf" all give fascinating accounts of the wolf and its habits. See p. 255. The topics in the last paragraph on p. 256 should be used as subjects for oral questioning or for written accounts.

*The Goldfish*—It is a pity that these golden idlers in a school aquarium are so seldom used to illustrate the adaptations of a fish for life in the water. One goldfish will afford enough material for the nature-study lessons for a week.

For the first lesson, use Obs. 2, 3, 4, p. 152; Obs. 5, 6 for the second; 7, 8 for the third; 9, 10 for the fourth; 11, 12 for the fifth; 13-16 for the sixth lessons. Obs. 17, 18 suggest topics for a story. See *Pet Book*, p. 226.

*The Sun*—January is an excellent season for beginning the study of the sun, for it rises after we awaken in the morning, and sets long before we go to sleep. Of course a serious study of the sun is too advanced for third grade, but certain observations can be made and stories told, so that the children may know that it is a great blazing star. See p. 905-6. Observations on the time of the

rising and setting of the sun should be made once a week and the curved shadow of the shadow stick should be examined once a week to show what has happened: First that the sun may rise thirteen minutes earlier in the morning on the 31st than on the 1st of January, and that it may set thirty-three minutes later, the gain in the length of day being mostly in the afternoon. The almanac should be used to correct the children's observations. The shadow-stick will show that the sun is higher at noon—each successive week.

*The Polar Constellations*—The dark comes so early in January that the stars may be studied by even the young children before

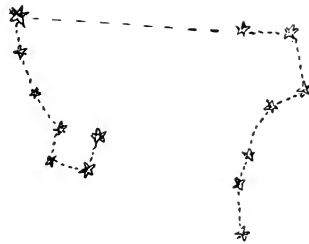

bedtime. The first constellation to be taught should be the Big Dipper, and how to find the Pole Star by means of its pointers. The next constellation to be learned is Cassiopeia's Chair, and the next is the Little Dipper. For third grade it is sufficient to teach that a constellation means a group of stars that appear to us to be near to each other or to form a figure of some sort; and that the polar constellations are those which in our latitude never set but may always be seen above the horizon all night on any clear night of the year. See p. 889.

#### FOURTH GRADE

*The Screech Owl*—This interesting little night flier manages to eke out an existence in winter by hunting field mice and other small creatures. It sometimes gathers in a feast through finding a sparrow roost. It is very desirable that the pupils observe a live

owl, whether in the school room or in the zoological gardens. However, screech owls are not always so accommodating as to be

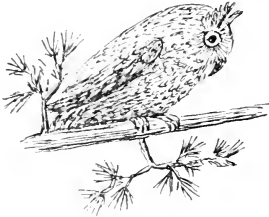

present for nature-study lessons, and the habits of this bird are so interesting and important, that we may be allowed to use a picture as a peg on which to hang a lesson. This is even one of those rare occasions where a stuffed specimen may be used without causing a scandal in the nature-study ranks. For a lesson

with the live bird, or without it, for that matter, the Obs. 1-11, p. 106, each affords a topic for a short written lesson.

*The Pig.*—This most clever and most misunderstood of all the domestic animals offers a fine opportunity for the observations and deductions which constitute the right sort of nature-study lesson. The pig is an animal fitted to roam at large in woods and forests, especially in the neighborhood of streams where it finds ample food in acorns, roots, etc., and fights its battles with its own strong weapons, and protects itself from stinging insects by wallowing in the mud, and in general leads a successful life. On p. 303-306 information is given which will enable the teacher to present the lesson in an interesting manner. Obs. 1, p. 307 is enough for one lesson when written. Obs. 2, 3, 4, 5, 7 form another lesson. Obs. 6 another, and Obs. 8, 9, 10, 11 another. Obs. 12 suggests topics for more serious essays.

*The Pines.*—We have in America several common native pines and several that are generally planted in parks and grounds that have been introduced from Europe. On p. 112 of the *Tree Note Book* is given the table for determining these pines by the number and length of the needles and sheaths. For this lesson, choose a pine near the schoolhouse so that it may be observed for several months. Obs. 1, 2, 3, p. 795 constitute an observation lesson out of doors, while Obs. 4 includes a sketch and perhaps a comparison with the leaves of some other species, and Obs. 5 and 6 constitute two lessons that may be completed in the schoolroom with the specimens brought in by the pupils and the results written. Information for Obs. 8 and 9 should be obtained through reading reference books. The age of the tree should be ascertained if possible, and if it is an old tree, its life should be correlated with history. See "The Old Pine Tree's Story" in this issue.

*Orion*—This beautiful constellation adds a splendor to the sky in winter evenings that may not be equalled at any other season.



At eight o'clock in early January it fills the southeastern quarter of the sky. It is the constellation that most people know because of the three stars that ornament the belt of Orion, the mythical hunter. However, the constellation contains two magnificent stars, and learning to know them adds much interest to the study of it. Old Betelgeuse whose fires are red and therefore waning, is the most interesting of them all because, in our fancy we can imagine its fires extinguished, and

it growing cold,—great dark, dead star. On the other hand, Rigel is a young star as we can tell by its white and blue light and has just started on its career. A diagram of Orion, as here given, should be placed upon the board and left there for several days. The questions in the lesson on p. 896 should be asked a few at a time, and the answers given the next day.

*The Building of Bird Houses*—This is an excellent occupation for January, since the bird houses when completed may be put up before our song birds return. In making a bird house, the pupil should have in mind definitely the bird for which it is meant. Size of the hole and depth of the cavity below the hole and behind the hole are all of the utmost importance. Directions for making these nests may be had by applying to the Audubon Society. When a boy makes a nest box, he should also put it up. This will lead him to study the natural haunts of the bird and to learn the height above the ground at which the bird usually nests.

*The Sumac Winter Banquet*—Sumac "bobs" spread a banquet for birds all winter and it would be well to encourage the pupils to note any birds that are eating them. They also harbor many insects, and an interesting lesson may be had in a nature's winter quarters by taking to pieces one of the "bobs" on a newspaper and noting all the living creatures that may have been hidden in it. Use Obs. 4, 5, p. 809 for a lesson on the sumac fruit.



An ideal turkey country. They will go a long way to roost in trees growing in water



## The Grandest Bird of the American Continent

*The Wild Turkey and its Hunting.* By A. McIlhenny. Pp. xi-245.  
1914. Doubleday Page and Co., \$2.50.

The word "turkey" and the month of November have a wonderful power to arouse many kinds of pleasant memories. Perhaps most of these thoughts cluster about bountiful repasts, but there are other aspects of much interest which appeal to the student of natural history. The extermination of the wild turkey from vast areas teaches a lesson of warning, and the present volume gives valuable information as to how this condition may to some degree be remedied. This very interestingly written volume is the only book devoted solely to this bird, and has all the internal evidence of having been written by one who knows. A book of this character has a permanent value, and will be of much value and interest to those who breed turkeys.

This book is not, as one might hastily assume from its title, merely the adventures of a hunter in quest of game, but is a careful summary of prolonged field studies of the habits of this bird by two enlightened sportsmen, Mr. C. L. Jordan and the author. The superb illustrations, examples of which are here given, are also the work of Mr. Jordan; Dr. R. W. Shufeldt has prepared the chapters on the supposed fossil remains of turkeys, the structural features of the various wild races, and summarizes the characteristics of the eggs and skeleton. The large amount of valuable materials on the natural history of this bird is indicated by the discussion of such subjects as: the storage of fat on mature gobblers, shrewdness of the bird, social relations, nesting, young birds, association of the sexes, roosting, enemies, food, and methods of calling turkeys. The brief chapters on hunting, camera hunting, and cooking the turkey indicate the comprehensive character of the volume. As examples of subjects of special interest mention should be made of the fact that during the gobbling season the males take but little food and live largely upon the fat stored on the breast, and during floods the turkeys on the bottoms live for weeks in the trees feeding upon buds and fruits. The calling notes and means of imitating them are discussed very fully and may be looked upon as an extensive experimental field study of the voice of this bird. The book contains so much interesting material that it should have been made readily accessible by a good index, which

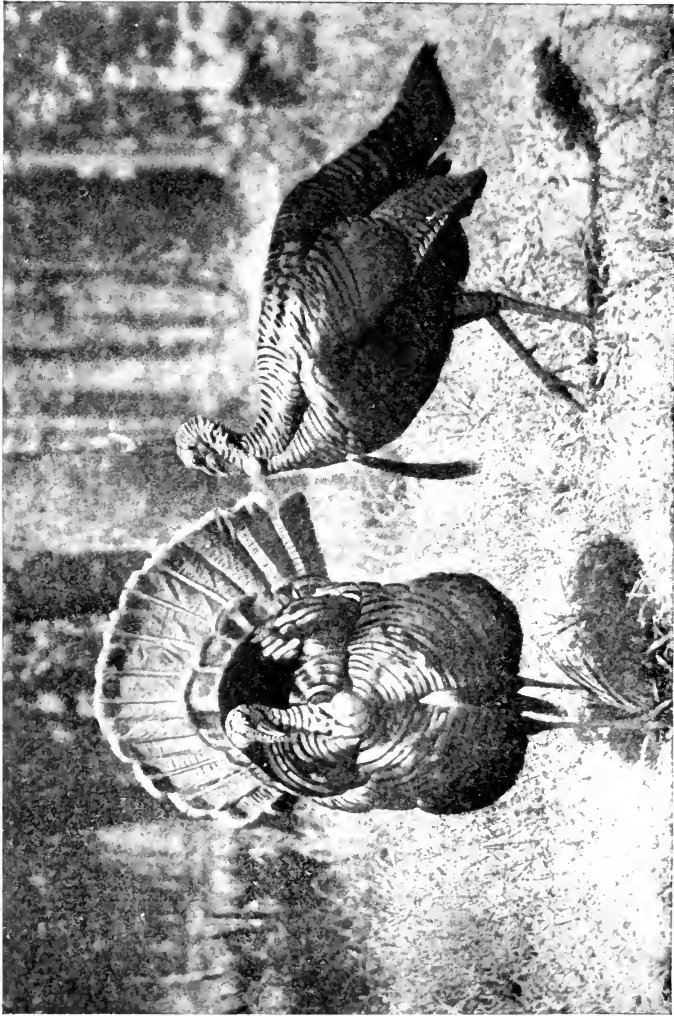

The beginning of the strut. These gobblers are strutting before the camera, hidden by brush in an endeavor to attract the hen turkey whose love call the camera man is imitating with his "caller."

is lacking. Alert teachers will not neglect the opportunity of utilizing their pupils or students interest in this bird in order to increase their knowledge of its natural history. It is of interest to recall that the author of this book, in association with Mr. C. A. Ward, founded the famous Ward-McIlhenny Bird Preserve which they presented to the State of Louisiana. This 13,000 acre sanctuary is one of the finest preserves ever devoted to wild life. Let us hope that the founders will some day give us a volume on the natural history of this preserve.

CHAS. C. ADAMS.

---

A NEW REPORT ON BIRD ENEMIES

The Massachusetts State Board of Agriculture has published a very interesting bulletin on "The Natural Enemies of Birds." by E. H. Forbush, State Ornithologist. In this book Mr. Forbush has compiled a great amount of valuable material and the conclusions drawn by him will serve as his professional advice to those interested in the welfare of birds. The pith of his message is that we should exercise the greatest care before condemning any creature as injurious. His demonstration of the complex economic relations in nature is extremely interesting to the nature lover. Copies of this bulletin may be obtained from the State Board of Agriculture, Room 136, State House. It is listed as "Economic Biology, Bulletin No. 3, The Natural Enemies of Birds."

---

The snow-covered hills are bathed in warm purple;  
 The ice-fettered brooks their freedom await;  
 A blithe voice sounds in the top of the maple,—  
 It is the chickadee calling his mate,  
 In words that lovers can only translate:  
     Chickadee—dee—dee  
     I love thee—thee, thee,  
     Phoebe—Phoebe.

## GOLD FISH

The most beautiful, interesting, and least troublesome of pets. Our Fish are raised from choice stock of hardy breeds. We manufacture a line of attractive metal frame aquaria, suitable for the most beautiful home, conservatory or college. Special sizes made to order.

Imported Japanese and Chinese fish. Aquarium plants, fish food, globes, castles, aquarium cement.

*Illustrated Circular Free.*

**PIONEER GOLD FISH INDUSTRY**  
RACINE, WISCONSIN

# American Fern Journal

**Official Organ of the American Fern Society**

Issued quarterly: Subscription, ninety cents per year.

Includes articles of both technical and popular interest with illustrations.

Editor, R. C. Benedict, High School of Commerce, N. Y. City.

Business Manager, E. J. Winslow, Lasell Seminary, Auburndale, Mass.

## *The Guide to Nature*

Edited by EDWARD F. BIGELOW

A Monthly Magazine from the Naturalist's Point of View.

An interchange of observations by students  
and lovers of nature.

*Nature is good in the school, because it is good  
anywhere for all people.*

Subscription \$1 a year      Four months' trial 25c.

Single copy 10c.

**THE AGASSIZ ASSOCIATION**  
**ARCADIA**

**SOUND BEACH      :      :      CONNECTICUT**

Kindly mention The Nature-Study Review when replying to advertisements

# THE NATURE-STUDY REVIEW

VOL. 13

FEBRUARY, 1917

No. 2

## Dr. Elliot R. Downing

Retiring Editor of THE NATURE-STUDY REVIEW

We are glad to give to our readers this excellent portrait of him who has for six years given his time and energies to the editing of THE NATURE-STUDY REVIEW with whole-hearted devotion. At the death of Professor Fred. L. Charles, so deeply lamented by us all, Dr. Downing took charge of THE REVIEW and thus rescued it from suspension; for, at that time, there seemed to be no one else at liberty who had sufficient interest in it to keep the little magazine alive. Nor was Dr. Downing at liberty, for he like most professors in most Universities, had plenty to do in conducting his department and in teaching his pupils. Yet he has, during these six years, sacrificed his scant leisure to work for THE REVIEW and has done so cheerfully and with faith that the result was worthy the sacrifice. Surely his efforts have met with universal appreciation and response.

Dr. Downing has always held THE REVIEW up to a high standard, especially in its scientific quality; and he has sought earnestly to keep it in touch with the work of the public schools and with all phases of civic biology. He has made it a periodical of which we all have been proud, and it is with universal regret that his resignation as editor has been accepted. He pleads for a vacation and an opportunity to devote his leisure to personal work in which he is deeply interested. However, we are not without hope that he may some day be persuaded to resume his editorial connection with THE NATURE-STUDY REVIEW.

Dr. Downing was born in Boston, November first, 1868. He graduated at Albion College in 1889 with a degree of B.S.; he then became Instructor in Science in Beloit College Academy. He received the degree of M.S., from Albion in 1894 and the degree of Ph. D., from Chicago University in 1901. He held the position of Professor of Biology in the Northern State Normal School of Michigan from 1901 to 1911 and then was made Assistant Professor of Zoology in the School of Education of Chicago University, and since 1914 has been Associate Professor of Natural Science in this institution.

## The Annual Meeting and Election of Officers

At the business session of the Society, Wednesday morning, December 27th, 1916, the secretary of the Society was instructed to cast the ballot for L. H. Bailey as president. The following persons were elected as vice-presidents by ballot: B. M. Davis, E. R. Downing, C. F. Hodge, A. L. Matthews, Alice J. Patterson. The five persons whose terms of office as Directors expired this year were re-elected, the secretary being instructed to cast the ballot of the Society for them, as there were no other nominees. The resignation of E. R. Downing as secretary-editor was accepted as he desired relief after more than five years of service. Mrs. Anna B. Comstock was elected secretary-editor. At Mrs. Comstock's request Miss Cora Smith was elected news editor and Professor J. A. Drushel ( St. Louis, Mo.) and Prof. John Dearness (London, Ont.) were also added to the editorial board. It was deemed advisable to extend the board still further but the additional members were left to be appointed by the Council. The Council as at present constituted is as follows: (Those directors whose names are followed by (1) continue for one year or more; those marked (3) were elected this year for a period of two years; those indicated by (3) are representatives of local sections and hold until successors are elected by such sections.) President, L. H. Bailey, (N. Y.); vice-presidents: B. M. Davis, (Ohio), E. R. Downing, (Ill.), C. F. Hodge (Ore.), A. L. Matthews (Utah), Alice J. Patterson, (Ill.); directors, (2) Anna B. Comstock (N. Y.), (2) John A. Dearness (Ont.), (3) H. C. Draye (Mo.), (1) J. A. Drushel (Mo.), (3) F. W. McBride (Ind.), (2) L. H. DeWolfe (Nova Scotia), (2) J. G. Needham (N. Y.), (1) C. H. Robison (N. J.), (1) S. C. Schmucke (Pa.), (2) W. A. Slingerland (N. Y.), (3) G. Straubenmueller (N. Y.), (1) Gilbert H. Trafton (Minn.), (1) R. E. Wager (Ill.), (3) W. W. Whitney (Ill.).

---

### On the Wind in February

On the wind in February,  
Snowflakes float still,  
Half inclined to turn the rain,  
Nipping, dripping, chill.

Then the thaws swell the streams,  
And swollen rivers swell the sea:  
If the winter ever ends  
How pleasant it will be.

—CHRISTINA GEORGINA ROSSETTI.

## The Great Lover

L. H. BAILEY

Address of the President at the meeting of the American Nature-Study Society, December 27, 1916.

"All mankind loves a lover." Thus saith Emerson, philosopher of the over soul.

The world loveth a lover because he is idealist and enthusiast. Breaker of precedents, violater of experience, he gives himself over to the demands of his soul, and lives in his dream as if the dream were the greatest verity. All things doth he subordinate, all obstacles doth he neglect, all transient enterprise doth he scorn, that he may attain, that he may attain quickly and completely. His eagerness bears him on, buoys him beyond despond, electrifies his eye. To every fellow lover he talks of his love, explains it with the abandon of youth, and is never hindered or abashed when the cynic on the four-corners of life scoffs at him and asks him the way. To him the way is plain,—straight ahead, straight ahead, on with the glow of hope and still on without the shadow of faltering. And the farther he goes and the warmer his ardor, the more do the people applaud. Verily, all mankind love a lover!

When two souls meet with their loves, ardently and unashamed do they talk of them. Whether the object is woman or man, or the far pursuit of a desire that hath become a dream, it counteth not, for they relieve themselves to each other. What any two persons love, that becometh the password.

The greatest rewards are the enthusiasms. The enthusiast is the lover. Enthusiasm brooks no precedent. It is not a lawyer immersed in tomes of old decisions. It is not a dogma, embalmed in sad history. It is the free outlook to the future, the democracy of the mind, the refusal to be bound and tied. It is the solvent to the soul.

Every good student is a lover. One is a lover of books, searching in the dim corridors that he may discover and resurrect a great hope. One is a lover of words, following them in their devious and fascinating histories. One is a lover of the stars, going in far journeys beyond any man's journey. One is a lover of his fellow men, forgetting himself. One is a lover of architecture, building himself on beautiful forms and painting his dreams

in colors. One is a lover of the earth, marvelling in its wonder, renewing himself in its youth. Infectious is the love of the lover. We as teachers feel it. We live with the enthusiasm of these precious teachers whom we teach. We try to aid them to realize their loves.

The great loves are these: the love of life; the love for another and of one's fellows; the love of things; the love of the earth. Remove any one of them, and life loseth its savor and there is no completeness. The love of life and of another need no urging, neither any explanation from me. The love of Things should need no explanation, and yet do we misunderstand. So much have we suffered that we discard the things we have seen in our sufferings. So common is our suffering that every common object is a token of it. Many are the travellers who look with a shudder on everything that belongs to a ship. Certain objects are emblems of mourning. Certain forms, odors, sounds, set us into sadness. Only in the objects and the scenes that we cannot see do we find freedom from old associations. What we call the ideals have been the incomparables.

Yet now do we find in Things their intrinsic beauties, fashioned of God just as truly and just as completely, do we believe, as is the soul of man. Good are they because they are what they are, not because we would have them otherwise. The divinity is in them, the divinity of origin, of perfectness, and of mystery. Not one of them do we understand. The heavens were beyond the ancients, so that the heavens declared his handiwork. The cell is beyond the moderns, so that the cell doth declare his handiwork. The amphioxus is beyond us, as truly as are the stars. The slow scarce-alive amoeba is beyond us, the sparrow that falleth is beyond us, the lilies of the field are beyond us.

Verily, all these are the marvels. Verily all these are good to know. Within the bosom of the planet are locked all these mysteries, yet not forbidden to anyone, not withholden of any man. They do not represent the old racial sorrows, as once we thought they did. New and yet old, changing, moving, drifting in the great flux of life, they are ever mature and ever in the process of creation, perishing utterly and yet reproducing their kind.

Here today in this great Convocation Week fifty societies meet, devoted all to the love of the earth. These people devoted to these great ends are, as I think of them, the great lovers. The



enthusiasm of these many meetings. the fervent greeting of one to the other, are the burnings of love. Forgetting for the time the sorrows and the contests of life, we come here for one week in recuperation. Now will you hear me talk of my plant. Now shall I listen to your story of your discovery. Now do chemistry and botany and physics and zoology and mathematics all weld themselves into fellowships. In the old celestial philosophies whereby man was a pilgrim and a wanderer in a vale of tears, feeling blindly for the route home, these things could not be. Here is our home. Here are we all together. Here is the abounding earth. Here are the Things, here the Phenomena.

These fellowships, these loves of the lovers, must be all to the good of the race when considered in the large. Selfishness is yet an attribute of the human mind, perhaps a remembrance of the old savage struggle for food and for mates. But as we discuss things in common, so do we forget the old limitations. If international friendships are ever to be restored after the Great Collapse it will not be by the meeting of kings, of cabinets, of diplomats, of politicians, of theologians, of lawyers. It will be by the meeting in convention of students, particularly of students of science,—the term science very broadly considered.

But I must not take your time with imagery or entertain you with vagaries. I took the title of this address from a poet, a poet who loved life as all true poets must, and who knew that life is made up of the many small concrete experiences. This poet is Rupert Brooke, said by some to have intellectual kinship with Shelley and Keats, a poet lost in his youth in the Great War. Hear Rupert Brooke:

\*I have been so great a lover: filled my days  
So proudly with the splendour of Love's praise,  
The pain, the calm, and the astonishment,  
Desire illimitable, and still content,  
And all dear names men use, to cheat despair,  
For the perplexed and viewless streams that bear  
Our hearts at random down the dark of life.

So, for their sakes I loved, ere I go hence  
And the high cause of Love's magnificence,  
And to keep loyalties young, I'll write those names

---

\*Reprinted by permission of John Lane Co. from "The Collected Poems of Rupert Brooke."

Golden forever, eagles, crying flames,  
 And set them as a banner, that men may know,  
 To dare the generations, burn, and blow  
 Out on the wind of time, shining and streaming. . . .

These I have loved:

White plates and cups, clean-gleaming,  
 Ringed with blue lines; and feathery, faery dust;  
 Wet roofs beneath the lamp-light; the strong crust  
 Of friendly bread; and many-tasting food;  
 Rainbows; and the blue bitter smoke of wood;  
 And radiant raindrops couching in cool flowers;  
 And flowers themselves, that sway through sunny hours,  
 Dreaming of moths that drink them under the moon;  
 Then, the cool kindliness of sheets, that soon  
 Smooth away trouble; and the rough male kiss  
 Of blankets; grainy wood; live hair that is  
 Shining and free; blue-massing clouds; the keen  
 Unpassioned beauty of a great machine;  
 The benison of hot waters; furs to touch;  
 The good smell of old clothes; and other such—  
 The comfortable smell of friendly fingers,  
 Hair's fragrance, and the musty reek that lingers  
 About dead leaves and last year's ferns. . . .

Dear names,

And thousand other throng to me! Royal flames;  
 Sweet water's dimpling laugh from tap to spring;  
 Holes in the ground; and voices that do sing;  
 Voices in laughter, too; and body's pain,  
 Soon turned to peace; and the deep-panting train;  
 Firm sands; the little dulling edge of foam  
 That browns and dwindles as the wave goes home;  
 And washen stones, gay for an hour; the cold  
 Graveness of iron; moist black earthen mould;  
 Sleep; and high places; footprints in the dew;  
 And oaks; and brown horse-chestnuts, glossy-new;  
 And new-peeled sticks; and shining pools on grass;—  
 All these have been my loves.

Ye teachers, ye who stand so close to life, ye who have so firm a hold on objects and their phenomena, here is your better half. Here are the materials, and yet here is no materialism. Here are realities to your fingers, realities to your sight, realities to your nostrils. Here are things practical, abiding within the day. Here are things you know, every waking minute one of them or one like them—every minute of sixteen waking hours—one thousand realities every day.

In every reality lies the germ of your soul. In every one is an idea, expanding itself into a far look, into a flight of fancy, I hope expressing itself in a poem even if unwritten, building itself into your desire and power to teach.

Very precious are all these things. There is a divinity in them that challenges the best that any man or any woman has to give. Not long ago, freed on the bosom of the ocean, sailing across the tropics, I found the experiences of my many crowded years overwhelming me, solidifying themselves in my mind, and I wrote. What I wrote I called *The Holy Earth*. To judge from what I read and what they tell me, my readers seem to find in my writing only a vivid enthusiasm for the out-of-doors, and yet I attempted nothing less than a philosophy of life. Still do I feel the responsibilities of that philosophy and still shall I write. It is difficult to open the eyes to the nature in which we live.

A year ago I gave you my estimate of the contribution that the science-spirit may make to a democracy. Those remarks must have sounded strange to those who now contend that the free introduction of natural science into schools and colleges has resulted in the deterioration of character. So far as such evils have followed, it is not that science is inadequate to the highest results in human character, but rather than we have not yet learned how to use the vast treasures of fact and application that have avalanched us. We shall learn in due time that science is not merely a handmaiden to industry but that it may expand the soul.

Today, therefore, I come with poems in my hand. Today I would hear the heart beat. Today would I encourage you to every quest of science, to every minuteness and exactness of investigation, to every effort in the teaching of the young; but I would add to this the courage of the free spirit, the hope of the high look, the uttermost call of the soul. No bounds would I set to your fancy. I give you the reins, and I let you drive. I hope that the fancy which leaps from the very concrete to the very abstract will be precious to you. Fear not to prophesy.

## Spontaneity in Nature-Study

S. C. SCHUMUCKER

A paper read before the Nature-Study Society of the American Association for the Advancement of Science, New York, December 27, 1916.

Nature-study is slowly working its way into its own place in the schools of the land. In some it has a recognized position and its full share of the time. To many this seems a consummation devoutly to be wished. The longer I try to do my part in fostering its growth, the more certain I become that I want for it neither a place in the course of study nor an hour in the day's program. To me it seems altogether better that it should be a spirit and a method, pervading the work of the skilled elementary teacher. It should be the drawing lesson one day, the language lesson another, the geography lesson a third, a number lesson still another day, a special feature some morning at opening exercises, or a stirring round-up to keep the week's work from "petering out" on Friday afternoon.

Meanwhile the subject of the lesson should be determined by local circumstances perhaps more than in the case of any other study except the vocational training. With each recurring week new birds, new flowers, new insects come or pass, the weather fosters or forbids, the community approves or frowns. All of these must be taken into consideration. Then too, the other subjects studied should receive help and enrichment from the nature-study, and they will do much to decide what subjects must be considered. All of this militates most severely, it seems to me, against any attempt to arrange a program which shall be other than most general. The utmost latitude should be left to the teacher. Any program in nature-study should be merely suggestive to her in case she should find herself at a loss to know what to do.

After all, the great value of nature-study does not lie in the information gained. Most of the mere information acquired in our early school days is completely forgotten in later life. I wonder whether almost everybody has not found his geography nearly useless in following the movements of the armies in the present great war. I find there are very few things I remember with absolute accuracy out of my earlier school life. The earliest

is "The ostrich is a very large bird, he runs very swiftly." Where I got it I know not, but it is dimly associated with a town I left at the age of six. Three dates out of fifty we sing-songed still remain—"1607, Virginia was settled at Jamestown by the English; 1614, New York was settled at Albany by the Dutch; 1620, Massachusetts was settled at Plymouth (or so my memory runs) by the English." All the rest has faded. Reiteration has fixed 1492 and 1776 and, except these, almost every date in American history has fled. The multiplication table stands firm—the one fixed, useful series of facts that really positively lasted. Then, from my high school days comes "Ante, apud, ad, adversus" and so on through an interminable list of prepositions that govern the accusative case (I hope that is right). It were perhaps well could our early lessons last better, though of this I am not sure. Perhaps a merciful heaven has arranged the matter well.

This does not mean that I think there is no value in the work done in the elementary schools. But its value consists but little in the facts gathered, and very much in the processes learned and in the development gained.

Now nature-study is almost unique amongst the studies of the earlier school life. It consists of the study of things, not of words. It inculcates a habit, and should give the student the power of finding out things for himself. Of course while he is learning to look into things for himself, he should be gaining the power by gathering information that is worth while. In this matter we must not judge too harshly the information gathered either by these elementary students or by candidates for the degree of Doctor of Philosophy. No one knows which part of knowledge may prove worth while at some future time. It is almost equally difficult to tell which portion of our acquisition will, after a while, prove to be useless. In any event, I dread the effect of formally prescribing, rigidly foretelling, carefully drilling and conscientiously testing the information gained in nature-study.

The best results of this discipline show themselves otherwise than in valuable information gained. One of our great nature lovers has recently been doing what would seem to be his first extensive reading in the field of science. His later essays have passages that read perilously like examination papers in high school science. His earlier papers were altogether adorable, though now and then a fact is wrong, or an inference doubtful.

This latter trouble is not unknown in scientific contributions to learned societies.

The finest results of nature-study consist in an absorbing fondness for nature, in finding in her a solace and a refreshment from the worry and care of life, in gaining from her a culture without cost to those for whom costly culture is out of the question, best of all, in feeling in her the throbbing in-dwelling of a power not ourselves that works for, not only righteousness, but for eternal uplift in all things.

To talk of standardizing, prescribing, testing this is to fail utterly, it seems to me, in perspective.

Dean Bailey puts us in the right track in telling us, "When you think of the subject you teach you are teaching science: When you think of the child to whom you are teaching it, you are teaching nature-study."

My suggestion to the scientist in the matter of nature-study is clear and definite: Teach the facts, as many as you can, as clearly as you can, as connectedly as you can, as thoroughly tied up with the philosophy of the age as you can, but teach it to the teachers. Standardize this knowledge, try it, test it, all you will. Then say to the teacher "You come in contact with the child, you know the mind of the child, you feel the developing soul of the child; dip now into what we have given you. Sift from it what is good for your purpose, translate it until it is within the grasp and the interest of your children, enrich it with your own personality, and fill them with a love for the great realm of nature that shall send them out to talk to her face to face, to ask her questions, to find in her, strength."

My fear of what will happen if the scientist attempts to standardize and test the nature-study of the first four years of school life can be well illustrated by a story told by the best primary teacher I have ever known. Miss Sara Arnold, while supervising the primary schools of Boston came one morning into a room where one of the teachers under her charge was hearing a class in geography recite a lesson on Newfoundland. "John," said the teacher, "what is fishing?" Now John had been sitting listlessly before he heard this question. The teacher had thus far failed to win him. But at this he awakened. This was the first sensible question he had heard since he got into that school. With light in his eye he started, "You git a hook—" "Next,"

said the teacher; "Willie, what is fishing?" Now Willie had also wakened. He thought John had not started early enough in the process to suit the teacher. "You git a worm—" "Next," said the teacher, and the amazed Willie sat down dumbfounded beside the equally non-plussed John. The next was Mary to whom a hook was a fearsome thing and a worm an impossibility. "Fishing," said Mary, "is the chief industry of the Province." "Right," said the teacher.

The moral of this story lies in its pathos. If this teacher had known the things that made for her peace, she could have gripped those boys to her with hooks of steel. She would have stood John up to talk on what he really knew. Lapses in grammar and in pronunciation might have gone unchecked for the time, and he would have proudly learned that he knew things the others did not. And Willie would have joined in the game. Newfoundland could wait until tomorrow, for two souls were finding themselves, and a teacher was entering into two lives. But the door into paradise, swung open for a while, closed and the teacher "never could know" what she missed. She had been over-standardized.

---

### Notes on New York Meeting

A friend of the editor who is a general nature lover and whose special interest is geology, came into the meeting of the American Nature-Study Society in New York on Wednesday afternoon, December 27th. He had been attending as many as possible of the multiplicity of meetings that always occur in connection with the A. A. A. S. and he said he had found the Nature-Study meeting the most interesting of any which he had yet attended. He spoke especially of the fine spirit that was manifest there.

A Cornell student also drifted into the meeting and his comment was, "It was full of pep," all of which was very gratifying to hear. There is never a large attendance at these meetings but there are always people present who have the nature-study movement at heart, and who are alive to the questions therein discussed.

## Standardizing Nature-Study

F. L. HOLTZ

A paper read before the American Nature-Study Society, Dec. 27, 1916

In the older studies of the curriculum, such as arithmetic, reading, spelling, etc., we find more or less general agreement in regard to what should be taught, why it should be taught, and how. This is the result of long experience in these studies and, no doubt, such uniformity has made for definiteness and efficiency in teaching.

By contrast the newer aspirants among the school studies, such as civics, hygiene, music, and nature-study are the matter of much pedagogical dispute. Even among their advocates is found the widest variance as to their educational purposes, how they should be taught, and just what or how much of the subject should be given. The reason is that they have not yet emerged completely out of the experimental stage. We have not yet agreed upon the standards of aim, method, and subject matter that should be the basis of a course of study in these subjects. The result is a wide diversity of treatment, as in nature-study, for example, throughout this and other countries. In some places nature-study is taught with scientific formalism, in others for its utilitarian purpose, in still others for esthetic and sentimental reasons,—and the subject matter and the method vary correspondingly widely.

Some may say, "Why bother to set up definite standards in nature-study?"

Let us consider the value of standards in general school subjects:

There are usually several aims in the teaching of a subject. These are not of equal value. It is the business of educators to experiment, to see which aims are capable of realization, and to determine the relative importance of the various aims. In the course of time there generally results a concensus in regard to these points. Clearness of aim in the teaching of a study is essential if the study is to be successful.

The purpose or aim being established in a study, the principles and methods of teaching it must be worked out. Here again experiment must show the way. Those principles and methods most surely accomplishing the aim of the study should be selected.



Naturally the principles and method will be largely determined by the aim.

Finally the choice of subject matter will be largely, though not entirely, governed by both the aim and the method. Of course the subject matter has also a reflexive effect in determining the method of teaching.

Aim, method, and subject matter in a study being thus scientifically determined, we can say that standards of teaching the subject have been evolved. The treatment of the subject is then largely beyond dispute and there should be general uniformity and presumably greater efficiency in the teaching of the study.

Now shall we thus standardize nature-study?

What could be the advantage? In the first place we should have a definite statement of what we are teaching nature-study for: Whether for general academic knowledge, for practical knowledge, for esthetic-literary purposes, or for all. If for all these purposes, what the relative importance of these aims is.

We are already getting together on these questions. The tendency is toward a practical nature-study, but there are many strong advocates toward including and even making predominant the other values. As to methods, there is a fair agreement that the direct or observational method should be the chief way of presenting nature facts. But here again there are differences of opinion,—varying from advocacy of formal science to informal conversation; also there are those who would use an artistic or literary medium of presentation, especially in primary grades.

The greatest variation as to nature-study is to be found in its subject matter. This varies immensely depending on the age of the pupil, upon the natural environment and the economic interests of the community. You can not have the same course for New York city as for a country village.

And yet we can discern some tendency toward the inclusion in the course of some facts in all courses. For example, we find in all courses the care of domestic animals, care of house and garden plants, the life cycle of a plant, life cycle of an animal, adaptive devices in nature, economic aspects of nature, nature-study applications in hygiene, etc. No doubt, as time goes on we shall find a greater agreement.

Are we ready to standardize nature-study? Shall we appoint an educational committee that shall be authorized,—like the

famous committees of the N. E. A. in history, etc.—to establish standards for nature-study?

My own opinion is that it is not wise now to attempt such standardization. I do not think we are ready for this step. Nature-study is still in the experimental stage, and the permanent value of aims, principles, methods, and subject matter are still in question. The whole traditional curriculum is at present under fire. Much of it will soon be changed. New points of view are being developed in elementary education. In this transformation nature-study will be affected. That is another reason why we should not be hasty about establishing definite standards for this study.

I am not sure that we can or should ever formalize nature-study like arithmetic or even geography. I think it should and always will retain a certain flexibility. The educational field of nature-study is too wide to permit very close standardizing for the whole domain. It is, in my judgment, better to standardize a course for large cities, a course for rural towns, and an agricultural course for the country districts. If we did this there might be some hope for agreement. I believe the best we can do now is to continue to experiment in nature-study, and for the educational leaders in nature-study to pass on the relative values and educational usefulness of present practice, guiding the subject along what they consider the best tendencies, and gradually coming to agreement, if possible.

In this way some day we shall be able to convince educational workers and school authorities as to the advisability of conforming to a somewhat flexible set of standards for nature-study.

---

“High wheels the gray wing of the osprey,  
 The wing of the sparrow drops low;  
 In the mist dips the wing of the robin,  
 And the snow-bird's wing in the snow.  
 Ah me!  
 Chicadee!  
 The snow-bird sings in the snow.

I love the high heart of the osprey,  
 The meek heart of the thrush, below,  
 The heart of the lark in the meadow,  
 And the snow-bird's heart in the snow.  
 But dearest to me,  
 Chicadee! Chicadee!  
 Is that true little heart in the snow.”

HEZEKIAH BUTTERWORTH.



## A Plan for the Study of the Elm Tree in Primary Grades

By SUSAN B. SIPE

Teacher of Gardening in the J. Ormond Wilson Normal School,  
Washington, D. C.

The aim of this lesson is to encourage a feeling of ownership in one school-yard or neighborhood tree; to teach the changes that a living tree passes through in a year, to teach the value of trees to the pupils and to other people.

Work preceding the lesson upon which the teacher had to build the new lesson:

1. Gathering of leaves from day to day by the children for October's party, with incidental talks on their colors and shapes.
2. By the study of a plant in the garden they have learned that the plant is held in the ground by its roots; that the stem holds the leaves up to the sunlight; that the leaves need the sunlight; and that there are flowers and seeds.

### FALL LESSON

As the leaves of different trees are brought in, and the elm leaf is among them, the teacher should frequently say. "These are

leaves from our elm tree. We will find it some day" or "These are leaves from our tree. We will let you show it to us some day." When the opportunity arrives some of them will be ready to show the rest of the little ones the elm tree or our tree. "Let us make a circle as large as our great sunshade." Children joining hands make a circle under the tree as large as the crown of the tree. "Now let us see how many it will take to stretch around the handle of our big umbrella." Only two for this tree because it isn't such a large one; but there have been elm trees that need such great trunks to hold their leaves up to the sunlight that it would take six of you to reach around them.

"Let us see how large those great sticks are!" (six children make a circle). We won't say that our great elm tree has a stick trunk or handle but we shall say it has a trunk. Our zinnia plant had a stem to hold its leaves to the sun. Trees have trunks. I wonder what makes our great elm umbrella spread out so far. The big trunk breaks up into smaller ones called branches just like the ribs of the open umbrella. Hold your arms up the way the elm tree holds its branches. Because the elm tree's branches spread out so far it is a fine tree to plant on streets."

"Now let us play this is a street. You are the elm trees on one side of the street, and you are the ones on the other side. (Separate the children into two lines). Put your arms up the way the elm trees do. Then the street cars, and horses and wagons, automobiles and people pass along the streets, how do the elm trees help them?"

"I wonder what holds this great trunk with all of its green leaves in the ground?" Call to their memory the roots of the geranium plant. "How much larger the elm tree's roots must be, so large that some of us can sit in the little hollows between them where they begin to fasten the trunk in the ground."

"Let's pick up some of the leaves of our elm tree to take to school with us. Tell me something about your leaf, Mary," (probably color, green or yellow or shape). "Run your finger around the edge. Rub your finger from the top to the bottom, from the bottom to the top. Fold your leaf right down the middle at the strong rib." From a twig in her hand teacher should call attention to the buds that the children will call the elm tree's secrets. "We'll find out what these secrets are; though before we do, the snows will come and the rains will fall and the winds

will blow, but the elm tree will keep them tight and then suddenly tell us all about them."

Later visits to the elm tree will show the tree has changed its dress from green to yellow and still later that it has taken off its dress completely.

#### WINTER

Observations should be made from time to time during the winter. Its rough bark that insects can hide under, should be noted. The cocoons of the tussock moth can be gathered and it may be nuthatch or downy woodpecker will help in the gathering. During the winter observations always let them hold their arms as the tree holds its branches that they may feel the shape of the tree. A branch kept in the room will let them see the ladder like arrangement of the twigs that makes it so easy for the squirrels to reach the outermost branches. After a snow storm let them see how the large branches and the little twigs hold the snow. Winter is the time to talk of wood and what we do with it. The strong wood of the elm is used for barrels and wheel hubs.

When Washington's Birthday is being celebrated an historical touch can be given by telling them of George Washington, because he became the head of our soldiers standing under an elm tree. While that was years and years, and years ago the elm tree is still living and people buy little twigs from it to plant in school yards so that children may remember George Washington.

#### SPRING

Several weeks before the elm will bloom out doors, bring in sprays to force the buds to open. Talk of the fact that last fall we saw secrets on the tree that the elm would not tell until after the snows. So we shall watch to see what she has to tell. There will be the swelling of the buds. Then the little branches of flowers with their pollen easily shaken out and then the seeds that look so much like caps for a toy pistol. In connection with pollenation simply state that the little elm flowers need the pollen and so the wind whispering in the high tree tops carries it for them instead of the bees.

Finally the leaves folded like little fans will come from the bud and all of the elm tree's secrets have been found out. This in-door preparation will make it possible for the children to picture what is going on in the top of our elm when the spring finally makes

it put on first a brown dress, and then a pale green and then a deeper green color.

Watch the tree for the birds that may come. Perhaps an oriole may hang its nest far out on the sprays. The following poem may be taught after the full cycle of the tree has been seen.

I wish I were an elm tree,  
 A great and lofty elm tree  
 With green leaves gay.  
 The wind would set them dancing  
 The sun and moonshine glance in  
 The birds would house among the boughs  
 And sweetly sing. —*William Allingham.*

References: Under the Washington Elm at Cambridge by O. W. Holmes; Some Famous Elms of New England by O. W. Holmes; The Village Elm, by Irene Putnam.

The Penn elm was 283 years old when it died.

The Washington Elm had a leaf surface of five acres.

### Conservation of Wild Life

A special display illustrating the conservation of wild animal life and the most approved methods of game farming is a new feature announced by the College of Agriculture for the tenth annual Farmers' Week at Cornell, beginning February 12.

Mounted and live specimens of wild birds, fishes, and fur-bearing animals of economic value will be exhibited; models of houses, shelters, coops, vermin traps, and other appliances used in the propagation of game birds will be displayed. There will be a model farm fishpond and fish eggs in the process of hatching; furs of common wild animals of the state will occupy a part of the space in this exhibit.

The conservation movement, since its first application in the handling of government forests, has broadened until it now includes all forms of animal and plant life useful to man, and the college believes that this work with wild game and fishes is to be of increasing value to state and nation as our natural wild life is being constantly destroyed. With proper care and attention, it is stated, wild game birds, such as quail, ducks, and geese, may be reared on our farms just as we now raise pheasants in many places. Fresh water food fishes are disappearing from our lakes and streams and the future, according to those who have studied conditions, must look to the farm fishpond for a large part of its fresh water fish supply.



## Mountain Laurel

LEAH WHEELER,

Canandaigua, N. Y.

When, pale and pure against the sombre green  
Of spreading hemlocks, and close-crowding pines,  
In northern woods thy moonlight beauty shines,—  
Thou seem'st, O stately Kalmia, like a queen  
Alien and sad, exiled but not discrowned:  
A wanderer from distant tropic lands,  
But regal still, and bearing in thy hands  
Caskets of pearl and rose, securely bound.  
Fair fugitive, I would not be too bold,  
Nor seek to probe thy hidden history;  
I pluck thy blossoms, not thy mystery;  
Yet I were rich indeed, with wealth untold,  
If in some trusting hour, thou wouldst unfold  
The secrets that those cunning caskets hold.

—*E. Shaw Forman.*

All the year the smooth, pointed green leaves of the laurel stand out boldly from the grey monotony of the rocks and hillside over which it loves to clamber, but only in middle June when these hillsides are apparently covered with a mass of pink snow

can we appreciate the beauty of our laurel. No flower of wood, field or marsh can surpass the beauty of a freshly opened bud, when it deepens and fades to paler tints according to the location, soil, etc., and its own individuality.

Its scientific name is *Kalmia latifolia* and it belongs to the Heath family which is familiar to us since it contains the azaleas, rhododendrons, and the dainty trailing arbutus. The buds and newly opened flowers are rose pink in color, but these fade to white with only pink lines showing. The flowers have been compared with little, quaint five-pointed umbrella tops with ten recurved stamens for the spokes—each anther securely socketed till some bee alights. The sticky stigma is erect ready to receive the pollen from another flower which the bee has visited, and after hovering above the nectary the bee has only to descend toward it and possibly touch one of the curved filaments, when suddenly off will go the little "anther gun," discharging the pollen. So delicate is this mechanism that the least jar will release the anthers.

This laurel sometimes grows to a height of thirty feet in the mountains of Pennsylvania, and it is more or less abundant from Canada to Georgia. To transplant it, one has only to secure acid soil for a border, dig the plant up carefully, and transplant it, meanwhile being especially careful not to allow the roots to dry out. The laurel like the huckleberry needs acid soil to make it thrive.

This shrub is carefully cultivated in England, being known as *Kalmia*. At Barewood Gardens, the home of the editor of the *London Times*, there are many fine shrubs of this and of our rhododendrons. The English papers announce the blossoming season and the estate is thrown open to the public, people coming from great distances to admire our laurel.

The generic name is that of a Swedish botanist Peter Kalm, a pupil of Linnaeus, who gave the plant his name. Kalm traveled in this country early in the eighteenth century and became more impressed by its beauty than that of any other flower. He introduced it into Europe where it is so highly prized.

The classic shrub is supposed to be identical with *Laurel nobilis*. This was brought over by the colonists but it did not thrive in its new environment. However, our laurel belongs to this distinguished family of plants, which has crowned poets



and heroes, and this might well be an argument for having it as our national flower; besides it possesses beauty, strength and thriftiness, is adapted to sudden changes of American climate, and will thrive mid the most adverse surroundings.

In 1790 fatal cases occurred in this country from eating wild honey, which was traced to *K. latifolia* by an inquiry instituted by the government. Most cattle will leave it alone but it is said some become victims every year, as do the grouse and partridge when hard pressed for food. One of the swallow-tail butterflies deposits its eggs upon the laurel leaves, and the larvae feed with no ill effects. Dr. Barker says that Indians drink a tea made from *Kalmia* leaves when they wish to commit suicide.

The wood is very hard, fine grained and solid, taking a fine polish. It is in good demand, weighing 44 pounds to the cubic foot. One of its uses is indicated by the name "spoonwood."

---

### The Newark Museum

The museum as an educational factor is coming more and more into prominence. If anyone has an interest in the subject let him send at once for the pamphlet, "The Educational Value of Museums," published by the Newark, N. J. Museum Association. This brochure discusses the subject to right and left, front side and hind side, top side and bottom side, with a vital verve that sets the reader tingling to create museums or get in touch with live ones. It gives cogent reasons for establishing museums and for continuing them and best of all discusses their possibilities as agencies for educating a city. The pamphlet is written by Louise Connolly, with an introduction by J. C. Dana. Miss Connolly came over to the nature-study meeting at New York and gave an address, as delightful as it was pungent and true, on the nature-study propaganda, the manuscript of which arrived too late for this issue of the REVIEW but will appear in the March number. Miss Connolly is doing sincere and important work in nature-study in the Newark Museum. She was a most successful teacher before she was connected with museum work and every step she takes is in the right direction to make for true education.

## A Brook Acquaintance

CATHERINE BARD

Gowanda, N. Y.

Once upon a time, quite a long time ago in fact, there were two little springs in some woods, not so very far away from here. And these little springs just bubbled away, all day long, without doing anything very much, except to bubble in the summer, and sleep in the winter, and perhaps play with the birds and skunks who came to drink. And it wasn't very exciting. The little springs thought "My, wouldn't it be fine, if we could play together some day and what a lot we might do, if we could do it together!" So both of them being little springs and anxious to see each other started out to meet. Each decided that it had better get out of the woods first, because it would be so much harder to find the other in the thick tangle. They took the easiest way they could find, and rolled down into all the little hollows which they saw, and whenever they came to a hill, they ran down pell-mell. Of course, they met other springs on the way, who were just as lonesome, and they were asked to come along, because the first little springs knew just how they felt, so that by the time they were out of the woods, the first two little springs had several other little springs coming along with them, and each was a brook by itself. But they kept on going just the same, because they were started now and couldn't stop anyway. They went through a field, where the grass tried with all its might to make them stay with it, for it squeezed the brooks up into just little threads with its roots. But the little brooks were getting anxious now, because they saw that it wouldn't be long, before they would see each other. Soon they came to a road, and they never had seen one before, and didn't know how to act when they met a road. They would have been angry and would have torn it right down, if they had not been shown that there was a nice pipe, which they could run through. After they had gone under the road, they knew that it could be only a little time before they would meet at last. One little brook did not hurry very much, but played along with the deep grass and green things growing in it, and gave away lots of water to the dry walnut trees, which leaned over it. But the other one was more anxious and tumbled down over big rocks and down a hill in a hurry, although it did leave



"Some pools and quiet places for beetles,  
water-striders, and crayfishes to play in."

some pools and quiet places for beetles and larvae to play in. And then they met! After all this time! But instead of hurrying on, as you might expect, they got acquainted with each other and spread out in a big broad marsh, where cat-tails liked to grow and red-winged blackbirds had their nests. Together they filled a broad, deep place, which took up more room, than they had ever filled before. After a little while, they decided to move on a little; the two of them pulled together and were now one brook; this ran on for a little while until it wanted to play some more, and made another marsh. The next time it decided to move on, it had to go, like a very well-behaved, civilized brook, because somebody made a very proper and straight sort of a course for it through a meadow; under another road it went, and came out again and made pools where it wanted to among all kinds of stones, and where beetles, water spiders, cray fishes, and other brook animals could play on it and in it.

Many kinds of trees gathered around the brook, leaning over it to hear what it was saying, for it moved along faster and was having a better time than ever before, so that even the bushes came close to it, and as the brook hurried along they got so interested, that they almost hid the water and you couldn't see it at all, except by scrambling through raspberries briers and wild cherry trees. Once it made an island, which was not as big as Robinson Crusoe's, but was a wonderful island just the same. Lovely flowers, violets and trilliums came and grew upon it, and the brook was very happy. It grew very lazy in its happiness and lapped around the island, making its edges marshy. But even an island couldn't stop the brook now, and soon it hurried on faster than ever, so fast that it washed all the stones from the smooth rock and then it slipped along the stone steps at a great rate.

But not all the time, did the brook hurry so. Sometimes it slowed up, around some trees which fell into it; here it left stones and sticks which it had carried along, and these would form a little dam and a pool for birds to drink in, and for minnows to swim in. The banks around the brook were, Oh! very high now, and there was room for so many trees that it was almost like a woods. The brook enjoyed this very much, and felt very glad that its springs had started out to find other brooks, for it felt that these ferns and trees and flowers were its very own, and liked

to be so near it. Else why would they have come and grown there? Then, because it was so happy the brook laughed in the brook's way of laughing of course, which you know is to find some big stones and then ripple over them and the result is the most musical laugh, you about ever heard.

By this time, the little brook was growing up and had higher banks and taller trees around it, and was beginning to feel that it had really better be doing something besides play along its banks forever. So it hurried on ever faster, and sang over its waterfalls and laughed over its stones ever and ever louder; and very soon, coming to the edge of the hill, it saw ahead, a brook much larger than it had ever hoped to be,—a creek. And the brook said "Now, I know what I will do. I will go along with that creek, where it is going. That will be doing something splendid certainly." So it was about to plunge over the hill down to the creek, when it met a big strong dam at the very top, which some men must have made. This kept the brook from going as fast as it wanted to, but nothing could hold it back entirely. It fell over the dam, on the smooth slippery rocks a long ways down and then gathered itself together and made a grand sweep around, just as though it were trying to show that it could do most anything, even turn its back on the creek, and yet go there just the same. And then what do you think? Instead of rushing up to the creek with a loud how-d'ye do, the little brook, when it was not far away, modestly sank into the ground, and went to meet the creek in that mysterious way. So we really never saw the brook reach the creek, but we know it got there, because it was such a determined little brook. And what the little brook and the big creek did, you must read in the next chapter.

---

'Tis the world's winter;  
Autumn and summer  
Are gone long ago.  
Earth is dry to the centre,  
But spring, a new comer,  
A spring rich and strange  
Shall make the winds blow  
Round and round,  
Through and through,  
Here and there,  
Till the air  
And the ground  
Shall be filled with life anew.

ALFRED TENNYSON.

## The Red-headed Woodpecker

By MARY LOESCH

Kindergartner in Madison School, Pittsburgh, Pa.

One fine spring morning late in April a red-headed woodpecker flew upon the telegraph wire; he sat there looking about as though he were looking for someone and since no one was in sight he began drumming on the wire to see if he could drum up someone. Soon two more woodpeckers came, one was a Mr. Red Head and one was a Miss Red Head. The woodpecker on the telegraph wire noticed Miss Red Head and thought he would like to have her for his wife. He could not sing to her because he has no song, but he kept on drumming until she thought he was the finest drummer in the world; finally she flew down on the ground, then down he went too, he made a nice bow to show her his beautiful red-head, then he stepped forward and backward then sideways and then he made another bow coaxing her all this time to be his mate; finally she decided to go with him, so they flew away together to the woods to build a house to live in. They began talking of house-keeping, for each kind of woodpecker has its own style of housekeeping. They build in either the trunk or branches of a decayed or hollow tree, if they cannot find one of these, they build in a sound tree. It took several days for these woodpeckers to find a desirable place to live, because they wanted to be surrounded by other trees. At last they found a place that both of them liked very much. The first thing they did was to strike out a circle in the bark as large as the doorway was to be and this was just large enough for one of them to go in and out one at a time and strange to say they made a perfect circle all of little dots. If you think this is easy just try to draw free-hand a circle of dots just like the one the woodpecker strikes out with his bill and see whether it is easy or not. Just as soon as the size and shape of the doorway suited the woodpecker he began to scale off the bark inside his circle of holes, and while he was doing this work, he clung to the tree with his stout toes and braced himself by his pointed tail, the chips flew out past him as he dug, if they dropped into the hole he swept them out with his bill and dug again. The pair took their turn at doing this work and it took a week or more to dig the nest, which extends horizontally for a few inches then curves down ending in a little chamber large enough to make a



Red-headed Woodpecker

comfortable nest for the mother bird and also the baby birds when they should arrive.

It was either in May or June that the mother woodpecker laid six glossy white eggs in the nest. Then she sat there for two weeks; she did not have a place to look out, for you know the woodpecker's home has no windows, but by and by six little naked blind helpless nestlings came, then the parents were very busy getting enough food to fill these hungry babies; they would catch flies on the wing and drill holes into the bark of the tree to find other insects hiding there. No one could disturb these babies, unless it were the little squirrel; they would lie in their warm dark nest and as soon as they could see they would look up at the ray of light that came in through the doorway, until they could hear the scratching of their mother's feet as she alighted on the outside of the tree to feed them. In about two weeks the babies were fully feathered and were able to climb up to the top of the nest from which they could look out of the doorway with great curiosity but if they heard the slightest noise they slipped back into their nests, but in a day or two they were ready to leave their nest and began to fly. They loved to fly to the tin roofs where the children live and drum a merry tune.

Then they all began to store up food for future use, they stored up acorns, insects, and nuts, especially beechnuts; they put them in little holes and crevices, cavities of old tree-trunks, in fence posts, and, even in crannies in barns. They have all kinds of storehouses. You know their bill is like a little pickaxe so they have no trouble in getting the food out of these places. At first the baby birds do not look like their parents; they are gray and do not have the beautiful red-head and breast with a blue black color on their back and white below, but it is not long before their gray head turns to a beautiful red and they wear the black and white uniform and become real red-headed woodpeckers.

Ah, may I be as cheerful  
As yonder winter birds,  
Through ills and petty crosses,  
With no repining words;  
So, teaching me this lesson,  
Away, away they go,  
And leave their tiny footprints  
In stars upon the snow.

—GEORGE COOPER.





## February Nature-Study

ANNA BOTSFORD COMSTOCK

To the nature-lover February is the winter month of special charm. The forests on the snowy hills take on many lovely tints varying from dull to dark blue and from lilac purple to amethyst. The snow is toned with purple shadows and the skies in the morning are dull blue at the horizon and rosy and misty above until the blue of the upper skies is reached. Let us enjoy every day of February whatever the weather and then will our spirit be strong for blustering March.

### SECOND GRADE

*The English Sparrow.*—This doughty little brigand is always with us and always in the foreground until he discovers we are trying to study him, then he disappears like magic. For pupils of second grade a February lesson may be found in Obs. 1, 2, 7, p. 37.\* The cock-sparrow is a very difficult bird to describe, his coat is of so many shades and patterns but the children can see his black cravat and white wing bars and the white sides to his throat, all of which ornaments his peppery-tempered wife lacks. The pupils should be encouraged to listen to and understand as much as possible of sparrow talk. The chief value of this special lesson is to make the pupils perfectly acquainted with both sexes of this sparrow, that later, when they study birds in the field, they will not be confused if English sparrows appear on the scene; the hen-sparrow seems to have protean forms and is often mistaken for other species.

*The Bluejay.*—This bird of heavenly hues is a joy to the eye and a pain to the ear. The pupils should observe the colors

---

\*Reference to author of *Handbook of Nature-Study*.

and markings carefully. They should note that the back is not so blue as the wings, that the forehead and collar are black, that the wings and tail of exquisite blue are cross-barrred with black and tipped with white and the wing bars are white. The crest on the head of the bluejay is used to express his feelings and should be studied as a guide to his emotions. A pet bluejay is the most mischievous of birds. It will destroy books, upholstery, and almost anything that it can tear, and it will steal pins and jewelry. This bird is also an imitator and learns the notes of other birds, and seems to enjoy playing practical jokes upon his companions. One will scream like a hawk and then seem to chuckle to see all the little birds scared and seek to hide. The jays cease to be noisy at nesting time. They slip away, build their nest, and rear their young in some secluded spot, and talk in low tones to each other, and are as retired and modest now as they were formerly aggressive.

*Treatment of Pets.*—We cannot begin too early to impress upon children their duties toward the lower animals and especially toward their pets. Dr. Hornaday has declared that "being a pet is at best a hazardous occupation," and he being at the head of one of the largest zoological gardens in America should surely know. There are plenty of lessons to enforce the necessity of constant kindness and care to those creatures dependent upon the child, who should be impressed with his duties as caretaker. He should be made to think of what would happen to him if his parents should forget to give him food or drink for a day or two. The teachers should have talks with the children about the proper care to be given to cats, dogs, rabbits, guinea pigs, canaries, pigeons, goldfish, etc.

Reference—Pet Book, Comstock.

*The Language of Animals.*—Children are far more sensitive to the meaning of sounds made by animals and birds than are grownups. As a child I knew by the notes of my canary whether he was happy, discontented, angry, or merely talkative. I also knew at least twelve of the emotions expressed in the rather extensive language of the hens, and I never thought of mentioning this knowledge to anybody. I just knew it and that was all there was to it. I was alike conversant with the talk of the dairy herds and the pigs and the cat and dog. It is well to impress upon children that every sound made by bird or animal has its meaning

for its companions and that it is very interesting to try to discover these meanings for ourselves. I have seen many a dog that knew more of his master's language than his supposedly more intelligent master knew of his. Teach the children to repeat the lines from Hiawatha—

"Then the little Hiawatha,  
Learned of every bird its language." etc.

If Hiawatha learned the language of all the wild animals and birds, our little children should surely learn the language of their pets.

*The Big Dipper.*—It is quite impracticable for the teacher to take the children out for star gazing. Luckily this is not needful. The diagram Jan. REVIEW p. 33 should be placed on the blackboard and left there for a week or more. The children should be taught which direction is north and east and northeast. Then ask them to look in the evening at seven or eight o'clock in the northeast part of the sky and there they will find the Big Dipper with handle turned down, and they should also learn to find the North Star by the pointers.

*The Magnet.*—There is no plaything more fascinating to the children than the horseshoe magnet. While the extended lesson on the magnet is fitted only for the upper grades, the second grade children may learn many important and interesting things about the magnet. As to method the teacher should have two or three toy horseshoe magnets of different sizes and some tacks and iron filings. A magnet and some iron filings in a box cover may be given the child to play with during busy work or as a reward of merit. The questions and Obs. 3, 4, 5, 6, p. 840 may be asked a few at a time.

#### THIRD GRADE

*The Moon.*—As a teacher of University students in nature-study classes I have been astonished at their ignorance concerning the simplest things in astronomy and especially their ignorance concerning the moon, and I have been forced to the conclusion that all of these things should have been taught to them in childhood. The third grade children may be taught certain things about this little dead world that belongs so especially to us, before they begin physical geography. The phases of the moon may be shown by holding an orange or a baseball in the flash light in a darkened room and they can come to understand that

the light coming from one direction can only light half of the ball at a time. If the light is on the same side of the ball as we are, we see all of the ball facing toward us lighted, which is comparable to the full moon, but if the light is at one side we see only a part. Thus can be shown the full moon, the last quarter, the old moon crescent, the dark of the moon, the new moon crescent, the first quarter, and back to the full moon, simply by moving the light around the suspended ball. The experiment on p. 921-22 is too complicated for the third grade, but with the earth eliminated, Obs. 1-6, p. 922 suggest what shall be shown. The story "A Visit to the Moon," p. 919 should be read, or, what is better, told in simpler terms to fit third grade intelligence. By asking the questions on Obs. 18-29 on p. 923 a few at a time and talking over the answers with the pupils, a very fair start may be made in knowledge of our earth's one satellite.

*The Dog.*—The dog and his habits can be better understood by comparing him with the wolf which he resembles in form and habits and by contrasting him with the cat which he does not resemble either in appearance or habits. Obs. 1-3, p. 265 form the first lesson, Obs. 4, 5, 6 the second, Obs. 7, 8 the third, 9 the fourth, 10 the fifth, 11 the sixth, and 12 the seventh. The pupils should be encouraged to read all the dog stories adapted to their abilities. See supplementary reading, p. 267.

*The Cat.*—Puss is a very interesting animal and just at present her status as a member of the community is by no means settled. Times have changed since the days of Dick Whittington when a cat was worth her weight in gold. It is only through statements of history you can come to appreciate the economic importance of cats. Wherever pioneers have planted their crops, rats and mice have followed in abundance to help in the harvest. Therefore our forefathers especially prized the cat which helped them to save their grain from these marauders. The cat is still an important factor in keeping rats and mice in check. Our government appropriates money every year to support cats in the post offices and other public buildings. However, at present the whole economic question of bird preservation is before us and the cat is surely an enemy to birds. We should at least demand that all cats be licensed by their owners and that all stray cats be eliminated. Obs. 1, 2, p. 272 form one lesson; Obs. 3, 4, 5, p. 273 suggest material for another lesson; 6, 7, 8, 9 another; 10, 11

another, and 12 another with many comments by the teacher. Obs. 14 suggest several stories, all of which should have a bearing upon the habits of pussy. See three little volumes containing stories from *St. Nicholas* magazine; *Cat Stories*, *Lion and Tiger Stories* and *Panther Stories*.

*The Crow*.—The winter is a good time for beginning the study of the crow for that is the time this big clever bird is a hero. It endures the cold, flies long distances to find food to ward off starvation, and has been known to divide up his meager rations with his comrades who have been crippled through being frozen. Although I cannot say that I welcome crows to my bird feeding stations, yet I never see one sitting on a tree at a safe distance wistfully contemplating the food on the tree too near the house for his daring, without feeling sorry that I cannot feed him too. The crow is too wary to permit of close observation; but in most localities one or more of Obs. 1, 2, 3, 4, 5, 6, 7 and 14, p. 132 may be made. Thomson Seton's story of "Silver Spot" may well be made the basis for information about crow ways. "Crow Ways—Ways of Woodfolk" by Long; "Jim's Babies in Nestlings of Forest and Marsh" by Wheelock; "How the Crow Baby was Punished" in *True Bird Stories* by Olive Thorne Miller; and the story on p. 117 in the *Second Book of Birds* by the same author; and "Not So Black as He is Painted" in *Outdoor Studies* by Needham; and "Jack Crow" in *American Birds* by Finley should all be read to make the study of the bird complete.

*The Yellow Jacket's Nest*.—February is a far safer period for the study of a wasp's habitation than is July. The wasps deserve our respect for inventing wood pulp paper of a water proof quality and a study of one of these empty nests will be a revelation of the home habits of the little socialists who built it. A nest should be brought in and Obs. 1, 2 p. 435 be made, then the side of the nest should be removed (see p. 457) and Obs. 3 and 4 will outline a lesson. The questions in Obs. 5-10 may be answered from the *Teacher's Story* p. 432. The description of the colors of the yellow jacket as suggested in Obs. 11 may be made from a museum specimen or from one of dead specimens which is likely to be found in the deserted nest.

#### FOURTH GRADE

*The Cedars*.—In a recent number of the *Literary Digest* was given a delightful song to the cedars, quoted from "After Hours" by

William Frederick Weld. One stanza is especially appealing:

A toss of my cap to the cedars!  
 The lovingest trees that be.  
 The time tides roll and the seasons veer,  
 Yet tender, sweeter, year by year,  
 My cedars are true to me.

I like this because it expresses a personal relation of the poet to the cedars, the kind of relation with trees which I believe every human being is richer for experiencing.

The two species commonly called cedars are the Arborvitae or white cedar, and the Juniper or red cedar, and are the ones chosen for this lesson. There is also a Coast White Cedar and a Ground Juniper, planted in parks and grounds. The observations should cover the following: (1) The size of the tree. (2) The sketch to show its form and the direction of its branches. (3) If wild, where was it found? On hillside, open field, forest, valley, near a stream? (4) Color of bark. (5) A twig sketch showing how the leaves are set like scales upon it. (6) The red cedar has two kinds of foliage, one sharp and needle-like, the other scale-like. (7) A sketch of the fruit and the seed and also a written description.

*The Sheep*.—These beautiful domesticated animals are far more interesting than most people suppose. This study should be a serious attempt to understand how the sheep is fitted in form and habits for life in mountains and in countries where it developed as a wild animal. There are enough observations to be made on this animal and enough to learn of the various industries connected with sheep raising to provide lessons for the entire month. Obs. 1, p. 284 and Obs. 4, 5, 6, p. 285 form two observation lessons on the animal; Obs. 7 another lesson; Obs. 2, 3, 8 and 9 each suggest a subject for a written theme or a talk. Obs. 10 should lead to the reading of "Bob, Son of Battle" by Oliphant, and "Wully" by Thompson Seton, in *Wild Animals I Have Known*, and "The Kootenay Ram" in *Lives of the Hunted* by the same author.

*The Junco*.—This little slate colored bird so smooth and well tailored, so well marked by his flesh colored bill and the two white patches for flash colors in his tail, comes in numbers to the feeding stations in February and March. It should be of great interest to us to find a bird that thinks southern New York far enough

south to be a desirable winter resort. The junco nests in northern New York, Canada to Alaska. Their nests are built of grass, moss, and rootlets, and lined with fine grass or hairs and are built on or near the ground. The eggs are bluish white and spotted or blotched with reddish brown. The observations should cover the following: (1) Where is the bird seen? (2) Compare its size with that of the sparrow. (3) Its most striking colors. (4) Its flash colors. (5) The colors on breast, under parts, back, wings, etc. (6) The shape and color of bill. (7) Its actions. (8) Its flight. (9) Its call notes. (10) Its food..

*The Pleiades and the Hyades.*—After having studied Orion it is easy to find and become familiar with these two constellations. The accompanying map gives their position and relation to Orion. The Hyades form a V-shaped constellation, all the stars of which are small and faint except the one marking the end of the left arm of the V. This is Aldebaran, a red star and a very large one. It is a sun that gives off about forty-five times as much light as does our sun. Aldebaran in the minds of the ancients, was the eye of the infuriated bull which Orion is getting ready to strike.

The Pleiades seem to have interested people of all times. They seem to us to be six stars set in a halo of faint light, "just a little misty bunch of stars." Yet astronomers believe they form a great star system just being evolved. It is known that there are more than three-thousand stars in this constellation instead of only six, and they are so far away that the light reaching us from them must have started before Columbus discovered America. See lessons pp. 897-98.

**Snow Crystals**—These exquisite structures should be studied whenever it is possible to do so. It is one of the beautiful miracles of this world that, water vapor freezing in the air always develops six rays although these may be ornamented in many different ways. Mr. W. A. Bentley has with his microscope discovered at least fifteen hundred different types of these six-rayed snow stars. The crystals may be studied out of doors with a lens on a day when fine, dry flakes are falling; they should be caught on dark flannel. See last paragraph p. 851 and Obs. 12, p. 856.

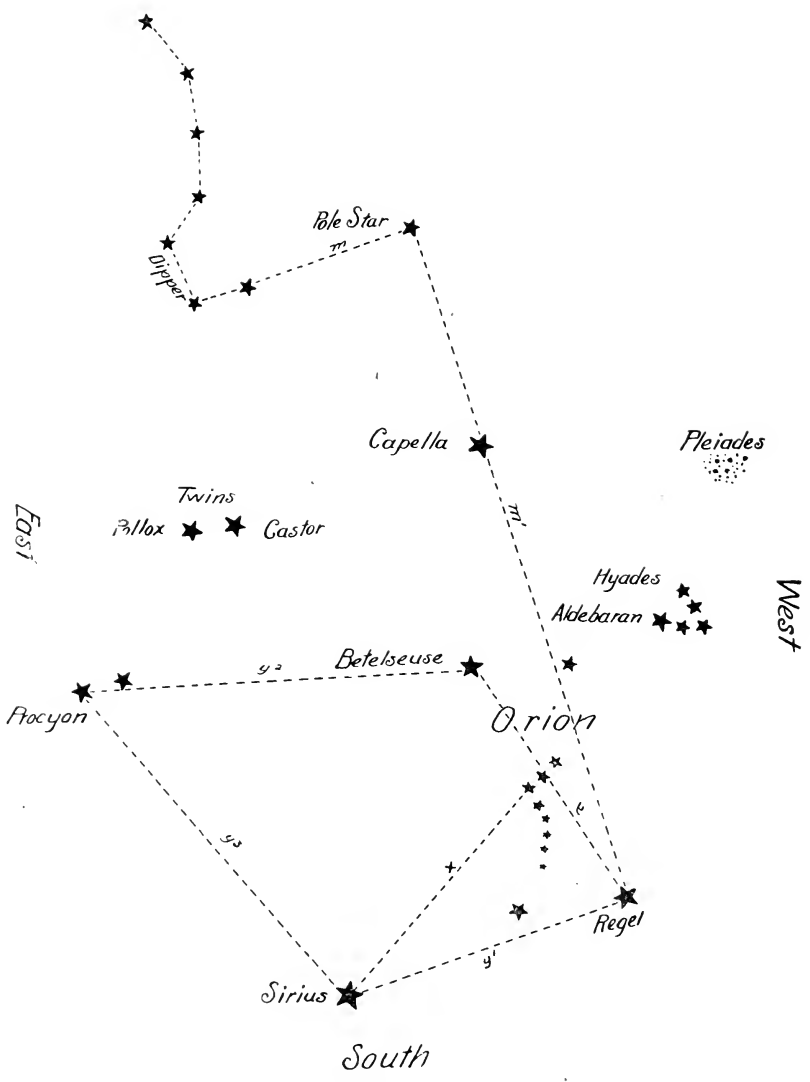

Hold this diagram above the head to find the stars.



# THE NATURE-STUDY REVIEW

DEVOTED PRIMARILY TO ALL SCIENTIFIC STUDIES OF NATURE IN  
ELEMENTARY SCHOOLS

Published monthly, except June, July and August. Subscription price, including membership in the American Nature Study Society, \$1.00 per year (nine issues). Canadian postage, 10 cents extra; foreign postage, 25 cents extra.

**Important** Please note date of expiration of your subscription on the label of the wrapper. Subscriptions must be paid in advance to comply with postal requirements. Subscriptions and advertisements should be sent to *The Constock Publishing Co., Ithaca, N. Y.* Manuscripts for Publication and Books to be Reviewed should be sent to the Editor.

---

## Editorial

It is with many misgivings that the newly elected editor of the NATURE-STUDY REVIEW assumes her duties; and her first impulse is to send a S. O. S. call for help to everybody interested in nature-study, asking them so send notes upon interesting happenings and accounts of their work, to be published in the REVIEW; the call also asks for private letters, explaining how the REVIEW may become of more real use to teachers.

Dr. Downing in his nearly six years as editor has developed the NATURE-STUDY REVIEW to its present state of efficiency and excellence. He has always held a high standard as to the scientific quality of its contributions, and as to its practical helpfulness to teachers; it is the earnest desire of the new editor that this standard shall not be lowered.

Sometime since, there was an informal meeting of several of the directors of the NATURE-STUDY REVIEW and there was a consensus of opinion that there should be in each number of the magazine direct aids for teaching, good natural history based on original observations, articles on civic improvement where such work impinges on nature, practical pedagogical discussions, garden work when combined with nature-study, some special helps for kindergarten and first grade, and in each number a little poetry. All the items in this plan seem good and an effort will be made to carry it out.

For one thing the present editor is deeply grateful,—she is to have the aid of associate editors, Professor J. A. Drushel, Director of Nature-study in Harris Teachers College in St. Louis, Mo., whose interest in the REVIEW has always been both keen

and practical, and Dr. John Dearnness, head of Normal School, London, Ontario, whose noble work in nature-study through many years has been of the greatest influence in the Dominion, and has reached out into the United States in a thousand practical and helpful ways, were elected as associate editors. Miss Cora Smith, teacher of Biology in the high school of Erie, Pa., was elected news editor. Miss Smith is an admirable teacher in Biology and an enthusiastic nature student, and she is perhaps more remarkable still for her human interests; she likes people because she is genuinely interested in them; she has an out-reaching and sympathetic spirit, and we hope through her to keep the REVIEW in close touch with the everyday work of many teachers and nature-study clubs throughout the land.

It is the present plan to have each number of the REVIEW specialize in some general subject. Dr. Downing found the bird number a great success and this encourages us to get together all the subject matter available on some phase of nature-study for each number. Thus the teacher can have in condensed form the work on trees, flowers, birds, etc. The March number will be given to the study of animals including fish, etc. The April number is to be devoted to spring wild flowers, and the May number to birds. If this plan proves successful it will be carried to a farther degree next year.

If any of our readers have any notes on birds, we hope they will send them to us by April first; the notes on wild flowers are due March first. We hope that each teacher receiving the REVIEW will feel that it is his or hers and will respond with notes to help make the magazine alive and of use.

---

### Winter Twilight

“No summer sunset afterglow  
Can match the soft rose of the snow  
Upon the pure-browed hill:  
Blue shadows fill the dells below,  
Sweet airs from fields of silence flow,  
And earth and sky are still.

Between the outer deeps of night  
And this low vale, the lingering light  
Builds of the evening mist  
High walls of glory fair and far;  
And in the glory shines a star  
Through trembling amethyst.”

—ANNA BOYNTON AVERILL.

## Book Review

*Wild Animal Stamp Primer.* New York, 2001 Park. 85c + 7c postage.

I have written, in the course of I will not say how many years, stories about almost everything under the sun; I do not like to think of the number of words I have put upon paper, and I cannot help but feel glad that all the words have not been printed, for the world never did anything to me to cause the exaction of such a penalty. Though my clippings show my offence has been severe, I still keep on writing—and receiving checks(?). But now I am going to tackle a new subject. I'll not say what kind of a writer I am, but I know I am no book reviewer; yet the new subject is a book, and I'm going to say a little about it.

The book in question is so new, novel and interesting that I feel that I want to tell others about it, and if they are half as much in love with the outdoors as I am, I believe they will find it as entertaining and instructive as I did, even if it is supposed to be a "kids' book." In fairness, perhaps I should say that I have absolutely nothing to gain by this writing; it is done honestly and spontaneously.

The title is: "Wild Animal Stamp Primer," illustrated from photographs taken in the New York Zoological Park. The Primer stands as the realization of an idea of Mr. H. R. Mitchell, manager of Privileges of the Park, and was prepared and copyrighted (November, 1916) by him. The fifty, natural colored pictures are by Mr. Elwin R. Sanborn, the official photographer of the Society, whose work needs no introduction. The foreword is written by Dr. William T. Hornaday. The Primer is composed of fifty short stories, many written in a personal, confidential letter-form, and is well fitted to serve as a text-book. It is primarily for children but "grown ups" will enjoy it, for the stories are well written and contain bits of information not easily to be gleaned.

Each story deals with an animal or bird, giving the chief habits and characteristics, correcting popular but false beliefs regarding it, with little sidelights and "secrets" concerning the particular specimen. Heading or footing each is a space in which the picture of the animal written about is to be pasted. The pictures, or stamps, go with the book in a sheet, ready gummed and perforated;

and on the back of each there is a little additional information. Tiny pen and ink drawings with each story give the book an attractive feature. The educational possibilities are at once apparent.

Among other things, Dr. Hornaday says in the foreword: "Anyone who writes truthfully about animals, in a language suitable to young people, is sure of an appreciative audience. Every normal and healthy child is born with a natural love for animals, and a desire to know them intimately. Through lack of opportunity that interest may not develop with the lapse of time, and in the adult it may finally become so dormant as to seem absent.

"The time is rapidly passing wherein to know a wild creature is to desire to 'kill it.' The desire is an inheritance from savagery. Boys and girls of today are more anxious to *know* the wild creatures. A dead animal quickly ceases to be interesting. The most wonderful thing about any animal is its mind, and its modes of life—how it travels, eats, drinks, sleeps, fights and hides from enemies. Every wild creature represents a collection of animal stories. To know these animals in their haunts is to know also a great deal of the geography of the world, and much of its climates, soils and plants.

"The chief object of the New York Zoological Society is to bring to the millions fine representatives of the interesting wild creatures which can not be seen by all in their haunts. The pictures and descriptions set forth in this volume are intended to convey truthful impressions of the most interesting animals of the Zoological Park collection.

G. T. K. N.





DR. ELLIOT R. DOWNING

## Notes from Correspondents

Miss Myrtle Boice who has charge of the Nature-study in the Ethical School in New York City writes:

"School opened yesterday and now we are in full swing. We are doing some work with the stars, etc., winter bird work in the park, also trees in winter."

Miss Adeline Thurston who has charge of the nature-study in the New Paltz, N. Y., normal school, writes:

"My work is delightful here. Just now the pupils are most interested in establishing feeding stations for the winter birds at their homes and in the fields and woods. I have organized groups of boys to maintain the more distant stations. It is a real pleasure to see the happiness of the girls when the chickadees and downies accept their hospitality. The children have had great fun in trimming a Christmas tree for the birds which they will put on the campus tomorrow. The tree is very gay with strings of nuts, crackers and popcorn and pieces of suet.

"What do you think? We have hepaticas in blossom in our moss jars and the arbutus buds look as if they soon would be in bloom. The children have taken a great pride in making terraria and aquaria for their grade rooms this fall. The students are growing hyacinths and narcissus in their rooms this year. O, we have just been doing lots of nice things this fall."

---

## The Texas Farmers Seek to Save the Mourning Dove

When farmers stand firm, legislators must give way. That is exemplified in our history over and over. There comes to us from the Texas Farmers' Congress, held at College Station, July, resolutions remonstrating against the change in the law, making open season for hunting mourning doves to begin September first instead of November first. There is a ring of firmness and warning in these resolutions and the legislatures had better listen to the "wind whistling in the trees." The resolutions are embodied in a Bulletin No. 67 from the University of Texas, Department of Extension on the Mourning Dove by W. S. Taylor, Professor of Agricultural Extension. It is an admirable bulletin from every point of view and ought to save this attractive bird from extinction.

## COMING

Three special numbers of the Nature-Study Review.

March—ANIMAL NUMBER

April—WILD FLOWER NUMBER

May—BIRD NUMBER

Order your extra copies in advance.

Single copies 15c each

Ten or more 12c each

Address **THE NATURE-STUDY REVIEW**  
ITHACA, N. Y.

# American Fern Journal

**Official Organ of the American Fern Society**

Issued quarterly: Subscription, ninety cents per year.

Includes articles of both technical and popular interest with illustrations.

Editor, **R. C. Benedict**, High School of Commerce, N. Y. City.

Business Manager, **E. J. Winslow**, Lasell Seminary, Auburndale, Mass.

## *The Guide to Nature*

Edited by **EDWARD F. BIGELOW**

A Monthly Magazine from the Naturalist's Point of View.

An interchange of observations by students  
and lovers of nature.

*Nature is good in the school, because it is good  
anywhere for all people.*

Subscription \$1 a year

Four months' trial 25c.

Single copy 10c.

**THE AGASSIZ ASSOCIATION**  
**ARCADIA**

**SOUND BEACH**

:

:

**CONNECTICUT**

Kindly mention The Nature-Study Review when replying to advertisements



# THE NATURE-STUDY REVIEW

VOL. 13

MARCH, 1917

No. 3

## The White Rat as a Pet

H. D. BAILEY

Professor of Biology, Muhlenberg College  
With illustrations by the Author

The little boys in the accompanying photographs have had many animal pets, but the one they loved most—and it is not improper to use the word love in this connection—was the white rat shown in the views.

Happy was the day when they obtained this beautiful animal, and happy were all of the days, the days of play and companionship, that they spent with it. There are persons, I suppose, who doubt that a rat can be a companion to a human being, but let such persons argue the matter with the little boys pictured; the latter will soon convince them that their doubts are unwarranted, and, moreover, will tell them a number of very surprising facts about rats.

They will show them, for one thing, that rats, and particularly white rats, are not the dangerous and repulsive creatures that most people believe them to be. "Why, you don't know anything about rats," William, the older lad, will say frankly, when he detects the falseness and injustice of any statement made about his pet. "Here, I'll show you one." And he will go to the box and get his pet.

"Watch out, lad, it will bite you," the observer may say.

"No it won't. White rats don't bite," the child will answer.

"But you shouldn't let it crawl up so close to your face. It might hurt you sometime."

"Oh, no. It won't hurt anybody. Now watch it crawl in my pocket. See, there! Now watch it peep out."

"But it may bite you, William. You can't trust a rat."

"I'm not afraid. Why, I played with it hundreds of times. It likes to play. See here!"

And he will put the rat on the floor, and go to the other side of the room and utter a peculiar call note. The rat will run over to



William

him and spring up on his hands.

"It knows me," he will exclaim.

"It comes whenever I call it and follows me around, sometimes all the way up-stairs."

"Yes," the observer will conclude, after a period of observation, "It does like you, that's certain. And it likes to play. But it is a rat. Rats are dirty animals, William."

"Well, I guess they're not. This one washes

itself as clean as anybody. And we clean its cage out every day."

"But it destroys things about the house, doesn't it?"

"Oh, no. Yes—it did once. One day it got out of its box, while we were away, and crept into the kitchen, and then upstairs. When we got home, it had eaten holes in a table cloth and in some white kid gloves. But they don't do that often."

"But it would eat meat and apples and other things if it found them, wouldn't it?"

"Sure, but other animals would do that, too, wouldn't they? We don't keep it in the house, anyway; we keep it in the play-house. Come out and I'll show you its run-way."

William delights to show his friends his rat's run-way. This

consists of strips of wood, toy ladders, clothes props and a chair, all joined together as shown in the diagram. It was constructed as the result of a discovery made by the lad one day while he was feeding his pet. He brought it some scraps of apple, and, for amusement, placed them on top of its cage. The rat, smelling the apple, tried to get up to it. It had difficulty in crawling over the edge of the cage but finally succeeded, and then noticing a number of pieces of apple, seized one of them, and dragged it to the cage below. Immediately it returned for another piece.

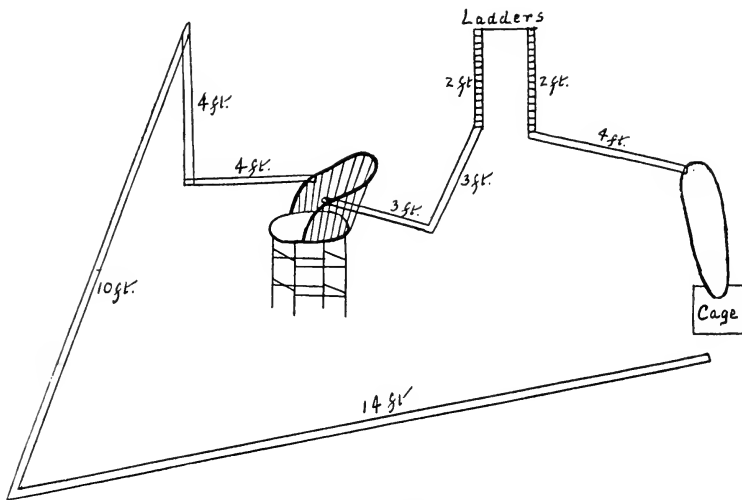

The Run-way

By making repeated trips—and it risked a fall each time it did so—it cleared the box of food.

William watched it closely. Upon its last return, finding no food on the box, the rat stood on its hind legs, sniffed of the air, and looked appealingly toward the lad. The latter watched it for awhile and then ran to the cellar for another apple. When he returned the rat was in its box, eating, but hearing someone about, climbed up on top of the box again. Then a happy thought came to the lad. In the corner of the room stood an ironing board; getting this, he placed one end of it on the top of the cage and the other end on a chair; then he put a handful of apple chips on the farther end of the board.

The rat, standing on the edge of the box, sniffed of the air

for a few moments, and then cautiously ventured on the board. It crept up with jerky movements, a few steps at a time, until it reached the top, where it grasped a piece of apple, and, turning about, carefully made its way down to the box again. In a few moments it returned. This time it ran up the board at full speed, never pausing until it reached the top, and there seized another piece of apple. In a few minutes it transported all of the apple to the cage.

William was delighted and set about to secure additional boards to lengthen the run-way. The rat, lured on by its desire for food, lent itself to his schemes readily, and shortly the run-way grew to the size shown in the diagram. It was then over forty feet long and quite impassable in several places. Two ladders, each two feet in length, stood upright, and the rodent had to ascend the one and descend the other each time it passed along the route. A four foot strip of wood stood upright also and necessitated ascent and descent each time a complete trip was made. The passage up over the back of the chair was not as easy as it might seem from the diagram; it demanded a flying start, a trick the rodent soon learned, and, once learned, did not forget; descent here required skilful bracing with the legs. The end of the run-way was about five inches from the cage.

It seems inconceivable that an animal would repeatedly make this arduous journey for the sake of obtaining small pieces of food. Yet the rat did this for hours at a time. One day the writer watched it make sixty-seven successive trips; he does not know how often it might have gone the route had a thorough test been made—certainly many more times than it did, for it showed no signs of tiring on the last trip observed.

Some of the food particles placed on the run-way were very large, so large, in fact, that the rat had to employ its claws as well as its jaws in transporting them. But it never faltered. The journey up and down the ladders was perilous, but only once did it fail to drag its load over them, and that was when the load was so large and heavy that it could not possibly cling fast to it. Straining, pulling, tugging, losing its balance and regaining it again, digging its nails deep into the wood of its support, sometimes clinging with its tail, it transported load after load until it had filled its cage to overflowing. Even then it did not stop, but kept adding to the pile outside the door.

To William it was remarkable that an animal would make such a roundabout journey to accomplish a purpose that it might have attained by taking a leap of five inches from the run-way to the cage. "Why don't it look and see where it is?" he would ask repeatedly. I answered his question as best I could and then suggested that he place the end of the run-way still closer to the cage. He put it but four inches away. The rat failed to notice the change. Then he placed it two inches away. This time the spell of the long trip over the sticks and ladders was broken, and the rat, pausing for a moment, as if wondering whether it could really be true, hopped briskly to its cage and in three seconds hopped back again. The word excitement scarcely describes its action just at this time; it seemed overjoyed. I suppose it was cruel to continue experimentation at this juncture, but in a few moments I suggested to William that he draw the run-way to one side, and find out if the rat would resume the long journey again. He did so. The rodent stood at the edge of the cage for a while and then, without further ado, turned around, and ran over toward the ironing board. Five minutes later the long trips over the run-way were in full swing again.

The deepest iragedy that ever came to William and his little brother came to them about three months after the above experiments were made. One day they went to get their pet and found that it was gone. The door of its cage was wide open, and the floor about the cage was splashed with blood. Tufts of silky white fur, much like that of the rodent, were scattered about everywhere, and a number of scratches on the door of the cage evidenced a struggle that had taken place a short while before. The little boys, realizing that their pet had been wounded and probably killed, cried bitterly. No trace of the assassin or of the rat could be found anywhere, although a search was kept up all afternoon. Later in the day, however, a large gray cat appeared on the lawn, and stealthily made its way toward the play-house. Then everything became clear. In the absence of the children, the cat had evidently entered the play-house, and, seeing the rat, had clawed its cage-door open, and then had killed it.

"Why did it do it?" Junior, the younger child, sobbed piteously. I tried to explain to him that the cat was not really responsible for the grief that its act had caused. But I doubt if the little fellow understood me.

The white rat is an albino. Over in west-central Africa there is a race of men, of negro extraction, whose hair and skins are white and whose eyes are of deep pink color. Long ago the Portuguese, observing these people, called them albinos, a name referring to their white color. We now know that albinism is a common occurrence in both the plant and animal kingdoms. By isolating albino individuals and breeding them together we may obtain albino races. Thus have arisen white blackberries, white raspberries, white currants and white strawberries. Albino races among animals are even more numerous; we have them in rabbits, mice, rats, guinea-pigs, sheep, goats, cattle, dogs, cats, horses and many others.

Albinism is due to the absence of pigment or coloring matter in tissues that normally possess them—in skin, hair and eyes, for example. Just what causes some individuals of a species to lack pigment, and other individuals to possess it, we do not fully understand. The Laboratory for Experimental Evolution, maintained by the Carnegie Institution at Cold Spring Harbor, L. I., is working on this problem at the present time and hopes to solve it shortly. Its workers have already arrived at a partial solution. They tell us that there is a correlation between new cases of albinism and consanguinity, and that albinos, when mated together, always produce albinos. Albino rats, for instance, mating with each other, produce albino young only. When an albino rat mates with a black or brown rat, however, it produces both albinos and blacks or browns, in the proportion of about half albinos and half blacks or browns.

The white rat shown in the views had pink eyes, a character possessed by most albinos. The cause of this color is very simple, although a mystery to most persons. The iris and retina of eyes are richly supplied with blood vessels. Now, in normal eyes, these blood vessels are concealed by pigment and so are never seen, but in albino eyes, which lack this pigment, they are exposed to view, and give the eyes a deep-pink color. We are looking at a complex web of minute blood tubes when we look at a white rat's eye.

Pink eyes have advantages and disadvantages. In sunlight, they are easily blinded, due to their transparency and inability to withstand bright rays of light. But at night time they more than make up for this deficiency; then they become powerful,

far more powerful than our own eyes, and give their possessor advantages over most other nocturnal animals. The writer well remembers the actions of the albino rat pictured. During the day it was not very active, making little effort to get away from a person handling it; but at night it became another creature. Then it would speed off whenever given opportunity, and avoid capture as long as it could do so. Running, jumping, dodging, twisting its head about and flashing its blood-red eyes, like balls of fire, upon its pursuer, it would outrun, outdodge and invariably outwit him. To catch it was an accomplishment well worth while, as William and his little brother always thought, and many was the good romp that they had with it.

White rats are not very popular as pets at the present time.

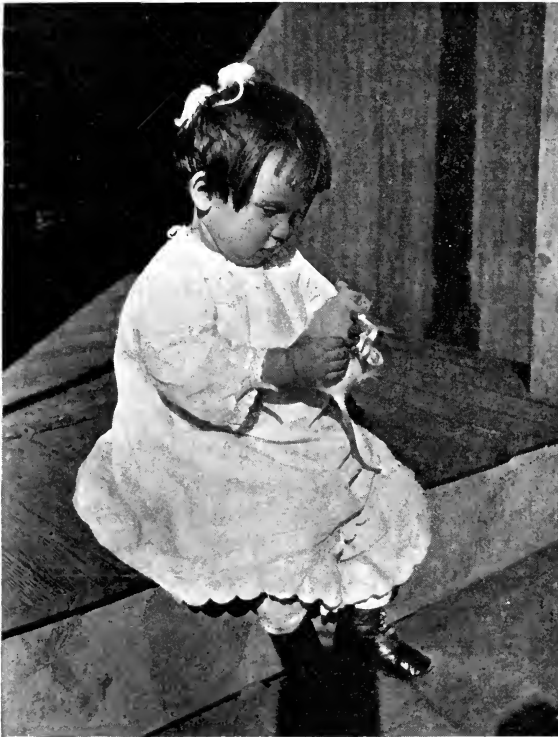

Junior

This is partly due to the aversion that people have for animals that resemble the so-called house-rat, and partly to the lack of knowledge concerning the nature and habits of white rats. As knowledge of this kind increases, respectability and favor will be bestowed upon white rats, and eventually these animals will attain the

popularity that they deserve. Comparatively few of our animal pets are so kind and gentle, so beautiful and so interesting.

## Nature-Study and Humaneness

GUY A. BAILEY

Professor of Biology and Nature-Study, State Normal School, Geneseo, N. Y.

What may one naturally expect of a boy or girl after having followed an average course in Nature-Study for eight years? This means a course where some time is devoted to the subject either directly under the name nature-study or in connection with other subjects like geography and in general topics that may be discussed in connection with boy scout's work, bird clubs and the like.

It seems to me that so far as the pupil's study of mammals is concerned that there are certain facts that should be studied and certain points of view that should be emphasized. The point of view is more important to society in my judgment than the facts studied.

Among the facts that he should have in mind are the general adaptive features of mammals, such as the feet and teeth of squirrels, the tail of the muskrat, the feet of the mole together with the small eyes, etc.—how these structures are serviceable to the animal? Of course the animals to be studied are those that the boy or girl knows about. In some cases domestic animals may be the only ones available and those will do just as well as long as the adaptation of parts is kept in mind.

The facts about how the young are cared for and where they are cared for. For example if foxes are familiar, where they care for the young and what time of year the young are born. Where the young squirrels are kept by the parents and how many litters they produce in a season, how many in a litter? Where do the rabbits keep their young and how many in a litter? How many litters may they produce in a year and in what months are they born? Information may come from those who know of the domesticated rabbits as well as the wild ones. In general facts about the life history of such animals as come under their observation whether domestic or wild.

For a third class of facts I would recommend those that have to do with the animals behavior towards our northern winter. As we know some hibernate. What ones hibernate and where do they hibernate and for how long? Can you show how the animal would fail if he attempted to survive our winter season by



remaining active? For example what would happen to a woodchuck if he attempted to get food when the snow was on the ground? What food would be available? Several questions to bring out the point that what the animal has done is the best for that particular animal. Chipmunks, and some kinds of bats hibernate also.

Grey squirrels have been known to migrate from one region where food was scarce to regions where it was plentiful, even swimming lakes and rivers. Few of our mammals are able to migrate like the birds when the food supply becomes reduced. Some animals like the weasel, mink and fox are active all winter. The weasel having white fur in winter and brown fur in summer. How does this give the weasel an advantage for survival? Skunks are dormant for short periods. What advantage is even a short period of hibernation to the skunk? In general a study of local animals to the end that pupils may know where they are and what they do during the winter season.

For a fourth class of facts to be considered I would prefer the study of the economic side of the mammals. From personal observations and reliable authority classify the mammals into helpful and harmful groups.

Some care and considerable study is needed before an intelligent classification can be made. The food of the animal for a year—month by month—is necessary before we are sure where they belong. The fact that an animal eats small chickens at rare intervals need not be proof that the animal is harmful. For example the skunk does this rarely. But the most of the food of the skunk is insects and mice. If one skunk eats chickens it is by no means true that all do. If one skunk is guilty it does not mean that the skunk family should be put down as harmful. The whole total of the work of skunks is beneficial rather than harmful. Some care should be exercised in forming opinions either in favor of the animal or against it.

Then there is the esthetic side of animal study. It is the side that has no debit or credit. It is far removed from the "cash and comfort" side of our nature. Why is it that in some communities there may be seen squirrels in the tree tops and the parks? Boys and girls, men and women carry peanuts to feed the grey squirrels. People stop to watch them eat the nut or carry it away to be stored elsewhere. Why do people do that? What is the point of view

of the person who feeds the squirrels? What is the reaction on the community that tolerates squirrels within its borders? I leave that to any one who has lived in such a community. I know of no factor in nature-study more potent than the object lesson of squirrels running through the streets and on to the porches of the houses where these boys and girls are growing up. It takes several generations to get the squirrel proposition working right. There are at first complaints when they take fruit from the trees and run through the house early in the morning but there comes a time when people are willing to tolerate them just to see them about. Squirrels at large are so much more interesting than the caged ones. They are real. The delight of seeing the young ones come out and master the trick of sitting up on their hind legs for the first few times is worth waiting for. The whole story of the squirrel is interesting to any one whether he is a biologist, animal psychologist or an average observer. Few boys that are raised with the squirrels have the heart to go out and kill them in the fall. More than that they are out of sympathy with the whole slaughter movement of the hunting fraternity. If every chronic hunter could have had a dose of close-up squirrel acquaintancy with a brood of young squirrels and had fed them through a winter and had them eat from his shoulder or go hunting through his pockets for nuts there would be little need of a law to protect them.

After all our nature-study work absolutely fails if we bring up the boys so that they see no more in a squirrel than a pot-pie or a day's outing for his little bit of flesh. May we train him away from the ancient, primeval hunter towards the man who can see beauty in the living form and not hanker after the taste of the blood.



"Because of his tendency to grab things quickly one had to be careful in allowing him to take food from the hand." Because of this care, Mr. Knight seems to have only one hand.

## De Sachet, A Pet Skunk

HARRY H. KNIGHT

Investigator in Entomology—Cornell University

My acquaintance with Sachet began on the 15th of July when we chanced to meet on the edge of a woodland. It was doubtless not far distant from the family den from whence he had strayed in search of food. Having heard that young skunks make interesting pets I quickly decided that here was my chance to learn something of this little known animal. Before he could get out of sight I had him safely caught in my insect net. He was frightened but emitted no odor so I let him crawl into the darkness under my coat. Sachet was perhaps six weeks old at the time I found him and after keeping him two weeks, I removed his scent glands. This was a fairly simple operation and was performed while the animal was under the influence of ether. After this the prefix "De" was added to his name and I was able to rear my pet without fear of disagreeable odors. De Sachet soon learned to drink milk from a dish but only after many attempts spent in digging in the dish with front feet a performance followed by licking his paws dry of the milk. It appeared to be an instinctive habit with the animal that to acquire food he must first dig

for it. However, within a week he began to drink milk after the manner of a house cat.

One activity that furnished much amusement while he was still small was to give him an egg on the grassy lawn. He knew the egg contained food but all efforts to crush the shell were futile and this caused him much displeasure; his game of egg-ball afforded him more entertainment than enjoyment.

It is well known that skunks dig up lawns in search of white grubs but the manner in which these morsels are located was interesting to see. The front feet were used to part the grass and scratch the earth along a narrow path while the animal slowly backed up keeping his nose held close to the fresh earth thus exposed. In this manner three or four feet might be uncovered before finding the right spot to dig.

De Sachet's most comical activity was barbering woolly-bear caterpillars, for evidently skunks are fond of all caterpillars, but do not like their dainty morsel fur coated. When he found one of these little hurried travellers, he would seize it and knead it under his front paws, which he moved with great rapidity. Meanwhile he would look around as if interested in the scenery, like a boy nonchalantly twirling his thumbs, apparently giving no attention to his whirling paws or the unfortunate caterpillar, which was rolled over and over at a rate that must have made it die of dizziness rather than because it was crushed. One day we placed De Sachet on a newspaper while he rolled a caterpillar, and when he got through, the poor shorn insect was still squirming, though as bare as an earthworm; and the amount of hair and fuzz of various lengths left on the newspaper gave us a new respect for the furs worn by the woolly-bear. Sometimes De Sachet would make a slip and the caterpillar would be flung a few inches to one side, but would quickly be recovered. The closeness of the shave he gave his victims depended upon the degree of his hunger.

I was much surprised one afternoon when De Sachet found a bumblebee's nest at the foot of a fence post where he had been tied. What fears I had for my pet were shortly dispelled when he began to dig into the nest and seize the bees with avidity. The contents of the nest kept him busy for some time but later other bees returned to attack the intruder from the rear. As a safeguard De Sachet kept his tail waving over his back and it was this

the buzzing bees usually struck first. The buzz of a bee in the tangle of fur called his immediate attention and the rapidity and swiftness with which paws and teeth responded to the rescue was amazing. At times he would drop over on one side that the bee might try to alight on a spot where the paws could be more easily brought into play. After the nest was well cleared out the returning stragglers were caught one by one, being snapped up quickly as they would alight to sting. The animal's head was always turned toward the sound and many bees appeared to light on his nose only to be met by a lightning snap of teeth. The skunk's eyesight is very poor, at least in the day time, and thus the animal depends largely on smell and sound for seizing insects. From this first nest De Sachet was seen to eat no less than 27 bees. He appeared to get stung twice, once on the jaw and again on the shoulder, which was not bad considering it was his first experience with bumblebees. At a later date he was given opportunity to attack a very large nest where he caught and ate no less than 48 bees before his appetite failed, and this time without being stung once. He refused to go near the bees once his hunger was appeased.

Grasshoppers were eaten with avidity and appeared to be a favorite food. He appeared never to see insects but would pounce upon them with lightning speed once they were located by smell. He also would eat quantities of a most common millipede usually found beneath leaves in damp places and occasionally in potato fields. Because of his tendency to grab things quickly one had to be careful in allowing him to take food from the hand. This was especially true of insect food. On two occasions De Sachet was soundly boxed for grabbing a finger in place of some meat held out for him. A day later he made the same mistake, and realizing this he turned away with a whining whistle, at the same time backing up toward me apparently expecting to be punished. It was so comical I did not have the heart to touch him.

The skunk has a quick temper and may be fierce in the face of an enemy or when sufficiently hungry. When De Sachet could smell meat which was withheld it was not safe to stroke him. He was all business then and gave vent to his impatience in anger. If he were allowed to seize a large piece of meat while one held him firm he gave forth a peculiar whistling sound combined with snorting and blowing, which was undoubtedly meant

to frighten one into turning him loose. I thought to teach him to go into my pockets for food but found that impossible for he always took the shortest route by trying to tear through the cloth with his teeth. It was then with some difficulty that he was made to release his hold on the pocket. He did learn to sit up for food and even hold that position while disposing of a small piece, doing this apparently to save the trouble of making the effort to sit up again.

As De Sachet grew older the instinctive shyness of the young kitten was lost and he came eagerly toward me in expectation of food. After being well fed he was always ready for a playful romp. He would seize my hand with teeth and feet, clinging to it and clawing it in much the same manner of a playful kitten. This was varied by jumping back three or four feet and going through all the actions employed in fighting a real enemy, such as raising the tail to throw scent, dancing up and down stiff legged with tail held high in the air, then forward in hops. This was a most comical performance and one always enjoyed by both parties.

In order to give De Sachet as much freedom as possible a small cat collar was placed about his neck and thus he was leashed to the end of a light chain. The chain was always tied from a point overhead to prevent dragging as much as possible. At night he was kept in an old feed bin and later with a change of residence, a large box was substituted. During October and November he grew exceedingly fat, was always hungry and in fact ate as much as most dogs. As cold weather came on he gave evidence of needing more bedding and remained curled up most of the time; head and tail being tucked under so that all one could see was a round black ball of fur with two small white stripes at one point to indicate the head end. If I disturbed him after he had spent a cold night in this hibernating position, I was greeted by a sleepy-eyed, much mussed up and damp, matted black head, caused by breathing in such a restricted position.

De Sachet took his departure into a hostile world on the night of December fifth, having slipped his collar which had been loosened to accommodate his growing size. He was seen but once afterward but has with the coming of continued cold doubtless settled into more extended hibernation under some building on the Cornell campus.

## A Reading of the Nature-Study Barometer

LOUISE CONNOLLY  
Of the Newark, N. J. Museum

An address delivered before the American Nature-Study Society, Dec. 27, 1916

When I was young, I knew an old farmer in Virginia, who was a very poor farmer, but who struck all the city folks who heard him talk as "extremely intelligent for a farmer."

There were three reasons for his being a farmer. First, his father had been a farmer. That will be accepted by all those advocates of vocational education who want to teach the principles of metallurgy to the children of a mining region, and the applications of trade discount into the public schools near Wall Street. Second, he owned a farm. That will appeal to those who give their children music lessons because they own a piano. And third, he fell in love the year before his father died. We all know about that. If you fall seriously in love in your sophomore year, you decide that you don't need a college education, and you go into your uncle's commission house. If in your senior year, you forego the law and accept a position as principal of a country school.

This farmer one day drove a sorrel mare of thirteen summers that he had raised from a colt to the county court house and put up the mare at a livery. And he had to wait that night until everyone else had gone, and take the horse that was left, because he couldn't identify his own mare.

Once I taught across the hall from a graduate of Yincevard and when he went off to be married I took his class for a week, and put a substitute into mine. That young A.B. had had his mental arithmetic taken apart and rebound with interleaves containing all the problems worked out by his college chum, because he couldn't do them himself.

These are not irrelevant, fancy sketches; they bear directly on our subject.

Within the schools there are three foes of nature-study—the school officials, the teachers, and the janitors.

The janitors are justified; nature-study is the natural foe of tidiness—not to say cleanliness.

The teachers have more than one reason for their enmity. Many of them were asked in the high school their goal in life,

and on designating the profession, were advised to take a classical course. Whether the high school principal gave the advice with the approbation of the normal school principal is a question. But the result is evident. Many of them were born with the idiosyncracies of my farmer friend. No skillful incitement to interest, no well developed lesson, no generalization, no formulation, no application, no drill could have made them close observers of natural phenomena or could have brought them near to nature's heart with anything but a literary or philosophic appreciation of her influences.

There is, in many school systems, nature-study at the bottom, and science at the top, but a vacuum in the middle. The kindergarten and first grade have much work with plants and birds, and insects, and domestic animals; the second grade has an appreciable amount; there is a diminution in grade three, and a trace in grade four. But the grammar grades are bare of everything but the deleterious effects of alcohol and the rotation and denudation of the earth. And this is largely due to the lack of scientific knowledge among teachers.

But the chief reason of the teacher's reluctance is her common sense. She has in every class pupils like the young college graduate. He has gone now where his ignorance of mathematics can do no harm. For the same reason which causes heated air to rise, he has become a superintendent. And now he hires a business college girl at ten dollars a week to calculate for him. But every teacher knows how he got his degree. He has the intellectual maturity, so far as mathematics go, of a Tierra del Fuegian, but he has a diploma. And he got it by bluffing, by cheating, by remembering, and by taking chances. His neighbors from the third grade up, all boosted him with kindly common sense, and his professors overlooked errors, ignored audible promptings, gave credit for vicarious class efforts, and made out fool-proof questions—all as palliatives for the preposterous conditions which systematizations of the unsystematizable produce.

Now a teacher who has to teach Newton's principles to a Tierra del Fuegian, Adam Smith's economics to a direct descendant of Ashurbanipal, Myron's sculpture to a Hungarian peasant, and the morality of Jesus to congenital Hotentots doesn't want to add the interpretation of Thoreau and Theodore Gill to the



children of Syrian Jews. They may accept the virus or they may remain immune. And her innate maternal instinct, entirely wrong as all instincts are when conditions change, will cause her to devote all her time to the hopeless cases, to the infinite boredom of such pupils as have native ability, and to her own nervous undoing. She does this now in thirteen subjects, and hopes to be spared a similar desecration of nature.

The school official is to blame. So long as he demands certain visible results he will get certain invisible concomitants. Just so soon as he gets nature graded and distributed, so that he can examine on it for promotion will the teacher show her usual inventive ability in making of the subject a dead and deadening drill. And if he spares nature, just so long as he examines and promotes on other subjects nature will be neglected.

Hence our courses of study are full of high sounding phrases about the intellectual and moral values of the study of nature, and our class rooms are too often devoid of its practice.

There are, outside the school, two agencies which are ready to cooperate with the nature study propaganda, and another which has great potentialities for usefulness. The two agencies already at work, and likely to do much more as soon as mutual confidence becomes more general, are the museums and agencies such as park commissions, zoos and aquariums, botanic gardens, and the like. The agency not yet involved, but ready for very valuable usefulness, is the grange.

At the last meeting of the American Museum Association there was one session devoted to this subject, but no session was devoid of it. It is the great center of museum interest everywhere. My pamphlet on the Educational Value of Museums published by the Newark Museum, finds response from all parts of Europe, even amid the present convulsions. And, though only two years old, it is past history—so fast are museum activities among children increasing. This is true of both Art and Science museums, but the correlations of science with the work of the schools are the more varied.

This movement has not always—indeed has not preponderatingly—begun with the schools. Would that it were so. The proper sequence is for the schools to desire material for their activities, and for the museums to respond. The museum too often has to create its market.

A few years ago a certain museum spent several thousand dollars in putting up an industrial exhibit that involved much of science, of mechanics, of geography, history and art, directly related to the work of the schools. One of the superintendents of the schools said, in refusing to let the pupils come as a part of their school work, "We have constantly to defend our schools against the well-meant efforts of people who would distract them from their fundamental function of teaching reading, writing, and arithmetic."

But at least the janitor's resistance can be largely overcome by museum cooperations. A case of birds, lent by the New York Museum is compact and clean. The teachers of Brooklyn and Boston, doing their science work in the parks around their children's museums, make no litter. Our specimens of minerals, a case for each child, and a larger one for the teacher, accompanied by neatly mounted related pictures, and with a half-dozen books on the same subject from the library in which our museum is housed, incommode no one.

The teacher who does not know the details of her subject is succored by the museum. One hardly expects the museum docent to do the actual teaching, but in small places this really happens. One of Miss Griffin's most telling stories is of her talk to the teachers, at Saint Johnsbury, on how to familiarize their pupils with birds. She noticed on the faces of her audience expressions of agony, and she paused, enlightened. "Perhaps," said she, "you would like me to give some of these lessons for you." There was a rustle, and then acclaim—"Oh, we would, certainly we would." And she did—until she was called by Boston to a larger field.

If in your own homes you have not help from out-of-door institutions, you should investigate what is being done by Mr. Madison, who draws upon the Roger Williams Park in Providence, or by the Bronx Botanical Gardens and the New York Aquarium.

What we in Newark can do for the schools in the way of lending is but a drop in the bucket to what is asked of us, and yet the asking is merely due to the sporadic interest of individuals. Were the course on paper suddenly to be vivified into reality by power from above, we should be entirely swamped. In any centre it seems wise for the school authorities who are in earnest to push the double service, the schools providing the teaching, and the

museums and other supplementary educational agencies the material, and to go slow—to let their next point of attack be known by the museums before introducing new features into the schools.

And it is of the utmost importance that both organizations should educate their public by wise publicity as they go along. I have watched this movement, which has been glacial, rather than torrential in its pace, for thirty odd years and I have seen the best cooperations in the world debouch into a morass for the lack of this feature. Fifteen or twenty years ago Superintendent Powell of Washington, through the good offices and connections of his brother, Major Powell of the Geologic Survey, had all the scientific corps of the Government in the service of the Washington schools. The teachers were taken on excursions and instructed in their schools by botanists, geologists, bird-, beast-, and fish-men; the Coast and Geodetic Survey, and the Weather Bureau gave of their best; classes sketched in the parks, visited out-door features and public buildings; and all sorts of things were lent and used. But when a local politician wanted an excuse for attacking Mr. Powell the parents were, at the most, vaguely sympathetic. A superintendent who thinks children are being diverted from the true aims of education when they are encouraged to see what they look at, feel what they handle, and hear what they listen to is in most places in no danger of losing his position for his views. The old road is still the safe road.

As to the grange, I speak with the diffidence of ignorance, but every grange has, besides the grange master, a grange lecturer—the educational and intellectual leader. And these lecturers belong to a kind of mildly persuasive hierarchy. They hold meetings where they get inspiration and exchange experiences. There are many experiments being made in single localities with rural schools, and from these centers the virus is slowly spreading upward. Were it injected into the arteries, the transformation might be made more rapid. From what I heard at the New Jersey meetings, I can aver that the thing called Domestic Science, closely correlated with the alimentary nature of man, is much cultivated in the grange.

I have now to suggest the two possible ways which it seems to me promise for nature-study best progress in the elementary schools. Neither is entirely new.

Wherever the alternating, or Gary, school is tried there is a

chance to put one or more teachers really interested in the subject, and aiming at a definite performance, in charge of nature-study. Of course where the alternating corps has to be obtained from the faculty of the former school, and where the former school was steeped in sin, that will make of nature-study a farce. And, indeed, with great freedom to select, the Gary school will find a dearth of well prepared applicants. Normal pupils usually get a limited range of nature work, and college science graduates rarely have pedagogy or power of class control.

The other suggestion is a science supervisor, not only belonging to the school system, but connected also with the local museum, or park system, or science department of the state or city college or normal school. Such schemes have been tried, I believe. St. Louis subsumes the museum under the school system; Buffalo pays a nominal price for science delivered from outside. New York refuses science in toto, and takes it piecemeal, at the hands of outside agencies. Each locality has its own conditions. My belief is that, all other things being equal, the supervisor should be of the schools; should do more about teaching than about science, for if teaching methods were good science could easily be taught; should get her scientific pabulum and material from the best sources in the locality, by some definite and even legal relation rather than by courtesy, and should be well provided with two things—means of conveyance for herself and her materials, and opportunity for advertisement and public commendation of her functions and results. When using public funds to do for the children of a community what was not done for their parents in their young days, never fail to let your right hand know what your left hand does, and secure public encomiums for each apparently doubtful feature of the work. Do not let the townfolks know that there is a chicken in the kindergarten and a turtle in the cloak room, that the first grade is studying pumpkins and the fifth grade junketing in the fields during school hours, *through your critics first*. When the accusation comes, see to it that the judges "knowed it afore."

So, in time, may the children of our country regain their lost heritage which too many of us feel has been sold to the academic ideal at a great price.

## To A Wood-Rat

(Whose home was destroyed by a class in Zoology)

JAMES LEO DUFF

Och, it pulls at me heart  
to see you afflicted,  
You with the great  
sobbin' eyes of ye there;  
Could the Irish stand by  
to see one evicted  
An' say, "I don't care?"

You that have labored  
your home to be earnin',  
You've toiled in the buildin'  
be day an' be night.  
Now they've pulled it apart  
for the sake of their learnin'—  
God send thim light!

*Reprinted by permission from "A Stanford Book of Verse" by the English Club of Stanford University.*

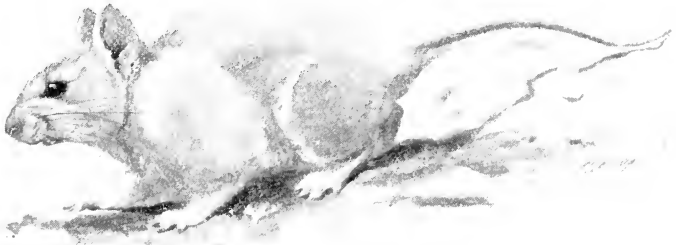

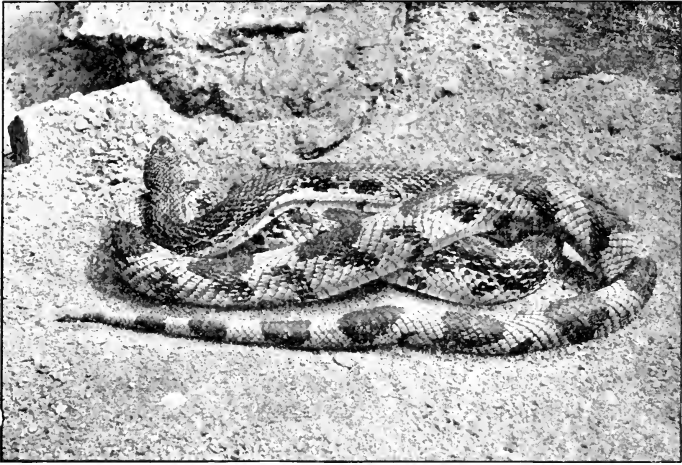

## A Pet Pine Snake on a Wisconsin Farm

KARL P. SCHMIDT

American Museum of Natural History, New York City

A big yellow snake or two hanging over a roadside fence, victims of the snake killing zeal prevalent in rural communities, was not many years ago a common sight in the farming country of our Middle West. The Pine Snake or Bull Snake (*Pityophis catenifer sayi*) is most likely to meet this unmerited fate, for snakes of this species frequent especially the hay and grain fields in search of the destructive short-tailed field mice, and so meet their own destruction at the hands of the farmer or the farmer's boy. Although the sight becomes yearly less common, the increasing rarity is not, I fear, an evidence of increasing intelligence among farmers, but of the alarming decrease in numbers of this species, one of the largest and handsomest as well as agriculturally most useful of North American snakes.

As a part of a campaign against the indiscriminate slaughter of snakes in general, it has been a yearly practice on our Wisconsin farm to keep a snake or two caged on the back porch for a time in summer, to demonstrate their harmlessness to the neighbors. Never until last summer, however, did we have a Pine Snake (always our favorite species) that would feed in captivity. Our last year's pet proved interesting in more ways than one.

Early in July I caught a specimen of this species about three and a half feet long, which I judged from its stockiness to be a female with eggs. It did not offer the vigorous resistance to capture that the larger ones usually make, and when placed in our glass fronted cage, instead of becoming sluggish and "tame" in a day or two, in accordance with our experience of Pine Snakes, this one continually tried to escape, pushing against the glass until its nose was quite mangled. This continued day after day, and we would surely have let it go in pity had we not hoped to see the egg laying process.

An especial joy of ours is the intense interest in snakes of those who claim to be most afraid of them. It was while two young women of the neighborhood were watching that our pet decided to deposit her eggs, which seemed to them even more scandalous conduct on the part of the snake than was ours in keeping such animals. But nothing could move them from the snake cage while the egg laying continued, a matter of some hours.

The first eggs were laid at intervals of about ten minutes, the interval gradually increasing so that it took nearly four hours to deposit the entire batch of fifteen. They were about as long as pigeons eggs and about half as broad as long, white, and very sticky, so that they clung together in a mass, about which the mother remained coiled. To our great disappointment the eggs did not develop, and we were unable to follow the life-cycle through as we had hoped.

Before the egg laying our snake had refused food, as is the somewhat unusual custom of snakes with eggs or young, and we did not think of feeding again until we gave up all hope of the development of the eggs. Then, when we offered a live mouse, the result was highly exciting. The snake threw itself on the mouse, grasping it by the shoulder with the jaws, and coiled around it with the middle portion of the body. The body followed the head so quickly that separate motions of striking and constriction could not be distinguished. After a few minutes of constriction, so tight that the mouse's eyes bulged out of their sockets, the hold was released, and the mouse proved to be quite dead. The snake nosed its prey until it found the head, and immediately began the swallowing process. The remarkable mechanism of a snake's jaws whereby unbelievably large objects can be swallowed, is easily observed. First one side, then the other of the separate

lower jaws is moved forward, while the backward pointing teeth of the upper jaw, and of the inactive half of the lower, retain all that is gained. The snake literally draws itself over its food. To our surprise, since we had always supposed that snakes ate only at considerable intervals, and had no experience as to the amount of a single square meal, our Pine Snake cheerfully accepted a second mouse on the next day. We never did succeed in finding its limit, for it ate every mouse we offered it, twenty-one in all, from August 16th to September 7th, an average of nearly one a day. A number of these were young field mice brought in from the hay field, and they were taken directly from the fingers, with no striking or constriction, and swallowed head or tail or back foremost as was convenient. A half grown field mouse seemed to leave some doubt in the snake's mind as to the proper procedure. It struck and grasped the mouse with the jaws as usual, but instead of constricting, simply coiled on top of it, somewhat as the black snakes and racers are said to do. Finding that the prospective dinner made no serious struggle, swallowing was at once begun, without relaxing the hold, so that the mouse went down back first, its head and tail doubled together.

The largest number of mice taken at one time was seven, a full grown short tailed field mouse and six young. The swallowing process occupied from three to four minutes for an adult mouse.

By the last of August the snake's eyes had become very opaque, and the color dull, so that we knew it was preparing to shed its skin. Young field mice were still accepted, but larger ones placed in the box were either left undisturbed, or killed and left uneaten. The fast continued until September 15th, when with a little assistance the old skin was shed, and the eyes were again bright and the new skin brilliant with its yellow and black pattern. Not long after this we gave all our snakes their freedom.

This was by far our most successful experience with a Pine Snake. We may surely hope, and indeed we know, that some at least of our neighbors who saw the feeding, and heard our glowing accounts of a Pine Snake's insatiable appetite for mice, were convinced of the usefulness of at least one species of snake. We had contributed our mite, as an old Scotch relative said, toward "keeling a supersteeshun."



# The Goat—An Appreciation

WILLIAM P. ALEXANDER

Assistant in The Natural History of the Farm Course—Cornell University.



## THE ROCKY MOUNTAIN GOAT

Where the rocky ramparts raise  
Skyward into regions sterile,  
Where the storm at random plays,  
And the heights are fraught with peril;  
Where the falcon sends his note  
Defiant from the cliff a-ringing,  
There the fearless mountain goat  
To his awful path is clinging.

On the crag with ragged face  
Where man has never tried his daring,  
Upward with a daunting pace  
Still the great, white goat is faring;  
For the scanty tuft of grass  
Still he mounts the dizzy fastness,  
Up beyond the clouds that pass  
Below him in a sea of vastness.

On the treeless shelf and crag  
Little knows he of the fearing  
Of the forest hunted stag,  
Anxious eyed, and timid peering;  
Never comes the shaggy bear  
Where the lone height finds him sleeping,  
Never panther from its lair  
Fears he, through the midnight creeping!

One alone to do him wrong,  
Still in mad, foolhardy risking  
Mounts the ramparts, wild and strong  
Up to where the kid is frisking;  
Man, the huntsman, void of sense  
Still the savage blood displaying,  
Revels yet in violence  
And a pleasure finds in slaying!

With the hissing leaden ball,  
Man the pinnacle doth ravage,  
And the mountain goat must fall,  
For the pleasure of the savage;  
Jagged peak that rends the sky  
Lends him not a habitation,  
Where from danger he may fly,  
Or the path of devastation!

Would the old time reigned anew,  
When the golden morn arousing,  
The mountain goat might shake the dew  
From his pelt, and wander, browsing,  
Still secure o'er rugged rift,  
In the haunts of soaring eagle,  
Where the mighty mountains lift  
Their heads in silence, stern and regal!

## THE GOAT IN HISTORY

The goat has been of use to man from the earliest time. Just when or where this animal was subdued and domesticated is not known, but the pages of recorded history, even from the first, have made mention of it in many important connections. The Old Testament, the writings of the ancient Greeks and Egyptians, the records of the Chinese, the Sanskrit scroll, and the Prakrit legend, all make mention of the goat. There was a time when the great men of the earth named their riches in the number of goats they owned; we find traces of this method of rating, even in this country as early as 1640; John Joslyn writing in Massachusetts in that year made this interesting statement, "*He was counted a nobody who had no goats.*" It is of interest also to note that in Spain the Pleiades have from time immemorial been called the Seven Little Goats. Today they are found everywhere on the face of the globe where the climate is suited to their extremely flexible nature, in very hot countries, and in very cold regions as well. Economically, they are in many countries today the most important of all animals. Greece has one-hundred and twenty goats to every hundred of its population, and little wonder when we consider that the yield of perfectly good wholesome milk from these animals is greater than that of the cow, when the goat is measured comparatively. Although this is intended for a discussion of the domesticated goat, it will not be out of place here to say a word or two of some of the wild relatives of this beneficial animal, one of which is found in the United States, the Rocky Mountain Goat (*Oreamnos montanus*). This is the only representative of this great family of quadrupeds, Ungulates, now found in North America in a wild state. It is a noble if not handsome member of its family; it is covered with long white hair that lengthens out on the breast into a flowing "apron"; the shapely eye, straw-yellow in color is set in a fine-cut head that bears a pair of thin, black, curved horns. It is the characteristic manner of carrying the head, generally below the broad shoulders, that inspired the Indians of the mountainous West to name our great white goat, "the little white buffalo." Some writers have spoken of this goat as being extremely stupid and dull, mistaking the confiding fearlessness of the animal for want of intelligent keenness. Another writer though, Mr. Frederick Irland, more ably describes it as being "the most charming and

innocent creature" to be found in the Cascade Mountains.

The hoofs of all goats are particularly well developed for climbing; but in this art the Rocky Mountain Goat excels. He is unbelievably daring and adroit in his passage through the rugged mountain wilds that he inhabits. He seems to risk limb and life itself in every move it makes on the rock barrens, and ice fields that it delights to roam in. Here in the bleak upper world, where only a stiff coarse grass and a hard and almost lifeless lichen is found to sustain these animals, they thrive and are seemingly well protected from beasts of prey; for few or none of the creatures that could devour them are able to follow the treacherous ways that are broad highways for the mountain goats. They have small means of defense, the horns of the males being only six or seven inches long, nor are they willing fighters; but the world they have conquered for their own would be sufficiently secure were it not for man, who in the role of the hunter, has proved a hundredfold more deadly an enemy to the Mountain Goat than is the panther. Man must play the Nimrod, must keep alive the passion inherited from a savage ancestry. Man must kill, and to prove that he *must*, will often risk his foolish limbs in situations that the hungry bear is wise enough to shun. The noble White Mountain Goat has suffered much as "game" for such hunters, and in many places has been exterminated.

The Ibex is another wild goat,—the largest of the family and it has so often been described that it need only be mentioned here, and the same is true of the great Markhor, a wild Himalayan goat with peculiar corkscrew-like horns that Mr. Hornaday says, "is the finest of all wild goats and in every way a picturesque creature. Their wonderful horns may be fifty or sixty inches long and make two complete turns before reaching full length." This goat is believed by many to be the parent, in part at least, of the valued Angora goat that is now so widely cultivated.

As stated in the beginning, the goat as a domesticated animal dates back to the dim gray dawn of civilization. It is closely related to the sheep, differing from it only in a few minor respects. Goats lack the hoof glands found in sheep and often have a rank odor. The hoofs of sheep and goats are cloven in like manner, the teeth are formed in the same way, but sheep have wool instead of straight hair, and the goat has in addition the beard in the male of the species. Tame goats, especially the old males are

prone to show ill temper and butt, a character that they have retained from their wild progenitors doubtlessly; but Mr. Fred Smith tells us that this is but empty bravado on the part of old Billy: "If his beard be seized he at once loses all courage, and begins to bleat in a very pitiful way." The goat is said to be a much more intelligent animal than the sheep and many interesting stories are told to prove this.

The native nursery of the goat may be said to be Asia. The wild goat of Persia which occurs from Crete to the desert hills of Cutch is the progenitor of most of our domesticated breeds. Today Europe could hardly do without the goat. This animal figures largely in the live stock of Italy, France, Spain, Germany, and Scandinavia. We can better understand this when we note that in little Corsica alone, as many as 90,000 goats are made to serve man.

The goat gives birth to two kids in April, and when young these little animals are pretty and truly interesting in their frisking play. The older animals are expert in getting a living from exceedingly scanty fare; they are browsers, and will eat bush, leaf, and ill tasting herbs with great complacency, and their climbing habits stand them in good stead, for they can reach a morsel of green herbage in this fashion that is physically beyond the mouths of most other browsing quadrupeds. It would be interesting to know how far back in the history of the goat the climbing habit was developed. Geologically, the goat has been traced back to the Pliocene: probably there he was as good a climber as he is today.

The goat is made use of in different countries according to the taste of the inhabitants. In some regions its flesh is much relished, especially the kids furnish good meat; the older goats become musky and inedible. Again, it is the milk that is valued and in Italy and Switzerland a cheese is made from goats' milk that natives of those countries are exceedingly fond of. It might be mentioned that the milk of this animal is peculiar to the taste and is not relished until one has acquired a liking for it. Skins of goats are used in many countries extensively for making morocco, gloves and many other articles. Mohair is also obtained from certain goats and this is valuable and much in demand. There are two famed breeds of Mohair goats: one, the Cashmere, which has long, straight, silky hair and has a winter under-coat

of very delicate wool which is used to make the famous Cashmere shawls; the other, the Angora, that has long, silky, curly hair which is used for all mohair fabrics. The Angora has been introduced into America and is now an animal of importance in California, Texas, Arizona and to some extent in the Middle West. In this country goats are sometimes used for pets only and happy is the small boy that owns a fine big buck with harness and equipage to match; he is happy indeed and proud, for the man who rides is proud, and what are our boys but little men. Many of us have seen the goat carriages on the Mall in Central Park, New York, and it has afforded a keen pleasure to many, I am sure, to sit on the pleasant benches under the noble elms that shade the Mall and there watch the tots making merry with the animal that has furnished the subject for this rather rambling talk.



### News Note

The President of the American Nature-Study Society, Professor Liberty Hyde Bailey with Mrs. Bailey and their daughter, Ethel, are sailing for China as this REVIEW goes to press. They expect to be gone several months, and visit Professor and Mrs. Sailor at St. John's College, Shanghai. Mrs. Sailor was formerly Miss Sara Bailey. They also expect to travel extensively in Japan. Professor Bailey and Miss Ethel hope to do some very interesting botanical collecting in both China and Japan. May good fortune attend their footsteps!



The Living Spring—below the tidal wave of winter.

## Fishing in Winter

MATHILDE SCHLEGEL

East Aurora, N. Y.

When fierce Brother North Wind comes rampaging around with his icy blasts straight from the Pole, all the little creatures of the meadows and forests either make sure of their hoards of nuts or seeds, or locate food supplies,—for this is the season of high cost of living for them, even they do not escape that; or perhaps they go fast asleep for the whole winter,—which is by far the easiest way out of the difficulty. We know who these sleepers are among the big folk; Buster Bear, Johnny Chuck, Bobby Coon, and a good part of the time, Whitefoot the Deer-mouse (but the finding of Whitefoot hibernating is another story).

To those who seek to have more than a superficial acquaintance with Nature, who look beneath the surface, we find it is not alone among these that Nature has her problems. As Jack Frost that page-sprite to Brother North Wind trips along and draws his fingers over everything,—the meadow grass, the trees and bids

them cease their work for rest time is approaching, he lightly fingers even the surface of the ponds and more quickly the tiny pools and all the forms of life within are affected and begin their long winter sleep we call hibernation.

Yet Nature is not wholly helpless, subject to the pranks of Jack Frost or even the will of the fierce North Wind. Always she can hold out a restraining hand and say "So far and now cease." Her ways of protecting dormant creatures are wonderful; she may give them storage of food-fat, or cradle them high in cold and damp proof casing, or snuggle them deep within the ground in their burrows snug and warm; but it is not often that she permits any of her children who ought to be fast asleep to live their lives in an almost normal manner though the temperature outside may hover close to zero. There is one way in which this is possible. From the base of a low hill she sends forth a tiny trickle of water, always running, from some inexhaustible reservoir deep within, beyond the possibility of reach by either of Winter's Aides; verily a Living Spring. How well has it been named, living water in the midst of icy fetters of hard frozen pastures or among the forest "trees at leisure." We always pause when we find one during a winter tramp on snowshoes or skis.

Where a living spring flows you may always find something of interest, but if it has been boxed and thus given a reservoir there are greater possibilities; and so, one day, passing The Spring we went over to investigate its depths. The temperature outside was less than twenty degrees, within the clear water of the pool we saw water plants were growing, gently waving in its slight agitation, the purifying *chara*; and along the edges of the overflow showed the tiny green leaves of watercress which kept beneath the surface, for did one venture above, it quickly was nipped into a blackened wraith of a leaf.

Looking more closely we saw moving on the bed of the pool large yellow and green salamanders out of whose way wriggled big bullfrog polywogs. Water-beetles and water-boatmen came to the surface for air as they would any time in summer and small species of their kind scurried about.

We must come again with a fish-net. Fishing in the winter was a unique and fascinating idea, beside here was an opportunity to replenish the stock for the aquarium. So another day, after the deep snow had come and settled down sufficiently, we went



The verification of the expedition

a-fishing. The snow lay deep over the fields, but equipped with snowshoes it always is possible to carry the camera, and this expedition must be illustrated, for verification if nothing more. In addition to this, carrying the net was a problem for, besides its bulkiness I really did not quite dare being seen with it, so few people understand that one can be quite sane on a scientific expedition of investigation. I compromised, taking along a tea strainer and a bamboo stick (originally this had been a broom handle). A wide mouthed bottle in my pocket was to be the container for the specimens,—if not victims for they might freeze on the way home.

Arrived at the pool, passing on the way over, "the tidal wave of winter," the snowdrifts, the fishing apparatus was made by the simple expedient of tying the strainer to the bamboo pole and then I discovered a good reason for the ring in the handle of the strainer for I had to slip the cord through this to fasten it firmly



enough. Later, when fishing, it proved quite adequate; the large net would have been awkward in the small dimensions of the pool, while the strainer scooped up everything there was about.



The Salamanders

Before this I set up the scoop-net in the snow beside the pool, left my snowshoes too because they always are picturesque, and made the study so you may see the character and setting of this—sketch.

The “fishing” proved even more interesting than expected, for, besides the species already noted, the “net” brought up many forms of pond-life, water-bears, larvæ and microscopic forms so interesting to examine, and finally a frog, a nice green frog. It kicked in protest and I returned it to the pool. Here in this tiny stretch of water measuring ten feet in diameter and about two feet in depth, all of these creatures were living their lives as merrily as in summer. They could prowl in the muddy depths, or seek shelter beneath the long fringes of meadow grass which had fallen over its banks when nipped by frost, or hide under the plants growing in the pool all unmindful that outside the temperature might be zero or less and, if removed they would be frozen instantly. Thus Nature has still her way with them.

Their transportation was a problem and knowing that, I worked rapidly to collect what specimens were necessary yet not to exhaust the supply (the pool being fairly well stocked). Upon the return the bottle was carried in the pocket of my coat while

all the way I held my big fur mitten over it. Even then there was ice in the bottle and the newts were quite dormant when put into cold water. They revived, however, and were soon so active that two of them (the best ones of course) escaped in the night to their death crawling about upon the dry floors. The beetles and boatmen and polywogs quickly learned to share the food of the goldfish so all goes merrily here also.

Species active December 29 and January 20: yellow salamanders, leopard frog, predacious diving beetles (*Dytiscids*), small water beetles (*Haliphids*), mosquito larvae (*Corethra*), water boatmen (*Corisids*), several species of snails, lower forms of microscopic life, and water plants including water cress.

### A Remarkable Achievement in Animal Illustration

*The National Geographic Magazine* for November 1916 is epoch making in the history of the mammals of America. This number contains 61 superb illustrations in color of the larger North American mammals by Louis Agassiz Fuertes; and accompanying each figure is a terse, comprehensive and especially well written account of the animal's habits by Mr. E. W. Nelson.

The public has learned to think of Mr. Fuertes as an illustrator of bird life, but these pictures show that he is equally as strong if not stronger as an illustrator of animals. When Mr. Fuertes was a boy in college his Professor of Entomology said: "One feels in looking at his pictures of the grasshopper that the insect is actually crawling and getting ready to jump." This same quality of aliveness is evident in each and every one of these pictures. The thrilling presentation of the Peary caribou attacked by Artic wolves, or that of the free striding prong-horned antelope, or that of the howling Arizona cayote all exemplify this quality to a remarkable degree. We have always had a great admiration for Mr. Fuertes' backgrounds. They are true to nature and at the same time artistic and exquisitely appropriate. His spirited picture of the Arctic foxes in their snowy surroundings is beautiful from every point of view. Mr. Fuertes' contribution to science is of the highest importance and we return thanks to the *Geographic Magazine* for enabling him to put on record and place before the public these beautiful and life-illuminating pictures.



"My ears are very, very tall"

## Animal Folk in the Meadow

A PLAY FOR PRIMARY GRADES

JANE M. BEILBY

Teacher of Nature-Study in Miss Faulkner's School Dedham, Mass.

### CHARACTERS

Indian Boy, Toad, Squirrel, several Sheep, and seven Rabbits.

### SETTING

A meadow with trees and several children representing sheep, who are pulling grass and wandering about, always following the one in the lead and frequently calling, "Ba-ah, Ba-ah." A little boy appears in Indian costume and sits on a stone.

INDIAN BOY.

"Of all the beasts he learned their language,  
Learned their names and all their secrets,  
How the beavers built their lodges,  
Where the squirrels hid their acorns,  
How the reindeer ran so swiftly,  
Why the rabbit was so timid,  
Talked with them when e'er he met them,  
Called them 'Hiawatha's Brothers'."

TOAD.

*(A toad hops in and meets squirrel near a tree.)*

"How do you do, Mr. Squirrel! What are you doing to-day?"

SQUIRREL.

"Oh, I am gathering acorns and storing them in various handy places near home for use this winter. Do you want to see my home? It is right in this tree. I am just about to take up a load and will show it to you." (*He climbs the tree, the toad leaps and hops after him to the base of the tree.*)

SQUIRREL.

"Come on Mr. Toad, what is the matter? Don't you want to see my home?"

TOAD.

"Oh no, I'm too busy catching flies and insects. I'm on my way to Hiawatha's garden to catch the insects there that injure his plants."

(*Seven rabbits appear from different places where they have been hiding in bushes and brush heaps.*)

TOAD.

"Oh, here come the bunnies." (*He turns to the sheep and says*)  
 "Come on comrades, the rabbits have come out to play. Let's all wait here and listen to what they have to say."

(*The sheep gather, the squirrel comes from the tree and they all listen while the rabbits recite. The rabbits skip about and play leapfrog between the verses.*)

FIRST RABBIT:

"I am little Molly Cottontail.  
 My fur is nice and gray,  
 And if to see me you should fail,  
 I was meant to be that way,  
 I look just like the hay."

SECOND RABBIT:

My ears are very, very tall,  
 When I listen for my foe,  
 And down along my back they fall,  
 When I am lying low,  
 But every sound I know."

THIRD RABBIT:

"My eyes are placed so I can see,  
 Behind and front as well,  
 My nice nose wabbles constantly,  
 My enemy to smell,  
 Before he comes pell mell."

FOURTH RABBIT:

"I have some bunny comrades gay,  
 By night we jump and run,  
 Leap frog and tag, we like to play,  
 And have whole loads of fun,  
 And fear not dog nor gun."

FIFTH RABBIT:

"Do you know we always have a guard,  
A sentinel to peer,  
Who thumps the ground so very hard,  
That all of us can hear,  
If an enemy comes near."

SIXTH RABBIT:

"We flee through briar and thorn,  
In run-ways none can follow,  
My home is in a cosy form  
Down in the grassy hollow,  
Where all the weeds run fallow."

MAMMA RABBIT:

"And there I make the nest  
For my bunnies blind and wee.  
I pluck the soft fur from my breast  
To cover them when it is best  
That I should elsewhere be.

*(When the rabbits stop reciting, the Sheep, Rabbits, Squirrel, Frog and Indian boy all join hands and recite together this verse from "Wind and Weather" by L. H. Bailey.)*

"Weather and wind and waning moon,  
Plain and hilltop under the sky,  
Ev'ning, morning and blazing noon,  
Brother of all the world am I."

## News Notes from Rhode Island

The Park Museum of Providence is another live wire in the nature-study circuit. Sunday afternoon lectures by specialists on many interesting scientific subjects were a part of the Museum program. On Saturday mornings at 10:30 Miss Eva W. Magoon, Assistant Curator, gives half hour talks to children. Her topics are interesting and pique curiosity, such as "Who's Who Among the Stars," "How Birds are Named," "Nature's Alphabet," "Nature's Hiding Places."

The Park Museum Bulletin for January lists the lectures given in the Museum and outside of it, field trips, loan material, Audubon library, and gives a very interesting graphic table showing the number of questions answered by the Museum during each month for the past four years. The increasing use of the museum in this department is most gratifying.

The Audubon Society of Rhode Island had a Christmas Bird Census meeting.

# THE NATURE-STUDY REVIEW

DEVOTED PRIMARILY TO ALL SCIENTIFIC STUDIES OF NATURE IN  
ELEMENTARY SCHOOLS

Published monthly, except June, July and August. Subscription price, including membership in the American Nature Study Society, \$1.00 per year (nine issues). Canadian postage, 10 cents extra; foreign postage, 25 cents extra.

**Important** Please note date of expiration of your subscription on the label of the wrapper. Subscriptions must be paid in advance to comply with postal requirements. Subscriptions and advertisements should be sent to *The Comstock Publishing Co., Ithaca, N. Y.* Manuscripts for Publication and Books to be Reviewed should be sent to the Editor.

---

## Editorial

Nature-study and natural history are terms that are confused in the minds of most people and especially in the minds of most teachers, yet the fields of the two are sharply defined in the terms themselves. A nature-study lesson is one in which the pupil consults Nature to ascertain the answer to his questions; but when he consults books to ascertain his facts, he is studying natural history.

As a matter of practical teaching the two work hand in hand in the school-room as in the laboratory. All that is possible to be discovered through observing an object is first accomplished and then books are consulted to round up the knowledge of the subject. The two are equally legitimate in a course of nature-study planned for the grades in the elementary and primary schools. However, great discretion is needed on the part of the teacher to know just how to use the two in order to make each stimulate a desire for the other.

A rule that should be closely adhered to with young pupils is not to permit them to read about an object until they have studied it and have become interested in it. There was a series of readers published about thirty years ago, devoted to descriptions of animals, birds and insects and their habits. The reaction against these stories on the part of the children was often most unfavorable. We once talked to a boy who said he hated ants, and on inquiring the reason for this attitude, we found his dislike came from having to read a story about these insects in one of these readers.

It is well to remember in this connection that the child is interested only in the story of action; and the more dramatic the action the better. The boy who hated ants, liked the stories of lions, panthers, and bears very much, because all these stories he had found not only interesting but thrilling. It is a matter of experience that after a child has observed a creature, he becomes interested in reading about what it does, even if there is no thrilling story connected with it. In a certain school reader which we recall, there is a page or two devoted to the habits of the lobster that did not seem especially attractive to anyone. But, one day the teacher brought to the schoolroom a live lobster which acted properly indignant at being handled, and an interest in the animal was suddenly developed and rose to a high pitch as its queer appendages and actions were observed. That afternoon, in the street car, we met a small acquaintance who was poring over the lobster story in his reader; his face was alight with enthusiasm as he explained what he was reading about and recounted his observations on this creature. If the little boy who hated ants had been able to watch all of the wonderful things that happen in an ant nest he would not have loathed the story in his reader.

There are many nature-study lessons during which only a small part of what there is to be known about an object can be observed. Take for example the screech owl which has been captured and brought to the schoolroom. The appearance and actions of the bird can be observed to the fullest extent; but the story of the bird's habits, its noiseless nocturnal hunts for mice, its loving loyalty to its mate, its intimate nesting ways, and many other things about it must be given to the pupils by the teacher orally or he must read about them in the bird books.

No good course in nature-study is independent of natural history; and a course in natural history would be arid and meaningless without nature-study. Happy is the teacher who understands how to supplement the one with the other and to make each a stimulus to further interest in the other.

## The Teacher's Corner

At the beginning of the year it was part of the plan of **THE REVIEW** that the present editor should write lessons for each month on timely topics, and since everyone who has **THE REVIEW** has access to the Handbook of Nature Study, these lessons were supplementary to the ones published in the volume. However, the situation has changed. It is scarcely becoming to an editor to fill pages of a periodical with his or her own writing. Therefore, hereafter there will simply be a list of topics for the grades given.

Owing to the new plan of making each number of **THE NATURE STUDY REVIEW** specialize in some particular subject, it has seemed to the editor that lessons outlined on the subjects discussed in each number of **THE REVIEW** by different writers would be a practical help. Thus in this number you have interesting stories of the skunk, the goat, and the white rat. The plan for using these in school work follows.

### THE SKUNK

In a nature-study lesson we needs must have some actual observation in order to stimulate a desire for further knowledge. I had in mind to suggest that just a smell of the skunk, if strong enough, is a quite sufficient basis for a nature study lesson, simply because through being able to emit this odor, the skunk has been influenced fundamentally in its habits. The odor has been such a powerful means of defense that this little creature is practically fearless and walks about where and when it wills, being certain that nothing will happen to it. To be sure this feeling of safety leads to tragedies with trolley cars and autos; but these are too late inventions to have become a part of the skunk's racial philosophy.

Thus the leading thought in giving this lesson should be a study of the effect upon the animal's habits by this means of protection. Almost every child in the country has had some experience with the skunk and should be asked to express his ideas and opinions upon the subject. Further than this the following points should be covered by observations, if possible. (1) The skunk does its hunting at night and its black fur protects it from being seen by its prey which consists largely of mice. On the contrary, its white stripes render it sufficiently conspicuous from above to the large animals that might attack it to render



it safe from molestation. Its fur is very valuable. Its bushy tail helps to keep it warm in winter and, as Mr. Knight shows, helps to defend it from the bumblebees. (2) The head is triangular and sharply pointed at the nose. The eyes are not very keen. (3) The front legs are much shorter than the hind legs and are armed with sharp claws for digging both for food and in making a burrow. Although it holds its food fast in its front paws it never uses them to lift the food to its mouth as does the squirrel. (4) Its food consists largely of grasshoppers, white grubs, mice, moles and insects. On the whole it is beneficial to the farmer. The only harm it does is to raid the hen-house occasionally and to destroy the nests of beneficial birds that build on the ground, and to destroy bumblebees that are of great importance to the clover crop, the pumpkin, the squash, and many valuable plants. (5) The skunk's home is in a burrow which it may make for itself or steal from a woodchuck. It also makes its nest in protected places sometimes under barns. The young are born in May in an enlarged portion of the burrow where a nice bed of grass has been placed by the mother for their comfort. (6) Skunks get fat in the fall and sleep during the winter.

#### THE GOAT

It is to be hoped that in the neighborhood some child has a pet goat that may be used for observation. The following points should be brought out. (1) Goats are among our most interesting domesticated animals and have played an important part in the history of mankind. (2) The goat is fitted to climb high and dangerous places; it is very agile and quite able to get its food on high mountains where vegetation is scarce. (3) The covering is of hair which is a great protection in the cold heights of mountains; the male has a beard or goatee. The hair of the Angora goat is used in making mohair goods. (4) The teeth consist of six molars on each side of the jaw. There are eight lower incisors below and none above. The teeth are especially fitted for browsing. (5) The goat's sense of smell is very acute and so is its sense of hearing. The eyes are full and intelligent. (6) The horns are somewhat flattened and knobby in front and curled backward; they are very efficient weapons of offense and defense. (7) The legs are strong and fitted for running and leaping. The hoof is cloven, that is, the goat walks on two toe nails. There are two

smaller toes above and behind each hoof. The tail is naturally short. (8) When angry, the goat shakes its head and stamps. (9) There are many breeds of goats and they are of use in the following ways: To produce milk which is very nutritious and from which a special cheese is made; the flesh is eaten; the hair is woven into fabrics; the skin is used to make gloves and morocco, and is also used for bags in which water is carried in the Orient; goats are used as pets.

#### THE WHITE RAT

This should be a study of the interesting ways of this pet as suggested in Professor Bailey's article. The observations should cover the following points and many more:

(1) The length of the tail compared with its body, the covering of the tail and its use when the rat is climbing. (2) The hind legs are long and strong fitted for jumping. Compare front feet with hind feet. Describe the claws and their uses. (3) Note the eyes, shape of ears, shape of snout, the whiskers and their use, the mouth and arrangement of teeth. (4) Actions of the rat when it is reaching up to examine something, how does it hold its front feet? (5) Describe how a rat washes its face—its back and its feet. (6) Note how a rat acts when eating. (7) Does it make any noises, if so what do they mean?

#### NATURE-STUDY TOPICS FOR MARCH

Second grade (1) A study of the buds of trees, including both leaf and flower buds, brought into the schoolroom and observed as they open. (2) The planting of seeds in pots and boxes or "egg-shell farms" and the study of their development, (3) A bird calendar for the first appearance of our most common and well known birds.

Third grade: (1) Migration stories of our most common birds. (2) Begin a detailed "line a day" story of the robins and of their activities from the time of their first appearance. (3) The rabbit; a study of the domesticated varieties should lead to a study of the wild hare "the cottontail". (4) A study of the pussy willow including as well the pistillate catkins that produce the seeds.

Fourth grade: (1) The meadowlark; personal observations should be supplemented by reading. (2) The muskrat; this may be personal observation and natural history. (3) Skunks cabbage; compare with jack-in-the-pulpit and calla lily. (4) Seed testing.

## The Book Shelf

*The Way Life Begins*, by Bertha C. Cady and Vernon M. Cady.  
American Social Hygiene Association, 105 W. 48th Street,  
New York City. \$1.00

This very interesting and beautifully illustrated volume is a scientific and logical introduction to sex education. It is for parents and teachers essentially, although, if it should fall into the hands of a child, it could do nothing but good. However, the material is arranged so as to be given in a series of lessons which in the case of plants should be illustrated by observation. The first chapter is a sermon that should be taken to heart on the deeper meaning of nature-study. The first lesson is a charming one on the pollination of the lily including the carrying of the pollen from flower to flower by moths. This study forms a basic lesson in reproduction. The next lesson is the life story of the Cecropia moth. There follows this the story of the fertilization of the eggs of fish through the agency of the milt,—as impersonal a story as that of the pollination of the lily. The next natural step involves a more personal relation of the parents, as illustrated in the life histories of the frog and toad. Then comes the mysterious inner history of the egg traced from its beginning to the hatching of the chick. This leads up to a study of the rabbit which gives a complete history of the fertilization of the ovum of the mammal, stress being placed upon the fact that the reproductive organs of the male and female are essentially alike in origin and thus shows that the development of sex is nature's way of dividing the labor of reproduction. After these lessons the step to the origin and growth of the human embryo is but a short one and this chapter is written with detailed and straightforward information.

Mrs. Cady was formerly a very successful nature-study teacher in the Oakland, Cal., schools and was thus peculiarly fitted for her part in this important volume. The last chapter deals with nature-study and the personal problems of life and should be read by every one. She makes it very plain that when the child is young and without sex consciousness is the time when it should become familiar naturally with the methods of reproduction in plants and lower animals. A child thus trained is ready for the revelation of its own origin and as Mrs. Cady well says when we are thus trained "we shall no longer think of sex reproduc-

tion as debased or alien to our humanity." The book is ideal in its straight-forward simple method of approaching this most important subject and it forms a worthy guide to be used in setting the feet of youth in the path of chastity and righteous living.

*Judging Farm Animals* by Charles S. Plumb, Professor of Animal Husbandry in Ohio College of Agriculture, Orange Judd Co., \$2.25.

Any book written by Professor Plumb is sure to be interesting and this volume is no exception. It begins with a clear and incisive discussion of form and function which gives the basis for judging animals. The Score Card and its use are fully explained; then follows chapters on judging horses, cattle—sheep, and swine. Each chapter contains a study of the internal anatomy of the animal and of the different types which have been developed; what makes this book of special practical value is that a Scale of Points is given for each breed of farm animal. At the end of the book there are given the rules governing live stock judging contests and the rules of students' contests in judging dairy cattle at the National Dairy Show of 1916. It is a well written, clear and comprehensive book fitted equally well for the farm library and also for a text in agricultural colleges.

## General Science Quarterly

Devoted to Science in the Elementary and Junior High Schools

"I do not think that any amount of pains and ability in the high school can make up for a wrong start or even a failure to get the right start (in science) in the grades". *John Dewey.*

Some articles of interest to elementary school teachers are:

Connecticut System of Elementary School Science.	<i>Higgins</i>
General Science in the Rochester Junior High School.	<i>Carpenter</i>
Why Science in the Grades . . . . .	<i>Rowell</i>
An Experiment in Eighth Grade Science . . . . .	<i>Patton</i>
Method in Science Teaching . . . . .	<i>Dewey</i>
Project Teaching . . . . .	<i>Kilpatrick</i>
Twilight . . . . .	<i>Whitman</i>

Ask to have this journal in your school library and subscribe yourself. It will give you many practical helps.

Send 25c for a sample copy or \$1.25 for a year's subscription. If you wish back numbers of vol. I, please so state in your letter.

**W. G. Whitman, Managing Editor, State Normal School**

SALEM

MASS.

# THE NATURE-STUDY REVIEW

VOL. 13

APRIL, 1917

No. 4

## Royalty in the Plant Kingdom

or

### A Glimpse of Court Life at the Court of the Royal Lady-Slipper (*Cypripedium reginae* Walt.)

E. EUGENE BARKER

Assistant Professor of Plant Breeding, Cornell University

“Rushes tilting their burnished spears,  
These are her courtly cavaliers,  
Heart of my heart, we forswear the rose,  
We have been where the lady-slipper grows.”

With these words the poet acknowledges the stately graces of a wild flower that outvies the charms of that queen of flowers, the rose itself. Any person, who has been privileged to see this flower growing in its native habitat, rising regal and stately from softest cushions of exquisite mosses and bearing full flowers of purple and white, must be constrained to agree with him.

Not a little of this plant's charm is due to the glamour of its surroundings and to its habits. Exclusive to a degree, it prefers the retreat of some cedar swamp or sphagnum bog, where its thick, fibrous roots penetrate the cool substratum of muck, and its broad, ribbed leaves expand in the hot humid air that swathes such places during the intense days of summer. About the last week of June, usually, the stout hairy stem with its great column of leaves attains full height and discloses flower-buds at the top—one, often two, occasionally three, round as nuts and creamy white. They are nodding and modest at first; later, as they grow in size, they are lifted, and one fine day the sepals are unfurled as gleaming white banners, and the great inflated pouches flushed with royal purple are borne proudly erect at the top of the stem.

One feels, as he stumbles upon a group of these magnificent plants, in some wilderness, that he has blundered into an enchanted precinct, where they are holding court in a different world

of their own. He feels himself an intruder, and moves about with deference amongst them. He notices the bees coming and going from flower to flower and, if he is a sentimentalist, he will regard them as courtiers; if he has a smattering of biological knowledge, he will say they are servants carrying the golden pollen masses so that the needs of reproduction may be fulfilled; if he is a gross materialist, he will perceive that the bees are visiting the flowers for the sake of gathering pollen and possibly nectar intent solely on satisfying their own selfish needs, and that the flowers in turn are passively securing the services of the bees to effect what they cannot do unaided—insure a set of seeds. For this purpose the flaunting expanded sepals of gleaming white, the labellum suffused with color; for this purpose its marvelous shape, that forces the insect visitor to crawl thru it and out underneath the sticky stigma, leaving upon its surface the vital fecundating pollen substance, and then to scrape onto her thorax again, more pollen from this flower's anthers, to be carried to the next flower she visits and thus bring about cross-fertilization. Cold, utilitarian facts in the economy of nature, but showing such marvelous perfection of mechanical structures for definite functions, such correlation between the needs of plant and insect and withal such beauty of color and form appealing to man's esthetic sensibilities that there is forced upon the observer an admiration for the ways of nature's working and the beauty of her perfected forms. One can search far, in the kingdom of nature, before discovering more perfect illustrations of adaptation of structure to function or of dependence of one organism upon another than he will find here exemplified in this member of that wonderful group—the orchid family.

The flower is so constructed that no seed could ever be produced without the service of some agent to transfer the pollen from anther to stigma; it is utterly incapable of effecting self-fertilization. The question arises, then: What insects are sponsors for this plant's continued existence, and what species are these colors and shapes and this rich, heavy odor especially suitable to attract? Natural philosophers of a different age might have speculated and theorized ingeniously, but we of to-day seek answer to such questions in the simple and commonsense way of going and watching the plants where they are growing.

The writer once had the opportunity of making some interesting observations that threw light on this question of the interdepen-

dence of flower and insect in this case. Provided with a butterfly net and a lunch he entered a bog where the lady-slippers were in full bloom—he also carried a bottle of citronella—(you see, this was not an enchanted fairyland, else there would have been no mosquitoes). Presently he found himself in the midst of a royal company of orbéd blossoms; they surrounded him on all sides; by turning around he could count 200 within sight, and there were countless others beyond. They rarely grew singly but usually in clumps of several to as many as 20 or even more from a single root. Here was an ideal place to seek an answer to the question. Would it be answered here and now? What insects might he see in the very act of pollinating the flowers? Everywhere about him were the remains of last year's crop—old stems, almost all of which still bore empty seed pods, which mutely attested the fact that each flower had been pollinated.

The observer settled himself as comfortably as possible amidst the hummocks of wet moss, and the stunted cedars, and waited. The minutes lengthened into hours, the hours passed, but not unpleasantly in such a place amidst such company. Occasionally a gay butterfly fluttered past, perhaps hesitated and approached a flower, attracted by its color and faint oily perfume. Perhaps he even alighted for a moment on the labellum of the flower. And then the excitement of the observer waxed intense and the collecting net was grasped tightly in readiness for action. But quickly the butterfly always passed on—for why should he remain when the flower set forth no available nectar, and even if it had done so, of what use would have been his long, slender proboscis? The shape of the flower was obviously not adapted to him. Once a pert little green grasshopper accidentally landed on the lip of the flower, but he too went on his way as he had come. But sometimes a bee, flying swift and straight, came in a business-like manner, alighted upon the labellum, proceeded immediately to enter it thru the large aperture at the top and then crawled to the only exit up under the column of the flower. This led her directly underneath the stigma. There was just room for her body to pass out on either side right underneath an anther, where she could not avoid having her thorax smeared with the sticky pollen mass. The flower was perfectly adapted to an insect of this size and shape and the bee's acts and manner were tacit recognition of this fact. Furthermore, such plants, as grew in the shade of the cedars and

were somewhat sequestered from the flight of the sun-loving bees, set fewer seed-capsules than those which grew in the open. The proportion was about one-half for the latter and only a little over one-fifth for the flowers that grew amidst the trees. The specimens

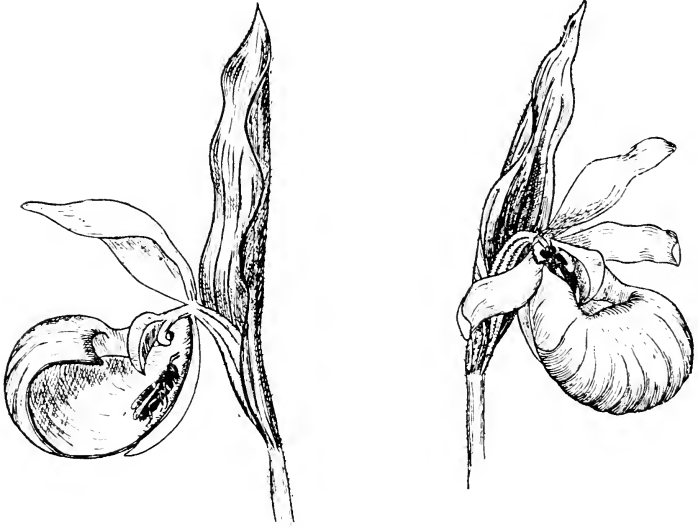

At the left a moccasin flower in section showing the bee on her way out of the sac with the stigma and anther above her. At the right the bee is shown crawling out of the small opening and becoming smeared with pollen from the anther that brushes along her back.

of bees captured by the observer in the act of visiting these lady-slippers all belonged to the genus *Andrena*.

Such, then, is a glimpse of the intimate life of royalty in the plant kingdom, as seen by one who has been privileged to spend some time at court and observe and record these incidents himself.



## The Royal Moccasin Flower

EDNA LOUISE BARKER

When June, the magic month, comes 'round  
With all her fairy train,  
I long to quit the city streets  
And roam the hills again.  
I long to hear the wild birds sing  
In far, secluded bowers,  
And back among the green-girt hills,  
To seek the Moccas'n Flowers.

The noisy pavements, grey with dust,  
May hold my lagging feet—  
My spirit wanders, as of old,  
Thro' young grass, lush and sweet.  
Beyond the walls that hem me in  
Thro' all the golden hours  
I know the mountain breezes blow  
Across the Moccas'n Flowers.

Swayed on their slender velvet stems,  
All leaved in emerald dresses,  
In whispered conversation each  
Her loveliness confesses.  
Like silver-frosted moon-moths poised  
Above their painted shells  
Their frail twin petals draw the light  
Down to their scented wells.

For them the pollen gathering-bee  
Serves well for hidden pay.  
Round them the gorgeous butterflies  
Their rain-bow wings display;  
The cricket tunes his eerie viol,  
The thrush pours forth her song;  
Green fern and brake and slender rush  
Bend to the stately throng.

Oh, soft and cool the breezes blow  
By those deep-hidden nooks.  
And sweet the ceaseless melodies  
Of sun-ensnaring brooks.  
When June, the magic month, returns  
To her enchanted bower  
And brings the queen of loveliness—  
The Royal Moccas'n Flower.



## The Skunk Cabbage, a Swamp Hostelry

E. LAURENCE PALMER

Professor in Science in Iowa State Teacher's College

It is fortunate that the likes and dislikes of all living things are not the same. It is also remarkable that some of the most disliked, ugly and disagreeable and unpretentious objects about us may be the most interesting. Many of us have had the experience of walking through a bunch of skunk cabbage in the spring. Few of us, probably, cherished the experience as a pleasant one and yet these seemingly disagreeable plants of the marsh are very interesting, indeed.

A glance at one of the first shoots sent up by this announcer of spring cannot help but give one the impression that here in the

woods is a little house of some sort. The overhanging roof, the open door, all of these things remind one of the entrance to some of our hotels. The comparison is not far wrong for here, in fact, is the retreat or temporary home of some of the inhabitants of the region round about.

Most of us would not cherish a visit to a hotel possessing the aroma which fills the air about these plants but then, we are not the welcome guests. As in Postum, "There's a reason" so here there's a reason for all of these "airs." Very probably, the odor serves the purpose of advertising to certain passing insects the fact that here is a place where board and room may be had for the asking. In these days of the reign of the H. C. of L. such an hotel would undoubtedly prove very popular to most of us.

If we look under the portico of this wet-woodland hostelry, we will see within a large room with a structure which looks not unlike a ball in the center. Possibly the visiting insects interpret the ball differently than we for at any rate they proceed to enjoy themselves in this "ball-room." If we look into two or three different hoods we will find that the balls are not all alike. Some, we will find covered with groups of stamens, four in each group. Others show only the tip ends of the pistils. If we visit these same plants later on, we may find the order reversed or we may find still other plants in which the stamens and pistils appear at the same time. In this latter case, the stamens will probably be found at the top and the pistils showing below. There seems to be no fixed program for the appearance of these different parts as either the stamens or pistils may appear first.

It has been suggested that the insects which attend the parties given in this "ball-room" may be carrion flies. Their visit results in "carryin'" pollen, however, and it is probably because of this trait that so much attention is paid them by the plant to make them welcome. At any rate, the insects which enter the door, find a large, airy (?) room where wind and rain cannot bother. To be sure, the roof serves the double function of protecting the pollen and protecting the insect guests. For that matter, all hotels not only serve to give a temporary home for travelers but also serve the purpose of caring for the owner of the building. What is more the woodland hotel is a decided improvement upon the man-made imitation for here we find not only food and shelter for the guests but the wherewithal to pay for that food and shelter. In the

invention of man, the guests depart minus more or less wealth. In the "Skunk Cabbage Hotel, Ltd.," we find the parting guest dusted all over with pollen which may be used to pay for room and board at the next hotel visited. Anyone who has spent time and other things in a modern city hotel can readily appreciate the advantages of this obscure and out of the way swamp hostelry.

In spite of all of these inducements to patrons, there is always the possibility that the desired guests will not arrive and when one looks at a patch of skunk cabbage he can easily realize that there may be considerable competition. Fortunately for the skunk cabbage, everything is not absolutely dependent upon insect visitors. If no guests arrive, those plants in which the stamens show first can still keep on a running basis for we find that the pollen from some flowers in the head will fall on the pistil tips of other flowers in the same head. In that way we see that there is little danger of failure in gaining the desired result.

After the pollen has been deposited on the pistil either by a visiting insect guest or by dusting from neighboring flowers in the same head, we find that guests are no longer welcome. The hotel begins to close its doors. Undoubtedly any man-made hotel would of necessity close its doors too if it were to run on the same plan. At any rate, the hood bends down and the regular well-known leaves appear. All summer long these leaves work laying up food both underground and in the treasure vaults where the pollen has been deposited. If we should look for the remains of the spring flower we will find that it has transformed into a sort of berry sunken in the fleshy part which made up the ball for the most part. These seeds often enter into the menu of some wandering muskrat or better still grow into a new skunk cabbage plant.

The whole plant seems to live an unattractive life. There are no brightly colored flowers for us to pick and the odor certainly doesn't make a favorable impression upon our noses. But then, the skunk cabbage doesn't grow for our particular benefit. If it weren't for the odor we probably should never notice the plant at all. Muskrats, insects and creatures of that sort can find plenty of interest in the homely plant. There is interest and to spare for us there too if we only go after it. Any effort devoted to finding out some of the secrets which it holds will be well repaid and our concept of the skunk cabbage will be much more pleasant than the first impression we get by means of our noses.

A very similar lesson or story may be made using the Jack-in-the-pulpit in place of the skunk cabbage. "Jack" makes just as good an inn-keeper for the purpose of a story as he does a minister. The odor of "Jack's Hotel" is only slightly less fragrant than that of the "Skunk Cabbage Hotel, Ltd." and the guests are quite similar.

---

## The American Attitude Toward Flowers

L. H. BAILEY

America is the land of cut flowers. Nowhere else does the cut-flower trade assume such commanding importance. Churches and homes are decorated with them. One sees the churches of the Old World decorated with plants in tubs or pots. The Englishman or German loves to care for a plant from the time it sprouts until it dies; it is a companion. The American snips off its head and puts it in his buttonhole; it is an ornament. I have sometimes wondered whether the average flower buyer knows that flowers grow on plants. Flowers are fleeting.

All of us have known people who derive more satisfaction from a poor plant that never blooms than others do from a bunch of American Beauty Roses at \$5. There is individuality—I had almost said personality—in a growing, living plant, but there is little of it in a detached flower. And it does not matter so much if a plant is poor and weakly and scrawny. Do we not love poor and crippled and crooked people? A plant in the room on washday is worth more than a bunch of flowers on Sunday.

Extract from *The Nature-Study Idea*.

---

## Good News

The good news has reached us that Professor L. H. Bailey and family have had a successful voyage as far as Honolulu where they spent twenty-four hours, which time was mostly spent in a celebration of their advent by the overjoyed Cornellians who have found homes and work on those delectable islands. The Baileys plan a more extended visit in the Hawaiian Islands on their return; they are now arriving in Japan.

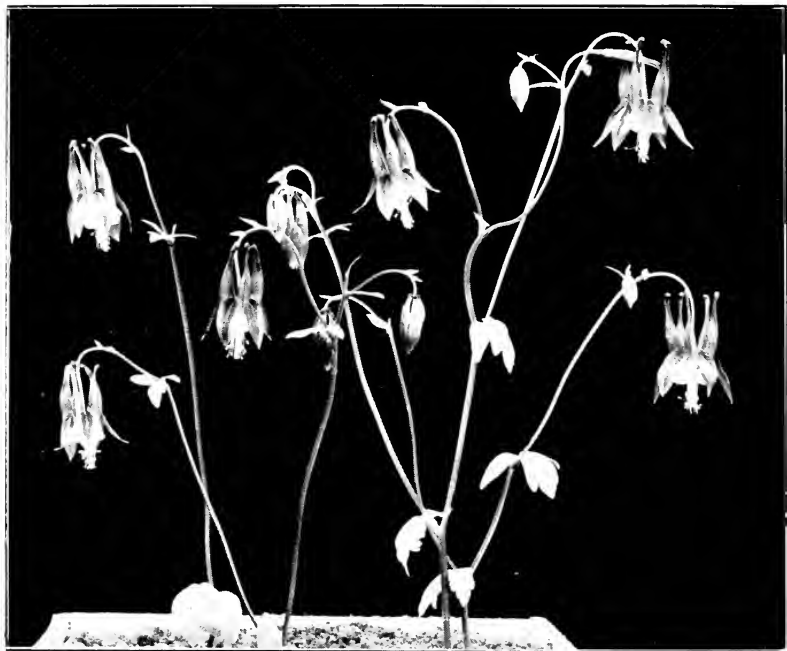

## The Columbine

JAY R. TRAVER

Willoughby, O.

"Columbine is dancing,  
Lithesome, blithesome maid,  
Where the sun is glancing  
Thru the woods' new shade.  
On her rocky ledges,  
Tilting on their edges,  
In a pose entrancing  
Gayly unafraid."

Spring comes, April, May and June, bringing a riot of beauties and exposing miracles ever new, of unfolding leaf and flower. "Then it is that the columbine begins its reign of fire among the granite rocks of old hillside pastures," and high up on the inaccessible gray cliffs of gorges and ravines. It is well for this fairy flower that it is enabled to find a foothold where man cannot climb, for such an entrancing bit of flame, dancing with every passing breeze, would fall an easy prey to many, who with thoughtless hand might

snatch it up by the roots and bear it away, too often to cast it by the roadside before even reaching their destination, when their passing whims had fled. For there is no flower, however beautiful, in its native haunts, that does not lose its charm when taken away: as Emerson wrote of the sparrow,

“For I did not bring home the river and sky,  
He sang to my ear,—they sang to my eye.”

But no cliff is too sheer, no rock too steep, to keep away the visitors whom the columbine invites, with its flaunting yellow and red tasselled bonnet nodding a welcome as they approach. Hither come bees great and small, hawkmoths and humming birds on swift wings and for them a feast is spread.

“So in her red gown, trim and fine,  
Merrily dances the columbine.”

Columbine or *Aquilegia* belongs to the crowfoot family. From England our Pilgrim fathers brought the hardy perennial columbine (*Aquilegia vulgaris*), a native of Europe and Asia, not knowing that in their new home they would find the even more beautiful, wild perennial, the red columbine (*A. canadensis*), the common form native to New England and the Middle States, often erroneously called wild honeysuckle. In the western states two other forms, the western columbine (*A. formosa*) and the Colorado columbine (*A. caerulea*), are found, the latter having been voted the state flower of Colorado.

The five peaks of columbine's bonnet are formed from the five petals, each a veritable horn of plenty, the tip end filled with nectar. As the flowers bow their heads, this nectar probably flows slowly down into the lower part of the horns, allowing bees and other short-tongued insects to have a taste. The greedy bee, while clinging to the tassel of stamens and pistils, becomes dusted on the under side of her body with the ripe pollen, some grains of which she is almost sure to leave on the stigmas of the next flower she visits. But the “burly, dozing bumble bees” are less polite, and often bite thru the tip end of the horn, thus getting the nectar without repaying the flower by transporting some of its pollen. If no insects should come, it is probable that cross-fertilization would take place. But there is small chance of such an event, as long-tongued visitors, the butterflies, hawk-moths and humming-birds,

are not slow in accepting the proffered sweets, carrying away on their throats the precious golden pollen grains.

The sepals, five in number, are placed, one between each two petals, and are of the same color as the petals, in the wild columbine scarlet bordered with yellow. The stamens and pistils hang in a tassel below the flower, five pistils and many stamens. The anthers, before ripening, are arranged "in an inverted pyramid," each curled up at the tip, making them look "fat, yellow and globular," but when the pollen is ripe, the anther uncurls, extending down below its unripe comrades; but always the stigmas are lower still.

The plant grows from one to two feet in height, the leaves being olive-green in color, some growing from the root and others being placed alternately along the flower stem. The lower leaves are three-lobed, and the lobes are lobed, but the upper leaves are simply bracts at the bases of the flower pedicels. The seed capsule consists of five pockets, each opening near the tip when the seeds are ripe.

The name columbine is derived from the Latin *columba*, meaning a dove. Some think this name is appropriate because the claws of the blossom seem to associate it with the bird. Mr. Prior sees "the resemblance of the nectaries to heads of pigeons in a ring around a dish, a favorite device of ancient artists." Jean Ingelow writes:



The dove.

"Columbine, open your folded wrapper,  
Where the two twin turtle-doves dwell."

while others says it is derived from the fact that one petal and two sepals of the white columbine are said to look like a dove. Perhaps no one has interpreted this flower so perfectly as has Professor L. H. Bailey in his poems, "Wind and Weather," of which a part is given:

"Columbine  
What doest thou here  
Upon this chine  
Of rock-cliff sheer?  
\* \* \*

A quickened thing drawn from a stone  
With stems and buds and seed-pods grown



Seemly flowers with filaments therein  
 And pearling tubes with nectar in  
 Leaflets modelled tenderly  
 Rainbow hues  
 Winds and dews  
 And the spring's transparency  
 All in sweetest unity.

\* \* \*

Ah, the wonder that has run  
 That some sweet alchemy has won—  
 Kissed together stone and sun!

O Columbine,  
 The world is thine!

---

### January Wild Flowers

The California spring is far in advance of ours as the following note written in the middle of January by Miss Alice Eastwood, Botanist, of the California Academy of Sciences attests: "I was up to my place (on Mt. Tamalpais) yesterday and found a blue Iris in bloom, a wild one that hugs the ground and keeps its seed pod below the surface of the ground; it is called *Iris macrosiphon*, for the entire stem is the calyx tube. There were also in blossom *Zygadenus pedicularis* and a pretty Umbellifera called "*belaea*." The *Manzanitas* and *Ceanothus* are in bloom higher up, and have been in bloom for weeks.

I keep up an exhibition of the native and exotic flowers in bloom in the vestibule of the Academy of Sciences building (in Golden Gate Park). I have a stand with three shelves, each one smaller than the one below. I put a label on each kind of flower containing its scientific and its common name and the name of the country where it is native. Some day, I hope to have in one place in the park a representative collection of the plants in the park, arranged according to the system of classification and all labelled correctly. The park is so large that to find all the kinds of plants would be a task of years. There is probably no place in California where so many different species are to be found as in Golden Gate Park."

## \*A Schedule for Arbor Day Compositions on Conversation

Mrs. N. L. BRITTON  
New York Botanical Gardens

EDITOR'S NOTE.—Mrs. Britton has kindly prepared a schedule for Arbor Day compositions for THE NATURE-STUDY REVIEW. The topics are three in number; the points mentioned under A or B or C should be covered by the essay on that topic but not merely answered as if they constituted an examination paper. The best essay on each topic will be printed in THE REVIEW and should not contain more than one thousand words.

### A. OUR NATIVE TREES

1. How many and where are our National Parks? Name them.
2. What trees are most abundant in various parts of the United States? Which grow the tallest? Which live the longest?
3. Are there still any large areas in natural forest? Where?
4. Why is it important to preserve forest areas? How do they control our water supply and the flow of our streams and rivers?
5. Give the present prices of lumber and state the various uses to man.
6. What countries of the Old World have been largely deforested?
7. Which European countries have seen the necessity for reforestation?
8. What states have learned by experience to protect and increase their forest areas?
9. Have you ever camped in the woods? What rules should you observe in camping?
10. Are you a boy-scout or a camp-fire girl?
11. What cities are noted for their street trees? Which trees are usually most planted? Which are the best?

Ans. *The Red Oak*. (The *Ailanthus*, *Oriental Plane* and *Norway Maple* are of the best, but are not native.) *Native Maples* and *Poplars* are brittle and short-lived.

---

\*The schedule given above has been modified to suit the needs of teachers in other cities, from one which has been used for Arbor Day compositions in 1915-1916 in the public schools of Greater New York. The best compositions were selected and printed in the *Journal of the New York Botanical Garden* and reprinted for free distribution. Copies may be had on application to Mrs. N. L. Britton.

12. How are street trees injured? How can they be protected from injury?

13. Have you ever planted a tree? Is there any special preparation necessary? What does it cost?

14. Why was Arbor Day founded? Is it generally observed?

#### B. OUR SHOWIEST SHRUBS AND TREES

1. What native trees or shrubs have showy flowers or fruits?

Ans. Azaleas, laurel, rhododendrons; dogwood, magnolias, holly, winterberry, etc.

2. What is the color and size of the flowers or fruit?

3. Name the places where you have seen them growing wild.

4. Which are becoming rare or extinct? (Laurel and holly).

5. How are they destroyed?

6. Is there any way of preventing this?

7. Are there any of them in cultivation?

8. Is there any special preparation or protection necessary?

Ans. Most of these prefer leaf-mold to manure, and need mulching, some both in winter and in summer. (Rhododendron and laurel).

9. Have you ever planted a shrub? What?

10. Which ones are your favorites?

11. Are they native or introduced? What are their native countries?

12. Which ones are most attractive for their color?

13. Which ones are most attractive for their odor?

14. Are any of them used for perfumery?

15. What countries are famous for cologne and soap?

16. How are the perfumes extracted?

#### C. OUR NATIVE WILD FLOWERS

It is well known that in many places where wild flowers used to be abundant they are rapidly becoming rare or extinct. In the case of annuals, this is due to the fact that so many are picked that an insufficient number remain to form seed. In other cases, it is due to the clearing and burning of the woods, the draining of swamps, or the cultivation of the fields. Roadsides also are robbed of all their natural charm by insensate clearing and the automobile makes it possible to go further afield in search of woodland treasures! The spring flowers are most in need of protection

and should be picked in moderation without disturbing the roots: *Arbutus*, *hepatica*, *Jack-in-the-pulpit*, *spring beauty*, *wild pink*, *wild columbine*, *bird-foot violet*, *wild orchids*, particularly the *moccasin* flowers, pink and yellow, and *fringed orchis*; the *laurel*, *dogwood*, *rhododendron* and *magnolia*; also the *wild field* and *water-lilies*, and the *American lotus*, the *cardinal flower* and *fringed gentian* and *holly*. The ferns also should not be forgotten, *maiden-hair*, *climbing*, and *Hart's-tongue ferns*, etc. All these need protection, and the owners of places where they grow should try to save them! Many wild flowers can be grown and improve under cultivation, if proper soil and shade are given them and they are mulched with leaves.

Many associations are endeavoring to protect them and literature and information may be had from the following:

Wild Flower Preservation Society—New York Botanical Garden.

Chicago Chapter—Field Museum, Chicago, Illinois.

Pennsylvania State Chapter—State College, Pennsylvania.

Philadelphia Chapter—University of Pennsylvania, Philadelphia.

Society for the Protection of Native Plants—Horticultural Society, Boston.

Federation of Women's Clubs—Local State Chairmen.

Garden Club of America—Miss Marble, Bedford, Westchester County, New York.

## To Louis Agassiz Fuertes

WILLIAM P. ALEXANDER

Written on a fly leaf of "*Birds of New York*"

A master mind, an all-observing eye,  
 Combined to make his art most consummate;  
 With pigments blending tints of earth and sky  
 In pictured forms, that life doth simulate  
 In full perfection; he an art doth ply  
 That Nature's self can straight impersonate:—  
 His feathered folk might from the canvas fly  
 Instinct with song and wholly animate.

The sylvan idyl of melodious May  
 Is caught; and here the fierce, grim tragedies  
 Enacted oft amid the woodland trees  
 Is seen—the pinioned hunter and his prey.  
 Hail to the craft and skill that can ensnare  
 Our birds, yet leave them free in wood and air!



The group of adder's tongues.

## How the Plants Wake Up from Winter Sleep

FREDERICK V. COVILLE

Bureau of Plant Industry, U. S. Department of Agriculture

Once upon a time there were two little boys who lived upon a farm that was their very own. It was a stony, hilly, half-wild, woodsy farm, with a brook and a spring; and a bog where the sparkling sundew set its baited trap. The farm ran down on one side to a lake where the boys built castles in the sand, or frightened the darting pickerel through the lily pads, or played water tag with schools of curious minnows. There was a dark pine woods where the brook went over mossy stones and the trout lay watching in the pools, and farther down a thicket of alders where the woodcock hunted over the soft wet ground and left the mud full of holes, as he prodded with his long bill for worms. There were great red oaks, where the grey squirrels grew fat in autumn, and dark hemlocks in which the red squirrels chattered and scolded. There were berries to be picked, wild strawberries, and blueberries,

and red fragrant raspberries, and great sour thimbleberries, and blackberries, and dewberries. There were shady places among the sugar maples where one could hide completely in the ferns, and where the red newts came out of the dead leaves after a rain.

All the places were calling to the boys, and all the animals, to come and play, to come and hear their tales. They went often and they learned much, many and many a charming story. But the flowers were silent. The little boys used to pick them and carry them home, or make them dance in fairy circles on the sandy shore, or stand guard like steadfast soldiers along the brook. But the flowers told no tales. The little boys wondered and then they asked, but the flowers still were silent. One warm day in spring, however, as the smaller of the two boys sat on the brook bank putting on his sandals and looking at the sod dam he had just built, he heard a voice at his side, and being used to such things it did not startle him. "We flowers," it said, "are mostly a silent people. We do not come and go like the animals, or sing like the birds, nor do we crawl and eat like the caterpillars. We stay where we were born, and we are silent, but we are a very ancient people and we have learned many things, what we must do and what we must not do. We have taught the bee and the butterfly to work for us and we pay them for their labor. The wind works for us too, but him we do not pay. We are wise in the wisdom of our kind. If you will come again, I will tell you a tale."

The next days were cold and windy and cloudy, and the boys played in the snug old barn, burrowing in the haymows, building toy boats on the barn floor, and cracking butternuts on the solid oak sills. On the fourth day the wind turned northwest and the sun came out. It was warm in the southerly nooks and cold in the windy shade.

The tiny sailboat, after many crossings, had drifted unheeded to the sod dam, and the smaller boy was squatting before a group of adder's tongues, asking them questions. "Weren't you cold?" he said.

"Not at all," replied the one with the sunniest smile. "We never feel cold."

"Well you must have felt awfully cold last winter, any way."

"No indeed," she laughed. "We like it that way. And if you won't pull us up, I'll tell you all about it."

And then she told the story of the cold. During the long sum-

mer and autumn the plants are laying up a store of food for coming winter and spring. Day by day they add to the store, mineral food brought up from the soil through the roots, and starch manu-

factured in the leaves. The plant's active growth of spring and early summer has lessened or ceased, and in full leaf and full vigor for acquiring food, but with little or no present

use for it, the plant stores its daily surplus in whatever place

is most convenient: the adder's tongue, in the bulbs; spring beauty, in the tubers; anemonella, in the thick roots; the trees and shrubs, in the sapwood, the roots, the twigs, and sometimes even in the pith, when that stays alive from year to year.

The annual plants lay up nothing and when the frosts of autumn come they die, with the grasshopper and the stiffening katydid. But the other plants shed their leaves and begin their winter's sleep gorged, and surfeited, and fat with food. In the evergreens even the nooks and crannies of the leaves are used for storage.



The adder's tongue, showing its underground storehouse.

Drawn by F. Dana Gibson, a pupil in seventh grade.

"In the fall," said the adder's tongue, "we are so sleepy. Even the mellow Indian summer doesn't make us wide awake. And it's well for us that it doesn't. If we started growing in those tempting days we should use up our winter's supply of food, and freeze to death later. The warm-country plants that came north and were foolish enough to start growing in Indian summer were all killed

off thousands of years ago, and they didn't leave any descendants with that bad habit. No, indeed. We wait for the cold.

"The cold! Oh, how good it feels. It is so comfy. In Indian summer one feels all stuffed up, sort of bilious. Too much carbohydrates, the doctor would say. But when settled cold weather comes everything is all right again. Some of us don't really freeze at all. We are under a warm cover of leaves and a thick blanket of snow, and often even in zero weather, as the wise old wood-chopper can tell you, the ground about us doesn't freeze. But most of us do freeze. The trees and the large shrubs, which stand up through the snow, freeze through and through. When we are frozen we are sound asleep. There is nothing else doing."

"It is when the temperature is just above freezing that things begin to happen. One gets numb and relaxes, and dozes along in serene half conscious happiness, like a boy on a visit, waking up in a new and strange bed, comfortable, contented.

"When the storage for the winter is first completed the various materials are in special compartments. The starch, for example, is in starch cells, where it is held tight and sound. But when our live parts get cold and numb everything begins to leak, I guess. At any rate, all through the Indian summer the starch had remained in stubborn solid grains which couldn't be used in making new growth, but now something was coming in contact with these grains which dissolved them and turned them into sugar. Apparently there had been a leak somewhere.

"Oh, the starch, and the cold, and the sugar! Most people think the sugar maple has a monopoly of the sugar business in this neighborhood, but the fact is that nearly all of us plants are making sugar out of starch whenever there is a thawing day in winter time. Even a potato gets sweet if it is down at nearly freezing for a month or two. The sugar maple hasn't any sugar in the fall. It is simply gorged with starch. You see that maple over yonder? Last January in a warm spell a squirrel bit off some of its twigs, and it shed sugary tears all over the place. It makes sugar just like the rest of us, at any time during the winter when it is cold but not frozen.

"When the starch begins to change into sugar something else happens. Did you ever hear of osmotic pressure? Well, never mind. It's this way. When one of our little inside compartments has sugar in it it gets thirstier than usual. It drinks in water and



swells until it almost bursts. Indeed, it actually would burst if it didn't have a very strong wall about it. A pollen grain of Indian corn swells up and explodes if it can get a particle of pure water to drink. Try it, under a microscope.

"Well, the more the sugar develops the more we want to swell, until we get up a pressure inside greater than that of a steam engine. To tell it in words only a little different, we want to grow. We're crazy about it. We simply must grow; and that is why, when the least bit of warm weather comes, in spring, you find us bursting into bloom.

"Next Indian summer, cut some pussy willow twigs, or some alders, or some cherry branches, and bring them into a warm room, with water to drink. They won't bloom. Then try it a month later, and another, and another month, and you'll see what happens. Just try it. Do.

"Did you hear about the apple tree that was planted in Panama? It grew at a furious rate for about six months. Then it got sleepy and waited for the cold, but the cold never came and the tree never really woke up again. It grew a little at times but never vigorously, and finally it died.

"We northern plants cannot live without our yearly chilling."

As the boys went home to lunch the older one said "Perhaps it's the same way with people. Don't you remember how tired we were that year we stayed in the Canal Zone, and how we braced up in two months of cold weather after we came back? I wonder if we northern people don't need some cold weather just like the plants."

And the smaller boy said, "I wonder."

---

## The Twin-Flower

W. P. A.

Wonderful flower in hue and form!  
 Thy dainty bells,—a pair  
 Of dangling spice-cups in the warm  
 Sweet, mellow summer air.

No opulent and flaming bloom  
 That lights the tropic wild  
 Has charm for man, like thy perfume  
 Thou flawless mountain child.

Enchanted with a glad surprise  
 His eye looks down on thee,  
 Smiling beneath the clear, cool skies  
 In shade of Northern tree.

## The Wild Flowers And The Teachers

GUY A. BAILEY

Professor of Biology and Nature-Study, State Normal School, Geneseo, N. Y.

Where are the wild flowers of yesterday? What is the attitude of the school on the subject of picking them and bringing them in unsightly bunches, to fade on the teacher's desk?

Improvement of the land and the clearing up of waste patches have reduced the range of many species of wild flowers. To this we can offer no serious objection. Still there are many areas that for one reason or another will be allowed to produce just such a crop of native plants as conditions justify. These will be the places that a large number of out-door people will have to use in common with each other. They will be the picnic grounds for the children and grown-ups. Over these same areas nature-lovers will tramp for birds, wild flowers, ferns, mosses, insects and all the various forms that draw people from the sheltered life of office, school-room and library. They will be the oases for the pent-ups. As time goes on the number of the visitors will increase while the number of such breathing places will be diminished. Each year sees an increase to an already long list of out-door people. Unless more care is exercised by those who now use these places a large amount of the material that makes them attractive will be destroyed and only the bare places left for succeeding generations.

There seems to be a sort of sequence in the disappearance of the flora and fauna of those regions over which civilized man roams at will. As far as the flora is concerned there is some variation in the order of disappearance. In places where trailing arbutus grows naturally this species seemed to be the first to go. Its manner of growth and short stems call for the pulling up of the entire plant by those who place immediate pleasure first in their code of ethics. The result is that this delicate spring flower is pushed back and away from the cities and villages to remote hills where it is still being pursued with a perseverance worthy of a better cause. Even now as far as the majority of this generation is concerned it is exterminated. When a flower occurs as sparingly as does this little plant it is time for all to refrain from picking it and allow the plant to regain some of its lost ground. What are the school people doing? If a boy or girl can bring arbutus in from the country how eager the teacher is to wear a piece in her waist and many of the children can also boast of a little sprig of this much perse-

cuted little plant! Isn't it time for the teacher to stop to explain what all this will lead to before its actual extermination confronts her?

Another plant that has been pushed back to the regions where few travel is the pinxter or wild azalea. Its delightful fragrance has long since been but a memory in many wood-lots and along roadsides! To whom shall we look for the cause of this? In the past teachers failed to teach the lesson of restraint when it was necessary. They preferred to share with the children the fleeting pleasure of a handful or armful on the desk—just for the day. And each year saw less of it to break away; then the time came when there was none,—none for a generation more capable of appreciating its natural beauty than the thoughtless generation which, unwittingly, put out of existence one of the most beautiful of wild flowers. Then there are the wonderful orchids! Where is *arethusa*? Have you any? Then try to save it. It is worth going to see. It is worth going a long way just to see. Take along your camera and get it that way. Leave it on its stem that another, journeying with a camera, will have the same opportunity that you have. Where are the moccasin flowers? There are a few of them left but they are growing less in number and will continue so to do until there is a change in sentiment in regard to picking them. Why should the most beautiful flowers be picked and exterminated while the weeds thrive on with no one to molest them? What a fine thing it would be if those who pick should suddenly decide on the weeds and visit them with the calamity which now threatens those flowers we all want to save!

The list of threatened wild flowers can be extended for there are many on the verge of extinction. What is to be done? Really, when is a wild flower a flower? The best answer I know is the one which says that a wild flower is a wild flower only when it is growing on its stem in its natural setting. It needs all the woods, and the trees and the soil and the air to make it a real wild flower. Bunches of wild flowers packed together and set in a vase are not attractive to people with good taste, but only appeal to a crude appreciation. Even if they were thus really attractive, it would be a most extravagant way to exhaust the beauties of the fields and woods.

If we would have succeeding generations share the pleasures we derive from a walk in the woods, it is necessary that teachers take the lead in giving boys and girls a proper conception of wild flower appreciation.



## The Spring Wild Flowers

The Beginning of The Trail From Notes "On The Trail of The Wild Flowers."

LUCY L. STRATTON

Erie, Pa.

It is a great pleasure to present to the readers of THE REVIEW this charming and intimate account of the spring wild flowers from one, who now at the ripe age of eighty, is still working with them and loving them. Mrs. Stratton has sketched and painted over 1300 species of wild flowers and has her sketches classified and arranged botanically, a personal and glorified herbarium; and she is still painting and writing, a beautiful and inspiring example of what the companionship of plants will do in keeping youthful the body, mind and spirit.—THE EDITOR.

The valley of the Connecticut on the Vermont-side—an upland farm a mile from the valley—the farm half valley and half hill—the hills half wooded and half tilled—all watered by a brook sometimes in a glen almost Alpine in its wildness and inaccessibility, sometimes meandering through a flowery meadow; a lovely view over into picturesque New Hampshire upon the near Moosilank and the not distant Franconia and Presidential ranges:—such was the setting of the over a hundred years old farm house where toward the close of the last century, a summer was spent by the writer and the scheme conceived and commenced of securing and drawing in

water colors the flora about me there and wherever thereafter I might chance to be.

All around the house were stately elms spreading their branches with dignity graceful yet benignant over the mossy roofed old buildings and standing as guard each side of a grassy lane leading down to the west to the brook and meadow beyond the brook, the elms barely giving way to the brook and rustic bridge over it and beginning again with undisturbed stateliness on the other side.

Jean Paul says if you would be happy make a collection of something; but Solomons' supplement was found indispensable at the outset in collecting and painting wild flowers. Solomon says "The slothful man roasteth not that which he took in hunting, but the substance of a diligent man is precious."

It was not enough to hunt up and down that wild glen as I did every day in the early spring, sometimes on one side of the roaring brook sometimes on the other, crossing it on trees fallen across it or stepping from stone to stone, a precarious footing, searching for the first spring flowers. That which was caught in hunting must be "roasted"; must be carried home unharmed, placed in water and drawn and painted before it withered. In short the substance must be taken precious care of with the utmost diligence or hunting was of no use. Little or nothing was taken in April, however, which was cold and stormy, though with newly aroused ardor the hunting was carried on unweariedly.

But one of the first days of May, growing near or partly in a lingering snow bank, on the wooded hill east of the house between it and the river the beautiful trailing Arbutus (*Epigaea repens*) was discovered and with that my first campaign "On the Trail of the Wild Flowers" set merrily on.

If you have never found the trailing arbutus growing in its own wooded fastness in early spring, if you have never scraped among the winter covering of dead leaves and seen the bunches of grateful blossoms peeping up at you smiling and blushing in their virgin beauty when there was scarcely another green not to say flowering thing on the face of world round about, you have missed one of the sweetest joys my memory cherishes. We used to clamber down a steep bank above a river when small children and find such charming bunches of Mayflowers—no joy can ever be quite like that. Never shall I forget the delight each cluster gave us, as we liberated it from its covering of dead leaves—how it seemed to us as if the

clusters leaped for joy from their winter imprisonment into our eager hands.

A whole troop of flowers followed at once the lead of the arbutus. The delicate spring beauty (*Claytonia virginica*) was indeed the very first flower found and as such it stands the initial specimen of my collection. Early in May in the glen high up the brook appeared those showy three-rayed stars the white and red trilliums, also dearly loved flowers of our childhood. What cared we that they were not sweet-scented as we eagerly plucked them till our little fingers could not clasp another stem. Then the yellow adder tongue, yellow violets, wild oats, blood root and many others kept me busy every morning "roasting" that taken in hunting the previous afternoon.

In the field toward the east there were large patches white as snow of *innocence*, (*Houstonia cærulea*) that pigmy Alpin-like flower scarcely two inches high, and the swampy ground south of the field was yellow with the marsh marigold, or cowslips (*Caltha palvestris*). One can but feel a kind of pity for this pretty spring flower which with all the beauty of its gay, golden sepals and large shining oval leaves has begged the English language in vain for a true name. Though often called marsh marigold it is no marigold nor related to that family and it is no more a cowslip than a marigold. It does not seem, however, to mind in the least the ignominy of these borrowed names but embellishes swamps and ditches with its golden cups early in May.

For these first weeks on my "Trail" (which has proved to be a long and devious one) all was fish that came to my net; no matter how common or insignificant the flower it was new to my pencil and must take its place in my collection.

The wood anemone, the blue, pink and white blossoms of the hepatica, the buttercup—even the dandelion, the first one found sat for its picture—its leaves still too small for pot greens.

The first dandelion blossom of the season always reminds me of a little incident I once heard related by the Superintendent of the Hartford Asylum for the insane; how having plucked one in his walk, the first of the season he had seen, he held it unconsciously in his hand when he was called to help subdue a raving maniac, a woman who was smashing everything possible in her room and whom no one dared approach; how unlocking the door he went in and reached out toward her his hand in which he held the dandelion



The Spring Beauty.

blossom; how she looked at the flower an instant and said "Did you pick that for me?" and burst into tears completely subdued by the simple little flower. This story gave the blossom for me the title of nobility which it has always retained.

One of the dearest of the spring trophies was the little twin flower (*Linnæa borealis*) a veritable Alpine flower growing in the moss in New England woods, two little pink cups always nodding on one stem with a delicate perfume perfectly in harmony with the delicate beauty of the *twins*.

Though for many years interested more or less in the study of wild flowers it was surprising in this new alertness, this collection greediness how I discovered every day something new which I had walked over all my life, so to say, without noticing. One of these the little *Veronica serpyllifolia*, smallest of the small family of the speedwells perpetuates in my collection the white lie which in the demands of science must be confessed. As every botanist knows, the tiny monopetalous cups of these veronicas are most deciduous and fall when a few hours old at the slightest touch from the stock. Charmed with the tiny, violet-like wayside blossom, hitherto unnoticed, I carried it home and placed it in water to paint next

morning. But lo! in the morning every blossom had dropped off and lay floating on the surface of the water. They were all perfect, however, and it seemed quite right and an easy thing to do to paint the little plant and put a flower at each place where it belonged, copying them as they lay on the water. They had to be turned over face up and it went on finely—only as I discovered afterwards I put every flower wrong side up, the largest, lavender striped petal belonging above instead of below as I painted it!

As the days grew longer and the sun warmer bolder and more brilliant flowers appeared. Champions of this movement were that pert, little, black parson Jack-in-the pulpit and hobnobbing with him without color prejudice the pale and graceful false lily of the valley, *Clintonia borealis* daring to be false face to face with his reverence. There was a wood path leading I know not where (that is the charm of a wood path the no end of possibilities as to where it may take you and what you might find if you were to follow it long enough) a widish, grass-grown, shadowy path leading up in the hilly woods to the east and each side of it as spring advanced was a flower garden where I revelled for many a day before its treasures were exhausted. One day—where to the left of the wood road was a deep glen—I shall never forget how a bit of lovely rose color caught my eye and beckoned me to the glen; how I sprang down the steep bank and found that orchid loved and coveted of botanists, the pink lady's slipper, (*Cypripedium acaulis*) not one but many, here and there one, all around. Near them the ground was covered with the shining leaves and quaint flowers of the fringe polygala, the largest species of the polygala family I have found. By the side of the path or in it the northern columbine (*Aquilegia Canadensis*) sent up its shafts of red and yellow blossoms while all around the ground was dotted with the white four-sepaled flowers of the low Cornel or bunchberry—a bunch of red berries when ripe—sweetish and harmless—not quite so good as they look as every child knows. Still more deceptive than the fruit is the flower—this large white four sepaled flower being in fact not the flower at all but a showy involucre around the minute real flowers that bear the berries.

And each one of these countless wood flowers—a thing of beauty that would have graced the garden of a mansion growing here in careless profusion to grace a forgotten wood path where nobody every went! Ah! do not be too sure of that! Somewhere away





Bloodroot.

up and over that hill in some secret place of the woods there might be for ought I knew a fairy grotto and troops of fairies led by Titania may have danced up and down this grassy path on spring moonlight nights; may perhaps have sown the seeds of the flowers so in due time to enjoy them. The *cui bono* question began to puzzle me early in my wild flower pursuit and has puzzled me all the way on (Darwin not being the least relief to me) and of the many solutions I have given myself this first one suits me as well as any. For in a way I believe in fairies. Who am I that I should set limits to the creative power and will of the Author and Giver of all good things, denying the existence of what I cannot comprehend and see! By day and by night everywhere from the farthest star on the outskirts of the universe to the tiniest mosses on which I tread I know there is life, life, life, and the varieties are as infinite as their Creator. Go on then imagining, Grimm, Anderson, poet, story teller, whoever you are, all the new phases of life you will, you never can approach the reality.

By the end of May the lilies of the field and mountain (though they toil not nor spin) blazed out splendidly, the former nodding, the latter looking the midday sun straight in the face and that is doubtless why they blushed so scarlet. This mountain lily stood

at intervals a scarlet sentinel by the side of my wood path; the meadow lily beckoned to me from the meadow below as I strolled down the western lane, a whole troop of them tall as my head and sometimes eight or ten lilies nodding on one stem. Their orange petals had taken the sun in spite of their drooping till their maroon freckles made work for me in copying. Farther out in the meadow where unless the weather was for a long time dry, the roots of the rough grass were immersed, searching one day, in rubber boots, I found hidden among the grass roots several minute flowers that set me to wondering again of what use they were. There was that smallest of the St. John's wort family, two or three inches high with its little yellow blossom, and the curious (*carnivorous?*) little sundew with its pretty rosette of tiny round leaves fringed with red hairs and its very small white flower on a stem scarcely two inches high. Why were these curiously wrought and beautiful things hidden here where one, even a fairy, might live a lifetime on the farm and never find them? Perchance some little being inconceivably small has, with his family, his home in the tremendous shelter of one of these fringed leaves and is happy, and the erect stock two inches high topped by two or three white blossoms may be the beacon to guide him back home when he travels far away—a foot or so. How do I know?

One day early in June came the report that *Cypripedium spectabile* was in blossom. Up to that time in my life I had existed in some way without knowing there was such a flower. That Orchids were an irresponsible race, that you were never sure what they might take it into their heads to do in the way of beauty or oddity to surprise you I had already learned but as yet had become personally acquainted with none but the beautiful pink lady slipper *Cypripedium acaule*. The *Spectabile*, the queen of slippers, should be seen growing in its proud beauty to be appreciated. In blossom it stands from two to three feet high the stalk sheathed with its large clasping leaves almost up to the flower which rears itself in truly regal grandeur clothed in white and purple, by far the largest and noblest orchid growing wild in these latitudes.

And now as if following their queen the whole floral world seemed to blaze out till one must think nothing more in the way of blowing could possibly be done. Oxe-eye daisies, black-eyed Susan, Queen Ann's lace, blue vervain, yarrow, fire weeds, rock saxifrages and innumerable others covered all the fields, hillsides, roadsides, brooksides till there really was room for nothing more.



## Ho For Hepaticas!

HARRY G. BULL

And now bring in the hepaticas; they are yours for the taking. Do you remember where the prettiest ones grew last season—the pinks and lavenders and blues? Then that's the place to go, now's the time, and the snow is already melting. Take along your hatchet to chop the frozen ground with, for you'll want a good-sized handful of earth with each plant.

Look for the largest clusters of last year's leaves, all red and green and brown, and pressed flat by the heavy blanket they have been sleeping under all winter. Then look again, and closer: way down in the middle, cuddled together like "a small wee furry nest of root-mice," are all the furry buds, asleep. Be sure you get good plants with plenty of buds—the woods are full of them, so its no robbery—and you will have a fuller bowl of blossoms later.

Take up four or five plants, and don't forget the dirt. Crowd them together in a shallow flower bowl or box. Let the warmth of your home or schoolroom play the part of April air, and a sunny window attract hot Titan's beams; water them once in a while,

and—sh-h! in less than no time the sleepy babies will feel the touch of your artificial Spring and begin to stretch their sleepy arms. Out they come, farther every day, at a surprising rate, until suddenly some morning you will find them at full length, with a beauty in every hand. Presto! Spring is here, though the robins are still looking for worms in Baltimore and the bluebird has yet to sing as he flies along our fence posts.

After the petals have fallen the downy leaves will appear, and as the real Spring arrives you can set the plants in some friendly corner and they will bloom again next year, none the worse for the trip away from home so early in their infancy.

### An April Stanza from "Spring Rivulet"

From *Wind and Weather* by L. H. Bailey

Through the pastures high  
 Now free of their snows  
 On gray matted sod  
 The rivulet grows,—  
 Dips under a root  
 Falls over a stone  
 Slips under a bank  
 With a muffled tone,  
 Shines out in the sun  
 Then sweeps round a knoll  
 And spreads clear and still  
 In a weed-edged bowl.  
 It drains the mud slews  
 In the fields of wheat  
 And lays down the silt  
 Where the currents meet.  
 Bubble and bubble tumbles the foam,  
 Grasses and twigs will find a new home.

Oh robin, my robin, you are with me again:  
 The sap's in the maple and the wood-twigs are bright,  
 The fence-rows are waking and afield are the men,  
 The March-winds are roaming and the willows are white.

# THE NATURE-STUDY REVIEW

DEVOTED PRIMARILY TO ALL SCIENTIFIC STUDIES OF NATURE IN  
ELEMENTARY SCHOOLS

Published monthly, except June, July and August. Subscription price, including membership in the American Nature Study Society, \$1.00 per year (nine issues). Canadian postage, 10 cents extra; foreign postage, 25 cents extra.

**Important** Please note date of expiration of your subscription on the label of the wrapper. Subscriptions must be paid in advance to comply with postal requirements. Subscriptions and advertisements should be sent to *The Comstock Publishing Co., Ithaca, N. Y.* Manuscripts for Publication and Books to be Reviewed should be sent to the Editor.

---

## Editorial

WHITE OF SELBOURNE

The Editor has a leisurely feeling this morning, although no cog has slipped in the routine machinery of her day that turns out a duty for every hour with clock-like precision. The reason for her delectable state of mind is that she has been reading with her senior class in Nature-Study the writings of that first great exponent of our cult, Gilbert White of Selbourne, England. He had all the time there was in his days; and there is no note of hurry in his wonderful letters, so full of what he saw in his garden and during his strolls in the country round about. Time to see, time to think about what he saw, and time to write to his friends about what he saw and thought, what an ideal life!

Gilbert White was a man who was interested in the world and wished to see it; but instead of setting out on a journey to see it, he sat down and saw it. Other men of like mind, travelled in far away lands, around about the globe. What did they see? Mountains, valleys, birds, animals, insects, trees, plants, rocks, fossils and different kinds of men. Gilbert White stayed at home in his own dear English nook, and he also saw hills, valleys, insects, trees, plants, rocks, fossils and different kinds of men; and he saw them far better than most of those who went abroad to see. Not only did he see, but he thought about what he was seeing and tried to place it in its right relation to the rest of the universe. What he saw meant something fundamental to him, and to his friends. Had it not been for his friends we should never have known aught of Gilbert White; he wrote letters to them constantly containing

delightful and detailed descriptions of what he had seen of importance in his world that week or yesterday.

His interests were as varied as his talents; one letter may contain a poem, the next a study of the swallows or some other birds, the next a description of some fake, like the curing of cancer by toads, the next, an account of archeological treasures unearthed in the neighborhood or a sympathetic study of Timothy, his pet tortoise. We know only incidentally what his friends wrote to him, but as long as our language stands, we shall know what he wrote, for what he wrote is as fresh and vivid to-day and even more interesting than it was when it was penned more than a century and a half ago. What he could describe better by making drawings, he recorded in this manner, making ideal illustrations for text.

If there is anyone like Gilbert White left in this busy modern world, who has time and inclination to see, think and write and who has leisure for contemplation, the Editor would be profoundly grateful to be informed of the fact; she would make a pilgrimage and look at him from afar, through field glasses, so as not to disturb him and then she would come home and announce the glad tidings to the readers of *THE NATURE-STUDY REVIEW*.

#### THE PEACEABLENESS OF NATURE STUDY.

The Editor is a peace-loving person, coming from Quaker stock, and never has the study of the birds, trees and flowers seemed so sweet and comforting to her as since this war carnival has been drenching European soil with the blood of her bravest sons. In fact, the little brethren of the fields and woods have been about the only companions able to beguile the mind to forgetfulness of the stupendous calamity. Because of this there has come a new sense of the importance of giving to the rising generation this power to find companionship in the study of life out-of-doors; for it has ever been a source of strength to those possessing it.

Gilbert White lived and saw and wrote during the American Revolution and when England was at war with France and Spain also. But no word of these struggles finds its way into these wholesome, serene letters to his friends. We cannot doubt that he was deeply stirred by the events of his time; but he had learned that when he placed his hand in that of Mother Nature, he could afford to forget his anxieties and yield himself to the comfort of her companionship.

## The Teacher's Corner

There is a special charm in the study of the spring flowers which is lacking later in the season when we have forgotten about winter in the wealth of summer blossoming. The topics selected by the writers of THE NATURE-STUDY REVIEW this month are exceedingly interesting as special subjects for study.

*The Lady's Slipper or Moccasin Flower.* The observations on this flower should consist in the following: Describe and sketch the leaves showing how they join the stem and whether they are alternate or opposite; describe the sepals and their position in relation to the flower; note that there are three petals, the middle one of which is very different from the others in form; describe the petal sac, the entrance to it, the color around the entrance to attract the insect; the exit and the reason why an insect would not be likely to come out by the same door that it went in; note the two roundish bodies which project into the openings of the sac at the exit, thrust a pencil against the underside of one of these and note that the pollen comes off "in a plaster"; cut away one side of the petal sac and find the stigma; describe it and its situation with relation to the anthers and to the exit through which the insect crawls out; note how the bees visiting the flowers one after another may carry the pollen of one flower and deposit it upon the waiting stigma of another; describe the seed capsule from the outside, cut it across and note the arrangement of seeds and how the capsule opens to let the seeds out.

*The Skunk Cabbage.* I know a place by a tiny lake where a cold spring wells out of a tree-covered bank and feels its lucid way past the root-stalks of staunch ferns and around mossy logs until it reaches the water below. Near-by it the crinkle-root and miter-wort blossom and the adder tongue and trillium shake their nodding bells, and a little at one side of the spring, between it and the lakelet, grows a mass of great, spreading, bright green leaves which make the nook look most tropical. Surely we plant near our ponds many things which are not nearly so beautiful or luxuriant in foliage as is the much despised skunk cabbage. It was this very spot that Mary Rogers Miller describes in her delightful Brook Book, where she discovered that the skunk cabbage not only blossoms earlier in the spring than other flowers, but that it is able to germinate enough heat to thaw for itself holes through the snow covering; she says characteristically, "I like hardy folk—people who can germinate their own fires and do work in spite of everything. Skunk cabbage is just such a sturdy citizen." A study of this sturdy citizen which blossoms before the hepatica, and even before the pussy-willow lifts its soft fur, will make for us an interesting page in Nature's book.

Observations on the Skunk Cabbage: Where does the skunk cabbage grow? Have you discovered that snow melts quicker above the skunk cabbage than elsewhere in its vicinity, if so describe it! Do the flowers or the leaves appear first? Show by sketch how it looks when it first appears above ground? What is the color of the spathe? Does the spathe change its shape as it grows older? Describe the spadix and the flowers both in color and form. Do all the flowers mature at the same time? If some of the stamens mature before the pistils tell on what part of the spadix they grow. How early do you find skunk cabbage in blossom in your locality? When do the leaves appear?

Sketch the leaves as they look when just starting. Take one of these leaf buds apart, leaf by leaf, and note how compactly nature does up her packages. When does the fruit mature? Does the spathe remain after the fruit is mature? How does the fruit look when matured? What is the use to the plant of its odor? What insects do you find visiting the flowers? If possible, study the roots of skunk cabbage and describe how they are fitted to live in the places where the plant usually grows. Compare the skunk cabbage with the Jack-in-the-pulpit and the calla lily. Why do you think these plants are related to each other?

*Adder's tongue.* This plant should be studied in the woods, notes being made on it there; but a plant showing the corm, roots, leaves, and blossom should be brought to the school house for detailed study and then planted in a shady place in the school garden. The following points should be observed: Where the adder's tongue grows, how early its leaves appear above the ground, and the date of its first blossoming; the number of leaves on each plant and their colors; do they remain mottled as they grow older? Do the plants occur singly or in patches, why do they grow so many together? How far below the surface of the soil is the corm? How does this differ from a bulb and of what use is it to the plant? Note the shape of the flower, the three sepals are petal-like but they are sepals just the same because they protect the bud; note the lobes on the base of each petal, note the flower is bell-like and its clapper is made up of pistil and stamens, note that the flowers close on dark days, when there are no insects to visit: describe or sketch a stamen and pistil; describe a seed capsule and the seeds within it.

*The Hepatica.* This is perhaps the best loved of all the wild flowers and the plant may be potted early and its blossoming watched in the school room. The following points should be observed: That the hepaticas always grow in woods but not in open fields; note the color of the leaves in early spring and sketch them in color: note the young leaves that come up late in spring, that they are covered with down; describe the flower bud, the stem and the three little blankets that hold the bud, which are really bracts and not sepals; note all the colors of hepaticas; do the flowers remain open in dark weather and stormy weather? Note how they close and bend in a snow storm; do they remain fragrant? Note that after their stigmas are fertilized the flowers remain open in dark weather and are not fragrant and explain that this is because they no longer need to save their pollen and induce insects to visit them; note that the three outer petals are really sepals in position and act like sepals, when the flower closes, although they look like petals; note the long stamens with the greenish white anthers and the many pistils at the center of the flower, each pistil holding up a little whitish stigma, and that each pistil produces one seed; note that the three bracts remain to protect the seeds when ripening.

*The Columbine.* While the form of the columbine flower may be studied in the school room yet the observations of the changes in position of the anthers from day to day and the actions of the insect visitors should be made in the fields. Note that the columbine has five petals which form nectaries; there is a sepal between each two nectaries which is of the same color as the petals and adds to the beauty of the flower; the flower droops and hanging below it are the stamens, and the stigmas; there are many anthers and when unripe they



are fat, yellow and globular; each anther has a short filament which curls up at the tip and holds the stamen up; but when the pollen ripens, the filament straightens out and the opening anther hangs down below its unopened comrades, but never so far down as the stigmas; note that each day a few more stamens straighten down; note that there are five stigmas tipping the thread-like styles each of which leads back to an ovary filled with ovules. The whole

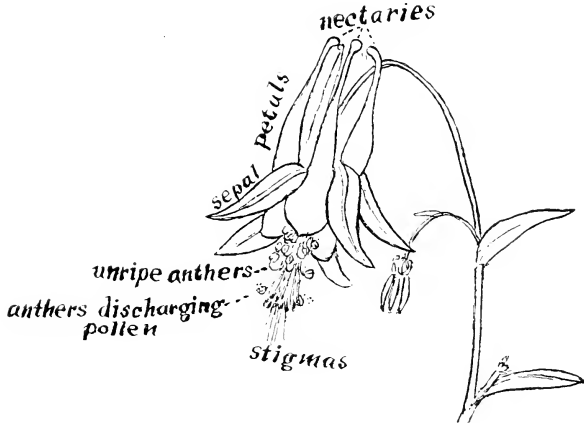

process of shedding pollen should be watched, and also the hummingbird and insect visitors and their actions in getting nectar from the flower; note that the columbine buds are at first all green and describe the changes that take place until the flower blossoms: describe and sketch the seed capsule with its five pockets each with an opening near the tip to let the seeds out; note that the lower leaves are three-lobed and the lobes are lobed; and the upper leaves are simple and bract-like at the bases of the flower stems; have the pupils describe all of the kinds of columbines that they know.

---

## April

### PHOEBE BIRD

Gaunt forests, misty green with young leaves, seem

Reflections pale of emerald fields below.

Athwart their depths, white shad-bush pennants stream,—

Fair springtime dreams of branches hung with snow.

## News Notes

The report of the Commissioner of Elementary Schools of California is at hand and is very interesting. California has a live wire in its Commissioner of Elementary Schools, Dr. Margaret Schallenberger McNaught. She has under her charge 432,562 pupils and they may be counted fortunate. Among the bulletins edited by her for the state is one on good manners. Realizing the difficulty of teaching manners and morals, subjects which are required by law to be taught, this bulletin was written by Dr. McNaught and should be in the hands of every grade teacher in the United States.

In northern California, the work of introducing the nature-study field excursion into the schools has finally met with the same success as the campaign to introduce manual training and domestic science. They now have these field excursions just as one sees them all over what might be called the "fair complexioned" part of Europe.

On Burbank Day, March 7th, a newspaper campaign was started by the Sacramento Bee for the purpose of eventually organizing Audubon Societies at some 150 points throughout the Sacramento Valley. The first part of the campaign was devoted to birds; the second, to tree planting for supplying bird refuges, as well as for replacing the losses of the primeval trees of the valley floor. Sets of the Mumford Colored Bird Prints are being supplied to each of these 150 centers by Mr. C. M. Goethe of Sacramento. This campaign will be followed by systematic work throughout the year.

A circular has been issued by Dr. A. H. MacKay, Secretary of Public Instruction of Nova Scotia, to be handed to each teacher in the Province. This circular outlines nature-study observations and gives tables to be filled in by the teachers and returned to the school inspector. These tables ask first for the general topographical and geographical conditions surrounding the school; then gives a list of 52 wild plants and 13 cultivated plants, asking when the blossoming of each is first observed and when it becomes common. Information is also asked for the date of beginning certain farm operations; also record of the meteorology of the region. The time of spring and fall migration of 18 birds is asked for; also the dates of first piping of frogs and appearance of snakes. This circular should be the means of collecting very important data.

A committee of leading educators has been formed for promoting physical education in the public schools of the United States. This committee holds that, "physical training rather than purely military training is desirable." Account of the work of this committee may be had by sending to Mrs. Harriet P. Thomas, Room 647, Munsey Bldg., Washington, D. C.

From Clayton F. Palmer, Superintendent of Agriculture in Los Angeles, California city schools, comes a very interesting report on the garden work in that city. Two acres have been made into gardens, which are used as a center

for teaching, inspiration, and the growing of plants for distribution to other schools. The forty teachers who conduct the garden work in the elementary schools meet at this center once a month for conference, instruction, and plant material. Connected with this garden is a bungalow for collections, laboratories, and class room, a lath-house, potting-house, propagation yard, composting yard, and a model home is to be constructed. In the garden itself are plots for wild flowers, iris, vegetables, bush fruits, fruit trees, grapes, etc., also a rockery, and water garden. When all this plan is finally realized Los Angeles will have an ideal center for conducting city garden work.

The people of Portland, Oregon, are making ready to give the teachers of the N. E. A. a cordial welcome. A rose carnival is to be held for their benefit and every teacher will be given a rose bouquet every morning of the meeting; or if she prefers, the teacher may clip her own roses, and "the bathing pavilions will furnish a rose for the hair of every swimmer."

There are many interesting trips to be taken from Portland as a center, and those teachers who are fortunate enough to attend this meeting are sure to have the time of their lives.

Dr. R. W. Shufeldt sends the following news notes on Nature-Study in the public schools of Washington, D. C.:

For many years past I have been much interested in the matter of the development of the observational powers of boys and girls, in their school and home training, to begin as early in their childhood as possible. Malobservation on the part of individuals of either sex, at any age, is responsible for more misunderstandings, defective education, criminal acts, and general misery and unhappiness among us, than all the other causes in the world put together. We have not far to seek, at any time, abundant evidence to sustain this statement. When malobservation is combined with gossip, it often results in the severance of friends, and in breaking up of families. It has the power at all times to fill the literature of science of every description with error, to be passed into schools of education of every grade and description; and it may be the cause of losing everything or anything, from a case of infantile paralysis to the most momentous battle fought in the history of mankind. Indeed, there is no end to what malobservation may be responsible for either in private or public life. For this reason we should do all in our power to properly develop and train the faculty in our children, at every stage of their education, in the matter of *seeing*, and *seeing correctly*, and when the proper age is arrived at to *report truly*—that is, to write out correct accounts of what they have seen.

Nature-study, when properly incorporated into the educational scheme of children, in the family and in the schools, constitutes a method that is amply able to effect what we aim to accomplish along such lines, and accomplish it most thoroughly. These facts are so well known to the best of our teachers of children throughout the country, that it will not be necessary to occupy further space here touching the matter at this time.

Recently, Miss Cora A. Smith, News Editor of THE REVIEW, has requested me to report upon what is being done in such directions in the Public Schools of Washington, D. C. In taking the initial steps toward gaining the necessary

information in the premises, I communicated with Miss Susan B. Sipe, teacher in the James Ormond Wilson Normal School of this city, one of the best equipped of all our Public Schools. Miss Sipe most kindly and very promptly responded to my application for information. As the teacher in the Nature-Study Department, Miss Sipe "requires every student to take at least one walk in the country each month and make observations at the same time. As most of them have done nothing of the kind before in their school life, they have difficulty in seeing. They are improving from month to month. I also encourage the feeding of birds by the students who live in the suburbs. The two papers I am sending you show the endeavors of one of them." The two papers referred to are reproduced *in extenso* below.

Miss Beard being a student in the Normal School, is, of course, a young lady grown. These two examples of nature-study observation are dated 23, 1916 and January 28, 1917. The latter is a most interesting contribution December and is entitled "A January Walk in the Country," and the former "A December Visit to my Bird Tables." Both papers are in evidence of excellent powers of observation on the part of their writer, and they show marked improvement when we consider that they were written less than a month apart.

#### A JANUARY WALK IN THE COUNTRY

The world was covered with a soft white blanket last night and when I went out the sun had sprinkled it with myriads of diamonds. But I did not go out to look at the beauties of nature, I went out seeking facts. Since nothing was to be seen on the ground but snow, I went to the woods to find my facts. As I walked along I looked at the buds on the different trees and I found that many of them are much larger than they were when the leaves first fell off, especially those on the hickory, tulip magnolia, silver poplar, Judas tree, and dog wood. The little round, flat buds on the dog wood were all holding tiny candles of snow. These round buds are the ones which will make the flowers next spring. The leaf buds are still very tiny. In the same way it is only the buds that will make the "cat-tails" on the silver poplar, which are so large now. The leaf buds are still very small. The buds on all kinds of oaks, willows, black walnuts, elms, and maples are still as small as they were early in the fall. It was very easy to tell which oaks belong to the white oak family because they still have a great many of their leaves sticking on their branches. The pine trees all had their needles drawn closer to their branches than they are in the summer and the tips of the branches had tiny snowballs in them. I looked in the clusters of needles at the end of the branches to see whether the young shoots had started to grow and I found that they had not. Most of the berries have fallen off of the cedar trees but I looked on the tips of some of the branches and I found the tiny little waxy balls which will make the berries for next year. They were not any larger than a pinhead. These were only on the trees which had berries on them. On the other trees I found little yellow scaly looking balls which were about half as big as one of the blue berries. These are the buds of the staminate flowers. The trees which bear the berries do not bear the staminate flowers. As I crossed the creek at one place I noticed that the tails on the alder and hazel bushes seemed to be longer than they were in the fall, and they are not so dark in color.

Since I can tell the names of all of the trees around here by their bark, I am teaching myself to know them from a distance by the way in which they grow. You may not think this is possible, but it is, because I have found that no two different kinds of trees hold their branches in the same way. I have made it into a game which I rather enjoy playing as I go through the woods. This is the way I do it. I pick out several trees while I am too far away from them to be able to tell what they are by their bark, and I decide as to what I think they are, then I go up close to them to see if I was right. It is one of the most original and fascinating guessing games that I have ever played. Try it and see if you don't agree with me. I am beginning to know the trees around here so well by the growth of their branches that I very seldom make a mistake any more. For instance, these are some of the things I have learned; the branches of the black walnut while comparatively few are large and spreading and very stiff looking, even the smallest twigs are stubby and thick; the willow has slender branches which grow upward and are covered with long yellow switches; the branches of the elms bend down in the shape of an umbrella and are a soft gray in color, even the tiny little twigs (which are very slender) carry out this same scheme of growth; all the top branches of the tulip magnolia try to grow as near vertical as possible; these trees also have rather stiff looking branches but they grow so much more vertical and are so very much lighter in color that they cannot possibly be mistaken for black walnut. I might go on indefinitely and describe any number of trees in this same way without mentioning their bark so you see I am learning a few things out of school simply by observation walks.

PEARL BEARD

---

Miss Beard's report on her visit to her bird tables will appear in the Bird Number of *THE REVIEW*.

## The Book Shelf

*Messages of Good Cheer*, No. 1 and No. 2, by The Trotty Veck Messengers, Saranac Lake, N. Y. The two numbers mailed for 20 cts., twelve for \$1.00, not sold separately.

These tiny booklets came to the editorial desk a month ago and have established there a permanent place of their own, where a momentary glance at one of their messages may gladden an hour and replenish editorial courage. Trotty Veck was a weak, spare old messenger described by Dickens in the "Chimes," but he was strong at heart and of good cheer and had entire faith in his ability to deliver messages. The Trotty Veck Messengers are two young men who are obliged, on account of ill health, to live at Saranac Lake and who, instead of giving themselves over to the boredom of convalescence in exile, have gathered together enough cheerful messages to make two booklets, each worth its weight in gold to anybody who can read. The messages are quoted from poets, philosophers, noted writers, with here and there a few words from the Messengers themselves, such as: "Your friend is the man who knows all about you and likes you," "How to make a shadow: stand in your own sunshine," "Even a tombstone will say good things of a fellow when he is down," "Don't Grouch! smash a window or a chair or take a cold plunge, anything to get it over with." The No. 1 booklet is entitled "Good Cheer," the No. 2, "Be not afraid." These young men surely are living up to their principles: "When you reach the mountain top, wig-wag courage to the fellow in the foothills," and we hope every reader of *THE REVIEW* will send 20 cts. and receive these two little treasure caskets of cheer.

*Poultry Breeding and Management*. By James Dryden, Professor of Poultry Husbandry at Oregon College of Agriculture. Orange Judd Co. 402 pp. \$1.60.

"When man himself became tame he set about training the wild things of the forest and plain in order that he might better supply his needs for food and raiment." "To exercise his God-given dominion over the earth, man had to bring to his assistance plants and animals that hitherto existed only in a wild state." Thus in the first chapter does Professor Dryden pleasantly introduce to us the history of poultry raising and breeding. A chapter is given to each of the following topics: Historical Aspect, Evolution of Modern Fowl, Modern Development of Industry, Classification of Breeds, Origin and Description of Breeds, Principles of Poultry Breeding, Problem of Higher Fecundity, Systems of Poultry Farming, Housing of Poultry, Kind of House to Build, Fundamentals of Feeding, Common Poultry Foods, Methods of Feeding, Methods of Hatching Chickens, Artificial Brooding, Marketing Eggs, and Poultry, Diseases and Parasites of Fowls.

Professor Dryden writes in a lucid, crisp style and has his subject matter "boiled down" to crystallization. There are no superfluous words in this book which is a clear comprehensive and up-to-date treatise on the poultry industry. There are about 200 illustrations which are both pertinent and interesting.

*Modern Fruit Marketing.* By Bliss S. Brown, Professor of Horticulture in the Maine College of Agriculture. Orange Judd Co., \$1.25.

If our great grandfathers could awake from their long sleep and come back to see how we are getting along, probably nothing except automobiles, aeroplanes, and telephones would surprise them more than our present methods of marketing farm products. In their day they shook the apples from the trees, put them in barrels and carted them to the nearest town and sold for what they could get. Now the process of marketing is as complex as is everything else in our modern life,—as is well shown by this book written by a high authority; it deals with the subject of marketing fruit with a thoroughness that is noteworthy. In it are discussed fruit harvesting operations, preparing fruit for the market, fruit packing and package, the storage of fruit and its effects on it, transportation, selling agencies, and methods of selling, organizations of fruit growers and fruit shows. The book is written tersely and clearly and is profusely illustrated; it is a volume that should be in every fruit grower's library.

*The Book of Forestry.* By Frederick F. Moon, Professor of Forest Engineering, Syracuse University. D. Appleton and Co. 351 pp. \$2.00.

This volume is dedicated to young America and to Daniel Carter Beard, New York Scout Commissioner. It is written with a thought that "the best way to reach the citizen of to-morrow is to interest and instruct the boy of to-day." Part I covers the following topics: What is forestry?—what the forests do for us, saving Uncle Sam's biggest bank account, how big trees from tiny seedlings grow, properties of wood and their uses, making money out of forestry, the life of a forester, how the forest is guarded, measuring the forest crop, harvesting the forest crop, the most interesting forest products, how wood is preserved, city forestry and shade trees, the future of forestry in the United States. Part II is given over to a description of the trees and shrubs which are of economic importance and has a key for determining wood sections.

Part I has 15 interesting full page illustrations and Part II has many line drawings to aid in determining species of trees. The book is written in a simple and chatty style which will surely make it attractive to boys and girls; and it will undoubtedly fulfill the author's desire that it may "awaken the love of the forest in the heart of young America, and a realization that forestry is necessary for the comfort, health, and prosperity of future generations."

*Experimental Plant Physiology.* By Lucy E. Cox. vii + 111 pp. Longmans Green & Co., London. 1915. \$.60

The book contains directions for sixty-nine physiological experiments designed for pupils of high school age. It is particularly interesting as restricting itself wholly to physiology. It indicates better than any other manual of the reviewer's acquaintance the possibilities that lie before elementary plant physiology in our secondary schools.

As the book is of British authorship it naturally reflects some methods which are not in accord with current American practice. For instance, the laboratory directions not only give the aim and method, but also set down in considerable detail the expected observations and inferences.

The directions are clearly given, assisted by illustrations when necessary, and a number of experiments are new.





# THE NATURE-STUDY REVIEW

---

VOL. 13

MAY, 1917

No. 5

---

## Concerning Wild Ducks

ELSA GUERDRUM ALLEN

Ithaca, N. Y.

Photos by A. A. Allen

“Whither, midst falling dew,  
While glow the heavens with the last steps of day  
Far, through their rosy depths, dost thou pursue  
Thy solitary way?”

These lines of Bryant are imbued with the spirit of the wild. The poet, out in the twilight, sees the princely game bird, safe, after a day of peril, winging his evening flight to pond or lake unknown. But he cannot follow him. He can only wonder and ask:

“Seekst thou the plashy brink  
Of weedy lake, or marge of river wide,  
Or where the rocking billows, rise and sink,  
On the chafed ocean-side?”

The waterfowl appears as a beautiful mystery, stealing, from out the sky, upon the inner consciousness, just long enough to draw us, yearning, to some knowledge of its secrets, and then,—

“Thou’rt gone, the abyss of heaven  
Hath swallowed up thy form; yet on my heart  
Deeply has sunk the lesson thou hast given  
And shall not soon depart.

He who, from zone to zone,  
Guides through the boundless sky thy certain flight,  
In the long way that I must tread alone,  
Will lead my steps aright.”

Bryant’s “To a Waterfowl” has been called America’s finest short poem. Its appeal is tremendous for it sets forth, in matchless language, the reverence we all feel for wild life. It attributes to the waterfowl a sort of hallowed unapproachableness.

But had Bryant been able to follow the bird to its "weedy lake or river wide," he would have pictured for us a different sort of a duck—a duck of the earth earthy, with a short, squat body, and great webbed feet, a duck with a broad, busy bill and a glistening eye; a duck that rides the water like a cork, then suddenly flips into the wave, rising in a moment, juggling a strand of eel grass, while the beads of water roll from its back like milky pearls. Such birds one must now stir far from his fireside to see. Long persecution has made them both scarce and wary, so that, if one would know them intimately, he must follow them away to their native stretches of marsh and water, and live with them a while.

In colonial days, when this country was more or less in a state of pristine nature, the number of wild ducks, and indeed all wild life was almost phenomenal, but too soon this wealth was prodigally wasted. The early settlers doubtless thought it inexhaustible and shot, and trapped, and netted, practically unrestricted by law, until but a small remnant was left.

The Laborador duck and the passenger pigeon are now extinct, but these calamities served to rouse the country to the need of protecting birds. Good laws are at last in force, helping bird-life to regain its own. We are passing through a national awakening to the value and beauty of birds, and wild ducks, although as yet imperfectly known, and so difficult to study, are no small part of the new and fascinating field of nature-study.

Central New York is the home of large flocks of wild ducks from November to April. Most species, nest west and north of this region but they come south in the fall, the pond and river ducks continuing to the Southern States where small bodies of water remain open, while many of the bay or diving ducks stop on the Finger Lakes.

The ducks are a large group of water birds which, with the geese and swans, are classified as the family *Anatidae* of the order *Anseres*. There are two hundred species of ducks, geese, and swans, found throughout the world, of which approximately fifty occur in North America. About forty of these are ducks, the rest being geese and swans. The ducks, in turn, are divided into three subfamilies, the *Merginae* (fish-eating ducks with serrate bills), the *Anatinae* (the pond and river ducks which secure their food by dabbling in shallow water), and the *Fuligulinae* (the bay or diving ducks which dive for their food in water from five to one hundred.

or one hundred and fifty feet deep). The diving ducks can remain beneath the surface of the water for minutes at a time, probably owing to the air which they store in their five pairs of air sacs.

Representatives of all three sub-families visit central New York. There are nine species of merganser, or sheldrake, or saw-bill, as they are variously called, three of which, the American merganser,

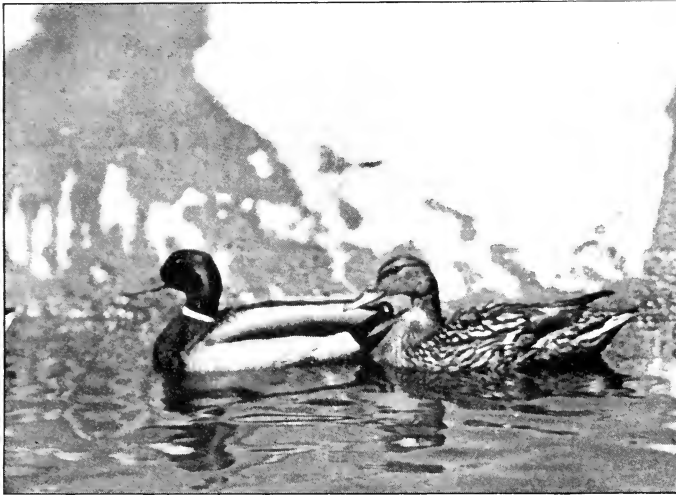

A Pair of Wild Mallards

the red-breasted merganser, and the hooded merganser occur on our lakes between October and April. The first fall migrants are the dull colored immature birds, and those in "eclipse" plumage. Later in the winter the lakes are dotted with small flocks of the bright colored adults. All the mergansers are handsome, crested birds with rather slim bodies, the males having very striking plumage. They feed on fish, frogs, crayfish, etc., which they secure by diving, and the mandibles are provided with saw-like teeth which prevent their slippery prey from escaping.

The early fall, September and October, brings in mostly the dabblers or river ducks (*Anatinae*) among which are the black duck, the mallard, the blue and green-winged teals, the pintail, the widgeon, and the wood duck. The western gadwall and shoveller rarely come here. Black ducks, mallards, and blue-winged teal, occasionally nest here in the larger marshes and iso-

lated upland bogs. Wood ducks, also, sometimes nest here in hollow trees, high above water or even far removed from it, and the ducklings, soon after hatching, drop out of the nest, collect themselves as well as they can, and follow the mother to the nearest pond or stream.

The green-winged teal, the pintail, the widgeon, and most of the blue-winged teal, black ducks, and mallards nest in the west and north, coming here only as fall and spring migrants. Their nests are rough structures, lined with down from the ducks' breasts which conceals the eggs when the parent birds go in search of food. Ducks lay from eight to twenty eggs, a provision of nature against the great mortality among young ducks, for the young maturing from a brood average only four or five. The river ducks migrate in rather small flocks, but by the time they reach their winter quarters in southern United States, especially some of the large game refuges, they combine into flocks sometimes numbering thousands.

The common winter ducks of central New York are the bluebills (or scaup ducks), the canvasbacks, the redheads, and the goldeneyes. It is not uncommon for black ducks and a few mallards also, to winter as far north as this, and, when the snow is not deep, they supplement their feeding on the lake with trips to the upland fields where they find grain and weed seed. The diving ducks (*Fuligulinae*) are, however, the typical winter resident ducks of New York State. In fair weather they usually mass their numbers into a few large flocks far from shore, but on stormy days they are restless, circling about on whistling wings, hunting a sheltered bay in which to feed.

They nest in the large marshes of northwestern United States and Canada coming south only far enough to find food. Usually the Finger Lakes do not freeze their entire length, so that these ducks have good feeding on the beds of eel grass and other pond weeds which cover parts of the lake bottom, but in severe winters, when only a few holes stay open, the local bird club and game wardens have had to take them large quantities of grain. At such times many of them become so tame that they feed close to shore, even on the shore, seeming to forget that they ever were hunted.

Their fear is mostly for motion, so that if one keeps perfectly still, he may have the joy of studying them within a few feet—their wonderful plumage, their curious calls, their feeding habits, and their constant fighting with each other.

The canvasbacks and scaups, although supposed to be very wary, are usually the first to find the feed, and, after scrutinizing the shore from every angle, they begin to dive. The water boils and churns with the multitude of paddling feet and buoyant bodies, and more ducks swim in from all directions until there is a great flock. Beside the graceful, aristocratic canvasbacks the scaups look very chubby and their beady yellow eyes set in their dark round heads give them a shrewd if somewhat uncultivated expression.

The redheads keep clanishly to themselves, diving out towards the middle of the lake, and if ever one finds itself with the more docile scaups and canvasbacks, it swims about suspiciously with every sign of being an alien. Sometimes, in the early morning, or in the dusk of evening, small flocks of black ducks and mallards come in but they too seem out of their element. Being dabblers rather than divers, they are perhaps loath to show their inexperience in deep water. They edge toward the corn and finally with much splashing and complete lack of finesse, they essay a few dives in the shallower water. These pond and river ducks dive with a little flip of their wings, as well as their feet, while the diving ducks use only their feet.

It is often all one can do to hold in his chuckles while watching from ambush on the shore, such a seething, bobbing mass of ducks, but it is imperative that he do so, no matter what ridiculous bout may be transpiring a few feet away. The canvasbacks, albeit very dignified at times, are fighters at heart. For no reason that an onlooker can discover, two birds advance gloweringly toward each other, with heads bent threateningly to one side, while each tranfixes his opponent with his glittering red eye. Then they clinch bills and struggle till one is exhausted and attempts to escape, whereat the vanquisher grabs him unmercifully by whatever part he can seize,—neck, wing, or tail,—and pursues him till his spirit is chastened.

Sometimes a pair of whistlers or golden eyes, one of the most beautiful and distinctive species, swim in, although apparently not for the corn. They are well named “whistler” for their wings make several times the noise of other ducks’ wings and, furthermore, the sound is quite vocal in quality (although of course it is made entirely with the wings), and it can be heard as far as the bird can be seen. The male often executes his curious courting figure

before the female. Stretching head and neck, he throws them clear back over his body till his bill touches his tail. Then suddenly he recovers himself uttering his characteristic call of "*Beard*" very sharply, while the female sometimes acknowledges this attention by flattening herself upon the water, swimming rapidly away with head and neck extended straight out from the body.

The notes of wild ducks are perhaps the strangest and most surprising revelation to the bird student. Contrary to common belief, there are rather few ducks which "quack." Female black ducks and mallards quack, but, even with these, there is considerable variation and the males make a much softer, subdued sound. The red heads on the middle of the lake, keep up a more or less continual calling—a loud, nasal, rather shrill "*carr*" somewhat resembling the note of a young crow, while the scaups trill low and resonantly and occasionally utter their characteristic "*scaup*." The male canvasbacks, perhaps the strangest of all, have a note which suggests a cow mooing far off in the distance. This they are able to do with the bill closed. The female canvasbacks, when alarmed, utter a very low "*quack*." Doubtless there are other notes of each species, those of the males and females differing widely.

The ducks are a large and perplexing family of birds, the more so because of the inaccessibility of their haunts, their great wariness under most circumstances, and their varying plumages. But if these fascinating water fowl each with its life history, its individuality, and its curious little marks of character that we do not expect of the animal world, could be as familiar to us as the birds of our feeding stations and nest boxes, what a wealth of new pleasure would be ours. Let us follow the wild duck to the lakes and marshes and learn its secrets.

The following key based largely on the wing markings which are conspicuous in flight is offered in the hope that it may simplify the field identification of our commoner wild ducks. Immature birds of both sexes closely resemble the females and therefore no particular mention is made of them. The various plumages of the eiders and harlequin duck have been omitted because these birds are very rare in the United States.



Canvasbacks on Cayuga Lake

## Color Key to the Ducks of the Eastern United States

*The various plumages of the Eiders and the Harlequin are omitted because these ducks are very rare.*

- A. Birds with conspicuous white in wings.
- B. White patches large.
- C. Plumage largely black and white.
- D. Plumage, except for white patches, black.  
*White-winged Scoter*
- DD. Wings and back white, head reddish.  
*Male Canvasback*
- DDD. Large areas of black and white.
- E. Bills long and narrow, heads more or less crested.
- F. Head entirely black.
- G. Breast entirely white.  
*Male American Merganser.*
- GG. Breast with dark band.  
*Male Red-breasted Merganser.*
- FF. Head with large white patch.

*Male Hooded Merganser.*

EE. Bills short and broad, heads not crested.

F. Head with large white patch.

*Male Bufflehead.*

FF. Head with small circular white patch at base of bill.

*Male American Golden-eye.*

FFF. White crescentic patch at base of bill.

*Barrow's Golden-eye.*

CC. Plumage largely grey and brown.

D. Shoulders white or greyish-white.

E. Shoulders white. *Adult male Widgeon*EE. Shoulders greyish-white. *Female or immature male Widgeon.*

DD. Speculum white.

E. Bills narrow; heads reddish-brown and crested.

F. Colors of head and neck sharply defined.

*Female American Merganser.*

FF. Colors of head and neck blending.

G. Breast whitish, larger.

*Female Red-breasted Merganser.*

GG. Breast grey, smaller.

*Female Hooded Merganser.*

EE. Bills broad, heads not crested.

F. Sides of head with indistinct white blotches, size small.

*Female Bufflehead.*

FF. Head uniformly brownish like back.

*Male and female Gadwall.*

FFF. Head uniformly brownish, back grey.

*Female Golden-eye.*

BB. Narrow lines of white in wings.

C. Flanks white or whitish.

D. White ring around neck, bill yellow.

*Male Mallard.*

DD. No white ring, bill blue.

E. Bill crossed by broad dark band, speculum grey, neck with brownish band.



*Male Ring-necked Duck.*

EE. Bill bluish.

F. Head greenish.

*Male Greater Scaup.*

FF. Head purplish.

*Male Lesser Scaup.*

CC. Flanks brownish like back.

D. White at base of bill.

E. Bill bluish crossed by dark band.

*Female Ring-necked Duck.*

EE. Bill bluish, without band.

F. Bird larger, wing over eight inches in length.

*Female Greater Scaup.*

FF. Bird smaller, wing less than eight inches in length.

*Female Lesser Scaup.*

DD. No white at base of bill.

*Female Mallard.*

BBB. White under wings, bird uniformly dark.

C. Bill yellowish, *Male Black Duck.*CC. Bill greenish, *Female Black Duck.*

AA. Birds with conspicuous light blue in wing.

B. Broad white band nearly encircling neck, bill broad.

*Male Shoveller.*

BB. White bar in front of eye, bill normal.

*Male Blue-winged Teal.*

BBB. Plumage uniformly brownish, except for wing marks.

C. Bill broad. *Female Shoveller.*CC. Bill normal. *Female Blue-winged Teal.*

AAA. No conspicuous marks in wings but not uniformly dark.

B. Tail long and pointed.

C. White of breast extending along sides of neck and behind cheeks. *Male Pintail.*CC. No white on neck. *Female Pintail.*

BB. Tail normal.

C. Wings and back grey.

D. Head reddish. *Male Redhead.*DD. Head brownish. *Female Redhead.*

DDD. Head and neck cinnamon, profile sloping.

*Female Canvasback.*

CC. Wings and back brownish, speculum green.

D. Head chestnut with green stripes.

*Male Green-winged Teal.*

DD. Head like back. *Female and immature male.*

*Green-winged Teal.*

AAAA. Birds with uniformly dark wings.

1. Head largely white tail pointed, white areas on body in some plumages. *Old Squaw.*

2. Head greenish with white stripes. *Male Wood Duck.*

3. Head brownish with white area about eye. *Female Wood Duck.*

4. Plumage entirely black.

C. Base of bill yellow. *Male American Scoter.*

CC. Plumage black except for white spots on head.

*Male Surf Scoter.*

5. Plumage reddish-brown, cheeks white, tail stiff and erectile.

*Male Ruddy Duck*

6. Plumage greyish-brown, cheeks light, tail stiff and erectile.

*Female Ruddy Duck*

April 19. 8 a. m. (1852)—Down river to half mile below Carlisle Bridge, the river being high, yet not high for the spring.

Saw and heard the white bellied swallows this morning for the first time. Took boat at Stedman Bittrick's, a gunners boat, smelling of muskrats and provided with slats for bushing the boat. Having got into the Great Meadows, after grounding once or twice on low spits of grass ground, we begin to see ducks which we have scared, flying low over the water, always with a striking parallelism in the direction of their flight. They fly like regulars. They are like rolling-pins with wings. \* \* \* Ducks are most commonly seen flying by twos or threes.

*Thoreau's Journal.*

## Hummingbirds

LOUIS AGASSIZ FUERTES

Ithaca, New York

Once when I was a little boy, playing in an orchard, I was suddenly startled by a loud velvety buzzing sound that came in "waves," accompanied by a faint but angry chipping. It made me feel very queer and spine-chilly, because I could see nothing, yet the sound was quite near. Finally though I saw the cause of

the strange noise,—a worried little hummingbird was swinging back and forth on buzzing wings like an angry little pendulum, and shrilly squeaking at me to go away.

By one of those rare chances just then my eye fell upon a little greenish lump on a drooping branch of the apple tree, and guessing what the fuss was all about I drew the branch down until I could see. Sure enough, it *was* the hummingbird's nest, a tiny cup of dandelion down and fern "felt", covered with cobweb and



Nest of the Ruby-Throat  
Hummingbird  
Covered with lichens

green scale-moss, only an inch and a half across and just big enough inside to hold two tiny rather long, white eggs.

Since then I have had many chances to watch hummingbirds all the way from Alaska to South America, and I have always been thrilled by their tiny size and great courage as much as by their indescribable beauty.

East of the Mississippi there is only one kind, the ruby-throated. From Texas to California there are about half a dozen, and the little rufous hummingbird goes all the way up to Alaska.

The male ruby-throat has the whole throat covered with polished scale-like feathers of a most lustrous and intense ruby-red which in different angles of light changes from orange to nearly purple. It is hard to imagine so tiny a creature—really little larger than a good sized insect—spending his summer in our eastern states and Canada, flying in the fall all the way to Central America where it

passes the winter. Yet it is true and the hummingbird has a much longer migration than most of our common birds, and its winter companions instead of being the squirrels, chick-a-dees, and warblers we know are parrots, tanagers, howling monkeys and jaguars.

In North, Central and South America there are over five hundred different kinds of hummingbirds, and there are none in any other part of the world. Only the Sunbirds of Africa and the Birds of Paradise compare with them in the glory of their colors. Yet to show these colors hummingbirds must be seen in only a certain way for their glow "goes out" like a light turned off when the bird changes from one angle of light to another.

In the brilliant forests of South America or high in the Andes above the growth of trees, a dark dull moth-like little thing, bobbing from flower to flower or shrub to shrub will suddenly catch the right light and burst into gorgeous green, yellow, red, blue or purple flame for an instant, only to "go out" again with the next dash or poise. Most of their brilliant colors are on the head, throat and breast but many have enormously long tails of fiery red, green, or blue, and all but one must be seen from in front to show their brilliancy. There is one, however, all rust-red except for the back between the wings and tail, where the feathers are intensely glittering, light green above, passing through pink to gleaming lilac. I have often wondered why this one kind should go against the rule of all the others, and show his brightness only from behind! But he does.

Many questions come up when we think about these lovely little things: why did only two kinds out of over five hundred get into the way of migrating—leaving the warm tropics and flying far, far north to build their nests and raise their babies? How, indeed, did these two kinds get started in their habit?

The biggest hummingbird of all is a dull, rusty brown bird as big as a chimney swift. The smallest is an inch long without the bill—about the size of a bumble-bee. Indeed, his Latin name is *Bombus*, which means bumble-bee.

Hummers are brave little mites, as the one I told of at first has shown. They do not hesitate to angrily attack a crow or hawk, and usually drive them quickly away when they come near their nests. Many kinds are especially beautifully fitted for their particular lives. One kind has a bill four inches long, for feeding in deep trumpet flowers; others have short needle-sharp bills to

pierce through the flower into the honey-cups they cannot reach otherwise, or curved bills to slip into queer tropical flowers that a straight one could not enter. They live both on the nectar of flowers and on small insects.



Their feet are tiny and delicate, but strong, for they perch a good deal. The variety of special decoration that the different ones have is almost beyond belief, and a mounted collection of rare hummingbirds is sure to be the chief attraction in any museum of Natural History. Some have great forked and glittering tails, others fancy crowns of different colors, or gleaming bibs of red, gold, green or purple; still others have wide ruffs or frills dotted

with emeralds or rubies, which stand out on each side of the throat like a broad cravat. Many have beautiful little "swansdown" frills about each foot—dainty little snowy pantallettes, while others are all glittering golden green everywhere.

Then there are many which live in the dark, damp, dripping forests of the lowlands, where insects eat one's belongings and mildew soon ruins everything. These are without bright color of any kind, dull, smoky, little sprites, sharing the somber dismal air with the army-ants and mosquitos and whose heavy, humming merges with that of the stinging, devouring insect pests that make these places dangerous and terrible for men to stay.

---

"The slender hummingbird whose molten-tinted wing but spoke the song of fluttering joy, and in thy very hand turned to motley gray."—PATIENCE WORTH.

### A Prize for the Best Arbor Day Essay

Mrs. Britton very kindly offers a copy of Alice Lounsberry's *Wild Flowers For Young People* as a prize for the best essay on the topics included in the schedule for Arbor Day compositions as given in the April number of the NATURE-STUDY REVIEW.

## The Bluebird

W. P. ALEXANDER

One bird I know, that haunts the blissful scene  
Where idling Spring renews her lavish wiles,  
And stores her gold, and countless tints of green  
To come with emerald step, and gracious smiles  
Some glad fresh morn:—but ah! my bird before  
Her train, with full, and strong impatient wing,  
Will bear the tidings to my very door,  
And I shall hear, deep stirred with wondering!

My bird has caught the gentian-hue of skies  
That over-arched those orient isles he found;  
Has cloaked himself in such becoming guise,  
And touched his breast to musk rose teeming ground;  
He learned the low, sweet cadence of the wind  
That touched with unseen lip the golden reed,  
And in his warble audibly entwined  
The lingering lilt, of zephyrs on the mead.

When March is harsh, and blustering bends the bough  
Of leafless tree, with young buds still asleep,  
All unawares, some morning, and somehow,  
I know again my sluggish blood will leap.  
When on my ear the old familiar strain  
Will fall, and I shall catch a flash of blue  
And know the gates of Paradise again  
Have open swung, and let my bluebird through.

For after him will come the myriad throng  
Of varied joys, that lead to perfect June,  
The upland glades, and vales a-ring with song  
And meadows with a mantling bloom bestrewn,  
But oh! the gentle warble, first to steal  
Into our ear, gives joy no other brings  
For winter-weary every heart must feel  
A benediction, when the bluebird sings!



Family of Wilson's Thrushes Showing Cowbird in the Middle

## The Thrush Family

GILBERT H. TRAFTON

Professor of Nature-Study, State Normal School, Mankato, Minn.

Photographs by the Author

Nine thrushes are found in the Eastern United States: the hermit, wood, Wilson's, willow, olive-backed, gray-cheeked, and Bicknell's thrushes, and the robin and bluebird. The species may be distinguished as follows: the wood, hermit, Wilson's, and willow thrushes are bright brown above, while the olive-backed, gray-cheeked, and Bicknell's thrushes are olive above. The wood thrush is brightest on the head, the hermit is brightest on the tail, while the Wilson's thrush is of uniform color above. The olive-backed and gray-cheeked thrushes are very similar, but the former may be distinguished by its buff cheeks and eye ring. Bicknell's thrush is similar to the gray-cheeked thrush but smaller. The willow thrush is similar to Wilson's thrush but slightly darker above.

The characteristics of the thrush family in which all agree are given by Chapman as follows:

"Length over 5.50; bill moderate, the tip of the upper mandible notched; tarsus smooth, the scales, if any, fused and indistinct;

tail square; wings long and pointed, 3.75 or over, third primary the longest, the first very short, less than one inch in length."

*Range.*—The bluebird breeds thruout eastern United States and northward into Canada; the robin breeds from the central states northward into Canada. The wood thrush breeds in the southern and eastern states up to the northern tier of states. The Wilson's, hermit, olive-backed, and Bicknell's thrushes breed in the northern states and in Canada. The gray-cheeked thrush breeds in northern Canada. The willow thrush is found in western North America, coming eastward in migration to Indiana and Illinois, and is found nesting in Minnesota.

*Nesting Habits.*—The thrushes show a great variation in their nesting habits. The robin, bluebird, and wood thrush have adapted themselves to man's presence and nest near human habitations. The bluebird nests in cavities and frequently occupies nesting boxes provided for it, while the robin sometimes occupies the open type of nesting box.

The hermit and Wilson's thrushes nest on or near the ground; the gray-cheeked and olive-backed thrushes nest in low trees or bushes; the wood thrush generally places its nest in small trees about 8 or 10 feet up; the robin locates its nest in a great variety of situations, but chiefly in trees from 5 to 25 feet up.

The robin and wood thrush use mud in the construction of their nest. The eggs of all the thrushes are bluish. The bluebird and robin generally rear two broods, while the other thrushes rear only one brood.

*Songs.*—The first place among bird songsters is quite universally given to the thrushes. There is a ringing, resonant quality about their notes that makes them the most pleasing sounds in nature. Some students give first place to the wood thrush, while others give it to the hermit thrush. The song of the wood thrush is more widely known and appreciated because it nests near human habitations and so is more often heard. One man records that he has heard over 70 different songs of the wood thrush. It usually sings near the sunset hour as well as in the morning. As the season progresses the wood thrush continues to sing after most of the other birds have closed their song season, thus making it one of the conspicuous bird notes during the early summer.

*Economic Status.*—The thrushes are a valuable insectivorous



group destroying many insect pests. Insects comprise more than half of their food, the remainder being composed chiefly of wild fruit. The robin does some harm to cultivated fruit, but this is more than balanced by the injurious insects eaten. The thrushes all eat a few beneficial insects, but this is small when compared with the injurious insects eaten.

The following table gives a brief summary of the food habits of some of the thrushes as determined by the studies made by the Bureau of Biological Survey:

(*Figures indicate per cent. of food*)

	Insect Pests.	Beneficial Insects.	Cultivated Fruit.
Bluebird .....	47	9	
Robin .....	33	6	8
Gray-cheeked Thrush .....	55	3	
Hermit Thrush .....	40	3	1
Olive-backed Thrush .....	47	3	(12)*
Wilson's Thrush .....	41	1	(12)*
Wood Thrush .....	38	2	4

\*(Practically no harm is done by the olive-backed and Wilson's thrushes in eating cultivated fruit, because most of it is either waste fruit or is taken from wild plants.)

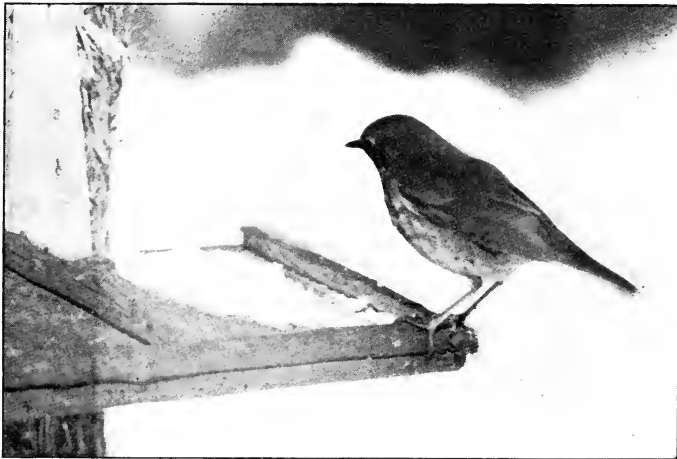

A Hermit Thrush at the Lunch Counter



Tree Swallows

## Our Most Intimate Bird Neighbors

LAURA A. L. TURNER

Buffalo, N. Y.

All through the cold bleak winter days the writer had been telling school children, inexperienced teachers and Mothers' Clubs, just how to have fine neighbors. With the coming of the migrant birds, the chance remark of an incredulous listener, sounded like a challenge to prove the value of suggestions made to others. As a result, this accurate account is given of how five species of birds come to nest in a 45 x 150 foot lot in a closely settled residence section of the city of Buffalo, N. Y.

The house, framed by shrubbery, stood thirty feet back from the street. The grass plot and garden at the rear was surrounded by a strong board fence bordered by shrubs and young trees. A bird bath, made in the top of a 12-inch sewer tile was an important feature. This bath was cleaned each morning and filled with fresh water.

Three species of birds had nested on the lot the previous year. Late in April a pair of robins were observed to be prospecting. A dish of thick mud was at once made ready and various strings, rags and long rootlets, were left carelessly about the lawn. These helps appealed at once to "Betsy" Robin and in building her nest on a bracket under the eaves, on the south side of the house, she freely made use of the available material. Four young robins flew out from this nest and got safely on the wing.

On the warm bright morning of April 25, the Tree Swallows, "Top" and "Topsy" arrived and went at once to the box, 20 feet up, on the rear of the house which had been their home the previous season. No one who watched the familiarity of these birds with their surroundings could doubt but that they were the same birds, which had nested here before. Their joy in homecoming was unmistakable. However, they soon discovered a new box of the

same proportions as those of their former home, (5 x 6 x 11 inches) but with an eastern exposure on a telephone pole at the rear of the lot. A week of indecision followed and material was carried into each house—but they finally decided on the new location. Two families were reared and ten young swallows came out from this box. These beautiful birds with their delightful twittering warble and wonderful flight gave pleasure to the entire neighborhood.

On May 3, "Pat" and "Patsy" Yellow Warblers, came back to the lawn. Bunches of cotton were tied on the Forsythia branches and in two days a beautiful white nest was completed among the green leaves, in almost the same spot as the nest of the previous year. This made a fine setting for dear little yellow "Patsy." The nest was about 15 inches from the window of the living room, on a level with the sash, and was viewed many times a day by the family and guests. Three baby warblers left this nest in safety and spent the summer days in the vicinity.

On May 5 the long hoped for wren arrived. He had a painful seige of indecision between four houses in the neighborhood suitable for a new home. In fact, bubbling with song, he carried material into each of the four boxes. After a week "Jenny Wren" appeared and she very quickly made decision in favor of a shabby little old box, on the back of the house, which was up for its fourth season, in faith that, sooner or later, it would have a tenant. The wrens once settled, there was scarcely a quiet daylight moment. Our appearance on the lawn or in the garden, sent "Jen" to the peach tree near the little home, where he poured out a variety of songs, which were a delight. If a cat came near, Jen gave the alarm note which he knew would bring assistance. When four baby wrens were on the peach tree and the English sparrows began to annoy the babies, "Jen" called loudly for help, and when it arrived, sat fearlessly by, while lumps of dirt flew past him in the direction of the sparrows. This wren family was visited by many admirers and their disappearance on August 15 caused universal regret.

On May 28 a pair of small birds came to the young elm tree in plain view from my desk window—a moment's watching of attitude suggested that horse hair would be needed right away, if these prospectives were held as tenants. The cover of a hair pillow was hastily ripped and bunches of hair tied to the trunk and branches of the elm. Mrs. Chipping Sparrow found the proffered material

at once and constructed a nest, well up in the young tree, that looked very comfortable. If these birds had invited me to select the site for their nest, I could not have placed it to better advantage for observation of all the little family "spats" and "making-up" peculiar to the little "hair birds." "Chip" was frequently met about the rosebushes, where he paid rent by eating aphides, while "Chippy" incubated the eggs.

From dawn till noon sweet bird music filled the air. Opportunities to study bird characteristics were more abundant than time in which to do the studying. All of the birds perched on telephone wires, but each species had its own precinct. Wires are a valuable asset in bird attraction.

Time, thought and eternal vigilance for more than three months, resulted in constant enjoyment of an intimate acquaintance with my bird guests and a happy memory that will not fade.

## The Nature Lover

GEORGE B. STAFF

He leaves the city scenes behind,  
 Forsakes the binding office walls,  
 And goes where Mother Nature kind  
 Is waiting, where the low wind calls  
 Through leafy branches, cool and dim,  
 That spread a welcome shade for him.

And as with seeing eyes he wends  
 His way through forest solitude,  
 There comes a knowledge that transcends  
 All creeds and science, where his mood  
 Is one with Nature, and the Power  
 That grants the peaceful twilight hour!

## House Wren

With head up and tail up,  
 The wren begins to sing.  
 He fills the air with melody,  
 And makes the welkin ring.

## Bird Notes



—Photo by C. W. Leister

### THE CHESTNUT-SIDED WARBLER

C. W. LEISTER, Ithaca, N. Y.

The nest was found on June 17th on a bushy hillside about three miles from the city. The situation is quite a desolate one, covered with a tangle of briars and slash from old lumbering operations. The nest was in a patch of raspberry vines and was about three feet from the ground. It was rather loosely constructed of interwoven grasses, lined with shreds of grass and fine rootlets.

The eggs had already hatched, and the ever hungry young kept the parents busy carrying food. The mother-bird did most of the feeding while the father furnished music, from a nearby sapling. He occasionally helped in the work, however, and sometimes both would be at the nest at the same time.

The food brought to the young consisted of caterpillars, chiefly cutworms and leafrollers. An occasional spider was also eaten.

The nest was in such an isolated locality that it was not visited again.

## SOME ROBIN ANNALS

GEORGIA SWEETLAND, Ithaca, N. Y.

An old apple tree in our back yard, which has housed many generations of robins, has furnished a fine opportunity to observe the individual traits of these birds. I saw in early Spring two birds flitting about in the apple tree, and watched them for a time. The male robin was hopping about a promising looking site, made by the separating of three branches. He turned his head on one side and then on the other in the knowing way robins have, and called to the lady to look, then sat down flat on the place and fitted himself to it and nestled around as they do when placing materials in the nest, as if to show her how fine a place it was. She assumed an air of indifference and continued investigating on her own responsibility. Again he would fly to the place of his choice and measure it and call to Mrs. Robin, but she paid no attention, and later chose a place in our neighbor's pear tree, way up on the tip of a limb, an entirely different sort of place from the one selected by him.

\* \* \*

One male tenant of the apple tree seemed to think his judgment of building material was superior to his lady's, and he industriously flew about getting suitable material for building, according to his way of thinking; but as soon as she saw him with anything in his mouth she would fly at him and he would obediently drop it. This sort of thing went on for several days. I really felt sorry for the disappointment of the bird. He would slyly take up pieces of twig and weight them in his bill and look towards the nest, but invariably he was apprehended and in no gentle way made to understand that his services were not then required. But one rainy day, when the nest was near completion, I saw her sitting on a limb high up, and seeming to direct the labors of the father as he, down on the ground, was gathering mud. When he had a suitable load, they both flew to the nest and he kept this up till he had carried the amount of mud required by his exacting mate, and a woe-begone looking bird he was before its finish.

\* \* \*

A neighbor of ours rescued a young robin from a cat and brought him to me. His wing was badly torn and only one tail feather was left. I put him in a cage on the back porch and he soon became tame and seemed to enjoy his house. I sometimes took him out

to let him fly about to strengthen his wing, but he would soon return to his cage. He was named Goliath.

Another young robin was given me whose mother had been caught by a cat. I put him in the cage with Goliath but Goliath's opinions and mine were evidently not in accord on that subject, for he fought the robin guest so persistently the younger bird had to be removed. Having exhausted the supply of cages, he was given a basket in a room in the house. He took to the basket immediately, and also became quite gentle. He was named Samson. He grew quite fond of me, and when not confined in his basket, would fly through the house after me and ride around on my head or shoulder or hand as happened to be most convenient to him. Samson soon came to regard the entire house as his property, and when I brought Goliath in for his daily exercise, Samson would immediately attack him, and although Goliath was older and larger, he seemed to recognize Samson's right to the house and was as meek as possible. He was even afraid to eat when inside unless I put the food in his ever open bill. It was very funny, as soon as Goliath came in, to see Samson jump on his back and pull his one tail feather. But if I tried to put Samson in the cage, the situation was reversed, and Goliath would fiercely attack the now meek and trembling Samson, these traits evidently indicating a respect for the property rights of others.

They regarded me as their mother and would give their food call as soon as they heard me. Samson had a way of hiding some times in the room, and I often would not see him, but when called, he always answered with a chirp.

In the fall, before migration time, much to my regret, they were taken out in the open and set free.

#### A BOY'S ACCOUNT OF HIS TAME CROW, JACK

ROBERT PARSONS, Ashtabula, N. Y.

In the summer of 1915 Carter Ellis was coming through a woods, south of Erie and found a young crow that was just learning how to fly. He caught it and put it into a bag that he had with him. He took it home and it would not eat at first but soon it learned to take milk out of a spoon and it would go around picking up things to eat.

After Carter had the crow for about three weeks he gave it to Henry Thomas who lived near me, and his father got tired of

having the crow around so Hank sold it to me for the sum of twenty-five cents in August, 1915.

I named him Jack, and he will steal anything bright and will hide it under leaves or anything that he can lift with his bill. He tipped the milk bottle over once and was in the act of tearing up the tickets when a neighbor called and told me what he was up to. Some carpenters were working next door and the crow went over there and brought some nails home after he had dragged some tools away.

After I had had him about a month a woman told me that if I slit his tongue he would learn to talk and a neighbor said that he knew how and so I let him do the job. He forced the crow's tongue out with his finger and held the crow against his knee and then with a very sharp knife he slit the tongue a little down the middle, about three-sixteenths inches. He said that if he had cut any farther he would cut a blood vein and the crow would bleed to death.

The next day I repeated "hello" over and over to it and in a couple of days I heard him trying to say it and now he can say "hello" and "hey Bob" as plain as any one.

In April, 1916, we moved to the country and Jack went to killing young chickens. He killed seven that we know of and I have caught him at eating eggs. He spoiled some water melons by pecking at them and one day my mother put two pounds of pork on the back window sill outside and when she come to get dinner she beheld Mr. Jack hauling it around the yard.

His feathers had grown out so that he could fly and he took to flying away and one day he flew from one telephone pole to the next, following my brothers to school. He stood on the fire escape all day yelling "hello" with all his might. My brother caught him after school and carried him home. I cut the feathers from one wing that night because I did not want him to be bothering the children at school.

With all his bad qualities, he makes a good pet anyway so I think that I will never get rid of him.

On warm days he takes a bath about six times in a pan of water that is meant for the chickens' water dish. The chickens and the crow are not very good friends and the older chickens chase the crow around and the crow fights with the younger ones.



## WHAT TO DO WHEN STUDYING BIRDS

ORA SWEET, Auburn, N. Y.

1. Dress inconspicuously. Birds have keen eyesight.
2. Keep quiet. Birds have very acute hearing.
  - (a) Avoid conversation.
  - (b) Step noiselessly.
3. Look and listen.
4. Do not point and exclaim when a bird is sighted.
5. Never chase birds. Have patience. Stand still a great deal and use your common sense all the time.
6. Keep the sun at your back.
7. Use field or opera glasses.
8. Keep a note book.
  - (a) Write your observations on the spot.
  - (b) Absolute accuracy is essential in bird observation.
  - (c) Look first for the general color, then for the colors of back, breast, wings and tail.

## PURPLE MARTINS AND THE BOLL WEEVIL

ELIZABETH M. NORTON, Savannah, Ga.

While I was in Macon, Ga., in October of 1916, my hostess, Mrs. Codington, told me of the very interesting experiment which is being carried on at her father's plantation. Her father is Col. Foot of Mt. Airy, Ga., but he owns a big plantation near Albany. A few years ago he noticed a few purple martins on his land, and put up houses for them. The martins came in increasing numbers, and he continued to provide shelter for them, till now he has between seven and eight hundred of them on his plantation. Meanwhile the boll-weevil had invaded Georgia and the planters on all sides of Col. Foot were almost ruined by them. He has had no trouble at all with the boll weevil, and attributes his being exempt from the universal pest to the presence of the purple martins on his land. Mrs. Codington also said that he had written to the government about it, and that the government was keeping an expert down on her father's place to observe the birds, etc., and see whether the ultimate solution of the boll weevil problem of the South lay in providing protection for the purple martins. I remember that she told me of one bird which they had cut open for experimental purposes, finding in its stomach an immense number of insects, weevils, etc.

## RULES FOR BIRD HOUSE CONTEST FOR 1917

Y. M. C. A. of Erie, Pa.

This contest shall be for any boy under 20 years of age in the City of Erie.

Each boy is put on his honor to do all work on the house himself.

Houses to be built to conform with dimensions given in Farmers' Bulletin on Bird House Construction.

These dimensions may be secured from manual training teachers in Public Schools or from the Boys' Work Secretary at Y. M. C. A.

First, second and third prizes will be given for the three best houses in each class.

Houses for following birds are to be built: Bluebird, Robin, House Wren, Martin, Flicker, Red Headed Woodpecker or Hairy Woodpecker, Downy Woodpecker and Food Shelter.

Contest to close April 9th.

Get a card from your principal or at the Y. M. C. A., and enroll in the contest now.

Send all entries into Y. M. C. A. immediately.

Competent judges will judge the houses.

There will be an opportunity given to sell houses at close of contest.

*Please enroll me as a contestant in the Bird House Campaign, to end April 9th, 1917.*

I will make a house for ..... (Name of Bird.)

Signed.....

## A VISIT TO BIRD ISLAND

L. B. CUSHMAN, St. Petersburg, Florida

A bird enthusiast spending the winter at St. Petersburg writes of a visit to Bird Island, a Government Preserve, where no one is allowed to land, but where "I saw hundreds of Pelicans, many of which had located on top of mangrove bushes for the night, while numerous big Ward's herons came and alighted on top of the higher trees. I saw an abundance of cormorants, what was said to be an ibis, and a white heron. I contemplate going again, soon, before daylight or at dusk, so as to see the birds come in or go out and see them roost. There are water ways among the trees, so we can slip right in among them in a row boat.

I see the great star Canopus here every night."

## BIRD FOUNTAINS IN THE GARDEN

MATHILDE SCHLEGEL, East Aurora, N. Y.

Marble fountains are beautiful and cement basins enhance a garden, but our bird-neighbors drink from and bathe in a ten-inch



Photo by M. Schlegel

flower pot saucer quite as happily if it has the proper setting of a woody background, from whose shelter they can flit out into the sunshine, take a drink and splash in the cool water, yet loving the warmth of the sunshine, and then retire into the shady retreats of the shrubbery to dress their plumage and sing their happiness that during the summer's drought there is this un failing source of water for their joy and benefit.

It has been undoubtedly this source of supply which has attracted and induced the pair of catbirds to nest in the garden and every spring and fall the white-throats come and the shy hermit thrush lingers for awhile during his leisurely journey either way, but always he is silent, tho I have listened longingly for his utterance. If the white-throated sparrow will whistle from the hedge and the white-crowned sparrow and the ruby crowned kinglet will sing as they pause on their northward flight why does the hermit deny us the delight of hearing his wonderful melody? Surely it would tone in the garden depths, and be a never forgotten episode.

## A WILLY-NILLY STEPMOTHER AND OTHER DISASTERS

ALFRED EMERSON

Nature-Study Teacher in Campus School, Ithaca, N. Y.

The tragedies of the bird world were brought home to me last spring while observing the raising of twelve different families immediately surrounding my house. These nests included three robins', two cedar waxwing's, a chickadee's, a yellow warbler's, a catbird's, a bluebird's, a red-eyed vireo's, a meadowlark's, and a chipping sparrow's. All these but four raised their families to maturity. One pair of robins, one pair of cedar waxwings, the chickadees, and the catbirds brought their young through, but the rest perished in one way or another. The red-eyed vireo raised a fat cowbird instead of its own babies; man was responsible for the loss of the meadowlark's nest, and the rest, with the exception of the chipping sparrow's, were destroyed by cats.

In the case of the chipping sparrows I observed a remarkable occurrence which I had never observed before nor have known of any similar case. The chippy's nest was situated in a small elm tree about seven feet from the ground. I first found the nest after four eggs were already deposited. The little parents seemed quite happy and contented, and the male especially could be heard chipping away in a nearby tree for most of the day. The female was usually found on the nest and did not mind our approach to observing distance in the least. The chippies seem to have confidence in man, more so than any other sparrows and these in particular, trusted me completely.

One day after the eggs had hatched, I found much to my surprise that a robin had driven the distracted parents from the nest and was attempting to sit on the young, although she did not nestle very close. I, of course, having sympathy for the chippies, drove the robin off and let the rightful parents come back, but as soon as I was safe in distance away the robin returned. Our whole house became interested in the affair and each of us would drive the robin off whenever we passed, but to little avail. The true parents were very anxious to keep the hungry mouths filled, but the robin would still sit on the nest while the forlorn chippies would hop within a few inches of the nest with large amounts of food for the gaping mouths. They would remain very close to the nest fearlessly while we chased the robin off, and then would come quickly to feed the

young. The robin did not seem to realize the babies needed food for quite a few days, and to my knowledge fed them only once.

Of course this state of affairs could not last long and in six days from the advent of the robin I noticed the nest was deserted. When I climbed up to see what was in the nest I found the four babies dead.

The only cause we could guess for the adoption of the nest by the robin was that her own nest had been destroyed in some way and her maternal instincts were so strong she had to adopt another family. The chippies of course were so small that they could offer no resistance while one of her own species would certainly have fought her.

A pair of birds that I forgot to mention raised four healthy broods in an old telegraph pole near us. Each brood had at least four young and no trouble was found that hampered them in their development. This species was, of course, the English Sparrow.

#### THE NEST OF THE BLACK-THROATED BLUE WARBLER

DOROTHY K. CLEAVELAND, Canton, N. Y.

July 13th was anything but an unlucky day for me—for on that day I had one of my rarest bird treats. We were taking a tramp through the upper Reservation of the Appalachian Club at North Woodstock, New Hampshire. The fall before, a new trail had been cut through the back part of the Reservation where the ground is rather swampy; it was merely blazed and in some places hard to keep.

I was leading, breaking my way through an undergrowth of young basswood, when suddenly from right in front of me, not three feet away shot out a little mother-bird, crying and pretending to be hurt and in great distress. I knew her nest must be near, so I stepped forward and looked and there in the crotch of a young basswood was a little nest with four naked, blind birdlings in it. Two big leaves sheltered it from sun, wind and prying eyes.

The next thing, of course, was to identify the mother. She was still near us, crying and fluttering around—too frightened for her babies to go far away when we refused to follow her. I took her points, especially the white spot on the wing at the base of the primaries, which satisfied me that I had found the home and family of the beautiful Black-throated Blue Warbler—though his wife had

neither black nor blue on her but only a neutral olive green with whitish underneath.

A PARENT TEACHER'S ASSOCIATION INTERESTED IN BIRDS

MARGARET F. SMALL, Springfield, Mo.



Chrissie Reeves and the Bluebird's Nest she Made from an Abandoned Woodpecker Apartment.

I am enclosing the picture of a bird-house which was one of the five hundred made by the school children of this city, the work being done chiefly at home, in a contest given under the auspices of the Council of Parent-Teachers Associations.

This particular house was made from the limb of a cherry tree where a woodpecker had built its nest the year before. The inside of the nest was plastered with what seemed like wood pulp and sand made into a solid mass.

Can any one explain this phenomenon?

STATIONARY BIRD HOUSES INJURE TREES

PARMALEE EVANS, Erie, Pa.

"Never allow stationary bird-houses in any of your trees!" Many times this statement, from a city forester, is received with surprise by bird-house enthusiasts.

By a "stationary" bird-house, we mean one that is nailed or wired firmly and permanently. It hinders the growing bark and, if the pressure is unresisting, usually kills it. If a piece of lumber (whether a part of a bird-house or not) is nailed to a tree, it will

keep the bark underneath, damp and unhealthy and insects will find space for egg masses to hatch unmolested.

Instead of nailing the house to the tree, a better method is to make two holes just below the roof in the back of the house as far apart as possible, so that the house may rest solidly on two corresponding nails or hooks driven into the tree. Now, the bark is free to expand in growth, while if the board were nailed tightly, the bark underneath by the beginning of the second summer would show signs of decay. By this method we have the advantage of a periodical removal of the house and examination of the bark.

#### A LIST OF BIRDS THAT EASTERNERS WOULD LIKE TO SEE

The editor is the recipient of the following record from Miss Barbara Marx, eleven years old, and a member of this bird class:

"I am enclosing the list of birds we have observed. "We" means the fifth and sixth grades of the Castilleja School of Palo Alto, California. The other morning Miss Hayes, our teacher, divided us into groups so that we wouldn't frighten the birds away, and it was then we saw the owl, cedar waxwing and woodpecker. The only peculiarity we have found worthy of note is that the towhee scratches with both feet at once.

White Crowned Sparrow, Gold Crowned Sparrow, Oregon Robin, California Robin, California Towhee, Willow Goldfinch, Bush-tit, California Jay, Crested Jay, Anna Hummingbird, Ruby-throated Hummingbird, Bluebird, Woodpecker, Barn Owl, Cedar Waxwing."

#### FEEDING-TABLE NOTES

##### THE EDITOR

One lone but by no means lorn red-breasted nuthatch has been a daily visitant to the feeding table all winter. When he first came he was very shy and very poor and needy in appearance; he had no spunk and a chickadee could drive him away by simply appearing within his range of vision. But as he partook of the suet and sunflower seeds he grew fat and his courage waxed with his plumpness. He finally tried to boss the whole company and would drop down in a lordly manner in front of a white-breasted cousin twice his size, to make him beat a hasty retreat. He had many admirers among the nature-study classes; his ways were delightful and his appearance fascinating even to the cuteness of the cut of his bob-tailed coat. A New England lad was heard to apostrophize him thus: "Oh, you pretty, sassy little bugger."



## The Bird Work in the Ethical Culture School of New York City

MYRTLE BASCOM BOICE  
Teacher in Nature-Study

Bird Study in the Ethical Culture School is a very important part of the nature-study work. Excursions to Central Park give the pupils opportunity to observe the common winter and summer residents, as well as the migrants. In the class room the study is made more effective by the use of colored pictures, stuffed specimens, and slides, the latter loaned by the American Museum of Natural History from their splendid collection.

Classes are taken to the Museum, where the birds not found in the Park are studied in their natural habitats. Some of the children spend week-ends in the country during the fall and spring months, and do independent bird work. These observations are reported to the classes of which they are members.

In the primary grades the common birds are identified, the calls and songs learned, their food and nesting habits observed and discussed. This is made possible by visiting the bird feeding stations in the Park in the winter, and watching the migrant birds when they return in the spring. The chickadee, starling, and



English sparrow are winter studies; the robin, oriole, and the gull in the spring. Others are identified and observed, but we are careful not to confuse the little people with too much information.

Beginning with the fourth grade and including the seventh grades, the pupils are ready for more intensive bird study. A simple classification is made and some of the bird families are studied. Migration is made a most interesting subject for discussion. This year we have used Mr. Chapman's excellent book "Bird Travelers" with very good results. The economic value as well as the aesthetic is taken up with the children. In the manual training classes bird boxes are made by the second and fourth grade children.

This year March has been a Bird Month. The Women's Conference of the Ethical Culture Society prepared a splendid bird exhibit in their room in the Society building. This exhibit was made possible by contributions from the Museum of Natural History, the Bronx Zoological Garden, the Audubon Society of New York, the Department of Agriculture, the Ethical Culture School, and the publishers of the best bird books. In this exhibit were colored pictures of the birds of New York State arranged according to their families and food habits, their time of arrival in the spring, and the winter residents; a collection of bird houses, feeding devices, and baths, stuffed specimens of the common birds, nests, bird books, original books arranged by several children, and the literature given out by the Department in Washington.

This exhibit has been the means of interesting many mothers who will take up the study with their children during the summer. On the morning of April 20th, Mr. Louis Agassiz Fuertes of Ithaca, will give his bird lecture, illustrating with slides and bird songs.

---

## Spring in The Swamp

PHOEBE BIRD

Red-wing atilt on a cat-tail fluff  
 His challenge sings with glee:  
 "Look at my epaulets scarlet and buff!  
 See me, Beloved, see!  
 It is I and I love you quite enough,  
 It is I, and believe me I'm the stuff,  
 Listen now, for it is no bluff,  
 Heed me, see me, see!"

## Bird Protection

GUY A. BAILEY

Professor of Biology and Nature Study, State Normal School  
Geneseo, N. Y.

Considerable time is nowadays devoted to the manufacture of bird boxes both by the professional wood-worker and the manual training departments of our schools. Then we have many boys and girls who put up empty starch boxes and such other boxes as the grocery man may have to give away. Just which kind the birds prefer is rather difficult to answer for birds seem to use almost any kind if the location is suitable. In any event more time is put on the making of the box in many cases than on the selection of the location. With some the point seems to be to get the birds to nest near by where they may be easily observed. If a dozen kinds of birds could be brought to the front yard that would be highly desirable. In the case of many of our birds it would be better for them and their young if the nesting sites were farther removed from habitation for the reason that in the case of the chickadee, house wren and some woodpeckers the young frequently come to the ground where they are picked up by the prowling house cats; so that what is intended as a real benefit for the birds turns out to be a fine piece of work for the hungry cat. It would be well to consider the cat question before trying to get the birds too near the house. We should keep in mind that in the rural sections we have a cat to one hundred acres or more, while in the towns we may have one hundred cats to the acre. All these cats may roam through the same little patch of woods, park or ravine as the case may be. Is not the first consideration in bird protection the elimination of neglected cats?

What has been said about nesting boxes may apply to the question of feeding birds. We have a great many kinds of bird foods. Much time has been spent in finding out the best mixtures and there are many useful and ingenious feeding boxes on the market. Attracting birds, however, to a particular spot for any length of time is sure to bring the cats. By hiding in the neighboring hedges or brush piles or grass they have a far greater number of birds to choose from than would be the case if there were no feeding places nearby. The cats become clever in striking down birds in the vicinity of feeding boxes. A place where I have been feeding

birds for ten years has been the regular hunting ground for a half dozen cats. They are just as regular at their meals as are the birds. This feeding place has been discontinued because it was merely a handy place for hungry cats. Feeding birds in many cases is simply feeding cats. Feeding stations may be established far enough away from town so that the cat will not follow. There are ways of outwitting the cats in the case of some birds like woodpeckers, nuthatches and the like but care needs to be taken in the matter of the location of the feeding box.

After all, it seems rather unfair that a boy who shoots a song-bird is liable to arrest and fine and possible imprisonment while a person may keep, without a particle of responsibility, a dozen cats each of which catches a song bird every day for a year and the law provides no penalty. Of course we can not arrest the cat under the law but the cat that roams should not have a place in the law. It should be classed with sewer rats, weasels and other vermin.

New York state is considering the question of licensing cats in order that the worthless and homeless cats may be known and legally put out of the way. Some opposition has been offered by the humane societies on the ground that the wearing of a collar and a tag endangers the life of a cat when it is crawling around through brush and trees. It would seem that any cat that is hung is deserving of its fate for it is probably catching the birds that some child is feeding. Speaking of cruelty how about the cruel habit of the cat in playing with the birds it has maimed. There is more cruelty here than would be possible if a few cats were caught by the neck. It seems unfortunate that a law that would be so helpful to bird protection is opposed by some, not all, of the humane societies. If the law is delayed, just so much farther away is the day of abundant birds.



If a Cat is Worth Anything it is Worth the Cost of a License

# THE NATURE-STUDY REVIEW

DEVOTED PRIMARILY TO ALL SCIENTIFIC STUDIES OF NATURE IN  
ELEMENTARY SCHOOLS

Published monthly, except June, July and August. Subscription price, including membership in the American Nature Study Society, \$1.00 per year (nine issues). Canadian postage, 10 cents extra; foreign postage, 25 cents extra.

**Important** Please note date of expiration of your subscription on the label of the wrapper. Subscriptions must be paid in advance to comply with postal requirements. Subscriptions and advertisements should be sent to *The Comstock Publishing Co., Ithaca, N. Y.* Manuscripts for Publication and Books to be Reviewed should be sent to the Editor.

---

## Editorial

JOHN BURROUGHS

The third of April was John Burroughs' eightieth birthday. We thought that our little snowy trilliums, Christmas roses, snowdrops and yellow crocuses were brighter and that the song of our bluebirds was sweeter that day than ever before, for of course, they were celebrating the day. We had heard with sorrow of Mr. Burroughs' recent bereavement and had felt great concern over its effect upon him. It was with real gratitude that we read in the *New York Times* of April first, a reassuring interview with him at his home: "Mr. Burroughs came down from the woodshed where he had been chopping wood! Ruddy and hearty, erect and nimble, there is no sign of age about the man save the whiteness of his hair and beard and the wisdom of his eyes." And what a comfort to us all was his assertion to the reporter "I have done more literary work this year than in any year of my whole life. It came to me and I just wrote. I never overwork, or burn the midnight oil. I don't draw on the future. I chop wood and work in the garden and keep well. My interest in outdoor things and current things is just as fresh as it ever was."

For many years we have read what he has written with such utter satisfaction that we had never thought of reading anything about our best beloved naturalist; then, one day, we met him and discovered with a feeling of deep relief that he was just the kind of man to write John Burroughs' books; many authors are personally so alien to what they write that it is a calamity to the reader to meet them; but not so this author; his books are just like him. Still we only knew about him those things which the newspapers

tell us until last week, a kind fate brought to the Editorial bookshelf *Our Friend*,\* *John Burroughs*, by Dr. Clara Barrus, a delightful volume, every page of which leads to a more personal and intimate acquaintance with this man of sturdy and enriching personality. Vivid and graphic word pictures are given of his environment and activities, a fine setting for the heart of the book which consists of the chapters of autobiography written as informal letters to the author.

"Slabsides" has been a part of the public consciousness for years and it is interesting to read of the reasons for its establishment. The teeming social current that sweeps through every home in this day and generation, making life complex and burdensome also flooded "Riverby" the home which Mr. Burroughs built in 1874, and he sought retirement in a place where he could "read a little, write a little, and dream a good deal." First he built a "study" on a hillside near Riverby, but this was too near the current to be even a restful eddy; so he sought for a site for a hermitage near a mountain stream which Whitman had described as "a stream of hurrying amber, thirty feet wide, risen far back in the hills and woods, now rushing with volume—every hundred rods a fall." Here indeed was the ideal place, and Slabsides was built. But it was not long before Slabsides had set up a social current of its own; pilgrims, students, artists, authors and nature lovers from afar and near climbed the hill and invaded the hermitage that wouldn't somehow *hermit* its founder. The reason is not far to seek, for John Burroughs is essentially a social being, even though he esteems himself a poor mixer. His readers have always felt themselves an essential part of the triangle, the other two sides being Burroughs and Nature. They feel that he is writing to them. Here is where he departs widely from Thoreau who never wrote his nature notes to be read of men; he wrote his philosophy of life for men but he wrote of nature merely as self expression.

Perhaps because of the uphill current that beat against the bark-covered walls of Slabsides, Mr. Burroughs sought another retreat at the home of his youth where every view was in the truest sense learned by heart. Thus "Woodchuck Lodge" has come to be his home for part of the year, distracting the social current that surges ever toward him.

\*Published by Houghton Mifflin Co., 287 pp. Price \$2.00 plus postage.

Was there ever such an autobiography as is presented in these letters! So lucid, so honest, so graphic with all the little nooks and crannies illuminated as by sunlight flashed from a reflector! It is a wonderful record of life in a farm home in New York during the first half of last century. It is interesting to note that although as a boy, sugar making in "the sabbush in the groin of the hill" was the only part of farm work that appealed to him, yet he has always from choice been a farmer. His child life on the farm gave Mr. Burroughs his background as a naturalist; he writes "When I began in my twenty-fifth or twenty-sixth year, to write about birds, I found that I had only to unpack the memories of the farm boy within me to get at the main things about the common ones. I had unconsciously absorbed the knowledge that gave the life and warmth to my page." What a pity that the farm home of to-day is not preparing more naturalists in this natural way! The farm child of this age seems to us to be always facing the road made smooth for the whirring wheels of "the Ford", and has turned his back to the woods and fields, but maybe this is undue pessimism.

#### CHEERFULNESS AND EFFICIENCY

Is it true that efficient people are always cheerful? This opinion has been forced upon us many times; but the converse is not necessarily true, for the happy-go-lucky person is usually far from efficient. However, to be able to do things well is in itself a cause for gratification which stimulates a cheerful attitude toward the world. These reflections were stirred in the editorial mind through watching the chickadee open sunflower seeds at the feeding table. The chickadee is cheerfulness epitomized and vitalized, and perhaps he has gained this quality because he is always able to cope with his own special problems. He pounces down upon the feeding board, selects his sunflower seed with celerity and the skill of a connoisseur, takes it over to the rim of the feeding table and holding it flat side against the side of the rim with his two feet, he lifts his head high to gain force, and drives blow after blow into the tough shell until it is pierced and broken; he still holds the seed by the ends with his capable toes while he extracts the meat. The whole proceeding is characterized by alertness, self-confidence and skill, which certainly combines to form chickadee efficiency; and what a glorious cheerfulness it is, thus founded on conscious power of achievement!

# The Teacher's Corner

THE EDITOR

The following outline for studying a bird is the one I have used for years and have found it fairly satisfactory:

Date.....

Name of bird.....

1. Where is the bird seen: Woods, border of woods, bushes, open field, trees or bushes along fences, roadsides, border of stream, marsh, pond or lake, garden, orchard, about buildings.

2. Compare the size of the bird with that of the crow, the robin, or the English sparrow.

3. Its most striking colors are: Gray, slate, brown, chestnut, black, white, blue, red, yellow, orange, green, olive.

4. Does it show flash colors when flying? If so, where and what color? Wing, rump, tail, under tail.

5. In action is it: Slow and quiet or active and nervous?

6. Does it occur alone or in a flock?

7. In flying does it go: Straight and swift, dart about, up and down, wave-like, flap the wings constantly, sail or soar with wings steady, flap the wings and then sail?

8. Describe its song and call note?

9. Where does it sit when singing? Does it sing while flying?

## FOR CLOSER OBSERVATION

10. Colors and markings of: Breast, throat, wings, tail, top of head, eye-streak, back.

11. Is the bill: Slender, long, short, strong, thick, medium, curved, hooked?

12. Is the tail: Forked, notched, square, rounded?

The following questions should be answered from observation, if possible; if not, the answer may be found by consulting bird books:

13. What is the food of the bird and how obtained?

14. Where does the bird spend the winter?

15. Describe the nest, where placed, how far from the ground, how supported, of what material is the outside made, how lined? The color and number of eggs.

16. How are the young fed and cared for? The colors of plumage of the young birds.

17. Is this bird beneficial to us, and if so, how and why?

---

"In the early years we are not to teach Nature-Study as science, we are not to teach it primarily for method or for drill. We are to teach it for living and for loving—and this is Nature-Study. On these points I make no compromise.—L. H. BAILEY.

## News Notes

The several state universities, colleges and normal schools of the Pacific northwest are planning their summer sessions this year with special reference to the needs of visiting teachers who wish to attend the annual convention of the National Education Association, to be held in Portland, Oregon, July 7-14. Convention week will constitute a vacation period for the summer schools, dividing the session into halves, thus making it possible for teachers to get the full benefit of the convention without sacrificing their summer courses. The following schools offer summer sessions: State University, Eugene, Ore.; Oregon Agricultural College, Corvallis, Ore.; University of Washington, Seattle, Wash.; Normal School at Cheney, Wash.; State Normal, Bellingham, Wash.; Ellensburg State Normal; The State Normal school at Monmouth Ore.; The State Normal School at Lewiston, Idaho.

The College of Hawaii is fortunate in having connected with it Prof. Vaughan MacCaughey who is a most able naturalist and a lover of all the wonderful out of door life of Hawaiian Islands. Prof. MacCaughey does not let us forget him for he writes concerning the food plants of ancient Hawaii to the *Scientific Monthly* and of several remarkable plants to the *American Journal of Botany*. The most interesting account of "The little end of Hawaii" to the *Journal of Geography* and gives an account of the orchids of Hawaii to the *Plant World*. He gives a most practical paper in Science on the Botanical field excursion in collegiate work. We are glad that we have Prof. MacCaughey to make such interesting reports to us of life in the land of his adoption.

In the very interesting conservation, *Bird and Arbor Day Bulletin*, published by the State Board of Education, of California, Dr. Margaret McNaught strikes this timely warning note:

"Too often the observance of the day is an end in itself. The people of the school district gather on the school grounds. An appropriate program, planned by the teacher, is successfully carried out by the children, at the close of which all those assembled show much interest and industry in the planting of trees and shrubs. Then the shovels and spades and watering pots are gathered together and placed in wagons and automobiles; the fathers, mothers and children laughingly crowd in among them and everybody goes home happy in the consciousness of a day well spent. March 7th has been celebrated.

Next morning interest has waned. The children return to school and continue their school studies, while the trustees and other "grown-ups" go about their regular round of duties. The trees, planted with so much formality are neglected, and for want of water droop their branches under the hot rays of the noonday sun, then drop their leaves and die. They, too, were only a part of the celebration of the day.

Nothing could be farther from the spirit of the law that sets aside Luther Burbank's birthday in the school year to be known as Conservation, Bird and Arbor Day."

A paper by Pres. Charles W. Elliott, published by the Rockefeller general education board entitled "Changes needed in American secondary education"



is one of the announcements for the modern school experiment to be tried out at Columbia and it gives expression to those things which the Nature-Study movement has stood for since its inception. This is a matter of rejoicing to us all and especially so to Dr. Edward F. Bigelow, who gives a lengthy editorial in *The Guide to Nature* showing how Pres. Elliott's ideas were a part of the Agassiz Association plan from the first. Dr. Bigelow pays tribute to Mr. Harlan H. Ballard for his great work in first organizing the Agassiz Association and thus bringing to bear an important influence in the direction of this new education upon the children of the United States.

Prof. P. G. Holden, Director Agricultural Extension Department, International Harvester Company, has issued a very timely and much needed circular, on how to vitalize the teaching of agriculture in the rural schools; he says, with truth, "the teaching of agriculture in rural schools never will be a success so long as we teach the same thing over and over again, year after year, or allow the teacher to skim all the branches and leave a subject barren and uninteresting for the teacher who follows the next year," and his remedy for this is to rotate the subjects and suggests a four year rotation. "This method enables us to teach more agriculture, eliminates repetition, gives us a new field subject each year, keeps interest alive and keen, does not kill the subject by skimming or teaching the same thing over and over again."

Teachers interested should send to the International Harvester Company, Chicago, for the circular; its suggestions are truly valuable.

The Brooklyn Botanic Garden offers a six weeks' summer course in gardening from July 5 to August 16. The course is not only one of theory but of practical outdoor garden work in gardening and also work in the garden with children, so that one is prepared to work in children's gardens or in community gardens. The fee for this course is \$20.00 For further information write to the Secretary Brooklyn Botanic Garden, Brooklyn, N. Y.

Miss Margaret Aherne, who has been teaching Nature-Study in the Gary schools, writes of her live equipment for teaching:

"I have two opossums and one has about eight young. I also have two nice fat rabbits now besides an alligator, pigeon, rats, turtles, frogs, salamanders, etc. I have nineteen new gold fish and a new castle. Altogether I have about 70 fish. My number of snakes increase daily. At the last counting I had fifteen."

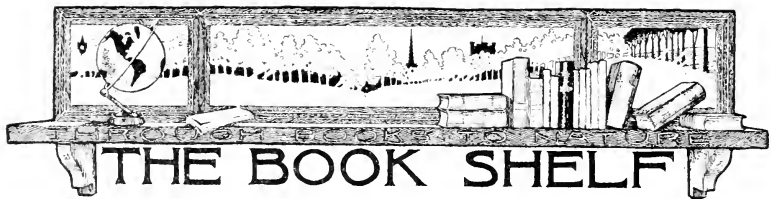

*Primer of Bird-Study.* Ernest Ingersoll, The National Association of Audubon Societies. 1974 Broadway, New York City. Price 15 cents.

The beginning of bird study should consist of understanding the wonderful adaptations in the structure of the bird to its mode of life. This sounds as if it should be the final effort of bird study also and both are true. But the writer knows whereof she writes for she has taught small children about birds and began with the adaptations which interested them far more than the learning to know different birds by name, for the child wants to know "what they do" and "how they do it." This primer of Mr. Ingersoll's is just what the teacher needs for the start. It discusses feathers and their uses, colors and growth, molting, use in flying, the wings, tails, and head dresses, feet, bills; the faculties of birds—their senses of touch, sight and smell; the food, alimentary tract, the egg, and incubation; nests and their purposes.

It is an admirable little book and gives the teacher just the information she should have to interest the children in the life of birds.

*Our Common Birds*, by D. W. Hamilton, McIndo Publishing Company, Toronto, and 912 Grand Ave., Temple Building, Kansas City, Mo.

This delightful book is just what the Nature-Study teacher needs, for it is written especially from the Nature-Study standpoint. Dr. Hamilton has been one of the efficient workers in nature-study in the Dominion of Canada for many years and he understands well the needs of the teacher. It begins with short accounts, of the game birds, the birds of prey, the woodpeckers and a color key for their determination, the sparrows and a color key for their determination, the thrushes with a color key and finally is given a color key to the warblers. Dr. Hamilton has a happy faculty for giving interesting titles to his chapters, "The bird with a chiseled beak" covers the woodpeckers; "Tree inspectors," the nuthatches and chickadees; "The wily bird," the crow; "Friendless birds," the blackbirds; "The live diadem," the hummingbirds; "Birds with special menu," the cuckoo; "A well groomed visitor," the wax-wing, etc. Altogether this is a most attractive and useful little book.

*The Bird Study Book.* T. Gilbert Pearson, Secretary Natural Association, Audubon Societies, Doubleday Page & Co. New York City. Price \$1.25.

This book is the natural outgrowth of Mr. Pearson's wide experience as Secretary of the Audubon Societies. It discusses first acquaintance with the birds, Notebooks, Blanks for reporting, Artificial cover in hiding to watch birds, How to study the birds during nesting season, and care of young, Bird migration, Winter habits of northern birds, Economic value, The traffic in feathers, Bird reservations, Bird-protective laws and their enforcement, The making of

bird sanctuaries, and winds up with a chapter relating what various teachers have done for bird study and gives rules for forming bird-study clubs. Mr. Pearson has brought together in this volume very practical information for the bird lover and the teacher. There are 16 full page illustrations from photographs and many line drawings.

*The Book of the Peony*, Mrs. Edward Harding. 260 pp., 44 illustrations in color and black and white. Octavo. Handsome cloth. J. B. Lippincott Company. Net \$6.00.

It is a pleasure to take some books in the hands without reference to the contents, and this is one of them; as one opens it one is still more pleased for first of all the eye revels in the beautiful and artistic colored plates and the beautiful type and wide leisurely margins. The peony has always appealed to the reviewer from the time when as a child she worshipped the vivid, purplish red which every June brought forth in the farmhouse garden, and it still continues giving her a gaspy sort of happiness when she looks at the row of the pink and white and red beauties that grace her present garden. But this book induces a still more "gaspy" pleasure for it reveals undreamed of interesting things about peonies.

First of all, they have a history that would make the worshipper of pedigree envious, for it reaches back to mythology. The reason for this pedigree lies in the fact that peonies have played such an important part as medicine, *P. officinalis*, the one that excited our childish admiration, is a native of southern Europe and has been used for medicine so long that it is a part of mythology. The original white peony has an equally interesting history, being a native of China from whence Japan imported it early in the Eighth Century.

After the chapter on the history follows a description of the eight types of peonies which have been developed and six short lists of twelve each of the most desirable varieties are given; then follows a main list of peonies tabulated as to introductory type, list, color, size, season, fragrance, habit of growth, special value. This table covers nineteen pages. The chapters that follow deal with the following topics: Extending the period of Bloom, Purchasing, Where to plant and how to prepare the soil, Planting and cultivation, Propagation, The tree peony—Descriptions and history, Tree peonies; Cultivation, Propagation and best varieties, Various species of the peony. And last of all in the Appendix is given Diseases of the Peony—by the highest authority in America, Prof. H. H. Whetzel.

Mrs. Harding is a practical gardener and has one of the best peony gardens in this country. This accounts for the delightfully sympathetic style in which the book is written and at the same time for its practical value.

*Judging Horses—As a Subject of Interest in Teaching School.* H. P. Barrows, U. S. Dept. Agr. Bulletin 487, Washington, D. C.

A bulletin of 30 pages is introduced by some very practical suggestions of class room discussion of the subject. Then follows very terse and well illustrated clear directions for the judging of horses including students' score cards for draft and light horses.

*Animal Micrology.* By Michael F. Guyer. Chicago: University of Chicago Press. Price \$2.00, postage extra (weight 1 lb. 10 oz.)

The development of microscopical technique during recent years has been so great that too often it seems to the uninitiated a science in itself rather than an aid to study. The standard texts devoted to the subject are encyclopaedic in character and however indispensable as laboratory reference books are altogether formidable for the beginner. The result is that the undirected student of biology, wishing to prepare his own materials, is bewildered and discouraged by the multiplicity of methods and by complicated directions.

The need for a guide, in English, which could take even the beginner through the maze and which could insure his mastering of the essentials of the subject, was met some ten years ago by the publication of the first edition of Professor Guyer's "Animal Micrology." In clear, simple language, it presented the principles of technique, and then starting the student with his own material, led him step by step to his goal—the carefully prepared, completed slide, ready for study.

The favorable reception accorded the first edition has led the author to bring out an enlarged and completely revised second edition. "The general plan of the book has not been altered" but many sections have been entirely rewritten, and two new chapters, one, on 'Cytological methods', the other on 'Drawing' have been added. The discussion of the principles of the microscope is very brief, on account of the available excellent treatises of Gage and of Carpenter.

The various methods of imbedding and sectioning, of isolation, staining, and mounting are clearly and explicitly discussed. In addition there are chapters devoted to the essentials of embryological methods, blood examination, and bacterial examination and to the preparation of invertebrates and objects of general interest. The memoranda at the end of each chapter, and the consideration of difficulties likely to be encountered will prove helpful to the laboratory worker and the advanced student as well as the beginner.

The author has met his aim of making the entire book practical, omitting the unessential, and above all, giving definite statements. Students and teachers of animal biology are fortunate in having so helpful and practical a work available.

*Tree Wounds and Diseases,* A. D. Webster, J. B. Lippincott Company. 215 pp. 32 full page plates. \$2.50.

Only a few years since the name Tree Doctor was a term of derision just as was Bugologist applied to the Entomologist a few years earlier. But both these titles have earned their place in the honorable professions through saving the trees from the ravages of insects and diseases. This volume is opportune as the author says it is written with the distinct object in view of bringing home to owners of trees, or those in charge of such, that at a small outlay of labor and expense, the lifetime of old, historic or accidentally damaged specimens may be greatly extended. The book discusses in a clear and popular manner: The management of decaying trees, Hollow trunks and their treatment, Supporting heavy and diseased branches, Injured bark on root and

stem, Pruning diseased trees, Injurious influences from soil or atmosphere—Fungus growth on trees—Insect attacks and their remedies, Injuries from animals and birds, Fruit trees and their enemies, Preventing diseases, Accidents and diseases to which trees are liable, Preservatives and materials. There are many illustrations. This book should be in the library of every tree lover and orchardist.



The Bird Fountain in the Editor's Home Garden.

# AMERICAN NATURE-STUDY SOCIETY

CORNELL UNIV., ITHACA, N. Y.

PLEASE HELP TO SAVE OUR NATIVE PLANTS BY PROMISING

To protect our native plants,  
Not to destroy rare wild-flowers and ferns,  
Not to injure any shrub or tree and  
Not to set fire to the fields or woods.

Name .....

Address .....

Date .....

---

## American Fern Journal

---

Official Organ of the American Fern Society

Issued quarterly: Subscription, ninety cents per year.

Includes articles of both technical and popular interest with illustrations.

Editor, R. C. Benedict, Ph. D., 322 East 19th St. Brooklyn, N. Y.

Business Manager, E. J. Winslow, Lasell Seminary, Auburndale, Mass.

### *The Guide to Nature*

Edited by EDWARD F. BIGELOW

A Monthly Magazine from the Naturalist's Point of View.

An interchange of observations by students  
and lovers of nature.

*Nature is good in the school, because it is good  
anywhere for all people.*

Subscription \$1 a year      Four months' trial 25c.  
Single copy 10c.

**THE AGASSIZ ASSOCIATION**

**ARCADIA**

**SOUND BEACH      :      :      CONNECTICUT**

Kindly mention The Nature-Study Review when replying to advertisements

# THE NATURE-STUDY REVIEW

VOL. 13

SEPTEMBER, 1917

No. 6

## THE COMMON BUTTERFLIES



THE BUTTERFLIES afford ideal material for nature-study, and especially for interesting the pupils in the mastery of a group. In almost any locality outside of the large city, there may be found in the course of a season thirty or forty species of butterflies, and at least twenty of these are common. Because the number is so small, the species are easily learned and most of them may be identified while on the wing. The teacher should bear this point in mind for it is a great advantage for a child to be able to identify a creature without having to kill it to make sure.

In 1906 when the editor was conducting the Home Nature-Study Course for Cornell University, a butterfly leaflet was issued as a part of this course. This leaflet was very popular at the time and there are still many requests for it from teachers and pupils of many states although the leaflet has been long out of print. Therefore, it has seemed wise to reprint it with such additions as will make it applicable to a wider range than New York State for which the original was written.

A pleasure similar to that afforded by the sight of a beautiful flower is experienced when the eye rests upon a bright hued butterfly. It may be balancing itself above its partner in beauty, the flower which gives it nectar, or it may be following the graceful curves of its path in the air, or if frightened it may zigzag by so swiftly that the eye only catches a bit of moving color; and although almost every one is attracted by these beautiful creatures, yet aside from two or three of the most common species very few people know their names or their habits. Yet each one of the butterflies has a most interesting life-history, and some of them are of great economic importance.

## THE ECONOMIC IMPORTANCE OF BUTTERFLIES

For the most part butterflies are not injurious; although while in the caterpillar stage they feed upon vegetation, most species



THE BLACK SWALLOWTAIL

Expanse three and one-half to four inches. Color brownish-black, the front wings spotted with yellow, the hind wings bearing yellow and blue spots. There is a red eye-spot at the inner angle of the hind wing.

live upon weeds of various kinds, and those that feed upon the leaves of trees rarely occur in such numbers as to do damage. The cabbage butterfly is a notable exception; it came to us from Europe and is now a widespread pest that would work destruction to the entire crop of cabbage and other cruciferous garden plants

if left alone. The caterpillars of the black swallowtail occasionally occur in sufficient numbers to damage celery, and the young of the giant swallowtail do injury to the foliage of orange trees; occasionally the caterpillars of the mourning cloak do some damage to elms. However, all butterfly caterpillars are easily gotten rid of by spraying the foliage on which they are feeding with poisoned water. The benefits conferred by butterflies are only partially known and little appreciated. Very many flowers depend upon butterflies for carrying and bringing pollen. The black swallowtail is especially beneficent in this respect. A large number of the species assist in cross pollinating the flowers of the plants on which their young feed and thus they pay back their debt. One little radical, the wanderer, has departed from the traditions of the butterfly family; its caterpillar feeds upon plant lice and thus is very helpful.



## THE LIFE HISTORY OF A BUTTERFLY

The life-history consists of four stages:

*First.*—The eggs which are laid upon the food plant by the mother butterfly; these eggs are often exquisite in color and beautifully ribbed and pitted so that when seen through the microscope they look like gems.



Eggs of Black Swallowtail, enlarged.

*Second.*—The caterpillars which hatch from these eggs and which feed upon the food plant until fully developed. Before reaching its full growth,

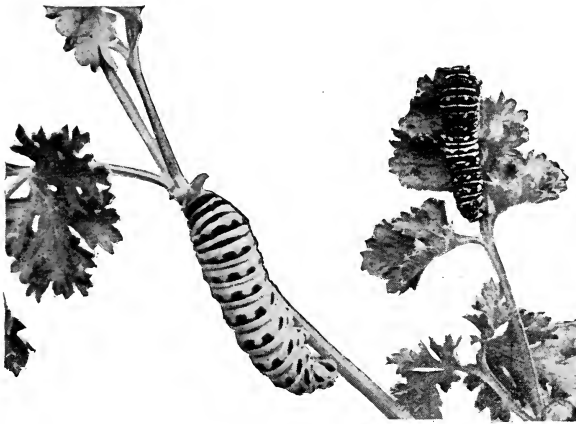

Caterpillar of Black Swallowtail in two stages of growth. The larger one has the scent organs protruding.

the caterpillar sheds its skeleton-skin four or five times; often this change of skin makes a change in the appearance and in the color of the caterpillar.

*Third.*—The pupa state or chrysalis. When the

caterpillar is full grown it sheds its old skin and appears in a very different form, that of the chrysalis or pupa. The pupæ of the butterflies are never protected by a cocoon as are the pupæ of moths. This is one of the chief differences between moths and butter-

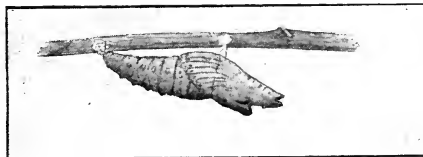

Chrysalis of Black Swallowtail

flies. The caterpillar, before it changes to a pupa, makes a button of silk and sometimes also a loop of silk by which the pupa is suspended. As the insect when in the pupa or chrysalis state is helpless and unable to move, it is, therefore, an easy prey to birds and other enemies; thus the chrysalis is usually inconspicuous and placed in some position where it is not easily detected by even the keenest eyes.

*Fourth.*—After a time the pupa skin is shed and from this comes the winged insect in all its beauty of color and form.

### HOW TO STUDY THE BUTTERFLIES

The caterpillars may be found on their food plant and reared indoors. This requires a great deal of care in providing fresh food and in looking after the wants of the little prisoners. This is the best way to study the insects, as we thus become acquainted with the caterpillar and its habits and also the chrysalis; and when finally the winged insect emerges we may become familiar with its colors and markings before we set it free to carry on its work of perpetuating the species and of carrying pollen for the flowers.

Or we may catch a butterfly with a net without injuring it and let it loose in the room where we can study it at close range and get thoroughly acquainted with its size, form and colors. This is an excellent way.

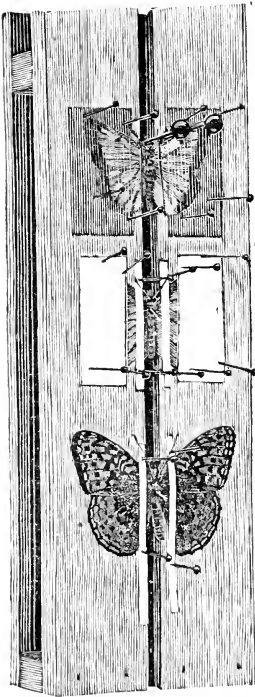

Spreading Board

The most common way of studying these insects but perhaps not necessarily the best, is to make a collection of butterflies. This involves the catching of the insects in a net, and killing them in a cyanide bottle, or by pinching the thorax, and then spreading the wings carefully, letting them dry extended, and then placing the specimens in a box for safe keeping. Every beginner experiences great trouble in keeping such specimens free from the little pests

which destroy them. The boxes of insects in any museum have to be looked over carefully every month and such as are infested treated with the deadly fumes of some gas. Undoubtedly the best and cheapest way for amateurs to mount their insects in permanent form is to use the Riker mounts which consist of shallow cardboard boxes with glass covers and filled with cotton. The size of box large enough for most of our butterflies costs fifteen cents each, and they come in cases, a dozen in a case. The butterfly is spread and placed on the cotton, the cover put on and sealed with gum paper and the specimen is safe for all time. As there is a box for each, any specimen may be passed around and studied by itself.

Such a collection of butterflies is a great help to a teacher as she is thus able to bring a page from nature's book into the schoolroom for the pupil's enjoyment and enlightenment. However, we by no means advise that the pupils themselves make a collection of insects, or that they be encouraged to do so.

While we do not advise the children to make collections of insects our reasons for doing so are based quite as much upon other grounds as upon that of developing cruelty in the child. The taking of life of the lower animals is a matter that had best not be too much dwelt upon before children, for we cannot be consistent in our teaching and they soon discover it. For who shall say that the cat which catches and eats the robin is more culpable than the person who eats lamb chop for breakfast, thus sacrificing the life of an innocent and playful creature to satisfy his appetite? And in the wider view of the Creator and his creatures, the life of a butterfly is no more sacred than that of the housefly or a mosquito. It is far safer to let these questions alone in our teaching and cultivate in the child an interest in the lives of the lower animals, thus bringing him into kindly relations with his little neighbors of the field, so that he will naturally respect their rights. It is the boy who knows the birds and loves them, who will not shoot them; it is the child who knows the butterfly by name and something of its interesting habits who will refrain from crushing the life out of its fragile body.

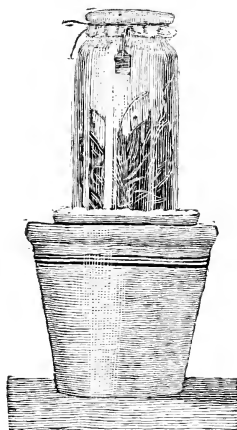

A Breeding Cage

We cannot eradicate cruelty by punishment or repression; but we may crowd it out of the child's character, by putting in its place little by little the humane and tender sentiments which inevitably follow a knowledge of the life and habits of even the lowest creature.

### FIFTY COMMON BUTTERFLIES

In the following descriptions the measurement of the butterfly is made across the spread wings from tip to tip; unfortunately, it was not practicable to have the pictures of all the butterflies natural size. It must be borne in mind that individual butterflies of the same species may vary in size somewhat. When the size of the caterpillar is given it means the fully grown larva just before it changes to a pupa.

#### THE SWALLOWTAILS

These are large handsome butterflies and get their name because of the prolongation of the hind wings in a manner suggesting the tail-feathers of a swallow. The caterpillars have a pair of scent organs just back of the head, which they can thrust out at will. These are supposed to protect them from the attacks of birds by rendering them disagreeable to smell and probably to taste.



THE TIGER SWALLOWTAIL

Expanse, three and one-half to four inches. Colors pale straw-yellow marked with black. On the hind wing near the inner angle are blue and red spots.

*The Tiger Swallowtail.*—This magnificent creature flies about leisurely and is fond of strong odors whether they be fragrant or otherwise. It is especially fond of tobacco smoke and will often be seen following in the wake of a smoker. The caterpillar has large eye-spots on the thorax, and it has a pretty habit of making a silken, spring mattress to rest upon when it is not eating; it makes this by weaving the web of silk across the leaf pulling the edges of the leaf slightly together. Food plants, ash, birch and poplar.

*The Black Swallowtail.*—This graceful insect is often found about our houses visiting the flower gardens. It is one of the most important pollen carriers among the butterflies. The male is

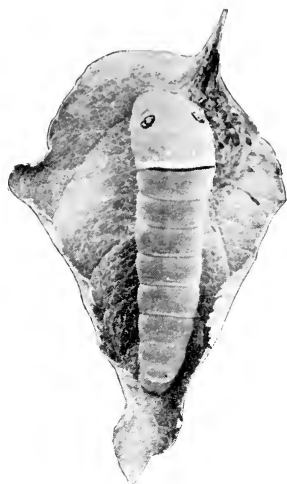

Caterpillar of the Tiger Swallow-tail resting on its silken mattress.



THE GIANT SWALLOWTAIL

This greatest North American butterfly has an expanse of five and one-half inches. It is black and marked with yellow bands diagonally across the wings and near the outer border.

smaller than the female, and has two complete rows of yellow spots on both wings. The caterpillar is mostly black and spiny when young but later it is adorned with green and black crosswise stripes, the black stripes enclosing six yellow spots. Food plants, caraway, parsley, celery and wild carrot.

*The Giant Swallowtail.*—This is the largest butterfly in North America. It is a southern species and its caterpillars attack the

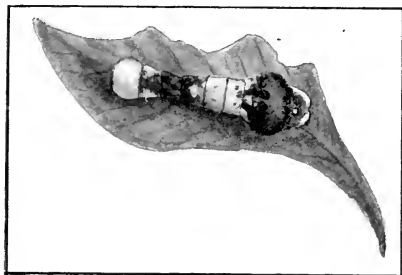

Caterpillar of Giant Swallowtail.

leaves of citrus fruits. It is a disagreeable looking creature, colored to imitate bird lime, and when disturbed, erects its head, throws out its scent horns and fills the whole neighborhood with an almost unbearable stench. It also feeds upon prickly ash and lombardy poplar and is sometimes found in the North.

The butterfly is magnificent and creates the greatest excitement when it appears in the Northern States as it sometimes does in late summer.

*The Zebra Swallowtail.*—The wings of the zebra are barred with blackish and greenish white which make it a striking butterfly.

The length of its graceful tails is dependent upon the lateness of the summer. It is common in the Southern States where it goes through several generations each year. The caterpillar feeds upon pawpaw, spicebush and huckleberry.

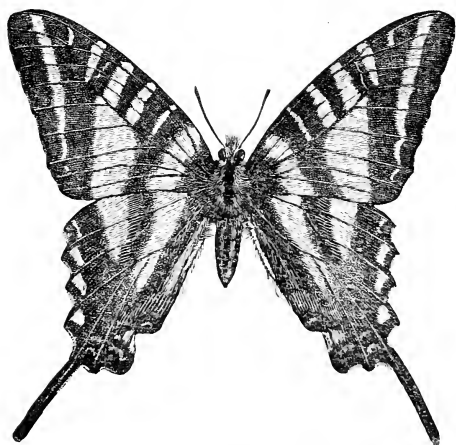

THE ZEBRA SWALLOWTAIL

The wings are barred with blackish and greenish white. Near the base of each tail-like prolongation of the wings is a blood red spot, and beyond this are two purplish blue crescents. The tails to the wings are paddle-shaped and rather short. The caterpillar feeds upon spicebush

and saffras. It has eye spots on its thorax. This species is common in the Southern States. For figure see p. 254.

*The Blue Swallowtail.*—This is another black velvety butterfly with a blue shimmering sheen playing over its wings in the sunshine. The fringe on the outer margin of its wings is alternately black and white and each wing may have a row of whitish spots just inside the border. The expanse of wings is from three and one-half to four and one-half inches. Its caterpillars feed upon Dutchman's Pipe, Virginia snake-root, and black bindweed. It is a common species in the South and might be taken for the greenclouded species except that it has no orange spots on the hind wings.

## THE PIERIDS

### THE WHITES

*The Cabbage Butterfly.*—This is the white butterfly common near every garden in which grows cabbage or its near relatives. We had native species of cabbage butterflies which did comparatively little damage to gardens, although they were found quite commonly prior to 1870; but this emigrant *Pieris rapæ* came to us from Europe getting its foothold in New York State in 1868. Now it has driven out all of our native species; they have literally taken to the woods and are found only occasionally flitting about the wild cruciferous plants. The velvety-green caterpillar of the cabbage butterfly is very destructive and is well known. It feeds on other cruciferous garden-plants but prefers cabbage.

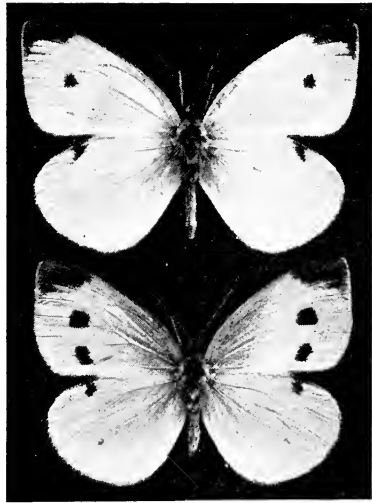

THE CABBAGE BUTTERFLY

Expanse an inch and three-quarters.  
Color white with black spots. Male  
above, female below.

### THE ORANGE-TIPS

The orange-tips are seldom seen; they are smallish white butterflies marked with black and have the lower sides of the wings

marbled and netted with green. Many of the species, especially the males, have the front wings tipped with orange which gives them the name. Most of the species are found in the far West, only two are occasionally found in the East.

*The Flacate Orange-Tip.*—This butterfly has the apex of the front wings prolonged into a hook shaped point. Only the males have the front wings tipped with orange. The caterpillar feeds on cress, shepherd's purse and other crucifers.

#### THE YELLOWS

*The Roadside Butterfly*—This is the most common representative that we have of the yellows, and it may be seen in the summer in great numbers flitting above the flowers of our roadsides, or settled for a social drink about some mud puddle in the road. Its caterpillar is small, green in color, and feeds on clover, vetch, lupine, etc. It is so well concealed by color that it is rarely found.



THE ROADSIDE BUTTERFLY

Expanse, one and three-fourths to two inches. Color bright, sulphur-yellow. Wings bordered with blackish. Spot on the fore wing black and on the hind wing orange-yellow.

dark spot in front of the middle of the front wing extends up and down and is a mere line, looking like a closed eye. The caterpillars feed upon cassia, clover and senna. The species is common in the Southern States.

*The Dog's Head.*—The wide black border on the front wing of this butterfly outlines on the yellow a head that resembles that of a duck quacking more than that of any dog. However, the picture on the wing of the female is slightly like the profile of a poodle's head. The black spot forms a large and startling eye. The caterpillar feeds upon false indigo and clover. This species is abundant in the south western United States and Pacific Coast. Its wing expanse is about two and one-half inches.

*The Little Sulphur.*—This is a pocket edition of the roadside butterfly, marked like it except that it has a dot instead of a spot

*The Sleepy Yellow.*—This butterfly has a wing expanse of not quite two inches. Its wings are bordered with a broad black band and the



on the front wing. Its expanse is less than one and one-half inches. It is common in the Southern States and northward. Its caterpillar feeds upon cassia and other legumes, preferring the fine-leaved varieties.

*The Orange Sulphur*.—This species resembles the roadside butterfly in size and markings but is orange instead of lemon yellow. It is found abundantly in the Mississippi Valley. Its caterpillars feed upon clover, vetch, etc.

*The Cloudless Sulphur*.—This splendid butterfly, the most beautiful of all the yellows, has an expanse of two and one-half inches and looks like a California poppy floating off its stem. The male is pure yellow with no markings, but the female has just a suggestion of black border on the outer edge of her wings and a black spot in front of the middle of each front wing. It is a common species in the Southern States, and late in the season pushes northward. The caterpillars feed upon cassia and other legumes.

## THE NYMPHS

### THE FRITILLARIES OR CHECKER-BOARD BUTTERFLIES

These are reddish-brown butterflies with many black spots on the upper sides of the wings giving them a checkered appearance; and with many silver spots on the lower sides of the wings. When we were children we used to call these round, silver spots "butterfly money," and it was one of our pastimes to gently seize one of these butterflies when we found it sucking nectar from some thistle blossom and count its money before we let it go.

*The Gulf Fritillary*.—This is a bright copper butterfly that bears some resemblance to the monarch since its veins in the outer portions of the wing are black. It has an expanse of two and one-half to three inches. It can always be distinguished from other butterflies by the form of the silver spots on the lower side of the wing which are bar-shaped rather than coin- or crescent-shaped. The caterpillars are spiny and feed upon the leaves of the passion flower. The species is found in the South from the Atlantic to the Pacific.

*The Regal Fritillary*.—This is the most magnificent of all the fritillaries, having an expanse of from three and one-half to four inches. Its front wings are copper color with dark borders, but its hind wings are black with yellowish or light spots. Underneath, the front wings are orange and the hind wings are a rich olive brown

ornamented with nearly thirty large silvery white spots. While in general it resembles the great spangled fritillary and the silver-spot, the black hind wings distinguish it from these species.

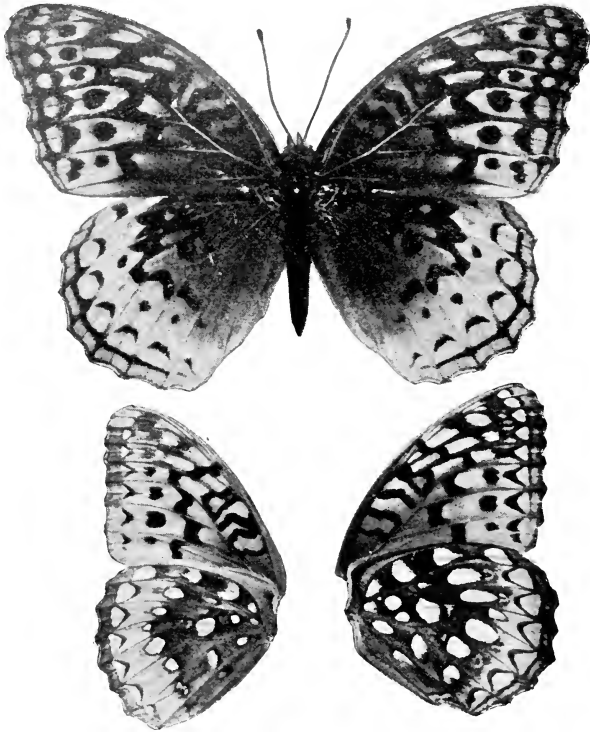

#### THE GREAT SPANGLED FRITILLARY

Expanse about three inches. Color orange (which fades to a dull brown late in the season) marked with black, the wings shading to brown next to the body. Undersides of the wings of the Great Spangled at the left; of the Silver Spot at the right.

*The Great Spangled Fritillary and the Silver Spot Fritillary.*— These two are of the same size and marked very similarly. The only way to distinguish the two species is to study the lower side of the hind wings; in the great banded species there is a broad, buff band inside the silver spots that border the wings; it is one-fourth as broad as the wing itself. This band is very much narrower in the silver spot. The caterpillars of these species are velvety black and spiny, and feed on the leaves of violets.

*The Variegated Fritillary.*

—This is another southern species and it has the real fritillary markings on the upper sides of the wings; there are no silver spots on the lower sides of the wings which are marbled with brown and white. It has a wing expanse of two and one-half inches. Its caterpillar is thorny and feeds upon passion flower, mandrake, violet and some other plants.

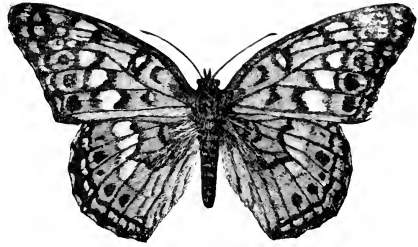

THE VARIEGATED FRITILLARY

The wings are copper red crossed near the center with a paler band and the markings are blackish; no silver spots on lower side of wings.

*The Silver Bordered Fritillary and the Meadow Fritillary.*—These are two little fritillaries which resemble each other very much, but

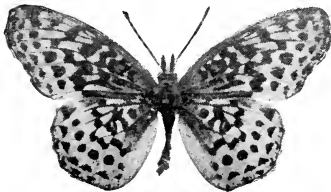

may be easily separated by the fact that the silver bordered has the silver spots on the lower side of the hind wings, while the meadow has not a butterfly dollar on its wings anywhere. The caterpillars of these species are small, mottled green and spiny. They feed upon violets.

THE CRESCENT SPOTS 

*The Silver Crescent and the Pearl Crescent.*—These are two little

butterflies which may be distinguished from other orange-yellow, small butterflies because there is so much of brown or black upon the wings that it is hard to tell whether that or the orange is the ground color. The lower sides of the wings are much paler than above and are marked with various shades of yellow in most complicated patterns. The caterpillars of these species are black

SILVER BORDERED FRITILLARY above; MEADOW FRITILLARY, below. Expanse, one and three-quarters inches. Color orange-yellow spotted with black. The underside of wings shows the "meadow" at the right.

marked with yellow or orange, spiny, and feed on sunflowers, asters and other composite plants.

*The Baltimore.*—This is another crescent spot, but is very striking in appearance. It is found near swampy places. Its caterpillar is black and orange banded and striped and spiny. The caterpillars of one brood live together like a happy family,



THE BALTIMORE

Expanse two inches. Color black with outer marginal row of reddish-orange spots and two parallel rows of very pale yellow spots.

rounded by plenty of food. The food is snake head.

#### THE ANGLE WINGS

These butterflies are so called because the edges of their wings look as if they were cut in sharp notches and scalloped with a pair of scissors; they are among our most interesting and beautiful butterflies.

*The American Tortoise Shell.*—This striking butterfly sometimes passes the winter as an adult and sometimes as a chrysalis. Its caterpillar is black with greenish sides and sprinkled with white raised



PEARL CRESCENT,  
SILVER CRESCENT.

Expanse one and one-half inches. Color orange-yellow with black markings.

weaving leaves around themselves for protection; a queer thing about them is that during late summer the whole brood suddenly stops eating voluntarily and waits for winter to pass, although sur-



THE AMERICAN TORTOISE SHELL  
Expanse two inches. Wings blackish crossed by a broad band of orange brown which shades to yellow on the inner side.

spots; it is spiny. The caterpillars of the same brood live together feeding on the lower sides of the leaves which they fasten together making a protective abode. The food plant is nettle.

*The Compton Tortoise.* — This butterfly resembles very much the polygonias even having the "embroidered" initial on the lower side of the hind wings. However, it differs in one particular. The hind margin of the front wings is straight and not



THE COMPTON TORTOISE

Expanse two and one-half inches, mottled with dark red and ochre yellow, like the colors of a tortoise shell. A white spot is on the front of each wing near the tip. The hind wings on the lower side each bear a small L-shaped silvery or white mark.

incurved. Its caterpillar is greenish in color more or less speckled with lighter color. It has black, bristly spines and the caterpillars of the same brood feed in a flock. The food plants are birch and willow.



THE MOURNING CLOAK

Expanse two and one-half to three and one-half inches. Color purplish-brown appearing black when flying. The wings have a broad, yellow border sprinkled with brown and just inside the border a row of blue or lavender spots.

*The Mourning Cloak.* — This butterfly which is well known in Europe is very common here. It winters as a butterfly and is the earliest of all our butterflies to appear in the spring. Its caterpillar is velvety black covered with white raised dots, and a row of red spots along the middle of the back. It has

rows of black spines. It feeds on elm, willow, poplar and other trees.



"BOO!"  
THE BUCKEYE

*The Buckeye*.—This is a southern butterfly that pushes northward late in the season. It has two eye spots on each front and hind wing, a large one and a small one. The small one on the front wing is often indistinct. Its general color is brown with a few copper red markings; there is diagonal yellow band across each front wing. A very similar species is common on the Pacific Coast. The caterpillar is dark gray with lengthwise yellow stripes and spotted with yellow and orange. It is ornamented with branching spines. It feeds upon gerardin, figworts, snapdragon and plantain.

### THE THISTLE BUTTERFLIES

Three of the angle wings are called the thistle butterflies because they are particularly fond of the nectar of thistle blossoms, and each one bears on the lower side of the wings a band of rich rose-color, which well matches the color of the thistle flowers.

*The Red Admiral*.—

This is one of our most striking and beautiful butterflies. The wings beneath are beautifully mottled and the front wings bear a diagonal band of rich rose-red. Its caterpillar is dull yellow, mottled with black with a yellow stripe along the side; it has many spines. It feeds upon nettles and hops.

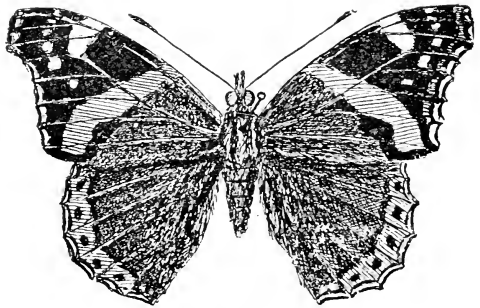

THE RED ADMIRAL

Expanse a little less than two and one-half inches. Color purplish-black with white spots near the tips of the front wings. Orange-red band across front wings and bordering middle part of hind wings.

*The Painted Beauty and Cosmopolite*.—These two species resemble each other very much; each has the hind half of the front wing colored rose-pink on the lower side; on the hind wing of the painted beauty are two eyespots while on the cosmopolite there are five or six smaller ones in a row. The caterpillar of the painted

beauty is velvety black with cross lines of yellow and with a row of white spots on each side back of the middle. It has bristly

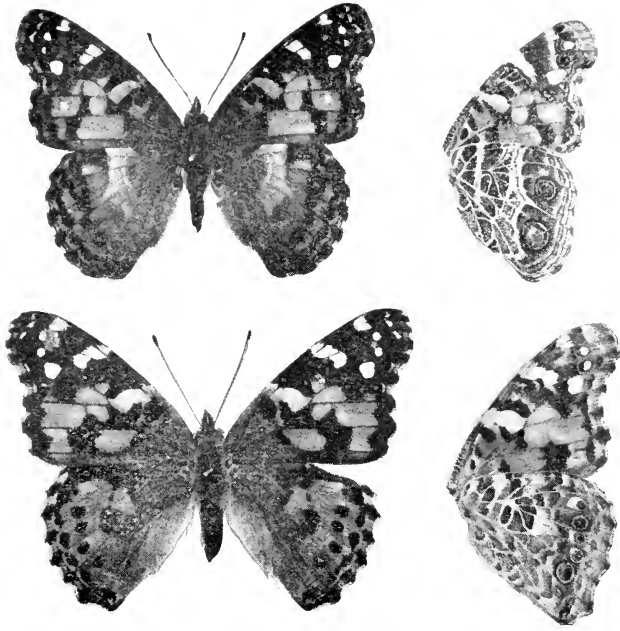

THE PAINTED BEAUTY, above, THE COSMOPOLITE, below showing under sides of wings at the right. Expanse of wings about two and one-half inches.

spines; it feeds upon everlasting and allied plants. The cosmopolite caterpillar is mottled, greenish-yellow with black and yellow stripes along the side. It has bristling yellow spines; its food plants are thistle, willow and everlasting. The cosmopolite has the widest distribution of any of our butterfly species. It is found in every part of the world except South America and the Arctic regions.

#### THE POLYGONS

These are distinguished from the other butterflies not only by the sharp notches and angles of the edges of the wings, but also by having the hind margin of the front wing cut out in a graceful curve. Each species has on the lower side of the hind wing near the center an initial or punctuation mark wrought in silver, this mark varying with the species. The flight of the polygons is very

erratic; they dash about making quick angles so that the eye cannot follow them. While the upper sides of the wings are bright orange red and quite striking, the lower sides of the wings are mottled in dull colors so that they resemble dead leaves or grass. All one of these butterflies has to do to become invisible when resting on the ground, is to close its wings above its back, and it is then almost impossible for the eye to detect it.



THE VIOLET TIP

Expanse two and one-half to three inches. Color rich orange red spotted with black. The margins of the wings and tails violet color. The hind wing bearing a large silver semicolon on the lower side, shown at the right.

*The Violet Tip.*—

This is the largest of the polygons and the most graceful in form of all butterflies. It winters as an adult. The caterpillar is yellowish-brown with irregular spots and marks of lighter color. It has many branching spines, one pair being on the top of the head. It feeds on elm, hop, nettle, linden and hackberry.

*The Hop Merchant.*—This looks on the upper side like a dwarf violet tip, for the margins of the wings are tinged with violet. It hibernates as a butterfly and is one of the earliest that we see in the woods in the spring. Its caterpillar is about an inch long, dark brown or greenish with blotches and lines and adorned with thorny spines one pair of which is on the head. It feeds on hops, nettle and elm. The chrysalis is a beautiful object ornamented with



THE HOP MERCHANT

Expanse two inches. Color bright orange-red with black spots. The borders of the wings dark brown shading off to violet at the margin. The "initial" on the lower side of the hind wings is like a badly made G.



knobs that shine like the precious metals. There is a superstition that if these knobs are golden the price of hops will be high; if they are silver, the price will be low.

*The Green Comma.*—This always hibernates as a butterfly. It may be distinguished from the gray comma, which it very much resembles, by the green tinge quite noticeable in the darker markings of the upper side of wing, and by the amount of olive green and the very different pattern on the lower side of the wings, and a quite different initial which is much like that of the hop merchant. Its caterpillar is a little more than an inch long, reddish or yellowish in color with a large patch of white on its back. Its branching spines are light colored. It eats the leaves of black birch, willow, alder, currant and gooseberry.

*The Gray Comma.*—This butterfly always hibernates as an adult and appears early in the spring. It especially frequents orchards.

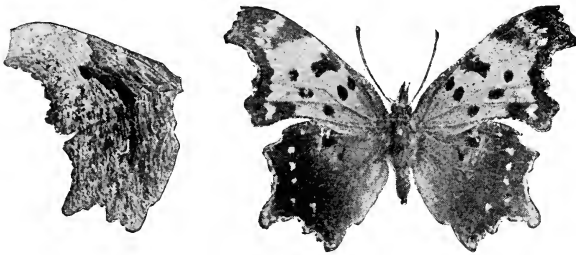

THE GRAY COMMA

Expanse about two inches. Color orange-red with black spots brownish borders to the wings. The under sides of the wings are "pepper and salt" arranged in wavy lines. The "initial" a delicate wide-angled L.

Its caterpillar attains the length of an inch and has a body yellowish-brown marked with greenish-black. It has many branched spines one pair being on the head. It feeds on currant, gooseberry, and elm.

#### THE SOVEREIGNS

These butterflies are noted for the very interesting habits of the caterpillar which are omitted here. The caterpillars when fully grown are so covered with humps that they look most grotesque. On the front end of the body is borne a pair of tiny tubercles that look like pompoms. The chrysalis has a projection which resembles a Roman nose.



THE WHITE ADMIRAL OR BANDED PURPLE  
 Expanse about three inches. Color velvety chocolate-black; the broad white band across the wings distinguishes it from other species.

THE RED-SPOTTED PURPLE  
 Expanse about three inches. Upper surface of wings velvety indigo-black tinged with blue or green iridescence. The border rows of spots on the hind wings a light iridescent blue. The wings on the undersides show many red spots.

*The Banded Purple or White Admiral.*—This beautiful and striking butterfly is quite local in its habits and spends its whole life near the same spot. It frequents shady roads. Its caterpillar feeds upon birch, poplar and shadbush.

*The Red-Spotted Purple.*—This is not so common in the North as the banded purple. There is a form which is hybrid between the two showing the trace of the

white band across the front wings, while the hind wings are usually like those of this species. Its caterpillar

feeds upon plum, thornapple and others.

*The Viceroy.*—This butterfly has forsaken the dark uniform of its family and has put on the dress of the monarch. This disguise affords it protection from the birds because the monarch is very distasteful to them, and they have learned to avoid all butterflies which look like it. The black band across the hind wings of the viceroy distinguishes it readily from the monarch. It is also a

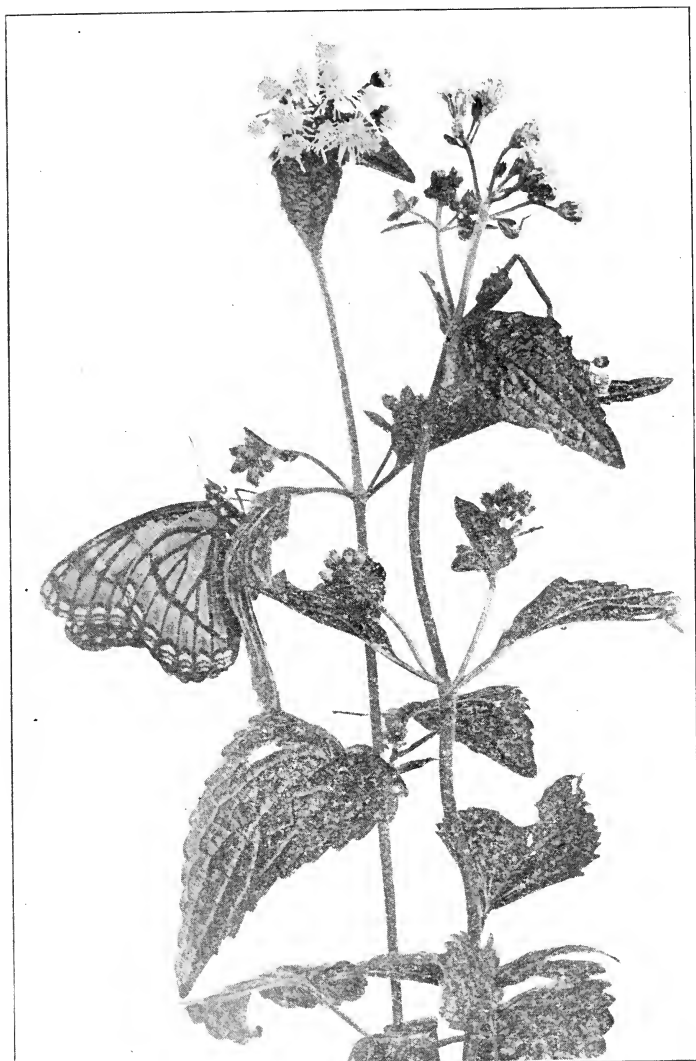

Photo by Dr. R. W. Shufeldt.

THE VICEROY

Wings orange bordered with black in which is a row of white spots.  
Veins black. Black band across hind wing

smaller butterfly. (See figure on page 237.) Its caterpillar feeds upon willow and poplar.

#### THE EMPERORS

*The Goat-Weed Emperor.*—This handsome orange red butterfly

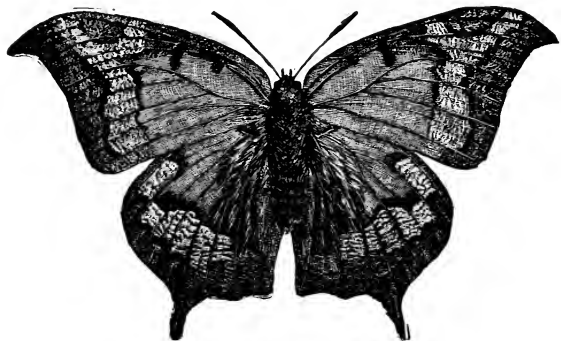

THE GOAT-WEED EMPEROR

The wings are bright-orange margined with brown with an irregular paler band just inside the brown margins.

and encrusted with little tubercles. It feeds upon goatweed.

can be distinguished from all others by the gracefully extended tips of the front wings and the equally striking points on the hind wings. It is a middle western and southern species. Its caterpillar is gray

#### THE MEADOW BROWNS

These are brown butterflies which do not attract much attention from the uninitiated, but are very much loved by any real student of butterflies.

*The Blue-eyed Grayling and the Dull eyed Grayling.*—These two species blend into each other, the blue-eyed being the southern form and the dull-eyed the northern form. The only difference between the two species is that the dull-eyed grayling lacks the broad yellow band on the front wings, but almost every grade between the two species may be found. The caterpillar attains the length of over one and one-third inches. It is green in

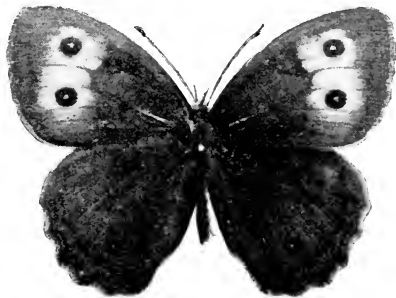

THE BLUE-EYED GRAYLING

Expanse two to two and one-half inches. Color dull brown with broad yellow bands crossing the front wings outside the middle. In this band are two black eye-spots, with little blue centers; small dark eye-spots on each hind wing.

color with yellowish stripes along each side. The body is covered with down, otherwise smooth. The rear end is forked. It feeds on grass.

*The Eyed-brown.*—This delicate fawn-colored butterfly repays well a little closer attention. Each velvety brown spot which ornaments the upper surface of the wings has a white center like a bull's eye on the lower surface. The caterpillar attains the length of one and one-fourth inches, is greenish in color and striped lengthwise. It is not only forked at the rear end, but has a pair of red horns at each end of the body; it hibernates when about

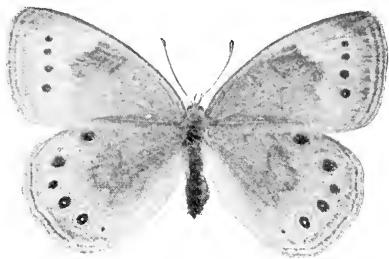

THE EYED-BROWN

Expanse about two inches. Color pale mouse-brown with a row of four velvety brown spots along the border of the front wing, and five or six smaller spots on the hind wing.

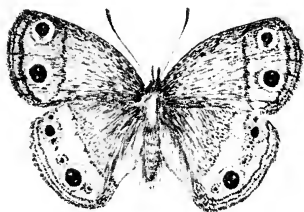

LITTLE WOOD SATYR

Wings nearly uniform dark brown. The small pupils of the eye-spots often double. Each eye-spot ringed with pale yellow.

half grown. It feeds on the coarser grasses and sedges.

*The Little Wood Satyr.*—This is a jolly little butterfly frequenting the shade of thickets and groves. It is single brooded and appears early in the season. The caterpillar is pale greenish brown and downy with blackish lengthwise stripes and it feeds upon grass.

## THE MILKWEED BUTTERFLIES

*The Monarch.*—This magnificent butterfly is a monarch indeed. The birds will not touch it and so it is afraid of nothing. Its flight is leisurely and extends over long distances. It does not winter with us, but comes to us each year from the South. In the fall it may be seen migrating back in flocks. Its caterpillar is banded crosswise with narrow black and yellow stripes. At either end of the body is a pair of whip-lash like organs; it attains the length of two inches. It feeds on milkweed; the chrysalis is plump and



A MONARCH CATERPILLAR

comparatively smooth, of an exquisite green color ornamented with dots of shining gold.

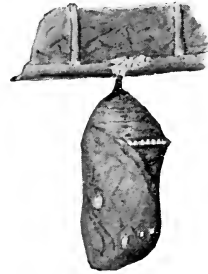

MONARCH CHRYSALIS

*The Queen.*— This is a Florida species. Its wings are chocolate brown bordered with black. The front wings are sprinkled with white dots inside the margins. The viceroy in Florida imitates the queen in color.

### THE LONG-BEAKS

These butterflies are easily distinguished by their long beak-like palpi which are from one-fourth to one-half as long as the body—only two species are found in the United States.

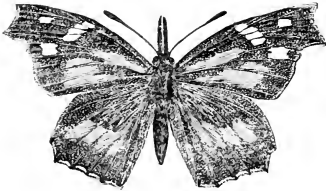

THE SNOOT-BUTTERFLY  
Blackish brown marked with orange patches and white spots.

*The Snout-butterfly.*—This little butterfly looks as if it had had its front wing tips snipped off with curved scissors. It sometimes occurs in swarms but is usually rather rare. It haunts river banks and marshy places. Its caterpillar feeds upon hackberry.

### THE GOSSAMER WINGS

These are our smallest butterflies, few of them measuring more than an inch across the expanded wings. They include the hair streaks, coppers and blues.

## THE HAIR STREAKS

These little butterflies are distinguished from others by the long tail-like prolongations of the hind wings. They are usually dark brown with delicate striped markings on the lower surface of the wings; some species are brilliantly marked with metallic blue or green. About fifty species occur in North America. A table for determining the common species is given in *How to Know the Butterflies* p. 217.

*The Gray Hair Streak.*—This frisky little brown butterfly has a bright orange-spot on the hind wings and one or two white tipped tails; it also has orange on the tip of its antennæ and its head. Its caterpillar is less than a half an inch long and slug-shaped, and is naked and reddish-brown. It feeds upon the fruit and seeds of hop, hawthorne, hound's tongue and St. John's wort.

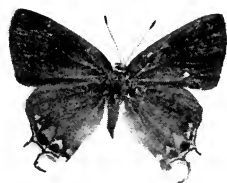

THE BANDED HAIR-STREAK

*The Banded Hair Streak.*—This is our commonest hair streak. It frequents openings in the woods especially scrub oak clearings; though dull in color it has on the inside at the tip of the hind wings a blue patch with an orange patch on each side of it. Its caterpillar is slug-shaped, half an inch long, grass-green in color and feeds on oak, hickory and butternut eating holes in the leaves; it winters as a newly-hatched caterpillar.

Expanse one and one-fifth inches. Color dark brown or blackish; lower side of the wings grayish with rows of black spots margined with white. Blue spot with orange spot on each side of it on the hind angle of the lower wing.

## THE COPPERS

These are distinguished from the other gossamer wings by their orange-red and brown colors.

*The Wanderer.*—This lovely little butterfly is usually found near alders. Its caterpillar is rather wide in the middle and pointed at each end, about one-half inch in length; its color is brown marked with brownish stripes. It differs from the caterpillars of other butterflies in that it is not vegetarian, but lives instead, upon the woolly plant-lice which infest the alder and thus is a very good friend to this tree.

*The American Copper.*—These jolly midglets flit about over lawns almost always playing with each other and sometimes even daring to play with us as we cross their path. The caterpillar is

slug-shaped, a half an inch long, dull rosy-red in color; it feeds on sorrel.



THE WANDERER

Expanse a little over an inch. Color dark brown with large irregular orange-yellow patch in the central part of the fore wing and a similar patch on the outer half of the hind wing.



THE AMERICAN COPPER

Expanse about an inch. Color of front wings red with black spots and borders; hind wings coppery-brown with broad orange-red band on the outer margins.

### THE BLUES

*The Spring Azure.*—This bit of a blue butterfly comes to us early in the spring and seems like a promise of blue skies and sunshine. Its caterpillar is two-fifths of an inch in length, slug-shaped, whitish



Male

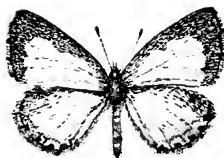

Female

THE SPRING AZURE

Expanse about an inch. Color blue with purplish tinge; wings bordered more or less with black.

with dark brown head. It lives on the flowers of dogwood, sumac, spirea and others. A remarkable thing about the caterpillar is that it bears an organ on the back which exudes honeydew; ants feed upon this and protect the caterpillar.

### THE SKIPPERS

There is a family of insects usually included with the butterflies called Skippers. These are usually small dark brown or dull yellow and may be distinguished from the butterflies by the fact that the antennæ are either hooked at the tips or bent at an angle. The character which distinguishes butterflies from moths most readily is that the butterflies always have antennæ which are enlarged at or toward the tips. Knobbed antennæ they are called; while the antennæ of moths may be straight and simple or feather-like. The



antennæ of the Skippers are enlarged like those of the butterflies

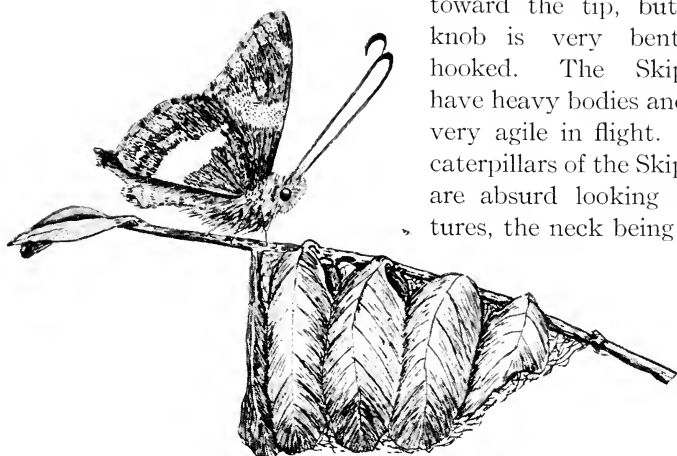

toward the tip, but the knob is very bent or hooked. The Skippers have heavy bodies and are very agile in flight. The caterpillars of the Skippers are absurd looking creatures, the neck being very

THE SILVER SPOTTED SKIPPER ABOVE THE NEST OF ITS CATERPILLAR  
Color chocolate brown—the front wings marked with yellow and the lower wings marked with white on under side. Its caterpillar forms a nest by fastening together the leaflets of locust leaves.

small and the head very large. They usually live concealed in a folded leaf or in a nest made of a few leaves fastened together.

There are about two hundred species of Skippers in America north of Mexico and they are very difficult to determine except in the case of some of the larger and well marked species. In one sub-family which are largely of tawny or orange brown color, there is an oblique dark patch across the front wing. To another sub-family belong most of the blackish or dark brown or dusky winged Skippers often dotted with white or lighter yellow and which have a little fold along near the front border of the front wing.

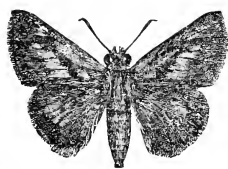

A male skipper with a diagonal "brand" across the front wings. Many of these are coppery yellow and brown in color.

The main thing for the beginner in the study of butterflies to achieve is to know a Skipper when he sees it and to be able to say at once, "this is a skipper and not a butterfly."

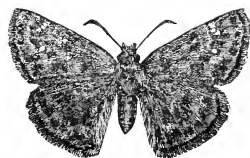

A male skipper with a fold near the front margin of the wing. Most of the species are dark brown marked with white or translucent angular spots.

## COLOR KEY TO THE COMMON BUTTERFLIES

Based upon a Laboratory Exercise in Nature-Study at Cornell University

By HELEN M. HESS

- A. Large butterflies—strikingly black and yellow. Hind wings with tails.
- B. Wings yellow, margined with black with four black bars across the front wing. Expanse  $3-3\frac{1}{2}$  in.  
*Tiger Swallowtail—Turnus form*
- BB. Wings black above, yellow beneath with broad diagonal band of yellow from tip of front wing across base of hind wing. A row of striking yellow sub-marginal spots across hind wings and merging into diagonal band on fore wing. Wing expanse 4-5 in. *Giant Swallowtail.*
- BBB. Wings black, with double row of yellow marginal spots on front wing, the inner row making a yellow band across the hind wing. Wing expanse  $2\frac{1}{2}-3$  in.  
*Black Swallowtail, male*
- AA. Butterflies mostly black. Wing expanse  $2-3\frac{1}{2}$  in.
- B. Hind wings with tails.
- C. Front wings black with pale spots near outer margin in single row and often rather inconspicuous.
- D. Hind wings with blue spots or green inside the outer row of yellow spots.
1. Often six crescent shaped spots along the outside of the hind wing. The lower and especially upper one orange. The others yellowish.  
*Tiger Swallowtail—Glaucus form.*
2. The pale marginal spots along outer margin of hind wing all the same color. An orange spot at the middle of front margin and two orange spots near inner angle of hind wing.  
*Green-clouded Swallowtail, female.*
- DD. The hind wings greenish and with only one orange spot at inner angle of hind wing.  
*Green-clouded Swallowtail, male.*
- DDD. Hind wings metallic dark blue. No orange spots on upper side. On the lower side the marginal row of spots orange below, pale above.  
*Blue Swallowtail.*

CC. Front wings with double row of yellow spots.

1. Hind wing with yellow band across the middle.  
*Black Swallowtail*, male.

2. Hind wing with a row of blue spots between the  
outer and inner row of yellow spots.  
*Black Swallowtail*, female.

BB. Hind wings without tails.

C. Wings with white markings.

1. With wide white band across the middle of both  
wings.

*Banded Purple or White Admiral*.

2. With band across only the front wings.

*The Hybrid Purple*.

3. Diagonal red band across front wings which are  
spotted with white near tips. Orange red  
border to hind wings.

*Red Admiral*.

4. Wings bordered with orange yellow spots and  
outer third checkered with cream white.  
Rather small.

*The Baltimore*.

5. Small blackish butterflies, peppered with white,  
with tips of antennae bent. Belong to the  
family of

*Skippers*.

CC. Wings with no white markings.

1. Hind wings with border of three rows of blue or  
greenish spots, and underneath a border of  
seven orange spots just within a double row of  
blue or green spots.

*The Red-spotted Purple*.

2. Wings with brownish tinge with broad border of  
pale yellow. Just inside the border a row of  
blue or purplish spots.

*The Mourning Cloak*.

AAA. Butterflies with general color of copper red or brick color.

B. Large, with wing expanse of  $2\frac{1}{2}$  to 4 inches.

C. Veins completely outlined with black.

1. With no transverse black band across hind wing.

*The Monarch*.

2. With transverse black band across hind wing.

*The Viceroy.*

- CC. Veins outlined with black near outer border. Large silvery spots on underside of hind wing.

*The Gulf Fritillary.*

- CCC. Veins not outlined in black. Wings coppery, checkered and spotted with black. Inner half of wings dark brown. No white markings.

- D. Under sides of hind wings with large silver spots.

1. A broad buff band inside the border of silver spots on lower side of hind wing.

*The Great Spangled Fritillary.*

2. A narrow buff band inside the outer row of silver spots on border of under surface of hind wing. The band not so wide as the silver spots in border.

*The Silver-spot Fritillary.*

- DD. Under side of the wings marbled in yellowish and browns.

*The Variegated Fritillary.*

- CCCC. Front wings coppery, checkered with black. Hind wings black with lighter spots. Very large butterfly. Expanse 4 inches. The front wings orange beneath, the hind wings olive brown with about thirty large silvery white spots.

*The Regal Fritillary.*

- CCCCC. Orange red with tips of front wings prolonged with curved points and with short tail on hind wing.

1. Narrow margin of brown borders the wings. A small dark spot in middle of margin of front wing.

*Goatweed Emperor, male.*

2. Broad border of brown with paler orange inside it, and brown spots inside this pale band.

*Goatweed Emperor, female.*

- CCCCCC. Copper red and black butterflies with tips of front wings blackish, spotted with white.

- D. Hind half of lower side of front wings rose color.

1. Lower side of hind wing showing two eye-spots within the border.

*The Painted Beauty.*

2. Lower side of hind wing showing four eye-spots within the border.

*The Cosmopolitan.*

DD. Copper red, diagonal band across front wings, which is vivid rose red below; red border to hind wing.

*Red Admiral.*

BB. Smallish copper red or copper yellow and black butterflies. Wing expanse from  $1\frac{1}{2}$  to  $1\frac{3}{4}$  inches.

C. Copper red checkered with black above. Edges of wings not notched.

1. Lower side of hind wing with silver spots.

*Silver-bordered Fritillary.*

2. Lower side of wings with no silver spots.

*Meadow Fritillary.*

CC. Orange with black border and many black irregular markings. Margin of wings not notched. Lower side of wings marbled with yellows and browns.

1. A distinct narrow yellow line bordering lower sides of wings.

*The Silver Crescent.*

2. No distinct yellow line bordering lower sides of wings.

*The Pearl Crescent.*

CCC. Copper red and black butterflies. The edges of the wings notched and under sides of wings marbled browns of different shades.

D. With a white "initial" at center of lower side of hind wing.

1. The initial of two silvery marks, a crescent white line and a dot. Wings above bordered with lavender

*The Violet Tip.*

2. The outer third of the lower surface of the wings variegated with olive green. The initial a C or a G.

*The Green Comma.*

3. Outer third of the lower surface of the wings variegated with wood brown. The initial also a C or a G

*The Hop Merchant.*

4. The marbled surface of the under side of the wings crossed by many fine ashen lines. The initial an L. *The Gray Comma.*

DD. With no initial on hind wings.

1. Wings blackish with a broad orange red band marking the outer half of both wings.  
*The American Tortoise Shell.*

BBB. Very small copper red or coppery yellow butterflies, not expanding over one inch.

1. Front wings copper red, spotted with black and outer margin blackish. Hind wings dark with bright copper outer border.

*American Copper.*

2. Front wings dark brown with large irregular orange yellow patch over the middle. The hind wings brown with orange yellow patch extending forward from hind margin. *The Wanderer.*

AAAA. White butterflies.

B. With front wings tipped with black.

1. With two spots on front wing.

*Cabbage Butterfly, female.*

2. With one spot on front wing.

*Cabbage Butterfly, male.*

3. With black blotch at middle of margin of front wing.

*Olympia Orange Tip.*

BB. With front wings prolonged at tip to a hook.

1. Wings tipped with orange.

*Falcate Orange Tip, male.*

2. Front wings bordered with delicate black spots.

*Falcate Orange Tip, female.*

AAAAA. Butterflies conspicuously yellow.

B. With tails to the hind wings.

1. Large, with black border and four black bars extending back from front margin of front wing.

*Tiger Swallowtail, Turanus form.*

BB. Hind wings without tails. Expanse 2 inches or less.

C. With black border on outer margin of wings.

D. Lemon yellow.

1. With outer black border unbroken.

*Roadside male.*

2. With black border on front wing broken with yellow spots. *Roadside female.*
3. With deep black border outlining the profile of a head, and with black base to front wing. *The Dog's Head.*
4. With outer border unbroken. A small butterfly only one inch in expanse. *Little Sulphur.*

DD. Orange yellow butterflies.

1. The black border unbroken and with oval spot at center of front wing near margin. *Orange Sulphur.*
2. Black border unbroken in male but fading out on the hind portion of the hind wings in the female. Spot at middle of front wing, near margin a mere line. *The Sleepy Yellow.*

CC. Lemon yellow with no solid black border. Large butterfly  $2\frac{1}{2}$  inches in expanse.

1. With black spots bordering the wings and with round spot at the front middle of front wing. *Cloudless Sulphur, female.*
2. With no black spots of any kind, just pure yellow. *Cloudless Sulphur, male.*

AAAAAA. Butterflies conspicuously brown or gray.

B. Rather large with an expanse of 2 to  $2\frac{1}{4}$  inches, with no tails on hind wings.

C. With one large eye-spot and one very small one on front wings, and with one large and one small eye-spot on hind wings.

1. Diagonal band of yellow across tips of front wing and two copper red bars extending back from the margin of front wing. Copper red near margin of hind wing.

*The Buckeye.*

CC. With two equal sized eye-spots on front wings. Expanse 2 inches.

1. With the eye spots on the front wing set in a band of yellow.

*The Blue Eyed Grayling.*

2. With no band of yellow surrounding eye-spots on front wing.

*Dull Eyed Grayling.*

3. The eye-spots on front wing each surrounded by yellow ring or set in yellow patch.

*Hybrid Grayling.*

- CCC. With two equal spots on front wing. Expanse  $1\frac{1}{2}$  inches. With two eye-spots on hind wings and sometimes a smaller one.

*Little Wood Satyr.*

- CCCC. With four small eye-spots in a row on front wings. With five small eye-spots along margin of hind wing.

*The Eyed Brown.*

- BB. Small butterflies with thread-like tails or with short projections on hind wings.

*The Hair Streaks.*

- BBB. Small butterflies without projections on hind wings. With rather heavy bodies and antennæ bent at the tip.

*The Skippers.*

- AAAAAAA. Butterflies blue or marked conspicuously with blue.

- B. Small butterflies mostly blue.

- C. Without tails to hind wings.

1. Lower sides of wings pale ash gray. Expanse about one inch.

*The Spring Azure.*

- CC. With tail-like prolongation to hind wings.

*Hair Streaks.*

- BB. Large black butterflies without tails to hind wings, marked with double row of blue spots near border of hind wings.

*The Banded Purple.*

- BBB. Large butterflies with tails to hind wings.

1. Black butterflies, shewn on hind wings blue or greenish blue.

*Blue Swallowtail.*

*Green-clouded Swallowtail.*

2. Black butterflies with blue spots on hind wings.

*Glaucus form of Tiger Swallowtail.*

*Black Swallowtail, female.*

- BBBB. Black butterfly with slight tail like prolongation on hind wings. With yellow border and row of blue spots inside of it.

*Mourning Cloak.*



Check list of Fifty Common Butterflies	Swallowtails	Tiger		
		Black		
		Zebra		
		Giant		
		Green-clouded		
	Pierids	Blue		
		Whites	{	Cabbage
		Orange tips	{	Falcate
		Yellows	{	Roadside
			{	Sleepy Yellow
			{	Dog's Head
			{	Little Sulphur
			{	Orange Sulphur
			{	Cloudless Sulphur
		Nymphs	Great Spangled	{
{	Regal			
{	Gulf			
Fritillaries	{		Variegated	
	{		Meadow	
	{		Silver-bordered	
	{		Pearl	
	{		Silver	
Crescent Spots	{		Baltimore	
	{		Mourning Cloak	
	{		American Tortoise	
Angle- wings	Compton Tortoise		{	Buckeye
			{	Thistle
	Butterflies		{	Red Admiral
			{	Painted Beauty
		{	Cosmopolite	
	Polygons	{	Violet Tip	
		{	Hop Merchant	
{		Gray Comma		
{		Green Comma		
Sovereigns	{	Banded purple		
	{	Hybrid purple		
	{	Red-Spotted purple		
	{	Viceroy		
	{	Goatweed Emperor		
Emperors				
	Meadow Browns	{	Blue-eyed Grayling	
		{	Dull-eyed Grayling	
		{	Eyed Brown	
{		Little Wood Satyr		
The Milkweed	{	Monarch		
	{	Queen		
Long Beaks	{	The Snout Butterfly		
The Gossamer Wings	Hair Streaks	{	Gray Hair Streak	
		{	Banded Hair Streak	
	Coppers	{	Wanderer	
		{	American Copper	
	Blues	{	Spring Azure	

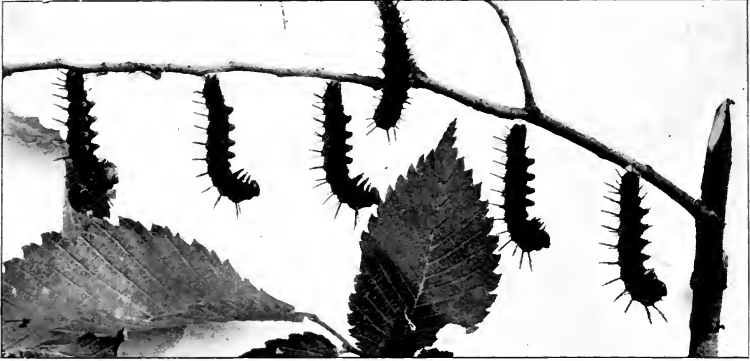

The Mourning Cloak caterpillars are sociable even when changing to chrysalids

## Some Disguises of the Mourning-cloak

HARRIET A. WICKWIRE

Cortland, N. Y.

May in the woods! Hepaticas bursting into bloom; blue and white violets down among the coiled ferns and dried leaves of last fall; and, last but not least, a great dusky winged butterfly, dancing entrancingly through the shadows and sunlight.

Who has not seen it? Every one has been startled by the appearance of this big purple-brown butterfly, bordered with straw color, and having a row of violet-blue spots around the wings. However, few of his many admirers really know the Mourning-cloak in all his phases of existence.

He starts life as a tiny melon shaped egg, first pale amber, then changes through tan to rose and finally becomes blue-gray before the minute crawler emerges. The egg period lasts about ten days, and as the eggs are laid in close mats the caterpillars emerge together; they eat together and live together also.

For the first three days the baby crawlers are yellow, with black heads and have a very greasy appearance. They form a nest of silk, soon after emerging from the eggs, and eat young willow leaves ravenously, growing to be a quarter of an inch long in four days.

On the fifth day, the brood prepared to molt, the new heads could be seen growing just back of the old ones and were black. Two days later the molt took place, and the crawlers gained black spines.

Another four days and the second molt took place. The head and body were both black this time, and there were longitudinal tan stripes running the length of the caterpillars. The spines were black, and those nearest the head were the longer. The first three pairs of legs, (the true feet) were black, while the others (prop feet) were tan colored.

Three days and then another skin was cast. The new head was large, round and black, just back of it was a crest of small black spines. The body was black with a row of red spots down the back each side of which were the large black spines; the smaller spines on the sides of the caterpillars were grayish. The true feet and the last pair of prop feet were black, the other prop feet being reddish tan.

Four days more and the last molt took place. There was no change in the colors this time, but the crawlers grew to be one and a half inches in length. They still lived together and when someone beat on a tin pan near them they would throw themselves from side to side in a most comical manner, for all the world like a company of Shakers.

It was twelve days after this last molt that we found the first chrysalis, and a queer little body it was! Suspended by the tail it hung from a twig, plump in shape and purple brown in color with little gilt knobs for ornaments, surely a fit covering for any fairy to burst from.

After a sleep of thirteen days, a quivering at the end of a chrysalis warned us of the coming emergence. When at last the crumpled wet winged insect struggled through the tiny opening, it seemed impossible that this creature could ever become the dusky nymph of the May woods; but after half an hour of fanning the queer little dwarfed appendages which appeared where the wings should be, shook out, perfect in form and exquisite in coloring. Then with a whiff of the summer breeze our captive was off; sailing down the golden sunbeams and dancing with the woodland shadows.



Spice-bush Swallow-tail (*Papilio troilus*); male. (Nat. size on negative). The vine is the Bindweed, and the flowers are of the Butterfly Milkweed.

## Some Familiar Butterflies

By Dr. R. W. SHUFELDT, C.M.Z.S.  
Washington, D. C.

Sometimes it almost seems as though the interest taken in the different departments of the study of living forms in nature, as well as in the various divisions of botany, were passed along in waves by those interested in them or engaged upon their study and literature. In illustration of this, an unusual amount of attention has been paid, within the past few years, to butterflies and moths, both by scientific workers and by amateur naturalists in many parts of the country. Some very good works have appeared on the subject, especially such epoch-making volumes as Doctor Holland's two books—one on our butterflies and the other on the moths of this country. Several enterprising collectors of these insects have recognized the commercial side of this widespread interest, and have built up establishments entirely given over to the purchase of our moths and butterflies in unlimited numbers, for the purpose of supplying museums, private collectors, and "the trade" generally.

The present article has nothing to do with this aspect of butterfly study, however commendable such work may be; on the other hand, it will simply invite attention to a few of our best known species, with the hope that it may induce the young naturalist and reader of NATURE-STUDY REVIEW to widen the field of his studies along this line, and to add material to his or her collection for comparative study.

Perhaps one of the best known groups of butterflies in this country—certainly one of the most numerous—are the forms assembled in the subfamily *Pierinæ*, that is, the "Sulphurs" and the "Whites." This subfamily is contained in the family *Papilionidæ*, or the Swallowtails and their near relatives—a group to which reference will be made further on.

As a general thing, the Sulphurs and the Whites are medium-sized forms, and often quite small species. These have the upper as well as the under sides of the wings yellow—a Naples yellow—bordered above with black; there is generally a small spot near the middle of any one of the wings. The bodies are dark, nearly black, and more or less densely covered with a pale yellowish down. The most common representative is the Common Sulphur, different individuals of which present considerable variation, and

the great number of species in this genus, as well as in others of the subfamily, is really remarkable. With but few exceptions, this is the case throughout the group. For example, in the tropical genus *Dismorpha* there are over one hundred species, and perhaps fully that many more yet unknown to science. In another genus (*Tachyris*), nearly eighty species belong in the Old World, while only one is found in this country, and in it the sexes are quite different in their color-pattern. Those of another genus have been called the "Whites;" they are of medium size, generally white in color, with certain limited marginal markings, and, in one species at least, conspicuous spots.

The species generally known as *the* Cabbage Butterfly belongs to this genus *Pieris*, it being *Pieris rapæ*. Writing about it in his "Butterfly Book," Holland says: "This common species, which is a recent importation from Europe, scarcely needs any description. It is familiar to every one. The story of its introduction and the way it has spread over the continent has been well told by Dr. Scudder in his second volume of 'The Butterflies of New England' (p. 1175). The insect reached Quebec about 1860. How it came no man knows; perhaps in a lot of cabbages imported from abroad; maybe a fertile female was brought over as a stowaway. At all events it came. Estimates show that a single female of this species might be the progenitor in a few generations of millions. In 1863 the butterfly was already common about Quebec, and was spreading rapidly. By the year 1881 it had spread over the eastern half of the continent, the advancing line of colonization reaching from Hudson Bay to southern Texas. In 1886 it reached Denver, as in 1884 it had reached the head waters of the Missouri, and it now possesses the cabbage fields from the Atlantic to the Pacific, to the incalculable damage of all who provide the raw material for sauerkraut. The injury annually done by the caterpillar is estimated to amount to hundreds of thousands of dollars." (p. 280).

Again, some of the species of the subfamily are very small, some being white upon their fore wings, tipped with bright orange with black-spotted emarginations (*Euchloë*). Passing these and many others, we meet with the genera *Catopsilia* and *Kricogonia*, created to contain the "Great Sulphurs," which are very much larger species, of a brilliant orange or yellow color and few markings. The Cloudless Sulphur (*Catopsilia cubule*) is of a rich yellow color, and measures some two and a half inches across. It is an insect of

very vigorous flight; I have never taken it but once in my life, and then with a very stiff straw hat on the shore of Chesapeake Bay in the State of Maryland.

A good, big volume might easily be written on this group of butterflies, and to fully illustrate it, hundreds upon hundreds of colored cuts would be required. So I leave them, to pass on to their near relatives of the subfamily *Papilioninae*—another enormous assemblage of insects. These are usually large species, with either one of the posterior pair of wings produced into an elongate, narrow projection, which some describers have likened to a “tail;” hence, the name of Swallow-tail Butterflies. Most of the first section, or the *Parnassians*, are western species, and some of them are of marked beauty, as *P. smintheus* for example, found from Colorado to California, and from New Mexico to Montana. The male has an expanse of some two and a half inches, and the female is still larger. It is an extremely variable species with respect to color and markings—indeed, to such an extent that Holland devoted no fewer than six colored figures to it, in that these variations might be exhibited. Variety *P. hermodur* is an especially beautiful insect, it being of an ash gray, with black and deep orange spots on the upper sides of the fore wings, and large orange spots, margined with black, on the hinder pair. There are many species of *Parnassius* in this group, and they are, for the most part, insects of a pale, dusky white color, set off by various small spots, bands, and emarginations of dusky gray, black, and yellowish orange.

An abundant butterfly in the District of Columbia, especially in the valley of the Potomac River, is the *Ajax*—the *Papilio ajax* of science—and its summer form of *P. a. marcellus*. An upper view of *Ajax* is shown on the cover, it being a reproduction of a photograph I made of one I captured at Great Falls, Maryland. Note the extraordinary length of the “tails” to its hinder pair of wings, and the elegant pattern of both pairs. There are several *winter* forms of *Ajax*, as *P. a. walshi*, *P. a. telamonides*, and *P. a. floridensis*, all of which have arisen from the note-worthy variations in the markings of the insect, which are more or less constant. *Ajax* feeds on the leaves of the papaw; many of these trees are found in the environs of Washington, and where they occur in the river bottom, one is sure to meet with this particular Swallow-tail flitting gracefully up and down the roads and paths through the woods and marshes. According to Holland, *Ajax* “ranges from



Two Monarch Butterflies (*Anosia plexippus*) on Goldenrod;  
nat. size on negative. Collected in Maryland by the author.



southern New England, where it is very rare, west and south, over the entire country to the foot-hills of the Rocky Mountains. It is very common in the lower Appalachian region, and in southern Ohio, Indian, Kentucky, and Tennessee is especially abundant."

The big "Tiger Swallow-tail" (*Papilio turnus*), the brilliant yellow butterfly, so conspicuously marked with black, is too well known to require either description or a figure; it has been locally called the "lordly Turnus." There is a black form of the female which occurs in the southern part of its range, and which was, for a long time, regarded as a distinct species. There is also, in Sitka, a small, yellow, dwarf form, and specimens of this are to be found in private and museum collections.

A much handsomer and very much larger butterfly than the Tiger Swallow-tail is the Daunus (*P. daunus*), which is found in many parts of the Rocky Mountains, being especially abundant in certain parts of Arizona. It closely resembles in general appearance *P. turnus*, but may at once be recognized by its larger size and the fact that it has *two* "tails" on either posterior wing—an outer long one and a shorter inner one—instead of the single one on either wing as in *Turnus*. In the small *P. pilumnus*, there are *three* "tails" on either side, which gives this butterfly a very elegant appearance. It is a Mexican species (feeding on laurel leaves in its early stages), but has been taken in Arizona.

The list of our Swallow-tails and their near allies is a long one, and it will be quite out of the question to even mention them all by name here; but I cannot finish with them without at least calling attention to the familiar black one, here shown on page 254, which is a male of this species (*P. troilus*). Besides occurring throughout the Atlantic States, this handsome butterfly is to be found in certain localities down the Mississippi River. I recall having taken it once or twice in the environs of New Orleans, while I have captured scores of specimens of it in the New England and Middle States, where also occurs the beautiful "Pipe-vine Swallow-tail" (*P. philenor*).

Fine specimens of the Monarch butterfly are here shown on page 258, they being a pair I captured upon some Goldenrod at Bradley Hills, (Edgemoor), Maryland, a number of years ago. This species is the *Anosia plexippus* of science, and is so well known as not to require any special description. Its general color is of a lively reddish, set off with black markings and venations. Rows of

chalky white spots, as shown in my illustration, on the body and wings greatly enhance its general beauty. The males have a black scent pouch on the first median nervule of the posterior pair of wings, and this species seems to produce numerous broods every year.

The Monarch is a migratory species with a most interesting history, and is now spreading over a large part of the world. Holland remarks that "this insect sometimes appears in great swarms on the eastern and southern coasts of New Jersey in late autumn. The swarms pressing southward are arrested by the ocean. The writer has seen stunted trees on the New Jersey coast in the middle of October, when the foliage has already fallen, so completely covered with clinging masses of these butterflies as to present the appearance of trees in full leaf" (pp. 82, 83). Of this genus our butterfly fauna also contains "The Queen" (*A. berenice*) and *A. strigosa*.

There is another very interesting genus of butterflies known as the "Checker-spots" (*Melitæa*), and a year or so ago I collected the Baltimore (*M. phaëton*) near Washington. Above, it is of a deep black, with rows of red spots and several rows of yellow spots on the fore and hind wings. It is an exquisite little representative of our butterfly world, and may be found in restricted localities in swampy areas where the *Chelone glabra*, or Turtlehead, grows, upon which it feeds. Its range is northeastern United States into Canada and southward to the Virginias.

### TO OUR SUBSCRIBERS

Please note your expiration date and send in your renewals promptly.

Owing to the increased cost of paper and printing, also to the fact that The Nature-Study Review has not raised its subscription price, we will print only enough magazines each month to cover the subscription list and its normal increase.

A blue check on this space indicates that your subscription expires with this number.

## The Chrysopas or Golden Eyes

ROGER C. SMITH, Ph.D.

Public Museum, Milwaukee

This family of common insects is one deserving our acquaintance. Not only are they beautiful and possess striking habits, but they are also of considerable economic importance. Both the larvæ and adults feed on plant lice, young scale, mites and other small, soft-bodied forms which are for the most part destructive to man.

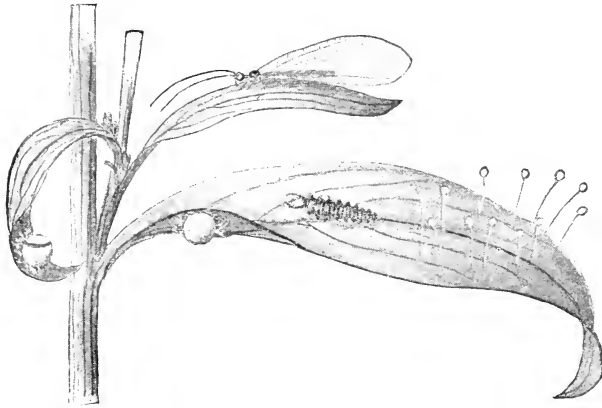

The adults of this family can be taken at lights in the evening from seven to nine o'clock and around plants upon which are plant lice or aphids from early summer until late autumn. The stalked eggs, all stages of the larvæ and occasionally the cocoons can be found on aphid infested plants during the same period. The adults are largely pale green in color with the head variously marked with orange, red or brownish black. The eyes in life have a striking golden luster, hence the name golden eyes (chryso-golden, ophis-eye). The wings are large and when at rest are held roof like at the sides of the body. They are opalescent and their rich venation has called forth the name "Lace Wings" for the family, a name quite commonly used. The wings vary slightly in size, shape and coloration. The veins of some species are all light green others vary to all veins black. There has been some difference of opinion as to the food of the adults. But the writer believes that practically all our species eat aphids, requiring 10 to 20 per day. They also lap up drops of water or plant sap greedily.

The writer especially recommends these insects for school room study and demonstrations. They are very easy to rear and have some exceptionally interesting habits. The adults should be placed in small vials, 4 oz. being desirable. Leaves with plant lice on them should be put into the vials daily for food. Females with greatly distended abdomens may be expected to oviposit very soon. By a little close observation, one may see the process of oviposition. The light green, elongate, oval egg rests on a comparatively long, clear stalk. Oviposition may continue for six weeks. When ten or more eggs have been desposited in one vial, the adult should be removed to another vial. The eggs should be closely watched as the little embryo may be observed in the eggs after the second day. They are outlined in red or reddish brown. After the fifth day, the eggs may be expected to hatch.

There is a specialized structure called an egg burster that enables the hatching process to take place. In eggs ready to hatch, it will be seen as a short dark line on the ventral side between the eyes. If an egg be taken from a group where most are already hatched, the operation of this device may be observed under a microscope. After hatching, it will be found, adhering to the cast off embryonic molt in the opening of the egg shell. This may be mounted in balsam or glycerine jelly and studied.

The hatched larvæ rest for a time on the egg shell but as they grow hungry, they become restless and finally come down the stalk. Immediately they go in search of plant lice or any soft-bodied small insects, not excepting young larvæ of their own kind, which they pierce with their two sickle shaped jaws which are curved tubes and suck out the body fluids. Under a microscope, one can see the juices running up the jaws and sometimes the contraction and expansion of the pharynx which constitutes the sucking pump. The larvæ must be fed daily with 20 or more small plant lice. Because of their ravages among aphid colonies, the larvæ have been given the very appropriate name of "Aphis Lions."

On about the third day after hatching or a little later, each larva will shed its skin. One can readily ascertain when a larva will molt by the peculiar glassy appearance of the body wall and by the way the black setae are folded across the back just underneath the old skin. The larva, when ready to molt, glues the tail fast to the glass and then by a series of movements, pulls the body loose from the old skin. Then the body is shifted forward and this causes the

old skin to burst over the thorax. A very clean appearing larva with a clean-cut color pattern emerges and in about an hour the body wall will be hard enough that the larva can walk around and attack plant lice. Before the larva is grown, it will molt again four or five days after the first molt.

A number of very interesting observations and experiments can be made with the larvæ. For example, while a nearly grown larva is eating an aphid, the bottle may be turned so that the larva is uppermost, its feet may be then lifted from the glass and the larva forced to hang suspended by the tail. The tail is actually glued to the glass in this case and when the larva walks about, the gelatinous secretion may be readily seen with the aid of a microscope. If a nearly grown larva be starved a day or two, the food getting instincts and reactions may be studied. It searches everywhere for plant lice with its long jaws and an empty aphid skin is attached just as an aphid would be but it is soon thrown aside. If an aphid be held by a pair of tweezers in front of the larva, it will not see it. If the antennæ jaws or any of the body setæ be touched, the larva gives evidence at once of having detected its presence. It may grab the aphid before one can get it away.

Tactile sensations are therefore the most important in food getting. Many other experiments such as using different insects for food, various prepared foods as beef tea, veal syrup, light and dark experiments, forcing a larva to defend itself, placing two hungry larvæ together to see the combat and allowing a hungry larva to attempt to puncture your finger may be carried out with interesting results. A little patience is required as not all larvæ perform just as one would like.

The spinning of the cocoon when the larva is grown is one of the most interesting things in connection with the study. It requires twenty-four to forty-eight hours to complete the little oval, white silken cocoon. If a larva has started to spin and is not very far advanced, it may be removed to a glass slide, a rubber or glass ring placed over it and a cover glass on top so that it is confined for observation under a microscope. In this way the very start of the spinning may be observed. The larva lies on its back and the tail moves rapidly here and there fastening the silken thread around it building first a sort of frame work. The larva shifts at regular intervals so that the cocoon is of uniform thickness. The long setæ on the body are broken off with each shift and these go into

the construction of the cocoon like the ribs of a basket. Watch the weaving pattern. It changes gradually as the spinning progresses. For a little amusement force the larva when nearly spun up to defend itself. It may plunge its jaws through the cocoon and attack a pair of tweezers fiercely. Or tear the cocoon and watch the larva carefully mend it so that the tear can scarcely be found. The cocoon when completed is about the size of a pea and, as many writers have remarked, appears to be about half the size of the original larva though it is now contained within it.

Within this cocoon, the larva transforms to the pupa, the resting stage before that of the adult. One can follow the changes by the external appearance of the cocoon. The black disc at the lower end of the cocoon indicates that the larva has molted and now there is a pupa within. As the pupa matures, a distinct greenish tinge can often be seen in the cocoon and sometimes the dark eyes of the adult are evident.

Finally after about two weeks, the pupa pushes off a circular lid at the upper end of the cocoon and emerges. This lid by the way, is the result of certain weaving of the larva while spinning and is not cut by the heavy pupal mandibles. The pupa in this case is the adult with a transparent skin over it. The pupa immediately seeks to climb and if it be placed on a potted plant, it will climb rapidly up a stalk, take up a position at the top with the head upwards and then begin a series of expansions which are calculated to burst the pupal skin and free the adult. After ten or fifteen minutes of expansion the body will be shifted forwards and this bursts the skin over the thorax. The adult slowly emerges, then takes up a position again with head uppermost to allow the wings to expand. These expand by blood pressure, the tip being the last to flatten out. Immediately after the wings are expanded, the adult voids a large lump of excrement which one can see as a black area near the end of the abdomen. This is the excrement stored up by the larva through its whole life as the intestine of the larva does not extend entirely through the larva so it can not be voided.

The adult will now attach plant lice and eat three to a dozen at a time. The light green coloration of the adult is a very good example of protective coloration. This color very closely matches that of the leaves among which it rests during the larger part of the day. The adults have an important means of defense. When they are disturbed or squeezed between the fingers, they emit a

very disagreeable odor which has unusual lasting qualities. This odor is only partially effective as birds and some insects will eat them in spite of it.

This then is a very brief sketch of the life history of these beneficial insects and a few suggestions as to their study. As a source of study and observation they are extremely interesting and illustrate many characteristics of insect life admirably.



## A Clean Furrow

JAMES G. NEEDHAM

Seed-time, and open fields,  
And plodding team, and steady-cleaving share!  
To lay the earth in furrows, line on line,  
This is my care.

For lo, this waiting soil,  
Receptive, and responsive to my will,  
For all the ills of all the ages gone  
Is fertile still.

So soft! no roar of arms;  
But gentle crumbling of the mellow earth;  
Yet each sustaining harvest still has here  
Its place of birth.

I'll guide my sturdy plow  
And turn the ribboned furrows, line on line;  
For tho the world has many things to do  
This task is mine.

And when my day is done  
And evening's glow has settled o'er the scene,  
Returning from the field I'll leave behind  
A furrow, clean.

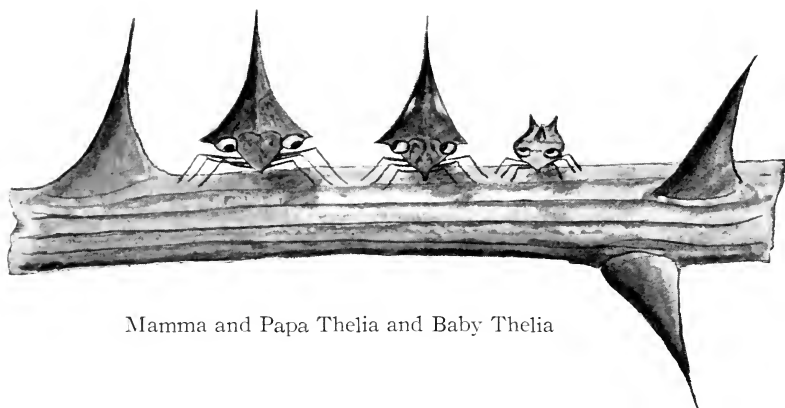

Mamma and Papa Thelia and Baby Thelia

## A Funny Family

WILLIAM D. FUNKHAUSER

Principal of Cascadilla School, Ithaca, N. Y.

Mr. and Mrs. Thelia and their interesting family live on the thorny branches of a locust tree.

Mr. Thelia wears a gay yellow and brown striped waistcoat and a funny pointed cap rests jauntily upon his head. His eyes are like little black beads that look roguishly out from beneath his strange head-gear.

Mrs. Thelia, who is more sober than her lively partner, dresses in Quaker gray. She too wears a pointed cap although it is not so graceful as that of her dashing husband.

The Thelia children are dressed like their mother in dull gray garments. They are clumsy little fellows who stick fast to the gray bark of the tree and look as if they grew there. They seem to be covered with little spines or warts and this, together with their pointed tails, makes them look like tiny alligators.

The Thelias like to live upon the locust tree because its sharp thorns are just the size and color of their caps. This affords them protection from their enemies who do not consider thorns at all appetizing.

When Mr. and Mrs. Thelia are absent from home they leave their babies in the best of hands. Their nurse-maids are the great black ants that live at the foot of the locust tree. These ants are very devoted to their charges and never permit them to stray out of their sight.

Each baby has ever so many nurses all his own and it is very amusing to see them stroking the little fellows with their long



antennæ. They know that if the baby is stroked ever so gently he will give off a very sweet liquid called honey-dew. The ants are extremely fond of this kind of candy and do not cease to tickle the little fellow until their sweet tooth is satisfied. It is a great comfort to Papa and Mamma Thelia to know that on their return home they will find each child just where they left him, attentively guarded by his neat black-dressed nurses.

This summer on many locust trees there will be families of Thelias, grotesque, interesting and amusing, and there is much enjoyment to be had from watching these curious little bugs in their leafy home. The ants will betray to every sharp-eyed boy or girl the place where the babies are hidden, but woe to the fingers that try to steal them from their watchful guardians. Try it some time if you do not believe this story to be true.

The Thelias have many families of cousins, most of whom wear the same kind of droll little caps while others have queer humps upon their backs. One of the prettiest is Ceresa. She is pale green in color and shaped very much like a hazelnut. Some of their distant relatives who live in warmer countries are still stranger looking. Their caps are fantastic in shape and brilliant in color, resembling nothing so much as the bright toboggan caps of little boys and girls. Compared with them, the Thelias are plain little country cousins.

---

### ANNOUNCEMENTS

Reprints of Mrs. Anna Botsford Comstock's *Butterfly* article can be purchased. This article is valuable as an outline for teaching and has been in use for years at Cornell University. Price, Single copy 25c. 10 Copies up, 15c each.

---

Outline *Butterfly Plates* on paper suitable for coloring with crayons or water-color will be issued soon. These plates will be similar to the popular *Bird Plates* published by The Comstock Publishing Company. Watch for its publication date.

# THE NATURE-STUDY REVIEW

DEVOTED PRIMARILY TO ALL SCIENTIFIC STUDIES OF NATURE IN  
ELEMENTARY SCHOOLS

Published monthly, except June, July and August. Subscription price, including membership in the American Nature Study Society, \$1.00 per year (nine issues). Canadian postage, 10 cents extra; foreign postage, 25 cents extra.

**Important** Please note date of expiration of your subscription on the label of the wrapper. Subscriptions must be paid in advance to comply with postal requirements. Subscriptions and advertisements should be sent to *The Comstock Publishing Co., Ithaca, N. N.* Manuscripts for Publication and Books to be Revised should be sent to the Editor.

---

## Editorial

### Peaceful Invasions

If the ambitious and overbearing nations of the world would only take to nature-study instead of to guns and consider carefully the ways of weeds and butterflies they could learn how to make bloodless invasions that would succeed beyond any ever made by the means of war. The history of the cabbage butterfly reveals tactics that might well, if followed, make true the dreams of world empire. However, there is one stumbling block at the outset—and that is these peaceful and successful invaders are ideal pacifists in that they are world citizens and owe fealty to no mere individual nation. Any place on the twirling ball we call the earth where they can find a climate with which they can cope and their chosen nourishment in abundance, has their fullest allegiance.

“The pedigree of honey does not concern the bee.

A clover, any time, to him is aristocracy.”

Thus sang Emily Dickinson with perfect understanding of bee standards, and this merging of one's “own country” into a world wide range has its selfish as well as its socialistic advantages.

It was in 1860 that a little white butterfly arrived at Quebec from Europe as a stowaway on some transatlantic freighter which probably refused to carry passengers at any price; and it was in 1868 that another fragile white butterfly stole her passage and made her entry in the port of New York. She did not stop for inspection at Ellis Island but on leisurely wing made her way to

some suburban village of the great city where to her delight she found a garden with a cabbage growing in it. These two butterflies through accepting conditions as they found them and making the best of things went to work with a will to lay eggs and thus colonize the new world with their progeny. These were small beginnings but scarcely a quarter of a century had elapsed, before the descendants of these stowaways had captured and called their own every cabbage patch from the Atlantic to the Pacific and from the Gulf of Mexico to Hudson Bay and not a shot had been fired.

America once had some cabbage butterflies of her own which had fed on wild cruciferous plants for peaceful eons before Columbus discovered their country. When civilization came and brought fields of cabbage—these native aboriginal butterflies found this new food plant to their taste and came out of the wilderness and lived in gardens. But there was a certain consideration and delicacy in their depredations for they fed only on the outside leaves of cabbage leaving the solid head of this stimulating and odoriferous vegetable for the nourishment and delectation of the rightful owners. No such regard for the rights of man characterized the European invaders whose caterpillars dug and still dig their peaceful but odious trenches through and through the cabbage heads that belong to the rightful occupants of the country.

There is a vast, unwritten, unrecorded history of what happened to our polite native cabbage butterflies when these hordes of silent unmilitary invaders appeared. Did they intermarry with them and thus become absorbed in the dominant race? Or did they flee to the woods and to the wild crucifers of their ancestors—now covering less area because of cultivation and there silently starve and then become blotted out? No one knows! All that we do know is that while formerly the “checkered white” and “gray veined white” butterflies were common they are now seen but rarely. Meanwhile no country ever conquered and overrun by Roman Legions was ever more in the grip of the talons of the Roman Eagles than is North America to-day in the grip of the six tiny claws of this butterfly invader, *Pieris rapæ*.

## Teacher's Corner

The study of the butterfly should, to be ideal, begin with the egg. These eggs are often exquisite in color and markings, and are always laid upon the chosen food plant of her species. From this egg hatches a little caterpillar that should be studied and fed and cared for until it changes to a chrysalis, and the chrysalis to a butterfly. A breeding cage may be made by placing a bottle of water in which the stems of the food plant may be placed in a cardboard box, one side of which is covered with mosquito netting, or in a terrarium, or the bottle may be placed in a flower pot of earth and over it may be put a lamp or lantern chimney with a bit of mosquito netting over the top. Fresh food must be supplied as often as needed. No story of Cinderella with her magical change of costume is more interesting or wonderful than the changes of dress the insect takes on from egg to winged state. Caterpillars have a most engaging way of growing by shedding their skins every time they become too small, and each change of skin is likely to make a change in the color. The diary of the caterpillar should be written by the pupils. It may be written in the first person to make it seem more like a story.

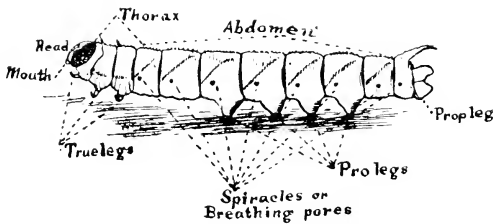

The Make up of a Caterpillar

### OUTLINE FOR STUDYING THE LIFE STORY OF A BUTTERFLY

Describe the caterpillar as follows: What is its shape? What is its ground color? Is it striped? Crosswise or lengthwise? Colors of stripes? Is it spotted? Has it spines or tubercles? If so, on what segments?

How do the front three pairs of legs look? How do they compare with the prolegs? How many prop-legs are there? What is the color of the prolegs? How are they marked? Describe the prop-leg. What is its use?

Observe the caterpillar eating a leaf. How does it manage so as not to waste any?

Have you found the egg from which the caterpillar came? What color was it? Where was it laid?

How does the young caterpillar look? What are its colors? Has it spines?

Watch one of these caterpillars shed its skin. How does it prepare for this? Does it spin its carpet? Where does the silk come from? Describe how it acts when shedding its skin?

When the caterpillar is full grown how does it hang itself up to change to a chrysalis? How does it make the silk button? Does it weave a loop or halter? If the halter is woven what does the caterpillar do with it? Describe how the

last caterpillar skin is shed. How does the insect get free from the molted skin?

Describe the chrysalis. What is its general shape? What is its color? Is it easily seen? Can you see where the wings are, within the chrysalis? How is the chrysalis supported?

How does the chrysalis look when the butterfly is about to emerge? Where does it break open? How does the butterfly look at first?

#### THE BUTTERFLY

What is the ground color of the wings? What are the colors of the markings? Describe the hind wings. What colors are on them that are not on the front wings? How do the markings on the under sides of the wings differ from those above? How does the ground color differ from the upper side? What is the color of the body of the butterfly?

When the butterfly alights, how does it hold its wings? Do you think it is as conspicuous when its wings are folded as when they are open?

Watch the butterfly getting nectar from a blossom and describe the tongue. Where is the tongue when not in use? Describe the antennae. How do they differ from the antennae of moths?

### A Note on the Hibernation of the Pupa of the Sphinx Moth

J. ANDREW DRUSHEL  
Harris Teachers College

Early in October, 1916, several fully grown caterpillars (the so-called tomato worms) of the five spotted sphinx (*phlegethontius celeus*) were brought from the Harris Teacher's College garden to the class room of our nature-study classes for observation. Shortly afterward opportunity was provided for transformation into pupa stage by placing two of them in a pasteboard box (inside dimensions  $7\frac{1}{2}$  in. x  $4\frac{1}{2}$  in. x 3 in.) full of moist garden soil. The lid of the box had several air holes in it.

Several hours later one of the caterpillars buried itself, the other escaped. The question then was asked: Will keeping the box during the winter in the room under ordinary school room conditions hasten the transformation from pupa to imago? In other words to what extent is temperature a factor in determining the period of hibernation?

The box was kept covered. The soil was occasionally moistened. At various times enough soil was removed to permit examination of the pupa, with a view to determine whether it was dead or alive. On May 22, 1917, a well formed imago appeared.

In this case it would appear that ordinary room temperature did not hasten the transformation from pupa to imago.

## News Notes

### CALIFORNIA

Newspapers and County Libraries of northern California are cooperating enthusiastically in the plan of testing out the possibilities of nature-study in every city and rural school of the state, this first story of the campaign appearing recently in the *Sacramento Bee*.

#### HUMMINGBIRDS, RICHLY GARBED, HERE IN NUMBERS

"The wedding dance of the Anna's Hummingbird," said C. M. Goethe to-day, "may be witnessed this week in many a garden in the coast counties. Stripped of feathers, the body of this hummer is hardly larger than a bumble-bee's. The diminutive wings have finished the long journey from its Mexican Winter quarters. The males, however, are none too tired for their energetic wooing.

"The modestly garbed but attentive female sits on a limb. One, perhaps more, of these winged jewels commences the dythmic movement, flashing in the peculiar, pendulum-like swing of the wooing dance. It is a sight once seen never to be forgotten.

"California is rich in humming-birds. While the East has only the ruby-throated, this State has six kinds. No California child should reach the high school age without the pleasure of intimate friendship with each variety. Good bird books can be obtained through any branch of any County Library in California. Some, like Wheelock and Bailey, have keys which guide the beginner in identifying birds by their colors."

The idea is to call attention to events in Nature's Calendar through reliable observations by several correspondents, who send them to a central office where they are given a relation to books in the libraries and are then published. People interested may obtain the library books through any of the 2141 branches of the County Library System.

### MASSACHUSETTS

#### NEW ENGLAND FEDERATION OF NATURAL HISTORY SOCIETIES

Portland Society Natural History.	Newton (Maynard) Soc. Nat. Hist.
Josselyn Botanical Society.	Worcester Natural History Society.
Knox Acad. of Arts and Sciences.	Appalachian Mountain Club.
Maine Academy of Science.	Barton Science Club.
Vermont Botanical and Bird Club.	Boston Society Natural History.
Hartland Nature Club.	Boston Malacological Club.
Rhode Island Field Naturalists' Club.	Boston Scientific Society.
Providence Franklin Society.	Boston Mycological Club.
Rhode Island Entomological Society.	Brookline Bird Club.
Lawrence Society Natural History.	Cambridge Entomological Club.
Andover Natural History Society.	Home and Field Club.
Fall River Society Natural History.	New England Botanical Club.
Bristol County (Taunton) Acad. Sci.	Science Club.
Marlboro Society Natural History.	Fenway Natural History Club.

The Annual Meeting of the Federation was held for two days in April at The Children's Museum, near Jamaica Pond. The program included an exhibition of contributions from various societies and individuals, as well as visits to other museums, and an excursion to the Arnold Arboretum as guests of the Brookline Bird Club.

#### NOVA SCOTIA

*The Journal of Education* of Nova Scotia last issued shows clearly that the teachers of that province are busy laying a broad and firm foundation for the development of future naturalists. They are stimulating their pupils to make very accurate "nature" observations which they send in twice a year to the Inspector who transmits them to the Superintendent of Education. The records are called *Phenological Observations* and are published with comments in the *Journal*. When the pupils are going to and from school they soon become careful observers of the first leafing, flowering and fruiting of trees; of the first appearance of the migrating birds in both spring and fall; the dates of the beginning of farm operations, as plowing, sowing, and planting; dates of the opening of the rivers, of the last spring frost; the number of thunder storms. Truly, such observations are bound to produce a generation of observing boys and girls.

It would be well if every school in America could adopt this method. Nature-study would be given a background which would simplify the work for many teachers.

*The Rural Science Training School* began its summer session at Truro on July 11th, to run through August 9th. The studies are pursued at the Normal and Agricultural Colleges, and at the completion of the course, the candidate is granted a Rural Science Diploma. He may, if he chooses, pursue at the same time a course in Physical Training, for which he obtains a certificate.

School exhibitions were held this last year in 130 schools of the province with the result that both the schools and the public are more interested than ever in Children's gardens, manual work and in nature collections. The exhibition, if properly used, is of great value educationally and socially.

#### NEW YORK

*Cornell University*. The nature-study classes under the direction of Mrs. Comstock, assisted by Professor George Embody and by Miss Cora Smith of Erie, Pa., have had an attendance of seventy teachers representing all parts of the United States.

*Chautauqua Institution*. Professor Schmucker assisted by Miss Emma Davis of Johnstown, Pa., have been conducting classes of enthusiastic nature students during the summer.

#### PENNSYLVANIA

*Sewickley*. The Sewickley Valley Audubon Society, of 234 members, has had a year of increasing activity, with lectures by Ernest Harold Baynes on feeding and attracting birds; by W. S. Thomas (City Ornithologist of Pittsburgh) on the placing of bird-houses; and by Henry M. Oldys, who was employed for lectures, study classes and outings which consisted of morning and twilight field walks conducted twice a week for six weeks in May and June.

Before Mr. Oldy's arrival, study classes had been held in the public schools for children in the afternoon and for adults in the evenings. The bird specimens so freely loaned by Director Hoffman of the Carnegie Museum were of great assistance. The manual training classes of the public schools turned out quantities of bird houses, which resulted in there being scarcely a garden in the vicinity not supplied with one or more bird houses.

*North East* has a wide-awake Nature Club which recently showed its vitality by donating \$5 to the National Audubon Society and by arranging to keep *Bird Lore* magazine and *The Monthly Star Map* at the public library free of access to all.

The manner of conducting the meetings of this club is truly a model.

Each member brings an exhibit of some specimen in which he is personally interested and about which he has prepared a brief talk. At the May meeting this included an exhibit of moths by Miss Ruth Porter, who showed five specimens mounted under glass. Her talk told of gathering the cocoons from trees, of cutting out the side of one so that she could see the changes of the pupa, and how she finally saw the beautiful moth emerge. Miss Esther Leet showed a lively pair of Pickering's tree frogs and told of their wonderful concerts in spring and fall, and of how they change color, like the chameleon.

Other exhibits and talks included a spotted salamander, novel mushrooms, false and true mitrewort, staminate and perfect maple blossoms. Attention was called to the fact that the showy cowslip blossom has no petals.

Mr. L. B. Cushman talked on St. Petersburg, telling of the town, the climate, the churches, the saloons, the birds and the snakes.

Several teams were appointed for special summer work. One team will work on ferns, another on moths and butterflies, another on mosses. The fern team has eleven members and is doing individual work.

## RHODE ISLAND

*Rhode Island Normal School.* The recent Arbor Day festivities of the State Normal School, under the direction of Professor Wm. G. Vinall, were so extensive and so inspiring in character that readers of THE REVIEW are going to enjoy learning of the splendid Field Day in the Woods and of the special school exercises, as we publish them in the October number of the magazine.

*Rhode Island State College* is cooperating with the U. S. Dept. of Agriculture in the endeavor to reduce the cost of living. Garden and canning clubs have been organized among the children and in local societies of men and women. Bulletins, demonstrations, and lecturers are sent upon request.

*The Providence Chamber of Commerce* through its Planting Day Committee for 1917, repeated in April the plan so successfully inaugurated a year ago for the beautification of homes in the city. School children and factory employees cooperated in the planting of 50,000 Bush Honeysuckles and Golden Bells. Two days before the Planting Day, Mr. Carl Bannwart, of the Newark, N. J., Shade Tree Commission, lectured on "The City Beautiful," to which the public was cordially invited.

Last year the Committee planted 23,000 Spiraea and Rose Bushes in hundreds of yards.



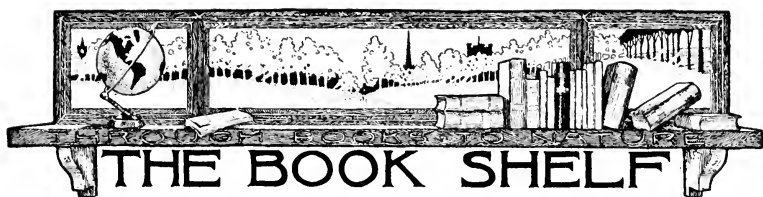

To Doubleday, Page & Co., all nature lovers are deeply indebted. From its beginning this Publishing Company has bent its energies to making the reading public intelligent about its out-of-door environment. The Nature Library, a dignified and remarkable series, has been a bulwark of interesting and valuable information for the nature lover. The Editor has actually worn out some of the books of this series and cheerfully replaced them with fresh copies expecting to wear them out also.

Again we are all indebted to the Doubleday, Page & Co., for the charming and enlightening books of the *Worth Knowing Series*, each well illustrated and interestingly written and costing only \$1.60 a volume.

*Birds Worth Knowing* comprises a selection from the writings on birds of Mrs. Doubleday (Neltje Blanchan) and no one of all the writers concerning bird life has written more understandingly or charmingly than she. This volume begins with a chapter on "What birds do for us," and makes a very clear and useful classification of those that care for the foliage, those that have charge of the bark and of those that are care-takers of the ground floor.

At the beginning of the account of each bird is given its color, description, range and migrations, then follows a truly interesting story of the bird's ways and habits. The book is illustrated with 48 colored plates, which are beautiful and most useful in identifying the birds. At the end of the volume is a color key. About 130 birds are described, including some of the more important owls, hawks, bitterns, rails, ducks and geese.

*Trees Worth Knowing* by Julia Rogers is reserved for notice in the Tree Number of THE NATURE-STUDY REVIEW.

*Wild Flowers Worth Knowing* is a volume selected from Mrs. Doubleday's writings about flowers. Mr. Don Dickinson made the selections and arranged the discussions of the flowers according to the classification of the revised Gray's Manual and has done a good piece of work. Mrs. Doubleday in the preface gives the keynote to the volume when she says, "For flowers have distinct objects in life and are everything they are for the most justifiable reasons, i. e. the perpetuation and improvement of their species. To really understand what the wild flowers are doing, what the scheme of each one is, besides looking beautiful, is to give one a broader sympathy with both man and nature and to add a real interest and joy to life which cannot be too widely shared." Thus she states exactly the aims of nature-study in relation to plants. Nearly 200 plants are described and discussed. A color key is given on the last pages and the book is illustrated with 48 very beautiful pictures in color.

*Butterflies Worth Knowing.* By Clarence M. Weed.

This attractive volume begins with a very interesting chapter on the structure and habits of butterflies, including their selective color sense, heliotropism and also the rearing and photographing of butterflies and preparing them for collections. Professor Weed discusses each butterfly in his usual lucid and charming manner, bringing out the chief points in its life history. A very important point he makes is to call attention to those phases in the life histories as yet unknown, so as to stimulate the observer to make original and useful records and thus add to the sum of knowledge. There are colored plates of 48 species. Many plates are made from Mr. Denton's transfers of scales. However several are made from drawings of Miss Mary E. Walker and Mr. W. D. Beecroft, which include the pictures of the caterpillars. There are many other illustrations from photographs and drawings. Professor Weed has produced a useful and attractive book and one that will be of real use in interesting the public in these beautiful insects.

*The History of Science* by Walter Libby, Professor of The History of Science in the Carnegie Institute of Technology. Houghton, Mifflin Co. \$1.75.

This is a wonderful little volume and makes the reader marvel how so much can be clearly and satisfactorily expressed in the space of less than 300 small octavo pages. The titles of the chapters are a part of the excellent teaching method of the volume,—for the title gives the basic principle of the phase of science discussed under it. The first chapter, giving an account of the science of Egypt and Babylonia, is entitled "Science and Practical Needs," and shows clearly that science is founded on necessity. The Greek science as exemplified by Aristotle is discussed under "The Influence of Abstract Thought." The story of the discoveries of Benjamin Franklin is given under "Science and the Struggle for Liberty," and thus through the twenty interesting chapters of the book. The last two are on "The Scientific Imagination" and "Science and Democratic Culture," both of which are remarkable, and the last should be read and pondered by every thinking American. It is to be hoped that Dr. Libby will sometime expand this work to several volumes.

---

The October issue of the Nature-Study Review will be a Tree Number. Do not miss it.

# THE NATURE-STUDY REVIEW

VOL. 13

OCTOBER, 1917

No. 7



## My Tree

ELMER J. BAILEY

Assistant Professor in English, Cornell University

I do not know when I first made acquaintance with my tree,—certainly not until a long time after I had at least become conscious of its existence. A city boy, I made my earliest visit to the country in the summer of my fourth or fifth year, spending a week or more in a low, white gambrel-roofed farmhouse standing half way up the slope of a long eastward looking hill. At the foot of that slope, many, many years before my birth,—many, many years before my father's birth indeed,—an elm tree had taken up its abode. In the days of my childhood therefore, what had once been but a sapling stood forth a stately tree, half concealing its sturdy upward reaching branches in the delicate greenery of its almost lacelike foliage. Beautiful it was in every way, for it stood alone in solitary grandeur and grace at the bottom of a little hollow into which the dusty public highway slowly descended only to climb rapidly up the abrupter slope beyond. Still altho I often wandered back and forth upon that road, passing and repassing the friendly elm tree, I cannot now recall that on my first visit to the country—or even on my second or third,—did I give it so much as a thought. Never-

theless, patiently awaiting my notice, it must have always been standing within the straggling fence that meandered along the straighter foot path cut into the half worn grass and paralleling the open yellow wagon track where no child of my age dared so much as venture.

Every spring and summer found me at the old farmhouse, and once I spent a whole blessed twelve-month there. It was during this long visit that I established my friendship with the elm tree. I was ten years old and my going and comings between the city and the country had not been few. Yet I had never been able to adjust my city-bred ways to the less formal life of the farm, and as a result many of my hours, and even many of my days,—were far from happy there. One afternoon late in May, I distinctly remember. My sturdier cousins had been more than usually trying and in one of those fits of rage which result from the little tragedies of childhood, I tore out of the house and rushed down the road to the bottom of the hollow. Climbing the fence, I threw myself down at the foot of the tree, too proud to cry, too angry to be articulate, though I trembled with wrath, and could feel the hot blood coursing through my veins. Suddenly I was conscious of a presence,—the presence of the tree.

In an angle of the rail fence, beneath the green grass, spread out no doubt the far-reaching roots of the great elm. Of them, of course, I had little thought; nor did I pay much attention to the large stones—almost rock-like in size—which some tiller of the soil had removed from the field and scattered there out of the way of his plow. Between these stones there was no inconsiderable amount of rather rank grass, but there was more—there were violets in bloom. I do not know that there is any connection in general between elm trees and violets, but nothing can ever make me believe that my elm tree had not adopted those violets nestling about its roots unto its kindly protecting care. Then and there I woke to a new truth—the Greeks were right when they believed that every tree had a soul, that some dryad made her home within the shelter of its roughened bark. Timidly yet eagerly, I lifted my gaze up the straight trunk, on through the branches until it lost itself in the mazes of the feathering of the farthestmost twigs. The light wind swayed the leaves, and their faint rustling was as a voice—the voice of the nymph—the voice of the tree which had so long awaited my coming and my tardy love.

My anger was gone. Strange as it may seem, I did not linger long with my new friend. Instead I gathered myself together and made my way back to the house. Never again was I to be quite the same boy that I had been. What had happened to me I of course did not then know; but I now know that a spiritual regeneration had taken place in my soul. I would not have spoken of my experience to my cousins, had I been able—as I was not—to put it into words. Even childhood has its secrets which it hides from all its companions. But I did spend my days—and I would have spent my nights, had I been allowed to do so,—with my new friend. Early in the morning I was beside it; reluctantly I left it when I was called from the farmhouse to my dinner and my supper. Sometimes in the long light evenings of late June and July and early August, I would slip away and spend a little time with the tree. It seemed to bid me a goodnight when I was called from the house, and I left it with the less reluctance, for the window of my room looked out towards it and I could see it from my bed. Some times the moon was very bright and all the stars were out. Then my tree was wide awake too, and seemed now and then to nod and beckon to me from its place there by the road.

I cannot say that I learned so very much about my tree. I knew that my cousins spoke of it as the old elm tree, but so far as I was concerned with names, it might just as well have been called by any other. To them it was an elm tree and nothing but an elm tree. To me, it was my friend, my only friend. Never could I have brought myself to talk about it to them. Too well I knew the shouts of laughter with which any attempt to tell my feelings would have been greeted. Experience had taught me wisdom and I held my tongue. No doubt this very reticence on my part was what made the tree so dear a friend. We had a secret; and as I trusted the tree, so must I prove myself worthy of the trust which I never doubted it reposed in me.

I have learned many things about elm trees as the years have passed by. No doubt my friendship for the tree in the hollow has stimulated interest in all its brothers and cousins. I know that varieties of the elm are found in all parts of the globe—at least upon all the continents; I know that it flowers before the leaves appear; I know that its wood is put to widely different uses; I know that the inner bark of some varieties is used in making rope, that parts of other varieties are supposed to have medicinal value, and that

twigs of still other varieties are supposed to possess the virtue of acting as divining rods. Truly I know many things about the genus *Ulmus*; but my elm tree is not of that ilk. It may be of the earth, but it is not earthly. As it was in my youth, so is it still, so may it ever be, of another world than ours. Peace be with you, O my elm tree! The years are many since I sat beneath your sheltering branches, yet my love for you has never waned. I close my eyes and I am with you, old friend, once more. The memory of what hath been can never pass away.



Photo by Verne Morton.

A Bracket Fungus

### Boy Scouts to Combat Shelf Fungi

We love the trees and we are very interested in and friendly to the shelf-fungi that we find growing on old decayed stumps and logs. But when we see a shelf-fungus growing on the side of a living tree we feel the same sympathy and pity that we experience in looking at a cancerous growth on a human face. The spores of these injurious fungi find access to the living tree through an

injured place in the bark, a broken branch torn off by the wind, and too often from the hack of an axe in the hand of ignorance and carelessness. After the wound is made the spores settle within it and from them grows the mycelium, the fungus threads which push their way into the heart wood, getting nourishment as they grow, and their path is marked by "rotten wood" for rotting simply means the yielding of the substance of the healthy wood to these voracious threads which first push in and then push up and downward, weakening the tree and sometimes even girdling it by killing the cambium layer. After these fungus threads have flourished for a time and greatly damaged the tree, they seek another wound in the protecting bark or even push out through the door which they entered and begin to form their fruiting organ which we call the Shelf or Bracket Fungus. One of these is composed of a hard upper surface to which is attached a layer of very small honeycomb-like, tubular cells; in each tube cell spores are developed. When ripe the lower end of the tube opens, letting the pernicious spore dust out to be carried by the wind, until some of it finds another opening into a living tree.

Now for the Boy Scouts' work. It should be a part of their training to look for these accidental wounds in valuable shade trees, and when found, if the wind has broken a branch and splintered it, to saw or cut the splinters off leaving a smooth stump, and paint it over; ordinary paint will do if renewed each year or two, but a coat of tar is better. If a boy scout sees a shelf-fungus growing on a living tree he should cut it out and paint a coat of tar over the wound. This may not save this particular tree from the damage of this special attack, but it will save other trees because each year a shelf-fungus grows larger and has more surface for the tubes that bear the spores, and thus becomes a growing menace to all the trees in the neighborhood.

Professor H. H. Whetzel intended to write an article for this Review, outlining specifically the work of boy scouts in combating one of the most vicious of these fungi species, but his extra duties entailed by the war prevented him from giving us this valuable information, but it will be given in some later number.

## A Wise Old Oak

RUSSELL R. LORD

Battery C, Maryland Field Artillery

A wise old owl sat on an oak.  
The more he heard the less he spoke.  
The less he spoke the more he heard.  
Why can't we all be like that bird?  
—*Old Song.*

True, very true; but have you heard  
About the oak on which the bird  
Would sit and look so wise? The tree  
Was many times as wise as he.

Everywhere you go, almost, you will find wise old oaks, and if you can get them to talk to you there's no end to the things they can tell you. Maybe you don't believe that; maybe you think you know a lot more than any old oak that ever grew. And maybe you do, but again maybe you don't. But be sure of one thing—an old oak tree has a lot more sense than any owl that ever sat in its branches and hooted.

Owls haven't such an awful lot of sense; they look a lot wiser than they really are. We are always a little afraid of owls—they are so silent and spooky and unfriendly, and they seem to be thinking so deeply all the time, that they have made us think them really remarkable animals. But did you ever hear of an owl doing anything about all of the things it thinks so hard about? Now, trees don't make such a show of their thinking, but they are doing something every minute and the "thinks" they do are generally calculated to make people happy and friendly, instead of scaring them to death.

But before you can learn anything from an old oak tree you must know it pretty well. This may mean that you know the kind of bark it has and the family it belongs to, and the way it lives and the work it does, and so on, or it may mean that you just know how that oak *feels*, whether it feels like playing and throwing its branches about to the winds, or whether it feels strong and brave as it looks out over the quiet country. Some people come to know trees one way and some the other, but everybody that wants to can be good friends with them and talk with them when he feels like it.

An oak has talked to you before this—No? Well, you know this, don't you? An oak is big and strong and very kind and friendly. Who told you? Why, the oak itself! And it told you



all this when you were paying hardly any attention at all, when you were just going past. Think how much more it could have told you if you had just stopped and listened.

People are funny that way. They think that anything that isn't somebody's brother or sister can't talk. And all the time dogs are wagging their tails and cats are purring and the winds are making soft sounds in the top of our wise old oak. None of us can remember what we used to think to ourselves in our cradles before we could talk, what we used to have to say to ourselves before we knew a single word of the English language. But if we have baby brothers and sisters we know that we did have a lot to say to ourselves and all without words—they do it, we know, and we were as smart as they are, every bit.

Well, that's about the way to talk to a tree—without words, just with ideas. And when you've had your talk you can put it in words, if you want to, the same way I'm going to do mine. Some grown-up people may not believe what you tell them about your talk with the tree, but what does that matter! It only means that they don't understand the tree language of thoughts instead of words.

---

The Wise Old Oak that told me all the things I am going to tell you stands all alone, almost in the middle of the largest field on our farm. It is a Black Oak—you can tell its brothers from the cousin Whites and Scarlets by the big broad leaves, with rounded cuts, not so very deep. The points of these leaves are not so sharp as those of most of the other oaks and the acorns are large and bitter, with caps too small for their heads.

We had hay in that field, I remember, the summer I had my talk with the Oak. The reason I remember that is because I was lying on a haycock at the edge of its shade when I ought to have been out in the sun piling up more haycocks. But it was late in the afternoon and mighty hot, and I was lazy, so I just loafed in the shade and presently began to wonder about the old oak over my head. That's one of the best ways to get an oak to talk—to wonder about it. Almost before I knew what was happening, the Oak was answering the questions that were in my mind.

"No," it said, "I'm not a bit lonely up here on my hill, altho I am very glad you have come to talk with me. There was a time when I had plenty of company—a little too much, I thought, when

other trees crowded so close around me and I got a bit tired of fighting for food and for the light of the sun on my leaves. But, everything considered, it was good fun and a fair fight—I enjoyed it. I am the only one left now; how many of us there used to be! Do you see those trees way yonder?”

I looked far out over the valley and up to the horizon hills, all woods on top. The sun was just going down behind them and it was very wonderful to see. The oak went on:

“There was a time that when the winds blew among my branches and then away, they were carried by other waving branches all the way to the branches of those, my brother oaks—yes, and further than that, too. We were all one big forest, one big family, in those days.”

“How long ago was that?” I asked.

“We do not count time as you do, but it was long before you were born, and before the time of your father, too. The first man I ever saw always carried with him a long gun, and powder in a powder-horn. He wore a coon-skin cap and could live in the woods just as well as he could at home. He used to talk to me, too, and twice he slept under me, altho I was smaller then and there were many finer trees about. That was long ago, but I had lived long before that.

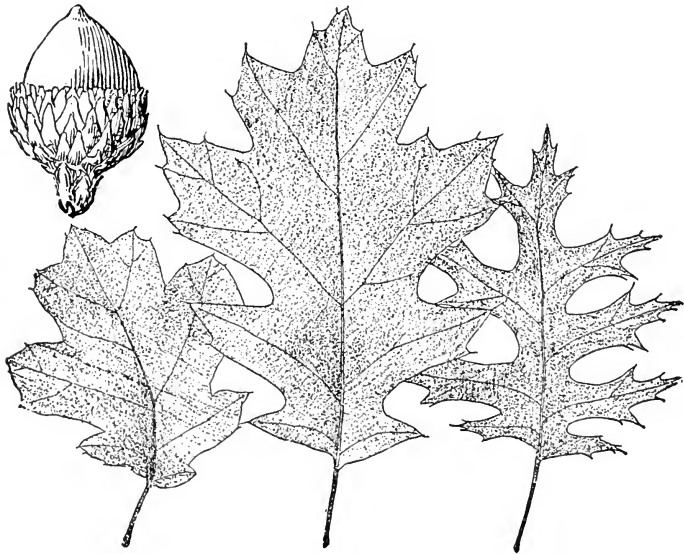

Leaves and acorn of black oak

"I can remember when I was born, and how frightened I was when I pushed my first folded leaf up thru the warm soil and into the sunlight. My mother was there, but she was far above my head and could not help me, for we trees are not like you children—from the very first we have to fight our own way in the world. And if we fail we must wither and go back into the earth and rest for a long time, and gather strength to try again. Oh! it was a wonderful game that we played, my brothers and I, and the rest of the little trees around us. You children wrestle for a little while to see who is strongest and run a little ways to see who is most fleet, but we little oaks wrestled quietly among ourselves all day long, and were always racing upwards toward light and room, the prizes overhead. All day we would wrestle and race among ourselves, so quietly that you might not have known it, and at night, when the sun went down, we were quiet and slept standing, side by side, so that we might start our game again as soon as the sun arose. So we lived those first summers and when fall came I stood highest of all my age—taller, too, than some of my big brothers,—and I had the most leaves to throw upon the ground,—leaves that shrivel and grow brown and disappear in the warm earth when the winds are cold, but which come back sometime and are green again, perhaps on some other tree. And some of the little trees with which I had raced and wrestled were not strong enough. These withered and followed their leaves back into the ground. I missed them, but I was not sad, for I knew that they would come back again as soon as they were rested. We trees know that we can never die and stay dead; that is one way in which we are wiser than a lot of people.

"And so it went thru all the springs and summers, thru all the falls and winters, which followed. We raced and wrestled so that our leaves might be above all the rest and catch a lot of sunlight, and make a lot of starch. And underground our roots grew bigger and stronger and pushed out faster and further, so as to reach the water and other things that run up our trunks and turn the starch of our leaves into sugar, which we eat. I was strong and a fast grower—of all the young oaks I was tallest; I got the most sunlight on my leaves, and so made the most starch and sugar, and had the most to eat. I was tall and straight in those days; acorns grew among my leaves and fell, and went into the soil,—and presently racing, wrestling children of my own were all about my

feet. But then men with loud voices and sharp, bright axes came into our woods. They trod my children under their feet and slashed down all of the trees that stood around me. Do you see this empty space which I try to hide with my branches? That is where my mother fell on me when they cut her down. Of all the trees on this hill, I was the only one that they let stand, because they said I was "Grandfather's Tree."

"Times change and everything changes with them. The day of great forests is gone, but you must not think that the trees of the forest are dead—I do not think so. Man has not allowed trees to grow on this field again, but year after year, my mother and brothers and friends have come back in the corn and wheat and grass that men have planted here; in the weeds that grow up, year after year, in the fence corners, and wither down in winter, and return with spring. Men are not always wise enough to see this, but I know my friends—there is the same green in their leaves; they make starch and eat sugar in the same way; there is the same sound among them when the wind blows. My old friends are always about me. They do not look the same, perhaps, but they know me and I them, and if you listen sometimes you may hear us talking together.

"I am very old now and getting tired. Soon, I think, I too will fall and wither and go back into the warm ground for a good long rest. The people will say, "Look! the old oak is dead at last." But you will not believe that, will you? If you do, you will not be as wise as an oak, tho you may be as wise as an owl."

---

"When I go to the woods, it is like going among old and treasured friends, and with riper acquaintance the trees come to take on, curiously, a kind of personality, so that I am much fonder of some trees than of others, and instinctively seek out the companionship of certain trees in certain moods, as one will his friends.

"I love the unfolding beeches in spring, and the pines in winter, the elms I care for afar off, like giant, aloof men, whom I can admire, but for the friendly confidence give me an apple tree in the old green meadow."

—DAVID GRAYSON in *American Magazine*.

## The Oak

DONALD THISTLE

Reviewer of the past, and monarch of the present,  
How thy strong rugged self speaks 'gainst the foibles of o'erpowering  
man.

Though once thy time was measured all in moons,  
As red skinned sons of Nature reckoned life,  
Long since that all has changed; and in his stead,  
The artificial white man drives the world;  
And in the driving loses what is beautiful.  
He cursed the nobler owners of the land,  
And pushed them forth as sheep 'mongst hungry wolves,  
As herds of cattle, bison, wretches, dogs,  
He branded these first men who found life sweet.

And worse, he called them liars, sneaks, and thieves,  
Yet had no worthier sons to fill their place.  
All this, O Worthy Sire, thou hast seen, and more;  
The love scene of the Indian maid has passed.  
Beneath thy sturdy boughs, how oft a song  
Of simple truth and melody was outward sent,  
Through shade, across the silver sheen and on, until  
It lost its echo in some distant woods.  
How many a feathered songster of God's choir  
Has loved and in your boughs to you, poured forth his song.  
The greatest secrets hast thou overheard.

And yet, no harm when only thou dost hear,  
For only after centuries of time,  
When all the idle whisperers have gone,  
Dost thou consent to tell to anyone  
The history of love in times before.  
Full many a Spring has come and Summer gone,  
And flocks of birds have often sung the songs,  
And other woodland folk have trusted thee  
For home, and shelter; where to rear their brood.  
The Indian while he prayed unto the sun, his God,  
Has lived, told secrets, and in thy shadow died.

Are my poor ears too harsh to catch thy words,  
Thy note of truly 'most prophetic strain,  
Must I then bear the evils of my race,  
And never hear a word thou hast to say?  
Or wilt thou drop just here and there a word  
Of how the Springs have come and gone before.  
How this one differs, or perhaps is like  
Those former ones; and then just tell me this—  
Why in this busy world we have no time?  
For thou hast lived for many moons serene and strong and loved,  
And still remain, a noble gift to all posterity.

# Necessity for Greater Accuracy in Describing American Trees

Dr. R. W. SHUFELDT

Washington, D. C.

(Illustrated by reproductions of three of the author's photographs)

During the autumn of 1916, I paid some little attention to the various species of indigenous oak trees (*Quercus*) found growing in the woods and open country about the city of Washington. I collected, with great care, the fruit and leaves of ten or more of what appeared to me to be distinct species. I likewise photographed a number of oak trees of this region, as I found them growing in nature, for the purpose of comparing their different styles or manner of growth, collecting from these trees, as well as from others, numbers of acorns, leaves, branches, and so on. As my investigations progressed, I was reminded of what the late Professor Lester F. Ward—a most profound botanist—once said to me, at the time he had just described a new species of oak for the District of Columbia: “If you ever take up botany, be very cautious when you come to study the genus *Quercus*; they are a most puzzling lot, and liable to discourage you.” When my collection and photographs came to be to some degree representative of this quercusine group of the Beach family (*Fagaceæ*), I submitted the material to Mr. P. L. Ricker, Assistant Botanist of the Division of Plant Industry, of the U. S. Department of Agriculture, and to his assistant, Mr. Peterström. Through their courtesy, all of my specimens were quickly identified, and these identifications I duly compared with the descriptions (illustrated) given in the last edition of Gray's “New Manual of Botany” (Robinson and Fernald edition). On page 338 of this work we are informed with respect to the oaks that “all the species [are] inclined to hybridize freely.” In the case of the descriptions of some of the species, we are further told that the foliage is “extremely variable” (*Q. falcata*). Of *Q. margaretta* it is said that it “is possibly a hybrid of *Q. stellata* and *Q. alba*”; and in the case of *Q. virginiana*, that it may be a very large tree in rich soil, and a dwarf in sterile soil, the two varieties differing widely. Finally, in the case of others, as in the common Red oak (*Q. rubra*) for example, it is found “passing to var. *ambigua* along our northern border.”

As a matter of fact, I met with the greatest difficulty in identifying the eight or ten species and subspecies of oaks I had collected with so much care in the District of Columbia; moreover, it is more than probable that all the kinds of oak occurring in this region have not been met with by me up to date, and it is still more probable that when I meet with them they will bring added confusion to my investigations along these lines.

In the light of this experience, it occurred to me to select some typical American forest tree, well known and of economic value, of wide range with respect to geographical distribution, and compare what was said about it in standard botanies; this with the view of testing the accuracy of such descriptions, and of entering a plea for greater care in such and allied matters.

In these days, an ever-increasing attention is being paid to the question of heredity in all the representatives of the Vegetable and Animal Kingdoms, in all parts of the world. There is no question as to the importance of all this; but it would quickly be found valueless—indeed harmful—if, in any or all instances, we find ourselves incorrectly informed with respect to everything that refers to the morphology and physiology of the *types* and the *pristine stock*, that is, of the pure strain, in so far as it can be differentiated.

Having this in mind, and before consulting any text-books or other literature on the subject, I asked myself what I knew about such a tree as the Tulip Tree, its scientific name being, in so far as I remembered it, *Liriodendron tulipifera*, from Greek words used by Linnæus to emphasize the fact that the flower of the tree reminded one of a lily or a tulip—an idea that also passed, in part, to the specific name. Then I turned to the botanies, and thus far, well and good. However, I found but this *one* species of *Liriodendron* described, and I began to wonder what was the name of another with which I had long been familiar, and in which the flowers are at least one-third smaller, of a somewhat darker green, and having very little yellow and orange in their petals. Then, too, the marked difference in the size of the dried fruit, in the fall and winter, is very patent, it being also lighter in color as well as appreciably smaller. This kind of *Liriodendron* is very well known to me; but it is not nearly so abundant as the true *tulipifera*, or the species with the large flowers. (Figs. 2 and 3.)

Right here, however, I will say that this is a matter I will not



FIG. 1. A perfect flower of the Tulip Tree (*Liriodendron tulipifera*; natural size, showing almost its entire form and structure. Superior view.

"The tulip tree, high up,  
Opened in airs of June, her multitude  
Of golden chalice to humming-birds  
And silken winged insects of the sky."—*Bryant*.



enlarge upon further in this place; it is my intention, next summer, to photograph specimens of these smaller flowers and fruit, and publish the photographs in order to sustain what is set forth above. One thing is certain; this variety is not due to hybridization; for, according to all the standard botanies, we have but the one species of tulip tree in the United States. Moreover, I am satisfied that it is not due to differences in soil and climate, for both occur, in full health, in the same localities.

We may next consider the descriptions given of the general form and aspect of the full-grown tree as we meet with it in its normal environment. This is an important point in a full description of any tree—important to the botanist, to the explorer, and to the general observer. Turning to the last edition of Gray's *Botany*, we find this point ignored entirely; the description given merely states "A most beautiful tree, sometimes 40 m. high and 2-3 m. in diameter in the Western and Southern States, the timber commonly called POPLAR or WHITE WOOD" (p. 409). It goes without the saying that *Liriodendron* is no "poplar," and the *form* of the Tulip Tree is entirely overlooked in the description.

As to other botanical authorities, I select "The Trees of North-eastern America," by Charles S. Newhall, as an example. This is an authoritative work, as it has an introductory note by Nath. L. Britton, of Columbia College. With respect to the form and growth of *Liriodendron tulipifera*, Professor Newhall says: "Among the largest and most valuable of the North American trees. It is usually seventy to one hundred feet high, often much higher, with a straight, clear trunk, that divides rather abruptly at the summit into coarse and straggling branches." Michaux says: "Of all the trees of North America with deciduous leaves, the tulip tree, next to the buttonwood, attains the amplest dimensions, while the perfect straightness and uniform diameter of its trunk for upwards of forty feet, the more regular disposition of its branches, and the greater richness of its foliage, give it a decided superiority over the buttonwood and entitle it to be considered as one of the most magnificent vegetables of the temperate zone."

This quotation from Michaux appears in Newhall's account of the Tulip Tree in the work just cited, and is an improvement on the description of the author who quotes it. Passing, however, to Newhall's own account, be it noted that he says the Tulip Tree has a "Straight, clear trunk that divides rather abruptly at the

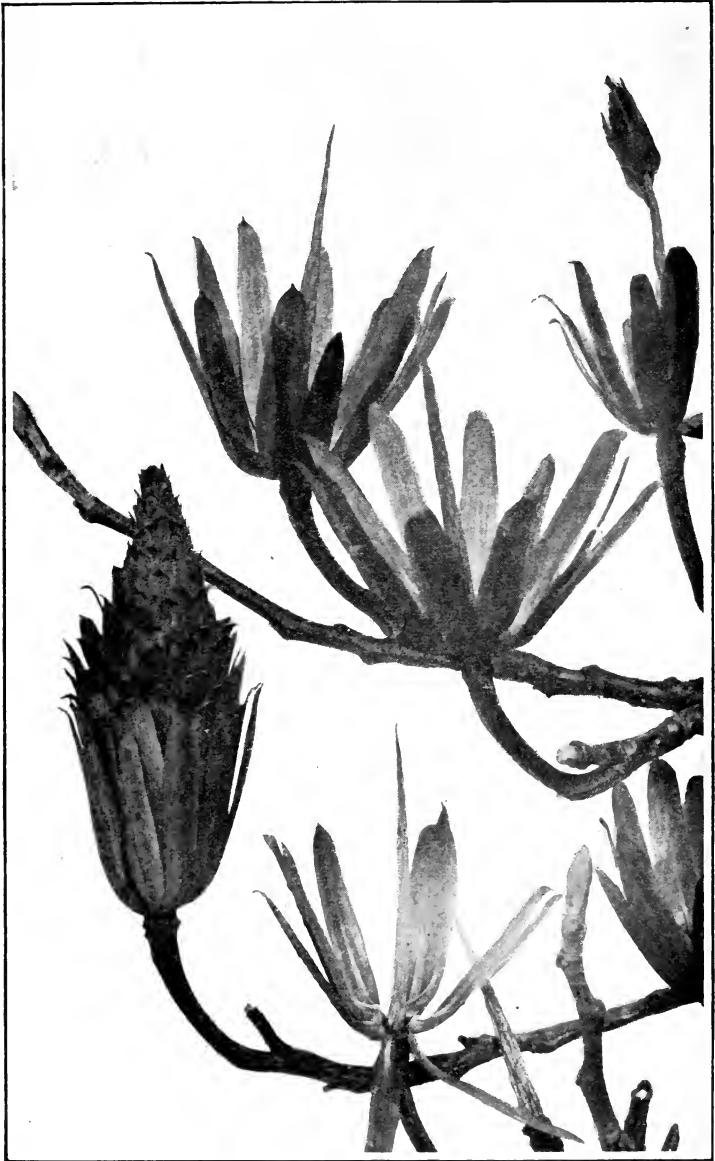

FIG. 3. Fruit of the Tulip Tree (*Liriodendron tulipifera*); natural size, as it appears in the winter months. Various stages are presented, which will be appreciated through reading the descriptions in the text of the article.

summit into coarse and straggling branches." This may be the case in some tulip trees, but it by no means applies to all of them. For instance, it in no way applies to the tree I here present in Figure 1, which is a reproduction of one of my photographs of a superb *Liriodendron tulipifera*, growing on a hill south of Pierce's Mill, Washington, D. C. It is on the right hand side of the road before coming to the bridge close to the mill, and not far from the boundary of the National Zoölogical Park property. It will at once be observed that, although the trunk of this tree is fairly "straight," it is by no means "clear" of branches; neither does it exactly "divide rather abruptly at the summit." Personally, not only have I seen many a tulip tree like this one, but I have also seen specimens wherein the limbs, coming off from the trunk, were much larger, and sprang from the trunk much lower down. Moreover, the trunk of this tree is not always "straight," though it is so in the majority of trees of this species. (See picture on cover.)

There is a very excellent description of this tree in the *Century Dictionary* (Knowlton?), but it likewise ignores the *form* of it. This definition, however, gives a very interesting fact when it states that "It is the sole remaining representative of a nearly extinct type which was formerly abundant, not less than 17 fossil species being known, the greater part occurring in the Cretaceous formation in New Jersey, Kansas, Nebraska, Wyoming, Greenland, and Bohemia, with a few in the Tertiary, chiefly in Europe."

Large tulip trees are very conspicuous in our forests where they occur, especially when they are in blossom, and their trunks are large, clear of branches a long distance up from the ground, markedly straight, and *gradually tapering* to their lowermost branches. These facts should not be ignored in scientific descriptions of *Liriodendron tulipifera*, much less should the exceptions to these general characters be omitted.

I find these loose descriptions and these omissions, in the case of many of our American trees, all the way through our standard botanies; and when the trees are entirely unknown to the student of such species, and the works give incorrect and only partial descriptions, the latter fail utterly to help him as they should, and science falls short of its purpose to just that extent. With respect to the general characters of *Liriodendron tulipifera* I may say, that the flowers show three reflexed sepals and that there are *six petals* (Fig. 2), these latter being arranged in two (2) rows, thus forming

a flatish, bell-shaped corolla, the flower being a fragrant one. Extrorse anthers and a sessile gynophore as in the Magnolia family generally (*Magnoliaceæ*), to which the Tulip Tree belongs. Carpels with two ovules and a fruit like samaras (Fig. 3). The narrow pistils flat and scale-form, forming an elongate and dry cone wherein they are imbricated and cohere. This falls away entire. It is indehiscent, and each carpel contains from one to two seeds at its base; anatropous.

Gray states for the Magnolia family in general "Trees or shrubs, with the leaf-buds covered by membraneous stipules, polypetalous, hypogynous, polyandrous, polygnous; alike, in three or more rows of three, and imbricated (rarely convolute) in the bud."

The feather-veined leaves are very smooth, untoothed, and alternate; marked with dots. Each typical leaf possesses two lateral lobes near the base and two others at the apex. They measure from two to five inches in length. Base cordate, and apex has the appearance of having been cut squarely across, leaving a long, shallow notch with sides of nearly equal length.

This description, taken in connection with what is set forth above and the four illustrations, will serve to present *Liriodendron tilipifera* in such a way that it may be recognized by both amateur and professional botanists in any part of the world.

#### TO OUR SUBSCRIBERS

Please note your expiration date and send in your renewals promptly.

Owing to the increased cost of paper and printing, also to the fact that The Nature-Study Review has not raised its subscription price, we will print only enough magazines each month to cover the subscription list and its normal increase.

A blue check on the wrapper indicates that your subscription expires with this number.



## Leaf Prints

A great stimulus to tree study in fifth, sixth and seventh grades is the making of a portfolio of leaf prints of all the trees in the region. This portfolio may be the property of the school and each pupil contribute a print of special excellence, or what is far better, each pupil may make a portfolio of his own.

The outfit for making leaf prints is simple and inexpensive. It consists of a tube of printer's ink or a cup holding a portion of the ink which almost any newspaper office will contribute to the cause of education. We use an old paste jar for our ink and we bought enough ink to fill it for fifteen cents. Next we must have a flat, smooth surface on which to spread the ink; a slate, a piece of plate glass, or what we have found more practicable, a large square pie tin serves this purpose. Then we need a six-inch rubber roller such as photographers use for mounting prints and this at a photograph shop costs twenty-five cents; a bottle of kerosene to dilute

the ink and a bottle of alcohol or benzine or more kerosene to clean the outfit after using, and we have our outfit ready. Sheets of paper,  $8\frac{1}{2}$  by 11, of almost any quality will do although a smooth-surfaced paper is preferable.

The method of operating is thus. With a stick dip out a little of the printer's ink about as large as two peas, upon the pan, add a few drops of kerosene to thin it. Then with the roller work it over until there is a thin film of the ink over the smooth surface. This is an important part of the work. The film should not be so liquid as to run but should be a smooth, firm, thin coat. Take a leaf by the petiole, lay it flat on the inked surface, hold it firm with one finger, and pass the inked roller over it several times until the veins are well inked. Lift the leaf by the petiole, lay it on a clean sheet of paper on a smooth table, place another sheet of paper over it, again place the finger firmly on the petiole so the leaf cannot stir and blur the print, and with the fingers of the other hand, press the paper firmly but gently over the leaf, working out the veins and margins carefully. Often a second or even third impression can be made without reinking the leaf and these will be better than the first.

Formerly we used a second clean roller for getting the print by placing the leaf between the sheets of paper, holding it fast by the petiole and rolling it once from base outward with the clean roller, putting plenty of strength into the action. Professor W. W. Gillette of Richmond, Va., who gave us our first lessons in making leaf prints and who taught boys of fourth and fifth grades to make leaf prints which are the best we have ever seen, used a letter press to make the prints, putting in several leaves at a time.

Dried leaves may be soaked in water for a time and spread out and dried between blotters under pressure and be used to make leaf prints while they are still flexible. However, green leaves or autumn leaves as they fall are the best. The hickories and horsechestnuts and buckeyes, ash and locusts should be gathered first for these compound leaves soon fall apart.

#### TO MAKE A PORTFOLIO CASE

This is a very neat bit of manual training and if done well will add greatly to the enjoyment of the tree study. Pasteboard, or old book covers, about 9 by 12 may be used. These should have tape pasted on the inside with ends projecting for six inches, then

over these pieces of tape should be pasted very thoroughly a lining of strong paper or thin cardboard. The outside of the portfolio may be ornamented with a leaf print or other device pasted on, and the edges of the cover and lining be bound with passe-partout paper. Or the two covers may have the back fastened together like the back of a book, allowing an inch and a half for thickness.

The teaching value of the leaf print portfolio lies in the accurate labeling of each print. Through doing this the pupil soon comes to know all the trees by their leaves.

A leaf-print portfolio of common shrubs would naturally follow the one on trees; and when the study of botany is begun in first year High, a portfolio of leaf prints of all sorts of plants will be of great help.

## SIR FROST AND THE TREES

WILLIAM PRINDLE ALEXANDER

Old Sir Frost with a wizard's might,  
Rode boldly into the wood by night,  
And blew with a breath, both long and keen,  
A crystal film o'er the aisles of green,  
Till the trees were robed in velveteen,  
And stood bedecked in white.

Then maple, oak and sorrel tree,  
Were touched by a subtle alchemy,  
That changed their modest green attire  
To flaming garb of living fire,  
While sumac vied with lowly briar  
In painted revelry.

Catalpa too, and ginkgo old  
Donned merry masks of shining gold,  
While elm and hornbeam in the wood  
Joined the gay sylvan brotherhood,  
For they were old, and understood  
Sir Frost, and his manner cold.

But one there was, the haughty ash,  
Who 'mid the maple's motley flash,  
In sombrous majesty was found,  
And all in royal purple gowned,  
Awaiting with an air profound  
The Autumn's ruthless lash!

He came again, did Old Sir Frost  
Till the trees had all their verdure lost,  
But shining starlike 'ere its doom,  
The brave witch-hazel sprang in bloom  
To help dispel the Autumn's gloom  
In the wild-wood holocaust!

## The White or American Elm

LEWIS B. HENDERSHOT

Teacher of Biology, East High School, Rochester, N. Y.

Of all the trees that grace our landscapes, whether it be a broad city avenue, a city park, or a bit of country road, the American Elm is to me the most beautiful. With its tall, vase-shaped graceful form it attracts the eye and inspires a feeling of admiration.

When in strange parts of the country I have a feeling of familiarity come over me when I see the American Elm outlined against the sky. It is like meeting an old friend in an unfamiliar place, and the warmth of such a meeting does me good. The feeling of strangeness leaves me and I feel more at ease. At such times I have felt that my good friend recognizes me because when I have paused to admire him he has nodded and bowed his head in acknowledgment.

Perhaps it was because it was the first tree that was brought more closely in touch with my school days that I feel on better terms with the American Elm than the other trees, though I have a keen appreciation of the others. I remember distinctly the big fellow who stood in our school yard, sheltering us in our goings and comings to and from school and while we played during recess, and watching over us as a big brother. Many, many times he served us as "home" in our games of tag and hide-and-seek. What stories he could tell of the people which have passed under his branches, the joys and the sorrows of the passers-by. I wonder if he has their secrets stored up in his heart? How many see him in their mind's eye when they recall their school days, standing there as firm as of old tho perhaps a little wearied from the trials and tribulations of the storms of days past? How many look back and wonder what this or that school chum is doing? Do they look up and pause a little from their work when they meet our friend and turn back in thought to the happiest days of childhood, then going on with their duties with clearer eye, lifted head and squared shoulders after having met the patient and silent friend of childhood? Perhaps some of us have become so engrossed in our work that we have not taken time to turn back the pages of our lives, our eyes have become dimmed, our shoulders stooped, and our brains filled with thoughts of the material things of the world. We say that we have not time, we are too busy. How foolish such an excuse!



To me the American Elm typifies the true pattern of right ideals and living. Clean of body and sound of heart, standing firm through the storms of life, sheltering the weak, strengthening the weary with pleasant thoughts, and reaching up to Heaven for its life's needs. It stands out from among its fellows, head and shoulders, not in defiance or with the feeling of dominance. It has become the beautiful being because of its patient toiling, gathering its food and water from Mother Earth and the air. By taking in the sunshine to its life it knits these together and builds up a wonderful body. Surely, the planters of the great elms of the Harvard campus and the Cornell campus had these things in mind so that the students might learn to build up their own lives with the worth-while things. Do you not feel that the soldiers, who gathered under the spreading branches of the elm on that famous day at Cambridge, Massachusetts, to hear the words of their leader, George Washington, were inspired by that tree to carry on their fight for freedom?

If you have not made the acquaintance of my friend, the elm, I would urge you to seek him out. Study him so that you will have the right to his friendship. You know we have not the right to ask the friendship of Nature's children unless we can offer them ours. We cannot expect to hear their secrets and feel the warmth of their love unless we can give ourselves to them freely and unselfishly. We must prove our worthiness first before we can ask for their wonderful gifts. But how can we prove our willingness to give ourselves in friendship? The first thing we must do is to try to understand them. We must be patient and seek out their secrets by observation and thinking.

But how shall we know, you ask, your friend when we see him? and I answer that if in your walks along the city streets or the country roads, you see a tall, graceful, wide-spreading tree, seventy-five to one hundred and twenty-five feet tall, usually of symmetrical vase shape, with slender limbs and pendulous twigs, you may rest assured that you have found the American or White Elm.

Upon closer examination you will find the bark of the trunk dark grey, rough and coarsely ridged. The upper branches are of a greyish color while the twigs are of a reddish brown. If you were to cut the tree across its trunk, you would find the wood of a reddish brown color, with pale sapwood. The wood is coarse, hard, heavy,

strong, cross-grained and difficult to split. It is very durable in water and soil.

It would depend a great deal upon the season whether you would find buds, leaves, flowers or fruit. You are not to observe our friend in only one season but under all conditions and times of the year. Perhaps he would have secrets to tell, and I assure you he has, during each of the seasons.

During the resting period, winter, you would find buds on the twigs. They are rather sharp-pointed or acute, flattened, and smooth. These are the leaf buds. If you observed closely you would find larger buds placed along the sides of the twigs. These are the flower buds.

Along in March you would find in the place of these flower buds, before the leaves come out, if you observed closely, small inconspicuous, greenish red, true and perfect flowers in umbel-like clusters, that is, the stems of the separate flowers are about equal in length and starting from the same point, slender and drooping. In May, you would find in place of these flowers, smooth, flattened, oval bodies. These are the fruits. Upon closer observation you would find that they each have a seed enclosed in a thin membranous envelope-like structure which extends out and all around the seed, forming a wing. At the opposite end from the place where it is attached to the stem there is a deep notch.

In the summer the tree is in full foliage or leaf. Each leaf is from two to six inches in length, shaped like a section of an egg with the broader end nearer the tip of the leaf. We call such a leaf, obovate. The edges of the leaf are notched, and look like the cutting edge of a saw, each tooth pointing toward the tip. Each tooth is notched, and we call this double notching, double serration. Thus the leaves are double toothed or serrated along the edges. The tip of the leaf is decidedly sharp pointed or acuminate. The base has a lop-sided or unequal appearance. The surfaces of the mature or full-grown leaf are smooth. We also find that the ribs of the leaf are parallel, extending from the central or mid-rib to the edges of the leaf.

To better understand the parts of the tree we must name its parts. The main stem which is thicker than the rest and which comes from the ground is spoken of as the trunk or bole. Branching out from the upper end of the trunk we have the branches, and at the end of the branches the finer twigs or branches which we

speak of as the spray. The branches and the spray make up that part of the tree which we call the head or crown.

Is that all there is to the tree? No, we must think of the roots. There is as much of the tree below ground as there is above reaching out for water and food materials. We find that these roots, in the case of the American Elm, are shallow but extend out at great distances from the tree in search of water.

This water is taken up by the roots and is distributed up into the branches and out into the leaves. The leaves take in a gas from the air called carbon dioxide through little pores in the surfaces of the leaves. There is a green substance in the leaves called chlorophyll which when acted upon by the sunlight cause the water taken up by the roots and the carbon dioxide taken in by the leaves, to unite and form starch. This starch thus formed, forms the basis of the food material of the tree. But the tree cannot use it in the form of starch, so it has to be changed into some form which can be used. So it is changed to sugar. It is then digested and absorbed by the tissues of the tree, and carried by the water into all parts for building up new tissue and repairing worn out ones. The water is not only able to travel from branches to leaves but also from the leaves to the roots. It is continually travelling up and down the tree through little tubes.

Not only do the leaves take in carbon dioxide but they also take or breathe in oxygen. This is needed to aid in breaking apart the food materials so that the plant can use them.

How like our own bodies these same necessary functions are. And if we keep this in mind we will always think of the tree as a living individual.

Not only is the American Elm found in New York and New England but it is distributed from Newfoundland to Florida, and as far west as the Rocky Mountains. So if you travel within these limits you will find your friend, providing of course that the conditions are favorable to its growth.

Beside being a favorite shade and ornamental tree it has other uses.

The wood of the tree is used for hubs, saddle-trees, barrels and kegs, flooring, in boat and ship building, and in the building of flumes. It is also a favorite tree of the Baltimore oriole as site for building its nest. We find the pouch-like, wonderfully woven nest hanging from the tips of the branches, far out of harm's reach.

## The Old Willow Tree

H. S. CROWELL

Teacher of Agriculture, High School, Albion, N. Y.



HIS old willow friend of mine is seven times as old as I am and more than twice as old as any of us will ever be.

This old tree is right across the road from my house and where I can see it every morning as soon as I wake up. When I wake up I always look to see how my old friend looks, for it looks very different on different days.

In the winter I have awakened and found him all white with snow. Again in the spring I wake up on a warm morning and look out to see the golden branches all covered with leaves and then I know that it will soon be time to make whistles from the willow limbs. Did any of you ever make willow whistles?

Shall I first tell you how this tree happened to be where it is? I will tell you the story as my uncle told it to me for the tree is on his farm.

Years and years ago when the Indians were still living in this part of the country a man settled on this farm. He had two little boys who used to go after the cows and help their papa in many ways.

One night while after the cows one of them cut a whip and he still had it when he got home. His father told him that if he would stick the end of it in a wet place it would grow and some day become a big tree.

So this little boy took the whip down by the barn and stuck it in the mud and watched it to see what would happen.

What do you suppose this little whip did? Why the first thing it did was to start growing some roots down in the mud to hold it up and to eat thru. Did any of you ever watch a duck stick its head down into the mud after something to eat? Well, that is the way this little whip sent its roots down. They grew and grew all the time getting something to eat out of the ground. The roots then fed part of what they got to the whip and it began to grow. Then in the spring, leaves began to grow on this little whip and it looked like a little boy in a new suit of clothes. Now the leaves also

began to feed the tree with water and air and it began to grow very fast and soon became a small tree with many branches.

By this time the little boys were big boys but liked to make whistles and still use whips. They cut all the whips they could reach off the tree but do you suppose this little tree gave up and died? Oh! no, it only worked harder and grew taller and had more limbs. The limbs grew up in the air always reaching after more light and rain. The roots went deeper down into the ground and farther from the tree always trying to find more to eat and always trying to hold the tree when the wind was blowing hard.

By the time these boys got to be big men this tree was also a big tree and was so big that one of them could hardly reach around it.

Also now many other people lived near these men so that a town had grown up at that place and the Indians were all gone. Also a great war had been fought and our country was to have no more trouble from other nations.

Soon these two men had little boys of their own to whom they told the story of the tree which they had started as a whip. The tree was now so big that the other little boys then used it to play in and got whips from it to drive their fathers' cows with. It was one of these little boys, who when an old man, and my uncle, told me about this tree.

When the first little boys became old men and died do you suppose the tree died? No, instead it got bigger and bigger, always getting more roots and more leaves. Soon it was way up above the barn and in fact its limbs covered the roof of the barn.

These second little boys, now big boys, used to climb up into the tree where they often played, but they also walked out on the limbs and onto the barn which I think is dangerous, don't you?

Then when the second boys were young men there came that great war when nearly all the men in town went to fight. Think of it, this makes two great wars that this tree has seen.

After the war these second boys returned home to the farm again and had little boys of their own, but the tree was almost too big for them to play in.

Now came the time when the old tree nearly died. The summer was very dry so that the tree could not get enough food, for you know the ground where the willow is must be wet so that it can get its food and grow well. But this was not all, for the insects and worms came and ate the leaves so that the tree could hardly breathe

and every one thought it surely would die. Still, it was hurt again for a heavy wind broke off two of the big limbs.

However, after a long time this tree commenced to grow again and it was at this time that I first knew it.

Ever since then I have watched it to see how it got along.

Just a few years ago the town celebrated its 100th birthday when the tree must have been 150 years old. Now the tree has become the biggest in town and so big that four of you could not reach around it by joining hands.

It still is the one place in town where all the boys go to make their whistles, but now it is so large that they must have long ladders to get any of the small limbs. This tree spreads over more ground than does one of your houses.

Probably when all of you grow up to be big men and women this tree will still be there living on and furnishing whips and whistles for all the boys and girls in town.

Ever since I can remember it has seemed just like a grown-up man to me, always breathing, eating, and drinking thru its roots and leaves without growing much larger.

---

## The Story of a Sycamore

C. W. LEISTER

Assistant in Ornithology, Cornell University



AM pretty sure that every one has a particular liking for some tree that he may have been in contact with during childhood. My favorite tree is the sycamore or, as it is called in some parts of the country, the buttonball tree. The tree I am thinking of stood in the dooryard of my old home in Pennsylvania. It was by far the oldest and largest of all the trees in the neighborhood and many people used to stop and admire it. Its branches towered more than a

hundred feet in the air and its diameter was nearly nine feet. Three years ago this wonderful tree was blown down in a windstorm and we were very sorry indeed that we had to take it away.

You may wonder why I thought so much of this tree, but do you

know that the life of a tree is like an open book to those who can read it? All of the accidents that the tree has had, the years of drought and the years of plenty, all are marked indelibly in the tree. We can read this history when we understand its growth habits, and the every-day life of a tree.

It has often seemed to me that a tree is almost human. It breathes and gets its food almost as we do. It breathes through the leaves and the pores in the bark and the roots. These, then, would correspond to our lungs, and just as our lungs, they take in oxygen and give off carbon-dioxide. But, after all, the chief reason that makes a tree seem almost human is its individuality, I almost said personality.

The leaves are wonderful structures for they also act as "starch factories"; for with the sap from the roots and other materials taken from the air, the leaf, by the virtue of the green material in it and the light from the sun, manufactures starch which is used by the tree. In a tree, then, we have a factory that is run by sun power instead of electricity or steam.

This starch is not used directly by the tree, however, since it can not be assimilated in this form and it must be then changed into sugar. Thus, different elements such as sulphur and phosphorus that have been taken from the soil by the roots are added to the starch and proteids are made. These are used by the tree.

The tree grows by adding a new layer of wood every year. This results in having the wood composed of a series of concentric circles. These are called annular rings. It is by these annular rings that we can tell the life history of the tree.

Going back to our sycamore, then, we will talk about its past: Since the old tree had been blown down we had to cut it up in sections and haul it away and when the logs were sawed, one could easily see the annular rings. I counted these and found that the tree was almost one hundred and fifteen years old, for there were that many rings. Not all of these rings were of the same thickness, indicating that some of the seasons had been very dry and that the growth was not so great as in the years when water was plenty.

Buried entirely in the wood, covered up by the successive layers of the wood, there was a large spike. This had been driven into the tree when it was about twenty-five years old, for it lay almost centered across the twenty-fifth ray. At another place a mark of

some kind had been hung up and had been used as a target for three bullets were imbedded in the wood.

About thirty feet up in the tree a large limb had been broken off nearly thirty years ago. In the cavity thus formed, a family of barn owls had their nest, and every year they raised a family of three or four young. Many was the mouse that went towards the raising of a young barn owl! The old birds would hunt for mice all night and in the day time they would sleep in the hole with the young.

The old sycamore had often been injured around the base and here decay had set in and the tree was gradually weakened and so when the big storm came, the noble old tree was blown down and its days were over.



## A Boy's Friendly Tree

GEORGE H. RUSSELL  
Winthrop, N. Y.

The tree which I am going to write about is one that has been my close friend and companion all thru my childhood and youth. This tree is useful in more ways than one, for besides affording shade in summer and beauty at all times, it grows for its friends the most luscious fruit imaginable.

The name which has been given it is "St. Lawrence," probably because it grows well in northern New York and especially in St.



Lawrence County. The apple which grows on this tree is a beautiful round fruit, usually with a yellowish background and pale red stripes running up and down at frequent intervals on one side. It surely excels in beauty and as for flavor—I would not care to attempt to express in words this superior quality, for one can appreciate it fully, only by eating the ripe mellow apple itself.

This particular tree is perhaps a more beautiful specimen of its species, or of apple trees as a whole, than we are accustomed to see. It divides into three main branches about three feet from the ground and these in turn divide so as to form a tree very symmetrical in outline and covering a wide space so that it affords much shade in summer.

My old friend is situated in the front door yard of my home, hardly eight feet away from the veranda. It is so near that one large branch reaches up and over onto the roof. How long it has been growing there I cannot tell, but I do know it has been there as far back as I can recall.

There are many experiences that I have had with old St. Lawrence, of which I always delight to tell, and perhaps a few may prove interesting. One of the first remembrances I have of it, is that of eating green hard apples, with of course a painful result which is difficult to relate. After such an occasion I would not think quite so much of my friend for a few days, but as I look back I can blame only myself, and justify the tree for of course it did not wish to lose its fruit when green but wanted to raise it to maturity. Besides little boys should know better than to eat green apples after being warned by watchful parents.

I remember other times, when on occasion, I was sent by my mother to cut a switch from this same tree. I never thought at the time how it must hurt the tree to have me break off switches, but nevertheless I was thoughtfully careful to pick a dead branch, and like a true friend my tree offered plenty of such branches. However, I was usually sent after a different kind of a switch the second time. The fact that the switches came from this tree, I never held against it, for of course it wasn't its fault and doubtless it would have been better pleased had I left it alone.

I always preferred to climb this tree above all others and it became one of my favorite haunts. As it was so near the house I could easily climb from it to the roof of the veranda and you may imagine this was great fun.

Later, when I became older and did not care to climb, the tree was just as much as ever a source of pleasure for me. The fragrant blossoms in early summer covered the tree with a robe of white; later the beautiful ripe apples were formed and the older I became the more I enjoyed these particular apples. Many times on a hot summer's day, I have stretched out on the abundant carpet of green grass beneath my tree, which protected me from the hot sun, and in turn I read and slept with a sense of perfect comradeship.

In return for the many kindnesses this tree has shown me, I have tried to care for it as best I knew how. I see that the old dead limbs are removed and the bark cleaned. It has never required much care with the exception of three years ago when I had a hard fight to keep the tent caterpillars from eating up the leaves of my friend and so remove its means of obtaining food. However, they did not do much damage in the end and have not bothered much since.

From the above story you can see why I call this old St. Lawrence apple tree my friend, and I wonder if there is any boy or girl who would not be glad of such a friend as this tree has been to me.

---

## A City Girl's Story of Her Friend, Miss Maple Tree

For Primary Grades

AGNES C. HOGAN

Let me tell you about my dear old friend, Miss Maple Tree. For many long years she lived on the side of a hill, not far from where I could watch her. When I first knew her she was young and graceful, but as years went by she became worn out with work.

In summer she wore the most beautiful dress of soft emerald green. As summer flew away, she became tired of Mother Nature's dress and gradually put on another one. Can you guess what color? Yes, a brilliant rose red dress with faint gold spots here and there. You know she must dress as gay as Miss Scarlet Oak, who lives near her and acts so haughty. Oh, did I tell you why Miss Maple Tree put on such a beautiful dress? Well, she was invited to the Autumn ball. After the ball, which was from two to three months long, she became tired. She must rest after her long busy existence, between spring and fall.

But before she retired for her beauty sleep, she thought it best to send out cards, stating when she would be at home. She did this by gracefully disposing of a number of leaf cards for Mr. Wind to distribute to her numerous friends. Next she carefully blanketed her treasures, which were her buds, in waxy sheets, for Sir Frost was not careful about how he treated her treasure in winter.

Now, Miss Maple Tree did not always go to parties, for she is a busy, lively body, and she runs a starch factory. The cells that make up each one of her leaves form the factory. There are lots of interesting things in this factory. Miss Maple Tree has raw materials which are carbon-dioxide and water. She has machinery too, which is made up of little green bodies called chlorophyll grains. And do you know what power runs this factory? Well, it is sunlight power. Now every factory must have waste material that it does not need, and in this factory it is oxygen. But the most important thing of this factory is the finished product which is starch, and is what Miss Maple Tree eats in order to live and grow.

Miss Maple Tree does not use all this starch at once. No, she is very saving. She sends it down in an elevator through the elevator shaft called the tree trunk. Then she stores it in many convenient places including her cellar which is at the base of the elevator shaft. When she needs it, she immediately sends her messenger boy, little Mr. Sap. He rushes down and around and brings the quantity back.

Miss Tree has also connected with her factory, a subway, which is an extensive root system. Her cars, the rootlets, travel along from the end of the subway all through the underground surface and pick up the raw materials for the factory. The windows let the materials in through osmotic panes of glass. At a short distance from where the little rootlet cars stop, little Mr. Sap is busy at his job and drags the materials the rest of the way.

To make it more clear, let us watch Mr. Sap. He rushes to the cars for he can see them full of raw materials. He opens his arms and takes them from the cars. Now he has quite a heavy bundle, so it will take him some time to travel. He drags the materials through the long tunnels, the roots, until he reaches the end, which is at the base of the tree. Then Miss Tree sees him and sends the elevator down through the sap wood of the trunk shaft. Mr. Sap hops on, delighted to be lifted with his burden. Up goes the elevator, to the factory doors, the ends of the branches. Then Mr. Sap

again drags them through the vein halls, leaving certain amounts at each door. There are two kinds of doors, entrance doors and exit doors. Through the entrance doors go the raw materials and they are situated on the upper and middle part of the factory while the stoma, or exit door, are on the under side of the factory and hidden with shrubbery composed of fine hairs. Through these doors the waste oxygen passes out.

Now, there are other products or materials made after the starch. These are sugars, cork and certain kinds of oils. Miss Tree knows that she can not store the sugars away, because certain bad roving boys, called yeast cells, sneak in and eat up all the sugar and disturb the factory. She can store the cork, which she does by lining the trunk elevator shaft. The oils she saves to give to her little seed babies and some starch too.

Would you like to hear more about these seed babies? In late spring Miss Maple Tree sends out wedding invitations to the wind and the insects to attend the marriage of each one of her pistillate flowers to her pollen bearing blossoms. In late summer and early autumn, before the autumn ball begins, little seed babies begin to appear with dainty little frail green wings. They hug their mother

tree tenderly for a long time. As they get older, Grandmother Nature whispers to them, that it is time for them to say good-bye to their Mother. They obey, and tearing away from Mother Maple, they fly off on the back of Mr. Wind.

After traveling long distances, they become tired and drop to the earth. They have been told by Mother Maple never to be lazy. They remember this and immediately start to build their subways and elevator, and some of them will grow big enough so that they too, can attend



the autumn ball, to which their Mother goes every year.

# THE NATURE-STUDY REVIEW

DEVOTED PRIMARILY TO ALL SCIENTIFIC STUDIES OF NATURE IN  
ELEMENTARY SCHOOLS

Published monthly, except June, July and August. Subscription price, including membership in the American Nature Study Society, \$1.00 per year (nine issues). Canadian postage, 10 cents extra; foreign postage, 25 cents extra.

**Important** Please note date of expiration of your subscription on the label of the wrapper. Subscriptions must be paid in advance to comply with postal requirements. Subscriptions and advertisements should be sent to *The Comstock Publishing Co., Ithaca, N. N.* Manuscripts for Publication and Books to be Revised should be sent to the Editor.

---

## Editorial

### COMPANIONABLE TREES

More people than speak about it have found companionship in trees, and have formed special relationships with individual trees. Well, why not? A tree is a living being in a measure like ourselves, as Bryant has so fully expressed.

One of the chief attractions of a tree as a friend is that we always know where to find it. Through winter and summer, year in and year out, it stands steadfast and ready to greet us, always attuned to our own mood. Of course we do not know in what regard the tree holds us, there being as yet no developed science of tree psychology, but this is a matter of no special importance. It is far more important to us that we give love and companionship ungrudgingly than that we demand these in return, measure for measure. It is petty business, being calculating in ones relations, either with folks or with trees.

In childhood, certain trees played an important part in our daily life. We remember distinctly one warm day in very early spring, when the mosses were green and the scarlet berries of the *Mitchella* glowed against their verdant vine background, that in the ecstasy of spring happiness and the renewing of old acquaintance, we forgot our Quaker training of composed demeanor and flung glad arms as far as they would reach around the trunk of a great forest grown maple and kissed its unresponsive bark, and then stood back abashed at what seemed a silly act. That maple had giant roots curled chair-wise at the base of its majestic gray bole and it had always seemed a loving motherly tree to the child, who grew up so

impressed with the individuality of trees, that it seemed too commonplace a fact to mention.

Many poets have felt this companionship with trees and perhaps none have expressed it more exquisitely than Lowell in *Under the Willows*. But the Editor had an inner conviction that this feeling is by no means limited to poets and so was led to ask several people, among them some very "level-headed" unsentimental and practical young men, to tell the truth about their experiences with individual trees. Some of the results of this request give special quality to this number of the REVIEW and there are others just as good, retained in the Editorial portfolio. These experiences have been published in THE REVIEW with a purpose, hoping that they will lead teachers to sympathetically help their pupils to what should be an inalienable heritage of the American child,—a sense of companionship with trees.

---

#### WELCOME HOME

"In time of war, one who loves his country should be at home." These are the words that came in a letter in May from Professor L. H. Bailey, the President of the American Nature-Study Society, who was in China when the United States declared war. And, true to his sentiments as thus expressed, he has cut short his stay in the Orient, and has returned to us and to any form of service which he can render his country in her time of stress.

It is difficult to express in mere words the rejoicing and the welcome from every side which have greeted him and his family on their return home. It is a source of cheer and comfort to us all to have them back to give us courage, to share with us, and help us to bear all that is coming to us, because of this war. Meanwhile and quite inevitably, the President of our Society has returned full of strange and interesting experiences which he gained while collecting plants in remote regions. Fortunately for the world, his interests are deeply human and, although collecting plants, he is always studying people and meeting them with gentle, keen and sympathetic understanding.

## The Teacher's Corner

### A Graded Course in Tree Study

¶ *Kindergarten First and Second Grades.*—The objects to be achieved in the kindergarten and the first grade are to make the pupils acquainted with the leaves of our more common trees and to make them interested in one or two individual trees and what happens to these trees each season of the year.

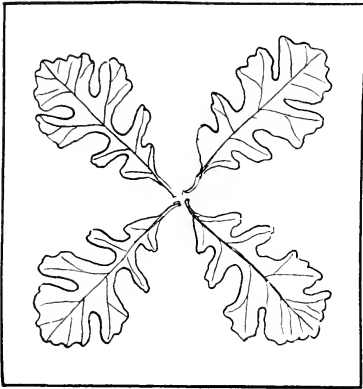

Leaves of mossy cup oak  
mounted on card

To accomplish these objects we use various devices and methods and the following suggestions will be found useful.

Let the children bring to school leaves of all sorts, which have autumn tints. They will be especially interested in picking up the bright colored leaves that fall from the roadside trees.

Let them classify the leaves according to color so as to train the eye to discriminate the tints and color values.

Let them classify leaves according to form, selecting those which resemble each other.

Have them tell in what respects they resemble each other, in this way incidentally calling attention to the margins, the veins and the petiole.

Teach the names of the leaves of the most common trees by mentioning *quite incidentally* that certain noticeable leaves are maple or oak or elm, etc. The children will quickly pick up these names by themselves if thus taught, and the knowledge will help them later on.

Let each child select a leaf of his own choosing and draw it. This may be done by placing the leaf flat on paper and tracing its outline with a pencil, later drawing in the veins; or the drawing may be made with colored crayon free-hand. The pupils should be allowed to please themselves in this matter, as it is not a drawing lesson but a lesson to help remember form and color.

Let the pupils select paper of a color similar to the leaf and cut out the leaf from it during busy work.

Let each pupil select four leaves of maple or oak as nearly similar as possible and press them in his book, and later arrange and paste them on a card in some symmetrical design. This may be done while the leaves are fresh, and the card thus decorated may be pressed and thus preserved.

*Third Grade.*—The work for the third grade should be an October calendar with a leaf mounted and labeled for each school day of the month. The leaf may be pressed and mounted upon a card, or it may be traced in outline and colored in crayon or water color, or merely traced with the veins drawn in. If there are not thirty species of trees available about the schoolhouse, two leaves of the same species may be used. These two leaves may show a variety in coloring or they may offer a contrast in size and in form since no two leaves

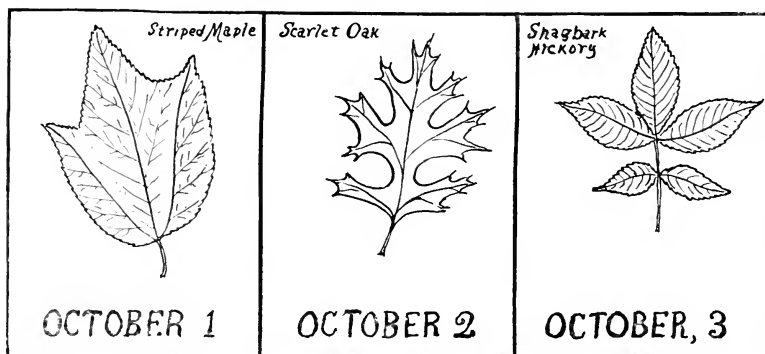

A Leaf Calendar for October

are exactly alike, and this in itself is a good lesson. The cards for the calendars should be of uniform size and if it is possible, the calendar should be made into a frieze and pinned to the walls. This will give the children an opportunity to study those leaves already used and will stimulate them to search for different kinds of leaves.

The learning of the names of trees should never be in the form of a task or a lesson but should always be given in the form of a game. For instance, after the children have traced many leaves put the drawings in a pile and then for busy work ask a child to go to the pile and pick out all the leaves of maple or poplar or sycamore in the pile.

Select some tree near the schoolyard which may be observed from a window, give it a name and try to impress upon the children that it is a living being in some measure like themselves. The following observations should be made at appropriate times during the year. The color of the tree during October, the shape of the tree with the leaves on, which should be shown in a sketch, any birds or animals or insects which may be found visiting the tree, the shadow cast by the tree and the kind of plants that grow beneath it, its fruits if they are ripe at this period.

In the winter the tree should be sketched again with especial attention to the shape of its trunk and branches. Note if the snow remains on the tree after it falls. In March bring in some twigs from the tree and put them in water and let the pupils see the young leaves burst the bud scales and expand. Later call their attention to the color of the young leaves and a sketch should be made of the tree in May when it is again in full leaf.

*Fourth Grade.*—In this grade the pupils should learn to distinguish the different kinds of maples, oaks, poplars, and pines which are common in the locality. This may be accomplished by a collection of leaves, each mounted on a card and labeled; in addition a specimen of the fruit should either be fastened to the card or sketched upon it.

In this grade the pupils should understand what is meant by a compound leaf which they will find on the hickories, horsechestnut, locusts, and ash. For the study of a compound leaf note the following: Of how many leaflets is



it composed; the shape of the leaflets; do the leaflets have petioles; are the edges of the leaflets toothed; which of the leaflets is the largest and which is the smallest; are the leaflets paired and opposite each other; are the leaves opposite each other on the twig or are they alternate?

For supplementary reading use the stories of famous trees.

*Fifth Grade.*—The pupils of this grade should be interested in the tree as a whole and perhaps there is no better way to accomplish this than making a

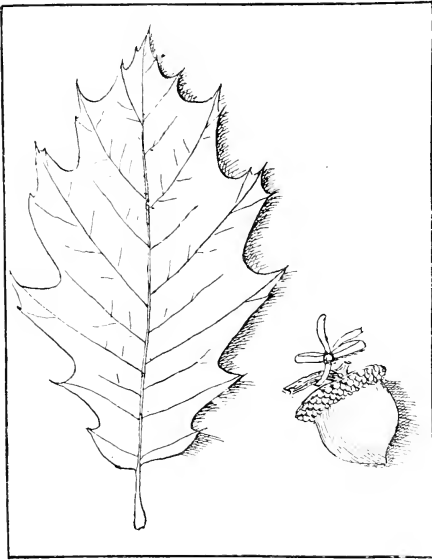

Leaf and acorn of red oak mounted on a card

card mount of a tree species which shall include a leaf, a blossom if possible, the fruit, a bit of the bark, a cross-section and a lengthwise section of the wood, and an account written of the tree, where found, for what used, etc. It takes some time to make such amount and each pupil should contribute one to the school exhibit; and while two may choose the same tree it is best to have as wide a representation of tree species as possible. An exhibit of this kind fastened to the walls of the room is of great interest to everybody and of very real educational value to the pupils.

Another way of securing a wide knowledge of trees is the making of a portfolio of leaf prints which is especially fitted for fifth grade work. See p. 295.

The pupils should learn about the life processes of a tree. The uses of its roots, trunk, branches, bark and leaves; how a tree grows; its food when found and how prepared; the movement of sap and transpiration; how it breathes and how it builds its rings of growth.

*Sixth Grade.*—This should include note book work on all the trees in the region. The note books may be those with formal outlines or may be purely individual books with sketches and original observations by the pupils, but in general the note book should include the following observations: (1) Where is the tree growing, was it planted by man or did it plant itself? If an isolated tree it should be sketched. (2) Does the bole or trunk extend straight up through the head or does it divide into many branches? (3) The character of the bark of the tree, especially noting whether the bark is smooth, scaly, rolled up, or divided by fissures, and note whether the ridges between the fissures are sharp, rounded, or flattened. Note especially the color of the bark. (4) Are the leaves placed opposite or alternate on the twigs; is the leaf simple or compound? Describe its appearance above and below. A sketch should be

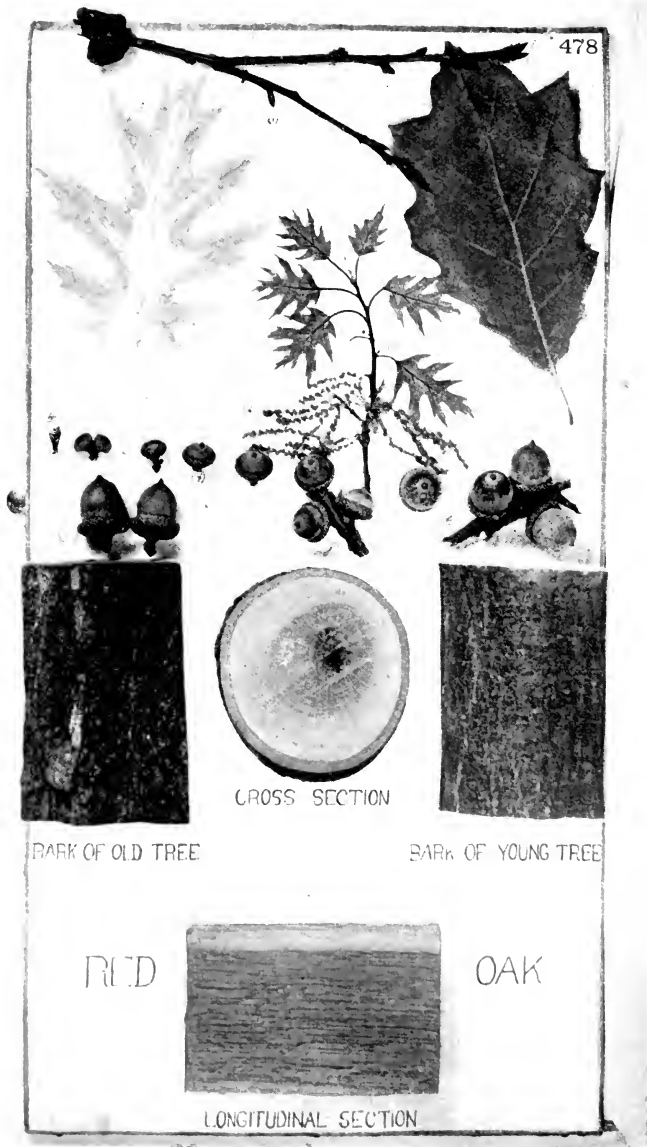

A prize mount illustrating the red oak, made in a rural school.

made of the leaf. (5) Describe the time of blossoming and the blossom if possible. (6) Describe and sketch the fruit and tell how it is distributed and planted. (7) In what ways is this tree used by man?

In sixth grade there should be a study of an apple tree and there should be practical demonstrations of grafting and budding, a study of the insects that attack it, and the methods of saving the fruit and the tree by spraying.

*Seventh and Eighth Grade.*—A study of the larger shrubs, especially those used in planting will interest the pupils of this age. A collection of leaf prints of the shrubs may be made. There should be a special study of park trees and extensive reading and writing in connection with these trees by describing the countries and the geographical distribution in these countries of the trees which we have imported; for instance, the Norway spruce which grows not only in Norway but in the Alps, etc.

A study of the evergreens of the section and the uses to which they are put will prove an interesting line of work.

A correlation of trees with history: Select some well grown tree in the neighborhood whose age may be fairly accurately ascertained and relate to it the events in the history of the town and the state. One of the most interesting exhibits ever sent to Cornell from a rural school was a cross section of a small tree which was about fifty years old. A pin was stuck in each ring of year's growth which also held a little label telling of some notable event in the town, the state, or the United States which occurred that special year.

A beginning of forestry may well be made in the eighth grade. There are several elementary books in forestry, notably *The First Book of Forestry*, by Roth, and the *The Book of Forestry* by Professor Moon, written especially for Boy Scouts; also access to the *American Forestry Magazine* will open up new and interesting and practical lines of work with trees.

---

#### AN EXAMINATION THAT IS A GAME

After the pupils have had enough practice in learning to identify leaves,—bring in a variety of leaves and label them by thrusting the petiole of each through a slit in a bit of paper, bearing a number; or by pinning the label bearing the number around the petiole; we must make sure to select several leaves of each species which will show variation in size and form. Supposing we take twenty-five leaves thus labeled,—ask each pupil to take a sheet of blank paper and place numbers up to twenty-five from top to bottom along the left margin. Then pass the leaves around and let the pupils write the name of each leaf opposite the number corresponding to that on its label. This is a most exciting game, and is a very efficacious method of teaching this subject.

Another similar game, is to equip each pupil with pencil and paper and take a short field trip; the teacher selects a tree and calls out, "This is number one," and then selects another and calls out, "This is number two," etc., and the pupils write down the name of the tree opposite the number on their own paper.

## News Notes

### CALIFORNIA

The California Nature-Study League's *Story Service to the Libraries* of the state is helping the children to learn to "read a roadside as they would a book," by first calling their attention to the roadside and then directing them to the book. Below is a sample of a postcard, recently sent to all the Country Libraries, bearing the material of a newspaper clipping from the *Sacramento Bee*:

#### FINE EXAMPLE OF BUTTON WILLOW NOW IN SEED ON B STREET LEVEE CROSSING

Where the cross levee leaves the B street levee at Twenty-ninth street, there is in seed this week a fine example of Button Willow. Children *who learn to read a roadside as they would a book*, give this bush this name because of its willow-like leaves and the button-like fruit.

It is common along the stream banks in the Sacramento and San Joaquin Valleys. It is not a willow, but a member of the Madder family. It has about 4,500 "cousins" mostly in the steaming tropics. One of these cousins is the Chinconcha, from whose bark quinine is obtained. Another is the tree from which we obtain the coffee for our tables.

A third member of its family is the Madder, a plant of West Asia, which furnishes the dye called "Turkey Red."

#### BEDSTRAW ALSO COMMON

For centuries in India, before the English mills learned to copy the designs, bandana handkerchiefs were colored with this dye. Still another member of the family is the Bedstraw, a common plant in California, so named because the French peasants believed this was the plant that was used to fill the manger wherein the Christ-child lay.

Children wishing to know more about the Button Willow or the Bedstraw can obtain Miss Parson's books, *Wild Flowers of California*, also other nature study books from almost any branch of the various County Libraries throughout California.

### RHODE ISLAND

Arbor Day as celebrated last spring by the Rhode Island Normal School in Providence must have been a delight. Their program of *Field Day in Lincoln Woods* reads like one glorious frolic with a nature-study basis.

Preliminary talks had been given on The Class Tree, and The Class Flower, on the History and the Geology of Lincoln Woods, and each pupil had been presented with a map of the Woods with full directions regarding street cars and lunch.

The exercises were in the form of an Interclass Meet with events which were so full of nature-study that we print the whole outline:

#### INTERCLASS MEET, DESIGNED FOR ARBOR DAY

1. *The Hidden Trail*. Starter, Mr. Brown. Open to five delegates from each class. Party will leave base of operations by a zigzag route. Groups

will leave at five minute intervals, to return to starting place. Class returning by shortest route will receive 10 points. Other classes will receive 8, 6, 4, or 2 points according to way of returning. Captain of each party should have map and compass. Official Time Keeper, Miss Manchester.

2. *The Treasure Chest.* Mr. Wells. This will be hidden at a spot designated on the map. Open to five delegates from each class. No one is eligible who has ever lived in Pawtucket, Lincoln, or North Providence. Points granted on basis of 10.

3. *Flower Game.* Miss Weston. Each class to send five delegates. A definite time will be assigned for gathering flowers. Each group to take but one flower and that must be cut off with a *knife*. The number of points will be the number of flowers identified by the group.

4. *Tree Twigs.* Mr. Cotton. Five delegates from each class. Same rules as for the flower game.

5. *Insects, cocoons, mummy cases, or eggs.* Examiner, Mr. Tucker. Five delegates. Time limited. Half points given for the number collected; whole points for each kind identified.

6. *Edible Plants and Animals.* Miss King and Assistants. Five delegates. Time limited.

7. *Bird Recognition.* (Song, nest, or by sight.) Five delegates from each class. Time limited. 1 point for each bird agreed upon by group. Assemble as follows: Senior A, Mr. Vinal; Senior B, Miss Brown; Junior A, Mr. Tucker; Junior B, Miss Stillman; Junior C, Miss Weston.

8. *Smelling Game.* Miss Bird. Twigs and plants having a characteristic smell. One candidate from each class. Must be blind-folded during operation. 1 point for each object identified.

9. *Fire-makers.* Three delegates from each class. Scores will be based on time required to gather wood and boil water. The class finishing first obtains 10 points, second place 8, etc. For every extra match 1 point will be taken from the final score. Groups assemble at suitable places with the following leaders: Senior A, Mrs. Irons; Senior B, Miss Griswold, Junior A, Miss Patterson; Junior B, Miss Shaw; Junior C, Miss Makepeace.

10. *Question Game.* Dr. Carroll. Points given for each question answered. Open to all those not elected to special groups.

#### IOWA

The Califor Naturalist Club of Charles City has a most interesting program for the coming year. The October meeting is to be with Mrs. E. M. Sherman and "The Methods of Tree Budding and Grafting" and "The Economic Value of Iowa Grasses" are to be discussed by Mr. Patten and Mrs. Burns.

The Califor Club offers for sale, its first and second annual reports and Bulletin No. 1—all for seventy cents. This club is very much alive and we recommend other clubs to get in touch with it and its methods.

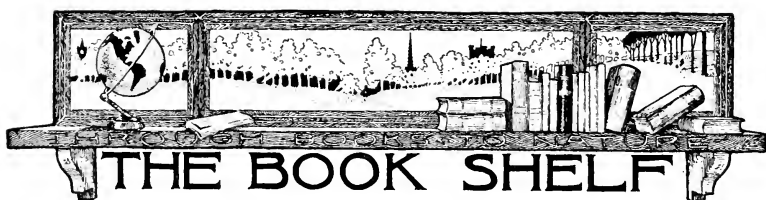

*Trees Worth Knowing.* Julia E. Rogers. 290 pp., 16 full page illustrations in color, 32 illustrations from photographs. Doubleday, Page & Co. Price \$1.60.

Tree lovers everywhere must always be glad when a tree book appears with Julia Rogers as author. This book tells about trees in a very practical and interesting manner, but is not a book for the identification of trees; it begins with a very clear and interesting chapter on *The Life of Trees*. No one has ever been able to put so clearly before the uninformed reader the life processes of a tree as has Miss Rogers, and this chapter is a good example of her ability as a teacher. The titles of the chapters show a very pleasing and interesting arrangement of the material. The accounts are succinct and filled with interesting information and are not confined to the trees of the East but include mesquite and other desert growth and the trees of the Pacific Coast. The several chapters discuss,—“The Nut Trees,” “Water-loving Trees,” “Trees with Showy Flowers and Fruits,” “Wild Relatives of our Orchard Trees,” “The Pod-bearing Trees,” “Deciduous Trees with Winged Seeds,” “The Cone-bearing Evergreens,” and “The Palms.”

*Old Crow Stories*, by Katharine B. Judson. 163 pp., with six illustrations. By Charles Livingston Bull. Little, Brown & Co. \$1.50.

This is a volume of nature myths that are of very first importance to the nature-study teacher, because they are the genuine folk tales about animals of the American Indians of the West. They are written in terse English very like the Indian language in its quality, and they are as interesting as they are naive and delightful. Miss Judson is an authority on these tales, for it is she who has preserved for us in most pleasing form *The Myths and Legends of the Mississippi Valley*, of the Great Plains, of Alaska, of the Pacific Northwest, and of the old Southwest, in as many volumes. *The Old Crow Stories* begin with the days when the Old Crow and Raven were white and before the light came. The first story is *How Raven Brought the Light*, then comes *The Thrilling Tale of How Grizzly Bear Stole the Light*, and how the Chipmunk got it back again, but the Grizzly Bear chased the Chipmunk who “scampered about until he saw a hole and made a straight line for it. But Grizzly Bear was so near that as Chipmunk dashed into the hole, Grizzly’s claw came down on his back and made four long scratches. That is how Chipmunk got the stripes on his back.” The other stories tell how Coyote and Grizzly divide their power and establish night and day. *How Sun was Made* and many other thrilling adventures of the Sun, and many fascinating tales of Coyote, the most cunning of all the animals. Through all the stories the conversations between Old

Crow and Raven act as introduction and commentary and add greatly to the interest. The illustrations by Mr. Bull are graphic and dramatic.

*Plant Materials of Decorative Gardening.* William Trelease, Professor of Botany, University of Illinois. Published by the author at Urbana, Ill. \$1.00.

This booklet of more than two hundred pages, in its most attractive and durable leather cover, is a miracle of compact information. Its first forty pages are given to keys for determining trees grown for groves, avenues, etc.; bushes used for shrubberies etc.; small undershrubs used for carpeting and woody climbers. The rest of the booklet is given to graphic, descriptive characterization of the different families, genera and species.

This book was built up from Dr. Trelease's own experience in teaching his pupils plant materials and surely no book that we have seen contains so much of such practical help as does this. Moreover, it is a book to slip into a pocket conveniently, and its weight is very small considering the vast amount of information which it contains.

*American Forestry.* An illustrated magazine about Forestry and kindred subjects, published each month by the American Forestry Association, price \$3.00 per year, address—Washington, D. C.

This periodical ought to be in every school in the United States. It is full of important and interesting information written by experts and the beautiful and edifying illustrations give it peculiar educational value. Everyone nowadays is interested in forestry, or should be, because of its vast importance to the welfare of our country, and I know of no other means of so surely interesting the pupils of sixth grade upward in this fundamental, necessary science, as the chance to look over and read articles in this magazine each month. It is also a great help in nature-study. Dr. Arthur A. Allen contributes regularly original and valuable articles on birds, illustrated with his own superb photographs. There are regularly two pages, *Forestry for Boys and Girls*, conducted by Professor Bristow Adams, who borders his pages with his own exquisite drawings and fills the pages with charming talk on very live topics.

*Tree Talk.* The Tree Talk Publishing Co., Stamford, Conn. Subscription price, \$1.00.

There are four issues each year of this excellent and enterprising periodical. It is given over primarily to the preservation of trees and especially to tree surgery. It is well illustrated, clearly written, and full of useful information about the care of trees. In every number there are articles of nature-study interest. For instance, the summer number of 1907 has a very interesting article on the willow weaving industry, also on the date palm, and notes on two famous trees by Katherine S. Nicholas, and illustrated,—one the Judgment Tree of Daniel Boone and the Wethersfield, Conn. Elm, which reaches the height of 110 feet and has a spread of 175. Charles Wesley preached under this elm in 1750. This magazine should be in the reading room of every school, also it will focus the pupils' attention upon what is necessary to preserve shade trees and orchard trees from their enemies, insects, fungi, and wind.

# THE TREE NOTEBOOK

ANNA BOTSFORD COMSTOCK

(from the Nature Notebook Series)

Outlines for tree study in the field, and leaf outlines of the following species are given to aid in identification: the Poplars, Willows, Birches, Maples, Oaks, Locusts, Ashes, Hickories, Evergreens and a number of the ornamental trees. A convenient map of the United States and Canada showing the Tree regions is printed on the front cover.

The Tree Notebook is very thorough in its methods and is an incentive to good tree study.

*Pocket Size 160 pages*

*Price 30c each*

Special prices for quantities

## The Comstock Publishing Co.

ITHACA, N. Y.

# The Guide to Nature

Edited by EDWARD F. BIGELOW

A Monthly Magazine from the Naturalist's Point of View.

An interchange of observations by students and lovers of nature.

*NATURE is good in the school, because it is good anywhere for all people.*

Subscription \$1 a year.

Four months' trial 25c.

Single copy 10c.

## THE AGASSIZ ASSOCIATION

ARCADIA

SOUND BEACH

CONNECTICUT

Kindly mention THE NATURE-STUDY REVIEW when replying to advertisements



# THE NATURE-STUDY REVIEW

---

VOL. 13

NOVEMBER, 1917

NO. 8

---

## The Brook

L. H. BAILEY

In the bottom of the valley is a brook that saunters between oozing banks. It falls over stones and dips under fences. It marks an open place on the face of the earth, and the trees and soft herbs bend their branches into the sunlight. The hang-bird swings her nest over it. Mossy logs are crumbling into it. There are still pools where the minnows play. The brook runs away and away into the forest. As a boy I explored it but never found its source. It came somewhere from the Beyond and its name is Mystery.

The mystery of this brook was its changing moods. It had its own way of recording the passing of the weeks and months. I remember never to have seen it twice in the same mood, nor to have got the same lesson from it on two successive days; yet, with all its variety, it always left that same feeling of mystery and that same vague longing to follow to its source and to know the great world that I was sure must lie beyond. I felt that the brook was greater and wiser than I. It became my teacher. I wondered how it knew when March came, and why its round of life recurred so regularly with the returning seasons. I remember that I was anxious for the spring to come, that I might see it again. I longed for the earthy smell when the snow settled away and left bare brown margins along its banks. I watched for the suckers that came up from the river to spawn. I made a note when the first frog peeped. I waited for the unfolding spray to soften the bare trunks. I watched the greening of the banks and looked eagerly for the bluebird when I heard his curling note somewhere high in the air.

Yet, with all my familiarity with this brook, I did not know it in the winter. Its pathway up into the winter woods was as unex-

\*From *The Nature-Study Idea*.

plored as the arctic regions. Somehow, it was not a brook in the winter time. It was merely a dreary waste, as cold and as forbidding as death. The winter was only a season of waiting, and spring was always late.

Many years have come and gone since then. My affection for the brook gave way to a study of plants and animals and stones. For years I was absorbed in phenomena. But now mere phenomena and things have slipped into a secondary place, and the old boyhood slowly reasserts itself. I am sure that I know the brook the better because I know more about the things that live in its little world; yet that same mystery pervades it and there is that same longing for the things that lie beyond. I remember that in the old days I did not mind the rain and the sleet when visiting the brook. I was not conscious that they were not a part of the brook itself. It was only when I began to dress up that the rain annoyed me. I must make a proper appearance before the world. From that time, the brook and I grew further apart. We are coming together again now. It is no misdemeanor to get wet if you feel that you are not spoiling your clothing. One's happiness is largely a question of clothes.

But the brook is one degree the better now just because it remains a brook all winter. The winter is the best season of the four because there is more mystery in it. Things are hidden; yet there is a new and strange spirit in the air. There are strange bird-calls in the depths of the still, white woods. There are strange marks in the new-fallen snow. There are soft noises when the snow drops from the trees. There are grotesque figures on the old fence. There is the warm brown pathway of the brook still winding up between oozing banks. In the spring there are troops of flower-gatherers along the brook. In the summer there are fishers at the deep pools. In the fall there are nut-gatherers and aimless wanderers. In the winter the brook and I are alone. We know.

In Nature's open book,  
An epic is the sea,  
A lyric is the brook:—  
Lyric's for me.

FRANK DEMPSTER SHERMAN.





EAST



grain field

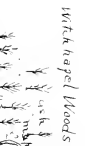

maples green meadow

level fields

HERMIT THRUSH  
BROOK  
MARTHA QUICK

North  
rolling knolls



golg links



KEY

- Swamp
- Trees
- Bushes
- Falls
- Rocks

South





The Brook flows leisurely through the woods, loitering in the sunny spots as if loath to leave.

## Hermit Thrush Brook

MARTHA QUICK

Among the slightly rolling meadows which lie northeast of Ithaca, a brook is born. It starts out upon its journey to the lake, fed by many cool springs which bubble up through the soft spots of the great crown swamp.

This swamp extends for about a mile, slightly bending toward the north. It becomes wider or narrower in certain places, bordered on either side by fertile fields which gently over-shadow and feed it.

The swamp was once filled with many large trees. These have fallen at various places, while others, decayed or dead, stand like sentinels on guard. A second growth of small pines, hickories, elm and cherry help to give a pleasant shade, while along the edges, like a neat border is a thickly grown hedgerow of elm, ash and ironwood with plenty of wild cherry to fill up the spaces. All kinds of swamp loving plants grow here. Sedges, cattails and hellebore form the bright, green covering while marsh marigolds and other smaller flowers lend it glowing color. Hundreds of shy and beautiful

birds here form an orchestra. The limpid notes of the white crowned and white throated sparrows are blended with the louder, searching songs of the orioles and grosbeaks. Thus with the sweetest music, the waters of the brook awake and ooze slowly out of their swamp cradle. Then they are caught together by a narrower passageway and begin their journey; they cut their way through the soft muddy earth of the meadow, crossed by the road and then begin to show the character of a stream. At first the banks are muddy and tender, the brook flows slowly winding and curving this way or that. It soon forms a wide curve, past the edge of open wood, where large white pines, maples, scarlet and white oaks form a partial curtain overhead. While along the edges and in open places the witchhazel, cedar and hawthorn grow. All the wild flowers of the wood, hepatica, violet, adder's tongue, trillium and squirrel's corn form a gorgeous carpet for this woodland. Close by the side of the brook the pussy willow bends, and the quaking aspen stands above. The brook trickles along the side of the wood, curling slowly to the south then meanders with many a curve and recurve through the moist and deeper wood.

Here in the denser shade of the bush, the hermit thrush is seen. Many other of nature's best songsters are singing here and as if inspired by music the brook begins to utter soft gurgling notes. At the edge of the woods an old pine stump-fence crosses its path and makes it flow deeper but more slowly.

A Marsh hawk rises from an inlet of swamp at the corner of the woods, where the brook receives a companion flowing from the north, and thus strengthened, straight toward the northwest it steers its course, across the lower center of the meadow. The sides of the meadow rise more steeply here and show that the brook once flowed through a thicket of wild cherry, teasel and small trees; now all is cleared away to make more soil for the farmer, and only a tall shagbark guards the south bank with smaller elms and maples on the north.

Here the water washes over pebbles of the glacial period gathering much sand from its grassy banks. Where the meadow becomes nearly level, the stream does not keep its close channel but widens out into many small rivulets again uniting after a distance of a few rods where it is made stronger by a branch flowing from the woods at the north.



The brook then flows across the meadow through an old stone sluice under the Kline Road, then turns its course to the southwest traversing a pasture. It now passes the edge of another woodlot with many young willows fringing its route. During the course it gathers much speed and comes bounding out again into a narrow valley, which leads directly toward the west.

This valley is bordered on either side by woods filled with huge old trees. Plenty of red oak, basswood and maple form the cover, while blue beech, hawthorn and small elms make up the second growth. The brook flows slowly and leisurely through the woods, loitering in the sunny spots as if loth to leave. When it flows out into the meadows again, it finds new surroundings. It has now become an educated brook flowing beside the garden plots and lawns of pleasing residences. Here it is enshrined and places of beauty, along its banks are designed as resting places. A dam has been made where the children may play, but the waters hasten ever onward.

Here the stream cuts its way through grassy fields, whose clay-like soil it sweeps along, but it does not linger in these surroundings, but hastens faster and faster toward the brow of the hill. The bed rock now forms layers over which the water leaps and it seems hurrying on its way to the lake as it slides over the smooth rocky bottom. The banks become higher here as the stream begins the descent of the hill.

Now our brook turns hermit and is almost hidden by the second growth of wild cherry, hickory and maple. Every three or four rods it disappears for an instant in the cement culverts, which conduct it safely under the roads. It gains more speed with every little fall and sliding cascade; the bank becomes still deeper and now the brook sings its first real song of rushing water as it rushes over rocks and finer pebbles on its way through the woods.

In the deeper shade of this woods some of the rarest wildflowers grow. Columbine and moss pink adorn the rocks and the wild azalia sheds here its fragrance. The birds too accompany the stream with their glad songs. Just at the edge of the deeper wood, the brook takes its final and greatest fall into a deep gorge. This descent is over a rocky ledge perhaps thirty feet high. Many trees and bushes overshadow the fall from above. Only the roar and splash of the water as it drops into a deeper pool at the bottom of the gorge. This gorge extends for about an eighth of a mile.

gradually growing deeper, leading straight toward the west. Its steep rocky sides are covered with large trees while ferns, moss and wintergreen grow along the edges. Dead trees have fallen across it and a great old sycamore rises from the seemingly insecure base of a small island. Underbrush and debris make this part of the brook look rather wild, and it now excitedly sings its loudest song as if to tell the lake of its coming. Soon the gorge widens, growing more shallow, and the brook slips out into the sunlight again. The banks become widened the brook more shallow and the bottom more sandy. Soon it takes its last winding curve, looking back toward the gorge which it has left, and sinks gently down among the willows and coarse grasses of Renwick marsh.

The waters of the marsh enfold the little traveler and the brook is lost to view. Now it oozes through a swamp far different from the one in which it had its source. After its waters have been scattered and spread in all directions they are carried into the lake along with countless other waters. There the lake holds them as they still sparkle and dance, remembering their journey of miles down five hundred feet from the Crown Swamp, far in the east.



The Class Studying Hermit Thrush Brook where it traverses a pasture.

## Hermit Thrush Brook—A Nature-Study Rubaiyat

WILLIAM PRINDLE ALEXANDER

I

On Eastern uplands, sweet with vernal green,  
Our brook is born, amid a peaceful scene  
And its bright waters noiseless greet the day  
To dream awhile in loveliness serene.

II

New flecked with verdure, ranks of Alder stand  
Along the marsh, in sweeping beauty planned,  
Wherein our brooklet laves the marigold  
That stands reflected in a fairyland.

III

Above the marsh a thousand tongues are stirred  
In chorus, and soft melody is heard  
Among the alders, varied, rich and strong,  
As ever issued from the throat of bird.

IV

The while our brook in dancing allegro  
A lusty stripling, narrow in its flow  
Leaves marsh and bird, and marigold behind  
And cares not how, or whither it may go.

V

Swirling a song of wanderlust and joy  
Its merry rills through mead and wood deploy  
Kissing the lush reed, and the fragrant mint  
In passing, glad as butterfly or boy.

VI

And now it enters with auspicious sweep  
Witch-hazel wood, arousing from the sleep  
Of winter, and its banks with emerald moss  
Are decked like prayer-rugs, soft and ankle-deep.

VII

There in the wood hepaticas abound  
Sweet woodland sylphs, in lovely garments gowned,  
With many another elf of early Spring,  
That sway in gladness to the waters sound.

VIII

Out! On! Beyond! Through meadows rolling wide,  
In gentle swiftness, into realms untried,  
Feeling the lure of the great lake afar  
Into whose bosom soon our brook will glide.

## IX

Under the stone arch, close beside the farm  
 It silent steals, in cautious, still alarm  
 And then away, in placid solitude  
 Renews its crystal, marsh-born, wayward charm.

## X

Off to the woodland, with a steadfast aim  
 It flows—the wood that gave our brook its name  
 Will lend it beauty and a sylvan smile,  
 More fair than that sweet marsh from whence it came.

## XI

Then meet the rill, your little brother stream  
 And on together through the valley gleam,  
 Two crystal gems, merged in a widening course  
 Bright as a playful, iridescent dream.

## XII

Through Red Oak Wood, and o'er the level mead  
 Now suavely tame, and now with madcap speed,  
 By lawn and mansion, and great thoroughfare  
 It bravely bounds, where e'er its course may lead.

## XIII

Into the wood that mounts the rugged hill,  
 Through deepening gorge, the bounding waters spill,  
 In many a splashy, musical cascade  
 Or modulation, petulantly shrill.

## XIV

Then with a bound of beauteous overflow,  
 Into a gulf the crystal fragments go,  
 And lo! Taughannock, all in miniature  
 Is recreated like a cameo!

## XV

Down, down and down, to where the little cave  
 Is fashioned by your ever wearing wave,  
 And where the cat-bird loves to sit and sing  
 Let your sweet water for a moment lave.

## XVI

Out then, and slow, across the lowlands take  
 Your flowery way, through reed, and rush and brake,  
 Lingering songless, till with impulse strong  
 Your last full swirl is outward to the lake.

## XVII

Until Cayuga, like a mother greet  
 Her wayward boy, that comes with hastening feet,  
 When evening falls, and knows that there alone  
 Is rest for him, and happiness complete!

## The Brook I Found When on the Trail of the Wild Flowers

LUCY L. STRATTON  
Erie, Pa.



Y reminiscences of that first spring of wild flower hunting are tinged with a very tender affection for that *Brook*, indeed we became fast friends for life, for to fancy the brook not requiting my love were impossible. Once to be sure—but that was not the fault of the brook—if on one occasion I lost my poise and fell in heels over head till my nose touched the sandy bottom, it just smiled a sunny smile, knowing I was not harmed, and turning and looking back from a big rock it met just below, it said laughing out loud but kindly—“Good for you!” The brook was not so very young even at the top of the wild glen where it jumped over rocks and frisked like a wild school boy—it was born some three or four miles away, was of noble birth, its mother a very well-bred lake, a fair sheet I know not how large, surrounded by green meadows and fringed with willows. She would have been surprised methinks, that staid and placid mother, to have seen the mad antics of her offspring when it encountered that steep and rocky ravine. But nothing could be lovelier than its conduct in the many little grottos it found on its way through the meadows. How still it kept to let the pretty white stemmed birches whose branches arched above it and the ferns that drooped till they touched the water see themselves in its golden mirror! How tenderly it returned the greeting of the blue forget-me-nots on its banks bending down for a kiss! But for capriciousness there never was anything like it. In two minutes after dreaming so pensively and making love so sweetly in those sunflecked grottos we would see it tearing away again in the wildest kind of a frolic, running around rocks or leaping over them, elbowing saucily the big plants aside or dashing water all over them and so plunge along till it was tired and then another grotto—but never two in the least alike—always a new picture, one more lovely than another.



The Beaver Dam. For height compare with canoe which is on the edge of the dam

## Some Brook-Loving Architects

HARRY G. BULL, M.D.

This is a story of how some furry pioneers found a quiet place in the Canadian woods and decided to settle down and keep house there. A little brook ran out of one of the clearest and cleanest lakes you ever saw. Along its banks grew poplar trees and birches, both soft wood; and as their teeth serve these pioneers for saw and axe, soft wood is the best kind for them to use. In the hot summer months when the lakes get low their outlets get lower and sometimes dry up; that is one reason why the dams are called for; another reason comes with the cold winters, when little streams are frozen to the bottom and animals who live a large part of their lives in the water find this rather inconvenient. By building a dam, you see, they raise the level of the water so high that it cannot freeze to the bottom even when the mercury is forty below zero. Here, then, was a secluded place, off the beaten track of tourist and hunter. Tall cliffs rose a little distance from the stream, and everywhere were woods of birch and evergreen.

The beaver is a funny fellow. Imagine a woodchuck about the size of a half-grown collie dog, with a wide, flat tail covered with

leather, and you have a fair picture of him. His short feet are webbed for swimming and his teeth look like those of mice, but are large and strong. He stands against a tree on his hind legs when cutting it down, pushes a log ahead of him when swimming, and when carrying one on shore he holds it under his chin. Mud he carries on his nose, and some people say also on the flat tail. And this is the four-legged architect who builds lodges for a family of six or seven, and dams as long as a house and higher than a man's head.

Many generations of beavers have passed since the little stream was first backed up. Since then the water must have covered the first homestead, and the next, and the next, as the dam grew higher and the lake deeper. If we could walk along the bottom I think we should find the stumps of the first trees that were cut down and the remains of the old lodges. Our story will tell of the lake as it now is, of the dams that formed it, and of the houses where the builders now live.

Between the Beaver pond and the lake from which it takes its water is a series of little waterfalls, and an old lumberchute. The water looks black because of the dead trees that are in it. All along its edge stand the bodies of hemlocks and pines, drowned by the rising water and bleached white by the sunshine of many years. The pond is a regular flower garden, and white water lilies float silently on its black surface. Small islands of rotted moss float here and there; it is on a bigger island of this same moss—sphagnum, it is called—that the beaver lodges are built. At the outlet is a big granite rock, covered partially with trees and bushes. On each side of this is a dam about thirty feet long, and as the water from the two sides unites into one stream a little farther down, it forms an island.

Look at the picture and you can see for yourself how the dam slants backward from its base, how the sticks are laid together with moss chinked in between, and how the upper ones project above the level of the water. Compare the dam with the canoe at its top, and you can see how high it is. And all this was made by small animals, their only tools a pair of sharp gnawing teeth! They kept the bark for food, storing some of it away for winter, and used the bare sticks to build their dam.

Over to one side of the pond are the houses, looking like a wood-pile among the low, thick plants that crowd upon the moss island.

Look at another picture and see the two little waterways that the beavers have cut out as canals to the houses. They are only about two feet wide, so we can just nose the canoe up into them. Perhaps, by going very quietly, you think, we can get a glimpse of the tenants. Oh foolish fancy! If the last beaver had been one of those whose houses lie on the lake's muddy bottom the place could not appear more devoid of animal life. Go as many times as you will, and as quietly as Silence herself, you will see no sign of Mr. Beaver until you call in the evening. Where is he, then? I can't tell you; most likely asleep at home. But he is up and away long before you have looked through his roof, and as his front door is under water you do not see him leave.

Come some evening along towards dusk and quietly pitch camp nearby, invisible and unheard, and you will see this city of silence converted into a city of weird sound. At about eight o'clock the first loud slap of a broad flat tail on the water will announce the arrival of the working-hour, and from then until the first streaks of daylight come you will hear the sound of gnawing teeth on bark, the slap! slap! of tails, and the heavy splash of a laborer entering the water. At times the place seems full of them, and then will come a long period of silence, broken only by trickling water, that low, monotonous gnawing, and perhaps an owl barking, or a song-bird talking dreamily in his sleep. If the moon is shining,—or even by starlight with keen eyes—you may perceive a dark form pushing an arrowy path across the inky surface of the water, and you may hear the gentle lapping as the little swell rolls along the rock at your feet. Tear away a part of their dam before night falls, and perhaps the rushing water, warning them of a leak in their wooden wall, will bring them in a hurry to repair it. One night I came and watched at the broken dam, but was disappointed; they had very sensibly decided to first repair their roof, which my disrespectful curiosity had torn open.

So it is an apparently deserted village that we see as we disembark and pull the canoe up onto the springy island. The moss is ankle deep. As you walk upon it it sinks down before you and rises up behind and the circular waves travel along the whole mass and continue out upon the water beyond.

Two of the lodges are very good ones and in excellent condition. Over at the farther edge of the island is another one, smaller, deserted, and with roof caved in. Near the edge of the island and



opposite from this house is a pile of sticks beneath the water, built up from the bottom of the pond. This may be an abandoned foundation, but I doubt it; it is more likely a store for winter, for the beaver is a provident fellow and gets his stock in early.

I am going to describe only one of the houses as they were all very much alike in every respect. It looks at first glance like a pile of wood all thrown together in a disorderly heap. It is circular at the base, about seven feet in diameter, and about three feet above the base at its highest point, which is the middle of the roof. The sticks are not laid together in any apparent order, but are so crossed and chinked with moss and mud as to make a very strong structure. If in the building of it, a stick projects too far in to the interior it is simply gnawed off from inside. One day I took a party of seven boys from camp to visit the beaver colony, and all eight of us stood together on the roof; our combined energies in springing up and down resulted only in making it "give" ever so little.



The beaver houses and the water garden

Surely, you would think, the roof must be very thick! Well, let us see.

Without much difficulty I tore out a few sticks and some moss and mud, and to my great surprise found that the wall was only about six or eight inches thick! Inside was a single room. About half the floor was occupied with a sort of platform at the water level, where were the crumbs of the last lunch, a few silky shreds of white birch bark. Perhaps we interrupted the maid in her work; few of them would stop for a few crumbs with the roof being torn away above them! The edge of this platform went down a sudden step for about a foot, and then another deeper step down to where the entrance must have been. This is indeed a dark house, especially in winter, when thick ice covers the ponds. And crowded quarters it must be too, for a family of five or six. If they spend the day in such darkness and come abroad mostly at

night it is small wonder that daylight visitors find them so unsociable.

It is strange, this instinct of building. The caterpillar that weaves a silken shroud about him and lies down to undergo mysterious changes that bring him forth again an altogether different being cannot be thought to reason out his destiny. But is it only blind instinct that impels the building of a dam which shall lock up a small stream, and by making a deeper body of water ensure protection from the icy prisons of winter; that selects a floating island in preference to a shore, because it will not freeze so far underneath? Is it only a blind impulse that teaches an animal to gnaw down a tree at the base in order to get for food the branches that are far out of his reach? If we were to find evidences of these same activities in some prehistoric race of men, we would not think to call it instinct, but rather a high degree of reasoning.

---

## The Brook and I

"Throughout the year a brook is captivating. It is as companionable as a child, and as changeful. It hints at mysteries. But does it tell secrets other than its own? Does it tell where the wild things come down to drink? Does it tell where the birds take their baths, or where the choicest wild flowers lurk? I fain would know the story of its playfellows and dependents.

The brook has made its own way down the hill, through the woods and across the meadow. May we not follow it? Is it not a type of the best kind of human life?—the steep hillside of youth, the wild dash, the splashing through and under and between difficulties, the firm, steady flow down the gradual slope of middle age,—finally the safe and tranquil passing into the unknown?

And yet, in spite of its mysteries, one may really know a brook. A river is too distant,—too much an institution and too little an individual. A brook comes to play in one's yard. It is neighborly. It invites confidences. It reflects our smiles and our tears with the same calm surface.

Nor is the brook always idle. The brook practical may typify a more useful life than the brook romantic. It may be both. So, too, may we. If the stream goes on merrily below the mill, may not we, too, do an honest day's work and keep moderately cheerful? I would that I might be like a mountain brook, never stagnant, never vanquished by obstacles. That I might do my task and be ready to play when it is finished. That I might hurry through all uncleanness, absorbing none. And that I might give myself to the future with perfect confidence and peace."—MARY ROGERS MILLER (Preface to *The Brook*, Doubleday Page & Co.)



## How to Study a Brook

ANNA BOTSFORD COMSTOCK

When a geologist studies a brook he pays particular attention to the topography of the region which the brook drains, the area which the brook has eroded, the action of the water on the soil and the bed rock (what it uncovers and what it covers up), and finishes by observing the delta built up by this stream as it enters a pond or lake. When a zoologist studies the brook, he gives attention to all the animal life within the brook and near its margins. When the botanist studies the brook, he gives attention to the algæ and aquatic plants within the water, the plants on the banks of the stream and in the swamps formed by its waters, the trees that find nearness to the stream a congenial abiding place and the shrubs which live upon the banks. When the poet studies the brook, he gives attention to its sparkling waters, the play of sunshine on its swift currents, its sweet babbling or its angry roar, its mirrorlike pools which reflect the trees and the flowers growing on

its banks. In observing the brook from the nature-study standpoint we inevitably include all of these different kinds of observations and bring them together into a consistent whole.

In all the realms of nature, there is no other subject of study so varied and fascinating as is the brook. The study of it means hours out of doors amidst beautiful surroundings and with a theme for observation that grows evermore charming and engrossing. For many years the brook has been a source of keen enjoyment to the Cornell nature-study classes. The plan of work has been four fold: (1) a note-book filled with observations on the geologic characters of the brook, and both animal and plant life found in the brook and its environment. (2) The mapping of the stream indicating also the life about it. (3) The bringing together and recasting the notes from the note-book and map into a consistent story of this brook. Some of these stories are given in this number of *THE REVIEW*. So enthusiastic do the students become over this study that some have written their stories into poems, and some have illustrated their stories with photographs taken to show every new and striking phase of the brook's course and surroundings.

#### OUTLINE FOR NOTES ON THE GEOLOGIC ACTION OF THE BROOK

Does the brook have its source in a spring or swamp? Is this on the top of a hill, in a valley, in an open field or in the woods?

Has it banks at its beginning or is it level with the surrounding fields? Does it flow slowly or swiftly here?

Are the banks higher where the brook flows down hill? Is its course more nearly straight on a hill-side than on a level field?

Note where the water has cut the banks most deeply, why is this? Which holds the banks best, the roots of trees or the grass of meadows or planted crops?

Note how the bends in the brook are made; are they caused by obstacles or by the swift current digging into the bank?

Is the current swiftest at the middle or at the side of the stream? Which is the most rocky and pebbly, the bottom below the swift current or at the sides?

Is the bed of the brook more stony on the hillside or in a level area? Why?

Place a dam across a brook where the bottom is stony and note how soon the mud will cover the stones. Why is this? Can you find a pool in the brook that has not a muddy bottom?

Note all the signs in the brook and about it that shows the action of the water at flood.

If there is a swamp formed by the brook explain why it should occur at just this place.

If the brook empties into a pond or lake how does it make the waters of the latter look after a storm? Why?

What becomes of the soil carried down by the brook in flood time to the pond or lake? Do you know of any points of land extending into a lake or pond where a stream enters it? This is a stream delta, note how it was made.

Estimate the number of feet between the height of the brook's source and the level of pond or stream into which it empties.

#### OUTLINE FOR STUDYING THE PLANT LIFE OF A BROOK

What plants grow on the banks nearest the brook and what shrubs grow along its banks?

Note how the roots of these plants and shrubs prevent the banks from being washed out during floods.

Note the ferns and mosses that grow along the brookside.

What kind of vegetation is growing in the fields thru which the brook passes?

What kind of trees grow along the banks? Note especially and mark on the map all the trees that stand out alone near the brook. Also note if such trees have helped to hold the banks or change the course of the brook.

Are there water-weeds growing in the pools? Is there any moss or algæ growing on the rocks and stones underneath the water?

What plants do you find in the swampy places?

#### OUTLINE FOR STUDYING THE ANIMAL LIFE OF A BROOK

Are there cray-fish in the stream? Are they in still pools or in swift water? Note where they hide, how they walk and how they swim when frightened.

Are there any fish in the brook? Describe where each kind is found, in pools or in swift currents? Do they appear singly or in schools?

Are there caddis worms crawling on the bottom of pools? Of what materials are their cases made?

Note the dragon-fly and May-fly nymphs at the bottom of pools.

Are there any water-snails to be found? If so, on what are they feeding? Are there any tadpoles?

Note the whirligig beetles and the water-striders playing on the surface of pools. If the sun shines, note the shadows of the feet of the water-striders on the brook bottom.

Note and describe, where found and what any of the following animals were doing in the neighborhood of the brook: Frogs, toads, salamanders, snakes, turtles.

Are there any muskrats, mink, woodchucks, rabbits, raccoons, chipmunks or squirrels observed near the brook? Are the habitations of any of these to be found?

#### OUTLINE FOR STUDYING BROOK-LOVING BIRDS

Are there any water-birds on or near the brook? Are these wild or domesticated?

Note the swallows darting about over the pools. What kinds are they? Are there any nests of bank-swallows to be seen?

What birds do you find in the open fields thru which the brook flows? What kinds do you see in the woods above or near the brook?

What birds do you find in the swampy places? What ones do you see in the trees which stand isolated?

What birds' nests do you find near the brook?

---

### Making a Map of the Brook

This must, of course, be a crude attempt at map-making judged by engineering standards; but it is an effective method of opening the pupils' eyes to the course of the brook and the character of its banks and environment. The map should be made in sections on the pages of the note book, which later may be removed and pasted together.

The map shown in this number of *THE REVIEW* was made by a Rural School teacher who had never attempted to make a map from nature before. It shows only a section of the entire map.

## The American Larch or Tamarack, a Tree of the Swamps

JAY TRAVER

“Give me of your roots, O Tamarack!  
Of your fibrous roots, O Larch-tree!  
My canoe to bind together  
So to bind the ends together  
That the water may not enter,  
That the water may not wet me.  
And the larch with all its fibers  
Shivered in the air of morning,  
Touched his forehead with its tassels,  
Said with one long sigh of sorrow,  
Take them all, O Hiawatha.”

So sang the poet Longfellow in his beautiful poem of the American Indian as he used to be. We see at once from the dialogue above the usefulness of the larch-tree to the craftsman-ship of the Indians, especially in the manufacture of those wonderful canoes which could

“Float upon the water  
Like a yellow water-lily.”

Not only was the larch of importance to the Indians, but it is of great commercial importance at the present day. Its strong, fibrous wood is extremely valuable for the building of ships, railroad-ties and telegraph poles, and is quite extensively used for furniture, especially for beautiful cabinet work, for it may be polished very highly. The species which grows on the Apennines is quite remarkable for its ability to take a high polish. It is said that Raphael painted many of his earliest pictures on boards from the larch-tree. This tree is well adapted for strong, tall masts for ships; it is very durable, so much so that in certain old French castles the beams of this wood have been found to be intact after the stones around them had crumbled. Many old stories are in existence concerning the durability and the incombustibility of the wood of this tree. It is said that Julius Caesar when besieging a castle in the Alps, wished to set fire to a wooden tower in front of the gates. He heaped up logs of larch around it, but was absolutely unable to make them burn. He must have then been reminded that

“robusta larix igni impenetrabile lignum.”

Another quite different tale comes to us from Evelyn, one of the first Englishmen to write about trees, of a ship which was found

twelve fathoms under water in the Numidian Sea, having lain there fourteen thousand years. The timbers of the ship were of larch and yet these were still hard and sound even after that length of exposure. This tale may seem rather exaggerated, but we must at least agree to the extreme durability of the wood.

Besides its value as timber-wood, certain minor products of the larch deserve considerable mention. Turpentine and an extract of tannin are the most common of these, while the resinous exudation of the bark has been considered of medicinal value. One such medicinal product is oleoresin, usually spoken of as "Venice turpentine." A certain sweetish substance resembling dextrine is exuded from the bark of the western larch, and this the Indians used as food, having learned how to obtain it by wounding the tree.

The best place to find this interesting tree in its favorite haunts is in some mucky swamp, for, although the larch can and will grow on hillsides and in yards, it loves best to send its long slender roots far down into the yielding muck of the swamp. For this reason it is an important agent in the reclaiming of land from the water, since earth and vegetable matter become entangled in the roots and are held there, thus permitting the gradual filling up of the swamps and marshy places. It is often possible to push a pole down ten feet or more into the mud in which the larch has so firmly planted its feet.

Certain species, however, as the woolly larch are often found growing near the timber-line of mountains in Montana, Oregon, Alberta and British Columbia. Here the "tamarack is often found standing, a tiny tree, when its companion, the black spruce, is clinging to the ground, like a creeping plant, to escape being torn away by the force of the wind." This species is also called Lyall's larch, and mountain larch; the wood, which is reddish brown, has not yet become an article of commerce.

Our commonest form is the American larch or tamarack, also called hackatack, black larch and red larch. It occurs from Newfoundland to Alaska, and south to New York, Wisconsin and Minnesota. This species prefers swamps almost exclusively, and yet makes a very desirable tree for ornament if any larch is to be used, for its growth is rapid and it retains its symmetry of form longer than any other. This tree may attain a height of eighty feet.





The American Larch or Tamarack

A still taller species is the western larch, reaching up one hundred feet or more. It seems to be the largest of any of the larches, and is called the red American larch, the great western larch and the western tamarack. It occurs chiefly in the basin of the Columbia River. The wood of this species is a bright dark orange, takes a fine polish and is much used for furniture. The wood is the third heaviest of all coniferous trees, having a specific gravity of .74. Although it is the grandest of all the larches, it has not been cultivated in Europe, nor will it thrive in the eastern United States unless grafted on the root of some other species.

Julia Rogers tells us that there are six old-world species of the larch, and that the most beautiful for use in lawns is the Japanese larch which has pale blue-green white-hued leaves. It is cultivated to some extent in Europe as a timber-tree, and proves an admirable wind-break. It may be readily grown from the seed and easily transported. The Apennine species may grow to be over 120 feet in height.

The generic name *Larix* comes from the Celtic word *lar* meaning fat,—evidently given because of the resinous substance produced from the bark.

“All of the larches grow with straight, rather slender trunks which are covered with thick, rough, scaly or furrowed bark. The branches are slender, usually horizontal, but sometimes ascending. The branchlets are pendulous, slender, elongated. They are roughened by short, scaly budlike branches. The buds are small and covered by broad, shining, brown scales. These scales remain for a time, leaving ringlike scars at the base of the newly-formed twig. The flowers appear in May with the leaves. The staminate ones are borne on short, leafless lateral branchlets, somewhat oblong and short-stemmed—many spirally arranged short-stalked, two celled anthers, opening cross-wise or diagonally. The pistillate flowers are lateral, on leafy branchlets of the previous season. The base is surrounded by inner scales of buds, and a few spiral thin scales with two inverted ovules at the inner base. The bracts are paper-like, long-tipped, longer than the scales, and scarlet in color. The cones, which remain on all winter, are erect and rather small and short-stalked. At the base of each fertile scale are two nearly triangular seeds, rounded at the sides, light brown and rather shiny. Leaves are deciduous, and two resin ducts are located close to the epidermis.”

At one time, it was under consideration to introduce larches into the forests bordering the English lakes. Wordsworth was greatly disturbed at this idea, and expressed his feeling in "*A Description of the Scenery of the Lakes.*" declaring that it is impossible for trees which terminate in a spike, like the tamarack, to blend together,' and that if hundreds of thousands were added, the effect would be the same. He further says, "As a tree it is less than any other pleasing; its branches (for boughs it has none) have no variety in the youth of this tree, and little dignity even when it attains its full growth; leaves it cannot be said to have, consequently it affords neither shade nor shelter. In spring, the larch becomes green long before the native trees, and its green is so peculiar and vivid that, finding nothing to harmonize with it, wherever it comes forth a disagreeable spark is produced. In summer, when all other trees are in their pride, it is of a dingy lifeless hue; in autumn, of a spiritless unvaried yellow, and in winter it is still more lamentably distinguished from every other deciduous tree of the forest, for they seem only to sleep, but the larch appears absolutely dead."

However, we do not all hold the same opinion of the larch, as we may easily see by the following extract from Pankhurst:—"With its luxuriant and needle-like foliage and pendant branchlets, it is exceedingly effective in a dense cluster. While it suggests the spruce, it has none of its austerity.

The leaves, an inch long and slender as a needle, grow in dense clusters as in the cedars of Lebanon. Its deciduous growth and cone-bearing propensities, showing that it stands on the dividing line between two opposing orders of vegetation, give our anti-evolutionist friend another hard nut to crack. The vaporous, vivid green of a million-budded larch in spring is as beautiful in its way as the bluebirds earliest call, and with it, becomes one of the naturalist's memories and anticipations of that joyous season."

Bryant also loved the larch in spring, for he wrote:—

"I know where the young May violet grows,  
In its lone and lowly nook,  
On the mossy bank, where the larch-tree throws  
Its broad, dark bough in solemn repose,  
Far over the silent brook."

True it is that in the first gushing, vernal days, when the skies kiss the earth, the larches are sprinkled full of buds of rarest green"—a wondrous sight to see on an early spring morning. Surely we all love the beautiful larch in spring.

# Agricultural Nature-Study

A. W. NOLAN  
University of Illinois

## *Lesson Plans for the Grades*

If the teaching of nature study in the public schools be based upon the following principles, there can be no criticism of such work, either by the practical farmer or by the conservative educator.

1. Nature-study is a direct, observational study of the common things and processes of nature which touch human interests.
2. The aim of nature-study should be to give acquaintance with and interest in the common things of nature.
3. Nature-study should be differentiated from technical science.
4. Nature-study should be for the child and not for the adult.

With these principles in mind the writer will present a series of suggestive lesson plans in nature-study from the first to the fifth grades of the public school.

## *Grades I and II*

The natural response of children of these grades to phenomena of nature is, "What is it?" The aim of nature-study in these grades should therefore be to teach acquaintance with and interest in the common things and processes of nature in the environment of the child. Their contact with nature is wide and varied, and the school through nature-study should make them acquainted with the names of natural objects and arouse a permanent interest in nature.

### LESSON I

Title: Our Pets—The Dog.

Aim: To teach sympathetic interest in the dog.

Material: A live dog.

Subject-matter and method: Introductory talks about each child's dog. What kind of dog is this? How can you tell? Name other kinds.

What have you seen the dog do? What does the dog eat?

How does he get his food? Where does he sleep?

Why do we like dogs? How does he help us? How can we help him?

What harm do some dogs do? How can you tell a sick dog from a well dog? How many have ever seen a mad-dog?

Read some good dog story. (See Dog of Flanders.)  
Tell of Gentry's Dog Show.

### LESSON II

Title: Our Pets.—The Horse.

Aim: To increase sympathetic interest in the horse.

Material: A horse before the children.

Subject-matter and method: Introductory talks about horses the children may have at home.

What are the names of your horses?

What do you think of this horse?

What is this horse's name?

What does the horse like to do? What does he have to do?

What does the horse eat? How does he get his food?

What does the horse do for us? What can we do for the horse?

Many other interesting questions will come from the children.

Tell the children some good story of a horse.

### LESSON III

Title: The "Pussy Willows."

Aim: To arouse interest in, and to learn the ways of the "Pussy Willow."

Materials: Twigs of "Pussy Willows."

Subject-Matter and Methods:

1. As early in March as practical have the children gather twigs of as many kinds of willows as can be found. Put these in jars of water and place in warm sunny windows. The catkins will soon begin to push out of the bud scales and the process of flowering may be watched by the children.

2. For the particular lesson on the "Pussy Willow" have several specimens of fully opened catkins. Ask the children to tell what these are, leaves, fruit, a flower.

On what do they grow? Where does the tree grow?

Why are they called "Pussy Willows?"

Where were these flowers all winter?

What made them open now?

Do the leaves or the flowers of the willow open first?

Are all the "pussies" on your twig alike?

Talk about how they differ. How many on your twig?

What becomes of these flowers? (Help to make seeds.)

Why do you think they are pretty?

3. For busy work the teacher may have the children paste the catkins on cards or paper, drawing ears and tail to finish the "pussy." These may be drawn to represent kitties on a fence.

#### LESSON IV

Title: Early Wild Flowers.

Aim: To get acquainted with some early wild flowers.

Material: Bunches of Hepatica, Bloodroot, or any early wild flowers available.

Subject matter and method:

1. One excellent method in the study of wild flowers is to take a walk with the children if possible to some wild wood where the flowers grow, and here merely introduce the children to the flowers, calling them by name, and let the children gather them as they will in happy glee.

2. As a school room lesson we may take the hepatica as a type. With modifications and adaptations to suit the flower the teacher may use the following suggestions:

a. See that each child is provided with a blossom, leaves and roots if possible.

b. What are these flowers? Where did they grow? Why did they come so early in the spring? (Explain that the roots and buds find food enough stored to make a flower quickly.)

c. What is the color? Are they fragrant?

d. The colored petals of the flower are sometimes called *petals* and sometimes *sepals*. How many petals to your flower?

e. How could we have these flowers to see without going to the woods every time?

It would be well to encourage the children to have a corner of the home garden for wild flowers. A bed of wild flowers would be a good thing on the school grounds.

3. The children may draw the flowers and leaves of the plant and use water colors to good effect.

#### LESSON V

Title: Window Gardens.

Aim: To interest the children in window gardens and to raise some flowers and vegetables in the school room.

Materials: Window boxes or pots and seeds.

Subject-matter and methods:

The children will be interested in sowing seeds and in seeing them germinate, and the window garden affords opportunity to cultivate this interest in school.

1. Get some neat boxes, or earthen flower pots, fill them with good, rich, sandy loam soil and place in sunny windows.

2. At this season of the year sow tomato seed, cabbage seed and lettuce seed for vegetables, and morning glory, nasturtiums sweet peas, pansies or some other old fashioned flowers. Such plants as the tomatoes, and cabbage may later be transplanted in the home gardens. The class period of one day may be used in an exercise having the children help in preparing the soil, planting the seed, watering and placing the pots or boxes in the window.

## LESSON VI

Title: The Chick.

Aim: To learn interesting facts about chickens, and to deepen interest in them.

Material: Several or a single chick.

Subject-matter and method:

1. Bring a few little chicks in a cage before the class and let the children watch the action of the chickens as the lesson proceeds.

2. Ask introductory questions similar to these: Why do you like little chicks? Where did they come from? How did they get out of the egg? (See the little tooth on the tip of the upper part of the beak.) What good are the chickens to us?

3. Give some bread crumbs to the chicks and watch them eat. Do they chew their food? What do they eat? How does the chick drink? Why does it drink this way?

4. Where do the chicks sleep?

5. How does the hen call her chicks? How warn them of hawks? What notes do little chicks make?

6. Tell the children that the covering on the body is called "down." What becomes of the "down" as the chick grows older?

7. Name some of the things little chicks like to do.

8. What misfortune often happens to little chicks? How can we help the mother to raise them? Tell or bring out the fact that shrubs furnish good hiding places for hen and chicks; that little chicks should have fresh water to drink; that they should have clean dry coops; and that they need plenty of good food.

9. Ask the children to tell of any pet chickens they may have had.

## LESSON VII

Title: The Robin.

Aim: To arouse interest in the robin and teach interesting things about it.

Material: The robin in sight.

Subject-matter and method:

1. Take the class to the window or out in the yard and watch a robin for a few minutes. Ask all to sit down, then talk with the children about what they saw the robin doing.

2. Ask the following questions, to be answered from the children's observations:

(a) What colors have the robins?

(b) Did the robins spend the winter with us?

(c) At what time of day does the robin sing most?

(d) Does a robin run or hop or walk?

(3) Did you ever see a robin pull a worm from the ground?

Tell how the bird acts. What food does the robin eat?

(f) Why do you like the robin?

3. Have a robin's nest to show the class, if possible. Bring out facts about where the robins build their nests, the material from which it is made, and how we may help them in their work of next building, by supplying nesting places, mud, and lining materials for the birds to use.

4. Question about the number and color of robin's eggs. How do young robins differ from little chickens? What do robins feed their young? What are some enemies of the robin's nest and nestlings?

5. How does the robin help us? How can we help and protect it?

6. The children may make a little robin booklet, with drawings and the answers to some of the questions written out.

7. Tell the legends of how the robins got their redbreasts.

## LESSON VIII

Title: Pigeons.

Aim: To learn interesting facts about pigeons.

Material: Pigeons to observe.

Subject-matter and method:

1. If there are pigeons in the neighborhood, ask the children to observe them and report in class. Begin with some interesting



story about pigeons and a few questions which will arouse the children's interest in the birds. A pigeon in a cage before the class may be desirable.

2. Question the children's observations:
  - (a) Color of the pigeon you saw?
  - (b) What do pigeons feed upon?
  - (c) How does the pigeon drink?
  - (d) Do they sail through the air in flying, or constantly flap their wings?
  - (e) What sounds do pigeons make?
  - (f) Describe the nest, eggs, and young birds.
  - (g) How do parents feed their young, and on what material?
  - (h) Are pigeons of value to us? How?
  - (i) How can we help them in any way?
  - (j) Would pigeons make good pets?
  - (k) Where do they like to stay and nest?
3. Read to the pupils "Arnaux," in *Animal Heroes*.

#### LESSON IX

Title: The English Sparrow.

Aim: To teach interesting facts about the English sparrow.

Material: The birds for observation.

Subject-matter and method:

1. Let the pupils make their observations on the English sparrow about the homes or on the streets wherever they can find the birds.
2. Question observations:
  - (a) Are all the sparrows in the flock colored alike? Describe the colors. The ones with the black cravats are the cock sparrows, the ones less ornamented are the hen sparrows.
  - (b) What is the food of the English sparrow? Where do they find it?
  - (c) Are these sparrows kindly or quarrelsome?
  - (d) Do they go south or remain with us in winter?
  - (e) Where does this sparrow build its nest? Describe the nest.
  - (f) Are the English sparrows our friends or foes? Why?
  - (g) Tell why and how the English sparrows came to be here.
  - (h) Are there any successful ways to get rid of them?
3. Make it clear that there are many other kinds of sparrows, and that all the rest are good birds and should never be killed.

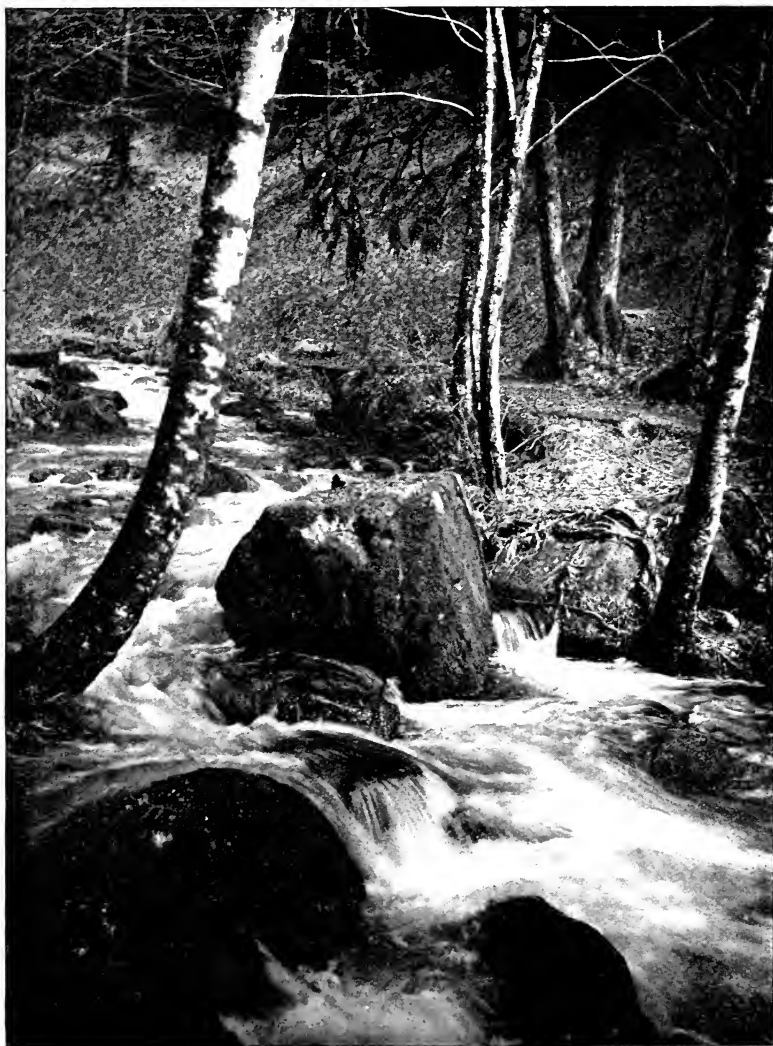

*Photo by S. J. Wigley*

The Brook is getting wider and occasionally there is a boulder in its bed.

## The Story of Vanishing Brook

MADLINE AVERY LIVERMORE

One would never guess, from visiting the source of our brook, that it had ever done a great work. No matter how tired you were, you would surely be rested after spending an hour or so by the side of this little brook. The whole atmosphere is so calm and peaceful, the sky is so blue and the grass so green.

There are two small branches which unite not far from their origin to form this stream. The left branch begins near a fence, with two wild cherry trees to mark its source. It is a sluggish little stream—with first a little pool, and then a tiny silver thread till it reaches another pool. It is doing practically no work now, but that it because its days of work are over. For the old banks are deeply cut, showing that one day this little stream was carrying a big load. The left bank is higher than the other. There are many big flat stones in the brook, and occasionally a little dam or a plank which show that the children play in it, and that grown folks cross it too.

There are grasshoppers and cabbage butterflies along the banks, water-striders in the water, and the air is full of the fragrance of apple blossoms from some nearby trees. Up in the very top of one of these trees is a bobolink calling to his mate.

The right branch has some apple trees to mark its source. This little stream does not flow thru comparatively level ground as the other one, but flows down a rather steep grade, and is still doing work in the spring, for there is a great deal of fresh erosion. This stream is not sluggish and marshy as the other. There are big flat stones here also. Some cows are grazing nearby, and just thinking of coming down for a drink.

After these little branches unite, the valley becomes more and more marshy, until the stream itself finally disappears almost entirely. And here we find cat-tails, with a red-winged blackbird swinging on the very top of one. At the right is a big lone pine, looking very picturesque against the sky. When the brook appears again it is for only a little ways, for it soon reaches another swamp and this time it is a big one just full of cat-tails, beset with skunk cabbage which is just unrolling its big leaves near the edges. At the left is a beautiful hawthorn all in bloom. The grass on the

banks is dotted with yellow dandelions which shine like little suns in the fresh green grass.

The valley gets wider and wider, until it occupies nearly the whole pasture. In the swamp here, are some cowslips, and near the edge a group of Mayapples, their little umbrellas protecting the buds, which are almost ready to open.

Gradually the swamp grows narrower. The little stream is meandering from one side to the other, so as to visit all the clumps of swamp grass and skunk-cabbage and sweet-flag and bid them "good luck." At the right two lovely willows are growing down near the water's edge, and a little below at the left, some more hawthorns all in blossom. The meadow on both sides is still dotted with dandelions and the air is filled with bees and butterflies, and the fragrance of spring.

Now the bank at the left has disappeared into a level meadow, and there is a woody bank at the right, where another lone pine stands out against the sky. Here the stream flows under a fence and a stile, and all of a sudden disappears ignominiously into a tile drain. Above the stream is a perfectly dry grassy meadow for a little way, and then from another tile opening a deep, clear brook with a gravelly bottom springs into existence, not very much like the little brook we've been studying. After a few minutes it again disappears under the road and comes out thru a big tile on the other side, a bigger brook than ever. There are steep banks on either side. The left one was probably washed out during the flood, because of the way the grass and stones look. The stream is gentle now, and tinkles along as merrily as can be, but it is plainly seen that the banks were flooded in the early spring. The bottom is muddy now, for the stream is not swift enough to take the silt with it, so it is dropped.

There are long-legged striders floating about on the surface and their feet cast snow shoe-shaped shadows on the brook bottom; and there is a green leopard frog the first one we've seen. But what is even more interesting are the little crayfishes crawling around on the bottom. Aren't they funny looking things? You wonder how they can keep all those legs and feelers and things going, at the same time.

There are black raspberries and also some wild grapes along the banks now, and the bottom is more grassy. On one side is some ribbon grass, and on the other a big sumach bush. Also there is

some "horse tail" which we haven't seen before. The stream seems to be a succession of little pools and rapids, once in awhile it comes to some big flat stones which it ripples gaily over, and then forms another pool.

Now there is a solid rock bottom, and lovely grassy banks on either side. A little farther on we see some algæ growing over the stones. The brook is getting wider and occasionally there is a boulder in its bed. Here are the first waterfalls we have seen; and now the stream bed must be twenty feet wide. There is a very steep bank on one side, and many big trees on the other. These trees are hickories and butternuts, also some choke cherry. In the tops of these trees are some goldfinches flying from branch to branch.

The steep bank is very rocky now, and covered with beautiful ferns, many of them the graceful bulb-bearing species. There are big trees on either side almost meeting overhead, and it is so cool and shady one wants to stay right here all the rest of the day. But we must go on and see what happens to the brook next, and get acquainted with some more of its neighbors.

The trees seem to grow taller and taller, and now they really do meet overhead. They are full of birds, whose notes sound very much like those of the oriole and the white throated sparrow. And there they are, both of them! Also in the top of one of those tall trees is a big squirrel's nest, and Mr. Squirrel is just coming out to see what is going on.

Here is a big culvert, below which the valley is wide, but there is little water and a good many big stones. There are piles of flood wood here which shows it must be a big stream in the spring. After flowing down grade for awhile there is another succession of still pools, completely shaded by the trees on either side. Here is a dam which some children have made, and I don't blame them for choosing this place in which to play. Here are overhanging banks with hawthorns and big elms with wild grapes climbing up their trunks.

Here is another culvert, and then a gorge, that must be as much as forty-five feet deep. The banks are very high, and covered with dead leaves and some ferns, and many big trees, making a dense shade which the ferns love; many of these trees are hemlocks. And who saw this Jack-in-the-pulpit?

Here are some fossils in this rock, which tell us that the place was once the bottom of the sea. Now the brook seems lost among lots

of great stones, no water in sight except for an occasional pool, which harbors some May-fly larvæ; and here are more lovely ferns protected by those big hemlocks. There is one tree which towers above all the others, and that is of course a white pine.

After another big culvert we come to a narrow dell. It is very deep, but not nearly as wide as the gorge has been. Along a little way, however, it widens again and is not so deep. There is first a tiny thread of silver at the bottom, our little brook again.

Now it flows under another road, below which we come to a big amphitheater at least fifty feet deep. Think of the work our little brook must have done some day, to carve out this big hollow! If there were any other possible way in which it might have been done, I'm afraid you might not believe me when I tell you that the brook did it all.

The water goes dashing down over the rocks over in the center of the gorge, and forms some waterfalls nearby, thirty feet high, and then settles calmly into a great dam; but when it escapes from the dam it dashes down into another deep and narrow gorge. It must be one hundred and fifty feet deep here, the very deepest we have found yet.

But soon we come to a wide open valley, with a steep bank on one side, and the other side is very level. All of a sudden what happens to the brook? Yes it has disappeared! Where has it gone? Under the ground of course; out of sight down in the gravel finding many secret passages it finally reaches the lagoon and the lake.

Do you think there was ever a brook which had more things happen to it, or which had nicer neighbors than this one has?

---

Thou hastenest down between the hills to meet me at the road,  
The secret scarcely lispings of thy beautiful abode  
Among the pines and mosses of yonder shadowy height,  
Where thou dost sparkle into song, and fill the woods with light.

But not the white wake-robin, nor the star-flower on thy brink,  
Nor any forest-shrub whose roots from thee refreshment drink,  
Can need thee with my need, Friend Brook; and never any bird  
Can thrill such gratitude to thee as my heart chants, unheard.

LUCY LARCOM—*from "Friend Brook."*

## Glenwood Brook

STEWART H. BURNHAM

Hudson Falls, N. Y.

The night of Christmas day,—a heavy rain lowers the heavy snowfall of preceding days. Going farther than the wood's margin, I see where the Cottontail came out of one den, made a half dozen steps and then into another; evidently liking not the rain and leaving dirty tracks on the snow. The water from the pasture pondholes flows down into the sinkhole—a musical stream.

In the hemlock dell, Glenwood brook flows fullbanked and I may not cross it even if I wished. Up in the woods so serene,—the pretty, small hemlocks still laden with snow! the Glenwood cascade so musical! the leaning yellow birch with its curling bark and old seed catkins!

In the brook frozen in the ice, when the water runs over the ice, little sticks sway back and forth merrily and a leaf attached to a bending twig touches the flowing water and rocks and rocks.

It is a fairy vision—so beautifully dressed for winter. Of all the seasons of the year, Glenwood brook is prettiest times like this—altho 'tis fair to view on the days of other months.

How the brook rejoices to be doing its work again! How good it is for the stones to be refreshed and worn smooth!

Does not the Chickadee or Nuthatch abide in the hollow trunk by the cascade, which last year was used by the Woodpeckers? Surely the birds love such woodland spots better than we.

I was born and reared on the banks of Glenwood brook.

Even now I am discovering its great beauty as hundreds of young hemlocks are becoming trees along its banks.

Its music is getting into my veins. Altho I should some day be far away, yet the story the brook tells will never be forgotten.

Things of Nature, even though they have no tongues to speak, as we, do inspire and influence our lives and our endeavors. Happy brook, sing on! Dance on your way to Champlain Lake and the great St. Lawrence and on to the mighty sea.

# THE NATURE-STUDY REVIEW

DEVOTED PRIMARILY TO ALL SCIENTIFIC STUDIES OF NATURE IN  
ELEMENTARY SCHOOLS

Published monthly, except June, July and August. Subscription price, including membership in the American Nature Study Society, \$1.00 per year (nine issues). Canadian postage, 10 cents extra; foreign postage, 25 cents extra.

**Important** Please note date of expiration of your subscription on the label of the wrapper. Subscriptions must be paid in advance to comply with postal requirements. Subscriptions and advertisements should be sent to *The Comstock Publishing Co., Ithaca, N. Y.* Manuscripts for Publication and Books to be Revised should be sent to the Editor.

---

## Editorial

### EXPERIMENTAL SCIENCE AS NATURE-STUDY

Granted that Animate Nature appeals more strongly and more frequently to the child than the Inanimate does, it does not follow that the latter should be excluded from the course in Nature-Study. If choice of matter is to depend on the child's interest it does follow that the preponderance of the biological matter will gradually become less marked as the child's experience widens and becomes more reactive towards environment. The merely observational attitude becomes more and more experimental as the child's education progresses.

There is evidence that many teachers are yet confusing nature study with formal science. They seem to think in effect that the former consists almost wholly of ornithology, entomology and botany modified for the nursery and that the chief modification consists in the exclusion of the language of precision—"technical terms." "In a course of lessons on insect life one might begin with etc" is what the teacher of formal science might say. There is no "course of lessons on insects" for the nature-study teacher. An important difference between the two kinds of lessons is that one is chosen from or originates in a syllabus or text-book; the other from real experience. Nature-Study is education thru the investigation of experience. Using the term "experience" to include observation the longer I try to work out the nature-study idea, the more satisfactorily does this brief statement define it. Making lessons at school of things the children see and do at home and outdoors is genuine nature-study. When parents and teachers cooperate to direct and enrich the children's experiences with



intentionally educative aims the easier it will become to employ twenty or thirty minutes daily in the school-room upon the educative consideration of such experience.

This principle shows the way in which the experimental sciences may serve nature-study and reciprocally the nature-study method may react favorably upon the formal science teaching. Ex-president Eliot has said that in spite of his former very contrary opinion he had come to regard much of the experimental work in physics and chemistry as little better for scientific education than studying columns of a dictionary would be for English composition.

Phenomena and activities treated of in text-books of physics and chemistry come within the experience of children. They are often very interesting and so far as the causes and effects involved can be understood by them, they ought to be given a place in the nature-study work. So the need or the opportunity for such lessons rises in the pupils' experience either according to or regardless of the teacher's plan. The pupils with a clear idea of the phenomenon or problem in mind should have a share in the devisement of appliances for its elucidation and be guided in discovering, if possible, the truths demonstrated in the success or failure as the case may be of each step in the experience.

For example—it is desired to remove the sediment from a fish-globe or aquarium without disturbing the algæ on or near the surface. The teacher will interest the pupils in the problem and set them thinking to invent means of working it out. Drawing the sedimentary layer off with a rubber tubing may be proposed and thus the siphon is introduced. In the making and using of this apparatus, proposals are accepted, discussed and tried. Measures that the teacher may know will be unsuccessful are, unless disproved by the children's own deductions, tried out as faithfully as those that the teacher expects will succeed; for educational purposes such failures may be the greatest successes.

When interest in the action of the siphon as a machine is aroused desire will be excited to know, why the water runs uphill, why it runs faster as the delivery end is lowered, why it ceases to run at the point when it is level with the water in the vessel, why the heavier sediment moves to the entrance of the siphon and rises in it, etc. Each of these observations and experiences becomes in turn a "need" for a new lesson or an extension of some phase of the old one.

JOHN DEARNESS.

## The Teacher's Corner

I do not believe that any teacher knows what a good time with her class really is until she has studied a brook with them. This work should come when the pupils are beginning their physical geography,—although there are parts of it that may be used in earlier grades. “But” the teacher objects,—“How am I to take a class out and not have a picnic instead of a study of the brook?” There is one satisfactory answer to that. Plan the work definitely. Put the questions given in the outline for studying the brook on the black-board and have each pupil copy them in his note book and demand results. You will not need to demand them for the children will become so interested that they will stimulate each other. If you can not study a brook for its full length go out for a Saturday with what pupils you can and study a section of a brook. A fifth grade boy once sent me a set of blue prints illustrating every phase of his brook.

Before going out it would be well to use the following story as a reading lesson.

### HOW A STREAM WORKS AND THE TOOLS IT USES TO WORK WITH

It is perfectly natural for water to be busy. There are so many things about it which it is obliged to busy itself,—such as making clouds and fogs and helping plants to grow. However, it is as a digger that we study it when it is doing the work of a brook.

When water is at the top of a mountain, or on any land higher than the sea, it is not only in a hurry to get down to the sea level, but it always insists on taking along as much land as it can carry. Water is always working to level the surface of the earth; it not only tears down mountains, but it builds up valleys. If we should follow almost any great river to its source we should find that away up in the hills, somewhere, it began life as a little brook. And it is as a brook then, that it commences to work. So, if we go out and observe any brook and see how it works, we shall know how a creek or a great river works.

First of all, the water of a stream is a most successful ditch digger; but instead of throwing out the earth as it digs, as does man when he digs a ditch, the water carries it all off down stream. From our standpoint there are many strange things about the way water carries off dirt and gravel.

When we have a load to carry we go very slowly; we have to. When we wish to run swiftly we throw away all that we are carrying, so as not to be weighted down. When college boys or high school boys run races they do not even wear their ordinary clothing, but dress as lightly as possible, in trunks and tights. They also train themselves severely so that they do not have to carry any more flesh on their bones than is necessary. Now, with a brook exactly the opposite is true. The faster it runs, the more it can carry, and the heavier it gets, the faster it runs.

We have noticed a brook just after a hard rain. We saw it hustling along as fast as it could go; and we saw it was roily and muddy; we also saw that it was much deeper and wider than usual. All this meant that the brook was working very hard that morning.

Now, everyone knows that every brook or creek or river is made up of many drops of water that are, for the time being, united together and doing the same thing, which is usually simply flowing down hill. What had happened to this special brook that morning was that during the rain many more drops had been added to it, and it became excited and began to flow more swiftly, and every drop that could reach the bank or bottom snatched up a tiny load of earth and began to carry it along. But every drop thus laden down very soon struck so hard that it loosened another piece of earth, which another drop snatched up and carried on down stream. After a time there were so many drops carrying loads and bumping along, knocking loose more earth, that the whole brook looked muddy. Every drop in that brook that touched the bottom or bank used its own little piece of earth or gravel as a crow-bar or pick-axe with which to pry up other bits of dirt and gravel for the on-coming drops to carry. The drops all hastened on, working hard together to dig the channel of the brook wider and deeper. Sometimes in steep places the drops would get so wild with haste that several together would pick up a pebble or a stone and with this they would batter down large pieces of the bank or scrape out great holes in the bottom of the stream.

On and on the brook flows—a gang of workmen, each using his load as a tool, moving in close procession and working double quick. But as soon as the brook reaches a plain or level, the drops begin to feel tired and suddenly conclude that they have worked hard enough for that time; more than that each one feels inclined to drop his own load at once. The drops carrying the larger pieces of gravel and rocks get tired first and throw their burdens down, while the drops carrying the fine dirt and mud are not so tired and carry their loads farther; but finally they, too, throw them down. If we look where there has been a flooded brook, we shall find that the gravel is dropped first always, and the fine mud carried farther on before it is deposited.

So, now, when we see a brook or stream all roiled and muddy and noisy, we shall know that it is working very hard, and with its thousands of tiny pick-axes is making its channel wider and deeper. But when we find a brook just babbling along—the less it has to do, the more it babbles, the water so clear that every pebble on the bottom is visible, we shall know it is in a very lazy mood, and is not doing any work to speak of that day, but is just loitering along, catching sunbeams and playing with the fish.

#### THEMES FOR ENGLISH EXERCISES

##### *Where the Waters of the Brook Go*

The story of a little boat that was set afloat on the brook and continued floating until it reached the sea. On what streams would it sail? Through what townships, counties, states and countries would it pass? What cities would it sail by?

##### *How a Stream Works and Plays*

When does a stream work and when does it play? Tell how the waters look when at work, and how the work is done. How and when and why does a brook give up its load?

*The Submarines in Our Brook*

This should be an account of the fish, crayfish, and insect larvae, which live below the surface of the water.

## EXPERIMENT IN SEDIMENTATION

Take a glass fruit jar nearly full of water from the brook, add gravel and small stones from the bed of the brook, sand from its borders and mud from its quiet pools. Have it brought into the schoolroom, and shake it thoroughly. Then place in a window and ask the pupils to observe the following things:

(a) Does the mud begin to settle while the water is in motion; that is, while it is being shaken?

(b) As soon as it is quiet, does the settling process begin?

(c) Which settles first—the pebbles, the sand or the mud? Which settles on top—that is, which settles last?

(d) Notice that as long as the water is in the least roily, it means that the soil in it has not all settled; if the water is disturbed even a little it becomes roily again, which means that as soon as the water is in motion it takes up its load.

## A GAME TO PLAY WHILE STUDYING THE BROOK

The following game used as a part of the Rhode Island Arbor Day program is so full of excellent suggestions for pupils studying a brook that we publish them as a part of this work. The first six questions can be changed to fit the locality under observation.

## QUESTIONS FOR FIELD OBSERVATIONS

Inter-class Meet, Lincoln Woods, Arbor Day, May 11, 1917

Designed for those not assigned to special games, who should organize by classes. The number of points made will depend to some extent upon the organization. Each question answered correctly means the credit of one point toward a final score. One delegate from each class should be prepared to report the data agreed upon to the following committee: Dr. Carroll, Mr. Brown, Mr. Vinal.

1. Which is higher above sea-level, Olney Pond or the next pond in an easterly direction?
2. Where is North? (Show by sun.)
3. How far is it by the shortest route from Twin Rock to the Butterfly Factory?
4. Point to Providence, Pawtucket and Woonsocket.
5. Is Olney Pond at its highest level? What is basis for answer?
6. Account for the difference in soil on the bottom of Olney Pond and on the bottom of the outlet?
7. Name one floating plant that you may observe in Olney Pond.
8. Obtain one wading plant.
9. Obtain one submerged plant.
10. Catch a dragonfly nymph.
11. Find the larva of the caddis-fly in its case.

12. Catch a whirligig beetle.
13. Find a pond snail.
14. Locate the home of a muskrat.
15. Get a fresh water mussel shell.
16. Obtain a water plant that has enlarged air spaces. Mechanical tissues are not needed to support the water plant.
17. Some water plants have a mucilage to help them float and as a defense against animals. Find one.
18. One group of aquatic plants develop bladders. Find one.
19. Is Olney Pond natural or artificial? Basis for answer.
20. What part of Olney Pond is deepest? Reason for answer.
31. Find a rock that the glacier left.
22. Find a rock not left by the glacier.
23. What town are you in?
24. Find a wind blown tree.
25. In what direction do the uppermost tips of the evergreens bend? Why?
26. In what direction is the wind blowing?
27. What is the weather going to be to-morrow?
28. Find little maple trees or oak trees just sprouted.
29. Find a bush in the damp woods that has a yellow blossom. The leaves have not come out and the broken twigs have an aromatic odor.
30. Locate a squirrel's nest. What is the material?
31. Find a specimen of equisetum (Horsetail).
32. Locate a woodchuck's hole. Is he at home? How know?
33. Gather some frog's eggs.
34. Locate a crow's nest? Of what is it made?
35. Obtain the fruit of the elm tree.
36. Find the end twigs of oak trees which gray squirrels have scattered over the ground.
37. Find a pine cone from which the squirrels have removed the seeds.
38. Find some land snails.
39. Find a tree that the woodpecker has "pecked" for grubs.
40. Find limax, the garden slug.

---

### FORTHCOMING ISSUES

The winter birds will have complete possession of the December Number. A full account will be given of the benefit these birds work in our orchards, forests and fields. An outline will be given for school room as well as out-of-door work, and what to feed birds and how and where to attract them.

The January Number will be devoted to the winter habits of our common wild animals and will contain a delightful, illustrated article on the study of tracks in the snow by Professor Hegner of Ann Arbor and a detailed description of a study of animal tracks made by the pupils of a rural school.

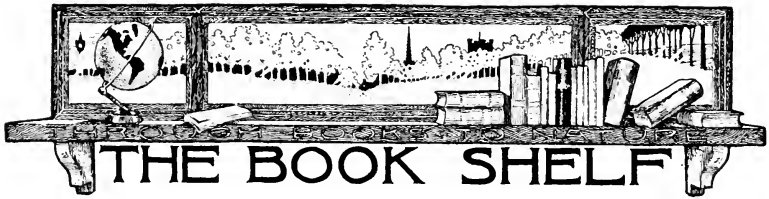

*Louis Agassiz as a Teacher.* Lane Cooper, Professor of English Language and Literature in Cornell University. 74 pages with portrait frontispiece. Comstock Publishing Company. \$1.00.

Professor Cooper has given to the thoughtful teacher a volume of the utmost importance. Agassiz was our first great nature teacher and established for us true nature study methods by taking his classes out of doors to study living creatures in their environment. Professor Cooper has gathered from the writings of Agassiz's four famous pupils, Shaler, Verrill, Wilder, and Scudder, their testimony as to his methods and personality as a teacher and the result is truly enlightening to the teacher of any subject whatever. "The study of nature is an intercourse with the highest mind"—declared Agassiz and his teaching showed that he never forgot to give reverence to this mind.

*Pets, Their History and Care.* Lee S. Crandall, Assistant Curator of Birds, New York Zoological Park. 372 pp. with many illustrations from photographs. Henry Holt & Co. \$2.00.

This book is almost a zoology, so extensive is the number of species discussed. Mr. Crandall from his point of vantage in the Bronx Zoo has been able to form a wide acquaintance in the animal and bird world. His accounts of each are clear, interesting and succinct. The rules for their care are based on general principles and are not obscured by many details which so characterize so many of the English books on pets. The illustrations are truly illustrative and very attractive and interesting, all being photographs of the creatures. It is a very valuable book of reference for nature study teachers.

*Muck Crops.* By A. F. Wilkinson. Pp. xiii + 257, illustrated. Orange Judd Co., 1916.

This little hand-book for the grower of vegetable crops on reclaimed muck land, contains an introductory account of muck formation in swamps and bogs, chapters on the value of muck as a soil maker and fertilizer, chapters on drainage and tillage, and separate chapters on each of fourteen of the most important crops that are grown on muck—celery, lettuce, onions, mint, etc. It is a very readable little book, and very convincing of progress in the application of science to the utilization of the waste wet lands. J. G. N.

*A Year of Costa Rican Natural History.* By A. N. and P. P. Calvert. Pp. xix + 577 with colored frontispiece, map, and many illustrations.

This is such a manual as any naturalist or traveller might wish to have at hand when sojourning in the tropics. It treats of Costa Rica, a beautiful

and healthful and hospitable country that is destined to be better known to Americans in the future. The book contains much information concerning topography and transportation, gives many interesting glimpses of the life and ways of the people, but it is mainly an account of the plant and animal life of the country. We know no book of travel that is so carefully written, or so full of detailed information as to the haunts, habits and recognition marks of the commoner species. One might go collecting in Costa Rica and identify most of his captures by means of the pleasant reading these pages afford.

The chapters end with a vivid account of the great earthquake of May 4th, 1910, which destroyed the city of Cartago, and in that destruction wrecked the little laboratory in which within a year's time Dr. and Mrs. Calvert had done so much noteworthy and original work upon tropical American dragonflies. An appendix contains a bibliography, lists of the species discussed, and other important data.

J. G. N.

#### TO OUR SUBSCRIBERS

Please note your expiration date and send in your renewals promptly.

Owing to the increased cost of paper and printing, also to the fact that *The Nature-Study Review* has not raised its subscription price, we will print only enough magazines each month to cover the subscription list and its normal increase.

A blue check on the wrapper indicates that your subscription expires with this number.

## Outline for Butterfly Study

*Mrs. Constock's valuable Outline for the Study of Butterflies as used at Cornell University can be purchased.*

This article appeared in the September issue of the NATURE-STUDY REVIEW. The demand for it make a reprint necessary.

Price, single copy 25c postpaid. 10 copies or more 18c each, postpaid

ORDER NOW FROM  
THE NATURE-STUDY REVIEW  
ITHACA, NEW YORK

## AQUATIC LIFE

*Per Year \$1.00  
Single Copy 10c*

The only magazine in America devoted to the care and breeding of native, foreign, gold and fancy fishes, aquatic plants, molluscs, and other animals in the home aquarium. An illustrated monthly journal edited by W. A. POYSER.

JOSEPH E. BAUSMAN, *Publisher*  
542 EAST GIRARD AVENUE  
Philadelphia, Pa.

## The Guide to Nature

Edited by EDWARD F. BIGELOW

A Monthly Magazine from the Naturalist's Point of View.  
An interchange of observations by students and lovers of nature.  
*NATURE is good in the school, because it is good anywhere for all people.*

Subscription \$1 a year.  
Four months' trial 25c.  
Single copy 10c.

THE AGASSIZ ASSOCIATION

ARCADIA

SOUND BEACH

CONNECTICUT

Kindly mention THE NATURE-STUDY REVIEW when replying to advertisements



# THE NATURE-STUDY REVIEW

---

VOL. 13

DECEMBER, 1917

No. 9

---

## Three Chickadee Friends

ANNIE LINN

Detroit, Michigan

They came to us late in November, when no living thing was left in the wind-swept garden, save glistening green honeysuckle leaves, and a few chilled chrysanthemum buds, struggling valiantly to open their frost-nipped petals. There were three of them; three gray-clad sprites with glossy black caps on their sleek little heads. Their coloring was as somber as the November twilight, but they seemed to fill the sleeping garden with their exuberant life. They flitted through leafless shrubs, and hung head downward from the grape-vine on the fence; they swung from honeysuckle sprays and played amid the smoky gray mist of the winged clematis seeds ready for flight, making sweet, low sounds as they talked to one another. They feasted on sun-flower seeds and cracked nuts, perched high on our improvised feeding table.

The table was a crude affair, made of rough pine boards placed across the top of a garden hammock-frame; but it was safely out of reach of alley cats, and large enough to give ample space for a shallow drinking pan, and for several lumps of suet tied securely to small branches of apple wood; and bird-guests are not critical.

The Chickadees shared their table with a few White-breasted Nuthatches and downy Woodpeckers. Our English Sparrow friends, being conservative by nature, viewed with distrust an unfamiliar object in a garden which they regarded as their own, and refused to come to the new feeding table. We promptly took advantage of their prejudice, and gave them their oats in a place of our own choosing; an arrangement to the advantage of all.

We soon learned Chickadees' preferences in food and their regular meal hours. They breakfasted early in the cold gray

dawn of the winter mornings; they dined at eleven, and came to supper between four and five during the short days of winter. They had good appetites, and needed frequent lunches between meals. They enjoyed nuts of all kinds, from pecans to peanuts; but they preferred butternuts and walnuts and took them first, if they were offered a choice. Sunflower seeds were always acceptable, and hemp seeds were in high favor, especially, after we discovered that the Chickadees had difficulty in opening them and we crushed the hard shells for them.

Before we were fully convinced that our birds could not open hemp seeds for themselves, we often saw them hold an unopened seed in their bills, as if unable to eat it but loath to let it go. In order to be quite sure, we filled a small wooden bowl which we kept for broken nuts, with hemp seeds, both crushed and whole, and put it on the porch table where the chickadees usually came for breakfast. In a short time a sharp, rapid, pattering sound was heard on the tin covered floor. When we went out to investigate, a chickadee stood in the middle of the bowl, scattering the unopened seeds in every direction, and eating the crushed ones with evident satisfaction.

At first we were content to watch the birds from a distance; we could scarcely expect them to come to a sunny shelf on the dining room window sill which we had prepared for possible bird guests; still, we had read thrilling tales of the confidence of Chickadees in their human friends, and it was not impossible that we too might be honored by their friendship. So we made the window shelf as attractive as possible, and waited hopefully.

The Nuthatches, discovered it first. Then, one December day, with a flutter of gray wings, and a patter of little feet, the Chickadees came, and settled down on the window-ledge where they ate their nuts and seeds serenely, quite undisturbed by eager, watchful eyes at the window. Even when no one was looking for them, their presence was announced to listening ears by contented twitterings, and an occasional cheery "chickadee-dee-dee", and by the peck of strong bills as they opened their sunflower seeds with swift strokes, while they held them firmly with their claws.

One day, an excited observer announced to her incredulous family, that one of the Chickadees sat down on the table, and held his piece of walnut shell in both feet, while he ate his nut.

None of our books nor of our more experienced bird-loving friends had spoken of such an amazing feat. Could it have been a mistake? They who had not seen it, were inclined to believe that it was. As we waited at the window, back came a Chickadee, turned his tail at a sharp angle, pressed his breast against the board and grasped his walnut with both feet; he has even been known to turn and to lie on his side while picking out crumbs of nut from the shell. Once he stood on one foot and steadied himself by clinging with a cold little claw to the finger of a friend, who was trying to help him hold his nut.

All day they came and went, and soon became so tame, that we could open the windows without disturbing them. They ate from our hands without haste, or fear, and once, when a hand was placed too high to be reached conveniently while the bird stood on the table he spread his wings, flew up a few inches, and dropping down as gently as the snow flakes which surrounded him he stood with cold little feet on the waiting hand.

In the early days of our acquaintance we spoke of them as the Chickadees, but as we became more intimate with the personality of each, they seemed to us as unlike in character and appearance as three children, and names became a necessity: so we called them Jimmy, Sammy, and Fluffy.

Jimmy was an energetic, athletic, chickadee person, with surprising strength of bill and claw. When especially vigorous strokes were heard through closed windows, we knew that it was he who was opening his sunflower seeds. He was handsome, slender, and extremely neat. He never appeared in public with a single feather displaced. His bearing was confident and fearless at all times. His disposition, however, was less pleasing than his appearance, and we regretfully admitted that he was not generous in his treatment of his two companions: still with all his obvious faults, he was most lovable and winsome.

Sammy was interesting rather than handsome. He was slightly larger than Jimmy, less self-assertive, and far more indifferent about his appearance. Perhaps his coat was more difficult to keep in good condition. He never looked well groomed, and one of his long tail feathers was broken at the end: we hoped that Jimmy was not in any way responsible for this mishap. Sammy was reserved, and silent, seeming to expect little companionship from the other chickadees. In repose, he looked

dejected, and he opened his sunflower seeds with less vigor. With all his pluck and independence, there was something about Sammy which made a strong appeal to our sympathies, and we lost no opportunity to comfort him with butternuts, in his moments of dejection, when Jimmy was too much occupied with his own affairs to interfere. We never knew Sammy well. Jimmy's relentless hardness of heart and persistent discourtesy toward him, combined with his own natural reserve, made intimacy impossible.

Fluffy, the beloved of our flock, was as sweet a little gray lady as ever won the hearts of a large circle of devoted friends. She was plump and round and daintily pretty. Her feathers seemed finer and thinner, and her wings smaller than those of the other chickadees. At times, a downy film of breast feathers almost concealed her wings, making her look more like a fledgling than an adult bird.

She accepted our hospitality with gentle appreciation. She soon became established as a member of our family circle, and seldom left the balcony and her favorite window-shelf for more than a short flight out into the wintry world.

She often sat for a long time on a spray of woodbine in the sunshine, preening her feathers, and twittering softly to herself. We never knew the variety and sweetness of chickadee language, until we had lived close to Fluffy day after day. She ate her nuts contentedly on the window-ledge, selected her seeds with deliberation, and drank from her pan while we sat at the window with books or work. She watched us with bright, friendly eyes when we opened the window to offer some tempting morsel of food, or to fill her drinking-pan with fresh water; even when it was necessary to break or to remove the ice, as it often was, before refilling her pan, Fluffy did not fly away. Sometimes she would peck the ice a few times, and look up at us with wise, trustful eyes while she waited for assistance.

She slept under the projecting cornice of the balcony, on a narrow ledge, close to the screen. When she was settled for the night, all that could be seen of her, was the tip of her tail, which hung down against the netting. We always looked for that reassuring proof of her presence in the wintry dusk.

One night, the precious gray atom was not in its accustomed place. A diligent but cautious search with shaded candle and

flashlight failed to reveal it. Fluffy had not seemed quite well for several days, and our hearts were sore for her, out in the cold alone and weak. Should we find a lifeless little body in the snow, when we looked for her in the early morning? We went to bed with heavy hearts that night.

Fluffy came as usual for breakfast, but she was unmistakably ill. She sat on the window shelf in the sunshine, with soft feathers puffed out and her bill open. She did not even notice that her tail feathers lay in the icy water of her drinking pan.

An anxious friend opened the window, and with caressing fingers changed her position while Fluffy offered no remonstrance. We afterwards learned from more experienced friends, that birds do suffer much from the cold in severe weather. Perhaps that was the cause of Fluffy's indisposition, but we were never sure. Sorrowfully, we watched the little invalid, and many a consultation was held as to the best way of caring for her. We gave her diet careful consideration, and tried to tempt her failing appetite with crushed hemp seeds in addition to her favorite nuts and sunflower seeds. We kept a supply of canary gravel on her table, and changed her drinking water frequently.

It occurred to us during Fluffy's illness, that if we could make the balcony sufficiently attractive, she might be persuaded to take up her abode inside, where she would have more protection from wind and snow. A young nephew fastened a branch in the roof, and two pieces of wire netting were removed from opposite sides of the screen. Fluffy soon found the place which had been prepared for her, and every night she slept in her chosen niche. Like the trusting little lady that she was, she selected her sleeping place close to a door which was seldom closed at night. The first sound that we heard in the morning was her contented, sleepy little twitter before she came down to eat her breakfast with Jimmy and Sammy, on the porch table.

For many weeks there were few late afternoons that one or more of her devoted family did not watch her make her bed time preparations. "Come between four and five," we often said to interested friends who wished to see Fluffy eat her supper, take several sips of water, and go upstairs to bed fluttering softly and turning her little head from side to side, to look down at us confidently as she settled herself comfortably for the night, like a sleepy baby in its crib.

An early riser in the family said that Fluffy's manner of coming down from her branch in the morning, always suggested to her the familiar picture of beautiful Queen Louise descending her palace stairs.

Fluffy's determination to continue her baths when the weather was too cold for open air bathing, and her strength seemed insufficient for the ordeal, caused us much anxiety.

Early one bitterly cold morning, when the bird's drinking pan had been refilled with slightly warmed water to prevent its immediate freezing, she took such a thorough bath, that she looked half drowned to the horrified friends who found her clinging to a vine, dripping wet, seemingly exhausted, and in momentary danger of freezing to death. In despair we stood at the window, wondering how we could rescue her. At that critical moment came Jimmy, equally wet from his bath, and with characteristic energy and determination he compelled Fluffy to join him in a game of "tag" until both birds were thoroughly dry.

Our Chickadees were not forgotten at Christmas time. Two bird-loving friends prepared one of their little balsam trees which they had brought home with them from a summer vacation in the Adirondacks, for our pets. It was loaded with every imaginable dainty, dear to the heart of a chickadee. When the little tree was carefully unpacked, and placed on the feeding table, close to the dining room window, we all watched breathlessly to see how it would be received.

In a few moments Jimmy arrived. He began at the little platform at the base of the tree, and concluded his approving inspection on the topmost branch. With scarcely more than the window between their table and ours, we ate our Christmas dinner together. The Christmas tree became a favorite resort of the Chickadees, and they used it regularly until the last needles fell in the spring sunshine.

There were days, during the winter, when Sammy and Jimmy were only occasional visitors at the feeding table, but Fluffy stayed contentedly at home. When Jimmy was with us, he seemed to think that all bird comforts and conveniences belonged to him. Fluffy meekly acquiesced, and Sammy accepted the trying situation with stoical resignation.

Only once, when Jimmy had been away for some time, and had returned unexpectedly, did Fluffy refuse to withdraw at his

bidding, and raising her voice in protest, she drove him from the window. We hoped that a new order was established, and that Jimmy at last, would receive some much needed discipline; but Fluffy was too gentle to be aggressive in her own behalf. Perhaps her tender heart relented toward the lovable tyrant. However that may be, when the great snow storm came, and Jimmy for the first time sought shelter inside of Fluffy's balcony, she promptly yielded her favorite place close to the door, to him, and when he wished to eat his seeds on her table, she took her food from the floor.

Jimmy even drove her out into the storm by his restlessness and aggressiveness.

That was too much to be endured by us and he was indignantly "shooed" away. He soon returned and could not, or would not understand that we regarded him as an offender.

A little nephew, who was distressed by Jimmy's conduct, suggested that we say "tseep tseep" sharply to Jimmy, as he did to Sammy and Fluffy, thinking that he might understand our remonstrance better in his own language than in ours. Fortunately for Fluffy and for us, Jimmy felt no desire to remain in the balcony, and before night, when the worst of the storm was over, he flew away, leaving Fluffy free to live her contented, uneventful life with us.

She stayed in her sleeping place late in the morning after the storm. There was really nothing else for her to do. She could find no place for her feet in the snow-laden vines, and all her familiar resting spots were heaped high with snow. Her breakfast was, as usual in stormy weather, on her inside table, but she showed no inclination to descend into the strange, white world. We took out her bowl, filled with crushed hemp seeds, and spoke comforting words to the little gray fluff ball in the branches over our heads. She answered immediately in her own sweet way and hopped eagerly toward us. In a few moments she was on the table enjoying her late breakfast: but she made no effort to go outside of the porch that day.

As the days lengthened, Fluffy and her companions ate their supper late in the afternoon, and seemed to enjoy a regular bedtime frolic. A few times Fluffy went to bed early as usual and changing her mind, came down and went out to play.

Toward spring, Jimmy established himself on the front porch,

and took his seeds and nuts from a fig-basket, fastened to a post close to the window.

In wet and stormy weather, he often took shelter between the window frame and an applewood log, placed for his convenience on the window ledge.

Early one morning he came into a bedroom, through the open window as he frequently did for his early breakfast of broken nuts on the inside sill. In some way, he became confused in going out and losing his way and becoming frightened, he fluttered helplessly against the glass. Fortunately, a friend heard him, and went immediately to his rescue. With reassuring words she helped him to find his way out, and in a short time, Jimmy was visiting with Fluffy at the back porch, none the worse for his fright. We fancied that he seemed somewhat subdued in spirit, and even a little more considerate of Fluffy, but the apparent reform did not last long.

After Jimmy's adventure, which might have resulted seriously for him, we began to doubt the wisdom of encouraging the chickadees' friendly way of hopping in at open windows wherever and whenever they might find them.

The chickadee habit of storing food for future use was most interesting. They carried sunflower seeds from place to place, searching for crannies in the wall, or for any snug niche in which to hide them.

One day, Fluffy, who had finished her meal, came quickly across the window shelf, holding a seed in her bill, and looking eagerly about her. She stood near a small branch of applewood to which her lump of suet was tied. After the consideration due to such an important matter, she tucked her seed carefully into a split end of the stick, and contemplated it with satisfaction. It did seem a safe place, known only to herself and to the friend she had taken into her confidence; but scarcely had she gone, when Jimmy dropped down from one of his many strongholds in the vines, and pouncing upon Fluffy's seed, he bore it off in triumph.

Of course, there were plenty of sunflower seeds quite as plump and oily as that one which Fluffy chose, but Jimmy's conduct was difficult to overlook.

Of all the delightful chickadee customs with which we became familiar, none was more interesting than their way of dropping down suddenly from fence or branch into the newly fallen snow.



To walk up and down a narrow path in a city backyard, with snow heaped high on either side does not seem exhilarating, but, to be accompanied in one's walk by a little gray friend with wings, who "prints his small impress in the snow" from the pure joy of living on a February day,—that is a different matter.

One day, not a chickadee could be seen nor heard in the garden. They did not even come to the window shelf at their regular dinner hour. It was an anxious time for the entire family. With heavy hearts we thought of alley cats and unknown dangers. When the suspense had become painful, the telephone bell rang and a joyful voice announced: "we have three chickadees on our feeding table in the garden; they have been here all morning."

Comforting as this message was, it was not wholly reassuring. Would the chickadees desert us for new friends? Fluffy came home before bedtime, her sweet trusting self, and Jimmy and Sammy arrived in due season.

Our chickadees received many calls from bird lovers, who had heard of them through family friends.

A baby girl, who delighted in coming "to see Fluffy," stood silently at the window one cold day, and after watching her with grave, tender eyes, she asked her aunt anxiously if she might not send Fluffy a blanket from her crib.

Once, while Fluffy was still delicate, as she was sitting on the edge of her table, resting, and warming herself in the sunshine, a friend called to see her.

He seated himself quite closely to the window, and waited for her to become accustomed to his presence. She had finished her breakfast, and was not yet ready for a lunch. In our eagerness, to have her show him some of her confiding ways, we tried to persuade her to take nuts from our fingers. She hopped away a few inches, to one of her favorite resting places in a vine, close to the wall, and looked at us with friendly, fearless eyes, but refused to come on our hands or to take food.

One of her most intimate friends leaned from the window, and reaching out her hand until her finger-tips rested in the soft gray down of Fluffy's breast, said to her entreatingly: Fluffy, do take a nut; just one little piece. Slowly, she turned her head and leaning forward she took a crumb of walnut daintily, as if to give us pleasure, rather than because she wished for it.

As spring approached, Sammy left us. We had noticed regret-

fully that his visits to the various feeding places were less regular and frequent than usual, and before many days they ceased entirely. Sammy had seemed well, and in good spirits, but from the beginning of our acquaintance there had been strained relations between him and Jimmy. As Jimmy became less inconsiderate of Fluffy, his coldness toward poor Sammy increased perceptibly. Without having positive proof that it was the case, we could not help feeling that Jimmy's unkindness had much to do with Sammy's departure.

After Sammy went away, Jimmy spent more time with Fluffy in the grape vines on the back porch. Their growing intimacy caused us much anxiety. Handsome and lovable as Jimmy was, we never felt much confidence in his goodness of heart. That he seemed to be improving, we gladly admitted, but, would our precious Fluffy's happiness be safe in his keeping?

We had heard of chickadees consenting to live in properly constructed nesting boxes. Would it be possible, we wondered, to keep Fluffy so close to us that we could feed and protect her when she was caring for her nestlings?

A young nephew, one of Fluffy's most devoted friends, made a comfortable little house after an approved model. We did not offer her a ready made bird house because as Carl remarked: "her home ought to be made especially for her by one of her own friends." After careful consideration we decided upon the particular spot on the porch column where the interlaced stems of woodbine, grapevine, and clematis afforded protection without interfering with the spring sunshine, and would also provide leafy coolness and shelter from wind and rain as the season advanced. While Carl was putting up her house, Fluffy, undisturbed by the sound of his hammer, swayed on a vine spray, close to his shoulder. As the last nail was put in place, her sweet low twitter rippled into a clear ringing "chickadee-dee-dee," as if she approved of his work and wished to express her appreciation of his efforts in her behalf.

Surely, we thought, after such an auspicious beginning she would stay with us.

She often stood on the top of her house, but we never saw her go into it.

Day after day we watched hopefully, and as Jimmy's attentions became more insistent, we were forced to admit that Fluffy was not wholly indifferent to him.

We could not blame Fluffy. Had we not weakened many a time in our efforts to maintain an attitude of severity and disapproval toward him? Jimmy certainly had an irresistible way of his own of disarming adverse criticism, however, just it might be. If Fluffy had only chosen the more dependable Sammy for her mate it might perhaps, have been easier for us to let her go; but Fluffy decided for herself, and we acquiesced not without misgivings.

The balcony was a desolate place the first night that her branch was empty.

She came home to breakfast two mornings and we began to hope that she would not go far away. On the third day, when one of the family enquired anxiously of the earlier riser: "Did she come this morning?" "I hoped you would not ask me," was the sorrowful reply.

Somewhere, perhaps, in a wayside thicket, or shadowy wood, a little gray mother is feeding her hungry brood. Does she dream, sometimes, of her winter home and friends, as she sits on her nest in a hollow tree, guarding her treasure?

Perhaps she tells bedtime stories to her sleepy fluffballs of the unfailing supply of crushed hemp seeds, and of cracked nuts carefully picked out and broken for her. It is not unlikely, that in the joys and cares of family life she has quite forgotten us.

Fluffy's branch is still in the porch roof. Her little house, half hidden by woodbine leaves, has lost its appearance of newness, and is mellowing in the sunshine and rain to a weather-stained gray of which she would surely approve.

Will she come back to us, who are watching eagerly for her? Shall we hear her merry, brave "chickadee-dee-dee" in the garden some cold December day, or better still, the patter of her little feet on the window sill, and the indescribable sweetness of her more intimate and confiding low notes, when we open the window to greet her?

Perhaps, remembering the shelter and abundance of her porch, she will bring her children home some gray November afternoon, and put them to bed in the twilight on her own favorite branch, high up in the rafters.

Even if she does not return to us, she has made us rich with happy memories, and it will ever be the privilege of those who knew and loved her to look upon every little winged creature with sympathizing hearts and eyes which see more deeply for her sake.

## The Memories in Weeds

L. H. BAILEY



T was in a Taoist Temple far away in Honan. Strange were the rites of the priests before the idols. Every utensil, every rude piece of furniture, the food wherewith to find sustenance for the tramps in the torturing heat and wet, the outlines of the clustered buildings, the

speech and the conduct of the few people on this border-land, were all outlandish to an intruder from the occident. The nights came down like a pall of loneliness over the shaven hills, the doors were bolted, and the morning was far away.

Even the plants, the birds, and the insects were strange. But there on the old stone temple-wall grew the catnip, the same catnip that is under my window in America, the same that has greeted me in many wanderings in other lands. What memories it held, and what sweeps of the earth's surface were in its crenate leaves and its odor! Farm-yards and castles, fields at evening, walks where every soul was a stranger, picturesque walls and ruins, lost days of youth with fragrant catnip-tea, folk-lore, an herbarium at home, the years that have crowded each other so fast and so fast,—these were all in the catnip plants that grew in the chinks of the old wall of the temple in China.

Often am I impressed that travelers never see the weeds, and we know that other folks spurn them; and yet they are the messengers sent around the world, the fore-guard of fellowship, the perfect adaptation to all the conditions and needs of life, the tell-tale of old routes of trade. I have learned to love the weeds, so often have they been my companions on solitary journeys. Always do I look for them, as I look for old friends. Rank and raw, uncouth, broken and torn and ragged, often the bearers of heavy odors, asking no quarter, yielding no treasure, the weeds are the commoners on the pathways of life.

Nor was the catnip the only old acquaintance in this place far from the thoroughfares of travel. In the yard was plantain,

wild carrot, the sprawling mallow bearing the "cheeses" of childhood, and the black nightshade. Near by were smartweeds and dock, foxtail grass, and pepper-grass; and in one corner was a lusty plant of fennel, the same fennel that I found growing nearly shoulder high in my garden when I came home. I was not so very far away, with so many good friends to meet me.

Specimens of them I brought home, with others much more rare but not more interesting nor more worth the while. And the first plant of many hundred Chinese things to be mounted in my herbarium is the specimen of catnip from the hills of Honan.



## To the Snow Bunting

WILLIAM PRINDLE ALEXANDER

Welcome, Oh! child of storm and drift!  
 Late guest of Labrador:  
 Most welcome here when through the rift  
 Of frozen boughs, the mad flakes sift;  
 When you, like silver leaves adrift  
 Will come, a happy corps!

Most happy, though the uplands yield  
 But rustling, withered weed,  
 When all the wealth of golden field  
 Within a frosty crust is sealed,  
 And to your peering eye revealed  
 Is naught but bristling seed.

And yet when March winds hoarsely blow  
 The first harsh strains of Spring;  
 To where the North-land torrents flow  
 Through ragged realms of rock and snow,  
 On errant wing again you'll go,  
 Go home, to mate and sing!

Your knowing brethren seek the shade  
 Of orange grove and palm,  
 Where now a sumptuous feast is laid  
 O'er flowering key and everglade,  
 Full fair as that for Pavo made  
 In lands of the Morning Calm.

But you, with little satisfied,  
 And storm enduring breast;  
 The rattling ragweed will provide  
 Your simple need, so here abide  
 And whistle o'er the countryside,  
 My little winter guest!



His turn, next

## Crow Babies

DORA B. HAINES  
Newark, N. J.

Speaking of the crow, Chapman says, "In spite of his great circle of acquaintances, he has few friends. . . . there is a price upon his head; every man's hand is against him." But even a crow may not be as black as he is painted. He is not appreciated by the vast majority of unfeathered bipeds, yet I have met a Vermont farmer who, when his corn is well sprouted, sows the field a second time to attract the crows. "They save the value of what they eat in the grasshoppers they kill," he told me. And whoever has had a tame crow will look with friendly eyes on all others for his sake.

I spent my vacation at a Cape Cod farm-house. During a terrific storm a number of trees were destroyed and in one was a

nest of young crows. The four little fellows were taken to the woodshed and fed on corn meal until they began to fly. Then each had one wing clipped and they were given their liberty. During the day they wandered about the grounds, were fed with the chickens and petted by the family. At night they were "shooed" to a disused hen-house and shut in.

My friend, Miss C. and I soon made friends with the crow babies. As soon as they were released from the hen-house, they would proceed at a flying-walk to the house where we fed them corn and played with them.

They loved the sweet biscuits we had with our tea and four o'clock would find them approaching the piazza with many anticipatory "croaks." If we delayed, they became quite indignant and croaked furiously. Once a crow walked right in at the open door, down the hall, and voiced his displeasure on the threshold of my room.

Another delight of their's was to have their throats scratched or tickled. When we sat under the trees reading or sewing they would gather round us, stretching their necks invitingly and uttering the funniest coaxing "craw-aw-awks." And when we responded how they would push and shoulder one another to get a turn!

One morning the crows all disappeared. We called and called in vain. Not one black feather did we see and not a croak did we hear. We had given them their breakfast as usual and had remarked that their wings needed reclipping. Could they have flown away? We gave up at last and went to the orchard.

Hardly had we seated ourselves when "croak!" came from over our heads. We sprang to our feet. "Croak!" from another tree. "Croak, croak!" Then came a glorious game of hide and seek and Miss C. and I were "it" all the time. The crows kept out of sight in the foliage, but flew from tree to tree as we approached their hiding places, calling "croak" from each new roost. If they were not playing hide and seek, they surely gave a good imitation of it. We were just giving them up when down they all dropped and marched demurely up to be scratched.

One crow was smaller and weaker than the others—like some humans he "enjoyed poor health." He usually stood a little in the background and kept up a series of "craw-awks" in a peevish undertone. He always wanted the bit of biscuit that some one

else had, and would peck scornfully at his own portion, keeping an eye on his brother's and complaining as usual. Coming up from the hen-house he would select the highest part of the stone wall to go over and then stand and scold because he did not succeed. Like many querulous people he could be very obstinate.

A shallow pan with a broad edge was kept filled with water for the crows and they would perch on the edge and drink and bathe at their ease. One morning the peevish crow discovered an old tomato can nearly full of water and proceeded to take his bath in that. The edge was sharp, and from his complaining must have been uncomfortable, but get down? Not he! The opening of the can was so small that when he dipped in a wing it caught on the sides and he had to flutter wildly to release it. We feared he would get hurt and two or three times carried him to the broad pan where the others were enjoying the clear water, but back he went to his dirty old can.

So we gave up trying to help him and took his picture instead. We enjoyed the "croakies" all summer and hoped to see them again the next spring, but after our departure their wing feathers were allowed to grow and they flew away to join their relatives of the field and woods.



He preferred a private bath tub



## What Birds Feed On in Winter

HARRIET REYNOLDS

Upper Falls, Balto Co., Md.

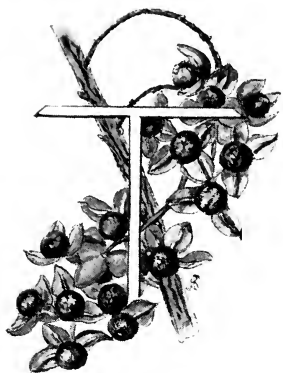

HERE came fluttering about the window, —the temperature was nearly zero, and the north wind blew the hail, and snow about—some tiny white and black birds. The wind rattled the sleet against the glass, and rocked the icy branches, causing the little storm-tossed creatures, when they rested on them, to hold on with all their strength, while their feathers were blown every way. Within were the inexpressible comforts of home, the warm shelter, light, the arm chair,

food, and a delightful resting place for the winter night. Without the homeless, supperless little atoms of life, eagerly watching for the crumbs on the shelf, enduring the cold, braving a storm in which man could not exist, yet surviving bright and happy on the morrow. They were the juncoes, visitors from the North, the snow-birds for they come and go with the snow. If they were whiter, they could have that other pretty bird name, snowflakes, but they belong to another branch of that great sparrow family. Who even heard of a snowbird freezing or minding the cold, they seem to rejoice in it. When they fly away, they show four white feathers in their black tails, this is the only way that they show the white feather of cowardice, for more brave or hardy little birds do not live. Their pretty feet and bills are as pink as the inside of a lovely sea shell, their breasts as white as snow.

Mother Nature made them, perchance of snow feathers, with a tint of black, so that one could see them, and of pink to make them brighter; then sent them away with the flying snow to cheer up dark winter time with life, beauty and attractiveness.

They are the dainty, darling children of the snow, always coming in flocks, gentle and generous to each, sprightly, and merry in their ways. When warm spring airs take the place of cold weather, one thinks how the birds will enjoy the change, but our little, cold weather friends are gone. The southland birds have

come, but those of the northland, having fulfilled their mission have departed for their far-away birth place.

One wonders what they feed upon in winter, for the woods appear a barren waste, yet to the naturalists, as well as the birds, the whole world is one vast storehouse of seeds. When the snow covers the ground, and the weeds what can the birds find? Mother Nature is a better provider than to depend upon the ground and weeds, for there are her other resources the vines, shrubs, and trees.

There is the climbing bitter sweet, whose beautiful berries hang in graceful clusters of golden grapes among pale, green leaves. When the frost comes, the grapes open, turn back into three little cups, and resting upon them are the exquisitely colored, crimson berries waiting for the birds. Even in the Spring, this most beautiful vine of them all, holds her treasures, when the birds do not take them.

The woody nightshade has purple flowers, that are followed by oval, scarlet berries, which hang in lovely, transparent clusters all the winter, and they are dearly loved by the birds. This vine is not a native, as the bitter sweet, and the clematis, but it is the fastest grower, and every bird lover should have one, as well as a shrub, to be mentioned presently. The wild grapes,—fox, chicken, and people's, give them many meals, a wild grape, touched by the frost must taste like wine to a noisy, rowdy jay. Crows and robins eat them with evident enjoyment.

The English ivy, has deep green, varnished leaves and seems to be just suitably finished at the end of the clusters beautiful leaves, by circles of large, blue-black berries. This grand vine, to see one that has climbed 40 feet with its leaves glistening in the sunshine, its berries surrounded by a host of fluttering blue birds, is a sight not to be forgotten. It blooms in summer to have its berries ready for the winter birds. The clematis is not a favorite with birds. I have seen our sparrows eat the brown seeds, but they are covered with silk-like threads, and float away with the wind like fairy umbrellas. The green briar seeds stay on until late in the spring; pheasants like them. Its mission is more decorative, for no vine has such a graceful arrangement of its berries, hundreds of pretty round blue seeds form a centre springing in a rosette, on almost invisible stems. Around a brass lamp or a white picture frame it is a beauty.

The shrubs must begin with another roadside dweller, and it is the queen of them, for the birds love its berries best. The poke, pocoon of the Indians. Pigeon berry was, also, one of its names. Alas! The beautiful wild pigeon, and innocent doves that once migrated in immense flocks have departed, never to return. This handsome plant comes up every year, and can not be called a shrub. It attracts every one's admiration, when the berries are ripe. The wine colored, stately stalk, the red veined leaves, the dark, red berries, all seem to be stained with port wine, the heavily-hanging clusters of berries of rich dark red look like the racemes of currants. How the birds rejoice in these delicious wine berries—even the woodpeckers—insect eaters enjoy them. Mocking birds, robins, every bird comes, so that long before winter comes, they are gone. There is *no tomorrow* in a bird's little life.

There are four other bushes with red berries. Were they made to attract the birds? The black alder, spicewood, and the two burning bushes. The black alder, or winter berry is strikingly beautiful, the most brilliant of all the red berries. There are hundreds of shining, scarlet berries, growing just as close, as possible to the branches, and the color does not change with the frost, as the other berries do, but remain bright until the spring. They are brought to the cities, and it seems a pity that such a lovely bush should be destroyed, as it is a slow grower, and belongs to the birds. The spicewood, whose fragrant wood grows only in Canada, and the United States, seems some form of a tropical plant in our climate. I have seen the allspice in Jamaica, and the berries grow in the same way, that is, the seed inside a red covering, that is soft, and then becomes hard. Its long, crimson berries are prettier, more odd looking, but grow more sparsely along the branches, as the coffee berry grows. The burning bush, —euonymus, or best—is more attractive to birds than any bush, except the poke. Every bird lover should plant some of these pretty little trees, because they are magnets to draw all the little, hungry, creatures. The red birds come from far and near, the blue birds flutter over it in flocks, sparrows and robins come and feast. There is no brighter scene, than this brilliant bush covered with its lovely pink and red berries, with a flock of birds, flying over it, hanging on, chirping their delight at their wayside inn. The berries are three crimson seeds in an outer shell of pink;

they are numberless, and hang on the branches by a pink stem or thread. When the wind blows, they dance about like fairy things, and the changing pink and red may have suggested its fanciful name. The other one, the native of this country is the prettiest, for the outer shell is just like a strawberry, but it is rare.

The hawthorns, or black haws bear blue berries in a close, round cluster, with red stems. The seeds are flat, of sweet taste; most berries are sour, and they have but little substance, yet the birds love them, when they pause for refreshments on their journey south, for they are seldom found in the spring. The exquisite white flowers that come in the spring are unequalled in beauty and fragrance.

The trees have their hotels for the hungry ones, and the wind is the manager for it blows the seed pods about, and spreads a feast on a table cloth of snow. There are more trees than can be mentioned, the locust, cigar tree, paulonia and sugar berry, and many others. The partridge haunts the spruce trees, and hemlocks, in winter, it may be for protection, and to seek the small seeds from the cones. They are fed on this place, when there are snows, and as sure as they are forgotten for an evening, they come up to the house, and feed under the locusts. They will also eat broken acorns. After a deep snow there was a flock of birds very busy under a paulonia. Countless lace work designs of little foot marks, back and forth, showed that they were after the tiny seed, that covered the snow like powder. The sugar-berry or lotus tree is a useful one to the birds. It is a handsome, flat-topped tree, growing in the low lands, the berries are plentiful, as sweet as sugar, and are only a skin over a hard kernel, but the birds enjoy them. The cedar berries are eaten by all, every country child knows the taste of their sweet, blue seeds. Who has not seen, flying around cedar trees, like a flock of fairies, the dainty, exquisite cedar birds, whose grey feathers look like spun silk, whose tail is tipped with yellow, and wings with red like wax. It is said that they are so sweet in their manners, that they will pass a berry from one to another.

The persimmon, the North American date tree—why do people smile at that title? Do they contrast a sweet smelling date with a green persimmon? Just taste one after the frost has touched it and learn how good they are. That is, if the birds have left any.

Many times have I watched a jolly party of crows, those Robin-hood like birds, and observed their clamorous joy at a banquet up a persimmon tree.

The jays love them, also, but a jay likes to come alone, and take fruit as if he was stealing it; that is his idea of enjoying it. It may be, that his bright colors, like those of the red bird, make him restless, as they are better marks for a gun than the other darker birds. The gum is the last one to be noticed, and the best of all, its rich red leaves, and hundreds of blue berries make it most attractive. How all the birds love it, more than any other berry. The robins will come miles and miles to revel in it. The flickers—log cock is another name for our most beautifully marked woodpecker; nuthatches, all the birds will come, feast, sing, and play in its branches, while a berry remains to be eaten of the delightful repast. So they gather their food, for has not the Lord said, "Behold the fowls of the air; for they sow not, neither do they reap, nor gather into barns; yet your heavenly Father feedeth them."



*Photo by Arthur A. Allen*

Rivals for Chickadee favors

# Sir Downy and Miss Chickadee

ADENA K. BURT

A PLAY FOR FOUR CHILDREN IN PRIMARY GRADES

## ACT I

TIME: December, three o'clock in the afternoon.

PLACE: Playground at back of school building.

CHARACTERS: Downy Woodpecker. Miss Chickadee.

SCENERY: Few trees and feeding station for birds.

Downy Woodpecker flutters in and peeps into the food box with an excited air.

SIR DOWNY. *Oh dear! It's so long since the little children have put any seeds or meat in this box out here and I'm very hungry!*

MISS CHICKADEE (flutters up to box). *My, Oh, my! I ate the last seed two days ago, and those bad little children still forget us.*

*Today I have been flying everywhere and couldn't find a speck of food on any of these big trees or baby trees, but I thought the children might think of us this cold afternoon.*

SIR DOWNY. *Mr. Snowman has been here so much that all the little insect eggs, which I eat are away under his warm coat and it will be a long time before I can get them.*

MISS C. (running around in the trees). *What shall we do, Friend Downy? Mr. Snowman also covered my little seeds in the fields up so long ago I have forgotten where they were.*

DOWNY W. *I'll tell you what we'll do, Miss Chickadee, to make these bad children think of us again.*

MISS C (coming beside Downy). *Please tell me quick! !*

DOWNY W. *When the children come out tomorrow morning and call us, we'll just hide and they won't be able to see us at all. Then maybe they will put some food out here again.*

MISS C. (flutters around with excitement). *That's fine. Now let's go to sleep and wait for the children.*

(They run out together.)

## ACT II

TIME. December 9 o'clock A. M.

PLACE. Same.

CHARACTERS. Downy Woodpecker, Miss Chickadee, Janie and Susan.

SCENE. Same.

JANIE (coming out in playground, looks around, surprised).

JANIE. *Where are all my little birds this morning? Oh, little birds aren't you coming to see me? Please come Sir Downy Woodpecker, and bring your friend Miss Chickadee. I want to see you so badly, before Miss Teacher comes because I want to tell her that I saw you first this morning.*

(Downy and Miss Chickadee peek around from behind the branches.)

DOWNY: *Sh-h-hsh- don't let her see you.*

JANIE (walking backwards). *You are just horrid little birds not to come and see me—(bursts out crying).*

SUSAN (runs in). *Why Janie, what's the matter?*

JANIE. *The—little—birds—won't come to see me.*

SUSAN. *Oh, don't cry any more, but let's see what's the matter.*  
(They go up to box; back away amazed.)

Both together. *Oh, oh, oh—no food! (Janie runs away).*

MISS C. (looking around at Downy). *Now I guess we will get some more good seeds and meat to eat.*

(Janie comes back with hands full of seeds, puts them in box.)

JANIE. *There! Little birds when you smell these, you will come to see us again, but I wouldn't blame you a bit if you didn't. How can I ever tell you how very sorry I am?*

SUSAN. *If you will only come back, we promise never to let you be hungry again.*

(Downy flies down from tree over to box. Miss Chickadee soon follows.)

SIR DOWNY. *I'll come back to you this time, but if you let me go hungry again, I will go and visit some other little girls.* (Downy and Miss C. eat ravenously.)

MISS CHICKADEE (flies to next tree). *See—I'm going to hide some of these seeds in this branch and when I am very hungry I will eat them. These children might forget me again.*

JANIE. *Dear little birds, please don't leave us again, we all love you and really didn't mean to neglect you.*

(Bell rings—children run back to school.)

• *Finis*



*Photo by Anna A. Wright*

## Wild Birds as Pets

ANNA ALLEN WRIGHT

Ithaca, N. Y.

We have been feeding our wild birds this winter, and they have proved the most delightful little friends. I know that you would enjoy having them visit you, and they would be glad to do so, if you would offer them a good dinner. Some day they may eat out of your hand, as they have eaten out of ours, and out of the hands of many who have come to see them here. We have an open sunny balcony, just outside the kitchen windows, and often little chickadees fly through the window and eat raw peanuts from the table. The bay-window of the dining room looks right over the balcony rail, where we put the feeding tray, so that the birds are often in sight while we are eating.

As I sit now beside the window, a little chickadee is swinging in his cocoanut shell basket, not two feet away, another is on the



little pine tree on the balcony post, and a nuthatch is calling as he pecks the suet put into a hole in an old branch. He spreads his wings and tail, points his bill and makes a very cross noise if any sparrow or chickadee tries to interfere with him. In fact, he drives them away if he finds them near the food he wants.

We have five little chickadees that visit us. Just now one took a drink from a dripping icicle, hovering just below it as he drank. When they can't get water, they chew snow, and it takes quite a little to give them a drink. We have a drinking cup out for them, but it freezes so quickly these cold days, that I'm afraid it doesn't do them much good. We keep suet out for them, and chopped raw peanuts, of which all birds are very fond.

When we first began to feed them, they were very greedy, always taking the biggest pieces they could find, flying away to hide them, and then hurrying back for more. Sometimes they hide things now, but more often they stay right here and eat them. The little chickadee takes a piece of nut, tucks it under his foot to hold it and then pecks away at it. The nuthatch will stay to eat small pieces, but if he finds a large one, he carries it away, and thrusts it under a piece of bark and there eats it.

We have a shelf fastened to the rail, on which to feed them, but we also put nuts into the cocconut swing, and also into the swinging cocconut house. You would enjoy seeing a little chickadee alight on this cocconut shell house when it is swinging, jump into one window, take a nut and fly out the opposite window. Besides these things we have two Christmas trees and a shelter made of a crate set on a box and covered with evergreens. On stormy days, they like this shelter. There is a swinging shelf inside for food, and the evergreen branches thrust through the cracks of the crate make many perches where they eat their nuts.

As Christmas day was warm, we opened a window, and by drawing a chair with some nuts on it further and further from the window, and closer and closer to the table, we soon had several little chickadees enjoying their Christmas dinners, one at a time, right beside our own table. As we drew the chair away from the window, the chickadee couldn't see it, and flew to the back of a chair, and looked around. When he discovered the food, he flew to it immediately. He seemed to know it was meant for him. Chickadees have such confiding ways, and will soon investigate any new thing you put out for them!

Another little chickadee that we came to know very well was our little lame chickadee, who had but one foot. We called him "Little Lame Chick." He was one of our first visitors, and early in the fall, when we were offering them many kinds of food, I put a piece of raw pie crust around a branch of the little pine tree. This he enjoyed immensely though I scarcely believe he had been brought up to have pie for breakfast. He soon learned to enjoy the peanuts and you would have enjoyed seeing him hop up and tuck the nut under his one foot so he could eat it. One very cold day soon after Christmas, the little chickadees were holding first one foot then the other up under their feathers to keep them warm. And what was poor "Little Lame Chick" to do? He tried to huddle down and cover his one foot, but it was getting very cold. As he tried to hold to a slanting branch on top of the shelter he kept sliding down. He couldn't hang on. Then he tried another perch, but fell off from this, and fluttered his wings. I went out carefully and with a black cloth in my hand wrapped him up. He seemed surprised, but did not try to get away. I brought him into the house and kept him wrapped up for a little while, then loosened the covering and let him fly around. He was bewildered at his strange surroundings but not frightened. He alighted on the picture frames and curtain rods. After about half an hour, we pulled down the shades and opened one of the dining room windows at the top. He flew to the window top, looked out, flew back to a picture frame to think about it, then decided to go out and away he flew. In ten minutes he was back on the balcony peacefully eating.



*Photo by Anna A. Wright*  
Little Lame Chick

## Nature Study in the Library

BIRD AND FLOWER GUESSING CONTESTS

DELLA MACGREGOR

During the month of April twenty-four pictures of common birds were mounted and displayed in sets of eight per week in the Children's Room of the St. Paul Public Library.

In order that children might have an opportunity to familiarize themselves with the correct bird-names of the specimens exhibited fourteen of the best bird books were made into table reference books and all children entering the contest were urged to look up and verify their identifications in the bird-books before handing in their papers. To stimulate interest in the contest the St. Paul Humane Society gave five dollars for the purchase of books to be awarded as prizes.

One hundred and thirty children entered the contest, only twenty-two of whom dropped out before the contest closed.

Only one, a girl of fourteen, identified all of the birds correctly. Five identified all but one, four all but two, thirteen all but three.

Books were awarded to all of those who named all but two correctly by the Humane Society; through the courtesy of the Department of Entomology of the University of Minnesota pamphlets entitled "Some Useful Birds to be Found in Minnesota," were awarded those who identified all but three correctly.

The children all worked hard and earnestly, some of them spending as much as ten or twelve hours in the identification of the pictures.

The day the prizes were awarded more than one hundred and seventy children came to witness the results of the contest.

Mr. Lange, who is one of our best authorities on bird study gave a short talk on The Calls and Homes of our Common Birds, illustrating his talk with colored slides of many of the birds that had appeared in the contest.

This contest was succeeded during May by a Flower Contest. When the contest closes there will have been twenty-seven pictures of the common wild flowers for identification.

In order that children living in the down town districts who have little or no opportunity for gathering flowers might see the flowers themselves, all children living in the suburbs have been

urged to bring flowers to the library and whenever they do so, and correctly identify the flowers they bring, their names have been entered on "The Roll of Honor." Even boys and girls of twelve and fourteen have entered the contest.

When the contest closes, five dollars worth of books will be awarded as prizes, the money for the books having been donated by the Women's Home Garden Club. In addition to these prizes every child who had entered the contest will receive a package of flower seeds.



## Do You Know?

MARY ELLIS

Buffalo, N. Y.

Do you know that the late fall is the time to start a wild flower box? Get hepatica plants, the bloodroots, the trilliums, Jack-in-the-pulpits, and plant them in your box. Leave it out of doors in some sheltered corner, cover well with leaves and leave it until the month of February when we long for the signs of Spring. Bring it in and watch things grow. Plenty of water is necessary. Strange as it may seem, wild flowers will not grow and blossom well until they have been in frozen ground.

Do you know that it is very interesting to have a puzzle box? While planning for the wild flower box, start another by putting in earth from rich woods, digging down far enough to get roots and bulbs and then see what comes up. It is quite exciting. This box must be hidden away like the other of course.

Do you know that branches of the sumac, with their bunches of berries, hung up about a pole or nailed to a bird house or trunk of a tree will bring the chickadees, the nuthatches and the kinglets?

Do you know that now is the time to be making the bird houses and to be getting them up so that they will have a chance to become weathered and become a part of the landscape so that the birds will not be afraid of them?

Do you know that now is the time to form a Junior Audubon Society? By getting the children acquainted with our winter birds we may be able to save many of our feathered friends from starving to death in the awful blizzards which are bound to come.



## The Autobiography of a California Quail

A Conservation Story from San Jose, California

EDITH M. SINIMAN

Two little children were walking in the stubble field one day down near the creek when they heard someone say quite plainly, "Peek-a-boo, little children, I see you but you can't see me." A pause and then, "I see that you have no dog nor gun nor sharp white teeth shining at me and no big round eyes peering out of bushy feathers nor yet do you come creeping and wriggling on the ground, so if you will sit very quietly on that log there, I will move a little so that you may see me for I should like to be friends with you."

The two little children sat quietly a few moments on the log looking sharply at the ground, when suddenly something moved right at their feet, stood up, and what did they see but a beautiful quail, just exactly the color of the leaves and ground where he stood, very dignified, very graceful with a slender plume nodding on top of his head as he said, "There now, look at me. Wasn't

I clever to talk right at you and yet you couldn't see me? Had you stepped on me even I should not have moved for fear that you might have found my babies who are very near and unable to fly very much yet. Our nest is in a little rounded hollow in the ground close to the fence. It is lined with dried grass and stubble and covered with brush so that while we cannot see out very well neither can anyone else see in very easily. It is a very cozy little home."

"My name is Bob White though people calle me quail because I call out 'Tobacco- to-bac-co' instead of 'Bob-white' as my eastern brothers do. I will tell you later why I always say 'tobacco'. I have lived right here on this very place for a long time, nearly as long as you, little four year old Mary, in fact, I was born here."

"The very first thing that I remember I was tucked away tightly in a tiny, pure white pointed egg and I wanted to stretch. So I tried to but found that I couldn't. Then I pecked at the shell a little and almost immediately someone pecked hard at it on the outside and the first thing I knew there I was, a little baby quail out of the shell with fourteen eggs about me and Mother very busy pecking now one and now another so that in a few hours there were fifteen downy little balls of chestnut and buff colored fluff in the nest with Mother."

"The very next day I was off, with my brothers and sisters after Mother stretching my cramped legs, chirping, looking for worms and seeds and tiny bugs. I noticed that all my brothers were laughing at me. As soon as Mother noticed it, she came over to me picked at my back a little and off fell half of an egg shell. I guess that I must have looked very funny and I had to laugh myself. But I felt better and ran faster than ever, and when Mother caught a nice fat long angle-worm and pecked it into four pieces, I ran up quickly and gobbled one piece up. Then I knew what that empty feeling inside of me meant."

"Mother showed us some good seeds to eat and some bad ones to let alone, then she showed us how to run very quickly and quietly, to fly a little and to do just what I was doing when you came upon me just now—to lie perfectly still in the leaves and hold my gamy scent tightly under my feathers, so that your trained dog, Prince, with his nose only a few feet from me could not find me"

"Every day Mother or Father and sometimes both would take

us for a walk quite early in the morning and we would stay out for hours looking, learning what to eat, eating, drinking, bathing and generally learning how to be useful, honorable, dignified quail citizens, able to find our food, to do something to help the kind farmer who gave us a home, and to protect and care for ourselves both night and day. About noon, we returned home for a nap, to go out again about four o'clock for another meal and another lesson. Then, at night, we all returned near our nest and squatted about in a circle our tails pointed inside the circle and our faces pointed out the better to keep watch for our enemies. Father always slept outside the circle and used to call and warn us to keep quiet if an owl or a snake or a weasel, or coyote or fox or worst of all a man with dog and gun came near.

"Sometimes Father would say very softly,—'weeka-weeka' which meant 'be perfectly still and hold your scent' but when he said 'queet, queet, queet' we knew that meant 'fly' so we spread our little short wings and whirr we flew up very quickly confusing our enemy with our swift noisy motion and besides we all flew away in different directions. We could gather together later when we heard Father call softly 'cha-quah-kah, queet, queet,' for we knew that then Father considered everything safe and we could form our little circle again and try to sleep."

"Oh, little children, promise me now that when you grow up you will not go into the fields with a dog and gun looking for quail for it is very hard for us to get any real rest night or day what with having to sleep always in fear of man or beast. If you will let us make a home on your farm and protect us a little we will promise to eat the insects that kill your fruit and the weed seeds that crowd out your grain and we will never ask for more than the waste grain scattered about your fields."

"Well, little children to go back to my story, before the year passed in which I was born, there had been forty children born in our family, but in November only twenty were left. An old owl caught five, a coyote got two, a fox two and a snake one. Then after the fifteenth of September when man is free to take his dog and gun and hunt us came our most unhappy days. We were frightened all of the time by the banging of the guns and by the nasty smell of the powder. Then a dog was likely to slip up on us at any moment and catch us unawares so that we lived in a state of constant fear and trembling. We were afraid to eat,

afraid to sleep, afraid to drink or bathe and when November came only twenty of us were left."

"Well, the next spring I married when I was just a year old and I have the dearest and best little wife in the world. We raised only two families last year because of the drought but this year we shall have three for Mrs. White is now sitting on her third nest full of eggs. The first nest-full this year she sat on for twenty-four days and brought out twelve lovely babies. A few weeks later she had laid fifteen more eggs in the nest and had to sit on them so I played Mother to the babies and took just as good care of them as she. She hatched the whole fifteen and is now sitting on ten more eggs. I have taken such good care of our babies and people are so good about here and try to keep all of our enemies away so that I have the whole twenty-seven happy about me."

"Do you know old Mrs. Meade who lives on the next ranch? Of course you do. Well she is just as kind to us as she is to you little children and every morning we go over there and eat with the chickens." "This spring, she scattered some grain down in the brush near the creek for us and each day she scattered some a little nearer the house until we got right into the yard with the chickens and were not at all afraid."

"We spend a good deal of time on Mrs. Meade's ranch to pay her for her kindness and that is why she has the best grain and fruit about here. You see we are just like you, children, Mrs. Meade loves children and is good to you so you never think of scaring her chickens or pulling up her flowers or robbing her bird's nests but you do any kindness possible for her just as we do. Each year we help to make her crops better."

### Coming Issues of the Nature-Study Review

Winter Habits of Common Wild Animals	-	-	-	-	January
School Gardens	-	-	-	-	March
Fish and Fish Farming	-	-	-	-	April

The January issue is No. 1 of Vol. XIV. Start new subscriptions at once. \$1.00 per year of 9 issues.



## A Piece of Suet

RUTH MARSHALL

Lane Technical School, Chicago

The initial cost was ten cents. We, three bird lovers, back in the early days of last January, decided that we must feed the birds that winter. Our landlady, like Barkis, being willin', we tied pieces of the suet on the branches of small elm trees in the back yard where they were in view from some of the upper windows. Here they dangled, or the pieces which replaced them (another dime's worth) till the buds had swollen in the spring and the young leaves of May had hidden the last scraps. Once a bone was added, and once a bunch of wild smilax berries found on a winter walk in January.

The food was soon discovered by the birds. The downy woodpecker was the first visitor that we noticed, and the most frequent. Sometimes three or four were there at a time. There were chickadees and nuthatches almost as often. Downy drove the nuthatch away sometimes; and one day I noticed that he (or she) likewise drove away the English sparrows that were always hanging about, but never quite daring to take that perilous swing on the dangling suet. There was hardly a morning throughtout the remainder of the winter when we did not hear the "yank, yank" of the nuthatch at sunrise, or see some fluffy but cheerful bird getting his breakfast at our expense. As dusk fell at the end of the day they were often seen. How many came, and how often, we do not know; for it was only occasionally during those busy days that we could stop to watch them. But it was very alluring, this watching for the birds. Often I seated myself at the typewriter to compose a business letter; or, pad in hand, I tried to finish those belated Christmas notes. Then would come a joyful "chick-a-dee-dee-dee" outside and I must drop everything to watch by the window. Sometimes I seated myself by the other window with the *Outlook* or some other improving literature which needed to be read; but the suet was not in sight and my thoughts would wander. All work in that room had to be done at night when there were no interruptions. Many a day I watched the birds and let the newspaper with its dreary news of the Great War drop from my hand; the world was a good place to live in after all. On Sundays I gave my undivided attention to our boarders. Then I seated myself on the window box in the sunny

east window, and with the bird glasses in hand, forgot for a time the trials and perplexities of the week and lived again!

Our great day was January 16. It was bitterly cold, one of those clear bright sunny days with a biting wind. The mercury was reported twelve below all day. Our back yard was protected and sunny, and here the birds came in numbers. The food must have been a real boon to them, for they came all day long. Scarcely ever, whenever we looked, did we fail to see at least one bird at the suet. It was the biggest success in a feeding experiment that I had ever achieved, and quite as the bird books say it should be. The first caller that we noticed was the white bellied nuthatch, at eight o'clock. He and his kind were there all day long. Then came downy and his relations; and once or twice we were sure we saw the hairy woodpecker. Then to our delight a red-bellied woodpecker was discovered feeding. Now this is not a common bird in the region and it seldom strays into town from the woods. But here it was, all day long, coming and going. I had to go out and replenish the suet. A blue jay was observed in one of the trees, but he took no interest in the suet. I had tied an ear of corn to one of the trees a few days earlier and he took a few kernels of that. The English sparrow came also, like Satan, but he could not quite balance himself on the swaying branches. Six kinds of birds, all on a bleak January day, right at home!

Though this was our biggest day, it was not any more interesting than some others. Often we waded through slush to the woods to try to see some birds, to return, disappointed, to find them in our own back yard feeding on our suet. February 12 was a cloudy day; big flakes of snow were coming softly down upon the ground already well covered with beaten snow. We had taken our lunch to the woods, built a fire and waited for the birds to come; but the woods were strangely silent, and not even the common ones did we see till we reached home, and there they were.

On March 2 the neighbors telephoned to say that a real spring robin was in our back yard. I ran in haste to the window. There he was, looking over the place deliberately as though he had a notion to buy it. Five days later he or some other cock robin found the wild smilax berries which had hung so long unnoticed by the other birds. Downy and the nuthatch were feeding on the suet, but he gobbled down the berries with alacrity. Later on I saw other big plump fellows tasting them. I hung up another

branch, and in a few days the fruit was all gone. About that time the brown creepers began to come to our trees, but they were never observed feeding on the suet.

As spring approached and the snow melted, we thought that the birds would leave us for their natural food. But no; as long as a shred of suet remained the downies and the nuthatches came every day. One day in April a gale was blowing. Downy alighted on the suet still hanging by a long string, and swung round and round and to and fro upon the tattered piece as for the pure joy of the motion. He held on, feasted and then came back for more.

The spring migration came on and absorbed all our leisure time. Many birds came to our yard and alighted on our trees or upon the ground. We saw them or heard their calls, but we never saw them feeding on the suet. A junco came to the suet once in April, just took a look and flew away.

Our last adventure with the suet was along in the latter part of April. One bleak day I was attracted by a curious bunch of something hanging from the underside of the bent limb of a tree.

Closer scrutiny with the bird glasses revealed a ball of ruffled feathers and finally a long slim bill moving about searching the bark. It was a nuthatch. After many moments in that uncomfortable position, it flew to another tree where it remained for some time. It had a curious look; it was strangely quiet and its call was weak. All work was dropped and two bird glasses viewed it from every angle. Its head patches of black were not clearly outlined as in the orthodox white breasted. At first we thought it was sick; but sometimes it would come to the suet, feed vigorously and fly away quite as a nuthatch should. We searched the bird books for another kind of a nuthatch but no description fitted, so we simply called him "Nutty" and decided he was a freak. Later we were sure we were right; for something curious in its attitude led us finally to see that he had but one leg! A friend had already reported a one-legged nuthatch from another back yard, and we concluded that it was the same one. The skill with which the poor creature would hang on to the ragged swinging piece of suet was a source of wonder to us, and he seemed even more fond of hanging head downward than the normal birds. He stayed about for several days.

We watched our suet daily until the last scraps were hidden by the expanding leaves, when even the downies left it.

# THE NATURE-STUDY REVIEW

DEVOTED PRIMARILY TO ALL SCIENTIFIC STUDIES OF NATURE IN  
ELEMENTARY SCHOOLS

Published monthly, except June, July and August. Subscription price, including membership in the American Nature Study Society, \$1.00 per year (nine issues). Canadian postage, 10 cents extra; foreign postage, 25 cents extra.

**Important** Please note date of expiration of your subscription on the label of the wrapper. Subscriptions must be paid in advance to comply with postal requirements. Subscriptions and advertisements should be sent to *The Comstock Publishing Co., Ithaca, N. Y.* Manuscripts for Publication and Books to be Revised should be sent to the Editor.

---

## Editorial

### PRESCRIPTIVE VS. SUGGESTIVE NATURE-STUDY COURSES

A common point of view has been that the course in nature-study should never be other than suggestive, that is, it should not be prescriptive. In the early stages of the nature-study movement, such a course was justified for several reasons: the field was new; the material was plentiful, but untried; the teachers and supervisors were inexperienced.

This type of course of study has given results somewhat as follows: Some schools and communities are doing fine work in nature-study, chiefly those in which the principal is a leader, planning the work for his school. In other schools certain rooms are doing good work. In such case the individual teacher is an enthusiast in nature-study, possibly because she has been well trained in this field, possibly because she has found this subject helpful in the other studies. In other schools the work is neglected, or if done, it is performed in a highly perfunctory manner.

Among the dangers of the suggestive course of study are the following: Such a study cannot compete in the daily program with the studies having required matter. The tendency of the teacher is to fail to make careful preparation in matter that is optional. In such a course of study the steps from poor preparation to neglect and then to omission are few and easily found by many teachers.

The advantages of a prescribed course are these: The teacher can plan her work from term to term. She knows what may reasonably be expected from her. She is encouraged to prepare

herself adequately in a more definite field of the nature study course. As a result of the foregoing, she will find the work more interesting and therefore teach it better.

It would seem then, that the time is at hand when nature-study should be a required subject with a more definitely prescribed content than has heretofore been the practice.

A course may be prescriptive and still be flexible. In such a course for the middle and upper grades, the general theme for a given grade can be stated. The main heads of this theme and the time given to each might be specified. A minimum amount of specific detail should be prescribed under each head. Much other material within the general theme from which the teacher can choose supplementary work should be suggested.

J. A. DRUSHEL.

**NOTICE OF THE ANNUAL MEETING AND THE ELECTION OF OFFICERS OF THE AMERICAN NATURE-STUDY SOCIETY**

The American Nature-Study Society will hold its annual meeting in Pittsburgh, December 27th. The meetings will be held at Pittsburgh University, inquire at the A. A. S. Headquarters for the place of meeting.

The following officers are to be elected: President, five vice-presidents and five directors.

The retiring vice-presidents are: B. M. Davis, E. R. Downing, C. F. Hodge, A. L. Matthews, Alice J. Patterson. The retiring directors are: J. A. Drushel, St. Louis; C. H. Robison, N. J.; S. C. Schmucker, Pa.; G. H. Trafton, Minn.; R. E. Wager, Ill.

Nominations for the above officers should be mailed to the Secretary-Editor before December 20th.

**PROGRAM OF THE ANNUAL MEETING**

**Morning Session, 10:00 A. M.**

- Opportunities for Research in Problems of Teaching Science Elliot R. Downing
- President's Address—The Humanistic Element in Education,  
Liberty Hyde Bailey
- The Spirit of Nature-Study - - - - Cora A. Smith
- Secretary's Report and Election of Officers.

**Afternoon Session, 2:00 P. M.**

- The Scientific Background of Nature-Study Samuel C. Schmucker
- Two Recent Movements of Importance to the Future Development of  
Nature-Study - - - - Anna Botsford Comstock
- The Problem of Using Books for Supplementing Observation Work in  
Nature-Study - - - - Maurice A. Bigelow

Several other people of importance in the Educational Field have tentatively promised to be present and speak on vital phases of Nature-Study.

## Teacher's Corner

The Editor believes that the following letter from a teacher—as to work accomplished—will be of very practical help. It is from Miss Rose Salehli of the McKinley School of Erie, Pa.:

In this day and age, the school curriculum does not confine one to the four walls of the school room nor to books dealing with the three R's. It allows one to enjoy the open, and delve into the Book of Nature which is surely one of the most interesting and instructive of books.

The boys and girls of a third and fourth grade class in McKinley School have started out upon their bird trips as early as six o'clock in the morning. These trips have been taken to a woods within pleasant walking distance of the school. Some of the children came with their breakfasts in their pockets, while others evidently had been eating a hasty bite on the way. Some looked as though they needed a little more sleep, but all signs of sleepiness disappeared when they began to look for birds. It was altogether amusing to watch them. Returning to the school by eight o'clock, the class had an abundance of material for nature study, language, and geography lessons for several days.

On several occasions this class has spent an afternoon—usually Friday—at Waldemeer, a beautiful lake shore resort several miles from the school. This park is a veritable birds' paradise in the early spring. The children make good use of bird glasses, and are usually careful about keeping quiet, though one must expect a few explosions of delight on such a trip. The woodpeckers with their hammerings are particularly fascinating to the boys and girls. Some of the birds they have seen and become familiar with are the brown thrush, red-headed woodpecker, goldfinch, blue-bird, song sparrow, red-winged blackbird, ruby-crowned kinglet, and downy woodpecker. One of the children always carries a note book in which to record the names of all birds seen on the trip.

In the class room in the spring, this class has made a further study of the most common birds of the neighborhood, and discussed bird houses. Just now they have a bird calendar and a flower calendar each in embryo, and they are becoming very enthusiastic over them. The bird calendar is to be in the shape of a bird house with birds flying about it. The flower calendar will be in the shape of a favorite flower. The calendar records will show the names of birds or flowers, when seen, where seen, name of pupil who first saw.

Last fall the children made a study of the leaves of trees and shrubs growing in the vicinity of the school. They also learned to recognize and name such wild flowers as Pearly Everlasting, New York Aster, Heart-leaved Aster, Butter and Eggs, Trillium, Wood Anemone, Queen Anne's Lace, Common Plantain, Showy Goldenrod, Early Goldenrod, New England Aster, Many-flowered Aster, Small White Aster, and Yarrow.

During this past winter these boys and girls made a study of the habits and environments of a number of different animals, and a detailed study of the raccoon.

They also learned about the four constellations: The Seven Sisters, The Bull, Orion, and The Lion. Myths connected with these star groups furnished

the material for reading lessons and for reproduction work in the language lessons. The boys of the class were especially interested in this bit of astronomy.

Last spring, one day while the children were at work in the school room, a beautiful Cecropia moth emerged from the cocoon which we had been watching for weeks. Then the children were told the life story of the moth.

Each boy and girl in this class (which is now beginning the fifth grade) has a garden plot near the school. The interest was so great last year that most of the children visited their gardens and cared for them throughout the summer vacation. A garden supervisor came twice a week to direct the garden work.

Several of the children sold some of their garden produce, and were very proud of the money thus earned.

Each pupil in the class has a "Garden Diary and Composition Book" made in the class room. The covers of different colors are decorated with pictures of vegetables and flowers. In these books, carefully entered with pen and ink, may be found the daily records of the garden work of the past year, also the weather report for each day during the gardening season. When school opened last fall, each pupil wrote in his book an account of the summer's work in the garden. In these books have been written the life story of the cecropia, and the account of an experiment performed in the room to show that plants give off moisture.

During the winter, the class had a number of simple lessons and drawings in elementary botany. They are now getting ready to plant their gardens again. Some of the boys are making boxes, in the Manual Training Department, in which to plant tomato and cabbage seeds. When these plants are removed to the garden plots, the boxes will be filled with flowers and put outside the windows of the school room.

Most of the studies of the class room have been based upon the garden and other nature study work of this class. This experiment has been very successful, especially in arithmetic. The boys and girls have found it easy and interesting to find the perimeter and the area of the garden plots, to find the cost of corn at so much a dozen ears, to measure and weigh vegetables, and make out bills for vegetables, seeds and flowers.

They have not used a text book for spelling at all, but have learned to spell the words they have used in their written work.

Nearly all of the pupils of this class belong to the National Audubon Society, and most of them have attractive bird houses in their back yards. They have learned several poems about birds.

---

#### THE CHICKADEE

The chickadee wears  
A cunning black cap  
In all his affairs,  
The Chickadee wears  
With genial airs  
The dear little chap—  
The Chickadee wears  
A cunning black cap.

The chickadee's song  
Is "Chick-a-dee-dee."  
It is not very long,  
The Chickadee's song,  
Not much in a throng,  
But it satisfies me,  
The Chickadee's song  
Is "Chick-a-dee-dee."

## News Notes

### CALIFORNIA

The California Audubon Society—whose president is Dr. David Starr Jordan—and whose secretary is Mrs. Harriet Williams Meyers—has just issued a very important leaflet upon "Blackbirds, Robins, Meadowlarks and Flickers. Shall we kill them?"

An intelligent understanding of the injuries done by these birds and the benefits conferred by them shows a decided balance to their credit.

### CONNECTICUT

*Hartford*—The Year Book of the Hartford Bird Study Club makes you know you would like to live in Hartford. So attractive an outline of a year's work in a Bird Club has never come within the notice of the news editor.

The spirit of the Club is expressed on the first page with Ruskin's thought: "The greatest thing a soul ever does in this world, is to see something and tell what it saw in a plain way." The subjects of the bi-monthly programs are inspiring and must keep the members in a state of joyful anticipation, even in these troubled times. The meetings must be like an oasis. Even in the mere list of committees you can almost hear the birds singing. In addition to ordinary, prosaic committees like membership and Executive and Programs, there are Field, Protection, and Sanctuary Committees. The subjects of the meetings include "Our Club," "The Lure of the Swamp," "Boy Scouts Following the Trail," "Annals of a Quiet Neighborhood." "Insects," "Christmas Bird Census," "New Year's Lists," "Homes Without Hands," "When Day Breaks," "Notes of the Night," "Birds in Poetry and Art," "Fossil Birds," "Roll Call—Two Minute Field Experiences." And at the end of this delectable feast for nature lovers they say: "The love of Nature is a great gift, and if it is frozen or crushed out, the character can hardly fail to suffer from the loss."

### ILLINOIS

*Chicago*—The National Crop Improvement Committee under the direction of Mr. Bert Ball is taking practical steps to have all the corn planted in Illinois tested by school children. The following is an excerpt from a letter to the public:

"By having the children make these tests in school, if the seed corn, as it will, should be found deficient, more vigorous measures will be taken by the farmers' clubs and local committees.

"By seed testing alone we should be able to add 10 bushels to the yield of the average acre of corn, and where there are 100,000 acres of corn 10 bushels per acre would mean a million bushels which would sell, at present prices, for more than two million dollars. This our children could do for their country with very little effort."

Sent out with this is a graphic circular describing methods of testing corn.

*Macomb*.—A very important number of the *Normal School Quarterly* is given to the results achieved by Professor Charles W. Finley and his pupils



in studying the birds on the campus of the Western Illinois Normal School. It includes dates for Spring migration of 86 species, and a list of residents and transients. There were 208 nests built on the campus; observations were made on many and the notes given. Most important feeding records on six species are added. Eleven full paged and pertinent illustrations complete one of the most valuable and inspiring contributions to bird study made in any institution of learning in America..

#### MISSOURI

The 63d meeting of the St. Louis Section of the American Nature Study Society was held in Harris Teachers College, September 12. This Section is a hot wire in nature study and the following report of the meeting was sent by the Secretary:

The following were elected officers for the coming year: President, Mr. C. H. Sackett, Junior High School; Secretary-Treasurer, J. A. Drushel, Harris Teachers College; Members of Executive Committee, Miss Mary Andrew, Wyman School, Mr. W. J. Stevens, Field School.

Mr. Shackelford holds over another year as Director.

We had a splendid meeting, best for several years. Short reports on nature-study experiences were made by Mr. Grier, Mr. Shackelford, Mr. Dougan, Miss Windhoist, Miss Becker, Miss Glatfelter.

Three field trips were planned for this autumn's work.

#### NEW HAMPSHIRE

The Audubon Society of New Hampshire has through its Secretary, Manley B. Townsend, sent out a stirring appeal for help and co-operation in saving the birds from wanton destruction.

#### NEW JERSEY

The Somerset Hills Bird Club through its president, J. Dryden Kuser, has issued an interesting circular which discusses the history of the club, its present activities and future plans; the latter are broad in scope and most practical and workable; they include Educational Work in Schools; Aid to the League of American Sportsmen in its Attempt to reduce the number of English Sparrows; Winter Feeding; Nesting Boxes and the Liberation of Native Game Birds.

#### NORTH CAROLINA

WINSTON-SALEM, N. C., July 28, 1917.

REPORT ON THE WINSTON-SALEM AUDUBON SOCIETY BY H. W. FOLT

Our May meeting was held on the lawn of Mr. and Mrs. H. W. Foltz on West Second Street. There was a very large attendance including several visitors, and three new members were added to our roll. This was our first out-door meeting and it was so thoroughly enjoyed by all present that we decided to hold more of them. We met at 4.30 p. m., Dr. Schallert, the President presiding. After the business had been attended to, Dr. Schallert read a very gratifying report of our Society from the last Annual Report of the National Audubon Societies. He also told us of his experiences in providing nesting boxes for the birds at his home.

Our host and hostess then conducted the company over their spacious grounds of several acres, where we were shown the nests of various birds, including, Robin, Cardinal, Thrush, Catbirds, Bluebirds and Carolina Wrens, some on trees and bushes, some in nest boxes, and some in their back piazza. Also a goodly number of birds were seen and heard during the evening, and they seemed to fear no danger from the gathered company. We returned by way of some well laden service berry and cherry trees, the delicious ripe fruit of which constrained us to linger long by the way, and when we finally reached the lawn again we were refreshed with most excellent lemonade before we adjourned to our homes.

Our June meeting was held with our enthusiastic members Mr. and Mrs. Craigen at their beautiful new home north-west of the city near Reynolda. The afternoon was warm but clear, and a goodly number were in attendance. We first adjourned to the fine springs at the foot of a steep hill north of the dwelling, and after drinking of the excellent water, we started on our tramp of a half mile through the woods and fields, along streams of running water bordered with beautiful ferns and wild flowers of many varieties, the latter being explained to us by our botanical friend Dr. Schallert.

Among the birds nests found and examined, we remember especially one of a Chipping Sparrow in an old apple tree, a Chewink whose nest with five brown spotted eggs was right on the ground, a nest of Flycatchers on a dog-wood limb was so full of fluffy youngsters that it seemed to be over-flowing, a Mourning Dove was sitting on her two cream white eggs in a rough looking nest in a wild plum tree, but she flew away at our approach. When we returned to the house, almost every lady had quite a collection of wild flowers and medicinal herbs.

Sitting on the large front piazza in the cool evening breeze, the business session was attended to and then we bid our kind hosts adieu, and the motor cars sped away to our city homes.

We have a number of Junior Audubon Societies organized in our City schools, and some of them are doing splendid work. We are going to try to extend our work to the country schools this fall and hope to have good results.

#### PENNSYLVANIA

*Eric*—The sixteen girls at the Eric Elmwood Home for Juvenile Court Girls this summer made a part of their 100 acre farm into a very successful market garden, under the direction of Miss Honora M. Whalen, a recent graduate of the Pennsylvania State College in Agriculture. They worked very faithfully raising berries and all kinds of vegetables which they systematically canned and dried for the winter supply of the Home. All surplus was marketed to regular weekly customers in the city. But best of all, they received their first lessons in nature study, learning of the birds and insects and flowers as they worked. The public spirited citizens responsible for this Home are pleased with the effect of nature study already visible in the lives of these girls.

*Pittsburgh*—Miss Emma Davis, who taught with Professor Schmucker last summer in the Chautauqua School of Nature Study, is teaching this year in one of the Pittsburgh schools which is operated on the Gary plan.

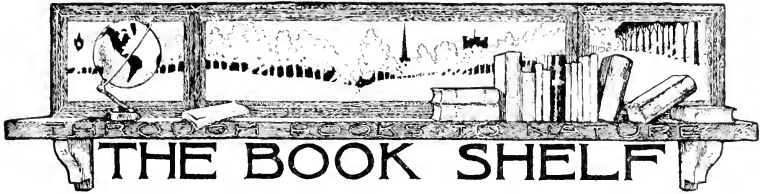

*Bird Friends.* Gilbert H. Trafton, Professor of Biology, Mankato Normal School, Minn. 320 pp., plentifully and attractively illustrated. Houghton Mifflin Co. \$2.00.

"A Complete Bird Book for Americans" is the ideal which Professor Trafton had in mind when writing this book; and he has attained his ideal to a far greater extent than do most of us. This book makes for intelligence on every phase of the bird problem. However, its importance and value to teachers appeals especially to us. It discusses bird travelers, the music, the homes, the nesting habits, the colors and plumage of birds, how to know them, their economic value, their enemies, their protection, how to attract them and feed them and last of all and very important, a chapter on teaching bird protection in the schools; this discusses the purposes and materials for bird study, bird-games and calendars, field trips, bird clubs, the relation of bird study to other school subjects and an outline of bird study by grades and seasons which ends in a series of very practical lessons.

Professor Trafton writes lucidly and terseley and has therefore been able to condense a very great deal of information into this book and it should be on the reference shelves of every teacher in America.

*The Natural History of Chautauqua.* Professor Vaughan MacCaughey, Teacher of Natural History in the Chautauqua Summer Schools. 135 pp. B. W. Huebsch. \$1.00.

For all Chautauqua lovers, here is a most valuable and interesting book and seldom has any book given the Editor such keen pleasure; for she too once taught nature-study at Chautauqua and thus is able to appreciate the great value of this natural history survey of the Chautauqua grounds. It covers the summer birds of Chautauqua and a key for their determination, a list of and a key to the trees, a list of the shrubs, the flowering plants, the insects, the mammals, the fishes in the brooks and in the lake, the frogs, toads and salamanders, snakes and turtles, a synopsis of the ferns and a list of the mushrooms, a synopsis of the common rocks and even an account of the stars of the Chautauqua summer sky. In addition there are very interesting chapters on the geologic history of the region and an account of its early settlement and agricultural development. The book closes with an enlightening chapter on the Place of Natural History in the Educational Program. If we ever visit Chautauqua again, this book will surely be our close companion during every waking moment.

*Bird Houses Boys Can Build.* Albert F. Siepert. Assistant Professor of Manual Arts, Bradley Institute, Peoria, Ill.

Professor Siepert is accustomed to tell pupils how to make things as this pamphlet will show. He gives working drawing of—placing boxes for woodpecker, bluebird, wren, chickadee, robin, flycatcher, martin, finch, also for suet feeder, food shelter, feeding shelf, bird baths. The directions are clearly written and the illustrations are many and attractive.

*Our Backdoor Neighbors.* Frank C. Pellett. 209 pp. with 84 illustrations. The Abingdon Press. Price \$1.50.

Lovers of nature everywhere should enjoy this new book by Mr. Pellett. He speaks to us in a most entertaining manner from an acquaintance of many years with our feathered, furred, and insect friends. No back-yard gossip ever fell on more eager ears than that that came to the author from "Foxy," or "Bunny Cottontail," or "The Jolly Old Crow." True to the tradition of a gossip the author has passed on to us the messages from these lower creatures in a most interesting manner in his stories of their home life, adventure and behavior. Like a sympathetic and true neighbor the author neglects not so speak a good word for those creatures who justly or unjustly have attained a reputation of bad repute such as "The Red-tails," "The Chicken Thief," and "The Polecat." Nature-study will receive an important stimulus from this book of Mr. Pellett's, and young and old will enjoy it alike.

H. E. EWING.

### TO OUR SUBSCRIBERS

Please note your expiration date and send in your renewals promptly.

Owing to the increased cost of paper and printing, also to the fact that The Nature-Study Review has not raised its subscription price, we will print only enough magazines each month to cover the subscription list and its normal increase.

A blue check on the wrapper indicates that your subscription expires with this number.

INDEX

---

THE  
NATURE-STUDY  
REVIEW

---

Volume XIII, 1917

---

ANNA BOTSFORD COMSTOCK  
SECRETARY-EDITOR  
CORNELL UNIVERSITY

PUBLISHED BY  
THE COMSTOCK PUBLISHING CO.  
ITHACA, N. Y.

## INDEX TO VOLUME XIII, 1917

Jan., pp. 1-39; Feb., pp. 41-81; Mar., pp. 83-126; April, pp. 127-169; May, pp. 171-215; Sept., pp. 217-270; Oct., pp. 277-321; Nov., pp. 323-365; Dec., pp. 367-410.

[Names of contributors are printed in small capitals. Abbreviated titles of books reviewed are in quotation marks.]

- "Agassiz as a Teacher," Lane Cooper 364  
 Agreement as to the Nature-Study Program, J. G. Needham, 2  
 Agricultural Nature-Study, A. W. Nolan, 346  
 ALEXANDER, W. P., The Goat—An Appreciation, 107; To Louis Agassiz Fuertes, 142; The Twin-Flower, 147; The Bluebird, 184; Sir Frost and the Trees, 297; Hermit Thrush Brook—A Nature-Study Rubaiyat, 329; To the Snow Bunting, 379  
 ALLEN, ELSA G., Concerning Wild Ducks, 171; Color Key to the Ducks of the Eastern United States, 177  
 American Attitude Toward Flowers, The, L. H. Bailey, 135  
 "American Forestry," 321  
 Animal Folk in the Meadow, Jane M. Beilby, 117  
 "Animal Micrology," Michael F. Guyer, 214  
 Annual Meeting and Election of Officers, 42  
 April, Phoebe Bird, 163  
 Autobiography of a California Quail, The, Edith M. Siniman, 395  
 AVERILL, ANNA B., Winter Twilight, 78  
 "Backdoor Neighbors, Our," Frank C. Pellett, 410  
 BAILEY, ELMER J., My Tree, 277  
 BAILEY, GUY A., Nature-Study and Humaneness, 90; The Wild Flowers and the Teachers, 148; Bird Protection, 204  
 BAILEY, H. D., The White Rat as a Pet, 83  
 BAILEY, LIBERTY H., Greeting to the Nature-Study Teachers, 1; The Great Lover, 43; The American Attitude Toward Flowers, 135; The Brook, 323; The Memories in Weeds, 378  
 BARD, CATHERINE, A Brook Acquaintance, 62  
 BARKER, EDNA L., The Royal Moccasin Flower, 131  
 BARKER, E. EUGENE, Royalty in the Plant Kingdom, 127  
 BARROWS, H. P., "Judging Horses," 213  
 BEILBY, JANE M., Animal Folk in the Meadow, 117  
 Bird Founts in the Garden, Mathilde Schlegel, 197  
 "Bird Friends," Gilbert H. Trafton, 409  
 Bird House Contest for 1917, Rules for, Y. M. C. A. of Erie, Pa., 196  
 "Bird Houses Boys Can Build," Albert F. Siefert, 410  
 Bird Houses Injure Trees, Stationary, Parmalee Evans, 200  
 Bird Island, A Visit to, L. B. Cushman, 196  
 Bird Neighbors, Our Most Intimate, Laura A. L. Turner, 188  
 Bird Notes, 191  
 Bird, Phoebe, April, 163; Spring in the Swamp, 203  
 Bird Protection, Guy A. Bailey, 204  
 "Bird Study Book, The," T. Gilbert Pearson, 212  
 Bird Work in the Ethical Culture School of New York City, Myrtle B. Boice, 202  
 Birds as Pets, Wild, Anna A. Wright, 390  
 Birds Feed on in Winter, What, Harriet Reynolds, 383  
 "Birds, Our Common," D. W. Hamilton, 212  
 Birds, What to do When Studying, Ora Sweet, 195  
 "Birds Worth Knowing," Doubleday Page & Co., 275  
 Black-throated Blue Warbler, The Nest of the, Dorothy K. Cleveland, 199  
 Bluebird, The, W. P. Alexander, 184  
 BOICE, MYRTLE B., Bird Work in the Ethical Culture School of New York City, 202  
 "Book of Forestry, The," Frederick F. Moon, 169  
 Botanizing in the Fall and Winter Months, R. W. Shufeldt, 13

- Boy's Account of His Tame Crow, Jack, A, Robert Parsons, 193
- Boy's Friendly Tree, A, George H. Russell, 306
- Boy Scouts to Combat Shelf Fungi, 280
- BRITTON, MRS. N. L., A Schedule for Arbor Day Compositions on Conversation, 140
- Brook Acquaintance, A, Catherine Bard, 62
- Brook and I, The, Mary Rogers Miller, 336
- Brook, How to Study a, Anna B. Comstock, 337
- Brook I Found When on the Trail of the Wild Flowers, The, Lucy L. Stratton, 331
- Brook-Loving Architects, Some, Harry G. Bull, 332
- Brook, Making a Map of the, 340
- Brook, The, L. H. Bailey, 323
- Brown, Bliss S., "Modern Fruit Marketing," 169
- BULL, HARRY G., Ho! for Hepaticas, 157; Some Brook-Loving Architects, 332
- BURNHAM, STEWART H., Glenwood Brook, 357
- BURROUGHS, JOHN, Editorial, 206
- BURT, ADENA K., Sir Downey and Miss Chickadee, 388
- Butterflies, Some Familiar, R. W. Shufeldt, 255
- Butterflies, The Common, Anna B. Comstock, 217
- "Butterflies Worth Knowing," Clarence M. Weed, 276
- CADY, B. C. and V. M., "The Way Life Begins," 125
- CALVERT, A. N. and P. P., "A Year of Costa Rican Natural History," 364
- Chickadee Friends, Three, Annie Linn, 367
- Chrysopas, or Golden Eyes, The, Roger C. Smith, 261
- City Girl's Story of Her Friend, Miss Maple Tree, A., Agnes C. Hogan, 308
- Clean Furrow, A, J. G. Needham, 265
- CLEVELAND, DOROTHY K., The Nest of the Black-throated Blue Warbler, 199
- Color Key to the Common Butterflies, Helen M. Hess, 244
- Color Key to the Ducks of the Eastern United States, Elsa G. Allen, 177
- Columbine, The, Jay R. Traver, 136
- COMSTOCK, ANNA B., The Old Pine Tree's Story, 24; January Nature-Study, 29; February Nature-Study, 69; Feeding Table Notes, 201; The Common Butterflies, 217; How to Study a Brook, 337
- CONNOLLY, LOUISE, A Reading of the Nature-Study Barometer, 97
- Conservation of Wild Life, 58
- COOPER, LANE, "Agassiz as a Teacher," 364
- COVILLE, FREDERICK V., How the Plants Wake up from Winter Sleep, 143
- COX, LUCY E., "Experimental Plant Physiology," 169
- CRANDALL, LEE S., "Pets, Their History and Care," 364
- Crow Babies, Dora B. Haines, 380
- CROWELL, H. S., The Old Willow Tree, 302
- DEARNESS, JOHN, Editorial, 358
- DEKAY, CHARLES, Song, 1
- DeSachet, A Pet Skunk, Harry H. Knight, 93
- Diplomacy of the Good Teacher, The, John W. Spencer, 22
- DOWNING, Dr. ELLIOT R., 41
- Do You Know?, Mary Ellis, 394
- DRUSHEL, J. A., A Note on the Hibernation of the Pupa of the Sphinx Moth, 271; Editorial, 402
- DRYDEN, JAMES, "Poultry Breeding and Management," 168
- Ducks, Concerning Wild, Elsa G. Allen, 171
- DUFF, JAMES LEO, To a Wood-Rat, 103
- Editorial, John Burroughs, 206
- Editorial, John Dearness, 358
- Editorial, J. A. Drushel, 402
- ELLIS, MARY, Do You Know?, 394
- Elm, The White or American, Lewis B. Hendershot, 298
- EMERSON, ALFRED, A Willy-Nilly Stepmother and Other Disasters, 198
- EVANS, PARMALEE, Stationary Bird Houses Injure Trees, 200
- "Experimental Plant Physiology," Lucy E. Cox, 169
- Extracts from Bulletin of the Massachusetts Fish and Game Protective Association, 11
- February Hush, The, T. W. Higginson, 21
- February Nature-Study, Anna B. Comstock, 69

- Feeding Table Notes, Anna B. Comstock, 201
- Fishing in Winter, Matilde Schlegel, 112
- FUERTES, LOUIS AGASSIZ, Humming-birds, 181
- Fuertes, To Louis Agassiz, W. P. Alexander, 142
- FUNKHOUSER, W. D., A Funny Family, 266
- Funny Family, A, W. D. Funkhouser, 266
- Glenwood Brook, Stewart H. Burnham, 357
- Goat—An Appreciation, The, W. P. Alexander, 107
- "Grandest Bird of the American Continent, The," A. McIlhenny, 37
- Great Lover, The, L. H. Bailey, 43
- Greeting to the Nature-Study Teachers, L. H. Bailey, 1
- GUYER, MICHAEL F., "Animal Micrology," 214
- HAINES, DORA B., Crow Babies, 380
- HAMILTON, D. W., "Our Common Birds," 212
- HARDING, MRS. EDWARD, "The Book of the Peony," 213
- HENDERSHOT, LEWIS B., The White or American Elm, 298
- Hermit Thrush Brook, Martha Quick, 325
- Hermit Thrush Brook—A Nature-Study Rubaiyat, W. P. Alexander, 329
- HESS, HELEN M., Color Key to the Common Butterflies, 244
- HIGGINSON, T. W., The February Hush, 21
- "History of Science, The," Walter Libby, 276
- Ho! for Hepaticas, Harry G. Bull, 157
- HOGAN, AGNES C., A City Girl's Story of Her Friend, Miss Maple Tree, 308
- HOLTZ, F. L., Standardizing Nature-Study, 52
- How the Plants Wake up from Winter Sleep, Frederick V. Coville, 143
- Hummingbirds, Louis Agassiz Fuertes, 181
- INGERSOLL, ERNEST, "Primer of Bird Study," 212
- January Nature-Study, Anna B. Comstock, 20
- January Wild Flowers, 139
- "Judging Farm Animals," Charles S. Plumb, 126
- "Judging Horses," H. P. Barrows, 213
- KANE, FLORENCE J., Nature-Study in Milwaukee and its Vicinity, 4
- KNIGHT, HARRY H., DeSachet, A Pet Skunk, 93
- Larch or Tamarack, a Tree of the Swamps, The, Jay Traver, 341
- Leaf Prints, 295
- Leaves from a January Note Book, 19
- LEISTER, C. W., The Chestnut-sides Warbler, 191; The Story of a Sycamore, 304
- LIBBY, WALTER, "The History of Science," 276
- LINN, ANNIE, Three Chickadee Friends, 367
- LIVERMORE, MADELINE A., The Story of Vanishing Brook, 353
- LOESCH, MARY, The Red-headed Woodpecker, 66
- Lombardy Poplar, The, Margery B. Loughran, 27
- LORD, RUSSEL R., A Wise Old Oak, 282
- LOUGHRAN, MARGERY B., The Lombardy Poplar, 27
- MACCAUGHEY, VAUGHAN, "The Natural History of Chautauqua," 409
- MACGREGOR, DELLA, Nature-Study in the Library, 393
- McILHENNY, A., "The Grandest Bird of the American Continent," 37
- Memories in Weeds, The, L. H. Bailey, 378
- "Messages of Good Cheer," The Trotty Veck Messengers, 168
- MILLER, MARY ROGERS, The Brook and I, 336
- "Modern Fruit Marketing," Bliss S. Brown, 169
- MOON, FREDERICK F., "The Book of Forestry," 169
- Mountain Laurel, Leah Wheeler, 59
- Mourning-Cloak, Some Disguises of the, Harriet A. Wickwire, 252
- "Much Crops," A. F. Wilkinson, 364
- "Natural History of Chautauqua, The," Vaughan MacCaughey, 409
- Nature Lover, The, George B. Staff, 190
- Nature-Study and Humaneness, Guy A. Bailey, 90
- Nature-Study in the Library, Della MacGregor, 393
- Nature-Study in Milwaukee and its Vicinity, Florence J. Kane, 4
- Necessity for Greater Accuracy in Describing American Trees, R. W. Shufeldt, 288



- NEEDHAM, J. G., Agreement as to the Nature-Study Program, 2; A Clean Furrow, 265  
 Newark Museum, The, 61  
 News Notes, 119, 210, 272, 318, 406  
 NOLAN, A. W., Agricultural Nature-Study, 346  
 NORTON, ELIZABETH M., Purple Martins and the Boll Weevil, 195  
 Notes from Correspondents, 81  
 Notes on New York Meeting, 51  
 Notice and Program of the Annual Meeting, 403  
 Oak, The, Donald Thistle, 287  
 "Old Crow Stories," Katherine B. Judson, 320  
 Old Pine Tree's Story, The, Anna B. Comstock, 24  
 On the Wind in February, Christina G. Rossetti, 42  
 PALMER, E. L., The Skunk Cabbage, a Swamp Hostelry, 132  
 Parent-Teacher's Association Interested in Birds, A, Margaret F. Small, 200  
 PARSONS, ROBERT, A Boy's Account of His Tame Crow, Jack, 193  
 PEARSON, T. GILBERT, "The Bird Study Book, 212"  
 PELLETT, FRANK C., "Our Backdoor Neighbors," 410  
 "Peony, The Book of the," Mrs. Edward Harding, 213  
 Pet Pine Snake on a Wisconsin Farm, A, Karl P. Schmidt, 104  
 "Pets, Their History and Care," Lee S. Crandall, 364  
 Piece of Suet, A, Ruth Marshall, 399  
 Plan for the Study of the Elm Tree in Primary Grades, A, Susan B. Sipe, 55  
 "Plant Materials of Decorative Gardening," William Trelease, 321  
 PLUMB, CHARLES S., "Judging Farm Animals," 126  
 "Poultry Breeding and Management," James Dryden, 168  
 "Primer of Bird Study," Ernest Ingersoll, 212  
 Purple Martins and the Boll Weevil, Elizabeth M. Norton, 195  
 QUICK, MARTHA, Hermit Thrush Brook, 325  
 Reading of the Nature Study Barometer, A, Louise Connolly, 97  
 Red-headed Woodpecker, The, Mary Loesch, 66  
 REYNOLDS, HARRIET, What Birds Feed on in Winter, 383  
 Robin Annals, Some, Georgia Sweetland, 192  
 ROGERS, JULIA, "Trees Worth Knowing," 275  
 ROSSETTI, CHRISTINA G., On the Wind in February, 42  
 Royal Moccasin Flower, The, Edna L. Barker, 131  
 Royalty in the Plant Kingdom, E. Eugene Barker, 127  
 RUSSELL, GEORGE H., A Boy's Friendly Tree, 306  
 Schedule for Arbor Day Compositions on Conversation, Mrs. N. L. Britton, 140  
 SCHLEGEL, MATHILDE, Fishing in Winter, 112; Bird Founts in the Garden, 197  
 SCHMIDT, KARL P., A Pet Snake on a Wisconsin Farm, 104  
 SCHUFELDT, R. W., Botanizing in the Fall and Winter Months, 13; Some Familiar Butterflies, 255; Necessity for Greater Accuracy in Describing American Trees, 288  
 SCHUMUCKER, S. C., Spontaneity in Nature-Study, 48  
 SIEPERT, ALBERT F., "Bird Houses Boys Can Build," 410  
 SINIMAN, EDITH M., The Autobiography of a California Quail, 395  
 SIPE, SUSAN B., A Plan for the Study of the Elm Tree in Primary Grades, 55  
 Sir Downey and Miss Chickadee, Adena K. Burt, 388  
 Sir Frost and the Trees, W. P. Alexander, 297  
 Skunk Cabbage, A Swamp Hostelry, The, E. L. Palmer, 132  
 SMALL, MARGARET F., A Parent-Teacher's Association Interested in Birds, 200  
 SMITH, ROGER C., The Chrysopas, or Golden Eyes, 261  
 Snow Bunting, To the, W. P. Alexander, 379  
 Song, Charles DeKay, 1  
 SPENCER, JOHN W., The Diplomacy of the Good Teacher, 22  
 Sphinx Moth, A Note on the Hibernation of the Pupa of the, J. A. Drushel, 271  
 Spontaneity in Nature-Study, S. C. Schumucker, 48  
 Spring in the Swamp, Phoebe Bird 203  
 Spring Wild Flowers, The, Lucy L. Stratton, 150

- STAFF, GEORGE B., *The Nature Lover*, 190
- Standardizing Nature-Study, F. L. Holtz, 52
- STRATTON, LUCY L., *The Spring Wild Flowers*, 150; *The Brook I Found When on the Trail of the Wild Flowers*, 331
- SWEET, ORA, *What to do When Studying Birds*, 195
- SWEETLAND, GEORGIA, *Some Robin Annals*, 192
- Sycamore, *The Story of a*, C. W. Leister, 304
- Teacher's Corner, *The*, 122, 161, 270, 313, 360, 404
- Texas Farmers Seek to Save the Mourning Dove, *The*, 81
- THISTLE, DONALD, *The Oak*, 287
- Thrush Family, *The*, Gilbert H. Trafton, 185
- TRAFTON, GILBERT H., *The Thrush Family*, 185; *"Bird Friends"*, 409
- TRAVER, JAY R., *The Columbine*, 136; *The American Larch or Tamarack, a Tree of the Swamps*, 341
- Tree, My, Elmer J. Bailey, 277
- "Tree Talk," 321
- "Tree Wounds and Diseases," A. D. Webster, 214
- "Trees Worth Knowing," Julia Rogers, 275
- TRELEASE, WILLIAM, *"Plant Materials of Decorative Gardening"*, 321
- Trotty Veck Messengers, *The "Messengers of Good Cheer"*, 168
- TURNER, LAURA A. L., *Our Most Intimate Bird Neighbors*, 188
- Twin-Flower, *The*, W. P. Alexander, 147
- Vanishing Brook, *The Story of*, Madeline A. Livermore, 353
- Warbler, *The Chestnut-sided*, C. W. Leister, 191
- "Way Life Begins, *The*," B. C. Cayd and V. N. Cady, 125
- WEBSTER, A. D., *"Tree Wounds and Diseases"*, 214
- WEED, CLARENCE M., *"Butterflies Worth Knowing"*, 276
- WHEELER, LEAH, *Mountain Laurel*, 59
- White Rat as a Pet, *The*, H. D. Bailey, 83
- WICKWIRE, HARRIET A., *Some Disguises of the Mourning-Cloak*, 252
- "Wild Animal Stamp Primer," 79
- Wild Flowers and the Teachers, *The*, Guy A. Bailey, 148
- "Wild Flowers Worth Knowing," Doubleday Page & Co., 275
- WILKINSON, A. F., *"Muck Crops"*, 364
- Willow Tree, *The Old*, H. S. Crowell, 302
- Willy-Nilly Stepmother and Other Disasters, A, Alfred Emerson, 198
- Winter Twilight, Anna B. Averill, 78
- Wise Old Oak, A, Russell R. Lord, 282
- Wood-Rat, *To a*, James Leo Duff, 103
- WRIGHT, ANNA A., *Wild Birds as Pets*, 390
- "Year of Costa Rican Natural History, A," A. N. and P. P. Calvert, 364





MBL WHOI LIBRARY



WH 1ARH I

12986

