



# Oceanus<sup>®</sup>

Spring 1975, Volume 18, Number 3

William H. MacLeish, *Editor*  
Johanna Price, *Assistant Editor*  
Geno Ballotti, *Publishing Consultant*

## *Editorial Advisory Board*

Daniel Bell  
James D. Ebert  
Richard C. Hennemuth  
Ned A. Ostenso  
Mary Sears  
Athelstan Spilhaus  
H. Bradford Washburn

Published quarterly by Woods Hole Oceanographic Institution, Woods Hole, Massachusetts 02543. Application for second-class postage pending at Woods Hole, Massachusetts. Copyright ©1975 by Woods Hole Oceanographic Institution.

Editorial correspondence: *Oceanus*, Woods Hole Oceanographic Institution, Woods Hole, Massachusetts 02543. Telephone (617) 548-1400.

Subscription correspondence: All subscriptions and single-copy orders and change of address information should be addressed to *Oceanus*, 2401 Revere Beach Parkway, Everett, Massachusetts 02149. Checks should be made payable to Woods Hole Oceanographic Institution. Annual subscription, \$8.00; single copy, \$2.25; foreign subscription, \$10.00. When sending change of address, please include mailing label.

# Contents

## *EARLY HISTORY OF UNDERWATER PHOTOGRAPHY*

*by Allyn C. Vine*

*What began in 1939 as an "aside" became, by 1948, an effective means of ocean research. 2*

## *SEA-FLOOR PHOTOGRAPHY: EQUIPMENT AND TECHNIQUES*

*by C. L. Buchanan*

*A review of current systems and their applications. 11*

## *FUTURE DEVELOPMENTS IN DEEP-SEA IMAGING*

*by Robert B. Patterson*

*Likely trends in optical and acoustic imaging. 17*

## *BIOLOGICAL APPLICATIONS OF UNDERWATER PHOTOGRAPHY*

*by John D. Isaacs and Richard A. Schwartzlose*

*With free-vehicle cameras, scientists can study the nature and behavior of deep-sea creatures. 24*

## *PHOTOGRAPHY FROM A SUBMERSIBLE DURING PROJECT FAMOUS*

*by Robert D. Ballard*

*Cameras recorded firsthand observations at an active zone of sea-floor spreading. 31*

## *IMPROVING THE USEFULNESS OF DEEP-SEA PHOTOGRAPHS WITH PRECISION TRACKING*

*by Robert D. Ballard*

*Careful storing and indexing are not enough. 40*

## *PHOTOGRAPHIC CLUES TO THE ORIGIN OF EARTH'S OLDEST OCEANS*

*by W. B. Bryan*

*From micrographs of submarine lavas to spacecraft photos of the Earth and Moon, photography is used to study volcanic activity in geologic evolution. 44*

## *TV IN DEEP-OCEAN SURVEYS*

*by William D. Siapno*

*Closed-circuit TV is an important, economical means of exploring the ocean bottom for mineral resources. 48*

*Cover photos: Sea anemones, shrimp, crab, and worm tubes. Hydrographer Canyon, New England continental slope, approximately 720 meters.*



*R/V Atlantis carrying the working sails used so often in normally encountered seas. During the years 1938-42, several photographic techniques were developed and many underwater photos were taken from Atlantis at depths of 100 to 500 m.*

# Early History of Underwater Photography

Allyn C. Vine

*All men by nature desire to know. An indication of this is the delight we take in our senses; for even apart from their usefulness they are loved for themselves; and above all others the sense of sight. For not only with a view to action, but even when we are not going to do anything, we prefer seeing (one might say) to everything else. The reason is that this, most of all the senses, makes us know and brings to light many differences between things.*

Aristotle

Throughout history, for both pleasure and work, man has dived to shallow depths in the sea and has acquired certain impressions of what is there, or what is not there. In recent years the availability of cameras and self-contained diving equipment has resulted in an enormous amount of high-quality still and movie photography—some taken for pleasure, some for science, and some for commercial applications. In the deep ocean, however, the visual secrets have been much better guarded, partly because of a lack of interest and partly by lack of technology. Only in the last generation have the eye and the camera seen and recorded the ocean bottom.

The outstanding early work in underwater photography was done by Louis Boutan, operating along the French Riviera during the 1890s. Although not carried out in great depths, his monumental efforts and achievements delineated many of the fundamental problems of undersea photography and earned him the humble respect of many later deep-sea photographers. Not only did he successfully grapple with the problems of seamanship, slow films, and early lenses, but he did such things as night photography using flash powder underwater for illumination. One of his successors, Dimitri Ribikoff, has appropriately christened his Riviera-based photographic workboat *Louis Boutan* in memory of one of the great pioneers of the photographic profession.

In 1935 William Beebe took a picture through the porthole of his bathysphere at a depth

of 900 meters to record his firsthand observations. In 1939 E. Newton Harvey lowered a pressure-cased camera 2500 meters into the water and photographed a pre-placed target. However, he was unable to photograph marine life, which is not surprising in view of the statistical scarcity of larger fish or larger planktonic forms at these depths.

## **The First Deep-Sea Camera Tested Out of Woods Hole**

In 1938–39, Maurice Ewing, Allyn C. Vine, J. L. Worzel, and G. P. Woollard were developing seismic-refraction techniques that they hoped could be used to determine the depth of deep-sea sediments. The desire to see what these ocean-bottom sediments looked like was obvious, as photos might give hints of depositional processes. Somewhat less obvious but equally desirable was that the techniques and ship time used for the seismic work might also be applied to supplementary sea-floor photography. With moral encouragement and financial support from the National Geographic Society, the scientists slightly modified a commercial 16mm camera and designed and built a self-contained, free-floating, multi-shot camera to photograph the bottom down to 5000 meters (Figures 1 and 2).

The camera was placed behind a glass window in an aluminum-tube pressure case, 10.6 centimeters inside diameter. Although consideration was given to using a pressure-resistant window that was curved to reduce stress and distortion, time and cost dictated using a flat window cut from a

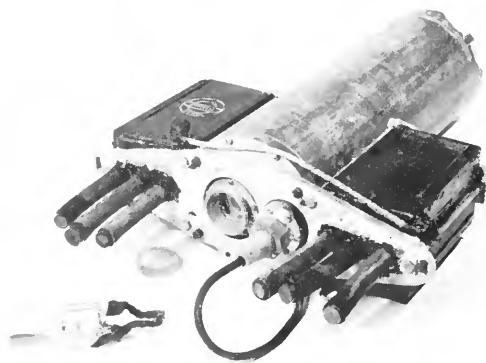

Figure 1. Assembled Camera No. 1, with pressure-compensated lead-acid batteries and 12-volt lamp.



Figure 2. Ewing and Vine holding the pressure case and first deep-sea camera, on board Atlantis, 1940.

small disc of plate window glass 1.2 centimeters thick. The pressure seal was made by grinding the lens onto a flat metal lip around the window in the pressure case and using thick grease as a gasket. Subsequent testing and after-the-fact mechanical considerations showed that making the annular area of contact a small ring somewhat away from the edge of the glass would minimize the effective radius of the port and reduce the chances of the glass port breaking.

Illumination was from a specially built 12-volt, 1000-watt incandescent tungsten-filament lamp made of heavy-walled glass test tubes from the Corning Glass Company. The Nela Park Laboratories of the General Electric Company enthusiastically and generously converted the lamp into a low-voltage, large-current fixture—with the admonition, “It is an odd low-voltage lamp, but it will accept lots of amperes and put out lots of light. Good luck.”

Stroboscopic lights were initially considered because the engineering trade journals were

beginning to publish articles by a young MIT electrical engineer, Harold Edgerton, who was developing and using high-speed electronic flash tubes. Some testing was done with available commercial strobe lights, but the glass containers seemed to break before enough light was emitted. In addition, the extremely high voltages seemed inappropriate for use in a small instrument around saltwater. It was several years later before the close and fruitful cooperation with “Papa Flash” Edgerton began and the strobe light became common in underwater photography.

Both intuition and elementary chemistry suggested that lead-acid batteries would operate satisfactorily when exposed to full sea pressure, if a flexible rubber diaphragm were used to keep the sea water out. After several charge-discharge test cycles of regular motorcycle batteries in laboratory pressure-test facilities, the early assumption was demonstrated to be valid, and the ambient-pressure deep-sea battery eventually became a standard component in the ocean engineers’ “bag of tricks.”

The method of lowering and retrieving the camera was the same as had been developed for some seismic equipment. The camera assembly was operated like a free balloon, without wires or cables. It was taken down by an iron-weight ballast, which was released after a salt block had dissolved, and was floated to the surface by a gasoline-filled float (Figure 3). This technique, which eliminated the

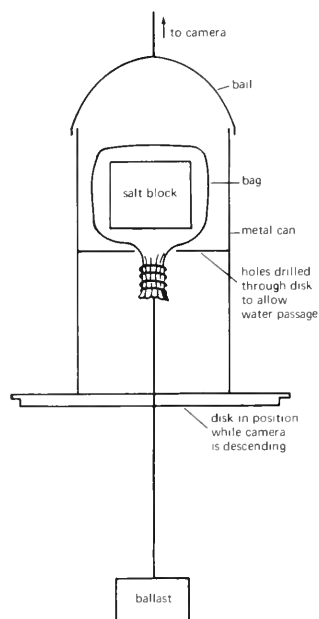

Figure 3. Salt-block ballast release mechanism used for the first camera and for some other cameras and instruments.

need for wires or cables regardless of water depth, was adapted from a *New York Times* account of the Piccards' work on their development of the bathyscaphe, *Trieste*.

The camera, which was periodically triggered by a pre-set electric timer when it reached the bottom, was tested in shallow water in the spring of 1940 and was used on two lowerings from R/V *Atlantis* in 4000 meters northwest of Bermuda in July 1940 (Figure 4). Unfortunately, the



Figure 4. Ewing smiles happily as Camera No. 1 (small flag) comes up without use of wire or cable.

investigators failed to hang a specific object in the field of view to determine whether the camera did take a true picture. The negatives obtained appeared to be technically satisfactory; but if photographically successful, they showed only an unphotogenic sea floor. There seemed to be no way to tell whether the weakness was in the camera or the subject. Certainly the photos were not of the type and quality to interest most readers of *National Geographic*.

Although no proven useful deep-sea pictures were obtained before the camera was lost at sea (after about five lowerings), two things became apparent: First, the depths, pressures, and darkness of the deep ocean were amenable to fairly elementary approaches; second, even though several engineering achievements had apparently been made, scientific or photographic success would require more work.

### The Second Camera

The next phase of underwater photography at Woods Hole was initiated in the spring of 1940 by

the opportunity to work on the *Atlantis* in the Gulf of Maine. Neither schedule nor funds permitted extensive camera design or construction, but earlier tests had confirmed the need for simplicity and then more simplicity.

Since the other scientific work on this cruise required shallow depths (100–600 meters), the gasoline-filled float used on the first camera seemed unnecessary. Thus, for the second camera it was decided neither to lower it on a wire nor to let it float free, but rather to try an intermediate scheme more like handling a lightly tethered balloon as one might a kite on a string. The buoyant camera (Figure 5) would sink by means of iron ballast that would be released by a magnetically operated tripper after the photographs were taken. As the camera floated to the surface, a light restraining line of about an eighty-pound-test fishing cord (“cod line”) was used to draw it back to the ship. This speeded work in the daytime and proved more practical at night and in rough weather. In order to minimize the chance of the line breaking, retrieval was done with only bare hands. It was believed that a two-shot camera would give much more useful and creditable information than a one-shot camera and would be much simpler than a multi-shot camera.

Once the general principle of operation was decided upon, design of the equipment and choice of the camera proceeded rapidly. A large

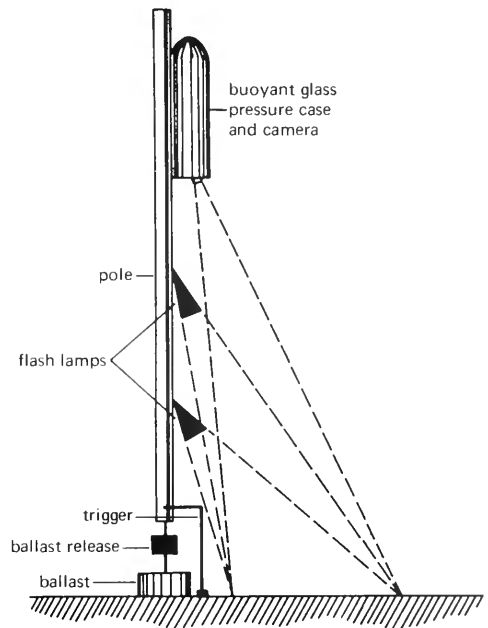

Figure 5. The second camera. A long line was usually attached to permit easy retrieval to the ship, especially at night.

(15 centimeters by 100 centimeters) thick-walled glass-tube pressure case doubled as a float. A visit to local camera stores showed that the new twelve-dollar, 35mm Argus camera met the criteria of price, convertibility, and size. In a few weeks' spare time, the camera frame, time clock, and magnetic releases were finished. The small flash bulbs were unreliable at these pressures due to their odd shape, so they were enclosed in glass carburetor bowls.

This camera proved very successful and was used on several trips in the Gulf of Maine and across the continental shelf. Although far short of good on-land Leica quality, the pictures showed bottom detail, such as sand ripples (Figure 6), and



Figure 6. Ripples on a sandy bottom.

marine life (Figure 7) in a way that brought another level of visual realism into the game of undersea science.

### Wartime Underwater Photography

Underwater photography received considerable impetus and usage during World War II. Only days after the attack on Pearl Harbor, Woods Hole Oceanographic Institution was asked to consider the feasibility of making daily photo mosaics of the channel entrance to Pearl Harbor. A second and later request from the Bureau of Ordnance was to investigate the use of underwater photography in search and survey for enemy mines and for *in situ* monitoring of U.S. experimental mines. A third need was to photograph areas where U.S. Navy destroyers thought they had sunk an enemy



Figure 7. These photographs were taken in the Gulf of Maine (99 m) several seconds apart. The top picture shows a light-colored ribbon (arrow) streaming from the compass. The current vane in the lower left-hand corner indicates a slight current. At the left, just above what appears to be a fisherman's line, is the head of a codfish. Evidently the flash lamp for the top picture startled the fish, and his abrupt departure altered both the direction and magnitude of the immediate current pattern, as indicated by the ribbon and current vane in the bottom photograph.



submarine but where the sonar contact might only have been an old wreck. Each of these investigations presented opportunities and problems usually centering on reliability of equipment and the capacity to analyze and handle the operational situations.

The primary liaison in the Bureau of Ordnance at this time was Captain Charles S. Piggott, who had been a chemist in the geophysical laboratory at Carnegie Institution, as well as a visiting investigator at Woods Hole Oceanographic Institution. Dr. Piggott had earned his professional reputation as a marine geologist and by developing the Piggott deep-sea coring gear. His activities on the *Atlantis* provided some local color because early versions of his gear, which used an explosive charge to drive the core tube into the bottom, occasionally misfired on the deck of the ship. Nevertheless, the gear worked fine and the cause of science was served. It is fitting that years later, Lamont scientists installed cameras on their deep-sea corers to take a picture of the bottom just before the corer struck. Oceanographers were indeed fortunate to have Dr. Piggott as a liaison officer so early in the war.

Large-scale photo reconnaissance of harbor bottoms in murky water was so difficult and different from occasional deep-sea photography that new techniques were required.

A system was developed to tow a closed-circuit television for viewing harbor bottoms and a camera for recording any target viewed (Figure 8). The height of the hydrofoil above the bottom was monitored acoustically and controlled manually with a winch, thus permitting the camera and/or TV to be kept a fixed distance off the bottom. This acoustic technique and variations of it have since become standard in a wide variety of near-bottom measurements. The photo camera used was a 35mm movie camera converted to single-frame operation. After testing, it was decided to monitor with a magnetometer rather than with the TV. Fortunately, the military need for such equipment disappeared just as the initial operational testing phase was completed, and work turned in other directions. Perhaps the greatest technical and conceptual advance in underwater photography made during this project was the use of the strobe light to produce multiple and sharp pictures from a moving camera.

Because the military need for photographing mines did not disappear, techniques and equipment were evolved to do the work with a diver-held camera and with a camera lowered from a ship. It was hoped that the same basic camera could be used in both cases. After several false

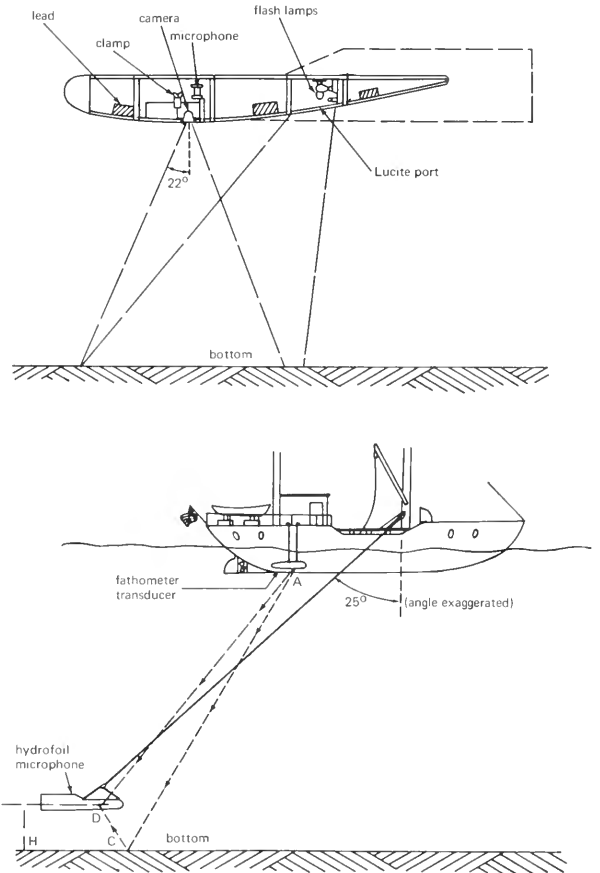

Figure 8. Construction of the hydrofoil (top) and its operation (bottom). One method of determining the height ( $H$ ) of the camera above bottom involved a fathometer transducer on the ship and a microphone on the hydrofoil.  $H$  was one-half the time difference at  $D$  between paths  $ACD$  and  $AD$ . A clinometer was used to monitor the angle of the towing cable.

starts, the small 35mm Robot was chosen as the basic camera and was placed in a small brass case with reliable mechanical lead-through shafts and levers to operate switches and shutters. This hand-held camera (Figure 9) could also be mounted on a vertical pogo-stick frame with flash bulbs and trigger weights to be operated from a ship (Figure 10). Initially test work was done from the Institution's 13-meter boat *Asterias*. Soon their 21-meter ship *Anton Dohrn* became the main photographic work boat and plied the coastal areas—and some of the mine fields—from Portland, Maine, to Norfolk, Virginia.

The three initial investigators—Ewing, Vine, and Worzel—were joined by optical specialists, in particular Drs. E. M. Thorndike and D. E. Kirkpatrick from the physics department of Queens

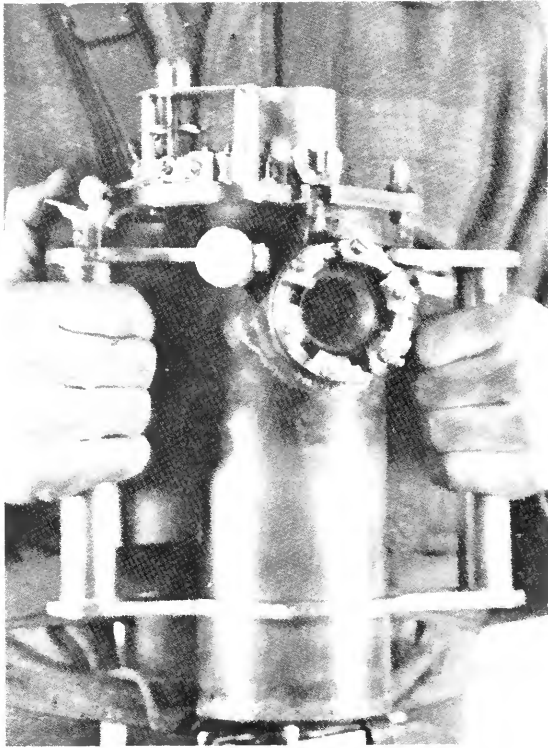

Figure 9. Robot camera for hand-held use by a diver.

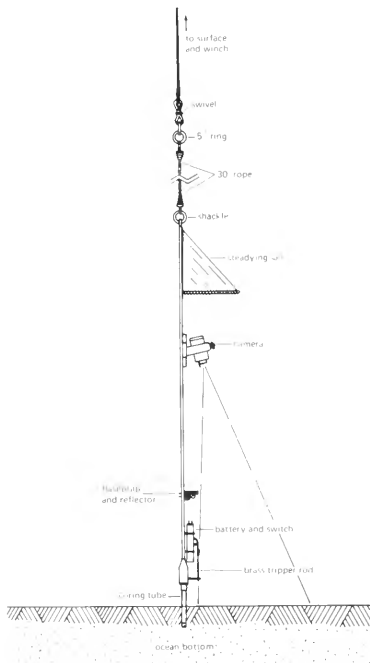

Figure 10. Robot camera rigged in pogo-stick fashion for photographing the ocean bottom or wrecks. Diagram does not include wiring or weights.

College on Long Island. They not only provided much of the optical finesse that was needed in the measuring and best utilization of murky inshore water, but also helped advance the program somewhat from the "rule of thumb" stage to a more quantified approach. Obviously there were many contributions from scientists, crewmen, and Navy personnel that kept nudging the program away from failure and toward success. The Institution's director, Columbus Iselin, provided a few oceanographic facts and many remarkably good guesses as to what visibility, currents, and current reversals might be encountered.

One interesting scheme used in very dirty harbor water and called Project Teepee involved placing a floorless, conical canvas tent on the bottom, with a camera at the apex and suitable light near the bottom. The Teepee was then filled from the top with clear water by a hose from the ship. In this way a bottom picture a meter across could be taken in a harbor where the visibility was normally less than the spread of one hand.

Equipment developed for shallow-water work that supplemented the camera was a modular underwater telescope that permitted direct viewing from the rail of a ship or rowboat down to 12 meters depth. In rough weather it was very easy for the observer to get a black eye as the ship rolled. More serious was the frequency with which the long slender tube became bent, as in Figure 11.



Figure 11. Underwater telescope for shallow-water work.

The utility and simplicity of this telescope gave rise to hopes that something like it would be widely used for sport and science when the war was over. Unfortunately, and rather oddly, this has not happened, although the one still at Woods Hole is being refurbished for a particular use in a local harbor.

During this phase of the work, several special cameras were developed that ended up not being very suitable for the mission, or the wartime needs moved on and the R&D community had to respond to new requirements. It was not unusual to develop, build, test, and deliver a new instrument or major alteration of an existing one during a long weekend or a few weeks. For example, one requirement specified *no* magnetic parts, so a rubber band propulsion system from a large model airplane was incorporated into an otherwise brass, glass, and plastic camera. The fact that we had exceeded the magnetic requirements a hundredfold and had devised a workable but awkward camera was a rather wasteful case of our military-scientific communication being somewhat poorer than our technology.

Perhaps the most interesting military requirement was photographic inspection of enemy submarines reportedly sunken off U.S. coasts by American ships. Clearly, if a destroyer captain thought he had sunk a submarine, it was difficult to prove whether or not he had done so. The confidence of U.S. destroyer men was understandable and well deserved, but so was the need of their superiors to know accurately how effective American efforts were in antisubmarine warfare, and if the U.S. was gaining or losing in this part of the Battle of the Atlantic.

As usual in underwater photography, the operational procedure was more important than the optical quality of the camera. A typical search would start off with a telephone call asking if it were practical and if so, how soon the photographic group and their ship could join a Navy or Coast Guard vessel somewhere along the northeast coast to look for a sunken hull in a stated depth of water. Several times when the two ships got together, the 10-to-15-knot military ship told the 7-knot *Anton Dohrn* to "follow me" and then started to disappear over the horizon. On arrival at the approximated area of the suspected sinking, the ships would search for the wreck with echo-ranging gear. When sonar contact was made, one of the ships would pass over it with the echo sounder to verify the existence of a large object. Then the *Anton Dohrn* would lay out one to three buoys to mark the area, and a rather detailed survey would be made with

the echo sounder to get an idea of the size and complexity of the wreck. Of particular interest was how the wreck lay with respect to the current and prevailing wave pattern. The pogo-stick camera was then lowered in hopes that it would hit the wreck on at least one of its several jumps.

The custom was never to try to take more than a few pictures per lowering because one might entangle and lose the camera with valuable exposures already on the film. Consequently the darkroom gang was always developing a few negatives while the camera crew was trying to take a few more photos. Figures 12-14 demonstrate the range of situations encountered.



Figure 12. The then recently sunken German submarine U-352. Off Morehead City, N.C., in 1942 at 31 m.

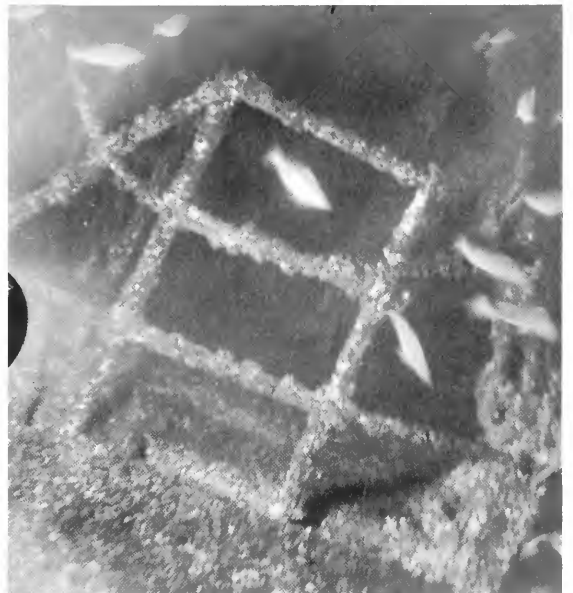

Figure 13. Unidentified wreck that could have come straight from a Hollywood movie. Off Cape Hatteras in 1943 at 42 m.



Figure 14. One of the first photographs of the sunken freighter Coimbra, surveyed off Cape Hatteras in 1943 at 55 m. The photo shows six of the seven letters in her name. To have recorded such unusual identification so quickly defied Murphy's Law and the statistical record compiled in wreck photography. It also helped compensate for the many tedious hours and days when no results were obtained.

Wartime underwater photography not only helped out in one or two tiny segments of the war effort, but also advanced the techniques, achievements, and confidence of scientists in the visual aspects of oceanography. The wartime blitz also brought into oceanography a variety of young men such as G. B. Tirey and J. I. Ewing, who would later become marine specialists.

In 1946 Drs. Ewing and Worzel went to Columbia University where they assembled the group that became Lamont-Doherty Geological Observatory. Underwater photography remained one of their principal research tools. Shortly thereafter, many laboratories had specialized interests in underwater photography, and commercial cameras became widely used to supplement the special ones.

The above account does not include the considerable underwater photography done at or for the Bureau of Ordnance with respect to their version of hand-held underwater diver's cameras for shallow depths. Also, some research in photography of underwater explosives was done at Woods Hole and other laboratories. As usual in describing field work at sea, it is difficult to convey the importance of, and appreciation for, the cooperative crews of the various boats and ships involved.

#### Future Trends

Some of the early efforts in underwater photography were just part of the learning process, and many have been passed by events and technology. However, several trends and objectives seem as

pertinent to the future as they were to the past.

—Deep-sea photography can be simple and economical, as well as informative and fun. Useful cameras can be easily assembled.

—The camera seems to be an underutilized oceanographic tool in the smaller labs and in smaller projects around the world. With boats or yachts of opportunity and with only a few people, valuable spot checks or surveys could be made in interesting areas, on important fishing banks, or across interesting features.

—Positioning is more important than optics.

It is now finally possible, with the mechanical arm of a submersible, to position a camera for *in situ* microphotography of very small marine life or examination of the fine texture of sediments or rock.

—Better photographic libraries with permanent files and improved scientific indexing are needed.

—The old admonition of "Never make a lowering to the bottom without taking a picture" continues to be reasonable advice.

*Allyn C. Vine is a senior scientist in the Department of Geology and Geophysics, Woods Hole Oceanographic Institution.*

Figures 3, 7-10, 12, and 14 from M. Ewing, J. L. Worzel, and A. C. Vine, "Early Development of Ocean-Bottom Photography at Woods Hole Oceanographic Institution and Lamont Geological Laboratory." In *Deep-Sea Photography*, edited by J. B. Hersey. The Johns Hopkins University Press Oceanographic Studies, No. 3. Baltimore: The Johns Hopkins University Press, 1967. Other illustrations from WHOI archives.

#### Suggested Readings

Ewing, M., Vine, A., and Worzel, J. L. 1946. Photography of the ocean bottom. *J. Opt. Soc. Am.* 36:307-21.

Heezen, B. C., and Hollister, C. D. 1971. *The face of the deep*. New York: Oxford University Press.

Hersey, J. B., ed. 1967. *Deep-sea photography*. Baltimore: Johns Hopkins University Press.

Mertens, L. E. 1970. *In-water photography*. Photographic Science and Technology and the Graphic Arts Series. New York: Wiley-Interscience.

# Sea-Floor Photography: Equipment and Techniques

C. L. Buchanan

The first in-water photographs were taken in 1856, but the use of cameras in the deep ocean is a more recent development. Early deep-sea work reflected the modest funding generally available for oceanographic studies. The search for the nuclear-powered submarine *Thresher* in 1963-64 demonstrated the inadequacies of available deep-sea photographic equipment and techniques. As a result, the U.S. Navy and some other government agencies increased R&D funds. Nevertheless, the amounts available remained insignificant when compared, for example, to the cost of photographing the back side of the moon. Recent interest in the economic exploitation of the ocean floor has resulted in increasing non-government support for deep-sea photography. A review of the open literature indicates that current foreign efforts are comparable to the pre-*Thresher* work in the U.S. and are therefore not representative of the present state-of-the-art.

The field of deep-sea photography has been lively for the past twenty years and has been a significant part of oceanography since World War II (see page 6). Many articles and several informative books have been written on the subject, and there are huge collections of excellent sea-floor photographs.

## Applications

In the most general sense, applications of deep-sea photography fall into four classes: search, inspection, survey, and the monitoring of processes and equipment performance. While the boundary lines between these applications are not always clearly defined, the purpose of each is usually clearly understood.

Search implies that a significant object or feature is located within a particular region. The purpose of a search is to locate the object, and the culmination of a successful search is verification that the object found is the one sought. Search

may also include accurate determination of the location so that it is possible to return to the object. The optical or photographic requirement for search is simply that the observer be able to spot a particular object among all other possible objects.

A search in the deep ocean is expensive and is not undertaken unless the object is valuable, such as treasure, or significant, such as a recently lost submarine, ship, or aircraft. If the value is intrinsic, the object may be recovered. Often, however, the value is in the information the object can convey, in which case the next step is detailed observation or inspection.

The photographic equipment and techniques used for inspection are quite different from those used for search. Inspection requires many photographs from different directions. Overlapping photographs are necessary, and stereo photography may be highly desirable, as are high resolution, low distortion, and good perspective. Inspection frequently requires documentation in the form of a mosaic made up of many photographs to show the entire object or feature (see page 18). Mosaics may aid in planning future action, such as salvage, or recovery and reconstruction for archaeological and other purposes, or quantitative measurement of bottom relief and structure for geological research. In other cases, mosaics may serve as records or as public displays (Figure 1).

Search and inspection operations were performed after the research submersible *Alvin* had been lost in 1500 meters of water in late 1968 as the result of a launching accident. In the spring of 1969, wide-angle (110 degrees) cameras from the U.S.N.S. *Mizar* were used to locate and verify the identity of the hulk. After location, normal-angle (30 degrees) cameras were used to inspect the hulk (Figure 2). The information obtained showed that the hulk was intact and proud of the bottom and that the hatch was open—indications that recovery was both desirable and possible. On Labor Day, 1969, the

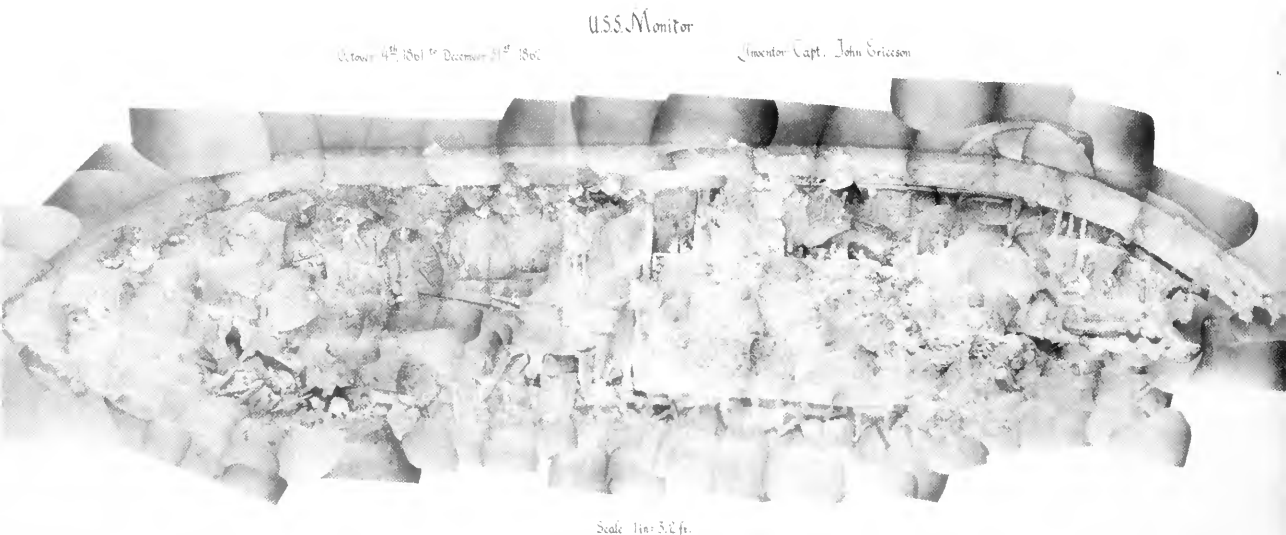

Figure 1. Photo mosaic of the hull of the Civil War ironclad Monitor, which sank off Cape Hatteras, N.C., in 66 m of water in December 1862.

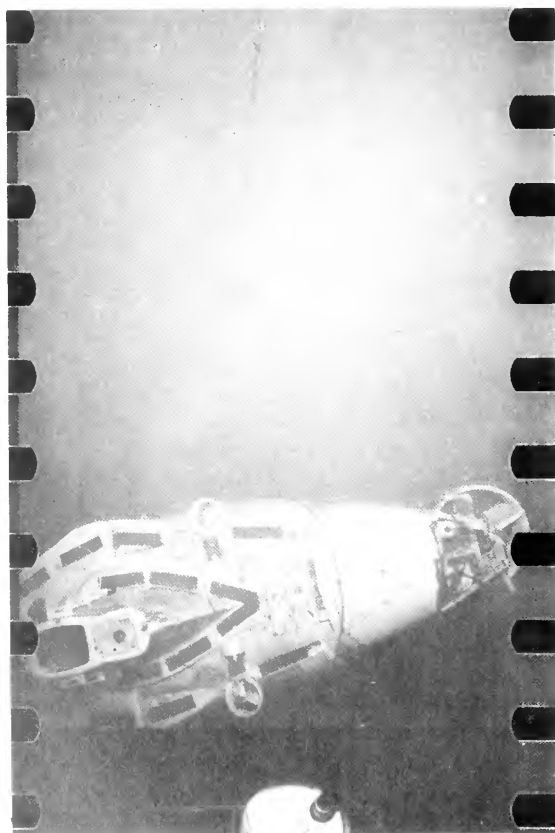

Figure 2. Narrow-angle view of Alvin's hull shows little damage after the submersible plummeted to the ocean floor about 190 km south of Cape Cod.

hull was recovered, and *Alvin* was returned to operating status a few months later.

Survey photography combines elements of search and inspection. A survey is usually aimed not at studying a particular object but rather at determining the number of a certain class of objects in a given area, the distribution of some class of objects in an area, or perhaps the extent of some large feature. The photographic requirements vary, depending on the type of object to be surveyed. Again, stereo photography may well be essential. The dominant feature of surveying is that large quantities of data are sought in order to attain statistical significance or area coverage. For example, it was well known that there were large deposits of manganese nodules off the east coast of Florida, at about 800-900 meters on the Blake Plateau. The data base for this fact consisted of photographs covering only about  $1 \times 10^{-9}$  of the area in random sampling. From a statistical viewpoint, these data were insufficient. In the spring of 1968, a large-scale photographic survey was organized for the purpose of bringing the data base up to a statistically significant level. Approximately 10,000 photographs were collected, covering  $2.5 \times 10^{-4}$  of the area.

Equipment performance or process monitoring involves continuous or time-lapse photography. Examples of this type of operation are illustrated in Figures 3 and 4. Figure 3 shows the end of a rosette water sampler, which holds ten sampling bottles. Theoretically, this device takes a water sample each time it is triggered;

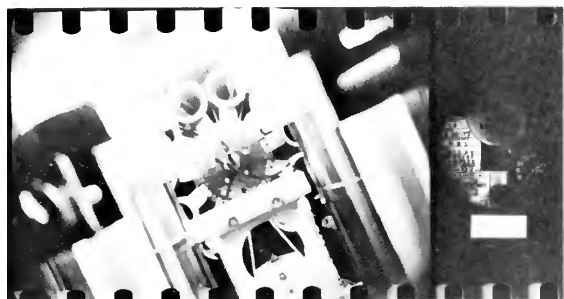

Figure 3. One of a series of photos made to verify that a water sample had been taken and to record the location and depth.

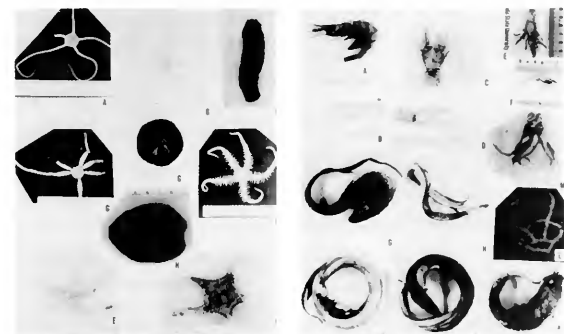

Figure 4. Bottom trawl and data board. Separate photos show a typical catch.

however, it sometimes misfires, making it impossible to determine the location and depth at which the samples were obtained. Periodic photographs, such as the one shown, indicate the time of any misfires and the accurate location and depth at which any samples were obtained. Figure 4 illustrates a deep-sea trawl as it is towed along the ocean floor. Periodic photographs of this type provide information as to when the trawl was on the bottom and also can show indications of malfunctions that might require modification of the equipment.

### Cameras and Lights

The Edgerton camera (EG&G model 204) is probably the most commonly used commercially available deep-sea camera (Figure 5). It was designed to fit a cylindrical pressure-resistant housing with an inside diameter of 114 millimeters.

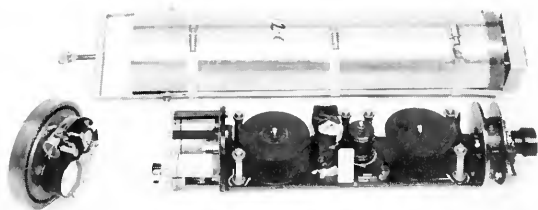

Figure 5. Standard 35mm camera (EG&G model 204), disassembled, showing housing, interior components, and data board.

The lens was specially designed, by Dr. R. E. Hopkins of the University of Rochester, to operate properly with a 25.4-millimeter-thick glass plate between it and the water. The system's focal length in water is 46.6 millimeters. Standard 30-meter rolls of 35mm film are used to produce about 500 photographs with a format of 28 by 40 millimeters. Thin-based film in 46-meter rolls provides about 800 exposures per lowering.

Model 204 consists of two separate cameras, one pointing forward and the other rearward at a data label (showing date, location, run number, etc.) and a collection of instruments, including clock, pressure gauge, and frame counter. As the film is advanced between exposures, gaps are left for the data lens to record its information.

The camera's angular field of view is 46 by 33 degrees. At an extreme operating height of 10 meters above the bottom, the coverage is limited to an area 8.6 by 6 meters, or 52 square meters. The total area covered by a single roll of film is 42,000 square meters, which is only slightly in excess of 0.004 square kilometers. This system is obviously ill-suited for searching large areas.

Increased interest in deep-sea photography after the much publicized search for the *Thresher* led to the development, in 1966, of a wide-angle lens adaptor for the model 204 camera. This modified camera, provided with an increased light level, was able to photograph objects within a circle 30.7 meters in diameter. By means of an additional modification, the film advance was changed to permit 1350 photographs in a circular format 30 millimeters in diameter to be taken with a single roll of film. Although the resolution in the modified system is nowhere near that of the original camera, the increased coverage—0.5 square kilometers on a single roll of film—was considered sufficient to justify its use. At about the same time, a commercial survey camera, the EG&G model 207, was brought out (Figure 6). It accepts either wide-

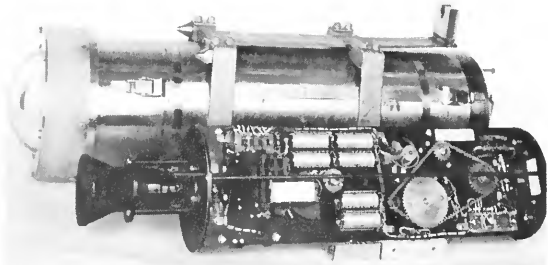

Figure 6. Commercial survey camera and housing (EG&G model 207).

or normal-angle lenses and can take over 4000 photographs per lowering. With the wide-angle optics, it can photograph roughly 1.7 square kilometers per lowering.

The value of wide-angle cameras for search purposes was amply demonstrated in 1968 during the search for the nuclear submarine *Scorpion*, but the necessary use of very short focal length lenses drastically reduced the resolution capabilities of the system (see page 19). An effort was made to overcome this difficulty. During the late 1960s, Ernst Leitz Canada Limited developed a number of water contact lenses. The 67-degree  $f/2.8$  and 90-degree  $f/4$  versions were fitted to 70mm cameras by Astronautical Research and Hydro Products. The ANR model 103 and the Hydro Products PC 700 series will hold 46 meters of thin-based film, and the 90-degree versions will photograph about 0.12 square kilometers per lowering. These cameras provide improved resolution and represent something of a compromise between the requirements for search and those for inspection.

Light sources for deep-sea photography are invariably of the pulsed arc-discharge or strobe type. The energy is stored in electrolytic capacitors and discharged through a xenon flash lamp in a relatively short high-intensity flash. The quartz tube containing the xenon is usually wound into a helix to produce a concentrated source. Reflectors are frequently employed to direct the light in the proper direction.

The level of energy delivered to the lamp ranges from 50 to 500 joules per unit. Lamp efficiency is not very great (about 2%) and, furthermore, the light output is spread across a relatively wide spectrum. Since sea water selectively attenuates the various frequencies, the spectrum width and total energy available are reduced rapidly as the distance to the target increases. For this reason, the use of color photography is limited to relatively short ranges, generally less than four

meters. At extended ranges, all light is lost except that in the blue region.

There is little difference among the various available light sources as illuminators. There is considerable difference in their electrical behaviors, however, and certain types may perform better than others in a particular system. One class of light source, including the EG&G model 208, uses a saturating core inverter to generate the high voltage that charges the capacitors. These lights draw a very large current immediately after discharge. In systems where the camera and light source are powered by the same battery, the high current drain can cause a camera malfunction. The saturating core inverter is very efficient but generates electrical switching transients that can interfere with sonar and other equipment used with the photographic system.

A second type of light source (the ANR model 310 is an example) uses a so-called flyback inverter. The current drain is very low immediately after discharge, builds up slowly to a peak, and then cuts off. These units operate at a single frequency that can be adjusted so as not to interfere with other equipment.

### Techniques

There are three general approaches to photographic geometry. For engineering reasons, it is more or less standard practice to mount the camera and lights relatively close together, but from a photographic standpoint, this arrangement is undesirable. To compromise, the camera and lights are separated as far as is practical with the camera mount being used. There are two departures from this practice, which will be discussed in some detail.

Since sea water scatters light rather uniformly in all directions, except for an increase in the forward direction, a considerable amount is scattered back toward the camera. For this reason it is desirable to choose a geometric relationship that avoids, as much as possible, the illumination of water in the camera's field of view. This is accomplished, in some cases, by placing the light in front of the camera, with a reflector to prevent light from being projected directly back toward the camera. The light may be placed quite close to the area to be photographed. This system has the advantage of requiring the smallest amount of light for the greatest distance. It has two disadvantages: It causes a "hole" in the center of the picture, because the light blocks the field of view and the intense scatter from water close to the light causes overexposure, which blanks out the center of the



scene; and shadows are thrown radially outward from the center and appear abnormal to the viewer.

Another system, which has been developed in the last few years by the Naval Research Laboratory, places the light behind the camera. This system, known as LIBEC, requires a large amount of light. However, the intense light near the source is behind the camera and does not backscatter into the lens. With six 8600-joule lights placed 10 meters behind a camera with a 90-degree lens suspended 25 meters above the bottom, photographs, usable for search purposes, have been obtained of an area more than 50 meters in diameter. At somewhat lesser heights, the system produces excellent quality photographs. There are two features of these photographs that should be noted: Shadows tend to be thrown radially inward, which is only slightly noticeable except where the object, such as a fish, is far above the bottom; and the perspective appears natural because the camera is relatively far from the scene. LIBEC produces the least distortion of any existing system, and with proper control, there is good lighting across the full field of view. Since LIBEC obtains large-area photographs, fewer exposures are required to construct the mosaics needed by geologists, engineers, and others (see page 37).

#### Cables and Fishes

Early deep-sea photographic systems were designed to operate with only a mechanical support cable to the surface, but most modern systems use a combined electrical and mechanical cable. The

electrical cable supplies power and serves as a telemetry link capable of turning the system on and off, flashing the strobe lights, advancing the film, etc. The cable for a simple lightweight system may be as small as 5.55 millimeters in diameter. Several laboratories use a relatively standard cable 17.27 millimeters in diameter, consisting of a coaxial electrical cable armored with steel and having a breaking strength of over 15,000 kilograms. Such a cable, which may be more than 6 kilometers long, requires a large, specially designed winch.

The vehicle on which the camera and lights are mounted is usually referred to as a "fish" (Figure 7). There is no standard design, but the vehicle has a framework on which the various instruments are mounted. Sometimes an attempt is made to enclose the system in a fairing, but since the towing speed is one knot or less (because of the cable drag), the fairing is ineffective and can be dispensed with.

Towing such a system is an art. At a speed of one knot, the fish will trail behind the ship at a distance equal to about one-half its depth in the water. This fact must be kept in mind when maneuvering. If the ship is heaving, the motion is instantly transmitted down the cable, causing the fish also to move up and down. When the system is close to the bottom, this motion can cause significant changes in photographic scale from one exposure to the next.

The exact location of the fish can be determined by means of an acoustic tracking system, of which two types—short and long baseline—are in



*Figure 7. Fish used for underwater photography by the Naval Research Laboratory.*

general use. The short baseline system, illustrated in Figure 8, involves an array of three acoustic transducers (hydrophones) on the ship working in conjunction with a transponder (responder) on the fish (towed instrument vehicle). The long baseline system uses three transponders mounted near the sea floor, which are keyed by an interrogation system on the fish. Either type can measure the fish's position with sufficient accuracy to permit a relatively well ordered search pattern to be followed.

### Utilizing the Photographs

Unfortunately the process of extracting information from photographic images has not been well developed. As a result there are large quantities

of deep-sea photographs (at least one million) that have been viewed with only one objective in mind, usually to find a particular lost object. Great quantities of other valuable data remain essentially unseen. It appears to be difficult, if not impossible, to develop procedures for extracting and analyzing all the available information. Studies of large photographic collections have scarcely begun to measure their value.

*C. L. Buchanan has recently retired as associate superintendent of the Ocean Technology Division, Naval Research Laboratory, Washington, D.C.*

*After submitting the first draft of this article, the author was in an accident. R. B. Patterson of the Naval Research Laboratory therefore undertook minor revisions and proofreading, and he assumes responsibility for any errors.*



Figure 8. Short baseline tracking system for determining the position of the fish.

# Future Developments in Deep-Sea Imaging

Robert B. Patterson

In discussing the optical imaging and acoustic imaging techniques that have predominated in the past and will continue to do so in the immediate future, it is useful to first consider the factors that limit the performance of in-water camera systems. The range of early deep-sea cameras was limited most severely by the low illumination level of the available light sources. With the development of more powerful lights and more sensitive films, backscatter became the limiting factor, reducing contrast in the same way that fog reacts with automobile headlights to reduce visibility. Several techniques have been developed for reducing backscatter, and others are being evolved. However, even sophisticated systems of the future, sensitive enough so as not to be illumination-limited, will still be range-limited by the forward-scattering characteristics of water, which degrade the information content of the light traveling from the object to the lens. This is an absolute range limit that cannot be overcome short of draining the oceans.

Early in-water cameras used conventional lenses mounted behind flat lens ports. This technique introduces astigmatism, chromatic aberration, and other difficulties. Many satisfactory photographs are taken using this technique, but they lack the sharpness and contrast obtainable with the same lenses out of water. While the water turbidity contributes to this degradation, the uncorrected lens aberrations are also a major factor. There have been numerous attempts to overcome these difficulties, culminating in the design of special lenses for use in water. The need for small camera housings and the desire for an increased number of photographs led to the use of small film formats, which further limits resolution capabilities. Even with perfect lenses and grainless film, the resolution of an in-water camera would be limited by the

forward-scattering characteristics of water. This makes it desirable to know the scattering characteristics of the medium so that one can determine how close a given system approaches this ultimate limit.

It is often more important to increase area coverage than it is to extend the range capability of an in-water camera system. The ocean floor is large, and with a narrow-angle camera it takes many exposures to cover even a small area. For example, the mosaic in Figure 1 uses 30 photographs to cover an area of about 450 square meters. The mosaic of the sunken submarine *Thresher*, of which this is a small portion, was probably the first attempt (it was completed in 1965) to make a photo mosaic of so large an area of the ocean floor. The large number of photographs used was necessitated by the narrow field of view and the short-range capability of the then-existing deep-sea photographic equipment. A wide-angle lens system, developed in 1966, was used to produce the increased coverage shown in Figure 2. This mosaic required 40 exposures to cover an area of approximately 3000 square meters. The modern LIBEC (Light BEhind Camera) system, designed by the Naval Research Laboratory to obtain the maximum practical area coverage by use of optimum lighting geometry, produced the mosaic shown on page 37. In this case, 7 photographs were used to cover an area of about 2500 square meters. The photographs used for this mosaic were taken with a 70mm camera, while Figures 1 and 2 were obtained using 35mm cameras. These three mosaics document a significant increase in area coverage, but one needs only to compare the area of the ocean floor to the coverage of a single LIBEC photograph to see the value of increasing coverage capabilities still further.



Figure 1. The sail of the U.S.S. Thresher (SSN-593), lost in 1963. This is a portion of a mosaic containing more than 900 photographs, which shows all major portions of the hulk and the surrounding ocean floor off the entrance to the Gulf of Maine at 2500 m.

A study of the three mosaics reveals that the increased coverage resulted in a loss of resolution. This loss of detail is shown even more clearly in the next two examples. Figure 3, which was taken at close range with a narrow-angle 35mm camera, contains considerable detail, and it could have contained much more if a better lens and/or a larger film format had been used. Even without these improvements, it contains much more detail than Figure 4, which was taken from a range of about 9 meters using an extreme wide-angle lens on a 35mm camera. While this photograph was useful from a search point of view, its lack of detail reduced its usefulness for inspection purposes. These examples clearly demonstrate the need for improving the resolution capabilities of future deep-sea cameras.

## Modulation Transfer Function Measurements

The Modulation Transfer Function (MTF) is a recently developed concept that has proved useful in the solution of a number of photographic problems. To obtain the MTF, one images a test pattern that produces an illuminance varying sinusoidally in space. This pattern also contains different wave lengths and has a known amplitude. A plot of the input/output amplitude ratio as a function of wave length is the MTF. The transfer functions of a number of optical components can be multiplied together to obtain the MTF of the combination. For example, one can multiply the MTF of a lens by that of a film to obtain the transfer function of the two used in a camera. This combined MTF could then be multiplied by that of the water path to obtain the transfer function of the camera in water. Knowing the MTF of a water path as a function of its length will make it possible to optimize the performance of existing camera systems, to determine the maximum gains possible with improved system design, and to determine how closely any system, existing or contemplated, approaches this ultimate limit.

Intuitively, one might think that the MTF of a water path would be an exponential function of its length, but some investigators feel that this is not so. Measurements of the MTF for water paths of various lengths are currently underway in an attempt to resolve this question. These measurements will be made first in the laboratory, starting in clean water, then in water of controlled turbidity. It is very possible that water near the deep-ocean floor is cleaner than any obtainable in the laboratory. The laboratory measurements will be followed by a series of *in situ* measurements designed to validate the laboratory results. Ultimately, it must be

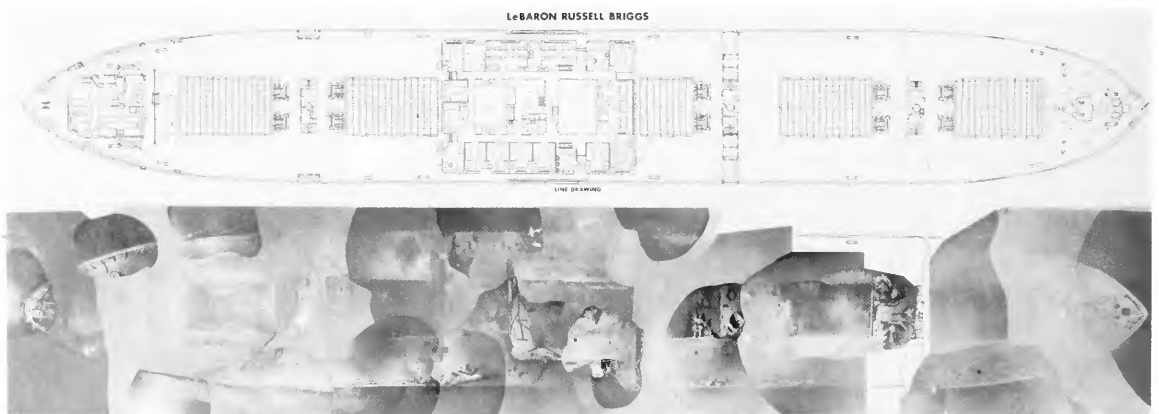

Figure 2. The U.S.S. LeBaron Russell Briggs on the ocean floor, at a depth of 4900 m. This Liberty ship was sunk in 1970 to dispose of 68 tons of chemical warfare agents.

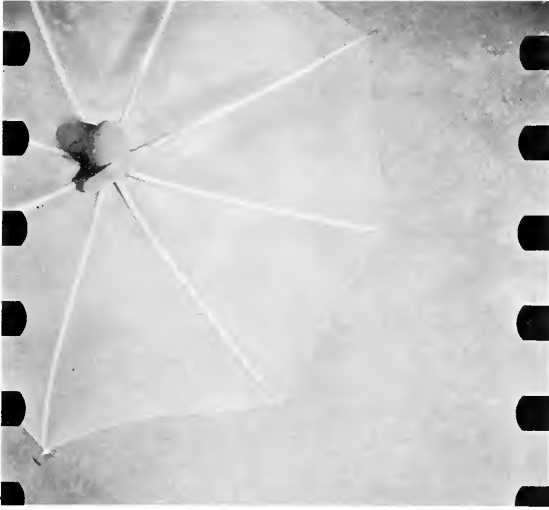

Figure 3. A cirrate octopus photographed in the Virgin Island Basin. The detailed marks and texture, particularly in the interbrachial web, demonstrate the resolution obtainable at short ranges with narrow-angle cameras.



Figure 4. The bow of the U.S.S. Scorpion (SSN-589), lost in the mid-Atlantic in 1968. This photograph demonstrates the loss of resolution resulting from the use of increased ranges and extreme wide-angle lenses on small-format cameras.

determined whether the MTF of a large body of water can be characterized on the basis of a relatively few measurements. If this is not possible, it may be necessary to obtain measurements at each photographic site in order to optimize the equipment and techniques for the job at hand.

### Increased Area Coverage

The bottom area photographed by an in-water camera can be increased by increasing either the field of view or the range between camera and bottom. For optimum results, these techniques can be used together.

For a camera system operating at the limit of its range capability, the width of the area photographed is proportional to the sine of the angle whose tangent is the half-width of the film format divided by the distance between the lens and film plane. A lens with an angle of 45 degrees will cover 70 percent of the maximum possible width. With an angle of 60 degrees, the coverage is increased to 87 percent, and beyond that the additional coverage is probably not worth the resulting increased lens complexity and decreased image quality. Extreme wide-angle lenses also give poor perspective, which makes it difficult to analyze photographs and to use them in mosaics. High-quality lenses with half-angles between 45 and 60 degrees are currently available for in-water cameras using 35mm, 70mm, and 105mm film.

As previously mentioned, today's deep-sea camera systems are generally range-limited by backscatter. A number of possible methods for reducing backscatter are illustrated in Figure 5. In

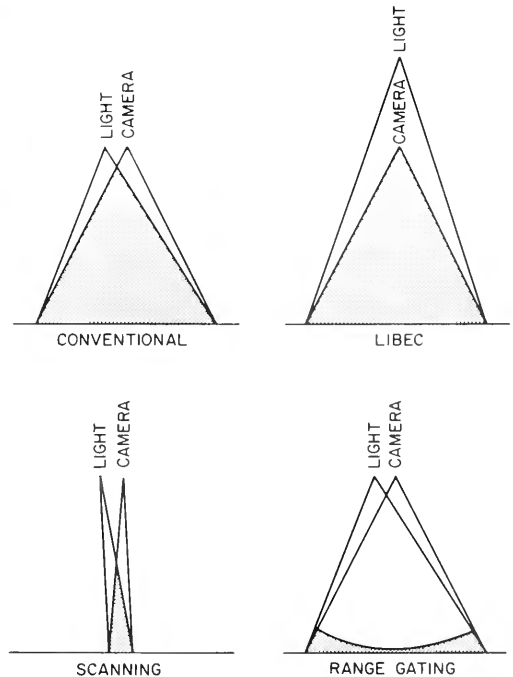

Figure 5. An illustration of the backscattering volumes of conventional and improved lighting systems designed to reduce backscatter.

the conventional deep-sea system, the light is placed a short distance to the side of the camera, which receives backscatter from the common volume bounded by the camera's field of view and the light's field of illumination. A cross section of this volume is shown as the shaded area in the figure. Since the light intensity at points within this volume decreases by the inverse square of their distance from the source, and even faster if attenuation losses are significant, portions of the volume closest to the light contribute most of the backscatter.

Backscatter can be reduced by increasing the separation between light source and camera. This technique has probably been taken to its practical limit by LIBEC, which has photographed high-contrast targets at ranges greater than 36 meters and a ship hull on the sea floor 24 meters below the camera. As can be seen in Figure 5, the backscattering volume of the LIBEC system is increased slightly over that of the conventional system shown, but this volume is farther from the light source, so its illumination level and the resulting backscatter are reduced. Mounting the light the same distance to the side of the camera will produce a slightly better image-to-backscatter ratio over a large portion of the field of view, but a 10-meter lateral separation is not practical with most contemporary deep-sea systems.

In the scanning technique, the fields of view and illumination are made quite small, thus reducing the backscatter volume. In practice the two fields would be much smaller than those shown in the figure, which are exaggerated to show the backscatter volume. This reduction increases the separation between light and volume, thus reducing the illumination level within the volume and the resulting backscatter. The two fields are scanned synchronously to provide practical area coverage. The major difficulty with this system is assuring that the volume bounded by the two fields also intersects the object being photographed. A number of scanning systems have been or are in the process of being produced, and there certainly will be considerable work on this technique in the future. Until more information is available on the MTF and other optical characteristics of ocean water, it is not possible to predict the range limits of scanning systems, but they are certainly significantly greater than the usable ranges achieved with LIBEC.

Another technique for reducing backscatter is range-gating. This method requires a light source able to produce a light pulse with a very rapid termination, and a camera shutter that opens very rapidly. The light is transmitted and the shutter is

opened after most of the backscatter has passed the lens. This greatly reduces the backscatter volume, as is shown in Figure 5. This volume is quite far from the light source, further reducing the backscatter. Suitable lights and shutters have not been available until recently. Newly developed gated image intensifiers can provide the required shutter speed while reducing the illumination requirements. Dye lasers have been developed that provide suitable pulses at a wave length with minimal attenuation in sea water. The Naval Research Laboratory is developing a range-gated system designed to operate at a height of 70 meters with a 90-degree field of view. These parameters correspond to a coverage of 15,000 square meters per photograph, which is greater than five times the area of the LIBEC mosaic on page 37.

A combination of the scanning and range-gating techniques could provide even greater improvements. Such systems may be developed, but this work will probably await the optimization of equipment using the two techniques separately.

### Acoustic Imaging

For surveying ocean-floor features or searching for large objects on the sea bottom, some resolution can be sacrificed to obtain greater range. Acoustic systems have been used in this way for many years. A depth-recorder trace is similar to a television scan line, so a systematic bathymetric survey is equivalent to a single video frame. Most depth recorders have a wide beam width, so the resolution is poor; but a number of narrow-beam systems have been developed to improve resolution. Both Woods Hole and Scripps oceanographic institutions have obtained improved resolution by using two depth recorders mounted on a vehicle operated close to the bottom. The downward-looking instrument resolves small changes in topography, while the upward-looking instrument references the vehicle depth.

Side-looking sonar systems have been developed to provide increased coverage width. These systems use a transducer with a narrow beam width in the horizontal plane, mounted with the beam perpendicular to the direction of vehicle motion. The time from a pulse transmission to an echo return is a measure of the distance between transducer and reflecting object. The transducer is pulsed periodically, and the returns are recorded to provide lines of a television-like representation of the ocean floor. The vehicle motion provides the other dimension. Systems of this type vary from a low-frequency ship-mounted device developed by the British, which has inspected major geological

features of the deep-ocean floor at ranges in excess of 20 kilometers, to small high-frequency units towed by or mounted on submersibles for use near the bottom that provide improved resolution at ranges measured in hundreds of meters. An example of results obtained with this latter type of equipment is shown in Figure 6, which records sonar returns from the U.S.S. *Briggs* (the ship shown in Figure 2).

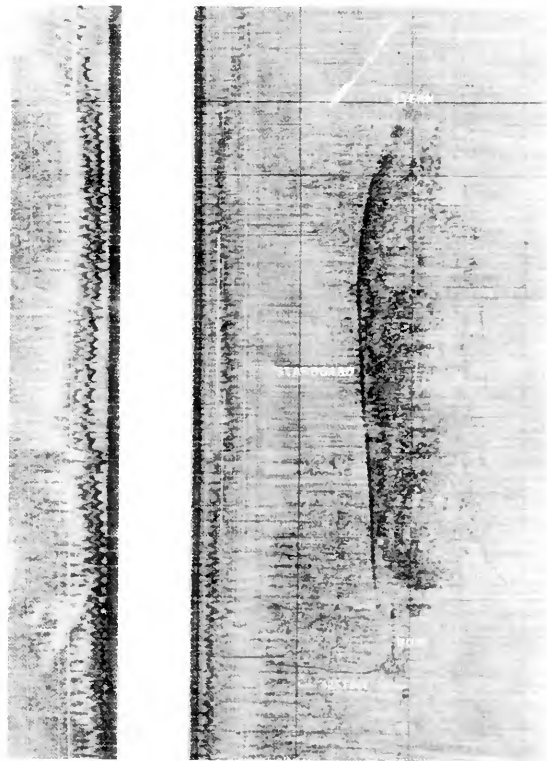

Figure 6. A side-looking sonar record showing acoustic returns from the U.S.S. *Briggs* (shown in Figure 2). The sonar system passed down the starboard side of the hulk at a distance of about 60 m.

The depth-recorder and side-looking systems currently used are relatively crude devices with resolution which does not approach that theoretically possible with the wave length used. A number of more sophisticated techniques are being investigated in an attempt to fill the gap between the low-resolution long-range acoustic and short-range high-resolution optical systems now used. Acoustic lenses and holography are similar to their optical counterparts and somewhat difficult to explain in an article of this type. In synthetic aperture sonar, one transmits a number of pulses from a side-looking sonar system and uses a computer to process the returns in such a way as to generate

an aperture with an effective length equal to the distance traveled while the pulses were being transmitted. This large aperture narrows the beam width to improve the resolution of the system. It is difficult to make specific predictions about the improvements that will be made using these and other new techniques, but this is an area in which major breakthroughs will be achieved in the next five to ten years.

### Improved Resolution

As mentioned previously, high-quality lenses designed specifically for use in water are already available, and no major gains in resolving power will result from lens improvement. However, there are problems with the available lenses that require further study. In deep water, the lens port is subjected to high hydrostatic pressures that induce physical distortions much larger than the fractional wave-length tolerances of good lenses. These distortions cause defocusing and other aberrations. The defocusing can be cured by simple adjustments, but eliminating some of the other effects requires redesign of the lenses. In either case, a better understanding of these mechanical distortions is needed, and studies of this problem are planned.

One technique for reducing the detrimental effects of lens port distortion is shown in Figure 7. The lens is designed so that the volume (15) between the lens port (14) and the next lens element (13) is flooded with water. The volume is vented (16) to a pressure-release device (17) so the lens port distortion does not induce any strain in the next lens element. The refraction at a glass-water interface is much smaller than that at a glass-air surface, and the detrimental effects of the lens port distortion are thus significantly reduced. A lens of this type has been designed, fabricated, and tested.

Mounting a camera lens with its entrance pupil at the center of curvature of a concentric spherical shell lens port causes no image distortion, though it does introduce significant amounts of chromatic aberration and image field curvature. A long water path acts as a blue filter, so long-range photographs are not affected by the chromatic aberration. This is true for either black-and-white or color film, though color film has little use in long-range in-water photography. If one likes blue pictures, it is easier to look at black-and-white photographs through a blue filter. The adverse effects of the field curvature could be reduced by using a fiber optic plate as a field flattener. The film is held against the plane rear surface of the plate while the image is focused onto the front

[54] **LENS PROTECTIVE SYSTEM FOR DEEP SEA CAMERA**  
[75] Inventor: **Chester L. Buchanan, Camp Springs, Md**  
[73] Assignee: **The United States of America as represented by the Secretary of the Navy, Washington, D.C.**  
[22] Filed: **July 17, 1972**  
[21] Appl No. **272,244**  
[52] U.S. Cl. .... **95/11 UW**  
[51] Int. Cl. .... **G03b 17/08**  
[58] Field of Search ..... **95/11 UW**

[56] **References Cited**  
**UNITED STATES PATENTS**  
2,256,133 9/1941 Barnes ..... 95/11  
**FOREIGN PATENTS OR APPLICATIONS**  
969,065 4/1958 Germany ..... 95/11  
**Primary Examiner—John M. Horan**  
**Attorney—R. S. Sciascia et al.**

[57] **ABSTRACT**  
A lens arrangement for a camera useful in deep sea photography. An optical coupling fluid is provided between a protective window and the lens which absorbs the pressure to protect the lens thereby permitting the use of thinner lens materials

**5 Claims, 1 Drawing Figure**

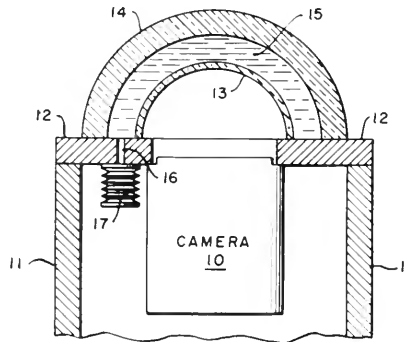

*Figure 7. The front page of a patent for a technique that reduces the effects of pressure-induced distortion of deep-sea camera lens ports.*

surface, which is ground to the shape of the curved image field. There are plans to test this technique, which could reduce the costs of developing in-water lenses.

At very long ranges, the decreased MTF of the water path may so dominate a system as to become the predominant factor in determining resolution. However, at shorter ranges, the MTF of the lens and film will also affect the system performance, and, therefore, developments aimed at improving these components are in order. There are two means of improving the resolution capability of the film. One can use a better film, which generally means a less-sensitive finer-grained emulsion. There is occasionally discussion of films designed specifically for in-water applications, but the demand has not been sufficient to make special film types economically practical. The second means of improving the resolution capability of film is the use of a longer focal-length lens. This will decrease the field of view, unless the image format is increased by the same factor. Early deep-sea cameras used 35mm film, but it was realized that larger formats would improve image quality, and 70mm deep-sea cameras have been available for

some time. A deep-sea camera using 127mm film is currently being developed, and field tests are planned for next fall. It is doubtful whether larger film sizes will be used to any great extent in the deep ocean, though a few years back, Eastman Kodak used 229mm film for taking some shallow-water photographs.

All that has been said so far deals with improving the equipment and techniques used to take deep-sea photographs. It is also possible to improve the image quality of photographs already at hand. We have all seen numerous photographs, produced by the National Aeronautics and Space Administration, which have been improved by post-exposure image enhancement techniques. One such process involves scanning and reducing the image to digital information. This information is fed into a digital computer, where filtering and smoothing techniques are used to extract all available information and remove unwanted signals. The result is fed out like a television signal and re-recorded on film to produce an improved photograph. It is possible to compensate for poor focus, object or camera motion, and other image problems. The same techniques can often be



applied with an optical computer, which offers a significant savings in time and money. Little work of this kind has been done with in-water imagery, but these techniques will be used frequently in the future.

### Conclusions

We are living in a period of very rapid technological growth, so the future undoubtedly holds many surprises. However, most future technology will be based on principles and techniques now known, which makes it possible to foresee some developments. This discussion has presented a glimpse at some future progress in the field of deep-sea imaging. Measurements of water's optical characteristics, such as the Modulation Transfer Function, will provide a better understanding of the processes that limit the performance of existing in-water cameras. This understanding will make it possible to develop sophisticated techniques for improving the range, coverage, and resolution of in-water photographic systems. More utilization will be made of the post-development image enhancement methods developed in the space program. The use of more sophisticated techniques will also improve the resolution capabilities of acoustic imaging devices while retaining the range advantages of acoustic over optical radiation in water.

Progress in deep-sea imaging has been, and will continue to be, retarded by limited demand. The cost of in-water cameras and lenses is increased and the quality of their engineering is decreased by the need to spread engineering costs over small production runs. Special films and other products designed for improving the quality of in-water imagery are often economically impractical. It is possible that increased exploitation of the ocean floor will increase demand to the point that more funds are available for development programs. If this does not occur, the field will continue to progress at its present rate, using limited funding from military and scientific programs and appropriate spin-off from higher-priority projects.

*Robert B. Patterson is a research physicist at the Naval Research Laboratory, Washington, D.C.*

# Biological Applications of Underwater Photography



*Many large grenadier on a manganese nodule bottom in the midwestern Pacific, 5850 m. Can diameter is 32 cm.*

John D. Isaacs and Richard A. Schwartzlose

Before the development of deep-sea cameras, trawls or traps or set lines with baited hooks were the main methods for sampling the abyssal zones. In recent years cameras have been lowered from ships by wires or installed on deep-diving submersibles to record larger fish. The difficulty with these systems, however, is that the cameras cannot be maintained in one location for long periods of time. In addition, they have not been suitable for the effective use of bait to attract fish so that clear observations can be made of the variety of active creatures in the vicinity.

These problems have been approached by the use of the autonomous, or free-vehicle, camera system developed at Scripps Institution of Oceanography by Meredith Sessions, Richard Shutts, and the authors. With this technique it is possible to photograph and observe the nature and behavior of active creatures of the deep-sea floor when they are attracted by food.

The camera system is deployed freely from the ship and sinks to the bottom. Both the still (35mm) and movie (16mm "cine") cameras are programmed to obtain pictures at set intervals, using strobe lights or intermittent floodlights, for periods as long as two days, during which are photographed the creatures attracted to the bait held in view of the cameras. The system remains on the sea floor until the ballast is released at a pre-set time and the system returns to the ocean surface, where it is located and recovered by the ship using radar, radio direction, or visual means. The free-vehicle method of deployment and recovery allows the scientists aboard the vessel to release a number of the cameras over a large area while conducting other types of oceanographic research, retrieving the cameras on their return at a time convenient to the ship's schedule.

We have photographed abyssal creatures in color and black-and-white, with still and cine cameras, in stereo and close-ups, at nearly all depths, and in locations throughout the world oceans—the Pacific, the western Indian Ocean, the eastern Mediterranean, the Antarctic, and the South Atlantic. The cameras have explored continental shelves, abyssal plains, and ocean trenches; they have recorded a wide range of faunal species, in both depth and geographic location.

Of the locations our cameras have explored, one of the richest has been the San Diego Trough off Southern California. There, in 1400-meter depths we have photographed multitudes of grenadier (*Coryphaenoides* sp.) and sablefish (*Anoplopoma*

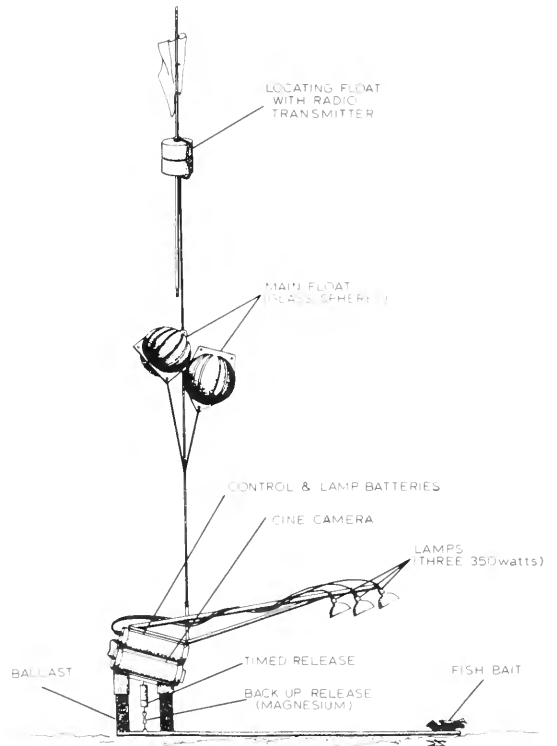

*Free-vehicle cine system.*



*Hagfish attacking bait. Crabs are also in view. Off Cabo de San Lucas, Baja California, 1664 m.*



*Large shark, grenadier, eels, hagfish, and shrimp off Oahu, Hawaiian Islands, 1900 m. Can diameter is 32 cm.*



*Sablefish (light-colored, larger fish) in and around bait can. Off San Diego, California, 1218 m.*

*fimbria*), myriads of hagfish (*Myxine* sp.), large beds of brittle stars, and a number of very large sleeper sharks (*Somniosus* sp.).

We had known that hagfish, primitive jawless chordates, were plentiful in the San Diego Trough because they had been caught in 19-liter can-traps in such density it would seem that not another could force its way into the trap. Our still photographs show the hagfish dominating the bait, while the true fish lurk about the outer edges of the pictures. Our first cine pictures show much the same as the stills: the hagfish dominate the bait. However, when we obtained close-up cine photographs, we found that these hagfish had enveloped the bait with a cocoon of slime, and any fish that entered into the mass emerged frantically attempting to rid its mouth and gills of the ropy material.

In this same general location, but where the hagfish are not plentiful, grenadier have been photographed violently shaking and jerking at the bait, ripping off large pieces. Sablefish have been seen engaged in rapid spinning motions to twist off pieces of flesh. These types of feeding would not have been predicted from their mouth structure, nor from the still pictures. These fish dart toward and away from the bait, not colliding but often stirring up large clouds of sediment. At times all the fish suddenly scatter and a large shark appears, sometimes covering the entire field of view; only various parts can be glimpsed as it glides by the camera. It is impossible to determine the length of these sharks since only a portion is visible in any one photograph, but one of them has a head at least one meter high.

In the western Indian Ocean, sharks are the dominant fish at depths from 200 to 600 meters. They have been photographed in all sizes and attacking positions trying to seize the bait. The still photos and cine pictures indicate these sharks have difficulty finding the bait, particularly when it is cocked above a rough bottom. They will often bite at rocks, nudge the bottom, and make continuous sorties around the bait in slow, ritualistic and geometric search patterns; yet they seem quite incapable of discovering it. Hagfish also appear unable to locate the bait when it is somewhat off the bottom. It is these sorts of observations that are valuable in guiding fishery methods.

The very deep near-bottom fish photographed between 3500 and 6000 meters have all been large, mature fish and consist primarily of grenadiers, some eelpouts, and a very few brotulids. The eelpouts and brotulids are not very active swimmers. The eelpouts slowly swim to the bait

The Magazine of Sea Science  
**Oceanus**

## Why not subscribe to Oceanus . . .

I wish to subscribe to your quarterly for one year.

- I enclose my check for \$8.00 (\$10.00 if you live outside the U.S.) payable to Woods Hole Oceanographic Institution.
- Please bill me.

\_\_\_\_\_  
Name

\_\_\_\_\_  
Address

\_\_\_\_\_  
City State Zip

## . . . or give Oceanus to one friend?

Please enter gift subscriptions in my name for

\_\_\_\_\_  
Name

\_\_\_\_\_  
Address

\_\_\_\_\_  
City State Zip

Insert order form and check—if you're mailing one—in attached envelope and mail. Don't forget change of address on reverse side if you're moving.

. . . OR



ial Indian Ocean, 265 m.

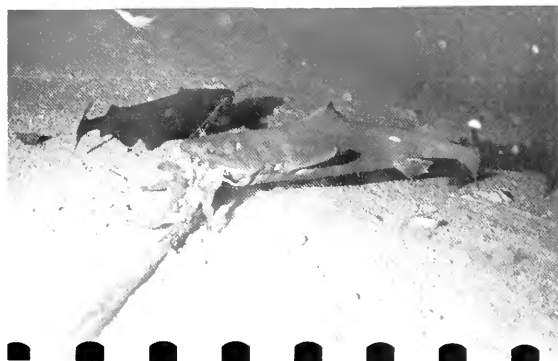

Sharks, shrimp, and flatfish in western equatorial Indian Ocean, 825 m.



Six-gill shark at bait. Note parasites on shark. Bait is about 65 cm long. Western equatorial Indian Ocean, 640 m.



*Large shark, grenadier, eels, hagfish, and shrimp off Oahu Hawaiian Islands, 1900 m. Can diameter is 32 cm.*



*Sablefish (light-colored, larger fish) in and around bait can. Off San Diego, California, 1218 m.*

**Business Reply Mail**  
 No postage necessary if mailed in the United States

# Oceanus

The Magazine of Sea Science

Subscription Office  
 2401 Revere Beach Parkway  
 Everett, Mass. 02189

FIRST CLASS  
 PERMIT NO. 23748  
 BOSTON, MASS.

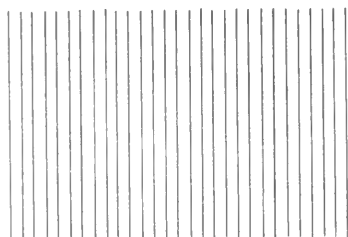

have difficulty finding the bait, particularly when it is cocked above a rough bottom. They will often bite at rocks, nudge the bottom, and make continuous sorties around the bait in slow, ritualistic and geometric search patterns; yet they seem quite incapable of discovering it. Hagfish also appear unable to locate the bait when it is somewhat off the bottom. It is these sorts of observations that are valuable in guiding fishery methods.

The very deep near-bottom fish photographed between 3500 and 6000 meters have all been large, mature fish and consist primarily of grenadiers, some eelpouts, and a very few brotulids. The eelpouts and brotulids are not very active swimmers. The eelpouts slowly swim to the bait

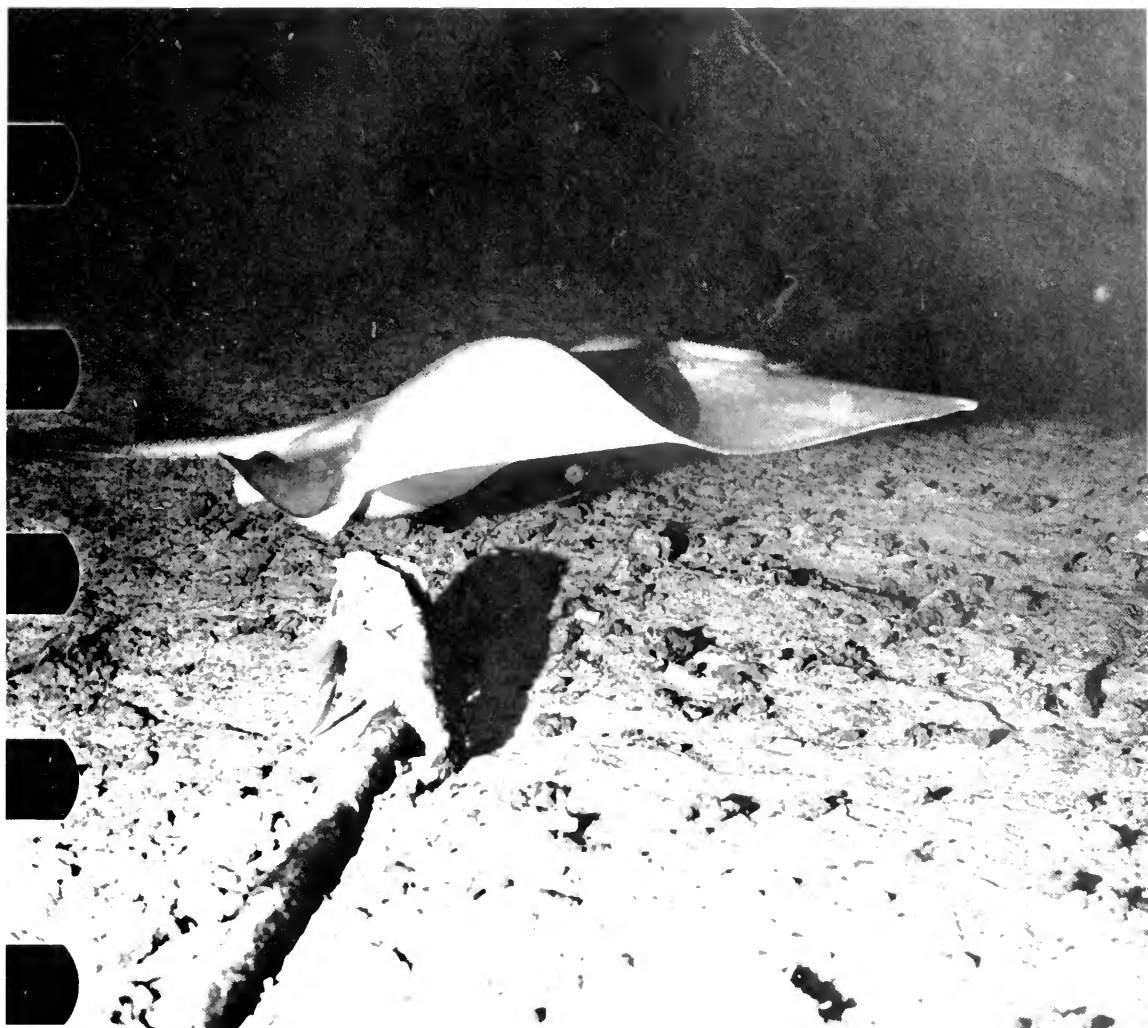

*Ray off Wizard Island of the Cosmoledo Group, western equatorial Indian Ocean, 265 m.*



*Sharks, shrimp, and flatfish in western equatorial Indian Ocean, 825 m.*



*Six-gill shark at bait. Note parasites on shark. Bait is about 6.5 cm long. Western equatorial Indian Ocean, 640 m.*



*Octopus and grenadier off central Baja California, 3584 m.*



*Pacific jack mackerel photographed at night with the "drop camera" off Santa Cruz Island, California, 5 m. Density of fish is 31 per cubic meter. (John Graves, NMFS)*





*Multitude of amphipods and several shrimp devouring bait. Chile Trench, 7000 m.*



*Grenadier, celpouts, hagfish, quillworms, starfish, brittle stars, and crabs. Off northern Baja California, 2008 m.*

and then remain almost motionless for 15–90 minutes, apparently nibbling the bait; the brotulids drift or hang motionless at the edges of the pictures, seeming never to approach the bait. In contrast, the grenadiers dart toward and away from the bait, biting off chunks of flesh and stirring up the bottom. Other creatures we have photographed in the deep sea are crabs, holothurians, isopods, and amphipods; and it is an unusual photographic sequence that does not include some shrimp, often quite large. We also have rare pictures of octopuses, including one attracted to an orange we had used for experimental bait.

The environment of the very deep creatures is without light, except for bioluminescent flashes. The water temperatures range from  $-2^{\circ}\text{C}$  in the Antarctic waters to  $1.5^{\circ}\text{C}$  in the Pacific deep near-bottom, and water pressures are 400–700 kilograms per square centimeter. Sea floors range from soft silica ooze in the Antarctic to dense beds of manganese nodules in the central basin of the North Pacific.

One of the more puzzling questions in benthic studies is: What is the food source of the active scavengers of the deep-sea floor? The deeper floor of the ocean far from land cannot develop a food web from particulate debris that would provide any substantial food supply for larger fish. It may be that the grenadier, the greatest component of the deep near-bottom biomass, gorge themselves when large fish or mammals die near the surface and sink to the bottom. Recent studies of stomach contents of grenadier near land at 2500–4000 meters show they feed some distance off the bottom in the midwater, and there is clear evidence that they are not too particular about their food. Cephalopods were found to be important in their diet, but the stomach contents included potatoes, onions, rubber, and plastic.

In one mid-ocean area in the western North Pacific near the location of a weather ship, 41 large grenadier were photographed in one frame over a manganese nodule bottom. The water column above is not considered a productive zone, but it is a migratory route of tuna, as well as a Japanese tuna fishing ground. The grenadier may have ample food from the weather ship's garbage and dying migrating tuna. It may be that these very deep open-ocean fish are concentrated along shipping lanes and the migratory routes of fish and marine mammals, particularly under the most unproductive waters where lack of food may exhaust the reserves of old and ailing migrants.

Another free-vehicle camera, recently developed by Daniel Brown at Scripps, is used to identify pelagic fish schools and to estimate their density. This system is lightweight and easily tossed overboard as the ship passes over a school of fish. The camera automatically takes pictures every 15 seconds and is ballasted so that it sinks slowly. After a certain depth is reached, it releases the ballast and returns to the surface for recovery. If the camera sinks to a shallow bottom, a back-up release—employing dissolvable candy, ice, or salt—triggers the ballast release. The entire system is cheap and easy to operate, and results can be obtained very soon after recovery.

Our present use of Brown's "drop camera" has been the identification of pelagic fish schools off the coast of Southern California and Baja California. Although the number of schools and their size can be determined acoustically, positive identification is not yet possible by this method. With the new camera, positive identification and density can be obtained, which then help in determining the biomass of these pelagic fishes.

The application of free-vehicle cameras has only begun. To collect valuable records, vessels using the system need be neither large nor specialized, and pictures may be taken at specified intervals and depths while the ship carries out other work. Developing countries, for example, could conduct surveys of both pelagic and benthic resources on their continental shelves and down the slopes to the abyssal plains. Along the United States coasts, studies of the behavior of, for example, the lobster around a baited trap may answer such questions as: Has the persistent fishery selected for the survival of behavioral subgroups of lobsters that avoid the conventional trap? Or: Has the fishery stimulated an unavailable competitor population? Free-vehicle cameras as exploratory tools can help guide fisheries and other developments by allowing visual perception into the dark ocean depths.

*John D. Isaacs is professor of oceanography at Scripps Institution of Oceanography, University of California at San Diego, and director of the University of California Institute of Marine Resources. Richard A. Schwartzlose is a researcher in physical oceanography and academic administrator of the Marine Life Research Group at Scripps.*

# Photography from a Submersible during Project FAMOUS

Robert D. Ballard

Manned submersibles are unique and highly specialized tools from which scientists make firsthand observations in the deep sea. These research vessels are most often used by marine biologists and geologists whose work involves a high degree of qualitative investigation, much of which is recorded on film. Limited horizontal range, short bottom endurance, and high operating expense require that submersibles be used in regions of complex composition and high scientific importance. In addition, submersible work is usually most productive in areas that have been intensely investigated through conventional surface ship operations, where specific problem areas have been identified for detailed studies from these vehicles.

The number of scientists who can properly utilize a submersible, the need for careful selection of a research area, and the years of preparation that may go into site surveys have limited the number of investigators capable of defining and carrying out a meaningful submersible program. Of those that could, many are content to stop at the surface ship stage and not get involved in this newer technology.

Despite these handicaps, submersible techniques have improved dramatically in recent years, at a time when interest in detailed studies has increased. From 1964 to 1974, the research submersible *Alvin*, for example, had to pass through a series of developmental steps before it was capable of shouldering the responsibilities of a major science program. *Alvin* had to become an operationally reliable vehicle to the point where successful dives became routine. The submersible also needed a precision navigation and data logging system that would permit scientists to make observations within a frame of reference accurate enough to obtain unique insight into bottom processes (see page 40). At the same time, *Alvin* had to undergo a major modification to reach 3600 meters, the average depth of the oceans.

Within the same time frame, earth scientists' understanding of the sea floor evolved rapidly. In the early 1960s the major emphasis was on obtaining a fundamental understanding of the various geological provinces of the world oceans. Clearly, this approach required a series of world-wide cruises, not submersible operations. From this work came the delineation of continental margins, abyssal plains and hills, and, more important, the recognition of a global network of fracture zones, deep trenches, and extensive mid-ocean ridges. This realization was followed by an even more fundamental discovery: the earth's surface and composition are the result of a complex history of interaction between lithospheric plates. As scientists sought to use the principle of sea-floor spreading to explain the earth's past behavior and to predict its future activity, a greater and greater need developed to describe in detail the boundaries of the plates and their interaction with one another.

## A New Approach

Since the Mid-Atlantic Ridge is one of the primary regions where new lithosphere is being formed as Europe and Africa move away from North and South America, studies of this undersea mountain range became increasingly important. Intense surface ship studies of the Ridge conducted during the past five years have resulted in a better understanding of the forces responsible for plate genesis and subsequent motion. As these studies progressed, a growing number of scientists began to believe that an entirely different approach was needed to provide new insight into the tectonic and volcanic processes at an active zone of sea-floor spreading. Attention then turned to submersible operations at a time when they had reached their highest state of readiness. The result was Project FAMOUS and its related field programs.

Project FAMOUS (French American Mid-Ocean Undersea Study) was a detailed investigation of a small portion of the Mid-Atlantic Ridge rift valley, 448 kilometers southwest of the Azores (see maps). The four years of field operations associated with this program included most major investigative techniques: the drill ship *Glomar Challenger*; the Naval Research Lab's large-area photography system, LIBEC (LIght BEhind the Camera); Scripps' towed instrument system (Deep Tow); England's large-area side-scan sonar (Gloria); bottom-setting seismographs; and Woods Hole Oceanographic's small-area geological survey system (Angus), which was used to track and locate towed cameras, temperature sensors, dredges, bottom sediment corers, and a diamond-bit drill unit.

Prior to diving operations in the summer of 1974 by *Alvin* and the French submersible, *Cyana*, and bathyscaphe *Archimede*, a series of cruises were conducted in the FAMOUS region using a variety of photographic methods included in the operations listed above. Although these techniques provided valuable information about the geology of the rift valley, dives in the same region resulted in a large number of new observations, many of which were documented by bottom photographs taken from *Alvin*.

In all, approximately 100,000 photographs were taken as part of the American effort in the FAMOUS study area. This includes 15,000 photos taken by *Alvin*, of which 2500 were color exposures, the first such taken in the rift valley. Two 35mm EG&G cameras were mounted in *Alvin*'s brow, overlooking the area directly in front of the submersible (see drawing). They had lenses with a focal length (underwater) of 50mm and were spaced 15 centimeters apart to permit stereo coverage.

The cameras were controlled from within the submersible and could be operated automatically or manually. In general, we used them in an automatic mode when we were underway in an effort to obtain a near-continuous documentation of the terrain covered during any one dive. We found that at the slow speeds (0.5 knot) at which the submersible operated in this rugged terrain, a 10-second repetition rate provided an average 10-15 percent overlap in photo coverage. We seldom ran the cameras in stereo mode; the region we covered required more exposures than one camera contained (500 frames), and we therefore used them in series. Film was shot at 1/25 second and approximately *f*/5.6. In the rift valley, only black-and-white film was used on the first 13 dives. On the last 4 dives, both black-and-white and high-speed Ektachrome were employed.

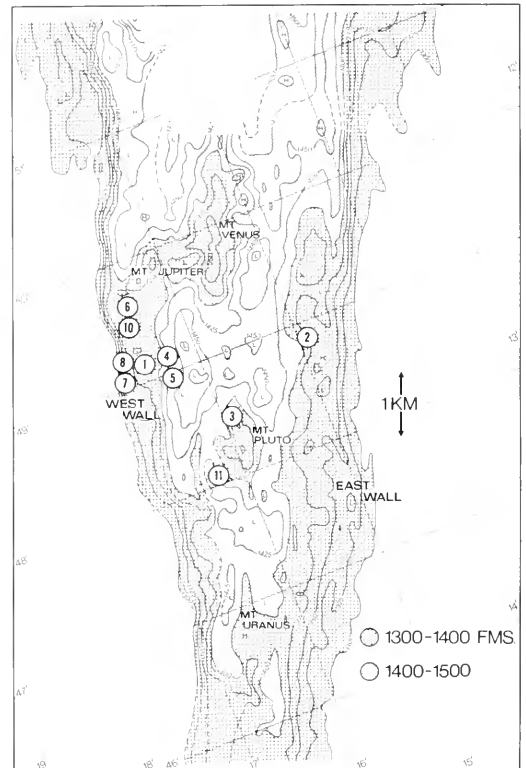



(Top) Square indicates area of FAMOUS operations on the Mid-Atlantic Ridge. From late June through August 1974, three deep-diving submersibles—two French and one American—made some 40 dives into the rift valley and associated fracture zones. (Bottom) Detailed map of the dive site. Circled numbers are keyed to figures in this article and roughly indicate places where photographs were taken. (Top: Atlantic Ocean Floor map © 1973 by National Geographic Society. Based on bathymetric studies by B. C. Heezen and Marie Tharp)

Profile of Alvin showing principal scientific instrument systems. (Drawing by Edward L. Bland)

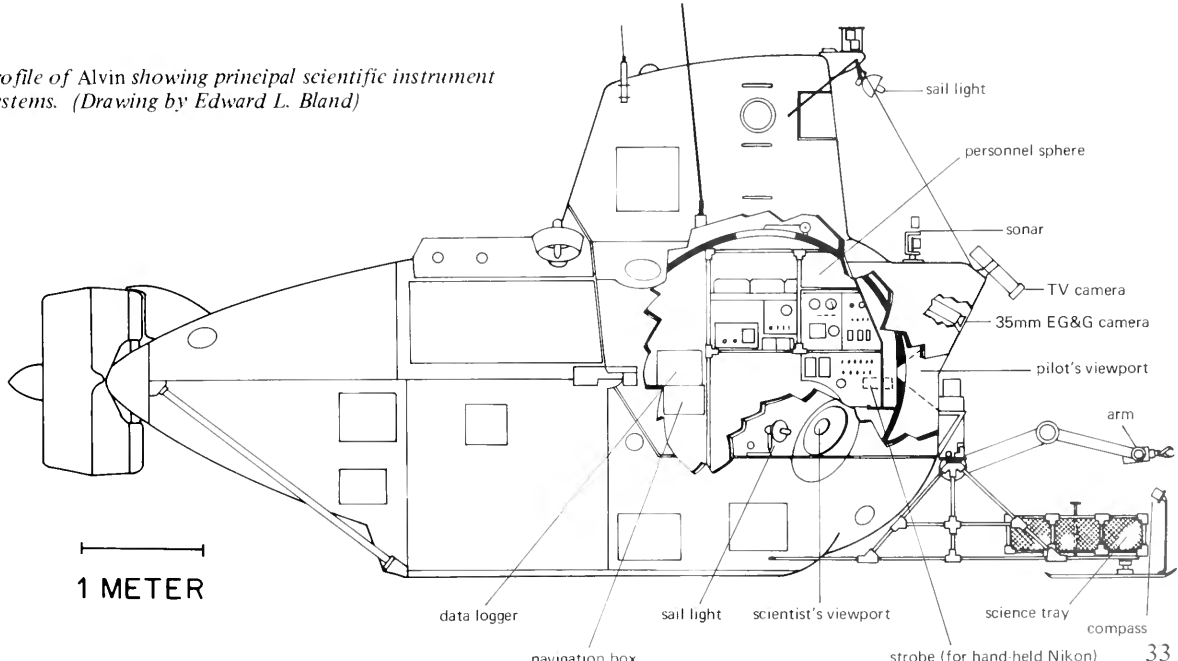

The two scientists inside the pressure sphere used hand-held Nikon cameras with a variety of lenses for close-up pictures of important biological and geological features. The observer held his camera, synchronized with an external strobe light, to his viewport, focused it on the object, and fired. High-speed Ektachrome and black-and-white films were used, shot at 1/60 second and approximately f/5.6. The most useful lens proved to be a 43–86mm zoom, with which it was possible to enlarge and properly frame features without having to move the submersible. With the use of external running lights, the observer could check his focus before taking a picture.

### Haystacks, Lava Tubes, and Pillows

One of the objectives of Project FAMOUS was to locate central sources of volcanic activity. Analysis of photographs taken from the surface revealed none of the central vents or craters common in terrestrial volcanic regions. From the submersible, however, scientists observed features resembling spatter cones, which indicate central sources of volcanism. These structures, termed “haystacks,” or “flow cones,” averaged 5 meters in height and 7 meters at their base—too large to be photographed by conventional techniques. Figure 1 is a haystack mosaic, composed of photographs taken with *Alvin*'s



*Figure 1. Mosaic of a haystack, or flow cone, approximately 5 m high and 7 m across the base. In this mosaic and those in Figures 6 and 10, the photos have been individually developed to match or blend one photo with those on either side, in an attempt to present the feature as it was observed firsthand.*

external 35mm camera.\* After firsthand observation of the haystacks from the submersible, LIBEC photographs were reexamined and four of the structures were recognized. Combining the detail obtained from the submersible with the large-area perspective of LIBEC, it was possible to see the pattern of pillow tubes radiating from the haystack and their overall distribution.

Another contribution from the submersible was a much better understanding of the presence and structure of master lava tubes, which serve as feeders to a complex series of lava flow-fronts extending from the central volcanic zones. Figure 2 is a close-up photograph of the interior of a master lava tube, taken through *Alvin*'s viewport with a Nikon camera. Because of the high degree of maneuverability in a submersible, it was possible to position the scientist's eye less than 0.5 meter away from such important geologic structures. This photo and others like it reveal a series of "high lava" marks showing the various levels at which



Figure 2. Interior of a master lava tube, approximately 1.5 m across.

lava flowed when the tube was actively supplying lava to the flow-fronts farther downslope. Knowledge of these flow levels made it possible to take samples collected by the submersible as well as previous dredging operations and orient them in the laboratory with respect to up and down.

By traveling over one lava flow after another, we began to recognize a continuous repetition of several basic lava forms. Photos taken with surface cameras revealed similar shapes, but since these were shot vertically rather than obliquely, it was not possible to see the relationship of lava forms to the slope of the flow-fronts or to determine their actual dimensions or shapes. Figure 3 is a

\*Photographs in this article were taken at depths ranging from 2730 to 2820 meters.

photo taken with a hand-held Nikon camera of two typical pillows, which are found on the flows at the end of the lava tubes, like fingers projecting out of the flow. In this photo one can see the detailed surface of a pillow showing the growth marks that



Figure 3. Pillow formations with growth marks. Top pillow is about 1 m long and 0.5 m across.

were etched in the lava as it erupted into the sea and quickly cooled. Another common lava form is the trap door (Figure 4), a pillow whose top was lifted up, forming a cap attached to a column of newly extruded lava.



Figure 4. Trap door lava. Door is 0.5 m across and uplifted 20 cm.

### Fissures and Faults

Observations coupled with photography were of great value in the regions of tectonic activity to the east and west of the central volcanic zone. As the submersible traveled away from the major lava flow-fronts, out across the inner rift valley floor towards the steep walls flanking the valley, it encountered a large number of fissures and faults produced by the pulling apart of the newly created sea floor. Here again, surface-towed cameras revealed the presence

of these features, but a great amount of detailed information came out of submersible observations and photographs.

Once a fissure was encountered, it was possible to drive the submersible along its length and observe its changing character—something beyond the capability of surface-towed cameras. It was common, for example, to spot a pillow cut in half by a hairline crack and to follow along the crack until it opened several centimeters and revealed a deep split in the sea floor. Careful inspection of these small features also showed differential motion between the two sides of the crack. In Figure 5, for example, one can see that the side closer to the viewport has dropped down 15-20 centimeters relative to the other side. This important geologic relationship would not have been noticed in a photograph taken by a surface-towed camera aimed straight down, assuming the crack itself had been detected.



*Figure 5. Small hairline fracture that has opened 5-8 cm. The two sides have moved vertically 15-20 cm relative to each other.*

Farther towards the base of the valley walls, it was common to encounter larger fissures in an otherwise sediment-covered bottom (Figure 6). Examination of these large features showed that the sediment blanket was only a few centimeters thick, beneath which were circular rock-units characteristic of lava flows that had been cut by tensional faults. As we traveled along these large fissures, we could see delicate pillows perched over the wide chasm (Figure 6).

One of the areas in the rift valley where photography from the submersible made its greatest contribution was in the regions of the east and west walls, where major vertical uplifting was taking place. Because of the steepness of these fault scarps—which had near-vertical slopes, even overhangs—detailed examination using surface-towed cameras was virtually impossible. Beginning



*Figure 6. Mosaic of a large fissure, with sediment-covered pillows perched over the chasin, about 4 m wide.*



at the base of one of these major fault scarps, observers in *Alvin* could see and photograph the vertical face and the series of scratches or gouges caused as one block moved up relative to another



Figure 7. Fault scarp showing gouges formed as one section of the face moved up relative to another.



Figure 8. First photograph of an underwater dike (arrows) exposed in the west wall.

(Figure 7). Driving up the fault face, within inches of it, we used hand-held cameras to record the various layers of material exposed in the wall. For the first time, it was also possible to observe and photograph dikes (Figure 8), which are long, narrow crosscuttings of rock intruded, while molten, into a fissure in older rock.

### Two Perspectives

A comparison between photographs taken by LIBEC and those by *Alvin* illustrates the advantages and disadvantages of the two systems and provides insight into what might lie ahead in underwater photography. Figure 9 is a mosaic of seven LIBEC photographs, with *Alvin* shown to scale. Two parallel fissures are seen cutting across the rift valley floor for a distance of approximately 50 meters.

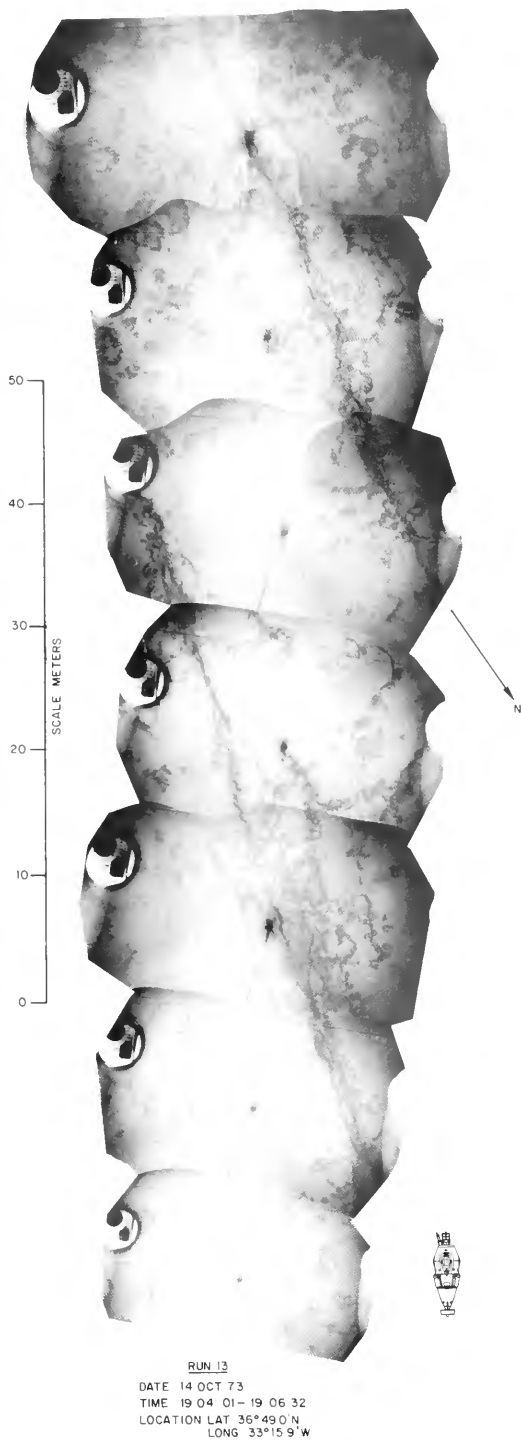

Figure 9. LIBEC mosaic of two parallel fissures on the rift valley floor, with *Alvin* (top view) shown to scale. (Mosaic courtesy of Naval Research Laboratory)

With LIBEC it is possible to obtain large-area photographs of the sea floor, with which one can easily determine the trend of the fissures, their relationship to one another, and their behavior along their length (width and nature of fracturing). It is, however, extremely difficult to know the vertical relief of the faults or the nature of the rocks exposed by the deep fault. Figure 10, on the other hand, is a crude mosaic of photographs taken from *Alvin* along a similar crack in the rift valley floor. In these

photos one can see the detailed nature of the fault face where there is a continuous series of truncated pillows, characterized by circular patterns of radial jointing. It is also important to remember that a scientist is observing these structures on a real-time basis inside the submersible and can direct the pilot to drive along the feature until he has had an opportunity to fully describe it.

In the LIBEC mosaic one also notices numerous circular-looking features filled with

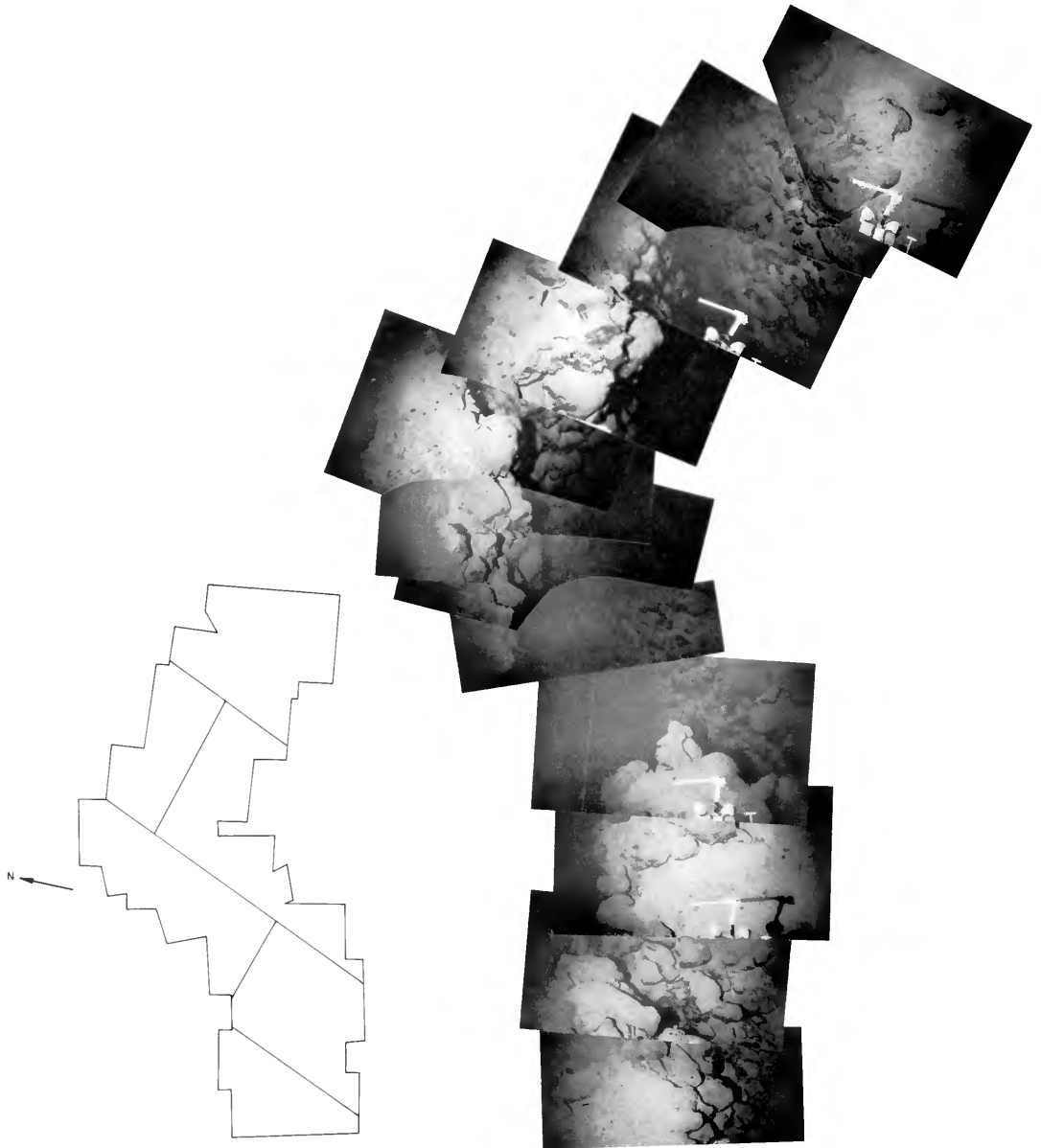

Figure 10. Mosaic of photos taken from *Alvin*. The fissure, approximately 4 m wide and located on the rift valley floor, is similar to those in Figure 9. Arrow indicates radial jointing seen in fractured pillows.

sediments. Figure 11 is a photograph of one of these features taken from *Alvin*. While the LIBEC photos give an idea of their size and distribution, the *Alvin* picture shows they are collapsed pillow-blisters that expose the internal structures of tubes through which lava traveled. The LIBEC and submersible systems are complementary, and efforts are being made to combine the two approaches by suspending a LIBEC-type system above *Alvin* so that scientists can obtain photographs of the two different perspectives of the same feature at the same time.



*Figure 11. Collapsed pillow-blister reveals internal structures of lava tubes. This feature, photographed from Alvin, appears in Figure 9 as circular shapes filled with sediments. Blister is about 1.5 m in diameter.*

### Prospects

Going to such places as the Mid-Atlantic Ridge is sparked by a basic desire to better understand the behavior of the earth, not by a perpetual fascination with the submersible that took us there. Past developments at Woods Hole have grown out of scientific need. After a long and time-consuming development, *Alvin* has reached an operational configuration that can undertake a large number of challenging problems. The emphasis in the near future should be on encouraging more scientists to undertake programs such as FAMOUS that require careful and lengthy preparation but that have meaningful scientific results. Prospects look bright; many of the American and French scientists involved in Project FAMOUS are proposing a series of comprehensive programs at other plate boundaries such as the Cayman Trough, Panama Basin, Peru-Chile Trench, and Vema Fracture Zone.

*Robert D. Ballard is an assistant scientist in the Department of Geology and Geophysics, Woods Hole Oceanographic Institution.*

*The author wishes to thank his scientific colleagues who dove with him in Alvin and J. R. Heirtzler who was chief scientist of the American 1974 FAMOUS operations. The other U.S. diving scientists were W. Bryan, Woods Hole Oceanographic Institution; G. Keller, National Oceanic and Atmospheric Administration, Miami, Fla.; J. Moore, U. S. Geological Survey, Menlo Park, Calif.; and Tj. van Andel, Oregon State University.*

# Improving the Usefulness of Deep-Sea Photographs with Precision Tracking

Robert D. Ballard

For the last thirty years, hundreds of thousands of photographs have been taken of the deep-sea floor. Only a small percentage of these photos have been published; the rest have ended up in numerous archives, waiting to be reviewed by other scientists, few of whom ever look at them. One of the major reasons for the lack of follow-up studies is that the photographs cannot be easily and accurately oriented in time and space. That is, unless one knows the size of the area photographed, the direction the camera was pointing, and the relationship of one photo to the next and to the bottom topography, the pictures cannot be quantitatively analyzed.

In the past, photographs were used to obtain a general, qualitative picture of the sea floor in an effort to understand some detailed characteristics of various sea-floor provinces. However, the photos were not used as a primary mapping tool, and once an area was generally described, there was little incentive in reexamining the photographs just to obtain a bit more of the same information. In future deep-sea photography, the emphasis should be on not only carefully storing the photos but also upgrading their usefulness and, hence, their value. Fundamental to such a step is the use of a precision tracking and logging system that references the camera to a network of bottom transponders and records the behavior of the camera as a function of time (i.e., altitude, heading, and orientation relative to the horizontal plane). If the photos are stored along with a record of the navigation track and a log of the camera's behavior, other researchers will be more likely to use this information in their work.

The most recent progress in improving the value of bottom photography was made in the summer of 1974, when the tracking and logging system mentioned above was used in conjunction with diving operations by the U.S. submersible *Alvin* during Project FAMOUS (see page 31). After the work area was selected on the inner rift valley floor

of the Mid-Atlantic Ridge, but before diving operations began, a network of acoustic transponders was dropped to the sea floor from the R/V *Knorr*. With the ship's satellite navigation system and a detailed bathymetric map provided by the U.S. Navy, a baseline survey was conducted to accurately determine the location of each transponder relative to the others and to the bottom topography. In all, five transponders were positioned, at an average of three kilometers apart, in a zigzag pattern down the axis of the valley.

Before each dive, two of the transponders were chosen to track the submersible. The object was to pick the two that provided the best acoustic geometry, then to try to prevent *Alvin* from working near the baseline between them (Figure 1A). When the vehicle approached the baseline of the first two transponders, the tracking accuracy decreased. The navigator therefore advised the submersible to change its course; if that was impossible due to scientific considerations, the navigator used a different baseline, involving one of the other transponders.

Over the years it has been found that the best place for the navigator and his equipment is aboard the surface ship, not in the submersible using up valuable space and power (Figure 2). During Project FAMOUS, *Alvin* was tracked from a van mounted on the bow of the mother ship, *Lulu* (Figure 3). Every 20 or 30 seconds, *Lulu* transmitted an interrogation signal to the transponders (Figure 1A). The time required for their responses (each on a different frequency) to reach the ship was combined with their known locations to determine *Lulu*'s position, which the computer then plotted on a topographic map of the area. This was followed by an interrogation signal to the transponders from *Alvin* (Figure 1B), whose internal clock had been synchronized with *Lulu*'s just before the dive had begun. *Alvin*'s signal and the subsequent responses from the transponders traveled to the surface ship. Since *Lulu*'s position relative to the topography had

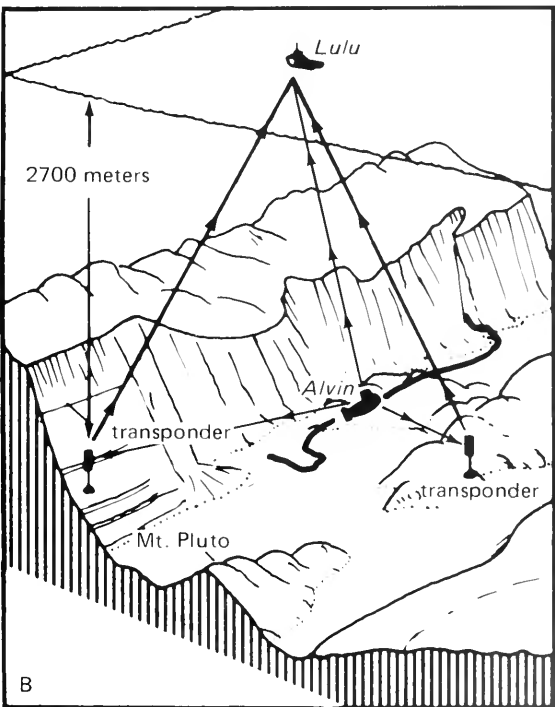
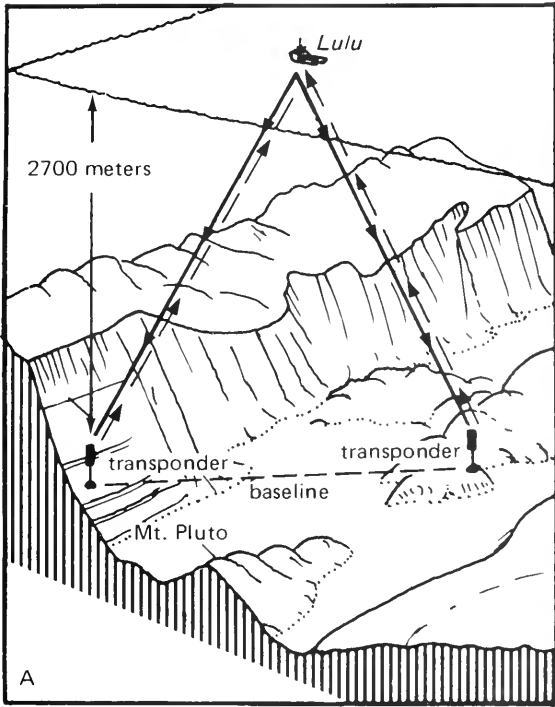

Figure 1. Schematic drawings of transponder tracking system used during Project FAMOUS. Topography shown has 2:1 vertical exaggeration and covers the area where the dives took place. (A) Acoustic paths for Lulu interrogation. (B) Acoustic paths for Alvin interrogation, along with the track of Dive 535 superimposed on topography.

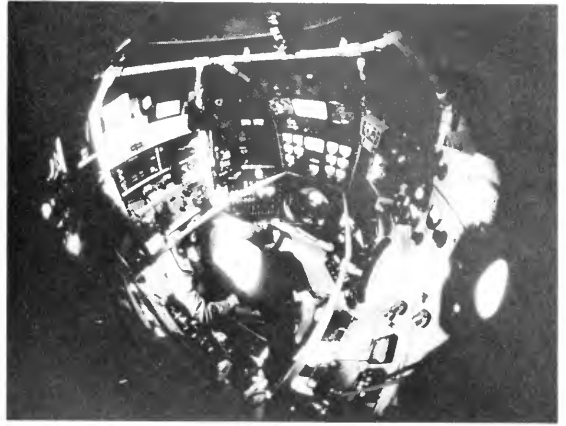

Figure 2. Inside Alvin's personnel sphere, taken with a fish eye lens. Pilot is at center, with scientists to his left and right. (Photo by R. D. Ballard)



Figure 3. Inside the van aboard Lulu from which Alvin is tracked. Numbers in upper left-hand corner are travel times from Lulu or Alvin to transponders and back. This information is fed to small computer to the right, which performs a series of calculations before plotting Lulu's or Alvin's position on the x-y recorder, to its right. Author is editing raw data while monitoring the computer plot.

just been determined, *Alvin* could be located relative to *Lulu*, and therefore to the bottom. With these calculations completed, the computer then plotted *Alvin*'s position on the topographic map.

While working on the bottom, the scientists needed to be given (via telephone) only 10 or 12 positions during the dive to know their general location (although after the dive they wanted to know the submersible's track as accurately as possible). The topographic map on which the computer plotted *Alvin*'s position every 20-30 seconds had an x-y reference system printed on it. With an identical chart in hand, the scientists telephoned, "*Lulu*, this is *Alvin*. May I have a fix?" And the reply was, for example, "*Alvin*, this is *Lulu*."

Your 1230 and 30 second fix is  $x = 42.35$ ,  $y = 108.85$ ." With this information the scientists in the submersible quickly plotted their position (one held the flashlight while the other recorded), made a decision about what to do next, and moved on.

During the dive the scientist aboard *Lulu* who was serving as navigator continuously reviewed the raw data and edited it to remove bad information. For example, a response reflected off the steep walls of the valley often created a ghost plot, indicating the submersible was elsewhere. This was compounded by another factor. It was important that the navigator not let bottom features, such as steep ridges, come between *Lulu* and *Alvin* and disrupt the tracking system. He therefore had to continuously move *Lulu* from one side of a feature to another, always staying one jump ahead of the submersible. If he followed a ghost plot and got too far away from the sub's actual position, he had to ask *Alvin* to stop while they tried to find the vehicle, which resulted in the loss of bottom time.

At the end of the dive, the final edited data were replayed on the larger computer aboard the escort vessel *Kuorr* to produce a final x-y plot, with an accuracy of 10-15 meters. This navigation track was then superimposed on the topographic map (Figure 4).

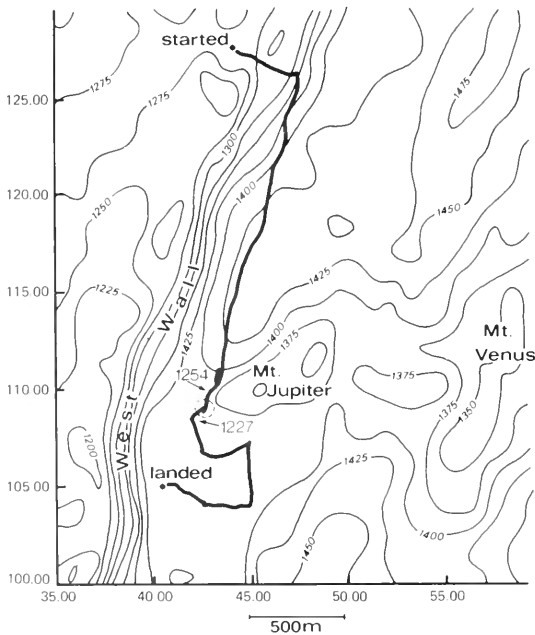

Figure 4. Final computer plot of Dive 535 superimposed on that portion of the topography of the rift valley floor. Numbers along axes pertain to the x-y reference system used to transmit *Alvin*'s position from *Lulu* to the scientists below. Numbers along track refer to time. Broken circle represents the area shown in Figure 7. Topography has 25-m contour interval.

*Alvin*'s behavior as a function of time was recorded inside the submersible on a 10-centimeter-wide 8-channel analog recorder (Figure 5). Every

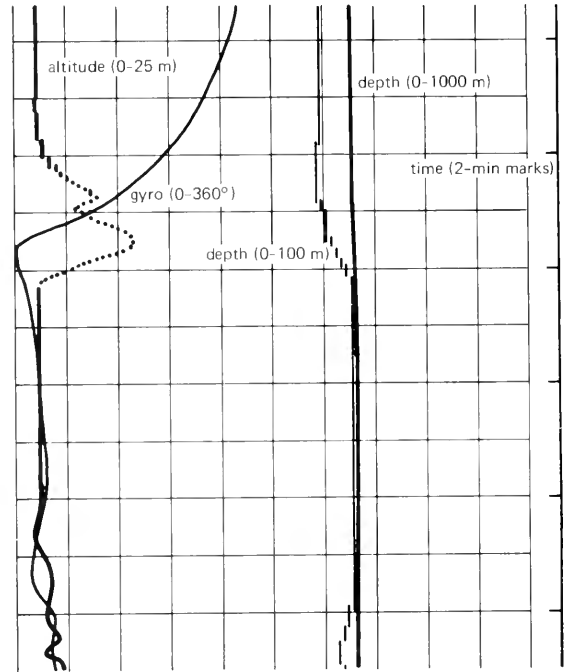

Figure 5. Portion of an analog recording of *Alvin*'s behavior as a function of time during a segment of Dive 535.

few seconds four parameters were noted: Altitude off the bottom ( $\pm 0.3$  meter), depth of water on scales of 0-1000 meters and 0-100 meters, and gyro heading ( $\pm 2$  degrees). In the right-hand margin of the recording, a time tick was marked every two minutes, based on the precision navigation clock. After the dive, this information can be employed for a variety of functions. For example, using the submersible's depth and altitude, it is possible to generate a detailed bottom profile (Figure 6). In addition, with the x-y plot (Figure 4), and *Alvin*'s heading, depth, and altitude as a function of time (Figure 5), one can precisely position photos taken from the submersible along the dive track. Figure 7 shows a segment of the track presented in Figure 4 (broken circle) where the scientists investigated a portion of the rift valley floor that had been broken up by a series of tensional fractures. Since the data board shows the time a photo was taken (see, for example, page 13), each picture can be accurately positioned along this track in its correct orientation, forming a crude mosaic of bottom features. The actual position and orientation of the photo mosaic in Figure 10, page 38, for example, is shown in Figure 7. After this

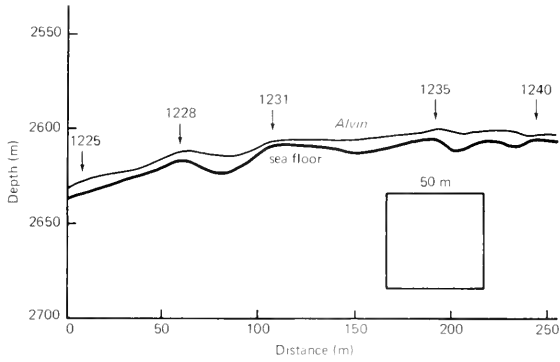

Figure 6. Bottom depth and submersible altitude plot as a function of distance traveled. Data used to generate this bottom profile were taken from analog recordings made aboard Alvin (Figure 5).

Robert D. Ballard is an assistant scientist in the Department of Geology and Geophysics, Woods Hole Oceanographic Institution.

The author wishes to thank his scientific colleagues who dove with him in Alvin and J. R. Heirtzler who was chief scientist of the American 1974 FAMOUS operations. The other U.S. diving scientists were W. Bryan, Woods Hole Oceanographic Institution; G. Keller, National Oceanic and Atmospheric Administration, Miami, Fla.; J. Moore, U.S. Geological Survey, Menlo Park, Calif; and Tj. van Andel, Oregon State University. The author also thanks William (Skip) Marquet who, along with other members of the Alvin Group, developed the precision transponder navigation system used during Project FAMOUS.

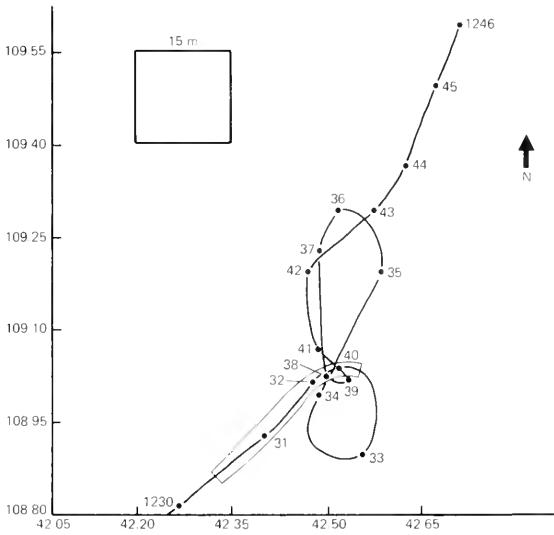

Figure 7. Enlargement of the navigation track within the broken circle in Figure 4. Blocked-off portion of track indicates area and orientation of photo mosaic in Figure 10, page 38.

work has been done, a geologist can map the fractures, showing their direction (strike) and the amount of vertical and horizontal motion, as well as make a variety of other important geological observations.

Since the photographs taken during Project FAMOUS have been stored with a set of navigation tracks and submersible logs, scientists who were not involved in the program can review the material for their own purposes and quickly determine where the photos were taken. Photography in conjunction with precision navigation and logging provides an opportunity for insight into deep-sea environments not previously possible.

# *Photographic Clues to the Origin of Earth's Oldest Oceans*

*W. B. Bryan*

Most of the literature on sea-floor volcanic rocks is limited to chemical analyses of the rocks, and such inferences as have been made about their origin and the history of the sea floor necessarily have been restricted to hypotheses involving their geochemical evolution. Over the past several years, we have made extensive use of photography to develop a comprehensive view of the role of volcanic activity in the geologic evolution of planetary bodies and, in particular, to clarify the role of volcanic activity in the early history of ocean basins on the Earth. This photography ranges in scale from micrographs of crystals a few microns in diameter within sea-floor rocks, to spacecraft photos of the Earth and Moon covering thousands of square kilometers. As might be expected, the consequences of this wide-ranging effort are, in some respects, mind-boggling.

Photomicrographs of sea-floor basalts show a variety of bizarre chain-like, fern-like, or box-like crystal forms that result from the unusually rapid quenching of molten rock erupted into cold sea water (Figure 1). In most cases, the shapes of these crystals are distinctive and allow identification of the mineral even when it is too small to be analyzed by the usual methods. If the original mineral has been destroyed by chemical changes in the rock, its "fossilized" form may remain and can provide an important clue to the original composition of the magma from which it crystallized. The delicate shapes and small size of these crystals cause them to respond almost instantly to changes in physical conditions. Any major episode of heating or deformation of the rocks will destroy them.

An exciting consequence of this work has been the recognition of the close similarity between

crystal forms in modern submarine lavas and those in lavas over 3.5 billion years old, which are found in the ancient Pre-Cambrian shield areas of Canada, Australia, and South Africa. This demonstrates that many of these continental rocks are similar in composition to their modern sea-floor counterparts and, furthermore, that they have survived without major deformation or reheating throughout most of geologic time. Such evidence is most remarkable in view of the crustal mobility implied by plate tectonics. At least the oldest, central cores of the continental land masses appear to have been protected from the destructive effects of subduction and continental collisions.

The similarities extend even to the gross form of the ancient continental lavas (Figure 2). In cross section, where exposed in fault scarps or artificially by road cuts, they show the rounded, bulbous forms of submarine pillow lavas. In three dimensions, they resemble a stack of sausages, a form typically recorded in both shipboard and submersible photos of submarine lavas encountered during Project FAMOUS (see page 31).

The implications of the newly documented observations on sea-floor lavas and ancient continental lavas were reviewed at a symposium held at Queen's University, Kingston, Ontario, on October 4 and 5, 1974. It was recognized that these pillow lavas provide the best evidence to date for the existence of shallow seas or widespread lakes as long as 3.5 billion years ago. Speculation centered on the nature of the basins containing these seas, and it was generally agreed that deep and extensive rifted oceans like the Atlantic did not exist that long ago. The presence of ancient circular structures somewhat resembling lunar meteorite craters has





Figure 1. (Left) Reflected light interference contrast photograph of polished basalt surface, showing angular crystals of olivine and diffuse, elongated crypto-crystalline feldspar at 440x magnification. Sample is from JOIDES Site 14, South Atlantic. (Right) Transmitted polarized light photograph at 440x magnification, showing quenched olivine crystals in glass from 150-million-year-old basalt from JOIDES Site 105, northwestern Atlantic.

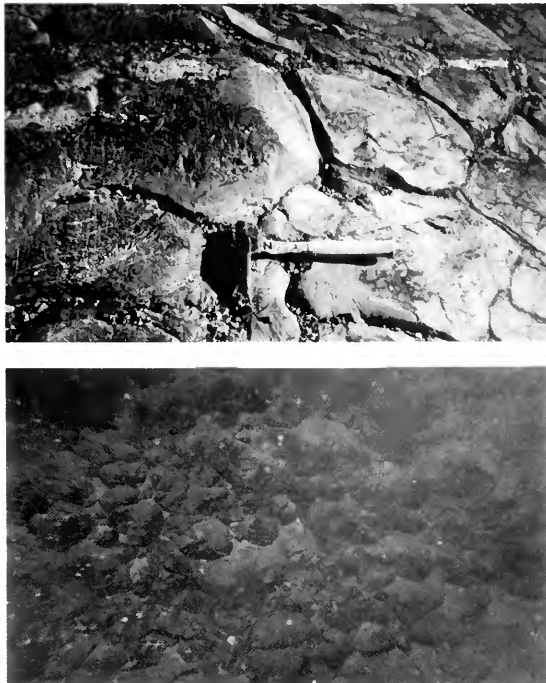

Figure 2. (Top) Archean pillow basalt from Wawa, Ontario; courtesy of Dr. T. H. Pearce, Queen's University. (Bottom) Pillow lava cliff in FAMOUS area, Mid-Atlantic Ridge, photographed by the research submersible Alvin.

long been recognized in older parts of the continents, and this led to the suggestion that the early "seas" were ponded in meteorite craters.

Our studies of lunar meteorite craters have indeed shown that some have floors flooded by dark lava (Figure 3). While the morphology of the main crater does show all the characteristics of an impact origin, some minor craters within it, particularly those associated with the dark lava fill, are not easily explained by impact, but can be interpreted as part of a sequence of volcanic cone-building and lava eruptions. There are indications that considerable time elapsed between the crater-forming impacts and the flooding of the craters by lava. Thus, similar features on the Earth might

indeed have filled with water before the lava was erupted there.

These results have encouraged us to pursue, through photographic studies, another major problem: the origin of the prominent fracture zones that traverse the sea floor. A preliminary study of fracture patterns on the Moon has already confirmed the existence there of a very old and persistent pattern that originated soon after the formation of the Earth-Moon system some 4.5 billion years ago. A review of an extensive literature on the subject suggests the existence of a similar pattern on the Earth, again apparently originating in the very ancient Pre-Cambrian crustal rocks (see Figure 4). These patterns are just beginning to be

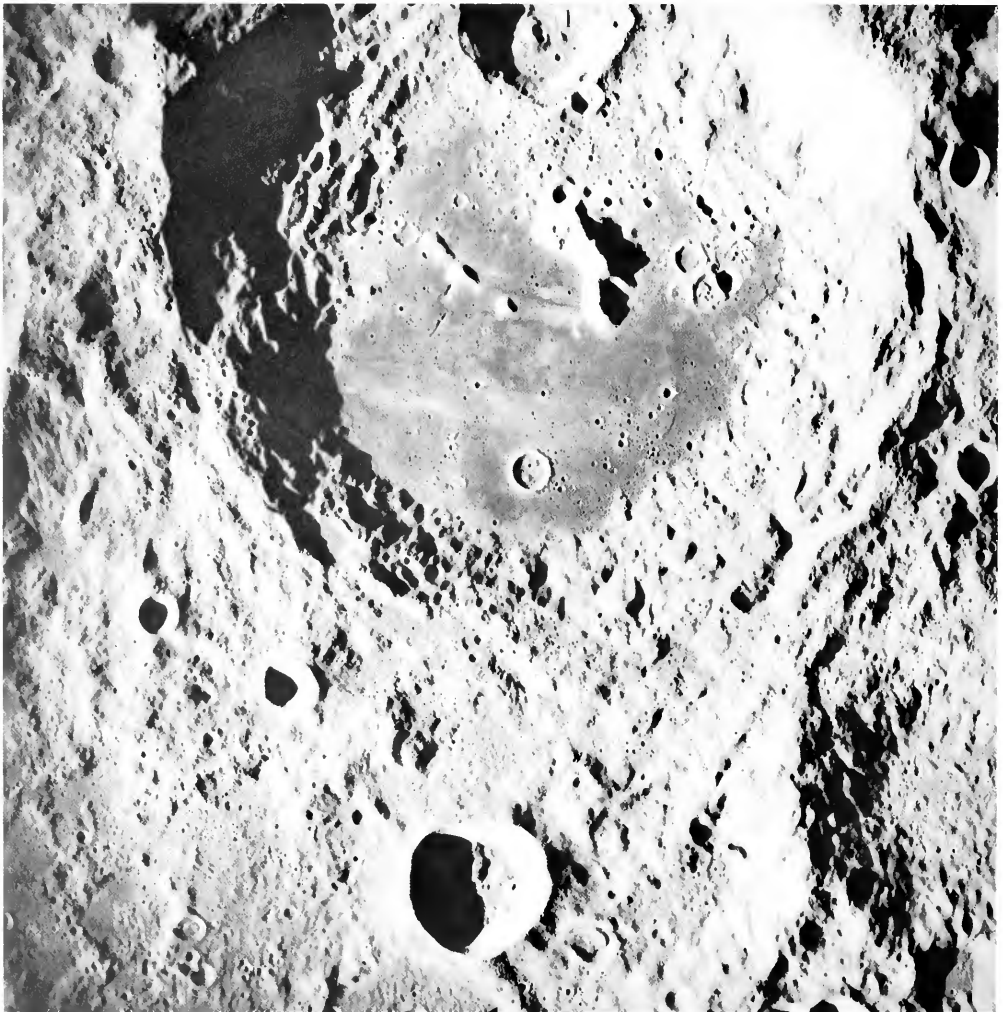

*Figure 3. Crater Aitken as photographed by a specially designed spacecraft mapping camera on Apollo 17. This crater on the far side of the Moon is believed to have been formed by meteorite impact, and is now flooded by dark lava that also encloses small circular cones of possible volcanic origin. Diameter of the crater is about 130 km. Similar craters may have been formed on the oldest Earth's crust before it was enveloped by the protecting layer of atmosphere it has today. NASA photo AS17-0679.*



Figure 4. (Top) Spacecraft mapping camera photograph of Apollo 15 landing site (arrow) and surrounding area. Riverlike feature is Hadley Rille. Note pattern of linear fractures that cuts across flat and hummocky terrain and that parallels an ancient pattern of fractures, the so-called lunar grid. Photo covers a square of 150 km on a side. NASA photo AS15-0587. (Bottom) Linear pattern of lakes and rivers following fracture trends in Archean rocks in Ontario, as reproduced in 1911 by the famous geologist W. H. Hobbs. Compare with photograph above. Hobbs speculated that such patterns could be found over most of the Earth's surface, a concept supported by recognition of such patterns on the Moon. (Originally published by The Geological Society of America)

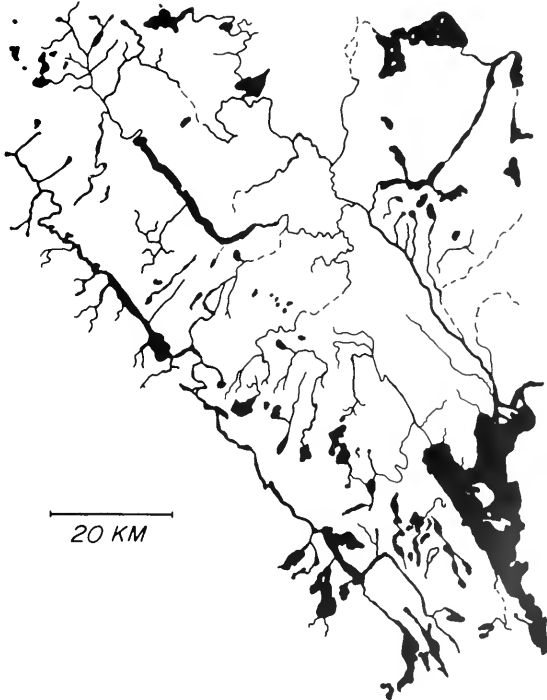

studied in detail on the Earth with the aid of recently acquired ERTS (Earth Resources Technology Satellite) and Skylab photographs. There are indications that some sea-floor fracture zones are continuous with some fracture zones recognized on land, a relation that is difficult to explain unless the older terrestrial fracture zone has somehow controlled the location and orientation of the fracture zone in the young sea floor. In order to better understand these processes, we expect to continue study of fracture patterns in large-scale lunar and terrestrial photographs, and to extend these investigations to the sea floor. Shipboard and submersible operations in two major fractures—the Cayman Trench and the Vema Fracture Zone—are in the planning stage and include programs for extensive photographic documentation of submarine rock exposures. Finally, photographic records of rock samples recovered by dredging and submersibles should facilitate comparison with rocks from known terrestrial fracture zones.

We anticipate that these studies will help to determine whether fracture patterns on the Earth and Moon originated in some common cosmic event very early in their history. We hope to show, again, whether such patterns can persist on the Earth in spite of the complexities introduced by major plate movements. Many mineral deposits on land are associated with major fracture zones. Thus, submarine fracture zones may also be mineralized, and their continental extensions may be the best places to look for new deposits on land.

*W. B. Bryan is an associate scientist in the Department of Geology and Geophysics, Woods Hole Oceanographic Institution.*

# TV in Deep-Ocean Surveys

William D. Siapno

The first scientific survey of the major oceans beyond the continental margins was the Challenger Expedition of 1873. Since then, and with each technological advance, exploration of the ocean depths has increased. Closed-circuit television has recently come of age as a means of examining the deep-ocean floor. Today the impetus is to meet the ever-increasing demand for mineral resources.

Still cameras produced the early views of the sea floor and are still important today. But there are severe limitations. Results are not known

until the pictures are developed, thus creating long delays in obtaining the required information. Poorly focused, incorrectly exposed pictures, as well as equipment malfunctions, are frustrating, time-consuming, and expensive.

Television has been used in hazardous environments to observe explosions, experiments in radiation studies, etc. It was therefore logical to extend its use to the deep sea. Microminiaturization, largely the product of space technology, permitted components to be packaged in compact units to



*Television is deployed from Deepsea Ventures' R/V Prospector, from the main boom on the forward deck. The tripod structure provides an underwater vehicle for the electronic components and a stable platform on the sea floor (see Figure 5).*

withstand the rigors of the deep ocean. Systems were adapted to serve as “eyes” of submersibles and as a tethered package towed by a surface vessel. With the exception of a few bathyscaphes, submersibles are largely confined to the upper few hundred meters. All such vessels are expensive, and because they are manned, great caution must be exercised in their use. Television towed by a cable attached to a surface vessel has proven to be the economic, feasible means of observing and recording the visual characteristics of the sea floor.

### Development

In 1964 Newport News Shipbuilding and Drydock Company initiated a program in manganese nodule exploration using a towed TV system with cables approximately 2400 meters long. (The system suffered numerous problems, the most obvious of which was the lack of reliability.) During this time, it was learned that nodule deposits of greatest economic potential were found at depths below 3600 meters. The simplest answer was additional cable. However, until the late 1960s, TV signals transmitted over a 3600-meter cable had to be amplified. In-line amplifiers required terminations in the cable where amplifiers were inserted, and this seriously diminished cable strength. Furthermore, amplifiers had a larger diameter than the cable, thus preventing smooth spooling and level winding of the cable on a winch drum.

In 1969 Deepsea Ventures, the successor to the ocean program founded by Newport News Shipbuilding and Drydock Company, together with Hydro Products, co-ventured the development of TV operative over 7500 meters of cable without in-line amplification. Art Vigil, electrical engineer with Hydro Products, was largely responsible for this system which brought nearly three-quarters of the sea floor within observable range.

### Equipment

The major components of deep-sea television are the electronic units, which include camera, interface, choke, and lights (see Figures 1 and 5); cable; winch; overboarding mechanism; and ship. Each item must be integrated with other components to function effectively with high reliability. Although it may sound rudimentary, due care and multiple skills are required in the selection, installation, and maintenance of such a system for optimum utilization. All electronic components must be housed so as to be totally waterproof and to withstand the enormous pressures of the deep ocean. Yet they must be easily accessible for maintenance and replacement. The cable serves

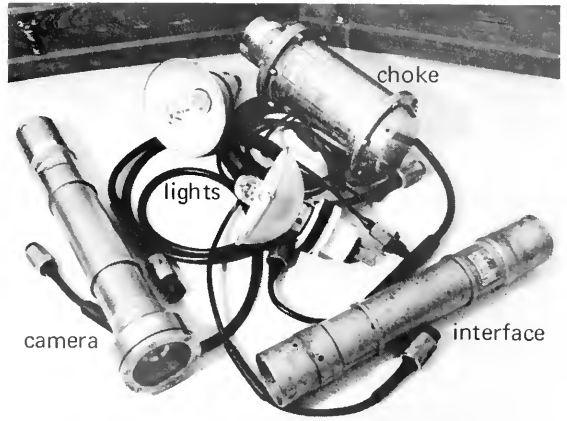

*Figure 1. Submersible electronic components: camera, interface, choke, and lights. The interface distributes the proper power to the various components: the choke separates AC and DC current carried by the cable. All these units are designed for continuous operation at 6000 meters.*

the dual purpose of providing the power to the camera and returning the video signal to the surface. It must also have the structural integrity necessary to support the TV carrier. A non-rotating cable equipped with a coaxial conductor is the most prevalent type. The winch must be capable of rapid hoisting and smooth spooling a large volume of cable. The overboarding mechanism must be able to handle the television on deck as well as under the sea. Articulation must be sufficient to prevent damage to either hull or cable by chafing. The last component, the ship, is very important because it is the platform that provides the support capability as well as the means of conducting the entire survey.

The ocean depths are devoid of light except for the scattered, infrequent occurrence of bioluminescence. Illumination is provided by two 250-watt thallium-iodide bulbs (see Figure 1), which best match vidicon (image tube) sensitivity and have maximum penetration in seawater. They provide the highest illumination for the power available. Because power is limited at the working end of the cable, low-light-level cameras equipped with highly sensitive vidicons are used. Cameras are also equipped with water-compensated viewing ports to eliminate distortion caused by seawater. Although picture quality is less than that of commercial broadcast, 550 lines of resolution of a maximum of 600 lines can be achieved. This provides a high-quality picture that permits ready assessment of the sea floor. Color TV is not in general use primarily because colors are greatly distorted due to the light characteristics. Also, with few exceptions, somber hues of muted tone predominate. With black-and-

white TV, resolution in 9-10 shades of gray with  $5 \times 10^{-4}$  foot-candles of illumination can be achieved.

### Survey Techniques

Initially television was used in "pogo stick" fashion. With this method the TV is lowered, the sea floor observed for a period of time, and the unit hoisted to clear obstacles; the ship is moved to the next station and the process repeated. It is not necessary to recover the TV to the surface unless the next station is at a considerable distance. This procedure capitalizes on the advantage TV offers in immediately assessing bottom conditions. The more effective technique is to tow the TV and keep the floor continuously in view. This way, changes in visual characteristics can be readily observed. Continuous sea-floor scanning for nearly a week is not unusual, and termination after such period is seldom related to TV capability.

Video recording accompanied by verbal descriptions has become an important means of data collection. It provides a permanent record in a real-time format for later review, as well as appraisal by individuals who cannot participate in at-sea activities (see Figures 2-4).

Towing and control of any device on a long cable is, in itself, complex. The cable is a structural entity as well as a conductor. When the towed package is an expensive and intricate electronic device, skill and care in handling are mandatory. In towed mode, several hundred meters of cable may be consumed in the catenary produced by drag. For practical considerations a cable presents the high drag profile of a rigid cylindrical body to the water flow. As towing speed increases, cable drag forces rise rapidly. At low speed the flow is laminar, and only a small amount of cable is needed to account for the drag involved. When cable speed increases to the extent that cavitation occurs, vortices-shedding produces flutter. This strumming of the cable results in a sharp rise in drag, and the length of cable needed to reach the sea floor increases drastically.

At the present, survey speeds are limited to 2 knots or less when a deep-towed package is involved. For example, survey in 4500 meters of water would require roughly 6000 meters of cable to keep the sea floor in view at a speed of approximately 2 knots. The forces acting on the cable are not constant because of changes in ship motion and path of travel, current regimen, etc. Therefore, the amount of cable extended must compensate for these factors as well as changes in sea-floor relief.

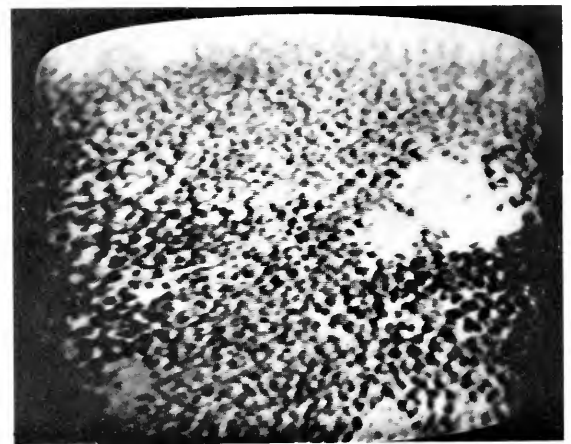
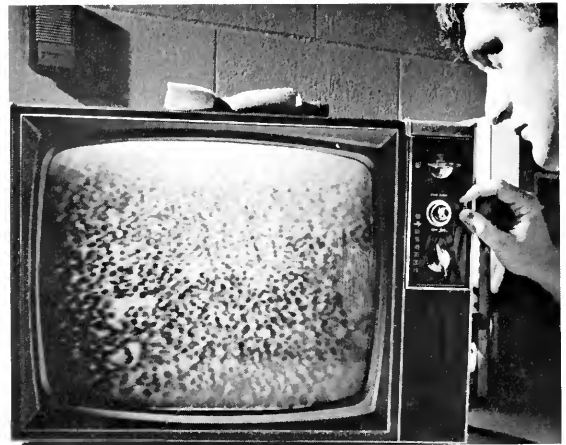

Figures 2 and 3. Replay of TV tape recording of a nodule deposit. Considerable picture quality is lost in photographing the TV screen.



Figure 4. Oceanographer conducting a TV survey. Two monitors are used in the event one should fail. The microphone mounted on the right-hand side of the winch console is used for adding commentary to the TV tape recordings, which allow rapid annotation of important observations.

The general practice is to lower the TV system with the ship moving forward at a minimum speed to maintain the desired heading. When the sea floor comes into view, the speed is increased gradually to a maximum of approximately 2 knots. It has been found that this is the highest speed at which a catenary can be stabilized in a long cable and yet keep the sea floor in view. Several hours may be required during which the length of cable must be adjusted before a stable configuration is reached. Even after "stability" is achieved, small alterations in the extended cable are required to maintain continuous viewing. Despite sophisticated analysis of problems, care and use of long cable systems remains something of a "black art." No two systems, however similar in components, respond the same way; empiricism is the general approach to defining acceptable techniques.

Winch capabilities must be sufficient to rapidly hoist the TV when there are significant changes in topographic relief. At no time while a camera is near the sea floor can the ship be stopped or the forward motion sharply reduced, because the slack in the cable would be disastrous. Cable laid on the sea floor under no tension tends to coil, and when tension is resumed, knots generally form and permanent damage occurs. An acceptable means of splicing TV cables has not yet been found; replacement is expensive and requires a long lead time.

Turning a ship while surveying requires close coordination between the bridge and the survey party. The rate of turn typically is from 2 to 3 degrees per minute (a 90-degree turn takes between 30 and 45 minutes). Throughout the maneuver the winch operator must be certain the TV does not impact the sea floor and permit the cable to go slack. The choice of direction of survey is determined by prevailing sea conditions and ship limitations. Usually a hitch point at the stern provides maximum latitude, but other locations are used, including attachment through a well, or "moon pool,"\* in the hull. There are advantages and disadvantages to each type of installation. At best, all are a compromise in respect to other ship capabilities and limitations.

Another difficulty in towing any package in the deep ocean is determining its location. One cannot assume that the package trails directly behind the ship and passes over the terrain indicated on a depth recorder, which defines the bottom profile directly under the ship. Instead, the towed package is affected by the resultant of the forces throughout the water column and is not propelled solely by the forward motion of the ship. Therefore,

\*On calm nights the moon is reflected in the well.

many times in TV surveying, the observer is startled when the camera collides with an obstacle that has not been noted on the depth recorder. Also the angular width of the depth sounder's beam determines the area insonified on the sea floor, which, in turn, establishes the minimum size of a bottom feature that can be measured. In some cases, a feature appearing quite small may be large enough to create a problem.

It is most important in detail-surveying to know where an observation is made. In general terms, a towed TV system is approximately 50-60 minutes behind the location of the ship but, again, not necessarily directly behind it. With some 6000 meters of cable extended, the system could be well to either side of the path of the ship. This problem is solved by using a complex bottom acoustical navigation system; but for general surveying purposes, such a system is impractical.

Television in other than a real-time mode has found many applications. In slow-scan format, the picture is formulated on the TV monitor and remains for a period, then another picture is developed. The frequency with which the picture is constructed is a function of the system design. Several are in use where the picture on the screen is constituted every 30-45 seconds. The choice of real time or slow scan depends on the application involved and economics applied.

Deepsea Ventures uses a still camera in conjunction with TV. Figure 5 shows the 70mm camera and the strobe light mounted on the tripod. The light is positioned at an angle to illuminate the sea floor so that shadows accentuate nodule shape and size. The camera, manufactured by Hydro Products and modified by Deepsea, contains a data chamber that provides the date and time of each frame. Firing can be controlled by a cam, with time intervals varying from three minutes upward. The period between exposures permits recharge of the capacitors that fire the strobe. A conventional roll of film has 400 exposures; extra-thin film is available that offers 750 exposures. The interval between exposures is determined by the information required, together with the period of time the camera is expected to be on the sea floor. Assuming a picture is taken every 10 minutes, 400 frames would cover 4000 minutes, or 2.8 days.

When used with TV, the still-camera flash appears on the screen. In this way, operation of the system is verified. Since the time between exposures is known, the operator can be certain the sea floor is in range each time a picture is due to be taken. A recent innovation permits pictures

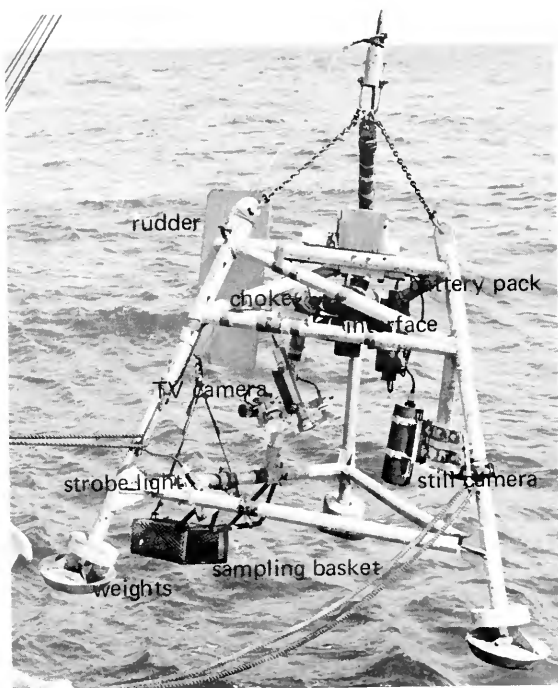

Figure 5. A deep-towed package equipped with TV and still cameras. The TV camera has a 250-watt light on either side. The 70mm still camera is mounted just aft the forward leg; the strobe light is attached to the lower bar in front of the starboard leg. The still-camera battery pack and the TV choke and interface are located above the cameras. Weights on the tripod legs can be changed according to instrumentation in use to balance the carrier. The rudder provides directional stability. Note the small sampling basket used to recover small volumes of manganese nodules for analysis.

to be taken on command, with an acoustical frequency controlling the shutter release. Again, the operator can be certain the sea floor is clearly in view before the picture is taken. Because enlargement reveals greater detail, a 70mm camera was chosen over a 35mm. Figure 6 is a 70mm view of a nodule deposit. Such pictures clearly reveal the pertinent characteristics of the sea floor and are an important supplement to TV tape recordings.

### Prospects

The major problem in adapting television to deep-ocean exploration is the unavailability of an integrated system designed to meet specific requirements. Most systems match requirements as well as possible, but they are assembled from existing components. In many instances, the exact requirements are not fully defined. There is little doubt that as ocean endeavors become profitable,

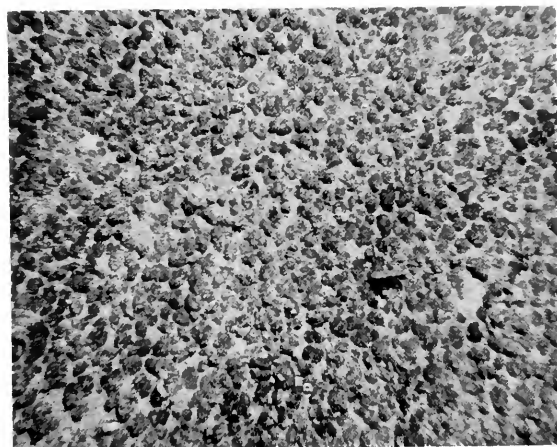

Figure 6. View of a nodule deposit taken with a 70mm camera. A thin layer of sediment covers some nodules. Equatorial eastern Pacific, 4500 meters.

economic support to meet these needs will become available. In a few years, deep-ocean surveyors will have greatly improved devices to assist them in exploring the least known sectors of our globe.

William D. Siapno is chief scientist at Deepsea Ventures, Inc., Gloucester Point, Virginia.

All photographs by B. J. Nixon, Deepsea Ventures.



MBL WHOI LIBRARY



WH 181D T

