

Oceanus

Volume 20, Number 2, Spring 1977



SOUND
IN
THE
SEA



\$2.75

Oceanus[®]

The Illustrated Magazine of Marine Science

Volume 20, Number 2, Spring 1977

William H. MacLeish, *Editor*
Paul R. Ryan, *Associate Editor*
Deborah Annan, *Editorial Assistant*

Editorial Advisory Board

Robert A. Frosch, *Associate Director for Applied Oceanography, Woods Hole Oceanographic Institution*
Edward D. Goldberg, *Professor of Chemistry, Scripps Institution of Oceanography*
Richard L. Haedrich, *Associate Scientist, Department of Biology, Woods Hole Oceanographic Institution*
John A. Knauss, *Dean of the Graduate School of Oceanography, University of Rhode Island*
Allan R. Robinson, *Gordon McKay Professor of Geophysical Fluid Dynamics, Harvard University*
David A. Ross, *Associate Scientist, Department of Geology and Geophysics, Woods Hole Oceanographic Institution*
John G. Sclater, *Associate Professor, Department of Earth and Planetary Sciences, Massachusetts Institute of Technology*
Allyn C. Vine, *Senior Scientist, Department of Geology and Geophysics, Woods Hole Oceanographic Institution*

Woods Hole Oceanographic Institution

Charles F. Adams, *Chairman, Board of Trustees*
Paul M. Fye, *President and Director*
Townsend Hornor, *President of the Associates*

Editorial correspondence: *Oceanus*, Woods Hole Oceanographic Institution, Woods Hole, Massachusetts 02543. Telephone (617) 548-1400.

Subscription correspondence: All subscription and single copy orders and change-of-address information should be addressed to *Oceanus*, 2401 Revere Beach Parkway, Everett, Mass. 02149. Urgent subscription matters should be referred to our editorial office, listed above. Please make checks payable to Woods Hole Oceanographic Institution. Subscription rates: one year, \$10; two years, \$18. Subscribers outside the U.S. or Canada please add \$2 per year handling charge; checks accompanying foreign orders must be payable in U.S. currency and drawn on a U.S. bank. Current copy price, \$2.75; forty percent discount on current copy orders of five or more. When sending change of address, please include mailing label. Claims for missing numbers will not be honored later than 3 months after publication; foreign claims, 5 months. For information on back issues, see page 76.

Postmaster: Please send Form 3579 to *Oceanus*, Woods Hole, Massachusetts 02543.

Contents

SIGHT THROUGH SOUND by Allyn C. Vine 2

A READER'S GUIDE TO UNDERWATER SOUND by Paul R. Ryan 3

A CHRONICLE OF MAN'S USE OF OCEAN ACOUSTICS by J. B. Hersey

Present understanding of ocean acoustics is based on scientific conjecture and research traceable back to the ancient Greeks. 8

ACOUSTIC NAVIGATION by Robert C. Spindel

Precision navigation requirements at sea are becoming more severe as oceanographers seek to understand the dynamics of the ocean, industrialists extend their search for natural oil and gas deposits from the relatively shallow continental shelf to the deep-sea environment, and military personnel continue their deterrence mission. 22

ACOUSTIC PROBING OF OCEAN DYNAMICS by Robert P. Porter

Oceanographers are studying the complexities of ocean eddy patterns in order to understand their influence on the ocean environment. Only acoustic systems can sample the details of a sufficiently large area of the ocean for a long period of time, thereby giving quantitative information on its energy and momentum. 30

ABSTRACT ART OR ACOUSTICS? 39

UNDERWATER ACOUSTICS IN MARINE GEOLOGY by George G. Shor, Jr.

Using multi-channel seismic reflection systems to obtain details of the ocean margins. At the same time, seismic refraction work is in danger of neglect, and is being used for deeper penetration into the

WHALES by William A. Watkins

Occurrences of sound clicks called "codas" that give investigators a clue to whale behavior. It may be that these clicks have a communicative function. 50

SOUND — AN UNDERUSED TOOL by Paul T. McElroy

The marine fisheries field depends on a broad understanding of the ocean. The acoustician and the biologist need to advance their work together in order to conserve fish resources. 59

SONAR by Robert W. Morse

Of unprecedented magnitude, the detection and tracking of underwater targets by acoustic means is of paramount importance. 67

Charles Darwin's theory of sound speed was based on two pen-and-ink drawings that appeared in Souvenirs et Memoires — 1855, 1893, Geneva. The front cover shows Daniel Colladon on Lake Geneva at the age of 17. The back cover shows the watch when he saw the flash from the boat on the back cover (about 16 kilometers away) and the striking of the bell generated the flash) about 10 seconds later through the long distance. The experiment was based on mathematical theory supplied by Charles Sturm, then 25, the speed of sound in water was recorded — 1,435 meters per second at 8 degrees Celsius, or about 3 meters less than presently accepted values. The experiment took place in September, 1826. (Courtesy R. B. Lindsay, Marvin Lasky, and The Journal of the Acoustical Society of America)

DON'T MISS



THE BOAT

Oceanus[®]

The Illustrated Magazine of Marine Science

Volume 20, Number 2, Spring 1977

William H. MacLeish, *Editor*
Paul R. Ryan, *Associate Editor*
Deborah Annan, *Editorial Assistant*

Editorial Advisory Board

Robert A. Frosch, *Associate Director for Applied Oceanography, Woods Hole Oceanographic Institution*
Edward D. Goldberg, *Professor of Chemistry, Scripps Institution of Oceanography*
Richard L. Haedrich, *Associate Scientist, Department of Biology, Woods Hole Oceanographic Institution*
John A. Knauss, *Dean of the Graduate School of Oceanography, University of Rhode Island*
Allan R. Robinson, *Gordon McKay Professor of Geophysical Fluid Dynamics, Harvard University*
David A. Ross, *Associate Scientist, Department of Geology and Geophysics, Woods Hole Oceanographic Institution*
John G. Sclater, *Associate Professor, Department of Earth and Planetary Sciences, Massachusetts Institute of Technology*
Allyn C. Vine, *Senior Scientist, Department of Geology and Geophysics, Woods Hole Oceanographic Institution*

Woods Hole Oceanographic Institution

Charles F. Adams, *Chairman, Board of Trustees*
Paul M. Fye, *President and Director*
Townsend Hornor, *President of the Associates*

Editorial correspondence: *Oceanus*, Woods Hole Oceanographic Institution, Woods Hole, Massachusetts 02543. Telephone (617) 548-1400.

Subscription correspondence: All subscription and single copy orders and change-of-address to *Oceanus*, 2401 Revere Beach Parkway, Everett, Mass. 02149. Urgent subscription correspondence referred to our editorial office, listed above. Please make checks payable to Woods Hole Oceanographic Institution. Subscription rates: one year, \$10; two years, \$18. Subscribers outside the U.S. add \$2 per year handling charge; checks accompanying foreign orders must be payable in U.S. currency and drawn on a U.S. bank. Current copy price, \$2.75; forty percent discount on current copy orders of five or more. When sending change of address, please include mailing label. Claims for missing numbers will not be honored later than 3 months after publication; foreign claims, 5 months. For information on back issues, see page 76.

Postmaster: Please send Form 3579 to *Oceanus*, Woods Hole, Massachusetts 02543.

HAS THE SUBSCRIPTION COUPON BEEN DETACHED?

If someone else has made use of the coupon attached to this card, you can still subscribe. Just send a check — \$10 for one year (four issues), \$18 for two, \$25 for three* — to this address:

Oceanus
Woods Hole Oceanographic
Institution
Woods Hole, Mass. 02543

Please make check payable to
Woods Hole Oceanographic
Institution

*Outside U.S. and Canada, rates are \$12 for one year, \$22 for two, \$31 for three. Checks for foreign orders must be payable in U.S. dollars and drawn on a U.S. bank.

Contents

SIGHT THROUGH SOUND by Allyn C. Vine 2

A READER'S GUIDE TO UNDERWATER SOUND by Paul R. Ryan 3

A CHRONICLE OF MAN'S USE OF OCEAN ACOUSTICS by J. B. Hersey

Present understanding of ocean acoustics is based on scientific conjecture and research traceable back to the ancient Greeks. 8

ACOUSTIC NAVIGATION by Robert C. Spindel

Precision navigation requirements at sea are becoming more severe as oceanographers seek to understand the dynamics of the ocean, industrialists extend their search for natural oil and gas deposits from the relatively shallow continental shelf to the deep-sea environment, and military personnel continue their deterrence mission. 22

ACOUSTIC PROBING OF OCEAN DYNAMICS by Robert P. Porter

Oceanographers are studying the complexities of ocean eddy patterns in order to understand their influence on the ocean environment. Only acoustic systems can sample the details of a sufficiently large area of the ocean for a long period of time, thereby giving quantitative information on its energy and momentum. 30

ABSTRACT ART OR ACOUSTICS? 39

UNDERWATER ACOUSTICS IN MARINE GEOLOGY by George G. Shor, Jr.

More and more marine geologists are using multi-channel seismic reflection systems to obtain details of structure in the complex areas along the ocean margins. At the same time, seismic refraction work is becoming more common, after a period of neglect, and is being used for deeper penetration into the mantle. 40

ACOUSTIC BEHAVIOR OF SPERM WHALES by William A. Watkins

Sperm whales produce repetitive sequences of sound clicks called "codas" that give investigators information about behavior patterns. It may be that these clicks have a communicative function. 50

ACOUSTICS IN MARINE FISHERIES — AN UNDERUSED TOOL by Paul T. McElroy

The significance of acoustic data in the marine fisheries field depends on a broad understanding of the behavior and physiology of fish. The acoustician and the biologist need to advance their work together in order to develop accurate evaluations of fish resources. 59

ACOUSTICS AND SUBMARINE WARFARE by Robert W. Morse

Given peacetime undersea forces of unprecedented magnitude, the detection and tracking of missile-carrying submarines by acoustic means is of paramount importance. 67

The front and back covers were adapted by Nancy Barnes from two pen-and-ink drawings that appeared in Souvenirs et Memoires — Autobiographie de Jean-Daniel Colladon, p. 135, 1893, Geneva. The front cover shows Daniel Colladon on Lake Geneva at the age of 24 with a stop-watch in his hand. He started the watch when he saw the flash from the boat on the back cover (about 16 kilometers away) and stopped it when he heard the signal (the striking of the bell generated the flash) about 10 seconds later through the long trumpet. With this crude apparatus and with mathematical theory supplied by Charles Sturm, then 25, the speed of sound in water was recorded — 1,435 meters per second at 8 degrees Celsius, or about 3 meters less than presently accepted values. The experiment took place in September, 1826. (Courtesy R. B. Lindsay, Marvin Lasky, and The Journal of the Acoustical Society of America)

Copyright © 1977 by Woods Hole Oceanographic Institution. Published quarterly by Woods Hole Oceanographic Institution, Woods Hole, Massachusetts 02543. Second-class postage paid at Woods Hole, Massachusetts, and additional mailing points.

SIGHT THROUGH SOUND

We use sight and sound to investigate and appreciate the world around us. Astronomers looking upward into the heavens rely principally on sight; oceanographers looking down into the ocean and the earth below it rely principally on sound. Through the logic, and magic, of electronics it has become possible in both fields to transform many of the sights we cannot see and sounds we cannot hear into numbers, graphs, and pictures that help us sense and understand.

An earlier issue of *Oceanus* (Spring 1975) presented some important aspects of deep-sea photography, visual techniques that have proved useful at relatively short range. This issue concerns acoustical techniques operating over much longer distances; for example, techniques that permit tracking current-measuring floats for many months at ranges up to 1,000 kilometers. There is not space here to look at the non-oceanographic applications of underwater acoustical technology (such as the very high-frequency active sonar that doctors use to analyze conditions within the body and brain). There is barely enough to touch upon the history and most active research areas of sound in the sea.

Predicting in science is apt to be foolish, and even extrapolating trends can be dangerous. Yet the techniques and principles of sound continue to appear ever more promising in oceanographic research. For example, in deep-water echo sounding from surface ships, the width of the sound beam

usually has been 10 degrees or more, illuminating a section of the ocean bottom some 500 to 1,000 meters across. Scanning echo-sounding gear with ten times that resolving power is now coming into use, and it would appear that another similar leap in resolution is possible. If so, objects on the bottom between the size of a car and a small house may someday be observable from the surface.

Acoustic beacons fixed to the bottom can serve as submerged street signs to mark shipping lanes, and turn off points for specific harbors. If such a beacon were attached to a ship and the ship sank, the beacon could be made to say "here I am" for many years. Thus, such a device would not only be useful for investigation and salvage of the wreck, but also might help orient the immediate search for survivors.

Meanwhile, acoustical methods for the study of currents, waves, eddies, and other physical phenomena of the sea are becoming increasingly more important for the oceanographer. In another area, the three-dimensional, high-resolution systems used by marine geologists are extending down into lower frequency ranges. Major improvements in this direction may permit much better measurements of distorted sub-seabed geological structures.

And so in his study of the sea — though hearing cannot ever fully replace sight, the oceanographer would be very blind indeed without sound.

Allyn C. Vine

A READER'S GUIDE TO UNDERWATER SOUND

BY PAUL R. RYAN

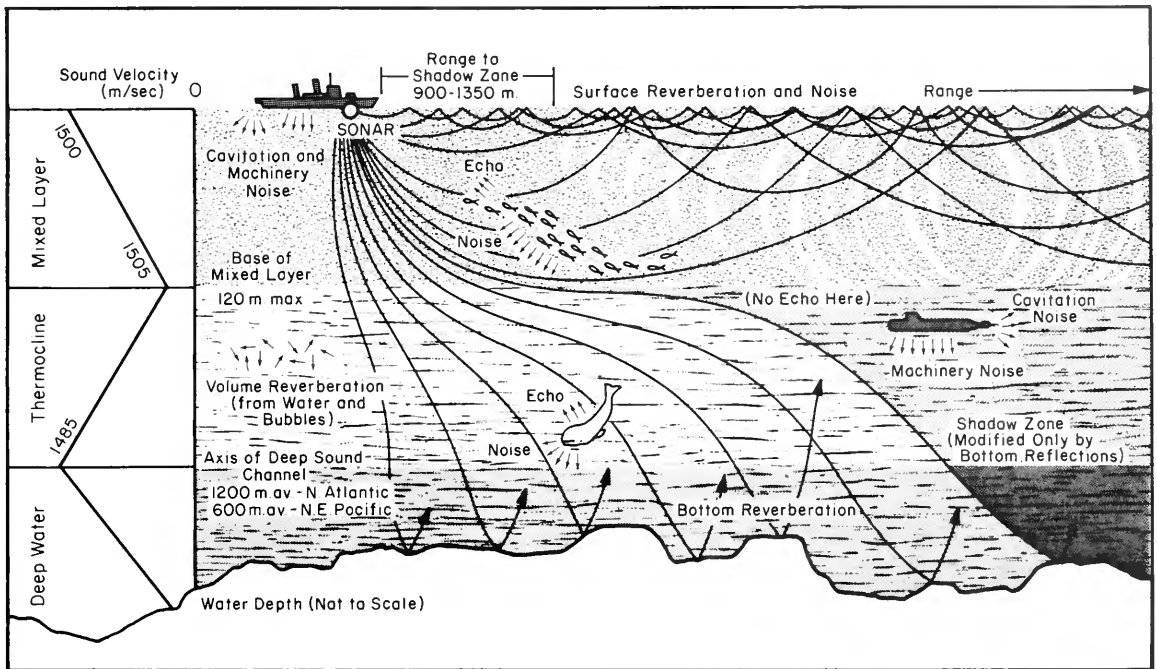

Figure 1. A simplified sketch of a ship sonar system. The illustration also shows how sound rays bend when they travel through layers of changing sound velocity. In the mixed layer, the rays tend to bend upwards, concentrating high-intensity sound over long ranges. In the thermocline, they tend to bend downward and spread due to the lower temperature and the reduced sound intensity. Where the rays tend to split at the base of the mixed layer is what is known as the "shadow zone," an area where very little sound penetrates. (Adapted from *Underwater Sound* by R. A. Frosch in *International Science and Technology*)

Sound is one of the best tools oceanographers have for working in the sea. It offers them the ability to listen to underwater life, measure distances, communicate, map the bottom terrain, navigate, and generally explore the ocean environment. At the same time, it enables the military to carry out a number of activities, including the tracking of nuclear submarines equipped with long-range ballistic missiles. Underwater sound also has its commercial applications in the exploration for oil and minerals, for dredging, for fish finding, for the positioning of ships and docking, and for various recreational activities.

The speed or *velocity* of sound in seawater at different depths is the prime concern of the acoustician. He uses it to calibrate all distance measurements by sound, and to determine sound

paths in the ocean. If the velocity of sound in seawater was the same everywhere, sound rays would travel in straight lines. However, this is not normally the case. The velocity of sound is different at different depths due to changes in *temperature*, *salinity*, and *pressure*. Gas bubbles and particles of sediment may also affect the speed of sound, but these effects are generally small and rare, except near the surface or bottom. Any particular sound ray tends to be bent toward the water of lowest temperature, salinity, or pressure, depending on which is predominant. Likewise, it tends to turn away from the water of the highest temperature, salinity, or pressure.

We can see then that the speed and the path of sound, from the surface downward, are affected by two different influences. Sound goes faster with

greater depths and pressures, but lower temperatures tend to counteract the increased velocity. In most areas of the ocean, the temperature of seawater near the surface (to a depth of about 120 meters) results from the interplay of sun, wind, and waves on top. The temperature in this range, which is called the *mixed layer* or the *isothermal layer*, is different depending on the weather, season, and location. At times the upper layer is well-mixed and temperatures within it are constant. At other times, there is no mixed upper layer. In arctic climates in winter, for example, the entire water column may be isothermal, or nearly the same temperature.

Below the mixed layer is the *thermocline*, extending to an average depth of about 1,200 meters in the North Atlantic to 600 meters in the Northeast Pacific. In this zone, temperature decreases so rapidly as to more than offset the effects of increasing pressure. Thus, the speed of sound in this zone decreases until it reaches a *minimum velocity* or *value*, usually somewhat shallower than the bottom of the thermocline. Below this point, the temperature becomes fairly constant, but the pressure continues to increase with depth and, correspondingly, so does the speed of sound (Figure 1).

Perhaps the most important consequence of this *vertical* velocity profile is that in deep water it causes the ocean to act like a large, crude lens. Sound rays from a deep *source* near the bottom of the thermocline that radiate *horizontally*, or within a few degrees thereof, are bent sufficiently so that they curve and recurve within the ocean, sometimes being detectable for many thousands of kilometers. These paths are the most useful for long-distance measurements, or communications, and constitute a permanent, nearly ubiquitous *deep sound channel* in the ocean. Radiation at higher angles, say more than 15 to 20 degrees to the horizontal, propagates both to the surface and the ocean floor. It turns out that sound striking the surface is nearly all reflected downward to strike the bottom. Most of the sound that strikes the bottom, especially at high angles, passes into the bottom, where some is *reflected* from various layers of sediment and rock. This reflected sound energy returns to the surface. It reflects downward again and may be detectable after two or more round trips between the surface and the ocean floor. This energy is used by scientists and oil prospectors to study sediments and rock beneath the ocean.

There are other interesting modes of sound propagation: for example, when sound waves are sent outward and downward from a ship in warm surface water, the rays in the mixed layer tend to

bend or be *refracted* upward due to the pressure effect. Some, however, propagate into the thermocline, where they tend to turn downward because of the temperature effect. The area behind where this split occurs has been termed the "shadow zone." It was in this zone that World War II submarines tried to hide from a ship's *sonar* system, because very little sound penetrated this area to any distance.

Defense Needs Spur Use of Acoustics

The need to detect and track submarines and surface vessels during wartime led to the development of sonar, an acronym for SOund Navigation And Ranging. Sonar systems are either *passive* or *active*. Passive sonar systems listen to sound generated and radiated by the *target*, utilizing only one-way transmission through the sea. An active system, which operates on the same principle as radar, is one in which sound is purposefully generated by a source that is called the *projector*. The sound waves generated by this projector are transmitted through the water to a target, where they are *reflected* back as *echoes* to a *hydrophone*, which converts sound into electricity. The hydrophone is the water equivalent of the microphone in air.

Both the projector and the hydrophone are forms of *transducers*. The projector converts mechanical, chemical, or electrical energy into acoustic energy, while hydrophones convert acoustic energy to electrical energy. In general, there are three types of transducers — those that transmit sound, those that receive sound, and those that do both.

The sound-producing projectors can be designed to produce an omnidirectional sound field or a directional field. They may be used to generate continuous signals or pulsed signals and they may be used to generate signals of a few milliwatts or several megawatts.

How Sound Waves Propagate

A simple example of how sound waves propagate* or spread through the ocean can be visualized when one thinks of a pebble dropped into a still pond. Ripples move away in concentric circles about the drop point. If instead of dropping a pebble, a repetitive motion is created, a steady flow of ripples can be maintained. The number of ripples that pass

*Gases, liquids, and solids consist of molecules (atoms) that are closely (but not rigidly) packed, with forces acting between the molecules. The motion of one molecule influences its neighbor, which influence their neighbors, and so on. It is by this effect that sound is propagated.

an observer in 1 second is known as the *frequency* of the wave. Frequency is measured in cycles per second. One cycle per second is called 1 Hertz, after a well-known 19th century physicist. One half of the height between the crest of a sound wave and its trough is known as the wave *amplitude* and can be plotted on a simple graph (Figure 2). The distance between two adjacent crests is denoted as the *wavelength*. The speed with which wave crests pass an observer is the wave *velocity*. If the repetition period is increased, the frequency of the wave increases and its wavelength decreases.

Wavelength and frequency play a vital role in use of sound in the sea. Since these two quantities are inversely proportional it is only necessary to specify one in order to determine the other. High-frequency sound, those waves with small wavelengths, are greatly attenuated or weakened by seawater. Low-frequency waves experience little attenuation. Thus, a tone of 440 Hertz (equivalent to the concert pitch A440) can be transmitted many hundreds of kilometers in the ocean, whereas a tone of 20,000 Hz, which is near the upper limit of human hearing, can be transmitted only several kilometers. Using present day loud acoustic sources and receivers in seawater, typical working ranges for one-way transmission under appropriate conditions are:

Frequency	Wavelength	Distance
100 Hz	15 meters	Thousands of kilometers
1,000 Hz	1.5 meters	Hundreds of kilometers
10,000 Hz	15 centimeters	Tens of kilometers
100,000 Hz	1.5 centimeters	One kilometer
1,000,000 Hz	1.5 millimeters	Tens of meters

These permissible ranges have broad implications. If the aim is to communicate through the ocean via underwater sound, then it is more practical to use high-frequency sound waves, since a higher frequency signal can be made to carry more information in a given length of time. However, very high frequencies cannot be transmitted long distances. Similarly, if the need is to accurately map the ocean floor or to provide details of submerged structures, or to locate the precise position of underwater objects, then it is preferable to use sound waves with short wavelengths. Because these short wavelengths correspond to waves of high frequency, it is not practical to obtain very high *resolution* (the ability to distinguish between target details) at very long ranges. Thus, the acoustician must select sound frequencies that yield the best compromise between desired resolution and desired range.

The relative *intensity* of detected sound is most commonly expressed in units called *decibels*

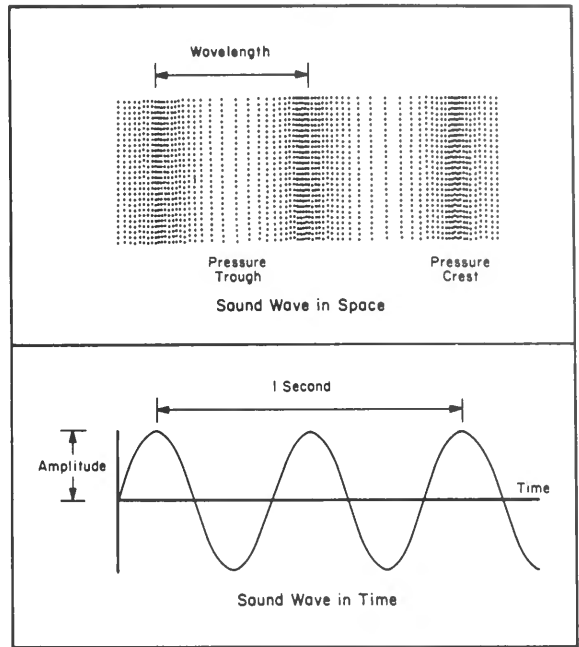

Figure 2. Two views of a sound wave. The upper portion of the figure shows the alternate compressions and rarefactions of molecules in the conducting medium. The lower portion schematically shows how a stationary observer sees a sound wave pass by. Since there are two complete cycles in one second, the wave has a frequency of 2 cycles per second (2 Hertz).

(dB) that were first used by scientists and engineers in the development of the telephone. Decibels provide a convenient measure for comparing *sound levels* over a wide range of intensities with a practical scale condensed in a logarithmic fashion. Thus, a 10 decibel change is a factor of 10 and a 20 decibel change a factor of 100 in sound intensity. Most measurements are referenced to a standard sound level of one *micropascal*, having a pressure level of 10^{-5} dynes (dyn) per square centimeter. The intensity versus the pressure level is plotted in Figure 3.

Just as the word *phase* describes a particular portion of the lunar cycle, the term is also used to denote a particular portion of the sound wave. A complete wave cycle, from one crest to another, is divided into 360 equal increments of 1 degree each. By specifying the phase of the wave, or the relative phase between two waves, one can describe what point of the wave is being discussed, or how two waves appear in relation to each other. Phase is an important concept because it indicates how two combining waves will add. For example, if the high pressure portion of one wave coincides in time with the low pressure portion of the other, and if the two waves have equal amplitudes and are thus

180 degrees out of phase, they will cancel each other, resulting in no sound signal at all (Figure 4). If the waves were in phase, the resultant signal would be twice as large as either of the constituent waves.

The Deep Sound Channel

One might well ask: How far can sound be detected underwater? The sounds from depth charges fired by the Lamont-Doherty Geological Observatory's research vessel *Vema* and the Australian naval ship *HMAS Diamantina* in 1960 off Australia were picked up near Bermuda at a distance of 19,000 kilometers, or half-way around the world. The depth charges were exploded near the bottom of the thermocline zone discussed earlier, which is also known as the *deep sound channel* that is centered at depths between 600 and 1,200 meters. This is the region where sound velocities decrease to a minimum value with depth and then increase in value as a result of pressure. About a tenth of the sound waves generated within this layer cannot escape, because they are refracted back by the waters above and below as though they were in a speaking tube (Figure 5).

By triangulation fixing from several listening stations that are part of a system known as *SOFAR* (Sound Fixing And Ranging), sound sources in this channel can be located to within about a kilometer.

Let us now imagine a sonar system serving a practical purpose, such as detection, classification (determining the nature of a target), torpedo homing, communication, or fish finding. In each of these pursuits, the acoustician has to take into account the background noise that interferes with the signal. In general, background noise can be broken down into two categories: *ambient noise* and *self-noise*.

Ambient noise refers to the ever-present background of environmental and distant shipping noise. It includes wave and surf noise, rain, seismic and

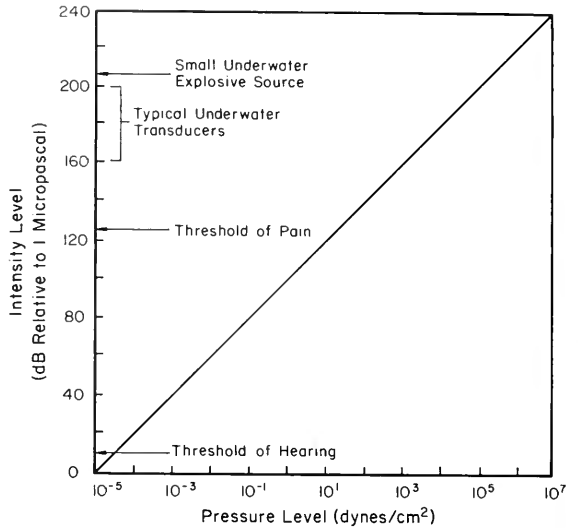

Figure 3. The logarithmic decibel scale for sound intensity, showing pressure levels from 10^{-5} to 10^{+7} dynes per square centimeter, corresponding to 0 to 240 decibels re 1 micropascal.

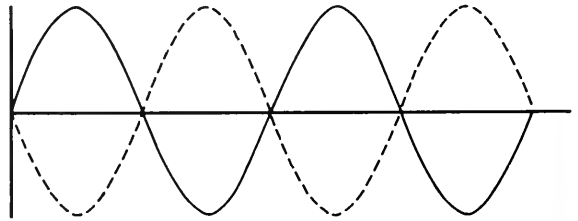

Figure 4. Two acoustic waves 180 degrees out of phase.

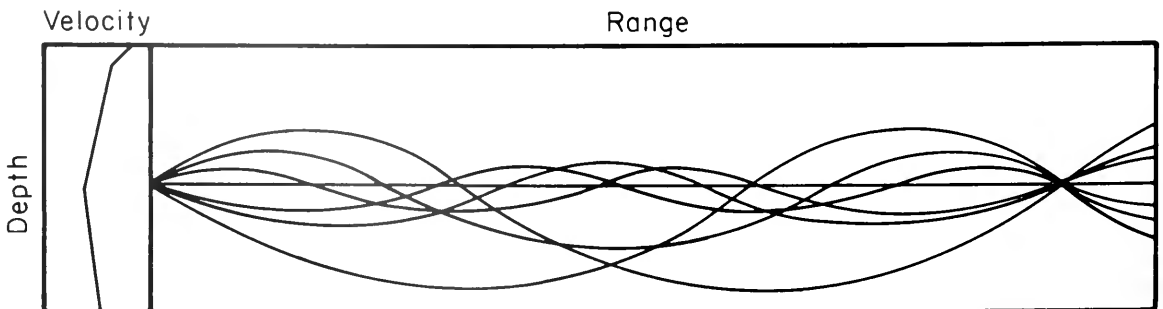

Figure 5. A typical sound-ray diagram, showing the way sound travels in the *SOFAR* channel.

volcanic disturbances, plus the sounds emitted by fish and marine animals. Self-noise is produced by the presence of the listening device itself and includes such sources as *cavitation noise* and *machinery noise* from one's own propellers and engines, cable strumming, splashes of waves against the hydrophone, and sometimes even crabs crawling on a hydrophone.

The ambient background of the sea often presents difficult measurement problems. For a valid measurement of ambient noise, all possible sources of self-noise must be reduced to an insignificant contribution to the total noise level. Noise caused by nearby ships, surface waves, and earth seismicity occurs at below 50 Hz, distant shipping and rough sea sounds at 50 to 500 Hz, and molecular thermal motions of the sea at 500 Hz to hundreds of kHz.

Further complicating the acoustician's task is the fact that acoustic energy bounces off schools of fish, or pinnacles and sea mounts on the seabed, thereby *scattering* a portion of the sound waves. The sum total of the scattering in a sonar scan is called the *reverberation*. Since it often forms the primary limitation on the performance of an active sonar system, it is essential to be able to compute the reverberation level that will be encountered by the system in order to estimate the system's performance against the desired quarry — a school of fish, a submarine in wartime, or an oil-bearing layer of rock during an energy shortage.

This brief guide is by no means a complete background to the subject of underwater sound. It is meant to serve as a general map to help the reader through the remainder of this issue. More complete descriptions and examples of the physics of underwater sound can be found in the suggested readings.

Acknowledgement

This article was scheduled to be written by Earl E. Hays, Chairman of the Ocean Engineering Department at Woods Hole Oceanographic Institution, but he was called to sea duty while working on the initial draft. The author finished this considerably altered version with guidance from Robert A. Frosch, Robert W. Morse, Robert C. Spindel, and Allyn C. Vine, all from the Woods Hole Oceanographic Institution. In addition, a further note of appreciation is due J. B. Hersey, U.S. Navy Deputy Assistant Oceanographer for Ocean Science, who also reviewed this article.

Suggested Readings

- Albers, V. M. 1969. *Underwater acoustics instrumentation*. Pittsburgh, Pa.: Instrument Society of America.
- Frosch, R. A. 1962. Underwater sound. *International Science and Technology*. 9:40-46.
- Hunt, F. V. 1954. *Electroacoustics*. Cambridge, Mass.: Harvard University Press.
- National Academy of Sciences. 1970. *Present and future uses of underwater sound*. Committee on Underwater Telecommunication/National Research Council. Washington, D.C.: Natl. Acad. of Sci.
- Ross, D. A. 1977. *Introduction to oceanography*. N.J.: Prentice Hall, Inc.
- Strutt, J. W. (Lord Rayleigh). 1945. *The theory of sound*. Vols. I and II. N.Y.: Dover Publications.
- Urick, R. J. 1975. *Principles of underwater sound*. N.Y.: McGraw-Hill, Inc.

A CHRONICLE OF MAN'S USE OF OCEAN ACOUSTICS

By J. B. Hersey

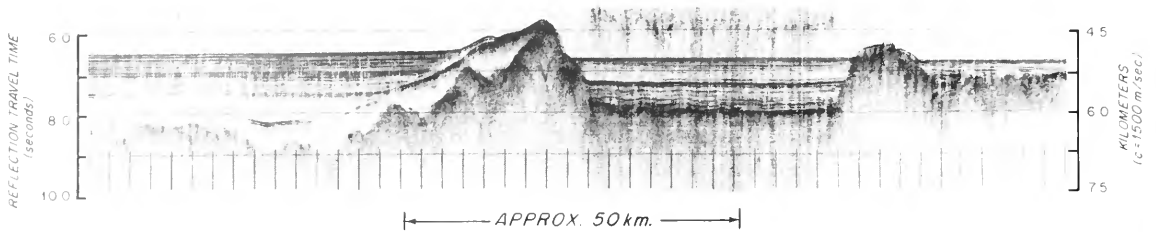

*A 1976 deep-sea Continuous Seismic Profiler record from the Somali Basin region of the Indian Ocean (R/V Atlantis II 93-7). The ridge, one of at least three extending south en echelon with Chain Ridge, is in part the southeast boundary of the thick sediment deposits of the northernmost part of the Basin. One horizon, conformable with the west side of the ridge, suggests that sediments collected on the basement were then uplifted along this structure. (After Bunce and Molnar, submitted to *Journal of Geophysical Research, Seismic profiling and basement topography in the Somali Basin: possible fracture zones between Madagascar and Africa*, 1977)*

To most people, the authentic lore of sound in the ocean — or anywhere in water — is a remote and probably fringe interest of mankind. Nevertheless, hundreds of millions of dollars are spent each year on the use of ocean acoustics by the minerals industry (oil and hard mineral exploration in the ocean), the food industry (fishing), the transportation and recreation industries (navigation and safety devices), and the navies of the world (undersea warfare). Much smaller investments of large future potential are also made in manufacturing special devices, such as those used in acoustic control, advanced ocean floor inspection and mapping, and in search and recovery missions. All of these and more will affect the future of man in the ocean in a major way. For example, this obscure technical field is pivotal to the day-to-day operation of the offshore oil industry. Hence, it is helpful to solve today's energy problems. It also is critical to national defense at sea, important to ocean transport and recreation as a safety support, and at least useful to the seafood industry.

Ocean acoustics concerns the generation and propagation of elastic waves of whatever kind and wavelength in and/or beneath the oceans. Seismology also makes a similar territorial claim for the earth as a whole. Thus, ocean acoustics can be regarded as a sub-set of seismology as well as of acoustics. Nevertheless, ocean acoustics is nearly but not quite clearly separable from world-scale

seismology, and in another way not separable from acoustics. I shall try to describe the fuzzy boundary that tends to set them off from each other. Seismologists have focused their interest on diagnosing what happens in an earthquake, or a "nuclear event," and *how* the resulting compressional and shear vibrations propagate through the earth. The *HOW* is used to conjecture how the earth is put together; what it is made of. Ocean acousticians emphasize the propagation of compressional waves. They and the various oceanographers (physical, biological, geological, and so on) are beginning to seek hints from acoustics about similar questions of structure and process in the oceans. Both specialties deal with very broad vibration spectra. Earthquake seismologists study complex seismograms, which contain vibratory energy in frequencies from small fractions of a cycle per minute to hundreds of cycles per second. Ocean acousticians have long since burst the bounds of man's auditory sense (roughly 32 Hertz [Hz] to 15 to 20 kilohertz [kHz]), and are using or studying processes at 1 Hz to more than 300 kHz.

The obvious overlap, from 1 to 1,000 Hz, includes many important applications in both fields. Distinctions can be drawn. The compressional waves of sound displace the medium in the direction of propagation. The seismologist is concerned with at least three types of lateral displacements that

propagate as waves in solids because of their tensile strength. Combinations of these with compressional waves occur as well. But nearly all the seismologists' types of waves may convert to sound waves when they enter the ocean from beneath the bottom — and vice versa. Hence, energy conversion is an important cause of the loss of sound energy, and a source of noise in the ocean. Thus for a more complete understanding, the acoustician needs the seismologist — and, again, vice versa. These facts have long been appreciated by a few; recently this appreciation has become much more general. (Thank goodness!)

Some Early Observations

While theories about sound in the air and the vibrations of the earth have been fundamental to man's store of knowledge for thousands of years, ocean acoustics was for many centuries little more than a curiosity. Some of the earliest conjectures about the fundamental nature of sound in the ocean come down to us from Aristotle.

Aristotle may have been one of the first to note that sound could be heard in the water as well as in air. Nearly 2,000 years later, Leonardo da Vinci (1452-1519) observed: "If you cause your ship to stop and place the head of a long tube in the water and place the other extremity to your ear, you will hear ships at great distances." Presumably the background noise of lakes and seas was much lower in his day than now, when ships of all kinds pollute the undersea with continual din.

About a hundred years later, Francis Bacon in *Natural History* supported the notion that water is the principal medium by which sounds originating therein reach a human observer standing nearby.

In the late 18th and early 19th century, a few gentlemen scientists interested themselves in sound transmitted in water. They measured the speed of sound in fresh and salt water, comparing these with the speed of sound through air already well measured by then. They also judged the comparative clarity and intensity of transmissions in air, water, and probably other substances. Their sound sources included bells, gunpowder, hunting horns, and the human voice. Their own ears usually served as the receivers. Accounts of a few of these gentlemen and their experiments will provide an accurate flavor.

In 1743, Abbe J. A. Nollet conducted a series of experiments to settle a dispute as to whether or not water was compressible. With his head underwater, he heard a pistol shot, a bell, a whistle, and loud shouts. He noted that the intensity

of sound decreased little with depth, indicating the loss occurred mostly at the surface. He also discovered that an alarm clock sounding in water could not be heard in air but was very loud to an observer underwater.

In 1780 and later, Alexander Monro II tested his ability to hear sounds underwater. He used a large and small bell, which he sounded both in air and in water. They could be heard in water, but the pitch sounded lower than in air. He also attempted to compare the speed of sound in air with that in water. His source was a charge of gunpowder that filled a 4-foot-long tube thrust into a pint bottle containing an explosive charge. (Does this sound faintly dangerous to anyone?) The bottle was submerged at one end of a lake. He lay in the water 800 feet away with his ears underwater to hear the explosion, but with his eyes above the surface. By conducting this experiment at night, he was able to see the flash from the gunpowder and shortly thereafter hear the sound from the explosion. Next, he completely submerged himself and used two additional explosions to distinguish between speed of propagation in air and in water. The resulting sounds were not resolvable. He concluded that the two sound speeds seemed about the same! He recognized, however, the inadequacy of this experiment and suggested another — that of striking a bell underwater while simultaneously firing a musket in the air. I know of no results from that experiment or whether, in fact, it was ever performed. The beginnings of understanding the dynamics of sound in water were formed during this century-long period, and one gains the impression that these gentlemen must have thoroughly enjoyed what they were doing. Probably it was all fun, though frequently frustrating.

In 1826, Daniel Colladon, a Swiss physicist, and Charles Sturm, a French mathematician, made the first widely-known measurement of the speed of sound in water in Lake Geneva. The value was 1,435 meters per second at a temperature of 8 degrees Celsius. They also reported measurements in seawater near Marseilles about 1820 by François Sulpice Beudant, a French physicist, which averaged 1,500 meters per second. A bell was the sound source in both experiments. A visual signal indicated the striking of the bell to distant observers listening underwater and timing the interval between visual signal and received sound (see Cover and Table of Contents).

Between 1830 and 1855, an increasing number of scientists were employed in underwater activities. They doubtless enjoyed their work as well as the gentlemen scientists before them, but they

began to think of the practical or applied implications of sound underwater. They began to ask questions, such as: What is the use of it? Can divers communicate by voice underwater or by voice with men on land? Can the echo of the sound pulse be used to measure ocean depths, distances to ships? Can communications between ships be improved by underwater transmission of the sound?

In 1830, the U.S. Navy's Depot of Charts and Instruments was created to improve the art of navigation, and was further developed through the leadership of Lieutenants Louis Goldsborough and Charles Wilkes. It made important early contributions to exploration. An expedition under Lieutenant Wilkes, for example, helped to determine that Antarctica is a continent rather than a floating ice cap. In 1842, Lieutenant Matthew Fontaine Maury assumed command of the Depot, which under his leadership developed a strong program of inquiry into surface currents and depths of the ocean. He was anxious to improve the Navy's ability to "sound" the ocean. A vigorous development program was pursued to achieve a reliable method not only of measuring the depth in "blue water" but also of sampling the bottom.

Chapter 12 of Maury's *Physical Geography of the Sea*, sixth edition, 1859, gives an account of frustration and hope thwarted. Paragraph 678 (page 243) tells of the part acoustics played: "Attempts to fathom the ocean, both by sound and pressure, had been made, but out in 'blue water' every trial was only a failure repeated. The most ingenious and beautiful contrivances for deep-sea soundings were resorted to. By exploding petards, or ringing bells in the deep sea, when the winds were hushed and all was still, the echo or reverberation from the bottom might, it was held, be heard, and the depth determined from the rate at which sound travels through water. But, though the concussion took place many feet below the surface, echo was silent, and no answer was received from the bottom. . . ." This account does not mention the method of listening to the echo, but the suggestion is strong that men on deck listened unaided in air. Had they used Leonardo's long tube or some other sensible coupling device, the first practical application of underwater sound might have been developed a half century sooner.

As the world changed from sail to engine-driven craft, there was mounting concern about the safety of navigation in fog and the danger of collision with other ships or icebergs, or grounding in shoal water. In separate investigations, sound in air was found unreliable by John Tyndall, a British physicist, and Joseph Henry, an American

physicist, and the use of underwater sound was suggested. Traditional and available fog horns, however, prevented any change. Alexander Graham Bell in 1885 sponsored a proposal by Frank Della Tone to detect icebergs by means of sonic echoes in air. Bell and Henry Augustus Rowland, a physicist at Johns Hopkins University, made such experiments successfully on ships instead of icebergs in the Patapsco River near Chesapeake Bay. The possible advantages of signaling by sound in water were taken up again in the late 1880s. Lucian Blake made a number of experiments on propagation in the Taunton River in Massachusetts and later in the Wabash River in Indiana, which seemed encouraging. Thomas Alva Edison invented an underwater means of communicating between ships. But for some unknown reason government interest in this work died out, following a complete report of the work of Blake, Edison, and others compiled by the U.S. Light House Board in 1889.

A year before, in 1888, A.M. Banare had published *Les Collisions en mer* in which he fully discussed the status of underwater sound techniques. He explained the development of a hydrophone and described a method for locating a sound source, using the acoustic shadow of a ship. He also gave a rather detailed account of Blake's experiments and mentioned the ideas of Edison.

In 1889, Professor Richard Threlfall and John Frederick Adair of the University of Sydney, working in the harbor of Port Jackson (the harbor of Sydney, Australia), found that the speed of sound from an explosion was directly related to the size of the explosive charge. All their results were in the ranges 1.73 to 2.01 kilometers per second, well above modern seawater measurements. Their results indicate they were receiving energy propagated beneath the sea floor.

Subsequently, the effects of temperature, pressure, and dissolved salts were gradually sorted out, but most of this work was not completed until well into the 20th century.

One of the earliest uses of sound waves in the sea was the installation of submerged bells on lightships. The noise from these bells could be detected at a considerable distance through a stethoscope or simple microphone mounted in the hull of a ship. When the ship was outfitted with two detecting devices on opposite sides of the hull, it became possible to determine the approximate bearing of the lightship by transmitting the sounds separately to the right and left ears of an observer outfitted with stereo earphones. By timing the interval between the sound of the bell and the sound of a simultaneously sent blast of a foghorn, a ship

could determine its distance from the lightship, the distance being about two-thirds of a mile per second time difference.

In 1899, Elisha Gray and Arthur J. Mundy were granted a patent for an electrically operated bell for underwater signaling. Like Blake, Gray and Mundy started with bell and microphone. Mundy hoped to install the microphone on ships, but found their internal engine noise interfered with the weak signal from the bell. There were other problems to be solved, too. The work of Gray and Mundy led in 1901 to the establishment of the Submarine Signal Company, which was formed by a group of scientists who were convinced that sound in water could provide the most reliable means for the safe navigation of ships. The underwater bell was intensively developed by this company and used by the U.S. Light House Service until 1906.

In 1907, A. F. Fells was granted a patent for echo sounding. The principle was to measure the time interval between the initiation of the sound pulse and the reception of its echo from the sea floor. Samuel Spitz, around 1911, attempted to measure ocean depths with apparatus that first recorded the signal and its echo on a magnetic tape and then amplified the reproduced sound. Alexander Behm (1911) is given credit for many of the first echo soundings. He fired cartridges into the water and photographically recorded signal and echo.

In 1912, R. A. Fessenden designed and built a moving coil transducer for the projection and reception of underwater sound. The Fessenden oscillator, which was designed somewhat like a specialized loudspeaker, allowed vessels to both communicate with one another by Morse Code and to detect the echoes from underwater objects. By 1914, this process, known as echo ranging, was well enough along to locate an iceberg at a distance of 3.2 kilometers. Operating on frequencies of 500 and 1,000 Hz, this underwater sound source was installed on all U.S. submarines during World War I.

Prior to World War I, the study of underwater sound suffered from lack of flexible and sensitive receivers. (The submerged human ear had about had it.) The piezoelectric effect had almost surfaced several times in the 19th century, including a conjecture by Lord Kelvin, the English physicist, that the effect probably existed. Piezoelectricity was discovered by Jacques and Pierre Curie in 1880. In principle, piezoelectric crystals could both sense and generate sound. Practical use of the effect was not made until the time of Paul Langevin (1917), the distinguished French physicist. He was the first to make the quartz receiver.



Reginald Fessenden



The Fessenden oscillator, circa 1913.

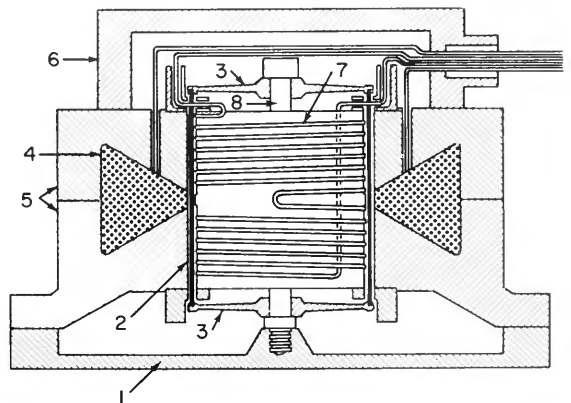

A cross section of the working parts of the Fessenden oscillator: 1) the diaphragm (60 centimeters in diameter), 2) movable copper-tube conductor, 3) flexible discs, 4) the coil, 5) the electromagnet, 6) iron core, 7) turns of wire, and 8) steel rod. (Courtesy Raytheon, Submarine Signal Division)

In 1914, Germany undertook unrestricted submarine warfare. Coincidentally, a Russian electrical engineer, Constantin Chilowsky, was convalescing in Switzerland and had plenty of time to think about the submarine problem. He conceived the idea of detecting submarines by echo ranging with high-frequency sound waves. He succeeded in getting the attention of a Dr. Milhaud, a professor of political economy at Geneva University, who agreed to forward the idea to Langevin. Thus began a brief but scientifically successful collaboration.

Chilowsky proposed a moving armature magnetic transducer as sound source in which the diaphragm was to be finely laminated to reduce eddy current losses. Langevin was not sympathetic with this idea. After considering both magnetostriction* and piezoelectricity, Langevin decided to use the "singing condenser." They had considerable trouble in securing a suitable receiver for the high-frequency sound waves; a modified carbon microphone was finally selected. Langevin and Chilowsky applied for a joint patent on the principle of their method and on the equipment. They had been able to signal underwater for a distance of 3 kilometers and to detect echoes by reflection from a large iron plate at a distance of 100 meters. Chilowsky, shortly after this, left the experimental project and Langevin continued the work alone. (It was not an altogether happy relationship.)

News of the success of Langevin's experiments reached the British government through their scientific liaison officer. One of their leading scientists, Robert W. Boyle, was instructed to organize a research group to study this problem of ultrasonics. By the middle of 1916, the British were keeping pace with the French.

Early in 1917, Langevin obtained some high-frequency amplifiers and persuaded an optician to cut some slices from a 10-inch quartz crystal that he had in his Paris shop. For his first quartz receiver, Langevin embedded one of these crystals in wax, with a foil electrode on the back and a protective sheet of mica on the front surface in contact with the water. Fine experimental results were obtained. Langevin was now encouraged to design the steel-quartz-steel transducer, which he completed in the early part of 1918. The range for one-way transmission was increased to more than 8 kilometers, and clear echoes were heard from submarines.

**Magnetostriction is the phenomenon wherein ferromagnetic materials experience an elastic strain when subjected to an external magnetic field. It also can be the converse phenomenon in which mechanical stresses cause a change in the magnetic induction of a ferromagnetic material.*

A slab of the quartz was sent to Boyle in England. Since his experiments with the quartz receiver were as successful as Langevin's, he immediately began to hunt for a supply of quartz. He found a French manufacturer of crystal spectacle lenses and chandelier pendants who was delighted to sell his supply of quartz crystals. These crystals supplied a number of the warships of the British fleet with piezoelectric material for echo-ranging equipment.

U.S. Scientists Mobilized

It soon became apparent that the United States was going to be involved in the war in which antisubmarine weapons were to play a large role. In 1915, the U.S. Navy Department organized the Naval Consulting Board, which had a mandate to mobilize the scientific resources of the country. An experimental station was established on a private estate at Nahant, Massachusetts. Here Submarine Signal Company (now part of Raytheon), General Electric Company, and American Telephone and Telegraph Company scientists and engineers devoted their energies to developing special devices based on acoustical and electrical devices already known. This station was so successful that the Navy Department decided to establish an experimental station at New London, Connecticut, to study all naval problems connected with submarines. The first problem undertaken there was to examine the nature of sounds produced by ships and to determine the distances at which they could be heard. A few years previously, the vacuum tube had been invented. When an amplifier using this tube was connected with the Fessenden oscillator, it was possible to follow the movement of ships many kilometers away. The detection of submarines during this time also depended almost entirely on hearing their engines or propellers, and on determining the direction from which these sounds were coming. This system of detection was not very satisfactory. It did point out, however, the work that had to be done. Our submarines still needed improved transducers for signaling among themselves when submerged. This spurred the development of underwater sound apparatus for the Navy.

In the spring of 1917, a Franco-British commission visited the United States to acquaint the leading American scientists with Langevin's and Boyle's experiments. As a result of the visit, the Navy began extensive investigations on the quartz transducer at its experimental station at New London. Other programs were soon underway at Columbia University, at several other universities, and at the General Electric Company laboratories in

Schenectady, New York, and in Lynn, Massachusetts. A similar program was carried out in Italy under the direction of Professor Lo Surdo, to whom Langevin had also sent a slab of quartz.

In addition to these developments, the Navy soon learned the need for directional capability. The binaural sense was the basis for early designs that were later modified by adding a third hydrophone to resolve the front/back ambiguity. While such equipment was introduced into service, it was clearly not the total answer to naval requirements. However, if any reader has available to him two hydrophones and a stereo amplifier, binaural listening in the ocean is fine entertainment.

Between the Wars

Between World Wars I and II, three uses of ocean acoustics based on wartime experience were developed extensively; namely, echo sounding, sound ranging in the ocean, and seismic prospecting.

Echo sounding was developed in several countries. The French Langevin/Chilowsky model was the first high-frequency system. It employed a piezoelectric oscillator as source and receiver of sound. British models under Admiralty sponsorship eventually were developed and patented by A. B. Wood, B. S. Smith, and J. A. McGeachy. Commercial models were produced by Henry Hughes Company, Ltd., about 1925. This model was a high-frequency type and used a magnetostriction oscillator. In the United States, the Submarine Signal Company developed a series of echo sounders to which they gave the name Fathometer. Their early models were based on the Fessenden oscillator as source and receiver (low-frequency).

M. Marti in 1919 patented a recorder to echo sounding that has probably affected our lives far more extensively than any other development of ocean science. His recorder consisted of a sheet of paper constrained to move slowly beneath a pen that wrote on the paper, while repeatedly traversing the paper from one edge to the opposite edge in a direction perpendicular to the motion of the paper itself. The pen was driven laterally to its own motion across the paper by an electric signal from the output of the echo sounder. Thus, successive echoes could be viewed side-by-side; and, with the passage of time, a profile of the ocean floor was portrayed as the ship proceeded on its course. This portrayal was not only a useful means of visual display for study purposes, it also proved immensely powerful as a signal-processing device for recognizing echoes in a high-noise background. By the early 1930s, various adaptations of this principle of recording had been

widely adopted in echo sounding. Since that time, similar displays have been developed for facsimile transmissions, in cathode-ray tube displays, and in the television and computer industries.

Long echo-sounding profiles were first made in the early 1920s. Perhaps the first practical application was made, appropriately enough with the Marti sounder, while exploring a cable route between Marseilles, France, and Philippeville, Algeria, in 1922. The most comprehensive survey of that period known to me was the work of R. W. Veatch and Paul Smith (1939) of the U.S. Coast and Geodetic Survey, whose work for the first time presented in great detail the intricate topography of continental slopes off the United States. This work was completed by 1939.

The U.S. Coast and Geodetic Survey also experimented extensively with providing geodetic control by ranging with the combination of simultaneously transmitted radio and sound signals. The radio broadcast the instant that sound was transmitted, and the acoustic travel time could be measured by noting the interval between radio signal and corresponding sound signal. The Coast and Geodetic Survey found in a long series of acoustic/geodetic surveys that the sound intensity and, for that matter, the apparent speed of sound was highly variable. Hence, adequate geodetic control could not be maintained. They were well into investigations of the causes of these acoustical inadequacies when World War II erupted.

The "Shadow" Zone

It is necessary at this point to tell one sea story — that of the *Atlantis* and the *USS Semmes* off Guantanamo Bay. I have told you of the variability of intensity and speed of sound experienced by the Coast and Geodetic Survey in their attempts to establish geodetic control by horizontal sound ranging. The Navy of the mid-1930s at the Naval Research Laboratory (NRL) was seeking to improve submarine hunting by echo ranging. They were working at considerably higher frequency — 20 to 30 kilohertz — than the Coast Survey, but were experiencing difficulty with large variations in sound intensity. Some of this variability appeared to have a diurnal cycle. Their equipment operated more or less according to specification in the morning, but would not produce any echoes from submarines from early afternoon on, except at very short range.

This effect was persistent in the Cayman Sea, south of Guantanamo Bay, Cuba, and rendered

their method unreliable there. Similar performance was experienced in many other places. NRL scientists working for Dr. Harvey Hayes theorized that some daily cycle of change in the ocean might be causing this deterioration in performance. So they sought advice from the then young institution of oceanography at Woods Hole, Massachusetts. After some discussion with scientists there, including Columbus Iselin (director 1940-1950 and 1956-1958), a decision was made to conduct simultaneous tests of the sonar equipment and measurements of the state of the water acting as sound medium.

It soon became apparent that the upper levels of the ocean were heated each day by the tropical sun so that by early afternoon there was a layer 4.5 to 9 meters thick that was 1 to 2 degrees Celsius warmer than the uniform layer of water beneath. There was a somewhat gradual decrease of temperature with depth through this warmer layer. Its appearance during the day corresponded exactly with the deterioration of sonar ranges. The acousticians and oceanographers did not take long to deduce that the warm layer caused sound entering it to bend downward, thus casting an acoustic shadow within which a submarine could sit with impunity. This was 1937.

It was a minute but important part of the Navy's preparation for a world situation that looked more and more unsettled. (Many older readers may recall that work was not publicized.) It also was the birth of the discipline now called ocean acoustics. In the next five years, many scientists volunteered to serve the cause of maximizing the impact of sonar on winning the war. They brought into ocean acoustics many analytical and experimental skills. It was also a time of conceiving new ideas.

The SOFAR Channel

Maurice Ewing, based on early hints while he was a physics professor at Lehigh University in Pennsylvania, was convinced that sounds could recognizably propagate hundreds — possibly thousands — of kilometers through the ocean if both source and receiver were correctly placed (Figure 1). There was not a chance to marshal resources to test such an idea with a war going on. But he persisted, until in 1945 such tests were made between Eleuthera in the Bahamas and Dakar, West Africa.

Small explosions were heard well above the noise of the ocean at distances exceeding 3,000 kilometers. Propagation took place in a ubiquitous permanent sound channel of the deep ocean. Ewing called it the SOFAR channel (SOund Fixing And Ranging). In addition, Ewing, J. L. Worzel, and



Figure 1. Maurice Ewing, right, and Allyn Vine inspect an early On-Bottom Seismograph (OBS) outside the Physics Department, Lehigh University, Pennsylvania, about 1939. (Courtesy J. L. Worzel)

several colleagues at Woods Hole were able to study long-distance propagation in shallow water (Figure 2). Chaim Pekeris constructed his celebrated normal mode propagation theory on the basis of their data. This concept of elastic wave propagation in layered media has allowed us to understand and model the complex acoustics of shallow water. It has also provided a theoretical tool for understanding many of the complexities of elastic waves generated by earthquakes (or nuclear explosions) in the earth and propagated long distances in the outer layers of the earth.

By 1946, others of us were pondering the significance of the SOFAR channel. Allyn Vine, William Schevill, and I deduced that it behaved as an acoustic lens that produced badly distorted real images (convergence zones) of the source at the depth of the source, and with equal horizontal spacing from it. We secretly tested these ideas in the summer and fall of 1947 and then reported our results to the Navy's Bureau of Ships. They directed us to undertake further studies. Meanwhile, for long-distance signaling, we recognized that we could not always rely on the SOFAR channel and, therefore, we devoted part of our energies to studying the reflection and scattering of sound from the ocean floor.

It soon realized that when bottom echoes of an explosion were filtered and recorded at different frequencies, the lower frequency bands penetrated

deeper into the bottom. Furthermore, in large areas of the Sargasso Sea, the echoes appeared to have reflected from discrete reflectors of great horizontal extent rather than being random reverberation.

Other scientists — Ernst Weibull of Sweden and Russell Raitt of the Scripps Institution of Oceanography — were making similar deductions from work in the Mediterranean Sea and the northeastern Pacific Ocean, respectively. Meanwhile, Ewing was developing a team of geophysicists and geologists in the Geology Department of Columbia University. They immediately applied Ewing and Worzel's experience in acoustics and marine seismology to studying sea-floor geologic structures off the East Coast of the United States, but mostly in shallow water. The method they employed is called the refraction method, which was originally developed for oil prospecting. It consists of measuring the travel time of explosion energy along the sediment and rock layers in a pattern in which the distance between explosion and receiver is systematically varied from tens of meters to several kilometers.

In 1949, Ewing's group and ours at Woods Hole collaborated in extending these refraction measurements to the deep ocean between Woods Hole and Bermuda. Raitt at Scripps and Maurice Hill, John Swallow, and Tom Gaskell of Cambridge University in England were separately applying the same method to study structure under the deep ocean in the Pacific and the eastern Atlantic (Figure 3). Merle Tuve and Howard Tatel of the Carnegie Institution of Washington made a number of long-refraction profiles across continental margins. Gaskell and Swallow in 1950 made an important series of world-circling refraction measurements from *HMS Challenger*, a ship named for the famous *Challenger* of 19th century oceanographic fame. Those measurements marked the beginning of worldwide attention to the structure of the earth's crust beneath the oceans. Subsequent refraction measurements provided much of the scientific basis for the modern hypothesis of plate tectonics (see *Oceanus*, Winter, 1974). The refraction method is used somewhat less today, but is presently being re-examined for new applications.

Meanwhile, after several years (1949-1956) of partial discouragement with trying to understand a large volume of reflection data in the deep sea, we at Woods Hole discovered that only by spacing our observations very close together could successive echograms be successfully correlated and interpreted as layered sediment, or rough rock surfaces. This discovery was promptly shared with Ewing. The work led directly to the



Figure 2. J. L. Worzel, an early bombardier and geophysicist in the campaign to measure sediments and rock of the ocean; photograph about 1939.



Figure 3. Russell Raitt, center, of the Scripps Institution of Oceanography in California, rigs for a seismic refraction profile with colleagues in the Pacific in the early 1950s. (Courtesy Marine Physical Laboratory, Scripps Institution of Oceanography)

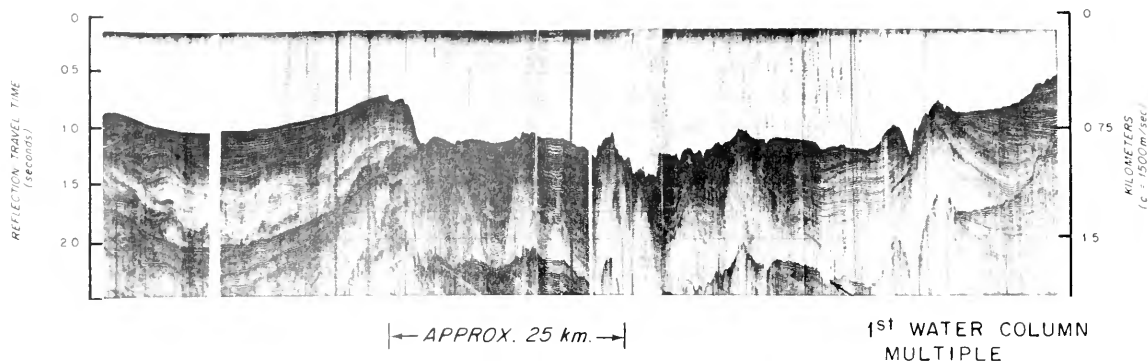

Figure 4. An interesting Continuous Seismic Profiler record from the continental shelf off Cadiz, Spain, in the approaches to the Straits of Gibraltar (R/V Chain 82, 1964). Here sedimentary bedding has been greatly distorted, possibly by compressional forces between the African and European continents.

Continuous Seismic Profiler (CSP), which was patented by the Woods Hole Oceanographic Institution (inventors, Hersey and S. T. Knott) in the early 1960s. This device has turned out to be useful largely because of its striking display of reflection profiles that has given them the deceptive appearance of geologic cross sections (Figure 4). The technique was quickly combined with towed arrays of receivers and broad spectrum sources and various signal processors to provide a specialized variety of seismic equipments used in oil exploration at sea and by seagoing academic geophysicists. It is likely that this development is, except possibly for the echo sounder, the most intensely used application to come from ocean science in the last 20 years.

The refraction method depends on acoustic energy between roughly 2 and 30 Hertz (Hz). The CSP employs the spectrum from roughly 15 to 500 Hz. The relatively high-frequency echo-ranging sonars (typically 24 kilohertz [kHz] of World War II demonstrated to C. F. Eyring, Ralph Christiansen, and Raitt at the wartime Navy Radio and Sound Laboratory in San Diego, California, that they were receiving diffuse echoes from the volume of the water. These echoes were arranged roughly in horizontal layers whose depths were on the order of 400 meters at noon, but migrated to the surface during twilight and early evening. At dawn, they migrated downward to complete a daily cycle. Subsequent work by Martin Johnson, a marine biologist at Scripps, led to the conjecture that the responsible scatterers were actually small animals that were known to perform a corresponding daily migration.

Robert Dietz, then at the Naval Electronics Laboratory, San Diego, found that these scattering layers were ubiquitous in deep waters, except possibly in Arctic and Antarctic waters (Figure 5). Victor Anderson showed that individual scatterers scattered sound with 180-degree phase change (a

pulse of sound exactly inverted when it reflected from a single scatterer). This meant that they were markedly more compliant than the surrounding water. For example, the individual scatterers could be caused by a gas bubble or a drop of oil. Richard Backus, a biologist at Woods Hole, and I were able to show that some of these layers were resonant. That is, they scattered sound much more strongly at certain frequencies. Furthermore, we were able to show that the resonant frequency of a particular layer migrated downward as the layer migrated toward the surface, and conversely. Some layers changed resonance from as high as 30 kHz to less



Figure 5. Beginning in 1949, explosives were used to study the spectrum of the deep scattering layers. Shots were fired at depths of less than a meter to assure sound radiation of a single pulse. The plume illustrated here was a very familiar scene at sea, when studies were underway to determine the diurnal migratory habits of small fishes in the deep ocean when responding to changing solar illumination. (Courtesy Scripps Institution of Oceanography)

than 12 kHz in their total migration. Others less so. The exact relation between resonant frequency and depth indicated that the scatterers were gas bubbles, which we conjectured were contained in the swim bladders of planktonic fishes. Interest, research, and conjecture about the deep scattering layers peaked from about 1949 to 1957, and have continued of steady if less interest to the present.

Eric Barham, then at the Naval Undersea Center in San Diego, and Backus have made independent demonstrations (based on visual observations from submersibles and acoustic data) that several different kinds of fish and invertebrates are responsible for some of the known scattering layers. The acoustic investigations, taken with the vast scientific data on the animals themselves, make a fascinating scientific world to behold, especially when observed in nature. We still know only parts of their story. (For a more complete account, see *Proceedings of an International Symposium on Biological Sound Scattering in the Ocean*, sponsored by the Maury Center for Ocean Science [U.S. Navy Department], 1970.)

Animal Sounds Pursued

Since antiquity, fish, whales, and crustaceans have been known to make sounds. During the 19th century, some species of fish were studied anatomically for their ability to produce and detect sound, but specific interest in animal sound production in the ocean burgeoned only during World War II. Animal sounds that might mask ship or submarine sounds in one or another acoustic system were the objects of wartime investigations. Since then discoveries about the complexity, variety, and almost humanoid quality of some marine animal sounds have been a repeated delight for us all. Prominent among the animal sounds studied in World War II were the snapping shrimp (*alpheus*) and the croaker. These and a few others were identified with their source, and their geographic and seasonal occurrence was investigated within wartime limits of feasibility.

From 1945 for about twenty years, there was intense and widespread interest in studying sea animal sounds. I suppose it is fair to say that interest was more or less proportional both to the intensity and complexity of the resulting sounds. A few investigators avidly pursued fish, crustaceans, and other lower animal sounds. Marie P. Fish and W. H. Mowbray presented sound analyses of 208 species of fish in 1970. William N. Tavolga edited the proceedings of a wide-ranging symposium on *Marine Bio-Acoustics* that was published in 1964 by

Pergamon Press in New York. Comprehensive reviews of work in this area have been provided by William Schevill, Backus, and this author (see Chapter 14, Volume 1, of *The Sea*), and interest in the subject is evident from numerous books and articles. The field is still ably investigated but, for a variety of reasons, somewhat less strongly supported than 10 to 15 years ago. There is a considerable literature of reports on individual species of sound-making mammals, mainly whales (see page 50).

These developments of the last 30 years have all continued, waxing and waning in response to available budgets, requirements, and interest. The seismological applications in the ocean have grown in size of investment and in comprehensiveness of world coverage, but they have grown narrowly. We continue to emphasize the delineation of structure. There are recent signs that efforts to improve the art are being encouraged. We are looking into the energetics of seismic transmission in the water and in the sediments, and are beginning to discover what they can tell us about the constituents and physical/chemical properties of our medium, as well as its shape and structure.

A most important aspect of ocean acoustics is the understanding of the influence of the ocean on sound propagation. Research and increased understanding of sound propagation has proceeded with varying but always strong emphasis in Navy and some academic laboratories in this country, Canada, New Zealand, Australia, several countries of Western Europe, and in many other nations possessing advanced technology, especially the Soviet Union (see page 30). Navy applications of acoustics are found throughout the acoustic spectrum from less than 20/30 Hz to greater than 200/300 kHz.

Ocean Acoustic Theory

I have given no account whatever of the development of the mathematical theory of ocean acoustics. There has been little basic research in ocean acoustic theory because it can and has been largely borrowed from optics, radio wave propagation, or from Lord Rayleigh, the 19th century giant whose interest was largely air acoustics. Nevertheless, many adaptations of other theory take on a special fascination and a number of special problems when applied to ocean acoustics. In 1945 and earlier, ray theory from optics and seismology was used to trace sound paths in the ocean. Later, the normal mode theory, refinements of ray theory, and other approximations to

fundamental wave theory were developed and applied to ocean acoustics. In the late 1940s, one could reproduce rays over a period of several days (Figure 6). Twenty years later, in 1968, with many stages of digital computer development behind us, a much more detailed ray diagram could be computed and automatically plotted in less than an hour (Figure 7). Today, using very fast computers and a more comprehensive and accurate approximation to equations describing sound propagation (called the parabolic equation method), we can reproduce a contoured vertical profile of the sound field as shown in Figure 8. In Figure 9, a ray and parabolic equation portrayal of the same sound field are shown superimposed. Despite this display, much remains to be done both in measurement and in theory for reliable prediction of ocean acoustic processes.

There is yet another area of ocean acoustic interest; the precise measurement by sound of distance in the ocean. By using short bursts of high-frequency sound, it has long been possible to measure short-distance separation between two objects. For example, it is possible to control the position of a camera 3 to 5 meters off the bottom in water several kilometers deep. The method can sense changes of position of less than 30 centimeters. More recent refinements (see page 22) permit us to establish relative position over several kilometers horizontally with an uncertainty of about

6 centimeters, and changes of relative position greater than 3 centimeters can be sensed. The essence of these techniques is being applied industrially to guide the oil drilling bit into a borehole in the deep ocean. This maneuver was first achieved operationally on 25 December 1970 aboard *Glomar Challenger* in 3,900 meters of water at the Venezuela Basin in the Caribbean Sea at Site 146 on Leg 15 of the Deep Sea Drilling Project of the National Science Foundation.

Active sonars have always had interference from the scattering of non-target reflectors. The scattering is called reverberation. It can come from the rough ocean surface, from objects in the water, such as the deep scattering layers, or from the bottom. It is possible to learn useful data about the shape of the bottom by deliberately emphasizing in design the bottom reverberation. By this means, objects can be located on the bottom. Early models were developed by both American and British Navy laboratories during World War II to locate bottomed mines. This development has continued in several navies, but in addition the technique has been pursued for large-scale exploration of the sea floor. Over the last decade, the National Institute of Oceanography in Britain (now the Institute of Oceanographic Sciences), under the leadership of M. J. Tucker, and Brian McCartney, has built and used a side-scanning sonar called

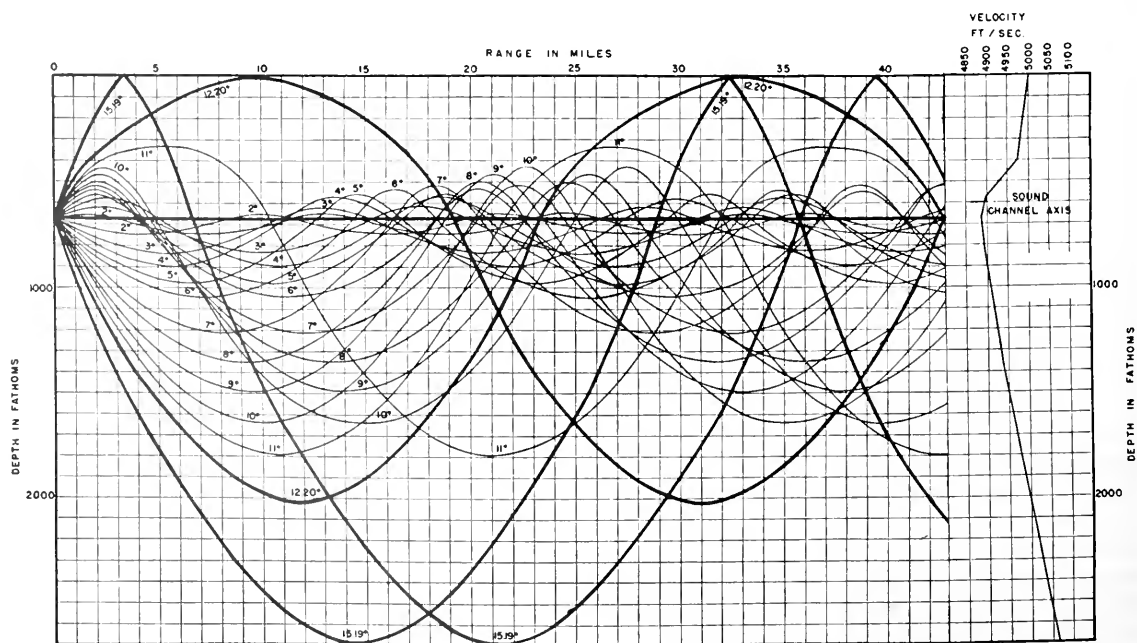

Figure 6. A typical ray diagram illustrating sound in the SOFAR channel in the Atlantic Ocean. (Courtesy Geological Society of America, Memoir No. 27)

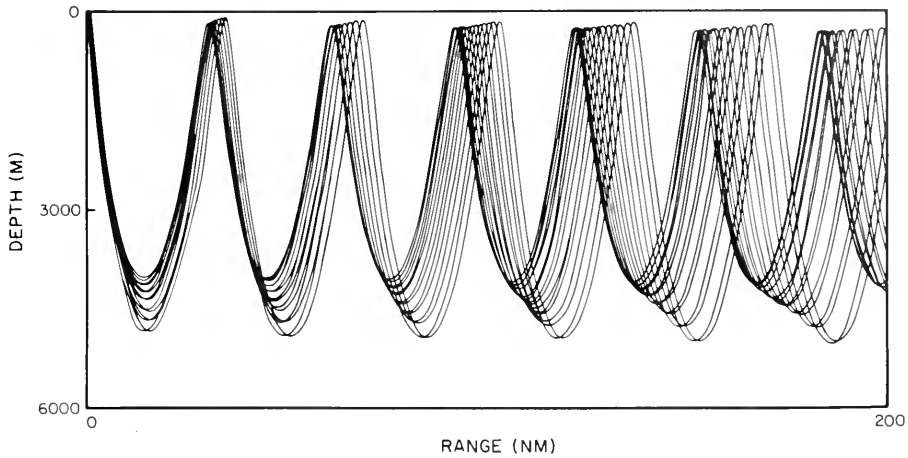

Figure 7. Rays traced from a digital computation of ray geometry for propagation in the outer part of the SOFAR channel. Note the close crowding of rays at regular intervals at the edge of the bundle of rays. These are now known as convergence zones. Many rays that reflect from the surface and the bottom of the ocean are not shown. (Courtesy Office of Naval Research)

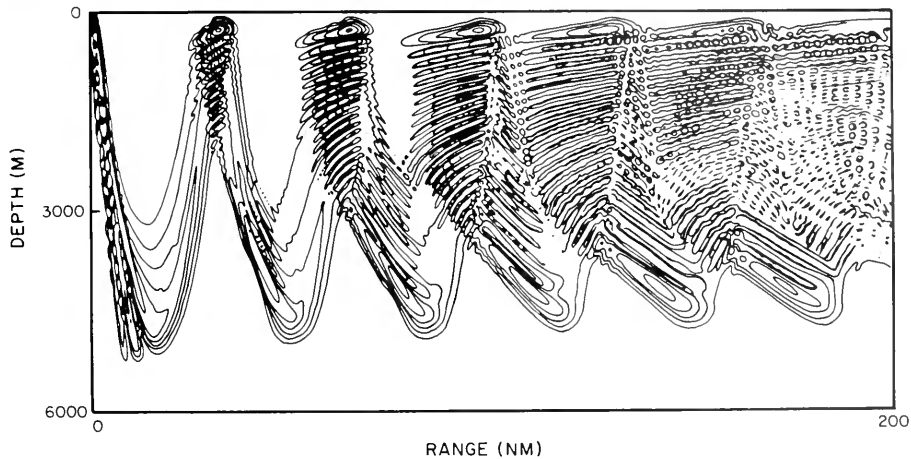

Figure 8. The same sound field as illustrated in Figure 7 is computed here, using a different approximation to wave theory — known as the parabolic equation — as the basis for drawing contours of equal sound intensity. The parabolic equation, unlike ray theory, accounts for the diffraction of sound that is of little significance at high frequencies, but results in a smearing of the sound field at low frequencies. (Courtesy Office of Naval Research)

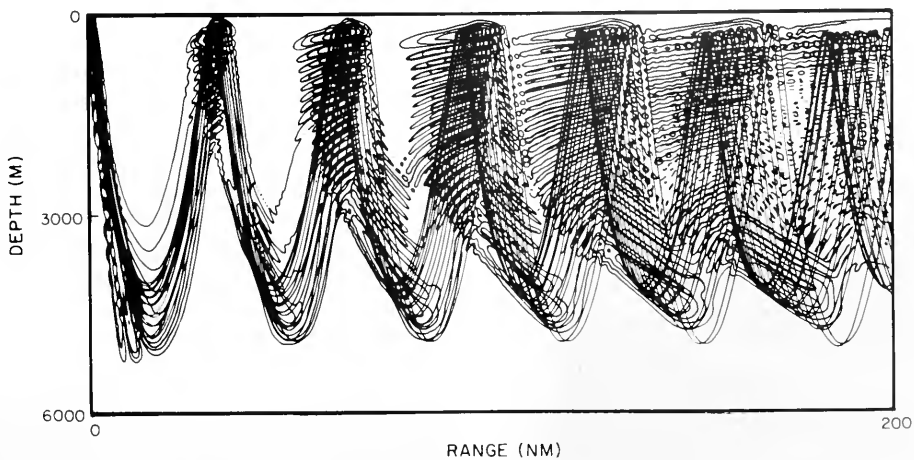

Figure 9. The ray theory computation of Figure 7 and the parabolic computation of Figure 8 superimposed. The parabolic computation was made for 25 hertz. Note the marked extension of the sound field outside the area defined by the rays. This is a result of sound diffraction that is not accounted for by ray theory. (Courtesy Office of Naval Research)

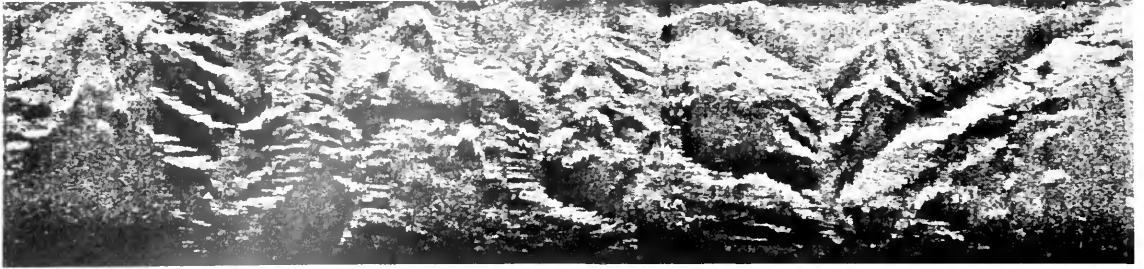
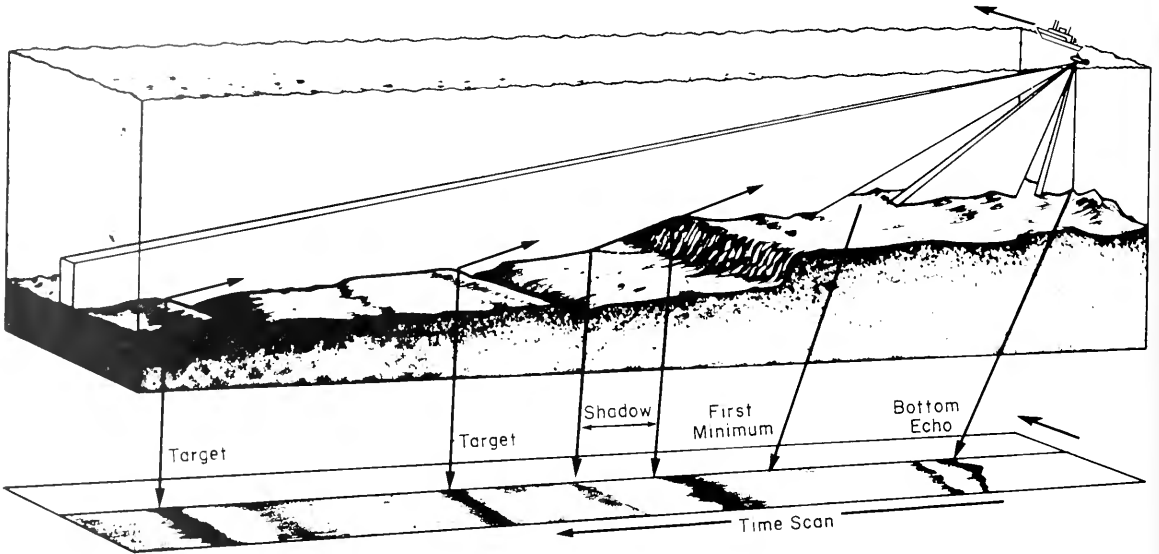

Figure 10. A side-scan sonar (4 kilohertz) inspection of the continental slope from the shelf edge south of the English Channel into the Bay of Biscay. Bright areas are shadows; dark areas have been ensonified. Note the marked diagonal channels and the intricate tributary system feeding the main diagonal canyons. The scene is approximately 12 kilometers from top to bottom and 48 kilometers long. (Courtesy Institute of Oceanographic Sciences, Britain)



The Gloria system — a long-range side-scan sonar developed at the Institute of Oceanographic Sciences in Britain. The upper view shows the ocean floor, Gloria; and her towing ship. Below is the corresponding acoustic recording. (Courtesy Institute of Oceanographic Sciences, Britain)

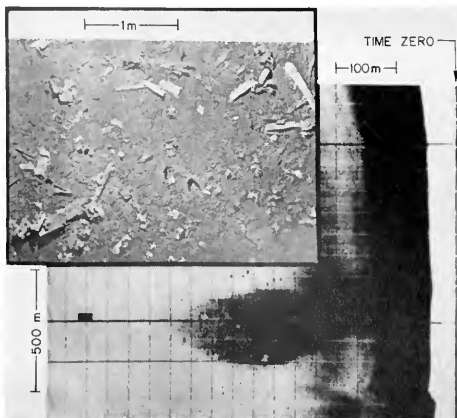

Figure 11. A Deep Tow side-looking sonar record (110 kilohertz), showing variations caused by changes in the texture of the sea floor. Here the smooth mud surface of the Nitnat abyssal fan off Washington is interrupted by a patch of small metal fragments resulting from the disposal of a munitions ship.* The low-level backscattering of sound from the mud surface is interrupted by the intense backscattering from the metal fragments. The photo (insert) shows the exploded remains as seen by one of the Deep Tow cameras, confirming that few large sections remained intact (From R. F. Lonsdale, R. C. Tyce, and F. N. Spiess. 1974. Near-bottom acoustic observations of abyssal topography and reflectivity, Physics of sound in marine sediments, Loyd Hampton, ed., Plenum Press).

*Several years ago, a series of overage explosives were loaded into munition ships that were to be disposed of. These ships were positioned and sunk with arrangements to fire the explosive when the ship had sunk to a predetermined depth. The energy from the resulting explosion was observed as it propagated over very broad areas in the Pacific Ocean.

Gloria. It is powerful enough to record reverberation from the ocean floor out to 19.2 to 24 kilometers athwartships of the observing ship. It inspects fish schools in the water or records a shadow graph of bottom topography along the path of the ship (Figure 10). Following its development between 1965 and 1970, *Gloria* was used in shallow water near the British Isles, in several locations in the northeast Atlantic Basin, on the Mid-Atlantic Ridge (in Project FAMOUS), and in the eastern Mediterranean south of Crete.

During this period, Fred Spiess at Scripps developed and used a much smaller-scale side scanner on a vehicle called the Deep Tow (see page 40). The Deep Tow can also measure the earth's magnetic field near the bottom, take photographs, and measure local relief (Figure 11).

In the future, it should be possible to expand and improve our ability to portray the underwater scene using extensions of the side-scanning techniques. Considerable advances in resolution and ability to make accurate measurements are certainly possible. Whether and how rapidly these developments will occur depends largely on scientific interest. Industrial applications of echo ranging, such as the side-scan technique, have been used in fisheries operations for nearly 30 years. The Scandinavians were among the first to use echo ranging to find fish soon after World War II, but this soon spread to many other countries. Excellent sonar equipment has been available in the United States for many years, but American fishermen have been far slower to adopt it than others (see page 59).

The Days Ahead

To summarize, the present understanding of ocean acoustics is based on scientific conjecture and research traceable back to the ancient Greeks. Science and technological development pursued with accelerating intensity parallels that of all the physical sciences since the 17th century. Ocean acoustics has borrowed its theoretical foundations from other branches of physical science, notably electromagnetic propagation (light and radio waves), seismology, and structure and properties of matter.

Its future potential in science is probably greatest for assisting oceanographers to monitor and interpret ocean processes, still an intensely developing field. If sufficient demand/opportunity persists, substantial improvement in both large- and small-scale ocean charting can be achieved. The probable nature of near-term improvements is

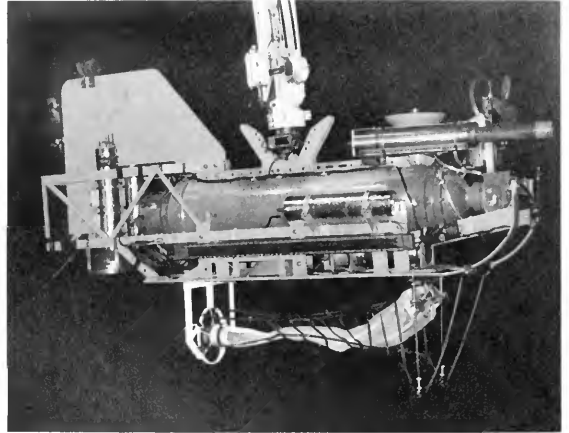

The Deep Tow vehicle designed by the Marine Physical Laboratory at Scripps Institution of Oceanography, La Jolla, California. Outfitted with highly complex electronic equipment, it has allowed oceanographers to map the fine geologic structure of the bottom in more detail than ever before. The apparatus on the bottom of the Deep Tow is a recently developed, remotely-actuated, opening-and-closing net for catching plankton near the sea floor. (Courtesy Scripps Institution of Oceanography)

increased resolution, accuracy, and basic scope and detail of survey attainable for given investment. Point-to-point signaling in the ocean, meagerly developed now, can be greatly improved in quality, speed, and distance. The monitoring of industrial operations and the promotion of safety through the use of acoustics are in their infancy, and probably will be greatly advanced in the next decade.

Formerly the Chairman of the Department of Geology and Geophysics, Woods Hole Oceanographic Institution, J. B. Hersey is now Deputy Assistant Oceanographer for Ocean Science, Department of the Navy, Office of Naval Research, Arlington, Virginia.

Acknowledgement

Much of the pre-World War II account of ocean acoustics is based on a manuscript prepared by the late Helen Roberts, during several years of work (1953-1957) at the Woods Hole Oceanographic Institution.



R. C. Spindel at 41° 31' .47 North, 70° 40' .32 West. (Photograph by Anita Brosius)

ACOUSTIC NAVIGATION

BY ROBERT C. SPINDEL

I am sitting in my office in the Bigelow Building of the Woods Hole Oceanographic Institution, Woods Hole, Massachusetts. I am 4.2 statute miles south of Falmouth just over the Eel Pond Channel, opposite the local boatyard. I am at 41° 31' .47 North latitude, 70° 40' .32 West longitude. These simple descriptions would enable you to find me. Locating things on land is something we do routinely. We have maps, street signs, the American Automobile Association and, as a last resort, we roll down the window and ask a friendly stranger.

The situation at sea is quite different. Landmarks are rare and street signs nonexistent. We can easily describe the location of a particular point with apparent precision, but steaming to that point is not so simple. A sextant in the hands of an experienced navigator can establish a fix to within 3 or 4 kilometers. The conventional deep-sea, semi-automatic navigation systems on larger ships do a bit better, but they do not give the precision required of many modern research, industrial, or

military missions. Under ideal circumstances, the most sophisticated long-range navigation systems can fix a position within 100 meters. A precision of about 2 kilometers is more often the rule. Acoustic navigation systems can yield accuracies of several meters, and a new type of acoustic navigation under development has yielded precision to several centimeters.

Marine navigation is the process of directing the motion of a vessel at sea from one point to another. The earliest form was probably piloting, whereby positions were determined relative to points on land. Navigational aids, such as buoys, lightships, and lighthouses were used to extend the practical range of piloting to regions far from shore. The ancient lead line was used to pilot in relation to the bottom. Modern electronic navigation can be thought of as a form of piloting in that most radio navigation systems project onto the surface of the earth imaginary lines of position that are referenced to fixed geographical locations. Acoustic navigation

is also an extended form of piloting, with sound waves being used in place of radio waves. Like the lead line, acoustic echo sounders, or fathometers, are used to navigate relative to the ocean bottom. Celestial navigation, which is still practiced today, makes use of the known and highly predictable motion of the earth, sun, planets and stars to determine position.

The fundamental principle behind most modern radio navigation is the measurement of the travel time, or phase, of a radio wave. Signals are transmitted from several fixed locations to the ship or object to be positioned (Figure 1). The time taken by the signal to make the traverse establishes the distance from the fixed location to the ship, and hence the position of the ship. Some systems measure the travel time directly, others compare the arrival times of pairs of signals. The latter systems are known as hyperbolic systems since the loci of time differences are hyperbolas. The familiar Loran, Omega, Lorac and the British Raydist and Decca systems are all forms of hyperbolic systems. Since radio waves travel at the speed of light (3×10^8 meters per second), very small time differences must be measured to secure accurate fixes. A radio signal travels 300 meters in a millionth of a second. Under ideal conditions, these systems can yield accuracies from 50 to 500 meters.

Radar fixes can be taken by transmitting pulsed high-frequency radio waves to shore sites or moored marker buoys of known location. Near shore, they can be very accurate, often to within a fraction of a meter. But far from shore, the performance of radar drops off sharply, until at ranges greater than 200 kilometers hyperbolic systems are superior. Satellites transmit radio signals from a known location in space. Accuracy is about 100 meters. While these techniques are

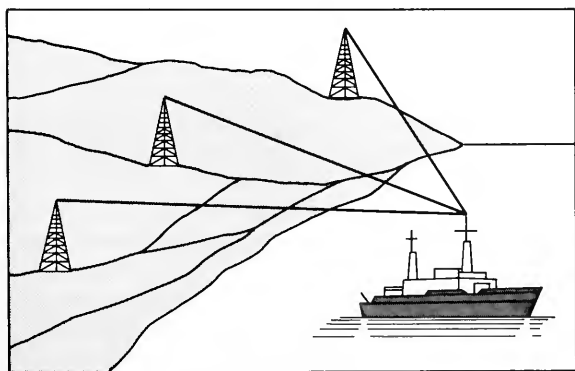

Figure 1. Modern electronic navigation systems measure travel times from fixed shore points to the ship. Radio waves traveling at the speed of light are used.

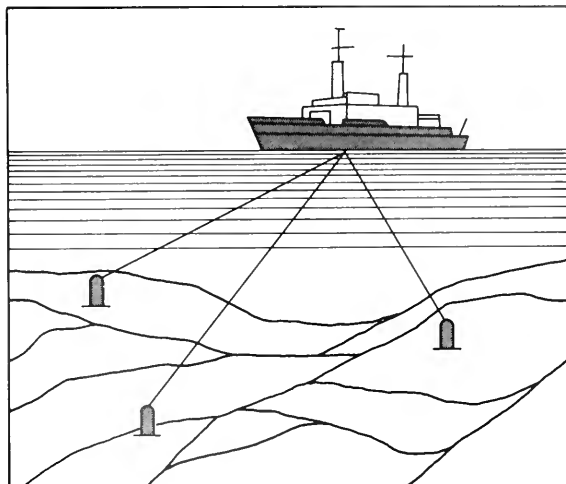

Figure 2. Acoustic navigation systems measure travel times from fixed bottom locations to the ship. Acoustic energy traveling at the speed of sound in water is used.

adequate for a large portion of navigation needs, they do not supply the precision required in many special applications. Furthermore, they all require the tracked object to have an above-surface antenna and are of little value in positioning entirely submerged objects, such as submarines or oceanographic instruments.

Acoustic navigation also makes use of a travel-time measurement from a known location to the tracked object (Figure 2). But these systems use underwater sound rather than radio signals. The speed of sound in water is 200,000 times slower than the speed of radio waves, so that time measurements can be 200,000 times less precise for the same fix accuracy. A sound wave takes 0.2 seconds to travel 300 meters.

Acoustic navigation systems can give fixes to less than a meter when operating at high frequencies and short ranges. They can be operated independently of shore stations, and made portable and readily deployable, even from small vessels. They are relatively inexpensive to implement, require no above-surface antennae, and therefore are ideally suited for the tracking of submerged objects. In one form or another they have been used in a variety of applications, including the tracking of towed and free-falling instruments; the dynamic positioning of ships for drilling purposes; the navigation of submersibles, such as the Woods Hole Oceanographic Institution's *Alvin* and France's *Trieste*; the finding and re-entry of boreholes; the deployment of underwater instrumentation; and the establishment of reference grids for underwater search and recovery missions.

Bottom Contour Navigation

Perhaps the most straightforward form of acoustic navigation uses a carefully constructed, finely detailed bathymetric map of the ocean bottom in conjunction with an echo sounder. The ship monitors bottom contours by acoustic soundings (measuring the acoustic travel time between the transmission of a sound pulse and the arrival of its reflection off the bottom) and positions itself relative to a distinctive bottom feature (Figure 3). This technique can be particularly effective for a submarine when a detailed map of the ocean bottom is available and when bottom characteristics are sufficiently varied to yield unique positions.

Extremely narrow acoustic beams must be used to achieve precise fixes for surface vessels. The usual ship echo sounder illuminates a circular area on the bottom about 2,000 meters in diameter in 4,000-meter deep water. The signal used to determine water depth directly beneath the ship is actually composed of echoes from all bottom features in the 2,000-meter circle. Even narrow-beam echo sounders illuminate fairly large circular patches. This method is best suited to deep submersibles where the illuminated bottom area can be as small as a 20-meter circle.

The main drawback of bottom contour navigation, whether using near-bottom or near-surface vehicles, lies in the necessity for an accurate map of the bottom relief. These maps are usually obtained by echo sounding with ships that are navigated by conventional means. One of the most intensive surveys of the ocean bottom occurred during Project FAMOUS (French-American Mid-Ocean Undersea Study) several years ago. An example of a detailed bathymetric chart produced for this experiment is shown in Figure 4. The chart is contoured in 5-fathom (about 10-meter) intervals. Even with a chart as detailed as this it is difficult to navigate from the surface to an accuracy of more than 500 meters. This chart, incidentally, took many months to prepare.

Fixed-Bottom Reference Elements

A more direct approach to acoustic navigation at sea uses an array of acoustic devices that are fixed to the ocean bottom. These constitute benchmarks, or street signs, and allow the accurate positioning of a vehicle with respect to their location. Systems of this type come in several forms; some offer high precision at short range, some offer low precision at long range. Ocean-bottom arrays have been used by the deep-sea drilling ship *Glomar Challenger* to maintain station above a borehole, by oil-drilling

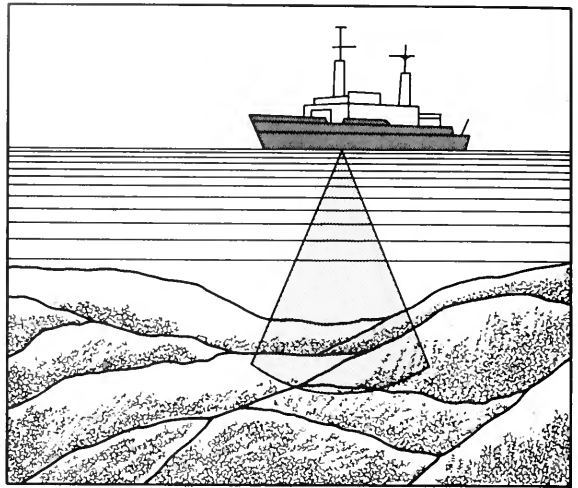

Figure 3. Position can be determined by echo sounding.

rigs and oil-prospecting companies, and by almost every major oceanographic research institution. They have been used to navigate submersibles in underwater searches (they guided *Alvin* to a downed F6F aircraft in 1,700-meter water, 150 miles southeast of Cape Cod in 1967), and to locate anchor positions of deep-water moorings. They have enabled the tracking of towed cameras and dredges so that bottom photographs and bottom samples can be correlated.

These devices determine the range from the submersible or tracked object to bottom beacon or transponder by measurement of acoustic travel time. If the bottom device is a beacon, it repeatedly emits a short acoustic pulse at a precisely known time. The pulse is received by the submersible or tracked object and the time of reception is recorded. If the sound pulse travels in a straight line, the distance from beacon to object is the product of the speed of sound in water (about 1,500 meters per second) and the travel time. A single-beacon travel time constrains position to lie on the surface of a sphere. Travel time to two beacons places position on a circle that is formed by the intersection of two spheres. A third travel time gives the final necessary data for an unambiguous fix. This procedure is illustrated in Figure 5.

Another procedure has the ship rather than the beacon emit the acoustic pulse, which is received by bottom-mounted hydrophones. The hydrophones must be linked by cable or radio to shore, or back to the ship, so that it is useful only near shore or in shallow water. Several systems of this type are currently in use by the U.S. Navy to test the performance of weapon systems, such as torpedoes, or to evaluate tactical exercises. Rather elaborate

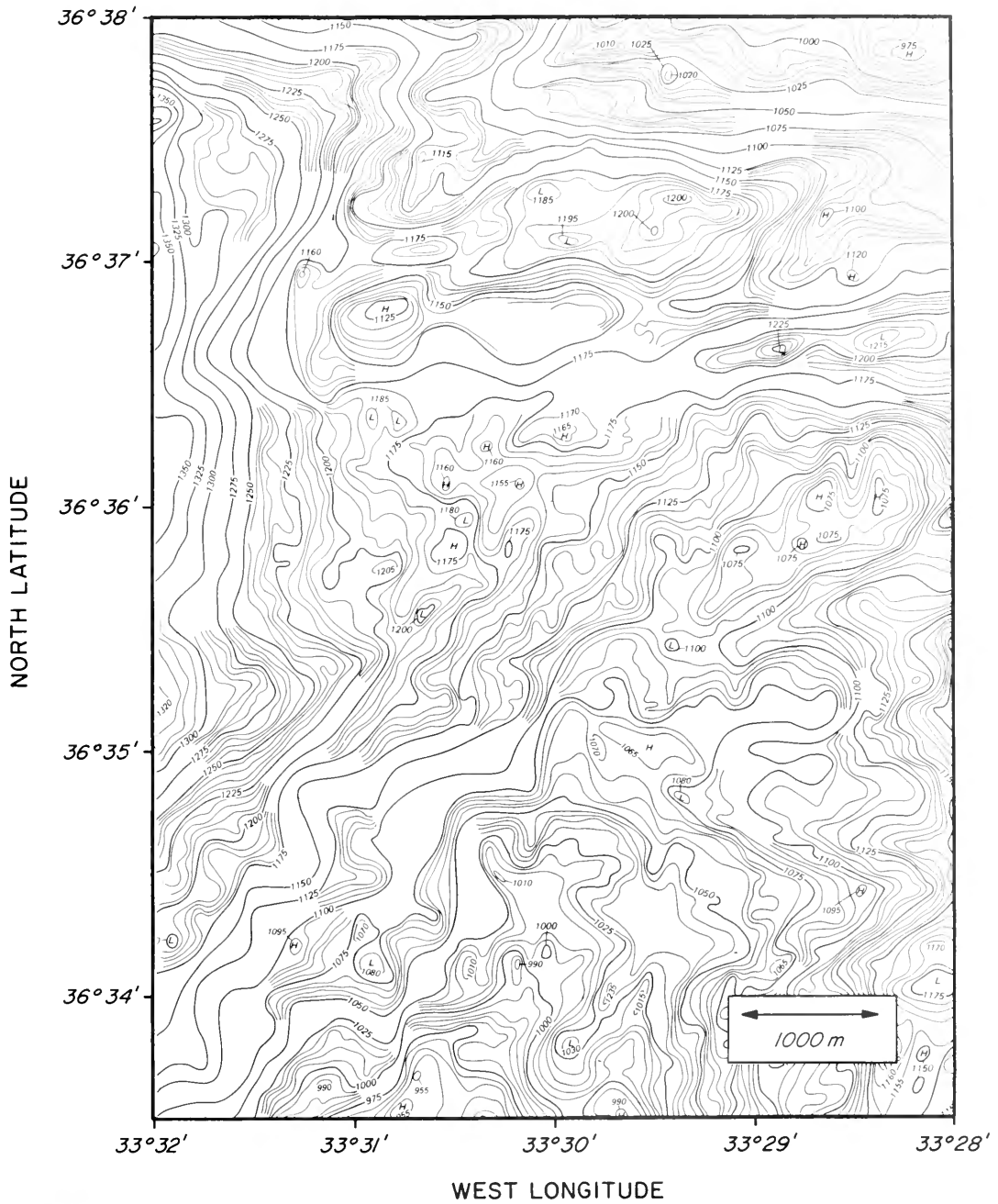

Figure 4. Detailed bathymetric map near the Mid-Atlantic Ridge. (Adapted from J.D. Phillips and H.S. Fleming, *Multi-Beam Sonar Studies of the Mid-Atlantic Ridge Rift Valley 36° to 37° North*, Geological Society of America Map Series, in press)

installations are to be found at the Atlantic Undersea Test and Evaluation Center (AUTECE) in the Bahamas, and at the Barking Sands Tactical Underwater Range (BARSTUR) in Hawaii.

Fixed Hydrophones for Long-Range Tracking

Fixed hydrophone systems operating at low acoustic frequencies are used for long-range tracking and

navigation with diminished accuracy. A particularly interesting example is the tracking of SOFAR (SOund Fixing And Ranging) floats in the Atlantic. These floats (developed at Woods Hole) are constructed to be neutrally buoyant at a specific ocean depth. They emit acoustic pulses on a regular basis that are received by shore-cabled hydrophones. The float position is obtained by

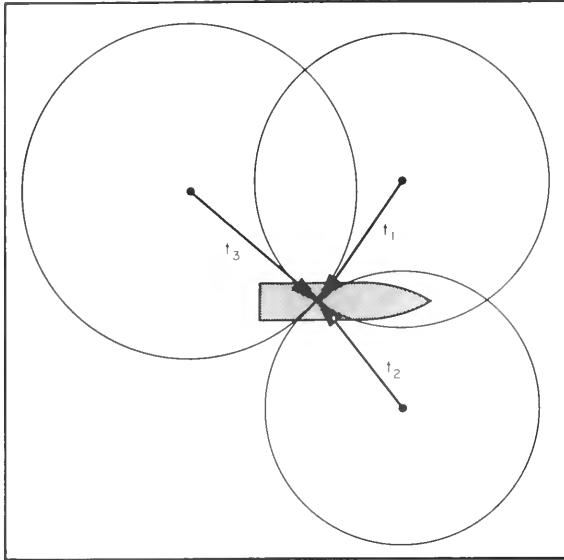

Figure 5. The acoustic travel time from three beacons, transponders, or hydrophones on the bottom provide a precise navigation fix.

triangulation, using the time difference between pulse arrivals at three such hydrophones. Over a period of time, the locus of float positions forms a continuous record of the direction and speed of subsurface current patterns (see page 30). It is commonplace to track floats hundreds of kilometers from shore.

Still another use of triangulation is employed in surface impact location systems. An object striking the sea surface generates a sound pulse that is received by fixed hydrophones. Fallen satellites and missile and meteor impact sites have been found this way. The location of underwater seismic disturbances has been pinpointed through the measurement of the arrival time of the resulting sound pulse at fixed hydrophone locations.

Bottom Transponders for Precision Navigation

Remote, deep-ocean, precision navigation systems usually employ acoustic transponders rather than beacons (Figures 6 and 7). The beacon requires an internal clock synchronized with a clock on board ship. It is prohibitively expensive to construct beacons with clocks of sufficient stability to maintain synchronism beyond a period of weeks. Transponders, on the other hand, stand a silent vigil, constantly on the alert for an acoustic command. They receive an acoustic pulse generated by the vehicle to be navigated and respond by emitting a pulse of their own. Each transponder, in an array of

fixed-bottom units, replies at a specific frequency, so that its signal may be distinguished from the others. Alternatively, each transponder may be interrogated at a different frequency, all replying at the same one. Aboard ship, the time of transponder "interrogate" is recorded together with the time of reply, thus establishing the acoustic round-trip travel time. Half this is the one-way travel time that is used to determine the distance to the transponder. The range of currently used transponder systems is about 12 kilometers; beyond that, absorptive attenuation of the sound signal becomes so severe that it is too weak to be detected. With a three-transponder system, about 500 square kilometers of area can be covered. If larger areal coverage is desired, a multi-transponder field is implanted. Variations of the transponder system are in use at almost all major oceanographic laboratories. Several have become available commercially, and are being used successfully by oil companies in conducting high-accuracy seismic surveys at deep-water locations.

Automation of transponder navigation systems has reached a high degree of sophistication. Pulses are automatically transmitted and received aboard ship. Times of transmission and reception are read by a small computer and ranges to the transponders are calculated. The computer performs the necessary geometric calculations to determine the ship position north-south, east-west and

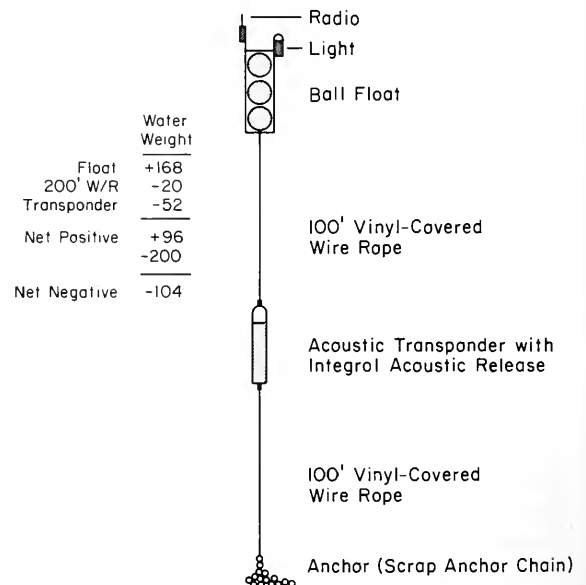

Figure 6. A typical navigation transponder mooring. The transponder and float can be recovered via the integral acoustically-commanded release. The radio and light are used to aid in finding the assembly on the surface.



Figure 7a. Preparing to deploy a transponder mooring.

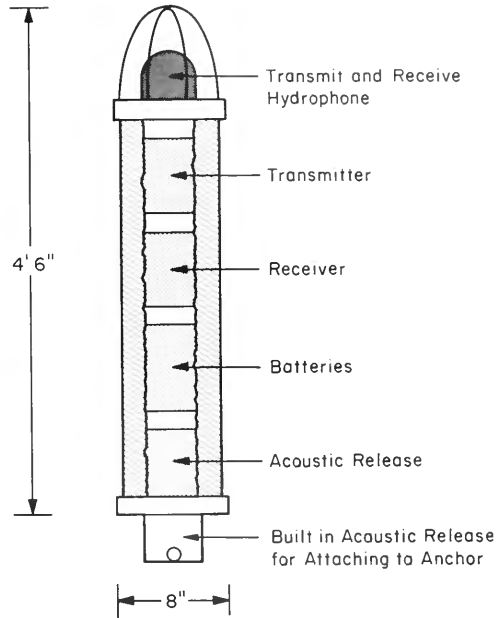

Figure 7b. Cut-away view of an acoustic navigation transponder.

vertically with respect to an arbitrary bottom point. Usually this point is selected to be one of the transponders, so that it serves as a benchmark for all navigation within the transponder net. An example of the computer output during a complicated series of ship maneuvers is shown in Figure 8.

The benchmark transponder can be left in place so that ships can return to precisely the same point in the ocean. This allows several ships to participate in a single experiment and yet accurately merge their acquired data, or to return to the work area — a drill hole, dredging site, or bed of manganese nodules.

Free-falling and towed instrument packages are equipped with acoustic transponder systems so that they may be accurately tracked (Figure 9). At the Marine Physical Laboratory of the Scripps Institution of Oceanography, the transponder system is used to navigate a deeply towed instrument package that contains various devices for measuring characteristics of the ocean bottom and water mass (see page 40). At the Woods Hole Oceanographic Institution, the transponder system is used by geologists and geophysicists to coordinate photographs of the bottom with dredge samples, to fix the impact point of core barrels, and to mark especially interesting points for return voyages. Physical oceanographers have used transponder navigation to implant a large tri-mooring, that is, a mooring with three legs joined at a single apex. (Requirements specified that the

anchor points be fixed to within 20 meters.) They also have equipped moored instruments with transponding units to record the variation in position of deep-ocean mooring lines as they waver back and forth in response to ocean currents and tides. Ocean engineers have used the transponder system extensively for maneuvering *Alvin*, especially in areas where the submersible has made multiple dives, such as in the Mid-Atlantic Ridge or the Cayman Trough.

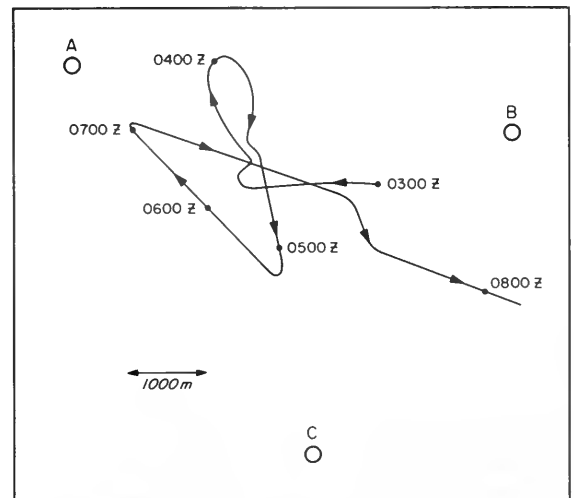

Figure 8. Track of the R/V Chain from 0300 to 0800 (t), 12 September 1973. Transponders are shown at A, B and C.

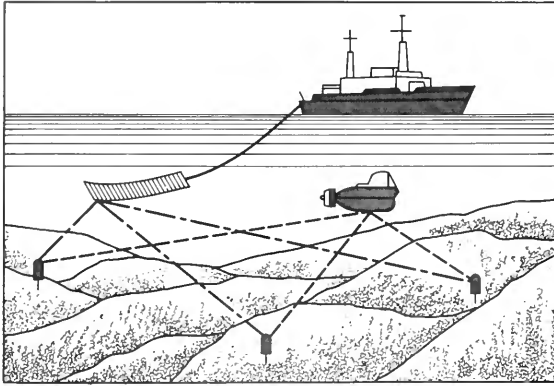

Figure 9. Acoustic navigation is used to track the position of towed instruments or the position of a submersible.

The overall accuracy of transponder systems is about 3 meters. It is limited by our knowledge of the speed of sound, which changes seasonally, monthly, daily, and sometimes even hourly. Rapid variations are usually limited to near-surface waters that represent only a small fraction of the total acoustic path. Deep-ocean variations are generally slow. The measurement of sound speed is quite critical to acoustic navigation, and great pains are taken to obtain an accurate in situ measurement. Accuracy is also limited because the sound path is not actually a straight line, but is curved. Rather sophisticated computer methods are used to account for ray bending. Finally, accuracy is limited to our knowledge of the position of the bottom units. These positions are obtained by careful, repetitive surveys, using computer-designed survey patterns, and are accurate to within about 2 meters.

Doppler Navigation

Transponder acoustic navigation systems have provided an enormous increase in the precision of localized deep-ocean navigation. However, even with errors of only a few meters, the limits of acoustic techniques have not been reached. Engineers are developing a different type of acoustic navigation that offers relative accuracies of several centimeters. It is based on the Doppler principle, the phenomenon that is observed when the pitch of the horn of an approaching automobile rises until it passes and thereafter falls. A device emitting a continuous acoustic tone is placed on the ocean bottom and monitored by the vehicle to be navigated. The following effects are observed: when the vehicle is motionless with respect to the continuous tone beacon, the frequency of the tone

measured on the vehicle is exactly the frequency emitted by the beacon. If the vehicle moves toward the beacon, the measured frequency is higher by an amount proportional to the velocity of the vehicle. If the vehicle moves away, the measured frequency is lower, again by an amount proportional to the vehicle velocity. These apparent changes in frequency can be measured to a high degree of precision, enabling the determination of velocity with great accuracy. Velocity, together with elapsed time, allows tracking of the vehicle; ten-centimeter accuracy is not uncommon, and the system can be made to yield even more accurate fixes.

Figure 10 shows a beacon tone received by a hydrophone fixed to the hull of a ship. The frequency is low when the ship is relatively stationary with respect to the beacon, and increases as the ship rolls toward the beacon. Half a roll cycle takes place between A and B. During this time, the ship has moved 1.2 meters.

Doppler navigation has been used by ocean engineers to enhance their ability to measure acoustic propagation phenomena. It also has been used to measure the motion of mid-ocean vertical moorings with great accuracy (see page 30), and to implement synthetic-aperture sonars. In fact, the routine implementation of this particularly valuable form of sonar awaited the development of high-precision acoustic navigation. Most sonar systems use arrays of hydrophones rather than a single one. A long, linear array gives improved signals and angular resolution but can be unwieldy and impractical. Instead of a line of many hydrophones, a synthetic-aperture array can be formed by moving a single hydrophone along a line. In order for this to work, position must be known to within a quarter of the wavelength of the signal being received. At 500 Hz, for example, a quarter wavelength is 0.75 meters. Using this notion, arrays of hundreds or even thousands of meters can be formed.

Acoustic techniques have proved to be extraordinarily appropriate for precision navigation at sea and for the long-range tracking and navigation of submerged objects. Though confined in the past principally to research and military applications, it is now used increasingly by the maritime industry. Our navigation requirements at sea are becoming more severe. Searches for oil and natural gas deposits are being extended from the relatively shallow continental shelf to the deep-sea environment. This operation requires precise seismic and bottom sampling surveys. If these natural deposits are to be exploited, precision navigation will be needed to implant well-head equipment and

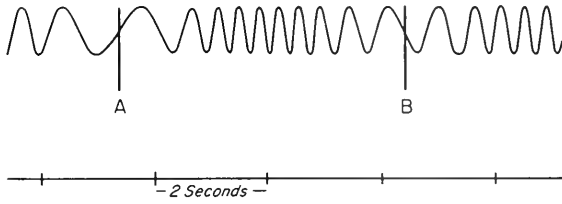

Figure 10. Doppler signal received by a ship-mounted hydrophone.

pipe systems. Ocean mining, which some feel may become practical in the near future, will also require precise navigating techniques. The possibility of disposing of nuclear wastes in the deep ocean is a subject of great concern at the present time (see *Oceanus*, Winter 1977). It is clear that careful placement and periodic observation of disposed canisters will require precision navigation. Undoubtedly acoustic navigation will play a major role in these and other activities.

Robert C. Spindel is an Associate Scientist in the Department of Ocean Engineering, Woods Hole Oceanographic Institution.

References

- Bowditch, N. 1966. *American practical navigator*. U.S. Naval Oceanographic Office. Washington, D.C.: U.S. Government Printing Office.
- Heckman, D.B., and R.C. Abbott. 1973. An acoustic navigation technique. In proceedings of symposium *Ocean 73*, pp. 591-95. N. Y.: Institute of Electrical and Electronics Engineers.
- Spiess, F.N., M.S. Loughridge, M.S. McGehee, and D.E. Boegeman. 1966. An acoustic transponder system. *Journal of the Institute of Navigation*, 13:154-61.
- Spindel, R.C., R.P. Porter, W.M. Marquet and J.L. Durham. 1976. A high-resolution pulse-Doppler underwater acoustic navigation system. *IEEE Journal of Oceanic Engineering*, 1:6-13.

Correction

In an article by Armand J. Silva—*Physical Processes in Deep-Sea Clays*—in the Winter 1977 issue of *Oceanus*, the water content profiles in cores taken north of Hawaii were reversed. The profile on Page 33 should have matched the Figure 1 caption on Page 32 and vice versa.



ACOUSTIC PROBING OF OCEAN DYNAMICS

by Robert P. Porter

The circulation of salt water about the earth's surface is a complex process that influences our lives. Boundary currents, such as the Gulf Stream, moderate our weather. The Gulf Stream changes shape and location in rough approximation to the seasons. The weather on the East Coast of the United States may worsen significantly if the stream moves further offshore. These circulating waters also carry nutrients essential to the maintenance of fishing grounds, such as the Grand Banks or the anchovy fishery off Peru.

Boundary currents are not monolithic; the stream meanders, splits into multiple currents, and throws off circulating cells or eddies (see *Oceanus*, Spring 1976). One or more of these eddies may cool the local ocean surface enough to influence atmospheric circulation. Such a cell can also introduce nutrient-enriched water into a poorly endowed region, changing the distribution of fish.

We must learn the complexities of the circulation patterns before we can understand their influence on the ocean environment. Techniques are now available for tracing Gulf Stream eddies for many months. Satellite maps of the stream can track the surface water but they do not reveal much about the underlying currents. Ship surveys are useful but expensive, time-consuming, and usually of short duration. In today's technology, only acoustic systems can sample the details of a sufficiently large area of the ocean for a long period of time.

The relationship between sound and the ocean is complex. The years during and immediately after World War II were spent trying to understand how the ocean alters sound passing through it. We know now that sound is reflected from the sea surface and that properties of surface waves can be extracted from the reflected sound. We know that sound passing through the Gulf Stream is altered by changes in the current and the temperature. Can we sort out this relationship so that we may measure currents and temperature changes by observing variations in sound? Work at the Woods Hole Oceanographic Institution and elsewhere is seeking to answer this question.

We now understand that the motions of waves in the ocean drastically affect sound propagation, and thus we can predict the characteristic behavior of these sound fluctuations. For example, cold Gulf Stream rings, those masses of clockwise-circulating cold water thrown off by the stream, can cause the intensity of sound at a listening station to increase. As an eddy crosses a transmission path, the intensity of the sound wave can change by as much as a factor of ten.

During the last decade, an acoustic range was established across the Florida Straits between Miami and Bimini. It was first operated by the University of Miami, and then by the Palisades Geophysical Institute in Miami, Florida. Measurements taken over a long period disclosed a

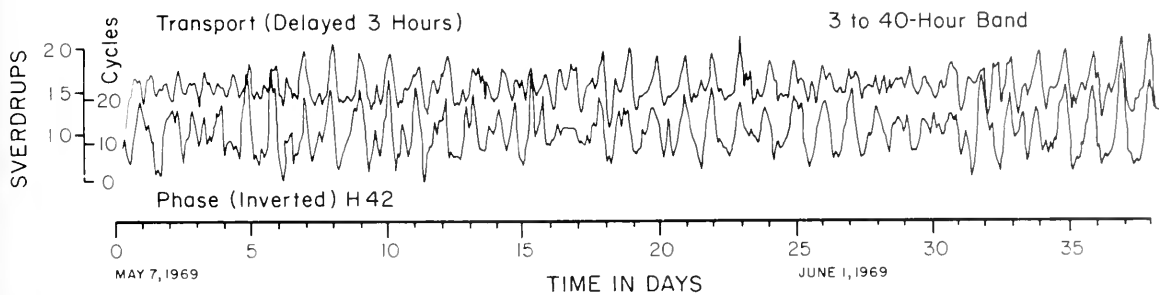

Figure 1. Comparison of acoustic phase and mass transport across the Florida Straits. The transport has been delayed 3 hours to optimize the correlation. One Sverdrup is about 4 cubic kilometers per hour. (Courtesy Palisades Geophysical Institute)

correlation between acoustic and oceanographic variables. The acoustic signal responds to changes in the Gulf Stream that are caused by tides. Figure 1 shows a comparison between the phase (a measure of the change in travel time) and the transport of water by the Gulf Stream. We see that both vary with the daily tides.

As we have shifted from studying how sound travels through seawater to utilizing this knowledge to explore the dynamics of the ocean, it has become clear that sound is a sensitive indicator of the average ocean condition along its propagation path. It can, for example, sample large expanses of ocean, yielding measurements of the average temperature and current. Conventional measurement techniques, such as moored current meters and the CTD probes (Conductivity, Temperature, and Depth), have disadvantages that make remote acoustic sensing techniques attractive.

CTD probes, for example, can yield a good snapshot description (typically, one lowering per 25 square kilometers), but the time evolution of the dynamic structure requires a prohibitive number of lowerings. Moored current meters can record ocean currents for as long as a year but are too expensive to provide adequate coverage of large areas. In addition, they sample only the water wetting the instrument and cannot measure currents with speeds less than 1 centimeter per second. Acoustic monitoring (remote sensing) has the promise of measuring the time and space evolution of the dynamic structure, with only a few sensors. It also is not limited to the immediate vicinity of the instrument; it can measure average conditions over 1 to 100 kilometers of ocean.

Physics of Sound in the Sea

Sound can travel great distances in the ocean because of a refractive channel that confines much of the acoustic energy in the water. Figure 2 shows an ocean temperature profile from the Sargasso Sea,

along with the resulting profile of the speed of sound. As the temperature decreases, so does the speed of sound. However, the speed of sound increases as the pressure and depth increase. At a depth of about 1,000 meters, the pressure and temperature dependence of the speed of sound counterbalance; at this point, the speed of sound reaches its minimum value.

For a sound emitter at the axis of the deep sound (or SOFAR) channel, the index of refraction is always smaller, both above and below. A ray of sound (Figure 2) is always bent toward the horizontal when transmitted from a sound source on

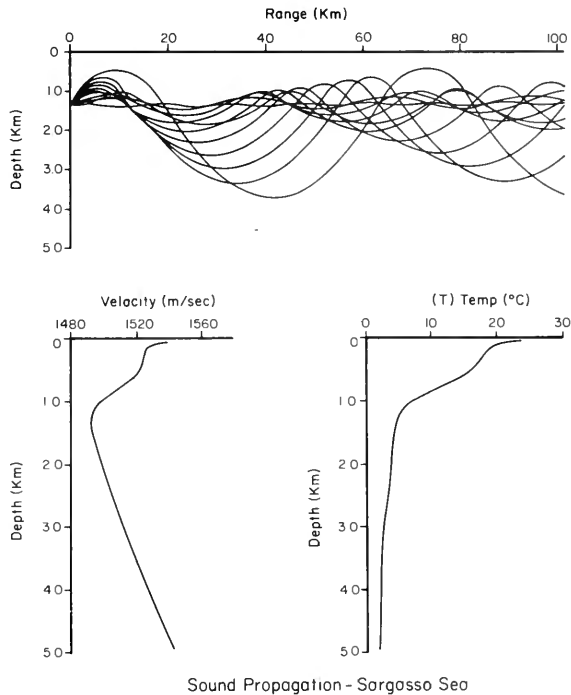

Figure 2. Propagation in the Sargasso Sea. A typical temperature profile and calculated sound speed profile has been used to calculate the ray paths. Only positive rays are shown leaving the sound source. Rays are refracted up and down about the sound speed minimum. A typical ray cycle is 72 kilometers.

the axis. Eventually, the ray will reverse direction, cross the channel axis, and cycle back and forth as shown in the illustration. For practical purposes, the sound is confined to a depth range between 500 and 2,500 meters.

Acoustic probing over ranges greater than 100 kilometers is limited to sound whose frequency or pitch is less than 1,000 Hertz (Hz). Long ranges of 800 kilometers can only be probed at frequencies below 400 Hz. Sound energy is lost at long ranges by absorption. Sound vibrates the water molecules and salt ions, which generates heat. The higher the frequency, the more acoustic energy is lost to heat. (Most of the energy is lost by vibration of one of the minor salts in seawater, magnesium sulphate.) The loss is logarithmic. At 100 kilohertz (kHz), the energy decreases by a factor of 10 at a range of 10 kilometers. At one kHz, the absorption loss increases by a factor of 10 at a range of 100 kilometers.

Sound transmissions have several properties that we seek to measure and then relate to ocean variables. A short burst of sound from a projector is shown in Figure 3. This burst travels by several possible refracted paths and arrives at the receiver as a series of short bursts. The time taken by each pulse to reach the receiver depends on the temperature and current along its path. The path along the axis of the sound channel has the longest travel time, because the average speed of sound is lowest along that route. Each received pulse has traveled a different path and can be used to determine average ocean properties along that path. The variations in travel time are random. Occasionally, two or more pulses arrive simultaneously. These interfering pulses can cause the received signal to become very large or very small.

Observed variations of pulse structure are shown in Figure 4. These data are the result of an experiment conducted by the Institute of Geophysics and Planetary Physics at the University of California, San Diego. A single, narrow pulse is emitted from a projector. Two major pulse groups arrive at the receiver 17,500 milliseconds and 17,530 milliseconds later. One minute later, at 0902, another pulse is emitted. Its received pulse groups are aligned in a three-dimensional display where pulse emission time versus arrival time is plotted with pulse energy shown in the vertical plane. The return at 17,500 milliseconds is a single pulse whose amplitude varies slowly over the 26 minutes of the record. The return at 17,530 milliseconds consists of a group of pulses whose amplitude varies greatly, with some pulses disappearing completely. Careful study of the figure shows that the arrival time of individual pulses in the group varies over the 26-minute interval. A computation of basic ray acoustics would predict only one pulse, arriving at 17,530 milliseconds. The reception of many nearly simultaneous pulses is the result of a complicated interaction between sound and ocean variables, such as temperature, salinity, and current. It is not known yet if this arrival structure can be used to determine measurements of the ocean variables.

Acoustic reception fits into two categories: saturated or unsaturated fluctuations. Saturated fluctuations are dominated by the addition of small random arrivals and obey statistical laws somewhat dependent on ocean dynamics. The fluctuations saturate at high frequencies or long ranges. For a 200 Hz sound burst, scattering becomes important at ranges between 100 and 300 kilometers. At shorter ranges, the fluctuations are unsaturated; the travel-time wobble is well-defined and related to ocean variables.

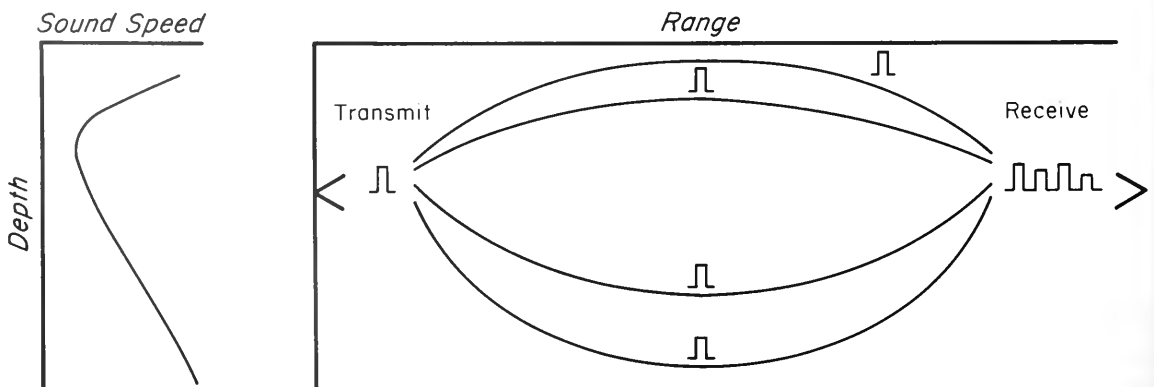

Figure 3. Propagation of short bursts. An emitted pulse travels along several different paths. Several pulses are observed at the receiver.

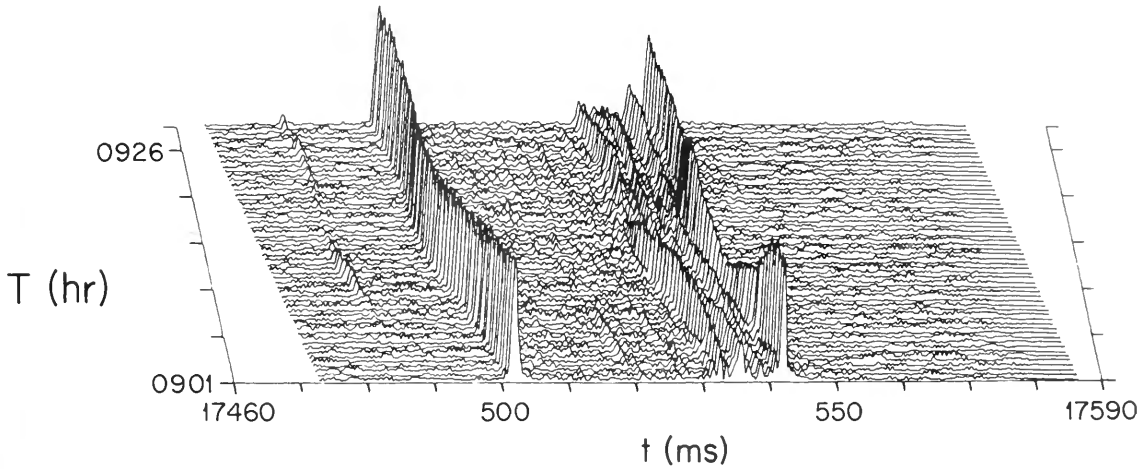

Figure 4. Stacked returns for pulses emitted once per minute. Each return consists of a pulse at 17,500 milliseconds and a pulse group at 17,530 milliseconds. (Courtesy Peter Worcester, University of California, San Diego)

Continuous tone transmissions, shown as the constant frequency wave in Figure 5, are also used to probe the oceans. The properties of these transmissions are not directly related to ocean variables. For unsaturated sound, the phase of a continuous tone signal is related to the vertical displacement of an isotherm — a line connecting points of equal temperature. Nevertheless, it is a great deal simpler to build this type of ocean probe (an instrument that transmits and records single frequencies) than to construct ones for short bursts.

There are many technical considerations that affect acoustic measurements, but these cannot be explored in depth here. The level of natural background noise in the sea, achievable power levels from sound projectors, sensitivity of receiving hydrophones, and data storage capacity all limit our ability to measure the amplitude and phase of sound waves (see page 5). The most important limitation on the measurement of travel time is the accuracy with which the time base can be computed. Acoustic transmission systems designed to measure currents of 1 centimeter per second for 100 days must have a time base that is accurate to 1 second in 1,000 years. These accuracies can be achieved with atomic frequency standards that are very precise because they are based on atomic resonances. For example, that of cesium is used by the National Bureau of Standards to define a second of time. It is still a challenge, however, to place systems based on atomic standards in the ocean.

Sound Probes of Ocean Currents

The SOFAR float program, developed by Thomas Rossby of the University of Rhode Island and

Douglas Webb of the Woods Hole Oceanographic Institution, is the most successful application of sound probing to date. The floats are untethered aluminum tubes, containing batteries, electronics, and a sound emitter that is adjusted to be neutrally buoyant at a particular depth, such as the axis of the sound channel. A picture of a typical float is shown in Figure 6. These devices emit bursts of sound picked up by sensitive listening equipment at widely scattered sites. During the Mid-Ocean Dynamics Experiment (MODE), which began at sea in 1973, floats were implanted west of Bermuda and tracked by listening stations at Bermuda, Grand Turk, and Eleuthera (see *Oceanus*, Spring 1976).

The acoustic travel times were used to calculate the location of each float, and their continuous drift was taken as a measure of the local current. Some twenty floats were launched during MODE, with many continuing to transmit for more than two years. Because the floats constantly changed position, the acquired data was not always easy to interpret. The object was to measure current as a function of both time and position.

During September 1975, ten floats were placed in Gulf Stream rings by Webb and tracked from Bermuda and other stations. Some showed

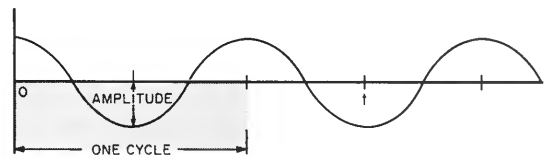

Figure 5. A continuous tone with phase reference at 0 time. The phase at time (t) is $1\frac{1}{2}$ cycles. The amplitude of the wave is half the peak-to-trough height.

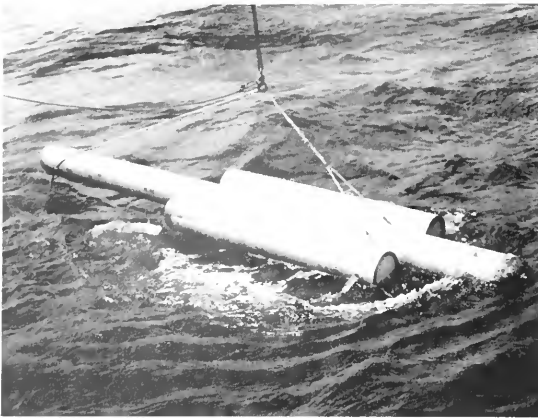

Figure 6. SOFAR float similar to those used during the Mid-Ocean Dynamics Experiment.

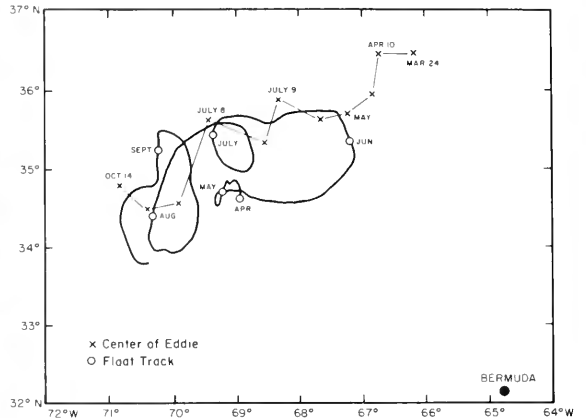

Figure 7. Gulf Stream ring and entrained float. The location of the eddy center is shown for the data indicated by x. The float track is the curve beginning in April and ending during September. (Courtesy Robert Cheney, Naval Oceanographic Office)

coherent motions. Figure 7 shows a cartwheeling float track. Independent evidence reveals that this float was caught in a rotating Gulf Stream ring that was moving slowly to the southwest. It remained in the ring and was tracked for more than two months.

The float-tracking program monitors ocean currents by using the gross travel time and its evolution over many months. Other measurements relate small-scale variations of acoustic properties to ocean dynamics, such as internal gravity waves. These waves are similar to ocean surface waves (which exist because of the great density difference between air and water). They have longer wave periods and wavelength than do surface waves because the density variations of seawater with depth are slight in the bulk of the ocean. The characteristic time scales are 20 minutes to 1 day, and space scales range from 10 meters to 10 kilometers. Most of the energy present is in the 10-kilometer waves. Internal gravity waves move water back and forth horizontally with an oscillation period of about a day.

Vertical internal wave oscillations produce changes in the speed of sound in the upper 1,000 meters of the ocean. Internal waves vertically displace isotherms by approximately 10 meters. A sketch of displaced isotherms is presented in Figure 8. Since the temperature at a given depth varies in time and with horizontal position, the speed of sound also fluctuates. A sound ray traveling through this region is refracted as well as alternately being speeded up and slowed down. The time taken by a pulse to travel between projector and receiver varies, due to the average influence of the internal waves

that are present along the ray path. Tone bursts have wobbling arrival times in response to internal waves. Continuous tones signals, which when received consist of the sum of sound traveling along many paths, each of whose travel time varies slightly, show evidence of interference. The amplitude can fall more than a factor of ten in a few minutes. The phase variations have greater stability and, with some restrictions, provide an adequate measure of travel time. At 200 Hz, we can electronically measure phase to better than 1 percent of a cycle, or 0.05 milliseconds.

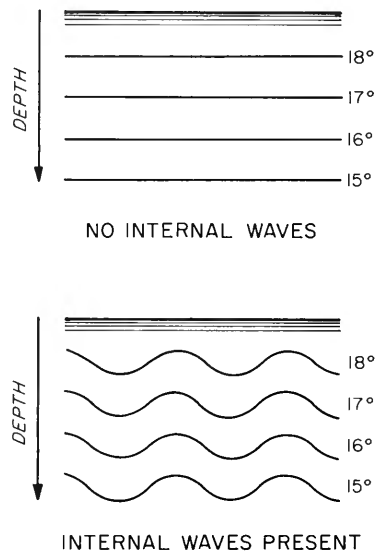

Figure 8. Isotherms below sea surface. The top shows ocean with no internal wave field, while the bottom shows isotherm displaced by internal waves.

At Woods Hole Oceanographic Institution, we have been studying the influence of internal waves on the phase and amplitude of low-frequency sound. Measurements are performed by mooring a sound source at the axis of the sound channel and, then, 200 to 400 kilometers away, mooring receiving instruments that record the transmitted sound. A photograph of the electronics assembly is shown in Figure 9. A photograph of the instrument case was shown at the beginning of the article. The moorings are free to sway with the deep-ocean currents and can move in rough, 300-meter circles. The acoustic wavelength is 7.5 meters at 200 Hz; the mooring motion produces phase changes of 40 cycles. Since the phase variations due to internal waves are about one cycle, the mooring motion must be known if the effect of internal waves is to be measured.

The motion of the sound emitter and receivers can be tracked acoustically. Around the base of each mooring, about 5 kilometers away, we place high-frequency acoustic beacons. The layout of the acoustic range is shown in Figure 10. A special, high-frequency receiver is attached to the mooring (see source mooring in Figure 10) or built into the acoustic receiver. This system can detect 3-centimeter changes in position of the emitter or receiver. For a 200-Hz signal, we can measure phase to an accuracy of a half degree.

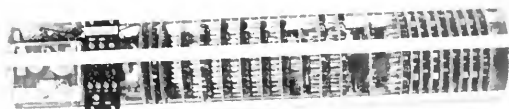

Figure 9. A view of the electronics assembly inside an acoustic receiving buoy.

This measurement approach is sensitive to vertical motions of the thermocline. Displacement of an isotherm produces a change in sound velocity. An acoustic wave passing through the internal wave region experiences a change in phase equivalent to a change in travel time. This phase difference is related to the displacement of an isotherm. The rate of change of the displacement is a vertical current that can be estimated from the rate of change of the phase. Figure 11 shows a comparison between direct measurements of vertical current and the acoustic measurement. Both are plots of the energy contained in each characteristic period. We see that at

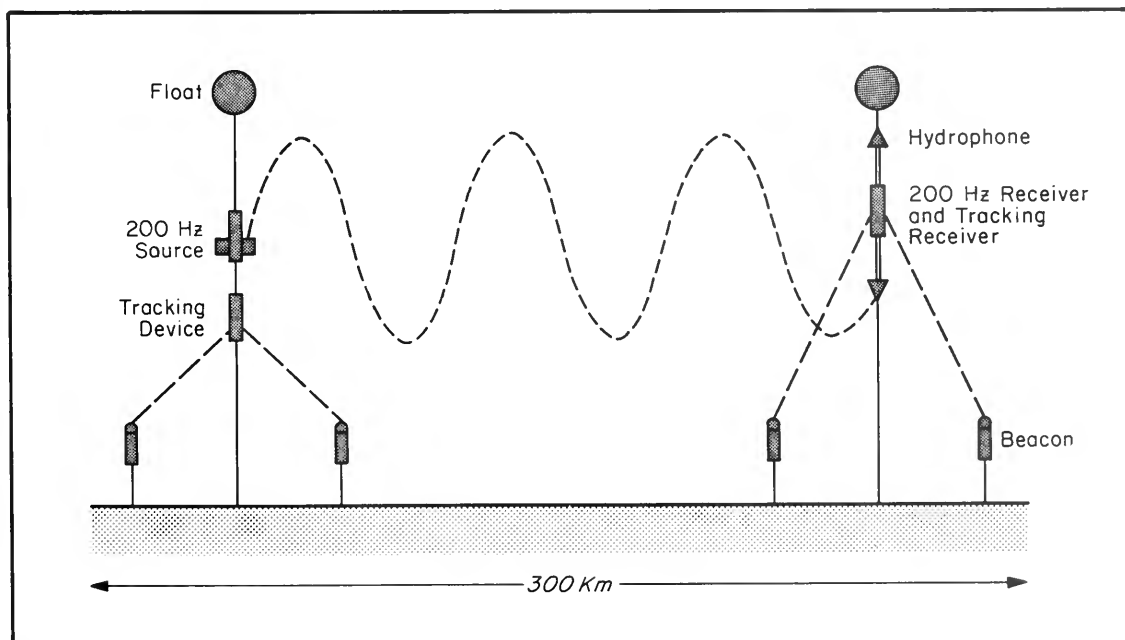

Figure 10. The Woods Hole Oceanographic Institution mobile acoustic range. A mooring with a sound source is buoyed off the bottom. The source motion is tracked relative to the two fixed beacons. The tracking receiver measures the change in position. The mooring 300 kilometers away contains hydrophones for listening to the 200 Hz source. A ray path is sketched. The position of the receiver is tracked relative to the fixed acoustic beacons.

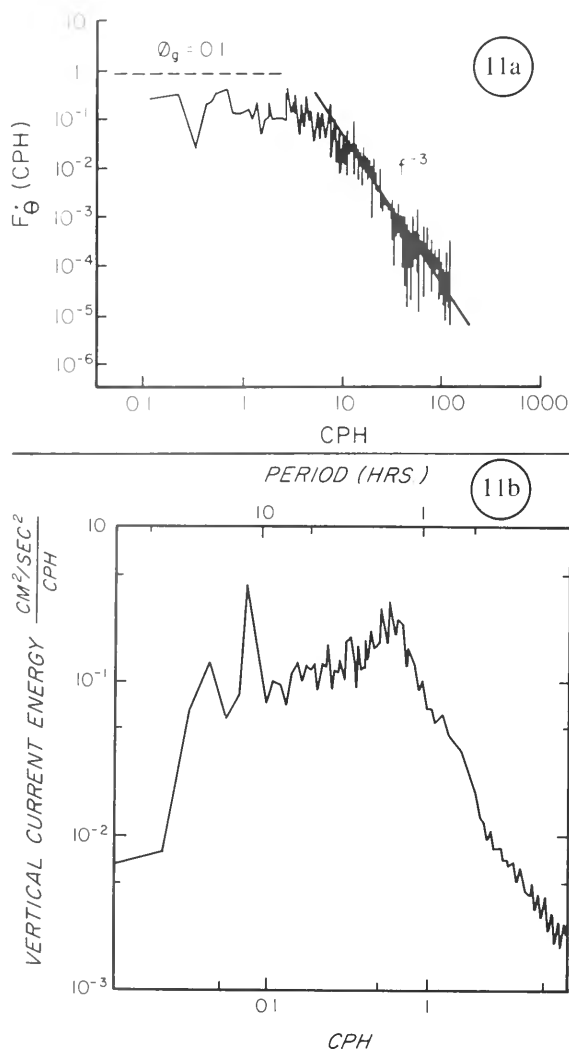

Figure 11. Comparison of acoustic phase spectra. Figure 11a is the spectrum of the instantaneous acoustic frequency (deviations from the 220 Hz carrier frequency) or phase rate. The spectrum is flat to a frequency of 5 cycles per hour after which it falls rapidly. Figure 11b is a typical spectrum of vertical current. It falls rapidly above 1 cycle per hour. (Courtesy Arthur Voorhis, Woods Hole Oceanographic Institution)

frequencies higher than 1 cycle per hour (CPH), the energy drops off rapidly. Very little internal wave energy can exist for shorter periods because internal waves cannot oscillate any more rapidly in the deep ocean.

The amplitude measurements are not simply related to oceanographic variables. Many paths combine to produce constructive (where all paths add) and destructive (where all paths cancel) interference, with total cancellation occurring at random intervals. In contrast, the phase variations fit a simple, intuitive picture; they are directly related to

isotherm displacements. This picture is valid, at least at shorter ranges and low frequencies.

Acoustic tracking systems produce very accurate measurements of mooring motion, which are required for acoustic measurements of internal wave structure and other oceanographic phenomena. Since the moorings move in direct response to ocean currents, we can also learn much about these currents. Figure 12 is a nine-day record of north-south and east-west displacements of a mooring point located 3,700 meters from the ocean floor. The dominant motion is the semi-diurnal, or daily tide. Spectrum analysis reveals that significant energy is present at the inertial frequency, which results from the Coriolis effect.* Two moorings separated by 5 kilometers have tidal motions that are well correlated. Figure 12 shows that the motion of the two moorings at the tidal period is nearly the same. Some very long-term phenomena are evident in the nine-day displacement data, but a much longer time record would be needed to precisely interpret this information.

The Applied Physics Laboratory at the University of Washington has performed a fixed-site experiment with a sound emitter located on the Cobb Seamount off the coast of Washington. The source transmitted short, high-frequency bursts to a receiver 17 kilometers away. The arrival time and amplitude of the pulses were measured in order to relate them to oceanographic parameters along the path. Measurements of temperature and conductivity were obtained by a remote, powered vehicle. Energy at tidal and inertial periods is quite evident in their data, with the daily tide being the major contributor.

Future Development of Acoustic Probes

Fixed acoustic installations permit direct measurement of travel time variations that are due solely to the ocean. Unfortunately, there are few geographical locations like the Florida Straits, where fixed measurements can be made and the scattering mechanism ignored. A complete acoustic probe requires that several receivers be spatially distributed. Such a fixed installation would require a substantial financial investment. The scale of ocean eddies and other dynamic phenomena (200 kilometers), as well as the useful range of the

*An apparent force acting on moving particles resulting from the earth's rotation. It causes moving particles to be deflected to the right in the Northern Hemisphere, and to the left in the Southern Hemisphere; the deflection is proportional to the speed and latitude of the moving particle. The speed of the particle is unchanged by the apparent deflection.

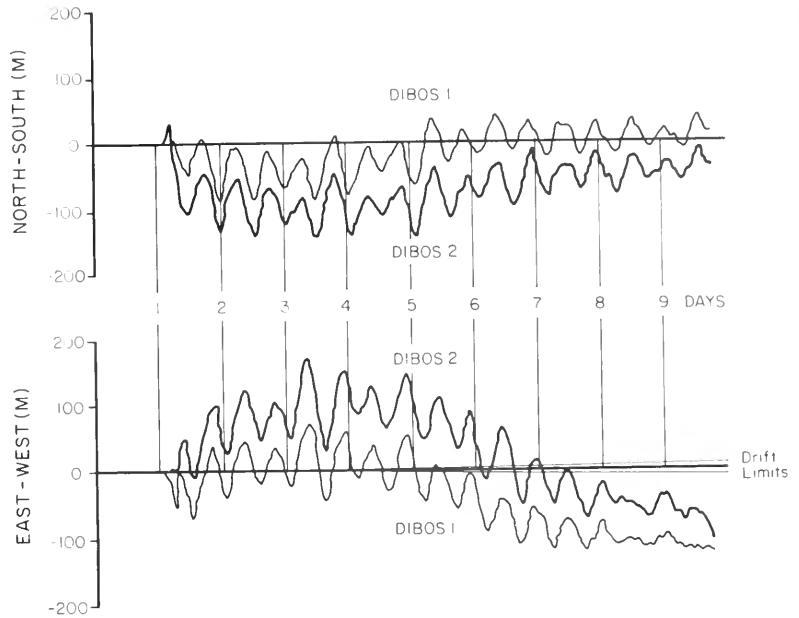

Figure 12. Horizontal motions of two midwater moorings separated by 5 kilometers. North/south motions are shown above; east/west motions are shown below. DIBOS 1 (a digital receiving buoy) motion is indicated by the lighter curve.

acoustic probe (100 to 200 kilometers), make it attractive to develop moored systems with a six-month data recording capability. Such systems would be easily handled from medium-sized research vessels, and would be comparable in cost to existing direct-measurement systems.

The temperature field of oceanic eddies can be mapped over several months by setting out an array of receiving moorings with a sound emitter located at the array center. The average temperature between source and an individual receiver will change as the eddy passes by. One-hundred-kilometer spacings between sensors appears sufficient to resolve the temperature field. Figure 13 illustrates a cold eddy in two different positions relative to the acoustic array. As the eddy passes, the travel time to the receiver on the left decreases (increased sound speed), while the travel time to the receiver on the right increases. Short bursts of sound can be transmitted, permitting the mapping of the eddy field at several depths.

A long baseline acoustic current meter is being developed by Walter Munk at Scripps Institution of Oceanography, LaJolla, California. This instrument can measure average current along a 50-kilometer baseline. It will be used in late 1978 to measure circulation energy in the California current. Sound travels faster with the current than against it; it is, in fact, carried along with the moving water. Two moored transmitter/receiver packages are shown in Figure 14. Each instrument is synchronized by precise clocks so that transmission is simultaneous. The receivers process and record

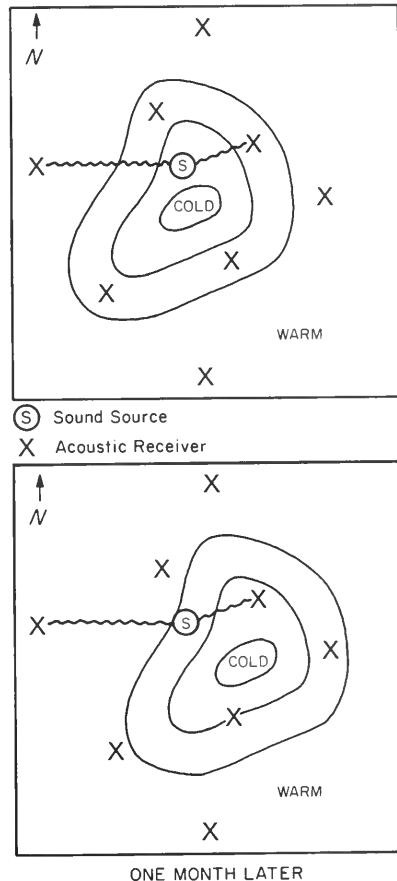

Figure 13. Example of an eddy moving through a net of acoustic receivers and sound source. The eddy moves to the east after one month.

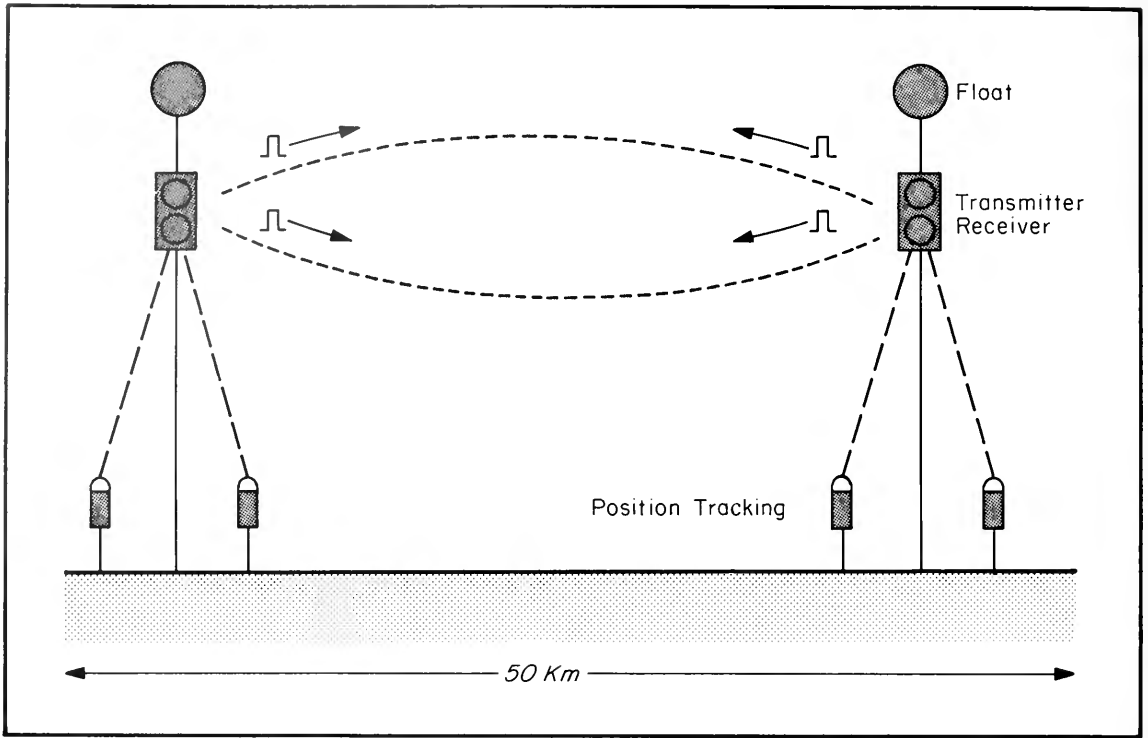

Figure 14. A long baseline current meter. Pulses travel both ways and travel time differences are measured. Mooring motion is tracked relative to fixed acoustic beacons.

the arriving burst; later analysis determines the travel times up and down stream. Since sound travels more slowly against the current, the two pulses do not arrive at the receivers simultaneously. The difference in the two travel times is a measure of the average current flow along the acoustic baseline. The moorings can lay over slightly with the current. In fact, the motion of the transmitter/receiver can be about the same as some of the weak currents that must be measured. By deploying an acoustic tracking system about the mooring, we can track the position of the transmitter/receiver to an accuracy of 15 centimeters. The tracking system is illustrated in Figure 14.

The experience of recent years has taught us that sound is greatly influenced by the condition of the sea through which it travels. We can now relate sound fluctuations to tides and internal waves. New experiments will utilize this data to monitor the ocean and to extract quantitative information on its energy and momentum. In a few years, we can

expect that acoustic probes will join the instruments routinely used by the oceanographer in his attempt to understand the movement of water around the globe.

Robert P. Porter is an Associate Scientist in the Department of Ocean Engineering, Woods Hole Oceanographic Institution.

References

- Cheney, R.E., W.H. Gemmill, M.K. Shank, P.L. Richardson and D. Webb. 1976. Tracking a Gulf Stream ring with SOFAR floats. *J. Phys. Oceanogr.*, 6:742-49.
- Dyson, F., W. Munk and B. Zetler. 1976. Interpretation of multipath scintillations Eleuthera to Bermuda in terms of internal waves and tides. *J. Acoust. Soc. Am.*, 59:1121-33.
- Rosby, T., A.D. Voorhis and D. Webb. 1975. Quasi-Lagrangian study of mid-ocean variability using long-range SOFAR floats. *J. Mar. Res.*, 33:355-82.
- Spindel, R.C., R.P. Porter and R.J. Jaffee. 1974. Long-range sound fluctuations with drifting hydrophones. *J. Acoust. Soc. Am.*, 56:440-46.
- Steinberg, J.C., J.G. Clark, H.A. DeFerrari, M. Kronengold and K. Yacoub. 1972. Fixed-system studies of underwater acoustic propagation. *J. Acoust. Soc. Am.*, 52:1521-36.

Abstract Art or Acoustics?

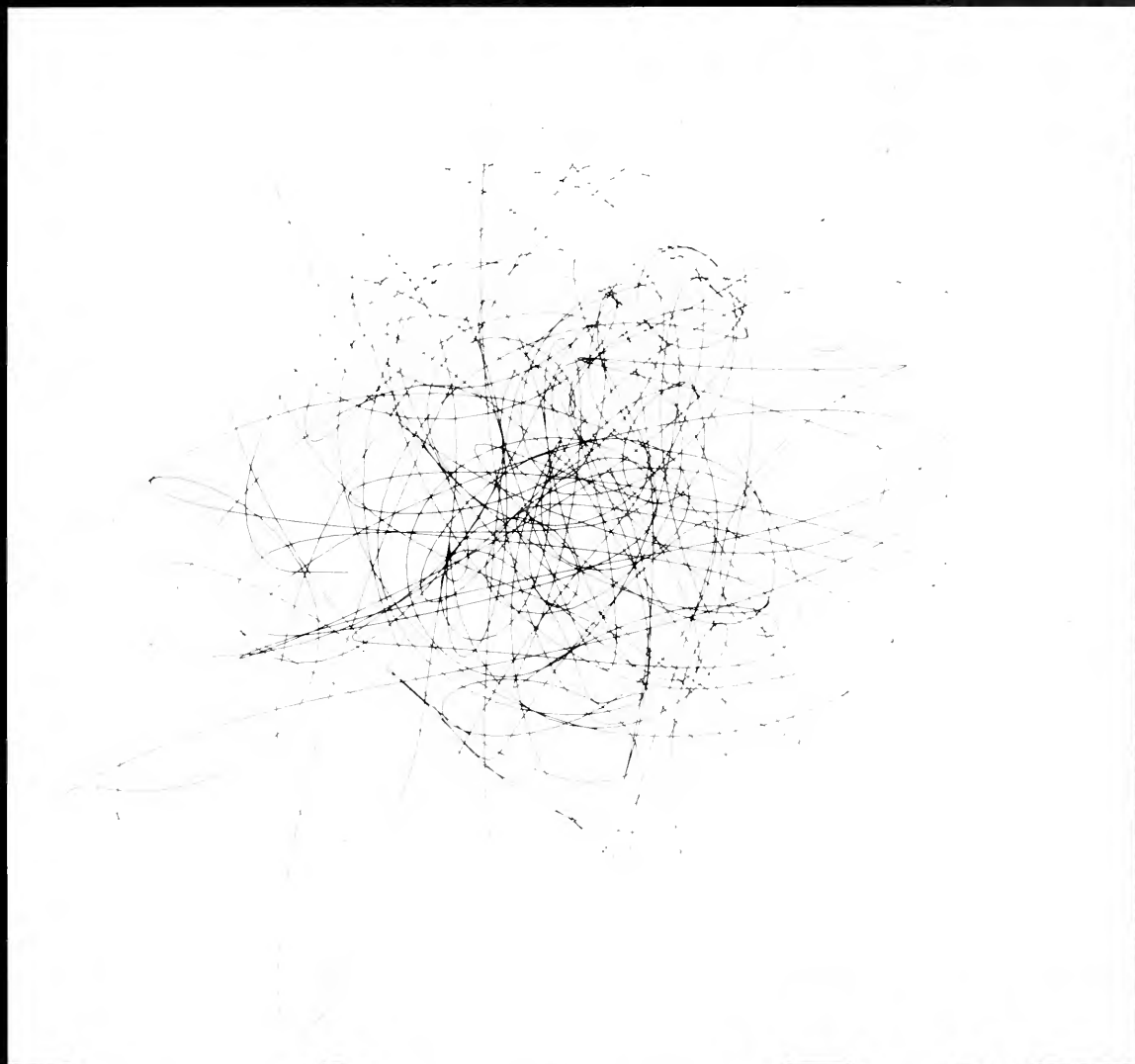

When a sound tone is transmitted in the deep sound or SOFAR channel, it travels to the receiver along many different paths, each with a slightly different travel time. The travel times vary because of random variations in those factors that affect sound velocity — temperature and salinity. The signal that results from the sound tone is the sum of all the multi-path arrivals. It, too, varies randomly. This diagram is one way of depicting the random variations of the received signal. It is a similar pattern to the random motion of a gas molecule, or what physicists call “Brownian in motion.” If an origin is imagined at the center of the figure, the length of a vector from the origin to any point on the random lines represents the amplitude of the signal at a given instant of time. The angle the vector makes with the horizontal represents the phase of the signal. (Adapted from Freeman Dyson, Walter Munk [who calls the diagram ‘Random Walk’], and Bernard Zetler, *The Journal of the Acoustical Society of America*, vol. 59, p. 1121, 1976)

UNDERWATER ACOUSTICS IN MARINE GEOLOGY

Or How to Study the Ocean Floor Without Actually Going There

by George G. Shor, Jr.

All that water gets in the way . . .

When a geologist goes to the field to map in a subaerial environment (that minor part of the earth that protrudes above sea level), his most important mapping tool is a pair of stereoscopic multispectral optical sensors — his eyes. He can determine spatial relationships, textures, colors, shapes, and, with a few simple accessories, distance, sizes and elevations. These sensors, however, do not work well for the larger portion of the earth that is under water; the geologist can either “color it blue” and forget it, or use other forms of “remote sensing,” particularly underwater acoustics.

Underwater sound is not an ideal tool for mapping, locating oneself, or just plain “looking.” The wavelengths are generally too long for observing fine details, the velocity varies more than one would wish, and worst of all, the ray paths are not quite straight. Still, it works, and as the old saying goes: “crooked or not, it’s the only game in town.”

How deep is the ocean . . . ?

The first thing we need to map surface geology is a topographic base map. The first order of business for the marine geologist, therefore, is to measure the depths of the ocean. One could do it with a wire line (and ingenious ways were found to do this in the 19th century), but to obtain a sounding for every square kilometer in the ocean (assuming 2 hours per sounding, which is fast) would take 80,000 ship-years, not counting time for port stops or breakdowns. There must be a better way. If one could only avoid those stops to lower the wire, the job could be done in only about 2,000 ship-years! The “better way” is echo sounding. (“Sounding”

originally had nothing to do with sound; one can “sound” with a rope or wire. It is an old nautical term, meaning “to measure depth.” Ships’ engineers “sound the tanks” with a steel tape measure to find out how much fuel is left.) To take an echo sounding, in its simplest form, one needs only something that makes a short pulse of sound (a bomb, a sledgehammer against the ship’s hull, or a modified loudspeaker), a listening device, and a stopwatch. Make a noise, start the watch, note down the time when the echo returns, and do it again. And again and again and again . . .

Relatively crude sounding systems showed the presence of some of the most spectacular features of the oceans — the mid-ocean ridges, the great trenches, the continental shelves. The addition of graphic recorders to the echo sounder revealed more features — thousands of volcanic peaks, some with their tops mysteriously flattened at depths far below present sea level (“guyots,” discovered by Harry Hess during World War II), and long, straight, parallel troughs, ridges, and escarpments (fracture zones) discovered by H.W. Menard and Robert Dietz in the eastern Pacific.

A great improvement was made in the mid-1950s when the basic echo sounder was married to the facsimile recorder, previously used for transmitting pictures and weather maps by wire and radio. A facsimile recorder produces a dark spot on a roll of electrosensitive paper whenever an electric signal is sent. To keep the picture in proper form, an accurate timing signal (as in a modern TV system) is used to synchronize transmitter and receiver. These recorders, with timing precise to better than one part in 100,000, revealed new and

surprising features about the ocean floor.

With the Precision Graphic Recorder (PGR), developed at Woods Hole Oceanographic Institution, and the Precision Depth Recorder (PDR),* developed at Lamont-Doherty Geological Observatory in New York, large areas of the ocean floor were found to be smooth planes that had slopes less than one part in a thousand, flatter than any "plain" on land, but still sloping steadily from the foot of the continental slope down into the basins against the rough mid-Atlantic Ridge. On these "abyssal plains" were additional smaller scale features: sinuous ridges and troughs a few meters high and deep, closely resembling the river valleys and natural levees found in terrestrial streams on flood plains. The only reasonable explanation — since confirmed by coring and drilling — is that the abyssal plains are indeed giant flood plains, over which sediment from land is carried through the distributaries, overtopping the natural levees and dropping the sediment load to produce each time a few more millimeters of sediment on the abyssal plain.

Very precisely wrong . . .

The precision echo sounder measures travel times of the echoes as precisely as one can reasonably wish: to at least one part in 10,000; better if the bottom is hard and the recording scale expanded. We do not really want to know the travel time, however; what we are after is the depth. To do this, we need to know the velocity of sound in seawater. Not just in average seawater, but in the water at the actual place and time of the sounding. Since the speed of sound in the oceans can vary by several percent — depending on the temperature, salinity, and pressure — this would seem to wreck the whole system. We are saved, however, by the relative stability of the oceans. While the temperature (and therefore the velocity) in the surface layers of the ocean changes quite a bit with the season, the year, the weather, and even the time of day, temperature measurements in the deepest water can be reproduced to a few hundredths of a degree from one decade to the next. One can, therefore, calibrate

**The PDR uses dry electrosensitive paper with a paper speed of 60 centimeters per hour. It displays 400 fathoms over a width of 47.12 centimeters. It phases automatically so that depths to the full range capability of the sonar set can be recorded in increments of 400 fathoms. It also triggers the sonar set and performs the time-measuring function. The PGR is similar, but it is considered to be more versatile because it has many scale and depth combinations readily available. Whereas the PDR uses a stylus for recording, the PGR uses wet recording paper and helix. A large number of similar recorders have since been developed.*

the echo sounder record by deriving average temperature, salinity, and velocity curves for large areas of the ocean.

The British Admiralty issued (in 1927; revised in 1939) a set of very useful tables of the average "sounding velocity" in each major portion of the oceans. Some early echo sounders had adjustable sweep speeds so that the correction could be made automatically. Unfortunately, human error crept in: sometimes the sounder was set to the wrong velocity, and other times the velocity used was not noted. The velocity is a nonlinear function of depth anyhow, so any calibration is only an approximation. The more common procedure has been to adopt a "nominal velocity," either 800 fathoms per second, which is a bit on the low side, but a nice round number, or 1,500 meters per second, which would correspond to 820.2 fathoms per second (about right for deep water in temperate climates). Most charts are made in "uncorrected fathoms" or "uncorrected meters," and the corrections can be added later. They are small if one uses the metric base (but significant, if one is cutting wire for a taut-wire mooring); they are a bit large when one uses the nominal fathoms.

Getting closer to the subject . . .

The precision echo sounder, useful as it is, begins to fail us when the water is deep and the bottom rough. Problems arise because of compromises necessary in the design of deep-sea sounders. All ships roll and pitch — oceanographic ships, regrettably, are not exceptions. If an echo sounder has a very narrow beam (obtainable only by going to a very large array of transmitting and receiving elements, or to high frequencies), the beam would be pointing at the bottom only a small fraction of the time. So, most echo sounders have a beam of about 30 degrees, so that even for a roll of 15 degrees in either direction, some of the sound would still be directed toward the bottom. Unfortunately, it can also receive echoes from directions other than straight down, and therefore records echoes from any point on the bottom that has either a plane surface perpendicular to the arriving sound ray, or a sharp corner that can diffract the energy back. It produces a complex pattern of returns that is directly related to the shape of the sea floor, but is not exactly a cross section (Figure 1). The greater the distance to the sea floor, the worse the situation becomes, because a larger and larger area of the sea floor is "illuminated" by the sound in deep water. In shallow water, the area of illumination — even with a wide-beam sounder — is small, and the echogram is closely related to the true shape of the bottom.

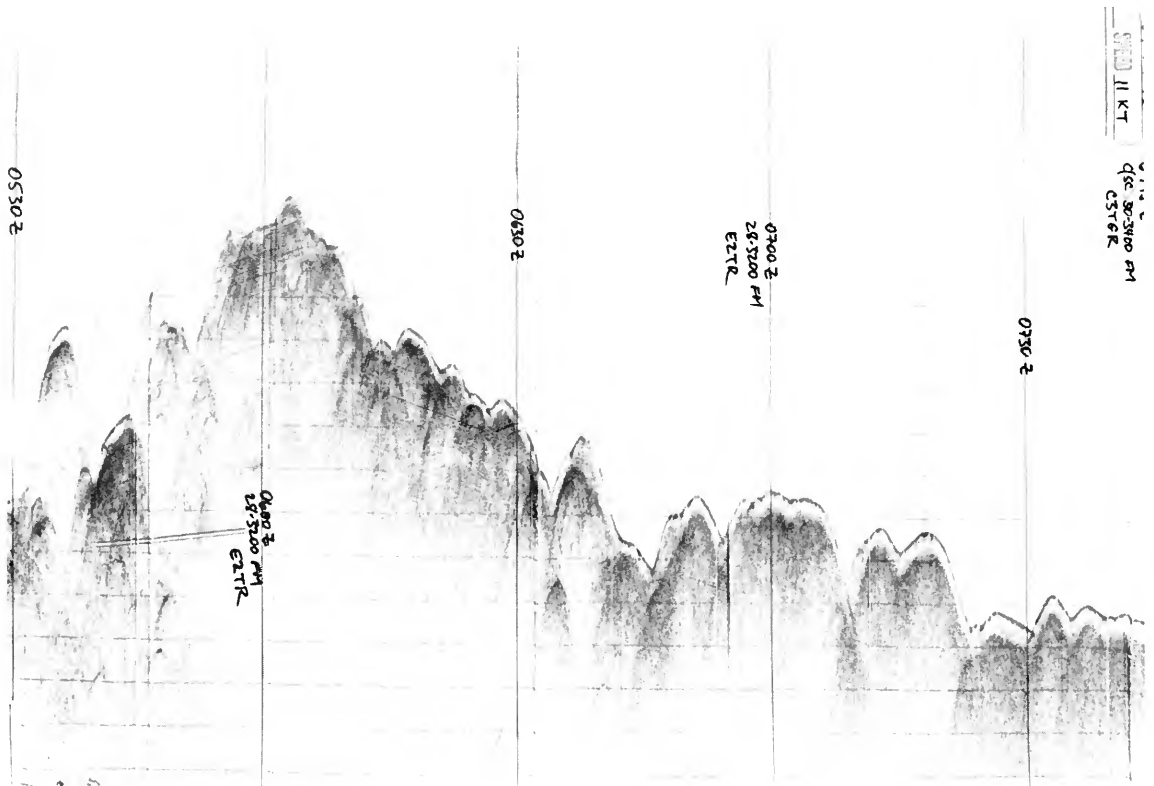

Figure 1. Echo sounder record (3.5 kilohertz operating frequency; recorded on a Giffi Depth Recorder) from the northeastern Pacific in an area of abyssal hills. The depth represented by the upper edge of the record is 2,800 fathoms (5,250 meters); the lower edge of the figure would be 3,200 fathoms (6,000 meters). The sea floor does not really consist of rounded domes as this record suggests; sound waves diffracted from sharp peaks produce "hyperbolic echoes," which conceal the true shape of the sea floor. (Courtesy Scripps Institution of Oceanography)

An obvious — but in engineering terms not so simple — solution to the problem is to turn the deep-water problem into the simpler, shallow-water problem. Take the echo sounder, put it on a long cable, and tow it close to the bottom. Use an upward-looking echo sounder to determine the instrument depth, and a downward-looking echo sounder to map the sea floor. Now all of the bottom features are sharp and distinct. The first few surveys using such a "Deep-Tow" system — developed at the Marine Physical Laboratory at Scripps Institution of Oceanography in California — showed that the ocean floor is much more complex than surface soundings suggested. Linear ridges, vertical cliffs, and sand dunes are not uncommon. To use this fine-scale information, however, something new had to be added: precise navigation of the towed echo-sounder system, which is rarely directly behind the ship that tows it. The solution to the navigation problem is more acoustics (see page 22). Battery-powered acoustic transceivers are dropped

to the sea floor in the survey area, where each in turn can be interrogated by the deep-towed acoustic system. The arrangement of the equipment is shown in Figure 2.

If you look at it from a different angle . . .

If one is to see trends and lineations in the ocean floor (or look for lost objects), looking straight down is not the way to go. True, some echoes come in from one side or the other, from objects protruding above the general level of the sea floor. Not only is there an ambiguity about which side these objects are on, but the picture is not very clear. If one could only tilt the system on its side. . . ! One can, of course. It takes more power, and the record does not look quite the same. Ideally, the outgoing signal should be focused in a narrow beam fore-and-aft to prevent blurring of the picture, and in a broad beam up-and-down to cover areas well out to the side. Then, the first echoes in each sweep can be treated

as coming from below the track of the ship (or of the towed sonar), and the late echoes from far out to the side. If the beam is narrow enough, each sweep covers a slightly different strip of the bottom, and the composite record resembles an air photo. There is still a bit of blurring, however, because of the finite beam width of the sonar signal. Unless one has a nonlinear sweep rate in the recorder, the distance across the record is not exactly proportional to the distance either side of the ship's track. Figure 3 shows a pair of records (the upper portion is the return from the right of the instrument and the lower from the left) from side-looking sonars on the Deep Tow instrument. It is being towed along the zero line.

The usual depth recorder (PDR, PGR, etc.) records signals as a darkening of an originally white piece of recording paper; this does not seem odd in an instrument that is set up to record water depth; we have nothing familiar with which to compare it. The side-scan record, however, looks so much like an air photograph that the difference in appearance becomes disconcerting. "Highlights" are, of course, dark; "shadows" are light areas. So the presence of a white patch in the record means that there is something in front of it, and the white patch is a shadow zone. This can be corrected by printing a negative instead of a positive print.

Now that we've got the water out of the way, what about the mud . . . ?

As mentioned before, echo sounders are engineering compromises. Water is not a perfect medium for transmission of sound, and there is some loss of energy even in distilled water. The losses are greater in seawater than in freshwater, and higher proportionately at higher frequencies. Sound transmitted in the wrong direction is wasted, so one wants a narrow, transmitted beam (within the limitations set by the ship's roll). Noise comes from all directions, so that the signal/noise ratio is improved by having a narrow listening beam. To get a narrow beam requires sending and receiving "transducers" that are several wavelengths across. The lower the frequency, the longer the wavelength, the larger the transducer for a given beam width, and the bigger the hole that one has to cut in the ship's hull to accommodate the transducer. For these reasons (and for others that are strictly historical accident), most deep-water echo sounders used on American ships work at a frequency of 12 kilohertz (kHz). At this frequency, losses in the water are relatively small, and a 30-degree transducer will fit into a relatively small hole in the ship's hull. The mud at the bottom of the ocean, however, is another

KEY

- | | |
|-----------------------------------|----------------------|
| 1. DOWNWARD LOOKING ECHO SOUNDER | 5. STROBE LIGHT |
| 2. 3.5 kHz 'P' BOTTOM PENETRATION | 6. CAMERA |
| 3. UPWARD LOOKING ECHO SOUNDER | 7. MAGNETOMETER |
| 4. ACOUSTIC TRANSPONDER | 8. SOUND VELOCIMETER |
| 9. SIDE LOOKING SONAR | |

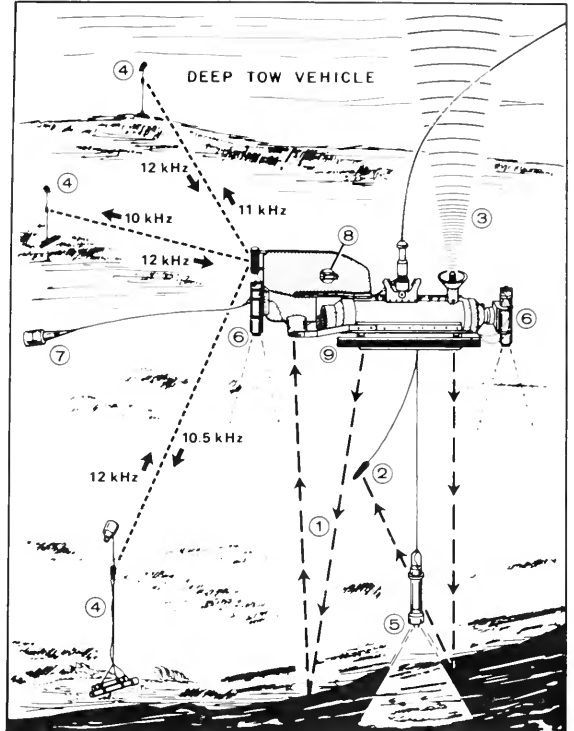

Figure 2. Transponder-navigation and echo sounding systems on the Scripps Institution of Oceanography's Deep Tow vehicle. (Courtesy Peter Lonsdale and Fred N. Spiess, Scripps Institution of Oceanography)

matter. In silty sediments, at 12 kHz, the signal strength drops by half in less than 5 meters. Because of this, the normal echo sounder cannot tell us very much about internal structures within the sediments of the ocean floor, and tells us nothing about the hard rocks below.

Given the rest of the technology of echo sounding, however, a simple solution is to lower the frequency of the sound source. By dropping the frequency down to 3.5 kHz, one obtains a signal that can penetrate 30 meters into a mud bottom before the signal strength drops by half. Not as good as one would like, but enough to disclose internal structure within the sedimentary section. One would like to go lower yet — and the frequency could be dropped some more. To get really deep penetration, however, frequencies need to be much lower, by a factor of 100 or more. As a result, systems for examining structure within the sediments of the deep sea, and

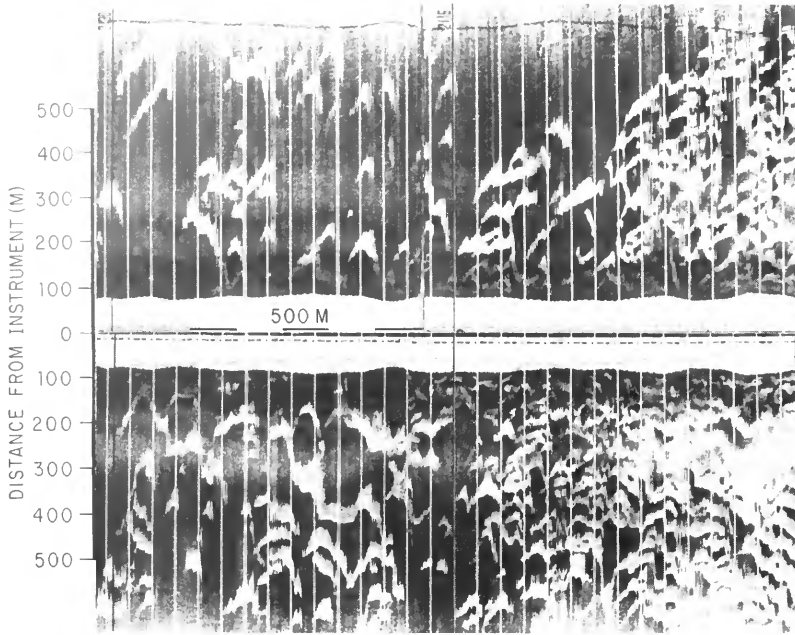

Figure 3. Side-looking sonar record of sea-floor dunes on the Carnegie Ridge off the coast of Ecuador and Peru. The boundaries between light and dark areas near the center of the record are the sea-floor profile directly beneath the instrument; the lower and upper parts of the record represent the sea floor to the left and right of the instrument track. (Courtesy Peter Lonsdale and Fred N. Spiess, Scripps Institution of Oceanography)

for studying the surface of the basement rock below, usually operate below 40 Hertz (Hz), where the penetration can be a kilometer or more.

Seismic profilers: unsound sound . . . ?

When we get down to frequencies around 32 Hz (about 3 octaves below middle C), and especially when we talk about seismology, there is some question as to whether we are dealing with sound anymore. One dictionary states that sound is "that which can be heard." By this definition, a 32-Hz vibration may be sound to you, but it is not sound to me because I cannot hear it. The hearing of most persons drops somewhere in this region, and by the time that one gets down to frequencies on the order of 16 Hz (4 octaves below middle C), it is not really sound by this definition. Another definition that is perhaps better for our purposes is also in the dictionary: "mechanical radiant energy that is transmitted by longitudinal pressure waves in air or other material medium and is the objective cause of hearing." Seismic waves by this definition include sound waves — and a lot more. Perhaps the only good distinction is that acousticians work with sound, and seismic waves are for seismologists. Seismic waves, which are produced by earthquakes, generated by explosions, or used in seismic

profilers, include not only compressional waves that at higher frequencies are called "sound," but also vibrational forms — such as shear waves, Rayleigh waves,* Love waves,** and a number of others — at frequencies that can go as low as a few millihertz (one millihertz is 3.6 cycles per hour!).

The seismic profiler, the "echo sounder" that penetrates sediments as well as water, borrows from acoustics and seismology, using a low-frequency "sound" source with an echo sounder recorder to map reflections from below the sea floor.

A variety of sound sources are used for reflection profiling — high explosives,

*Named after John William Strutt, Baron Rayleigh, the "patron saint" of acoustics. If you look on the bookshelf of any acoustician, you will probably find a copy of Rayleigh's *Theory of Sound*, first published in 1877. A Rayleigh wave is an elastic wave that travels along the surface of a solid medium, such as the earth; the particles move in a retrograde elliptical orbit, with the plane of vibration coincident with the plane of propagation.

**The Love wave was named for A.E.H. Love, an English mathematician, and refers to a type of seismic shear (transverse) wave that travels near the surface of a multilayered solid medium. Rayleigh and Love waves are generated in copious amounts by earthquakes but not by acousticians, and can be used to determine average structure over large areas of the earth.

propane-oxygen mixtures, electric sparks, steam bubbles, compressed air, hydraulically-actuated plungers, mechanical vibrators, and conducting plates forced apart by eddy currents. All have advantages and disadvantages. The most commonly used sound source today is the compressed-air sound source, commonly called an "airgun." The airgun is simple in concept; it consists of a fast-opening valve, which quickly discharges a large volume of high-pressure air into the ocean below the surface. One type of airgun uses an electrical control signal, which operates a solenoid to trip the valve. The other commonly used type depends on a balance between a sealed internal air chamber, and the pressure in the operating chamber that is charged from a shipboard air compressor. (It is a pneumatic analog of a free-running multivibrator in electronics.) In the first case, the recorder triggers the airgun; in the second case, the sound signal from the airgun actuates the recorder. Air pressures are generally of the order of 1,800 psi, and air volumes can vary from 5 to 300 cubic inches (80 milliliters to 5 liters).

When the air bubble is released into the water, its internal pressure is much higher than the ambient pressure in the water around it. Some of the energy in the bubble is transformed into a shock wave, sending out an acoustic signal in all directions. The remainder of the energy expands the bubble until finally it has passed far beyond its equilibrium size, and contains a partial vacuum. At this point, the bubble collapses. The water rushes in, and again equilibrium is passed; the bubble is reduced to a small size, the air compressed again, and the explosive expansion is repeated with another shock wave transmitted. The fundamental frequency transmitted by the airgun is determined by the rate at which the bubble expands and collapses, a rate that is inversely proportional to the cube root of the energy in the initial bubble, and directly proportional to the water pressure at the depth of the bubble.* (This relationship, the Rayleigh-Willis equation, dates back to Lord Rayleigh listening to the noise made by a boiling teakettle.) It does not seem like a very efficient way to produce a sound, and indeed the efficiency of an airgun is much lower than that of a block of TNT (but higher than that of a loudspeaker). Efficiency is not everything! The airgun does, however, have a great advantage over many competing sound sources in concentrating its energy output in a relatively

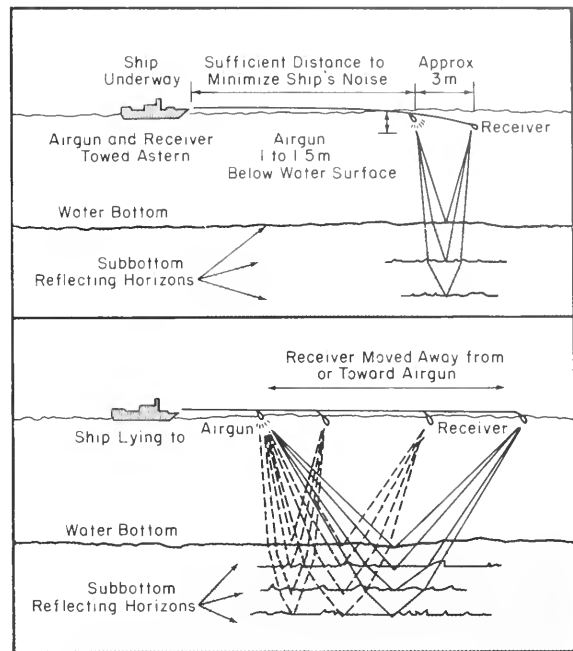

Seismic profiling of sub-bottom sediments utilizing airgun. (Adapted from Oceanology by Dale E. Ingmanson and William J. Wallace, © 1973 by Wadsworth Publishing, Inc. Reprinted by permission)

narrow band at low frequency. Good on the low notes, but not too good on the high; if you want higher frequency signals, try a spark gap. Some groups play several airguns of different sizes in synchronization, like a tympani section, or combine an airgun or two with a few spark gaps and a 3.5 kHz echo sounder for real broadband orchestration.

Airguns, sparkers, and other low-frequency sound sources are usually not directional. As noted earlier, echo sounders must have a source (or array of sources) several wavelengths across to get appreciable directionality. Since the wavelength of sound equals the speed of sound in the medium (in this case, water with a speed of 1,500 meters per second) divided by the frequency (about 30 Hz), a wavelength would be 50 meters. An array several wavelengths in diameter would be longer than most oceanographic ships, and many times as wide. What airguns lack in directionality, however, they make up in power.

The signal processing and recording system can be very similar to that used in an echo sounder, although the filter frequencies are different. The detector system is more awkward, however. Ships are fairly noisy at these low frequencies, and a simple, hull-mounted receiving system cannot achieve the low noise levels needed for reception of

*Actually, to $(H + H_0)^{5/6}$ where H is the depth of the airgun below the water surface, and H_0 is atmospheric pressure expressed as equivalent water depth.

the weak echoes from within the sea floor. As the systems evolved, they converged on a similar configuration — a large number of small hydrophones, designed to be insensitive to “self-noise” produced by their own motion in the water, immersed in an oil bath inside a long hose. The hose, balanced for almost neutral buoyancy, is towed some hundreds of meters astern of the ship, and preferably out to one side to avoid the ship’s wake. Because of its length, the receiving streamer has some directivity fore-and-aft; if two streamers are towed port and starboard, one gains a little directivity side-to-side, but not much. The airguns are usually fired at intervals of 10 seconds or more (as compared with one-second intervals on most echo sounders); it takes awhile to pump up the air, and the returned signals take longer to die away.

Let’s look at the record . . .

When we discussed the simple echo sounder, the statement that sound waves are reflected from the sea floor was implicitly accepted without asking why. As Rayleigh showed many years ago, the phenomenon that we know as “reflection” is part of a conversion process that occurs whenever sound (or light, or other forms of wave motion) encounters a change in the medium in which it is moving, involving either the propagation velocity or the density. Some of the energy is transmitted into the second medium; some returned (reflected) to the first medium. If the direction of arrival of the signal is not exactly perpendicular to the interface, and if either medium has some rigidity (unlike water), some of the energy can also be transformed into shear waves and surface waves in one or both media. When a sound wave (a compressional wave) does arrive on a path perpendicular to the interface, part of it is reflected, and the rest continues into the second medium; the amplitude of the signal reflected is proportional to the differences of the products of density and sound velocity on the two sides of the interface,

$$\frac{A_{\text{reflected}}}{A_{\text{incident}}} = (\rho_2 V_2 - \rho_1 V_1) / (\rho_2 V_2 + \rho_1 V_1).$$

Continuing down into the sediments, the signal returns small echoes whenever it encounters more locations where velocity or density increases or decreases abruptly; at each such change, another echo is returned. In Figure 4, a typical record is shown, with many echoes from layers beneath the sea floor. If the position of the contrast is a smooth surface (such as a depositional layer), the returned

signal will be in almost the same location on the record in successive sweeps of the recording stylus, and a line will be formed on the record. There also will be random spots of record darkening, due to either returns from small blobs of contrasting material, or to noise in the system. The human eye does an excellent job of distinguishing linear patterns, however, and the lines due to layering show up strongly on the record if the recording sweeps are close together.

The style of recording in most profiler systems does not permit quantitative measurements of the strength of an echo; however, one can tell something from the approximate darkness of the trace (if knob-twiddlers can be restrained from making adjustments too frequently). Some information is also obtained from the presence or absence of closely-spaced reflectors. Continuous, uniform sedimentation produces a “transparent” layer that has no apparent internal layering; turbidites (sediments laid down by turbidity currents, as on the abyssal plains) have numerous, strong, closely-spaced reflecting layers. Faults can sometimes be identified by the termination or displacement of recognizable strong reflectors (although in nearly every case, the end of the reflector is not shown as an abrupt end of the reflection, but has a downward bending “diffraction pattern” beyond the real end point).

A rough surface, such as a lava flow, does not generally produce a smooth, continuous reflection like a sedimentary horizon. Strong echoes are returned over a wide range of angles from peaks and troughs on the rough surface, while the side slopes return little, if any, energy. Each such “highlight,” then, produces an umbrella-shaped diffraction pattern, the peak of which represents the position of the highlight. The basement interface can usually be recognized by this scalloped pattern. Deeper interfaces, within the igneous rocks of the crust, do not usually return easily recognizable echoes on standard airgun profilers; more complex methods are usually required to get information about these deeper rocks.

We asked for depth, and you gave us time . . .

The usual record from a reflection profiler, like the record of an echo sounder, shows travel time rather than depth. The conversion velocity in this case, however, is not a uniform value that can be taken from tables for large areas of the oceans, as in the case of the water layer. One cannot separate out the velocity from a “normal incidence” record, where the sound source and the detector streamer are side

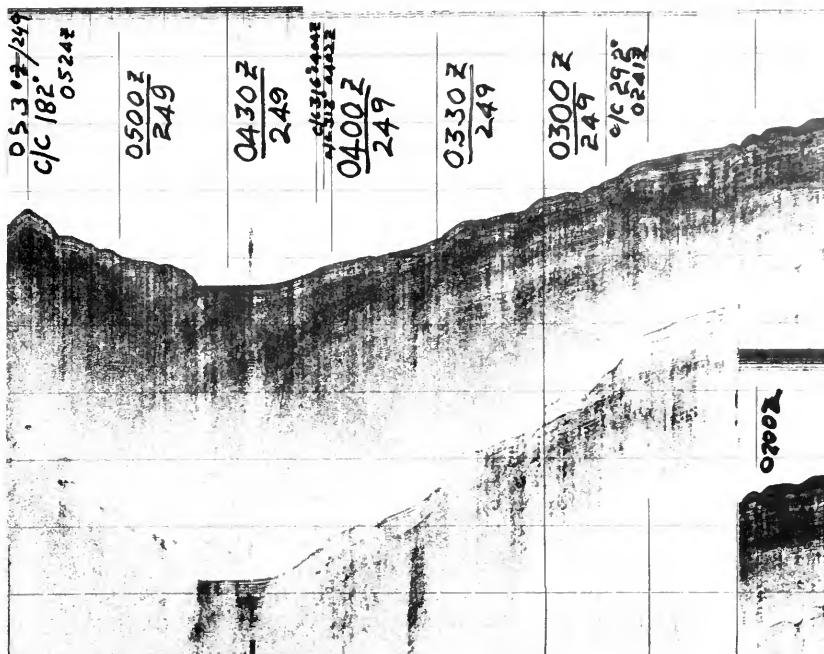

Figure 4. Reflection record taken across the bottom of the Timor Trough, north of Australia. The record was obtained using two large airguns and one single-channel hydrophone streamer; no "automatic gain control" or other processing. Note the faults and folds in the sediments dipping down toward the bottom of the trough, and the flat-lying sediments on the floor of the trough. The strong reflections in the lower part of the record are multiples (sound reflected once from the sea floor, once from the sea surface, and again from below the sea floor). (Courtesy Scripps Institution of Oceanography)

by side. If one separates the two by a distance that is a significant fraction of the depth, however, one can solve for both the travel time and the average velocity, and obtain the depth to a reflector. The average velocity, of course, will be different for the various reflections on the record. If the reflecting layers are horizontal, and if one records the reflection time when the airgun is directly alongside the detector, and again when they are separated by a horizontal distance "x," and if

T_0 is the travel time at normal incidence, and

T is the travel time on a slant path,

$$(V_{av}T)^2 = (V_{av}T_0)^2 + x^2, \text{ and}$$

$$V_{av} = x / \sqrt{T^2 - T_0^2}.$$

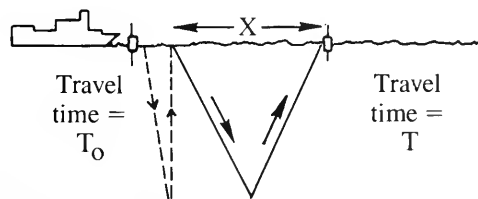

The world is not made of horizontal layers of material of constant velocity, of course, but one can obtain a reasonable approximation of the true velocity in each layer if one corrects for the dip of the layers, and repeats this "wide-angle" calculation

for many reflections and at many locations. Usually, a streamer is not long enough, so we use the sonobuoys that have been developed for acoustic work. We steam away from the sonobuoy, operating the airgun and recording the radio signal that comes back from the abandoned buoy.

Noise is a signal you don't want . . .

When the signal from a seismic profiler comes back to the water surface, it does not just go away. Most of the signal (more than 99 percent) is inverted, and reflected back into the water, to make another trip to the bottom, and be reflected again, return again, and so on for many, many trips depending on how "hard" (acoustically) the bottom may be. As many as 20 round trips have been recorded in areas of very hard sea floor; two or three such "multiple reflections" are frequently observed. One such "multiple" is visible in the lower part of Figure 4. In this illustration, the multiple reflection comes in after all of the data from the deep sub-bottom reflectors have been recorded. If, however, we had better penetration on this record, and wished to see deep reflections that arrived at the same time as the multiple, we would have a serious problem. As can be seen in Figure 4, the time from the top of the record to the beginning time of the multiple is exactly twice the time to the beginning of the "real" bottom reflection. If the water were shallower, the

multiple would begin closer to the real reflection. In very shallow water, the multiple reflections are usually so strong and close together that little information can be obtained from a seismic profiler.

Multiples can be eliminated from the record, but only with difficulty. The most direct way is to use a long streamer, use variable delays in the signals from the various hydrophone groups along the streamer, and add the signals together. If one uses delays that are appropriate to the true average velocity between the sea surface and the deep reflections, the multiples will be a little bit "out of phase" when the signals are added, and they will be suppressed, while the "true" signals are reinforced. Using such a long streamer is expensive and difficult, but fringe benefits, in addition to the reduction of multiples, include frequent determination of velocities, reduction of other kinds of noise, and effective increase of the apparent power of the sound source. Such long arrays, recorded digitally, have been in use for some time in commercial geophysics. They are just beginning to be common in oceanographic geophysics.

How can we get deeper yet . . . ?

When reflection methods fail we must return to the crooked ray paths. If a sound ray (or a light ray) encounters a discontinuity where the velocity changes (please note that density is not directly involved here), and if the ray is not perpendicular to the interface, the part of the energy that goes through the discontinuity does not continue in the same direction as it did before. Instead, it is bent farther away from the line perpendicular to the discontinuity. This is commonly observed with light rays — it is, in fact, the reason that prisms and lenses focus light. Snell's law, which defines the relationship, says that $(\sin \theta)/V$ is a constant, where θ is the angle with the perpendicular at each interface, and V is the velocity of sound in the medium on the same side of the interface that the angle is measured.

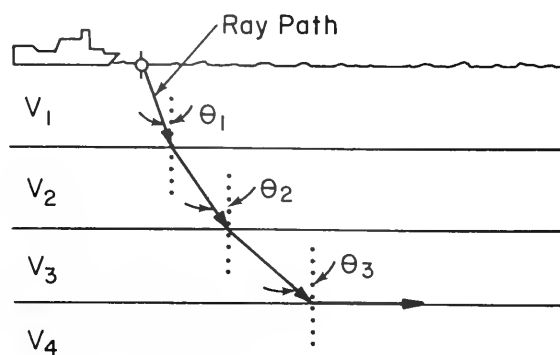

If, then, the sound ray starts down from the source at a small angle from the vertical, and the velocity in deeper layers becomes greater and greater with depth, the ray will be bent toward the horizontal. If velocity varies continuously with depth, nearly every ray (except the steepest ones) will reach its "ultimate depth," at which its path becomes horizontal, and the sound starts back up toward the surface, following a path that is the mirror image of the one it followed on the way down (if all of the layering is horizontal). If the velocity is constant in each of a series of layers, with large jumps in velocity from one layer to the next, fewer rays will find a depth at which they become horizontal, but a little energy will always travel along the interface, and leak back up to the surface. The returned signals are weak, but detectable, and provide the signals for seismic refraction surveying.

Seismic refraction surveys require a sound source, a receiving hydrophone or seismometer (a seismometer measures motion rather than pressure), and a timing system. The arrangement is different from that used for the usual reflection survey, however, because source and receiver must be far apart. Usually, the source-receiver distance needs to be at least five times the depth from which one wants data. One therefore sets out receiving hydrophones or seismometers, and goes away operating the sound source at greater and greater distances. For short runs and shallow penetration, an airgun can serve as a sound source. For deep penetration, explosives are usually required. The frequencies are even lower than in reflection work — usually about 4 to 20 Hz — because they have long paths to travel through the sea floor and the high frequencies are quickly removed by absorption. The hydrophones or seismometers have to be extremely quiet to pick up the weak signals. One can use individual quieted hydrophones, fastened by cables to one oceanographic ship, while a second ship steams away dropping shots. Alternatively, one can modify sonobuoys for quieter operation, and a single ship can carry out a refraction profile, receiving the signals by radio from the sonobuoys. Moored buoys with built-in recorders also have been used, as have ocean-bottom seismometers, which are dropped to the sea floor before the shooting run, and recovered when the run is completed.

The returned signals, however obtained, are usually recorded as "wiggly-line" records on an oscillograph. Arrival times of sound waves are read off the records, and plotted as a "travel-time" plot against distance between shot and receiver. Figure 5 shows a travel-time plot, which can be used to calculate seismic wave velocity as a function of

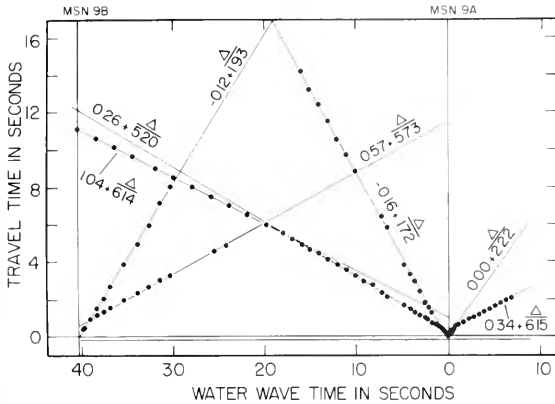

Figure 5. A typical refraction travel-time plot; this is for a station on the continental shelf north of Australia. (Courtesy Scripps Institution of Oceanography)

depth below the sea floor. With such methods, we have mapped the geological structure down to the base of the crust (about 11 kilometers beneath the oceans; as much as 40 kilometers below the edges of the continents). Current experiments are measuring far deeper structure, using large explosive charges and much longer distances from shot to receivers.

What next . . . ?

The future of acoustics in marine geology seems to be going in two directions. Multi-channel digital seismic reflection systems are being used by more and more marine geologists to obtain details of structure in the complex areas along the ocean margins, and to attempt to make reflection measurements within the crystalline rocks. Seismic refraction work is becoming more common, after a period of neglect, and is being used for deeper penetration into the mantle. In both cases, digital methods are replacing the analog systems used in the past, and a great deal more "data processing" is taking place between the signal detection and interpretation by the geologists. Life is no longer simple, and what's more, it never was.

George G. Shor, Jr. is a professor of marine geophysics in the Marine Physical Laboratory of the Scripps Institution of Oceanography, La Jolla, California. He has been involved in seismic reflection and refraction work at sea since 1953, with occasional time out for administrative work as Associate Director of the Scripps Institution of Oceanography.

Suggested Readings

- Hampton, L., ed. 1974. *Physics of sound in marine sediments*. N.Y.: Plenum Press.
- Hill, M., ed. 1963. *The sea*. Vol. III. N.Y.: Wiley-Interscience.
- Keen, M.J., ed. 1968. *An introduction to marine geology*. N.Y.: Pergamon Press.
- Maxwell, A., ed. 1970. *The sea*. Vol. IV. N.Y.: Wiley-Interscience.



acoustic behavior of sperm whales

by **william a. watkins**

No other whale has excited as many dreams or inspired as many tales of adventure as the sperm whale (*Physeter catodon*). They were the whales most hunted during the glamorous days of whaling under sail, and popularly represent the whole whale family. But we still know very little about them, other than that they are deep-water whales (usually not found in less than 1,000 meters), and that they come to the surface to breathe.

From the anatomical statistics of whales caught by modern whalers, we do know quite a lot about their bodies, but when it comes to their

behavior we are largely ignorant. They breathe at the surface — basking in the sun for 1, 2, or 10 minutes — then disappear and often are not seen again. We rarely are sure that we have seen the same animal twice. All we know of their underwater existence is that they can dive deeply (some have been entangled in submarine telephone cables), catch mostly squid as food, and that they produce underwater sounds.

Underwater whale sounds were first noticed by whalers who sometimes heard grating noises through the air and through the bottoms of

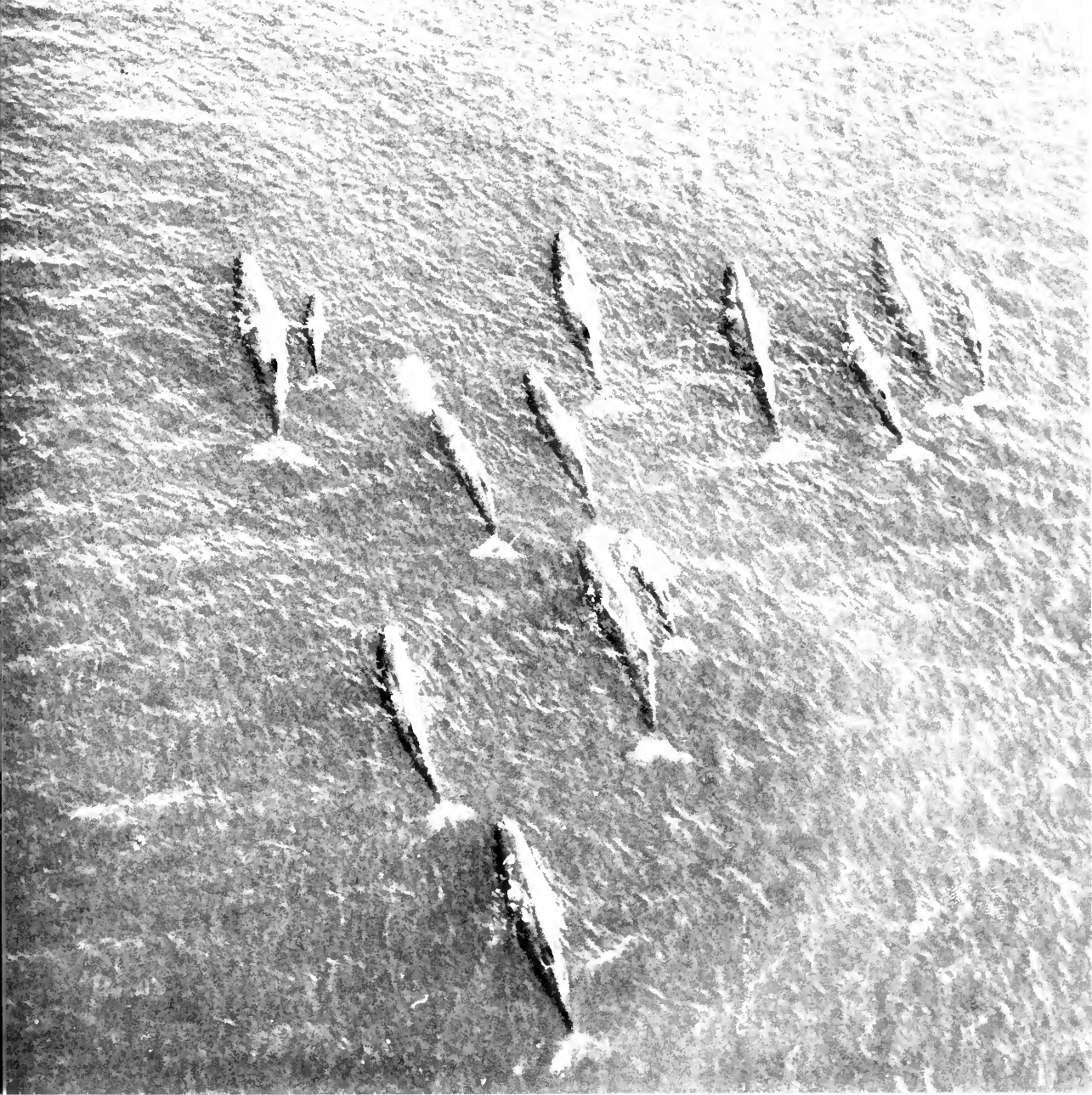

An aerial view of 21 sperm whales, including two young calves and several large males, off Japan. (Courtesy T. Kasuya, in Whales, Dolphins, and Porpoises of the Western North Atlantic, by S. Leatherwood, D. K. Caldwell, and H. E. Winn, NOAA Technical Report NMFS Circ-396)

their boats, but it was the wartime experiences of underwater sonar operators in the 1940s that emphasized the variety of underwater sounds associated with whales and porpoises. Then in 1948, William Schevill of the Woods Hole Oceanographic Institution and Barbara Lawrence of the Museum of Comparative Zoology at Harvard University recorded the underwater sounds of the white whales (*Delphinapterus leucas*) in the Saguenay River, Quebec. This began the scientific investigation of whale sounds. In the next few years, the sounds of several of the smaller cetaceans were studied,

including their hearing and echolocation* capabilities.

The first description of sperm whale sounds came in 1957. L.V. Worthington, currently Chairman of the Department of Physical Oceanography at the Woods Hole Oceanographic Institution, encountered five whales in the course of

**The emission of sounds by an animal, such as a bat, to orient itself and avoid obstacles, especially in darkness. The sounds are reflected back and thus indicate the relative distance and direction to objects.*

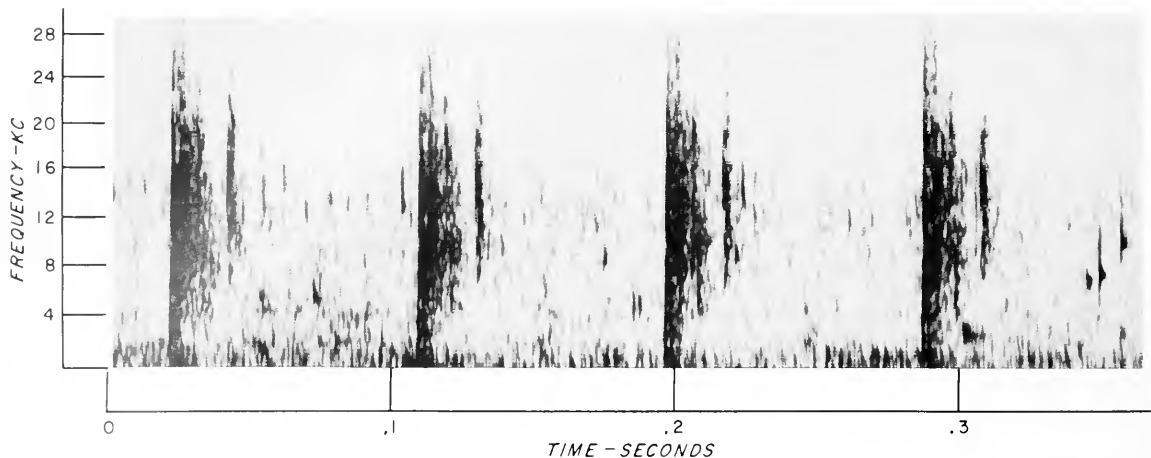

Figure 1. The broad spectrum of clicks from a nearby sperm whale shows a higher-frequency emphasis than is usually noted from more distant whales. The higher frequencies are rapidly attenuated with distance.

his work at sea. Listening by means of his ship's echo sounder, underwater sounds from sperm whales were identified. At first the sounds were thought to be hammering somewhere in the ship, but as the whales approached, a variety of impulses were correlated with their presence (Figure 1). Later that year, Richard Backus, also of the Woods Hole Oceanographic Institution, recorded sounds from other sperm whales. And so it has gone. As we approach the midway point in 1977, we have several hundred hours of sperm whale sounds on tape.

Our first analyses of these sounds emphasized the impulsive quality of sperm whale sounds. We noticed the relative power of individual clicks (up to 75 or 80 decibels with regard to 1 dyne per square centimeter at 1 meter). We also noticed that they were broad-bandwidth pulses with energies above 20 kilohertz (kHz). Major emphases in frequency were often found in the 2 to 6 kHz range, with a wide variety of click repetition rates. Often the click series, like the hammering of carpenters, went on for several minutes and at quite slow (1 to 1/2 second) repetition rates. Sperm whale sounds and sounds from seventeen other whales and porpoises were issued on a record by Schevill and this author in 1962. The sperm whale sounds were the only ones that were entirely impulsive — that is, no squeals, moans, or whistles, only clicks produced at a variety of repetition rates. This is still true — we only hear clicks from sperm whales.

Backus and Schevill in 1966 reported on the characteristics of sperm whale clicks. They found that during a few minutes of recording the clicks of individual whales were often found in regular sequence, usually very much alike. It was suggested that the repeated characteristics of

sequential clicks might be the result of a "signature," or individual vocal quality (Figure 2). On occasion, these whales apparently shifted the repetition rate of their clicks to match the rate of echo-sounder pulses — perhaps, we thought, to avoid the interference of the echo sounder. We wondered if the main function of their clicking might be for echolocation.

We thus had learned much about sperm whale clicks, but relatively little yet about the whales. Off the Atlantic coast of the United States, sperm whales are often spotted in groups of from

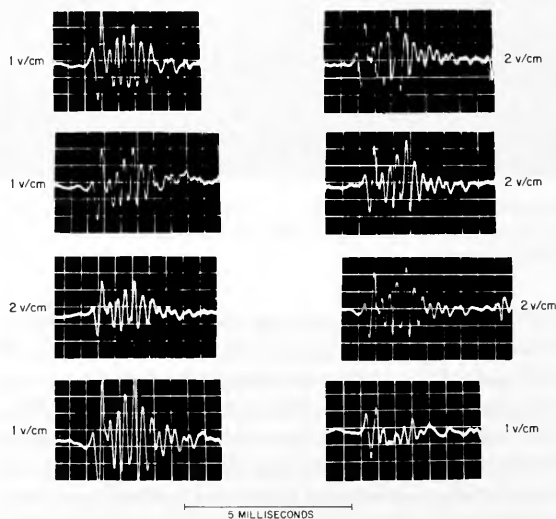

Figure 2. Sequential clicks from a sperm whale are very similar, but somewhat different from the clicks of other whales. It has been suggested that each whale might have a unique "signature" in their clicks. (Courtesy Richard Backus and William Schevill, in *Whales, Dolphins and Porpoises*, University of California Press)

Figure 3. Two sperm whales swimming in the North Pacific. Note the distinctive body shape and the position of the blowhole. (Courtesy S. Ohsumi, in Whales, Dolphins, and Porpoises of the Western North Atlantic, by S. Leatherwood, D. K. Caldwell, and H. E. Winn, NOAA Technical Report NMFS Circ-396)



two to twenty whales, most often located by their low, bushy blows (Figure 3). At the surface, sperm whales sometimes lie almost stationary, blowing irregularly — a few inches of back showing. Then, one after another, they dive, raising their flukes well out of water as they go — often just as we arrive (Figure 4). The whales may return a few minutes later, or that may be the last of them. It was obvious that our visual studies of these animals did not give us much information.

The Pinger Problem

We turned, therefore, to underwater acoustics. Echo sounders, we found, were of only limited use because the whales reacted to the pulses, which probably modified their behavior. We wanted to use the whales' own sounds. By triangulation and comparison of the sounds received on several hydrophones, we hoped to locate a whale by its underwater clicks. Theoretically, this system should have worked easily, but the mechanics of maintaining known hydrophone separations and keeping track of their relative positions proved difficult at sea. We tried using a floating, non-rigid arrangement, with acoustic measurement of the dimensions of the array of hydrophones. Pinger sounds were put into the water, and their arrival-times at the hydrophones gave relative hydrophone positions. Then, we computed the relative positions of the underwater sperm whale clicks. Tests with more accessible sound sources showed that the system worked — we tracked towed pingers, a Coast Guard cutter's echo-sounder pulses, and several local cetacean species. It was time to try it on sperm whales.

On a cruise in 1972, we found sperms about 320 kilometers off the coast of Delaware. Quickly, we put our hydrophones overboard and listened to multiple click series from several whales; one was very close. The whales had just gone down. As fast as possible, we turned our pingers on for a few pings so that we could be certain of the hydrophone positions. The pinger sounds recorded well on all channels — we would have good acoustic locations for our hydrophones. But the sperm whales had stopped clicking! Only distant whales could be heard. Two minutes dragged by while we listened intently. Suddenly, a not-too-distant whale began clicking and we quickly turned on the pinger switches — we had to know where our hydrophones were so that we could locate the whale that was now clicking. Again, our pings rang out underwater and were received clearly by all hydrophones. But again the whale was silent. After a wait of several minutes, the clicks resumed farther away, but very distinct. Again, we turned on the pingers, and again the whale stopped clicking. Why?

During that cruise, we encountered several groups of sperm whales, and on seven occasions whales passed close to our hydrophones. They would have provided ideal underwater acoustic tracks — except that all seven stopped clicking when the pingers were on!

Our efforts to study the whales underwater did not meet with much success. We went back to the lab and studied our tapes, computing short segments of sperm whale tracks. We reviewed our library of previous sperm whale recordings, and then went back to sea and tried again and again. We found that one or two underwater pinger pulses



Figure 4. Two sperm whales show their broadtail flukes as they begin dives off Baja California. (Courtesy K. C. Balcomb, in *Whales, Dolphins, and Porpoises of the Western North Atlantic*, by S. Leatherwood, D. K. Caldwell, and H. E. Winn, NOAA Technical Report NMFS Circ-396)

did not appear to bother the whales, while continuous pinging was largely ignored. Short series of six to ten pinger pulses, however, made the whales fall silent.

We eventually succeeded in tracking a few whales for awhile as they dove. Sometimes we stayed with the same group for several hours. Even when the whales were too far away for accurate computation of their underwater positions, we often could get a good direction to sound sources. Also, with a three-dimensional hydrophone array, we derived vertical direction that indicated a depth vector (Figure 5). Some of the whales' underwater behavior began to unfold.

To initiate a dive, the sperm whales usually raised flukes into the air and slipped beneath the surface with little disturbance, apparently starting downward at a steep angle. Only occasionally were clicks heard from whales at the surface. The clicks usually began when a diving whale reached a depth of about 5 meters. At this depth and for as long as we could follow them, the whales maintained diving angles of from 10 to 15 degrees. The initial steep angle was converted immediately below the surface to a shallower dive angle.

During each dive, the whales that had been at the surface together routinely separated and fanned out underwater. They often maintained separations of 100 meters or more in depth and in plan. When they returned to the surface for breathing, however, they often appeared at the surface within tens of meters of each other. In one analysis, a plot of acoustic bearings to a group of

nineteen sperm whales showed their underwater positions scattered over several cubic kilometers (Figure 6). We wondered if the whales' underwater distribution could be designed for effective foraging.

Since the sperm whales usually separated as they dove and often returned to the surface within close distance of each other, they obviously maintained contact with each other. Was it by

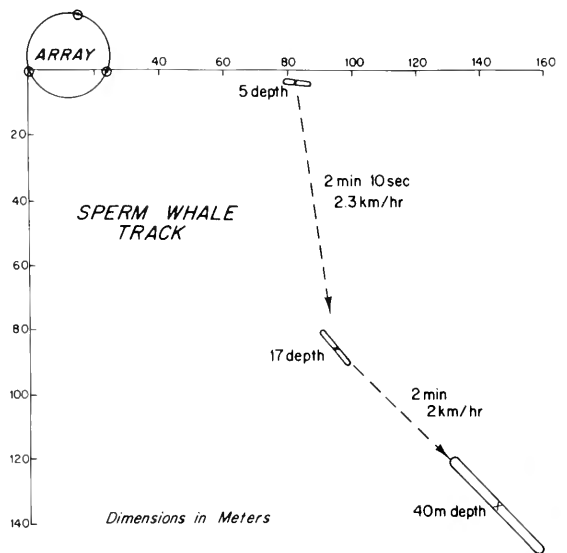
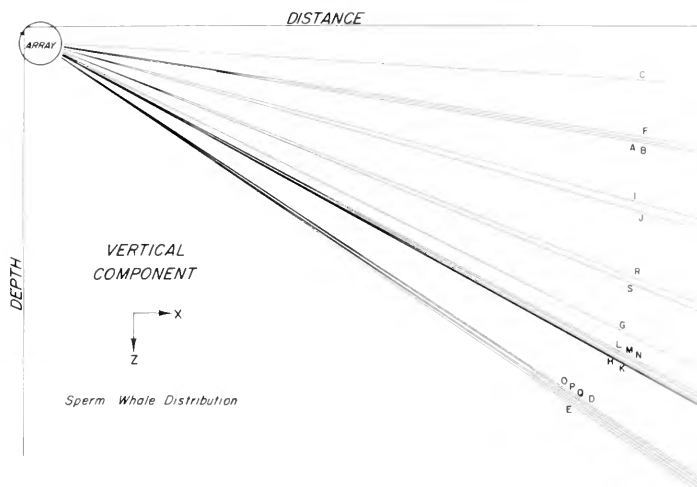

Figure 5. The track of a submerged sperm whale in horizontal projection is drawn from three groups of acoustic locations of the sounds of the whale as it moved downward and away from the hydrophone array. The array is drawn in the surface plane so the deep hydrophone is not shown. The depth is more accurate than distance in these plots. (Courtesy Deep-Sea Research)

Figure 6. Vertical lines of relative direction are shown for 19 sperm whales. Each whale is lettered, with the vertical bearing spread over 30 degrees. The figure illustrates how the whales fan out after diving at the surface. The bearings were derived from positions calculated from sound arrival-time-differences on a three-dimensional hydrophone array. The whales are about a kilometer distant from the arrays. (Courtesy Deep-Sea Research)



sound? Their clicks are loud enough to be heard over several kilometers. Perhaps, we theorized, they could recognize each other by the quality or spectrum of their clicks, and so come back to the surface together. We wondered if a whale could sort out the effects of distance and reflection enough for continued recognition of another's clicks.

On the other hand, these whales sometimes disappeared completely after a dive. They were air-breathers and had to surface, but not necessarily near us again. Could their next surfacing be beyond the horizon? A practical horizon for sighting blows under good conditions is about 3 kilometers (a little less than 2 miles). How long would a whale have to stay down to go that far underwater? We reviewed our experience with these animals and remembered 15 to 20 minutes or more between blows, but we were not sure that these were always the same whales we had seen before.

Careful analysis of our tapes allowed us to follow the sounds of whales that had recently submerged. We found sometimes that though these sounds were still audible from whales that were well below the surface, other whales could be seen blowing nearby. The blows were not from the whales we were listening to! We began to realize that we really did not know how long sperm whales could stay down. The whales that we were listening to were still down and moving off. We began to think (without proof) that these whales might be able to stay down for an hour — the old whalers thought so, too.

Behavioral Characteristics Emerge

Use of the hydrophone array made us aware of a variety of behaviors that we had been unable to

observe before; we now could separate out and follow the sounds of *individual* whales by the direction of sound arrival, if not by the actual acoustic location of the whale underwater.

In following the sounds of individual whales over several hours, we found that their click sequences were highly variable; they sometimes went for minutes without clicking at all. In a group of whales, sometimes only one would produce clicks, sometimes all, and sometimes they took turns. The whales obviously controlled the intensity level of their clicks, which began to look less like echolocation signals and more like a means to keep in contact with other whales.

Because we had studied many other cetacean species that also produced clicks that were demonstrably used in echolocation, we had assumed that sperm whale clicks were for echolocation, too. This, we had thought, would be an especially useful ability for deep divers, where light is reduced. Instead, evidence now pointed to communication.

Over short time periods, successive clicks from the same whale were very much alike, mostly varying in ways that could be explained by environmental factors, such as absorption with distance and reflections. We could not find click variations sufficient to carry information. But what about the repetition rate? The whales used a wide range of click rates, from less than 1 per second to more than 75 per second.

These whales have an excellent perception of timing, at least on a short-term basis. Backus and Schevill in 1966 demonstrated that sperm whales are able to maintain regular click spacing that far surpasses the abilities of humans in similar tasks, such as drummers, or telegraph operators. The whales also are able to change their click rate to

Coda Patterns	Duration (seconds)	No. of times heard
/ / / / /	.98 - 1.02	66
// ////	.78 - .84	21
// / / /	.82 - .90	20
/ / / / /	1.03 - 1.05	3
/////	.77 - .85	34
/ / / / /	.90 - .98	25

Figure 7. The variety of click patterns in sperm whale codas is schematically represented, each mark representing a click. The codas are listed with the range of durations measured for each pattern and the number of repetitions of each coda that were identified in one 15-minute recording. (Courtesy Journal of the Acoustical Society of America)

match that of an echo sounder. Our recordings have many examples of click series that include a wide variety of click sequences, some of which are repeated again and again. We turned our attention toward the sequence of click patterns.

One type of click sequence is particularly noticeable but only occurs occasionally. This is a short series of three to forty or more clicks produced in stereotyped repetitive sequences that we call "codas." The pattern of the clicks in a coda can be repeated almost exactly two to sixty or more times at intervals of a few seconds or minutes. Successive codas from one whale had the same general click characteristics and the same click repetition pattern. Click patterns in codas from different whales are sometimes very complicated (some very close to a "shave-and-a-haircut — two-bits" pattern) and rhythmic, but often they are simply different numbers of clicks produced at relatively regular rates. Each whale seems to use a coda that is different from the codas of all other whales in the neighborhood. The pattern of clicks appears to be unique to individual sperm whales over at least the periods of observation, a maximum, so far, of four hours.

When codas are audible, the click patterns identify individual sperm whales for us (throughout the period that we are able to maintain contact).

Presumably, codas also serve as unique individual identifiers to other sperm whales. Codas from different whales (with differences in level, frequency emphasis, direction) always are formed of different temporal patterns, so that they are immediately separable to our ears. This suggests purposefully chosen identifications sufficiently varied from those of all other whales in the area (Figure 7).

In reviewing these experiences, it is possible to fit the codas into patterns of behavior:

- 1) Codas are only heard from submerged sperm whales; whales at the surface are often silent.
- 2) Codas are heard when whales meet underwater; when two separate groups come together, and when individuals approach each other.
- 3) Codas are sometimes heard as exchanges between whales, apparently reacting acoustically to each other.
- 4) Coda exchanges occur only between animals that are close together; those that are distant from each other do not appear to exchange codas.
- 5) Codas sometimes seem to elicit silence in other more distant sperm whales, perhaps indicating attention.

Is it possible that the pulses from our pingers used in the array experiments sounded like a coda to the whales? They reacted with silence, just as they did to the introduction of a distant sperm whale coda in the ambient sound. The whales seemed to quiet so that they could listen. Is it possible, then, that temporal coding of click patterns can be heard better at a distance than subtle frequency differences in the clicks of individuals? Very likely. A click probably can be modified by reverberation, reflections, and frequency selective absorption to the point of nonrecognition. Coda patterns are generally distinct units of sound to the human ear, and are identifiable through heavily competing backgrounds of clicking sperm whales. This would probably be true for the sperm whale ear as well.

Often when one sperm whale coda is heard, codas from a second or third whale are also heard within a few minutes, but usually not in an obvious pattern of reaction to each other. Occasionally, however, we hear interspersed sequences in which there has been an apparent exchange of codas, always from animals that are not far apart. Can this be a purposeful exchange of codas?

SPERM WHALE CODA EXCHANGES

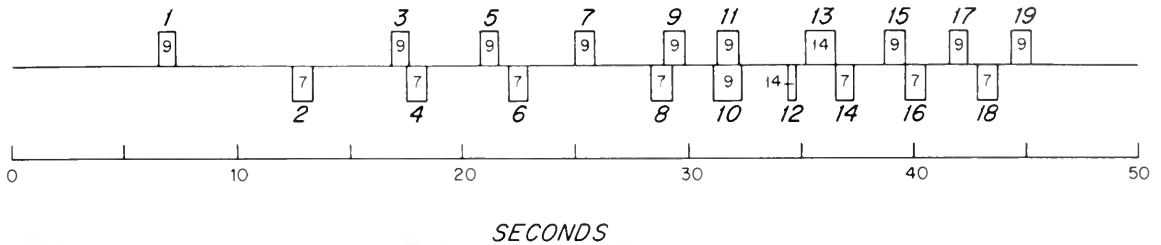

Figure 8. An exchange of codas from two sperm whales. The nine-click codas from the first whale are shown as the odd-numbered codas above the line, and the even-numbered seven-click codas are from the second whale and are shown below the line. The small numbers within the boxes indicate the number of clicks in each coda, and the larger italicized numbers denote the sequence of codas. Note the change that occurs at codas 10, 11, 12, and 13. (Courtesy Journal of the Acoustical Society of America)

Coda Exchange Analyzed

A recording that includes a possible exchange of nineteen interspersed nine-click and seven-click codas has been analyzed in detail. The two whales are a kilometer or more distant and out of sight underwater, at a depth of about 200 meters. An array of four hydrophones was used so that we would be able to plot the movement of the whales and perhaps find evidence that could corroborate our aural impression of an interaction by the whales (Figure 8).

Acoustic source locations were computed for as many as possible of the clicks in all nineteen codas. These were then plotted coda-by-coda. The results show that changes in the acoustic exchange coincide with a shift in the whales' underwater movements. The whale with the nine-click coda was stationary for the first portion of the exchange, while the whale with the seven-click coda moved southeast toward the first whale. They exchanged codas as the second whale approached. On meeting, there was a variation in the coda signals that included simultaneous codas, changes in click pattern, and temporarily lengthened sequences. Then, the coda exchange was resumed, and the two whales swam off together, now moving southwest. Subsequently, four more nine-click codas were heard and their analyses showed that the nine-click whale continued the same relative progression and direction of movement. We are convinced that the whales reacted to each other, both acoustically and physically.

What information was exchanged? If the coda is an individual identifier, the whales were repeating "I'm Moby," "I'm Moby;" "I'm Dick," "I'm Dick." This may not seem like a particularly scintillating conversation, but it could have been of real value to the whales.

Imagine cruising your 45-ton body through those dark waters at a speed of 3 knots or more. There would be a good deal that you would want to know about someone else moving in the same water. Who are you (therefore, how big, how strong, how friendly)? Where are you (how close, how deep, which direction)? Are you moving (how fast, on a collision course)? The "who" might well be the most important question, so a unique identifier would be needed. Answers to the other inquiries could well be derived from the same identification signal. Doubtless you as the whale have had experience in assessing direction by listening to signals, distance by judging relative attenuation of parts of the signals, and speed by sequential location of components of these sounds.

The temporal coding of sperm whale click sequences, which is characteristic of the stereotyped coda patterns, may also be noted in other sound sequences. Sometimes the time intervals separating codas are of such regularity that the codas and intervening intervals appear to be a part of a longer, stereotyped sequence. In addition, temporal coding is evident at times in much longer click series from these whales. Series with regular click repetition rates may begin to skip clicks, or change to clicking in pairs or triplets. It may be that all sperm whale sounds have a communicative function, such as maintaining contact with others in a widespread herd.

Often only one sperm whale in a group produces sound. That whale may click regularly for 3 or 4 minutes and suddenly stop, and another whale may then click for a few minutes. Overlapping of click series is common, but continuous clicking by one whale for long periods is not. Individual whales may be silent for most of a dive period. Changes in

the click repetition rate occur during most click sequences, but the whales seem to prefer relatively slow, regular rates. When only a few whales are present, these rates often appear to be different for different whales. One or two whales of a group sometimes appear to be acoustically dominant.

Though our results appear to be consistent, we do not know if the whales always act as they did during the experiments. The next sperm whales we meet could force a re-evaluation of these interpretations: our data base is just too small for certainty. Because of attention to their sounds, however, we already know much more about the behavior of these whales underwater than we do of any other whale. While we have just begun to fit the bits of acoustical evidence together, it is obvious that sound plays an important role in the behavior of sperm whales.

William A. Watkins is a Research Specialist at the Woods Hole Oceanographic Institution.

Acknowledgement

This work is supported by the Oceanic Biology Program of the Office of Naval Research, N00014-74-C0262 NR 083-004.

References

- Backus, R.H., and W.E. Schevill. 1966. *Physeter* clicks. In *Whales, dolphins, and porpoises*, ed. by K.S. Norris, pp. 510-27. Berkeley, Ca.: Univ. of California Press.
- Shevill, W.E., and B. Lawrence. 1949. Underwater listening to the white porpoise (*Delphinapterus leucas*). *Science* 109: 143-44.
- . 1953. Auditory response of a bottlenosed porpoise, *Tursiops truncatus*, to frequencies above 100 KC. *J. Exp. Zool.* 124: 147-65.
- . 1956. Food-finding by a captive porpoise (*Tursiops truncatus*). *Breviora* 53: 1-15.
- Shevill, W.E., and W.A. Watkins. 1962. Whale and porpoise voices. A phonograph record. Woods Hole Oceanographic Institution, Woods Hole, Mass, 24 pp. and phonograph disk.
- Watkins, W.A., and W.E. Schevill. 1972. Sound source location by arrival-times on a non-rigid three-dimensional hydrophone array. *Deep-Sea Res.* 19: 691-706.
- . 1974. Listening to Hawaiian spinner porpoises, *Stenella cf. longirostris*, with a three-dimensional hydrophone array. *J. Mammal.* 55: 319-28.
- . 1975. Sperm whales (*Physeter catodon*) react to pingers. *Deep-Sea Res.* 22: 123-29.
- . in press. Spatial distribution of *Physeter catodon* (sperm whales) underwater. *Deep-Sea Res.*
- . in press. Sperm whale codas. *J. Acoust. Soc. Am.*
- Worthington, L.V., and W.E. Schevill. 1957. Underwater sounds heard from sperm whales. *Nature* 180: 291.

ACOUSTICS IN MARINE FISHERIES

--AN UNDERUSED TOOL

by Paul T. McElroy

The successful use of acoustics in marine fisheries and related research areas in the past has most often occurred when it has been closely related to a behavioral and physiological understanding of fish. This understanding is critical to the design and interpretation of new acoustic experiments, which must precede the development of improved instrumentation for the world's fishing fleets. Interestingly, this philosophy is central to the approach of the Soviet Union, which is trying to improve fishing by employing many new technologies.

Acoustics in a fisheries context can be separated into three categories: 1) the problems of catching fish; 2) the evaluation of fish as a resource so that they will not be expended, but allowed to renew themselves; and 3) techniques that might improve capabilities in the first two categories, while providing the basis for entirely new technologies, such as the "farming" of fish rather than the present method of "hunting."

In turn, the fullest application of acoustics to the fisheries requires the unified use of three techniques: 1) deterministic mathematical models of individual fish based on their physiology; 2) statistical descriptions of the usually random distribution of fish in the water column, based on their behavior, and the subsequent statistical descriptors of the scattered sound waves from groups of such fish; and 3) the willingness to use more complicated instrumentation as our knowledge of the deterministic and statistical processes becomes more precise.

Acoustic techniques are widely used by many of the world's fishing fleets and sport fishermen. Internationally, investigators have been applying acoustic methods to the study of fishing since the 1930s. In relationship to the global need for husbanding this resource, however, this writer finds the effort inadequate. While there are

exceptions, most recent research on an international level has been confined to a single concept — the energy method. Its limited success has unduly influenced decisions to apply a wider range of technological tools. Neither the biologist nor the physical scientist alone can solve these problems; they must join as full partners in future investigations if progress is to take place.

Acoustic Characteristics of Fish

Each fish is a scatterer of the sound incident on it. It is not like a mirror returning the sound in just one direction. Rather, sound incident from one direction is reradiated in all directions. Backscattering refers to the portion of this reradiated energy that returns to the sound source, such as a fishing vessel, which uses the same transducer as both source and receiver.

The actual energy returned from a fish as seen by a measurement system is dependent on both the orientation of the fish relative to the direction of the sound pulse (so-called "aspect angle"), and its orientation relative to the direction of the scattered energy. Actual measurements on fish show that the variation of scattered energy with angle can be very great; directivity patterns that pictorially show this angular variation display many peaks and valleys. These patterns change as frequency is changed, becoming more complex at higher frequencies. There also are significant variations in the magnitude of the scattered energy, due to both the measurement frequency employed and the size and physiological characteristics of the fish.

Fish scatter sound because they contrast with the surrounding water. Three parts of the typical fish show differing degrees of contrast (in terms of their material densities and relative ease of compression). They are fish tissue, bony structure, and gas found in bladders. If there is no contrast in

these quantities, no sound is scattered — a situation that would occur if the fish looked exactly like seawater. This is not entirely hypothetical; for example, a jellyfish weighing 120 kilograms captured in a mid-water trawl was an insignificant target despite its size because its density was only about 1 percent greater than that of water.

The bony structure of the fish, including the spine, vertebra, and skull, provides a target of high contrast. Fish tissue provides much less contrast, but enough so that it can contribute to the scattered energy. In addition, motions of fish tissue in response to the pressure of the acoustic waves dissipate some of that energy, which in turn has an effect on the variation of scattered energy with frequency.

Finally, the gas bladder, which is not found in all fish, provides the most striking contrast with the water, particularly because it is so much more compressible. The incident sound energy interacts with this gas bubble, which changes its volume in an oscillatory manner at the frequency of the sound. This bubble then reradiates. There is one frequency at which the “springy” bubble pushing against the surrounding water mass becomes a resonant system. This means that the fish at this frequency becomes a much more significant target (Figure 1). Its effective area in intercepting sound (called scattering cross section) becomes markedly greater, in fact, exceeding the actual area of the bladder by many times.

The resonant frequency of fish that are of interest to commercial fishermen lies in the range of 500 to 2,000 Hertz (Hz), but their fish-finding

apparatus operates at higher frequencies. Thus, this feature of fish as resonant targets is unutilized.

The spring-like character and size of the bladder changes with the depth at which a fish is swimming. It becomes stiffer and sometimes smaller with increasing depth, which results in an increase in the resonant frequency. Thus, there is no unique resonant frequency for a given fish. But the way the resonant frequency changes with depth can provide information on the physiological characteristics of the fish — namely, the way in which it changes the actual number of molecules of gas in its bladder.*

The scattering characteristics of a fish, then, are determined not only by its external shape, but also by its internal characteristics, such as the relative amounts of flesh and bone, and the occurrence or absence of a gas bladder. Its size determines the magnitude of scattered sound. Its effectiveness as a target is parameterized in a quantity called target strength, a term also used when detecting submarines.** But, as we have seen, target strength is extremely variable, depending on the orientation of the fish relative to the sound source and receiver, and the frequency used for detection.

The shifts in sound frequency due to the motion of a target are known as Doppler effects.† The motions of fish are determined by their particular behavior pattern, be it search for food, feeding, mating, or eluding predators. This pattern determines average speed, the frequency and amplitude of the tail motions, variations in speed, and the path followed.

A test of the relationship between Doppler shift†† and behavior was conducted in 1972 by D. Van Holliday of Tracor, Inc. A Doppler pattern of alternate bursts of speed and gliding was observed, consistent with the feeding characteristics of jack mackerel and northern anchovy (Figure 2). Interesting correlations of fish speed and the rate of tail motions were found, consistent with the known characteristics of large fish.

*Scientists in the Soviet Union are studying gas bladder physiology under conditions of weightlessness — guppies have been taken into space.

**Target strength is 10 times the logarithm of the scattering cross section $\div 4\pi$.

†The Doppler effect is a phenomenon whereby a change occurs in the observed frequency of a wave due to motion of either source or target relative to the water.

††The Doppler shift is the change in the observed frequency of a wave, due to the Doppler effect.

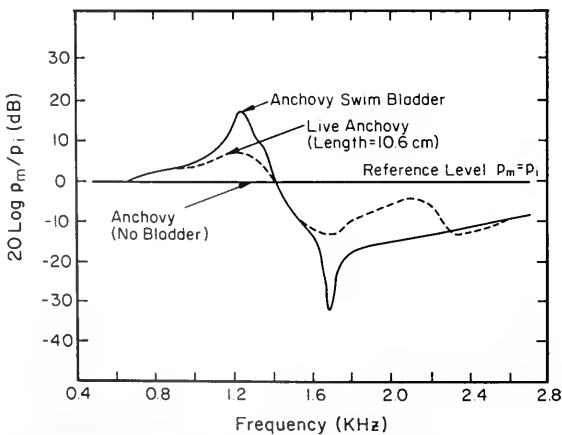

Figure 1. Frequency response of the acoustic scattering from a live anchovy and from its bladder. (Adapted from Batzler and Pickwell, Resonant acoustic scattering from gas-bladder fishes, Proceedings of an International Symposium on Biological Sound Scattering in the Ocean, 1970)

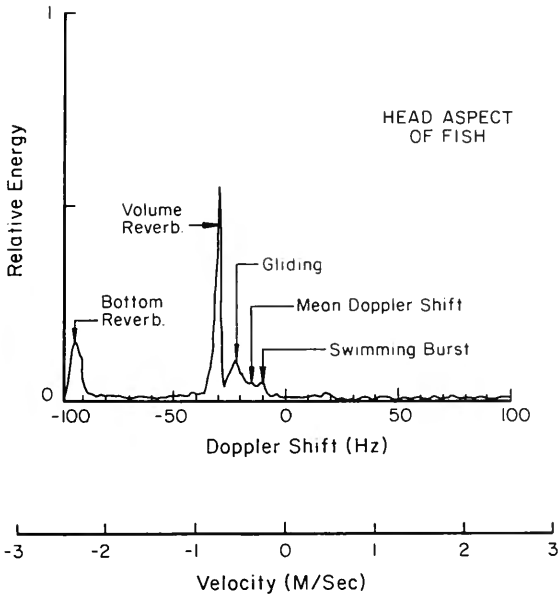

Figure 2. Doppler shift and spreading due to fish school feeding patterns. The reference level for zero velocity in the water column is the volume reverberation peak. (Adapted from Holliday/The Journal of the Acoustical Society of America, 1974.)

Group Characteristics

The characteristics of individual fish are deterministic. That is, the acoustic features of the fish as targets can be directly inferred from mathematical models based on their physiology and behavior. However, almost all measurements on fish at sea are made on groups. The characteristics of these groups are given in terms of statistical rather than deterministic models. In the simplest view, the fish are distributed randomly in the water column, and so a composite signal scattered from many such fish is made up of components (one for each target). These are added together in a random fashion.

How do fish usually group? Figure 3 is taken from C. M. Breder and summarizes his findings on the four most common types of fish groupings — solitary, aggregation, school, and pod. He noted that these are really nodes on a continuum, with other groups relatively rare. Within the four groups, there are great variations in packing density (ranging from many body lengths to close packing), relative orientation (ordered or disordered), directed motion of the group (or lack of it), random or highly ordered placement of individuals relative to each other, and the occurrence or absence of a well-defined boundary to the group. For example, rainbow trout have been observed grouped in a regular array.

Most measurements are made on groups. Individual targets are comparatively weak. Generally, the commercial fisherman is concerned only with groups (an exception would be long-line fishing for tuna) as is the agency studying the stock. Measurements on individual fish include both laboratory work on dead or drugged fish and studies in more natural surroundings, such as the attempt in 1975 by the National Marine Fisheries Service (NMFS) at Jeffries Ledge off Cape Ann, Massachusetts, to determine the target strength of single drugged fish when confined in the sea. This program became quite complex, involving moored systems, and a West German habitat for *in situ* study of herring larvae.

The acoustic consequences of fish grouping can be separated into three classes — low, medium, and high fish density (numbers per unit volume). At low densities, the echoes from individual fish are small enough in number that they do not overlap; each can be counted, giving an estimate of the fish density. At intermediate densities, echoes from different fish overlap, so that they can no longer be counted individually. A way must then be found to

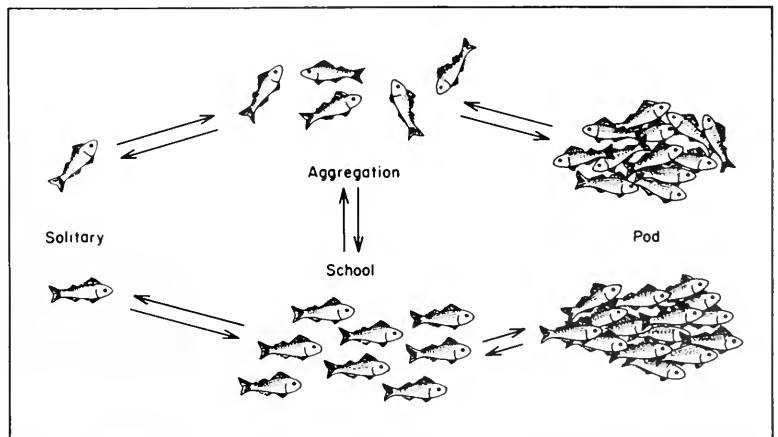
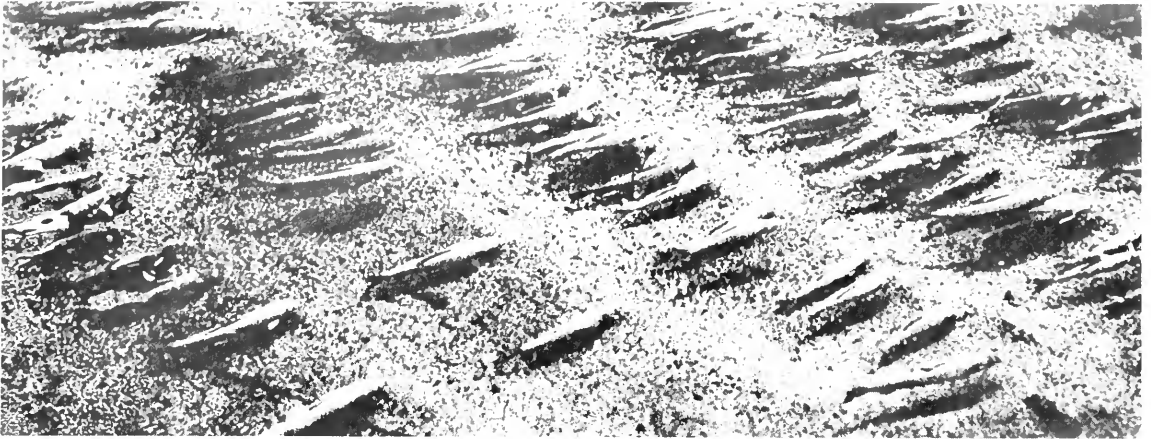

Figure 3. The four common types of fish grouping. (Courtesy C. M. Breder/American Museum of Natural History)



*An array of rainbow trout (*Salmo gairdneri*) over a riffled bottom in a river; this deviates from the more usual irregular spacing of fish in most schools. These fish are found in Atlantic, Pacific, and fresh waters. (From C. M. Breder, *Bulletin of the American Museum of Natural History*. Reprinted courtesy Field & Stream)*

estimate the number of fish. The most common technique is the energy method. The energy within a certain time interval, which is then related, somewhat inaccurately, to a particular depth interval, is measured. An estimate is then made of the average target strength (and possibly its variation) of fish in the group — that is, what energy an average fish returns. The result of dividing the energy in the time interval by this average energy gives an estimate of the number of fish (the variation sets bounds on the accuracy of the estimate of fish density).

The problem lies in determining the average individual target strength. Some of the great variability of target strength with angle is eliminated by the statistical averaging over many fish with different orientations. If many species are grouped together, there is no meaningful average. Fortunately, commercial species are sometimes found in groups of their own kind. If the members of this group are nearly the same size, an average is meaningful.

In 1976, John Ehrenberg of the University of Washington implemented a dual-beam transducer system that determines the distribution of target strengths — the combined narrow and broad-beam transducers permit the elimination of uncertainties in the determination of the target strength of individual fish. These ambiguities occur because fish are randomly distributed within the beam pattern.

Other issues exist in the energy method, such as determining just what is the effective volume of water that is returning sound from fish of varying target strength, especially at different depths. Despite various efforts, it is clear that the

acoustician has not yet convinced the fisheries biologist that he is determining density with much precision — errors by a factor of two or greater are likely.

At high densities of fish, the acoustic energy may undergo multiple scattering — that is, be returned from more than one fish before it is detected at a receiver. This effect has been observed at sea, where echoes from schools persist for longer periods of time than actually possible (the echoes of a school can start above the bottom and continue for periods of time long after bottom echoes are first received). Paul Smith of the NMFS, in his investigations using side-scan sonar, thinks anchovy concentrations might lie in the range of 1,300 to 3,700 per cubic meter.

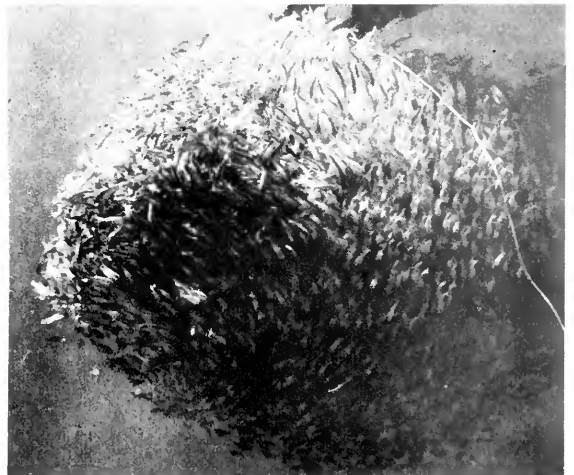

*An unusually dense pod of scorpion fish (*Sebastodes paucispinis*) observed under the stern of a boat. (From C. M. Breder, *Bulletin of the American Museum of Natural History*. Photograph by Logan O. Smith)*

Catching Fish

Acoustic methods for fish finding have become increasingly sophisticated over the years, but their application has been uneven. Factors affecting this are the size of fishing vessels, and the government support for acoustic research in fishing within individual countries. The record of the United States is the least notable of the major industrial powers.

Several sectors of the American fishing industry are an impoverished, labor-intensive operation. Were improved tools developed, many fishermen might not be able to afford them. By the same token, the techniques that are appropriate for the huge factoryships from Eastern Europe and the large West German herring boats are largely not useful for the smaller American vessels. While American industry does offer a variety of acoustical equipment, it is not noted for commercial leadership in the field in the way that, say, Simrad, a large industrial concern in Norway, is. The U.S. National Marine Fisheries Service generally has felt uneasy about using acoustics in resource evaluation, and has been unwilling, until recently, to commit any significant funds (in relation to the need) to development of acoustic tools.

The U.S. Navy, on the other hand, has supported acoustic studies of mid-water fish. Although these fish are of neither a size nor density to be of interest commercially, the research has provided a basis for the deterministic modeling of fish and the understanding of their relation to the ocean environment. The Woods Hole Oceanographic Institution's submersible *Alvin*, built and supported with Office of Naval Research funds, was used in a combined acoustic and biological observation of dense schools of mid-water fish.

The Soviet Union and the Eastern European countries with their large factoryships provide an interesting contrast. Acoustic tools are widely used both for assessment and fish finding. Among some of the more recent developments: 1) a standard text has been written for sonar operators in the fisheries; 2) the Soviet Union, with more than 2,000 fishing vessels throughout the world, has studied acoustic interference between vessels using fish-finders; 3) East Germany is presently installing on supertrawlers fish-finders purchased from the Soviet Union, which are useful to depths of 3,000 meters; 4) joint acoustic assessment efforts, such as an evaluation of White Sea resources by the Soviet Union and East Germany, are currently being undertaken. Soviet instrumentation, however, has tended to reflect Western trends. An exception is their *TINRO-2* submersible, which was designed for

studies of fish behavior and employs both sonic navigation and sonar gear.

What is the range of acoustic techniques employed by fishermen? Some of the simplest devices are pictorial. As a vessel steams across the ocean, its transducer looks downward and sends out a short burst of acoustic energy. Every fish hit by that pulse scatters sound back to the detector. The returned signal becomes weaker with increasing depth and deviation from the vertical direction, according to the transducer's beamwidth (Figure 4).

These returned signals are amplified, and then darken a piece of recording paper. One dimension of that paper is depth, the other corresponds to the horizontal path along which the vessel is steaming. The recording paper slowly comes out of a machine as the vessel advances. The result is a picture that is dark where targets occur. The shape of the trace on the paper depends on vessel speed (in relationship to the paper speed), size of the target (individual fish or whole school), whether the vessel passes directly over the target or off to the side, and the length of the sound pulse (if long, individual targets overlap; if short, individual targets within a larger school may be distinguished).

Refinements of pictorial techniques include a display of only a limited portion of the water depth, such as the region near the bottom, and a referencing of the display to the ocean bottom rather than the surface, so that groups of fish a fixed distance above the bottom appear in a horizontal line on the paper even when the depth changes.

Skilled fishermen learn to interpret these traces. The location of the trace, whether in mid-water or on the bottom, is a guide to the species, if a fisherman knows his area well. However, all these clues are useful in species identification only when the area has been well sampled in the past; a skilled fisherman in an unfamiliar area is unlikely to have much success in identification.

Researchers have used such pictorial displays to locate the boundaries of an area within which particular species may be found. Migration patterns of Norwegian herring have been traced in this way, and cod have been found to lie within a narrow range of isotherms south of Spitsbergen during early summer. This behavioral information is then given to the fisherman, permitting him to go to the area at the proper season. Once there, he uses his own pictorial display to determine where to set his nets.

Another technique is the white-line method, which was designed specifically for bottom

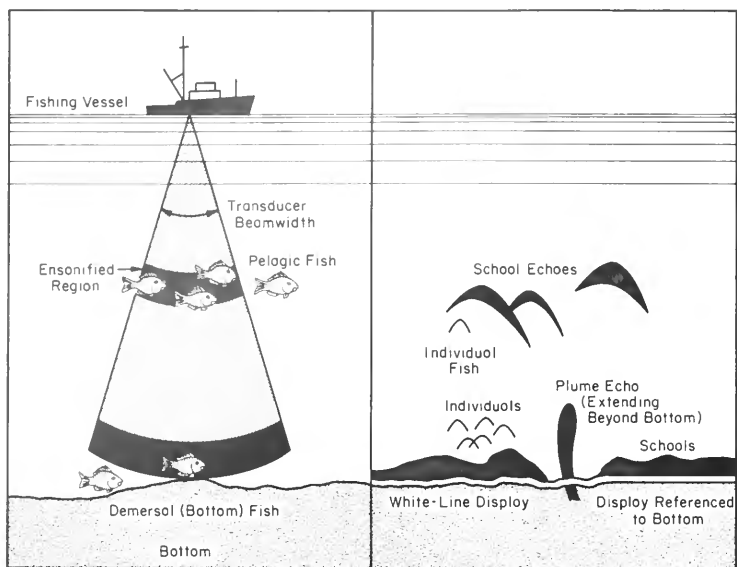

Figure 4. At left, ensonification of fish schools and individual fish by downward-looking echo sounder. (Fish at lower left cannot be separated from bottom echo.) At right, typical pictorial displays of echoes from fish found in the mid-water and near the bottom.

fishing. The echoes from fish near the bottom tend to merge with the bottom itself in the usual pictorial display and cannot be distinguished. Since the bottom echo is far stronger than the fish echoes, its arrival can be used to trigger a blanking of the voltages used to darken the paper. This blanking is allowed to persist for only a short period of time, and then the voltage corresponding to the bottom echo resumes. The result is a white line on the chart paper, separating the fish and bottom echoes.

Side-scan sonar is a device covering a much larger area than the typical downward-looking transducer. It displays a swath on each side of the vessel (see pages 18 and 43). The British Gloria system has been used to display schools of herring clustered on the downstream side of shallow rocks during tidal current flow. Side-scan sonar provides a good tool for behavioral studies of fish, and has already been used extensively in studies on anchovy.

The West Germans have pioneered in the simultaneous use of a number of small transducers mounted on their huge herring nets. They are used predominantly to monitor the condition of the net opening and its head rope, incidentally giving some information on the number of fish entering the net. In an extension of this idea, the British have used an array of detectors (called a sector-scan) on a net to study trawl configuration and the entry of fish into the trawl. Since various effective ranges are possible, this concept would allow a more aggressive pursuit of fish by a trawler.

The question of whether improved tools should be made available to fishermen in light of an

already overfished resource has been answered emphatically by the Russians in a recent book entitled *Design and Use of Industrial Fishing Gear*. In this book, it is apparent that they are aggressively pursuing many technologies, including sound, that would both increase fishing efficiency and the number of fruitful fishing areas. Clearly, such an improved method must be coupled with effective resource management.

Evaluating the Resource

The world's need for protein has recently exerted a tremendous pressure on the fish resources of the ocean. This pressure will increase as more nations become aware of the medical hazards of protein deficiency. The diminished fish stocks off the Eastern coast of the United States provided a major impetus to the setting of the 200-mile fishing limit.

The National Marine Fisheries Service has for some time had the responsibility of monitoring these fish resources and developing recommended fishing limits on a year-to-year basis. Until recently these were only recommendations, which were then considered by the International Commission for the Northwest Atlantic Fisheries (ICNAF). American fishing limits are now set by the Secretary of Commerce, based in part on the recommendations of the NMFS.

A challenging technical question is how to set these limits in a rational way. There is a large biological data base extending into the past. But

extrapolation into the future is complicated by fluctuations in the fish resource. These fluctuations could be caused by such factors as major changes in climate, which cannot be inferred from past history. Also, the continued depletion of the resource by fishing affects the creation of new fish (called recruitment), complicating prediction.

Our need to rely completely on past data requires a continuous detailed updating of that data base. The methods now used are time consuming. They combine data on commercial landings of fish with surveys made by government vessels of fish and egg populations. Fisheries biologists recognize the need for supplementing their statistical data. Acoustics provides a possible means of surveying large areas.

A major part of the problem in accepting acoustic information is that of determining the degree of correlation between an acoustic and a biological measurement. This question is further complicated by the fact that so-called "ground truth" is unknown; biological sampling indicates *relative* changes in fish population from year to year. But except in the case of very sluggish fish, such as hake, the biologist is not sure what fraction of the fish subject to his net he is sampling. This, plus the fact that acoustic systems sample different water volumes from the net, almost always prevents absolute abundance measurements. Even so, relative estimates, compiled annually and compared to landings of fish, provide a way of evaluating the impact of changes on the ability to find fish.

The limited success of the energy method should not cloud one's overall assessment of the utility of acoustics. Different technologies suggest a much more hopeful outlook.

Future Trends

The immediate motivation for developing new acoustic methods is to improve our assessment capability and, to a lesser extent, to improve the fisherman's ability to locate fish. In the long run, one must ask if it is possible to control and husband the fishing resource to improve yields, and whether acoustic tools could help in that process.

A significant problem is still the identification of species. A number of new acoustic methods can be employed. The problem, however, is so complex that it is unlikely that any single method will solve this problem. We have seen earlier (Figure 1) the effect that a gas bladder has on the sound scattered from a fish. Measurements of scattering cross section versus frequency may provide a means of distinguishing groups of species because of gas

bladder variations. Such measurements would need to be made at a high speed to capture the fish before they change depth. The parametric array, developed in England, which does not change its ensonified volume as frequency is changed, might be useful in this task.

Doppler shifts caused by moving fish are related to their behavior patterns and hence are specific to certain groups of species. In addition, the grouping of fish is determined by both its species, and its particular behavior pattern at the time. Many fish group in schools with well-defined boundaries. Robert Swarts, while working at Honeywell, has shown that the autocorrelation function* of the signal returned from a school with a boundary is different from the autocorrelation if the boundaries do not exist. He has observed this autocorrelation-function effect in experiments. This type of measurement helps to reduce the number of possible species in a given observation.

Assessment requires not only an unambiguous determination of the species being sampled, but an accurate determination of the number of fish. A measure of absolute abundance is needed. No method provides that information as yet. An alternative determination of relative abundance, however, can be made by counting the number of times a signal, composed of scattering from many fish, crosses the zero voltage level. Other "signal distortion" mechanisms are also worth exploring.

I have mentioned the importance of relating acoustic measurements to a full understanding of fish in their natural environment. This relationship is complicated and subtle, requiring the processing of huge amounts of data. Pattern recognition is a discipline suited to this task. It seeks the underlying trends in complex measurements. I have had some success with these methods in studying spectra of sound scattered from fish at many different stations in the North Atlantic. One example is found in Figure 5; in another instance no geographic information was included in the analysis, yet all the stations in the Gulf Stream were clustered close together. When the cluster was looked at in detail, it separated into a display very similar to a plot of the actual geographic positions of the stations. Some chemical, physical/oceanographic, or food chain factor was affecting fish distributions, and hence the

*An autocorrelation function is created by multiplying a signal that is extending in time by itself. This multiplication is carried out for a series of time shifts between the signal and its replica. For each time shift, this multiplication is integrated to get a single number. A plot is then made of the integral versus time shift.

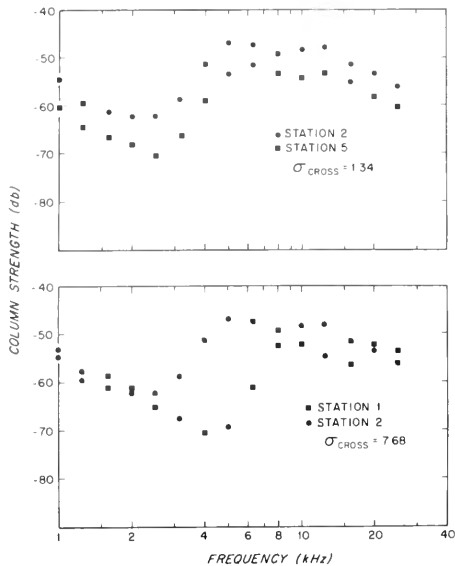

Figure 5. Top, comparison of two stations that have similar spectra and a low value of a similarity parameter. They lie in the same geographic region of the northwest Atlantic. Bottom, the comparison of two stations that have dissimilar spectra and a high value of the parameter. Hence, they are inferred to lie in different oceanographic regions, although quite close geographically. Station 1 is in Labrador coastal water, while 2 and 5 are in the Gulf Stream. (Courtesy The Journal of the Acoustical Society of America).

spectra, in a way that approximated variations in the latitude and longitude.

As transponders and telemetering devices get smaller and lighter, it will become more feasible to study the behavior and physiology of small commercial species by implanting sound sources. Investigators have implanted telemetering devices in larger fish, such as the tuna, and followed not only their motion, but variations in heartbeat or body temperature as the animal changes its depth. Studies of smaller species, tagged with light sound devices, are now being undertaken; plaice have been tracked in the open ocean and sockeye salmon tagged, giving their travel times through confined areas.

As a result of the lead taken by the Soviet Union, we are on the brink of some major changes in our husbanding of fish. Control of the resource is improving through 1) detailed acoustic studies of schooling as an adaptive behavioristic mechanism, and 2) the number of significant technological changes that are being made. For some time, the Soviets have harvested krill by attracting them with light and then using large pumps to suck them aboard. The effects of utilizing electric fields to harvest fish also have been studied. More recently,

sound and trace chemicals have been added to the suite of stimuli studied to enhance control.

In this country, William Tavalga, working at the American Museum of Natural History in New York, has recently studied the ability of fish to discriminate between an acoustic signal and background noise, determining the frequency range to which certain species respond. The lateral sense organ (responsive at lower frequencies) as well as the fish ear itself is receiving attention by a number of investigators.

The Japanese have formally recognized the importance of sound in their aquaculture program and have carried out research on the response of fish to acoustic stimuli. A bulletin of the Okayama experimental fisheries station in Japan discusses the tracking with acoustic tags of fish that have been conditioned through use of food and sound. Investigators in other countries have acoustically conditioned fish, too.

In the future, we may see something closer to open-sea fish farming. If our understanding of fish behavior is enhanced, acoustics will serve, along with many other tools, to permit meaningful control of this vital resource.

Paul T. McElroy is a scientist carrying out research in underwater acoustics at Bolt, Beranek, and Newman, Inc., Cambridge, Massachusetts.

Suggested Readings

- Breder, C. M. 1959. Studies of social groupings in fishes. *Bull. Am. Mus. Nat. Hist.* 117:397-481.
- Cushing, D. 1973. *The detection of fish*. N.Y.: Pergamon Press.
- Food and Agriculture Organization of the United Nations. 1966. *Manual of sampling and statistical methods for fisheries biology. Part 1. Sampling methods*. Rome: FAO.
- Forbes, S. T. and O. Nakken, eds. 1972. *Manual of methods for fisheries resource survey and appraisal. Part 2. The use of acoustic instruments for fish detection and abundance estimation*. Rome: FAO.
- Gulland, J. A., ed. 1969. *Manual of methods for fish stock assessment, Part 1. Fish population analysis*. Rome: FAO.
- McElroy, P. 1977. How can the methodologies of pattern recognition aid in modeling volume reverberation processes? In *Ocean sound scattering prediction*, Neil Anderson, ed., vol. 5. Marine-Science Series. N.Y.: Plenum Press.
- Radakov, D. V. 1972. *Schooling of fish as an ecological phenomenon*, B. P. Manteifel, ed. Moscow: Izdatel'stov "Nauka".
- Tucker, D. G. 1967. *Sonar in fisheries — A forward look*. London: Fishing News Books Ltd.

Acoustics and Submarine Warfare

by Robert W. Morse

In the two great wars of this century, German submarines were nearly decisive against the Atlantic maritime powers. Indeed, the victors after each war wondered if they had solved the challenge of submarines. At the time, of course, they did. But these were not neat or simple triumphs. Supremacy over the submarine was secured only after great losses and an enormous expenditure of ingenuity, patience, and resources.

Although submarines have not been used in a war at sea since 1945, nothing has happened to diminish our apprehensions of the threat that submarines can pose to free use of the seas. In the intervening years, the Soviet Union has operated a peacetime submarine force of unprecedented magnitude. They have 330 submarines, or three times the number operated by the United States (Figure 1). More than thirty other nations possess submarines, for a total of about 300. In recent years, technological advances have added radically new dimensions to the potential submarine threat. Nuclear power has given submarines greatly increased underwater speeds and endurance. With ballistic missiles armed with nuclear warheads, submarines now can threaten inland cities as well as maritime targets.

Seawater provides an effective cloak for a submerged submarine. Not only is visible light rapidly attenuated in seawater, but all forms of

*The underwater firing of a Polaris A-3 missile by a submarine.
(Courtesy U.S. Navy)*



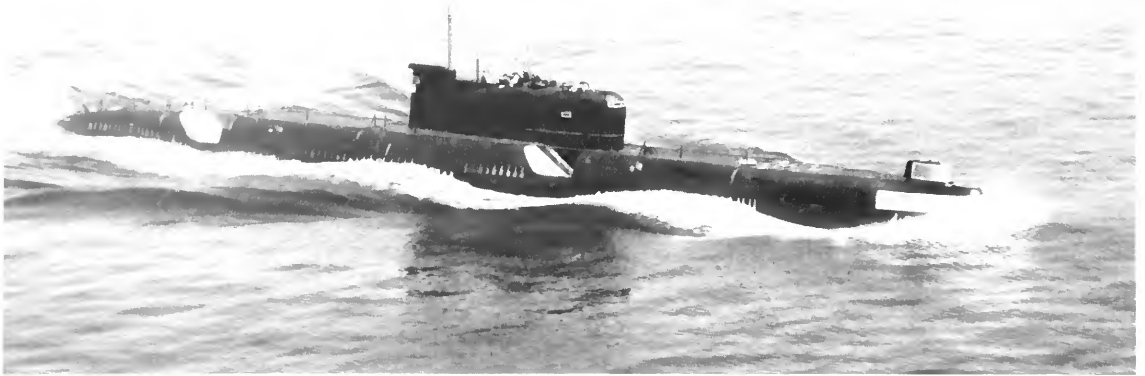

Figure 1. A Soviet J Class guided-missile submarine underway off the coast of Spain. (Courtesy U.S. Navy)

electromagnetic radiation, such as radar or radio waves, are heavily absorbed. Even under the best of circumstances, the practical penetration of electromagnetic radiation in seawater can be measured in tens of meters. The submarine, however, has properties that may give away its presence. For example, a submarine is made of steel, giving off a detectable magnetic field. The strength of this field, though, falls off rapidly with distance (detection ranges are measured in hundreds of meters), and so has limited military value.

Practical experience and the laws of physics show that acoustics is the best tool for detecting submerged submarines at militarily useful distances — thousands of meters or more. Submarines emit sounds as they propel themselves through the water, and even quiet submarines reflect sounds directed at them.

In the battles of the Atlantic in both World Wars, large numbers of submarines were deployed in a war of attrition against the sea lanes of maritime powers. Whether or not this particular circumstance is likely to arise in the future is unknown. The important fact of both wars was that a large number of submarines were employed to deny the use of the seas, and this challenge became central to the outcome of the war.

World War I

The importance of submarines in World War I was a surprise to both sides. Prior to the war, the submarine was considered an experimental and hazardous vehicle. It was small, had a limited range, and was generally thought to have a role only in coastal defense. The German Navy was the last of the great navies to introduce the submarine to its

fleet. Its first submarine, a small and unsuccessful boat, was launched only five years before the beginning of the war.

The technical innovation that created the modern submarine was the diesel engine, in combination with battery power. The diesel provided efficient, long-range surface cruising, while batteries allowed quiet, submerged operations during approach and attack. The first diesel-electric submarine of the German Navy was not completed until about a year before the outbreak of the war.

Thus, at the outset of the war, the Germans had created a new “weapon system” without being aware of its great potential. This changed rapidly after the first few submarines were put into the hands of daring naval officers, who ranged far afield early in the war. They used their vessels with surprising effect against combat vessels.

The Germans soon realized the advantages of the submarine as a weapon against merchant shipping — at that time essential to the life of the British Isles and the maintenance of the war in Europe. By the spring of 1917, unrestricted U-boat warfare was at its peak, a campaign that brought the United States into the conflict. In April 1917, when the Germans had about 25 U-boats at sea, nearly 900,000 tons of merchant shipping was sunk. The British alone lost 155 ships that month. Of every 100 ships that attempted to land cargo in England, 25 were sunk in the process.

The most significant antisubmarine warfare innovation that turned the tide was a tactical one — the introduction of convoys. This began in the spring of 1917, after much debate. The use of convoys dramatically decreased the number of ships sunk (by about a factor of ten) because it forced the

U-boat to fight in the presence of escorts. The only significant technical advance at that time was the development of the depth charge, a weapon more valuable for its psychological effect on the submarine's crew than for its deadliness.

During the war, submarine detection by acoustic means was employed, but its use was not decisive. The acoustic devices of the time used passive listening from the escort ships equipped with hydrophones in their hulls; the sailor used his binaural sense (utilizing a pair of trainable hydrophones — one to each ear) to determine the submarine's bearing (see page 13). Such instruments could not be used while underway because of the ship's self-noise. The processing of any signal was done by the individual mariner, using his own ears to determine direction (Figure 2).

At the end of the war the directions antisubmarine warfare would take in the future were defined, if not solved. It was recognized that acoustics promised the best means for detecting submarines. Echo ranging by piezoelectric transducers had been invented and demonstrated by Paul Langevin in France (see page 12). The potential of patrol aircraft for detection and attack was also recognized, having already been used with limited success.

The use of acoustics was limited during the First World War because there was no adequate technology for converting acoustical signals to electrical ones and *vice versa*. While the discovery of piezoelectricity* was important, its full application required the development of vacuum-tube technology. This emerged in the decade after the war.

World War II

Although there was no radical improvement in submarine performance during the twenty-odd years between World War I and II, there was a maturing of many engineering technologies. The boats became tougher, faster, and of longer range; but they still spent most of their time on the surface. Progress in antisubmarine warfare was not spectacular either. In England, echo-ranging equipment (given the acronyms ASDIC by the British and SONAR by the Americans) was developed, and by 1939 most British antisubmarine

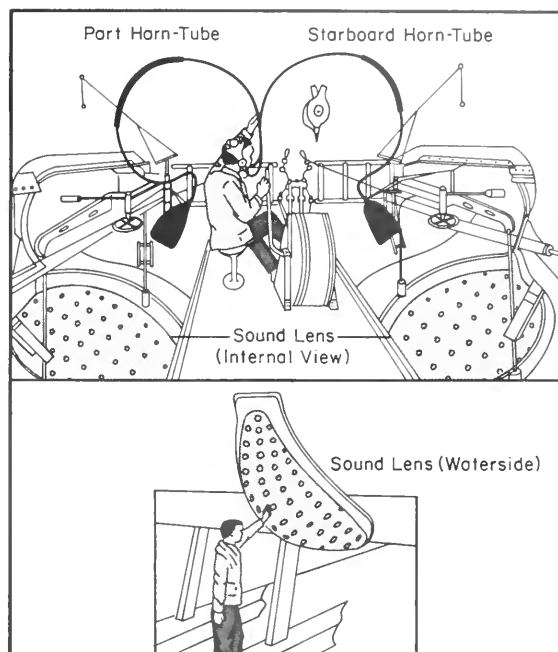

Figure 2. A shipboard binaural listening system as installed about 1915. (Courtesy Marvin Lasky/The Journal of the Acoustical Society of America)

craft were fitted out with this equipment. In the United States, the development of antisubmarine warfare detection equipment had been largely a low-level effort carried out mainly by the Naval Research Laboratory. Prior to the war, sonar sets were installed in only a few destroyers.

Antisubmarine warfare in World War II started off largely in the same balance as at the end of the previous war. Neither side was entirely prepared for what was to come. In the war's first year, the British pretty much had the upper hand. The combination of convoys, aircraft patrols, and the ASDIC gear effectively held off conventional daylight attacks by the small number of German submarines. This superiority did not last long. The Germans soon launched night attacks on convoys, introduced wolf-pack techniques, and sent their submarines on long-range cruises to the Western Atlantic. As the war proceeded, technical innovations played an important role in the Atlantic undersea war (Figure 3). The development of airborne radar to hunt submarines, and the equipping of aircraft with depth bombs and sonobuoys were significant antisubmarine tactics. The Allied monopoly on ten-centimeter radar (due to the invention of the magnetron) and the German's inability to intercept that wavelength gave Allied aircraft an important advantage in surprising and

*The ability of certain crystals, notably quartz, to vibrate when subjected to an alternating electrical field. The effect is also reversible and so an electrical signal can be created by the vibrational action of a sound wave. Thus, a single "transducer," which is a mosaic of such crystals, can be both a source and receiver of underwater sound.

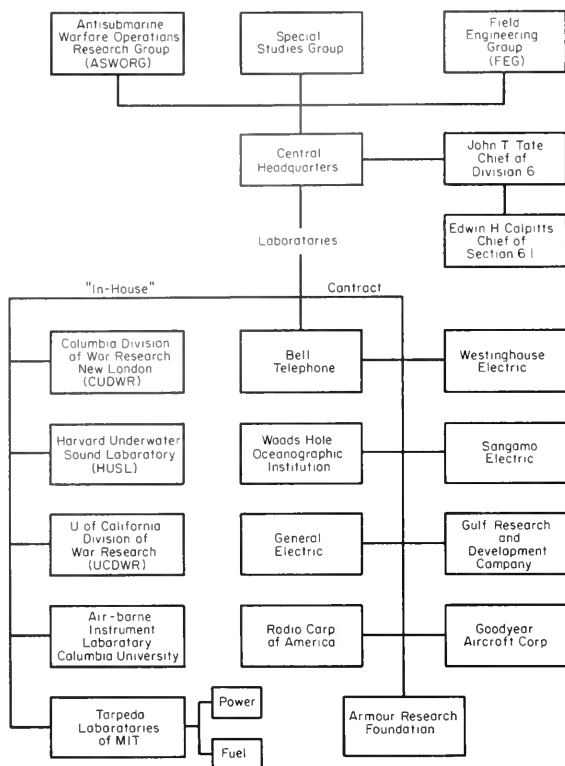

Figure 3. The organization of Division 6 for "Undersea Warfare" from 1941 to 1945 under the National Defense Research Committee. (Courtesy Marvin Lasky/The Journal of the Acoustical Society of America)

sinking submarines. German submarines were required to report home on a regular basis and these communications were monitored by the Allies through the use of high-frequency direction-finding equipment, which provided a large intelligence advantage. Meanwhile, merchant convoys were given escort aircraft carriers, which provided air cover over the entire route.

The effectiveness of surface escort vessels was greatly increased by improvements in shipboard sonar, in antisubmarine weapons, and in understanding oceanographic factors. It was found, for example, that the World War I depth charge did not function well with the new sonars. Not only did the explosion of depth charges inevitably result in loss of sonar contact, but the submarine could escape during the considerable time it took for a depth charge to fall to the required depth. New "ahead-thrown" weapons were developed. These consisted of a pattern of small projectiles fired ahead of the escort ship. Because of streamlining, they fell through the water much faster than a depth charge. Sonar contact could be maintained during attacks

because they exploded only when they hit the submarine. This meant there was less time for the submarine to use evasion tactics, and an explosion was a direct indication of probable damage. Thus, the surface escort ship was made into a more effective antisubmarine "system."

At the same time, improvements were being made in the submarine's capabilities, such as pattern running and homing torpedoes; and, in the late stages of the war, the "snorkel," which allowed a submarine to run submerged on its diesel engines. The snorkel (a Dutch invention) was a float-valve device that the submerged submarine could raise above the surface of the ocean, allowing the diesel engine to "breathe" without swallowing water. Since the snorkel was difficult to detect by radar, its introduction greatly reduced the vulnerability of the cruising submarine to attack by aircraft.

The Role of Oceanography

Oceanography was an important tool in defeating the submarine in the battle to control the Atlantic. Acoustic propagation, and hence the performance of sonars, was found to depend heavily on the local, vertical temperature structure of the ocean. Just prior to World War II, a simple and reliable instrument for measuring this, the bathythermograph, had been invented by Athelstan Spilhaus at the Woods Hole Oceanographic Institution. The bathythermograph became a key tool in estimating sonar performance (Figure 4). But understanding the ocean also worked to the submarine's advantage, as the U.S. Navy discovered in its Pacific operations. There, the situation was reversed from the Atlantic in that the United States deployed a large fleet of submarines in a war of attrition against the Japanese. The success of the U.S. Navy's submarine offensive in the Pacific was partly due to scientific and technical lessons learned from fighting the war in the Atlantic.

While it is obvious that scientific advance played an important role in the defeat of the German submarine in World War II, a careful reading of the history of that war makes it clear that non-technical factors were equally significant. Proper tactics and good training, for example, were found to be prerequisites to success. The record of the ups and downs of antisubmarine warfare in World War II is as much a function of the number of available forces as it is of specific technical advances. Numbers of forces and the skill with which they were used was basically the difference between the summer of 1942 and the summer of 1944.

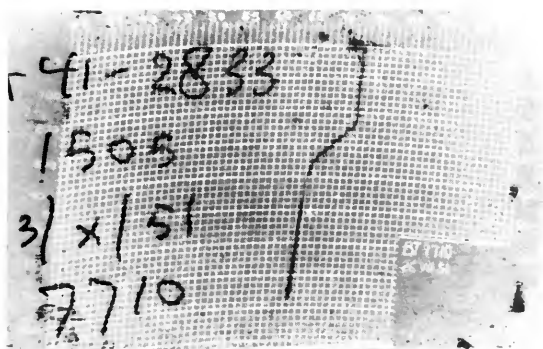

Figure 4. A bathythermograph, or BT, with a typical record. The horizontal scale is temperature, the vertical depth. The notations indicate the cruise and time of measurement. The record shows a mixed layer at the surface.

In the summer of 1942, the Germans had about 350 submarines at sea, with an average life expectancy of thirteen months. These vessels accounted for the loss of nearly 500,000 tons of shipping per month (Figure 5). Less than two years later, the Germans had 400 submarines at sea, but their life expectancy had dropped to four months. Total shipping sunk had decreased to 100,000 tons per month. In that latter period, the German submarine was clearly defeated; the exchange ratio at the height of Allied success was two submarines for each surface ship sunk. In total, the Germans lost 781 submarines in World War II.

A healthy conclusion to remember is that the outcome of submarine warfare depended on many factors other than technical innovation. It is erroneous to think that scientific discovery very often has revolutionary impacts. More often, the effects of science and technology permit improvements in what is already being done in a variety of quite specific and limited ways. Over a period of time, such improvements can represent a significant advance. Progress in antisubmarine warfare has been made in this way. No single advance has represented a "solution." Those admirals who have demanded a breakthrough by scientists have nearly always been disappointed. This is because submarine warfare has always been a game of hide-and-seek in a very confusing forest; it is not just measure and countermeasure masterminded by scientists. The antisubmarine side usually has had to muddle through. The general rule has been equipment that works only under some conditions or in some places, and then only when the submarine does what is expected.

The most significant applications of acoustics in World War II were in the use of active sonars carried on escort ships, and of passive sonobuoys dropped by aircraft. Both of these acoustic systems had quite limited ranges. Surface escorts, using active sonar under ideal conditions,

had detection ranges of a few thousand meters. The performance of sonar was found to depend on the thermal structure in the top layers of the ocean and this, of course, is variable, depending on season, weather, and location. If the submarine is in a constant-temperature, reasonably deep, mixed layer near the ocean's surface, then there are direct ray

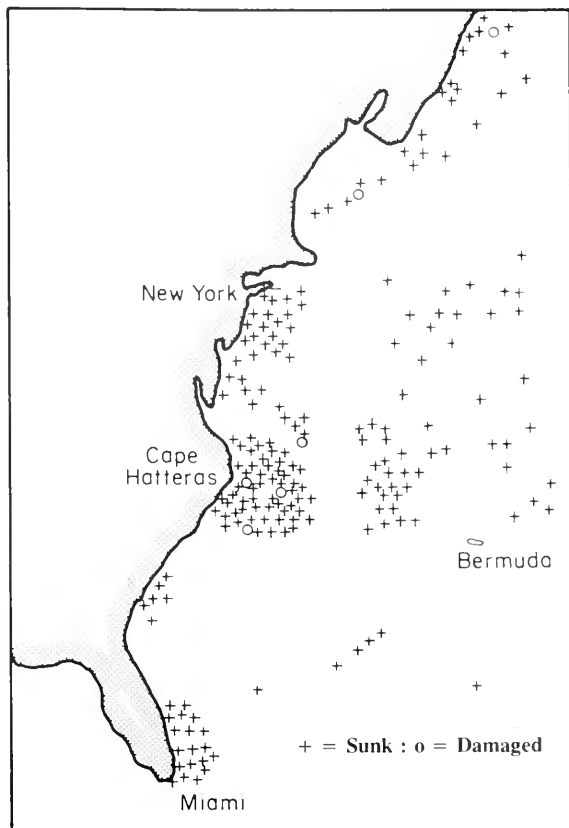

Figure 5. Merchant shipping sunk by German U-boats off the Atlantic coast from January to July, 1942. (Courtesy Marvin Lasky/The Journal of the Acoustical Society of America: Source — German naval history series, *The U-boat War in the Atlantic*, Vol. 1939-41)

paths between the sonar and the target, and good detection can be expected. If the submarine lies in the thermocline below the mixed layer (or if a layer does not exist), the submarine, except at close range, will be in a "shadow zone" where sound does not penetrate significantly. When a submarine hid in such a zone, the effective range of a World War II sonar was reduced to hundreds of meters; more often than not useful detection was impossible. It also was found that sonar performance depended on many other factors: the sea state, the presence of biological life, the speeds of both submarine and surface ship, and the orientation of the submarine.

Most of the sonar limitations in World War II were unavoidable because they were due to fundamental aspects of the ocean. Success at that time resulted primarily from learning to live with these realities. In circumstances where performance was variable, prediction became important. The ability to estimate sonar performance, for example, was critical in designing an escort screen or in laying out a convoy route. Thus, a thorough understanding of oceanography was required to get the most out of sonar.

Nuclear-Powered Submarines

There have been profound changes in submarines since the last German one was sunk off Block Island in May, 1945 by a destroyer-escort group. These changes are a consequence of the introduction of nuclear propulsion, an innovation pioneered by Admiral Hyman Rickover. The Nautilus was the first true submarine; all prior ones were submersible surface ships (Figure 6). Nuclear power permitted continuous submerged operations. Moreover, high underwater speeds could be attained because the hull could be streamlined and did not have to be designed for efficient surface running. In one stroke, nuclear power provided a submarine of practically unlimited range, with little dependence on the surface, and capable of sustained submerged speeds greater than those of many antisubmarine surface ships.

Because the U.S. Navy pioneered in the development of nuclear submarines, they have been particularly sensitive to the threats such submarines pose. In this regard, I cannot help but recount a personal experience in 1956 with a summer study in Woods Hole called "Project Nobska." It was sponsored by the National Academy of Sciences and was chaired by Columbus Iselin, then the Director of the Woods Hole Oceanographic Institution. The study drew some sixty scientists and engineers from throughout the country.

The task set for the group by Admiral

Arleigh Burke, the Chief of Naval Operations, was to recommend what the Navy's future response should be to the challenge of nuclear submarines. The summer study organized itself into five groups; I was given the assignment of chairing the group dealing with possible defenses against nuclear submarines. It became apparent early in Project Nobska that the ultimate threat from nuclear submarines would come if they could be armed with long-range, ballistic missiles. Following up this idea, the summer study then proceeded to write what soon turned out to be a draft set of specifications for the Polaris submarine fleet. To do that, we had to establish that solid-fuel rockets of the requisite accuracy and reliability were feasible, that a totally submerged submarine could navigate with sufficient accuracy, and that positive command could be exercised over a fleet of submerged submarines operating far from home. Most of the energy and excitement of that summer inevitably centered on trying to see if technology would allow such requirements to be met. Needless to say, my task group, which had to describe a feasible defense against this hypothetical system, had to stretch its collective imagination pretty far.

That fall a few of us reported the results of Project Nobska to a group of admirals assembled in the old hall of the National Academy of Sciences. My report on possible defensive systems followed the dramatic one describing the technical feasibility of a fleet of nuclear-powered, missile-launching submarines. I rose to speak with that sinking feeling an actor must have when he knows his script is a loser.

Ironically, Project Nobska, which had been convened to find new ways to defend against nuclear submarines, had instead demonstrated the possibility of a quantum increase in their offensive capability. It seems in warfare that the race between offense and defense is often like the race between the hare and the tortoise. Offense moves by periodic, innovative leaps. Defense, like the tortoise, is a much slower and duller animal. The development of the missile-carrying, nuclear submarine was a great leap forward in military offensive capability. Would the tortoise ever be able to catch up?

Response to Nuclear Submarines

After the introduction of nuclear submarines, acoustics acquired a more central role in antisubmarine measures. No longer could one count on finding submarines on the surface. Acoustics,

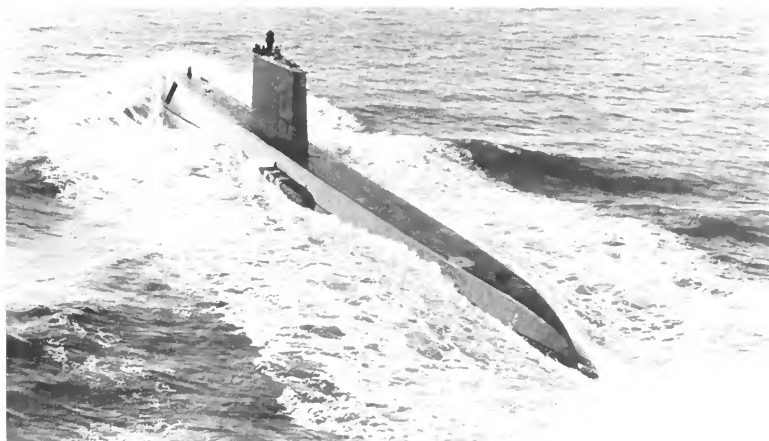

Figure 6. The USS Nautilus, during sea trials. (Courtesy U.S. Navy)

therefore, was the only phenomenon that could propagate in the ocean to useful ranges. Although the sonar systems of World War II were nearly useless against nuclear submarines, the research in underwater acoustics that had transpired during and after the war indicated several promising directions for future systems. For example, it was realized after the war that the sound refracted downward by the thermocline eventually could reappear in the surface layers; either by sound being reflected off the ocean bottom, or by the inevitable upward refraction that occurs in deep water. If such acoustic paths could be used, echo ranging might be feasible out to the first "convergence" zone,* a distance of some 50 kilometers. This was not possible with the sonars used in World War II. Lower frequencies and much higher acoustic powers would be required for echo-ranging systems at such distances. New developments were launched along these promising lines.

An important result of World War II research was the so-called SOFAR channel discovered by Maurice Ewing and Joseph Worzel working at the Woods Hole Oceanographic Institution. Because of its dependence on temperature and pressure, the velocity of sound in the sea reaches a minimum value at an average depth of about 1,260 meters in the North Atlantic. Such a minimum creates the possibility of a sound "channel." It was discovered that sound signals set off near the velocity minimum were guided for long distances, even thousands of kilometers. It was proposed that this phenomenon could be used for locating aviators downed at sea. If the downed crewmember dropped a small explosive charge designed to detonate at the axis of the sound

channel, his location could be fixed from signals picked up at shore stations. Although this system was never implemented, experiments with the deep sound channel showed that long-range acoustic propagation was possible, and that the deep ocean was a much more predictable acoustic medium than the shallow surface layers.

Although the advent of the nuclear submarine caused many defensive headaches, there were some helpful by-products. The most important was that the submarine itself proved to be an excellent acoustic platform. Nuclear submarines could be equipped with large, passive listening arrays and lie in wait for unsuspecting submarines. The fear of such ambush is an inhibiting prospect for any submarine skipper. Also, their ability to run deep at high speeds is a mixed acoustic blessing. Such a submarine not only radiates more noise and thus becomes easier to detect, but its own ability to listen is decreased.

Antisubmarine warfare measures have been pursued aggressively in the United States during the last twenty years. While it is not possible to discuss the technical details of such systems here, certain general directions can be indicated. Consistent with the lessons learned in both wars, no single approach has emerged as the dominant solution. A given antisubmarine system usually has significant effectiveness only in some particular range of circumstances. The overall solution, therefore, has been sought in a combination of several approaches where the deficiencies of one system can be compensated by advantages of another. For example, aircraft are valuable for antisubmarine detection because of their speed; they are, however, undependable in bad weather and are not directly coupled acoustically to the ocean. In contrast, submarines are not affected by weather and are ideal platforms for large acoustic listening

*The distance at which deep sound rays (paths) from a shallow source come to a focus at the surface.



Figure 7. A Sea King helicopter lowering a sonar device during antisubmarine maneuvers in the Western Pacific. The helicopter is from the aircraft carrier USS Hornet. (Courtesy U.S. Navy)

arrays. Thus, submarines and aircraft are useful in different ways. Submarines are well-suited to a barrier-type mission designed to intercept transiting submarines. Aircraft, however, can quickly follow up a distant contact or sighting; they can also monitor surface shipping in a large ocean area and thus force submarines to run beneath the surface.

Many vehicles play useful roles in antisubmarine warfare. Surface ships, aircraft, submarines, manned and unmanned helicopters are all employed, often in combination (Figure 7). There are systems, such as mines, or bottom-located listening systems, that do not involve a vehicle at all. The most sophisticated of the mines is a moored capsule that can release an acoustic homing torpedo when a submerged submarine passes within range. In wartime, a field of such mines could create an antisubmarine barrier at much less cost than a submarine barrier.

The ranges at which acoustic systems can detect submarines have been extended well beyond those attainable at the end of World War II. This has been accomplished in several ways: by going to lower frequencies where attenuation is lower, by making systems larger in size and power, by using more effective data-processing techniques, and by the application of new knowledge gained from research in ocean acoustics. New antisubmarine weapons also place heavy reliance on acoustics. The principal weapon is the homing torpedo, which carries its own passive and active sonars to search out and attack submerged submarines. Modern electronic technology now makes it possible for such torpedoes to carry sonar systems, (with built-in decision making) that are more complex than those used on World War II destroyers.

It is not easy to estimate how effective modern antisubmarine warfare systems would be against nuclear submarines. Not only are there a variety of systems, but we know from past experience that the balance is swung by such factors as the number of available forces and their state of training. If there were to be a war of attrition at sea (a scenario that is not too plausible in the nuclear age), one would guess that the technical advances in antisubmarine warfare of the last twenty-five years have probably about balanced out the advantages of nuclear propulsion. Thus, the tortoise has moved, with respect to the hare, at least in the traditional race. But the missile-launching submarine cannot be viewed in traditional terms.

The Deterrence Mission

The addition of ballistic missiles with nuclear warheads created an entirely new strategic role for submarines. The function of such a fleet is to prevent war by threatening massive destruction to land-based populations, a mission entirely beyond the traditional naval task of controlling the seas. Thus, Polaris-type submarines have no historical counterpart; they are products of the nuclear age. Such submarines have become essential elements in support of our basic nuclear defense doctrine of "deterrence." The concept of deterrence relies on the assumption that no nation will contemplate a nuclear attack on another if such an act inescapably brings destruction to itself. It is significant that the recent strategic arms limitation discussions (SALT talks) are based on the mutual acceptance of this concept by both the United States and the Soviet Union.

An artist's concept of the USS Ohio, the first of the Navy's new Trident-class submarines. It is scheduled to be deployed some time in 1979. This class will carry missiles of longer range than the current Polaris-class submarines, enabling them to range over wider areas of the ocean. (Courtesy General Dynamics/Electric Boat)

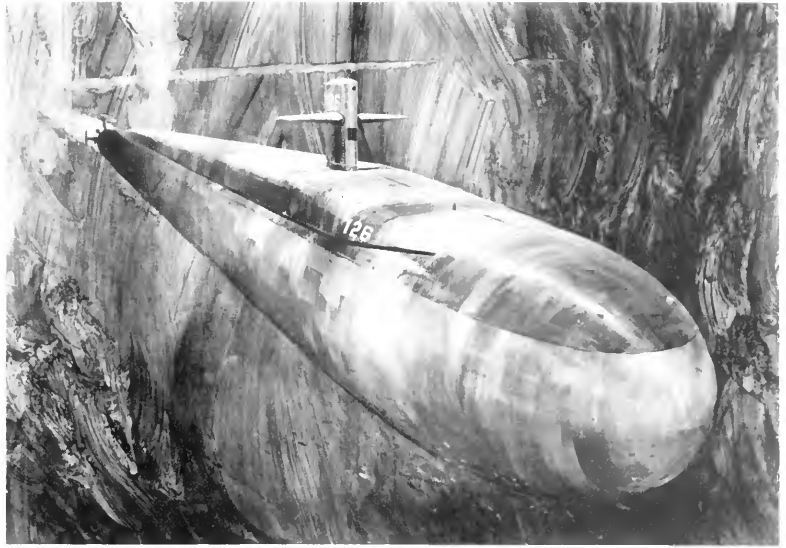

The cornerstone of national security in a world dependent on mutual deterrence is the confidence that one can, if required, cause unacceptable damage to the other side no matter what else happens. Ballistic missile submarines have been recognized by both the United States and the Soviet Union as providing a retaliatory system that is enormously difficult to destroy by surprise and therefore capable of filling a substantial part of the nuclear deterrence mission.

Antisubmarine measures have entirely different implications for the strategic mission of deterrence than with the traditional mission involving the use of the seas. The logic of deterrence requires the inversion of the meaning of "offensive" and "defensive" as they would be judged in conventional military language. Within its special logic, the aggressive development of antiballistic missile systems, civil defense programs, or certain antisubmarine systems cannot be viewed as benign defensive measures. These can only be seen, by the other side, as offensive actions, since they have the effect of reducing that side's ability to deter. All such moves imply that one accepts nuclear war as a rational possibility.

In a world of nuclear weapons, the paramount defense question is confidence in the survivability of retaliatory weapons, even if there is a surprise attack. Such confidence requires that the submarine-based deterrent systems be relatively invulnerable into the foreseeable future. In turn, this requires confidence that antisubmarine systems are never going to be very effective!

The antisubmarine task of frustrating a retaliatory attack by a fleet of missile-launching submarines is enormously more difficult than defeating submarines in a war of attrition against merchant ships. (I did not realize at the time of Project Nobska that defense against such submarines is based on deterrence and not on antisubmarine measures.) Vulnerability for a submarine-based missile system must be defined in terms of a broad counteraction that prevents the entire system from its mission of retaliation. This means that about twenty evading nuclear submarines, scattered over millions of square miles in two or three oceans, would have to be made inoperative within a few minutes.

Although there is little doubt that current antisubmarine systems do not constitute a threat to the invulnerability of sea-based deterrence systems, the question of the detection and tracking of submarines by acoustic systems in the future has taken on a new significance. It is obvious that the very basis of national security for some years to come will depend on our knowing what can and cannot be done with underwater acoustics.

A former Assistant Secretary of the Navy for Research and Development, Robert W. Morse is Dean of Graduate Studies and an Associate Director of the Woods Hole Oceanographic Institution.

Oceanus[®] Back Issues

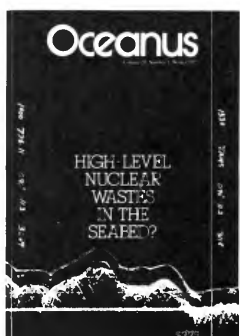
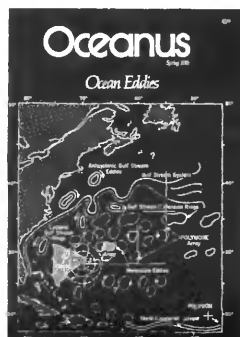
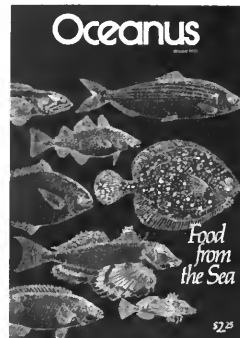



Back Issue Contents

SEA-FLOOR SPREADING, Winter 1974—Plate tectonics is turning out to be one of the most important theories in modern science, and nowhere is its testing and development more intensive than at sea. Eight articles by marine scientists explore continental drift and the energy that drives it, the changes it brings about in ocean basins and currents, and its role in the generation of earthquakes and of minerals useful to man.

AIR-SEA INTERACTION, Spring 1974—*Very limited supply.*

ENERGY AND THE SEA, Summer 1974—One of our most popular issues. The energy crisis is merely a prelude to what will surely come in the absence of efforts to husband nonrenewable resources while developing new ones. The seas offer great promise in this context. There is extractable energy in their tides, currents, and temperature differences: in the winds that blow over them; in the very waters themselves. Eight articles discuss these topics, as well as the likelihood of finding oil under the deep ocean floor and of locating nuclear plants offshore.

MARINE POLLUTION, Fall 1974—Popular controversies, such as the one over whether or not the seas are "dying," tend to obscure responsible scientific effort to determine what substances we flush into the ocean, in what amounts, and with what effects. Some progress is being made in the investigation of radioactive wastes, DDT and PCB, heavy metals, plastics and petroleum. Eleven authors discuss this work, as well as economic and regulatory aspects of marine pollution.

FOOD FROM THE SEA, Winter 1975—*Very limited supply.*

DEEP-SEA PHOTOGRAPHY, Spring 1975—*Out of print.*

THE SOUTHERN OCEAN, Summer 1975—*Very limited supply.*

SEAWARD EXPANSION, Fall 1975—We have become more sophisticated in the construction of offshore structures than most of us realize. Eight articles examine trends in offshore oil production and

Oceanus

The Illustrated Magazine
of Marine Science
Published by Woods Hole
Oceanographic Institution

SUBSCRIPTION ORDER FORM

Please make checks payable to Woods Hole Oceanographic Institution.
Checks accompanying foreign orders must be payable in U.S. currency and drawn on a U.S. bank.
(Outside U.S., Possessions, and Canada add \$2 per year to domestic rates.)

Please enter my subscription to OCEANUS for

- one year at \$10.00
- two years at \$18.00
- payment enclosed.
(we request prepayment)
- bill me

Please send MY Subscription to:

Please send a GIFT Subscription to:

Name (please print)

Street address

City State Zip

Name (please print)

Street address

City State Zip

Subscriber's occupation: _____

of five or more. We accept only prepaid orders. Checks should be made payable to Woods Hole Oceanographic Institution; checks accompanying foreign orders must be payable in U.S. currency and drawn on a U.S. bank. Address orders to: Oceanus Back Issues, Woods Hole Oceanographic Institution, Woods Hole, MA 02543.

Oceanus[®] Back Issues

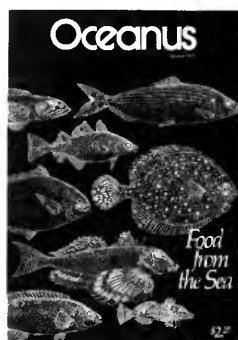

PLACE
STAMP
HERE

Oceanus

Woods Hole Oceanographic Institution
Woods Hole, Mass. 02543



Back Issue Contents

SEA-FLOOR SPREADING, Winter 1974—Plate tectonics is turning out to be one of the most important theories in modern science, and nowhere is its testing and development more intensive than at sea. Eight articles by marine scientists explore continental drift and the energy that drives it, the changes it brings about in ocean basins and currents, and its role in the generation of earthquakes and of minerals useful to man.

AIR-SEA INTERACTION, Spring 1974—*Very limited supply.*

ENERGY AND THE SEA, Summer 1974—One of our most popular issues. The energy crisis is merely a prelude to what will surely come in the absence of efforts to husband nonrenewable resources while developing new ones. The seas offer great promise in this context. There is extractable energy in their tides, currents, and temperature differences; in the winds that blow over them; in the very waters themselves. Eight articles discuss these topics, as well as the likelihood of finding oil under the deep ocean floor and of locating nuclear plants offshore.

MARINE POLLUTION, Fall 1974—Popular controversies, such as the one over whether or not the seas are "dying," tend to obscure responsible scientific effort to determine what substances we flush into the ocean, in what amounts, and with what effects. Some progress is being made in the investigation of radioactive wastes, DDT and PCB, heavy metals, plastics and petroleum. Eleven authors discuss this work, as well as economic and regulatory aspects of marine pollution.

FOOD FROM THE SEA, Winter 1975—*Very limited supply.*

DEEP-SEA PHOTOGRAPHY, Spring 1975—*Out of print.*

THE SOUTHERN OCEAN, Summer 1975—*Very limited supply.*

SEAWARD EXPANSION, Fall 1975—We have become more sophisticated in the construction of offshore structures than most of us realize. Eight articles examine trends in offshore oil production and its onshore impacts; floating oil ports; artificial islands; floating platforms; marine sand and gravel mining. National and local policy needs are examined in relation to the move seaward.

MARINE BIOMEDICINE, Winter 1976—Marine organisms offer exciting advantages as models for the study of how cells and tissues work under both normal and pathological conditions—study leading to better understanding of disease processes. Vision research is being aided by the skate; neural investigation, by the squid; work on gout, by the dogfish. Eight articles discuss these developments, as well as experimentation involving egg-sperm interactions, bioluminescence, microtubules, and diving mammals.

OCEAN EDDIES, Spring 1976—*Very limited supply.*

GENERAL ISSUE, Summer 1976—Articles range from a two-part series on the recent pollution problem in the New York Bight (delving into ocean-dumping policies and subsequent problems of research) to an analysis of the uses and cultivation of seaweeds. Other authors assess the relationship between seawater and the formation of submarine volcanic rocks and ore deposits, the "good old days" of marine geology, and the "antifreezes" in cold-water fishes.

ESTUARIES, Fall 1976—Of great societal importance, estuaries are complex environments increasingly subject to stress. The issue deals with their hydrodynamics, nutrient flows, and pollution patterns, as well as plant and animal life—and the constitutional issues posed by estuarine management.

HIGH-LEVEL NUCLEAR WASTES IN THE SEABED? Winter 1977—A group of scientists have spent more than three years studying aspects of isolating high-level radioactive wastes by burying them in the sub-seabed. Six articles describe highlights of their work, the overall problem of nuclear waste disposal, and the international political problems posed by a seabed option.

Limited quantities of back issues are available at \$3 a copy; a 25 percent discount is offered on orders of five or more. We accept only prepaid orders. Checks should be made payable to Woods Hole Oceanographic Institution; checks accompanying foreign orders must be payable in U.S. currency and drawn on a U.S. bank. Address orders to: Oceanus Back Issues, Woods Hole Oceanographic Institution, Woods Hole, MA 02543.

