





REGULATIONS FOR THE LIBRARY  
OF THE  
**Massachusetts Horticultural Society,**  
ADOPTED 1861.

ARTICLE I.

All Books, Manuscripts, Drawings, Engravings, Paintings, Models, Furniture, and other articles appertaining to the Library, shall be confined to the special care of the Committee on the Library.

ARTICLE II.

When any books or publications are added to the Library, a list thereof shall be posted up in the Library Room, and all such additions shall be withheld from circulation for the term of one month.

ARTICLE III.

The following Books of Record shall be kept:—

- No. 1. A Catalogue of the Books.
- No. 2. A Catalogue of the Manuscripts, Drawings, Engravings, Paintings, Models, and all other articles.
- No. 3. A list of all Donations, Bequests, Books, or other articles presented to the Society, with the date thereof, and the name and residence of the donor.

ARTICLE IV.

Rare and costly books shall not be taken from the Library Room. A list of such works as are to be withheld from circulation shall be made out from time to time by the Library Committee, and placed in the hands of the Librarian.

ARTICLE V.

No more than two volumes shall be taken out by any member at one time, or retained longer than three weeks; and for each volume retained beyond that time a fine of ten cents per week shall be paid by the person so retaining it. And a fraction of a week shall be reckoned as a whole week in computing fines.

ARTICLE VI.

Every Book shall be returned in good order (regard being had to the necessary wear thereof with proper usage), and if any Book shall be lost or injured, the person to whom it stands charged shall, at the election of the Committee on the Library, replace it by a new volume or set, or pay for it at its value to the Society.

ARTICLE VII.

All Books shall be returned to the Library for examination on or before the first Saturday in July, annually, and remain until after the third Saturday of said month, and every person neglecting to return any Book or Books charged to him as herein required, shall pay a fine of twenty cents per week, for every volume so retained. And if at the re-opening of the Library, any Book shall still be unreturned, the person by whom it is retained shall pay for the said Book or set, as provided in Article VI, together with any fines which may have accumulated thereon; and a notice to this effect shall be forthwith mailed to him by the Librarian.

ARTICLE VIII.

No member shall loan a book to any other person, under the penalty of a fine of \$1.00.

ARTICLE IX.

When a written request shall be left at the Library for a particular Book then out, it shall be retained for the person requiring it, for one week after it shall have been returned.

ARTICLE X.

Every book shall be numbered in the order in which it is arranged in the Books of Record, and also have a copy of the foregoing regulations affixed to it.



PRESENTED

TO THE

Massachusetts Horticultural Society,

BY

The Publisher

1895 - 1897.














Digitized by the Internet Archive  
in 2017 with funding from  
IMLS LG-70-15-0138-15

<https://archive.org/details/parkcemetery5618unse>



PARK AND CEMETERY  
VOLUME V.

---

March, 1895—February, 1896.

---

R. J. HAIGHT, Publisher.

CHICAGO.



# INDEX.

- \*A Columbarium, Indianapolis, Ind. . . . . 190  
 A Few words from a Landscape Gardener . . . . . 74  
 \*A Flower Bed at Girard College, Philadelphia. . . . . 83  
 \*A Greenland Cemetery. . . . . 78  
 \*American Cemeteries are Pagan. . . . . 57  
 \*An Algerian Fountain. . . . . 210  
 A New Wisconsin Cemetery Law. . . . . 139  
 \*A pretty Cemetery in England. . . . . 154  
 Arboretum, Puget Sound University. . . . . 209  
 A Town can accept a Bequest for Improving Cemetery. . . . . 49  
 Authority to Disinter Bodies. . . . . 212
- Botanical Gardens. . . . . 110  
 \*Botanic Garden, Buffalo, N. Y. . . . . 76
- Care of Forest Trees. . . . . 103  
 Carpet Beds in Parks. . . . . 59  
 \*Cemetery of Spring Grove, Cincinnati, O. . . . . 4  
 Cemeteries and Cremation. . . . . 114  
 Cemetery Accounting. . . . . 99, 122, 143, 160  
 \*Cemetery Greenhouses. . . . . 11, 29, 45, 68, 82, 101  
 Cemetery Law for Oklahoma . . . . . 147  
 Cemetery Law. . . . . 194  
 Cemetery Notes. . . . . 16, 34, 52, 70, 88, 106, 124, 160, 178, 196, 214  
 Cemetery Reports. . . . . 18, 35, 53, 71  
 City Parks. . . . . 175  
 \*Columbia Park, Lafayette, Ind. . . . . 39  
 \*Confederate Monument, Chicago. . . . . 67  
 Constitutional Right to construct Highways through Cemeteries . . . . . 67  
 Contract of Purchase must be in Writing . . . . . 103  
 Convention Notes. . . . . 136  
 Correspondence. . . . . 17, 35, 71, 89, 107, 125, 179, 197, 215  
 County Parks. . . . . 128  
 Costly Burial Grounds at Franklin, Mass. . . . . 48  
 \*Crapo Park: Burlington, Ia. . . . . 201  
 Cycling in the Parks. . . . . 38  
 Cremation. . . . . 71, 125  
 \*Crowded Cemeteries of London. . . . . 211  
 Curious Funeral Rites. . . . . 89
- \*Dellwood Cemetery, Manchester, Vt. 42
- Early Mourning Customs in New England. . . . . 50  
 \*East Linwood Cemetery, Boone, Ia. . . . . 208  
 Editorial, 1, 19, 37, 55, 73, 91, 109, 127, 145, 163, 199  
 \*Elm Grove Cemetery, Mystic, Conn. 63
- \*Entrance to Forest Hill Cemetery, Fredonia, N. Y. . . . . 81  
 Epitaphs. . . . . 104, 140  
 Extracts. . . . . 108, 126  
 Fairmount Park Art Association. . . . . 191  
 \*Fern House, Horticultural Hall, Fairmount Park, Philadelphia. . . . . 98  
 \*Flowerbeds at Girard College, Philadelphia. . . . . 64  
 \*Foundations. . . . . 65  
 \*Franklin Park, Boston. . . . . 93  
 Garden Architecture. . . . . 134
- \*Gardening in Harmony Grove Cemetery, Salem, Mass. . . . . 121  
 \*Garden Plants—Their Geography. . . . . 148, 168, 184, 204  
 \*Golden Gate Park. . . . . 59  
 Good Bequests. . . . . 102  
 Gardening. . . . . 146  
 \*Groups of Weeping Hemlocks. . . . . 192  
 Guild of the Kew Gardeners. . . . . 158
- \*Hillsboro Cemetery, Hillsboro, O. . . . . 114  
 Horticultural Education—Practice and Theory. . . . . 155  
 How to make and Care for a Lawn. . . . . 24  
 How to Plant. . . . . 147
- \*Island Cemetery Receiving Tomb, Newport, R. I. . . . . 66
- \*Jackson Park, Chicago. . . . . 20
- Knowing How. . . . . 80
- Landscape Gardening. . . . . 92  
 Lichen and Mosses. . . . . 165  
 Lily Pond at Lincoln Park, Chicago. . . . . 129
- \*Memorial Chapel, Union Cemetery, Fairhaven, Conn. . . . . 96  
 Monotony in Gardens. . . . . 47
- Nature versus Art. . . . . 77  
 Nelumbiums. . . . . 14  
 Ninth Annual Convention of the A. C. S., Richmond, Va. . . . . 85  
 Notes. . . . . 86  
 Notes on English Parks. . . . . 174  
 Notes on the Rhododendron. . . . . 120
- \*Oak Grove Cemetery, Bath, Maine. . . . . 26  
 \*Oakwood Cemetery, Syracuse, N. Y. 188
- Park Building. . . . . 56  
 Park Construction. . . . . 38  
 Park Notes, 15, 33, 51, 69, 87, 105, 123, 141, 159, 177, 195, 213  
 Perpetual Care. . . . . 40  
 Planting of Grass. . . . . 28  
 Pointers for Cemetery Officials. . . . . 86  
 Practical Work in the Cemetery. . . . . 164, 200  
 Premature Burial. . . . . 149  
 Preserve Valuable Trees. . . . . 113  
 Proposed Park System for Essex County, New Jersey. . . . . 8  
 Pruning Trees in Summer Time. . . . . 49  
 Public Parks and Pleasure Grounds. . . . . 25  
 Public Parks and Reservations. . . . . 206  
 Publishers' Department, 18, 36, 54, 72, 90, 108, 126, 144, 162, 180, 198, 216
- \*Receiving Vault, Mt. Elliott Cemetery, Detroit, Mich. . . . . 202  
 \*Refectory Building, Franklin Park, Boston. . . . . 155  
 Reform in the Use of Bedding Plants. . . . . 31  
 Respect for the Dead. . . . . 203  
 Right of Administrator to Buy Place for Burial. . . . . 103  
 Rights in Cemetery Lots Purchased for Family Burial Places. . . . . 49  
 Roads. . . . . 96  
 Rolling Country. . . . . 13
- Rules and Regulations. . . . . 107, 197  
 \*Rustic Vases in Lincoln Park, Chicago. . . . . 112
- \*Salisbury Tower, Institute Park, Worcester, Mass. . . . . 32  
 \*Sculptured Monuments of Philadelphia. . . . . 152, 172  
 Seasonable Hints for Cemetery Superintendents. . . . . 180  
 \*Shelter House, Cave Hill Cemetery, Louisville, Ky. . . . . 44  
 \*Soldiers' Memorial, Oakwood Cemetery, Syracuse, N. Y. . . . . 84  
 Some Druidical Stones. . . . . 211  
 \*Stained Glass in Monumental Work. . . . . 186  
 Street Trees. . . . . 205  
 Swamp Plants in Dry Ground. . . . . 185  
 \*Swan Point Cemetery, Providence, R. I. . . . . 100
- Tam-na-Urich. . . . . 84  
 Taxation of Capital Stock of Cemetery Company. . . . . 139  
 \*Terrace Steps with Vases, Lincoln Park, Chicago. . . . . 202  
 The Arnold Arboretum, Boston, Mass. . . . . 193  
 \*The Bedding of Monumental Work. . . . . 79  
 The Cemetery Superintendents' Ninth Annual Convention. . . . . 116  
 \*The Greenwood Cemetery. . . . . 170  
 \*The Grotto, Forest Hills Cemetery, Boston. . . . . 9  
 \*The Hemlock Spruce. . . . . 40  
 \*The Himalayan Pine. . . . . 206  
 \*The Monumental Cemetery of Milan. . . . . 132  
 \*The National Cemetery, Vicksburg, Miss. . . . . 22  
 The Onondaga County (N. Y.) Cemetery Association. . . . . 113  
 \*The Parks of Duluth, Minn. . . . . 118  
 The Proposed Park System of Troy, N. Y. . . . . 48  
 The Short Planting Season of the North. . . . . 43  
 \*The Smith Mausoleum, Charleston, S. C. . . . . 120  
 \*The Stag's Horn Fern. . . . . 45  
 Trees. . . . . 44, 157  
 \*Trees in Tower Grove Park, St. Louis, Mo. . . . . 166  
 \*Tropical House, Fairmount Park, Philadelphia. . . . . 131  
 Trustees of Cemetery Personally Liable on Note. . . . . 102
- Useful Memorials. . . . . 37
- Validity of Testamentary Wishes as to Burial. . . . . 49  
 Valuation of Land for Park Purposes. . . . . 139  
 Velvety Lawns. . . . . 210  
 Village Parks. . . . . 192  
 Vines and Grasses. . . . . 53
- \*Walnut Hills Cemetery, Brookline, Mass. . . . . 150  
 \*Washington Park, Albany, N. Y. . . . . 182  
 \*Washington Park, Chicago. . . . . 2  
 \*Yuccas and Grasses. . . . . 7
- \*Illustrated.



# PARK AND CEMETERY.

FORMERLY THE MODERN CEMETERY.

A Monthly Journal Devoted to Parks and Cemeteries.

R. J. HAIGHT, Publisher,  
334 Dearborn Street, CHICAGO.

Subscription \$1.00 a Year in Advance. Foreign Subscription \$1.25.

VOL. V. CHICAGO, MARCH, 1895. NO. 1.

## CONTENTS.

EDITORIAL .....	1
*WASHINGTON PARK, CHICAGO.....	2
*CEMETERY OF SPRING GROVE, CINCINNATI, O .....	4
*YUCCAS AND GRASSES.....	7
PROPOSED PARK SYSTEM FOR ESSEX COUNTY, N. J....	8
*THE GROTTO, FOREST HILLS CEMETERY, JAMAICA PLAINS, MASS.....	9
*CEMETERY GREENHOUSES—WHEN, WHERE, AND HOW TO BUILD. III .....	11
ROLLING COUNTRY.....	13
NELUMBIUMS .....	14
*FROZEN FOUNTAIN.....	14
PARK NOTES.....	15
CEMETERY NOTES.....	16
FAMILY RIGHTS IN THE BURIAL PLACES OF THE DEAD	17
CORRESPONDENCE.....	17
CEMETERY REPORTS.....	18
PUBLISHER'S DEPARTMENT.....	

\*Illustrated.

SINCE the decision has been made known to our subscribers to enlarge the scope of this paper under the title of PARK AND CEMETERY, quite a number of them have expressed, in very gratifying terms, their approval of the change. The superintendents of our leading cemeteries, generally, have for a long time recognized the fact that the requirements for the cemetery, apart from the burial of the dead, are very largely those of the park. The work of *The Modern Cemetery* has been that of the dissemination of progressive ideas in cemetery management, the outcome of which should result in the transforming the gloomy and forbidding graveyards into burial parks, for such our cemeteries should be.

MORE often than otherwise the rural cemetery is practically the village park, the obligation upon the community, therefore, to make this as attractive as possible should be apparent. It is gratifying to note the awakening to this necessity, and the growing activity in the work of clearing up and beautifying the village burying ground.

AN excellent suggestion is conveyed by the National Sculpture Society, in their announcement of its forthcoming Second Annual Exhibition to be held in the American Fine Arts Society's Building, New York City, May 7, to May

23, next. It says: "In connection with the display of sculpture will be an exhibition of Landscape Gardening, after designs by Nathan F. Barrett, landscape engineer, and Thomas Hastings, architect. The purpose of this exhibition is to show the possibilities of combining sculpture with flowers and plants in both natural and formal gardening and interior decoration." It is well said that "the country is being dotted over with memorial buildings and statues on pedestals, in most of which structures a lamentable lack of taste and of knowledge is felt to exist." And most of our so-called statuary consists of soldiers' monuments, very largely stereotyped in form and style, while sculpture as one of the highest forms of Art, finds little recognition or encouragement at the hands of the American people to-day.

IN this connection, the time is very opportune to impress upon the attention of Park Commissioners and officials, the desirability of including in the requisites pertaining to Park improvement, ideal sculpture, to be appropriately and intelligently disposed in park schemes, looking to the surroundings to emphasize the value of the work of Art, and the work of Art to improve the surroundings.

Ideal statuary is not necessarily nude, classical figures; it is quite possible to treat most of the statues of our noted citizens and leaders in an ideal way, especially those whose services have been rendered to the community in the cause of higher development. The park systems of many of our large cities surprise foreign visitors, but the absence of anything to show the art development of the people is equally astonishing.

There can be no question as to the advantages to be gained by adding to our parks beautiful statuary. It is a sure indication of the intelligence of our citizenship, will raise the ethical values of our parks beyond calculation, will arouse the dormant art instincts of our people, and moreover, will be an important factor in raising the standard of American Art.

THE conflict of the professions appears to have been mildly waged again in the prosecution of the Harlem Speedway scheme in New York. Without going into the details of this particular instance, more than to note that the question of precedence seems to be between the landscape architect or designer, and the City Engineer, it is to be noticed that where the press has discussed the matter, it has been on the same old preju-

## PARK AND CEMETERY.

diced lines, each advocating the side its columns represents, which, while being, so to speak, "patriotic," does not offer anything towards solving the difficulty, but rather encourages inter-professional prejudice. There should be no conflict whatever between the landscape designer, engineer, architect, or whatever may be the distinguishing factor of his professional title, and the civil engineer. The civil engineer is, as a rule, not a landscape designer, and the landscape designer is not a civil engineer, and yet in our large parks, particularly, both are necessary in their development. To cut the material for a long discussion short, they should work in harmony, and if particular men on either side will not do so, others can be found with wisdom enough to see that the fruition of a good plan lies in such harmony. In the ordinary run of things you might with equal chance of success, ask the engineer to devise an artistic park scheme as the landscape designer to construct a good road with its possible necessities of drainage, culverts and bridges, or to overcome difficulties presented by the material to be dealt with.

The engineers and architects' professions years ago went through this stage of experience, resulting in to-day that the prominent firms combine the professions, and each have learned to respect the other to mutual advantage. The making of a good road is much more than the laying it out either on paper or on the ground, or the leading engineers of the country would have no need of the amount of literature constantly produced on the subject, to keep them up to date. On the other hand the construction of roads, bridges and other works, in a park is not landscape designing, which requires artistic development to a large degree, and the lights of this profession illustrate the fact that natural gifts have materially aided them in the particular line of practical art they have chosen. Solid digging and delving into nature's secrets, and the mathematics to solve them, are the fundamental requirements of the engineer, in contrast with the natural artistic sense of the landscape architect, broadened by the studies necessary to enable him to reproduce nature's most desirable effects, and the ability to introduce and carry them out. The art instinct is a prime requisite in the furnishing of a competent and successful landscape designer.

With the exception of a very few phenomenal men, the landscape designer cannot fill the engineer's place, nor the engineer the landscape designer's, professional bias to the contrary, notwithstanding. Each has an important duty in large undertakings, whether of cemeteries or parks, and in harmony they must work for the best results.

### Washington Park, Chicago.

An important section of Chicago's magnificent series of parks is Washington Park, and when the transformation of the world renowned Midway Plaisance is complete, a work which is being vigorously pushed, it will be hard to point to a grander or more beautiful example of municipal improvements in any part of the world.

It was less than thirty years ago that the first bill was presented to the Illinois legislature for the establishing of a park in this vicinity, and in 1869 the law was passed, at which time all three divisions of the city were agitating the park question. The act of 1869 created Boards of Park Commissioners, and special assessments were levied to defray cost of acquiring property.

The South Park system comprises the World's Fair site and contains more territory than all the other park systems of the city combined. The original valuation of the land as designated by the act was \$1,865,750, but it was afterwards found that a far larger amount of money would be required.

Mr. Fred Law Olmsted, the well known landscape engineer, of the firm of Olmsted & Vaux of New York, whose opinions were valuable in the preliminary investigations, was engaged to furnish plans and specifications and the work was commenced in good earnest in 1869. The great calamity of 1871 checked progress for a year, but in 1872 it was resumed and Mr. H. W. S. Cleveland was appointed landscape gardener. The original designs of Mr. Olmsted were deemed too costly to carry out in their entirety, but the main features were retained, in such a way as to produce the best effects by a careful arrangement of trees and shrubs, and the construction of lakes and waterways in the most economical manner possible, and avoiding the use of statuary, stonework and expensive buildings. The commissioners early displayed a wise conception of the meaning and intention of public parks,—that of affording pleasant and healthful recreation to all classes and conditions of people; and they appreciated the importance of all improvements being made with the specific view of giving the greatest facilities for their use, by the class of citizens compelled to spend most of their lives in the city, and to whom groves and stretches of lawn are of far more value than expensive driveways which are for the most part only available to people of means.

The entire amount of land now embraced within the limits of the South Parks and Boulevards is 1,306.75 acres, of which Washington Park contains 371 acres, all improved, and nearly seven miles of drives.

Dr. G. H. Rauch, many years secretary of the Illinois State Board of Health, in an able paper on



the influence of parks on the community, before the Academy of Sciences, at the time the subject was first agitated, very exhaustively discussed all the features touching upon the question, detailing the physical conditions affecting Chicago and warmly advocating a generous policy in this direction. Among other things he said: "We need parks to induce out-door exercise, and for the pleasant influences connected with them, which are so beneficial to our over-worked business men, to dyspeptics, to those affected with nervous diseases, and, particularly to the consumptive. We need parks for our school children, as we have no places to which they can resort for out-of-door play, and where they can obtain healthful recreation, with the exception of the limited grounds surrounding the school-houses."

"The moral influence of the parks is decided, man is brought in contact with na-

ticular attention has been paid to landscape art, in the views and effects which form a charming panorama of beautiful vistas and arrangements of plants and shrubs at every turn one makes. Here before one stretches an expanse of well kept lawn, broken here and there to give character by clumps of choice bushes and bounded by groves of various descriptions of trees according to the well matured design. Another path will gracefully turn among a dense collection of handsome shrubs and trees, which af-



THE LAKE, WASHINGTON PARK.



AQUATIC GARDEN, WASHINGTON PARK, CHICAGO.

ford many a cool and secluded nook for refreshing rest and reflection. Magnificent trees, evidences of culture and care on every hand, yet nothing set and formal: nature copied and encouraged to assert her delightful characteristics for the enjoyment and education of man, are the governing features of Washington Park.

The work of improvement is carried out on the line of advanced ideas in landscape work, both in the matters of general

ture—is taken away from the artificial conditions in which he lives in cities; and such associations exercise a vast influence for good."

All this is absolutely true and is being realized the more appreciably as the intelligence of the people expands; and that the people are enjoying the privileges they have created is measurably displayed by the constantly increasing numbers who betake themselves to the parks for recreation.

In the development of the improvement of the territory comprised in Washington Park, more par-

results, and the grouping and massing of shrubs and trees to produce fine effects both in form and color; so that through the seasons nature may contribute by her infinite variety of expression, to the higher pleasures of man's existence.

At the western entrance climbing plants have been freely used to show what picturesqueness may be obtained, either in the graceful covering of tall tree stumps or the training over paths in arch-like naturalness. Towards the eastern side is the flower garden section, near which are the extensive green



houses, palm house, stables and out-buildings. Emblems, figures and floral efforts in unique designs form yearly an exhibition of what can be done by expert gardeners, and have proved a growing attraction.

One of our illustrations gives a characteristic view about the lake, and charming vistas open up in every direction, and on a bright day the shadow effects are splendid. Reverse the view given and almost the exactness of the picture itself is seen in the shadows.

The aquatic garden is a comparatively new feature in our northern parks, and has proved, as might have been expected, a very popular attraction. During the season the rich and gorgeous water flowers are profuse in their display and nothing has been spared to render the success of this addition to the park in any way doubtful.

The illustration of a section of the lily pond shows the *Victoria Regia* in excellent condition and the picture moreover, displays a delightful arrangement of path and shrubery in proximity to the pond.

There are no monuments in Washington Park, and while this is in a certain sense to be regretted, the commissioners are to be commended for their decision in regard to such as have been offered. By the will of the late John Crerar, a very large sum of money was left for a monument to Abraham Lincoln, and now that all legal difficulties appear to be overcome, it may be expected that this year will witness action of the Trustees toward carrying out the project, and Washington Park would be a splendid site. The ball set rolling, the next monument should be Washington, on an equally grand scale as that for which the large sum left by Mr. Crerar for the Lincoln monument should provide.

To show the requirements for the work of improvement which is still progressing, it may be stated that last year, over 14,500 shrubs, trees and evergreens were obtained and set out.

The park is lighted by electricity on moonless nights up to 11 p. m.

#### **Cemetery of Spring Grove, Cincinnati.**

The Cemetery of Spring Grove obtained its charter Jan. 21st., 1845. The first meeting to elect directors was held Feb. 8th., 1845. The area at that time was 166 acres of undulating surface covered with forest scenery and numerous springs, which suggested the name "Cemetery of Spring Grove." It now has an area of 600 acres, of which 360 are improved by being laid off into 86 sections, averaging in size  $3\frac{1}{2}$  acres each, with 15 miles of road surface averaging in width 21 ft., making a total area of road surface of 38 acres. The Mc Ad-

amized form of road making is adopted. In the past twelve years nearly all the roads have been covered with from 4 to 8 inches of broken stone,



INTERIOR VIEW, ENTRANCE TO CEMETERY OF SPRING GROVE.

with drains laid along the sides having proper inlets. Many of the old boulder gutters have been replaced by a flat paving stone set on edge on a bed of six inches of sand; the stone being 6 inches wide makes a total depth of gutter material of 12 inches. The gutter is usually made 30 inches wide and conforms to the shape of the road, from center to the sides, consequently the gutter does not interfere with any of the room of the road, and is quite as useful in carrying off water as the old style deep dish gutter, which was always unsightly and could not be used to drive over. The grades vary from level to 16 per cent, from lowest to highest there is a difference of 160 ft. elevation. Vitrified pipe is used for sewers, laid about 4 ft. below the surface.

In laying out new grounds a space of not less than 3 ft. between the lots and avenues is reserved, in which to lay the drain or water pipes, instead of in the road, as was formerly done; the reason for this is that the space is always in sod which makes it easy to dig up if necessary and does not obstruct the use of the roads; it is always in position to accommodate the inlets for surface water, and there is no danger of crushing from heavy loads of stone.

The nature of the soil is largely clay,—about one hundred acres of sand, and gravel. The lots vary in size from one hundred to ten thousand square ft., the average size being 350 ft. There are about ten thousand single interments, the price for which is 15 dollars each which includes opening of the grave. The restrictions on single graves are now the same as all others namely; nothing is permitted to be planted thereon other than myrtle, which is done by the cemetery. A charge of six dollars is made, including watering and care for one year, three dollars per year after the first year;



grave marks on single graves must not exceed 4 inches in height, and are placed at head of grave.

There are some old fences not yet removed, but neither copings, or fences have been permitted to be erected for the past 25 years; the lawn plan is enforced, not permitting any visible path between lots; the general surface of lot and path are of same grade and continuous in lawn surface. Some land is reserved for ornamental planting, and the aim is not to plant trees on lots, but in some of the paths, and corners which are reserved when laying out for that purpose.

The rules require that lot owners before ordering a monument shall submit the design of same to the Superintendent and directors. This rule is unfortunately transgressed by many, the monument being ordered and ready to be set before the cemetery officials have directions to build the founda-

a cost of not quite 3cts per thousand gallons.

There are no green houses, and the plantings of perishable plants is discouraged in the belief, that ornamental trees and shrubbery properly distributed over the grounds, also hardy herbaceous plants are preferable; they are more in harmony with the natural landscape, produce more of a variety, and a longer season of ornamentation than the summer plants, which are secured at greater cost for the short season from June 1st to the middle of September whereas the others are perennial.

The receiving tomb is an inexpensive structure, costing about 7,000 dollars, with capacity for holding about 250 bodies. The number of interments to date are 57,000.

The original plan of the grounds was made by John Notman, the designer of Laurel Hill Cemetery, Philadelphia, Pa., and it was carried out by



VIEW IN CEMETERY OF SPRING GROVE, CINCINNATI.

tion; it is too late then to make suggestions, which would probably have kept the cemetery from having a very unsightly piece of stone, called a monument, placed in some conspicuous location to remain there forever a monument offensive to good taste, and art, and a mark of condemnation to its owner and the designer. Efforts are constantly in effect to correct this by strictly enforcing the rule bearing on the subject.

The water system consists of driven wells, and collecting water gallery; the water is gathered into a large cistern of 40 thousand gallons from which a million gallon pump forces it through an 8 inch iron pipe to a  $2\frac{1}{4}$  million gallon reservoir, one mile distant, and at an elevation of 160 ft. From the main pipe, 3 inch branches are taken through the grounds as service pipes to domestic and fire hydrants, fountains, and other supplies to the lakes, also the toilet rooms and other buildings. For all purposes about 80 million gallons are consumed per year, at

Howard Daniels the first Superintendent. His successor was Dennis Delaney. The larger portion of the grounds has since been surveyed with trigonometrical precision by the late Thos. Earnshaw and Sons, the late Henry Earnshaw and the present Jos. Earnshaw of the firm of Earnshaw & Punshon. The present plan of improvement was adopted by the board of directors in 1855 at the suggestion of the late A. Strauch, the superintendent and landscape gardener. It is the application of the plan described by the late John C. Loudon and other eminent authors, by which the capacities of the grounds have been so far developed, and with such success as to render its continuation of the highest importance to the interest of the place.

The number of men employed averages 70 the year round; among these are 5 night watchmen, 2 gate-keepers, one engineer, one black-smith, one stone cutter, Superintendent of interments, Superintendent of construction and cleaning force; 1



# PARK AND CEMETERY.





stable boss, 2 gardeners, one clerk, one in charge of all buildings, 8 teamsters, and 6 grave diggers. The rest of the force is employed in the improvement and cleaning of the grounds.

The receipts of the cemetery from all sources is about \$90,000 per year. There is a surplus of \$290,000. The affairs of the cemetery are managed by a board of nine directors, men of the highest standing and character, who give their services without any compensation whatever. They are constantly mindful of their trust, and guard the interests of the lot owners with fidelity and good judgment. The annual meeting of the lot owners is held the first Monday in October to receive the reports of the Secretary and Superintendent and elect directors, three of whose term expires each year. The old members are always re-elected.

Cincinnati, O.

Wm. Salway.

#### Yuccas and Grasses.

Yuccas are prominent among those hardy plants that have enough character to fill a distinct place in landscape work. In fact they serve well where nothing else will serve. One thinks of no other genus with varieties that are at once reliably hardy, and tropical in effect. It is an unusual combination. Some of the finer ornamental grasses do, in a sense, come under this description, but they are quite different in style and have a place of their own without infringing the rights of the Yuccas.

Indeed the similarities and dissimilarities of the hardy representatives of these two genera fit them not only for use in similar situations, as in isolated clumps, forming the outposts as it were, of shrubby borders, or singly in certain locations; but for being used together. They would be excellent in combination for plantings of a semi-formal character, such as are especially appropriate in connection with architecture or architectural effects. A good example of their use in this way was shown at the World's Fair in the plantings on the lower terrace



PART OF TERRACE PLANTING, WORLD'S FAIR GROUNDS.



YUCCA AUGUSTIFOLIA AT MISSOURI BOTANICAL GARDEN, ST. LOUIS.

facing the canal, between the Manufactures and Electricity Buildings, and which were practically repeated on each side of the broad flights of steps leading from the lower terrace, at the north and south of the grand basin, to the entrances of the Manufactures and Agricultural Buildings. These plantings were not formed of the plants in question, but the general effect produced by those that were used could be almost exactly reproduced by the others.

In such positions Yuccas and hardy grasses like the Eulalias, Erianthus Ravenna and Elimus glaucus might replace the tropical plants and tender grasses (like Pampas) that formed those delightful examples, thus making permanent plantings instead of ephemeral ornaments of a season, and this too, without losing the spirit of the original scheme. There is variety yet unity in such a combination, and withal a style that is in keeping with architectural lines and masses.

It will be recalled that the Fair plantings referred to had clipped lawns in the fore-ground, the retaining wall of the upper terrace, surmounted by a heavy railing, as an immediate background, while a little beyond rose the wall of a building. One end of each somewhat long and comparatively narrow planting was close in the angle formed by the retaining wall and descending flight of steps, and in this corner the tallest growing specimens were placed, and from them the growths sloped downwards, but not too regularly, for the line was broken, and diversified by well chosen species, until each group ended with a plant of somewhat low growth that blended its lower leaves with the grass of the lawn. The front edge of each planting was also of such plants as are clothed to the ground, so that without any sharply defined lines, there were



no ragged edges, and each group looked finished and complete.

Yuccas, when used as the skirmish line of shrubbery plantations or borders look especially well when seen against evergreens, and the good effect is emphasized when the plants flower because the dark background affords fine relief for the stately candelabra like streaks of creamy, drooping blossoms. This arrangement has the added advantage of furnishing a decorative effect that continues throughout the year.

But perhaps Yuccas look best, because most at home, in conjunction with rocks. At all events there is no doubt about the pleasing result of such designs, and the plants like the sandy soil that seems to belong in stony ground, although they like it both deep and rich. This is particularly true of *Y. filamentosa*, the best known and most commonly seen variety. In fact so high an authority as Mr. Falconer advises digging and enriching the soil for this sort to a depth of "three or more feet," and his experience is that with such deeply worked, dry, rich soil they do best when left undisturbed to form large multicrowned plants. As I have seen them they are certainly far more decorative when grown in this way than when grown to one crown only.

While *Y. filamentosa* is highly desirable, it should not wholly crowd out *Y. angustifolia* that is equally hardy, equally as attractive and seems to be rather more adaptable to various soils and situations. On the arid, almost desert lands of eastern Colorado and western Kansas, and particularly over the vast plains of Gypsum in the region of the Cimarron river, it grows in countless thousands, piling itself into almost impregnable interlaced masses.

Yet, despite the character of its natural environment, the clump shown in our engraving, though brought from just such a site, has grown for a number of years (more than ten) in its present location, and it is about the most unsuitable spot, one would think, that could be selected, since it is inclined to dampness. In fact in spring the soil is decidedly spongy, a condition that it retains as long as it conscientiously can under the blazing sun of a St. Louis summer. Nevertheless it has formed itself into a symmetrical, yet picturesque group some five feet in diameter (it may be more,) is constantly increasing in size, never fails to blossom every year, and is at all times a chaste and interesting clump that shows up well against the rich green of the Hemlock hedge beyond it.

FANNY COPLEY SEAVEY.

The refining influence of parks in every city has not been sufficiently appreciated.—*Du Chaillu*.

#### Proposed Park System for Essex County, N. J.

One of the most comprehensive projects that has ever, probably, been considered in the way of a county park system, is that recently reported upon by the Commission appointed by the act of the legislature of New Jersey of May 1894, to consider the question as related to Essex County of that State.

The Commission consisted of the following: Cyrus Peck, President; F. W. Kelsey, Vice President; and S. J. Meeker, Treasurer. Alonzo Church was elected Secretary by the board.

The report which has been recently issued, cannot fail to redound to the credit of the board, for the wisdom and energy displayed in the fulfillment of the task allotted to them. The first and main difficulties in the study of a scheme of such magnitude involving high professional knowledge and broad experience, was very properly met by securing advice from men whose lives have been spent in such work. In the pursuance of this policy, Messrs. Frederick Law Olmsted and J. C. Olmsted of Olmsted, Olmsted and Eliot; John Bogart, N. F. Barrett, Ehrenberg & Webster, and Gray & Blaisdell prepared and submitted reports, after a careful study of the situation. These reports embodied a series of different schemes from which to be able to devise a system combining the excellencies of all.

Suggestions were also invited by circular letter from County officials, boards, improvement societies and others whose opinions might be of value. It may surely be expected that the results of such a policy reinforced by a careful study of the situation and conditions which the gathered information called for, will inure to the public welfare. It has moreover, proved a most economical policy both in time and money, for less than half the money appropriated was consumed. The following extracts from the report afford food for reflection.

"We are unanimous and emphatic in the belief that parks are not only desirable but necessary for the well being of the people.

"It is an unquestioned fact that public parks and playgrounds are one of the most important factors in the real practical development of cities. Communion with nature is always elevating and the good done to the overworked denizens of crowded city streets in wandering through green pastures and beside still waters is incalculable. The mind is purified, the eye is educated, the heart delighted and the tired body refreshed. Innocent pleasure and healthful exercise are combined in a fine and bracing air, and it can be truly said that a park is the heart free beating, the lungs free breathing of a great city."



Some statistics relating to the pecuniary benefits to surrounding property are given. In New York city in 1856, the assessed value of the three wards adjoining Central Park was \$20,429,565; in 1873 it was \$236,081,515. The natural average increase of three other wards in the city, when all the wards had been averaged, was \$53,000,000, making the earning capacity of the park, \$183,081,515.

In Brooklyn, in 1864, when Prospect Park was acquired, the three neighboring wards were assessed at \$19,949,395, and at the end of three years the valuation had risen 38 per cent. Interesting statistics of other cities show like gains due to the influence of the park.

Governor Werts of New Jersey, in a late message to the legislature said: "The setting aside of tracts of land for public parks, as places of public recreation, rest and enjoyment, has come to be regarded as a necessity rather than a mere convenience. They conduce to the public health, promote the general happiness and encourage citizenship. As public investments they are remunerative and profitable. Experience has proved that the increased valuations in the vicinity of a well regulated park will soon more than pay the cost of the original investment."

The commission advises the purchase of land for the entire project as the first step to avoid the certainty of increased cost in the future from speculative energy. It is proposed to lay out four parks in the four quarters of the county, and by parkways and boulevards blend them all into a system that the people in every section may be benefited. These connecting links would utilize existing roads as far as possible, and include smaller parks in thickly settled districts.

The amount required for the work is estimated at \$2,500,000, which seems to be a moderate amount considering that some 4000 to 4500 acres of land is to be improved.

Essex County contains such towns as Newark and Orange, and its population comprises a large number of New York's business people,—a population which will undoubtedly appreciate the advantages and pleasures which such a park development will afford.

The bill has passed both houses of the legislature unanimously, with the important amendment that the question must be submitted to the vote of the people of the county. The Park Commission has earned the commendation of all parties for its faithful and disinterested labors, and for the exemplary wisdom and economy which has characterized its methods.

The measure should be accepted by the people, the heaviest taxpayers being its warmest supporters.

#### The Grotto, Forest Hills Cemetery, Jamaica Plain, Mass.

The Grotto, illustrated herewith, is located a short distance from the main entrance to the grounds, at the junction of Willow, White Oak and Rock Maple Avenues, and covers an area of about 10,000 square feet. It is laid out with winding paths in as natural and picturesque manner as possible and no large boulders or any of the natural ledge has been disturbed; but in order to completely carry out the plan many large boulders were brought from other parts. An arch and bridge have been constructed to give easy access from one place to another and a close inspection of the view shows, at the rustic bridge end near the cluster of oak trees, a platform arranged for a look-out, from which a fine view of the large lake and the surrounding grounds can be obtained. On the other side of the picture a summer house is located, which is a delightful resting place for visitors, and there are several small founrains and waterfalls scattered about the grotto, which add very much to its attractiveness, and give on a hot day a refreshing and cooling effect.

The particular object of this article is to show that where like facilities can be had, no park or cemetery need be without of attractions in a floral display, nor dependent for this result upon the products of the greenhouse. It is true in this illustration a few Agaves are seen, but they will not be used any more, it being intended to fill the entire grotto with the best hardy and other native plants that can be obtained, and a few shrubs where they can be suitably located, thus placing it virtually where it will take care of itself. This phrase is not used to convey the idea that it needs no care at all, but that the growing hardy plants will keep it a source of delight without annual replenishing.

It would be impossible in limited space to describe in detail the arrangement, but perhaps a good help would be the following short detailed list of what is growing there. There is no place in Forest Hills more sought than the Grotto, and perhaps none that given more pleasure to the numerous visitors.

FERNS:—*Adiantum pedatum*, maiden hair fern. *Aspidium marginale*, evergreen wood fern, good for rocky places. *Dicksonia punctilobula*, does well in sunlight or shade and is commonly known as Gossamer fern. *Onoclea sensibilis*, sensitive fern. *Ophioglossum vulgatum*, (Adder's Tongue Fern) planted in shady moist nooks. *Osmunda regalis*, (Flowering Fern) one of the prettiest. *Osmunda Claytoniana*, a tall growing variety clothed with loose wool when unfolding its fronds in the spring, soon becoming perfectly smooth. *Pellaea atropurpurea*; an expert in fern culture says





THE GROTTO, FOREST HILLS CEMETERY, JAMAICA PLAIN, MASS.

that it flourishes best in a dry rocky place, hidden from the sun, and seems to delight when planted in the crevices of a wall where there is good drainage. *Phlegopteris polypodioides*, (Beech Fern). Rock garden or any garden soil in shade, easily cultivated. *Polypodium vulgare*, one of the best evergreen species for rock work, generally found on half shaded rocks. *Scolopendrium vulgare*, (Harts Tongue) fine for rock work in moist shady places.

PLANTS:—*Phlox reptans*, flowers in June, a low plant, with large rose purple flowers, very floriferous, makes a fine show in front of the rockery. *Phlox subulata*, (Ground or Moss Pink,) flowers pink, purple or rose color with a darker center and like the *P. reptans* make a fine show in front of the rockery. *Saponaria scymoides*, (Rock soapwort,) a beautiful dwarf perennial; completely covered with rosy pink flowers all summer, and made the finest show in front of the rockery. *Heuchera sanguinea*, tufts of cordate leaves, stems eight to twelve inches, loose heads of vivid lovely crimson flowers. *Campanula persicifolia alba*, flowers in June and July, a large clump makes a fine show, sending up spikes three feet high. *Funkia grandiflora*, July to September, a fine pure white, large flowered, and exceedingly fragrant species, with handsome broad light green foliage. The variegated form does well

in half shady places, and has beautiful foliage. *Hemerocallis flava*, (Day Lily,) golden yellow, very fragrant. *Lotus Corniculatus*, flower all summer, is a beautiful yellow carpet of gold, and is a fine rock plant where the sun can shed its rays. *Lychnis alpina*, flowers, rose-colored, in clusters, makes a fine show, is a dwarf variety. *Lychnis chalcadonica*, a tall growing variety, flowers orange scarlet, July. *Mertensia Virginiica*, (Virginia Cowslip.) This plant grows one to two feet high, bearing a rich panicle of rich purple or sometimes white flowers. *Monarda didyma*, (Oswego Tea) two to three feet high, with bright red flowers forming clumps, (very fine). *Dodecatheon Meadia*, (Shooting Star.) A very pretty smooth perennial, with rose colored or sometimes white flowers. *Trillium grandiflorum*, probably the prettiest of the genus, and more generally cultivated. It grows eight to fifteen inches high, bearing a large white flower, often two to two and a half inches wide, turning to lilac color with age. *Trillium erectum*, has broader, rhomboid leaves with a dark purple flower. *Cypripedium acaule*, May and June, (Lady Slipper Moccasin flower,) flowers are rose purple in color. The plant sends up two broadish green leaves from the base, and from between them comes a stalk about a foot high, bearing a single large showy flower. *Cypri-*



*pedium spectabile*, the largest species of this genus and by far the most beautiful of them all, the plant is about two feet high when well grown, leafy throughout, bearing one to several large pink, purple and white flowers. *Spiraea filipendula flore pleno*, numerous corymbs of double white flowers and pretty fern like foliage, one of the best hardy perennials we have. *Veronica rupestris*, creeping habit, flowers showy blue in dense spikes, in May and June is a solid carpet of rich blue, it is an excellent plant.

SHRUBS:—Clumps of the beautiful *Berberis Thunbergii*. A species from Japan of small foliage, changing to a beautiful red in autumn; the habit is quite dwarf.

VINES:—*Euonymus radicans*, green. *Euonymus radicans variegata*. These two varieties are used in abundance, as they will cling to stone, just as the ivy does, is an evergreen, and do not winter-kill, we consider them very valuable.

The undergrowth all through the Grotto is native violets and Lily of the Valley which are very handsome early in the season.

The trees are very largely Red Oaks of which there are some noble specimens, and a few other species and varieties.

Very much more might be added to this description of the Grotto, but enough has been said to satisfy the reader, that this is not only an attractive but very interesting spot, and if a diversion is permissible the fact might be mentioned that while there is a large greenhouse plant, it is the intention of the Trustees to use in the prominent ornamental parts of the grounds all hardy plants, shrubs and evergreens, using the greenhouse to supply the orders of proprietors and in such ornamental places only where the surroundings will admit. It would be an injustice to the gardener, Mr. Westwood, were a mention not made of his interest in all the work pertaining to his department; and the fine appearance of the Grotto the last two seasons is due to the interest, care and skill he has bestowed upon it.

Boston, Mass.

John G. Barker.

**Cemetery Greenhouses.—When, Where and How to Build. III.**

As plants must be taken into the houses in the fall in order to propagate and grow the stock for spring sales, it follows that the houses should be complete and ready for use by September 1st. The durability of the houses depends largely upon the care which is given to every detail of the construction, and when time is short and the work must be hurried, it is likely to be slighted. The building should, then, if possible, be commenced early in the spring. The plans should all be work-

ed out during the winter, and every detail complete and all material on the ground when the work is begun.

The houses should not be so near the entrance as to be unsightly, and yet not too far away from the office. A level piece of ground, or one with a gentle slope to the south should be selected. For cut flower houses which are run east and west, a decided slope to the south is an advantage, but for the plant houses, with which we are at present concerned, as they run north and south, a steep slope is objectionable. If the ground is dry throughout the year, or so situated that a drain can be laid, allowing the boiler to be set in a pit considerably lower than the houses, so much the better. It is well to have the houses sheltered from west and north winds, but there should be nothing to shade them on the south, east and west. If a special house is built for propagating, it will be rather an advantage, than otherwise, to have it shaded, but

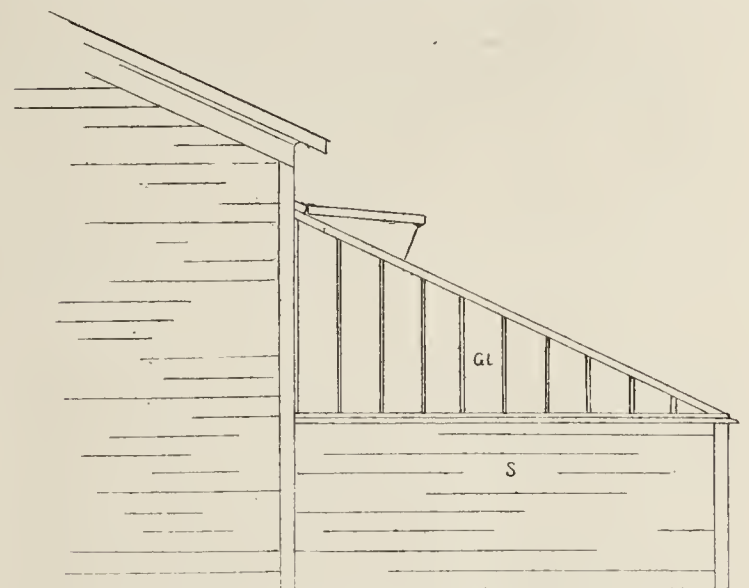


FIG. 1.—END VIEW OF LEAN-TO HOUSE. V, VENTILATOR. GL, GLASS. S, SIDING.

the growing houses should have the full sun all day. All depressions in the site selected should be filled, all elevations cut away so as to leave the general surface smooth and either level or with a general slope of, preferably, not over 1 foot in 100 feet to the south. The grading should if possible be done in the fall, so that the filled places may become solid and firm by spring. The surrounding ground should be so graded or ditched as to carry all surface water away from the houses.

The first thing to be considered in developing the plans is the form or style of the houses. There are two kinds of plant houses in common use; the lean to, of which an end view is shown in Fig. 1; and the span roof, or even span house, as shown in Fig. 2. A third style, the three-quarter span, is sometimes used for this purpose, but it has no ad-

vantages over the span roof for plant growing. It is the style in general use for growing cut flowers.

The Lean-to is a shed shaped structure erected against the south side of a building. Sometimes it is built against the east or west side, though this is not advisable, and when used for propagating it is generally attached to the north side. It cannot well exceed in length the width of the building to which it is attached, and can not be of great width as the roof will then become too flat and will be leaky and snow will lodge on it badly. It is the simplest and cheapest form of greenhouse, and, if it can be built large enough to supply all requirements, is to be recommended. Other houses can not be readily added to it however, and, if there is a prospect of more room being needed in the future, the span roof house should be built.

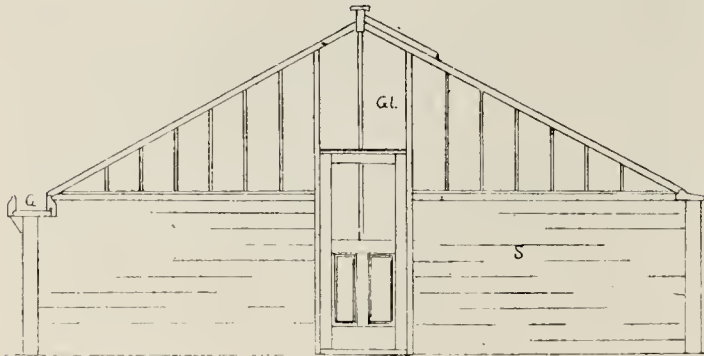


FIG. 2.—END VIEW OF A SPAN ROOF HOUSE. V. VENTILATOR. GL. GLASS. S. SIDING. G. GUTTER.

The construction of a lean-to house is nearly the same as that of one-half of a span roof and, therefore need not be described in detail.

The even span house is the one in common use, and for the great majority of cases it is the best and cheapest style, everything considered.

By building a gutter on one side, as shown at G. in Fig. 2, another house can be added at any time, the gutter supporting the roof of the second house, so that only one additional side wall is needed. A number of such houses may be built side by side with gutters between. This is called the "Ridge and Furrow" system, and is, perhaps the most compact and cheapest way of building a block of houses.

Even span houses are built of all widths from 9 or 10 feet to 25 feet wide or even wider. The narrower houses are built with a bench at each side on which the plants are set, and a walk in the middle, lengthways. The wider houses are generally built with a narrow bench at each side, two walks and a wide middle bench as shown in Fig. 4.

This may be considered in general, the best way to build. It certainly is the cheapest, as one can get as much bench room in a 21 foot house, with only two side walls to build, as in two 11½ foot houses with three side walls.

The side benches are generally 3½ or 4 feet wide. The former is best, as it is difficult to set the plants at the back of a 4 foot bench.

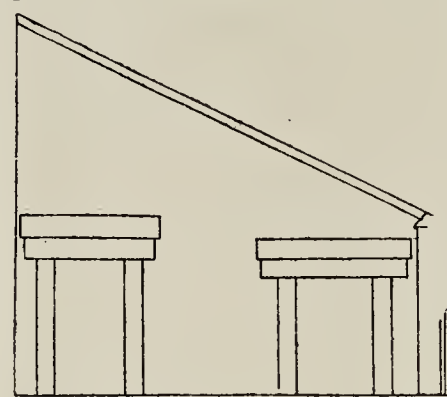


FIG. 3.—LEAN-TO HOUSE. CROSS SECTION SHOWING ARRANGEMENT OF BENCHES.

The walks are built 1½ to 2½ feet in width, but it is not best to make them less than 2 feet, and where visitor sare to be admitted they should be 2½ feet. The center bench is reached from each walk and may be double the width of the side benches,

although 6½ feet is more convenient. The side benches should be about one inch further away from the wall than the plate, (the piece on which the ends of the sash bars rest when there is no gutter,) and edge of the gutter are. This will allow the water which condenses on the glass inside the house or leaks through, to run down to the plate and gutter and drop behind the benches, instead of upon the plants.

We then have two 3½ foot benches, two 2½ foot walks, one 6½ foot bench and an extra inch on each side, making in all 18 feet 8 inches which is the distance across inside the house from plate to gutter. The distance from inside to inside of sheathing will be about 16 to 18 inches more, varying according to the width of gutter and the varying dimensions of plate and gutter patterns of the different manufacturers.

Having settled upon the width of the houses, the next question is the length. A long house is proportionately cheaper than a short one. They

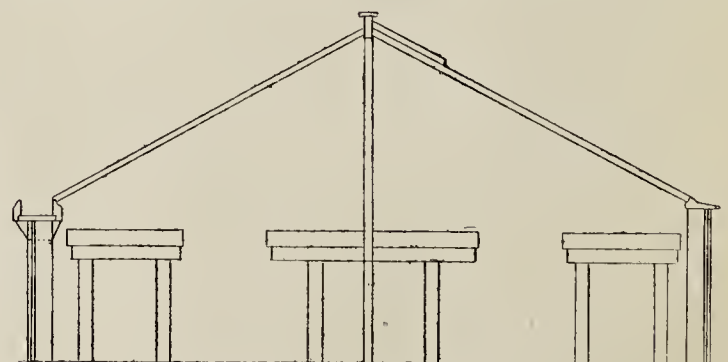


FIG. 4.—CROSS SECTION OF AN EVEN SPAN HOUSE, SHOWING ARRANGEMENT OF BENCHES.

are built of any length up to 150 feet, or even larger. A house of excessive length requires more labor to operate it in proportion, than the same amount of space in shorter houses. It is also more



difficult to maintain an equal temperature in all parts of a long house.

It is generally considered that 100 feet is the best length for plant houses. Two houses one of which can be kept at a higher temperature than the other are very desirable and for this reason it is better to build two 50 foot houses than one 100 foot house and the expense is not so very much greater as we have but 150 feet of wall instead of 200. They will also be found cheaper to heat. Unless absolutely necessary it is not wise to build them less than 50 feet as the saving in cost is not proportionate to the loss of space.

At the north end of the houses and attached to them, a shed must be built, generally extending the width of the houses and 10 to 12 feet wide. In this will be placed the heating apparatus, the pots, soil and tools, and the work of potting will be done here. A part of the shed can be partitioned off as an entrance room and the dirt dust and disagreeable features kept from the view of the visitors.

A small lean to propagating house attached to the north side of the shed will be found a great convenience, though not essential. For two houses 50 to 100 feet long, 6 or 8 feet by 15 or 20 feet will be sufficiently large for the propagating house.

Chicago.

*Willis N. Rudd.*

*(To be continued.)*

#### **Rolling Country.**

All surfaces of land are either up the hill or down the furrow in a rolling country, unless indeed, as is sometimes the case, flat lands intervene. When such flat surfaces occur in the valleys they are commonly wet, and should either be drained or flooded, the latter expedient is often advisable.

Rolling country embraces a great portion of the earth's surface, and is greatly diversified in character, not as much so as highland, for its contours are more rounded, but it is rich or sterile, wooded or grassy, well watered or desert, and sometimes even rocky.

The rich woodlands and grass hills are mostly chosen for residence, and are most amenable to improvement, but even desert lands may be made to yield to the gardener with water.

Gently rolling hill sites are among the finest of the landscape gardener, who delights in such scenes, can be called upon to treat. Not infrequently they open upon extensive panoramas of mountain, plain, river and lake. In themselves they are often capable of the highest degree of culture and embellishment. They are commonly full of inhabitants, and it is rather an object to secure seclusion, than to invite such animation as would be desirable among mountains.

They present all the desiderata of garden, park and farm. Their culture will therefore be higher than the mountain lands, and they will lack only in grandeur, solemnity, and perhaps picturesqueness. When the site is chosen for beauty, it will consist largely of the concave, and command as great a variety as possible. The human eye is naturally filled with delight when ranging over a hollow. It can take in all its expressions, all its sides, and a third more downwards than upwards from the horizontal line of sight. Frequently the vision may range over the upper surface of a woodland—a particularly pleasing sensation to those who have never before seen such a surface.

In purchasing such sites it will often be found that the lumberman and the farmer have been there, and their operations have mostly been devoid of taste. They have been severely utilitarian may be. Often they have been severely destructive, both of beauty and fertility. If the land has been cleared of every vestige of useful wood, the task of the gardener is simple and agreeable, for he can then perhaps find room to plant a full selection of all the series of trees, shrubs, and plants which are suitable to the climate. Generally however, sites are selected with more or less of woodland. The timber is but rarely useful, the trees are individually crowded, drawn and bare, as individuals they are failures, as groups they are frequently insipid and monotonous. They will often require the nicest, and most discriminating treatment, they will need removing, thinning, and embellishing. Sometimes a site which is perfect in every other way, will be spoiled by a group of scrub woodland blocking the outlet to its choicest scenery. In such an event there should be no hesitancy; but a dynamite cartridge laid beneath each tree. Trees grow more rapidly than is often realized. Many of those also which have reputations for slowness are very fast growers. The English oak for instance will grow nearly as fast again here as in England, and if any piece of mixed woodland be examined, it will be found that the American oaks in their beautiful variety are among the loftiest and fastest of hard woods, and they even overtake the maples in time. Opposite where I write all obtainable trees were planted forty years ago. Such as remain are now deemed old.

It is one of the pleasant signs of the times that farms are being bought by people of culture and education—not so much for their profit, as for the superior beauty and salubrity of their sites. Children thrive upon the fresh milk and country air, and instruction and never ending interest may be provided in the plantations, while they contribute to the embellishment and unification of the property.



Mistakes are of common occurrence, and none more common than calling in the architect before the gardener. I have in mind a very recent experience. A gentleman purchased a superb site—perfect in every desirable feature, and his architect has done his utmost to spoil it by idiotic choice of building sites. The house is set upon the steep brink of a declivity, with ample room in front—but in the rear there is not room for a road or a drying ground, or a group of sheltering trees, much as all these are needed. Thirty feet or forty feet further from the steep bank would have given all of these conveniences, without a particle of sacrifice. As a rear approach was made impossible, and the stables were called for, the only available site proved to be one in front of the house, and situated on the approach before reaching it. It is really too bad to see such blunders possible, but I suppose they must continue while Americans persist in employing paper men.

It is impossible for a man to properly arrange the conveniences of a complete country residence site unless he has lived and moved through their varying phases, and nursery men, architects, and city men of business have but rarely had such experience.

Trenton, N. J.

*James MacPherson.*

#### Nelumbiums.

Mr. W. Tricker, of Clifton, N. J., in a communication to *Garden and Forest* says of this class of water Lilies: The Nelumbiums have no rivals among aquatic plants for stateliness, and they can be used not only in the large lakes and water-basins of public and private parks, but they have a refined character which makes them appropriate even for small water-gardens. They are so perfectly hardy that it is difficult to understand the frequent complaints that they are difficult to grow and establish. One cause of failure may be that they are planted too early. Planting should be delayed until warmer weather and genial conditions set in, so that the tubers or plants will make active growth at once. When tubers are received from a distance they may have been subjected to a warm temperature in shipment, and therefore, the chill of a plunge in cold water may check their vital energies. Where the tubers have made young rootlets it is much safer to plant them in shallow boxes and keep them protected either in a cool greenhouse, pit or frame, until it is safe to place them in permanent quarters. By all means avoid the check to growth which always means weakness, if not actual death, to the plants.

Another good plan is to place such roots in large pots or pans and keep them growing until

warm weather, when the plants can be turned out with a good ball of soil and roots, and carefully deposited where they are to bloom. Where there are no tanks for the reception of large pots, tubs can be used. Another method is to start seeds. Of all seeds none germinate more readily than those of Nelumbiums, provided the hard shell is filed through at the base of the seed so that water can penetrate. The plumule escapes first, sometimes two or three days before a rootlet is visible, and always from the base; therefore, by filing at this particular spot much assistance is given to the young seedlings. In a temperature of seventy-five degrees the seed will germinate in about six days, sometimes less.

The seeds may be placed singly in small pots, or may be started in water and potted afterward; in either case the young plants must be grown and established in large pots or pans before planting permanently. Nelumbiums will not flower the first year as seedlings, but will, in most cases, do so the second or the following year. Apart from the flowers, Nelumbiums are highly ornamental plants and worthy of cultivation for foliage alone."

The editor adds: "Two seeds were placed in a small bottle of water and set on a desk in his office, and they germinated within a week."



Mr. S. W. Rubee, Secretary, Riverside Cemetery Association, Marshalltown, Ia., sends a photograph of their fountain as it appeared this winter. The above illustration is reproduced from the photo.



## ◁ PARK NOTES. ▷

John and David Snyder, of Springfield, Ohio, have given to that city land worth \$250,000 for a park.

\* \* \*

Troy, New York, is seriously agitating the park question in connection with some proposed annexation, and a large amount of money will be necessarily involved in the project if the commissioners are enabled to carry it out.

\* \* \*

The receipts for the Chicago park systems for the past year, from assessments and other sources, have been, including balance from previous year: for the South park system, \$1,126,914.-74. For Lincoln park, \$421,340.74. For West park system, \$314,754.10.

\* \* \*

The Board of Park Commissioners of New York city do not regard it as expedient to make further provision for additional small parks other than the parks advocated by the Tenement House Commission, to be located in the thickly populated tenement section on the east side of the city.

\* \* \*

A tribute to the man, who is frequently quoted as the "Father of the Park System" of Pittsburg, Pa., Mr. E. M. Bigelow, is about to be erected in Schenley Park in that city. It is a bronze statue, surmounting a Quincy granite pedestal and will cost some \$12,000, raised by public subscription.

\* \* \*

The establishment of small parks in the crowded parts of our great cities is receiving much attention. Now that the value of such breathing places is acknowledged, vindication of the neglected philanthropic ideas of years ago is pronounced, in the fact of the immense cost of the property required now to carry out the plans.

\* \* \*

The cast has been made for the heroic bronze statue that the city of Akron, O., is about to erect in commemoration of the late Simon Perkins who gave to Akron land of great value for park purposes. The statue is to be placed in one of the parks that he presented to the city. This is a movement in the right direction, emulation of which would greatly benefit most of the cities of the country.

\* \* \*

A bill about to be presented to the New York legislature contemplates that the state shall acquire the control of the springs at Saratoga, and include that property in a State park. A fear is developing that continued boring by the proprietors in the region of the mineral water reservoirs will sooner or later destroy the springs. The amount required for preliminary purchases, etc., is put at \$1,500,000.

\* \* \*

The Board of Commissioners of the West Park system of Chicago have received the estimates of George W. Dorr for the completion of that system. The figures for the completion of Humboldt, Garfield and Douglas parks, Humboldt Boulevard to Lincoln park, Southwest boulevard to the boulevards of the South park system, Douglas boulevard and the Ogden Avenue viaduct are \$1,892,000. A resolution was introduced asking the legislature to appropriate \$900,000 to complete the system.

\* \* \*

Another park system is being agitated for Chicago. It is proposed to create such a system along the banks of the Des-Plaines river, which passes through many of Chicago's suburbs, and is withal, quite a pretty stream. Plans have been prepared

and meetings have been held to consider the matter. The scheme contemplates parks and boulevards each side of the river for a distance of about eight miles, between Turner Park and Riverside. The river is well wooded throughout this distance.

\* \* \*

Director Bigelow of the Pittsburg parks has received an order for a 10 in. Columbiad gun, a donation from Congress. He will find a place for it in one of the parks. He is also working upon securing an equestrian statue of General Grant, for park purposes. The proposed "maze" is also to be constructed in Schenley park this summer. The children always delight in such attractions, and the few important ones that exist in the the world are very popular and excite much interest.

\* \* \*

Lovers of nature all over the country, who have heard the progress of destruction of the well known palisades of the Hudson River, will be gratified to learn that the New Jersey legislature has passed what is known as the Palisade Protection bill. It provides that hereafter the Riparian commissioners shall not lease any land adjacent or in front of the Palisades, unless there shall be inserted protective provisions. Public sentiment demanded the passage of the bill, and it was carried by a vote of 45 to 6.

\* \* \*

The committee appointed by the mayor of Brooklyn to secure sites for new parks has reported. The committee secured the help of the landscape architect Mr. F. L. Olmsted. The committee recommends that new breathing places for the people be acquired at Cypress Hills, Bay Ridge, Fort Hamilton, Bensonhurst, Canarsie and eight other places in Brooklyn, some 1000 acres. The total cost of acquiring these properties is estimated at some \$2,600,000. New York has 5,136 acres of park lands, in the ratio of 362 inhabitants to each acre of park land. Brooklyn, or rather Kings county, has 2,762 acres of park lands, or about 2,000 acres less relatively than New York. The weather is delaying further investigation.

\* \* \*

Considerable park extension is contemplated for Boston, if the necessary powers can be secured. Jamaica park, one of the most recent acquisitions of the Boston parks, and already one of the most popular, is rapidly assuming a park-like appearance, but much work of considerable magnitude will be necessary before its contemplated perfection is assured. Jamaica pond demands considerable attention and offers a grand opportunity for important work. In front of the refectory near the pond a handsome terrace will be constructed this season, in the center of which the beautiful bronze fountain, modeled by Miss Anne Whitney will be erected. Jamaica park will enjoy the distinction of being both a winter and a summer park. An appropriation of \$1,000,000 is being asked as necessary for present contemplated additions etc.

\* \* \*

The value of small parks in crowded localities in our great cities is being appreciated more and more as the race becomes enlightened. Philadelphia's Starr Garden Park, a small breathing spot in the heart of the slum district, is to be enlarged. It is a memorial more enduring than any material to the beneficence of Charles Starr and the labors of his associates of the college settlement established there, who have endeavored to mitigate the conditions of this locality, and the mayor of Philadelphia is to be congratulated on the ordinance passed and signed to carry out the good work. An extension to Fairmount Park, Philadelphia, is also being discussed. It is proposed to construct a broad park-like boulevard to extend the park practically to almost the center of the city. The cost is estimated at \$2,500,000.



---

## CEMETERY NOTES.

---

A receiving vault is to be constructed in Oak Ridge Cemetery, Altoona, Pa.

\* \* \*

Bills to create State Boards of Embalming are being rapidly introduced to the legislatures now the ball has been set rolling. Undertaker's license bills are also being pushed in many states.

\* \* \*

Land for a new cemetery for Waverly, N. Y., to be called "Glenwood," has been purchased. The site is claimed to be a most desirable as well as a beautiful one, and contains some 65 acres. Work of improvement will be commenced at once and pushed vigorously.

\* \* \*

A bill is pending in the California legislature prohibiting burials within city limits of towns of 100,000 or over. It is to take effect January 1st, 1900, but will only trouble San Francisco. All its prominent cemeteries are within the bounds and these corporations may be expected to offer vigorous opposition.

\* \* \*

The National Casket Company has put Aluminum to a new use. The company has put two styles of casket, constructed principally of this metal, on the market, entirely different in design to what we are accustomed to see. The characteristics of the metal are claimed to be greatly in its favor for the purpose.

\* \* \*

A prisoner was arraigned for assault recently in a Philadelphia police court and after giving his name was asked where he resided. In response he replied, "my home is in Mount Peace Cemetery." "Why, that's a place where dead people live," suggested the magistrate. "That don't make any difference," replied the prisoner, "I live there and I am a pretty lively dead man."

\* \* \*

The Board of Riverside Cemetery Association, Molinc, Ill. gave instructions to provide a set of blanks for the perpetual care of lots under an ordinance passed August 5th 1889, by which any lot owner paying \$20 for the first 400 square feet, and at the same rate beyond that amount, will have the obligation of the city to forever take care of the lot. There is now quite a demand for lots upon this basis. Mr. George Oldefest was chosen Superintendent.

\* \* \*

A bill introduced into the Pennsylvania legislature provides that where a cemetery is located partly within a city and partly within one or more boroughs or townships of the Commonwealth, such cemetery shall be subject to the rules of the Board of Health or ordinances of the city within which part of the cemetery is located, and shall not be subject to obey the ordinance of any borough or township, if it has complied with the ordinances of the city. This is an effort to settle some of the cemetery difficulties which Philadelphia has had to wrestle with.

\* \* \*

Forest Hill Cemetery, Kansas City, Mo., is rapidly assuming the beauties accompanying the modern ideas. Of its 320 acres some 80 had over \$40,000 expended upon improvements, and another 80 is laid out for improvement and work is going on. A nursery has been established in which nearly 100 varieties of trees are being grown for transplanting as required. It has a lovely lake centrally located, and over seven and a half miles of road graded and three and a half miles of driveways macadamized. A receiving vault, costing \$11,000, has just been completed, modeled after that of Woodlawn. There are already several fine private vaults and monuments, and the cemetery

management is adopting a liberal policy to assure attractive results after the most approved modern practice.

\* \* \*

Plans and specifications have been drawn and accepted for a family mausoleum to be erected in Springdale Cemetery, Clinton, Iowa, by Mr. W. J. Young. It will occupy a commanding position on a beautiful knoll in the center of the cemetery, and will be built of Barre granite. It will be 20' 4" long and 15' 6" wide at the base and 16' 6" high. The capstone to cover the tomb will be a single block of granite, weighing over 20 tons. The interior will contain 20 crypts—10 on each side—and two additional crypts will be built in the floor, making receptacles for 22 bodies in all. The floor will be of Italian marble and the broad hallway will be amply lighted by a window in the rear end. Particular attention has been paid to the ventilation. The vestibule with its polished granite pillars will be guarded by an outer gate of bronze and the tomb proper with a swinging door of solid granite. This door may be left open, thus admitting of perfect ventilation. J. E. Harrison & Son, of Adrian, Mich., are the designers and builders. The foundation will be of native material. Work will begin as soon as the weather will permit. Cost, about \$15,000.

\* \* \*

Attention is drawn to the following from Mr. Geo. T. Angell, President of the American Humane Society.

On this January 22 we received a letter from the editor of the *New York World* in regard to our *American Humane Education Society* petitioning the legislatures of the various states this winter to pass an act *authorizing the inspection of the dead before burial*.

We have at various times written and published a good deal, on this subject, and would respectfully ask the editors of *the about 20,000* American publications, including all north of Mexico, to whom we send a marked copy of this article, to kindly bring this important subject, through editorials and otherwise *before the legislatures of their respective states*.

Our own father came near being buried alive, having been pronounced dead by his physician, and we shall be happy to render every assistance in our power to aid in obtaining laws throughout our entire country requiring *competent and careful inspection of the supposed dead before burial*. GEO. T. ANGELL.

\* \* \*

One of the most interesting of the old historic burying grounds in Connecticut is that at the back of the Centre Church at Hartford, largely on account of its singular table monuments. The remains of Thomas Hooker, "The Light of the Western Churches," who led the Connecticut colonists from Concord in Massachusetts through the wilderness to Hartford in 1639, and died there ten years afterward, rest here. Several of the monuments and gravestones bear the date of 1660 and thereafter until 1700, says a writer in the *New York Times*. Near the entrance to the grounds is a broken column erected to the memory of Jeremiah Wadsworth, the Connecticut adviser of General Washington during the Revolutionary war. One of the most notable of the table monuments was erected to the memory of John Ledyard, the ancestor of Colonel William Ledyard, who was killed by an English officer after surrendering his sword, Sept. 7, 1781, at Fort Ledyard, in New London Harbor. The chivalric light dragoon, Thomas Y. Seymour, who figured in Trumbull's paintings of Burgoyne's Surrender and The African Traveler, John Ledyard, are buried in these ancient grounds that have been consecrated by the dust of Hooker and the founders of the colony. Several governors are also buried in the inclosure. The town of Hartford is the owner of the historic spot, and the care bestowed upon it does not aggregate \$100 a year.



**Family Rights in the Burial Places of the Dead.**

A decision of more than usual interest to our readers has been rendered by the supreme court of Iowa in the case of *Thompson v. Deeds*.

Philip Deeds was first married in 1837, and lived with his wife until her death, in 1862. At her death, and by the consent of all parties, she was interred in a lot now claimed to be owned by their daughter, and which is in the cemetery at Lyons, Iowa. Her remains still rest in said place. He was married again in 1864, and lived with his second wife until his death, in 1890, when, with the assent of both, the daughter and widow, his remains were interred beside those of his first wife, as he knew who held the title to this lot, and more than once, during his life time, expressed a wish, that when he died he might be interred therein, beside the remains of his first wife.

It further appears that the widow's own means, bought a monument at an expense of \$1,200, which she proposed having erected upon said lot, in memory of her deceased husband and others buried therein. She also bought stone coping for the lot, at an expense of some \$500. But for some reason his daughter objected to the actions of her stepmother, whereupon it was claimed that the widow threatened to remove the remains of her husband to another lot, unless their differences were adjusted. The daughter then brought this action to have her title to the lot quieted, and asking the issuance of an injunction to restrain the widow from removing the remains of her father from the lot.

Now the supreme court holds that the fact that the daughter had the legal title to the lot wherein rested the remains of her dead father was not of controlling importance, in determining as to the right of the widow to remove his remains. If the title was held by a stranger, or if he were buried in a lot under the mistaken belief that he or some member of his family owned it, there might be reason for removing the remains. As it was, the owner of the lot being his daughter, there was no reason for disturbing his remains. A proper appreciation of the duty we owe to the dead, due regard for the feelings of the survivors, and public health and welfare, all require that the bodies of the dead should not be exhumed, except under circumstances of extreme urgency.

Having assented to her father being buried in her lot, the court further holds that the daughter ought not to be heard to say that his widow should not erect thereon, to his memory, a suitable monument. Deceased wanted to be buried there; the daughter wanted him thus gratified, and he was buried in her lot; and, under such circumstances, the widow must be held to have the unquestioned

right to properly improve and adorn his last resting place. It would be a doctrine abhorrent to our sense of what is right and just to say that, after deceased had been buried in his daughter's lot, she alone should be permitted to testify to her affection for him by the erection of a monument to his memory, and by otherwise adorning and embellishing his last resting place. This daughter and this widow should remember that their differences should be obliterated in the common desire and effort to suitably testify to their respect for one who was, as to one of them, a father, and, as to the other, a husband. What matters it that the law has said that after burial of a husband the wife shall have no control over his remains; that his next of kin have the exclusive right of disposition thereof? This court has said that for some purpose at least, the widow is to be treated as next of kin. It always has been the duty of courts to see to it that the expressed wish of one, as to his final resting place, shall, so far as it is possible, be carried out.

A decree, it is further held, should have been entered for the daughter enjoining the removal of the body of her father, but authorizing the widow to erect upon the lot in which rested his remains, a monument to his memory, with proper inscriptions. Under the peculiar circumstances of this case, the widow's right in this respect should be properly guarded, as to the size and location of the monument, having in mind the daughter's right to occupy and use the rest of the lot. But no inscription should be permitted to be placed upon the monument in any way referring to the daughter or her first husband whose remains lay in said lot. On the other hand, the court holds that the widow should not be permitted to erect a coping around the lot. To do so, it says, would be a virtual act of appropriation of the whole lot, which, under the circumstances, would be manifestly improper. Finally, it is said that the decree should be broad enough to permit both parties, as well as any of the kin of the deceased, to, at their pleasure, decorate the grave of the deceased with flowers, and, in so doing, not to interfere with each other.

---

## Correspondence.

---

### Removing Name Plate from Caskets,

*Editor Park and Cemetery:*

SIR:—In several parts of the Dominion of Canada there is a very common practice of removing the engraved name plate from the coffin previous to interment. I would like the opinion of yourself or some of your many readers as to the best way to discourage the practice, or if there are any cemeteries that prohibit their removal. I think it is a great mistake, and a very



poor way to bury our dead,—consigning the bodies to the earth after depriving them of the only instrument they possess by which they might be recognized in years to come, or in case a removal is necessary.

I should suggest that if it is necessary to have a removable plate at all, let the funeral director furnish a duplicate, and thus avoid robbing the dead of the possibility of identity should circumstances require it

J. P. C.

## CEMETERY REPORTS.

At the annual meeting of the proprietors of Harmony Grove Cemetery, Salem, Mass., the secretary's report showed:

Sales of lots the past year amounted to 3,458 square feet, as against 2,565 in 1893, making a total since the grounds were opened in 1840 of 550,165 feet. The interments for the year numbered 155, one less than in 1893, and making a total of 8,332. There was one removal in 1893. There were 31 brick or slate graves made last year, three less than in 1893; and 108 headstones and monuments set, two less than in the previous year. Fifteen fences were removed, while there were 22 in 1893. There were 16 endowments, one less than in 1893, making 225 in all.

The treasurer reported receipts last year \$24,070.12, which with previous balance of \$354.32 made \$24,424.44. The expenditures were \$23,451.12. The endowment fund commenced in 1860, reached \$11,000 in 1881, and now amounts to \$55,000.

\* \* \*

At the annual meeting of the Mount Pleasant Cemetery Company, Newark, N. J., the treasurer's report was rendered and showed:

Balance on hand February 1, 1894, \$5,988.68; and other receipts, \$20,336.29. Among the items were: lots sold, \$6,100; care of endowed lots, \$107.30; receiving vault, \$5.00. Among the expenditures were: labor, \$4,208.48; salaries, \$3,383.33; general expenses, \$1,270.54. The amount invested for the care of lots is \$6,799.80.

## Publisher's Department.

Park Commissioners and Cemetery trustees are requested to send us copies of their reports.

Photographs and descriptive sketches of interesting features in parks and cemeteries are solicited from our readers.

The widespread interest manifested in the development of our parks and cemeteries makes timely the discussion of systems of management, plans for improving and the various other topics pertinent to the question. Will our readers give us the benefit of their experience?

Reports received: 22nd Annual report of the Fairmount Art Association and Souvenir of the Works of Art contributed by the association to Fairmount Park, Philadelphia.—Annual Reports of the South Park, West Park and Lincoln Park Commissioners, Chicago.—Essex County, N. J., Department of Parks. Report of the Board of Commissioners appointed under the Act of legislature approved May 8, 1894.—Descriptive pamphlet with several half tone illustrations of Forest Hill Cemetery, Kansas City, Mo. Also containing Rules and Regulations, and

other information.—Transactions of the Massachusetts Horticultural Society for 1894.

Trade Catalogues Received: Wm. Trieker & Co., Clifton, N. J. Water lilies, choice aquatics, grasses, etc.—Ellwanger & Barry, Mt. Hope Nurseries, Rochester, N. Y. Supplementary catalogue of trees, shrubs, roses, etc.—Phoenix Nursery Co., Bloomington, Ill.—Shady Hill Nursery Co., Boston, Mass. Trees, shrubs, vines, etc.—The O. S. Kelly Co. A beautifully illustrated portfolio of engravings showing the Springfield road rollers making roads in the principal cities of the United States.—Jesse B. Kimes, Philadelphia. Slate burial vaults, markers, posts, etc.—Gardens and the Landscape Engineer. A beautifully illustrated brochure in the interest of artistic grounds and their harmonious treatment, by Gray & Blaisdell, Boston.

One of the most artistic and beautiful sets of photogravure reproductions from photographs we have ever seen is that of a series of views of the aquatic garden of Mr. S. C. Nash, of Clifton, N. J. Each of the twenty pictures is a gem in itself, and is evidence of the deep interest Mr. Nash takes in his water garden. Apart

from the beauty of the pictures is the important feature of what delightful results can be obtained even in our northern latitudes from the cultivation of this department of horticulture, which develops a keener interest from the novelty of the work. The originals of the pictures were superb photographs taken by Mr. Nash himself, and he informs us that it having been suggested to him that lovers of aquatics would be benefited greatly by possessing the pictures, he had an extra number run off, sets of which he will gladly furnish at cost, viz: \$3 per set, postage paid. Mr. Nash is justly proud of his water garden, and the pictures were intended solely for his own gratification.

At the annual meeting of the lot-owners of the Fairmount Cemetery Association, Newark, N. J., the treasurer reported:

The financial statement showed a cash balance on March 1, 1894, of \$5,202.14; receipts from sale of lots and graves, \$44,638.49; for caring for graves, \$1,025; total, \$50,865.63; expenses, salaries, etc., \$34,503.39, leaving a cash balance of \$16,362.04, on March 1, 1895. During the year the sale of 89 lots realized \$29,946, and 618 single graves, \$6,239. \$8,493.49 was received for opening graves and incidentals.

## Association of American Cemetery Superintendents.

O. C. SIMONDS, "Graceland," Chicago, President.

G. W. CREESY, "Harmony Grove," Salem, Mass., Vice-President.

F. EURICH, Woodlawn, Toledo, O., Secretary and Treasurer

The Ninth Annual Convention will be held at Richmond, Va., September 18, 19, and 20, 1895. A number of interesting papers have been promised.

## C. HENNECKE Company,



Milwaukee Wis.,

Manufacturers of

Iron Vases, Wire

and

Wrought Iron . . .

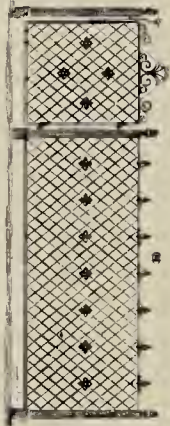
. . . Fences, etc.

Lowest Prices

Guaranteed.

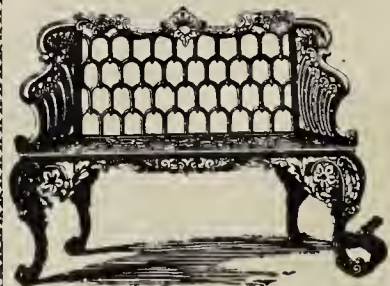
Write for Illustrated

. . . Catalogue . . .



from the beauty of the pictures is the important feature of what delightful results can be obtained even in our northern latitudes from the cultivation of this department of horticulture, which develops a keener interest from the novelty of the work. The originals of the pictures were superb photographs taken by Mr. Nash himself, and he informs us that it having been suggested to him that lovers of aquatics would be benefited greatly by possessing the pictures, he had an extra number run off, sets of which he will gladly furnish at cost, viz: \$3 per set, postage paid. Mr. Nash is justly proud of his water garden, and the pictures were intended solely for his own gratification.

## Flower Vases,



IRON SETTEE. Catalogue Free.

E. T. BARNUM, DETROIT, MICH.

Iron and Wire Chairs,  
Settees, Grave Guards,  
Fences, Vault Gates, etc.



# PARK AND CEMETERY.

FORMERLY THE MODERN CEMETERY.

A Monthly Journal Devoted to Parks and Cemeteries.

R. J. HAIGHT, Publisher,  
334 Dearborn Street, CHICAGO.

Subscription \$1.00 a Year in Advance. Foreign Subscription \$1.25.

VOL. V. CHICAGO, APRIL, 1895. No. 2.

## CONTENTS.

EDITORIAL .....	19
*JACKSON PARK, CHICAGO.....	20
*THE NATIONAL CEMETERY, VICKSBURG, MISS .....	22
HOW TO MAKE AND CARE FOR A LAWN.....	24
PUBLIC PARKS AND PLEASURE GROUNDS.....	25
*OAK GROVE CEMETERY, BATH, ME.....	26
PLANTING ON GRAVES.....	28
*GREENHOUSES—HOW TO BUILD. IV.....	29
*RIVERSIDE CEMETERY, NORRISTOWN, PA .....	31
REFORM IN THE USE OF BEDDING PLANTS.....	31
*SALISBURY TOWER, INSTITUTE PARK, WORCESTER, MASS .....	32
PARK NOTES.....	33
CEMETERY NOTES.....	34
CORRESPONDENCE.....	35
CEMETERY REPORTS.....	35
PUBLISHER'S DEPARTMENT.....	36

\*Illustrated.

THE Michigan Chickamauga Monument Commission has selected designs, and awarded contracts, for the eleven monuments to commemorate the part Michigan troops took in that campaign, and for which the state appropriated \$20,000. This commission very wisely aimed to obtain designs, which, while being appropriate for the purpose and location, should be a departure from the stereotyped form of cemetery memorials. Of the several hundred designs submitted, but very few were appropriate for this very reason. This great National Park will be made or marred by the actions of the several State Commissions in the selection of memorials this Spring, and if the discrimination exercised by the Michigan Commission should be coincident with that of other like bodies, these memorials will not be the least of the many attractive features of the Park.

IT is gratifying to note the increasing interest displayed in the direction of taking up the question of the "grave-yard" or "burial ground," among our smaller communities. It has often been asserted in these columns, that such interest once aroused, it would very soon attract all the funds and help necessary to make the village cemetery a source of pride, rather than what it generally is, a

disgrace to the locality. With the reviving of the proper and natural spirit, there must always exist feelings of reverence and of hallowed memories clustering about such resting places, and with due diligence and application, sentiment may be crystallized into effort, with the result that improvement organizations may be easily got into working order with the Cemetery as the main object. Such an object affords a varied and attractive field for labor, and yields abundant results. An attractive, well cared for cemetery gives a rating to the Community; it affords opportunities for the display of taste and knowledge in the acquisition and care of flowers, shrubs and trees. It creates opportunities for social amenities, and tends also to the cultivation of the higher attributes of mankind. With the efficient help of the local press, whose assistance should be assiduously cultivated, an impetus may be given to the work, and the rural cemetery be made a delightful burial park and the pride of the community.

THE Park Commissioners of our larger parks have no sinecure job on their hands, and the office is no empty honor. On the other hand the appointees must be qualified for the work, and should be selected with due regard to such qualifications. Business routine and knowledge can be far more easily acquired than taste, which is in the nature of a gift and, though it may be more or less cultivated, is innate. In the care and development of our Park systems, the exercise of taste is always in order, and should be exercised to exclude all unsightliness and inappropriateness in the appurtenances connected with modern improvements as they present themselves for adoption. The cry comes from the East that one of the most beautiful parks is being marred by unsightly electric light poles and the network of wires, and that the choicest views are degraded by waterworks and electric light buildings. The current in the first place should be carried underground, and the buildings should be erected where they interfere the least with the landscape effects. Such disfigurements are inexcusable in park practice.

WHETHER statuary is an appropriate addition to the adornment of a public park, is a question that admits of doubt, if the dictum of a certain New York daily be admitted as conclusive. In the circular distributed by the National Sculpture Society announcing the forthcoming



exhibition, and in which certain landscape effects in connection with sculpture are to be introduced, some pointed suggestions were made relative to this important consideration, which were quoted in a previous issue of this journal. The main question seems to be one that only the intelligence of a community can answer, and it is the growth of that intelligence that decrees, first: whether there shall be a park at all; next, and progressively, whether the park shall be improved according to the best known experience, and then whether the highest efforts of man shall find expression therein, in order that the park may afford recreation to the intellectual as well to the material forces of man's nature. It is but in the primitive ideas of our civilization that a public park is only a playground. The development from this as a beginning has been quite regular, a few trees for shade, a patch of shrubbery here and there for effect, a little pond for diversity, until the growth of a higher sentiment has decreed extensions and improvements of all these, and then the necessity has asserted itself for educated and systematic treatment of these pleasure spots, and the park in its degree of beauty and value to the community becomes assured. Science and art go hand in hand in the laying out and perfecting of a park. A profound knowledge of the character and values of plants and trees must be combined with no small artistic sense to produce a harmonious arrangement, gratifying and exhilarating to the senses. Such a progressive development leads up to the wise use of statuary in well ordered park systems. Not set as in an exhibition gallery. Not distributed or placed to mar or detract from the specific beauty of natural effects; but so ordered as to add to such attractiveness the spirit that exhales from a beautiful work of art, so that the one complements the other, and of sufficient frequency to refresh and not weary, to afford such a combination for intellectual and physical recreation as may tend to a truly ideal enjoyment.

#### **Jackson Park, Chicago.**

Jackson Park is not to be shorn of all the glory which the World's Fair bestowed upon it. A beautiful park before that time, a place of world-wide repute while the scene of the grandest artistic and architectural display ever devised, it is now in process of rehabilitation to become one of the finest parks in the world.

The South Park Commissioners have begun work in earnest; the debris of the great exposition is rapidly disappearing and a plan and suggestions prepared by the well known landscape architect, Mr. F. L. Olmsted, have been accepted.

The accompanying plan gives the main points of the scheme, which is broad and comprehensive

in its general aspect, and while retaining many of the features characteristic of the landscape design of the World's Fair, is dominated by the sole idea of a beautiful park, with ample provisions for all the recreative facilities which the modern park should include for refined and enlightened recreation and exercise.

The opening paragraphs of Mr. Olmsted's report give the text for the treatment. He says: "The finest thing about the park is unquestionably the view of Lake Michigan which is obtained from the shore. To enable the public to enjoy this shore and this view, the plan proposes a shore road which, beginning at the northern end of the park, will pass southward between the museum and the beach, cross the north inlet by a bridge and terminate only when the south inlet is reached. That the south inlet should be kept open to boats entering from the lake seems more desirable than that the shore road should continue any further southward. Between the two inlets the road will follow a gentle curve about three-fourths of a mile in length. The terminal circle at the end of this long sweep of shore road will also be the land end of a pier, at which steamers from Chicago may land passengers as they did during the World's Fair. Here may ultimately be placed the principal restaurant of the park, called on the plan the Casino. Its windows will command fine views of the lake, the curving shore, and the sheltered anchorage of the south haven."

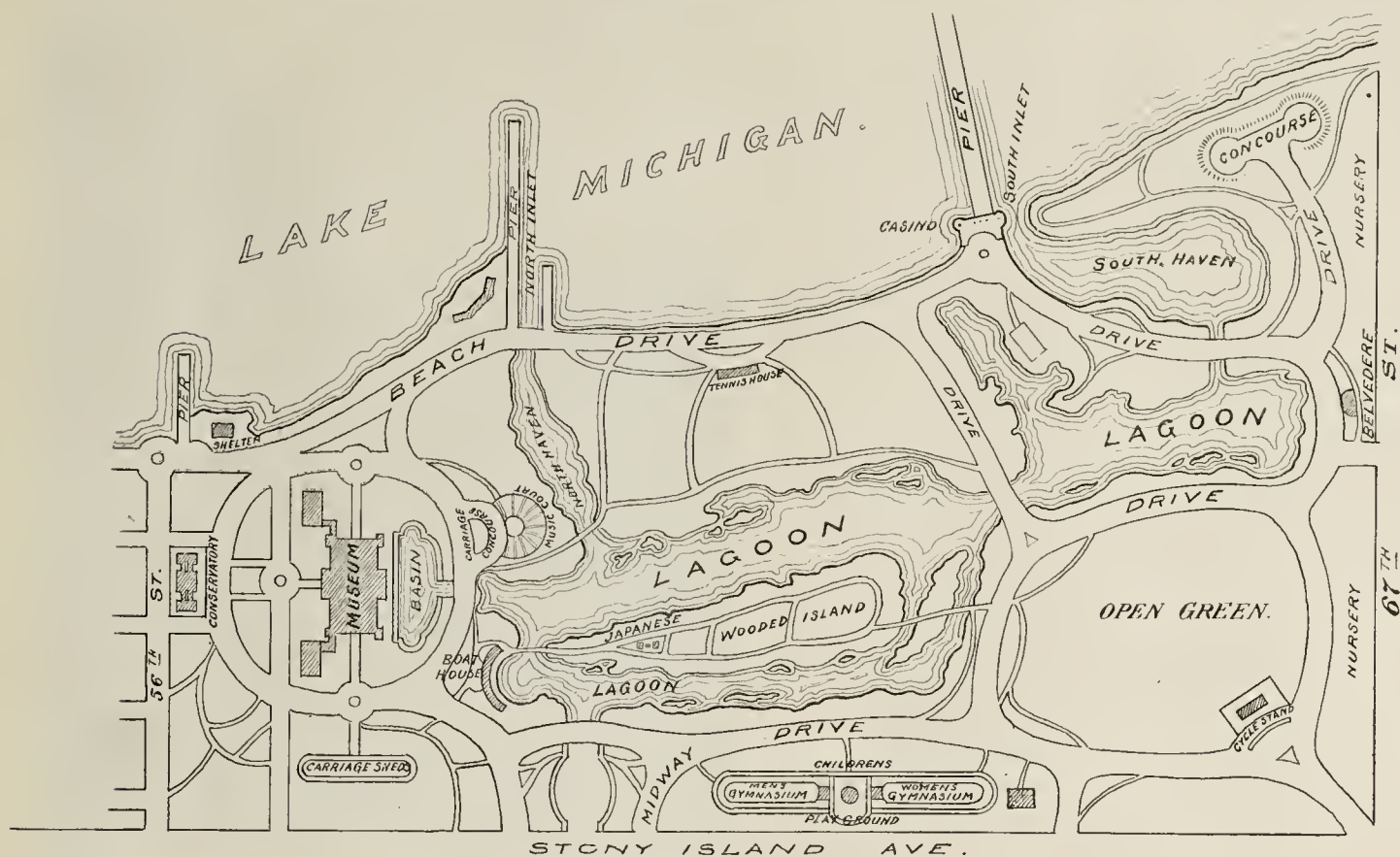
The water effects have been amplified and diversified and the system of lagoons, extending as it does in its varied design the entire length of the park, will present waterscapes of infinite variety and beauty as well as afford the most liberal facilities for boating and aquatic pleasures.

A magnificent view will be obtained from the bridge spanning the channel between the lagoon and basin at the south end of the park, towards the Belvidere tower, proposed to be erected on an eminence constructed from dredged material taken out of the south lagoon; while from this tower the whole park and its beauties may be enjoyed.

It will be seen on the plan that South Haven is open to the lake and this will afford a shelter and rendezvous, of some twenty-two acres, for sail boats, and floats and landings will be provided adjacent to the dam and lock, which is introduced to preserve the level of the lagoons against the fluctuations of Lake Michigan.

A site for a bathing pavilion is suggested on the north side of the protecting pier of the north inlet from Lake Michigan. Provision is also made for boats and launches in the North Haven, with landings adjacent to the dam and lock at its head.





NEW PLAN OF JACKSON PARK, CHICAGO.—OLMSTED, OLMSTED & ELIOT, LANDSCAPE ARCHITECTS.

The general design of the driveways is readily comprehensible from the plan given, and it will be observed, that though simple in their arrangement of easy and graceful curves, their circuit involves all the special features of the park, and includes details directly increasing their effectiveness for pleasure driving.

Wooded Island, of World's Fair fame, with its Japanese temple will be retained, and many other smaller islands made to diversify the shore lines, which have been very carefully studied.

Turning to the recreation facilities; at the south-west corner of the park will be the great playground of sixty acres, affording opportunities for all kinds of games. A bicycle track will girdle it and a running track will form another feature. A bicycle stand, carriage shelter and general building will sooner or later be erected at the south-west corner on rising ground. This magnificent lawn with its surroundings will be an invaluable addition to the landscape of the park.

Where the great Manufactures Building once stood, some twenty-four acres will include tennis grounds on which buildings to meet the necessary requirements will be erected in due course.

In the area lying between the drive and Stony Island Ave., the western boundary, the scheme proposes an elaborate arrangement of gymnasiums for both sexes, with the appropriate buildings, and a childrens playground with accessories. These feat-

ures of the public park have been for a long time popular in Europe, and in Boston in our own country. In this section of the grounds, headquarters and buildings for other purposes connected with the care and management may be located.

The foregoing gives a skeleton idea of the informal portion of this great park, and turning to the north end, the Art Building, now the Field Columbian Museum, which is 1200 feet long, practically dominates the further design, and it will be seen that the lines are formal, to be in keeping with the classical style of this beautiful structure. This treatment extends from the north end of the main lagoon. It is designed to span the channel, which connects the main lagoon with the formal basin, (8 acres,) with an architectural bridge standing on the main axis of the Museum.

North of the Museum and adjacent to 56th St., the plot is reserved for the conservatory, and whatever elaborate floral display may be proposed, it is suggested that it may be disposed among the formal lines of paths and roads in this neighborhood.

Music, in relation to park pleasures, has not been forgotten, and a choice location has been suggested and designed to accommodate its requirements.

Carriage sheds are provided for, to be disposed of in a partially concealed shrubbery scheme, west of the Museum.

At the south end of the park, the land between



the main drive and boundary line will be used as a nursery.

Nothing has been said above concerning the planting and use of trees and shrubbery, but it will all be provided for in a most thorough and artistic manner. The shores of the lagoons will be planted with shrubbery down to the waters edge as a general idea, with variations to improve opportunities. Over a quarter of a million of dollars will be spent on the work this year, and it is proposed that the portion of the park north of 59th St. will be completed as far as possible. Some work on the tennis and ball fields will also be done.

Nothing is shown on the plan in relation to the well known Midway Plaisance, which runs west from Jackson Park from the point indicated. Active work on this parkway has been in progress for a year past and the design for its improvement will make it as interesting as any portion of the park system, of which it will form an integral part.

#### **The National Cemetery, Vicksburg, Miss.**

It was late afternoon of a golden June day in the latter part of April that I first saw the exquisite place known as the Vicksburg National Cemetery. This sentence, seemingly paradoxical, is strictly true to the facts. By the calendar it was April 26. By all tangible evidence it was northern June with many charming additions thrown in by a generous southern climate.

We drove out of the town which rises up the face of steep hills, by the lower drive, known as the "river road," a driveway bounded on one side by the Mississippi and on the other by stony cliffs, the face of which has been cut away to make the road; but which has been made so long that much of the facade is draped with honeysuckle vines that seem to be tumbling over from the gardens above.

Occasional breaks in the bluff, made by ravines running at right angles with the river, make room for two or three ramshackle homes of colored people. These are placed at picturesquely precarious angles and are reached by long flights of steps leading up from tiny enclosures crowded between the roadway and the embankment; and, to complete the picture, the queer little buildings are frequently clothed with vines quite to the gables, usually honeysuckle vines. So that the impression brought away is of a vine-draped way fragrant with the delicious perfume of those quaint, wayward and always delightful old fashioned flowers.

The road rising gently, passes at last between trees to the stone entrance. Over the gate the inscription reads:

National Military Cemetery,  
Vicksburg,  
1864.



ENTRANCE, VICKSBURG NATIONAL CEMETERY.

While on the inner side of the same tablet it is recorded:

Here are buried 16,600 citizens who  
died for their country,  
1861—1864.

But once the entrance is passed one scarcely thinks of what the place is for—what it *is*, is enough. And it is a place apart; it is, or seems to be, the place where the wicked cease from troubling and the weary are at rest. It is the place of Peace. Peace broods over it like a spirit made tangible. In that atmosphere, War is an element so foreign that it is difficult to include it in ones thoughts.

The grounds run up the side of steep river hills, almost bluffs, the top of each succeeding rise having been leveled to make spaces for graves, so that there is a series of open glades of different sizes and shapes and at different levels throughout the enclosure. The hills have in fact been terraced according to their natural contour, and the wild beauty of the site preserved while being also skillfully adapted to its purpose as a Cemetery.

I have been unable to learn who deserves the credit of the work, but from the points of view of Engineer and Landscape artist, it is most creditable. The one noticeable defect is the use of prominent stone markers, but the graves are level so that the turf of the glades is neatly cut.

It is a pity that where there is so much to com-



mend, and where nearly every feature of the lawn plan is carried out to perfection, that inconspicuous markers were not chosen; the more so because each one bears only a number which would be accommodated as well by small stones set in the ground, so that the lawn mowers could run over them.

And certainly no stones are needed as reminders of the purpose of those sylvan glades walled by evergreens on the abrupt edges of the cut embankments, and beautifully planted with many varieties of trees on the easy slopes; glades where the grassy covers spread over the sleepers are almost perpetually green; where the long shadows seem to follow each other even more quietly than elsewhere; and where birds and flowers hold undisputed possession. All about the enclosure, up hill and down, runs a paneled wall of dark red brick, that, while less picturesque than one of stone or boulders, is in keeping with the place and by no means unpicturesque with moss patches here, half hidden by a fragrant burden of gracefully piled up honeysuckle there, somewhere else covered by clinging English Ivy, and again embowered in climbing roses—Marechal Neil being prominent.

There are beautiful trees so placed as to leave sunny expanses, as well as lovely views from the few well placed drives, not only views within the grounds but out over the lower hills across the wide river. My visit was too brief to make more than a cursory round of the grounds so that I am unable to give a detailed account of the trees and shrubs that were growing luxuriantly. But there is a great variety of deciduous trees among which I noted China trees that are grown in every southern city, often being used as street trees. These are in bloom every spring, being filled with large clusters of lavender flowers that are succeeded

by berries that remain on the tree until the next flowering season and I don't know how much longer. Many fine Magnolias (*M. Grandiflora*) are scattered through the enclosure. But my enthusiasm was especially aroused by the uniform excellence and great beauty of the Red Cedar and *Arborvitæ* trees that abound. They are used as a wall of foliage at the top of banks that have been cut down sharply to make roadways up the steep hills, also in some other locations. Every tree seems a symmetrical specimen, and the effect of the pyramidal *Arborvitæ*s, their mathematical divisions of dark green growth etched in regular patterns by the bright green of the new growth, and the perfectly shaped tall cedars covered with a shower of delicate silvery blue berries almost from top to bottom is a picture not to be forgotten.

At intervals along the well made, perfectly drained roadways bronze tablets are placed which bear martial epitaphs, all rhymed, as:

“The muffled drum's sad roll has beat  
The soldier's last tattoo,  
No more on life's parade shall meet  
That brave but fallen few.”

And inside the entrances, as well as near the dwelling of the Superintendent, cannon standing upright with a ball on the mouth of each, are placed as monuments. But neither martial epitaphs nor war-like monuments can revive war sentiments in the atmosphere that time and taste have created in this lovely place.

The peaceful stretches of grass, shifting shadows and noble trees appeal to the eye as the martial emblems do not; and the subtle perfume of flowers is more penetrating than dim memories of war. We know what it all means—it is right that we should recall it—but we feel that *now* there is Peace. The very Cedars are decked with a graceful fruitage of berries that combine the two hues held dear by those who sleep below, for they are beautifully blue yet silvered over with a soft gray bloom so that one can scarcely say whether they be blue or gray. Nature herself has fused the colors, and produced something more beautiful than either; something symbolic not of the North nor of the South, although partaking of both, but better than either—an undivided country.

*Fanny Copley Seavey.*



GRASS GROWN GRAVES AND LONG SHADOWS.

The beadle in a rural district in Perthshire, Scotland, had become too feeble to perform his duties as minister's man and gravedigger, and had to get an assistant. The two did not agree well, but after a few months Sandy (the beadle) died, and Tammas had to perform the last service for his late partner. The minister strolled up to Tammas while he was giving the finishing touches to the grave, and casually remarked: "Have you put Sandy weel down, Tammas?" "I have that, sir," said Tammas, very decidedly. "Sandy may get up, but he'll be among the hindmost."—*San Francisco Argonaut.*



**How to Make and Care for a Lawn.\***

We always base much importance on preparatory work, especially the lawn, hence the importance of the care taken in starting a new lawn. The formation of a lawn is often hastily and imperfectly done. Mode of preparing is often controlled by the position and location of the ground, also the season. Excellent results are obtained by preparing and seeding in September, south of northern New York, and from September 15th to October 15th south of Maryland; but in the majority of cases this work is done in early spring in every locality as soon as the frost has come out of the ground sufficiently to allow working, which should in all events be dry.

Any piece of ground to be put down in lawn, whatever condition it may be in, requires plowing, deep harrowing and equalizing; deep harrowing is important where the soil should form into hard lumps after plowing. This method lifts out the clods, allows the fine soil to fill in the crevices which would otherwise fill after heavy rains when the seed is sown and lawn finished. The above will apply to any location of a slope, even slight, but should the location be flat and level, draining is a requisite; this can be done even by rubble or tile. An undulation or a gravelly subsoil will alone insure sufficient drainage. The depth of soil is an undecided point. It is believed, and wisely too, that on high points and knolls the soil should have a depth of at least 12 to 15 inches to endure drouth, whereas on a level it will sustain its requirements at a depth of 8 inches.

During preparation the question of fertilizing is the next consideration. Should the ground be in a fair condition through previous fertilizers applied, a coating of pure ground bone (600 pounds per acre) will suffice. We believe pure ground bone to be the best constant feeder—this to be applied at time of seeding.

The ground having been plowed, harrowed, leveled and raked into a smooth, even surface, is now ready for the seed. The fertilizer having been applied and thoroughly incorporated prior to the finishing, the seed is sown at the rate of three and a half to four and a half bushels per acre; (this means twenty pound bushels) the sowing to be done by hand, all grasses thoroughly mixed before sowing. Should it be required to sow wheat, oats, or rye with the grass, this should be sown at the rate of one bushel per acre, broadcast, and harrowed in lightly, then the grass seed sown. It is not claimed for the wheat, rye or oats to protect the grass during winter or shade it during summer, but to help in build-

ing the sod and keep the surface in a condition to absorb all the nutriment of the decomposing fertilizer, as well as absorbing the nitrogen from the atmosphere. After the seed is sown, a careful raking with a wooden hand rake lightly drawn over the surface evenly distributes the seed and lightly covers it. Now must be done the most important of all the work, and that is the rolling.

The condition of the surface at this time is just what it will be as a finished lawn; all alterations after this are tasks with poor results. If the lawn is sown in the fall, a covering of tobacco stems will prove a great benefit, especially if the soil has not had a coating of hard wood ashes, the tobacco stems will supply the amount of potash and ammonia, which will give the lawn new life. If sown in spring, a covering of well rotted manure finely sprinkled all over about March 15th, and allowed to remain a month will give the needed food and shading. In raking off the covering use a coarse wooden rake, thus allowing a fine mulch to remain.

What seed to sow: There are many confusing suggestions regarding this. Some advocate annual types and seed each year; but it is conceded by all experts and authority that perennials of tried sorts are the best. Avoid all Canadian grasses: they are coarse and not very carefully harvested, but excellent for pasture.

In our Fairmount Park we have some of the finest plateaus of grasses which have endured drouths, and have been cut every week. These mixtures contain perennial rye, Kentucky blue, sweet vernal, extra cleaned red top, natural green and white or Dutch clover. Italian rye is also frequently used, being a very free grower, somewhat coarser blade, but constant mowing keeps it in condition to present the appearance of a finer grass.

It is customary to use sod on all borders and on terraces. The sod should be laid at the borders so as to be about half an inch below the surface of the soil; this is to be done before seeding. After a thorough rolling the soil is brought to a level with the sod surface. The manner of laying sod is left to the judgment of the experienced. The bevel system having been practiced a long time is a good one, provided it is laid in the fall or early spring; but after April 1st it is better to cut it square and thick, and lay very closely, fill the remaining crevices with good soil, and give a light sprinkling of grass seed, this will prevent burning the edges. Laying sod on steep terraces is successfully done by using pins eight to ten inches long, (two to each piece of sod,) and driving through, this will necessitate a thorough beating down of the soil before laying the sod hard enough to guard against washing and loosening.

\*A Paper by J. O. Thilow before the Eighth Annual Convention of the Association of American Cemetery Superintendents,



Mowing should be done at least once a week in favorable growing weather, and even in dry, warm weather it should be cut twice a month. If the lawn has been properly made in the first place, and top dressed, the weather will have to be very dry to prevent its growth. The best mode of maintaining is the care given at proper times. In the fall it is necessary to give a good scarrifying; this is done with a sharp toothed rake made for that purpose. The operation is called cultivating. If the grass shows thin in some places, another light sowing should be made, then cover with tobacco stems if the space is not very extensive, or give a coat of Kainit. This should be applied in December. The scarrifying process may be done again in the spring, but not very heavy, merely enough to give a good combing all over. If top dressing can be done, good rotted manure may be used, allowing it to lie from March to May, and then raked off with a coarse rake.

Weeds are offensive and unsightly; cutting out of the large ones is sufficient, as the smaller ones are choked out by constant mowing. The means of perpetuating and caring for a lawn is open for improvement, also varies in different localities. Where fertilizers containing pure bone in majority can be secured at small expense it is advisable to use, and avoid manure from the stable because of its weed producing.

Mr. John G. Barker, Supt. Forest Hills Cemetery, Boston, gives the following in *Gardening*:

TOPDRESSING THE LAWN.—We do not use stable or farm yard manure for this purpose for two reasons, first because it is unsightly, secondly, because it certainly introduces the seeds of weeds, and this we wish to avoid. On a smooth lawn that needs enriching we use commercial fertilizer, 600 or 700 pounds to the acre, with exceedingly satisfactory results, using an Acme Fertilizer distributor, which can be readily adjusted to spread any required amount, of course the dressing may also be sown from the hand. [Mr. Barker doesn't mention what brand he uses, but we know he uses both the Bradley and the Bowker lawn dressing.—ED.] I shall topdress our lawns now just as soon as the frost is out of the ground enough to let the workmen walk on the grass without leaving the impress of their feet. The spring rains will wash the nutriment into the soil. After topdressing we roll the lawns to make them smooth for the mowing machine.

UNLEACHED WOOD ASHES.—I use this as a topdressing with good results, especially where moss and chickweed grow among the grass. A good dressing two years in succession will very materially lessen if not eradicate both of these pests and give a good sole of grass.

#### Public Parks and Pleasure Grounds.

It is a simple matter to form public pleasure grounds if they be entrusted to the right kind of men, and are carried out on common sense principles.

The selection of the ground is the first thing, and here I would say that very much better might often be done for the people. A suburban farm may often be bought, levelled, ploughed, sown and planted, for a less sum than some commissioners spend in preliminaries. Farms, too, that are sure to be soon reached by the electric cars.

Every community, however, will vary in its needs; for instance, towns having large Schools may reasonably demand educational features in their park planting. It is entirely feasible to select farms which embrace a stretch of native woodland, well adapted to pleasure ground purposes, where people may go where they will and do as they please, within orderly limits, and containing also cultivated tracts suitable for the planting of a classified collection of trees and shrubs in agreement with modern science and Gray's Botanies—constituting arboreteums, or with herbaceous plants added—constituting botanic gardens. These must be fenced and protected. Large cities with populations confined during the day to mercantile and manufacturing pursuits, will naturally demand streets adapted to pleasure driving, and a larger and more comprehensive variety of public grounds, perhaps embracing all of the varieties I have mentioned above. Where there is abundant wealth, public conservatories may be added and large sums of money spent in these and other less useful architectural features. It is not productive of the best results, however, to lavish money on immense barns of conservatories such as the World's Fair arrangement. Such buildings can rarely be furnished or maintained properly—no matter how extravagant they are in first cost. It is far better to be content with a small conservatory, and provide liberally for a number of structures such as commercial florists use, in which to grow a succession of plants to furnish it, and produce a flower show for every season of the year. Such is the true economy both in first cost, subsequent management and satisfactory results. If any of you have visited Kew Gardens you will remember that the *flower* houses are not very large or expensive, but they are full of flowers all the year through because they have a nursery of glass to supply them every week with a fresh lot of plants, therefore the show house keeps as gay as a florist's window, but with a far greater variety. I may mention that these gardens attracted 1,733,389 visitors in 1893, that they cost about \$125,000 per year for maintenance, that they prepare hundreds of men



for service in the forests, plantations, and gardens of the British empire; that among other good things quinine has been cheapened to the world through their agency, that the Island of Jamaica has been stimulated as a tropical fruit centre through them, and that the botanical economies and garden science of the world centers there. The British Parliament would no more permit a commissioner of works to interfere with their directorship than it would permit him to interfere in Hyde Park or pull down the Tower of London. His function and the function of his office is such as may easily be assumed by any city controller, or other municipal body controlling finances.

The spectacle presented by some of the park boards operating in the various States is unique in the world. The park board where I write has never contained a single man who knows anything about a park, or a plant it contains.

Politics have no more business in a public park or garden than they have in the management of the geological survey or the management of a College.

Enough has been seen of extravagance in design and management.

Let the mayors and common councils have power to employ good city gardeners from the beginning. There are numbers of them in America that have more force, knowledge and ability in such matters than all of the park commissioners of the country put together. Place your men under such city department as best suits you, let them advise you, give them power to employ and discharge their men, if you expect them to be obeyed. Don't surround them with spies, bums, and toadies, and my word for it, we will soon lead on the park question.

To recapitulate somewhat, don't be extravagant and spend millions on land to grow an unmanageable lot of taxes for generations to come, but cut according to your cloth.

Remember the rising generation, they need educating in the management and uses of public grounds, and in forestry. They can learn about plants better in parks than on paper.

Remember, finally, that you can reach out to the country for cheap and good farm lands more and more readily every year, and that you can often buy a farm and make a park for less than some ornamental commissions spend upon junketings and preliminaries. Many a good farm can be bought near country towns for less than \$100 per acre today. Then why spend thousands in the courts and in condemnation proceedings? Such paper work doesn't provide recreation for the people.

Trenton, N. J.

*James MacPherson.*

#### Oak Grove, Cemetery, Bath, Maine.

From the accompanying illustrations even more than the text of this article, it will be seen that they are not deficient in taste and skill applied to landscape work in Cemetery arrangements, "away down east in Maine."

The city of Bath, for a century leader of the world in wooden ship building, singularly enough, while producing year after year the most graceful and beautiful of clipper ships, paid but little attention to any, save the simplest of landscape work about its homes and cemeteries, until some fifteen years ago when modern ideas began to animate its citizens, and, among the first results, was the inception of a plan which, under Bath's present superintendent of Cemeteries, has made Oak Grove one of the show places of the State.

In this gem of a "City of the Dead," located in the western suburb of the city of about 8000 population are 40 acres—only one half acre being laid out for single graves—originally wood pasture and swamp or meadow land. Through its centre now runs the public road bordered by a luxuriant growth of Norway spruce hedge, and from which gently rising to a considerable elevation are the two sections of the Cemetery, east and west.

Of the 40 acres, seven are in lakes and running water, the water chain extending north and south parallel with the city road, and on the west side the two large lakes, being superbly framed in extensive lawns of well clipped turf gently sloping to their shores. The lakes are separated by an avenue, shaded by elms and maples of a dozen years growth and the grass borders being, in summer, decorated with rustic baskets filled with flowering plants and vines, and also by parterres of flowers and decorative plants, coleus being extensively and tastefully employed. A handsome rustic bridge crosses the south lake, while in the north are small islands connected by little bridges and containing rustic vine



VIEW IN OAK GROVE CEMETERY, BATH, ME.





VIEW IN OAK GROVE CEMETERY, BATH, ME.

covered seats and arbors; in summer being planted with tropical plants. In both lakes are thousands of gold and silver fish, and in the warmer months on the placid surfaces of each swim swans and ducks of handsome plumage.

In 1894 the water chain was extended northward by the purchase of more swamp land adjoining; and through this bog, partly to serve as drainage and partly to add to the landscape, a little river has been run emptying into the northern lake. In this addition, as much as possible of the natural wood was retained and through the swamp an isolated drive and promenade was built, skirted by the meandering river and with here and there beds of flowers.

This drive is called Aquatic Avenue, taking its name from the chic little water way and from the aquatic plants, pink pond lilies, triterae, water ferns and other plants, both rare and common, but all pretty which grow therein.

On the summit of the rising ground to the northwest is a rockery, topped with the handsomest rustic summer house in Maine, and, on the western boundaries, up hill and down through the original forest, runs another handsome avenue charming as a promenade or drive.

Throughout the Cemetery, as much of the original forest growth, (oak, maple, birch and fir,) as served, has been saved and, in addition to many nat-

ural clumps and groves of Sylvan beauty, have been planted and successfully grown, groups of shade and forest and ornamental trees.

Supt. Ramsay's aim has been, in all improvements and changes, to adhere as closely to Nature as possible, and to avoid artificial effects. Further, there has been great care and nicety of touch in producing the combination of lawn and woodland with marine surface. Nothing has been overdone while much has been accomplished with very little money.

Of the illustrations, one is of the main island of the north lake which, 200 ft. in circumference, is planted with an outer circle of calladium; next, cardinal; next, cannas; and last, ricini. This plant arrangement has a growth in one summer of from six feet on the shore to 20 feet in the centre with a most pleasing and tropical effect.

Another view is that showing the entrance to the Cemetery and part of the hedge already mentioned as fencing the east and west sections from the public avenue. The hedge is of Norway spruce and 800 feet in extent on each side.

The management of the Cemeteries (and also public parks) consists of three trustees, one elected to fill the annual vacancy occurring, by the city government. To this board the Superintendent is responsible.



Previous to 1880 the cemetery was sadly neglected. Lots were sold—rather given away; some graded and cared for their lots but the majority did not. At the date mentioned the city passed an ordinance charging for lots of 200 square feet, a price not exceeding \$20.00, which price has been and is now that charged for the best; those not so desirable bringing lower prices down to \$5.00 each, which latter figure is perhaps a great mistake.

The annual appropriation is small and the lots being so cheaply disposed of, too scant an amount of money is realized for assistance in making improvements.

The sale of lots annually amounts to about \$600 and for care the average is about, annually, \$800. For perpetual care there has been paid about \$7,000. Lots are sold only to citizens, unless a special grant is made to a stranger who then may purchase by depositing not less than \$50 for perpetual care.

Before 1880 few citizens or strangers cared to visit Bath Cemeteries save to bury their dead, but now in spring, summer and autumn, on pleasant days, visitors are numbered by hundreds, and Oak Grove serves as a public park as well as burying ground.

Six years ago, the building including the office and conservatory and located in Maple Grove Cemetery adjoining, was burned, but a substantial office and green house was re-erected upon the same site.

Though nature had done much for Oak Grove, its growth in beauty year by year from a pasture on the hill sides to a park as tasteful as any, (if not superior to all,) through not so extensive or so well financially endowed as some in Maine, is due chiefly to the taste, ability and skill—and untiring industry of its Superintendent, John H. Ramsay.

C. D. C.

---

#### Planting on Graves.

Although it may not be strictly in accordance with the most modern ideas of good cemetery management, allowing graves to be raised above the surface and planted with flowers, or foliage plants, yet the system will prevail more or less, especially in smaller or rural burial grounds; where, however, such is practiced, it will be as well to try and secure uniformity. Nothing can look worse than indiscriminate planting upon graves; and nothing more seriously marring the general appearance.

In the first place planting will be useless unless the grave is properly prepared. To do this the dirt should be removed to a depth of about eighteen inches, and replaced by rich, well pulverized soil, which should be pressed down firmly with the foot—but not sufficiently to make it hard—till the fill is level with the surface. With the aid of a straight-

edge, or piece of narrow board, trim the edges of the grass with a sharp knife. The margin of the sod can be slightly raised, by inserting a spade and forcing a little soil underneath, pressing the sod down again upon the earth. This will give a raised appearance to the grave.

In places where mounded graves are permitted, a grass edge or border will greatly add to the appearance. To do this neatly will require a little practice. By attending to the following instructions any person may soon become expert. The soil in the grave having been packed, cut strips of matted sod, without any clover roots if possible. These strips should be of the same width that it is desired to raise the grave in height, and should not exceed 4 to 6 inches, the former being preferable. Lay the straight edge along the side of the grave, and place the strips of sod on edge upon the soil, giving it a slight slope upwards, and joining the pieces together on the under or dirt side with small wooden pegs about the size of a lead pencil. The same should be done with the ends. Mind and press the sod firmly into position,—pounding with the fist is as good a way as any. Having made the border or box, hold the straight edge along the top, and with a sharp knife trim the edges, also cut away the dirt side for an inch or so, to form a sharp edge. Now fill in with fine rich soil to which has been added a hand full or two of bone dust. Rake off the top and it is ready for planting.

When graves are raised more than 4 to 6 inches above the surface, the more difficult it will be to keep the grass boxing green, as well as also keeping the top soil sufficiently moist for the well being of the plants, without excessive watering,—to say nothing of the neat appearance if the graves which are raised just enough to distinguish them. If the grass on the boxing is kept well clipped, it will add much to the appearance, and is essential to the appearance of an ornamental grave.

In the early part of the summer pansies make a pretty covering for a grave, and in locations where they will not winter-kill, violets are beautiful. But the principal planting will be for summer and autumn. Some of the prettiest effects can be obtained with *Alternanthera*, which being of dwarf and compact habit, enables close planting. Their beautifully variegated foliage of crimson, purple, yellow, pink and green, form rich masses of color always pleasing and attractive. The patterns or devices must be left to the individual taste. A charming effect may be obtained by the use of a border of *Echeveria*, about the size of a half a dollar, planted between the boxing and the *Alternanthera*. Or letters or words can be made, either diagonally or lengthwise of the graves, and the remainder of the



space filled in with *Alternanthera*. The number of patterns that can be formed are too numerous for mention here, and can be made to suit the taste and pocket of the lot owner. To get the best effects from this class of work will require that the flowering shoot be picked off, and the *Althernanthera* frequently trimmed to keep the plants dense. If this is not attended to regularly the stems will grow coarse. There is more danger of spoiling the appearance by not trimming than from over trimming.

Pretty planting can be made with a border of *Achyranthus* and the remainder of *Madame Salleroy Geranium*, very dwarf in habit, foliage light green edged with creamy white. The contrast in this planting is very decided. A nice looking and cheap planting can be made with seedling Sage plants, which must be placed rather closely together and kept well trimmed from the start. There is also a pretty variegated variety of Sage. Candytuft, *Myosotis*, or blue *Lobelia* are also pretty for covering graves and are cheap. Indeed any dwarf and compact growing plant is desirable.

*Coleus* are scarcely suitable for placing on graves, the space being too limited. To enumerate in this short article all the different varieties of plants suitable for growing upon graves would be impossible. The before mentioned will be found among the most desirable. For permanent planting, *Vinca* (*Myrtle*) and *Sedum* are the most popular. To insure a good appearance with these plants attention must be given to constant trimming and watering in order to prevent the graves looking ragged and untidy.

Chicago.

*Bellett Lawson.*

**Greenhouses.—How to Build. IV.**

In previous papers the question of a site and its preparation and the approximate size of the houses have been discussed, and we will consider that these matters have been decided upon. The next question will be the preparation of the plans.

Fig. 5 shows a ground plan of a small greenhouse establishment. If the houses are made fifty-two feet long from outside to outside of posts, a very compact and convenient structure will be obtained. It is well to make this length some multiple of eight as sixteen feet lumber can then be used without waste. It should be noted that this plan allows for gutters on both the east and west sides of the houses. If no future additions are to be made, the outside gutters can be replaced by wall plates as shown at the right in Fig 2 and 4 in the previous paper. If future additions are to be provided for on one side only, the gutter can be omitted on the other side. This will cheapen the con-

struction somewhat. The omission of a gutter will make the houses narrower by about 4 inches from outside to outside of posts, leaving the same space for benches.

The large house is shown with two doors at each end. In this case the walks and benches would run straight through the houses from end to end, with no cross walks. This is convenient and gives the greatest amount of bench room.

Fig. 6 shows a bench arrangement for the houses in Fig. 5, which will be better, when visitors are

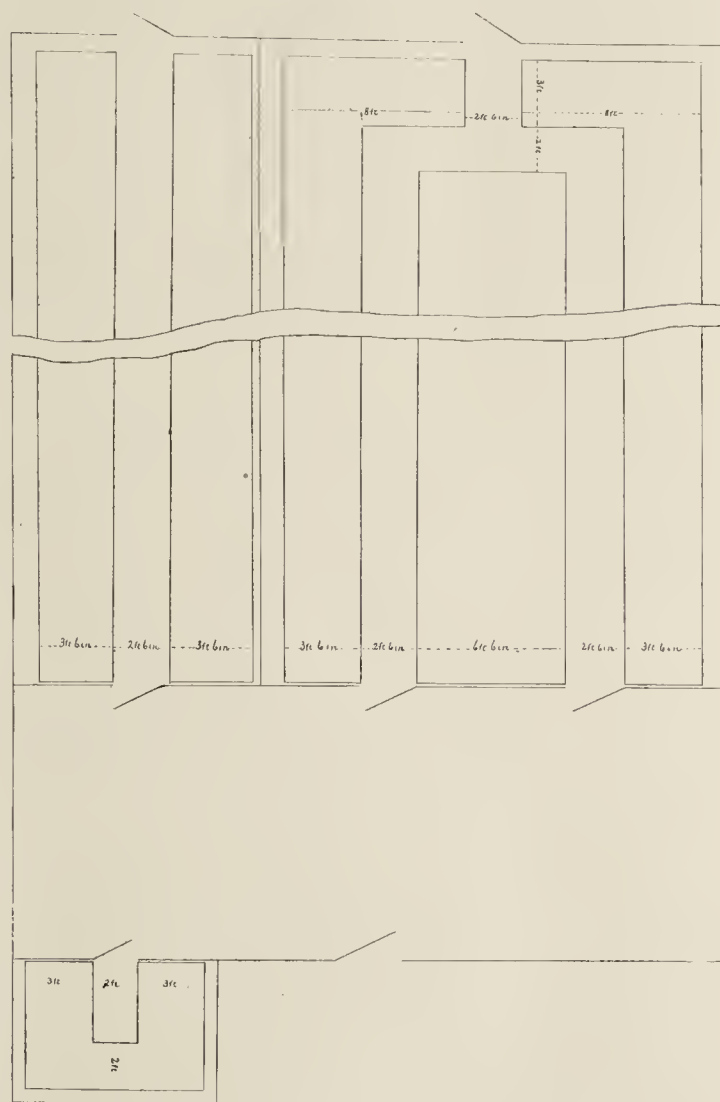


FIG. 5.—GROUND PLAN OF SMALL GREENHOUSE.

admitted to the houses, and it dispenses with one door at the south, while giving nearly as much room. The end bench is made narrower than the side benches for convenience in reaching the corner, and the cross walk being short is narrower than the others. It is the common practice to build these houses with but one door at each end, making a crosswalk necessary at each end also. This is not recommended as it is not so convenient and does not give so much bench room.

The shed is an ordinary structure with a lean-to roof highest at the south side, where it should be a few inches higher than the ridge of the large house.



Details are omitted in the plan. The roof should be shingled and sides sheathed with matched stuff; outside of this should be a thickness of building paper and the outside finished with siding, or drop siding, in the usual manner. Building paper treated with tar should not be used as the tar weakens the fiber of the paper, and in a few years it crumbles and thereafter gives but little or no protection.

The shed should be well lighted with 3 or 4 windows. The doors leading into the greenhouses from the shed are 7-8 inch batten doors. A substantial bench will be needed for potting. This should be about three feet wide, two and a half feet high and about six feet long. If space is needed for two men to pot, two benches should be built, as they can not conveniently work at the same bench. Suitable racks and shelves should be provided for the storage of pots, tools, etc., and bins for soil. The soil bins can be under the potting benches and under the greenhouse benches. If the soil is dry or can be drained, it will be best to excavate a cellar under the shed for the boiler, coal and ashes, giving more room above and shutting in the dust.

If this cannot be done, a pit must be dug as deep as possible and bricked up, the wooden floor being carried only to the edge of the pit. The pit or cellar must be large enough to contain the boiler and allow space for coal and ashes. The boiler must be well away from the walls so that it can be inspected from all sides, and a flue cleaner can be used. The room needed will vary with the size and style of boiler. It should be born in mind that *no unprotected* wood work should be nearer than three feet from the smoke pipe of the boiler.

The smokestack can be of plain or galvanized iron if necessary and run through the roof if well protected. The danger from fire however, is great, and the gases from the coal, especially if it contains much sulphur, rapidly corrodes the iron. A brick stack is much to be preferred and will be cheaper in the end. A foundation should be built for the stack of solid stone or *hard burned* brick masonry, using cement mortar, and extending down to solid ground below frost and at least six inches below the cellar or pit bottom. It should be probably a little larger than the base of the stack. The stack should be built of good brick laid in cement mortar and tapered or battered from the base up. The base should be, for perfect safety, a square, of which each side is not less than one-tenth the height of the stack. In practice the base is frequently made smaller and such chimneys do not always blow down but it is best to be on the safe side. The opening at the top of the stack should be of such size as is required by the boiler. The walls of a stack of moderate height may be four inches.

Greenhouse smokestacks are built from twenty to fifty feet above the boiler. If there are buildings or trees near, which shut off the wind, the stack must be carried higher than would otherwise be necessary. It should be born in mind that the higher the stack the better the draught.

The south and north sides of the shed should not be sided until the greenhouse and propagating house roofs are in place. The sides of the houses consist of six inch posts, set three feet in the ground spaced as shown in Fig. 5 and projecting four and a half to five feet above ground. To these are nailed one thickness of ship-lap. Common flooring is not good for this purpose as the joints are square across the wall and will hold moisture, causing decay. The ship-lap having diagonal joints, if properly laid with the upper board overlapping the under on the *inside of the house* will keep any water, when using the hose, from getting inside the double walls. On the outer walls two thicknesses of building paper are tacked, and outside of this drop siding is used. The drop siding is laid with two upper boards lapping the lower on the outside of the house and this turns all water from that direction. The top piece of ship lap is let into a groove in the under side of the gutter bottom, making a tight joint there.

The top of the posts are sawed off, after being set in a line, to carry the gutter or wall plate as may have been decided on. The gutters and wall plates, and in fact the complete houses are not set level north and south, but have a fall of three or four inches to the south in a fifty-two foot house in order to carry the water away quickly.

At the peak of each roof is placed a ridge piece extending the length of the house and supported by one inch iron pipe. The pipes are set about eight feet apart and stand on pieces of stone which are first rammed into the ground far enough to be firm. If the pipe are cut into two pieces and joined by couplings, after they are in place, they can be unscrewed slightly in order to give them a firm bearing above and below. Wooden supports, two by four inches, are often used but the lower ends soon decay, allowing the roof to sag.

From the gutter, or plate, to the ridge, sash bars are placed corresponding to the rafters of an ordinary house. The height of the ridge should be such as to give a rise to the sash bars of six or more inches to the foot. The gutter should be of such height that with the rise or pitch of the bars there will be sufficient head room over the walk. A height of four feet six inches to the sash bars at the wall and 9 feet 6 inches or more at the ridge will answer very well for the twenty foot house. The sash bars are spaced to correspond with the size of the glass to be us-



ed, and the glass is laid in rows up and down the roof reaching from one bar to the next.

The intermediate posts across the ends are four inches. At the top they carry a plate at the height of the lower edges of the sash bars at the side walls, and from this plate vertical sash bars extend up to the end bar of the roof. The door jambs also extend up to the end bar of the roof. The posts below the plate are sheathed up in the same manner as the side walls.

Usually the water is allowed to run out free at the ends of the gutters. If it is desired to carry this water away in pipes, a metal pipe, galvanized iron is best, should be run through the bottom of the gutter at the south end, and down to the ground inside the house into a tile pipe. The warmth of the house will keep the pipe from freezing and save much annoyance.

The posts should be eight feet long. Red cedar or locust are the best, but they can seldom be had at a reasonable price. Common cedar is generally used and should be live cut to be durable.

(To be continued.)

**Reform in the use of Bedding Plants.**

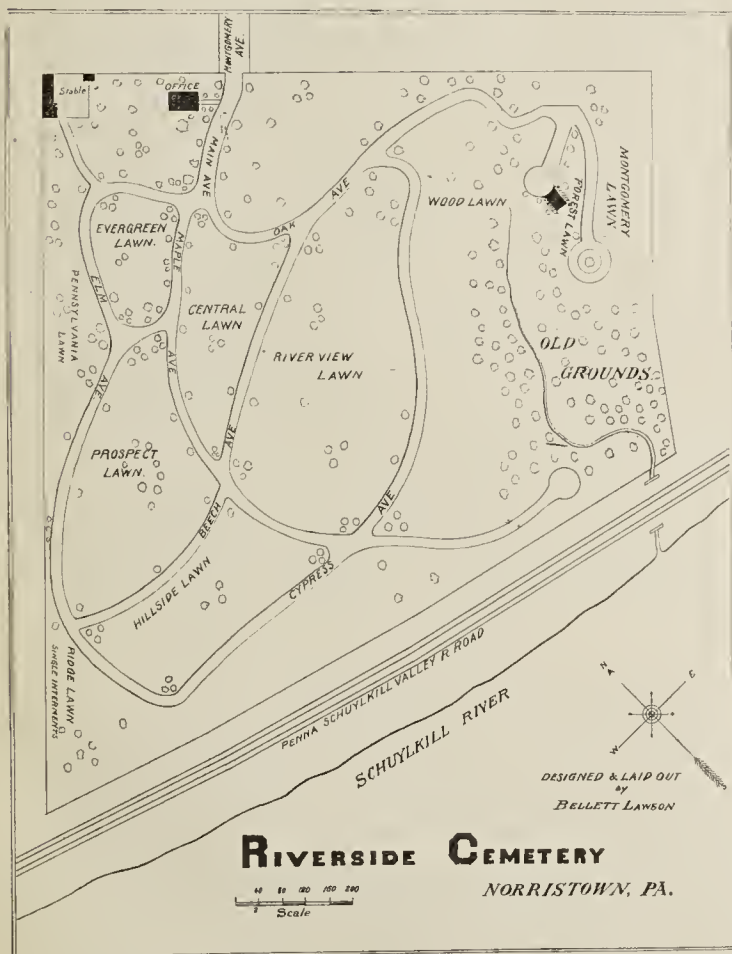
Samuel Parsons Jr., superintendent of parks of New York city, in a very instructive article in the *March Scribner*, discusses the use of bedding plants outside the stiff and formal lines which seem to have brought upon this class of plants a certain disfavor. He draws attention to their infinite variety of color and form, and to their vitality during the hotter months of the year, even when the ornamental trees themselves yield to the weather. Notwithstanding the crusades against bedding plants by people of acknowledged taste and comprehension of the landscape gardening art, everybody wants them and will have and use them. And Mr. Parsons asks: Why should'nt they?

He describes some actual practice in the employment of bedding plants in less formal lines than those which seem usually to have limited their use, and urges reform in the disposition of this class of plants as there has been in the arrangement of cut flowers.

"One of the chief reasons why many combinations of bedding plants are unsuccessful is because they are planted in the wrong place. The effect of an otherwise successful composition of form and color will be utterly destroyed if set in the wrong place."

The main features of every park and lawn are the buildings, fences, roads, paths, trees, shrubs and grass, and bedding plants can only serve for ornamentation and to supplement the effect of these principal features, if they detract from the appearance of these or limit their value they are worse than out of place.

"To say that bedding plants should be set out in strict artistic relation with the main features of the place does not mean a great deal to the reader unless examples are given, and unfortunately examples vary infinitely. It is easier perhaps to say what should not be done with bedding plants. Don't plant masses of them on the lawn so as to dwarf and divide up the main expanse of the greensward, which should be the chief beauty in every place. As a rule, don't set plants of any kind out in the middle of the lawn. A pernicious practice is to surround single shade trees with little collars of colicuses and geraniums. Avoid that, as well as any arrangement that consists of an isolated group that is properly related to nothing else but the grass. Bedding plants look particularly well adjoining architectural structures. There is something about the palm and canna that makes them specially effective planted against carved or cut stone masses as a background. They seem part of the architecture itself, ornamenting and enhancing its charms like some deftly arranged drapery. Adjoining a house



Design by Bellett Lawson, of 20 acre extension to an old burial ground. The land is slightly rolling, and has a decided slope from north to south. The circles in Montgomery lawn are designed to allow carriages to turn, until the drives can be extended across the ravine.





SALISBURY TOWER, INSTITUTE PARK, WORCESTER, MASS.

or fence, bedding generally arranges itself better than elsewhere."

Mr. Parsons shows where in the regular flower garden, bedding can be done effectively without interfering with the lawn, and how excellent effects may be produced in many directions, and further: "the landscape gardening of bedding plants does not depend on the haphazard so-called good taste by some one who simply knows how to grow plants. It is, on the other hand, distinctly artistic work, based on principles of the art that underlies every form of landscape gardening. The composition of a landscape gardening picture, just as a composition of a painting, must have a definite scheme that has not only plenty of design but a nicely adjusted relation of form and color. There must be careful study given to the treatment of foreground, middle distance, and background, and the sky lines and level effects of water and greensward must be duly considered. Not only must the relations of bedding plants and shrubs be considered, but the composition of the individual bed of plants must be carefully worked out. You must have a system and be governed by certain general rules, but there must be no mannerism or adherence to any hard-and-fast line of treatment. Every new problem must be studied with regard to its own inherent peculiarity."

#### **Salisbury Tower, Institute Park, Worcester, Mass.**

The Park System of a city should be one of its chief attractions; and its adornments are a sure indication of the intelligence of its citizens.

Visitors can easily gauge the standard of art in

a city, by its statues and monuments, or the embellishments of its parks, and there can be no question as to the advantages to be gained by the attractiveness of parks, inducing as it does, outdoor exercises among pleasant surroundings, and with elevating influences.

The City of Worcester, Mass., is well provided with Park lands, comprising upwards of 360 acres in various sections of the city, all of which are undergoing improvement from year to year.

Institute Park, situated in the northwest part of the city, contains some eighteen acres, and is a gift to the city from Hon. Stephen Salisbury, one of its most liberal and public citizens. At his own expense he has graded

and beautified it, providing among other things a band-stand, boat-house and boats, and has constructed a tower which in appearance is almost an exact reproduction of the Old Stone Mill at Newport, R. I. of historic fame. The accompanying view of the tower was taken by Mr. Albert H. Chaffee, of Worcester. It is 30 feet high and 25 feet in diameter, and has a circular stairway in the center, leading to the top, from which beautiful views can be had in every direction. This Park takes its name from its proximity to the Polytechnic Institute, one of the higher educational institutions of Worcester, and to which also, Mr. Salisbury has been extremely liberal.

Elm Park, which contains about 88 acres, has had considerable attention bestowed upon it, by creating artificial lakes and landscape effects with plants and shrubs, altogether a very lovely breathing spot.

The obsequies of Victor Hugo, which according to foreign reports, by his own wish were to last ten years are concluded. Since 1885 his coffin has lain on a black draped bier, in the crypt of the Pantheon, Paris, with the funeral wreaths piled about it. This bier stood by the empty tombs of Voltaire and Rousseau, and near the "echo" stone. Last month the coffin was placed in a sarcophagus and deposited in the niche reserved for it, a stone wall only separating it from that of Carnot. The great writer must have had a higher motive in view, than a first glance at this strange desire would suggest. Surely it was not vanity that prompted such a request.



◁ PARK NOTES. ▷

The park system of Minneapolis, Minn., comprises 1500 acres.

\* \* \*

A scheme has been approved for a park at Birket's Hollow, Peoria, Ill.

\* \* \*

A new park, Indian Mound, will soon be opened to the public at Hannibal, Mo.

\* \* \*

The Park Commissioners of Scranton, Pa., are contemplating the extension of Nay Aug Park.

\* \* \*

By the gift of Levi W. Phelps, of six acres of land, Ayer, Mass., has an opportunity for a park.

\* \* \*

Rockland, Me., is considering a suggestion of Mr. John Jones respecting a fine location for a public park.

\* \* \*

Plans have been made for the improvement of the public square at Tyler, Tex., so as to convert it into a park.

\* \* \*

Among the annual appropriations of the city of Concord, N. H., is an amount of \$6,600 for parks and cemeteries.

\* \* \*

Newburyport, Mass., has its park benefactor, and Fountain Park is the object of continual improvement at his hands.

\* \* \*

Plans are being considered by the Park Commissioners at Cambridge, Mass., for the improvement of Winthrop Square.

\* \* \*

The Lincoln homestead, in Larue County, Ky., has been purchased by an association at Hodgenville, to be converted into a public park.

\* \* \*

Property owners about Demong Park, Syracuse, N. Y., have decided to raise \$2,000 for a fountain for that park. An example worthy of emulation.

\* \* \*

One electric light is better than half a dozen policemen in maintaining order in a park, says Mr. Wm. S. Egerton, Superintendent of Parks, Albany, N. Y.

\* \* \*

The Illinois House of Representatives has unanimously passed the bill appropriating \$35,000 for the repairs and care of the Lincoln Monument at Springfield.

\* \* \*

Hyde Park, Mass., has made an appropriation of \$21,000 for the purchase of thirty acres, known as "High Rock," in the northern part of the town, for park purposes.

\* \* \*

A park ordinance which has been introduced in the city council of Decatur, Ill., provides that a tax levy of two mills on the dollar shall be made for park and boulevard purposes.

\* \* \*

Within the past year Hartford, Conn., has received gifts of three large parks. With two of these sufficient money was left to improve them in the best manner. One donor gave land, another land and money, the third money to buy and care for the land.

\* \* \*

The *World*, New York, says: Some residents of the Corlears Hook neighborhood, who have trees and plants in their back yards are missing some of them, and have traced them to the spacious square at Corlears Hook. They say it is all the fault of the poorer classes who insist on having the park constructed in spite of the delay by the city authorities.

\* \* \*

The improvements in progress in Rogers Williams Park,

Providence, R. I., include an eight mile boulevard skirting a chain of lakes, which cover some 113 acres and have a 2¼ miles straight course. One of the islands in the lakes is 32 acres in extent and this will be made attractive. It is expected that a large revenue will be derived from the water features.

\* \* \*

The method of continuous maintenance was tried on the park boulevards of Albany last year, instead of the usual system of periodical attention. A man was put in charge of an avenue to cut grass, clean up debris, clear gutters and to report repairs needed. According to the report of the superintendent this method gave greater satisfaction and was more economical.

\* \* \*

It is becoming an exception to take up a newspaper of any importance without finding some space devoted to park matters and all over the country there is manifest an increasing public interest in this important branch of community economics. We are living in an enlightened age of which the growing tendency to increase and improve the public park is a sure indication.

\* \* \*

The Sheridan road, a magnificent driveway to skirt Lake Michigan from Chicago to Waukegan, a distance of 36 miles, is progressing satisfactorily. The scheme is one worthy of consideration by all our larger cities, having favorable conditions for such an addition to its park and boulevard system. It varies in width between fifty and one hundred feet, connects with the grand boulevard scheme of Chicago, and en route, utilizes all the bluffs and ravines on the lake shore to produce picturesque effects.

\* \* \*

Some time ago the legislature of New York appropriated \$250,000 for the establishment of a Botanical Park, on condition that \$250,000 more should be raised from private sources. It was recently reported that all but a small amount of this sum had been secured, which with another \$250,000 to be given by New York City, making in all \$750,000, should possibly provide one of the finest parks of the kind in the world. Two hundred and fifty acres lying on both sides of the beautiful Bronx River are to be laid out, and when completed will undoubtedly surpass any of the few parks of like character in the country.

\* \* \*

The Pennsylvania legislature in 1865 appropriated \$26,000 to acquire and preserve Valley Forge. The act proposed that the intrenchments, redoubts and fortifications, of which there are considerable remains, shall be maintained as nearly as possible in their original condition as a military camp. Title has been acquired to over 200 acres, but the commission asks for more funds and authority to extend the boundaries to include the outer intrenchments of Valley Forge camp,—an increase of some 300 acres. This park would enclose the whole of Washington's winter quarters. A further sum of \$50,000 is asked and public approval seems to be at the back of the commission.

\* \* \*

The Essex County, N. J., Park project of which an extended account was given in our last issue, was carried by a majority of 20,000 on the election on April 9. This wisely developed scheme received a cordial endorsement from press and people and comprehensive as it is, taking in a whole county of varied topography, and covering a proposed acreage of 4,500, its progress will be watched with much interest. The amount to be raised within a limited number of years is \$2,500,000, which is small considering the condition of the county. The plan outlined comprises four large parks to take in the best topographical features of the county with the finest natural scenery, to be connected by parkways, broken at intervals by smaller parks to form breathing places in the more thickly populated locations. The scenery of Essex County includes the bold trap rock range of the Orange Mountains and generally affords exceptional opportunities for splendid public parks.



## CEMETERY NOTES.

Jacob Klein, who, says the Carson City, Nev., *Appeal*, is a man of advanced ideas, is now arranging to build a crematory furnace in that city to *incendurate* the dead. This is a sudden advance!

\* \* \*

When paving is carried out by the town of Canton, Ill., on a certain street leading to the cemetery entrance, a public spirited citizen has offered to put up a \$1,000 entrance to the cemetery. Let the paving be done!

\* \* \*

The trustees of Elmwood cemetery, Detroit, Mich., have decided to build a public mausoleum with 190 crypts, to be the largest of the kind in the country and also different from all others, in respect to being underground. The entrance will be on the side of a hill.

\* \* \*

Lakeview Cemetery, Bridgeport, Conn., is being improved by a new entrance and other works. Mr. B. F. Hathaway, of Stamford, has been engaged to lay out and supervise the improvement of a further 16 acres of the grounds. The cemetery now comprises over 35 acres.

\* \* \*

According to a Russian story: A young widow put up a costly monument to her late husband, and inscribed upon it: "My grief is so great that I cannot bear it." A year or so later, however, she married again, and, feeling a little awkwardness about the inscription, she solved the difficulty by adding one word to it, "Alone."

\* \* \*

The Electric Railroad Co. of Kansas City, Mo., is extending its lines so as to reach Mount Muncie Cemetery. This will be a great boon to the poorer classes. It proposes to run regular funeral trains to the cemetery and a design for a funeral car has been prepared. When the car reaches the gates of the cemetery the casket will be carried to a car having pneumatic wheels by the pall bearers and taken to the grave. In the city the remains will be conveyed in a hearse to the railway station.

\* \* \*

The burial ground adjoining the Congregational Church in West Haven, Conn., contains some old grave stones, many of the legible dates being as early as 1711. In this ground there are several marked with dates thus: 1745-6, 1738-9, etc., which is explained by the fact of the uncertainty which prevailed in the Puritan time concerning the beginning of the year, which was variously given to several months in different countries. The Greek custom of burial with the head to the west is fully carried out in this old burial plot.

\* \* \*

A fine mausoleum is to be erected in Bellefontaine Cemetery, St. Louis, Mo., by Mr. Samuel Cupples in memory of his wife. It will be 25 feet long, 17 feet wide and 25 feet high, and be constructed of Barre granite. The architecture will be of the Greek order. The ornate interior will be of Italian marble. It will contain 12 crypts. At the far end a group of statuary of three figures will represent three departed children. There will be a handsome stained glass window on each side; the floor will be tessellated marble and the doors of bronze.

\* \* \*

At Uagadah, in Upper Egypt, Mr. Petrie has discovered a curious and very ancient cemetery. The people buried there are not Egyptians, for their bodies are systematically mutilated; the heads are taken off and buried after the bodies, and the larger bones are broken off at the narrow end and gnawed. The articles found belong to the latest stone age; there are stone and alabaster vases, beads, beautifully worked flints, ivory and bone hairpins and combs, and a great variety of pots, many of them

decorated, but no iron or bronze. Some papyri have also been found, one of which for the first time gives the complete list of the first ten Ptolemies in Greek.

\* \* \*

Maple Grove Cemetery, Wichita, Kas., has distributed a leaflet of extracts from its By-laws and Rules and Regulations, with many good suggestions to lot owners. It suggests in one instance, that occasional summer houses, seats or fountains with handsome tablet and inscription to the memory of the dead, are far more appreciative monuments than the many common and costly stones. It is also hoped to see at some time a memorial chapel erected in the grounds where funeral services can be held in bad weather, and far better than in crowded houses. Such things should be provided for by will. It closes with a recommendation to its lot owners to subscribe to this Journal as its pages contain much useful information and valuable suggestions.

\* \* \*

The annual meeting of the Rural Cemetery Co. of St. John, N. B., shows a marked advance in cemetery ideas. The president in his report to the proprietors dilated upon the modern cemetery, its necessities and government, paid a tribute to the cemeteries of the United States, and made a strong appeal for perpetual care of lots, a matter that has already made a fair start. In support of these progressive intentions, new by-laws had been enacted, based upon the best practice of American cemeteries, and although the gross receipts of the cemetery are comparatively small, a great deal had been accomplished. This association is taking active steps in the improvement of its property. Its superintendent was sent last year to the annual convention of cemetery superintendents at Philadelphia, and made visits to prominent cemeteries to gather information. The local press has been wisely induced to take interest in its affairs and the coming summer will witness further progress.

\* \* \*

At the annual meeting of the Marion Cemetery Association, Marion, O., total receipts from April 1, 1894, to April 1, 1895, \$8,071.41 were reported with expenditures of \$3,631.62. Of these lots were sold to amount of \$2,147.51 and lot endowments were \$2,941.99. There was a gain of \$4,439.79 in available assets during the year. In every way satisfactory conditions were reported. Resolutions in opposition to Sunday funerals and expensive funerals were adopted. Marion is a city of 10,000 inhabitants, and the above report shows what can be accomplished where the people are disposed to back up their cemetery management, and also where the officers devote themselves to the work. Long tenure of office has also been of great advantage here. Mr. P. O. Sharpless, one of the trustees, has held office for 30 years, and the other officers range with long records behind him. Enlargement of greenhouse and extensive planting of flowering shrubs and ornamental trees are now in progress. In a former issue we gave some views of this beautiful cemetery.

\* \* \*

The organization of a new cemetery association at Quincy, Ill., with the design of purchasing 175 acres of land, found itself confronted with a law passed in 1891, by the legislature of Illinois, limiting the quantity of land that could be used by cemetery companies or organizations to twenty acres. This law was of the class of special legislation and with an object in view was rushed through in the year named. An amendment was necessary to remove the obstacle, so a bill was introduced February 13 last to remove the 20 acre limitation, entitled: "A bill for an act to amend Section 1 of an act in relation to cemeteries." The section amended now reads as follows:

Section 1. That all cemetery associations, or companies incorporated for cemetery purposes, by any general or special law of this state, may acquire by purchase, gift or demise, and may hold, own and convey for burial purposes only, so much land as



may be necessary for use as a cemetery or burial place for the dead.

Section 2. Whereas an emergency exists, therefore this act shall take effect and be in force from and after its passage.

The bill was promptly signed by the governor, and the new Quincy cemetery association can proceed with its work.

\* \* \*

Mr. John G. Barker, Superintendent of Forest Hills Cemetery, Boston, Mass., has been invited by the Association of American Cemetery Superintendents to prepare a paper on "Greenhouses in Cemeteries," to be read at their next annual meeting in Richmond, Va. To make the paper of general value and to give all desirable information, he has sent the following circular of questions to all the members of the association, and will be glad also to hear from other superintendents not members of the association who will favor him with replies:

1. Have you any Greenhouse, or houses?
2. If so, give size of each house?
3. How do you heat them, with steam, hot water, or a brick flue; if steam or hot water, what boiler do you use?
4. What class of plants do you grow mostly, flowering or foliage, and how many do you plant out each season?
5. If you have no Greenhouses, do you think it desirable that you should; if so, please give your reasons?
6. Do you use hot beds or cold frames?

In answering, please refer to each question as follows:—  
Question 1-2-3-4-5-6.

## Correspondence.

### Lining Graves.

*Editor Park and Cemetery:*

DEAR SIR:—The use of grave linings, interdicted on sanitary grounds by the burial reform movement, has some features well worthy of consideration. There is no more sad or indeed gruesome sight than a sunken grave—nothing about a cemetery so dreary, so repellent as a caving sinking grave pit. For at least ten long years under the common method of burial will the surface continue to give way, letting down the grave mound now at this end now at that, a continuing pit in the lawn. And if not constantly attended to there will as the caving continues, come gaping crevices down along the grave walls, even more than suggestively leading directly to the burial itself. Now, a grave lining well placed will permit the soil above it to be closely and firmly packed beyond the peradventure of any further settling. The turf then laid on will keep its true surface or the mound remains as first formed. The lining is worth many times its cost for this one result alone.

Then as a matter of sanitation a grave thus arranged must be far more wholesome than one presenting constantly opening passages for the ready escape of gases to the surface.

There are other reasons of a sentimental nature that would in the minds of many be strong in favoring the use of a grave lining which provided at least a strong arching over, and clearing, the coffin or case, but the two above mentioned are enough of themselves if understood, to ensure the common use of such linings by all who could afford the expense.

Red Wing, Minn.

D. D.

\* \* \*

Marcus, Ia, March 19th, 1895.

*Editor Park and Cemetery.*

DEAR SIR:—We have a cemetery of 15 acres near the small country town of Marcus, Iowa. We have a diamond shaped driveway from end to end and one around the edge, but people bother us by driving all over the ground at time of funerals, not maliciously, but still cutting up the grass all the same. Do you think it practicable, or is it customary to exclude teams from the grounds? We wish to keep our grounds in good condition. Will you kindly refer to this matter in the paper when convenient, stating what is usually done in such cases.

Very truly yours, B. R.

It is not customary to exclude teams, in connection with funerals, from cemetery grounds; but in the usual by-laws, driveway over the lawns, or in any way trespassing outside the prescribed tracts is absolutely prohibited, and in some cemeteries where a driver is caught in such an act he is henceforth deprived from driving into the grounds.—(ED.)

## CEMETERY REPORTS.

The following information was given in the 47th report presented at the annual meeting of the Swan Point Cemetery Association, Providence, R. I.:

Interments during the year, including 37 for the receiving tomb, 247; removals from other cemeteries, 13; removals from the cemetery, 4; total number of interments to December 31, 1894, 13,198; brick and slate vaults built, 103; plain graves opened, 144; foundations to monuments and tablets built, 205; curbing removed from lots, 4; catch basins built, 27; land belonging to the cemetery graded, manured and laid down to grass, square feet, 152,460; land sold during the year, square feet, 13,548; number of lots put under perpetual care and upon which bequests have been made, 1307; number of lots under annual care, 627; number of lots under partial care, 220; number of lots not under care, 989; whole number of lots sold to date, 3,143.

A large amount of heavy work of improvement has been carried out, and the bowlder wall, one of the special features of the cemetery completed. The importation of a limited number of hardy rhododendrons, azaleas, etc., every spring, (rather than a larger quantity in any one year), has been a success, and no doubt Swan Point has more of these beautiful plants than any other cemetery in the country. Last fall over 12,000 hardy bulbs and roots were imported, and of these some 6,000 tulips were planted, many of which are a new variety in the neighborhood, coming in flower late, and will be in perfection about Decoration Day, when so many people visit the cemetery, and early flowers are not abundant.

The treasurer's report shows cash receipts, including a balance of \$5,803.13 left over from 1893, of \$84,559.53; and that cash payments amounted to \$79,179.50.

\* \* \*

The annual report of Forest Hills Cemetery, Boston, Mass., shows receipts from sales of lots and graves \$34,671; receiving tomb \$2,728, and total receipts including investments and other sources \$123,236.68. The disbursements for labor, pay roll \$43,401.80, and total, including improvement and construction work, salaries and investments \$92,282.39. The balance in the treasurer's hands, January 31, 1895, was \$30,954.20. The Permanent Care Fund is \$21,538.84. Perpetual Care Fund \$574,426.29. During the year the superintendent's house was enlarged and improved and a new building begun near the Canterbury St. entrance, besides decided improvements over the grounds. The total number of interments in the cemetery have been 27,949; total lots sold to Feb. 1, 1895, 4,474; total lots under perpetual care 2,862, which includes 55 old lots; total lots sold last year 94 and single graves 240. The average income on perpetual care invested funds on January 31, 1895, was 4.67 per cent.

\* \* \*

The annual report of the trustees of the Greenwood Cemetery, Brooklyn, N. Y., for 1894, gives the amount of General Fund for the improvement and permanent care of the cemetery as \$1,716,802.06, an increase of \$108,058.44 for the year. The Trust Fund for the special and permanent care of lots has been increased by \$26,598.50 and now amounts to \$402,257.41. Considerable improvement was carried out during the year. Of the old enclosures around lots altogether 230 have been removed and general satisfaction is expressed. The total receipts for the year were \$424,731.26, of which sales of lots, single graves and receiving tomb fees amounted to \$178,204.56. The amount charged to labor in the disbursements amounts to \$129,556.76. The average monthly number of men employed was 233. In the summer 34 horses are in use.

### Association of American Cemetery Superintendents.

O. C. SIMONDS, "GraceLand," Chicago, President.

G. W. CREESY, "Harmony Grove," Salem, Mass., Vice-President.

F. EURICH, Woodlawn, Toledo, O., Secretary and Treasurer

The Ninth Annual Convention will be held at Richmond, Va., September 18, 19, and 20, 1895. A number of interesting papers have been promised.



## Publisher's Department.

Park Commissioners and Cemetery trustees are requested to send us copies of their reports.

Photographs and descriptive sketches of interesting features in parks and cemeteries are solicited from our readers.

RECEIVED.

Annual Proceedings of Corporation of Allegheny Cemetery for 1892, '93, '94, with President's Report and Financial Statements.

Annual Report of the Board of Cemetery Commissioners, City of Cambridge, Mass., for the year ending Nov. 30, 1894.

Report of the Board of Trustees of the Greenwood Cemetery, Brooklyn, for the year 1894.

Twenty-seventh Annual Report of the Trustees of the Proprietors of Forest Hills Cemetery, Boston, Mass., 1894.

From Mr. Burrill Chaffee, Supt. Oakwood Cemetery, Syracuse, N. Y., a collection of half-tone prints of views from "Picturesque Oakwood." They comprise many fine examples of monumental work and views in the cemetery.

22nd. Annual Report of the Board of Trustees and list of members of the Fairmount Park Art Association.

Souvenir of works of Art contributed by the Fairmount Park Art Association to Fairmount Park, Philadelphia.

From Mr. Wm. S. Egerton: Special Report upon a System of Parks and connecting Parkways to the Park Commission of the City of Troy, N. Y.

Annual Report for 1894, of Treasurer and Superintendent to the Commissioners of Washington Park, Albany, N. Y.

The Public Parks of the City of Albany, N. Y., by W. S. Egerton, Landscape Arch., etc., Supt. of Parks. A profusely illustrated and descriptive work on the parks of Albany.

Twenty-fifth Annual Report of the Buffalo, N. Y., Park Commissioners.

Miss Carrie F. Cochrane, daughter of Col. Cochrane, of Edgewood Cemetery, Nashua, N. H., writes: "Upon suggestion of my father I have made a little canvass among trustees and persons interested in cemetery improvement in our city, and now send you a list of fifteen subscribers for 'Park and Cemetery.' The list contains 11 trustees, 2 park commissioners, 2 cemetery superintendents, 1 funeral director and 1 monument dealer." Miss Cochrane's example is one, which

copied, would be highly beneficial to the publisher and we believe the subscriber, and is warmly appreciated.

The Dingee & Conard Co., of West Grove, Pa., whose advertisement appears on another page, and who claim to be the leading Rose Growers of America, are a reliable firm with a reputation of over twenty-five years' standing. They have a very extensive establishment and carry on a business all over the country, and it may be very positively stated that all entrusting them with an order are guaranteed satisfaction in every particular.

An illustration of the Dille & McGuire latest pattern Diamond High Grass Lawn Mower will be found in our advertising pages. More than one hundred of the Diamond Lawn Mowers were used on the grounds of the World's Fair at Chicago in 1892-93, where they gave excellent satisfaction. They are of simple construction, easy running and durable. The success of the "Diamond High Grass Mower" in cutting high grass is remarkable, and the clean cut shows conclusively that its working parts have been developed with great care in order to realize so permanent a position as a reliable machine. It is made in sizes from 14 to 20 in. cut and it is now in use in many cemeteries. The Dille & McGuire Mfg. Co., Richmond, Ind., the manufacturers, issue a handsomely illustrated souvenir pamphlet, in which the mower and its capabilities are most graphically displayed.

## Free to Parks and Cemeteries.

A Sample of the Best Lawn Sprayer made. Endorsed by Superintendents of Parks and Cemeteries of Chicago. Write for sample. State size of hose.

**YOUNG SPRAYER CO.,**  
10 Marine Bldg. Chicago.

**STEAM ROAD ROLLERS.**  
THE O. S. KELLY CO. + +  
Springfield, Ohio, U.S.A.

Handsome Illustrated Catalogue sent free on application.

## EVERGREENS and SHADE TREES.

... For Park, Cemetery and Lawn Planting.

✻ A LARGE ASSORTMENT. ✻

Lowest Prices. Any Quantity. Car lots a Specialty. Write me for prices and save money.

ADDRESS **GEO. C. HANFORD,**  
MAKANDA, JACKSON CO., ILLS.

**G. VAN TUBERGEN, JR. HAARLEM, HOLLAND.**  
CHOICE DUTCH BULBS AND ATTRACTIVE BULBOUS PLANTS  
CATALOGUES FREE.  
GABEL & CO. SOLE AGENTS. - BOX 920, NEW YORK.

**WE ARE HEADQUARTERS FOR**  
**ROSES, BULBS, PLANTS AND SEEDS**  
**TRY OUR UNRIVALED SETS,**  
DELIVERED AT YOUR POST OFFICE PREPAID.  
**OUR CATALOGUE OF 120 PAGES FREE TO ALL.**  
TRY AND BE PLEASED, WE GUARANTEE SATISFACTION.

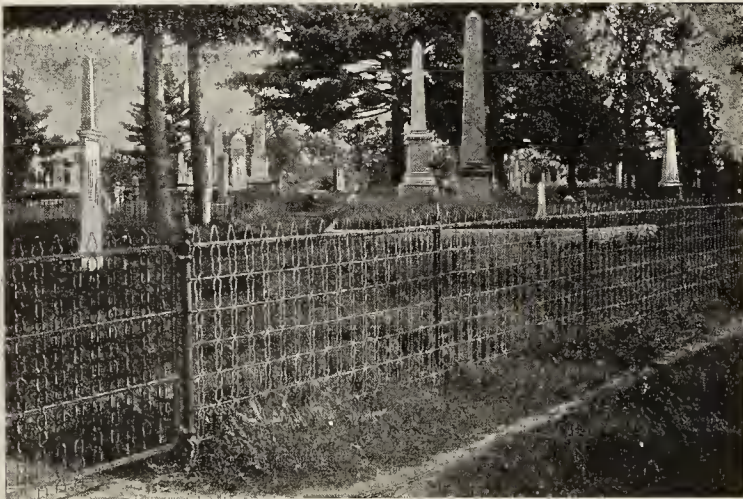
**50c. TRIAL SETS**

OUR SELECTION OF SORTS.

Set A.	10 Superb Everblooming Roses, 10 sorts.
Set B.	10 Prize Chrysanthemums in 10 sorts.
Set C.	10 Best Geraniums, 10 choicest colors.
Set D.	10 New Mammoth Verbenas, 10 colors.
Set E.	10 Sweetest Carnations, everblooming, 10 sorts.
Set F.	10 New Heliotropes, most fragrant, 10 sorts.
Set G.	10 Hardy Shrubs, leading sorts, 10 varieties.
Set H.	15 Gladioli, including Childs, 10 colors.
Set J.	3 Best Grapevine Sorts, all different colors.
Set K.	4 Select Sorts French Cannas, best bloomers.
Set L.	10 Vines and Creepers for Porch or Baskets.
Set M.	6 Ferns and Mosses for Ferneries.
Set N.	10 Foliage Plants, brightest, hardiest.
Set O.	15 Packets Choice Flower Seeds, select.
Set P.	2 Fine Graceful Palms, strong.

45th YEAR.  
4 ACRES UNDER GLASS.

Address **NANZ & NEUNER,** Louisville, Ky.

## HARTMAN STEEL PICKET FENCE.

Stronger than Iron.  
Cheaper than Wood.  
Handsome than either.

All Steel. One solid structure, bolted together and anchored, into the ground. Thousands of miles of it in use for Cemetery purposes and always approved.

Examine into the merits of this fence, before buying any sort. Get circular, catalogue and estimates from your dealer or

**HARTMAN MFG. CO.**

Gen'l Western Sales Agency, 601-602 Manhattan Bldg. Chicago.  
Gen'l Eastern Sales Agency, 277 Broadway, New York.  
Factories, Ellwood City, Pennn.



# PARK AND CEMETERY.

FORMERLY THE MODERN CEMETERY.

A Monthly Journal Devoted to Parks and Cemeteries.

R. J. HAIGHT, Publisher,  
334 Dearborn Street, CHICAGO.

Subscription \$1.00 a Year in Advance. Foreign Subscription \$1.25.

VOL. V. CHICAGO, MAY, 1895. No. 3.

## CONTENTS.

EDITORIAL—USEFUL MEMORIALS.....	37
PARK CONSTRUCTION.—CYCLING IN THE PARKS.....	38
*COLUMBIAN PARK, LAFAYETTE, IND.....	39
*THE HEMLOCK SPRUCE.—PERPETUAL CARE.....	40
*DELLWOOD CEMETERY, MANCHESTER, VT.....	42
THE SHORT PLANTING SEASON OF THE NORTH.....	43
*SHELTER HOUSE, CAVE HILL CEMETERY.—TREES.....	44
*STAG'S HORN FERN—GREENHOUSES—HOW TO BUILD V.....	45
COSTLY BURIAL GROUNDS AT FRANKLIN, MASS.—THE PROPOSED PARK SYSTEM OF TROY, N. Y.....	48
PRUNING TREES IN SUMMER TIME,—A TOWN CAN AC- CEPT A BEQUEST FOR IMPROVING CEMETERY. VALIDITY OF TESTAMENTARY WISHES AS TO BUR- IAL.—RIGHTS IN CEMETERY LOTS PURCHASED FOR FAMILY BURIAL PLACES.....	49
EARLY MOURNING CUSTOMS IN NEW ENGLAND.....	50
PARK NOTES.....	51
CEMETERY NOTES.....	52
CORRESPONDENCE—CEMETERY REPORTS.....	53
PUBLISHER'S DEPARTMENT.....	54

\*Illustrated.

### Useful Memorials.

In a previous issue attention was drawn to a class of memorials, which was especially suggested as highly appropriate, both for the purposes of commemorating the departed as well as the adornment of the cemetery. This idea is establishing itself and we note its recommendation in the printed matter of an existing cemetery. The proposed departure from cemetery custom is not so radical as it might appear at first sight. If the higher civilization recognizes the propriety of erecting hospitals, schools, libraries, museums, churches, fountains and structures, great and small, for the edification, enlightenment or recreation of man, as memorials to the dead in all kinds of public and private locations, why is it not even more appropriate to place useful and suitable memorial structures in our cemeteries for the same purpose. As a general thing the best of our cemeteries are woefully lacking in accommodations for the comfort of the lot owners and visitors. Little thought has been given to the fact that facilities for enjoying the beauties of these sacred spots enhance their value from a popular standpoint as well as create a broader interest in them. Take for instance the Shelter House, and in another column we give an illustration of one constructed in Cave

Hill Cemetery, Louisville, Ky. The season of cemetery beauty might be considerably prolonged for the lot owner, were it possible to enjoy its varied features, protected in some measure from seasonable discomforts.

Place a shelter house as a memorial to some departed one, in some favorable location, from which lovely vistas may open up, or where cool refreshing breezes blow, and it is morally certain that gratitude will mingle in no uncertain measure for the boon which has made quiet, restful enjoyment of the surroundings, possible. And there are many other features of cemetery adornment which might be made, equally appropriately, the subject of commemoration; such as Entrance Gates, Conservatories, Chapels, Receiving Vaults, Fountains, Bridges over water ways, Trees, etc. How much more gratifying to the living and to future generations, would such memorials be, than the costly and ostentatious piles of meaningless stone, often devoid of any artistic value.

In the proper carrying out of such ideas, the field of Art would be enlarged for the cemetery and additions made to its material welfare, which would in no small degree increase the confidence in its permanent existence. It is gratifying to observe that some cemetery officials are already alive to the importance of these suggestions and are drawing the attention of their lot owners to the subject. These recommendations should appeal to all cemetery officials, and the importance of taking active steps toward disseminating information and advice in this direction is apparent. The education of the lot owner means the continued welfare of the cemetery, and it is to the interests of the officials to exercise themselves to this end. Something more should be provided for the lot owner than the annual report. Every effort should be made to distribute the best and latest information on matters pertaining to the development and care of the properties. In these days, an idea, once recognized as of value, makes rapid progress, and alertness and work are necessary to keep up with the times.

THE foregoing suggestions on Useful Memorials are, in great measure, equally pertinent to the Park, and the idea presents opportunities to intending public benefactors well worthy of their consideration. Such benefactions appeal at once to public sentiment and tend to promote enduring gratitude.



### Park Construction.

In an instructive article on "Parks, Parkways and Pleasure Grounds" in *The Engineering Magazine*, Mr. F. Law Olmsted discusses the necessity and object of public pleasure grounds, their several types, the functions they fulfill and considers the subject under the heads of Government, Sites and Boundaries, General Plans or Designs and Construction, in the able way his large experience would promise. The following reprint on the subject of Park Construction gives some valuable suggestions:

"That the man who thinks out the general plan of a park ought to have daily supervision of the working-out of that plan is undoubtedly theoretically true. It is impossible to represent in drawings all the nice details in good work in grading and planting, and yet no work is more dependent for its effect upon finishing touches.

"On the other hand, however desirable the constant oversight of the landscape architect may be, it is impracticable under modern conditions. The education of a designer of parks consumes so much time, strength, and money that no existing American park commission, unless it be that of New York, can as yet afford to engage the whole time of a competent man. Consequently, it is the usual practice for the landscape architect to present his design in the form of a drawing or drawings, and to supplement the drawings by occasional visits for conference with those in immediate charge, by descriptive reports, and by correspondence.

"The prime requisite in the resident superintendent of park work is efficiency. Naturally enough, most of the superintendents of parks in the United States have been trained either as horticulturists or as engineers, but it is not necessary or even desirable that such should be the case. Probably the best results will be achieved by men who, possessing the organizing faculty and a realizing sense of the importance of their work, shall, with the assistance of an engineer and a plantsman, labor to execute faithful designs which they thoroughly understand and approve.

"Most men of specialized training, such as architects, engineers, and all grades of horticulturists, stand in need of an awakening before they are really competent to have to do with park work. Each has to learn that his building, his bridge or road, his tree or flower, which he has been accustomed to think of as an end in itself, is, in the park, only a means auxiliary and contributive to a larger end,—namely, the general landscape. It is hard for most gardeners to forego the use of plants which, however lovely or marvelous they may be as individuals, are only blots in landscape. It is hard for most engineers to conform their ideas of straightforward

construction to a due regard for appearance and the preservation of the charm of scenery. Neatness of finish in slopes adjacent to roads is not sufficient; such slopes must be contrived so as to avoid formality and all likeness to railroad cuts or fills. Road lines and grades which may be practicable in the ordinary world are to be avoided in the park, because the pleasure of the visitor is the one object held in view. Roads, walls, bridges, water-supply, drainage, and grading,—such of these works as may be necessary are to be executed with all technical skill, as in the outer world; but the engineer in charge should be a man who will see to it that the work is done with constant regard to the object of a park as distinguished from the object of a city street or square or railroad.

"Similarly, the park planter should be a man capable of holding fast to the idea that the value of a rural park consists in landscape, and not in gardening or the exhibition of specimen plants. Guided by this idea, he will avoid such absurd traces of formality as the too common practice of planting trees in rows beside curving driveways. In devising necessary plantations he will give preference to native plants, without avoiding exotics of kinds which blend easily. Thus, where a banana would be out of place, the equally foreign barberry, privet, or buckthorn may be admissible and useful. Influenced by the same principle, he will confine flower-gardening to the secluded garden, for which space may perhaps be found in some corner of the park.

"If men can be found who will thus co-operate with park commissioners to the end that the lands and landscapes which the latter hold in trust shall be cared for and made available in strict accordance with that trust, excellent results can be hoped for in American parks. As before remarked, men who are capable of such work may certainly be trusted to construct and manage town places—squares, playgrounds, and the like—with due regard to their special purposes and to the satisfaction of all concerned."

### Cycling in the Parks.

The wheel having become so popular a means of diversion as well as locomotion, it has become necessary to especially provide for its use in our public parks. In Prospect Park, Brooklyn, a cycling path has been established, and the following rules are in force in relation to wheel riding therein:

No person shall ride or operate a bicycle or tricycle on the park paths in Prospect park. Wheelmen walking upon park paths may push their wheels along the paths, but in no case shall the wheels be taken upon the turf.

Wheelmen must observe the law of the road, keeping to the





GENERAL DESIGN OF COLUMBIAN PARK, LAFAYETTE, IND.

right of the road and passing vehicles going in the same direction to the left wherever practicable. Coasting is forbidden. Wheelmen must keep their feet upon the pedals and have thorough control of the handle bars of their wheels at all times when riding. When riding at night wheelmen must have a lighted lamp on the front part of their machines.

Neither horses, carriages, wagons nor pedestrians shall be allowed on the bicycle pathway. Wheelmen dismounting on the bicycle pathway must remove their wheels from the graded surface to the turf until ready to remount.

No wheelmen shall ride at a rate of speed exceeding eight miles an hour in the park or ten miles an hour on the pathway or twelve miles an hour on the bicycle pathway between the park and Coney Island. Racing on the bicycle pathway is prohibited.

**Columbian Park, Lafayette, Ind.**

The illustration herewith represents a "Planting Plan," and general design for the improvement of Columbian Park, Lafayette, Ind., by Earnshaw & Punshon, landscape architects, Cincinnati, O.

The city reservoir is located in the park grounds, and one of the principal objects in the design was the transforming of the irregular excavations made to furnish the earth for the embankments of the reservoir into lakes of suitable outline, location and depth, so as to form a desirable feature in the development and ornamentation of the park, as well as to afford pleasant recreation in boating and skating.

An accurate topographical map showing contour lines and the location of existing trees, etc. was furnished by W. K. Eldridge, civil engineer, of Lafayette, from which was determined the proper locations of the lakes, buildings, avenues, etc. There were also prepared from the same map complete detailed grading and drainage plans for all the drives, walks and lawns. Although this illustration is intended to show the general appearance of the ground when fully improved, it more particularly indicates the location and kinds of trees, shrubs and evergreens necessary for shade and ornamentation.

The park grounds comprise about forty acres. Considerable work has already been done, in the way of grading and planting, and when they are completely improved in accordance with the design, the citizens will have a park easily accessible from all parts of the city, and which will provide various recreations at all seasons of the year. For this enjoyment they are indebted to the gratuitous services of the Board of Park Commissioners, of which Mr. A. Earl is president, who, fully appreciating the value of parks in the development of cities, and their influence in promoting the health, wealth and prosperity of all the inhabitants, have secured in the acquisition of Columbian park, an artistic and useful addition to the attractions of Lafayette.



**The Hemlock Spruce.**

TSUGA CANADENSIS.

It is rather strange that our native conifer, the hemlock spruce, is not more extensively used in ornamental planting. Its beauty should recommend it. The only way to account for its conspicuous absence is its being a native; a word which, when applied to trees, shrubs and plants, carries to many minds the idea of commonness.

In giving advice about evergreens, Mr. Falconer, I notice, says: "Among good-sized trees the American hemlock is the most elegant, but as it is so common," etc. He, of course, means common in the sense of being frequently seen. But the tree is seldom seen in Illinois, well grown specimens being really rare. Mr. Geo. Nicholson, Curator of the Royal Gardens, Kew, England, says: "the white pine and the hemlock spruce are pre-eminent among conifers." It is certainly the most graceful evergreen we have, and is beautiful when grown as an isolated specimen, and also when used as a hedge.

Mr. Elliott, the well known Landscape Artist, speaks of "the hemlock hedge which I think is the most beautiful and satisfactory one that can be grown in this climate," (Pittsburg,) and again, "for larger places I think our native hemlock spruce makes the handsomest of all hedges but," he adds, "it is much more difficult to establish," i. e., than the California privet. The difficulties of establishing it as a hedge would be less pronounced in the matter of specimen trees and even of groups, and as it is so beautiful and so satisfactory it is worth some trouble. Transplanted nursery stock would, however, give little or no trouble either as individual specimens or in hedges.

One of the most pleasing features of the planting in the Missouri Botanical Garden, formerly Shaw's Garden, is the double hedge row of hemlock spruces shown in the accompanying illustration. It is a picture the year around, and is such an excellent example of an unusual style of planting, unusual hereabouts, that I am glad to give some facts about it that were kindly furnished by Mr. Gurney, head gardener of the garden and Superintendent of Tower Grove Park, St. Louis, Mo.

He says in substance that the hedge rows were planted at the end of April, 1881. The stock used was transplanted in nursery rows two years before being set in their present location, and were two

feet high when planted in the hedge rows, where they were set five feet apart in the rows.

The soil, some sixteen inches in depth on a sub-soil of fire clay, was deeply dug and the little hemlocks were set on this, (no holes being dug,) and covered with soil hauled for the purpose. They have never been clipped, but have been pruned lightly each year at about the end of April, just when they started to grow. They are perfect hedges 80 feet in length, and are now each about six feet high and seven feet wide.

Mr. Gurney considers the hemlock spruce "the nearest approach we have, as an evergreen, to the lovely *Cedrus Deodara*." To what he says, I will add that the hedge rows are perfect models of beauty, and even so good a photograph as the one used herein cannot do them full justice.



THE HEMLOCK SPRUCE, MISSOURI BOTANICAL GARDEN, ST. LOUIS.

Graceful, fine in color and reliably hardy, the hemlock spruce should be more largely used. A long hedge of it would be delightful and not in summer only for, as Longfellow has said:

O hemlock tree! O hemlock tree!  
How faithful are thy branches!  
Green not alone in summer time,  
But in the winters' frost and rime!  
O hemlock tree! O hemlock tree!  
How faithful are thy branches.

*Fanny Copley Seavey.*

**Perpetual Care.**

By the perpetual care of cemetery lots is meant the cleaning off in spring time, cutting the grass during the summer and watering when necessary, in fact keeping the lots tidy. How can we change from the old method of conducting a cemetery to the modern and bring the place under the perpetual system, is a question frequently ask-



ed. All admit that the future care of a burial ground should be provided for, and not left to posterity. One correspondent writes: "I would like to bring my cemetery under the perpetual care system, but there are so many old lot owners who bought cheaply and have either looked after the lots themselves or paid a small sum each year for having their lot cared for." When this class of lot owners is approached and told the amount required to be funded and produce a sum sufficient to keep their ground in order, they exclaim, "why that is more than I gave for my lot," and they prefer joggling along in the old fashion. So how to make the change in this class of burial ground is a perplexing question. What is adaptable to one locality will probably not be suitable to another. Take for instance a cemetery in a large city, where the purchasing price of lots is from one to two dollars or more per square foot, and when the annual sales are heavy, ten or fifteen per cent taken from each sale will soon realize a large amount, the interest of which alone will rapidly help to swell the sum total. The perpetual care in such places is not in much doubt, no matter if nothing was set aside out of the purchase of the older lots. The fund will in a few years be large enough to care for the whole of the grounds. It is in the cemeteries in smaller communities that the problem is more difficult of solution. In several places appeals have been made to the lot owners, asking them to contribute to the future care fund and the response has been gratifying. The money thus obtained formed quite a nice "nest egg" with which to start the fund; but the number of owners willing and able to give is proportionately small. Frequently the original purchasers are among the departed or those who have moved away, and the heirs care little about the appearance of the family lot. These lots will always be a burden on the endowment. The general appearance of the grounds demand that such lots shall be attended to. One uncared for lot in the midst of those well cared for would militate against the appearance of the whole.

Let us take a burial ground where the prices range from 25 cts. to 50 cts. per foot and where the annual sales are small. Fifteen or twenty per cent deducted from such sales will not amount to much. The writer has in mind one such place, where after years of strict economy the trustees have accumulated seven thousand dollars, with the larger portion of the ground disposed of. The interest from the care fund is quite inadequate for the future maintenance of their grounds; they have therefore purchased more land on purpose to enlarge their cemetery and are anxious to start off upon a sufficiently good basis, to enable them to so increase

their care fund that in the future the whole place will be kept in decent order. In this instance the price of lots should be raised so that the amount deducted for the care fund will be adequate. They have been selling the land too cheaply in the past. It should be pointed out to intending purchasers that in taking a burial lot, they are not buying acreage property, but a piece of ground for a last resting place, the future care of which is as essential as the care of the dwellings of the living, yea, even more so, for the living will take care of themselves. But the dead are too soon forgotten, and if the future care of their resting place is not paid for in advance, the prospect is by no means bright for assurance of care in the future.

In some cemeteries the care fund is based upon the actual cost per foot for maintenance of each lot and frequently amounts to about one-fourth of the original purchase. In others an estimate is made of the amount which will be required to cut the grass and keep the roads in good order after there are no more for sale, putting away each year a certain amount of the profits, till the required end can be attained. In new cemeteries this is an excellent plan, and in one recently started the owners have decided not to declare any dividends till the endowment fund reaches the estimated point. They then can either allow the interest to accumulate or use it to improve the appearance of the grounds. In looking over the reports of the leading cemeteries, the price estimated as requisite for perpetual care varies considerably, and ranges all the way from 75 cents for small lots down to 20 cents per square foot for larger ones. A safe basis for small cemeteries would be to set aside an amount the interest from which would annually produce a sum equivalent to two cents per foot for small and a cent and a half for large lots.

Chicago.

*Bellett Lawson.*

At the recent meeting of the proprietors of the Lowell, Mass., Cemetery, the following rule was transferred to the By-Laws, which has the effect of giving to the lot owners themselves jurisdiction over its future:

"The corporation may hold in perpetual trust conveyances of the lots in the cemetery from lot-owners, subject to such conditions as may be therein expressed, not inconsistent with the conveyances to said lot-owners and statutes relating thereto."

The purpose of the by-law is to enable a lot-owner to prevent the possibility of any degenerate successor alienating the family burial lot, and thus avoid a complication of quite frequent occurrence.



## PARK AND CEMETERY.



ENTRANCE TO DELLWOOD CEMETERY, MANCHESTER, VT.

**Dellwood Cemetery, Manchester, Vermont.**

This cemetery was incorporated by act of legislature in 1865, and through the munificence of the late Mark Skinner and E. S. Isham, of Chicago, and others, has become one of the most beautiful of the smaller cemeteries of the country. "Dellwood" is



surrounded by mountains, the highest of which is 4000 feet. It is situated on a high elevation, almost the highest point on the highway for fifty miles. Its distance from New York City is about two hundred

miles, and it contains about twenty acres. It was originally laid out by the late Burton A. Thomas of Albany, N. Y.

The main avenue, commencing at the entrance, winds artistically over the more elevated ground to the valley beneath, eventually bringing one to its starting point at the entrance. There are also many smaller avenues or walks for pedestrians only and these are probably unsurpassed in the country, winding as they do under the thick spreading branches of Birch, Beech, Elm, Maple and Spruce, and in addition, being within the sound of the clear rippling brook of mountain spring water which runs through the entire length of the cemetery.

At either end of the grounds there is a beautiful sheet of water, clear as crystal, which has been artificially made by damming the stream. Floating on these miniature lakes in summer are Nymph-

æas in abundance throwing off their sweet fragrance to the passer by. The avenues and walks receive a good deal of attention and are made of fine white gravel, well packed. Flowering plants in summer are abundant in every part of the cemetery; here we find a border skirting one of the avenues, four hundred feet long and six feet wide, filled with flowering plants and shrubs; then again we are confronted with a large circle containing an immense vase filled with vines and bright flowering plants standing in the center of a well kept piece of lawn of emerald green; outside of this is a border eight feet wide containing flowering plants and bright foliage. Again we cross a bridge which spans the stream and arrive at the highest point in the cemetery, and lying before us is a large circular mound of beautiful lawn in the center of which is a twenty foot cross filled with double sweet Alys-



SCENE IN DELLWOOD CEMETERY.



sum. Many vases have been set in the private lots, —some lots have two.

Greenhouses are connected with the cemetery in which plants are grown for summer use, some 10,000 being required annually. The cemetery also displays some fine monuments, notably those of the late Mark Skinner and E. S. Isham. A fine



SUPERINTENDENT'S COTTAGE.

tomb has just been completed for Mrs. B. F. Carver and is built mainly of Hardwick granite.

The entrance was the gift of Mark Skinner. On either side of the gateway, standing on large pedestals are two figures representing "Death" and the "Resurrection;" these are of the finest Italian marble; back of these are two more pedestals surmounted by handsome vases in summer, while on the other two pedestals stand turned marble balls. The same gentleman also completed, just previous to his death, a very handsome stone cottage for the superintendent at a cost of \$8,000, besides leaving to the Cemetery Association \$10,000 to establish a fund. Dellwood has very few equals if any in the country for beauty and situation, and our city guests who are very numerous here through the summer greatly enjoy its natural and other beautiful attractions. What greater monument can any one have or desire than that of knowing he has by his means and influence, raised out of the old village grave yard, a living monument of beauty for the pleasure not only of the present generation, but of future generations? G. S.

#### The Short Planting Season of the North.

It is doubtful if the conditions of the Northern climate receive such consideration at the hands of Park Boards and Cemetery associations, as will enable them to properly arrange the work of planting without hurry and confusion.

The common practice is to respond to the call of Spring, and get a shout fever of energy for improvement about April, to be as suddenly postponed because the trees are in full leaf—and "it is too late."

The trained foresight of the gardener, [I don't mean a garden laborer, or any other person with a qualification] is essential to the successful management of large operations; they cannot successfully be delegated to a novice from a nursery, they cannot be tastefully and seasonably carried through by one person in a million. You will feel disposed to dispute the statement perhaps, but be sure you have looked the ground over well before you dispute at all. If you possess a critical taste you will perhaps be astonished to find how very few of the compositions in the wide world are worthy the attention of a landscape painter.

How far the mediocrity in landscape effect is due to hurry, how much is due to inherent want of taste, how much is due to a passion for bridges, tunnels, roads, and refectories, how much is due to sheer blindness, it is difficult to say—but this is certain, it is neither due to want of material, nor to climate, for Nature has lavished the one and given unseen prescience to combat the other. The great majority of men simply neglect to apply either. It doesn't pay them perhaps? then if they care for effect in Park or Garden, either for themselves or in trust for others let them secure the services of someone who has made it a business. The men you will have to select from will vary, and often enough the best men may be overlooked, and a mere plagiarist selected. All the eminent landscape gardeners of the world came to notice through the patronage of some one man of more than ordinary taste. The late Duke of Devonshire was responsible for two of the most eminent practitioners of the past generation.

The very first enquiry either one of these men would have made would have been as to the climatology of the region he operated in. It is very safe to say that neither Sir Joseph Paxton nor John Gibson ever ventured to use a plant before they had fully acquainted themselves with every climatological fact obtainable and connected with it. Oranges would have been impossibly hardy in northern Florida to the one, and Sweet Bays at Washington to the other.

Not only the degrees of cold, but their duration, as well as the duration of all the features which constitute a climate are considered by a thorough practitioner. When these facts are known he can tell to a nicety very often if special arrangements are necessary to facilitate success in planting.

It was my fate many years ago to reside in a climate where planting from the nursery could be done only during a single month of the year. The Forest Department was driven (or thought it was driven) to the use of flower pots. But by preparing every single item of the work before hand, by having all tools and utensils ready, all the holes dug,

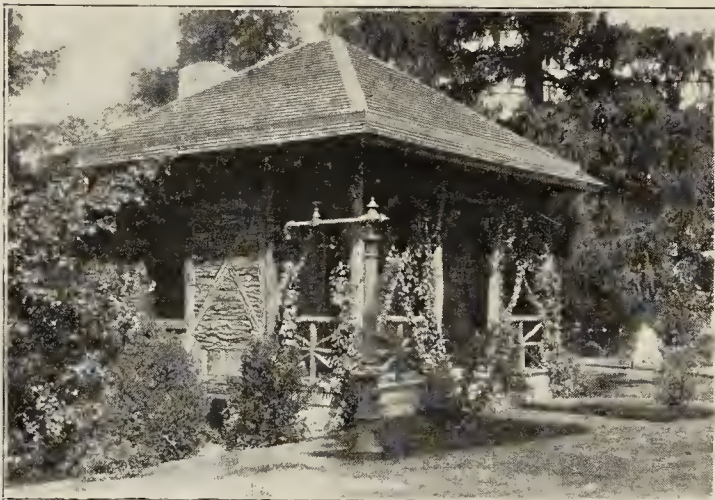


every plant on the ground, and the laborer ready at the word, no great difficulty was experienced, and the same facility offers right here in North America, providing of course that some farmer who does not know whether there are 100 species of plants in the vegetable kingdom or 150, undertakes to dictate the whole affair, and order the building of a fine big Gymnasium by "Jiminy Criky."

Trenton, N. J. *James McPherson.*

#### Shelter House, Cave Hill Cemetery, Louisville, Ky.

The accompanying illustration represents an attractive little shelter house, in Cave Hill Cemetery, Louisville, Ky. It is about eighteen feet square, and the same in height, constructed in the rustic style, and now handsomely decorated by honeysuckles and English Ivy. The exterior is covered with oak bark, laid the St. Andrews' cross pattern.



The porch is carried by six posts in the natural state. The interior is finished in hard wood. It is well lighted by large windows and is heated by an old style fire-place. The chimney is constructed of large rough limestone blocks. The toilet room is in the basement. The little building cost \$700, is an ornament to the grounds and is highly appreciated by the lot owners and visitors. To the left of the house is a magnificent specimen of *Salisburia Adiantifolia*, sixty feet high and some forty feet spread.

#### Trees.

The cultivation and study of trees very naturally and almost unavoidably, lead to contemplation and reflection. One can hardly imagine a more appropriate place for the exhibition of those beautiful wonders of nature, than the quiet and peaceful sanctuary of the dead. Every man who has the opportunity of planting a tree and avails himself not of it, waives the privilege which is thus given him of benefiting posterity. While men sleep trees

grow; and after adding, during their growth, to the beauty of the landscape, providing shade and shelter, they also ameliorate the climate and soil of their location. Judicious planting and the cultivation of the various kinds of forest trees, belong to the first branch of the economic art.

The arboriculturist, in particular, will find Spring Grove Cemetery a place of great interest. It has been the desire of the directory from the first to introduce a variety of suitable representatives of the vegetable kingdom into these grounds. In this they were considerably assisted by the lot-holders themselves, the most prominent of them being members of the Cincinnati Horticultural Society, which society originated the idea of establishing a rural cemetery in the vicinity of the "Queen City of the West."

The greater part of the grounds, when purchased, was, as stated before, densely covered with native forest trees. In the lower or southern portion, the elm, sycamore and ash predominate. The central part of the grounds is chiefly covered with tulip trees, sugar maple, sassafras, etc., while the western portion is almost exclusively occupied with beech, sour gum, redbud, and dogwood. The northern part is adorned with some of the finest groves of various kinds of oak, of nature's own planting centuries ago. The effect produced by the brilliant colors which most of these trees and shrubs assume in autumn, is truly magnificent.

The introduction of varieties of evergreens, whose perennial verdure is particularly appropriate for ornamenting places of sepulture, has contributed much to mitigate the bleak desolation of winter. The pine, the cedar, the cypress, the yew, and the ivy, are already embalmed in sepulchral literature.

There is, perhaps, no tribe of plants, not excepting even the oaks, which claim more admiration than the genus *pinus*, nor any that brings with it so many pleasing recollections or associations of thought. In the scriptures, which abound in sublime and beautiful allusions to the woods and forest scenery of Syria and Palestine, the various species of the pine tribe stand eminently conspicuous. In the forty-first chapter of Isaiah, Jehovah says: "I will plant in the wilderness the cedar,—I will set in the desert the fir tree and the pine." Several of the grand old cedars, which are believed to have been in their prime when Solomon built the temple, are still standing in a gorge on Mount Lebanon. The bark of the most ancient has, in many cases, been cut away to afford room for carving the names of Christian visitors. To protect from such wanton and stupid injury these biblical emblems of strength, is a work in which Protestant, Catholic, Jew, and Moslem should join.



The ancient Egyptian considered the pine as an emblem of the soul. The Roman poets also mention the pine frequently. Virgil alludes to the mournful sounds produced among the branches by the wind, and calls them singing pines.

"The pines of Mœnalus were heard to mourn,  
And sound of woe along the groves were borne."

Stattius says: "*sylvanum gloria pinus*," "the pine the glory of the woods." And again: "*hinc, audax abies, et odoro vulnere, pinus*," "the pine that breathes forth fragrance from each wound." In the Dendrographia of Johnston, groves of pine are said to be particularly wholesome to walk in; and every one must have felt the refreshing influence of such a walk in the beginning of summer, when the pines are producing their shoots, the resin at that time being in a comparatively volatilized state, and floating in the atmosphere.

This interesting family of plants now engages much of the attention of the most zealous and enterprising lovers of arboriculture. The introduction of numerous species of conifers from all parts of the world, into this vicinity of late years, and many extensive plantations, comprising some of the rarest species of arboreal vegetation, may be seen upon the adjoining heights of Clifton, as well as in our own grounds.

The varieties of situations and soil at Spring Grove, in which it may be desirable to plant the various kinds of trees and shrubs, are very numerous, and no treatise, however elaborate in detail, could bring the whole under review. From the practice of indiscriminate and capricious planting by those who own lots, a large number have had cause to regret some untoward results. Choice specimens of trees are often seen to injure each other by too close planting, and, in many instances, proprietors of lots obstinately refuse to permit the removal of some in order to save others, until it is too late. Rare and beautiful specimens are found hidden and destroyed by others of an inferior description, which should be removed.

The largest and best grown specimens of evergreens on these grounds are the following:

*Pinus Austriaca*, *Cembra*, *excelsa*, *larici*. *Mughus*, *pumilio*, *ponderosa*, *rubra*, *rigida*, *Strobus*, and *synvestris*. *Abies alba*, *nigra*, *rubra*, *Canadensis*, *excelsa*, *orientalis*, and *Douglassii*. *Picea balsamea*, *nobilis*, *Nordmanniana*, *Pichta*, *pectinata*, and *Pinsapo*. *Juniperus oblonga pendula*, *Suecica*, *Hibernica*, *Virginiana glauca*, and *Sabina*. *Thuja occidentalis*, *orientalis*, *tartarica*, *filiformis*, *aurea*, *Taxus baccata*, *Canadensis*, and others.

A large number of other rare evergreen trees and shrubs have been planted, but are yet small plants.

A. Strauch.

#### The Stags Horn Fern.

In the Fern House, Horticultural Hall, Fairmount Park, Philadelphia, there is such a fine Stag's Horn fern, *Platycerum Grande*, that an illustration has been made of it for this paper from a photograph direct from the original. This very singular looking fern is one of the attractions of the house. It is planted on a decayed tree fern



stump, and the way it has flourished shows how well it is suited. How well its common name fits it will be instantly recognized. The vine which embraces the stump to such good advantage is the creeping fig, *Ficus Repens*, and it certainly assists in making a pretty picture. A few of the fern, *Nephrolepis Exallata*, have found a home with the fig, and other ferns spring out spontaneously from among the fig branches at times.

The use of the vine to cover the decayed trunk illustrates what can be done in this way both indoors and out. What would be an unsightly object is made beautiful when covered with vines. In this case, the stump, vine and fern combined, make a very pretty object.

Germantown, Pa.

Joseph Mechan,

#### Greenhouses.—How to Build. V.

The posts must be carefully peeled; if round must be flattened and trued on the side which receives the sheathing. The lower ends are sometimes charred, and sometimes tarred up to a few inches above ground in order to preserve them. A much better way is to soak the whole post in crude pe-



troleum or fuel oil. If the oil is too thick it can be thinned with a little kerosene. The writer has in a greenhouse, common hemlock posts treated in this manner, which after five years show no signs of decay. Crude oil will be found of value if applied to lot and grave stakes, and it makes an excellent paint for woodwork anywhere that the color is not objectionable. It is a better preservative than lead paint and the cost is very small. The odor soon disappears. All inside parts of the greenhouses *below the gutter bottoms* and both sides of the shiplap should be well coated with

flattened side of the post covering its upper four feet, the plumb can be readily applied to its side and edge, thus plumbing the post.

The two end posts are first set, then a line is stretched near the ground from the face side of one to that of the other. Each post can be then brought to this line, the board tacked on and plumbed, being careful to keep the posts properly spaced.

The brackets "B" should have been previously cut, one for each post, from 2 by 6 inch soft pine as sound and free from sap and knots, as possible, and thoroughly soaked in the crude oil after being cut. The length of their lower sides will be 6 inches and of the upper will depend on the width of gutter, for the 10 inch (in the clear) gutter, as shown in the cut, this length will be about 10 inches. When adding another house the sill 6 is removed and replaced by a gutter sill, like 1, the upper part of the sheathing is removed and other brackets put on to carry this part of the gutter. Until that time it can be safely allowed to overhang as shown.

A saw cut is then made across the north side of the post to form a shoulder for the lower side of the bracket to rest upon. If the height of the upper point of the sill (1) is taken at 4 ft. 6 inches above the ground (G), the upper edge of the bracket must be about 4½ inches lower. The upper part of the post above the cut is then flattened, thoroughly covered with the oil and the bracket solidly spiked or lag-screwed in place, keeping the upper edge perfectly level and the square end out to the line of sheathing. Another bracket is then put on the south side of the north post. Lines are then carefully stretched, connecting the two ends of the upper edge of these brackets, as guides for setting the other brackets on the north sides of the intermediate posts. Great care must be used to put the tops perfectly level and the tops and square ends of all in a perfectly true line.

The projecting parts of the posts above the brackets are then to be sawed off with a downward bevel of about 1 inch so that the moisture will be carried away from the joint between bracket and post.

The gutter bottom (3) is then to be set. The gutter bottoms (3), sills (1), sash bars (2), plates and ridges, the whole roof in fact, must be of the very best of material. There is but little doubt that absolutely clear and sound white pine with no trace of sap is the best material to use. This has become so scarce and expensive that cypress has come into general use. If *live cut* this wood is very durable and answers the purpose well. It is however inclined to check and warp and shrinks and swells badly. It should not be used for the south end

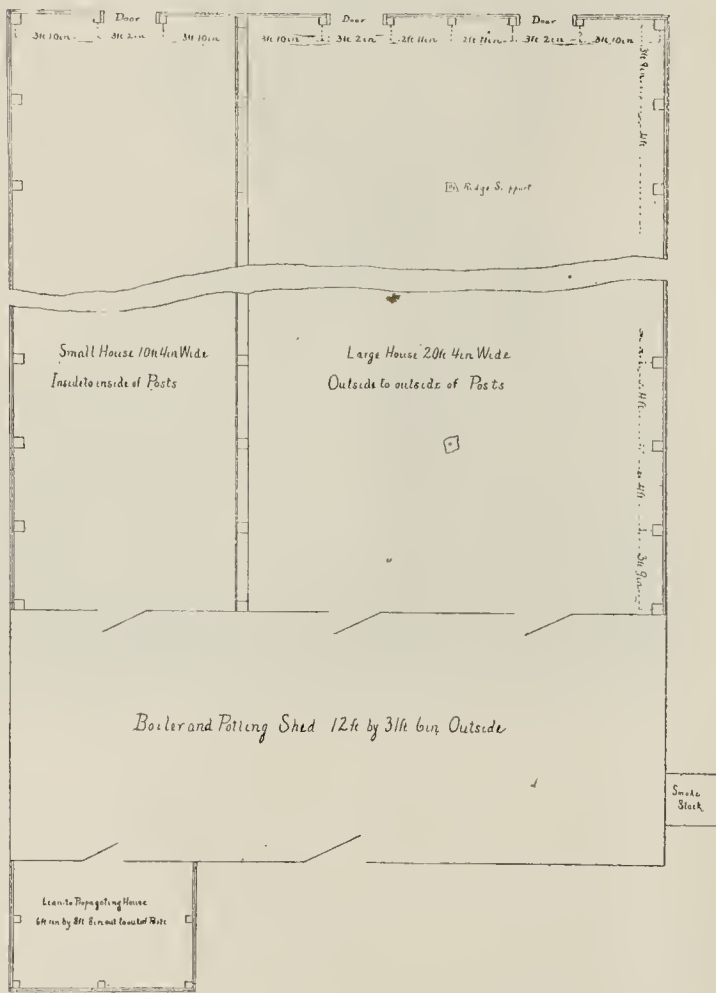


FIG. 5.\*

it. It should not, however, be used on the roof, gutters, bars or plates.

Figure 7 shows in cross section the outer wall with gutter. The post P is first sawed off square or nearly so at the bottom and then soaked in the oil as described before. After the hole is dug to the proper depth it is well rammed at the bottom. The post is then put in with the faced side toward the sheathing and well bedded by striking on the top with a heavy maul. The hole is then gradually filled up, ramming the earth in solidly, keeping it plumb. If a six inch board four feet long is dressed true on the edges and side, and tacked to the

\*This figure should have taken the place of the Fig. 5, given in last issue, which was marked in error Fig. 5, instead of Fig. 6.



doors, and the jambs will be best made from pine also. California red cedar is now offered by some firms and would appear to be well adapted at least for sash bars.

The mill work should be bought with the understanding that every piece be perfect, sound, clear and free from sap. It should be carefully inspected, piece by piece, and any piece having the slightest defect, peremptorily rejected. The poorest piece used determines the durability of the whole structure. Good cypress is heavy and quite hard. Any pieces that are very light will decay quickly.

All mill work should have been well primed with a coat of pure boiled linseed oil (there is much adulterated oil in the market) with a little genuine white lead. No lead should be bought except such as bears the name of some well known manufacturer with his guarantee that it is strictly pure.

The gutter bottom will be furnished cut to lengths and "halved" together, of  $1\frac{3}{4}$  inch stuff. It is shown 12 inches wide in the cut, making the gutter 10 inches wide. Narrower bottoms are often used but are not desirable. In time of heavy snow it is often necessary to walk in the gutter and shovel the snow out. It is difficult to work in a gutter less than 10 inches wide.

The bottom is laid on the brackets each piece in proper order. The joints are thickly coated with lead and oil mixed very thick. They are then brought together, accurately adjusted and fastened together by strong screws from above and below or by wrought nails carefully clinched, the heads well countersunk to receive putty. This must be very carefully and securely done. We now have the bottom in a continuous strip the length of the house and lying on the brackets. It must be pushed north until the end is firmly against the shed. The edge of the sheathing groove must be brought exactly to the square end of the bracket, as shown in the cut, and the bottom screwed firmly to the bracket with 4 heavy  $3\frac{1}{2}$  or 4 inch screws, heads countersunk. It is then successively screwed to each bracket south, carefully straightening and adjusting the bot-

tom. The edge and top covered by sill (1) is then smeared with the thick lead, also the corresponding parts of the sill, it having been first fastened together lengthwise as was the sill. Beginning at the north end it is fastened by strong screws or, better, by lag screws and washers screwed through into the edge of the bottom, being careful to bring the shoulder down snug to the top of the gutter bottom and to screw the sill well up against the bottom. The other sill (6) can now be applied in a similar way but need not be so firmly done because it carries no weight. No. 1 should have lag screws through it not less than 18 inches and better 12 inches apart.

The upper piece of ship lap has the tongue dressed off and is then put in place, followed by the lower ones. This is well painted with crude oil both sides and at least one thickness of building paper put on outside, then the siding is applied.

Chicago.

*Willis N. Rudd.*

*(To be continued.)*

#### Monotony in Gardens.

The following from an article in the *Field* of London, contains some good points:

Perhaps the most grievous source of wasted effort in gardens is monotony arising from everybody growing what his neighbor grows, so that we lose many chances of variety. Thus it comes that the nurseryman who grows new or rare trees or shrubs often finds them left on his hands, so that many country nurseries only grow a few stereotyped things, which means monotony to gardens. The temptation is strong on the part of trade growers to keep only things that people want to grow freely, and to recommend things, which are without beauty, and offensive in odor when in flower. The presence of such things is one of the causes of the miserable aspect of the shrubberies in many gardens, which might be very beautiful with varied life. The presence of many shrubs of little beauty often destroys by their vigor rare and beautiful garden vegetation. And this nursery rubbish having eaten up every good thing begins to eat up itself, and hence we see so many shrubberies worn out. Lovers of the garden could do something to check this fatal tendency to monotony by taking up some family of plants for themselves which perhaps they are unable to find in the nursery gardens near. But the fact remains that even nurseries devoted to special subjects may be too exclusive. We say so much to show that even in the branches of gardening that seem best known there are neglected sources of interest, while among little-known plants there are many.

Specialists, such as rose growers, will often exclude good things from their collection.

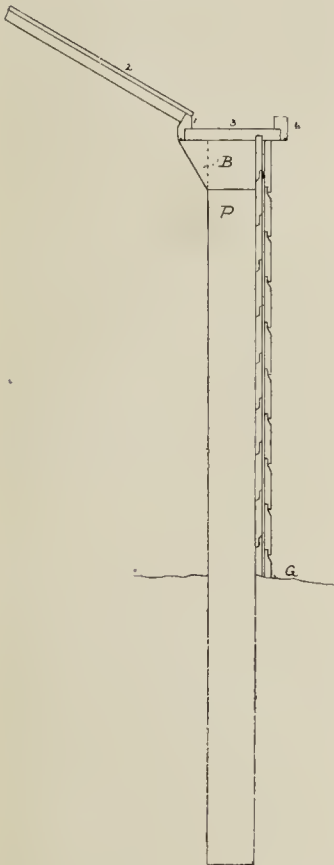


FIG. 7.



#### Costly Burial Grounds at Franklin, Mass.

The work upon the Ray family burial plat which was abandoned early last fall, owing to the severe weather, has been resumed.

This will be a most attractive private burial ground, and is being executed under the direction of Messrs. Gray and Blaisdell, landscape architects of Boston. This lot which contains about an acre, adjoins the old town cemetery on the south-west, and is a gently rolling tract. Upon its principal summit the main or family plat is situated, which is elliptical in form, eighty feet by one hundred feet, raised slightly above the winding drives leading to it, and divided by broad walks into four plats for the various branches of the family, each approach having broad platforms and easy steps, with simple buttresses and bases, which will carry large bronze urns for the reception of tropical plants.

An encircling path surrounds a central grass plat which contains an attractive monument of elliptical design and fine proportions. The lot will also contain areas for other families;—the whole arranged upon the lawn plan, with appropriate and attractive plantings.

The main entrances from Central Street to these grounds will be by a walled entrance; the walls being semi-elliptic in plan with carriage gateway, and two narrower side gates; these walls are to be built of seam faced granite, selected for its varied shading, with base and capping of finely cut Milford granite. The gates of wrought iron in chaste design will be supported by massive masonry posts; the whole forming an ornamental feature and a most attractive approach to the grounds.

In furtherance of the suggestions of the landscape architects, the selectmen of the town have petitioned the Massachusetts legislature for the privilege of taking a few feet from the cemetery for the purpose of improving Central Street along the cemetery grounds.

The entire work will be executed in a substantial and attractive manner at a cost of about \$25,000 and will be supplied with a fund to keep the whole in order.

#### The Proposed Park System of Troy, N. Y.

With a population of some 65,000, the city of Troy has no public recreation grounds worthy of the name of park, and an initiatory movement looking to a permanent scheme of such improvement in keeping with the needs and desires of the citizens was not taken until October, 1894. Mr. Wm. S. Egerton, landscape architect, was then engaged to report upon a park scheme, and the report was rendered in February last.

After a careful personal examination of all the available territory within and without the present city limits, Mr. Egerton settled upon two localities which he deemed to possess the desirable features for the construction of two parks of ample area, one to be situated in the northern and one in the southern portions of the city, both to be connected by a broad and attractive parkway. The map furnished outlined a sufficient area in both locations to secure desirable topographical features and to afford proper approaches.

Speaking of the boundaries of urban parks the report states: "No desirable features in the design of an urban park can be more strongly insisted upon than this: *That such area should be bounded by public thoroughfares and not by private properties.* This regulates and defines the rights of the bordering properties and relieves the authorities from endless demands of one kind and another.

The properties suggested to be acquired for the purpose are largely farming lands and there are no constructions of material value within the limits.

This north park when improved will afford some delightful views, of far reaching extent, as well as embrace within itself a variety of park landscape, including considerable water area of diversified shore line. The area included in the design of the North Park is close upon 270 acres.

A very picturesque site is that selected for the South Park, a valley with a running stream, widening into several lakes, and affording splendid opportunities for effective treatment, which the sketch map indicates has been taken advantage of. The irregular outline of the lakes and the meandering stream, running lengthwise through the property creates a diversity of feature which directly enhances the attractiveness of the site.

For park purposes, from a financial standpoint, this property is desirable in that it would involve immense expense to prepare it for purposes of investment, and therefore its cost should be reasonable.

The estimated possible cost per acre for the North Park, not including land, and depending upon the topography and character of surface treatment, would not be less than \$500 and in some portions might amount to \$1,000. For the South Park, with the treatment suggested, an expenditure of probably less than \$500 per acre would suffice.

The report ably discusses the advantages of parks to the community both upon ethical and business grounds, and urges upon the citizens of Troy to embrace the inviting opportunities now before them to secure such desirable and beneficial public improvements.



**Pruning Trees in Summer Time.**

The reader will remember what has been said about the pruning of trees during the winter months; but if a tree be properly pruned during the summer season, there is really very little for winter pruning to accomplish. It is the strong vigorous growth of trees that takes the nourishment away from the weaker growth. In ordinary garden language "strong shoots or sprouts on trees are robbers," and they should be pinched back or pulled off; the vigor of the tree is then thrown into the weaker shoots. In this way, any part of a tree that is naturally weak, can be made strong.

This point can be illustrated by the way in which street trees are trimmed. They are usually cut in the winter time, the chief reason being that at that time there is little work for men to do, and it is natural to recommend, as the best time, that in which they can find employment; but it must be within the experience of everyone, that the branches shoot out all the stronger at the point where the tops are cut away, by reason of the cutting away of these tops, and the lower branches that we wish to strengthen become still weaker. This must be frequently experienced, but if after a tree has been trimmed, in winter, in the manner referred to, these strong sprouts, which in summer follow the cutting, were pulled out after they had grown a few inches, the sap would then be thrown into the lower branches. In this way the winter pruning would not be so injurious; on the contrary, it might in many cases bring about what is so much desired, namely, a strengthening of the lower shoots. This summer pruning is especially effective with coniferous trees. In the case of pines, we know that in the spring time three or four branches push out at the end of last year's shoots, looking like gas burners. The central one is very vigorous and those on the sides are weaker. If we pinch out the point of the stronger one, the sap at once flows into the weaker ones, and they become strong, and new buds form at the place where the strong one was pinched off, next year this bud continues the growth of the branch almost as straight as if it had never been pinched back. We can pinch off the terminal bud of the main stem, a new bud forming a leader without any bend. One who understands this business of summer pruning an evergreen can so manage that the tree forms an absolutely perfect specimen from the ground to the top, no one branch being stronger than the other. The chief thing to remember is that in summer pruning the weak branches of the shoot should not be touched, it is only the stronger ones that require checking.—*Mechan's Monthly for May.*

**A Town can Accept a Bequest for Improving Cemetery.**

A cemetery may be kept in repair and in proper order, the supreme court of Vermont says by cultivating flowers, improving and beautifying lots and the cemetery, and fencing the cemetery. Furthermore, a town having power to raise money for such purposes, the court holds that it may accept a gift, the interest of which is required to be expended annually,—one-half in cultivating flowers on the donor's burial lot in the cemetery, improving and beautifying it, the other half in fencing, improving and beautifying the cemetery, even if the gift is coupled with the condition to keep the principal sum intact or good through all coming time, and a vote of the town accepting the bequest will bind it to the performance of the conditions.

**Validity of Testamentary Wishes as to Burial.**

The surrogate of Erie County, New York, holds valid a condition imposed in a will by the maker thereof, to be buried in a certain cemetery and making a bequest to her husband dependent upon his not preventing or opposing the execution of the will. What makes this decision the more important is the fact that the surrogate holds that the husband forfeited his legacies when he failed to comply with the direction of the testatrix in relation to her burial, he having been informed of the contents of the will on the afternoon or evening of the day of her death, though this information came to him after he had bought a lot in another cemetery, purchased the coffin, and engaged the undertaker, yet having ample opportunity to comply with her wishes had he so desired. The surrogate says that many cases have come under his observation where testamentary disposition has been made by a testator in relation to his funeral and burial, and it has been the universal custom, so far as his experience extends, to recognize such a right in the testator. The present state of society demands that courts should compel the performance of all reasonable directions made by a person in his will relating to his funeral and interment. If a person desires to pass from this earthly sphere through the legal process of cremation, he should have his testamentary wish effectuated by the court.

**Rights in Cemetery Lots Purchased for Family Burial Places.**

The supreme court of Pennsylvania has decided several very interesting points in affirming the decision of the court of common pleas of Allegheny county in the case of Lewis O. Walker. A cemetery lot was jointly purchased by four brothers, manifestly as a burial place for their family. A monument was erected, at the joint expense, in the



center of the lot, the four sides facing the four corners, and each inscribed with the name of one of the brothers. The corner space opposite the name was set apart as a burial place for that family. The father and mother were buried at the two opposite corners of the monument, thus placing them partly in each of the four divisions. The arrangement, it was held, did not make an oral partition of the lot; did not affect the title or uses for which the lot was purchased and dedicated, but the title still remained in the four brothers as the joint owners of the entire lot. Now while the owner of a burial lot may doubtless permit the interment of any relative, or even a stranger, in his lot, in the case of two or more joint owners, no one has that right, but it requires the consent of all. Consequently, in this case one of the brothers, or his widow, had no right to authorize the interment in that brother's portion of the common lot of any person not a member of his family, without the consent of the other joint owners. Still burials by such widow of her mother and her sister would, after eighteen or more years, it was held, be inferred to have been consented to, and no objection would be permitted to be raised. A recent purchaser by quit-claim from the widow and heirs of one of the brothers was enjoined from future interments in the lot, or erecting any tombstone or otherwise interfering with the lot, without the consent of the other joint owners, and was required to remove bodies but a few years since interred, and all tombstones erected by such purchaser. The defacement of a monument by simply cutting off the raised letters on one side thereof by the purchaser of such an interest as that last mentioned, it was said was hardly such a defacement as required a new monument.

#### Early Mourning Customs in New England.

In a paper on "Customs of Mourning," recently read by Mrs. C. E. Bigelow, before a Woman's Club, she gave the following on the customs in vogue in early times in our own New England:

"In Hartford and neighboring towns all ornaments, mirrors, and pictures were muffled. Window shutters were closed in front and kept tied with black for a year. Gloves were sent as an approved form of invitation to a General. In 1736 at the funeral of Gov. Bilcher's wife more than 1,000 pairs of gloves were thus given away. And at the funeral of Andrew Fanieul more than 3,000 pairs. The Rev. Mr. Elliott of the North Church in Boston kept a record of gloves he thus received, and in thirty-two years he was given 2,940 pairs. In these later years and in this practical generation, people do not look to others to find their belief or hope, or even an expression of their sorrow in the

shade or shape of their garments. The bonds of custom are strong, but they are not too strong for common sense and conscience to break asunder. And if all had independence of thought and action, no fashion could be ever dictatorial. And when we can have more inspiring examples of those who have the moral courage to stem the tide of foolish custom, we can hope the day is not far distant when enlightened common sense shall rule in these matters.

In this matter of Funeral Reform, the Rev. E. M. Milligan, of Steubenville, Ohio, in the course of a recent sermon said: "Fashion regulates everything, and there is a tendency at funerals to impose a burden on the living poor, merely in deference to prevailing customs.

"Funerals should not be set for the Sabbath Day by Christians. It is only done in order to have a big turnout, but it is a desecration of God's day. Funeral services should be held in the evening of a week day at the convenience of friends. This will give a chance for private leave taking and prevent hysterical scenes at funerals. It will also stop the expensive hiring of carriages for people who only go to have a carriage ride. Leave these people to hire a carriage, and then you will see how deep their sympathy is. Emblems of mourning should be discouraged. They are not authorized by the scriptures."



RIETCHEL'S STATUE OF SCHILLER AND GOETHE AT WEIMAR, A FACSIMILE OF WHICH IT IS PROPOSED TO ERECT IN GOLDEN GATE PARK, SAN FRANCISCO.



◁ PARK NOTES. ▷

Glens Falls, N. Y., has no public park but is agitating the question.

\* \* \*

Wilmington, Delaware, is authorized to borrow \$50,000 for park improvements.

\* \* \*

Peabody, Mass., is the fortunate recipient of gifts of land for park purposes from the Misses Walker and Miss Proctor.

\* \* \*

The total expense of maintaining Lincoln park, Chicago, for the year ending March 31st, amounted to \$185,672. Permanent improvements cost \$45,000. The revenues for the present year will amount to \$246,659.

\* \* \*

The deaf and dumb citizens of Illinois have offered to present to Lincoln Park, Chicago, a duplicate of Daniel French's statue of Thomas H. Gallaudet instructing the deaf and dumb girl, now in Washington.

\* \* \*

By special act of the legislature of the state of New York, the common council of the City of Newburgh is authorized to borrow \$10,000 more, by the sale of twenty-year bonds, to continue work on "Downing Park."

\* \* \*

The Metropolitan park system of Boston comprises thirty-seven cities and towns. The commission appointed to apportion the cost to these towns reports an actual cash expenditure up to April 1st, on account of the Park Act, of \$746,500.87, and on account of Boulevard Act, \$35,321.86.

\* \* \*

The manager's report of the City Park Association of Philadelphia, shows that twenty-eight plots of ground have been designated by ordinances for park purposes since 1888. The action of the board of education is commended for opening school yards in the crowded districts of the city in midsummer.

\* \* \*

The Queen Victoria Niagara Falls Park Commission has taken formal possession of the tract of land at Queenston Heights, turned over to it by the Dominion Government. On this tract stands the well known Brock's monument, and some magnificent views are here to be obtained. Electric cars run to this new addition to the Niagara Falls Park system, and when proposed improvements are carried out, it will be an attractive spot, and the journey to it a delightful one.

\* \* \*

A Liberty tree was planted last month in Golden Gate Park, by Sequoia Chapter, Daughters of the American Revolution. The soil placed around the roots of the tree was collected from more than one hundred and fifty historic spots, among them being Lexington battle field, the tomb of Washington, the graves of Lafayette, Thomas Jefferson and Francis Scott Key, the trenches of Valley Forge and the base of Bunker Hill monument. If kindness does not kill the tree, it should certainly thrive in San Francisco.

\* \* \*

The Commissioners of the West Side Parks of Chicago have established at Union Park, a Botanical Garden of hardy herbaceous ornamental flowering plants, systematically arranged, combined in groups representative of the flora of the different countries of the world, and especially that of the United States. They have also in contemplation the formation of an arboretum in one of the larger parks, in which will be placed specimen

plants of each tree, shrub and vine that will prove hardy in and adapted to this climate, each plainly labeled with the scientific and common names. This will be warmly welcomed by all interested in botanical matters, and especially helpful to the public schools.

\* \* \*

According to the report of the Park Commissioners of New York city, more than 5,134 acres of land are set apart for public parks. Below the Harlem river there are some 1,172 acres of parks, most of them developed, Central Park alone covering 840 acres. Above the Harlem there are undeveloped park lands aggregating 3,962 acres, acquired a few years ago, and destined, undoubtedly, to become the splendid playgrounds for the city. In one of them will be placed the botanical gardens, for which the endowment has been raised. But besides all this, the city is about to spend more money for park purposes. Mayor Strong was elected on a platform which called for the establishment of more small parks.

\* \* \*

Preparations for the new botanical gardens in New York City are rapidly progressing and the question of location in Bronx Park is under consideration. But very little money remained to be raised early in the month before the actual work of making plans for the buildings could be begun. Professor N. L. Britton, secretary of the Board of Managers, has outlined the plans of the projectors as follows: Two hundred and fifty acres of land will be set apart for the use of the gardens. Then the city will issue the bonds for \$500,000 for the construction of the buildings. The principal buildings will be the large museum building, which will contain rare specimens of all kinds. There will also be five greenhouses erected.

\* \* \*

Plans and specifications for an Art building to be erected in the Park, are called for by the commissioners of Fairmount Park, Philadelphia, Pa., until October 1, 1895, for which the following prizes for the various successful plans will be awarded. Six thousand dollars for the plans and specifications of the building that shall be adopted; three thousand dollars second prize; two thousand dollars, third prize; one thousand dollars, fourth prize. These plans and specifications must be complete in all respects, and comply with the general requirements and specifications which may be obtained of Russell Thayer, Chief Engineer and Superintendent, Fairmount Park, Philadelphia. The plans and specifications for which prizes are awarded will become the absolute property of the commissioners.

\* \* \*

In an article on "Beautifying Public Thoroughfares," Mr. Geo. R. Knapp, in *American Agriculturist*, briefly describes the difficulties which have been overcome in improving the summer resorts on the New Jersey coast, and the results in the main avenues, and concludes with the following very suggestive paragraph: "Many of our smaller towns are devoid of suitable spaces for parks, but scarcely any have not wide enough thoroughfares that may be treated in a similar manner, or, at least, there are spaces or plots at the intersection of streets which might easily be decorated with trees, shrubs or plants. Individuals are oftentimes slow to respond to the trend of affairs in their own personal properties, but experience has shown that they will wax enthusiastic over a contemplated "public good," when the expense may be made nominal by reason of its division among many. Good roads, well kept walks, shaded streets and bits of landscape architecture in public places, are as valuable to the town or village as are tastefully arranged and well kept grounds to the individual. Such improvements have reached beyond "improvements for improvements' sake," and are on the solid rock of "improvement to increase value."



## CEMETERY NOTES.

A New York syndicate has been organized for the purpose of establishing cemeteries in different cities, and are preparing plans for a new cemetery at Eric, Pa., to be known as Lakeside. It is to be carried out on the modern ideas of cemetery design.

\* \* \*

The perpetual care idea is growing in the smaller cemeteries. In the report of the Pittsfield Cemetery, Pittsfield, Mass., the deposits for perpetual care were larger than usual last year. The total amount is now \$16,309.71.

\* \* \*

Riverside Cemetery, Defiance, Ohio, has contracted with its local dealer for some 6000 feet of water pipe, which will be laid at once. The system will be connected with the city water works and the water will be free to the cemetery. Mr. Frank Eurich, of Woodlawn Cemetery, Toledo, Ohio, prepared the plans for the improvement.

\* \* \*

Work on "Fairview Cemetery" Mattawan, N. Y., that was commenced last fall, under the supervision of B. F. Hathaway, but discontinued during the winter months, has again started, and is being pushed rapidly forward. When these grounds are completed they will be among the finest on the Hudson River, as their natural location is unsurpassed.

\* \* \*

The general drouth of last year has had certainly one good result for the smaller cemeteries, it has imperatively demonstrated the necessity of providing a water supply, where the management is alive to the essentials of a properly cared-for burial ground, and water is decidedly one of the essentials. It is noticeable all over the country this spring that the water question is a leading one.

\* \* \*

The leading article in this issue on "Useful Memorials" is emphasized by the proposed gift of Mr. John T. Brown, of Newburyport, Mass., to Oak Hill Cemetery of that town. If the trustees desire to make a carriage entrance from Parker Street, he proposes to erect entrance gates. The trustees have accepted the gift and the work will be carried out this summer.

\* \* \*

Oak Grove Cemetery, Delaware, Ohio, sends out to the lot owners a postal card upon which is printed the items connected with the annual care of the lots and at the foot is a blank order. The lot owner specifies the items he wishes taken care of, signs the order and returns the card, which is addressed to the superintendent. This reminder in the early spring is a good thing both for the cemetery and the lot owner, and the postal card method commends itself.

\* \* \*

Twenty years ago a small century plant was set upon a newly made grave in the lower Kings River graveyard, Fresno Co., Cal. This little cemetery, neglected and forlorn, is now comparatively desolate, but amid all the ruin and decay, and in spite of the elements, the century plant grew until its flowering period a short time ago, when it sent its flower stalk high into the air and bloomed in its splendor in marked contrast with its surroundings, where weeds hold high carnival.

\* \* \*

The officials of Cave Hill Cemetery, Louisville, Ky., have inaugurated a special carriage service for transporting lot owners and visitors through and about the cemetery, a work which has hitherto been done by the Transfer Co. An attractive and commodious stable has been built and horses and specially

constructed carriages, have been purchased. The carriages are driven by appropriately uniformed coachmen. Cheap rates and frequent service is expected to meet with great favor and liberal patronage.

\* \* \*

The first Confederate burying ground in Georgia was started by Miss Mary Green, who, soon after the battle of Resaca, from seeing so many graves scattered about, conceived the idea of establishing a Confederate cemetery at that place. Her father lived on the spot, and she, with other members of the family, went boldly to work and succeeded in organizing the Resaca Memorial Society. Many trials and tribulations were encountered but the Resaca Confederate Cemetery attests the perseverance and devotion of the ladies to the work.

\* \* \*

The following extract from the address of the Mayor of Grand Rapids, Mich., to his council, displays the relations city councils should hold with their cemeteries: "Under the wise and efficient management of the Board of Cemetery Commissioners, our cemeteries have become an ornament to our city as they furnish a suitable and proper resting place for the honored dead and it is hoped that the same spirit of liberality in this direction will continue in the future as in the past, for I consider it one of the greatest honors to our city or community to have their cemeteries properly arranged and nicely taken care of."

\* \* \*

The records of burials in the cemeteries of Chicago since the settlement of the city has recently reached 500,000. Not all of these are burials in the city proper but are within the limits of Cook county. There are 32 cemeteries in Cook county. There is much interest attached to the early history of Chicago's cemeteries. Before 1835 the city had no settled place for the burial of her dead, and they were interred in most cases in convenient spots near the homes. The following table compiled by the Chicago *Tribune* shows the distribution of burials in Cook county:

Cemetery.	Area in acres.	Established.	Interments.
Calvary .....	110	1859	128,000
Rosehill.....	500	1860	55,000
Graceland .....	125	1859	65,000
Oakwoods.....	182	1865	50,000
St. Boniface.....	36	1863	30,000
Waldheim .....	80	1873	20,000
Concordia.....	60	1872	18,000
Forest Home.....	100	1878	11,000
Mount Olivet.....	80	1885	12,000
Bohemian National.....	50	1877	11,000
St. Maria.....	102	1888	9,000
Mount Olive.....	52	1886	8,000
Mount Greenwood.....	80	1880	5,000
Mount Hope.....	305	1887	1,000
Estimate in the remaining eighteen cemeteries .....			77,000
Total.....			500,000

\* \* \*

Any radical measures of burial reform have a prejudice to contend with, the most deep-seated in our natures, says *The Funeral Director's Journal*. All burial customs, little as many good Christians think it, turn upon the primitive fear lest the dead should rise again, and come and molest their relatives. This, it is said, was the origin of mourning apparel, to disguise themselves, that the ghosts might not know them. This, we are also told, first prompted men to have lead and other impregnable coffins, that the dead might not be able to get out, the most recent instance of which is, perhaps the phosphor-bronze fittings of Lord Randolph Churchill's coffin, which, it is said, will keep the body as fresh 500 years hence as to-day, and, for all practical purposes will be impregnable. In the same way arose



the use of flat grave-stones, to keep the dead in their graves. A traveler in Finland tells of a curious custom, illustrating the belief to this day. They scatter food every week in the churchyards there, the fact being there is no stone in Finland; so, being unable to secure their dead in that way, they think to confine them to the burial ground by supplying them with plenty to eat. Yet the Finns are good Christians.

#### Vines and Grasses.

Among vines suitable for covering trellis work or arches, the plain English Ivy is to be preferred where a green is wanted. *Lonicera Halleana* is a reliable flowering species; *L. aurea reticulata* has handsome variegated foliage. *Clematis paniculata* and *C. flammula* are the best of the small white flowering clematises. It is hard to understand how *C. paniculata* has been such a long time in becoming popular after being introduced, as it is one of the loveliest vines in cultivation. The Chinese trumpet vine, *Tecoma grandiflora*, if grown as a standard and supported by an Iron rod, makes quite a striking object.

The variegated grasses are favorite cemetery plants; they need absolutely no attention beyond cutting over the decayed leaves annually. *Eulalia japonica variegata*, *E. j. zebrina*, *E. univittata*, and *Arundo donax variegata* are the best of this section.—*G. W. Oliver*, in *Florists Exchange*.

#### Death of James W. Lovering.

James W. Lovering, Superintendent of Mt. Auburn Cemetery, Boston, Mass., died at his home in Cambridge, Mass., on Friday evening, May 17th of lockjaw, the result of injuries from being thrown from a carriage a week previous.

Mr. Lovering was an active member of the Association of American Cemetery Superintendents, before which body he had read several valuable papers. Son of the late Prof. Lovering, of Harvard, he was educated in that institution, and he brought this to bear with good results in his twenty years as superintendent of Mt. Auburn, not only in his care of that well known cemetery, but in that he became recognized as an authority in cemetery matters.

Mr. Lovering leaves a wife and several children.

## Correspondence.

Camden, N. J., April 15, 1895.

*Editor Park and Cemetery.*

DEAR SIR:—Will you kindly give me your opinion in reference to the owners of lots being taxed or assessed for improvement purposes in cemeteries; whether a tax or an assessment can be exacted or collected; whether within your knowledge there

has been a court decision upon this particular point in any of the states; or, whether there is any specific enactment, in relation to the assessment or taxation of lot owners of cemeteries in any of the states in the United States.

A case in point is as follows: An act was passed incorporating a cemetery company. The incorporators gave a deed of trust to the cemetery company; to this deed is attached several articles, one of which declares: for the purpose of defraying all or any expense they may assess on each of the said smaller lots, and collect from the owners thereof.

No portion of the money collected as above stated is used for the benefit of any lot, or its owner, further than to gravel the walks, etc., leading to and from the various lots.

*Enquirer.*

In reply to our correspondent, it appears to us that there must be some modifying clauses in the cemetery laws referred to, justifying the above, else it is difficult to believe any purchasers could be found for lots in a cemetery run under such conditions. We have no record of such a case having reached the courts, probably some of our readers may have information on the subject.—[ED.]

## CEMETERY REPORTS.

The annual report of Magnolia Cemetery, Charleston, S. C., shows that in the past forty-five years of its existence, twenty-two hundred lots have been sold amounting to \$169,000. One-fifth of this, by agreement, has been paid to the trustees and this sum by investment from time to time now amounts to \$34,364.57. The income from this is paid to the treasurer to be expended in care of cemetery. The sale of lots for the year ending April 1st, 1895, amounted to \$3,852.15. The perpetual care fund amounts to \$21,016.50. Earnest consideration of the perpetual care of lots was urgently presented by the chairman Mr. George W. Williams, who is the only surviving member of the original board of trustees. The share holders of Magnolia have received an average of about four per cent on their investment, and it is not probable that the dividends will ever amount to more than five per cent, the aim being to make a model cemetery rather than a high paying investment and nearly the entire income is each year devoted to improvements. The severe winters of 1893 and 1894 did much damage to the splendid ornamental trees. Magnolia cemetery affords an excellent example of liberal business management.

\* \* \*

Mt. Hope Cemetery, Boston, Mass., reports for year ending January 31st, 1895, a total revenue of \$23,940.71. This included income of perpetual care fund, \$1,731.01; sale of lots \$6,315.66; care of lots, \$1,789; use of receiving tomb, \$485.50. graves sold, \$3,414. The total expenditures were \$32,990.69, which included the appropriation of \$10,000. The pay rolls aggregated \$22,114.08; salaries \$4,770.38, and bills \$6,106.33.

There were 9224 square feet of land prepared and divided up into 14 lots and 156 single graves. There were also 160 monuments and tablets erected. The number of interments was 1902, of which 1310 were in the city lots.

#### Association of American Cemetery Superintendents.

O. C. SIMONDS, "Graceland," Chicago. President.

G. W. CREESY, "Harmony Grove," Salem, Mass.. Vice-President.

F. EURICH, Woodlawn, Toledo, O.. Secretary and Treasurer

The Ninth Annual Convention will be held at Richmond, Va., September 18, 19, and 20, 1895. A number of interesting papers have been promised.



### Publishers' Department.

Park Commissioners and Cemetery trustees are requested to send us copies of their reports.

Photographs and descriptive sketches of interesting features in parks and cemeteries are solicited from our readers.

To cemeteries subscribing for five or more copies of the *PARK AND CEMETERY*, we will send one copy gratis to the local Public Library.

Cemetery officials in upwards of fifty cities and towns subscribe for extra copies of *PARK AND CEMETERY* for their trustees and lot owners.

J. W. Sponable, president of the Paola Cemetery, Paola, Kan., has *PARK AND CEMETERY* sent to the Paola Free Library.

The article on "Useful Memorials" in this issue should be brought to the attention of well-to-do lot owners who have not erected memorials.

E. T. Barnum, Detroit, Mich., is making some handsome entrance gates with arch for the Lakeside Cemetery, at Port Huron, Mich.

#### RECEIVED.

An illustrated pamphlet giving a brief history of Lexington Cemetery, Lexington, Ky., and a report of meeting of lot owners, March 11, 1895.

Constitution and By-Laws, Rules and Regulations of the Altoona Fairview Cemetery Association, Altoona, Pa.

Organization and By-laws of the High-

land Park Cemetery Association, Kirksville, Mo.

City of Cambridge, (Mass.) Park Department, Annual reports for the year 1894.

Reports of Park Commissioners, city of Seattle, Wash. 1892 and 1893.

*The Prospect Union Review*, conducted by Harvard students and wage earners, Cambridgeport, Mass.

The Illustrated Catalogue for 1895 of Nanz & Neuner, Louisville, Ky., contains a large assortment of seeds, plants and bulbs, as well as supplies of all kinds for landscape and garden work.

E. T. Barnum's fence catalogue, No. 792, illustrates and describes a large number of patterns of wire and iron fences, as well as vases, settees, chairs, grave guards, and other lawn furniture, to which prices are attached. There is a lot of information in this catalogue which can be obtained by addressing the firm at Detroit, Mich.

#### PRESS NOTICES.

*PARK AND CEMETERY* is well gotten up and contains much matter of interest. *Boston Herald*.

Modern cemeteries are really gardens instead of church yards, and this excellent serial (*PARK AND CEMETERY*) has always seemed to be an effective laborer in the great field of landscape gardening. *Meehan's Monthly*, Philadelphia.

What has been the *Modern Cemetery*, Chicago, is now *PARK AND CEMETERY* and is improved in various ways. *The Trade Press*, Chicago.

## CEMETERIES A SPECIALTY

40 Years Experience.

Lithograph and Nigrosene Illustrated Plans sent on application.

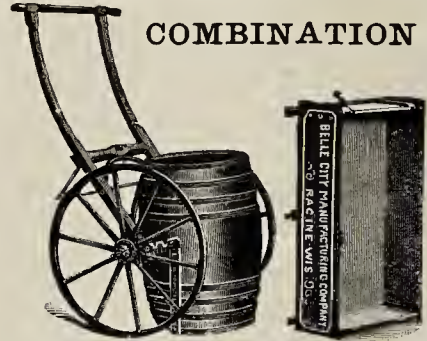
**B. F. HATHEWAY**, Cemetery Engineer  
STAMFORD, CONN.



Handsome Illustrated Catalogue sent free on application

**G. VAN TUBERGEN, Jr. HAARLEM, HOLLAND**  
**CHOICE DUTCH BULBS AND ATTRACTIVE BULBOUS PLANTS**  
CATALOGUES FREE.  
GABEL & CO. SOLE AGENTS. - BOX 920, NEW YORK

### WATER and TRUCK CART COMBINATION



Any number of adjustable, swinging and dumping barrels can be used with one truck.

**BELLE CITY MFG CO., Racine, Wis.**

Send for circulars of our different Hand Carts & Barrel Trucks.

## FROM NOW UNTIL

# July 1st, Not Later.

There is no more useful garden material than what is known as Dutch Bulbs, Hyacinths, Tulips, Narcissi, Crocus, etc. They give for a small outlay of time and money an abundance of flowers in the house from December until April, and in the garden almost before the snow is off the ground in the spring until the middle of May. These bulbs are grown almost exclusively in Holland, and in enormous quantities, where they are sold at very low prices. Usually they pass through the hands of two dealers, and more than double in price before reaching the retail buyer in America.

By ordering from me **now** instead of waiting until fall, you save from 25 to 50 per cent, in cost, get a superior quality of bulbs not usually to be obtained at any price in this country, and have a much larger list of varieties to select from. My orders are selected and packed in Holland, and are delivered to my customers in the original packages immediately upon their arrival from Holland, perfectly fresh and in the best possible condition.

If you wish to take advantage of my very **low prices**, I must have your order **not later than July 1st**, as I import Bulbs to order only. They need not be paid for until after delivery, or taken if not of a satisfactory quality.

My price-list is now ready, and may be had for the asking.

#### A FEW OF THE PRICES.

	Per 100	Per 500
Fine Mixed Hyacinths	\$2.50	\$11.00
" " Tulips	.50	1.85
" " Crocus	.30	1.25
" Named "	.55	2.25
Narcissus Poeticus	.65	2.00
Double Daffodils	1.50	6.60

## J. WILKINSON ELLIOTT,

Landscape Architect,

Horticultural Buyers' Agent.

PITTSBURGH.



# PARK AND CEMETERY.

FORMERLY THE MODERN CEMETERY.

A Monthly Journal Devoted to Parks and Cemeteries.

R. J. HAIGHT, Publisher,  
384 Dearborn Street, CHICAGO.

Subscription \$1.00 a Year in Advance. Foreign Subscription \$1.25.

VOL. V. CHICAGO, JUNE, 1895. No. 4.

## CONTENTS.

EDITORIAL.....	55
PARK BUILDING .....	56
*AMERICAN CEMETERIES ARE PAGAN.....	57
CARPET BEDS IN PARKS.....	59
*GOLDEN GATE PARK, SAN FRANCISCO.....	59
*ELM GROVE CEMETERY, MYSTIC, CONN.....	63
*FLOWER BEDS AT GIRARD COLLEGE, PHILA.....	64
*FOUNDATIONS.....	64
*ISLAND CEMETERY RECEIVING TOMB, NEWPORT, R. I.	66
CONSTITUTIONAL RIGHT TO CONSTRUCT HIGHWAYS THROUGH CEMETERIES.....	67
*CONFEDERATE MONUMENT, CHICAGO.....	67
*GREENHOUSES—HOW TO BUILD VI.....	68
PARK NOTES.....	69
CEMETERY NOTES.....	70
CREMATION—CORRESPONDENCE—CEMETERY REPORTS	71
PUBLISHER'S DEPARTMENT.....	72

\*Illustrated.

A GOOD work has been inaugurated by the recent exhibition of the National Sculpture Society in New York, in its successful effort to display works of sculptural art in connection with landscape gardening. The American public have little conception of the Italian Garden, or the foreign country seat, with their statuary placed here and there to enhance the beauty and lend a charm to the surroundings. There is no hap-hazard work in such display. The subjects are either chosen with an object in view, or when acquired are disposed with a definite study as to appropriateness of disposition. This exhibition of the Sculpture Society has clearly demonstrated on this side of the Atlantic the value of statuary in artistic landscape effects as well as the appropriateness of a setting of verdure for certain forms of ideal statuary. The value and beauty of our parks would be immeasurably enhanced by such a combination of nature and art, and the future would assuredly proclaim the wisdom of this evidence of our enlightened civilization.

IN another column will be found an illustrated article, written by a foreign visitor who paid considerable attention to our cemeteries while here, and whose criticisms are valuable in their sug-

gestiveness. One of the most striking object lessons offered by the large majority of our cemeteries today is monotony in monumental memorials. There is, generally speaking, a certain lack of individual taste displayed by the average lot-owner in the selection of a monument. It would almost seem in most cases, as though a monument on an adjacent lot had caught the passing fancy of the would be purchaser and a duplicate was therefore ordered. This condition of things, so detrimental to the higher interests of the cemetery, can find a remedy in the rule to allow no monument to be erected without the approval of the officials, based upon the submitting of the design selected for such approval. Whatever arbitrariness or deprivation of personal rights might be suggested in such a rule, would be dissipated on reflection. The general appearance of a section is the increasing ratio of the appearance of the lot, and so on of the whole cemetery. An appreciation of this fact by the lot owner will eradicate any personal objections that may arise on the point of interference with individual rights, for the beauty and welfare of the cemetery should be the object to which all individual views are subservient.

AN important matter in connection with cemetery work is the foundation of monuments, on which subject an article will be found in another column. The work itself affords so much latitude for carelessness and incompetency, to say nothing of dishonesty, that the subject is worthy of far more attention by cemetery officials than it has ordinarily received. Both the material and workmanship should be carefully considered and supervised, and that in relation to the soil and surroundings,—questions of the utmost importance. The unsightly condition of many country cemeteries is largely due to carelessness or cupidity in this direction, and even in the more pretentious cemeteries of our large cities, instances are quite common where foundations have been so faulty as to imperil the monument itself, as well as reflect on the management for inattention to such important work. From such general experience, the conclusion is manifest that the cemeteries themselves should undertake the work of constructing all foundations for monuments. In this regard a very pertinent suggestion offers itself. The work of building foundations is of such a nature that a source of revenue is open to the cemetery management, which is taken advantage of by many of the large cemeteries,



and for the reasons indicated should be realized by all.

THE Boston *Herald* takes exception to the statement in our editorial in the March issue, that "apart from the burial of the dead the requirements for the cemetery are largely those of the park, and that more often than otherwise the rural cemetery is practically the village park." It then says: To make a park of a cemetery should be as sternly discouraged as the other tendency toward ostentatious, and consequently, vulgar display in the way of mortuary monuments that, as a rule, disfigure our modern burial places. There is something unspeakably repugnant in the idea of converting a ground for burial, which should be characterized by an air of peace and serene beauty, either into a place of public recreation, or for the assemblage of costly examples of the stone-cutters art set amid gaudy flower beds." These views have been expressed in other words time and again in these columns, and we therefore cordially endorse them. But the fact remains that in many villages the Cemetery is the only public place of a park like character with natural adornment, and it is sought for quiet reflection rather than the character of recreation the reviewer evidently had in mind.

#### Park Building.

Mr. George R. Cook, Superintendent of Parks, Cambridge, Mass., in an article under the above head in *The Prospect Union Review*, gives some interesting matter on this subject. In referring to the contract executed between the President and Fellows of Harvard College and the city of Boston, whereby it is provided that the Arnold Arboretum shall be set apart and maintained as a public park for a thousand years, he says: Think of a spot of land upon which it is solemnly agreed that nothing but beautiful things shall flourish for a millenium! The imagination can hardly conceive so long a contract. Think of the generations which will tread the paths and enjoy the shade of those oak trees! Everything which can change will change before the end of the thousand years. Yet it is not folly to plan that this park shall endure, for that which is really beautiful now will be beautiful then; and men then will be as anxious, yes more anxious to preserve that which ministers to a more beautiful public life than they are now.

Continuing, he says: "Nothing endures like earth work, we are told. The history of the older portions of the earth proves this. When man moulds a spot upon the earth into picturesque and beautiful forms; when he builds solid roads, so skilfully planned that nature shall adopt them for her own;

when he plants trees upon the hillside and covers the meadows with turf, he has done the most permanent work which it is possible to do with material things.

"Park building is, therefore, different from almost any other public enterprise. A park cannot wear out. If wisely planned at the outset, it cannot deteriorate in value. Instead, its value constantly increases. The more ancient a park, the more its value. Decay adds to its wealth. It is least valuable when new. Not so with many other things for which public money is spent. Public buildings, bridges, sewers are worth most when new, and then at once begin to deteriorate and finally become entirely useless. But a park never ceases to increase in value as long as there are people to enjoy its benefits.

"This element of permanency in parks means, therefore, that in building parks we are building final things for our city. Very little of our municipal work is anything more than transient. We outgrow our public buildings. Streets, which are the principal thoroughfares for one generation, become the by-paths of the next generation, as fashion changes or trade advances. Sewer systems become antiquated and useless. \* \* \* But a wisely-located park is a finality. It is the highest and best use to which land within city limits can be devoted, and future generations can be trusted to preserve it from any lower uses.

"The cultivation of the beautiful has ever been found to be a good municipal investment. History cannot show that any city ever made a mistake in cultivating the beautiful in art or nature. Painting, sculpture and the Groves of the Academy, attracted to ancient Athens all that was best in Greece. Her schools were crowded, her marts of trade enriched, because she arrayed herself like a queen in her beauty. So it was with Florence and the free mediæval cities; and so it is today preeminently with Paris whose drives and parks and splendors of art have attracted the wealth of the four quarters of the globe to herself. What has not the investment in the Sistine Madonna been worth to Dresden? What but its marvellous beauty, was the great attraction at the World's Fair that brought millions of pilgrims to Chicago?

"Of course the most beautiful cities in the world did not become so through any commercial instinct. They cultivated beauty for its own sake. Nevertheless, it is true that wealth and refinement and the good things of this life have flowed into those cities.

"It is an old saying that has given inspiration to many that 'We should do our utmost to encourage the beautiful, for the useful encourages itself,' but it would be more to the point if in our public



affairs the New England mind might fully realize that the beautiful *is* useful. I know that it is urged, and truly so, that in this country we have no resources to expend for civic decoration, except those derived from self-imposed taxation; but even this difference between European and American cities does not alter the fact that civic decoration pays, that beauty brings dividends into the city treasury.

"The history of the park movement in American cities shows that civic decoration attracts culture and refinement, wealth and plenty. Park cities are cities to which money tends. Thousands of people establish their residences in such cities because of the added pleasures of life and of the opportunities to display their wealth in finely situated houses and in rich equipages upon the park driveways."

#### American Cemeteries are Pagan.

IMPRESSIONS OF A FOREIGN VISITOR.

The impression was deeply marked upon my mind when two years ago I first had the opportunity of looking through several American cemeteries and was intensified the other day when I spent an afternoon in Greenwood. I have seen American cemeteries in New England, around Chicago, in many inland places, as well as those which are dotted around Brooklyn on Long Island, and I speak of Greenwood as being, not so much a fair specimen of them all, as rather a model, typical of that which the other cemeteries aspire to be.

Let me say first, that in all respects except the one of which I shall speak in hostile criticism, American cemeteries compare most favorably with those of the old world. It appears that in their inception much more ground was available for them than we have to spare for such purposes on the Eastern side of the Atlantic, and great advantage has been taken of this extensive area and of all natural inequalities of surface which break the monotony of a landscape; whilst more has been done probably in the way of artificially produced hills and valleys with lakelets along them to improve the general appearance of the place. Of foliage there is abundance; which we all understand to be a most important consideration in a cemetery, both for the shade which it affords to those who visit the place and for the hygienic chemical action which all trees exert so largely, particularly in a burial ground. I have much admiration for the slopes and banks, green as in the Emerald Isle, for the substantial granite which forms the facades of the vaults, and for the great variety of cenotaph and sarcophagus, pyramid and mausoleum, some of which are ornate even to worthiness of their title, and for many blocks which were wrought into their shape with reason and now boldly bearing honored names.

The arrangement and the nomenclature of the roads and paths in these cemeteries are admirable. How can I quote from them? "Landscape Avenue," "Forest" and "Woodlawn," in endless variety and across these avenues are the paths named

after every blossom that blooms upon English hedgerows and flowerets that sparkle on prairie breadth or mountain side in spring, whose very names suggest odors of sweetness and thoughts of peace which are very well inspired in these surroundings. The cypress and mistletoe, willow and palm, and other indications more sombre are found here also, but amid all these, which constitute the



admirable natural environment, there stand those stones which to my mind are evidences of the lack of Christian thought and Christian sentiment which surely should

be found around the abodes of the dead.

I have no difficulty in proving this. I stood upon a hilltop which is adorned by the Morse tomb, in itself a thing of beauty, though of composite architectural character. Around and within view from that hill-top were probably more than a thousand various memorial stones, and among them all I counted but four crosses which surmounted other erections, one cross sawn out in a headstone, and only one Latin cross pure and simple.

There is no lack of work or wealth spent up-



THE MAUDE CROSS.



on these tombs. The material is excellent. They are enriched with moldings and panels, bordered with banners and worked in mosaic with shells, but of all the best of them I do not hesitate to say that their character is pagan. I think there are more obelisks than any other order of tomb, and who that knows the origin of the obelisk as a memorial can look at it without a blush of shame. My conviction is that those who use the obelisk never have thought of what they were doing, or they would certainly not have done, as can be seen to be repeatedly done, embellished the apex of the obelisk. There are obelisks here whose point finishes in a heavy molding, or is surmounted with a cap, or has an angel standing on it. One such unfortunate creature spreading his wings as if attempting flight, but with wings so small they would not have lifted his arms if they could fly. Where the obelisk has not suffered attempt at adornment at its apex, it is stood on a base out of all character with itself. On any base one can justify space enough to place an inscription, but most of these consist of more bases than one, all over done with conventional molding. Returning to the point of the obelisk, some are finished in tasseled drapery, others are carved, surmounted by emblematic figures, have urns with flame showing, and one, perhaps most offensive thing of all, was paneled and carved all over.

I observe also that the ledger shaped tomb appears to have no admirers among your monumental masons, for I suppose that they are the sinners above all who deal in America in the matter of monumental taste. There are also but few broken columns, which I venture to commend, as to my mind to erect a broken column bespeaks irreverence. What should be done then? Surely the answer is simple. The cross is the emblem of Christian faith. The more simple it is in its character, the less it detracts from its original significance. In the course of ages the cross has been used by various nations of people and in various forms, all of which forms lend themselves now with propriety to memorial uses.

The illustrations and descriptions I give herewith relate to existing English memorials.

The cross to John Augustus Smith is an Iona cross, that early settlement on Scotland's western coast where the monks of the sixth century founded a settlement and erected their cross, which still stands, though this pattern is very much more worn than might be imagined from this modern representation of it.

A cross erected to Alfred Crawshay is of the order, known to us as a rustic cross, but all the details were suggested by his widow for his memorial and it is certainly a unique design; more

than that, it is a unique erection. No two were ever made of them. The rock hewn base is represented with some cut flowers which are supposed to have been distributed upon it, whilst from the interstices grow ferns. The cross is the imitation of rustic timber supposed to have been stood in its base until it had been grown around and entwined with luxurious passion flowers. The head and one arm of it carry a crown of thorns carved in exact imitation of the original. The passion flowers have entwined themselves through and among the thorns and spread upon the arms and head of the cross.

Surely these are superior in many ways, and are worthy the attention of those who have much to say in deciding what tomb shall be raised over the disciples of Jesus Christ in America.

Another evidence of lack of Christian sentiment in the cemeteries is the exceeding scarceness of even an attempt at Gothic shaping. There stands in Greenwood a row of five



CROSS IN MEMORY OF JOHN A. SMITH

in one large plot, so bald in their outline that they might have been meant for barrier posts. On one of the larger headstones the adornment consists of a soup bowl vase. Headstones which with us are generally finished with a lance head, sharper or blunter, in America are but roughly rounded. Where carved adornment is attempted it is generally limited to stiff leaf foliage, the earliest kind of carving which Gothic builders did, and from which they wholly delivered themselves in the thirteenth century.

Concerning inscriptions, you largely adopt raised letters, which are very plain speaking, and which if protected in a panel may be durable, but on many of your tombs there is no surrounding protection and the letters are knocked off. I would suggest the consideration of lead letters, finished flush with the marble surface, said to be more imperishable than the marble and which are shown on all tombs of which I give you illustrations. They are in general use in England on all marble tombs.

*Halford L. Mills.*

Wooded Island, Jackson Park, Chicago, is this year a magnificent rose garden.



**Carpet Beds in Parks.**

There appears to be the greatest and most irreconcilable difference of opinion between the natural school of landscape gardeners and the florists and other plantsmen, respecting the merits of carpet-bedding in public parks. The landscape gardeners insist that the designed bed is unnatural in effect, inartistic and irrelevant to its surroundings, and this position cannot be successfully assailed. The gardeners, on the other hand, declare that the greater number of the visitors to the parks demand beds of design, and that, moreover, the love of color and of formality is inborn in the human mind. This position is also unassailable. If both contestants are right, how are the two ideals to be brought into harmony?

Before attempting to answer the question, we must first discover what the purpose of a park is. It is generally asserted that the park is made for the purpose of affording recreation and entertainment to the people. This is no doubt true, and yet these aims must be taken in their broadest and most liberal sense. Libraries and art galleries and museums may be said to exist for much the same purpose, and yet we all admit that their mission is quite as much to instruct as to entertain. In fact, they entertain because they instruct us without our knowing it. It is important, then, that they instruct us truthfully and fundamentally. The park, I take it, should be a public educator. It should represent the best emotions and aspirations of the soul. The modern evolution of the race points to nothing more clearly than to the fact that we are growing away from the old formalisms and artificialisms into a freer and broader atmosphere of naturalness. The history of the evolution of the landscape garden—that area which is given nature like effects—is a continuous chronicle of the emergence from conventionalism or fashion into a love and interpretation of nature. Judged by this history, the modern naturalistic school of landscape gardening, in its essential features, must endure. Carpet-bedding is a mere accessory conventionalism, a fashion, which has no relationship to the general onward progress of the art of making landscape gardens. It is clear, therefore, that it has no place in any general scheme or design of park-making. It is a mere trivial accessory, tolerated to appease a feverish taste which it, itself, has been largely the means of awakening.

Yet I would not discard the carpet-bed outright. It will disappear with the further evolution of the race. I like to see good carpet-bedding, for the same reason that I like to see a curious mechanism,—it exhibits the ingenuity and patience of the maker. Now the place for the carpet-bedding is all together, in some place set aside for it and somewhat cut off from the landscape gardening. It is of

exactly the kind as the Zoological Garden, and the eagle cages. It is properly a part of the museum. I often think that park superintendents ought to charge admittance fees to such areas, where those who are curious to see specimens and wonders can satisfy their desire, in the same way as they can by going to a museum or a menagerie. If, then, the carpet-beds are kept off the landscape—where they are mere interjections—there can be no possible objection to their use.

It is a specious argument of the friends of these formal beds, that people demand color. Of course they do, but that is not proof that they want color in this form. Let some bold gardener put the same amount of color into a free and easy planting—into a generous, good-natured border of hollyhocks, phloxes, asters, golden-rods, lilies, and the like,—and then see how the laced and primped and featureless carpet-bedding will suffer in the comparison! For myself, I find little recreation in our city parks. I go there to see the sights, and I walk and gaze until tired out. When I want recreation, I go into the fields or woods, and sit down and rest.

*L. H. Bailey.*

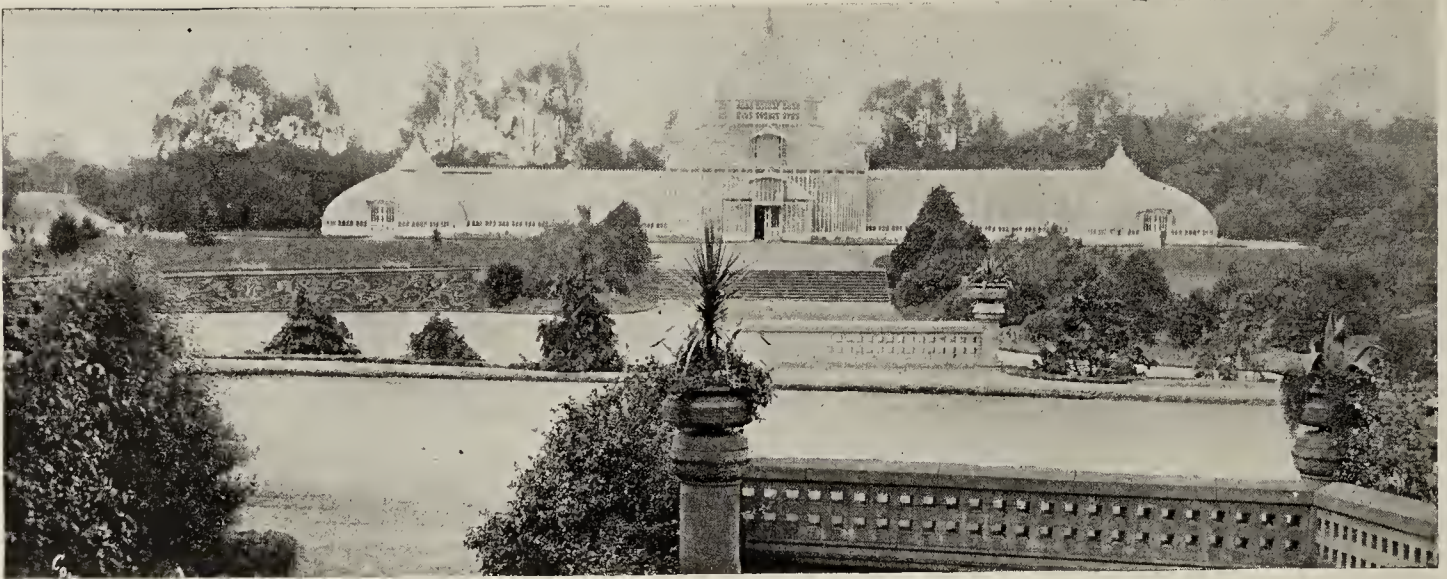
**Golden Gate Park.**

Some of these days the parks of San Francisco will be famous as far as civilization extends. Golden Gate already ranks among the notable parks of America, and its natural advantages are such that with proper care it must increase in beauty for many years to come. The great Presidio military reservation and Sutro Heights, complete, with Golden Gate, a picturesque chain of parks which cover several thousand acres, and overlook for miles the Pacific Ocean, the Bay of San Francisco and the bold promontories of the Marin Coast. It is now proposed to build a broad and splendid boulevard extending southwards from this chain of pleasure-grounds and curving around the mountains on the western side of the Santa Clara Valley to San Jose, thirty miles distant, and to plant it with double rows of palms and other rare trees. The scheme has been taken up with so much energy by the Half Million Club and other progressive organizations of San Francisco that its accomplishment appears probable.

Returning to a more detailed description of Golden Gate, the first and most notable of California parks, the reader must conceive of the San Francisco peninsula as a high and rugged mass of rocky hills, sand dunes and narrow valleys. It is really the northern end of one of the many mountain chains which constitute what is called the Coast Range of California. Winds and fogs sweep across, but it is almost frostless, and capable of wonderful horticultural results, in skilled hands. Aside from a



## PARK AND CEMETERY.



CONSERVATORY, GOLDEN GATE PARK, SAN FRANCISCO.

few public squares the parks and pleasure grounds of the peninsula lie west of the main mass of the City and extend to the Ocean. Golden Gate park contains 1040 acres extending westward from Stanyon Street in a long parallelogram to the ocean. It has a most abundant water supply and a marvelous diversity of surface. For miles in this part of the peninsula, the rounded sand hills and curving sand valleys once extended, somewhat wooded in places with gnarled scrub-oaks from ten to twenty feet high, or clothed with bush-lupins and multitudes of wild annual flowers, or sometimes mere drifting wastes of brown and gray sands. In such places the Park authorities planted millions of roots of a famous perennial sea-beach grass, *Arundo arenaria*, that bound the sand together and gradually formed better soil. Lupin bushes were next planted, and soon the slopes gave place to greensward, flowers and trees. In other places the soil was immediately fit for Eucalypts, Acacias, species of Broom, Gorse and an immense number of semi-tropic trees and lesser plants.

The undulating sand hills rise from twenty to a hundred feet above the sea level; Strawberry Hill, the central height of the Park, is three hundred feet high. On this hill is an observatory and water reservoir, and around its base is Stow Lake, an irregular and very picturesque circle of water, containing three rocky islands. The lake itself lies at such a height above the park that it serves as a reservoir supplying water for irrigation. It is becoming one of the most beautiful places in Golden Gate, so wide a view of ocean, bay, city and the surrounding country is obtainable even from the surface of the lake. Elaborate plantations of trees, ferns and shrubs have been commenced over the hill, and about the shores. C. P. Huntington gave \$25,000 to construct a cascade and waterfall from

the reservoir on the top of Strawberry Hill to the lake below, and they are now completed. The cataract is two hundred feet long and has a descent of forty feet; the water then makes a plunge of fifteen feet, passes under a roadway, and descends seventy-five feet to the lake. Wells within the park grounds supply the needed water, and the pumps now built are capable of lifting 1,500,000 gallons to the upper reservoirs every twenty-four hours. Flowing artesian wells have also been developed south of the Park, on city lands, and a large supply can thus be obtained. Water in abundance is an especial necessity to Golden Gate Park, as flowers, plants and lawns would soon disappear without it.

Although San Francisco is very proud of its Park, which has received the most careful and competent management, and has been "out of politics" since its establishment, the appropriations have never been as large as for similar parks elsewhere. New York is said to spend about \$190 per acre on Central Park for maintenance alone, while Golden Gate spends about \$64 for that purpose, and about \$96 on construction which is necessarily the princi-



THE LAKE IN GOLDEN GATE PARK.





VIEW OF WATERFALL IN GOLDEN GATE PARK.

pal item in a new Park. The annual income is about \$210,000, and the whole investment of the city, including costly litigation for the recovery of the lands which were a part of the old Spanish pueblo grant, has been \$2,500,000 to date. It is now evident that the city will soon occupy all the vacant areas of the peninsula, west to the ocean, and every year the value of this great breathing space increases.

The two hundred and fifty acres now more nearly improved, contain about twenty miles of drives, a superb speedtrack, seventeen miles of walks, three miles of bridle-paths, ten acres of concourse, extensive lawns and arboretums, the group of conservatories, the Arizona garden, Deer Glen, the Buffalo paddock, the Aviary, the children's Quarters, Recreation grounds, Music Stand, Casino and water canal, various monuments, statuary and many lesser attractions.

Farther west lie the 160 acres which were occupied by the Midwinter Fair and some of the best of the 120 buildings remain, besides much of the planting done at the time. It is estimated that the total expenditure for construction at this Fair was about \$1,500,000, and the total number of paid ad-

missions was 1,434,281. The management after paying all expenses, had a large surplus, and it was decided to create a memorial museum in Golden Gate Park, in the Midwinter Fair Art Building. About \$147,000 has been spent on the museum, which was formally opened last March. It already contains a great deal that is interesting, but its educational value depends, of course, upon the character of the men who identify themselves with its future development. There is as yet no great museum of national reputation on the Pacific Coast.

The most attractive feature of Golden Gate to a tourist is probably the extensive floriculture, and the vast masses of such brilliant flowering trees as the Acacias. In many places the broken, rocky slopes are set with tree Ferns, Rhododendrons, rare Palms and a host of semi-tropic plants. Cinerarias and Fuchsias, for instance, one sees growing all the year round, and many of the older portions of the Park are masses of bloom at almost every season. The additions of a single year embrace about 112,000 trees and 170,000 herbaceous plants, besides the bulbs, vines, etc. One finds thriving specimens of twenty six species of Acacias, forty-seven of Eucalypts, forty of Pines, thirteen of Firs and Spruces



and thirty of other conifers, besides Magnolias, Grevileas, Dræcenas, Pittisporums, Palms, Brugmansias, Budleyas, Clianthus, Chorozeas, Azaleas, and many other shrubs and trees—nine hundred species in all according to the last published catalogue. The out-door garden includes Calceolarias, Heliotropes, Passifloras and Tacsonias, Begonias, and similar plants. The conservatories contain forty-nine species of Palms, one hundred and ten species of ferns, nearly two hundred species of orchids, eighteen species of Water-Lilies and five hundred species in general collection. Some of the older trees, such as Sequoias and Araucarias, begin to be impressive; the time will come when Golden Gate will be famous for its grand single trees. It is expected that the entire western half of the park will be planted to forest—an arboretum on a large scale, extending to the beach, and this will not only shelter the more ornamental portion, but will prove an added attraction. Beyond is the great boulevard of the ocean beach from Sutro Heights south for miles.

So much for the broader outlines, historical and botanical, as they appear to the student of American Parks. Anyone who has visited the famous parks of Boston, New York, Philadelphia, Baltimore and Chicago, all so interesting and yet so different, can easily see that Golden Gate has a character of its own, and is already one of the noteworthy institutions of California. Nowhere is it possible to see more readily the characteristics of the people of San Francisco and the surrounding country than at Golden Gate Park. It has become the favorite place for the celebration of anniversaries, society reunions and similar meetings. Many and valuable gifts have been bestowed upon it by private citizens and more than one millionaire, it is said, expects to remember it in his will. A peculiarly fortunate management has always kept it near to the people, and it has received little or no unfriendly criticism. Newspapers of every shade of politics have always united in loyalty to the principle of maintaining the Park.

It follows, therefore, that all classes of people use Golden Gate to its fullest extent. For at least nine months in the year and during a large part of the three remaining months, immense numbers of people go to the Park daily. One is surprised at the number of Chinese who are seen there regularly with their children. These oriental children are amazingly polite, and enjoy everything, riding in the boats, using the swings, patronizing the merry-go-rounds and feeding the deer and squirrels. In a few weeks the beautiful little Japanese Garden, which was one of the most charming parts of the Midwinter Fair, will be reopened as a permanent

part of the Park. On certain holidays the silks and satins of sedate Chinese merchants fairly illuminate many a winding walk, and harmonize excellently with Australian Clianthus and Asiatic magnolias, massed in such rich profusion on the terraces. Especially does one see these almond-eyed Orientals in the great conservatories which contain the finest flower collection on the Pacific Coast; or in the children's department, watching the sober gambols of their olive-hued fac-similes.

Allusions have been made to the Children's Quarters, and this department deserves a much more extended notice. They are said to be larger, more complete, and better situated than those of any other American park. Sharon House an attractive building of hewn stone is the head-quarters here; the lawns, play-grounds, carousel, riding-donkeys and goat carts, and various other attractions are grouped near it. The aviary, squirrel-house, and the steel-barred dwelling place of Monarch, the huge Sierra grizzly caught for the *Examiner* by Allen Kelly a few years ago, are all within a few minutes walk. The park certainly needs a more extensive and classified collection of living animals, but it already has the nucleus of quite a menagerie, and some particularly fine single specimens.

The park grows on year after year, the delight of many thousands of people, broadening into a more perfect charm under the skilled management of its superintendent Mr. Mc Laren. Year after year its trees grow larger, and its blossoming acres are more splendid than before. The city creeps closer, and blocks of houses must some day wall it in on north, south and on east. But the west will ever be free, reaching out to the Pacific, and a chain of seaside resorts will stretch up and down the beach, linking together the various nuclei of the present time. Manhattan Beach and half a dozen of the Atlantic Coast seaside resorts may be considered as prototypes of the summer resorts that are beginning to thrive in nooks along the western edge of the peninsula, outside of the park lands. The



THE PACIFIC OCEAN FROM GOLDEN GATE PARK.  
ocean beach itself forms the western boundary of the Park, and the famous Seal Rocks are full in sight.  
*Charles Howard Shinn.*



**Elm Grove Cemetery, Mystic, Conn.**

In the south-eastern part of Connecticut, in New London county, bordering on Long Island



ENTRANCE TO ELM GROVE CEMETERY.

Sound, nestles in what is known as the Mystic Valley, one of the most beautiful, well kept and tastefully adorned cemeteries to be found in the state, and Connecticut is distinguished for her incorporated burial places.

"Elm Grove" is not yet fifty years old, it embraces fifty acres of land, and these are laid out in plats of different sizes and shapes, well related to the undulating field and the tortuous paths of this "God's acre." It is situated on the banks of the beautiful Mystic river, whose waters shimmer in the light, like waves of liquid silver: the cemetery slopes towards the setting sun, "beautiful for situation." Choice trees, luxuriant maples and spreading elms, stand in chosen spots like faithful sentinels, to guard this quiet resting place of the absent,—the dead.

We have visited many of the larger and more pretentious cemeteries of our great cities, and while there is no competition or rivalry on the part of the trustees of "Elm Grove" with such, we find it truly comforting and restful, to turn to the tranquil se-



VIEW IN ELM GROVE CEMETERY.

clusion of the village cemetery, whose beauty and tasteful care lifts thought above the jarring elements of discord, and is ever saying, "Come unto me, ye that are weary and heavy laden and I will give you rest," rest to the troubled spirit, rest from the longings of vain ambitions, rest from suffering and rest in hope, leaning on the bosom of the Lord, for He hath said, "I am the resurrection and the life."

Great praise is due to the superintendent of "Elm Grove," Mr. Henry Schroder, who for twenty-eight years has devoted his entire time to the duties of his office. The continued service of such a faithful officer is well attested and discountenances frequent changes in the management of our cemeteries.

The entrance to Elm Grove cemetery, represented by the cut at the head of this article, is one of marked and massive grandeur, and is a tribute of affection, alike to the dead and the living. It is a memorial erected by the children of Mr. and Mrs. Charles Henry Mallory, to perpetuate the love and devotion to honored parents, and, is in itself a tri-



VIEW IN ELM GROVE CEMETERY.

bute of nobility to the tender memories and generous hearts of the children of such parents.

It consists of three arches, the main one for a drive-way, and the smaller ones on each side for pedestrians. The main arch is twenty feet wide by twenty-two feet high; the smaller arches are each six feet wide and ten feet high. Each arch has double gates of wrought iron. The arch is fifty-four feet long by six feet thick, and thirty-two feet high with side walls extending each way. There are about nine hundred feet of wall, twenty inches thick by three feet eight inches high, with rugged substantial cap stones. It is built of red Westerly granite.

Over the arches and just beneath the cap-stone is chiselled in bold and striking letters the sacred words:

I AM THE RESURRECTION AND THE LIFE,  
and above the curve of the arch on either side the Greek monogram, *Alpha - Omega*.



The accompanying illustrations will convey a correct conception of scenes in Elm Grove Cemetery.

The cemetery has a receiving vault which is located in one of the most beautiful portions of the grounds, and is surrounded by monuments of choice and finished work, both in material and art.

IN MEMORIAM.

These passionless marble tributes of affection and devotion, speak by night and by day of *love* undying, of *love* that:

"Warms in the sun, refreshes in the breeze,  
Glow in the stars and blossoms in the trees;  
Lives in all life, extends through all extent,  
Spreads undivided, operates unspent."

Elm Grove Cemetery Assn.,  
Mystic, Conn.

M.

**Flower Beds at Girard College, Philadelphia.**

Our illustration shows one of the flower beds at the famous Girard College, Philadelphia. The



BED OF CROTONS, GIRARD COLLEGE, PHILADELPHIA.

flower beds at this institution delight thousands of visitors in the summer time. The grounds consist of about 40 acres, and though much of it has to be reserved for recreation grounds for the 1,500 boys which the college contains, there is ample room reserved for the ornamental department, which is mainly near the entrance and adjacent to the main building.

A large round bed near the building has for a center piece a nice plant of a palm, *Lantana Borbonica*, and it fits its position nicely. Around it are the dwarf French cannas now indispensable for summer bedding. They are of many and beautiful colors, and bloom till frost. Next comes the plant with rosy bronze leaves, *Acalypha musaica*, its like for usefulness hardly to be found. Following this is the *Achyranthes Verschaffelti*, with its dark red leaves. Next comes a variegated leaved geranium, *Mountain of snow*, and lastly, and on the outside, *Coleus Golden Bedder*. The whole makes an imposing bed.

The bed illustrated is made up mainly of Crotons, most useful plants, because of their beautiful foliage and that they delight in the hot summer weather. These plants are not hard to strike from cuttings. Mr. George Huster, who has had charge of the grounds for 22 years, by the way, tells me that contrary to the general way, he keeps the plants growing all winter, so that his young plants rooted the previous season are large enough for his bedding uses. Though the plants in this bed are mainly of one kind, there are numerous crotons. A bed of them is as pretty as any plant could make one.

The carpet bedding, a little of which is shown on the right of the picture, is a pretty feature of the grounds. The contents of each bed are different from the others. As a guide I will name what one contains: Center, *Madame Thibaut*, double pink geranium, edged with row of *Verschaffelti coleus*, and an outer edging or border of *Coleus Golden Bedder*.

Anyone visiting Philadelphia in August or September should not fail to visit the grounds of Girard College.

*Joseph Mehan.*

A writer in *The Garden*, London, says, one of the best double Lilacs is *Leon Simon*. A good double white with very large blossoms is *Madame Lemoine*, with a companion single variety *Madame Le-graye*, less vigorous however. *Souvenir de Louis Spath* is a richly colored variety.

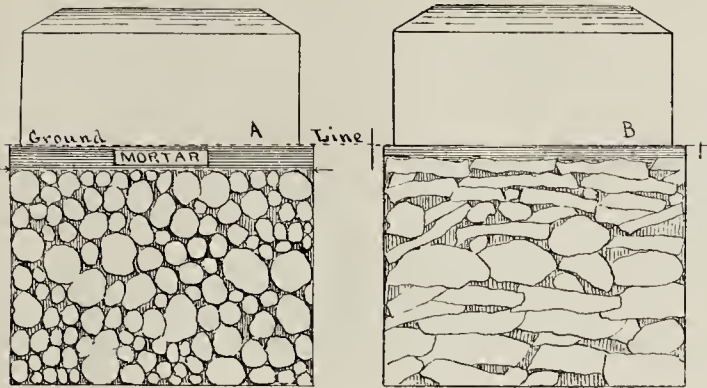
**Foundations.**

In the erection of monumental work there is no generally accepted standard for foundations. Modern cemeteries have adopted rules and regulations governing their construction, but they differ so widely that the builder in search of a standard, would doubtless be confused in attempting to discover any certain type that would meet all the requirements under all conditions.

Foundations are either good or bad; there are no medium grades. The object to be obtained in using them is to secure permanency and durability, hence any feature of them that is partially wrong must become wholly so; for a weak spot in the foundation will, in time, disintegrate the entire structure placed upon it. In this issue of the **PARK AND CEMETERY** we present our readers with a few ideas illustrating the different methods used in constructing foundations, together with the good and bad points of each.

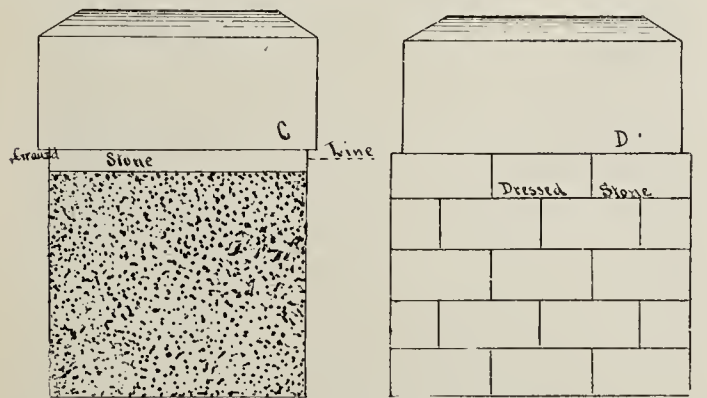


Figure A. represents a foundation used largely in country cemeteries, and is made of prairie or



cobble stones of various sizes, laid dry to within a few inches of the top—a level bed being obtained with a layer of mortar. Many masons will advocate this foundation as being all right, but it is not. In the construction of this foundation the stones are put in at random, and are merely bedded into place with a blow of a heavy hammer or tamper. It is impossible to place each stone so that it has bearing on the one below, and when the crushing weight of the monument is applied to the top there is bound to be more or less settling; the top bed of mortar cracks in this process and the result is a failure. But admitting that you can place the monument on without settling the foundation, the open spaces between the rocks are receptacles for water, and above the freezing point there is bound to be an upheaval and a settling that will throw the structure placed upon it out of plumb. The difficulty in using cement mortar with this foundation is to get it thoroughly mixed through all the open spaces between the stones, and if only a few of these open spaces are left it will in time affect the permanency of the entire foundation.

The same argument can be used with equal force against the foundation shown in fig. B., which is constructed of random quarry stone of various

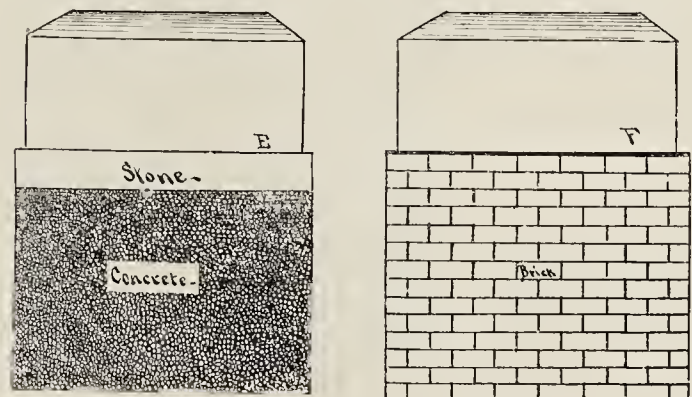


sizes. These two foundations have been used largely in the erection of monumental work and they have proven failures and must be abandoned.

In fig. C. a foundation is shown that is faulty in construction rather than in materials. The cut shows

the base larger than the top of foundation and slightly elevated above the grade line. A case recently occurred in one of the Chicago cemeteries, in which a foundation of this kind was used and it caused an unlimited amount of annoyance. After setting the monument the earth was raised in a mound around the base, to close the aperture or opening underneath; each rain settled and washed away this earth, leaving an unsightly space. This operation was repeated several times but the earth could not be kept mounded up and it finally resulted in compelling the lot owner to raise the entire grade of his lot to the base line of the monument. Oftentimes this would seriously affect the beauty of a cemetery lot, as a couple of inches added to the grade of a lot after it has reached a proper grade would destroy its beauty entirely.

In considering a foundation, cost must necessarily receive attention, yet the small difference between the perfect and imperfect construction of the same should never stand as a factor against the



good. Under the heading of perfect foundations we would class 1st.: dressed stone laid in cement mortar; 2nd.: concrete with stone top; 3rd.: vitrified brick with cement mortar; 4th.: stone piers and concrete filling.

To choose between these would be very difficult, for if properly constructed they will bear with perfect safety any load that can be placed upon them, and the adoption of either would depend largely on the convenience in securing the material and handling.

In the dressed stone, fig. D., care should be taken in the bedding and joints, and the latter should be broken regularly as shown in the cut. The concrete foundation, fig. E., is given a stone top for the reason that in handling a heavy base on it, if the concrete has not set perfectly hard it would be apt to crumble and crack were it not so protected. The concrete is made by crushing stone so it will pass through a two inch ring, and the foundation is commenced by placing a layer of it about six inches deep in bottom of foundation. Then take 1 part water lime cement and 1 part sand,



mix dry and then add enough water to reduce it to the consistency of very thin mortar. Slush the broken stone full of this until it rises freely through the top, and repeat the operation until you reach a point that will be filled by placing on the top stone covering. Bed this stone in mortar and allow it to stand at least 2 days before placing the monument on it and the foundation will be found perfect and reliable.

In the brick foundation, fig. F., a good quality of vitrified paving brick should be secured, and each course laid in cement mortar, care being taken to break the joints as shown in cut. Put a heavy bed of mortar on the top and let it thoroughly set before using.

In fig. G. is shown a method of constructing a foundation so as to span a grave, or soil, that has been disturbed through digging or excavation. Sometimes it happens that a grave has been placed in a position that will not allow a foundation to be put down straight, of sufficient size to take the base of the projected monument. This can be overcome by building piers in the solid earth on either side of the grave, or base ground, and after passing the height of the burial box a solid stone is put across sufficient to span the space. The intervening space above is then filled with concrete. As a general rule foundations should be made about an inch larger than the ground plan of base.

Soils vary considerably in their bearing power, and a very good method of establishing a fine foundation in loose soil is to employ for a footing some coarse sand or clean gravel firmly compacted. Too much attention cannot be paid to the feature of good foundations and their general adoption will be the work of the next few years.

*C. T. Stickle.*

#### Island Cemetery Receiving Tomb, Newport, R. I.

The accompanying illustrations represent the new Receiving Tomb of the Island Cemetery, Newport, R. I. It contains 62 catacombs and is 43 ft. long by 32 ft. wide. It is built of local granite



ISLAND CEMETERY RECEIVING TOMB, NEWPORT, R. I.

with interior walls of brick and blue stone. The arched ceiling and walls of main corridor are of white enamelled brick and the catacombs have white marble doors. The floors of the entire structure are of Portland cement concrete.

The system of drainage and ventilation is thorough. Each catacomb is drained independently by lead pipes, as well as the floor of the main corridor. The ventilation is secured by a 6 inch air space between the outer and inner walls to which each catacomb is connected by a register, and the current of air is admitted through the outer walls, passing all around the building and issuing through the ventilator over the arch. The interior is ventilated through perforated iron doors.

The style is Grecian of the Doric order, and the entire structure sets upon a granite platform. On the front is a porch supported by eight granite fluted Doric columns which gives a classic and imposing appearance to the structure.

Great care has been exercised in the construction and supervision of this tomb, as much to ensure permanence as to secure a receiving vault having all



INTERIOR VIEW.



the advantages and improvements which our present knowledge suggests as proper and desirable for such cemetery requirements. The cost of the structure was eight thousand dollars, and the Cemetery Company paid two thousand dollars for the site.

It was erected after the design of Mr. Edwin Wilbur, Architect, of Newport, R. I., by Mr. William Gosling, contractor.

#### Constitutional Right to Construct Highways Through Cemeteries.

An exceedingly important question has been passed upon by the supreme court of Michigan in the case of Woodmere Cemetery v. Roulo. The highway commissioner ordered a highway to be opened along the north side of the cemetery, condemning therefor a strip of land which was not in use for burial purposes at the time, but which had been purchased and was being held with a view to such use. This was resisted on the ground that the cemetery was owned by a corporation formed under a provision of law that "No streets, highways, railways, sewers or canals shall be opened or constructed through the grounds of such corporation, without the assent of the board of directors, granted at a meeting of such board, called for the purpose of considering the propriety of granting such assent." The court decides in favor of the highway. It says that we are not to presume that the legislature intended to barter away sovereign rights when by general law it provided that lands held by cemetery associations should not be taken for highways without consent of their board of directors. An attempt to do so would be futile. Therefore, the provision under consideration, if of any validity whatever, must be considered as no more than an assurance of immunity from unnecessary interference by local officers, by precluding their action, without the consent of the cemetery associations, until the legislative will should be manifested by further legislation. The legislature could, when it should see fit, lay out a highway across these grounds by a special act, without passing a general law providing for state roads through all cemeteries. This is the effect to be given the act of 1893 providing for the opening of a public street through the above mentioned cemetery.

The wonderful East Indian statues and temples cut from the solid boulders and stratified rock are duplicated, if not excelled, by the Afghans, says Prof. J. A. Gay, in one of his recent lectures on the far east. He tells of a stone statue of a god which he saw at Bamian, near the Russian frontier, which was one of a score, but was the giant of the lot, being one hundred and seventy-three feet in height

and large in proportion. It was used as a storehouse for grain, and at that time contained over two thousand bushels.

#### Confederate Monument, Chicago.

A most important monument, in point of public interest, was dedicated on Decoration Day this year in Chicago. It was that erected to the memory of the Confederate prisoners of war, who died in Camp Douglas, Chicago, and were buried in Oakwoods Cemetery of that city. All over the country attention had been drawn to this on account of the conflicting sentiments expressed, but the decided manner in which Chicago took it up, and made of it an event long to be remembered, and of a possible immense good to the country, settled the question and in a characteristic manner. The decorations about this monument were most profuse.



CONFEDERATE MONUMENT, OAKWOODS CEMETERY, CHICAGO. The floral wealth of the South was freely drawn upon, and several carloads of palmettos, palms, magnolia blossoms, jessamine and various flowers and wreaths, were received from the warm hearted Southern people and placed about the monument or distributed over the graves of blue and gray alike.

The four guns which stand guard at the corners of the monument, and which had done deadly service on both sides, having been captured by the Confederates at Chickamauga and retaken by the Federates at Nashville, were spiked and silenced forever. The ceremony was a memorable occasion, fraught with many possibilities for future good.

The monument, herewith illustrated, stands something over thirty-six feet high. It is constructed of Georgia granite, furnished by the Southern Granite Co., of Atlanta, Ga. The bottom base is fifteen feet six inches square. The die six feet square by three feet high. On top of a battlement crowned shaft stands a heroic figure of a Confederate infantryman in a pose suggesting the resignation of a brave man to the inevitable.



## Greenhouses.—How to Build. VI.

Fig. 8 and Fig. 9 show two forms of outside wall when no gutter is used. Fig. 8 is the simpler but the very wide plate (5) used is likely to check and warp and the water is apt to get into the wall.

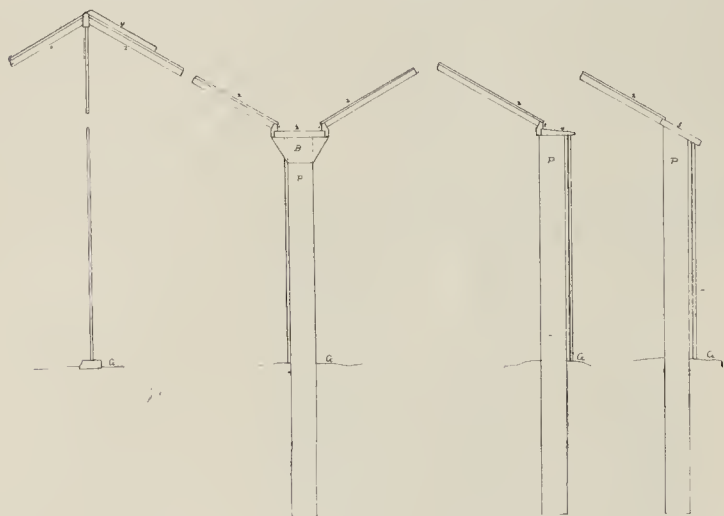


FIG. 10.

FIG. 9.

FIG. 8.

Strips should be screwed across the under side after it is joined together, to prevent warping as far as possible. Both plates, (4 and 5) are attached directly to the tops of the posts which must be cut off true to receive them. The posts can be easiest cut off true by jointing two 16 foot boards true on the edges and tacking them to opposite sides of the posts, so that their upper sides are in the true line of the cut. The flat of the saw is laid against the upper edge of these boards and the cut follows the line of their edges.

In Figs. 7, 8 and 9, also Fig. 10, (2) is a portion of the sash bar showing its attachment.

Fig. 10 shows the inside wall and peak of the roof, the latter supported by 1 inch iron pipe. (V) is the ventilator, hinged to the ridge piece and resting, when closed, upon the upper part of the sash bars.

The inner wall is the same as the outside wall with gutter, (Fig. 7,) except that the No. 1 sill is used on each side, the brackets are 4 inches longer on top and project from each side of post, and the paper and siding is omitted, one thickness of ship lap only being used.

Great care must be taken to keep the upper angles of all sills and wall plates, (if Fig. 8 wall is used) or wall plate sills at the same absolute height without regard to irregularities in the ground. That is, if a straight edge be laid across from sill to sill, (or sill to plate as may be,) at right angles to the length of the house, it should show perfectly level. Of course, as before shown, all sills will have a uniform drop to the south.

Figure 11 shows the peak of the roof. The

ridge piece (7) is worked from 2x4 inch stuff and runs the length of the house, supported at intervals as explained before by 1 inch iron pipe (10). Between the pipe and the wooden ridge is the iron washer (8). The washer is held in place by the lag screw (9) passing through it and into the ridge. The head of the lag screw is inside the pipe, (which is cut away in the cut to show it), and prevents the pipe from being forced out of place. The upper part of the ridge is beveled from the middle each way to be continuous with slope of the bars. The bars (5) are mitered to fit snugly against the sides of the ridge, the upper side of the tongue (4) in exact line with the bevel of the ridge. The glass (1) rests on shoulders on the bars and projects a short distance into a groove cut in the ridge. A longitudinal groove (6) is cut in the bars to carry any moisture collecting on the inside of roof down to the sill.

A cross section of the sash bar with parts bear-

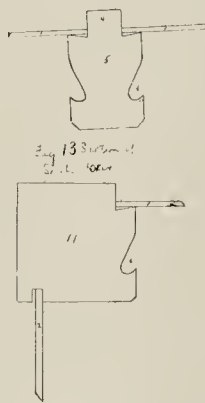


FIG. 14.

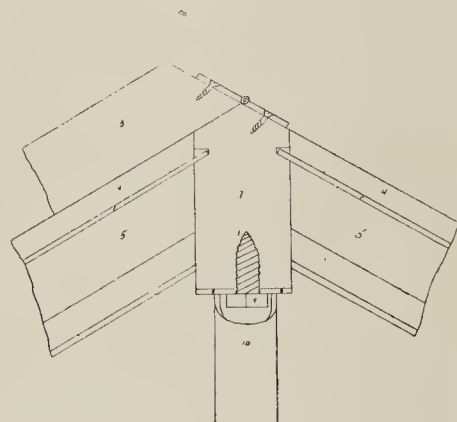


FIG. 11.

ing corresponding numbers is shown in Fig. 13.

The ventilator (3) is hinged to the ridge, as shown, which is perhaps the best arrangement for a plant house. In Fig. 2 in a former paper a wider ridge piece is shown, projecting above the roof and carrying a cap, the ventilator being hinged below. This is more used in forcing houses.

The pieces to form the ridge should be gotten approximately into place and being fitted for halved joints should be spliced in the same careful manner as the gutter parts.

Willis N. Rudd.

(To be Continued.)

The Board of Trustees of Elmwood Cemetery, Detroit, Mich., has issued a very handsome brochure giving the history of the cemetery which was organized in 1846, and incorporated in 1849; a report of Mr. F. L. Olmsted dated 1891, embodying improvements; Rules and Regulations and the Act of Incorporation. It is printed on the old style paper, contains some thirteen full page half tone engravings, and is altogether a handsome specimen of pamphlet production.



◁ PARK NOTES. ▷

The commissioners of the Minneapolis parks have decided to establish a limited zoological department in Minnehaha park.

\* \* \*

The city of Santa Cruz, Cal., has been bequeathed some 154 acres on Laveaga Heights for a public park by the deceased owner whose name the property bears.

\* \* \*

Mayor John C. Atkinson, of Henderson, Ky., at the time of resigning the office last month, presented the city with a piece of property for the purpose of a public park.

\* \* \*

Beaver Park, Albany, N. Y., has cost some \$449,000 of which \$105,000 has been for construction. According to the mayor's message it will cost a further \$200,000 to complete it.

\* \* \*

The contract for building the propagating houses at Schenley and Highland parks, Pittsburgh, Pa., has been awarded to Thomas Weathereds Sons, New York city, at a cost of \$40,000.

\* \* \*

The total receipts for the year ending March 1st, 1895, of the park board of St. Paul, Minn., was \$89,222.08, which with the previous balance gave \$162,366.29. The total disbursements were \$135,657.09, leaving a balance of \$26,709.20.

\* \* \*

A notable and useful feature of park adornment is the fountain, and looking over the country it is a feature showing much neglect. Moreover it is one that invites the consideration of liberal and public spirited citizens, for the fountain is an excellent memorial.

\* \* \*

A project is on foot, originating with R. E. Lee Camp, Confederate Veterans, Richmond, Va., to induce congress to create a National Military park about Appomattox Court House, where Grant and Lee met and consummated the surrender of the southern army.

\* \* \*

The Essex county, N. J., Park Commissioners have selected John Bogart, of New York, and J. S. Barrett, of Bergen county, to lay out the new park to be made under the act authorising an expenditure of \$2,500,000. Frederick Law Olmsted is to be retained as consulting engineer.

\* \* \*

The Illinois legislature has passed the bill for the extension of Lincoln park, Chicago. It adds to the responsibilities of the commissioners by requiring the utmost care in expenditures. It is within the possibilities that many miles of the lake shore north will eventually become a public park.

\* \* \*

Frederick Mac Monnies has a large amount of work on hand for Prospect park, Brooklyn. A fine Quadriga will surmount the soldiers' memorial arch, and side pieces containing equestrian statues of Grant and Lincoln will be striking works of art. Four colossal bronze eagles will complete the caps of the four columns at these entrance gates.

\* \* \*

Omaha, Neb., has a park area of 543½ acres, valued at \$1,267,000. In 1894 there was expended on the park system \$118,865. A complete statement of the purchase fund to January 1st, 1895 shows an outlay of \$425,393.92, and the park maintenance and improvement account to the same date shows an expenditure of \$265,444.31, and this dates from 1889 90.

\* \* \*

A magnificent scheme for beautifying the lake front of Chi-

cago, is now under consideration by its leading men. D. H. Burnham, of World's Fair fame, and C. B. Atwood, the architect of the beautiful Art Palace and other structures, have proposed plans, the scope of which, if carried out, and it is in the hands of the most prominent citizens of ability and resources, will make Chicago by a long way, the greatest park city of the world.

\* \* \*

Plans have been prepared for extensive and costly improvements at Schenley and Highland parks, Pittsburgh, Pa. Among them are a zoological building 500 feet long, built of gray sandstone, to cost, with surroundings, \$100,000; a new bridge opposite the casino, near which will be erected the grand monument to Mrs. Schenley. There will also be constructed a refectory and large shelter buildings as well as a lookout tower. In Highland park a handsome entrance is to be erected and several additions made in the way of buildings, etc.

\* \* \*

Thirty thousand dollars has been appropriated at the annual town meeting of Swampscott, Mass., for the purpose of beautifying the sea beaches of that resort. It is proposed to clear the beaches of unsightly buildings, make a certain portion a fisherman's landing and to build suitable fish houses, owned by the public. The fish houses are considered to add picturesqueness to the place. The appropriation is conditional on a sum of \$15,000 being secured from the Metropolitan Park Commission, or from any other source. It is said the latter amount is assured.

\* \* \*

The following statistics concerning English parks and certain large manufacturing municipalities are of interest:

	Population.	Density of population per acre.	Acreage of Parks.	Annual expenditures on Libraries.
Birmingham	478,000	39.1	360	\$ 82,681
Manchester	505,000	40.0	215	102,196
Liverpool	517,980	98.6	600	76,473
Glasgow	656,946	56.9	700	43,798
Bradford	202,975	20.3	216	28,308
Leeds	367,000	17.7	663	44,990

\* \* \*

Considerable improvement might be effected at the small country towns if the railroads touching them would pay some attention to the appearance of their depots and grounds. This could be done at comparatively small expense and would react to the advantage of the companies. The Chicago & Northwestern Railroad is carrying out some excellent park-like improvements about their depot at South Milwaukee, a work which could be carried on elsewhere with excellent results. Many of the leading railroads employ landscape gardeners for improving their station grounds.

\* \* \*

A new park is under way for Menominee, Mich.—Albuquerque, N. M., has awoke to the necessity of park improvement, a hitherto neglected work.—Hinton, W. Va., is at work on a city park.—The bill for a park between 20th and 30th Sts. and west of Ninth Avenue, New York city has been approved.—The Seventeenth ward of Albany, N. Y., is to have a park.—A project is on foot to make Stony Point, on the Hudson, the site of "Mad Anthony" Wayne's successful capture of the British forts in 1779, a public park.—One thousand dollars has been subscribed towards creating a public park in the central part of Oldtown, Me.—Neosho Falls, Kan., has acquired the fair grounds for a park, giving the town one of the finest parks in the state.—Bonds to the amount of \$10,000 will be issued by the Newburgh, N. Y., council for the further improvement of Downing park.—Peabody, Mass., is practically committed to a park system, some valuable bequests depending on official action.



## CEMETERY NOTES.

Work has commenced on a Chapel and Receiving Vault for Union Cemetery, Westmoreland, N. Y.

\* \* \*

There are twenty three cemeteries in Paris, France. After Pere la Chaise the most important are Mont Marte and Mont Parnasse.

\* \* \*

The mausoleum planned to be built by the will of Mrs. Cornelia Francis Coster, in Woodlawn Cemetery, New York, and for which she left a large fortune, may be erected, objections to the probate of the will having been withdrawn.

\* \* \*

A simple monument has been erected over the unmarked grave of Chief Justice Salmon P. Chase, in Spring Grove Cemetery, Cincinnati, O., the gift of friends. It bears this inscription: Salmon P. Chase, Senator, Governor, Secretary of Treasury, and Chief Justice. 1808—1873.

\* \* \*

The trustees under the will of the late Emeline R. Carpenter, have turned over to the Foxboro Cemetery Corporation, Dedham, Mass., the new Carpenter memorial chapel, just completed in Rock Hill Cemetery. The total cost of chapel and furniture was \$3748.10, and a fund was also left for care of the burial lot.

\* \* \*

The cemetery of Saco, Maine, has suffered considerably from the petty thieving of flowers and plants from its grounds, and at the last meeting of the city council, an ordinance was passed authorizing the city clerk to reward any one who would cause the arrest and conviction of any person for stealing or destroying plants in either public or private grounds.

\* \* \*

While resetting grave stones in the Reformed Church yard, Port Richmond N. J., a slab of brown stone was unearthed which proved to be in memory of, "Hier Leige Johannes Veghre Geboor," who was born "Janery, 1719," and who died "Aperil 1748," 117 years ago. Beside the slab was found another, not as yet deciphered, but which is believed to have been erected in memory of his wife.

\* \* \*

Decoration Day was observed throughout the country with the customary exercises, and with quite as much devotion as usual. In some localities, more than ordinary interest was excited owing to special events, so that cemetery officials have had their hands full during the month, repairing damages and bringing their properties back again to the freshness and cleanliness necessary to proper appearance. Before and after Decoration Day the cemetery superintendent finds his busiest time, in the first place to prepare, and afterwards to repair—matters of anxiety in both cases.

\* \* \*

In speaking of the Rosemary at Funerals *Meehan's Monthly* for June says: It was the custom in the rural parts of England, and probably is yet to a great extent, for every attendant at a funeral, to carry a sprig of rosemary, which is thrown in the grave when the last look is taken. Mrs. Seliger states that this custom is also followed in Germany, and that the rosemary is grown as a pot plant in many windows, and thus furnishes many a sprig for the mournful occasions. It is believed that the custom originated in a belief that Rosemary had the power of aiding the departed soul in its struggle against evil spirits.

The oldest cemetery in Salisbury, Mass., is near the State line, and the next oldest is at East Salisbury proper, which is upwards of 200 years old. In it lie the remains of four of the ministers of the town. The Rev. Dr. William Worcester, the ancestor of the well known Worcesters now living in Massachusetts, who died in 1662. No memorial stone marks his grave. The second minister was Rev. Dr. Wheelwright, equally eminent, and the ancestor of Dr. Wheelwright, formerly secretary of the State board of charities, whose grave is also unmarked by any monument. The third minister was Rev. Caleb Cushing, the grandfather of Hon. Caleb Cushing and John and William Cushing, of Newburyport. His grave is not marked by any monument. The old cemetery has been newly abandoned as a burial place and the new cemetery near the Beach takes its place for burial purposes.

\* \* \*

There are eighty-three National Cemeteries scattered over the country, containing some 330,700 soldiers' remains. It was the second year of the war that Congress instituted such resting places for its soldier dead and in the following year cemeteries were dedicated at Chattanooga, Stone River and Gettysburg. Arlington was laid out in 1864 and Antietam in 1865. Following the general plan of 1865, seventeen cemeteries were established in Virginia, seven in Tennessee, six in Kentucky, four in North Carolina, four in Louisiana, three in Mississippi, three in Maryland, two in South Carolina, two in Georgia and two in District of Columbia. In the North and West, four exist in Illinois, three in Missouri, two in Indiana, one in Iowa, two in Pennsylvania, two in New York and two in New Jersey. Besides these there are several smaller plots, and many lots owned by government in other cemeteries.

\* \* \*

Cornelius and William K. Vanderbilt have deeded the old vault and lot of the Vanderbilt family in the Moravian Cemetery, Staten Island Church corporation, on condition that it shall always remain the property of the church, and the ground be laid out in grass and beds of flowers. The bodies, about 20 in number, which were in the vault, were removed some months ago, some of them being placed in the mausoleum of William H. Vanderbilt on the hill, and the remainder interred in lots belonging to the various branches of the family of which they had been members. It is said, the late owners agree to remove the iron fence, the stone and iron forming the vault, and the remarkable structure which surmounts the vault and which upholds a figure which, as an exchange says, might pass for a copy of pretty much anything. The Moravian Cemetery will be greatly improved by the contemplated change.

\* \* \*

New rules have been adopted in connection with the Hudson County Catholic Cemetery, New Jersey, in line with modern ideas. Among them are: There shall be no fencing, coping or enclosure about a grave. Boxes, shells, toys, etc., must not be placed on graves. None but stone or durable metallic headboards will be allowed. Wooden tablets or crosses are prohibited. Metal monuments will not be allowed, except in bronze. No bodies will be taken from the receiving vault on Sundays, holy days or holidays. No smoking will be allowed in the cemetery. In the book of rules an earnest appeal for simplicity in funerals is made, and the following speaks for itself: Another abuse, only too common, is the Sunday funeral. Unless imperative necessity obliges, as in contagious diseases and in times of epidemics, funerals should not be on Sundays. Public sentiment is opposed to them.

"In the future, no applications will be received for interments on Sunday forenoon, and it is desired that, as far as possible, no interments take place on that day."



## ≡ CREMATION. ≡

Nearly fifteen hundred bodies have been cremated at Fresh Pond, N. Y., German citizens leading in numbers, half the total being of that nationality. The United States takes next place with nearly five hundred bodies. Englishmen come next with some forty odd to their credit. Then in order comes Switzerland, Austria, France, Ireland, Hungary, Italy, Denmark, Scotland, Cuba, Holland, Belgium, India, Sweden and Norway, etc. Of the whole number about two-thirds are men and boys.

\* \* \*

Cremation services have been officially declared by Masonic authority not to be Christian burial. The question that determined this decision arose over the burial of the late Charles H. Reisser, of Philadelphia. Mr. Reisser's wish was to be cremated, and after his death his family decided to follow his wishes. He was a Mason, a member of Rising Star Lodge, Oriental chapter, and of Kadosh commandery. These organizations were invited to take part in the funeral, but Judge Arnold, grand master of Pennsylvania, rendered a decision that services at a cremation were not Christian burial under Masonic law. The original intention was therefore abandoned and the funeral took place and the Masonic organization attended in a body and performed Masonic rites.

\* \* \*

In speaking of what to do with the ashes of the dead after cremation, Dean Hodges, in a contribution to the *Urn*, says: "Or better still, there might be a renewal of the good old custom of laying the dead away in the churches. Cremation would make that possible. Heaven and earth would thus seem close together. There would be no more removals of the relics of the dead miles away out of our sight, and that devotion to the dead which at present prompts the erection of great piles of carved stone beside a grave, effecting no good purpose whatsoever, would lead to the enriching and beautifying of the House of God, so that all the worshippers would be uplifted."

## ≡ Correspondence. ≡

Camden, N. J., May, 27, 1895.

*Editor Park and Cemetery.*

DEAR SIR:—In reply to "Enquirer" will say if he will look up the laws governing cemeteries in N. J., he will find that no cemetery can tax a lot holder unless he or she may contribute toward improvements at their own option. I do think that it would be a good thing to have a law compelling all cemeteries to lay aside say 6 per cent of sales and use it for improvements. This would do away with the sad neglect of our so-called

"Grave Yard." Should the company object to the above amount let them add it to every sale allowing according to size of lot or single grave.

GEO. E. RHEDEMEYER.

\* \* \*

### Shall we Open our Cemeteries for Sunday Driving?

*Editor Park and Cemetery:*

DEAR SIR:—The above is a question I should like to see answered by Cemetery superintendents, and also by PARK AND CEMETERY. The writer believes that cemeteries should close their gates except to pedestrians. Sunday is a day when owners of lots visit their grounds to pay loving tributes to the dead, and should, to a great degree, have the cemetery to themselves; quietude should certainly reign supreme one day in seven.

G. S.

The Sabbath should be observed in cemeteries by restricting admission to lot owners, or to others by obtaining tickets of admission. [EDS.]

## CEMETERY REPORTS.

At the annual meeting of the Woodlawn Cemetery Association of Canandaigua, N. Y., the secretary's report showed total receipts since 1884, to be \$37,043.04, and for the past year, \$2,315.49. The total disbursements since organization amount to \$46,738.34, and for the past year, \$2,310.79, leaving a present indebtedness of \$9,700.

\* \* \*

At the annual meeting of the lot holders of Oak Hill Cemetery, Washington, D. C., the report for the year ending April 30th., showed that 265 interments had been made during the year. Under the rule that all revenue above actual expenses shall be used in improving the property, the interest of a sum which has reached \$157,000 is expended for that purpose.

\* \* \*

At the annual meeting of the Crown Hill Cemetery, Indianapolis, Ind., the secretary reported for the year, 848 burials in lots and 431 in single graves, a total of 1,279. The total of burials in the cemetery up to June 1, 1895, is 22,262. Receipts from sales of lots in 1895 were \$17,124; the expenditures for the year were \$30,000. The perpetual care fund now amounts to \$153,286. The Board places the amount which should be accumulated for perpetual care at \$500,000.

\* \* \*

At the 46th annual meeting of the Easton Cemetery Company, Easton, Pa., the Treasurer reported a cash balance of \$1,925.55 on hand from last year. Other receipts \$1,834.40 from the sale of lots; \$1,308.22 interest; \$2,592.50 from bequests and deposits; \$5,730.30 collections for work done, and \$2,350.70 from mortgages that were repaid, making total receipts amount to \$15,741.67. Total expenses were \$10,853.25, which included \$1,250 paid for a tract of land purchased. The total amount of the bequest and deposit fund is \$22,669.50, and the total amount invested on bond and mortgage is \$27,950. The president, Dr. Green enters upon his 46th year in that office.

### Association of American Cemetery Superintendents.

O. C. SIMONDS, "Graceland," Chicago, President.

G. W. CREESY, "Harmony Grove," Salem, Mass., Vice-President.

F. EURICH, Woodlawn, Toledo, O., Secretary and Treasurer

The Ninth Annual Convention will be held at Richmond, Va., September 18, 19, and 20, 1895. A number of interesting papers have been promised.



### Publishers' Department.

Park Commissioners and Cemetery trustees are requested to send us copies of their reports.

Photographs and descriptive sketches of interesting features in parks and cemeteries are solicited from our readers.

PARK AND CEMETERY wants the names of every park and cemetery official or employee who would be likely to be interested in this paper. To the many subscribers who have sent in such list of names, we return our thanks. There are many more that we should hear from.

Subscribers are again reminded that we want brief notes on any feature of park or cemetery work that will be of general interest. PARK AND CEMETERY is the only publication of its class and earnestly solicits the co-operation of subscribers in making it a help to all identified with such work.

Rev. John F. Corcoran of New Haven, Ct., suggests having a department in PARK AND CEMETERY devoted to "Cemetery Accounting" in which forms used in every day business may be published. The suggestion is a good one and will receive attention.

Mr. Joseph Meehan of Philadelphia, whose name is familiar to our readers is now in Europe. While abroad he will gather notes for PARK AND CEMETERY.

Contributions have been received from B. Chaffer, Syracuse, N. Y., H. L. Burdick, Tomah, Wis., and J. C. Craig, Omaha, Neb.

NOTICE TO SUBSCRIBERS. If this notice is marked with a blue pencil it indicates that your subscription to PARK AND CEMETERY has expired and a renewal of same is solicited.

RECEIVED.

The annual report of the Board of Park Commissioners, Omaha, Neb., for 1894. Including recapitulation of Park affairs since the organization of the Park Board in 1889. Contains several half tone illustrations.

Fourth Annual Report of the Board of Park Commissioners of the City of St. Paul, Minn., March 1, 1894, to March 1, 1895. With maps and half tone illustrations.

Act of Incorporation, By-Laws, Rules and Regulations, etc., Grove Hill Cemetery, Shelbyville, Ky.

Annual report, Edgewood Cemetery, Nashua, N. H., for 1894.

Map and views of Sleepy Hollow Cemetery, Tarrytown, N. Y.

Bulletin 90, April 1895. Cornell University Agricultural Experiment Station. Horticultural Division. The China Asters with remarks upon flower beds. On the subject of China Asters this pamphlet contains information useful and unquestionably reliable, and is an excellent guide both to the selection of the seed and cultivation of the plant.

\* \*

It is understood that arrangements for the ninth annual convention of the Association of American Cemetery Superintendents are progressing satisfactorily. A number of excellent papers will be read.

Mr. J. R. Harper of Richmond, Va., where the convention is to be held is endeavoring to interest southern cemetery officials. Superintendents desirous of becoming members of the association should address, Mr. Frank Eurich, secretary, Woodlawn Cemetery, Toledo, O.

The Lynn, Mass., *Item* compliments Supt. Wm. Stone on the beautiful floral display and well kept condition of Pine Grove cemetery. Two rock gardens and a tastefully arranged lily pond are attractive features. An ornamental bed at the entrance consists of a large maltese cross with an hour glass in the center. On the arms of the cross are appropriate words from Longfellow.

A writer in *The May Flower* recommends using moth balls to exterminate moles. The balls should be partially covered with tin foil as a preservative and placed where the moles are likely to travel.

Randalls Iron solvent for removing iron rust and other stains from granite is said to be very effective.

Ellwanger & Barry call especial attention this month to the Wichuraiana rose. It is peculiarly adapted to cemetery planting and has already been introduced in many places.

The address of the Delamater Iron Works is now 467 West Broadway, New York City, instead of 87 South 5th avenue as heretofore.

The Belle City, M'fg. Co., of Racine, Wis., whose ad. appears in another column, are putting specials wheel with tires 2½ inches wide, on their combination Water and Truck carts, when preferred.

*American Gardening* will celebrate the month of Roses by a special edition devoted to Roses, profusely illustrated. The valuable issue will be supplemented by a lithograph in 11 colors of one of the new roses. A copy will be mailed to any of the readers of PARK AND CEMETERY who may apply for it by addressing: *American Gardening*, P. O. Box 1697, New York.

### PRESS NOTICES.

For the past four years PARK AND CEMETERY has proved a welcome visitor to all engaged in cemetery work, under the name of THE MODERN CEMETERY, and has been the acknowledged medium of disseminating progressive ideas in cemetery management. At the present time park and cemetery work are so closely combined that the name of this publication indicates its mission, and will prove a source of valuable information to park commissioners as well as cemetery officials.—*Daily Register*, Newburgh, N. Y.

PARK AND CEMETERY is a magazine which certainly would be a boon to all interested in this especial work as well as to any one who is a lover of nature.—Brighton, Ill., *News*.

I get many useful suggestions from its pages.

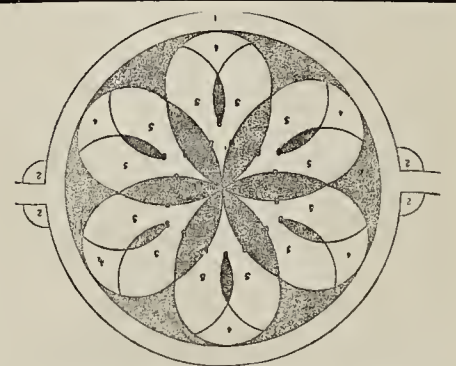
C. A. Noble, Supt.  
CATSKILL RURAL CEMETERY,  
Catskill, N. Y.

I am glad you have made the change from *The Modern Cemetery* to PARK AND CEMETERY, it is a great improvement.

C. S. Bell, Supt.  
Lexington Cemetery,  
Lexington, Ky.

I like your new name, and am much pleased with contents. Many items of interest and much information is to be gained by its perusal.

Henry Thompson, Supt.  
Mount Pleasant Cemetery,  
Toronto, Ont.



### Ornamental Gardening.

## SOLLY'S BOOK OF PLANS

Contains over 100 Designs of

### Carpet and Ornamental Flower Beds.

Each design is drawn on a scale and is accompanied by a key, showing what plants should be used. A valuable book for cemetery superintendents and landscape architects, Mr. Solly, the author, is a landscape gardener, with 36 years' experience. The book is 8x10 inches, substantially bound. Retail price, \$3.00; with PARK AND CEMETERY for one year, \$3.50.

R. J. HAIGHT, Publisher,  
334 Dearborn St., Chicago.



# PARK AND CEMETERY.

FORMERLY THE MODERN CEMETERY.

A Monthly Journal Devoted to Parks and Cemeteries.

R. J. HAIGHT, Publisher,  
334 Dearborn Street, CHICAGO.

Subscription \$1.00 a Year in Advance. Foreign Subscription \$1.25

VOL. V. CHICAGO, JULY, 1895. No. 5.

## CONTENTS.

EDITORIAL.....	73
A FEW WORDS FROM A LANDSCAPE GARDENER.....	74
*BOTANIC GARDEN, BUFFALO, N. Y.....	76
NATURE VERSUS ART.....	77
*A GREENLAND CEMETERY.....	78
*THE BEDDING OF MONUMENTAL WORK.....	79
KNOWING HOW.....	80
*ENTRANCE TO FOREST HILL CEMETERY, FREDONIA, NEW YORK.....	81
PROPAGATING RARE, HARDY PERENNIALS.....	81
*GREENHOUSES—HOW TO BUILD. VII.....	82
*A FLOWER BED AT GIRARD COLLEGE, PHILA.....	83
*SOLDIER'S MEMORIAL, OAKWOOD CEMETERY, SYRACUSE, N. Y.—TAM-NA URICH.....	84
NINTH ANNUAL CONVENTION, A. A. C. S.....	85
POINTERS FOR CEMETERY OFFICIALS.....	86
PARK NOTES.....	87
CEMETERY NOTES.....	88
CORRESPONDENCE.....	89
PUBLISHER'S DEPARTMENT.....	90

\*Illustrated.

ADVOCATES of cremation in a Western city, who are contemplating the erection of a crematory, have adopted a novel plan for interesting stockholders, which if successful, will have fulfilled the two-fold purpose of securing a crematory and making converts to the cause. Each holder of one share of stock becomes entitled to incineration in due course. This may be like some insurance policies. However, in the event of cremation becoming popular, the shareholders hope to realize dividends before surrendering to the inevitable.

IN regard to cremation, public sentiment is undoubtedly growing in its favor, and hitherto pronounced opponents are, slowly, it is true, modifying their antagonism. To those who can divert their minds from the customs of burial practiced by Christian people for so many centuries, the idea of cremation is not objectionable, and there are many arguments that can be arrayed in favor of such a disposition of our dead. In the leading cemeteries of several of the prominent cities and towns crematories have been introduced, and indications point

to a time coming when they will form an essential feature of every modern cemetery.

AN ordinance creating an Art Commission for the City of Baltimore was approved on June 10th last. By its provisions the Commission shall consist of the Mayor of the City, and seven others, respectively appointed by the Johns Hopkins University, the Maryland Historical Society, the Peabody Institute, the Maryland Institute for the Promotion of the Mechanic Arts, the Architectural Club of Baltimore, the Park Commission and the Charcoal Club, all to serve without pay. The ordinance enacts that no statue, fountain, arch or gateway, monument or memorials of any kind shall be erected, nor any change be made in those already existing, on any public property of the city, unless the matter shall have been approved by a majority of the commissioners and their report shall have been made to the city council. The commission shall at the mayor's request advise him on public buildings, bridges, etc.

SINCE the park movement is establishing itself quite generally over the country, it is exceptionally opportune to draw the attention of our smaller communities, not yet actively exercised in this direction, to the commercial aspect of the park question. There are to them two important sides to it: one the value of available property when no park is contemplated; the other the increased value of property when the park project is consummated. Experience distinctly dictates the advisability of all small towns taking advantage of their condition and securing or setting apart property for park purposes, while such is available and of comparatively small value. It is a fact that the moment it is generally known that the town is looking for a park site property values immediately rise, not only because the town wants it and is supposed to be able to pay a larger price for it, but because the value of property increases immensely about park sites everywhere. All cities and towns possessing parks can attest to this. Parks and park systems are being recognized today as an absolute necessity to the welfare of our larger cities, in a certain relative proportion they are also necessary to our smaller towns. But apart from the necessity, be it great or small, a park is a first-class investment for any community, for besides the hygienic aspects it pays the town and pays its citizens in a commercial sense.



**A Few Words From A Landscape Gardener. \***

Landscape gardening has for its object the preservation and development of out door beauty. I am glad of this opportunity to make a plea to engineers for the preservation of pleasing features in our landscape, because engineers and surveyors may exert so much influence in this direction. An enumeration of a few cases where unnecessary damage has been done will serve to introduce the subject. A piece of land was purchased for its fine trees, a rapid stream of water that flowed through it, and its proximity to Lake Michigan. A surveyor was engaged to determine the boundary of the tract. One of the lines which he ran for this purpose happened to pass through an old red cedar, which the axman did not hesitate to mutilate by cutting off half the branches. The tree had stood by itself and was exceptionally perfect. If its value as an ornamental tree could be given in dollars and cents (but this is a poor way of estimating the value of such a tree) it would be placed at fifty to one hundred dollars. Cutting the tree saved, perhaps, half an hour's time for the surveyor.

A few years since, in visiting a suburb of Chicago, which was fortunate enough to have a native forest growth, I was pleased to see that some of the original trees had been left along the roadside. An old oak with a thornapple tree that stood near, made a delightful group. There were also maples, lindens and hickories. When I saw this street a year or two later it had been improved (?). Its grade had been changed slightly and the fine old trees, in picturesque groups, were removed to make room for straight rows of little elms.

In one of the older cities in New York maples, elms and other trees were planted at an early day. They were placed from fifteen to twenty feet apart in rows on each side of the street. In a few years they crowded each other and shut out light and air from the houses, so the lower branches were cut off, and this process of trimming went on until in many cases the naked trunks, with ugly scars, where the branches had been removed, reached above the the second story windows. The upper branches spread across the street and over the houses, completely shading everything but the back yards.

In the outskirts of another city in New York lived a man whose grounds along the street boundary were fringed with native dogwoods, sumachs, Juneberries, witch hazel and sassafras, with here and there a wild grape or virgin's bower. In certain nooks golden rods and wild asters found homes, so that this group of native growth formed as in-

teresting a collection of foliage and flowers as could be found along the highways for miles. But one day the fever for improvement seized the owner of the land and he had all the "brush" grubbed out. He then hailed a passing acquaintance who, he knew, had some skill and good taste in planting, informing him that he wished to plant some shrubs and would like his assistance in selecting and arranging them. The man of taste replied that it would take ten years to produce an effect of shrubbery as good as that which had just been destroyed.

I mention trees and shrubs first because they are the materials with which a landscape gardener works—his paints. There are, however, other features over which the engineer has entire control—features which have much to do with the appearance and comfort of our surroundings, and hence come within range of the landscape gardener's criticism. These are grades, location of catch basins, sidewalks, curbing and frequently the location of the street itself. How often do we see profiles made with straight lines, frequently perfectly level, when a slight curve would save expense, keep the road bed drier, and improve the appearance of the street. Catch basins for receiving the surface water are very generally placed at the street intersections, making unnecessary steps at crossings and often obstructing these crossings with water during heavy rains. There will seldom be any difficulty in placing catch basins at some distance from corners, thus keeping the passageway for those on foot high and dry. Again, sidewalks are usually made to follow the grade of the roadway, when there is no real reason why they should do so, excepting the desire of the engineer to simplify his own work. In residence districts streets are usually sixty-six feet wide, thus leaving a space of six to ten feet in width for grass and trees between the road-bed and the sidewalk. Where entrance drives to private grounds are not desired, no harm comes from leaving the sidewalk one, two, or even three feet above the street grade. Such an arrangement would frequently save fine old trees and also the expense of regrading and planting residence grounds. The steeper slopes could be covered with hardy shrubs, which would give a pleasingly varied and homelike effect.

In one of the most desirable residence districts of Chicago the streets are nearly all macadamized. Stone curbing separates the macadam from the grass plat. I have just measured this curbing in many places and find it to project from six to fourteen inches above the adjacent surface of the roadway. In such localities, where driveways are constructed of gravel, broken stone or asphalt, curbstones are not only expensive and unsightly but worse than use-

\* By O. C. Simonds, in *The Technic*, '94, University of Michigan.



less. They are especially dangerous when horses become frightened and shy to one side or run away. They prevent rainwater and melting snow from running off from the road surface and soaking into the ground on each side to the great benefit of trees and grass. With a brick or wooden pavement the curbing is necessary but it should be kept low, a projection of two inches above the adjacent surface being sufficient.

Having, perhaps, spent enough time in criticism, let us consider what can be done to make a street attractive. We will assume that a pleasing variation in grade and proper drainage have been secured, and that, while the grade is an easy one, it has been placed so low as to do the least damage and be of greatest benefit to the property on each side. It is nearly always desirable to have residence lots somewhat higher than the street. The appearance is also improved by having the houses placed some distance back from the lot line. While it is by no means essential that all houses should be placed the same distance from the street line, it is a wise measure to have a line established in front of which no building can be erected. Houses can sometimes be built at various distances back of this line with good effect. When the grade is properly taken care of and the houses correctly placed, the planting can be commenced. Care should be taken not to plant in such a way as to keep sunlight out of the windows, and some open spaces along the street give to it a better appearance than it it would have in continuous shade. The planting of shrubs and vines about verandas and along the blank walls of buildings, will help to make them attractive and homelike, but this is a matter for individual taste. The street planting ought to be designed with a view to its effect as a whole. The United States is wonderfully rich in its variety of trees and shrubs, very few of which are unattractive or objectionable. A walk of a mile or two along a suburban or village street ought to show all the variety of tree growth, shrubbery and hardy herbaceous plants that can be found in the surrounding country or in the best parks exclusive of their greenhouse and aquatic plants. The upper outline of the planting should drop here and there, showing an expanse of clouds or sky, a beautiful house or attractive grounds. This variation can be made by using for the taller trees, elms, maples, oaks, beeches, lindens, tulip trees, honey locusts and many others. These should be placed in irregular groups, such an arrangement being far more pleasing than straight rows and the only arrangement which would admit of the selection of different species. Trees placed in a row should be of one kind, at least for one block, and as nearly

alike as possible. For a smaller growth use Juneberry, sassafras, red bud, the larger dogwoods, the various thorns, blue beech, ironwood, etc. These are all beautiful trees and will often shade a sidewalk while allowing the sunshine to reach the house. Then I would urge the use of a still smaller growth, such as witch hazel, sumachs, including rhus aromatica, the smaller sized dogwoods with red bark, barberries, Japan quince, buckthorns, syringas, sweet briar, etc. These will hide, to some extent, the naked trunks of trees and give a soft, varied outline to the street view. They separate the sidewalk from the driveway, giving an agreeable seclusion. They help to make a beautiful and interesting walk from the railway station or office to our homes at all seasons of the year—in spring and summer, with the variety and freshness of their foliage and flowers, which are placed where they are most easily seen; in autumn, with their foliage and and fruits, and in winter, with the soft colors fine spray of their branches. Finally, I would recommend the use of hardy perennial herbaceous plants—snowdrops, crocuses, hepaticas, trilliums, lupins, golden rods, wild sunflowers, asters, etc. It will be said, of course, that these flowers as well as those of the shrubs will be picked and the plants destroyed. The same objection was urged in regard to flowers in public parks, before these parks came into existence and proved that such fears were for the most part groundless. To learn to enjoy a flower without picking it and to see or hear a bird without wishing to throw a stone at it, should be a part of every child's education—yes and of every grown person's too. At more or less rare intervals we go miles to enjoy the beauties of a park, and this is quite right and justifiable. But how much enjoyment would be added to our lives if we could have these beauties distributed along the streets that lead to our dwelling places, where we would see them every day; and not to our lives only, but to those of strangers and visitors, who after seeing how attractive a public thoroughfare might be made, would perhaps imitate the example in their own neighborhood.

The general public has not yet learned to appreciate what a very useful person a landscape gardener is. They fail to recognize the fact that by following his suggestions they save money, enhance the value of their property, and, what is more important, add to the pleasure of living. The landscape gardener's name does not appear on the city pay rolls, but the engineers has a hold on the public, and so I appeal to him to give more thought to the artistic side of his profession. If there are natural variations of surface, running brooks,







to mankind, both commercially and socially.

In a country of so vast an area and with climatic conditions so varied, the establishment of such parks is a matter that should receive close attention as a question of public policy. Our government agricultural experiment stations play an important part in the economy of the country, but cannot supply the place of the botanical garden, carried out to its possibilities. The Royal Gardens at Kew have benefited the world to an extent unknown to the people at large, and their influence have been world wide.

Mr. John F. Cowell is the director of the Botanic Garden of Buffalo. In area the tract comprises about 155 acres.

---

#### Nature Versus Art.

Although stiffness and formality have of late years in a great measure disappeared from the flower garden, thanks chiefly to the persistent preaching of the apostles of Nature *v.* Art, one is often discouraged by chancing upon gardens, some of them large, some but a yard or two in extent, upon which evident and loving labor has been expended, with a result that makes the heart of the lover of Nature sick within him. Who does not know the flint or clinker erections, fashioned with infinite, but fiendish ingenuity, of some railway or coast-guard stations? Once, indeed, at one of the former I saw a spar and clinker locomotive that must have taken months to complete. These receptacles generally contain a few Wall-flowers, Antirrhinums, or Marigolds, flowers that with their natural setting of brown or red earth or grass verge have a simple charm that they are effectually bereft of by their blatant caskets. To such gardeners, however, a sense of delicacy makes it difficult to speak one's thoughts. I always find when it comes to the point that I am too much of a coward to condemn to the proprietor what to him is evidently such a source of pride, and end by leaving him to worship the goddess Flora after the manner of his mistaken sect, which, alas! is not to be met with only in the small plot of the working man, for in many a large garden the time-honoured motto *ars est celare artem* is glaringly ignored.

I have in my mind a public garden which might be very beautiful; even with all the sins of commission that have been perpetrated within its borders it is still beautiful. The first impression forced upon the stranger on entering is that the gardener's chief aim is to impress upon the public's notice the grandmotherly care that he takes of his charges. Nothing is allowed to grow 6 inches high without a stick and a tie. Torture at the stake is apparent on every side. During the last summer bushy

Fuchsias were planted in quantity and their shoots tied to yellow Bamboo canes, some of the specimens being fixed up with as many as twenty; in fact, the poor plants seemed always of secondary importance to conspicuous sticks that spread them out so stiffly. A bed of giant Sunflowers had inch-square stakes over 6 feet in length driven into the ground beside each plant before the latter were 2 feet above the soil; consequently, until the flowers were produced and growth completed, the stakes were the chief feature of the plot, and some of the plants not growing over 4 feet high never attained to more than two-thirds of the height of their respective supports. The most striking error, however, in the matter of staking in this garden occurred in the case of a flowering Aloe (*Agave americana*). I noticed the flower-spike just as it protruded from the huge serrated leaves; so evidently had the ever-watchful staker, for a deep excavation was being commenced at a distance of about 3 feet, and on the next occasion of my passing a gigantic mast about 20 feet in height, like an emerald-green scaffolding pole, towered over the abashed succulent. As the spike, far slenderer than its bulky wooden companion, grew it was securely fastened at intervals to the pole, which was eventually shortened to about 12 feet, the height of the Aloe's flower-spike. Now if support had been necessary in this case, it could have easily been given in a way that would have been almost unnoticeable, but as bad gales do not occur during the English summer, and as the Aloe's candelabra weather in their thousands many a bitter gale in their native habitats without being levelled to the ground, the inference is that the disfigurement was entirely gratuitous. It spoilt the quaint effect of the Aloe's inflorescence and was merely a monument of misjudgment.

On the largest piece of turf in the garden of which I write, the name of the town is cut out in letter beds, which are planted with *Pyrethrum aureum*. It is difficult to believe that any educated person could find subject for commendation in the atrocities I have described, yet so depraved, or rather I should say so unenlightened, are the tastes of many, that a section of the public is prouder of all this misdirected zeal than of the many beautiful objects and effects that the garden still affords. S. W. F. in *The Garden*.

---

Dr. Thomas Holmes of Brooklyn, N. Y., claims to have perfected an embalming process which he has been working on for several years. He states that he is able to turn the human body to stone by a process of petrification. He calls it the antiseptic gas process of embalming.



### A Greenland Cemetery.

With Melville Bay as the objective point, I boarded the steamship "Miranda," July 7th, 1894. After many delays caused by fog, collision with an iceberg, and striking a hidden reef, we anchored in the little harbor of Sukkertoppen, (Sugar Loaf)



NO. 1.—LOOKING SOUTH.

Greenland, in early August; a settlement of four hundred Esquimaux under the Danish flag, a race without a history or a nationality; a people of Asiatic cast, whose progenitors were probably from a warmer clime.

How came this peculiar people to inhabit a frozen region can only be guessed at. The belief is that in ages past their ancestors were forced north by tribal wars, probably before the date of the English Channel, and hence through some emergency reached the north coast of Greenland, when that portion of the earth's surface was more temperate than now.

As the cycles of time rolled along and the ice fiend claimed possession of all that is now known as the great snow cap, this remnant of a once more important tribe worked its way down the coast to

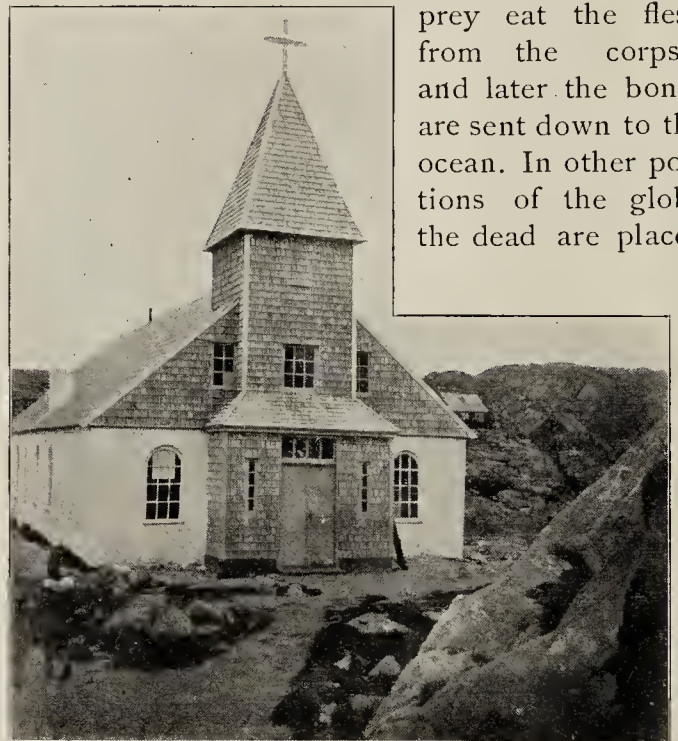


NO. 2.—OPENING GRAVES.

Davis' Straits where they now struggle in poverty for existence. While waiting for relief, a matter of two weeks, we took in the settlement and its surroundings. My first thought was, in case of death where might we be buried; but in any event I desired to see the place where the Sukkertoppers buried their dead. Their method of burial is not as they would have it if living in a more favored clime, but is forced by the conditions of climate and surroundings.

Disposition of the dead has been from remote times mostly a grave subject. The ancients had a way of embalming and depositing in tombs, hence the mummies; also cremation in a rude form was practiced. To-day in India some deposit their dead in the water, and the high caste leave their dead on the roof of a mausoleum or chapel, where the cor-

morants or birds of prey eat the flesh from the corpse, and later the bones are sent down to the ocean. In other portions of the globe the dead are placed



NO. 3.—LUTHERAN CHURCH.

in trees or on poles.

It remains for the poor Esquimaux of Greenland to show to the civilized world that the dead may be buried without digging a hole in the ground. In Greenland, cremation, or earth covering, or embalming, is utterly impossible, and owing to the climate quite unnecessary.

The views of the cemetery at Sukkertoppen, which accompany this article, were photographed by the writer in August, 1894. No. 1 represents the cemetery looking south towards Davis' Straits. It is a plot of about five acres in a canon, the rock projections exhibiting deep glacial marks. No. 2 shows the party opening graves to collect specimens for scientific purposes. No. 3 is the Lutheran Church. All of the Esquimaux, south of Melville



Bay are Lutherans, having been Christianized many decades ago by the Danish missionaries. I found the Esquimaux were poor in all things except good nature, and were especially poor as to a suitable ground where to deposit their dead, there being no soil or vegetation in all that section.

Our two weeks stay gave us ample opportunity to visit the natives in their homes, which are simply squalid huts, but no chance to see a funeral. However, I visited the cemetery and found as follows: that as there are no trees there can be no wood, hence no coffins. The only wood on Greenland coast is either brought from Copenhagen, or caught from the drift. The dead are simply laid on the surface of the rocks wrapped in sealskin.—Hair seal is the main stay of the natives: skin for clothes, flesh for food, fat for light and heat. The body is then covered to the depth of perhaps ten inches with moss scraped from the sides of a friendly rock, over which are mounded stones of various sizes to keep the body from wild animals, and as a monument. In the view showing a party exhuming for specimens, the reader will observe that the graves are simply stone mounds. We found in all of the old graves only skulls, securing five in good condition in one mound, and no other bones. A fine collection was gathered, but alas, they all went down on the steamship "Miranda."

There are exceptions to the average mound. The Danes, who are in control of all the Greenland coast below Melville Bay, have a wooden enclosure surrounding their graves, the wood being brought from Denmark; and the wooden crosses are for the more favored or better portion of the Esquimaux. All else are filled with the poor, simple children of the frozen North, and their only monument a heap of stones, which in a later day is overturned by some explorer in search of human frames in the interest of science.

This brief article cannot give the reader my thoughts fully as I contemplated this God's Acre. Here are the bones of human beings, some of them, perhaps, descendants of kings from Southern climes in centuries past, and beyond the memory or history of the living. It was noticable that the mounds exhumed brought to light mostly skulls, furnishing evidence of antiquity, probably of those who died before the Lutheran missionaries spread the Gospel of Christ on the Greenland coast. Yet the method of burial remains as before, even though the present generation are blessed with religious rites. The people of Greenland on the western coast below Melville Bay are all nominally Christians, and dispose of their dead in the same manner as at Sukkertoppen. It has been frequently asked, "why do the Esquimaux remain in the frozen region?" The

answer is plain and simple. They do not know of the outside world, and withal, have neither the desire nor facilities to leave their bleak and desolate habitation. To bring such a race to a warmer climate and to civilization would insure their entire extinction. The future of this side tracked race can only be imagined. My thought is that ere many decades, they will become obliterated.

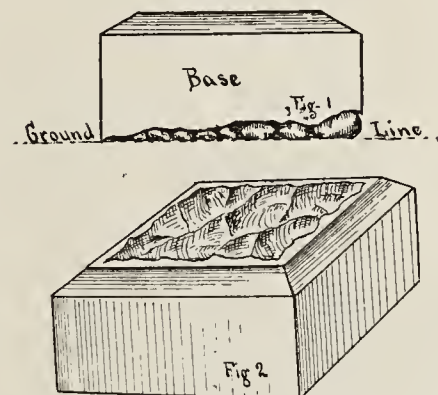
*James D. Dewell.*

#### The Bedding of Monumental Work.

A pernicious practice exists in the finishing of monumental work that should be remedied, and we are glad to note that one of the leading cemetery organizations, recently refused permission to a contractor to proceed in the erection of some work that contained the glaring defects to be described.

Figure 1 illustrates the bottom bed of a base that shows carelessness and neglect in finishing. The bottom bed is left just as the block came from the quarry and has never been taken out of wind. To level this base requires the use of various sized stones "chucked" under the edges, and outside of the question of durability, it presents an unsightly and flimsy appearance that destroys the whole beauty of the monument, and breaks the even connection which should exist between the base and

the grade line. A few hours work when the stone was being prepared would obviate all this trouble, and at the same time impart to the structure a finished appearance that it never could attain with the base left as



shown in the upper figure of the accompanying cut.

Figure 2 shows the bed of a granite base that we are all familiar with. In taking this bed out of wind, the cutter merely runs one margin draft along the edge, and then with drill, plug and feathers, he proceeds to concave the center. We have seen bases when the lead in the joint would slip clear through, so close was the level margin on the bed. These bases, especially large ones, are called upon to sustain immense crushing weights, and when the entire pressure is left to be carried by these extremely narrowed margins, the result is a crack or fissure. Then again these holes in the bed make receptacles for water and moisture, and a close observer will note that the constant freezing and thawing of such quantities of moisture near the edges will produce a disintegration and honey combing



of the blocks. On large blocks the beds should be dressed back perfectly level for a considerable distance from the joint, and then there is no excuse for the immense holes to be concaved out, except the plea of expense, and this should not be allowed to enter into the consideration.

Attention to this feature of construction by the monument trade, will result in a decided improvement in the permanency and general appearance of monumental work. Reliable, conscientious dealers always welcome an improvement in anything that pertains to the betterment of their work, and if they would call the attention of their patrons to these points and then insist on their adoption, they would do the whole fraternity a decided favor.

*C. T. Stickle.*

---

#### Knowing How.

One of the most celebrated painters was asked by a pupil—How to succeed in his profession: “First know what to do, and do it” was the answer. This can be applied to the work of the cemetery superintendent, more especially where the work to be done is intended to be of a permanent character.

The mistakes too often made in preparing and planting, when constructing new cemeteries, through lack of fore-thought, is the cause of endless trouble and expense in trying to remedy the blunders. Indeed, many, from a variety of causes, cannot be remedied, adding much to the cost of maintenance and are frequently the cause of non-success, from a financial standpoint.

Several instances occur to the writer where large cemeteries have been badly prepared by incompetent persons, to the great discouragement of the promoters. The subscribed capital is exhausted and instead of the institution being a success it drags.

A great number of persons consider themselves competent by reasons of their technical training, as surveyors or engineers. This may be true as regards laying out a park when the land will not be sold; their errors can be rectified without interfering with vested rights; but in a burial ground where the land has to be sold off in small parcels, the landscape improvements should be so arranged as to require no alterations in the future. The planting of a tree may only cost a few cents, but the removal of that tree when surrounded by costly tombstones, will likely mean the expenditure of a goodly number of dollars. Then again there are so many seemingly small details in preparing a cemetery, which only practical experience can suggest their requirement. Too frequently elaborate designs are prepared, all very well to catch the eye of the inexperienced. The topography of the ground and the landscape effects have been but little studied,

with the consequence that the land has to be made to fit the plan, instead of the plan fitting the land, and an expensive lot of work in cutting and filling has to be done.

In the April issue of this journal Mr. Olmsted is quoted as saying that no special training is required to render a person a competent superintendent. The words surely do not thoroughly express this gentleman's meaning. Possibly the idea to be conveyed was that true Artists are born, not made. For if experience was ever required in any profession it is in that of a cemetery superintendent, who if he is lacking in experience, then his knowledge has to be purchased with costly errors.

Only last year after the superintendents, convention several of the members were invited to look over a large new cemetery which was in process of construction. The promoters were dissatisfied with the way the work was being done. On visiting the place, the costly mistakes were apparent to the deputation, who strongly advised suspension of operations and the engagement of a person experienced in the requirements of a modern cemetery. This is only one of the many instances which can be mentioned. Before entering upon any new work, be it only preparing a new burial section, careful study should be given as to its appearance when completed. Picture it in the mind's eye. Look at it from several standpoints, change frequently till all is satisfactory. Then photograph it on the brain and go to work, and as the work proceeds it will be astonishing how familiar that work is. Hap-hazard work is rarely satisfactory.

It must be borne in mind that according to modern ideas a cemetery must be park like, yet the requirements are more than those of a park. The landscape effects must embrace all the beauties of the latter combined with the utility of a burial ground.

Another phase of “knowing how” can be applied to the improvement of old burial grounds, the great majority of which are greatly in need of improvement. A visit to most of the prominent cemeteries in the larger cities will amply demonstrate this fact. What was suited to the requirements of the communities in the days when our large cities were little better than villages, are scarcely up to date principles. True these cemeteries may be kept clean and trim. Yet the expenditure of a little money would vastly help the general appearance. Not very long ago the superintendent of one of these ancient burial grounds determined, although contrary to the wishes of the directors, to fix up at least one section and show what could be done. The section was an incongruous mass of stone, shrubs and trees. The numerous stone markers at

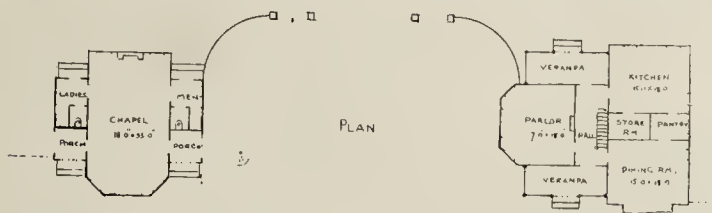


corners of each burial lot were of various heights, sizes and shapes. The first step was to lower all of these flush with the surface. Then bring all grave markers to a uniform height. Toppling monuments were straightened. Shrubs thinned out and a number of the larger trees removed, the latter being the most costly proceeding. The change was marvelous and the president of the association on seeing the improvement exclaimed: Had I known it could have been done so easily, it should have been done years ago. But unfortunately he did not *know how*.

*Bellett Lawson.*

**Entrance to Forest Hill Cemetery, Fredonia, N. Y.**

The accompanying illustrations represent elevation and plan of the proposed Gate Entrance buildings to Forest Hill Cemetery, Fredonia, N. Y. The perspective views speak for themselves, as being simple in design but withal substantial and pleasing. In construction they will be built of Potsdam



red sandstone, laid in random bond rock-faced ashlar, with cut dressings. The chapel will be finished in quartered oak and the Gate Lodge in natural hard pine. The roofs will be of tile.

The gates will be of wrought iron of special design.

The inside finish of both buildings will be thoroughly first class. The designs are the work of Mr. E. A. Curtis, architect, Fredonia, N. Y.

**PROPAGATING RARE, HARDY PERENNIALS.**— Many perennial herbaceous plants are propagated by taking up the roots and dividing them in the fall of the year. Others are easily propagated by letting them seed and sowing these seeds; but even these methods of propagation are not always rapid enough for the desired increase of any particular plant. It is not generally known that plants can be made by cutting up flower stems. For this purpose, the flower stem is allowed to grow up to a blooming point; but when that is reached the flower buds must be entirely cut away. This throws more vital energy into the flower stem, and well-developed buds form in the axils of the leaves. In a few weeks, after the flowering heads have been pinched out, the flower stalks may be separated for cuttings. Pieces with two or three buds are sufficient. In this way such plants as the hardy phlox may be very rapidly increased. The various kinds of lilies can be propagated in the same manner. This information which should be found of considerable value we take from *Meehan's Monthly*.





**Greenhouses.—How to Build. VII.**

The ridge must be exactly midway between the gutter sills on the two sides of the house or between the gutter sill on one side and the wall plate or wall plate sill on the other, as the case may be. If the house is 18 ft. 8 inches inside, from sill to sill, the level or horizontal distance from the upper angle of the sill to the side of the ridge will be 9 ft. 4 3-8 inches, the ridge being dressed to 1 3/4 inches thick and the angle of the sill being 1 1/4 inches from its inner edge. If the rise is 6 inches to the foot the vertical height of the ridge above the sill angle will be 6-12 of this distance (9 ft. 4 3-8 inches) or 4 ft. 8 3-16 inches. If the rise is 7 inches to the foot, the vertical height will be 7-12 of the horizontal distance. It should be noted that the height of the ridge is the height to the *lower edge* of the glass grooves in its sides.

The end of the ridge is now to be brought firmly against the side of the shed, at the proper height and fastened by an iron or wooden bracket underneath. It is then brought to the proper position and braced and stayed throughout its length, temporarily, to keep it rigid until the bars are in place. Great care must be used to have it exactly the proper height and equidistant from the gutters. Any variations will cause the sash bars not to fit, and greatly add to the subsequent work. The gas pipe supports are then to be put in place, 6 of them in a 52 foot house which will bring them a little over 7 feet apart.

Fig. 14 shows the gable end bars used at the north and south ends, 1 is the roof glass, 2 the vertical glass at the south end, not used, of course, at the north end, 6 the drip groove, which will face north on the bars at the south end and south on the north bars. (For Fig. 14 see last issue.)

The end bars and intermediate bars will all be cut and mitered at the mill to make an exact fit. Figs. 7, 8 and 9 show the manner in which the lower ends of the bars (2) are joined to the sill or wall plate. The body of the bar butts square against the angle of the sill or plate and the tongue extends over and rests on the other bevel. A small nail is driven through the projecting tongue into the sill and a nail is "toed" in on each side through the body of the bar. The ridge joint is a simple miter joint. As soon as received from the mill and inspected, and before priming, the bars should be stood on their lower ends in boiled oil about 6 inches deep to become thoroughly soaked, after which they are taken out dried and primed.

Before the bars are set, the glass should be on the ground so that the bars can be spaced to fit, as different lots of the same so-called size will vary a trifle. The *glass space*, between adjacent sides of

the tongues of the bars should be 1-16 inch more than the width of the glass and the bars should not be set until they have received the second coat of paint. A thick coat of paint applied after the bars are set will make the glass fit too tight.

The ventilating sash will have been previously provided for. If a patent sash lifting apparatus can be afforded, and a good one is a great convenience, the sash will be narrow and form a continuous line along the ridge. If a double row is used, one on each side of the ridge, so much the better, but it requires two machines. Ordinarily in a 52 foot house about 3 ventilators would be used on each side of the ridge arranged alternately. These would extend 3 or 4 feet down the roof and would be just wide enough to cover two rows of glass and the tongues of their outside sash bars, requiring them to be about 2 inches wider than the actual width of the glass in the two rows.

Ventilating sash are quite similar to ordinary window sash, except that there are no cross muntins and the lower rail is thinner than the upper, its surface being lapped by the glass so that the water flows down the sash and over the rail freely.

The sash bar which would otherwise be under the centre of the ventilator is made shorter than the others and is attached to a header which is fitted in between the two bars on each side of it.

Fig. 12 is a section across the header showing method of attaching the short bar, 12 is the header, 6 the drip groove carrying the drip across to the long bars on each side, 3 is the lower end of the

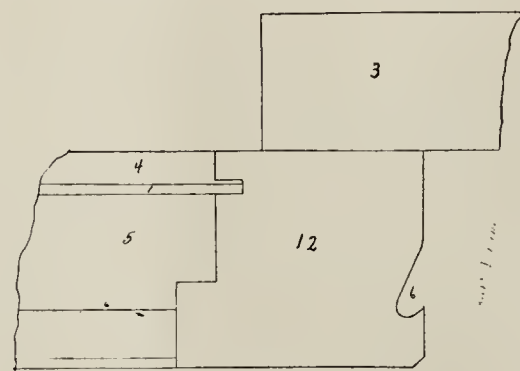


FIG. 12.

ventilator resting on the header, 5 is the short sash bar carried on the shoulder projecting from the header, 4 the tongue of the bar and 6 the

line of its drip groove, 1 is the glass resting on the shoulder of the bar and projecting into groove in the header.

The sash lifter commonly used is a piece of strap iron about 3-16 by 3-4 or 1 inch and long enough to be easily reached when the sash is raised to its full height. At the upper end a hole is drilled and a staple passed through, the ends of which are riveted firmly to a small iron plate, allowing the strap iron to swing loosely. The plate is bolted (screws invariably come loose) to the lower rail of the sash at the middle. Holes are drilled at intervals through the strap iron and a substantial iron peg is attached



to the side of the header just above the drip groove. To raise the sash the iron handle is grasped and the sash raised as required; the handle is then carried towards the peg until the peg passes through one of the holes, holding it securely at the proper elevation.

The ridge being in place, next comes the setting of the bars. The north end bars are put in first, nailed to the ridge and sill and to the shed, as they come against the sheathing of the shed all the way. The south end bars are set so that the inner or north edge of the groove for the vertical glass (Fig. 14-2) shall be exactly above the inside (north) edge of the ship lap when placed on the south wall. In setting the bars two men will be needed, one at the ridge and the other standing on the ground to nail the lower ends. If the utmost care is not used here, a great deal of trouble will be caused in setting the glass.

Two gauges, strips of wood cut perfectly square at the ends and exactly one sixteenth inch longer than the glass is wide, should be prepared. Beginning at the south end the first intermediate bar is put in place, a gauge put on at the ridge and one at the sill, resting on the shoulder of each bar with their ends against the tongues of the bars. The intermediate bar is then crowded closely against the gauges and nailed in place, top and bottom. The corresponding bar on the opposite side of the roof is then set and so on. If the work is advanced further on one side the roof than the other, the ridge is quite apt to be forced out of place. When the space for a ventilator is reached a long bar is used temporarily instead of a short one, tacked lightly in place and then removed as soon as the bar beyond is set. After all the long bars are set the headers are put in and the short bars set.

In all work about the roof, have the pot of thick paint handy and in case it is necessary to re-cut any joints, smear the cut surfaces with the paint before fitting them together. In fact it is well worth while to give all the ends of the bars a fresh coat of thick paint just before they are set. This makes an almost perfectly water tight joint.

The ventilator sash are glazed first, then put in place before the roof is glazed.

*Willis N. Rudd.*

*(To be Continued.)*

#### **A Flower Bed at Girard College, Philadelphia.**

Girard College, Philadelphia, is famous for its beautiful flower beds in summer. Of the College itself it may be said, that it was founded by Stephen Girard, who came as a poor boy from

Bordeaux, France, nearly 100 years ago. Becoming wealthy, he left the whole of his money to found a college for the education of orphan boys, and to day some 1,500 boys find a home there. They are eligible to admittance at an early age, 6 years, and are permitted to remain until they are 18. Some of the best men in the state to day are graduates of this college. For fear his college might be hampered by denominational influences, his will provides that no clergyman or ecclesiastic shall ever enter the building, but the boys are to be taught sobriety and industry, and to be left to their mature years in their choice of denominational truths.

The illustration given is of a fine bed of abutilon Thompsoni, a sort much used for the purpose because of its mottled green and white foliage. Mr. George Huster, the gardener in charge, gets his plants rooted in the fall, and they are encouraged to grow all through the winter. When spring comes they are in four inch pots, and by an arrangement of the taller ones in the centre, they need but little



FLOWER BED AT GIRARD COLLEGE, PHILADELPHIA.

attention in the way of pruning all summer. The bed, however, is not of abutilon altogether. Following the plants of this, which, as stated are in the centre, are two rows of the beautiful *Acalypha musaica*, a dark bronze foliaged plant, of great use in bedding. This is followed by *alternanthera* for the outside.

Two large trees which stand immediately back of the bed are the tulip tree, *Liriodendron tulipefera*, a tree of clean growth and beautiful appearance always. Back of these trees is seen the conservatory a structure recently erected.

*Joseph Mechan.*

The U. S. government has relinquished its ownership of the military reservation of Mackinac Island. It is now in order for the state of Michigan to enact the necessary legislation to make the greater portion of the historic and picturesque spot a public park. The place is full of interest, is a charming summer resort and replete with natural beauty and delightful surroundings, and a liberal policy on the part of the Michigan legislature will inure to the credit of the state,



**Soldiers' Memorial, Oakwood  
Cemetery, Syracuse,  
N. Y.**

The Woman's Relief Corps adopted a vase, illustrated here-with, for their memorial to The Unknown Dead, on the Soldier's lot in Oakwood Cemetery, Syracuse, New York. This form of memorial is rare, and its adaptability for such a purpose has been quite generally overlooked.

It is true that in certain seasons of the year it is shorn of its natural embellishments, but the design of this vase may be such that it will form an attractive feature at any time, and art has exercised itself through all the ages on the vase, so that from the standpoint of design there is great latitude.

The plants flourishing in the vase at the time the photograph was taken are as follows: Cannas for the Centre,—Palms may be used; Geraniums, Coleus, Begonias, Dracenas, Fuchsias, Humulus, Nasturtium, Petunias, Thunbergia, Torenia, Verbena, Vincas, Anthemis, Clematis, Gaillardia, Lobelia, Pyrethrum, Euphorbia, Ivy, Nierembergia, Ficus and Lantanas. The vase is a very large one requiring quite a stock of plants, but the effect is rich and with the elegance the class of plants impart. The foregoing list was kindly furnished by Mr. Burritt Chaffee, Supt.

**"Tam-na-Urich."**

The Hill of the Fairies, at Inverness, N. B., the capital of the Scottish Highlands, is probably one of the most unique cemeteries in the world. For untold ages this isolated hill on the banks of the Ness had excited the wonderment of the Highlanders who attributed to it a supernatural origin, so singular is this steep convexity, like a bowl turned down on a table. Sometime about 1865, the city purchased this hill for a Cemetery, and without any parade of plans, or the advertisement of those who suggested so daring an innovation, a burial mound was made of it which will endure for all time, and defy the sordid projects of generations of jerry-builders,



MEMORIAL TO THE UNKNOWN DEAD. (From Picturesque Oakwood.)

The hill was lightly wooded, to smooth much of its surface was impossible, but a small portion of the top was levelled, and those lots no doubt held at a fancy figure. Strangely enough the very first interment upon the plateau was a suicide, and it was gruesome to hear the comments of the Highland Grannies, and their doubt whether the community could be justified for any money, in permitting such a burial in so prominent a place. "Would it not have been more seemly to have sought the seclusion of one of thae glens?"

The road was carried from this platform downwards at as nearly one grade as possible until the level was reached, and it wound round and round about like the thread of a screw, opening up all the glorious scenery of mountain, river, lake and Firth.

I imagine Tam-na-Urich will never be seriously marred in its aspect, never suffer the obliteration of its features, never have the repose of its dead disturbed, but in its awesomeness and grandeur will endure and increase in solemnity down through all



the ages, and that many and many will be the themes threaded into the history of the famous Fairy Hill of Inverness.

Absolutely nothing was done beyond what I have said, except permission was given to plant trees, shrubs and plants. On such a site they can never be incongruous. All the plans on earth could not improve it.

*James Mac Pherson.*

**Ninth Annual Convention of the Association of American Cemetery Superintendents, Richmond, Va.**

PRESIDENT'S NOTICE.

This meeting, to be held Sept. 18, 19 and 20, 1895, will be the ninth annual convention of the Association of American Cemetery Superintendents, and it is hoped will be as well attended and as instructive as previous meetings have been. About twenty superintendents met at Cincinnati in the fall of 1887 and perfected an organization which has grown until, at the present time, it numbers nearly seven times the original membership. The object of the Association named in the Constitution, is the "advancement of the interests and the elevation of the character of cemeteries in America." This object is always kept in mind and furnishes the keynote to each meeting. The papers and discussions have related to the management of cemeteries, the best methods of making improvements, and the artistic character that should be given to burial places. That these papers and discussions have been appreciated is attested not only by the increase in membership, but by the continued attendance through a series of years of those who became connected with the organization at its conception. Cemetery superintendents and officers are eligible to membership, and since the object, as stated above, is general and not personal, all cemetery associations should make an effort to send a representative to the annual meetings.

Many of the problems to be solved in the creation of a modern cemetery; such as, the location and construction of roads, the arrangement of planting, the making of lakes and the treatment of their borders, the treatment of road margins, the planting of the boundaries, etc., are the same that are confronted in the improvement of public parks. We therefore extend a special invitation to all interested in parks as well as those interested in cemeteries to attend our meeting. This relationship between the character of cemeteries and that of parks has already been acknowledged by the paper in which this notice will appear. While we are making an effort to improve the character of cemeteries, we recognize the fact that our cemeteries can reach the greatest perfection only with the growth of a better

taste among people generally. An improvement in cemeteries insures an improvement in home grounds and a greater appreciation of out-door beauty, thus aiding the advancement of civilization and cultivated taste. This growth of a cultivated taste will react in a beneficial way on the cemetery.

Let all who can, attend the meeting at Richmond, listen to the papers read there, participate in the discussions and then go home and help to spread the gospel of natural beauty.

*O. C. Simonds, President.*

SECRETARY'S NOTICE.

TOLEDO, O., JULY 10, 1895.

To Members of the A. A. C. S.

I am glad to announce that preparations are well under way for our September meeting at Richmond, Va., and that a sufficient number of papers have been promised which with discussions will occupy all the time we can devote to them. The following partial list will give an idea of what is in store for us. Greenhouses in Cemeteries by J. G. Barker; Drainage by A. W. Blain; Cemeteries on Western Plains by J. Y. Craig; Obstacles to overcome in Starting new Cemeteries on the Modern Plan, J. Gunn; Irrigation in Cemeteries, F. Van Holdt; Cemetery Boundaries, T. McCarthy; Our Native Trees and Shrubs, J. H. Shepard; Suggestions for the benefit of our Association, Chas. Nichols; Hints on Gardening, Frank Eurich; Derivative benefit of our Association, Geo. H. Scott; Our experience with road drainage, J. C. Cline; and a few more not ready to announce. Members desiring the discussion of any question or topic will please forward same at once so that they can be placed upon the program, which will be published in full in August number of PARK AND CEMETERY.

Mr. John R. Hooper, chairman of the Executive Committee, writes that Hotel "Murphy" has been selected as the place of meeting and abode as well and has secured special rates. American plan \$2.00 to \$3.00 per day, European plan 75 cents to \$1.50 per day, the latter with bath and toilet. The Murphy is located corner Broad and 8th streets, easily reached by cars, and within two blocks of the City Hall and State Capitol.

These annual meetings are as profitable to cemeteries as they are pleasant to the superintendents and I hope you will all make special efforts to be on hand and make this meeting equal, if not superior to those of former years. Look for full program and further information in August number of PARK AND CEMETERY, but in the mean time try to induce some new man to join and meet with us and above all make your own preparations to come.

*Frank Eurich, Sec'y and Treas.*



## BRING PHOTOGRAPHS.

A photograph is often more instructive than a long written article. It seems to me that nothing would do more to make the meeting of the Association of Cemetery Superintendents at Richmond interesting than to have on exhibition good photographs of the various cemeteries. These should be selected to illustrate special features, such as, pleasing vistas, water margins, driveways, backgrounds for monuments, areas containing too much stone-work, views showing the effect of hedges, coping, fences, hitching posts, projecting lot stakes, cemetery boundaries, natural grades, a tree or shrub when in bloom, satisfactory use of flowers, effects of planting at different seasons (as views in winter, early spring, summer, etc.), cemetery entrances, the operation of planting trees and shrubs, the construction of roads etc., etc. Bring anything in this line that would be instructive either from its good qualities or its defects. It is not necessary that it should be taken in the cemetery you represent or, indeed, in any cemetery at all, if it has a lesson to teach. Well selected photographs will help all who attend the meeting and they will help most the ones who make the selections.

*O. C. Simonds.*

## Notes.

The desirability of employing an architect or an artist to make the design of a monument is not generally appreciated and the natural consequence is that nine out of ten monuments in cemeteries are ugly in the extreme and exhibit a collection of lines and surfaces without any meaning. The assumption on the part of a man, whose only knowledge is that required in cutting stone, to be able to make designs for monuments is on a par with that of the carpenter who assumes the duties of an architect without previous study and training. Both men produce pitiable results, yet a majority of our designs for monuments come from such sources.

*O. C. Simonds.*

The removal of lot enclosures in many cases, and a growing tendency to dispense with anything except the most simple and inconspicuous form of boundary post for lots, is working a great change for the better in cemeteries; but as the number of burials in each lot increase, the monuments and headstones increasing in proportion, must inevitably become unduly prominent, and if they do not eventually conceal or destroy, will certainly most seriously impair the lifetime labors of the most successful landscape gardener, unless measures are taken in good season toward obviating, as far as possible, a result so undesirable.

*J. W. Lovering.*

## Pointers for Cemetery Officials.

Encourage the discriminate planting of hardy flowering shrubs.

Discourage Sunday funerals.

Many styles of monuments look best when partially covered with ivy or some hardy vine.

Workmen whose duty it is to lower coffins into graves should be respectably clad. In many cemeteries uniforms are provided.

Study natural effects in shrubbery and adapt them to your grounds.

Every cemetery should have a Perpetual Care fund.

Parks and cemeteries should be divorced from politics.

Foundations for monuments should be as deep as adjacent graves.

Families should be advised to purchase adjoining lots and have one central monument.

In a cemetery properly inclosed, fences around lots should be prohibited.

Lot coping increases the cost of caring for a lot and detracts from its appearance.

Grass paths between lots are less expensive to maintain than dirt or gravel walks and enhance the beauty of a section.

High grave mounds are unsightly. Some cemeteries prohibit them more than three inches in height.

Employ a competent landscape architect to lay out additions, or new grounds, and conduct them on the lawn plan.

Permit only one monument to a lot and recommend low headstones.

Fill up and sod over some of the paths that divide lots. A path round every lot is unsightly and unnecessary.

Adopt a uniform grade for every section and maintain it.

Head markers set in sockets should be prohibited.

Berry bearing shrubs, properly distributed and arranged, afford pretty winter effects.

July and August are hard months on lawns. Water and water and water!!

Poorly ventilated receiving vaults are a reflection on a cemetery. If defect is irremediable, be lavish with disinfectants during the summer.

Construct your roads on best principles which will reduce cost of maintenance. They are permanent features, subject to the hardest usage, and hence should be durable.

Gasoline sprinkling is an effective remedy for weeds in the gutters.



▷ PARK NOTES. ◁

Landscape gardening, the art of embellishing grounds, demands a high appreciation of natural scenery and an ability to represent it in grounds.—*L. H. Bailey.*

\* \* \*

Mr. John P. Hier has announced in the *Syracuse, N. Y., Herald*, his intention of endowing the city with a little park at the West Genesee street triangle, the option on the necessary property having been secured by him. Such public gifts are among the most enduring of monuments.

\* \* \*

The commission created by the last legislature of Minnesota to purchase the site of old Fort Ridgely for the purpose of a public park and to erect a monument thereon, have concluded negotiations for the necessary land and have practically decided upon the character of the monument.

\* \* \*

The Park Commissioners of San Francisco having no funds to expend on a scheme of lighting by electricity the main road of Golden Gate Park to the ocean beach, an organization of citizens has been formed for the purpose, which under agreement with the board will furnish and maintain a lighting system.

\* \* \*

An article in the By laws of a Western Cemetery decrees that there shall be annually set aside ten per cent of all sales of lots as a perpetual care fund. This should be amended without delay for the accruing amount will be altogether inadequate for the purpose intended. It should be at least 20 per cent.

\* \* \*

At the recent meeting of the Park Commissioners of New York City, a communication was received from Mr. Cornelius Vanderbilt to the effect that \$250,000 had been received by subscription for the Botanical Garden in Bronx Park, and requesting the Board to set apart 250 acres of land for the purpose.

\* \* \*

The incorporated Soldiers and Sailors Monument Association of Livingston, N. Y., has purchased a site for a monument in the town which will be improved and set out in trees and shrubs that the proposed name "Memorial Park" may not be inappropriate. Herein is a suggestion for soldiers memorials—parks.

\* \* \*

The estimated cost of the improvements about the Grant monument, which the Grant Monument Association desires New York City to carry out is put at some \$350,000. This is to condemn property between Riverside drive and the boulevard directly east of the monument, and to extend and widen certain thoroughfares so as to provide a new approach with an uninterrupted view of the monument.

\* \* \*

Mr. William C. Tallmadge has donated to the village of Mechanicville, N. Y., ten acres of land, valued at \$5000 an acre, for a park. Some months ago he volunteered to give the land on condition that the village buy up several lots that had been sold. This was refused and Mr. Tallmadge a few days ago gave the trustees a deed and thus solved the question like a true benefactor.

\* \* \*

Peabody, Mass., appears to have finally settled the question, over which so much time has been spent, viz: what to do with her legacies for park purposes. At an adjourned meeting the question was favorably passed upon, the vote standing 170 to 23. This will give the town a park of over 23 acres, and counting the use of the land recently purchased by the Essex Agricultural Society 10 acres more.

Mr. Thomas Meehan, of Philadelphia, has been the means of adding twenty-seven small parks to that city within the past ten years. These comprise in area some 775 acres, and concerning such small city parks, he urges that their use as play grounds should never be lost sight of, and the needs of the people being thus foreseen and provided for, their maintenance will be more readily adjusted.

\* \* \*

The city of Galveston, Texas, is singularly devoid of parks, due to the sandy nature of the soil. Situated on an island one and a half to two miles wide by thirty miles long, whereon every tree has had to be brought over and planted, it is hardly to be expected that parks would form an important feature. The few parks that exist are simply improved blocks, and private gardens exist only for what can be made out of them by their gardener owners.

\* \* \*

The total area of the West Parks system of Chicago, including boulevards, is 957.25 acres, of which 360.60 acres are comprised in the boulevards. Of the park lands proper 407.44 acres are improved, and there are 33.20 miles of improved drives. The South Park system embraces, including boulevards, 1306.75 acres, of which the parks take 994.9 acres. Of the park area 390.2 acres are improved and there are 35.55 miles of improved drives. Lincoln Park contains over 300 acres, to which additions are being made and extensive improvements in progress. The parks, boulevards and cemeteries of Chicago aggregate over 4000 acres.

\* \* \*

The new board of park commissioners at Hartford, Conn., have decided upon a park for poor people, says the *Meriden, Conn., Journal*. About fifty acres in the northeast part of that city, bordered by the Connecticut river, has been secured. It is near the most thickly settled part of the city. If the new park board put the matter in the language printed, it evidently is not composed of men touched by the pronounced spirit of the age. All the public parks of every city are more necessary and primarily more particularly intended for those not blessed with means than the wealthy classes.

\* \* \*

An act has been passed by the legislature of Indiana to establish a Department of Public Parks in cities of over 100,000 inhabitants according to the last preceding United States census and creating a board of Park Commissioners. The act provides a board of five members to be appointed by the Mayor, who shall serve without compensation, but whose expenses and clerk hire shall be supplied. It further prescribes the duties of said board, its powers, features under its control and financial conditions. It also defines certain relations between the city authorities and the board, and the methods to be pursued in acquiring property and assessing for payments for same.

\* \* \*

In connection with a description of Broadway Park, the second of the system of small parks being carried out by the Park Commissioners of Cambridge, Mass., the *Tribune* of that city says of such parks: "One of the greatest blessings of small park areas in the midst of busy cities is to those who have occasion to pass through them to some point beyond. To many a tired workman returning from his day's labor the passage through a space of refreshing green, where severe utility gives place to other ideas, affords him a rest and prepares him the better to meet his family, and while but few of the many who receive this benefit ever give any expression of it beyond a more cheerful countenance and a lighter step, these benefits are none the less real because so seldom spoken of. It does the workman no wrong to entice him to linger for a moment in the midst of park surroundings." Nothing is truer, and the argument is a potent one in favor of the small city park.



## CEMETERY NOTES.

A country cemetery has the following notice over the gate: "Only the dead who live in the parish are buried here."

\* \* \*

The directors of Lindenwood Cemetery, Fort Wayne, Ind., have decided to build a crematory. This has been under discussion for some years and is now decided upon.

\* \* \*

Mr. T. Streatfeild Clarkson has donated the sum of \$10,000 which is to be invested and the proceeds applied towards the maintenance and improvement of Bayside Cemetery, Potsdam, N. Y. Mr. Clarkson is now president of the association and there is a gratifying interest displayed in the welfare of the cemetery.

\* \* \*

The general fund for the improvement and permanent care of Greenwood Cemetery, Brooklyn, according to the last report amounts to \$1,716,802.06; the trust fund for the special and permanent care of lots to \$402,257 41. Two hundred and thirty lot enclosures have been removed resulting in general satisfaction among lot owners.

\* \* \*

An act has been passed recently by the Pennsylvania legislature amending the bill of 1891 as amended in 1893, and "providing for the removal of bodies from single graves to other places of interment, where the relatives of the deceased or the holders of lots cannot be found, and the sale of the ground wherein the said bodies were interred, and also for the sale of lots where the owners thereof cannot be found."

\* \* \*

The authorities of Prospect Hill Cemetery, Omaha, Neb., became involved in legal proceedings owing to their having undertaken to enlarge their boundaries, the same being inside the city limits and governed by an ordinance. This was the first complaint under the ordinance, and resulted in the president and secretary being fined \$25 dollars each "for making an effort to extend a cemetery inside the city limits."

\* \* \*

Surgeon-General Hamilton has been advising the health commissioners of Chicago to communicate with the officials of cemeteries concerning the sale of floral frames to florists by cemetery employes. The practice has been in some of the cemeteries for the attaches to remove the flowers from the floral pieces. The moss was left in the frames, and it is thought contagious diseases were transmitted when the frames were refilled by the florists.

\* \* \*

The officials of Edgewood Cemetery, Nashua, N. H., have adopted the suggestions frequently made in PARK AND CEMETERY of including in cemetery reports such selections from current periodicals and other sources as may tend to educate their lot owners and others in cemetery matters. In their last report considerable matter of the kind is incorporated with it, which will undoubtedly serve a wise purpose and cultivate renewed interest and taste in the direction desired.

\* \* \*

A pertinent remark and one affording much food for reflection occurs in the superintendent's communication contained in the report of the Allegheny Cemetery. He says: At a low estimate, two millions of dollars have been expended by lot owners, for monuments and other forms of memorials. If this sum had been equally divided, each grave in the cemetery could have been provided with headmarks or other memorials costing fifty four dollars. At present, but twenty-five per cent of the number are thus marked.

Vienna, Austria, is about to dedicate a fine monument to the memory of Mozart, but no one in all that city can tell where to put it, for the composer's grave is absolutely unknown. When he died there a hundred and four years ago his "Magic Flute" was being sung nightly at the opera, but he was suffering in dire poverty in an obscure dwelling. His widow was too ill to follow the coffin to the grave, and the friend who arranged the funeral is said to have exercised economy by having the composer's body buried in a ditch with forty others with no cross or mark of any kind.

\* \* \*

A noteworthy step was taken by the Altoona Fairview Cemetery Association, Pa., last year in its petition to the Judges of the Court of Common Pleas to amend the articles and conditions of its charter, the object being "to forever prevent said association from becoming an institution for profit to its stockholders; to remove the restrictions for the accumulation of the permanent improvement fund, and remove the restrictions as to the amount to be expended annually for the improving and beautifying said cemetery." This was a progressive step and one that should lead to a constantly increasing interest in the property. The management is alive to the practice of today as well as endeavoring to anticipate the methods of the future. In their latest pamphlet, the following has the true ring: "Simplicity, solidity and durability are essential in cemetery improvements, and if to these are added an air of subdued beauty, a harmonious blending of light, shade and color, together with neatness and perfection in keeping, little more can be sought or desired. It may be added that the president has served since 1880, the secretary since 1864 and the superintendent 24 years."

\* \* \*

A correspondent in the Palmyra, N. Y., *Courier* gives some excellent advice to the cemetery officials of that town, which would redound to their good sense if heeded, for the writer seems to know what he is talking about. In his communication he states that from a common standpoint some general system of improvement should be adopted, which only one of cultivated taste can devise. Such improvements can only be put in successful form by a skilled landscape gardener. He suggests that the village officials employ a thoroughly competent landscape gardener for a time, or at several different times, to direct and aid their young superintendent in reference to such changes as should be made, and best how to make them to add to the attractive beauty of the cemetery generally. Such an artist can tell not only what ought to be done, but how most readily and economically to accomplish any desired result, and can foresee the beauty that will be accomplished by any proposed change. A judicious expenditure in this direction would be an object lesson that would not only be beneficial to Palmyra, whose citizens would carry to their homes useful hints learned there, but would tend to cause improvement in other neighboring cemeteries of less importance. Such advice is admirable and can be appropriated to advantage by many local cemeteries.

\* \* \*

A cyclone swept over East New York, L. I., on the 13th inst. It played considerable havoc in Cypress Hills Cemetery, wrecking some handsome and costly monuments. It tore down trees for about 200 feet and then turned into Jamaica avenue at Crescent St., and went up Jamaica ave. for about half a mile. Trees were torn down and telephone and trolley wires demolished.

\* \* \*

Harrisburg, Pa., is one of the latest cities to adopt the electric funeral car. A special car has been constructed for this purpose which can be rented for funerals and run direct to the cemetery.



The equestrian statue of General John A. Logan, for which the state of Illinois appropriated \$50,000 some eight years ago, and the commission given to the sculptor Augustus St. Gaudens, is nearing completion in the sculptor's studio. It has been inspected both by Mrs. Logan and General Alger. The general pronounced it a spirited work, and historical as it represents an episode at the battle of Atlanta. It will be cast in bronze, and mounted on a marble pedestal in one of the Chicago parks. It is expected to be completed in one year.

\* \* \*

Ferns are always beautiful when the situation is favorable for their growth: the native ferns that will live and thrive in the same spot for years being the ones to plant. I have in mind a lot in a quiet portion of a city cemetery where the only attempt at floral decoration was the planting of these beautiful ferns. The graves were neatly sodded and the grass kept closely cut. Around the massive monument in the center of the lot was a solid bank of ferns at least a foot wide, and extending on all four sides of it. This was truly labor of love, for the ferns were brought from the woods by loving hands and planted near the resting place of their loved dead ones.

*Bernice Baker in Vicks Monthly.*

#### Curious Funeral Rites.

The funeral of the Greek archbishop of Corfu, which took place recently, and which afforded an opportunity of witnessing the curious funeral rites accorded by the Greek church to so exalted an ecclesiastic, is described as follows in the *New York Journal*:

The archbishop was an old man, and his death was not unexpected. For more than a month the cathedral had been prepared for his "sitting in state." The breath was hardly out of his body when the corpse was dressed in episcopal robes, and, without being embalmed, taken to the cathedral and placed in a golden arm chair, surrounded with lighted tapers, with the miter in one hand and the gospel in the other. The populace thronged to the church to view the body and to kiss the archbishop's hand. The priest desired to keep the body there for three days, but the authorities had to interfere for the benefit of the public health. The funeral was accordingly arranged for the second day. The church bells tolled continuously, the theater and shops were closed, flags were hung at half mast and the street lamps lighted and draped with crape. The whole of the inhabitants, however, treated the occasion as a fete day, and appeared in their gayest clothes. The funeral procession started from the cathedral at 8:30 a. m. Three standard bearers with church standards flying preceded it, followed by about a dozen church beadles holding lighted gilded lanterns. Next came three town bands playing a funeral march, then boys carrying artificial wreaths. Thirty-five priests followed on each side,

and an officer of the army holding a cushion with the Greek cross of the Savior and the Russian grand crosses of St. Anne. Then came the corpse tied to the arm chair—still holding the miter and gospel—carried by priests in gorgeous vestments, with the chief Greek officials taking the place of pall-bearers on each side. Directly behind followed the Roman Catholic archbishops and the representatives of foreign powers. The men of the garrison, including the mounted battery and the crew of a Greek iron-clad, brought up the rear. On arrival at the cemetery the body was taken into the church, and from there to the grave, which was like a small room. A stone chair had been built in the middle, on which the corpse was seated, and a hanging oil lamp was arranged from the arch above. When the body was lowered and some earth thrown in, a salute of twenty-one guns was fired from the fort, as well as three volleys of musketry over the grave. The bands then returned playing opera airs.

## Correspondence.

Camden, N. J., July 1, 1895.

*Editor Park and Cemetery.*

DEAR SIR:—I fail to see wherein your correspondent in reply to ENQUIRER in the issue of June, has answered my question in any particular, which was: Can you inform me whether a tax, or an assessment, can be collected from the owners of lots in cemeteries, or whether there has been a court decision in relation to the same in any of the states in the United States." I am seeking information, being a lot holder in a cemetery in Pennsylvania, which imposes a yearly assessment upon the lot owners. With others I am desirous of instituting proceedings to stop what is considered to be an unwarranted and vicious act on the part of the management. The clause in the deed of trust which was granted by the incorporators of the cemetery of which I speak, reads as follows: For the purpose of defraying all or any expense the directors may assess on each of the said smaller lots a yearly sum not exceeding 75 cents and collect from the owners thereof.

Your correspondent says: If I will look up the laws governing cemeteries in New Jersey, I will find that no cemetery can tax a lot holder unless he or she may contribute toward improvements at their own option. Such was the understanding in Pennsylvania, and as cemeteries are not subject to taxation by the state or country authorities, it was supposed they could not assess their lot owners, or at least it would not be legal to do so. Again there is no specific law governing cemeteries in the states named further than their acts of incorporation, and the rules and regulations made by their directors in pursuance thereof, so that the task assigned me to look up the law by your correspondent is rather a Herculean job. I have however obtained the following official facts: A resident of Lycoming Co., Penn., by purchase became a lot owner in the Ivy Hill Cemetery of that country. Shortly after the purchase, the directors of said cemetery, passed a resolution assessing a tax upon each lot holder. The purchaser dissented and was sued for the tax and the case was taken into court; Judge Metzger on the bench, (Sept. 1890), decided that cemetery corporations could not tax their lot holders for improvement purposes.



This decision would at a glance suggest that my question was answered, but it is not. In the case I speak of the rule to assess a tax was laid down prior to the sale of any lot or piece of ground belonging to the corporation, and every lot holder was supposed to have purchased his lot with the full knowledge of the facts, and the claim is made that the rule is binding. There is no doubt in my mind that the insertion of the clause was a device and deception practised by the incorporators, and the directors who are carrying out the provision are too thick-headed or ignorant to ascertain whether the rule is legal or not. It is one of those cases where the mills of the Gods grind slowly, but they grind exceedingly fine.

The suggestions of your correspondent with regard to a law compelling all cemeteries to set aside a certain percentage of the sales for improvements, are somewhat behindtime. The Evergreen Cemetery Co., of Camden, N. J., from its incorporation until now have set apart a certain amount from the sale of each lot, and will continue to do so until the last lot is sold. This constitutes a reserve fund, the interest form which will be sufficient to give permanent care to all the lots in the cemetery for all time to come. The act of incorporation pledges this much to the lot owners. Had your correspondent have said, "some instead of all" cemeteries, I could have agreed with him. A Cemetery Company that does not provide for the future welfare of its lot owners, is in the market only for revenue, deception and fraud, and in its final wind up will have to resort to assessment and taxation, to remain in existence.

ENQUIRER.

Oak Grove Cemetery, Tomah, Wis.

*Editor Park and Cemetery.*

DEAR SIR:—This cemetery was owned and controlled by the town of Tomah, from its inception, about the year 1873 until some six years ago. Up to that time it fared like most cemeteries which are managed by town authorities. Since that date it has been in the hands of an association which made a new plat and adopted a policy which, notwithstanding much opposition, has in six years transformed things and given renewed courage for continuing the good work. The spirit of opposition is gradually giving way and we have reason to believe we may yet have a respectable place wherein to lay our friends to rest.

I have often been encouraged by articles and correspondence I have found in the MODERN now PARK AND CEMETERY. Our association is formed of our different lot owners, which includes all classes of people. I have noticed by your paper that other places have similar troubles, and it looks to me as though there was something lacking in our state laws in their dealings with our cemeteries.

H. L. BURDICK.

### Association of American Cemetery Superintendents.

O. C. SIMONDS, "Graceland," Chicago, President.

G. W. CREESY, "Harmony Grove," Salem, Mass., Vice-President.

F. EURICH, Woodlawn, Toledo, O., Secretary and Treasurer.

The Ninth Annual Convention will be held at Richmond, Va., September 18, 19, and 20, 1895. A number of interesting papers have been promised.

### Publishers' Department.

NOTICE TO SUBSCRIBERS. If this notice is marked with a blue pencil it indicates that your subscription to PARK AND CEMETERY has expired and a renewal of same is solicited.

Park Commissioners and Cemetery trustees are requested to send us copies of their reports.

Photographs and descriptive sketches of interesting features in parks and cemeteries are solicited from our readers.

PARK AND CEMETERY wants the names of every park and cemetery officials or employee who would be likely to be interested in this paper. To the many subscribers who have sent in such lists of names, we return our thanks. There are many more that we should hear from.

Subscribers are again reminded that we want brief notes on any feature of park or cemetery work that will be of general interest. PARK AND CEMETERY is the only publication of its class and earnestly solicits the co-operation of subscribers in making it a help to all identified with such work.

Copies of Franklin, Pa., papers received from C. D. Phipps, superintendent of the Franklin cemetery, commend the manner in which Mr. Phipps conducts the grounds. The natural beauty of the cemetery has been enhanced by the judicious planting of shrubbery and flowers. Mr. Phipps is a member of the Association of American

Cemetery Superintendents and attends its conventions regularly with profit to himself and his cemetery association.

Mr. Henry Ross of Newtonville, Mass., has been superintendent of the Newtonville cemetery for thirty-four years. The *Newton Circuit* says, "his long and honorable term of service is its own undisputed and best testimonial to his capabilities for the position." The cemetery covers ninety acres and has always been conducted on the lawn plan. One of the principal attractions is the beautiful memorial chapel and conservatory illustrated in the Lord & Burnham Co. advertisement.

No park or cemetery superintendent's library is complete without a copy of Prof. Bailey's "Horticulturists Rule Book." The third edition of this valuable compendium of useful information has just appeared.

RECEIVED.

By-laws, Rules and Regulations of the Lake View Cemetery Association, with Historical Sketch. Calumet, Mich., 1894.

Directory of the Paths, Avenues, and Lot Owners of Pine Grove Cemetery, Lynn, Mass.

Copy of "Bill for an act to establish a department of public parks in cities having more than one hundred thousand population, according to the last preceding U. S. census, and creating a Board of Park Commissioners, etc. By the courtesy of Mr. Oran Perry, member Board of Park Commissioners, Indianapolis, Ind.

Robert Campbell, Superintendent Cave Hill Cemetery, Louisville, Ky., has favored us with 20 fine photographs of the characteristic features of that cemetery. The set forms quite a comprehensive pictorial description of the grounds and being really fine photographs enhances the interest attaching to them.

TESTIMONIALS.

I look forward to receiving PARK AND CEMETERY with a great deal of interest and inclose subscription for another year. George W. Creesy, supt. Harmony Grove cemetery, Salem, Mass.

I have found PARK AND CEMETERY very helpful in our cemetery work. *E. T. Kilkoff, DeLand, Fla.*

I am pleased with PARK AND CEMETERY in its new form. Can't do without it. *Joseph Sharp, supt. Oakland Cemetery, Princeton, Ill.*

We appreciate PARK AND CEMETERY very highly. *Asa R. Taber, Secy and Supt. Maplewood Cemetery, Springville, N. Y.*

I prize PARK AND CEMETERY very highly. *J. T. Buck, Landscape Engineer, Cardington, O.*

We think a great deal of PARK AND CEMETERY. *R. D. Boyce, Sec'y and Treas. Oakland Cemetery, Geneseo, Ill.*

No cemetery official would be without PARK AND CEMETERY if he knew what valuable information he was losing. *Mt. Hope Cemetery, Chicago.*



# PARK AND CEMETERY.

FORMERLY THE MODERN CEMETERY.

A Monthly Journal Devoted to Parks and Cemeteries.

R. J. HAIGHT, Publisher,  
334 Dearborn Street, CHICAGO.

Subscription \$1.00 a Year in Advance. Foreign Subscription \$1.25

VOL. V. CHICAGO, AUGUST, 1895. NO. 6.

## CONTENTS.

EDITORIAL.....	91
LANDSCAPE GARDENING.....	92
*FRANKLIN PARK, BOSTON.....	93
*MEMORIAL CHAPEL, UNION CEMETERY, FAIR HAVEN, CONN.—ROADS.....	96
*FERN HOUSE, HORTICULTURAL HALL, FAIRMOUNT PARK, PHILADELPHIA.....	98
CEMETERY ACCOUNTING.....	99
*SWAN POINT CEMETERY, PROVIDENCE, R. I.....	100
*GREENHOUSES—HOW TO BUILD. VIII.....	101
GOOD BEQUESTS—TRUSTEES OF CEMETERY PERSONALLY RESPONSIBLE FOR NOTES.....	102
RIGHT OF ADMINISTRATOR TO BUY PLACE OF BURIAL—CONTRACT OF PURCHASE MUST BE IN WRITING—CARE OF FOREST TREES.....	103
*FRAGMENT OF A MONUMENT IN ITALIAN CEMETERY	103
EPITAPHS.....	104
THE CEMETERY SUPERINTENDENTS' CONVENTION.....	104
PARK NOTES.....	105
CEMETERY NOTES.....	106
RULES AND REGULATIONS—CORRESPONDENCE.....	107
EXTRACTS—PUBLISHER'S DEPARTMENT.....	108

\*Illustrated.

ON another page will be found the program of the Ninth Annual Convention of the Association of American Cemetery Superintendents, to be held at Richmond, Va., next month. The work of the meeting may be gleaned from the program, and it will be observed that many valuable papers are to be read. The effect of the work of this association is apparent throughout the country, a fact which is appreciated by many cemetery associations who appropriate funds for the expenses of their superintendent at these annual gatherings. This should be the policy of all progressive cemeteries, for it is a paying one, and from the fact that the meeting this year at Richmond, brings it within reach of the principal cities of the south, it should stimulate interest among cemetery officials in that section.

AN excellent idea is suggested in the annual report of the trustees of Public Reservations of Massachusetts, a body incorporated by the State to acquire, maintain, etc., beautiful and historic places and tracts of land within the common-

wealth for the enjoyment of the public. It is the dedicating of beautiful natural or historic places under perpetual trust to the people as memorials to the departed or to perpetuate great names. Such benefactions would obviate the necessity of costly monuments, and would serve a purpose wider by far than any monument *per se* could possibly serve, and would in all human probability outlast any thing the most lavish expenditure could secure. The gift so suggestive was that deeded to the corporation above named in memory of a daughter and named after her Virginia wood. This property is situated in Stoneham, and is an inherited grove of forest trees,—a quiet natural picture worthy of permanent preservation.

A MEETING is about to be held in Syracuse, N. Y., consisting of the representatives of the various cemeteries of Onondaga County, for the purpose of organizing a county cemetery association, whose object shall be the improvement and care of cemeteries and the preservation of valuable historical records relating to these cemeteries. A constitution has been drafted for action at the meeting. The clause in the proposed constitution governing the objects of the association is as follows: "The objects of this association shall be the historical preservation of printed and manuscript records of county cemeteries; the collection, use and preservation of a central cemetery library; the preservation of graves and memorials of pioneer settlers; the care of the graves and monuments of soldiers; the collection and dissemination of information as to the best methods of organizing, caring for and improving cemeteries; and awakening a proper public sentiment in regard to these and kindred memorials of our buried dead." Further details are given, but suffice it at present to say that, there are points in the proposition worthy of high commendation, and a possibility of working out in detail ideas, the library idea for instance, in such a county scheme which would be practically impossible in any other manner. It may be expected that great good to the cemeteries and communities of Onondaga county will result from this move. Mr. W. W. Newman, the promoter of this scheme, informs us that Prof. Bailey is to address the forthcoming meeting.

NOTHING denotes the march of progress more positively than the increased attention given to the health and comfort of the masses, and



happily the result is the same whether it be viewed from the standpoint of philanthropy or civic expediency. Authorities have always held that parks exert a large influence on the health of crowded communities, and there are few cities of importance in the civilized world that have not had parks and public recreation grounds for the greater part of their existence. But these larger parks are usually situated in localities of comparatively light population, and the surroundings have been absorbed by the class for which the park, theoretically, was never intended. It has been taken for granted that the attractions of the park would draw that part of the population most needing such a change to it, wherever its location. This idea has only been partially realized, the economic conditions controlling the dense population precluding its consummation. This fact has now concentrated attention on the providing of breathing spaces and beauty spots, otherwise small parks, in the crowded neighborhoods of our larger cities. We say necessity, because it is today recognised that the moral and physical conditions of the masses are the most important considerations of either municipal or general government, and among the benefits bestowed on the people, none have given more valuable returns than small parks where such have been provided. Sufficient care, however, has never been expended upon them, they have been largely considered play grounds, and hence neglected; but a new decree has gone forth, and we may expect to see, as we should, these small parks places of real beauty, as much, or more care to the acre, given as in the great parks, and kept up so that at all times and seasons of the year, besides affording that much needed breath of fresh air to a tired population, they may be pictures of natural beauty to be stamped upon the uncultured mind and so tend to elevate mankind.

#### Landscape Gardening.

At the meeting, last year of the Illinois Chapter of the American Institute of Architects, Mr. Thomas Hawkes, member of the chapter, read a paper under the above title, in which he discussed the relations which should exist between Architecture and Landscape Gardening; and from which we take some extracts.

After briefly referring to the many examples recorded of such work in by-gone ages and carrying the question along into more recent times, he continued: "The arch enemy of landscape gardening is utility, that utility which signifies greed or a pecuniary profit, but those even who are swayed by it lose not the love of nature or the beautiful, even as they grow older and become more and more im-

mersed in business, for these same persons decorate their houses to the extent of their means, take pleasure looking at the landscapes of their pictures, enjoy the scenic descriptions of the writer, and seek in summer in the country the most beautiful natural scenery that is accessible. The question is not so much to show how landscape gardening should be done as to show how a desire may be awakened to bring it to our doors; to show how this utility may be done away with, this Gorgon that, in cities, turns the innate desire for natural beauty into stone, and which extends its petrifying influence into country homes. But how is to be shown the way by which this utilitarian enemy of the beautiful in nature may be led off? I know of no better method, for a beginning, than that of making of all architects landscape gardeners."

Referring to the gardening of the Persians and the Romans, in the latter instancing among other references the Bay of Naples and its villas, he says: "Passing from that time, the art of landscape gardening seems to have been nearly lost with the fall of the Roman empire, but the splendor of imperial and private gardens, though dimmed, and may be not so fragrant, was preserved by those monks who so well, too, preserved from oblivion the writings of Greece and Rome. Believing that a thing of beauty is a joy forever, in more than an ideal sense, these monks perpetuated the art of landscape gardening in the careful selection of sites for monasteries and abbeys. All Italy then wooed with fragrance and beauty, revived an art, the effect of which has been felt ever since, and which is strongly shown in the French style, a modification merely of the Italian, and later on the Dutch, although fantastic in many essentials, with their level grounds, their formal terraces, their canals and straight tree planting, helped to form the natural style of the present day.

In Europe there is evidence everywhere of an inclination to the art, and in many places the evidence of masterly skill is pronounced, but principally in England has the practice of landscape gardening received the greatest attention. Wealth there, by reason of its concentration to a few, has been expended in vast sums on such work, which, embodying the merits of previous successive changes and eliminating false styles, has through the efforts of various professors made landscape gardening to be more understandingly practiced than at any time in the past. In the eastern parts of the United States, at places the art is much practiced, and here in the West there are many fine samples of it which excite our admiration. Shall we here call to mind a recent splendor that is past, a relative perfection of artistic gardening whose aid contributed so much



to the architectural beauty of the Columbian Exposition? Can we think of it, now that it is past, without its esplanades and "Wooded Island," its lagoons and water courses, its fountains and its statues? If we cannot do this, can we help admitting that without these accessories its beauty would have been but dimly shown, if indeed there would have been beauty there at all? This perfection of landscape gardening, this universality of its scope that imagination saw the possibility of in miniature, charmed the eyes of millions.

This art of landscape gardening, which should be encouraged by the wealthy and studied and practiced by the architectural profession, is of the utmost aid in obtaining noble architectural effects, and is, whether ranked so or not, above all the arts for its capacity in being able in proper harmony and design to enhance to the eye the appearance and value of a building. It is greatly educational, and consequently more beneficial than the results of the skill and genius of the artist, because while they are appreciated only by the profession, the work of the landscape gardener is a living picture made of nature's own materials adorned with its ever-varying beauties of hues and tints as unlimited as the variety and diversity of tree forms, shrubs, ferns and grasses, and it is susceptible to the comprehension of all and so is an art preeminently that refines the mind and gratifies that innate longing which most of us have for the beautiful.

As I have before expressed that the landscape gardener should be an architect, I must assert now that no landscape can be properly taken advantage of or modified, that no landscape gardening can be rightly done without a knowledge of architecture, for how can one make a landscape harmonize with the building and vice versa, if he lack the knowledge of architecture? Landscape gardening also requires no slight acquaintance with engineering, because a practical knowledge of the use of materials will be required, as also that of leveling, depressing or raising the grounds; but an engineer alone, or an architect who is only such, will treat landscape gardening from no other view than that of the profession, and one who is a gardener merely, no matter how skillful he may be in the cultivation of plants and flowers, will have the aim only to display them, and it will follow that congruity and simplicity in all these cases will give way to novelty and picturesque effects, which are two qualities only of landscape gardening. Intricacy is to be studied in the laying out of the grounds, and it must have the quality of variety. Simplicity must contrast with grandeur; novelty must give it animation; association must endear it, and all must be bound in continuity. These effects can be best

achieved if the landscape requirements be studied before the planning of the building is definitely made, but they can very seldom be attained, and if so, in a modified form only, if the structure is erected and the grounds considered afterward. \* \* \* Of course, in all this there is more to be studied than the immediately contiguous scenery; the characteristics of the ground and the neighboring scenery must be taken into consideration; the character of the soil, and, too, to arrange the relative positions of the different buildings. Drainage, also, must be taken into account. Collaterally to landscape gardening the finest views for the different rooms are to be studied, and by so doing avoid the frequent case of presenting the worst views from the best rooms of the house, and vice versa. A little thought in this matter will so arrange that natural or artificial beauties shall be seen from other rooms than those which are reserved for very indifferent purposes. \* \* \* As much as I have in the beginning of my address berated that very useful quality, utility, it must be considered in the long run. Under the head of utility may be mentioned that were the landscape gardener consulted in the first place the money paid for his services would be no small part of the saving effected, for, taking advantage of the conformation of the grounds, he avoids expensive so-called improvements.

What is the occasion of the rectangularity of our towns, so rectangular that a curve would seem to be an offense? Surveyors lay out our towns and villages in checker-board fashion. Streets are projected in impossible places, building lots are often inaccessible, and drainage is bad, making necessary an ant-like process or excessive expense to cut down the natural hills. These evils seem never to be at first noticed, or, if they are, they are not considered, because shortsightedness, under the name of utility, wishing to make the greatest number of lots, does not see that were the natural advantages of the ground considered our towns would be better in all respects instead of being ugly for all time. There is a possibility, though, that these matters may be more generally observed, and that the future holds out some hope, for, as fast as we have developed it, the whole country is not yet quite subdivided.

#### Franklin Park, Boston.

Parks, like individuals, possess distinct characteristics and why should they not, since every park bears the imprint of individual hand, and the comparatively new parks in and about Boston are pronouncedly marked in this special phase. Franklin Park has deviated but little from the plans set down by F. L. Olmsted, Landscape Architect, a dozen years or more ago. The Arnold Arboretum is dis-





TENNIS COURTS—FRANKLIN PARK, BOSTON, MASS.

tinctly the reflection of Director Sargent's eye and mind, Lynn Woods evidences the fostering care and sentiment of Mr. Chase, and so on. Usually the original movers or inceptors of these glorious openings or "breathing spaces" inspire the community with enthusiasm for the earnest taken in the peoples welfare and I fail to find any mercenary motives of consequence which actuated the founders or workers in our present Park System.

Franklin Park differs from Lynn Woods as much as Lynn Woods differs from the Arboretum. The former is effeminate, Lynn Woods, masculine and the arboretum a delicious sylvan retreat. The Middlesex Fells, Blue Hill and other sections of our woody reservations all possess beauties quite individual, and the guiding hand of Baxter, the instigator of the Metropolitan Park Commission, and Devenport in his poetic words and efforts help to keep the former park simple and rural.

It would be hard to say which of our parks are the most interesting, each one is a jewel set in the breast of Nature's mantle. When I return from Franklin Park after an early morning's walk, I am filled with the sweetest sensations. It is a poetic, receptive, gentle park, even the "Out look" and "Wilderness" do not shake off my aesthetic drowse, nor do the glacial boulders of pudding stone formation, which rise like giant heads here and there, alter my impressions. The tangle of ivy, the wild shrubbery, the massive sweep of the rocky facades, which force the hard, smooth white drive ways to curve, and sway in another direction, these suggestive evidences of natural accessories to those applied, do not disturb the tranquility of my mind, which the coquettish park has given me. I am

subdued and quiet, the quest for the robust in nature does not occur here, nor was it intended that it should, as one may easily discover if he will but wander over the precincts, and as the space allotted for this article is too small for details, a drive will disclose the salient features of Franklin Park.

The Park is named for Benjamin Franklin for the following reasons:—By the will of Dr. Benjamin Franklin approved in 1791, he directed that the sum of money left by him to the town of Boston (one thousand pounds), and known as the Franklin Fund, should be loaned at interest, and allowed to accumulate for one hundred years, at which period he estimated it would reach the amount of \$655,000. Of this sum the trustees at that date (1891) were empowered to lay out \$100,000 in some important public work or works, and the balance of the fund should again be put at interest and allowed to accumulate for one hundred years, when the town of Boston was to dispose of a portion of the fund and the State of Massachusetts to use the remainder. Owing to the various causes the fund was not very productive in its early years, or it would have reached a larger figure than it now exhibits. Its annual growth at the present time exceeds \$10,000. The sum \$388,000, of which the city took for the purpose of developing Franklin Park about \$290,000, the remainder being placed at interest.

From the Blue Hill avenue entrance, the largest of six, which spreads out its enticing broad arms of welcome, one obtains a glimpse of the proposed Deer Park of eighteen acres, on a rising gentle slope to the right of the carriage stand. Then comes the "Greeting" with nineteen acres in process of completion, and from this point we gain an



extended view of the city and country park, its lay out and general composition, both of plain, roadway, upland and foliage contour. From the "Overlook" rustic building, a good view of the play stand is secured, with its thirty acres of delightful greensward, playing ground for children. Leaving this healthful locality, we cross the "Old Trail Road" or Indian foot path used by our Pilgrim fathers in their communications between Plymouth and Boston.

By the Valley Gate we enter the Country Park which is not used at night and is distinct from the City Park which is illuminated with electricity. Of course the rural aspect of the country park also marks its special use for it is, aside from the "slick roads," very simple and natural in its undulating formations

At various intervals one encounters specially beautiful spots, such as the bridle paths which intercept the road here and there, the road at the entrance of "Rocky Wilderness", the Ladies Tennis Courts with mysterious by paths and walks and sylvan vistas.

From Scarborough Hill, the highest point, (150 feet above the sea level) of observation, one views a marvellously beautiful stretch of country. On the left is Dorchester with its steeples rising above the tree tops, in front nearly a dozen miles away stretches the long range of Blue Hills of Milton, ten miles or more in length, now a part of the park reservation, while the intervals are filled with pasture grounds, rich green foliage, and the towns, Milton, Hyde Park, Mattapan, Ashmont and Quincy.

The Arnold Arboretum, with its daisy field on the slope of Weld Hill, the ancient hemlock woods



LOOKING TOWARDS "OVERLOOK" IN WILDERNESS.

that rise abruptly on its border; Bussey woods so dense and glorious in the soft hazy shimmer of the summer light, these are a few of the distant landscape views that enchant the eye and sooth the mind.

A nearer view discloses the principal features of the park; Schoolmaster Hill with its grottos, vines and pavilions; the grassy field, where three hundred Southdown sheep, guarded by a shepherd and dogs, nibble the freshening blade, form interesting spots on the velvet lawn as they move in bodies or scamper away in frolicsome mood.

From the "Outlook" another lovely view is obtained, not only in the way of perspectives but in foreground as well. Here one looks down a rude-step terraced slope, partly o'erhung with foliage and deep wooded on either side. Color, light, shade, flecks of golden sunrays, the gray old rocks, the gay wild flowers that deck the saucy bush, and the creeping vine, which, like an apron, covers the sober earth, all dance and smile and give you welcome, or as Emerson says they "politely greet you with a How-de-do?" So one might dwell upon the beauties of this five hundred acres of upland public reservation ground upon which nearly \$4,000,000 have been spent. One feels each special spot more beautiful than the imagination could picture, and coupled with the historic features of the whole the mind is filled with love, reverence and inspiration. When one thinks that it was here that America's first philosopher, Ralph Waldo Emerson, lived, sought and wooed the Universal Spirit; that for over two and a half centuries the founders and descendants of American civilization have enjoyed these rural glories; that Gleason, the publisher, strove to make his pictorial efforts unequalled, it is not to be wondered at that this park should be celebrated.



SYLVAN "OVERLOOK." WILDERNESS, FRANKLIN PARK.

By the practical completion of the Parkway, the



public is provided with a continuous driveway all the way on park land from Boston Common and Public Gardens to Franklin Park, a distance of seven miles. The entire length of park way drives is eleven miles, this added to the Park and Arboretum drives makes a total of twenty miles thrown open to the public which is one tenth of the Metropolitan Park System.

I might mention the beauties of Scarboro Pond alive with canoeists, its marge of tree reflections, always a feature in landscape and in the rural sense, not when bounded by hewn and designed stone; then there are innumerable picturesque bits, fine masses of tangled scrub and shrub, cultivated road lawns where the bicycles meet; verges of green area which claim attention from the rider or plodder on foot; architectural effects, for architecture is here made effective in juncture with the landscape, noticeable in the Refectory building and its rustic retaining wall elevation crowning the old Gleason grounds. Dales that demand a halt to contemplate as one would an innocent face among the promenaders at a dress ball, or the comely maiden in the Sunday village church procession; flora so varied and decorative; the roadside rose, laurels, brooches and clusters of azaleas, rhododendrons bursting into effulgent glory, varieties of kerrias bloom, and other multitudinous blossoms and flowers, scent the air and flood the fore-grounds with their brilliant hues and glances.

Such are a few of the charms of Franklin Park, and these beckon the dwellers in our brick wilderness to enjoy its vernal mildness, its reason, faith and perennial attire.

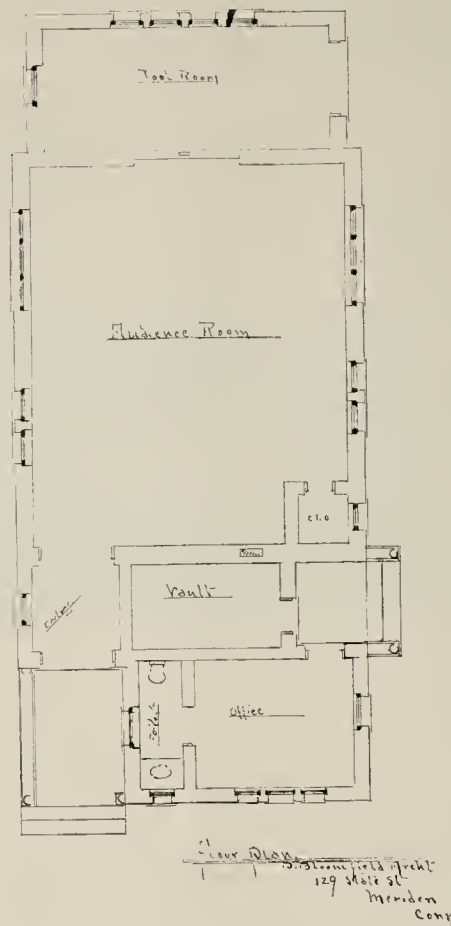
*F. T. Robinson.*

#### Memorial Chapel, Union Cemetery, Fairhaven, Conn.

The accompanying cuts give perspective elevation and plan of the Memorial Chapel, now in



CHAPEL, UNION CEMETERY, FAIR HAVEN, CONN.



PLAN OF CHAPEL.

course of construction, at Fairhaven Union Cemetery, Fairhaven, Conn.

The exterior will be constructed of East Haven, red sand-stone, rock-faced, broken ashlar; with metal work,—crestings, valleys, flashings, gutters, conductors and finials of 16 oz hard rolled copper. The roofs will be of slate.

The interior side walls of all rooms except tool room, will be of buff colored brick. The ceilings will be plastered with Adamant and tinted with water colors.

The ceiling of the vault will be arched with hollow brick: the inside finish will be of North Carolina pine. The floors of all rooms, except the loggias, tool room and vault, which will be vitrified brick, will also be of North Carolina pine.

Stained glass, costing some \$1500, will be used in all the windows. Exclusive of glass the contract price for the work was \$5285. The architect of the structure is Mr. D. Bloomfield, of Meriden, Conn., and the contractors, R. Redfield & Son, of New Haven.

#### Roads.\*

When ground is to be prepared for a cemetery, the first question that arises in regard to roads is one of location. The answer will be determined by considerations of beauty, utility and economy. If we were only seeking to produce a beautiful cemetery we should have trees, shrubs and flowers so arranged on a perfectly kept lawn as to produce the best effect of light, shade and color. The lawn would cover what Downing so pleasantly described in his essay on 'The Beautiful in Ground,' and among the trees would stand a few monuments that would be real works of art. But utility demands that we shall be able to ride in carriages to points

\*Read before the Association of American Cemetery Superintendents at Brooklyn, N. Y., 1888. By O. C. Simonds of Graceland Cemetery, Chicago, Ill. Revised to date.



within one hundred and fifty to two hundred feet of every lot in the cemetery, and to meet this demand it is necessary to replace certain portions of the lawn with roads. These should go with reasonable directness from the entrance to points in the vicinity of each lot, and we should be able to get from one drive to another without having to go too far around. Economy, as well as beauty, requires that there should be as few roads as possible, while complying with the conditions stated.

The general result will be that the cemetery will be divided into sections, having a width of about three or four hundred feet and having the longer axis radiating from the gate. This result, however, will nearly always be modified by variations in the surface of the ground, bodies of water, trees and shrubs, or to take advantage of pleasant views or shady groves. The drives should rarely be straight, curves being more pleasing in this case, just as an undulating country is more beautiful than a flat one or a winding river than a straight canal.

When going over hills and through valleys, we are always anxious to get to the highest point ahead, in order to get a new view or satisfy curiosity in regard to what is at present hidden. When riding on a boat in a river, we have a similar feeling about the next bend. So in riding along a curved driveway in a cemetery or park, our curiosity is aroused as to the new objects which each moment brings in sight—here a monument, there a group of trees or shrubs, then a lake or river, a bed of flowers, a majestic elm or a pleasing vista.

Since it is necessary to have roads, the curves themselves should be elements of the beauty of the cemetery. They should lead in the most natural manner to the point you wish to reach, avoiding double curves and circles as far as possible. Perhaps the most satisfactory curve is the long sweep, which loses itself in distant foliage.

I always lay out a drive on the ground first, and then survey and plot it afterwards. The line on the ground is indicated by a number of small stakes, which are rapidly placed in the ground while walking, approximately on the line that is to form one boundary of the roadway. The exact location of this line is then determined by sighting along the row of stakes, while an assistant passes from one to another, moving it to the right or the left until the curve is satisfactory. Before it is pronounced correct the curve should be viewed in each direction from all points along the future drive. The opposite side of the roadway is then determined by simply measuring across from the stakes mentioned, the distance chosen for the width of the road. This may be any distance between twenty and thirty feet, the proper width depending on the

amount of travel the road will have to bear.

I have said that the general plan which has just been outlined, will, in most cases, be modified by features characteristic of the locality. It is desirable that the driveway should not rise more than about one foot in twenty. If there are steep hills they will of course affect the location of the road. Perhaps it will be necessary to have it ascend a ravine or wind back and forth along the hillside, in order to reach another drive with which connection must be made. In Spring Grove Cemetery two large elms, whose branches formed a natural archway, determined the place of one of the avenues. In an other place a huge limb projecting from a venerable oak caused the spot beneath it to be chosen as one through which a new drive must pass. In a leading eastern cemetery a road is so situated as to make a range of blue hills the principal object in the landscape.

Rivers and lakes must always be considered in laying out a drive in a cemetery where they are found, and a group of trees or shrubs which would increase the attractiveness of any scene, might be a sufficient excuse for making the actual curve on the ground vary from one that an engineer would draw in his office.

Having decided on location, the next question that arises is one of construction. This subject is treated so fully in works on engineering, that are doubtless accessible to all of you, that I will only refer to it briefly. At Graceland it was necessary to study economy in making the roads. The soil was a light sand. No stone could be found in the vicinity and only lake-shore gravel which had no cementing material. Clay could be delivered on the ground for eighty-five cents, and the gravel mentioned for one dollar and a quarter per cubic yard. After grading the road bed so that it would be slightly higher in the middle than at the sides and have a variation lengthwise of from one to six or seven feet in one hundred and twenty-five, clay was spread on in a layer averaging six inches in thickness.\* The clay was put on a little thicker in the center than at the sides, and was thoroughly rolled with a five-ton roller, the edges of the clay bed were rolled first, and our aim was to have the top surface consist of two planes, having a lateral slope of about one in twenty, connected in the middle by an arc about five feet in length.

A layer of gravel was then spread on the clay and rolled. It was found best to have this layer less than an inch in thickness. Of course, as the

\*We now use slag for the first layer making this layer seven inches thick in the center and five inches thick at the sides. On this two or three layers of broken stone aggregating four or five inches in thickness are placed, each layer being thoroughly sprinkled and rolled. June, 1895, O. C. S.



frost went out of the ground in the spring, much of this gravel would disappear in the clay, but a new layer was then put on and rolled as before, when the road would remain good the balance of the season. After putting on a few layers of gravel, a layer of broken limestone about two inches thick was put on part of the roads. The limestone comes from quite a distance and costs a little over two dollars a cubic yard. The clay has not worked through this limestone, and the surface has been hard and smooth like that of a macadamized road. Such a surface, it seems to me, is the most suitable one for a cemetery. Carriage wheels in passing over it do not produce such grating sounds as on gravel, nor the horses' feet such a clattering as on asphalt. With a firmer soil for a foundation and stone on the ground or in the vicinity, I should advise the building of the ordinary macadam road, which is made up of successive layers of broken stone, the lower layers being coarse and the upper fine—each layer being thoroughly compacted by wetting and rolling. In many places where there is a good packing gravel, motives of economy may dictate its use. In such cases there will generally be a saving of expense by screening the gravel before it is hauled from the pit, and the result will be more satisfactory.

The drainage of a road is nearly as important a matter as the material of which it is composed. When the ground is high and the soil, sand or gravel, the underground drainage needed in other cases can be dispensed with. Where a road passes over a bed of muck or peat, this material should be removed before doing the grading. The surface water should always be taken care of. On steep grades gutters are necessary to prevent heavy rains from washing out the road bed, and frequent catch basins are needed to prevent the accumulation of too much water. A catch basin should be made so as to guard sewers or drains from anything that might tend to choke them. The ordinary cast iron catch basin cover has been used in Graceland, but the leaves accumulate on it during showers and sometimes prevent the water from entering.

In Spring Grove the covers are made of stone and placed just outside the line of the gutter, with a large opening underneath for the entrance of the water. The gutter sometimes forms a part of the lawn, and where there is not too much water, this gutter is a very good way, but usually the gutter is made of stone.

The margin of the road can very properly be considered in the time devoted to this topic. Mr. Strauch said that the surface of the ground each side of an avenue should be tangent to the surface of the driveway, so that it would appear as though

the sods had simply been removed to form the road. It is this simple rule which gives the drives he made such an elegant appearance. In many cemeteries the sod where the ground rises above the gutter is convex, forming a shoulder, which it is almost impossible to keep neat and true. In others it is six, eight, and even ten inches higher than the adjacent gutter, instead of being, as it should be, not over two inches.

Finally, the roads when completed should receive constant care and attention. They should be sprinkled during all dry and dusty weather. No ruts should be allowed to form. Weeds should not be allowed to grow there or anywhere else. All leaves, branches of trees, grass cuttings, sand, dirt, papers, etc., should be at once removed so that the cemetery will always present a neat and tidy appearance.

#### Fern House, Horticultural Hall, Fairmount Park, Philadelphia.

Horticultural Hall, Fairmount Park, Philadelphia, is one of two of the large buildings erected during the Centennial which were left standing. It occupies a bluff that overlooks the Schuylkill



INTERIOR OF FERN HOUSE.

river, 100 feet below. This great conservatory is 380 by 193 feet and 55 feet high, perhaps the largest building for this purpose in the country. On two sides of the main building are extensions, one of which is known as the "Fern House" a partial view of the interior of which is presented herewith. There is a great deal of attraction in ferns, and in many public and private places it is not uncommon



to find houses especially to accomodate them. Moist atmosphere and warmth suit all ferns, but they do not require the great heat by some thought necessary.

Although the plants in Horticultural Hall are in a thriving state, as can be seen in the illustration, the house itself is not of the best construction for them. The roof is of iron, and it condenses moisture quickly. This moisture is apt to drop on the foliage of the ferns, there being no provisions made for carrying it to the ground, and in this way the foliage is sometimes damaged. But the watchful care of those in charge has resulted in the production of some very fine plants. Some of the older ones such as the *Alsophila australis* and the *Cyathea dealbata* have had to be sunk several feet in the ground, as they became too tall for the structure.

The most of the ferns in this house are planted in the ground. But few excepting some of the choicer kinds are in pots. Although fibrous peaty soil is good for ferns, it is not deemed essential, as it used to be. Ferns have fine hair-like roots, and in common with all similarly rooted plants they must have light soil. In heavy soil the roots cannot penetrate, air cannot be carried through the soil by water, and the plant becomes diseased. The round headed clumps of foliage seen in the picture are old stumps which have been covered with the creeping fig, *Ficus repens*. This is such an excellent self climber, that for the covering of walls of greenhouses or similar purposes it is much used.

The interest in ferns shows itself not only in the erection of houses for them, but in the use of hardy sorts in ornamental gardening outside. Perhaps the common evergreen fern, *Aspidium acrostichoides*, is the most valuable and the most used of all for the purpose. Its bright green fronds at all seasons of the year, its hardiness and adaptability to all situations, make it the first to be called for. Another evergreen one of large growth and much beauty is *Aspidium marginale*. I have not found it necessary that ferns be in absolute shade. They will take a little morning sun without injury. What they want is light and moist soil. A mound or any depth of soil in which forest leaves have been largely used is an excellent place for them.

Joseph Meehan.

#### Cemetery Accounting.

Cemetery accounting like that of other business will also vary in like manner; simply because the volume of business necessitates more or less bookkeeping, and more or less intricacy of detail, just according as the accounts are complicated and vary in the conditions attaching to them. In small

cemeteries but few books will be required: cash book, journal, ledger and receipt book with stubs being ample for the business transacted, and little more will be required for cemeteries of larger size and importance for the ordinary business transactions, where lots are sold for cash. Where cash of some amount or other is made obligatory with every order, the receipt book with stubs answers for a record of the details of such order, as well as the first entry of cash and the accounting can then be carried through in the regular way either of single or double entry bookkeeping. The prime necessity is that the condition of the cemetery affairs should be readily understood by its owners at any time, and reports be available with little delay.

Generally speaking, however, more detail is desirable, and both the income and expenditure should be classified and subdivided, so that under the several necessary heads the amounts due to each may be properly booked, with the result that the record of each department can be examined and adjusted, and the best possible conditions of economy realized by due attention to the facts presented. To secure this all available data must be arranged in such a convenient manner, that comparisons based upon all the facts connected with each department may be readily made. The several departments, are, however so interrelated that absolute accuracy cannot in all cases be assured, but sufficient knowledge of the conditions in each case, for all practical purposes, will be available.

In addition to the ordinary books as already suggested, there will be required a record of interments in which all the necessary information regarding the deceased should be kept, and a lot book showing a diagram of each lot and the correct location of grave, monuments, etc.

An accurate record of all deeds should be kept in permanent form, and in some cemeteries deeds are kept alphabetically arranged with space left for remarks and details of transfers, etc.

These several books vary in detail according to the experience of the officials using them, and the cemetery requirements, but it is always wise to avoid complicated bookkeeping as far as possible and to simplify all the methods adopted.

The following is a form of agreement now in use by the Riverside Cemetery, Cleveland, O.:

**Agreement,** Make this.....  
between the *Riverside Cemetery Association*, and .....

.....  
WITNESSETH, That said *Riverside Cemetery Association*,  
doth hereby sell to said.....  
.....Lot No..... in Section No.....  
in the Cemetery grounds of said Association, in the Township  
of.....Cuyahoga County, Ohio, at and for the  
price of .....



.....Dollars, payable as follows: .....

with interest, at the rate of six per cent, per annum, payable annually; when so paid said Association binds itself to make to said .....

the proper certificate of ownership for said lot.

AND IT IS EXPRESSLY AGREED, That upon failure to make said payments, as above stipulated, or either of them, that said Association may remove the bodies interred therein to any public grounds used for that purpose, and re-sell said lot without re-payment of any installments before made under this contract, to any person willing to purchase the same, and thereupon all rights of said .....

under this Contract, shall cease and determine.

AND IT IS FURTHER STIPULATED, That in case of failure to pay the whole or any installment of said consideration money, such legal proceedings may be had to compel payment as are usual in the case of ordinary land contracts, and if a judicial sale shall be had, the Association to have the same right to remove the bodies as in the case of re-sale, without legal proceedings.

WITNESS, The signatures of the parties aforesaid, hereto affixed, the day and date first above written.

RIVERSIDE CEMETERY ASSOCIATION.

By .....

This subject will be continued in the next issue by a paper on "Cemetery Accounting" read at a meeting of the Association of American Cemetery Superintendents.

#### Swan Point Cemetery, Providence, R. I.

To see this beautiful place of sepulchre at its best, pretty as it is at all times, a visit should be made early in the month of June, when the flowery



THE BOULDER WALL, SWAN POINT CEMETERY.

shrubs are in the midst of their glorious wealth of bloom.

In the treatment of Swan Point, Mr. McCarthy has departed from the usual course of planting observed in most cemeteries, and almost exclusively makes use of shrubs for ornamentation. The dis-

tinctive character of the planting will be a lesson to the great majority of cemetery officials, who cannot fail to be benefitted by a visit to Swan Point; for turn in any direction a contrast is presented.

In some portions of the grounds, the visitor will come across what at first appears an indescribable jumble of shrubs as if thrown together by nature in all her profusion. Yet here lies the work of the true artist, the blending of nature and art so completely as to give the appearance of the planting that of nature's handiwork. Azaleas, Laurels, and Rhododendrons were fairly ablaze in their glorious wealth of many colored flowers, and the contrast of color and variety of bloom and foliage was magnificent. The grouping is so arranged that the view from any standpoint is varied, and after a look from the high ground above, or the low lands below, where the high boulders and rough stones can be seen peeping up, or standing out boldly among the shrubs and partly covered with Euonymous or other creepers, makes the observer doubtful as to which is the most charming sight.

Turn where you will in Swan Point, the scene is ever changing, and the views delightful, the rolling and generally sloping character of the land greatly assisting in this object. When on the high land looking towards the Providence River, the picture is so pleasant as to create a desire to immediately go down to so charming a spot, but on reaching the pretty drive which runs along the bank of the stream a glance upward at the high lands brings on a change of feeling and a desire to reoccupy the beautiful spot from which so commanding a panorama was to be secured. Swan Point is a place where the true lover of nature can never tire of visiting.

In doing his work Mr. McCarthy has many difficulties to contend with. For instance: the land is full of immense boulders, all of which have to be removed before the burial sections can be used; some are too large for removal and have to be left on the surface and utilized for ornament; these are planted around with shrubs and partially covered with vines, the smoothest face of the stone being left to answer the purpose of a natural tombstone for the lot immediately in front. Here again

is the work of the true artist.

A high boundary wall, composed of great boulders, is under construction, wherein no cement is used, the weight of the stones being sufficient to hold it together. Along the front, and in this wall, a profusion of shrubs and creepers have been plant-



ed, that will, before many years elapse, form a wonderful and picturesque mass of vegetation and rock-work.

In Swan Point are two small pools of water; for they cannot be designated by the title of lakes. But, oh! how enchanting and fairy like! They would require a more poetic pen than the writer's to describe. The rocky walls (boulders) seem as if placed by the hand of nature ages ago. The trees and shrubs seem as if kissing the water, while the lights and shadows are marvelous. The photos of these beautiful bits of water fail to give anything like an adequate idea of their quiet and dignified beauty.

A few copings around burial lots are still to be seen, but Mr. McCarthy tries to make the best of them, hiding their stiff and formal appearance by planting Euonymous and dwarf plants along the front of the most visible portions, an idea worthy of imitation.

While giving every credit to Mr. McCarthy for his artistic ability, yet it must not be forgotten that nature has been most bountiful in supplying climate conditions that enable him to perform his charming work. To use his own word, "The locality of Swan Point is the natural home of the Laurel, Azalea, Rhododendron and other evergreen trees and shrubs." He is thus able to raise from seed thousands of young shrubs which in many other places it would be impossible to do. Still the object lesson is there. Plant more shrubs and low growing trees and do away with the forest-like appearance of too many of our cemeteries.

*Bellett Lawson.*

**Greenhouses.—How to Build. VIII.**

The intermediate posts are next set across the ends in proper line. The end posts of the 6 inch rows should have been flattened on the south side to receive the sheathing, before having been set. The south door jambs are now to be set. They should be plumbed carefully each way, mitered at the top to receive the gable end bar to which they are nailed. They are also to be nailed to the posts beside them. The door sill and upper piece of the frame are then put in, but the doors are not hung until the house is finished. In setting the jambs care must be taken to have the north edge of the groove for glass in their sides, meet exactly the same edge of the under glass groove in the end bar (Fig. 14-2.)

The end wall plate is then to be set. It is carried on the top of the posts after they are cut off

square to the proper height.

Fig. 15 is a section of the end wall plate, part of vertical bar and part of wall. 14 is the plate, resting on the post, 15 ship lap, 16 drop siding, 13 is the end bar, 4 its tongue and 1 the vertical glass in place.



FOUNTAIN, SWAN POINT CEMETERY.

The shoulder in the plate against which the glass (1) rests must be directly under the north edge of the glass groove in gable end bar (Fig. 14-2) and must accurately meet the north edge of the glass groove in the door jambs. The east end of the

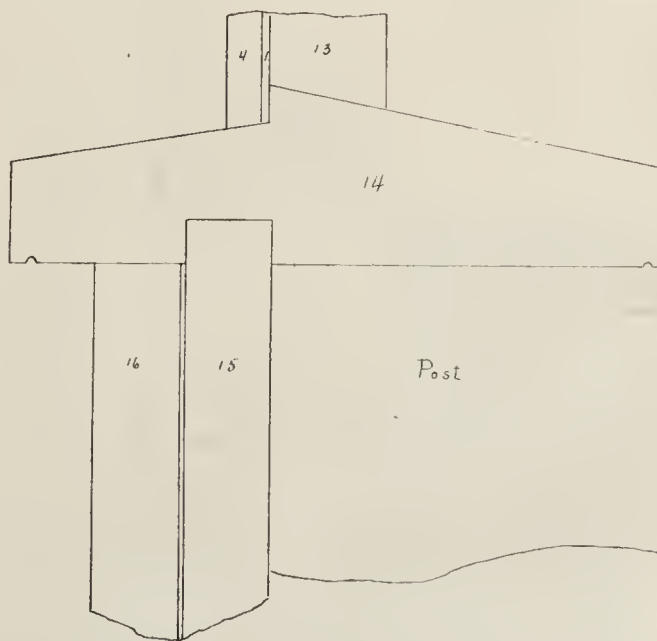


FIG 15.

plate is fitted against the gutter sill, its upper angle touching the lower side of gable end bar. It runs across from there perfectly level and makes a square joint with the side of door jamb.

It is then run from the other side of door to opposite gutter sill (or plate, if used) after which the



wall below it is sheathed up in the same way as the side walls.

The vertical sash bars are then set using the gauge above and below as on the roof, working each way from the door as a starting point. The lower end is first cut as shown. It is then set up, the gauges applied and it is marked and sawed off to meet the under side of the end bar. Care must be taken to have the shoulders on the bar coincide with the north edge of the glass groove above and with the shoulder on the plate below. They must be carefully cut to the exact length required, otherwise the gable end bar will be forced up or the vertical bar will be out of plumb and the glass will not fit. Vertical bars must be run from the top of the door frame (which should be of the same shape above as the wall plate) up to the gable end bars. The vertical bars need not be so heavy as the roof bars and have no drip grooves. The house is now ready for painting and glazing.

The small house is finished in exactly the same way, except that there are no supports used under the ridge and the bars having a rise of 6 inches to the foot, the distance of the lower edge of glass groove in the ridge *vertically* above the upper angle of gutter sill will be 2 ft. 5 3-16 inches.

In practice the posts for all the north and south walls are first set, then all gutters and side wall plates are put on after which all roofs are put up then the end walls are put in across all the houses

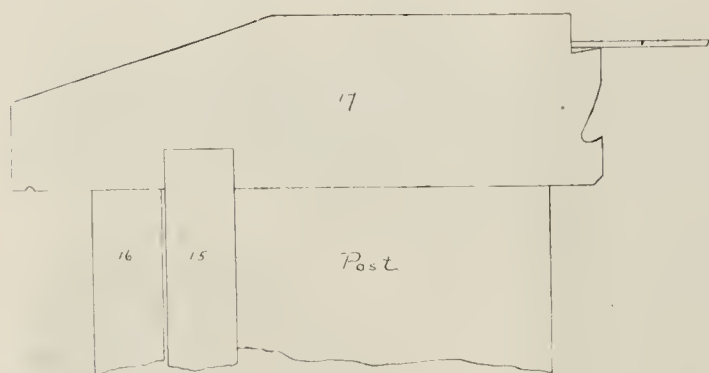


FIG. 16.

after which the ship lap, then the paper and finally the drop siding, are nailed in place finishing with ordinary corner boards at the angles.

The south side of the shed can now be sided down to the end bars and finished, no siding being used ordinarily below the green house roofs.

The propagating house being a very light structure is built with 4 inch posts. The north wall is built with wall plates as Fig. 8 or 9.

As no glass is needed in the east and west walls, a combined wall plate and end bar (Fig. 16-17) is used. 15 is the ship lap, 16 the drop siding and 1 the glass.

The piece (17) is fitted and butted to the north

wall sill, or plate, just as the sash bars are attached in the other houses and is mitered to the side of the shed, the posts being carried up and cut to the proper height and angle to carry it, and the sheathing is carried up and into its groove as on other walls. If the upper angle of the north wall sill or plate is 4 ft. 6 in. above ground the upper edge of the shoulder of No. 17 which carries the glass should, for a 6 inch to the foot slope, be 3 feet 1/2 inch higher. If the shed is high enough it will be well to make this 6 or 8 inches higher still. After the two gable end plates (17) are set, one at each wall, a strip of 7/8 inch stuff is nailed firmly to the shed across from one to the other snug against the under side of each. This will carry the upper ends of the intermediate bars which are now put in place, using the gauges, the same as on the other houses. Only one ventilator will be needed which can be hinged to a strip attached to the shed, a short bar and header being used, as in the other houses. The north side of the shed can now be sided and finished fitting the siding close down on the bars. After the glass is set the space between it and the siding can be filled with putty. Between each bar strips of 3/8 or half inch stuff are nailed to the shed, their upper edges even with the shoulders of the bars, to carry the upper edge of the glass.

The houses will now be ready for the glass.

In the preceding work the builder must measure accurately, plumb carefully, and keep the pot of thick paint handy, when no fears need be entertained as to the result.

*Willis N. Rudd.*

#### Good Bequests.

In construing certain clauses of a will, the supreme judicial court of Massachusetts holds that a trust to keep the burial lot and monument of the testator always in good order is, under the statutes of Massachusetts, a good perpetual trust, and that it can be separated from a trust for other purposes as from one for keeping in good repair an old homestead, both being provided for together, and the latter being void under the law. The courts also holds that a gift of real and personal property for a public park is a good public charitable gift or bequest.

#### Trustees of Cemetery Personally Liable on Note.

A certain promissory note read: \$1,000.00. We, the trustees of the Crown Hill cemetery, promise to pay to Ephraim Caldwell, one thousand dollars for money borrowed of him, to bear 8 per cent per annum. This 4th day of March, 1885. Z. T. Moffett, E. Caldwell, J. M. Brown, E. E. Peck." The writing did not contain a promise on the part of the



Crown Hill Cemetery Company, but, according to the court of appeals of Kentucky, was in law the personal obligation of its signers. Their experience may furnish a suggestion to others who have notes to sign for cemetery companies.

#### Right of Administrator to Buy Place for Burial.

The right of an administrator to purchase a lot in which to bury a deceased person rests on very similar principles to those which control the administrator's right to pay the funeral charges and the expenses which are immediately attendant upon the death and burial. While the administrator has the undoubted right to buy a place to bury the dead in, due regard must always be had to the situation of the estate, to the question of its solvency or insolvency, and to the circumstances attending the expenditure. The difficulty under which the administrator always labors is easily recognized. The stricken relatives are always clamorous for what they consider a fitting place in which to lay the dead, while the administrator is largely controlled by the financial considerations which must govern his action. These observations are made by the court of appeals of Colorado in a case where it holds that it was manifestly ill conceived and unjustifiable for an administrator to expend \$1,350 for a burial lot when the estate of the deceased was insolvent and only amounted to about \$5,000, or nearly 25 per cent of all the money which came into his hands as administrator, and that an allowance of \$240 was ample and liberal, under the circumstances, for this purpose.

#### Contract of Purchase Must Be in Writing.

A statute of the character of chapter 501 of the New York State laws of 1881, which provides any incorporated religious society having a cemetery "may sell lots or plats" therein "subject to such conditions and restrictions as may be imposed upon the use of such lots or plats," the Surrogate's Court of Westchester county holds, provides for the sale of an interest in land, and a contract of purchase must be in writing to be binding. Without the aid of the statute, the surrogate states that it may be said that the very nature of the right of sepulture implies a right in land lasting in its character. For no interest in land, other than an absolute title, can there be claimed a greater right of permanency. No one would be presumed to have selected as a place of burial one in which his or her remains could lie only during the pleasure and subject to the whim of a corporation religious or otherwise. The characteristics of a license which is personal and revocable, are repugnant to the idea of a burial place. Here a man had concluded to take a

certain lot at the price of \$450, and paid \$10 on account. Because there was no writing entered into, for the above reasons it is held that the balance of the purchase price could not be recovered from his estate, although on his decease he was buried in the lot.

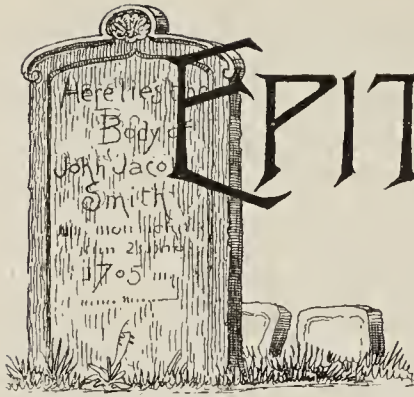
#### Care of Forest Trees.

A large number of fine trees meet with an early death, on account of rotting in the center. This rotting is brought about in all cases, by stumps of broken branches. When these rot, the decay soon permeates the whole trunk. No stump should ever be left on a tree, whether the branch be cut off with a saw or broken off by the wind. It should be taken away clean to the trunk, and the scar painted over so as prevent decay, until the wound is wholly covered by the new growth of wood and bark. When trees commence to fail, many persons imagine it is owing to some trouble at the roots, and if the tree is much valued, the earth around the roots may be dug up and disturbed. It is a good practice to apply fertilizing material, even to an old tree, as an abundance of food helps it to sustain its vigor; but all this is of no avail as long as dead stumps are left to decay the center of the tree. It is chiefly on this account that so much injury results from cutting back large branches. In a large number of cases the stump dies, with the results already enumerated.—*Meehans' Monthly*.



The above fragment of a monument in an Italian cemetery, displays to some extent to what degree sculptural art is carried in the higher class of cemetery monuments in sunny Italy.





# EPITAPHS

Hang her an epitaph upon  
her tomb.  
—Shakespeare.

There are some quaint epitaphs in Evergreen Cemetery, Brooklyn, many of the remains and old stones coming from the churchyards:

Elizabeth R. Johnson died in the ninety-fourth year of her age. On the stone at the head of the grave this appears: "Having a desire to depart and be with Christ, which is far better."

On many of the old stones this epitaph can be seen:

Affliction sore long time I bore,  
Physicians were in vain,  
Till death did seize, and God did please  
To ease me of my pain.

The following is just discernible on a stone under a spreading elm:

If modest merit joined to hearts sincere,  
May claim the parting tribute of a tear,  
That tear may now for those be freely shed,  
Who here lie sleeping with the silent dead.

In Cypress Hills Cemetery, Brooklyn, some quaint old epitaphs can also be found:

This tender admonition to his widow appears on the tombstone of John H. Hollsberg, who died in 1861.

Weep not for me my widow dear;  
I am not dead, but sleeping here.  
My debt is paid, my grave you see,  
Prepare yourself to follow me.

On a little stone, which is nearly hidden from view this quaint epitaph can be seen:

When you our friends are passing by,  
And this informs you where we lie,  
Remember you ere long must have,  
Like us, a mansion in the grave.

On the tomb of James Hampson is this inscription:

"Peace on earth, with my family and relatives I had none; in death and the grave I wish to sleep alone."

The following is found at Newport, R. I., and stands for three things, a daughter, a son and an arm, the inscription being as follows:

Wait, daughter of  
William and Desire  
Fripp, died Ap. 24,  
1780, aged 10 mo  
10 days.  
amputated Feby.

Also William, their  
son, died Mch. 17,  
1784, aged 22 mos.  
Also  
his wife's arm  
20, 1786.

## The Cemetery Superintendent's Convention.

The following is the program of the ninth annual convention of the Association of American Cemetery Superintendents, to be held in Richmond, Va., September 18, 19, and 20, 1895:

9 A. M., WEDNESDAY, SEPT. 18.

Meeting called to order. Roll call.  
Address of welcome.  
Receiving new members.  
Announcements of Executive Committee.  
President's Address.  
Report of Secretary and Treasurer.  
Communications.

1st Paper. Cemeteries on the Western Plains and their Ornamentation.—J. Y. Craig.

2d. Paper. Drainage.—A. W. Blain.

3d. Paper. Irrigation in Cemeteries.—F. von Holdt.

AFTERNOON.

Drive in the Eastern suburbs, including visits to Oakwood Cemetery, old St. John Church, where Patrick Henry made his famous speech; Chimborazo Park; Libby Hill Park, and other places of interest.

EVENING, 8 P. M.

Appointment of Committees.

4th. Paper. Derivative Benefit of our Association.—G. H. Scott.

5th. Paper. Our Experience with Road Drainage.—J. C. Cline.

Informal discussion of questions by members.

9 A. M., THURSDAY, SEPT. 19.

Roll Call.

6th. Paper. Greenhouses in Cemeteries.—J. G. Barker.

7th. Paper. Cemetery Boundaries.—T. McCarthy.

8th. Paper. Obstacles to be Overcome in Starting a new Cemetery on the Modern Plan.—J. Gunn.

Questions by members for discussion.

AFTERNOON, 2 P. M.

9th. Paper. Our Native Trees and Shrubs.—J. H. Shepard.

10th. Paper. Grading.—Frank Eurich.

11th. Paper. Suggestion for the Benefit of our Association.—Chas. Nichols.

12th. Paper. Economy in Laying Out New Grounds.—Geo. E. Rhedemeyer.

Discussion of papers and questions by members.

EVENING, 8 P. M.

Music and Entertainment.

9 A. M., FRIDAY, SEPT. 20.

Report of Committees, and election of officers.

Unfinished business.

New business.

Adjournment.

AFTERNOON.

Drive in Western suburbs; visit to Hollywood Cemetery, Corcoran and Monroe Parks, Lee's Monument, Soldiers' Home, Barton Height and other places of interest.

The "Murphy" has been selected as both the place of meeting and abode, and special rates have been secured: American plan, \$2.00 to \$3.00 per day; European plan, 75 cents to \$1.50 per day, the latter with bath and toilet. The "Murphy" is located at corner of Broad and 8th streets, easily reached by cars, and within two blocks of the City Hall and State Capitol.



▷ PARK NOTES. ◁

The city council committee of Huntington, W. Va., has selected a site of 60 acres for a public park in that city.

\* \* \*

The stockholders of the fair grounds at Grand Rapids, Mich., have agreed to convert them into a public park. The property consists of about twenty-five acres of very nicely located land in the residence portion of the city.

\* \* \*

A branch of the Town Improvement Association of Amesbury, Mass., desiring to improve a certain spot, is preparing for a series of athletic games to be held on the fair grounds, the charges for admission to be devoted to the cause.

\* \* \*

The country commissioners of Hennepin Co., Minn., have received a proposition for the donation of some 260 acres of land, covered with natural forest growth, situated on a lake a few miles southwest of Lake Minnetonka, for park purposes, by a Mr. Dexter of St. Louis.

\* \* \*

An association has been incorporated in Berlin, Wis., under the title of the Advancement Association of the City of Berlin, with the purpose of acquiring by gift or purchase real or personal property in that city for public parks and other purposes for the improvement of Berlin.

\* \* \*

The project of establishing a state park in northern Wisconsin, with Star lake as a central gem in the forest reserve, is warmly urged by a number of influential men. It is a place of great natural beauty, and it will preserve a portion of the great North woods from the general destruction incident to the march of civilization.

\* \* \*

In the precincts of the cathedral of Hidesheim there is a rose tree said to be more than 1,000 years old. The tree for some years past has given signs of decay, and in order to preserve it, several gardeners and botanists were called in, who have not only succeeded in keeping the tree alive, but have put it in a flourishing condition. They expect soon to see it bearing a rich crop of roses.

\* \* \*

Governor Rich, of Michigan, has received from Secretary of War Lamont the documents formally transferring to the state of Michigan the military reservation, buildings and lands of the national park on Mackinac Island. By the terms of the transfer the property is to be used for a state park and for no other purpose, and whenever the state ceases to use it for such purpose it will revert to the United States.

\* \* \*

Mr. F. L. Olmsted objects to the crowding of Prospect Park, Brooklyn, with statues and monuments, which in time would detract from the natural beauties of the place. He says: "Appropriate places for all the monuments that will be erected can be found in the small parks and public squares, or open spaces here and there in the city, where they would show to advantage and not interfere with the view of broad landscapes."

\* \* \*

Vermilye & Co., New York bankers, have been awarded \$1,000,000, of the two and a half millions of bonds authorized to be issued for the prosecution of the Essex Co., N. J., park scheme. This will give the commissioners all the necessary funds needed for the present and a stipulation of the agreement of sale is that no more bonds be issued the balance of the year. The price paid is \$100.77 and accrued interest.

A good suggestion, and one based on long experience, is that of John Dick, veteran florist and gardener of Philadelphia. It is that the city should remove all the bodies from the inter-urban cemeteries, to the upper end of Fairmount Park, and thus acquire ground for park and pleasure purposes, and in case cited, make use of land to some extent inaccessible and unemployed. This is a solution of a problem which in a few instances is being carefully carried out.

\* \* \*

Methuen, Mass., will soon come into possession of a valuable tract of land, the gift of Mr. E. W. Searles, which is offered to the town for a public park. The lot is a large one. Mr. Searles, who is seeking to improve the surroundings of his mansion, desires the town to widen Lawrence street in front of the High School, in consideration of which he will give a second lot of and for the enlargement of the school grounds. His gifts to the town are said to be the first steps in a plan of public improvements to be carried out on an extensive scale.

\* \* \*

A conference was recently held at Alexandria Bay, New York, between the New York senate game committee and the Canadian Minister of Marine and Fisheries. The conference was held with the object, if possible, of making arrangements for an international park somewhere among the Thousand Islands, between Kingston and Prescott on the Canadian side and Cape Vincent and Ogdensburg on the American side. Of all the ideal places for a park, it will be conceded that the Thousand Islands of the St. Lawrence is beyond question.

\* \* \*

The curious conceits in the way of plant pictures and oddities in ornamental gardening, for which Washington Park, Chicago, has been noted in the past are not in evidence this year, and will, of course, be missed by many admirers of this department of gardening. Douglas and Garfield parks on the West side, have two noticeable examples; the former a mound forty feet in diameter by twelve feet high, divided into four parts containing symbols in plants of Zoology, Geology, Astronomy and Botany. Garfield Park has a representation of old Fort Dearborn, of large dimensions.

\* \* \*

An act was passed by the last legislature of Indiana to establish a Department of Public Parks in cities of over 100,000 inhabitants according to the last preceding United States census, and creating a board of Park Commissioners. The act provides a board of five members to be appointed by the Mayor, who shall serve without compensation, but whose expenses and clerk hire shall be supplied. It further prescribes the duties of said board, its powers, features under its control and financial conditions. It also defines certain relations between the city authorities and the board, and the methods to be pursued in acquiring property and assessing for payments for same.

\* \* \*

The site for the Botanic Garden in Bronx Park, New York, has been selected by Calvert Vaux, the landscape architect of the Park Commission, assisted by Mr. Samuel Parsons Jr., Park Superintendent. The site takes in the most beautiful sections of Bronx Park, including the noted Hemlock Grove, which by resolution is absolutely preserved from disturbance in any way whatever, unless in the presence of a representative of the Park Board. Special attention was paid to including Hemlock Grove in the new Garden, because it is the most beautiful natural spot in the entire park system. At the same time, to guard against any possible injury to the grove in the future, the above restriction was made to guarantee its preservation. The site combines such varied kinds of scenery as will make it especially desirable for the purposes to which it is to be devoted. Two hundred and fifty acres is the area surveyed.



# CEMETERY NOTES.

The most costly tomb in existence is said to be that which was erected to the memory of Mohammed. The diamonds and rubies used in the decorations are worth \$10,000,000.

\* \* \*

"I don't say that a man ought not to smoke a cigar in a cemetery; but he ought to hide the stump.

"Peanut shells and banana peels are an abomination on a well kept lawn," says J. S. Goodge, superintendent Oak Hill Cemetery, Evansville, Ind.

\* \* \*

The old custom of having the sexton at the burial drop a part of a shovel full of ground upon the coffin as the minister repeats "ashes to ashes and dust to dust," is too antiquated and revolting, and we hope to see it discontinued. It certainly can give no real lesson and can be anything but agreeable to the mourners and their friends, to hear a shovel full of dirt rattling down as a last memory of the departed.— Cedar Falls Gazette.

\* \* \*

The selectmen of the town of Palmer, Mass., have given to the trustees of the Palmer Cemetery Association, control of the Depot village cemetery for this year. A superintendent has been chosen and rules and regulations laid down for the improvement and care of the place, which will result in a great change if carried out, which it is the intention to do. Much good would result if similar action were taken in other places having cemeteries controlled by the authorities.

\* \* \*

Mr. George Scott, of Boston, has placed in the hands of the trustees of Edgewood cemetery, Nashua, N. H., funds for the perpetual care of his lot in that cemetery. At the same time he also donated a generous sum for the perpetual care of the grave of Benjamin Abbott, a drummer boy in the Revolution, who lies buried there. Abbott was the drummer boy at the execution of Major Andre. Mr. Scott was no relation of Abbotts, but gave the money from purely patriotic sentiment upon learning of the burial of a Revolutionary hero there, a worthy example which should lead to similar donations for like purposes.

\* \* \*

Percy Alden, head of Mansfield House University Settlement, London, relates some pitiable experiences in his relations with the poor. The following displays some conditions of family life: "On one occasion I was calling upon one poor mother, who was laboring under the burden of bringing up twelve lively youngsters who had come into the world in quick succession year after year. She was complaining bitterly, and was envying her neighbor across the street, all of whose children had early succumbed to the ravages of poverty and ill treatment. 'I tell you what it is, Mr. Alden,' said she, grimly, 'I ain't never had no graveyard luck like her.'

\* \* \*

To prevent as far as possible the duplication of monuments, and so protect existing interests, and the appearance of the cemetery, Graceland Cemetery, Chicago, requires both the lot owners and contractors to sign the following statement which is attached to the design submitted to the superintendent:

"So far as we know the monument which is shown by the accompanying design is not a duplicate of any monument now in Graceland cemetery.

..... Lot-owner.  
..... Contractor."

\* \* \*

Mountain Grove Cemetery, Bridgeport, Conn., is undergoing extensive improvements under a proposed outlay of \$35,000

In the past, nature has been allowed to run riot with the result that much clearing up has been required. The North avenue stone archway which was built originally from the receipts of one of Jenny Lind's concerts over forty years ago, has been renovated. A new main entrance is to be constructed together with a chapel, for which the surroundings have been prepared. Mountain Grove cemetery is the third rural burial ground in the country, and in recent times has received some very fine monuments. It contains eighty acres, and 10,000 bodies have been buried within its borders.

\* \* \*

Under the head of "Funerals" in the Rules and Regulations governing the cemetery of "The Holy Name," Jersey City, N.J., recently issued, appears the following, which speaks for itself: "Christian hope and tender resignation ought to prevail at the burial of the dead. Christian thought on such an occasion should instinctively dwell on the immortal soul, not on the corruptible body. Hence the simpler the burial of the dead, the more Christian, and the more edifying it will be. The pomp and display so common at funerals spring from mistaken respect for the dead, although intended as signs of honor and affection; hence the long line of carriages and the profuse display of flowers. Profound sorrow avoids show. Simplicity in funeral arrangements is therefore to be recommended. Let the casket be modest, the carriages few, and let flowers be omitted, except in the burial of children."

\* \* \*

The perpetual care fund of Woodlawn Cemetery, Winona, Minn., now amounts to \$11,816.10, having been increased the past year by \$3,423.05. The number of burials for the year were 161, giving a total number of interments of 4280. The increase in the perpetual care fund of \$3,423.05 during the year, while receipts from the sale of lots were only some \$1,000. is due to a number of lot owners, whose lots were purchased before the new form of deed was adopted, having made "permanent care" contracts by which, in consideration of the payment of ten cents per square foot, the association agrees to perpetually care for the lots without further cost to the owners. The small returns from sale of lots is due to two causes. First, although the population has increased very greatly the number of interments in Woodlawn has not materially increased. Second: when the cemetery was first started a number of citizens were induced to buy lots at the very low price of fifteen cents per square foot in order to raise funds to open the cemetery. And a large number of lots were sold which were not required for immediate use, and which were never used by the original purchasers. These comprise many of the most desirable lots in the cemetery.

\* \* \*

The following curious notes on Chinese funeral and burial customs have been gathered by the Chicago Daily News:

China is called one vast cemetery. The face of the whole country is dotted with grass-covered hummocks—in the rice fields, open lots and wayside inclosures. No farm is so small that it cannot afford one, and no hill too high. They vary in size and shape. Near Shanghai they are shapeless mounds of earth 6 by 3 and 3 feet high. The coffins had been put on the ground and covered with dirt.

Near Soochow the graves are brick affairs, round topped and square at the ends. Some have door-ways, and look like bake ovens.

The farmers bury their dead in their rice or cotton fields or among their mulberry trees, and the poor buy or lease ground from their neighbors. It is claimed that at a change of dynasty all graves are razed and the ground pre-empted for the living.

Travelers see scores of tombs worn by the elements so as to show the coffin ends or skulls; great earthen jars containing re-interred bones; bare coffins set out in rice fields because the mourners were too poor to bury them and tens of thousands of coffins covered over merely with thatched straw.

The grand tombs of the mandarins take up half a mile of land with their arches, steps and carvings,



Several cemeteries in Maine are claiming the following: Five small stones in one lot, all alike except for the inscriptions, read something like this: Anne, first wife of John Brown; Mary, second wife of John Brown; Jane, third wife of John Brown; Clara, fourth wife of John Brown; John Brown, "At rest, at last."

## RULES AND REGULATIONS.

Every cemetery should be governed by certain rules and regulations, which should be printed in pamphlet form for distribution among lot owners. While this has been done in most of the large cemeteries, where the rules are very much alike, we will, for the benefit of the smaller cemeteries, publish in this department such rules as commend themselves for general adoption. Contributions are solicited.

Many amendments have been made to the Rules and Regulations of Oakland Cemetery, St. Paul, Minn., since April 3, 1889, which have been collated and added to their pamphlet.

A charge of two dollars is now made for the transfer of any lot.

Proprietors of any lots may erect any proper stone, monument or structure, such as has been approved and is in use in other cemeteries; but all bodies must be buried at least three feet below the surface, and plans for any structure designed to contain bodies of the dead must be submitted to the Board of Trustees for approval.

Where a lot is owned by two parties, and both desire to erect a monument, it is recommended that they unite in erecting a joint memorial. Monuments shall be set on the central longitudinal line of the lot except on lots of irregular shape, when superintendent shall determine. Any memorial structure exceeding two feet in height shall be considered a monument.

In addition to one monument on a lot, only one marker to each grave lot will be permitted, which shall not exceed four inches in height above the surface, and shall extend not less than eight inches below.

No monument will be allowed in the single grave sections, except headstones not exceeding eighteen inches in height or more than two feet in width, including base. On the two-grave lots, monuments shall not exceed eighteen inches by thirty-six inches in size of base nor three feet in height. On the three-grave lots monuments shall not exceed eighteen inches by forty-two inches in size of base nor four feet in height.

Corner posts shall be of stone, metal or terra cotta, not exceeding eight inches square and not less than one foot in length. The upper surface shall be set level with the surface of the earth.

Permits may be issued to lot-owners or members of their families to ride bicycles in the cemetery at a speed not exceeding five miles an hour.

## Correspondence.

LYNN, MASS.

*Editor Park and Cemetery:*

DEAR SIR:—As our annual convention will take place in a few weeks, at Richmond, let me impress it on the minds of the members to be present. Let us all make an effort to increase our membership, and let us all strive to make our next the best yet. To be sure there is some pleasure in meeting at our conventions, but from a business standpoint no superintendent can afford to absent himself.

I am well aware that men exist that think they know it all; but there are always exceptions to the rule. The most of us do not know everything pertaining to cemeteries, but are anxious to learn, and that is just the object of our Association. Exchanging ideas, visiting other cemeteries, and studying, are the ways to perfect ourselves in our calling.

The cemeteries of to-day are much admired for their neat and tidy appearance, and what makes them so, but the taste of those who have them in charge. The more we learn, and the more our minds are broadened, the better our grounds will look.

Let us then all try and be present and endeavor to reach the place where there is always plenty of room, "on top."

WILLIAM STONE.

\* \* \*

CAMDEN, N. J.

*Editor Park and Cemetery:*

DEAR SIR:—In reply to question of "Open Cemeteries on Sunday," I will say: while I think every cemetery on good paying basis should enforce this rule, yet I question its success for a new one hardly able to support itself. My experience has been a good one in regard to this, especially in a modern cemetery, where so many restrictions govern the lot-owner. Yet they do not look at it in the same light; some think when they pay for a lot they have the right to do with it as they please. Upon a second thought they do not realize the advantage of the new method as being less expensive, and one talks to another condemning the idea and naturally go elsewhere. A modern cemetery of to-day, cannot bar the public from visiting the cemetery; that is, if they wish to succeed. You must make every possible effort to induce the public to visit your cemetery and show them what you are doing. We know a great many people cannot spare the time to visit such places during the week, and it stands to reason they should be allowed to investigate Sundays. Our best sales resulted from allowing everybody to enter with strict observance of Rules, and hope some day to be able to feel more independent.

R. E. G.

\* \* \*

July 17, 1895.

*Editor Park and Cemetery:*

DEAR SIR:—Hardly a week passes but what we hear of something new in horticultural work. The only thing which seems to be slow in coming forth is a "Dwarf Lawn Grass Seed," something which does not require constant cutting.

Imagine this! Wouldn't it be a help to us? Why not get some of our wideawake seedsmen to assist in this. We want something to curtail the expense of extensive lawns.

THE MODERN CEMETERY.

\* \* \*

FORT PLAIN, N. Y., July 16, 1895.

*Editor Park and Cemetery:*

DEAR SIR:—The opinion has been very often expressed by people who should know, that our cemetery is one of the most attractive for its size in the country. It is beautifully located, and the entire cemetery is under perpetual care, which makes it possible to keep it in good condition throughout.

WILL C. RAPP, Superintendent.

## Association of American Cemetery Superintendents.

O. C. SIMONDS, "Graceland," Chicago, President.

G. W. REESY, "Harmony Grove," Salem, Mass., Vice-President.

F. EURICH, Woodlawn, Toledo, O., Secretary and Treasurer

The Ninth Annual Convention will be held at Richmond, Va., September 18, 19, and 20, 1895. See program in another column of this issue.



**Extracts.**

The works of a person who builds begin immediately to decay; while those of him who plants begin directly to improve.

*William Shenstone, 1764.*

The modern garden cemetery like the modern religious impulse seeks to assuage the cheerlessness and sternness of life and to substitute that free and gracious charity which was the mission of One who came to rob death of its hideousness.—*American Gardening.*

What seems to me to be desirable is that our cemeteries may become Arboretums, and instead of a large number of any one kind of tree or shrub, to have a variety. It certainly does not add to the beauty of any cemetery for any one species to so greatly predominate as to give the visitor an unpleasant sameness. A careful selection containing but one or two species of each distinct kind, judiciously distributed through the grounds will produce a fine effect, at the same time will be a test as to the nature and hardiness of a large number.

*Wm. Salway.*

It may be said that the cultivation of flowers on cemetery lots helps to bridge over the harsh bereavement and sorrow following death, and no doubt in some few cases this may be true; yet in the majority it is but a matter of fashion. But where pleasing variety in unity of natural landscape effects is wanted, the personal wishes of a few cannot be regarded; all interested must be taught and guided by the one controlling sentiment and object in view, to make the whole in strict harmony with, and in subordination to nature. As an eminent writer says: We must try and combine cheerfulness of aspect, luxuriance of growth, shade, solitude and repose in such a manner as to follow and imitate nature, for disgust and ennui will soon be excited where constraint and art are betrayed."

*F. Eurich.*

**Publishers' Department.**

**NOTICE TO SUBSCRIBERS.** If this notice is marked with a blue pencil it indicates that your subscription to PARK AND CEMETERY has expired and a renewal of same is solicited.

Park Commissioners and Cemetery trustees are requested to send us copies of their reports.

Photographs and descriptive sketches of interesting features in parks and cemeteries are solicited from our readers.

PARK AND CEMETERY wants the names of every park and cemetery official or employee who would be likely to be interested in this paper. To the many subscribers who have sent in such lists of names, we return our thanks. There are many more that we should hear from.

Subscribers are again reminded that we want brief notes on any feature of park or cemetery work that will be of general interest. PARK AND CEMETERY is the only publication of its class and earnestly solicits the co-operation of subscribers in making it a help to all identified with such work.

The Third Annual Report of the Board of Park Commissioners of the City of Duluth, Minn., for the year 1894, is one of the handsomest pamphlets of the kind yet to hand. It contains 54 pages which include 15 full page illustrations taken from the various parks of that city. It is a great pity that the commissioners allowed the plates to be disfigured by the imprint of the printing house. This should never be allowed, and if an advertisement is necessary it would be better to sacrifice a space anywhere than on the engravings.

George L. Transue, Superintendent of Easton Cemetery, Easton, Pa., would be pleased to receive photographs or sketches of cemetery office buildings, waiting rooms, superintendent's residences, etc., His cemetery contemplates the erection of such buildings, and it is the intention of using rubble stone work for the exterior, and to provide them with all modern improvements.

Orlando T. Carpenter, Engineer, Kensico Cemetery, New York, visited the cemeteries of Buffalo, Cleveland, Chicago and Detroit recently. Kensico is a modern cemetery and its officials are active in keeping up with the times.

**RECEIVED.**

Regulations, Fair View Cemetery, New Britain, Conn., 1886.

Rules and Regulations governing the Cemetery of "The Holy Name," Jersey City, N. J., 1895.

Fourth Annual Report of the Trustees

of Public Reservations, Mass., 1894.

Articles of Association of Oakland Cemetery, St. Paul, Minn., with the revised By-laws, Rules and Regulations adopted A. D. 1889, with additions and amendments to July 3, 1895.

TOWN RECORDS and REPORTS of the Town officers of Brookline, Mass., for the year ending January 31, 1895, containing among other records a report of the Walnut Hill Cemetery.

**TESTIMONIALS.**

PARK AND CEMETERY is one of those publications that should be in the hands of every Park and Cemetery association and be read by every one who takes an interest in having beautiful burial or pleasure grounds.—Lafayette, Ind., *Leader-Editor Park and Cemetery*:—

Enclosed find \$1.00 for another year. I do not know where I invest a dollar with such good returns. I only wish it was semi-monthly at \$2.00. Wishing you every prosperity that an editor can hope to obtain. Wm. Stone, Supt. Pine Grove Cemetery, Lynn, Mass.

Hartford, Conn., July 16, 1895.  
*Editor Park and Cemetery*:—

Your excellent paper comes to hand regularly and is highly appreciated. You are giving us some grand numbers. I think the addition of the "Park" is of as much benefit to the Cemetery Superintendent as to the Park official in these days of cemetery landscaping. With best wishes for your success. *N. C. Wilder, Spring Grove Cemetery Association, Hartford, Conn.*

*Editor Park and Cemetery*:—

You will please find money order for my subscription to PARK AND CEMETERY for another year. I find your publication of great use to me as teaching me how to control a cemetery, and its multifarious concerns aright. J. R. Ruel, President Rural Cemetery, St. John, N. B.

*Editor Park and Cemetery*:—

Please renew our subscription for the PARK AND CEMETERY for this year. We consider your paper a very valuable assistance to any one in charge of a cemetery. P. H. and F. M. Webster, Mngrs. of Oak Hill Cemetery Association, Bradford, Pa.

R. J. Haight:—I herewith enclose payment for subscription to PARK AND CEMETERY. I like the paper very much as there is a very great deal of information gained from it. R. W. Sutton, Supt. Green Hill Cemetery, Amsterdam, N. Y.

R. J. Haight:—Please find check for renewal of subscription to PARK AND CEMETERY. I am very much pleased with the paper, and wish you God speed in your chosen work. H. R. Chaffee, Bridgeport, Conn.



# PARK AND CEMETERY.

FORMERLY THE MODERN CEMETERY.

A Monthly Journal Devoted to Parks and Cemeteries.

R. J. HAIGHT, Publisher,  
334 Dearborn Street, CHICAGO.

Subscription \$1.00 a Year in Advance. Foreign Subscription \$1.25

VOL. V. CHICAGO, SEPTEMBER, 1895. No. 7.

## CONTENTS.

EDITORIAL.....	109
BOTANICAL GARDENS.....	110
*RUSTIC VASES AT LINCOLN PARK, CHICAGO.....	112
PRESERVE VALUABLE TREES.....	113
THE ONONDAGA COUNTY CEMETERY ASSOCIATION.....	113
*HILLSBORO CEMETERY, HILLSBORO, O.....	114
CEMETERIES AND CREMATION.....	114
THE CEMETERY SUPERINTENDENT'S NINTH ANNUAL CONVENTION—PRESIDENTS ADDRESS.....	116
*THE PARKS OF DULUTH, MINN.....	118
*THE SMITH MAUSOLEUM, CHARLESTON, S. C.....	120
NOTES ON THE RHODODENDRON.....	120
*GARDENING IN HARMONY GROVE CEMETERY, SA LEM, MASS.....	121
CEMETERY ACCOUNTING.—II.....	122
PARK NOTES.....	123
CEMETERY NOTES.....	124
CORRESPONDENCE—CREMATION.....	125
EXTRACTS—PUBLISHER'S DEPARTMENT.....	126

\*Illustrated.

THE ninth annual convention of the Association of American Cemetery Superintendents was held at Richmond, Va., on the 18, 19 and 20 of the month. It was expected that the location of the convention city would impose obstacles to a very strong attendance, which happily was not the case; but it militates against a comprehensive account of the proceedings, or publication of the important papers and discussions in this issue of PARK AND CEMETERY. As heretofore a full report will be published by the Secretary in due course, which will make another valuable addition to cemetery literature.

THE most important event of the month of September has probably been the dedication and other ceremonies attending the public opening of the Chickamauga National Park. The press generally has been teeming with descriptive matter concerning this great historical object lesson; and truly, the whole undertaking, with the liberality displayed in its thorough equipment for the object sought, is well worthy of being set forth in such a manner as that the people shall realize pos-

itively what a great work has been carried out for them. The occasion brought together representative men from all over the country, civil and military, and the spirit of the work animated all the speeches and exercises. The park includes some ten square miles of country, with a fine driving road twenty miles long, passing through battle ground its entire length. The government owns it in fee simple, as well as jurisdiction over the roads to battle fields and through them. The several great battles fought on the ground are illustrated through miles of lines marked by tablets and monuments, with actual batteries in place of patterns used in the battles. Twenty-five State Commissions, Union and Confederate, have been engaged for months on the work. Of the twenty-eight states which had troops on the fields, nine only have made appropriations, calling for 169 monuments, about 100 of which are on the ground. The amount thus far appropriated by the nine states is over \$350,000. Illinois has chosen to erect monuments of one design for all organizations, simply changing the inscriptions. By this it is believed the positions of Illinois troops as a whole can be more readily seen. Indiana uses Indiana limestone for its monuments; Tennessee, Tennessee marble, and it is probable as the states are represented in the park, this idea will be still more prevalent. The project is only fairly begun; and as it progresses to completion, its conception and realization will become more and more highly appreciated.

ELECTRICITY is becoming more and more intimately associated with human needs as the days go by. As a motive force its application is assuming universality, while in many other directions its wide range of usefulness is being brought under control through scientific research and the application of discoveries resulting therefrom. Since the motor has been used for the propulsion of street cars, more refined conditions have prevailed, and the innovation has been introduced, very satisfactorily too, of bringing into service electric funeral cars. The advantages of this departure are manifest; it is in the line of progress, and is supplanting the very objectionable features which have been so long endured in connection with the funeral hearse and its attendant details. It moreover contributes to economy in funerals and admits of changes, which, while not detracting from the conditions properly belonging to the occasion, go



far to meet questions now under serious discussion. We note however that the wonders of electricity have been brought into further use in funeral ceremonies, according to an eastern paper, wherein the phonograph acted as substitute for the clergyman in the funeral oration, a popular divine officiating through that instrument. This must be considered in the light of an experiment, and from many points of view of doubtful appropriateness. The substitution of the mechanical for human personality is a leap, the landing place of which is not yet apparent.

THE relations existing between the lot owners of a cemetery and its officials are frequently more or less strained over the enforcement of rules and regulations that appear at first sight arbitrary. Similar conditions often result from the enacting of new rules. This slight friction has been more apparent of late and is chiefly due to the changes necessarily involved in the adoption of modern ideas in relation to the management of cemeteries. The old, unbusinesslike, go-as-you-please, methods so long prevailing, and which resulted in untidy, ill-planned and carelessly governed grave yards, also resulted in a lack of discipline all round—lot owners and officials alike. The new order of things, beginning as was imperative with the officials, required a general overhauling of affairs and attention to long neglected laws and rules. Following this, when practical work was inaugurated, an enforcement of rules was absolutely necessary to secure desired results, which in certain cases developed more or less opposition to what was considered arbitrariness on the part of the management. As improvements proceed new laws are required which in the very nature of progress are necessarily definite and not of the dead-letter order. It must be assumed that the rules are adopted for the welfare of the lot owners, subserving their best interests as a whole; and that a wise management, knowing the penalty of lack of wisdom or integrity, will carefully consider the comfort of the lot owners as well as the interests of their property. All laws will then be enforced with forethought and consideration, and with lot owners properly educated in the requirements and necessities involved in the highest development of their property, will cheerfully accede to conditions heretofore unknown to them. The education of the lot owner is a prime necessity of the modern plan of cemetery management, and every means available to the officials should be immediately exercised to that end. It lies principally with officers to avoid the reproach of "arbitrariness", which should be a term obsolete in the cemetery lexicon.

#### Botanical Gardens.

The following is a revision by the author of an article, in the September issue of the *Popular Science News*, on a subject which is a pertinent one at present:

The initial and very important consideration in the botanic garden is the site. Several of the finest gardens of the Old World have been permanently injured by a lack of foresight and common garden sense in the choice or want of choice in this respect.

The sites should be chosen with reference chiefly to their accessibility and adaptability. They should be approachable by road, river and railway, and adaptable not only in aspect and soil, but also in their topography, to the economical and clear arrangement of the hardy and exotic collections, which means not only that two-thirds of their surface shall be absolutely free of interfering growths, but that their contour be such that the ensemble of planting and building form a harmonious and sequential whole. Mere picturesqueness of site is of minor consequence; it may often be commanded in conjunction, but should never be chosen at the expense of other and far more important essentials; picturesqueness, indeed, is often synonymous with intractability of surface, and endless watchfulness of resources. The art of the gardener can produce much of picturesqueness from growth alone, but in a garden for instruction sequential beauty and finished order is far more important.

Educational plantings may be of any size, but the ideal site would be in a regular or irregular parallelogram of 300, 400, or more acres of good land gently sloping upwards from the banks of a navigable river, with public roads existing on the sides or capable of construction, and with a railroad and fresh water stream in close proximity.

If the banks of such river were so wooded that a mere thinning of the trees would convert the woods into pleasure grounds, and the remoter uphill portion consisted of cleared fertile farm land, with a small river or creek across the upper boundary, it would probably prove to be as happy a conjunction as could be selected for economy and felicitous arrangement. If 150 or more acres could be left in woodland pleasure ground, it would afford a site not only for the free pleasure of the people, but for the naturalization of a host of native plants which cannot properly be admitted within the precincts of the dressed grounds containing the select and classified collections. The old Deer Forest at Kew has for fifty years been one of the most highly appreciated features, and encroachments upon it for arbor-etum purposes—necessitated by an entire want of system in the planting of the old garden—are often bitterly resented by writers in the *London Times*.



The beech trees are really decaying, however, and slowly but surely classified plantings are occupying the ground. They can never be properly in sequence, they can never be as grand in aspect as the old woods, which matured in freedom from the London gas and smoke, but imperfect though they may be, as a whole they are by far the richest in the world, and nothing short of a trained prescience can hope to approach and excel them. Perhaps as many as one-fifth of the flowering plants of the world are in cultivation at Kew. But although so much has been done in the effort towards classification, it does not greatly impress the visitor; *interfering growths obtrude themselves on every hand*, the mind of the tyro is confused and even discouraged, and he is apt to declare that botany as a system is a confusion that he at any rate can never hope to surmount by the aid of any existing garden. The herbarium and museums alone have proved manageable in their sequential arrangement at Kew. The *Genera Plantarum* of Bentham and Hooker is the accepted authority, and it is greatly to be hoped that all future arrangements and nomenclature will be brought into harmony the world over—as much for economy's sake as for intelligent understanding. In this country we have a real advantage in starting so late, for we benefit at once if we will by the great systematic labors of Jussieu, De Candolle, and Bentham and Hooker. Perhaps in one or two respects the system of groups adopted by De Candolle were more agreeable to place on the ground and retain in the mind than those of the later compilation; this is more especially true in the *Monochlamydeæ*, one of the groups of which is unwieldy, and on broken ground often necessitates tribal grouping, and the same may be said of the *Polypetalous Rosales*. As a rule, however, the only possible garden group at once comprehensive and capable of harmonious disposition is the cohort or alliance of orders. Of these there are forty-two which are adaptable to garden purposes, arranged as follows:

BENTHAM & HOOKER'S GROUPS OF THE  
GENERA PLANTARUM.

DICOTYLEDONOUS POLYPETALOUS EXOGENS.

- |     |                 |   |                      |
|-----|-----------------|---|----------------------|
| 1   | Ranales,        | } | <i>Thalamifloræ.</i> |
| 2   | Parietales,     |   |                      |
| 3   | Polygalales,    |   |                      |
| 4   | Caryophyllales, |   |                      |
| 5   | Guttiferales,   |   |                      |
| 6   | Malvales.       |   |                      |
| 7   | Geraniales,     | } | <i>Discifloræ.</i>   |
| 8   | Olacales,       |   |                      |
| 9   | Celastrales,    |   |                      |
| 10  | Sapindales,     |   |                      |
| 10a | Anomale.        |   |                      |

- |    |                |   |                     |
|----|----------------|---|---------------------|
| 11 | Rosales,       | } | <i>Calycifloræ.</i> |
| 12 | Myrtales,      |   |                     |
| 13 | Passiflorales, |   |                     |
| 14 | Ficoidales,    |   |                     |
| 15 | Umbellales.    |   |                     |

MONOPETALOUS EXOGENS.

- |     |               |   |                      |
|-----|---------------|---|----------------------|
| 16  | Rubiales,     | } | <i>Infcræ.</i>       |
| 17  | Asterales,    |   |                      |
| 18  | Campanales.   |   |                      |
| 19  | Ericales,     | } | <i>Heteromeiæ.</i>   |
| 20  | Primulales,   |   |                      |
| 21  | Ebenales.     |   |                      |
| 22  | Gentianales,  | } | <i>Bicarpellatæ.</i> |
| 23  | Polemoniales, |   |                      |
| 24  | Personales,   |   |                      |
| 25  | Lamiales,     |   |                      |
| 25a | Anomale.      |   |                      |

APETALOUS EXOGENS.

- |    |                 |                          |
|----|-----------------|--------------------------|
| 26 | Chenopodiales.— | <i>Curcembrycæ.</i>      |
| 27 | Podostemales.—  | <i>Multiovulatæ aq.</i>  |
| 28 | Asarales.—      | <i>Multiovulatæ ter.</i> |
| 29 | Piperales.—     | <i>Micrembrycæ.</i>      |
| 30 | Daphnales.      |                          |
| 31 | Santalales.—    | <i>Achlamydosporcæ.</i>  |
| 32 | Quernales.—     | <i>Uniscxualc.</i>       |
| 33 | Salicales.—     | <i>Anomale.</i>          |

GYMNOSPERMOUS EXOGENS.

- |     |              |
|-----|--------------|
| 34  | Coniferales, |
| 34a | Abietinæ,    |
| 34b | Cupressinæ,  |
| 34c | Taxinæ.      |

MONOCOTYLEDONOUS ENDOGENS.

- |    |               |                     |
|----|---------------|---------------------|
| 35 | Orchidales.—  | <i>Microspermæ.</i> |
| 36 | Narcissales.— | <i>Epigynæ.</i>     |
| 37 | Liliales.—    | <i>Coronariæ.</i>   |
| 38 | Palmales.—    | <i>Calyciuæ.</i>    |
| 39 | Arales.—      | <i>Nudifloræ.</i>   |
| 40 | Potomales.—   | <i>Apocarpæ.</i>    |
| 41 | Glumales.     |                     |

ACOTYLEDONOUS ACROGENS.

- |    |            |
|----|------------|
| 42 | Filicales. |
|----|------------|

*James MacPherson.*

Flowers seem intended for the solace of ordinary humanity; children love them; quiet, tender, contented ordinary people love them as they grow; luxurious and disorderly people rejoice in them gathered. They are the cottager's treasure; and in the crowded town, mark, as with a little broken fragment of rainbow, the windows of the workers in whose heart rests the covenant of peace.—*John Ruskin.*



**Rustic Vases at Lincoln Park, Chicago.**

Rustic vases similar to the one shown in the accompanying illustration have long been a feature of the summer decorations in Lincoln Park. A line of them alternating with trees, marks one side of the parallelogram south of the handsome new Palm House where the display of summer bedding is made. This line borders the canal that divides the flowers from the Zoological garden.

Vases of the same kind are also used this year on each side of the Mall, a long avenue in the southern part of the Park. Heretofore, beds of flowers have been used in the spaces between the trees that outline this broad walk, but the throngs that crowd that part of the Park on the nights when the electric fountain plays, have in former years had no respect for flower beds. So it was found necessary to replace them with something big enough to obstruct the passage of the people, and the vases serve the purpose well—being large enough to protect themselves. Then, too, they are decorative, when, as they always are in Lincoln Park, overflowing with vines and flowers.

The vases are all made by the design shown in the cut and are simple in construction although ornamental and durable. A cedar post six feet long is set three feet in the ground and on it is securely fastened an octagonal vase one foot in depth, thirty eight inches in diameter at the top and thirty four inches at the bottom. It is made of three quarter inch planks covered on the outside with Hemlock bark. Holes for drainage are bored, one in each section of the eight pieces composing the bottom, and the structure is strengthened by cross pieces screwed to the bottom.

In the center of each vase is an upright one foot high with a horizontal cross on top. On this cross is set another vase made exactly like the lower one but smaller, six sided in shape and only twenty inches in diameter at the top and seventeen inches at the bottom. The small vase is twelve inches deep, the same as the lower one, so that the top of the upper vase is five feet above the ground.

Some branches are used around the cedar post to add to the rustic appearance as well as to help support the lower vase, all being fastened together securely. The vases are very strong and are good for five years' use. The upper vases are taken inside in winter, but the lower ones are left in position the soil being removed when the plants are taken out in the fall.

In spring the vases are filled with good soil to which is added bone dust and thoroughly decayed manure. The plants used are well grown, flourishing pot plants so well supplied with roots that they are transplanted without checking their

growth. In the middle of the top vases flowering geraniums are used, semi-double varieties being best, and only good reliable bloomers being chosen—such as La Favorite, white; Mad Bruante, red; Emil de Girardin, pink; President Leon Simon, scarlet. Good single flowered ones such as Mrs. G. M. Garr, white; Rev. Watkins, scarlet; Gettysburg, crimson and Mrs. E. G. Hill, salmon, are also used to some extent. The upright, stocky Geraniums are surrounded by Petunias and Verbenas, while around the edge Ivy Geraniums, Lobelia Paxtoniana and double Nasturtiums are planted.

Good sized Geranium plants are used for the inside row in the lower vases, so that they will stand



A RUSTIC VASE IN LINCOLN PARK, CHICAGO.

up well around the sides of the upper vase, and with them are interspersed plants of the pretty yellow Daisy, Queen of Belgium, also of Fever few, Petunias and the odd but bright little annual Calceolaria that is raised from seed each year. Outside of these are placed such drooping and trailing plants as plain and variegated Vincas, Lobbs Nasturtiums, Lobelias, Verbenas, Maurandia Barclayana, Lophospermum scandens and Pylogene sua-vis or Musk vine, that charming member of the cucumber family that thrives so well in the sunniest exposure, weaving a thick covering of its glossy leaves, and dainty, but inconspicuous flowers. In rich soil its growth is very rapid. In a short time the thrifty plants used in the vases make such good



growth in the rich soil supplied, that the upper receptacles are quite hidden and each vase becomes an overflowing fountain of flowers and vines that increases in beauty to the end of the season.

*Fanny Copley Seavey.*

#### **Preserve Valuable Trees.**

Recently I visited a western city, having a population of seven or eight thousand people, for the purpose of making a design for the improvement of the home grounds of one of its citizens. The lot in question was bounded by streets on the north, east and south sides. The house faced the south street and the barn was placed near the north street, as was also the barn on the adjoining lot. The latter street was one hundred feet wide and the central fifty feet was being graded down several feet, leaving a high bank on each side, so that there would be no entrance to the lot from this direction. Along the south side of this street, about seven feet from the lot line, were a number of burr oaks and hickory trees of exceptional vigor and perfection. In talking with the assistant city engineer, who happened to be inspecting the work of grading the street, I suggested that the sidewalk be placed a few feet north of the trees and that the ground slope from the sidewalk down to the street, leaving the surface near the trees unchanged. There was no objection to this arrangement excepting that the city council passed an ordinance requiring sidewalks to be placed four feet from lot lines. This would take out all the trees on this street and also a fine large elm and two hickories on the east side of the lot. The engineer thought the removal of the trees would be necessary. The burr oaks in question had an abundance of large dark-green leaves. They made a beautiful background for the lot and an agreeable shade for those passing along the street. They were too large to move, and every rational consideration demanded their preservation. I know men who would be willing to give from one to two hundred dollars a piece for trees as good as the ones which the city official would destroy without a thought of doing injury. A slight deviation of the sidewalk would make no difference in the time required to walk over it. The planting of the slope with some shrubs, and the preservation of the trees, would make a beautiful effect along this street and would help hide the barns.

I mention the above facts to show how thoughtless many people are in regard to trees, and to call attention to one of the chief difficulties one has to contend with in his efforts to make beautiful streets and beautiful grounds. The ordinary city engineer is a good deal like a machine which must always do its work in a prescribed way. He does not look at

anything from an artistic point of view. To him, a piece of moulding cut out by a shaper is handsomer than a bit of Swiss carving. The City Council or the Board of Public Works may help to deface the city, but ordinances affecting public improvements are generally suggested or have to be approved by the city engineer.

Public streets are features of a city which everyone must use. They may have variety and beauty, or they may be commonplace and ugly. They may entertain, instruct and refresh, or they may annoy and oppress those who use them. One or two lectures on the artistic treatment of the borders of public highways, would be a valuable addition to a college course in civil engineering.

*O. C. Simonds.*

#### **The Onondaga County, (N. Y.) Cemetery Association.**

The Onondaga County Cemetery Association was organized, at Syracuse, N. Y., on August 29th., by the adoption of a constitution and the election of the following officers: George H. Wicks, President, Skaneateles; W. W. Newman, Secretary, South Onondaga; James Barnes, Treasurer, Syracuse; B. C. Chaffee, Syracuse, Jonathan Wyckoff, Onondaga, Henry Kinney, Otisco, N. O. Hoyt, Lafayette, William Rice, Elbridge, and C. W. Allis, Skaneateles, Vice-presidents; E. W. Mundy, Librarian, Syracuse. B. Chaffee, and L. S. Cleveland, were appointed a Legislative Committee.

Among the general business transacted was the passage of the following resolutions:

*Resolved*, That the thanks of the association and the people it represents are extended to the press of the country for kindly assistance in cemetery improvement; and we ask for its inestimable co-operation in the future.

*Resolved*, That we ask the Board of Supervisors to vote authority and means to enlarge the County Poor House Cemetery or select a new site on the county farm; and to provide cheap headmarks with names and dates for each future grave.

*Resolved*, That we request the Cornell Agricultural Experiment Station to publish one or more rural cemetery bulletins.

*Resolved*, That the recent change of the Skaneateles Cemetery from not one on record of a burial to over 2,300 now recorded, is an example worthy of all praise and is recommended to every cemetery.

*Resolved*, That we request the officials of Oakwood Cemetery to keep the thirty volumes of European Cemetery and Art Literature, given by Andrew D. White, on reference shelves in the Central Library of Syracuse for public use.

*Resolved*, That we request all cemeteries and citizens to aid in removing from abandoned farm burying grounds to respectable cemeteries the remains and monumental records of Revolutionary soldiers and all other pioneer settlers of Onondaga County.

A number of exhibits from different cities and cemeteries, in the way of photographs, models of appurtenances etc. were on view, as well as periodicals and other literature of value to cemetery interests,



**Hillsboro Cemetery, Hillsboro, O.**

The illustrations herewith, present views taken from two points, both looking west, in Hillsboro Cemetery, Hillsboro, O.



VIEW IN HILLSBORO CEMETERY.—Photo. by Phillip Weyrich.

This cemetery was organized under the state law of Ohio on May 7, 1859, at which time there were no charters as at present, and under the law 300 acres of land can be held for cemetery purposes free of taxation.

A few words on the history, and management of the cemetery may be of interest: Each lot holder is a member of the association, and has a voice in the selecting of its officers. There are seven trustees, one of whom is elected every year to serve seven years, a consequence of which is a tendency to harmonious working in that body. At the first election of officers, Mr. Benjamin Barrese was elected treasurer of the association, which office he held until his death on July 7, 1889. In certain particulars the histories of many of our smaller cemeteries are alike. It is said that the citizens of Hillsboro, were very much elated over the cemetery when first organized, and for a few years it was well cared for, but as new officers came into power and as there was no money in it, a long period of careless management supervened, until 1883, when a new board of trustees took hold and went to work with a will to make the place what it should be, a beautiful home for the departed.

Considerable improvements were carried out

last year, in the shape of new roads, new sections and a lakelet named in memory of the superintendent's daughter, Lake Augusta. This year other ponds have been added and some water gardening has been attempted.

The cemetery originally contained 31 acres but a few months ago, a further purchase of 81 acres, adjoining the cemetery on the north, was made. This plot is naturally beautiful, and can be readily improved. There is an abundance of natural trees, Oak, Ash, Elm, Beech, Hickory, Maple, Buckeye, Gum, Dog Wood, etc.

The cemetery is conducted as nearly as possible on the lawn plan, and the superintendent, Mr. W. A. Morrow says, that when mounds are made they are only raised the thickness of the sod. For the last ten years lots have been sold for cash, at 15 cents to 50 cents per square foot, and 40 per cent of the purchase money is placed in a perpetual care fund. A provision well worthy of emulation by other cemeteries. The question of perpetual care is one of the most important in cemetery management, and is at present receiving much attention.



VIEW IN HILLSBORO CEMETERY.—Photo. by Phillip Weyrich.

**Cemeteries and Cremation.**

It is claimed that the present is the Age of Progress, and the civilized world refers slightly to the efforts and doings of our forefathers. Yet in the matter of the disposal of our dead, we of the present generation, cling tenaciously to the oldest



fashions. Probably this may be attributed to the fact, that till Death strikes a family, little or no thought is given to the dreaded messenger; people avoid thinking of the matter. Death is inevitable, but in the opinions of most, had better not be thought of, with the consequence, that, when the time for separation arrives, attention is at once demanded. It cannot be postponed, grief prevents a calm consideration of the best method for the disposal of the remains; we hate to see the forms of our dear ones being taken away, though knowing it must be done, and that quickly. Consequently we adopt those methods which have been in vogue for ages. With costly preparations, we endeavor to keep the body so that it will resemble as nearly as possible that form which we remembered when living. Burial therefore seems the best, and indeed the only way of disposal.

From the dust of the earth man is made, and most surely to dust must he again return. Do what we will the process cannot be prevented; our puny efforts in this direction are fruitless. The most that can be done is simply to retard the process by embalming or mummyfying. Nature's ways are inscrutable and must be obeyed. Nothing can be more distressing to minds of the surviving, than the knowledge that the bodies of their dear ones, which are deposited in the earth, despite all efforts to the contrary, are slowly, but surely, becoming loathsome masses of corruption. The dear forms which are photographed in the mind's eye, will become so changed that if they could be brought to the light they would make the strongest turn away with disgust. And even after a lapse of years, the sight of our bones will create a shudder.

Knowing all this would it not be better to calmly and philosophically reason the matter, and as from dust we come, is it not most reasonable, after we are done with upon this sphere, to be returned to our natural element the dust, quickly as possible. And incineration is undoubtedly the quickest method.

Cremation in all civilized communities is largely upon the increase, and is likely to become more so, as people give their attention to the subject. One thing which retards progress, is the present great cost of incineration. But this will soon remedy itself, as the movement becomes more popular. The crematorium, and cemetery, should be combined, and doubtless will be in the near future. Their combination will allow smaller and more ornamental burial grounds being made in the midst of populous centres, without being a menace to the health of the living. In the larger cities the question of burial will soon be a matter of great expense and trouble. Large tracts of land, at con-

siderable distance from residential parts, will have to be dedicated for cemetery purposes. The cost of reaching these places, whether by railroad or otherwise is bound to be considerable. The very fact of conveyance alone, will far exceed the cost of cremation and depositing the ashes nearer by. Then as an economic fact the Crematorium and Cemetery should work together. All reforms come slowly and it is a difficult matter to get the public much out of the rut. When the combination is consummated, smaller family burial lots will answer, and can be used by succeeding generations, for the disposal of the ashes, either by interment and become a part of the soil or be scattered upon the grassy surface. That nature resumes itself is most true. All organic vegetable matter sooner or later becomes a part of the soil, and reappears in some other form. And it should be pleasant to know that the ashes of the bodies of our departed friends can assist to make the face of nature beautiful. When living most persons have a preference for some particular tree or plant. Then after incineration let our mortal ashes be so placed that they can quickly be absorbed by our favorites, and for a time at least live again. To the objectors for such means of disposal interment can be made in small graves. Columbariums will surely be built with niches for thousands of urns, and thus accommodate those who wish to preserve the ashes.

There is nothing repulsive in the modern method of cremation. The body is taken away by the attendants from the chapel or ante-room, and in a short time all that is left, contained in a small receiver is returned to the friends for final disposal. Crude oil and steam perform the work very expeditiously. And when incineration becomes more popular probably electricity will be brought into use and do the work still more rapidly.

*Bellott Lawson.*

A beautiful lawn is one of the grandest works of nature, let it be flat, undulating, or curved in outline, and the nearer we can copy nature the greater perfection we will attain. The predominating feature of all modern cemeteries of to-day is a lawn. When the body is laid at rest in our cemeteries, the friends return after a few hours or days as the case may be, there is nothing that seems to give them so much satisfaction as to find the grave, whether mounded or flat, also the lot covered with a soft green velvety lawn turf; even the beautiful flowers never seem to give so much satisfaction. They soon fade and are gone, whereas the green grass remains and grows more and more beautiful as the days go by, if only well cared for.—*N. C. Wilder.*



**The Cemetery Superintendents' Ninth Annual Convention.**

The ninth annual convention of the Association of American Cemetery Superintendents was held at the Hotel Murphy, Richmond, Va., Sept., 18, 19, 20th, and like the previous annual gatherings of the association was well attended by representative cemetery officials from different sections of the country. Fourteen states were represented by about fifty superintendents, many of them being accompanied by their wives.

At the opening session prayer was offered by Rev. Dr. George Cooper of the First Baptist Church. Mr. George L. Christian, on behalf of the city extended the most cordial welcome to the visitors. His address was made especially entertaining by reference to Richmond's important place in the history of our country. Mr. O. C. Simonds, of Chicago delivered his first address as president of the association; it is printed in full in another column and should receive the careful consideration of cemetery officials whether they are identified with this association or not. Mr. Simonds is an ardent advocate of cemetery reform and his excellent address contains much food for thought along such lines.

The annual report of the Secretary and Treasurer, Frank Eurich, showed the association to be in a flourishing financial condition with a membership of 136. Eight new members were enrolled at this meeting.

The papers read were as follows: Cemeteries on the Western Plains and their Ornamentation, J. Y. Craig, Omaha, Neb.; Irrigation in Cemeteries, by F. von Holdt, Denver, Col.; Our Experience with Road Drainage, by J. C. Cline, Dayton, O. This was one of the most practical papers read before the convention and was followed by a general discussion of the subject of drainage. Cementing all pipes used for mains and laterals was recommended, to keep out roots, dirt, etc. Green Houses in Cemeteries, by J. G. Barker, Boston, Mass. Mr. Barker submitted with his instructive paper abstracts from a large number of letters received from cemetery superintendents on the subject. He favors a judicious use of flowers and strongly recommends hardy herbaceous shrubs. Cemetery Boundaries, by T. McCarthy, Providence, R. I.; Obstacles to be Overcome in Starting a New Cemetery, by J. Gunn, Whitingsville, Mass.; Grading, by F. Eurich, Toledo, Ohio; Suggestions for the Benefit of our Association, by Chaales Nichols, Newark, N. J.; Rambling Thoughts, by Wm. T. Lockwood of Tarrytown-on-the-Hudson, N. Y.; Suggestions from a Monument Dealer, by J. H. Lloyd, Toledo, O. and Economy in Laying Out New Grounds, by Geo. E. Rhedemeyer, Camden, N. J.

In addition to the papers, foundations, windmills, taxation and several other subjects were profitably discussed. St. Louis, Mo., was chosen as place for the next meeting, at a time to be decided upon by

the executive committee. The officers consisting of O. C. Simonds, Chicago, Ill., president, George W. Creesy, Salem, Mass., vice-president, and Frank Eurich, Toledo, O., secretary and treasurer were reelected for the ensuing year. M. P. Brazill, St. Louis, Mo., R. P. Boyce, Genesee, Ill, and S. W. Rubee, Marshalltown, Ia., were appointed as executive committee. Resolutions of respect were adopted on the death of J. W. Lovering of Boston, Mass., and M. B. Ryan of Providence, R. I.

The program of entertainment arranged by Mr. John R. Hooper superintendent of Hollywood Cemetery, Richmond, included drives in the afternoons to parks, cemeteries and principal points of interest in and around the city of which more will be said in our next issue. A unique and thoroughly enjoyable entertainment on the second evening of the convention, furnished by local talent was the source of much merriment. Capt. Cunningham whose friends are legion, acted as master of ceremonies and provided such a feast of singing, story telling and sport making as will not soon be forgotten. Mr. Hooper was untiring in his energies to entertain the visitors. In addition to a formal resolution passed by the association expressing their appreciation of Mr. Hooper's labors a more tangible evidence of it was expressed in a token which was tendered to him before the superintendents and their friends took their departure from the capital city of old Virginia, which closed the ninth annual convention.

**PRESIDENT'S ADDRESS.**

It seems to me fitting that the opening address should review in a general way the past work of the Association in order that new members may be placed as nearly as possible on the same footing with those who have attended former meetings. It should also outline the work to be done in the future.

The Association has been favored in many ways. Its first president was a man full of years and experience, but abounding also in that enthusiasm which is supposed to distinguish youth; its second president, a man of culture and refinement with that good natured generous disposition that endears itself to all. Its third presiding officer, who took charge of the meeting at Minneapolis in 1893 and the meeting at Philadelphia last year, furnishes an example of energy combined with good judgment that must stimulate all who come in contact with him at these meetings, to greater industry and greater thoughtfulness. But fortunate as we have been in securing the services of these men, we have been still more fortunate in having the controlling influence or spirit that has very largely guided and directed our efforts; that of the late Adolph Strauch, whom I think you will all concede to have been the most artistic in his taste and most progressive in his ideas of what a cemetery should be, of any man that has lived in this country. Many of you have heard me praise Mr. Strauch before, but I think I have never given him more praise than was his due. We seldom acknowledge our debts too often.

Our first meeting could not have been held in a more suitable place than Cincinnati, because there we could see Spring Grove, which in many ways furnishes an example of what a cemetery should be. We have learned from it and from the papers and discussions at our various meetings during the last eight years, that a cemetery should resemble a park; that its lawns should be continuous over an entire section; that its drives should be reduced to the number actually needed to allow carriages to come within a reasonable distance of each lot; that these drives should have easy grades and should generally be curved, that they should be properly drained and properly constructed so that their surfaces will be smooth and durable, and should be kept in good repair, on the principle that "a stitch in time saves nine"; that there should be a variety of trees and shrubs arranged in groups so as to produce pleasing effects in themselves and pre-



serve desirable views; that natural beauty, due to undulating ground, native growth, distant views, bodies of water, or any other feature of the site selected for a cemetery, should be treated in a way to make it enhance the beauty of the place for all time to come. The characteristics of different trees, shrubs and herbaceous plants have also been studied with reference to their hardiness, their appearance at different times of the year, and their desirability for use in cemeteries.

We have had papers and discussions in regard to monuments and headstones, and it has been generally conceded that the stone work usually seen in a cemetery detracts from its beauty; that monuments (using this word in its ordinary acceptation) should be few and far between; that they add nothing to a man's reputation and do not prolong his memory; that the endowment of a bed in a hospital, a scholarship in a college, aid to a library or public art collection, a park for one's city, or any act of thoughtful kindness or charity that will benefit succeeding generations of the living, is a far better monument than the usual structure of stone; that of monuments placed in a cemetery, nothing is more suitable than a tree, a live monument, typifying in so many ways the life of man. It is held almost unanimously by members of our organization that headstones or grave markers should not project above the ground and that there should be no copings, railings, fences, hedges or other visible divisions between lots.

Much has been said in our meetings by members of the Association and others, about funerals. A large attendance at a burial is considered in poor taste, and there are not wanting those who believe that funerals are relics of barbarism that should be abolished in all intelligent communities by the good sense of the inhabitants. Why should not a burial be a private family affair, like the sickness that preceded it? Is it not a fact that the preparation for a gathering of friends and neighbors, the sermon, more often long than short, and frequently purposely intended to stir up the feelings of the listeners, the going to the grave, and the gaze of strangers, all add to the burdens and sorrows of the family from which one member has dropped? The wearing of mourning is also disapproved by many who have spoken on the subject.

Cremation has been the subject of papers and discussions at some of our meetings, and while I cannot say that this method of disposing of the dead is approved by many members, I think it is true that nearly all believe in the quick return of a dead body into the elements of which it was composed. They do not believe in attempting to preserve a body in mausoleums, or stone, slate or zinc lined boxes.

The effect of cemeteries on health has been quite fully treated. The conclusion arrived at being that when well regulated—as, of course, all cemeteries superintended by members of the Association are—they were not injurious.

I have thus far touched briefly on some of the subjects that have claimed the attention of our Association in the past, but for a complete knowledge of our work thus far, you must read our published reports and the articles that have appeared in the monthly periodical, to whose columns many of our members contribute. At our present meeting, drainage, greenhouses, boundaries, starting new cemeteries, native trees and shrubs, grading, and other subjects will be considered. The field of discussion is, however, not yet exhausted. We have had little on the botany of plants, how they grow, how they are propagated, how long they live and where they should be planted. Papers would be valuable which called attention to characteristic features of different forms of vegetable growth so that when looking at the plants mentioned we could see more things to interest and please us. We ought to have papers on the birds that live in cemeteries, giving their names, their colors, their habits, when they come, when and where they make their nests, how they sing, at what season they stop singing, and when they depart for their winter homes. A single species, as the brown thrush, the robin, or the cat bird, might be sufficient for one paper, especially if this paper contained some extracts from Thoreau and Burroughs as well as personal observations. The English sparrow would not be such an agreeable subject, but it certainly ought to be considered. There are certain quadrupeds, too,—squirrels, gophers, chipmunks, moles, rabbits, mice, etc.—that should receive favorable or unfavorable mention.

We have had papers on landscape gardening in cemeteries, but there still remains much to be said, or, if not said, to be shown. In landscape gardening, as in painting, one gets a better idea from seeing the picture or the view than he does from any description that can be given of it.

I have sometimes made what I call notes of the season giving an account of the weather, the arrival of birds, the flowers in bloom, the aspect of the foliage on different trees and shrubs,

etc., and have regretted, when reading them over two or three years later for the sake of comparison, that they were not made oftener. Such notes, while they might not furnish anything that would be of general interest to our Association, would be of value to the members making them. Our organization should aim to encourage local observations and local efforts that will make each member more efficient and useful in his work.

At one of our earlier meetings, an excellent article was read on the Ideal Cemetery. It pictured briefly the cemetery of the future. I wish we could have a paper on the future of our present cemeteries. Mt. Auburn is said to be the oldest cemetery in this country, but the generation that saw its beginning has not yet passed away. Most of the leading cemeteries of Europe are not very old. What will become of them in the comparatively short time of one hundred years, or what will be their condition in two, three, or four hundred years from now? We know of the efforts made by the Egyptians and other ancient peoples to preserve human remains, and of the unsatisfactory and repulsive results. Are we doing any better, or as well as we ought to do? A thoughtful, rational discussion of this subject would broaden our ideas and help to solve any question that may arise in regard to the treatment of cemeteries at the present time.

Mr. Norton, in his address before the Association, said "It is a somewhat strange thing that absolute dominion over any portion of the earth's surface should be given to a living man, but that any portion of the earth should be given absolutely in fee and forever to a dead body, set off and preserved eternally, simply to mark the spot where a dead body was taken back into the elements of earth, seems to me in itself a strange idea." Here is another text for us to consider. In its discussion we ought to call to our aid those engaged in other callings than our own. Is it necessary that the bones of our forefathers should be disturbed that buildings may be erected in their places? Such a disturbance is always revolting. Is there not some way that the land could be kept sacred to the memory of the departed and still serve the living? What more fitting and useful future could there be for a burial place than that it should become a memorial park where everyone could come and enjoy trees, shrubs, flowers, beautiful landscapes, birds, quietness and rest? What other disposition of the land would guarantee in a more effective way that our ashes or bodies should rest in peace? I am sure it would not hurt us if children played over our graves a hundred years from now, and if some lover should at the time bring a maiden fair to enjoy with him the moonlight of a summer night, he would be quite welcome to enjoy the seclusion the shade of a tree I had planted would give him, and I would keep faithfully any secrets he might divulge.

A cemetery generally brings to mind, even to those who have never had occasion to use it, the idea of sorrow and grief. It seems to me that it would be proper for us to consider from a purely rational point of view the subject of grief on account of death. May it not be that there is more happiness in the world on account of death? Does not the shortness of life stimulate exertion, and provide comforts and luxuries that would not come with a continued existence? Does not each period of life—childhood, manhood, old age—have its new experiences and joys which would wear out if kept too long? Considered abstractly and unselfishly, what matters it whether the good and beautiful things of this world are enjoyed by ourselves or our children or grandchildren, as long as they are fully enjoyed? I have spoken of the life of a tree typifying that of man. A storm comes and tears away a limb from a tree, just as disease or accident may take away a member of a family. With a tree, the wound begins to heal at once. Each successive layer of growth partly covers it until it disappears. Ought it not to be so with mankind? Do men wish to be mourned for when they die? If they do, they are selfish. For my own part, I sympathize fully with the lines from Pope, where, after describing the pleasures of a quiet, rural life, he says,

"Thus let me live, unseen, unknown,  
Thus unlamented let me die,  
Steal from the world, and not a stone  
Tell where I lie."

The influence of a superintendent outside of a cemetery is another topic that I would suggest for future discussion. The outdoor life which he leads gives him unlimited opportunity to study plants and animals and the beauties of nature, and the knowledge which he thus gains may help to beautify the homes and residence grounds of the living. This opportunity to develop the artistic side of his nature should make him lead a happy and useful life.

*O. C. Simonds.*





GARFIELD PARK—"THE GLEN," CHESTER CREEK.

#### The Parks of Duluth, Minn.

The comparatively young, but enterprising and rapidly growing city of Duluth, has shown great wisdom and foresight in regard to her public parks. Several tracts of land of more or less acreage have been secured, easy of access, and moreover of historic interest, and which have been dedicated to the use of all her citizens forever.

This early recognition of the necessity, to say nothing of the business acumen displayed, of acquiring and setting aside certain areas of land for

park purposes, will result in unquestionable advantages in the future, and in the matter of Duluth, preserves right in the midst of her population, tracts of wild, natural scenery, which by care and study of the officials in charge, may make the Duluth park system unique in itself and unsurpassed by any other city of the Union. More than this, as the neighboring country grows and improves about the city, her natural and wild parks, will be an attraction which will redound to the welfare, moral and physical, of this city by the lakes.

By the courtesy of the Board of Park Commissioners, through its secretary and superintendent, Mr. H. C. Helm, two characteristic views are given: One "The Glen," Chester Creek, Garfield Park; the other, East Branch Falls, Lester River, Lester Park. An enchantment steals over one while looking at these refreshing pictures; one can almost feel the actual effects on the human system of the delightful combination of water, woods and rocks, and hear the music of the falls, roaring or gurgling in its many moods as the water makes its way to its rest.

The system includes some six parks, viz: Lincoln Park, Central Park, Garfield Park, Lester River Park, Cascade Square, Portland Square, and connecting boulevards or parkways.

Lincoln Park comprises about fifty acres lying in the valley of Miller's Creek, which traverses its entire length. The width of the tract varies from four hundred to eight hundred feet, which it makes by a succession of rapids and falls, through granite bounded limits, forming here and the reswirling pools, whence it renews its vigor and terminates its career in the park in a beautiful cascade called the Lower falls. This tract is heavily timbered with young and healthy trees of many varieties, and with its granite outcroppings and boulders form a most romantic and attractive resort.

Central Park, of one hundred acres, contains the highest point of land on Lake Superior, 600 feet above its level, and the land first sighted by the lake pilot. Its roadway reaches a point 500 feet



above lake level. It presents a stern appearance of moss covered granite, and is cone like in aspect, but is covered with a growth of young forest trees. The views from this park are varied and beautiful to a degree. It possesses two miniature lakes, surrounded by grass, connected by a culvert which discharge their waters over a granite ledge, terminating in a fall of about thirty feet. Roger's boulevard encircles the cone and makes a grand drive.

Garfield Park contains about one hundred and twenty-five acres, taking in the valley of Chester Creek, and lies generally in a deep canyon. Chester River traverses its entire length, and in its turbulent course forms a series of varied water scenes

Cascade Park, not far from the business center, is in course of improvement, and Portland Square Park, differs entirely from the others in that it will be artificial. In addition to the parks enumerated it is designed to finish up seven other small parks, as breathing spots in the city, which will be taken care of as the city's needs call for them.

There are fifteen miles of boulevards finished and in course of construction, which connecting all the parks, skirting the lake, and having unsurpassed scenery will enhance the beauty and value of Duluth's park system. It is the design of the Commission while employing modern ideas in general, to bending its energies towards preserving the



LESTER PARK—EAST BRANCH FALLS, LESTER RIVER.

hard to imagine. In some places its passage is so restricted that it becomes a roaring torrent, in others it spreads out into beautiful cascades. Garfield Park is perhaps in its wild nature, the most attractive of the whole system.

Lester River Park lies about six miles east of the business center and consists of about twenty acres. Like Garfield it rests in a gorge of the Lester River through which the stream rushes and plunges on its road to the lake. In one part it divides, leaving an island, which has become popular picnic grounds, reached by rustic bridges. The authorities are giving much attention to this in the way of improvement.

natural effects, so lavishly placed at their disposal.

One of the principal difficulties encountered in landscape work about Duluth is tree planting. Owing to the physical conditions of the locality, scarcity of suitable soil, etc., transplanting and caring for trees require most exacting attention, but sufficient experience has been already acquired as to secure good results in the future.

The total amount expended for land has been \$269,263.08, and the estimated value of land donated amounts in addition to 228,000, making a total value, not including improvements, of \$497,263.08 and a total area of 211 acres. The system is designed to include about 400 acres.



**The Smith Mausoleum,  
Charleston, S. C.**

The mausoleum, illustrated herewith, is erected in Magnolia Cemetery, Charleston, S. C., for the H. B. Smith family of that city. The exterior is constructed of Georgia granite, and the interior and door frame of Italian marble, as also the statue of Faith over the doorway. It contains eight catacombs and is lighted by a handsome stained glass window in the rear. The door itself is of bronze. The dimensions of the structure are: height thirty feet, base eighteen feet square.



THE H. B. SMITH MAUSOLEUM, CHARLESTON, S. C.

The mausoleum was designed and built by Mr. E. T. Viett, Architect, for the Viett Marble and Granite Works of Charleston.

**Notes on the Rhododendron.**

The Rhododendron is one the best of flowering shrubs, its glossy dark green leaves offering all the year round, a very attractive and pleasing effect, while it excels in blossom all other evergreen shrubs in its masses of brightest flowers.

The following varieties are those most grown: Rh. ponticum, blooming the end of June in violet clusters, and the Rh. arboreum maximum, and catawbiense varieties which flower in all tints between white and purple from the beginning of June.

After the flowers drop the greatest care must be taken to give the plants plenty of water at the roots, and liberal sprinkling to the leaves and branches to start a good sprouting of new shoots. As these young branchlets ripen and set end buds, the watering should be diminished. This period should be completed from the beginning to the middle of August.

The plants now require to be kept dry, and to obtain this condition in moist locations it is advisable to take up the whole root-ball and to place it loosely in or on top of the soil, until a sufficient rest from growth is obtained, but shriveling of skin or leaves must be avoided. In a practical way the degree of moisture contained in the plant can be

ascertained by curling the leaves between the fingers,—the less one can do so, the more moisture. This general treatment is only possible with smaller plants and is mainly adopted for forcing purposes.

The beginning of September is the best time for transplanting the older plants and they should be thoroughly tramped around to secure a good and firm standing. Transplanting in spring in most cases, mars the prospect of good growth, though it is the only time for the new arrivals.

Rhododendrons may be grown in any rich soil, but a soil composed of leaf mold, muck and peat is best, and young plants should be mulched to protect their roots the first year. The most profitable time for the use of manure is during the growing period, and winter is also a good time. Cool manures containing ammonia, phosphorus and kali are good, as also bone meal and cow manure, solid and liquid.

The trimming of the plants is best done after the flowers drop. Branches with a few leaves, by careful treatment produce several sprouts; and a timely pruning is quite advisable for older plants which are liable to become quite bare on the lower parts. It is also good policy to preserve the strength of the plants by removing all seed stalks.

Rhododendrons in their natural state are undergrowth plants in light woods, and will therefore bear some shade, and they do better with shelter from cold and variable winds, which are their arch-enemy, my last years experience has confirmed



this. As will be observed in our native woods the hardy Azaleas, such as: *mollis*, *pontica*, *amoena*, etc., are closely related to the *Rhododendron*.

The possibilities with *Rhododendrons* in garden and landscape work are manifold. Small gardens admit of only the use of single plants, in groups more or less round or oval in shape, which when surrounded or bordered with such summer annuals as *Mignonnette*, *Phlox*, *Petunias*, *Morning Glory*, etc., very graceful effects are produced.

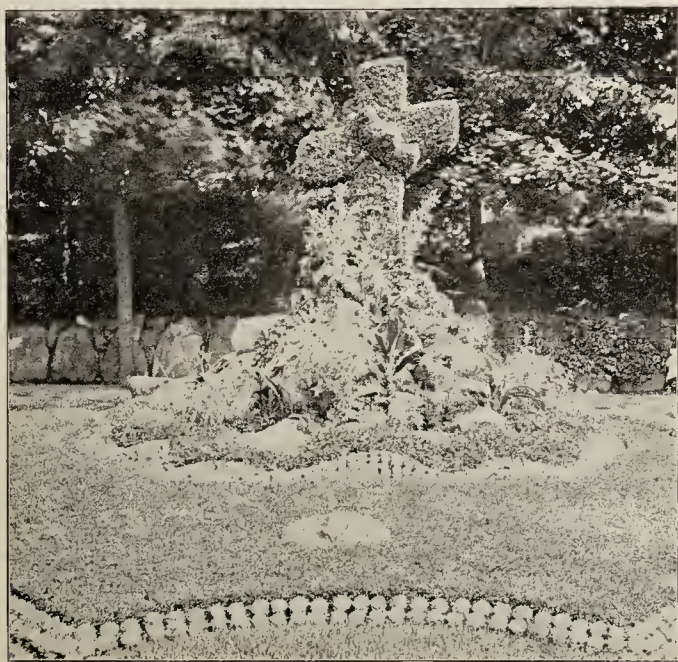
Their application in open landscape work is much more varied. Planted against a back ground of spruces or other evergreen and dark leaved plants, or perhaps on a slope, *Rhododendrons*, distributed in masses of various shades, or singly, with proper regard to taste and beauty, will give most attractive effects. Intermingled with rocks, ferns, smaller evergreens and other plants, growing in light shade, this class of plants will form a pleasing variation.

An extension of their application to produce variety in charming effects is to plant them along a driveway carried through the woods, which would be quite natural conditions; but to continue the greatest interest, changes of elevation might be taken advantage of to introduce other means to create indefinite combinations. For the luxuriance of the bright flowers though unquestionably grand might nevertheless become monotonous.

*William Stuppe.*

#### Gardening in Harmony Grove Cemetery, Salem, Mass.

Illustrated herewith is a piece of floral work from Harmony Grove Cemetery, Salem, Mass., representing the Rock of Ages, containing 14584 plants. The cross is about 2 feet high on a frame-



ROCK OF AGES, HARMONY GROVE CEMETERY, SALEM, MASS.

work 4 feet, which is surrounded by rocks. The cross and crown is composed of *Alternanthera*, and the rocks are interspersed with a goodly variety of Ferns, Rubbers, etc. The groundwork of the bed is of *A. nana* and the letters of *A. rosea*, with a border of *Echeveria Secunda*, which makes an attractive display.

A cactus bed has also been an object of great interest in this its first year, but so much experience has been gained, that Mr. Geo. W. Creesy, Supt., says that some decided improvements will be the result for next season.

The aquatic garden, or lily pond, set amid delightful landscape, has been a grand success in this cemetery, and involving less of the artificial than most ornamental gardening, makes excellent returns in the interest it creates.

The cemetery ought not to be divided into strictly ornamental planting areas and burial grounds in such a manner, so as to form a distinct distribution of one or the other, as may be found in many cemeteries, where the principal attractions are luxuriantly laid-out foregrounds with arbors, fountains, lakes, and elaborate buildings, but should rather be treated with continuous arrangement of extensive lawns, arranged irregularly with belts of trees and shrubs, thus forming back-ground for all groups of lots, as well as affording shade, seclusion and repose. The principal aim should be directed toward securing these extensive meadows and lawn sections by a well-planned subdivision, with a system of inconspicuous drives, giving convenient access for burial purposes and for routine work upon the grounds, and with the view in mind to economize the actual planting areas of each section for the benefit of ample burying ground. Walks other than grass paths leading to separate groups of lots should be abandoned, and family lots grouped in a manner that all may be benefited by the above mentioned planting areas on what may be termed reservation grounds, for each section. These should be made permanent features of the general plan and carried out, and all other planting and embellishments considered secondary to the whole. Lot owners should be restricted from planting at all, unless they wish to contribute toward the general plan once adopted, and taught to sacrifice their individual wishes for the benefit of that plan.—*F. Eurich.*

Woodchucks are easily destroyed by pouring a tablespoonful of bisulphide of carbon on a ball of cotton batting wound over a stone the size of a hens egg. Roll the saturated ball into the hole and close it air tight with soil. The fumes will kill the woodchucks.—*Orange Judd Farmer.*



**Cemetery Accounting.—II.**

As intimated in the last issue the following paper which was read at the Fifth Annual Convention of the Association of American Cemetery Superintendents, held in Chicago in September, 1891, will be found, while concise, quite comprehensive. It was read by Mr. F. D. Willis, Secretary, Oakland Cemetery, St. Paul, Minn.:

It is a fair presumption that cemetery officials are not all expert accountants; and it is fair to presume that every association desires to keep its accounts that any lot owner may be able to understand the condition of its affairs.

Its income should be kept so as to show under proper heads from what source it is derived; and its expenditures should be classified and subdivided in such a manner, as that the trustees and executive officers may by care and watchfulness be enabled to practice true economy in administering its business.

To do this, data must be furnished showing, as near as may be, how the expenditures compare with the receipts from the various sources of revenue. While this cannot be arrived at with absolute exactness, it can be done so as to make a showing approximately correct,—near enough to serve a useful purpose.

The experience of the larger associations will bear out the assertion, that detailed monthly reports should be made to the trustees by the treasurer and the superintendent. The lot owner or intending purchaser, should first arrange with the superintendent, and should take from him a memorandum to the treasurer, who, having received the money therefor, should issue his orders to the superintendent by series and numbered, showing sales made, or service to be performed, with the amount paid stated thereon; and these orders should accompany the detailed report of the superintendent to the trustees, as his warrant for what he has done.

Hence it will be seen that the treasurer's and superintendent's reports will check one against the other.

The principal sources of revenue may be classified as follows:

- Sales of Lots.
- “ “ Single Graves.
- “ “ Flowers.
- Fees for Interments.
- “ “ Receiving Tomb.
- “ “ Mortuary Chapel.
- Charges for Foundations.
- “ “ Miscellaneous Labor.
- “ “ Annual Lot Care.
- Income from Investments for Permanent Care.

All disbursements by the treasurer should be made upon vouchers, certified by the superintendent or president to be correct, and for the use and benefit of the Association, and distributed to the

proper accounts; and finally audited by the finance committee, or an auditor.

The monthly expenditures being largely on account of the pay roll, the amount should be approximately sub-divided and charged to the several sources of revenue, general expenses and improvements made upon the grounds. In the case of any special improvement, there should be an account kept of it until completed, when it may be transferred to an account which for the want of a better term might be called “Specific Improvements.”

Thus there will be under one title in the statement of the treasurer, the totalized amount of completed expenditures for mortuary chapel, office, dwelling, barn, greenhouses, water system, entrance gateway, etc., etc.

The amount received for permanent care of lots should show certain facts, and may be kept as follows, viz:

- Permanent Care Fund Principal.
- A credit of total amounts paid in or set apart.
- Permanent Care Fund Invested.
- A debit of total investments owned at par value.
- Permanent Care Fund Premium and Discount.
- The difference between par and purchase price of investments.
- Working Fund.
- A debit of expenditures for care and a credit of income from investments.

In this connection it might be said that some Associations place all their securities in the direct custody of a trust company, the interest coupons being turned over by the trust company to the treasurer as they approach maturity; but the securities are only withdrawn upon the joint written order of the finance committee. This method furnishes as nearly absolute security as can well be devised.

The unsold realty which the association owns may be taken up as an asset, appraised at its value in acreage for purposes other than a cemetery, and at the end of the fiscal year this account credited with the number of acres sold, at the price it is carried on the books, and charged to Lot Sales. This would show the profit on sales over acreage value. Or, if preferred, the realty could be computed and carried as an asset at the prices held for sale by the square foot, and the total sales credited at the end of the year. The former method seems preferable.

If the accounts are kept as is advisable by double entry system, a monthly transcript from the ledger in the form of a trial balance sheet, will show the status of the Association.

In the execution of this sacred trust, undertaken by the trustees of most cemeteries as a labor of love, or a duty to be performed, everything which helps to make things plain to them at their meetings aids good management.

A printed leaflet of the annual statement of the treasurer, in the hands of every lot owner, brings the association to their attention, and acquaints them with its condition; and should secure a greater interest in beautifying this our final resting place.



◁ PARK NOTES. ▷

Mr. Joseph Hill of Pontiac, Mich., has made a gift of a fountain to the Newton Park, for the citizens of Sussex Co., N. J. Mr. Hill's proposal was to erect a drinking fountain for men, horses and dogs, and his suggestions have been carefully followed. The architect is Mr. John J. Merriam, of Summit.

\* \* \*

Among the many towns in which new parks are under consideration may be mentioned, Newton, Kan.; Riverside, Calif.; Contoocook, N. H., by gift of Mrs. C. L. George; Eurcka, S. D., by gift of the Milwaukee Co., of that place; Oil City, Pa., by gift of Mr. Hasson; Carleton, Mich.; Menlo, Ia.; Greenfield, Mass.

\* \* \*

Not long ago London, in order to open a breathing spot in a densely crowded neighborhood, cleared a space of less than two acres at a cost of more than a million dollars. The realization of the necessity of this kind of philanthropy which the closing of the nineteenth century demands as right, was never better illustrated.

\* \* \*

Mr. S. C. Evans, a public spirited citizen of Riverside, Calif., has offered to the trustees of that city a tract of land for park purposes at Fairmount Heights. The grounds appear to be admirably suited for a park, a running stream making a lake of easy acquisition. Mr. Evans will need no further monument than Evans Park.

\* \* \*

The Sheridan Road Association, which has in its care the construction of the beautiful driveway from Chicago, northward along the shore of Lake Michigan, the length of which may be indefinitely extended, has been presented with nine fountains by different donors, to be placed along the road between Chicago and Lake Forest, a distance of some thirty miles.

\* \* \*

The bids for the construction of the wing of the Brooklyn Institute of Arts and Sciences, the portion of the great building to be at present commenced, were opened on August 20. They ranged between \$257,926 and \$252,320, a remarkably close showing. The work is to be completed by January 1, 1897 under penalty. The architects are Messrs. McKim, Mead & White, of New York.

\* \* \*

The Association organized to make arrangements for a memorial to Serjeant Charles Floyd, the intrepid member of the Lewis and Clark expeditions, who lost his life in an exhibition which opened up a large part of the north-west, besides a monument, propose to secure a park in which to locate the monument. The headquarters of the Association is Sioux City, Ia., and E. W. Skinner is acting secretary.

\* \* \*

Chicago, like most of our large cities, is lamentably deficient in small parks—breathing places for its less fortunate inhabitants. It is a good sign, however, that attention is being centred on the fact, and it may be expected therefrom, that such a condition will not exist many years longer. The trading spirit to which the city owes its commercial position, has held undisputed sway during most of its existence, which is perhaps well expressed in the regret of a citizen, that so much valuable space was wasted in the strip of green sward on the western front of its government building.

\* \* \*

Few people realize that a great park system is, in a certain respect, similar to other great enterprises for public necessities—it requires constant labor night and day. The pay-roll for the South Park system of Chicago for the month of August contain-

ed 923 names, but this number is greatly reduced for the winter work. To keep the grass in order a force of over 100 men are engaged all night long for watering in the dry spells, and this constant care accounts for the comparatively fresh appearance of the parks of our large cities at all times. A water famine is a hard experience for the park.

\* \* \*

Dubuque, Iowa, has a project well started to commemorate its founder Julien Dubuque. His grave is on a bluff outside the town, it is arranged to create a park of thirty acres near the spot on the site of a village of the Sacs and Foxes. In laying out the park it is intended, in making roads and footways, to follow the trails and paths trodden by the red aborigines as far as possible. There is a grove of natural timber, and a winding way up from the river through a valley to the top of the bluff. A beautiful spot can be created. The monument is to take the form of a castle on the Rhine.

\* \* \*

As might have been expected the freedom accorded the bicycle, in the midst of our busy city life, has resulted in the necessity of restrictive regulations. The bicycle in our parks and on our thoroughfares has become really more dangerous than ordinary traffic, from the noiseless manner of its movement, and many fatal accidents are being daily recorded. Unfortunately for their future freedom, bicyclists have labored under the mistaken idea that they can carry the privileges of the pedestrian into the roadways, and make the walking public take all the responsibility for its own safety; when undoubtedly the fact must be that when using the road on rapid wheels the cyclists place themselves on the plane of other vehicles, and must yield to the pedestrian what the law accords him.

\* \* \*

The liberal policy displayed by Boston in the development of its park system has made it a study for other large cities. The system was authorized by popular vote in 1875 and construction was well begun in 1879. Mr. F. L. Olmsted was given a partially free hand to devise the best practice his long experience dictated, which resulted in a scheme involving a series of distinctive, individual parks, each united to the other by a chain of drives and walks, making a continuous parkway many, many miles in length. The characteristics of the landscape in the vicinity of Boston are so varied as to largely give special features to each of its parks and the genius of the designer was devoted to emphasizing them in each particular instance. Boston now has some 14,000 acres of park lands under its control and some \$12,000,000 has been expended, with no diversions and no politics.

\* \* \*

The new parks of the city of Brooklyn, N. Y., for which some \$2,000,000 have been expended are receiving their names. In the order of their importance, some have been designated as follows: Brooklyn Forest, The Dyker Beach Park, Canarsie Beach Park, Bensonhurst Beach, Lincoln Terrace, Cooper Park, Irving Square, Saratoga Square and New Lots Playground. The largest is Brooklyn Forest, comprising 535 acres of land, much of it covered with fine woods, costing about \$1,100,000. The Dyker Beach Park, on the shore of Gravesend Bay, comprises 140 acres, and cost \$300,000. Canarsie Beach Park, will be about forty acres in extent; the cost of this property is \$110,000. Bensonhurst Beach Park, will consist of seven acres of upland, and possibly an additional 20 or 25 acres of submerged land, cost \$90,000. Lincoln Terrace Park will be eight acres in extent, obtained at a cost of \$120,000. Cooper Park embraces eight acres and represents a cost of \$55,000. Irving Square is six acres in extent and has cost \$70,000. Saratoga Square, also six acres in extent, cost \$120,000. New Lots Playground will be laid out in the Brownsville section. It is the smallest of the new parks, covering only three acres, and has cost \$16,000.



## CEMETERY NOTES.

In the Punic cemeteries of old Carthage, Father Delattre has already examined 125 tombs. He has found a painted terracotta mask, with oval face, short side whiskers and a close-shaven chin, and bronze rings in the ears; and also a disk of terracotta with a warrior on horseback in relief upon it, under the horse a running dog, and above the figure a lotus flower and a crescent moon.

\* \* \*

The prospects of a coffin trust at time of writing are not assured, discounts and division of territory appears to have been the stumbling block, and it will be a difficult thing to get over. The same questions have prevented other combinations against wholesome competition, and this combination will have many breakers ahead in the tendency to reform in funerals and funeral appurtenances.

\* \* \*

An Iowa exchange mentions one of its towns as having: "Laid out a new cemetery and is offering lots at 20 per cent discount until Oct. 1." It adds that "an option on a corner lot in an \* \* \* \* graveyard would be better than pools on a ball game in a contest between the \* \* \* \* church nines." This is business with a vengeance; real estate boom methods to dispose of realty in "God's Acre."

\* \* \*

As a means of preserving records the inscriptions on the tombstones of the old Bridge Street burying ground, Gloucester, Mass., have been carefully copied. The stone recording the earliest death is that to Rachel Baker, dated 1711, but one to Lieut. James Baker, who died in 1721, age 80 years, may have been erected earlier, its appearance indicating more age. For historical purposes, in connection with either local or state records, an accurate copy of the writing on old tombs should be preserved, and is likely to form a source of valuable information.

\* \* \*

A curiosity of Greenville, Hudson, Co., N. J., is the little cemetery on Linden ave., back of Bamber Hall. The entrance to it is by a six foot gateway to an alley by the side of the hall, and strangers would pass it by unnoticed. The plot of ground is about 50 feet square, situated at the rear of the building, which was originally left to the trustees of the church as a burying place for paupers, but it has been used for wealthier people. It appears to be full of graves and interments still continue, but it is poorly kept. The trustees of the church sold the land upon which Bamber Hall stands, and the present proprietor wants a license to run a billiard room and bowling alley, which is opposed by relations of friends buried in the rear.

\* \* \*

The mausoleum erected at Winchester, Mass., wherein lie the remains of Dr. Francis B. Hiller, is a costly piece of mortuary architecture, the total expenditure of which having been nearly \$500,000. The carved casket containing the body cost alone \$50,000, and a similar one is being placed at its side for Mrs. Hiller, under whose directions the tomb has been built. The building contains some 6,000 square feet, and its height is 75 feet. It has a dome resembling that of an Oriental mosque, the front being of Gothic design. Wrought iron and brass have been used most lavishly for the gates and other portions of the buildings, while the lamp which illuminates the post of the watchman, cost some \$10,000. The knobs to the outer doors are of solid gold, and the medallions on the caskets each contain some \$500 worth of gold.

\* \* \*

Prior to 1827 there was no public burial place at or near Memphis, Tenn., but the following year eleven acres was don-

ated which became known as Winchester Cemetery, and burials were continued therein until 1874, when the city limits overran the plot. In 1852 Elmwood Cemetery Association was organized, the Walker avenue tract bought and the cemetery incorporated by act of legislature. The name Elmwood was selected by lot and is not descriptive of the trees on the place. It contains eighty acres and has a section set apart for negroes. The first interment took place in 1853. The total number of interments exceed 29,300, of which some 900 are buried in the confederate lot and over 6,460 are negroes. From March 1, 1894 to March 1, 1895, 481 bodies were buried. In the past three years more money has been expended on improvements than during any similar period of its existence.

\* \* \*

The following story is told of Supt. Floyd, of Evergreen Cemetery, Deering, Maine, who will probably second the elder Weller's injunction, "Beware of vidders." At any rate it deeply concerns cemetery financial methods. A certain Portland citizen died and his widow purchased a lot in the cemetery, but did not pay for it. Mr. Floyd told her that it was contrary to the rules to bury a person in the cemetery until the lot was paid for. This made no difference to the widow. She went ahead with the funeral, had her husband's body carried to the cemetery and the coffin left on top of the lot, where of course no grave had been dug. Then she went to Mr. Floyd, and with tears running down her cheeks, said: "Mr. Floyd, there is Mr. S——, you can bury him or leave him on top just as you've a mind to," and away she went. Of course Mr. Floyd had to bury the abandoned coffin. There was no way out of it.

\* \* \*

In a public speech, the late Robert C. Winthrop, of Boston, thus spoke of the New England graveyard: The graveyard itself should be kept and cared for as the very apple of the city's eye. It should be made an ornament to the city, and not left as an eyesore. It should be preserved as by a solemn consecration, for all generations. It might well be adorned and inscribed, so as to attract the observation of our children and of strangers, and might even claim some recognition on a Decoration Day, or on the anniversary of the settlement of the city. At all events, it should be preserved as long as the city has an anniversary to celebrate, or a name to live in the annals of our land. The first fathers of New England, who sleep in these graves were compatriots and contemporaries of Shakespeare, and though they built no lofty rhymes, or immortal dramas, they founded a city and a commonwealth, which will hardly be disposed to bring upon themselves the reproach of having allowed such graves to be desecrated."

\* \* \*

An eastern inventor has devised a scheme to prevent burial alive, which he calls a grave signal. It consists mainly of a tube fitted with air valves, which passes through the earth into the coffin. It is so delicately adjusted that the least motion of the body inside the coffin affects these valves and motion is communicated to a register above the ground. It may not be generally remembered that in a certain "Gods Acre" in Munich, a test is always applied to every body brought there for burial, and a building is devoted to the purpose. The bodies are raised to a reclining position in their coffins, and upon the thumb a kind of a thimble is placed which is connected by a wire carried through the ceiling to apparatus in a room above, which gives a signal should any movement occur below. Some years ago it used to be said that no twitch of the wire had been noted for fifty years, and that in consequence a sentiment was growing that the proceeding was unnecessary and obnoxious. But it is a municipal law. All visitors on the approach of sickness give Munich a wide berth.



## ≡ Correspondence. ≡

Evansville, Ind., August 12, 1895.

*Editor Park and Cemetery:—*

DEAR SIR:—I love to see a nice, clean, bed of flowers in a cemetery, and who is it does not. But I think a person is committing a great sin, who will dig up a beautiful blue grass sod to make a flower bed and then let it grow up to weeds; and they ought to repent early in sackcloth and ashes, and turn to the grave of their beloved ones to ask forgiveness and to make a vow right there to do better in the future.

When the immortal "Little Nell" asked her friends to plant something near her grave that had seen the light, she did not think they would be so careless as to let the weeds choke it to death.

Yours Truly, J. S. GOODGE.

The report of the president of the Allegheny Cemetery to its corporators, shows quite distinctly the effects of hard times on cemetery properties. A strange coincidence lies in the fact that during the last financial year the same number of lots were sold as in the previous year, viz., fifty-five. The point denoting the hard times is that last year the average price for lots was \$279 while for the previous year it was \$537. There are 5,084 lot holders who have up to this time expended about two and a half millions of dollars in the cemetery. This last year only some seventy thousand dollars were expended on monuments, tombs, etc. The last year was very severe on the best trees, some 100 having been removed.

## ≡ CREMATION. ≡

John Stover Cobb says in the *Urn*: "Dr. F. Julius Le Moyne, of Washington, Pa., must be regarded as the pioneer cremationist of the United States. In the year 1876 he built a furnace for the purpose of ensuring the incineration of his own body and with the design of familiarizing, to some extent, the American public with the practice of cremation. It is true that, a short time previously, an attempt had been made, in New York City, to form a cremation society. Owing to the financial stringency of the times and opposition of public opinion, this attempt, however, was not successful. He built, at his home, the first crematory in the land and, for a period of more than eight years, this little country town of Pennsylvania was the only place within the borders of our great Republic, where a human body could be disposed of in rapid combustion."

"I may mention that the published figures for 1894 include 11 months only of that year, and are given as 808. This is equivalent to an average of 73 per month, which will yield about 876 for the entire year, \* \* \* while these figures comprise, of course, a very small percentage of the number of

deaths, yet if the proportionate increase in the same number of years to come is as great as these years, we may expect that, in 1910, cremation will be the rule, burial the exception."

At the Forest Hills crematory, in a little more than a year, 120 bodies had been cremated and a great impulse would be given to the movement when the chapel, already designed, is erected.

In the substitution of cremation for burial the welfare of mankind would be subserved, and he urged all friendly to the new movement to help in completing the building. In the crematory chapel no limitations would be placed upon any religious belief, and every one would be able to witness "a reverent and beautiful way of caring for the dead."

Dean Hodges speaking of cremation says: "Cremation will tend to do away with cemeteries, and bring in two new places for the disposal of the dead. The house of the departed may be set in the midst of the city, and proper respect be paid to the dead without regard to persons, to heroes, saints and citizens. Such a building would offer large opportunities to art and artists. It would be a building that would uplift the thoughts of all who enter, made splendid perhaps with paintings, teaching the great truths of the present and the future, and taking life away from debasing things and influences. There would be no pagan shapes in stone, but memorial windows, through whose pictured panes the sun would tell the story of the cross as the symbol of the life to come.

### Cremation.

BY DR. FREDERICK PETERSON.

Thou tender blossom, more than human,  
Because so fair and pure and humble,  
O lovely flower, how could I doom one  
So dear to droop defiled—to crumble  
Like man and woman!

And so, thou flower of flowers, I swore it  
That one thing, one, should not so perish,  
That mocking fate should laugh not o'er it,  
Not alway mar what most I cherish,  
While I deplore it.

Thus on the white hot coals I place thee,  
Among the ferns of some gone aeon;  
In shining vesture they do grace thee,  
And perfumes as from isles Aegean  
Do soft embrace thee.

No taint, no blemish, naught but ashes—  
Of such fine death thy frame is worthy:  
The ermine couch with damask flashes,  
Quick change of heavenly back to earthy,  
No soul abashes.

O bud half open, thy sweet splendor  
Is risen from the fiery portal,  
And atoms which through stem so slender  
Had crept into a bloom immortal,  
Their work surrender!



## Extracts.

Swamp land or steep side hills may be so developed and beautified in ways that will suggest themselves to the true landscape gardener, as often to transform unsightly localities into the most attractive little parks or public grounds, and thus turn into actual profit what would otherwise be waste land.

Judicious planting in such places has perhaps as much to do with the beauty of the grounds as anything else, and in this we cannot do better than to study nature. Trees and shrubs should be planted in masses of thick green to give the effect of impenetrable woods as one looks at it, and in such places and shapes as to cut off views here and open others there, but not with any apparent effort in that direction. By planting trees on the top of a slope and thick shrubbery meeting it from below, we increase the size of the hill in appearance, as there will be a continuous line of green from the grassy slope to the very top of the trees, and thus what may be a very insignificant rise in the ground is transformed into quite a hill when viewed from a distance.

When we come to planting, we can frequently find native shrubs and trees in the woods that can be procured for the taking, which by judicious handling in the transplanting, will give just as good effects in masses as more expensive stock from nurseries, and which we may be sure will stand the climate.

And among the shrubbery we may plant hardy flowers, also, to add a bit of bright color to the sombre green. What strikes the eye as more beautiful as we drive along a country road than the wild flowers, golden rod, wild asters, daisies and hundreds of others peeping through the leaves of a dense mass of low shrubs, or growing in an irregular border of bright color on the outside. Surely this is prettier in its place, than a stiff carpet bed, and requires less care and is much less costly.

R. D. Cleveland.

## Publishers' Department.

NOTICE TO SUBSCRIBERS. If this notice is marked with a blue pencil it indicates that your subscription to PARK AND CEMETERY has expired and a renewal of same is solicited.

Park Commissioners and Cemetery trustees are requested to send us copies of their reports.

Photographs and descriptive sketches of interesting features in parks and cemeteries are solicited from our readers.

PARK AND CEMETERY wants the names of every park and cemetery official or employee who would be likely to be interested in this paper. To the many subscribers who have sent in such lists of names, we return our thanks. There are many more that we should hear from.

Subscribers are again reminded that we want brief notes on any feature of park or cemetery work that will be of general interest. PARK AND CEMETERY is the only publication of its class and earnestly solicits the co-operation of subscribers in making it a help to all identified with such work.

## RECEIVED.

Received from Mr. C. D. Phipps, Supt. of Cemetery of Franklin, Pa., and one of the committee, the notice in "ye olde time" style of the celebration of the one hundredth anniversary of the founding of the city of Franklin, which occurred 1795. The document bears an impress of the city seal.

From Geo. W. Creesy, superintendent of Harmony Grove Cemetery, Salem, Mass., photographs of Lily Pond, Cactus bed, and Cross and Crown bed; interesting subjects of this cemetery.

Letters and instructions of O. C. Simonds, landscape architect, to the Quincy Park and Boulevard Association, Quincy, Illinois.

Reports of president and Superintendent to the corporators of the Allegheny Cemetery, Allegheny, Pa.

## TESTIMONIALS.

*Editor Park and Cemetery.*

Enclosed find subscription to *Park and Cemetery*. I hope to be able to induce our cemetery committee to become subscribers. We are now laying off a new addition to our cemetery and I think enough good, modern, ideas could have been obtained from your paper to have more than repaid the outlay.

J. B. Russell, Macomb, Ill.

*Editor Park and Cemetery.*

Please find enclosed my subscription to *Park and Cemetery* for 1896. I sincerely hope that it will receive sufficient encouragement to become a fortnightly issue. Its pages are so full of valuable hints to any one interested, and especially to me, a young man in the profession. I have received information from its pages that has saved my company many dollars.—one especially in connection with digging graves, by the use of trench and salt, which was a grand success as we have very severe frost. Again hoping to see a semi-monthly issue.

JOSHUA P. CLAYTON, Supt.  
St. John, N. B. Rural Cemetery.

*Editor Park and Cemetery:—*

I herewith enclose subscription to PARK AND CEMETERY. I like the widening of your field to Park and Cemetery as the paper thereby is adapted to wider usefulness.

Robt. Watson,  
Northfield, Minn.

*Editor Park and Cemetery:—*

You will please find money order for my subscription to PARK AND CEMETERY for another year. I find your publication of great use to me as teaching me how to control a cemetery, and its multifarious concerns aright. J. R. Ruel, President Rural Cemetery, St. John, N. B.

*Editor Park and Cemetery:—*

Please renew our subscription for the PARK AND CEMETERY for this year. We consider your paper a very valuable assistance to any one in charge of a cemetery. P. H. and F. M. Webster, Mngrs. of Oak Hill Cemetery Association, Bradford, Pa.

## Iron Solvent.

A preparation put in the form of a powder for removing **Iron Rust, Acid Stains** and other discolorations from monumental work. It has been tried by monument dealers and found to give entire satisfaction. Iron stains are permanently removed without injuring stone. \$1.25 per package mail postpaid

R. J. HAIGHT, 334 Dearborn St., Chicago.



# PARK AND CEMETERY.

FORMERLY THE MODERN CEMETERY.

A Monthly Journal Devoted to Parks and Cemeteries.

R. J. HAIGHT, Publisher,  
334 Dearborn Street, CHICAGO.

Subscription \$1.00 a Year in Advance. Foreign Subscription \$1.52

## CONTENTS.

EDITORIAL.....	127
COUNTY PARKS,.....	128
*LILY PONDS AT LINCOLN PARK, CHICAGO.....	129
*TROPICAL HOUSE, FAIRMOUNT PARK, PHILADELPHIA,.....	131
*THE MONUMENTAL CEMETERY, MILAN, ITALY.....	132
GARDEN AGRICULTURE.....	134
*CONVENTION NOTES.....	136
TAXATION OF CAPITAL STOCK CEMETERY COMPANY— VALUATION OF LAND FOR PARK PURPOSES—A NEW WISCONSIN CEMETERY LAW.....	139
EPITAPHS.....	140
PARK NOTES.....	141
CEMETERY NOTES.....	142
*CEMETERY ACCOUNTING III.....	143
PUBLISHER'S DEPARTMENT.....	144

\*Illustrated.

AMONG the important deficiencies which foreigners visiting our shores notice soon after arrival, is the lack of those public conveniences which they have been accustomed to find in most European cities of importance. And while this is true of the cities as such, it is equally so as regards our parks and cemeteries, wherein as a rule mere apologies take the place of what should constitute important features in their design and management. One of the first thoughts in connection with the park and cemetery should be that of providing for the comfort of visitors and owners, and while the necessity does not present itself so forcefully in small areas, where the office or lodge can be made to serve the purpose, in larger tracts ample provisions for toilet necessities should be considered absolutely necessary, and the public esteem of the place will be enhanced to no inconsiderable degree by such provision.

IT is a matter of frequent comment that a great improvement is taking place in the artistic value of the memorials being placed in our cemeteries. This was to be expected as a natural sequence to the prosecution of the modern ideas of cemetery management. The fact is the beauties now being unfolded to the lot owners of many of

our cemeteries, improve the mind and bring it into accord with higher conditions. This creates a more refined taste and awakens the dormant love of beauty and order which undoubtedly lies ready for the awakening in every human soul. The old ideas connected with the cemetery pass away, and it becomes a pride and a pleasure to help contribute to the beauty of a place wherein an undying interest must, under healthy moral conditions, continue. Assuming that there is a suggestiveness in such views, what has been so often argued in these columns finds further emphasis,—the necessity of bringing the lot owner to a perfect understanding of and acquaintance with all that pertains to the cemetery, and fostering an enthusiasm for higher forms of improvement toward which human nature, properly directed, naturally turns.

THE suggestion of the Council Committee of Philadelphia, appointed to visit the small parks, that a forester should be employed, one that is educated in the care and knowledge of trees, brings to mind the attention given by foreign governments to this subject, and the efforts being made by our own of the same general tendency. With the commercial spirit so rampant among us, it is the work of years to sufficiently concentrate public thought on any subject, however important it may be, that conflicts with trade interests, until a danger line is reached and a halt is imperative. So it is, that much of our vast domain having been denuded of its forest growth for commercial purposes, such changes in natural conditions have resulted, that a department of our government has been at work for some time examining into this very serious question, and the time is rapidly approaching, when the subject must be taken up as a leading question by the states interested.

THERE is nothing more surprising in the rapid development of the times than the breadth to which educational ideas and necessities have extended. There would appear to be scarcely a branch of any profession or trade, that has not been deemed worthy of more extended research and knowledge, and which has not occupied the attention of the appropriate school or college. Take for instance the old time gardener, and see how as his work enlarged, its necessities required more refinement and knowledge and the landscape man became necessary. And to meet the increased and ever increasing knowledge required to prosecute the



trade and profession successfully, and to the advantage of man of to-day, special courses of instruction have been instituted at many of our prominent colleges, and facilities provided for practical work as part of the courses. Then the general government at many points of the country has established agricultural experiment stations, and very many of the states make appropriations for the support of State Agricultural Colleges. But it is becoming apparent that this is not enough to meet the growing demands of the situation, and a National Horticultural School has been suggested in proximity or in connection with, as complete as possible, botanical park. When thinking over such a matter one invariably turns to the Royal Gardens of Kew, England, which have been the means of disseminating so much knowledge and doing so much good to all the world. Its system of dispensing knowledge affords opportunities to so many, and being always free to the public and a favorite resort, it is in its way a public benefaction, and the men it has given to the world have added to its renown. The nearest approach to anything of the kind in this country is the Missouri Botanical Garden, at St. Louis, Mo., which was practically bequeathed to the public, with wise regulations as to its conduct and ample means for its support. In educational work it is proving a splendid success, and Mr. Shaw, born in England, undoubtedly was impressed with Kew and its usefulness.

#### County Parks.

Professor Thomas H. Macbride of the State University of Iowa, is an advocate of County Parks for rural communities, and makes some timely comments in a communication to the *Iowa City Republican*, from which the following is taken:

But is there any reason why city people only shall have parks? Would not something like a park be equally useful in the rural communities of Illinois and Iowa? I refer now not to the communities gathered in our towns and villages, but to the people in the country; why should the country people not have parks?

They love recreation; at this time of the year, harvest ended, they specially seek it; why shall they not have places to which to go? It has often occurred to me that our supervisors should be empowered, by special legislative action if need be, to purchase, care for and devote to public use, in every county in Iowa, certain areas large enough for popular enjoyment. These areas we may term county parks. There may be in each county one or several as circumstances may suggest. Details as to control, management, etc., may be subject of later discussion, but just now the absolute-

ly crying need of some such provision for public outing and amusement is everywhere patent. The public health demands it; the people ought to have it; the only question is how shall the demand be met?

Fortunately in many regions Nature comes to our assistance. Throughout the eastern tier of counties there is hardly one in which may not be found one or more wooded, often rocky, romantic places exactly suited to the purpose I suggest.

I fancy that in fully one-half of the counties in Iowa there are localities, where for a comparatively small sum, four or five hundred acres of land could be purchased, suitable to our purpose; and really of little value for anything else, land covered with timber or brush, probably with rocky ravines, a stream of water, possibly springs. Let the county own one or more such parks, care for them, preserve their wildness, their freshness and under suitable restrictions, open to the people these groves and rocks, and all the future will bless the generous wisdom of the men who planned for public happiness and health! The country people need the park just as much as the towns folk and if they ask for it they will get it. Some of the localities to which I have referred and these are types of hundreds of others, are almost parks already. All they need is intelligence, care and devotion to public use. Take for instance the "Backbone" in Delaware county, a long narrow ridge of limestone rock, ninety feet in height washed on three sides by the clear waters of the beautiful Maquoketa, surrounded by a wide forest of native oaks and elms and walnuts, crowned with a grove of native pines, beneath whose shadows rise perennial springs—what more can you wish? Chicago covets her bit of lake sand yonder; for the "Backbone" Chicago would pay a million dollars and would make it cost two million more, all for the pleasure of her people; and yet the good people of Delaware and Buchanan counties have not yet found a way to preserve for themselves and their children this lovely natural park. A large land-owner in Delaware county has stretched barbed wire around twelve hundred acres of fairest natural scenery and uses it—as a cow pasture! And yet every year by hundreds the people show their needs, their want, by visiting the "Backbone," camping at its base willing to enter a cow pasture if only they can get a taste of spring water and for a few days rest under the elms and breathe the balmy odor of the pines! If the county cannot act, is there no philanthropist who will, whose means enable him to say—I can.

I believe in the people and their cause, I plead, not for the present only but for all time to come.



In prairie sections there may be counties where every tree must be planted. In such counties parks will be more expensive, but such is their necessity that it seems to me only a question of time until the people will own such parks, whatever the cost. The sooner we begin to build, the sooner shall we enjoy. But in a vast number of cases all that is needed is such ownership as shall save from private spoliation, and such restrictions as to use, fires and the like, as shall transmit to those who come after us the natural beauty and restfulness of our land.

#### Lily Ponds at Lincoln Park, Chicago.

The present very general use of aquatics in Parks in the West followed their adoption in Lincoln Park in '89, and their introduction there must be credited to the persistent efforts of Mr. J. A. Pettigrew then Superintendent of the Park and now of the Parks of Milwaukee.

Previous to that time Mr. W. H. Chadwick, the President of the Chicago Horticultural Society, grew *Zanzibariensis*, and perhaps some other choice tender varieties of *Nymphæas*, in a small pond in his garden on Belmont and Evanston avenues, Lake View, Chicago, and Mr. Pettigrew had himself grown two plants of *Victoria Regia* in '82, in wash-tubs till the leaves were eighteen or twenty inches in diameter. They were raised from seed procured from the Curator of the Birmingham, England Botanic garden with a view of interesting Sec. Reynolds of the Exposition Company in them. And, in fact, he promised to build a tank for them in the conservatory annex of the old Exposition Building, but let the matter run on until too late, probably being doubtful of the success of the feature, and as Mr. Pettigrew says, "how could I persuade him of their glorious beauty?"

In the introduction of tender aquatics in the Park there were similar doubts to be dispelled, and it required strenuous efforts to secure an appropriation for purchasing the plants and providing suitable quarters for them. The money was, however, finally forthcoming and a low swale among the sand dunes was selected. The spot was well adapted for the purpose and being near the engine house,

steam for heating the water was easily supplied.

The plants met with various misfortunes and for a time the result was doubtful. Indeed the ponds were facetiously referred to at this stage as "Pettigrew's frog ponds." But the plants finally redeemed themselves and beginning about July 12, the flowering of the *Victoria* was for some time announced in the evening papers and hundreds visited the Park to see the flowers by electric light. And by the middle of August the *Nymphæas* also attracted crowds of visitors.

But, while tender aquatics are charming, (and they are nowhere grown more successfully than they are to this day in Lincoln Park, Mr. Stromback, the well known Park gardener, being a painstaking expert who recognizes no such word as fail,) still



LILY POND, LINCOLN PARK.

the ponds of hardy water plants are really more attractive as a landscape picture and the flowers themselves are a dream of beauty.

The ponds are larger than those that are warmed; their setting is naturalistic, and the planting along the shore adds much to the good effect. The stone bridge that spans the twenty-foot channel connecting the two ponds is a picturesque feature that is justly admired. It is thirty eight feet long, ten feet wide overall, and from the water to the top of the battlement is seven and one half feet. It is built of boulders and limestone, and it, together with the limestone stairs at the right, at the top of which the little girl stands to watch the camerist taking the photograph, was built by ordinary Park laborers at slight expense.



Wild grape vines find crevices of support in the inequalities of the undressed stone of the bridge and by its aid fling themselves across the water. At present they are pleasing, but if the vines are allowed to further veil the stone work the bridge will lose that appearance of stability without which architecture is distinctly inconsistent.

The shore planting is good, as may be seen by the cut.

The group of plants at the left of the bridge, just back of the two workmen in the water, are the hardy grass *Eulalia Japonica*, wild Iris, and the clump that rises back of and above the others, is *Ligustrum vulgare*, or common Privet, which is among shrubs what Virginia creeper is among vines, and is said to have made more barren spots beautiful than any other shrub. This is because it makes itself attractive in spite of poor soil, unpromising situation and neglect. In fact it seems to be a real friend in need.

The group nearest to and in front of the bridge and stairway on the right occupies considerably more space than it seems to, and is composed of moisture-loving shrubs, small trees and herbaceous plants, some of the latter being strictly bog plants.

The small umbrella-shaped tree is *Ptelia trifoliata* or Hop tree. The leafy plant to the left of it near the bridge is a thrifty specimen of *Hibiscus Californicus* that gives a good crop of exquisitely pure rose pink flowers in late summer every year. Another leafy plant near the *Hibiscus* is *Helianthus gr. serratus*, and the last leafy plant to the right in the same distant group is *Aralia Spinosa* or Hercules' Club, a tropical looking plant with spiny stems.

Interspersed among this group near the water's edge is the giant reed *Phragmites communis*, and the pond is fringed just here with wild Arrow head, *Sagittaria variabilis*, growing in the margin of the water.

On the shore to the right of the distant group, and in the middle distance, is a clump of *Cornus siberica*, next to this is *Rosa rugosa* and the nearest group on the extreme right at the water's edge is *Cornus sericea* or silky Cornel, a purple twigged Dogwood that is a strong grower and a very valuable shrub in landscape work.

Any good catalogue of hardy aquatics will furnish a list of those grown in these ponds, for all are there from the miniature white stars of the Japanese water lily, *Nymphaea pygmea*, to the great Egyptian Lotus, *Nelumbium speciosum*, proudly holding aloft its classic, cup shaped, rose tinged blossoms—the Queen of hardy aquatics.

The two men, clad in waterproof garments, are clearing the ponds of that obnoxious water weed

*Limnanthemum Nymphoides*, formerly called *Villarsia* and popularly known as Floating Heart. In some catalogues it is erroneously named *Limnocharis Nymphæfolia*; but *Limnocharis*, or Water Poppy belongs to the Water Plantain order, while this objectionable weed is a member of the otherwise very respectable Gentian family. It is a pest and should not be included in any list of aquatics, for amateurs are frequently misled into ordering it. Its introduction into a happy water family is certain to cause endless trouble, and it is much easier to get it there than to get rid of it.

The water in the hardy ponds is about thirty inches deep, and the plants are in boxes one foot deep that vary in size from six feet square to big ones 10x16 feet used for Lotuses.

The boxes of plants are left in position in winter, but an inlet at the upper end and an outlet at the lower end of the ponds keeps the water constantly in motion so that it never freezes at the bottom.

Pioneers are usually from the hardy classes and it seems a little strange to find the reverse true in the use of aquatics in Parks. The tender section led the way, broke the ice, as it were, for the hardy varieties.

Both, however, are so beautiful, do so much to give pleasing variety, and prove such an attraction in Parks, that, having been once used are thereafter found indispensable. *Fanny Copley Seavey.*

Why not so conduct our cemeteries that, at least, after the generation that has a personal interest in the grave has passed away, that grave may be used for other interments, or better still, why not apply science to this matter so that the process of decay may be hastened, that as rapidly as possible the bodies interred in our cemeteries shall be resolved again into the earth, and that in the time when cemeteries shall have been abandoned and cremation shall have been adopted as the proper and scientific mode of disposing of the body, our cemeteries shall have become beautiful parks, dedicated to the memory of the dead. Now it seems to me that instead of seeking to prolong this process of decay by the adoption of leaden caskets, marble boxes and hermetically sealed vaults, we should seek to promote it by every means known to science. So far as sentiment is concerned, I at least find nothing dreadful in that thought, that the body of one that I have loved has been resolved again into the elements of life, and gone to nourish the things that purify the air and gladden the eye. There is nothing dreadful in that all, but that other thought that the form once dear to me lies for years, rotting in the ground, a slowly wasting, hideous mass of putrefaction, and that the ingenuity of man has been employed to prolong this terrible process, that thought is horrible.—*J. S. Norton.*



**Tropical House, Fairmount Park, Philadelphia.**

Horticultural Hall, Fairmount Park, Philadelphia, is a great attraction to visitors, especially in the winter season, the fame of its large sized tropical plants being almost world-wide. Our illustration shows but a portion of the hall, and some of the finest plants are, consequently, not represented. There is to be seen a gigantic specimen of bamboo, *Bambusa striata*. It consists of a clump of about 12 stalks, the stoutest not over 3 inches in diameter, yet these canes have reached the roof, some 60 feet high. Some sprays of this plant are represented in the illustration on the left hand side of the roof. It is a Chinese plant and should be almost hardy here. There are near it some fine specimens of a palm from Southern China, *Livistona Chinensis*, better known as *Latania Borbonica*. One is 20 feet high, as many wide, with a trunk 2 ft in diameter. Immense racemes of berries hang on them. These



PALM HOUSE, FAIRMOUNT PARK.

racemes are three feet in length, and contain perhaps a thousand seeds. A small plant of it is seen on the right hand side of the picture, with a specimen of the India rubber plant immediately in its front. A curious coniferous plant, *Dammara Australis*, the "Kauri Pine" of Australia, though reaching to the top of the building, has a spread of about 6 ft. There are some very large plants of *Araucarias*, *Cunninghamia*, *Excelsa* and *Bidwilli*. These are 50 feet high. The former is hardy in the south of England. It is from Australia. An old acquaintance, *Seaforthia elegans*, is represented by several specimens, some of them 25 to 30 feet high, with trunks 15 inches in diameter. These trees bear fruit freely, and lots of seedlings are to be seen springing up about the parent plants. This is known as the Illawarra palm of Queensland.

*Ravenala Madagascariensis* is the traveller's tree. It is of banana-like appearance. The rain gathers

in its cup-like leaves affording relief to the weary traveler. A specimen here is 25 feet high, and many of the leaves with stalks, are 20 feet in length. There is a sago palm, *Cycas revoluta* 6 feet high, and of another species, *circinalis*, there is one 12 feet.

In addition to these there are more or less fine specimens of such plants as *Monstera deliciosa*, *As-trapaea*, *Wallichii*, *Alsophila Australis*, *Persea gratissima*, the alligator pear of the West Indies. *Camphora officinales*, Camphor plant, *Cocas nucifera*, Coconut palm, *Coffea Arabica* producing ripe seed. *Chamaedoria graminifolia*, *Eugenia jambos*, *Phœnix dactilifera* and many other tropical and useful plants.

The main hall in which these plants are is solely for this class of plants; and the scene as one enters the door is thoroughly a tropical one. Something like this is wanted in all parks. The public ask for something of this kind for winter. The outside trees and flowers suffice in summer. What a treat it is to the people of a city to have a large hall like this one for visiting in winter is shown by the great numbers who visit the one at Fairmount.

*Joseph Meehan.*

INFLUENCE OF CLIMATE ON FOLIAGE.—Professor Strasburger is one of those eminent European botanists to whom students in plant life have looked up to as among their greatest teachers, and it is therefore with some surprise that Americans read a recent paper of his in connection with the influence of climate on the structure of leaves. He takes, for an illustration, the European Beech. He says that when the beech produces its leaves in the deep shade of the forest, they are larger and finer than the leaves of the same tree exposed to full sunlight, and from this he deduces a general principle that abundance of sunlight to a dry atmosphere is the reason why leaves are thick and small. Yet it has been for over a quarter of a century placed on record, and admitted as an undeniable fact, that in the case of allied species of European and American trees, the leaves of the American are larger and thinner than the leaves of the European. The American Linden has larger and thinner leaves than the European Linden. So has the American Sweet Chestnut, American Oak, American Ash, American Buttonwood or Sycamore, and in fact, all American trees that have close European allies. And yet no one will contend for a moment that the English climate is dryer, or that there is more light or more long continued sunlight in England than America. It is unfortunate when great authorities like Strasburger attempt to found great scientific truths on such slender materials.—*Meehans' Monthly for September.*



### The Monumental Cemetery of Milan.

It is only something over eighty years ago that a writer drew attention to the dilapidated condition of the cemeteries of Milan. Words could hardly describe the wretched and lugubrious pass to which cemetery matters had come, if the language of this writer is to be relied on. Utter carelessness and disregard of the commonest decencies attending the care and disposition of the dead seemed to rule society.

Then a reaction set in and from the one extreme of poverty, popular sentiment clamored for the other of ostentatious monumental display, regardless of all proper associations connected with the cemetery and its object. For a number of years the discussion of the cemetery project was carried on, but the first real work in the matter dates from 1837, and from that year until 1863 the time was occupied in discussion and debate between opposing factions. During the period many designs were submitted and examined, sites selected, questions of public health considered and the whole question overhauled throughout.

Finally, on November 2, 1866, the religious dedication took place and the Monumental Cemetery waited its future.

The illustration of the entrance to this cemetery, shows a modified Byzantine in style and it is constructed of native stone of various colors, the whole structure costing some \$600,000. In the centre is the "Famedio," it might be called Pantheon, in which grand mass is held once a year for the souls of the departed. The area of the buildings about the entrance amounts to 5000 square metres. In plan the entrance extends across the entire width of the grounds, and on one side returns for a considerable distance. The several buildings included are connected by colonades, and the monumental idea is

carried out in all particulars to a degree which must be seen to be appreciated.

About the central building are grouped the offices and other accommodations.

In front of each corner of the entrance, in recesses formed by the plan, so as to be distinctly separated from the cemetery interior, is the area devoted to Non-Catholics on the left and to the Jews on the right, with their appropriate buildings.

In various niches in the interior and about the colonnades connected with these buildings are placed many fine examples of mortuary statuary and monumental work. Here is also to be found the Columbarium, proper, besides systematically arranged depositories for the ashes of the departed.

The cemetery, comprising some 50 acres, is arranged on a plan not by any means conducive to harmonious effect. For instance, certain contiguous sections are devoted to perpetual burial, and are consequently crowded with statuary and memorials, as will be seen by the illustration. All idea of the sanctity of the cemetery is destroyed by this grand array of the sculptor's art, and as no two monuments are allowed to be erected on the same design, while originality will be a constant attraction, after all it is the display of sculpture which will always be the loadstone to draw the visitor.

Another section is devoted to ten year burial; another to twenty year burial and another to thirty year burial. In the latter section no monument is allowed over about two feet in height and a monotony is the result hard to describe, notwithstanding the rule against duplicating. At the expiration of the limit of time burial the remains are collected and deposited in the Ossario.

About 2000 feet from the entrance gates and at the rear of the cemetery stands the crematorium, the



ENTRANCE TO MONUMENTAL CEMETERY, MILAN, ITALY.





VIEW IN MONUMENTAL CEMETERY, MILAN.

gift to the city of Milan of Alberto Keller in 1867. This was ahead of the times and his own cremation had to be postponed. He may be conceded to have been one of the first to help the cause of cremation by adequate means. This building is classic in design, and has the appearance of quiet elegance, which with many additions to the decoration in the way of pedestals and urns, and its surrounding garden plots containing numerous memorials of the same general character, makes its purpose unmistakable.

At a little over half the distance from the entrance gates to the crematory stands a building called the "Ossario," of a style of architecture to harmonize with the general scheme, which has large subterranean vaults and crypts for the deposit of the bones of the departed, and which also contains spaces for inscriptions of deceased from other cemeteries.

The cemetery, which is quite level, is as is usual in some foreign cemeteries, enclosed by a high wall which renders its seclusion positive. In general it is laid out in the Italian garden style, rectangular with an occasional circle. A main avenue passes from the entrance through the Ossario to the crematory at the extreme end. Between the "Ossario" and the crematory is a portion which in relation to the other part is laid out on a diamond plan, and this part bears the title of the Necropolis. This section of the cemetery is remarkable for its mausoleums,

and such architectural memorials, which in number and variety afford an excellent field for studies in design and arrangement.

It would be impossible in a limited way to describe in detail the statuary which in profusion memorializes the dead in the Monumental Cemetery of Milan. The greatest sculptors of Italy have contributed to the display, and they have had, moreover, some of Italy's greatest sons for whom to create memorials. As was previously mentioned no duplicates are permitted and sketches and photographs are prohibited under penalty, so that the illustrations will show how great must be the variety in design and what latitude has been allowed the artist. Some of the work is *par excellence* great, and attracts attention. Mortuary statuary in Italy has a spirit of its own. The national characteristic temperament infuses into the Italian sculptor's work a spirit not to be met with in other cemeteries.

Returning to the Crematory, which externally is a beautiful structure, in its interior arrangements it is bare and comfortless to a great degree, but this condition of contrast in the Latin countries is frequently met with in other than cemetery matters. The waiting room is cell-like with a few chairs standing round for mourners, who may be of all creeds or classes. At the end of this room is the furnace. In another room are vases for the recep-

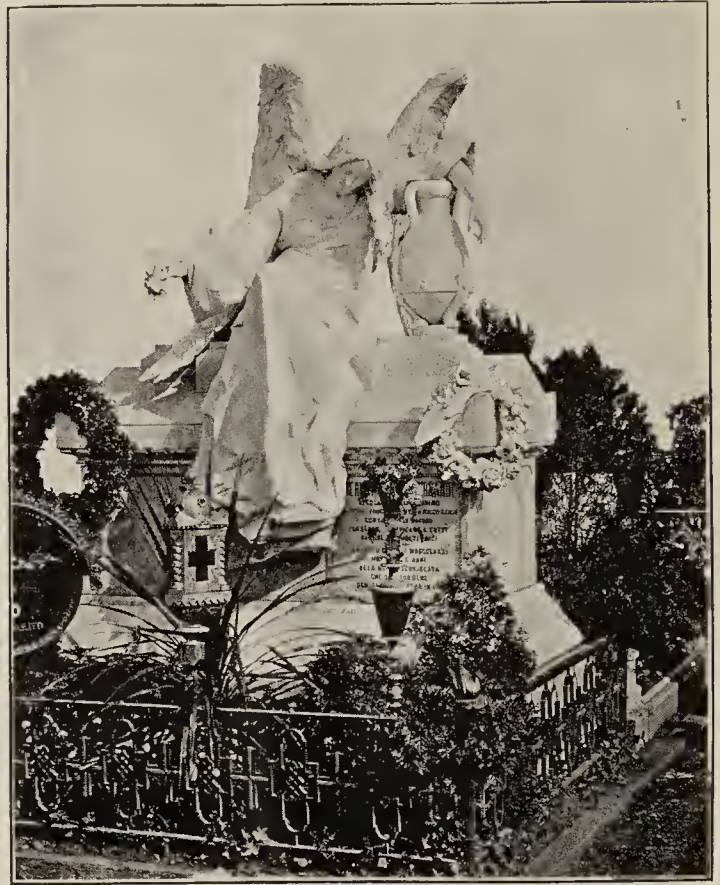


tion of the ashes, while in still another are the little wooden boxes for ashes, of the pauper dead. Cremation of the poor is not compulsory, but it is carried out if requested, and without charge.

There are two systems used, one is that of Paolo Garini which takes two hours to complete and which costs including a mural tablet about \$19.00. The other method is the Varini gas process, by which the corpse is reduced in something like 45 minutes and for which a charge of \$10 is made. A sepulchre for the urn in perpetuity costs some \$8.00. Compared with similar charges in our own United States, these figures are astonishingly low, and should serve as an argument in favor of this disposition of the dead, although the Roman Catholic Church expressly forbids it.

Considering its comparatively small area the Monumental Cemetery of Milan contains a fund of interesting material connected with the disposition of the dead and their commemoration.

The increase in the population of Milan has been such that the cemetery question has again come up, and with it what may be the ultimate destiny of the cemetery herein described. This is an interesting matter and is attracting considerable attention on account of its proximity to the city.\*



MONUMENT IN THE MONUMENTAL CEMETERY, MILAN.



FROM A MONUMENT IN MONUMENTAL CEMETERY, MILAN.

\*In the preparation of this article the use of photographs and notes from Mr. E. Bizzozero, of West Quincy, Mass., is hereby acknowledged with thanks.

#### Garden Achitecture.

Notwithstanding all that is being written on Landscape gardening and Park designing, the subject is a growing one, and is attracting, perhaps, more attention than ever before, as the enlightenment of the race progresses. At a recent meeting at Halifax, England, of the Society of Municipal and County Engineers, Mr. Thomas H. Mawson, landscape architect, of Windermere, read a paper on "Garden Architecture," from which the following extracts afford much food for thought, and put new aspects on certain points of the main question:

"The true park must, like most other inventions, rest on the foundation of good planning, worked according to whatever characteristic is to have predominance, whether seclusion or recreation, or an equal combination of both. On level ground it is comparatively easy to shut off the various recreation grounds into proper compartments, the eye never being high enough to obtain a panoramic view, but in dealing with a site with considerably varying levels much would depend upon the disposal of these features. The trampled grass of the cricket crease, the cinder-path of the cycling course, and the excited noise of the foot ballers are disturbing elements which require careful handling; nevertheless, everything which is calculated to induce physical recreation should be included, and receive careful attention. The requirements of the sur-



rounding population would, of course, decide what to go in for, but the following are specially worthy of consideration:—Lake for boating and bathing ponds; children's playground; cycling tracks; football grounds; cricket-creases; bowling greens; archery courts; quoit grounds; gymnasiums for both sexes, tennis lawns.

“In the public park there are so many things upon which the beautiful may be expressed that the eye may be instructed and pleased at every turn. Take, for instance, the boundary fence; why always adopt an unbroken line of unclimbable spiked heads? A cheap fence can be made by introducing wrought-iron panels at intervals and by other devices. Again, wrought-iron or oak entrance gates, of simple design, are more artistic than more elaborate cast-iron ones; a simple brick or stone pier is also preferable to the lamp-post kind of pillar so often met with. The shapes into which the hedges should be cut, and the arrangement of flower-gardens are also worthy of a little extra thought. The band-stand, the ‘temple of music,’ is upon this account worthy of more becoming artistic treatment and better material than is usually bestowed upon it. Then, again, there are the fountains, drinking-fountains, terrace-walls, flower vases, and garden seats, etc., all of which may be so designed ‘that the sight of them may contribute to man’s mental health, power and pleasure.’

“Small gardens and green spaces should invariably be treated in an architectural and formal manner; quietness of style should be their chief characteristic. In small parks of five or ten acres, fountains and architecturally treated ponds may often be worked in with good effect. A wealth of flowers arranged in formal beds is always appreciated in small parks. Lawn-tennis courts and bowling greens, within quaintly clipped hedges, always look well. Colonnades, parterres, avenues of pollarded limes, give grateful shade. All walks should be broad, especially on terraces, never less than 10 feet on a terrace, and promenade walks never less than 20 feet. Shelters and band stands should be specially designed to harmonize with other features in the park; high keeping and primness should always be associated with small parks. As a rule, parks and gardens of 10 to 20 acres should not be cut up by drives, especially if in a district with a large working-class population. Parks of this size are generally expensive luxuries, as they are too small to allow of much space being allotted to recreation, such as children's playgrounds or football grounds, without destroying its quietude; neither can any portion be laid off for pasturage, consequently all the ground requires to be kept up; but where cost of keeping up is not taken as a very serious

matter, and if the neighborhood be favorable to plant life, it is a size which lends itself to variety of treatment. It is large enough to accommodate all sorts of good gardening, including fine terraces and parterres, rose bowers and gardens, gardens for American plants, and rock gardens for Alpines, ponds for aquatics, shady borders for ferns and lily of the valley. There is also space for fanciful alleys and colonnades, and for avenues, for bowling greens and lawn tennis creases. In such a park a large conservatory or winter garden would add very much to its attractions. This should be designed so as to accommodate as large a number of persons as possible during the show season. A park chrysanthemum show should be arranged for every park. Fine broad avenues are always appreciated. For this purpose limes, planes, elms, beech or sycamore are the best. The width of an avenue should never be less than 45 feet, and trees should never be planted closer than 35 feet apart. Avenues should always be straight. In very large parks and on level ground a very pleasing effect may be made by planting three rows of trees to either side, the first thorn; the second, wild cherry; the third, planes or sycamores. For terrace slopes, a batter to meet a step with 6-inch rise and a 14-inch tread is a very good one. Steep slopes burn very quickly; formal lines should never merge into natural slopes, a definite break of some kind should always be made between the two.

“Most of the foregoing suggestions have been urged time and again by the writer when dealing with park committees and corporations, but in reply it has very generally been stated that the views here expressed show too great a confidence in the art perception and good feeling of those who generally patronize public parks, such replies being very often backed up by numerous instances of destruction, especially of verges and lawns, and in other cases of trees and flowers. So firmly have some committees been impressed with this idea that it has led to all sorts of bad arrangements in parks with which the writer has had to do. At Wolverhampton, for instance, a walk is to follow the margin of the lake, because of a fear lest any turf or plantations which ran down to the water's edge should be destroyed. After considerable study of the subject, the writer has come to the conclusion that the public value most things in proportion to the amount of earnest work put into them by the designer and craftsmen working under him. Where destruction takes place it is very often, “though not, of course, always” because the thing destroyed had little right to exist, or otherwise because the planning was so bad that destruction was but the natural consequence.





THE CEMETERY SUPERINTENDENTS AT HOLLYWOOD CEMETERY, RICHMOND, VA. SUP'T. HOOPERS RESIDENCE IN THE BACK GROUND.—Photo by Campbell & Co., Richmond, Va.

#### Convention Notes.

Some of the pleasantest features of the annual convention of the cemetery superintendents are the afternoon outings. The morning hours are devoted to the reading and discussion of papers, but in the afternoons object lessons are sought in the parks and cemeteries in and around the city, and these out of door sessions, if they may be so called, are always helpful to the close observer. Here numerous comparisons are made, reasons for doing things thus and so are brought out, defects are profitably criticized and even though the places visited may be far from modern their very shortcomings serve to point the way how not to do certain things. Grass, shrubs and trees and every thing else that is interesting comes in for its share of attention in the most practical way.

\* \* \*

Superintendent Hooper's admirably arranged program enabled the visitors to see to the best advantage all of the parks and cemeteries of Richmond excepting two. A threatening cloud having made it necessary to forego the visit to Mount Calvary and Riverview. The former, a new burial place for the Catholics, is said to be handsomely situated for fine landscape effects. Richmond is the center of a most historic region. Within a radius of one hundred miles Anglo-American civilization was founded on this continent, the political and military history

of the Revolution was practically begun and ended; and here were the decisive contests of the war. In the numerous parks, whose total area is about one tenth that of the entire city, are to be seen many fine specimens of monumental art commemorative of brave men of olden and recent times. Crawford's famous Washington equestrian statue, and Mercie's equestrian statue of Lee are monuments of which any city in the world might well be proud.

\* \* \*

The drive on the first afternoon of the convention gave the visitors a glance at many places of interest in the western part of the city. St. John's church within whose walls Patrick Henry gave utterance to his famous speech in the Virginia convention of 1775, and the adjoining graveyard with its ancient tombstones engaged attention for some time. The accommodating keeper Mr. Graffigna repeated many of the old epitaphs which are dated far back into the last century and related much of interest concerning his ancient charge.

\* \* \*

Joaquin Miller once described Richmond "as a wide city built on seven hills," and it is frequently referred to as the city of hills. Forty years ago Thackeray pronounced Richmond "the merriest and most picturesque place in America." The experiences of later years has modified the then existing



conditions as regards merriment but the quality of picturesqueness still remains. Chimborazo Park and Libby Hill command views of the James River and the rolling country on either banks. On Libby Hill stands a towering column of Petersburg granite nearly 100 feet in height surmounted by a bronze statue of a confederate infantry man 16 feet high. The column is modelled after Pompeys Pillar in Alexandria and was erected as a memorial to the Confederate Soldiers and Sailors. Oakwoods Cemetery is in this part of the city. It comprises about 100 acres of level land and is controlled by the city. 16,000 confederate soldiers are buried here. A simple granite shaft has been erected to their memory. Supt. Dickinson escorted his visitors around the grounds. The high grave mounds and lot inclosures showed that the new order of things in cemetery maintenance had not yet taken root here. Improvement however is the order of the day in Richmond and we may look for some reforms in the cemeteries. The days sight-seeing ended with a visit to the "Old Stone House," built before the middle of the last century. It is said to have been used as Washington's headquarters during the Revolution and is a quaint old structure filled with relics.

On the following afternoon the residence districts, parks and drives in the western part of the city were visited; a pleasant stop was made at the Confederate Soldiers Home where many veterans of the grey are passing their closing days. An hour or more was passed in Hollywood where lie buried Presidents Monroe and Taylor, Jefferson Davis and many confederate army officers, politicians and others known to fame. A covered iron enclosure of gothic design covers the resting place of Monroe, but that of Tyler is unmarked. Hollywood takes its name from the beautiful holly-trees that are so numerous throughout the grounds. It was laid out in 1849 after plans prepared by Mr. John Nottman the Philadelphia architect. Hollywood comprises nearly 100 acres of hill and vale with a great variety of natural trees. For beauty of situation few cemeteries can compare with Hollywood. It overlooks the James River and from Presidents Hill a view is had that sweeps the surrounding country for miles around. One cannot but regret that modern ideas do not prevail in regulating the character of lot improvements. High grave mounds, granite coping and high grave stones should not be permitted in a spot where nature has so lavishly provided for undulating lawns, natural wooded hill-



ENTRANCE TO HOLLYWOOD CEMETERY, RICHMOND, VA.



sides and everything that goes to make an ideal burial place. In the new sections now being added such restrictions should be enforced. In the confederate section of the cemetery or that contracted by the Ladies Hollywood Memorial Association is the soldiers monument to be seen in our illustration. The pyramid is 45 feet at the base and 90 feet high. It is built of random courses of native granite, and is partially covered with hardy vines.

Before taking leave of Hollywood the party was grouped on the lawn near the cemetery office and a photograph taken, which is illustrated in this issue.

---

**To the Members of the A. A. C. S., at Richmond, Va.**

I cannot refrain from writing a few words with reference to your visit to our city,—indeed I am not capable of expressing myself as I would love to do.

The poor manner in which I received and entertained you while in our city, did not deserve in the slightest degree any special recognition from you. We had not the sights to show you that compared favorably with places previously visited by you, neither were we able to entertain you as you have been heretofore, and as we desired to, but we simply did the *best we could*.

The many kind expressions made personally to me on every hand, as well as the eloquent speech made by Mr. Simonds in presenting the beautiful and elegant present were beyond my comprehension and was such a surprise to me, that I was completely dazed; I know not what I said when I tried to respond, I could not possibly have done justice to my feelings, I was so overcome and entirely surprised that unlike Brother Simonds, "Locomotive," I could not find a "Safety Valve" through which I might express my feelings.

The object of this letter is to thank you one and all as best I can, and while I know you were too abundant in your expressions, it will be pleasant to my dying day to remember the kind and friendly words of encouragement spoken by you.

I accept your presents not for their intrinsic worth (though they are both handsome and elegant) but for the feelings which prompted you in giving them. I shall often sit at ease in my *chair* and by the sombre light of the *lamp* read, and think of my friends and their visit to Richmond, and what joys we had together and how sad I felt at having to part with them.

Again and again I thank you and trust we may all meet at many more conventions. Of the ladies I would say all praise is due for their attendance, their presence always adds dignity to the occasion, and inspires us of the sterner sex to have purer thoughts, loftier motives and by their sweet faces,

gentle manners and kind words train our hearts into such directions as lead us nearer to God and Heaven.

JNO. R. HOOPER.

---

The testimonial above mentioned consisted of a handsome quartered oak rocking chair and a parlor lamp and stand, the latter of solid brass with onyx top.

---

I have never been able to understand how a cemetery could be made beautiful by monuments; it seems to me there is nothing so offensive to the taste as graves surmounted by monuments of all sorts, grotesque designs, faulty construction, old and crumbling stones, vague sentiment half wrought out; queer and sickly fancies perpetuated in marble and bronze. Why there is no place where the morbid imagination of man runs riot as it does in a cemetery. You see things there that seem to be parodies upon human sentiment, and yet it is permitted because it is thought that the grief of one who has sustained such a loss is sacred. I do not think it so; I do not think that we are bound to surrender to the fancy of a grief stricken one in all things, any more than we are to humor the sick fancy of an invalid. If they be so morbid, so grotesque, that we feel that we can substitute our calmer and better judgment for theirs, let us do so. Let us seek to control to some extent this expression. I have always supposed that death was the leveler of rank, but in our cemeteries, we see the ostentatious display of wealth, side by side with the humble tribute of poverty. It keeps alive the distinctions which all regret in life; it seems to be the only way in which certain, purse-proud, and ignorant persons can declare their respect, simply by showing a willingness to spend money; and so we find that in many of our cemeteries some of the most elaborate and expensive monuments have been erected by persons of low degree to distinguish the graves of those whom the world would gladly forget.—*J. S. Norton.*

---

B. F. Hatheway, landscape engineer, of Stamford, Conn., is stopping at the Rural Cemetery, Poughkeepsie, N. Y., laying out the ground for a few hundred more family lots. The association is also contemplating plans for water supply. The prevailing drought in that locality has and is demonstrating the desirability of more water for irrigating purposes. The Rural Cemetery contains over 160 acres located  $\frac{1}{2}$  mile south of the City centre between the old Post road and the Hudson; the N. Y. Central & H. R. R. R., passes between the river and the cemetery. Travellers by this R. R., can always catch a glimpse of these grounds when they pass. Mr. Hatheway has been connected professionally for over forty years in the development of these cemetery grounds.



**Taxation of Capital Stock of Cemetery Company.] 71**

The argument was made in the Pennsylvania case of Commonwealth V. Hillside Cemetery Company, recently before the supreme court of that state that where a cemetery company pays a tax upon its real estate, and the value of its capital stock is made up of the value of the real estate, it would be double taxation if it should be held liable to pay a tax on its capital stock for the same year. But the court holds otherwise, especially as the tax on the real estate referred to was a local tax for county and other municipal purposes, while the tax on the capital stock was a state tax.

\* \* \*

**Valuation of Land for Park Purposes.**

Where land is sought to be taken for a park at not too long a time after the first land thereof is secured, the owners of the land to be taken at the later date will be entitled to recover damages for the enhanced value resulting from such scheme for a park if the original scheme did not contemplate the taking of their land for it; but if it did, they will not. So holds the supreme judicial court of Massachusetts in the case of Bowditch V. City of Boston. To illustrate: It appeared in evidence in this case that the city of Boston had in 1891 acquired, for park purposes, the estate adjoining on the north that involved in this action, and that in April, 1892 it took for park purposes all of the estates surrounding a certain pond, except this particular property and two estates immediately adjoining the pond on the north. On one of the estates not taken was an ice house. It also appeared that this land (and, by inference, the remaining estates) was taken in December, 1892, only some seven or eight months after the taking in April of the same year. Upon this evidence, the court holds that it was competent for the jury to find that the scheme or plan, as it existed in April, 1892, contemplated, as a part of it, the taking of this land and of the remaining estates around the pond, and that the rule as above stated was applicable thereto.

\* \* \*

**A New Wisconsin Cemetery Law.**

The Wisconsin legislature at its last session passed the following law: "Section 1. The trustees of cemetery associations are hereby authorized and empowered to enter into contracts with individuals owning or interested in a lot or lots in cemeteries or public burial places for the care of and preservation of said lot or lots and their appurtenances, under such terms and for such compensation as may be agreed upon by the parties to the contract, and such contract may provide that such lot or lots shall be forever thereafter exempt from

all taxes or assessments there after to be levied by such association for any purpose whatever.

Section 2. From and after the time of making said contract it shall be the duty of the board of trustees of said cemetery association to care for said lots as provided for in said contract; which said contract shall be reduced to writing, setting forth what care said association is to take of said lots which shall be forever thereafter exempt from all tax or assessment of every name and nature thereafter made by said cemetery association for any purpose whatever; which said contract duly recorded in the records of the association shall be in a book kept by said association for that purpose."

**PRUNING TREES AT TRANSPLANTING.**—It should not be forgotten that the branches of trees have varying degrees of vital power. Strong, vigorous, healthy branches would endure unfavorable circumstances when the weaker ones would give way. In growing trees, it is always the weaker wood which we find among the dead branches. In transplanting a tree, we want all the branches that are full of life and vigor, and not those that are already half-dead. The practice generally followed, therefore, of shortening back the strong, vigorous branches, and leaving the half-dead ones, is a mistaken course. If all the half-dead branches were cut away, and the stronger ones left without shortening, transplanting would often be more successful than it is.—*Meehan's Monthly for October.*

The world is full of beautiful forms, and every moment, in a thousand places, human figures are falling into plastic and noble attitudes. Meanwhile, to this one art of portrait sculpture, we deny all but the most unlovely convention. Well-to-do people, in their best clothes, are all cut to one pattern, and that the most shapeless and uninteresting that the ingenuity of tailors has devised. We may test the principle in any country village. A young man or a young woman, of healthy constitution and right proportions, busy on a working-day, in working clothes, is a graceful and pleasing object. Sculpture does not disdain to perpetuate the mower in a hay field or the milkmaid beside her cow. They are artistic figures, because easy, natural and appropriate. But we see them on Sunday hampered by the stiffness of their best clothes, and all the charm is gone.—*Edmund Gosse.*

The French government has issued invitations to the nations to appoint representatives in the matter of the Universal Exposition to be held in Paris in the year 1900. National pride will inspire the French people to great things for this event.





Hang her an epitaph upon  
her tomb.

*Shakespeare.*

In Crayford churchyard, Kent, Eng., is found the following over the grave of one Peter Snell:

Here lieth the body of Peter Snell, thirty-five years clerk of the parish. He lived respected as a pious and faithful man, and died on his way to church to assist at a wedding, on the 31st of March, 1711. Aged 70 years. The citizens of Crayford have raised this stone to his cheerful memory and as a tribute to his long and faithful services.

The life of this clerk was just three score and ten,  
Nearly half of which time he had sung out Amen.  
In his youth he was married like other young men,  
But his wife died one day, so he chanted Amen.  
A second he took, she departed. What then?  
He married and buried a third with Amen.  
Thus his joys and his sorrows were treble; but then  
His voice was a deep bass as he sung out Amen.  
On the horn he could blow as well as most men,  
So "his horn was exalted" in blowing Amen;  
But he lost all his wind after three score and ten,  
And here with his wives he waits till again  
The trumpet shall rouse him to sing out Amen.

The following epitaph on a monument near Columbus, Kansas, appears sufficiently curious to merit publication, writes D. M. Jones of that place:

Here lies the honest Hiram Crumm  
His eyes see not, his voice is mum,  
He believed not man-made Gods, nor creeds,  
His life was full of noble deeds.

In St George's Churchyard, Birmingham, to the memory of Jno. Butler, A. D., 1700:

O, cruel death, how could you be so unkind,  
As to take him before and leave me behind?  
You should have taken both of us if either,  
Which would have been more pleasing to the survivor.

Copied from gravestone in New Boston, N. H.

Daughter of  
GEORGE & SARAH  
JONES  
Murdered by  
HENRY N. SARGENT  
Jan. 13, 1854-  
Aet. 17 yrs. & 9 mos.

Thus fell this lovely blooming daughter  
By the revengeful hand a malicious Henry  
When on her way to school he met her,  
And with a six self-cocked pistol shot her.

Upon a lawyer:

"Here lyeth one, believe it if you can  
Who, though an attorney, was an honest man.  
The gates of heaven for him shall open wide,  
But will be shut 'gainst all the tribe beside."

There has been going the rounds of the press an item entitled "A cemetery sold for taxes," in which Mountain Home cemetery, Kalamazoo, Mich., figures as the principal. The item is misleading, the facts being as follows:

Some three years since the city had paved a small strip in front of one end of cemetery, for which the assessment amounts to some forty-five dollars. Since the paving was done the city has caused a certain culvert to be constructed, thereby throwing into the cemetery gutter an amount of water damaging the gutter and embankment in a large sum. The city was asked through the proper committee to remit the tax and the Association would not ask for payment of damages. The city has from time to time (not officially) said it would. When the city advertised sale for delinquent taxes the above tax was included. Section 3 of articles of incorporation shuts off the power of selling etc. and by subsequent legislation the cemetery is forever exempt from tax of any kind, even its securities or otherwise. Of course if the tax is not remitted it will be paid under protest and the city will be sued.

The Chinese, some three years ago, purchased a burial plot in Cypress Hills cemetery, Brooklyn, in which they have temporarily deposited some two hundred celestials. It is oblong in shape, surrounded by an iron bar railing, supported on white marble posts. Everything is neat and clean. The plot is guarded by marble tablets on which are cut particulars of purchase and names of purchasers, the purpose to which the plot is devoted, a number of extracts from Confucius, all in Chinese characters. There are other tablets and at the back of the lot the sacrificial altar. The graves are long, narrow mounds, lying side by side, in rows of from 15 to 20, each marked by a small marble head stone, containing name, age, rank and place of birth of deceased, in Chinese. The headstones are also numbered to prevent mistakes by undertakers. The superstitions of the Chinese carry them into the exercise of curious rites at their funeral ceremonies, exceedingly interesting to students of the manners and customs of different peoples. Every Chinaman expects to be buried in his native country and the result is that the bodies are only left in their Brooklyn resting place for five years, when the bones are collected and cleaned, and after due ceremony forwarded to China for final disposition.

\* \* \*

The Rural Cemetery of St. Johns, N. B., after an existence of some fifty years under the old order of cemetery management is as rapidly as possible being brought into conditions more becoming to modern ideas. An enlightened management and an energetic superintendent, who have spent time and means inspecting many of our advanced Eastern Cemeteries, are to be credited with the rapid progress in improvement now going on. Perpetual and annual care are being introduced, and American rules, adapted to Canadian custom, are creating changes which are evidently meeting with the approval of those interested. Mr. J. R. Ruel, president of the corporation, has added an attractive memorial fountain in memory of his late wife and son. It is the intention to shortly erect a shelter house for visitors, not far from the above fountain, and at a spot which commands fine views of the grounds. It is gratifying to note that these improvements follow right in the line of suggestions frequently urged in these columns, and that Mr. Clayton, the superintendent, recognises their worth as equally valuable for our Canadian neighbors.



PARK NOTES.

The W. C. T. U. of Meriden, Conn., has presented that city with a drinking fountain costing \$1500.

\* \* \*

London has decided to convert into parks and playgrounds for children the 173 disused graveyards in that great city.

\* \* \*

The burned portion of the town of Concord, Mich., resulting from the fire of July 4, has been purchased by a banker of the village to be fitted up for a park.

\* \* \*

Arrangements have been made for the acceptance of the gift of property for a park from Capt. Wm. Hasson, of Oil City, Pa., of which mention was made in a previous number.

\* \* \*

Liverpool, England, has recently been honored by the gift of 108 acres of land at Wavertree, one of its suburbs, for a recreation ground for children. The giver refuses to have his name made known.

\* \* \*

The Board of Park Commissioners of Minneapolis, Minn., has completed its estimates for 1896 for the payment of interest on bonds and the purchase of parks and parkways. The total amount required will be \$134,000.

\* \* \*

The Board of Park Commissioners of Peoria, Ill., awarded the contract for the palm house and conservatory superstructure including all carpenter work and heating, to Thompson, Anderson & Kennedy, of St. Louis, for \$15,200. Plans and specifications are prepared for the park pavilion.

\* \* \*

Since 1875 over \$15,000,000 have been expended for lands and construction of the Boston park and boulevard system. It can fairly be stated that for variety and extent of landscape, design and purpose, beauty and artistic accompaniments, this magnificent system is not surpassed anywhere.

\* \* \*

The Lake Front Park ordinance, based upon arrangements concluded between the city of Chicago and the Illinois Central Railroad Co. has been passed by the council. This appears to give general satisfaction and will help to make Chicago's water front one of the finest in the world.

\* \* \*

The boulevard system of Chicago, which was originally designed to connect the great parks of the three divisions of the city, and so form a continuous circuit of park and parkway is gradually nearing completion. There have been several serious obstacles in the way, but these have at last been overcome, and in a possible two or three years this splendid scheme will have been consummated.

\* \* \*

The Board of Trade of Yonkers, N. Y., in a resolution has endorsed the action of the mayor and common council in reference to public parks, considering them necessary both for the health and recreation of the people, as well as ornaments to the city, and recommended that some part of the wooded water front of Yonkers be included in the scheme, to preserve one of the town's chief beauties.

\* \* \*

The park commissioners of Kansas City, who have been very busy over the problems involved in the extensive park system under arrangement and construction, adopted a resolution providing for the planting of a double row of White Elm trees

on each side of a portion of a certain boulevard. They were to be obtained under contract, each tree to be eighteen inches in circumference and to be planted twenty-five feet apart. The success of this tree in New Haven, Conn., had much to do with the selection.

\* \* \*

Historical Stony Point on the west shore of the Hudson, New York state, the scene of Mad Anthony Wayne's celebrated victory over the British is recommended to the state for acquisition to be converted into a state park. A bill will be drafted for the next legislature. The rocky promontory is most picturesquely situated, commanding extensive scenery, and will from its associations demand popular attention.

\* \* \*

Brockton, Mass., is looking to the inauguration of a park system. In speaking to the subject the *Newport News* says: "There are few subjects more worthy the attention of the government of a live American city than this of providing breathing places for the people. We hope to see it heartily taken up and wise action taken as a result of the step now taken." The park idea, one of the most progressive signs of the times is taking hold of the American people in good earnest.

\* \* \*

Messrs. W. B. and C. T. Plunkett of Adams, Mass., have donated the use of some twenty acres of beautiful forest land to the people of Adams as a park. The land is not given to the town outright, but the owners intend paying all the expenses of its construction and maintenance, and open it to the public. The idea in this is that the park may never be allowed to sink into disrepute by being neglected by city authorities, but may always be kept in an efficient condition for the purpose intended.

\* \* \*

The Burlington, Vt., *Clipper* says that L. C. Houghton, the owner of the Halifax deer park, is enthusiastic over the prospects of his preserve. The herd of deer have increased rapidly, the total number now being upward of 80, between 30 and 40 being fawns. There are five elk, including two young ones. The old elk become very cross, as the breeding season is approaching. The Rocky Mountain goats are also thriving and increasing. There are several other like preserves becoming established in the east, one in which the buffalo is thriving and increasing quite rapidly.

\* \* \*

Nay Aug Park, Scranton, Pa., narrowly escaped damage from fire last month, a considerable area of woodland adjoining being injured. Prompt and efficient action by the fire brigade and volunteers succeeded in subduing the flames at the confines of the park. This has drawn the park authorities attention to the necessity of the utmost care, and enforcement of such regulations, as will prevent the results of carelessness or vandalism in the future; and the suggestion is opportune for all like circumstances. Beautiful forest parks, which are not so generally distributed as might be desired, are more or less subject to destruction by fire, especially during long dry spells and vigilance and foresight are equally necessary to avoid the possibility of calamities of this kind.

\* \* \*

There is every prospect, says the *Oswego Times*, that the International Park at the Thousand Islands, reaching from Ogdensburg to Cape Vincent, and from Prescott to Kingston, will be established. The Canadian and New York state officials have held a conference in which a resolution was passed setting the boundaries of the park, and also recommending that uniform and common laws be drafted to apply to both Canadian and United States waters. The Canadian government is to dedicate and donate several of the largest Canadian islands for public use and health resorts.



## CEMETERY NOTES.

The leaven is surely working. A lot holder of Crompton, R. I., applied to the town council of Warwick to be allowed to deposit a sum of money for the perpetual care and maintenance of his family lot.

\* \* \*

In response to the oft expressed wish of the late rector of Christ church, Richmond, Va., the ladies of the church propose to erect in the churchyard a fountain to be known as the Sutro Memorial Fountain.

\* \* \*

On a tombstone in Landaff Center, N. H., is the following: "Widow Susanna Brownson was born August 31, 1699, and died June 12, 1802, aged 103 years." The interesting feature of this record is that Mrs. Brownson lived in the seventeenth, eighteenth and nineteenth centuries.

\* \* \*

The cemetery association of Buckhorn Corners, Farmington, Mich., must go to law to recover a deed to its burial place. The association has owned the cemetery for 60 years, but the deed was lost without being put on record. The plat is on a farm belonging to three heirs, of which two are willing to give a new deed, the other one objects, hence the suit.

\* \* \*

The city government of Chicopee, Mass., has accepted the gift of a Memorial Gateway for Fairview cemetery, to cost \$3000, given by the late George M. Stearns. Mrs. Stearns has offered to pay additional expenses if plans she has had prepared are accepted. The increasing number of memorials of this class is gratifying, and shows in great measure that it is only necessary to educate the lot owners in current progressive ideas in order to meet with a ready response.

\* \* \*

The Committee on Gardens of the Massachusetts Horticultural Society recently visited Forest Hills cemetery, Boston, and were evidently much interested in their visit. It is the intention of the officials of this cemetery, while managing the property on the lawn or modern plan, to make it also a garden cemetery, to which end great care is taken in the cultivation of flowers and their arrangement and display in bedding and borders. The combination involves both wisdom and taste.

\* \* \*

A report recently made to the New England Cremation society records that seventeen crematories have been established in this country during the past ten years. The number of bodies cremated in each of the ten years is as follows: In 1885, 36; in 1886, 119; in 1887, 125; in 1888, 199; in 1889, 262; in 1890, 362; in 1891, 464; in 1892, 576; in 1893, 677; in 1894, 876. The above shows a steady increase in cremation, and that this method of disposing of our dead is gaining ground year by year in an increasing ratio.

\* \* \*

A strange custom prevails among a certain tribe in the Caucasus, Europe, says *Current Literature*. When a single young man dies, some one who has carried to the grave a marriageable daughter in the course of a year calls upon the bereaved parents and says: "Your son is sure to want a wife. I'll give you my daughter, and you shall deliver to me the marriage portion in return." A friendly offer of this description is never rejected, and the two parties soon come to terms as to the amount of the dowry, which varies according to the advantages possessed by the girl in her lifetime. Cases have been known where the young man's father has given as much

as thirty cows to secure a dead wife for his dead son.

\* \* \*

The new memorial gates of Oak Hill cemetery, Newburyport, Mass., the gift of Mr. John T. Brown, have been accepted by the trustees. Mr. Brown also completed some improvements in connection with the gates to make the gift unique. It consists of two central and two side posts of Rockport granite, the central ones being three feet square and eleven feet high, surmounted by urns. These posts have panels suitably inscribed. The gates, three in number, are of bronze, and the whole gateway is 26 feet wide.

\* \* \*

One of the large cemeteries of London, England, employs a censor of tombstones, etc. All plans and designs for monuments and tombstones pass through his hands, besides the epitaphs and inscriptions proposed to be cut thereon. If remonstrance fails to change an intention objectionable to this officer, he exercises the power vested in him. It has been found from experience, that a great deal of unsuitable and objectionable material and matter have been kept out of the cemetery, although many efforts have been made, such as filled letters, etc., to frustrate the decisions of the cemetery officer.

\* \* \*

There is no place in the limits of Buffalo where one can see so many beautiful birds as can be seen at Forest Lawn cemetery, says an exchange from that city. The delicate little creatures are in many cases so tame, too, that they will permit the stranger to come very close to them. They seem to know that as far as they are concerned the hallowed ground is a safe retreat. No dogs are allowed there and no cruel boys can molest them or interfere with their nests. There is something most pathetic in their apparent appreciation of the sacred nature of the cemetery.

\* \* \*

A suit has been commenced in New York to solve a knotty point in the disposition of cemetery property belonging to a deceased owner. The late Noyes S. Palmer, some time before his death came into possession of one hundred and fifty lots in Cypress Hills cemetery, Brooklyn, covering over four acres of ground, and valued at \$75,000. Before he disposed of this property he died and it is contended that cemetery lots, when the owner dies, are inalienable and the law is appealed to to settle the question whether these lots can be sold. The decision in this suit will be awaited with much impatience.

\* \* \*

As a means of adding to the beauty and interest of St. Mary's cemetery, Rev. Patrick Cuddihy of Milford, Mass., at his own expense, constructed an Irish round tower, the fac-simile of the famous round tower of Glen-da-Lough, Ireland. It is sixteen feet in diameter, with a height of seventy-five feet, and is built of pink granite, upon a huge granite boulder in the cemetery. It tapers gradually to within 16 feet of the top, where it finishes in a conical cap. It will last for ages, and is said to be the first of its kind in this country. Within its shadow is a lake, an acre in extent, and the whole forms a picturesque and attractive spot.

\* \* \*

The widening of Elm street, Lynn, Mass., necessitates taking in some of the Western cemetery and removing the remains. This cemetery is the oldest in the city, and the tombstones therein contain many quaint and interesting inscriptions, many of which time has nearly effaced. The first recorded interment was that of John Bancroft, the eminent historian, in 1637, of whom George Bancroft, the later historian, is a lineal descendant. John Newhall, the first white person born in Lynn, was also buried there. This cemetery was also the resting place of the famous "Moll" Pitcher, who died April 19, 1813.







### The Association of American Cemetery Superintendents.

To the Members of the A. A. C. S.

Under date of Oct. 7, 1895 I mailed each of you a circular which needs no further explanations, only to add that we rely wholly on your success in securing advertisements for our Richmond report. This notice will reach you the latter part of this month and if you have done nothing in the matter when you read this please do so at once.

Yours fraternally,  
FRANK EURICH,  
Sec'y and Treas.

### Publishers' Department.

NOTICE TO SUBSCRIBERS, If this notice is marked with a blue pencil it indicates that your subscription to PARK AND CEMETERY has expired and a renewal of same is solicited.

Park Commissioners and Cemetery trustees are requested to send us copies of their reports.

Photographs and descriptive sketches of interesting features in parks and cemeteries are solicited from our readers.

PARK AND CEMETERY wants the names of every park and cemetery official or employee who would be likely to be interested in this paper. To the many subscribers who have sent in such lists of names, we return our thanks. There are many more that we should hear from.

Subscribers are again reminded that we want brief notes on any feature of park or cemetery work that will be of general interest. PARK AND CEMETERY is the only publication of its class and earnestly solicits the co-operation of subscribers in making it a help to all identified with such work.

"The Forest Tree Manual," by J. O. Barrett, Secretary of the State Forestry Association, Minneapolis, Minn. This pamphlet of 130 pages is as its name implies, a manual of forest trees, and also

includes Shrubs and Forest Zoology. It gives much information on Forestry matters, discussions, laws, and suggestions and describes methods and operations connected with tree planting and culture, which is particularly timely and grows more so. This is the tenth edition of the work and is dated 1894.

"Park Commissioners Report", Springfield, Mass., for 1894. This handsomely gotten up report of the Park Commissioners of Springfield, Mass., deserves particular attention as it unquestionably represents in printed matter and illustrations, the refined ideas that should be associated with park interests. And further, it is classified in such a manner that a fund of information is made readily available. It describes Forest Park, its chief work, in its several details, and then devotes separate chapters to the birds, the Flora, wild and cultured, with classified lists under each head and concludes with ordinances and laws. The half tone illustrations are a beautiful feature, and a map completes this excellent production. It is handsomely bound in cloth and is a valuable addition to park literature.

The managers of Riverside Cemetery, Norristown, Pa., advertise their property by means of a neat, well printed, four page folder. On the face is a map of the cemetery, on the inner pages a short talk on modern cemeteries and perpetual care, and on the back the prices of burial lots, etc. This is a handy and business-like way of scattering information.

On another page will be found an advertisement of the Andorro Nurseries, Chestnut Hill, Philadelphia, Pa., especially devoted to the Oriental Plane Tree. This tree has been extensively used in many of the large cities of Europe, and it has special qualities, which make it desirable for many situations. It makes a splendid avenue tree, and it is clean and thrifty, rapid in growth, and is free from insect troubles. It is growing in favor and has a good record, which should lead to its use extensively where conditions are favorable.

#### The Horticulturist's Rule-Book.

MacMillan & Co., 66 Fifth Avenue, New York, Price 75 cents. Horticultu-

ists Rule-Book is just to hand. This valuable compendium of useful information has been revised and extended for the edition, to exclude as much as possible all the practice and experience of the past two years. A chapter has been added on greenhouse work and heating. Prof. Bailey in his preface to this edition says: "In its completed form, therefore it is hoped that the volume will serve to codify and epitomize the best part of the scattered and disconnected horticultural advice and practices of the time." Those who have cognizance of Prof. Bailey's valuable work at the Experiment Station of Cornell University, will be convinced of the utility of this book.

#### TRADE CATALOGUE RECEIVED.

Mechans Nurseries. Germantown, Pa., Hardy Shrubs, Trees, Grasses, etc., 28th edition. Fred'k W. Kelsey, New York, N. Y., trees, shrubs, bulbs and plants for fall planting.

Bertermann Brothers Florists, Indianapolis, Ind., have issued an interesting booklet, as an advertisement. It is entitled "House Plants, How to Grow, water, transplant," etc.



## Interment Record and Lot Book.

This system is thought to embrace the best features of the most popular forms of burial records now in use and may be adapted to large or small cemeteries. The Interment Record gives all of the necessary information in regard to the deceased, and the Lot Book locates every grave, so that it can be readily found at any time. The books are printed on heavy paper, substantially bound and furnished in different sizes, depending upon the requirements of the cemetery.

R. J. HAIGHT, Pub., 334 Dearborn St., Chicago.



# PARK AND CEMETERY.

FORMERLY THE MODERN CEMETERY.

A Monthly Journal Devoted to Parks and Cemeteries.

R. J. HAIGHT, Publisher,  
334 Dearborn Street, CHICAGO.

Subscription \$1.00 a Year in Advance. Foreign Subscription \$1.52

## CONTENTS.

EDITORIAL.....	145
GRADING.....	146
CEMETERY LAW FOR OKLAHOMA—HOW TO PLANT....	147
*GARDEN PLANTS—THEIR GEOGRAPHY.....	148
PREMATURE BURIAL.....	149
*WALNUT HILLS CEMETERY, BROOKLINE, MASS.....	150
*SCULPTURED MONUMENTS OF PHILADELPHIA.....	152
*A PRETTY CEMETERY IN ENGLAND.....	154
*REFECTORY BUILDING, FRANKLIN PARK, BOSTON HORTICULTURAL EDUCATION, PRACTICE AND THEORY .....	155
TREES.....	157
GUILD OF KEW GARDENERS *AN ITALIAN MONUMENT	158
PARK NOTES.....	159
CEMETERY NOTES.....	160
*CEMETERY ACCOUNTING IV—OBITUARY.....	161
PUBLISHER'S DEPARTMENT.....	162

\*Illustrated.

ON another page will be found the first of a series of articles on plants and flowers, under the title of "Garden Plants—Their Geography" which it is hoped will be of great interest and manifest advantage to readers of PARK AND CEMETERY. The creation of botanical gardens at many points of our broad country will not only have a tendency to increase the general knowledge of plant life by their existence in our midst, but will infuse a desire to know more about them, with a view to utilizing the countless effects which may be realized by their judicious use wherever plants are required for either usefulness or beauty. These articles are not intended to be botanical in anything but the sequences; they are designed to impart a better understanding of the geography, care required and classification of plants and plant life. Mr. James McPherson, the writer, is thoroughly well acquainted with the methods and system pursued at the Royal Gardens of Kew, of which the world is greatly indebted for its advanced position in botanical knowledge and research. This series of articles is the outcome of the suggestions contained in Mr. Simond's address to the members of the Association of American Cemetery Superintendents at the Richmond, Va., convention.

THE appointment by Mayor Strong of New York, of Mr. William A. Stiles, editor of *Garden and Forest*, as one of the new Board of Park Commissioners, should redound to the benefit of the park system of that city and is a step in the right direction—that of appointing for public service, men experienced in the service required. The park system of New York is growing to be of such magnitude and with so many features requiring a high order of management and knowledge, that it becomes absolutely necessary on the part of the appointive power to weigh very carefully the qualifications of the appointees. Mr. Stiles, in sundry interviews rightly states that parks, while being of present use and benefit, necessitate judgment and forethought in their control, as generations to come will also be interested in what is done to day and will judge accordingly. In the work connected with the establishment of the Botanical Park, the highest professional skill and knowledge will be required, and it is quite necessary that the commissioners should be men equal to the duty of directing that skill.

ONE of the most difficult of all the problems connected with statues in public parks and other places is that of selection; and that especially when a statue is offered as a benefaction. This should not be and would not be now, if the decision as to value, appropriateness, availability and site had been in competent hands. The realization of the truth of this is rapidly dawning upon the community. Were the public statuary already placed of a generally worthy character and artistically good, public taste would have been thus far advanced, and possible benefactors could understand more or less positively what would really be acceptable and be a credit to the people they desire to serve as well as to themselves. The absolute necessity of some competent board or committee to pass upon works of art for our public places has made itself most conspicuously apparent in, it may be said, all our large cities, and the prospect of immediate donations of costly works should excite our communities to immediate action, so that our statuary in the future should not make our art gropings of today the laughing stock of future generations. It is a matter of greater importance than is generally understood, for art is educational and elevating, and should receive that refined consideration which it demands and which is its due.



**Grading.\***

No department of our work seems so easily handled, yet in no other one so many errors made as in grading. It is difficult to suggest and impossible to offer set rules or specific principles because everything depends upon existing surroundings and peculiarities. Grading requires a natural conception of these conditions to produce good effects and results. The laying out and grading roads and the shaping of the ground lying between them constitute what we mean by grading. It will therefore be well to consider the various shapes of ground surface and offer a few suggestions. All natural surfaces may be divided into such as are convex, concave and flat, the latter horizontal or an even incline or slope. On level ground it is, of course, comparatively easy to lay out the direction of the roads; we may consult our individual taste and inclination, but when that is established the difficulty begins how the best effects can be produced on the plane or flat surface. Nothing is more tasteless and monotonous than long stretches of level and flat surfaces, such as are the rage nowadays among landscape gardeners. No matter what may be the advantages for a rolling or undulating surface, these men insist on a nice "level," but only produce stiff lines and awkward grades. A dead level is not advisable nor desirable, nor can it be made to look well and natural. To overcome this let the surface be somewhat convex or concave; occasionally introduce an easy depression, using the excavated material to form a gentle eminence or knoll beyond, even if necessary raise or lower the road somewhat to get the effect. When we consider that in this operation the difference in cut and fill is double the depth of ground taken out we secure quite a diversity in surface with comparatively little labor.

On rising or broken ground, where convex and concave surfaces prevail, it is more difficult to select the courses for roads; they should be arranged so as to convey the impressions that are regulated by the shape of the ground and not the ground by them. Often a deep cut or heavy fill may be required to accomplish this, necessitating a considerable amount of labor, but above all a clear conception of the desired result is required. In the alteration of ground surface we must aim to produce unbroken, undulating, long sweeping and easy lines from the edges of the road, and herein lies the difficulty, because it is impossible to mark such lines by means of tape measure or instrument; they can only be conceived by experience. In making prominent eminences or knolls preliminary heights may be given by

stakes for roughing out the desired surface, but the finishing contour, which gives the surface its final and lasting expression, can only be produced under constant watching and observation. Where natural elevations are found with intervening undulations, or when fine slopes are accidentally revealed during the progress of work, they must be preserved, utilized and emphasized.

Burial sections need not and should not assume an arbitrary uniformity in grade, but should assume the character of gentle undulations. Occasionally individual elevations are desirable which will afford special opportunity for giving prominence to large and choice lots.

Grading or the shaping of ground surfaces and laying out roads are closely related to one another, in fact, somewhat depend upon each other; therefore a few words regarding the latter will seem appropriate. Grades for roads must be alternately ascending and descending, always accommodating themselves to the surface of the ground and thereby appearing natural. The margin of that portion of the section forming the edge of the road should be graded in such a manner so as to convey the impression that the turf had merely been removed. Attention has repeatedly been called to this important fact, and it can not be emphasized too much, that those roads whose margins are tangent with the surface of the border produce the finest effects. In establishing longitudinal grades avoid perfectly level stretches and do not allow a rise of more than 1 in 20 if possible, in rare occasions must a steeper grade be employed; the various grades merging from one into another should be connected by easy lines, showing no abrupt angles at high or low points. For transverse grades engineers recommend that the convexity should be at least equal, if not greater, than the longitudinal grade, so as to throw the water into the gutters, thus preventing cutting and gulching of road surface. A road running along a hillside should incline toward the inner edge and the grade made sufficiently wide to admit of a road-gutter to be formed toward the hill. This will catch the water from the hill and carry it to an outlet before it has a chance to get in the road-bed and will generally prevent serious cutting and washing out.

The operation of grading or moving ground is very expensive work; therefore we should employ every precaution against unnecessary outlay, and study well how to economize and save time and labor. In the first place have a plan well developed and digested and carry in your imagination the result to be obtained. It is necessary to be able to see mentally the finished work before operations are begun. Arrange cuts so as to equal the fills as nearly as possible. Where more material is

\* Paper read at the Convention of the Association of American Cemetery Superintendents, Richmond, Va., September, 1895, by Frank Eurich, Secretary.



needed than the cut will yield it should be obtained from as near as possible. Be sure *never* to remove earth from a place that would have to be filled again in the future, nor place material from where it would have to be removed again; place the material once handled where it is wanted and where it is to remain. Handling ground twice or even more times in consequence of poorly planned work or from inexperience is what often makes grading much more expensive than need be under proper conditions. The only exception to this rule admissible is when, during progress of grading, it seems advisable to save good surface soil for covering bare and poorer places. Such soil should be in all cases preserved even if need be by double handling.

Whatever method is employed to move the ground let there be regularity and order, so that no time counts against the improvement in hand. In work of large proportions and on extended scale the greater part of grading is done by plow, scraper and harrow, but to put on the finishing surface handwork alone, guided by an experienced eye, will answer.

#### Cemetery Law For Oklahoma.

There are some features of the cemetery law enacted by the last regular session of the Legislative Assembly of the Territory of Oklahoma which are of general interest. It provides, among other things, that all incorporated towns and secret societies in the Territory may purchase, take title to, and plat lands for cemetery purposes. The amount of land that may be so purchased shall not be less than ten acres, nor more than eighty acres, and shall be without the corporate limits of the town, and shall be inalienable for any purpose, except cemetery purposes. In the case of towns, the trustees are first to enter into an optional contract for the purchase of such lands as they deem necessary and then they are to call an election on the question of purchase. When lots are sold, the proceeds arising therefrom shall be applied, first, to the surveying and platting of the ground and enclosing of the same, and the balance to the payment of the warrants issued to purchase it, and after all warrants are paid, all funds thereafter derived from the sales of lots shall be used to maintain and ornament the cemetery. The trustees shall provide for the surveying, platting, grading, fencing, ornamenting and improving all or a part of such cemetery grounds, as in their judgment shall seem fit and proper; but shall carefully limit the same to the funds available for that purpose, except the platting and enclosing of so much of such ground as shall be necessary to open the cemetery for burial purposes may be done in advance of funds received therefor. The trustees

may limit the number of lots which shall be owned by one person, corporation or association at the same time; may prescribe rules for enclosing, adorning, and erecting monuments and tombstones on cemetery lots, and shall prohibit any division of the use of lots, and any improper adornment thereof; but no religious test shall be made as to the ownership of lots, the burial therein, or the ornamentation of graves or lots. Lots sold to any corporation or association shall be used only for the burial of their members, or members of their families, and all abandoned lots shall revert to the town.

#### How to Plant.

The following which we take from "Letters and Instructions" to the Quincy, Ill., Park and Boulevard Association, by Mr. O. C. Simonds, the landscape architect, is of value:

The ground where planting is to be done should first be thoroughly plowed or trenched to a depth of from one to two feet. The trees and shrubs should be placed at about the same depth that they were before being transplanted. A common fault is to plant too deeply, and this, especially, should be avoided. Before planting, the ends of the roots should be cut off smoothly and the ends of the branches trimmed back just a little. After planting, keep the ground about the trunks open and pulverized for at least two seasons. Where groups are planted, let the whole surface be kept loose and pulverized by cultivation. Avoid putting plants in rows or in geometrical figures.

Hardy herbaceous plants, such as Golden Rods, Native Asters, Perennial Phlox, Iris, Trilliums, Crocuses, Ferns, etc., should be planted freely at the margin of groups of shrubs, but the planting should not make a continuous boundary. It would generally be best to get the shrubs established before putting in the herbaceous plants. Water-loving plants, such as Cat-tails, Arrowheads, Water Lilies, etc., can be used along the margins of water, and in the lake hardy forms of Lilies can be used. It is not advisable to use bedding plants, as they would not harmonize with the character of the park and would add materially to the cost of maintenance. The park should be used as a place of rest and recreation and should help one to get a knowledge of plant-life, especially the native forms which one is apt to see any day and which will be so much more interesting if we know them by sight as we know our friends.

The oldest obelisk in the world is that near Cairo, Egypt, which has a history of nearly 5000 years. It is growing shorter every year, as the annual deposits of the Nile claim it for burial.



## Garden Plants.—Their Geography.

## RANALES.

## THE RANUNCULUS, MAGNOLIA AND NELUMBUM ALLIANCE.

There are 27 tribes, 247 genera and 1,816 species included in this Alliance. Trees, shrubs and herbaceous plants, both terrestrial and aquatic, are among them. They are beautiful in aspect, handsome in their flowers and as perfect in their structure (or as some have it as complicated) as any Alliance in the Vegetable Kingdom. It is possible to select material from the various tribes with which to plant a large garden and have them in flower for any particular month, or during all the months of the summer. Those who are always at home will derive some flowers at all times; those who live in cottages on the mountains or by the seas, will prefer to concentrate their displays for June, July and August. It is useless for these latter to plant Peonias, Chinese Magnolias and other May flowers. They should choose Clematis, American Magnolias, Delphiniums and Nymphaeas, and the superintendents of parks and cemeteries should also endeavor to occupy their ground with plants which bloom at seasons when visitors are a plenty.

I do not propose to trouble anybody with the names of natural orders or tribes. Botanists have a disposition to change them constantly, often for microscopical reasons, and they are at perfect liberty to take the responsibility if they will only keep the Generic nomenclature fairly unmolested. The Genera will be given in the sequence of the *Genera Plantarum* of Bentham and Hooker, and the specific names will be those of Johnson's Dictionary, Nicholson's Dictionary, etc., which will stand until

the great work of the Kew Index is complete, and probably be but little altered.

Anyone almost can afford the \$4 necessary to secure the new Johnson, and then learn all the ordinary man needs to know of modern plant lore.

The *Clematis* are very largely distributed over the sub-tropical and temperate regions of the world.

Very many species have been described which are not good species at all, but merely

varieties differing slightly from each other, as apples, oranges, or any other plants of wide distribution, differ. It is probable that some 70 species will be retained, with innumerable geographical and garden varieties.

There are several types, but the "Travellers Joy" type (best represented by the Japanese paniculata) and hybrid types, first raised by Mr. Jackman of England, are most beautiful. Of these latter Jackmanii purple, Henry, white, and Star of India, or Madame Ed. Andre, dull red, are most distinct. There are a great number of various shades,



ANEMONE JAPONICA, FL. PL.

both double and single, and recently hybrids between these and the Texan *C. coccinea* have been obtained which may be expected to lead to still greater variety both of form and color. The English "Virgin's bower," *C. Vitalba*, has been used to cover graves from time immemorial. Most Clematis are handsome wall, trellis, or pillar plants, but some are herbaceous. The garden forms are hardy to the lake regions at least, but there are sub-tropical or greenhouse species as yet but little known.

*Thalictrum* embraces 70 species, distributed over Europe, Asia, Africa and North and South America. Their flowers remind one a good deal of the "Travellers Joy" Clematis. Their leaves are often finely and beautifully divided, especially in some Asiatic species. They are herbaceous, and often worth a place in cemeteries. Seeds of these and Clematis are often slow to germinate.

*Anemone* is a genus of 85 species quite com-



CLEMATIS JACKMANII.

mon.



monly distributed in all temperate regions, but rare in the tropics. With the exception of the autumn flowering *A. japonica*, they are not seen in American gardens as frequently as they deserve. It is probable that more attention should be given to providing them with half-shady situations. The Pasque-flower, the wood-anemone and *A. hepatica*, are all natives, but not at all improved, or, indeed, often seen in cultivation. Many are grown in the gardens of Europe, both single and double, and are extremely showy and beautiful in the early spring.

*Adonis* has 6 or 8 good species, all Asiatic or European.

*Ranunculus* is a much more widely dispersed and extensive genus having 200 species scattered over the earth. With the exception of the double *R. aconitifolius* and *R. acris*, white, and yellow "Batchelor's buttons," they are rarely seen in perfection. Seedsmen import them, but except for climates like California they vegetate too early and are too tender for the north. They should, however, be valuable planted out in green-houses. The colors of the Asiatic and African kinds are superb and in fact scarcely surpassable by any flowers.

*Caltha* has 9 species in Europe, Asia, America, Australia and New Zealand. *C. palustris* "in green and gold refulgent, towers, a glory o'er the scene" in many parts of the Atlantic states, and is very common in Britain.

*Trollius* has 10 species in Europe, Asia and North America. The double forms are found in nurseries flowering in May, June and again sometimes in August. They are worth growing, preferably in moist situations, but do well in garden soil.

*Heliborus* has some 6 good species in Europe, Central and Eastern Asia. With the exception of *H. viridis* and its varieties, they mostly require the shelter of a frame, as they flower very early.

*Eranthis* has 9 species in Europe and the mountains of Asia. *E. hyemalis* is often regarded as British, but is scarcely a true native; it is one of the earliest yellow spring flowers, and often spreads largely under the partial shade of trees or lawns.

*Nigella* ("love in a mist") has 23 species in Europe and East Asia; they are annuals and useful for carpeting beds of early flowering *Ranales*, such as *Anemone*, etc., which die down soon after flowering.

*Aquilegia* has a great many varieties described, but only some 8 good species, many of them, both single and double, are very beautiful garden flowers in May and June.

*Delphiniums*, "Larkspurs," have 70 species in Asia, Europe, North America and Abyssinia. They are often beautiful blue, white and pink garden plants, in both perennial and annual kinds,

the latter again very useful for carpeting beds past their season of beauty.

*Aconitum*, in 19 species, European, Asiatic and North American, bear the herbaceous Larkspurs some resemblance in aspect and color. Some are yellowish, mostly all are stately beautiful summer flowers, but should never be planted where the roots can be mistaken for edibles. They are virulently poisonous.

*Actea*, in 2 species, is the equally poisonous "Baneberry."

*Xanthorrhiza* is a little native shrub, the "Yellow root."

*Pæonia* has 10 species, European, Asiatic and North American. They are familiar and highly appreciated June flowering shrubs and herbs, beautiful and gorgeous. They have been selected in a great range of color. Small plants take a few years to arrive at a full measure of perfection, and the less they are disturbed when in a favorable place the better.

James MacPherson.

(To be Continued.)

#### Premature Burial.

The Humane Society through its publication, "*Our Dumb Animals*," has for some time been agitating in favor of adopting methods to insure against premature burial. In a recent issue it described what precautions are taken in Munich, to which Dr. Albert M. Blodgett, of Boston, added the following:

This is not only true of Munich, but of many other places in Europe, and is an undoubted advance upon the custom in America.

"There are many signs which indicate death, but the most of these cannot be employed by unskilled persons. There are one or two which are absolutely reliable under all circumstances, and which may be employed by any person however unskilled he may be, and to the accuracy of which no doubt can be attached.

"One indisputable proof of death is obtained by simply keeping the body under observation until the skin begins to show changes of color and the softening of texture which indicate the commencement of decay, so-called mortification.

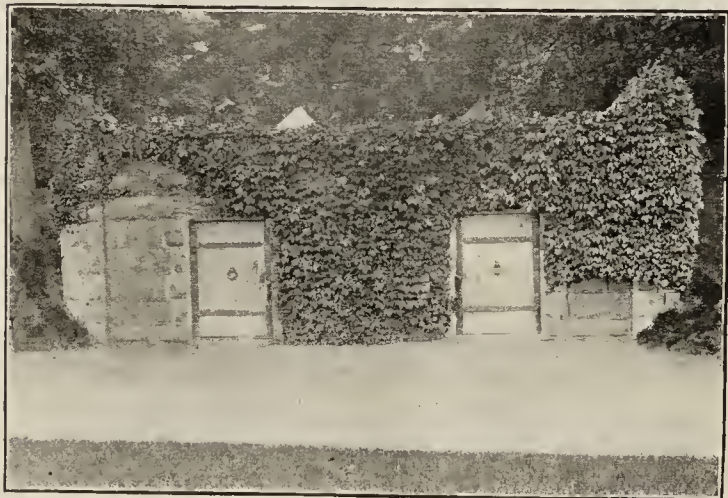
"When this has commenced, there can no longer be the slightest doubt of absolute death. This test is so easy of application and the source of such infinite relief to the friends, that it would seem that the knowledge of it should be more general.

Although Chicago boasts of some two thousand acres of park area, laid out in such a way as to girdle the city, it is sadly in need of small parks interspersed among the crowded districts, a fact which is being at last discussed in quarters likely to create active consideration. The percentage of the disposition of funds for the park system generally is 60 per cent for maintenance and 40 per cent for improvements, out of something over one million dollars income per annum.



**Walnut Hills Cemetery, Brookline, Mass.**

When one thinks of a town like Brookline, Mass., the richest, considering number of inhabitants, in the world, springing in valuation from \$9,000,000 in 1855 to nearly \$60,000,000 the present year, it would seem as if it were the very place



RECEIVING TOMB.

to look for innovations municipal and so it surely is. Aside from many features quite unique in its method of government, it possesses a most remarkable functionary in the Town Clerk, Mr. Benjamin F. Baker, who for upward of forty years has given the world one of the most interesting series of town books, wonderfully written, extant, indeed his perfect system, his inventive, well balanced mind has earned for him the title of "Town Father." It is germane to the subject to speak thus of Mr. Baker for it is to him as much as to any and all others that we are indebted for the Walnut Hills Cemetery, so peculiar in itself and so important as an example of what the burial ground of the future should and must be. It is now twenty-five years since the cemetery was inaugurated and the scheme adopted in its regulation will readily appeal to the ordinary as well as artistic mind and eye.

Right here it is well to insert the rules and regulations concerning lots, tombs, etc., which in several instances will astonish the trustees of cemeteries in general. A board of six trustees, the chairman of the selectmen ex-officio and Mr. Baker as clerk efficiently supervise and carry out the laws which read as follows:

I. No lot shall be enclosed by a wall, fence, coping, hedge or any other boundary whatever; but the limits of each lot shall be marked at each corner by suitable granite posts, and these boundary marks shall be sunk in the ground so that the tops shall be below the surface of the ground. Each lot shall be legibly num-

bered in a manner to be approved by the Trustees.

II. No lot shall be used for any other purpose than as a place of burial for the dead; and no trees within the lot shall be cut down or destroyed without the consent of the Trustees.

III. The proprietors of lots shall not erect any monument, cenotaph, or stone commemorative of the dead without obtaining the approval of such structure by the Board of Trustees at one of their regular meetings, unless such plans shall have been selected from those in possession of and approved by the Board of Trustees, and no flowers, plants, shrubs or trees shall be planted or cultivated in any lot without the approval of the committee on grounds.

IV. The Trustees shall have the right to remove from any lot such trees and shrubs as shall, in their judgment, be detrimental to the adjacent lots of avenues.

V. The Trustees shall have the right to remove from any lot any monument, effigy, cenotaph or other structure, or any inscription, which shall be determined by a majority or the Board to be offensive or improper.

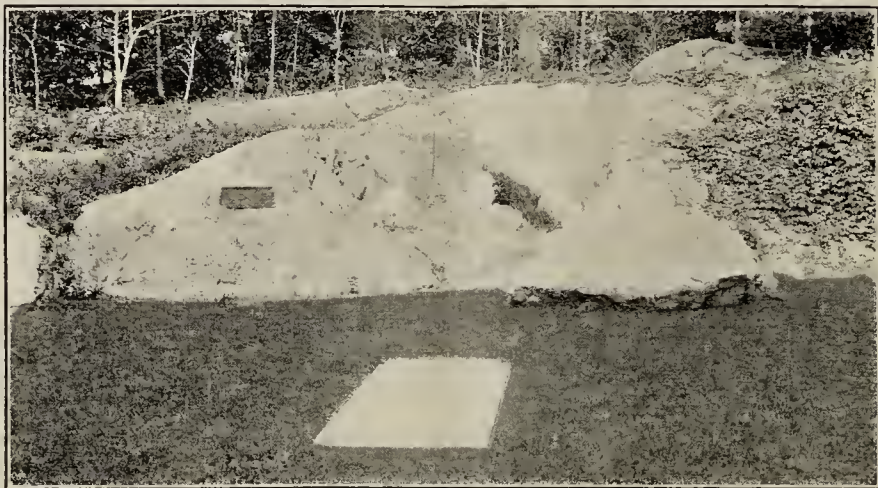
VI. No tomb shall be constructed or allowed within the bounds of the cemetery unless by special permission of the Trustees and only in such places and in such manner as the Trustees shall direct; and no proprietor shall suffer the remains of any person to be deposited within the bounds of his lot for hire.

VII. All lots shall be indivisible.

VIII. All lots when sold shall be trenched, graded, sodded, and prepared by the Superintendent, who shall also provide and set the boundary posts; and all such work shall be paid for by the purchaser in addition to the amount paid for the lot.

Here follows a note which ought to be observed in every cemetery in process of construction.

"No monument or other structure of white mar-



NATURAL ROCK MEMORIAL.



ble shall be erected within the bounds of the Cemetery.

The rules and regulations concerning visitors are as follows:—

I. No vehicle shall be admitted on Sundays unless accompanied by a proprietor of a lot or a member of his or her household with his or her ticket.

II. No horse or other animal shall be allowed in any part of the cemetery, except upon the avenues; or to be driven or ridden at a rate faster than a walk; or left without a keeper, unless fastened to the places provided for the purpose.

III. All persons with fire arms or any article on sale are prohibited from entering the cemetery, and no refreshments, or party carrying refreshments will be admitted.

IV. All persons are prohibited from writing upon or otherwise defacing any monument, fence, sign or other structure within or belonging to the Cemetery.

V. All persons are prohibited from gathering any flowers, either wild or cultivated, or from breaking or otherwise injuring any tree, shrub, or plant, or from annoying birds, squirrels or other harmless animals within the cemetery.

VI. Dogs will not be admitted into the cemetery.

VII. Visitors must walk on the avenues and paths, and will not be allowed on any other portion of the grounds.

VIII. All noisy and disorderly persons will be expelled from the cemetery.

IX. No person in the employ of the Trustees is allowed to receive any gratuity for services rendered to visitors.

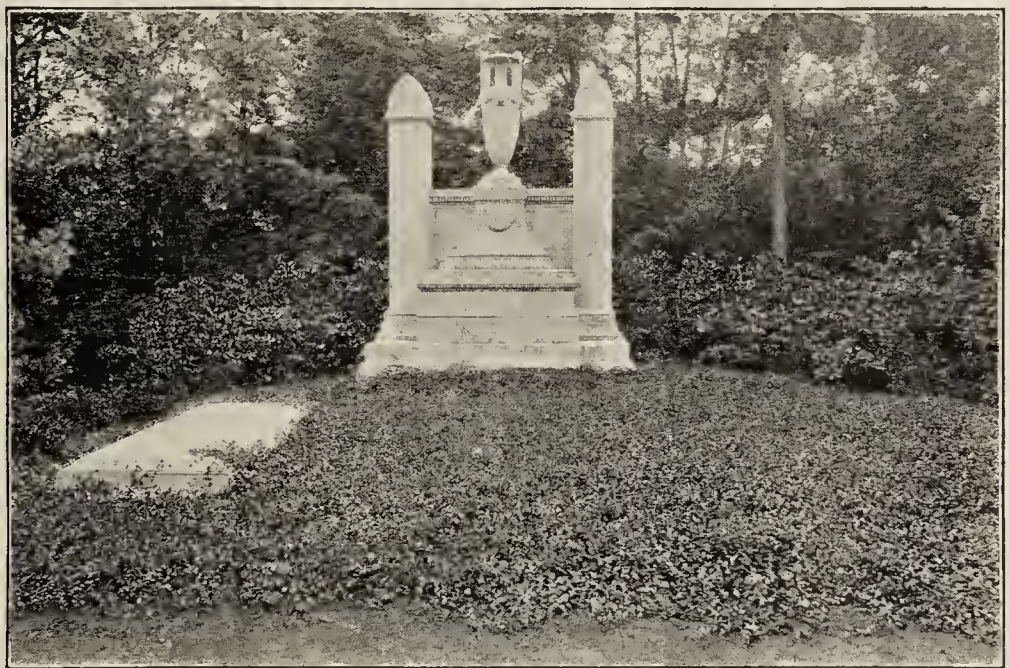
X. The Superintendent is authorized to cause the arrest and prosecution of all persons violating these regulations.

Thus it will be seen that there is an even grade of keeping things uniform, wholesome and really receptive in character. The stone yard, the perishable, stark, often ghastly marble is tabooed and an art garden of surpassing dignity and beauty is revealed in these silent undulating thirty acres.

The illustrations quite clearly comprehend the ideas of the landscape engineering and disclose the well kept, broad avenues and paths, an agreeable sylvan aspect of foliage and to the eye of the true gardener a sense of refinement quite befitting a modern cemetery and eminently worthy of emulation.

I have chosen four views in the cemetery which evidence the varied aspects of environment and memorials. The classic Blake monument offers an example with its guardian obelisks and Appine urn and contrasts agreeably with the tablet of copper, which seems so solidly fixed to the everlasting rock. Interesting also is the simplicity of the receiving vault over run with English ivy and nothing could be more beautiful than the sylvan avenue, the natural condition and quiet restfulness of the scene impresses one with a fine feeling for semi-rural beauty, graceful lines and forms, and light and shade.

Relative to the sale of lots it is stipulated that the price shall be for any and every foot twenty-five cents and this price includes perpetual care, a portion of the amount received being set aside, the interest of which is now nearly sufficient for the pur-



BLAKE MEMORIAL.

pose. It will readily be seen that in time, say fifteen years, an enormous fund will accumulate which will naturally, if it were desired, put a premium on the sale of lots, but I imagine the original rules will ever be kept intact and that the town will vastly benefit from its wise investment.

At the Town Hall Clerk Mr. Baker shows a superb system of keeping record of lots, interments, etc. He has constructed a book which is ruled by squares, each page shows the size of lot, locality and number of interments and character of adornment. These squares are scaled to represent one foot, so that if A owns a lot where used and two squares of one foot each are left on the border front of the lot, a restriction observed invariably. Thus Mr. Baker holds a complete map, or record as it were of the inhabitants who slumber in this "Couch



Magnificent" for reference.

The care of the Cemetery, trenching, grading and finishing is most thorough and with the income reserved from the Perpetual Care Fund investment which is not sufficient as yet to make the Cemetery self supporting, the towns people are philanthropic enough to make all deficiencies on the matter good, and the grounds will ever be kept as the original designs intended it should. An example well worthy of repetition in many other localities.

*Frank T. Robinson.*

#### Sculptured Monuments of Philadelphia.

To the small but intellectual band, and art loving minds that first founded, in 1871, the Fairmount Park Art Association, is due the thanks of the sculptors and artists of this continent and Europe, and the unqualified gratitude of the citizens and strangers who visit this city. Through their efforts the city and surroundings have been raised from the common place of mediocrity by the dictates of refinement and art. Fairmount Park, one of the finest in the world, containing as it does not less than 2798 acres of undulating grounds, valleys, natural falling waters, rocks and timber,



THE WOLVES.—EDWARD KEMYS, SC.



SYLVAN AVENUE, WALNUT HILLS CEMETERY.

33 miles of driveways,  $7\frac{7}{8}$  miles of bridle ways and 42 miles of footways, stands embellished with the outcome of the association's endeavor.

It bears the stamp of originality since it is the only one of its kind, and its purpose is to embellish, by the aid of voluntary contributions, the natural charm and beauty of Fairmount Park, by constantly adding statuary and other works of art until these treasures shall make the park famous, as the gardens of Rome. In June of 1871, a charter was granted by special act of the legislature and duly approved by the governor in February 1872. The membership numbering at its inception 446, has now enrolled no less than 1277 of this city's best known men and intelligent women.

To graphically illustrate the endeavors and successes of this association one must turn and look at its expenditures and then upon the reproduction of photographs of the statuary made, to illustrate this serial.

Twenty eight objects of art represent the purchases made by this association at a cost of \$200,000. It is significant of the times and purpose to say that when the society was first formed, few productions, and those of very mediocre description, were offered for purchase. After 22 years of scrupulous care and prosperity, the society is most respectfully acknowledged throughout the Art World and every sculptor is ambitious enough to aim for representation in the Fairmount Park collection.

The first purchase was made of Kemys model of "Two Hudson Bay Gray Wolves, quarreling over the Carcass of a Deer". This is situated in the west park near Girard Avenue Bridge, and overlooking the steep banks of the Schuylkill. The bronze casting was made by Robert Wood & Co., of this city, and rests on a rough rock ground supported by a 6 foot base of dark polished granite and plinth of same material. The group (life size) depicts the one wolf having seized the hind leg of the deer, while the other below stands with fore-





GEN'L GEORGE B. MEADE.—ALEXANDER MILNE CALDER, SC.

paws resting on the neck of the deer, with his tail curled under and in a pose of snarling defiance, gaunt, hungry and ferocious; ready to slay or be slain, in equitable adjustment of wolfish desire.

The attitude is strong, and the lines characterize the perceptive and retaining quality of the sculptor's mind; (for have I not seen them in crossing the steppes of Russia?) mark the hollowness and loose lying skin of the one looking up in the face of his erstwhile companion and now envied antagonist. That portrays hunger of 24-30 hours duration, which a good meal of horse, dog or sheep will in 45 minutes dissipate and cause to be blown out and bellied like a balloon, and yet with rapid digestion disappear almost in two hours.

It is to be regretted that the subject treated so cleverly, leaves an indistinct impression as regards the deer, the hind part stands out from the jaw of the wolf revealing the delicate lines of the tapered leg, but unfortunately the public is left to conjecture whether it is part of a deer, and this is made unanswerable since it is impossible for the average man or woman to look on the top of the pedestal standing nearly 6 feet 6. The paws of the crouching wolf, rest seemingly on the empty skin of the deer. If such be the case, of course it is acceptable, but conjecture should not enter into sculptured art. It should reveal clearly the intention of the sculptor, if affording food for mystification, then it is in part false. This first spirited group was erected in 1873, at a cost of nearly \$5,000.

\$2,000 for the model in full, \$1,500 for casting and the usual sundries making up the total.

The equestrian statue of General G. B. Meade occupies a good position on the Northwest of Memorial Hall and facing toward Horticultural Hall, Fairmount Park. The figures of horse and rider, above life size and yet scarcely approaching the heroic, are in bronze, designed and won after a hard fought competition, by Alexander Milne Calder of this city, and cast by the Henry Bonnard Bronze Co. of New York. Erected in 1888, it stands on a fine pedestal, 14 by 12 feet long, of rock face granite, with polished base or plinth, and polished crown mould. A glance at the accessories will show a faithful adherence to all the details by the sculptor, and yet unfortunately the weak lines of the left hand would not justify the idea that the reins held as weakly as they are, would be powerful enough to cause the horse to fall back upon the power of its haunches, and thus plant the fore feet with the determination shown or cause the lower jaw to be drawn with almost painful tension. The figure is bold and not wanting in the grace of good lines and dignity. There is no sense of the heroic displayed; the pose portrays the opponent of Lee, not as one would imagine him, eager to cut through the lines of the Confederates at Pipe Ridge, and hoping to cut off Lee's communications with Richmond, or after the three days struggle at Gettysburg; but rather in the act of acknowledging a salute of his battalions at review. The fatigue cap in hand hanging down over the saddle cloth, denies even this supposition, and raises the theory of a falsity. Military tenets supply the action of the inverted hand or exposure of the palm betokening submission, and the acceptance of such a salute by a superior officer being signaled by his showing the back of his hand with the index and second fingers raised to the chapeau, helmet, forage or fatigue cap. Thus it will be seen that the conditions of the pose would be more for a riding master, who after putting through some evolutions, reins in and salutes in response to the applause.

It is one of the most costly monuments at present erected by the Fairmount Park Art Association. No less than \$25,000 being paid for the figure of horse and man, not including the pedestal.

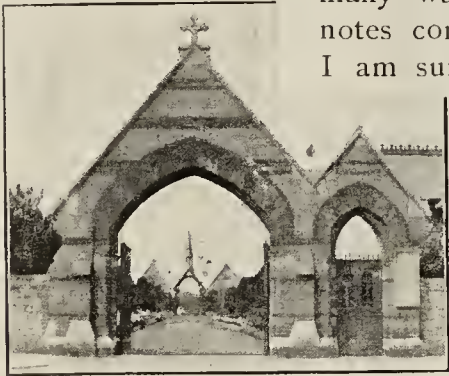
Did the sculptor intend to show Pennsylvania's General viewing the dead, then indeed one might accept the pose, but failing this theory, its pose is scarcely interpretable. Possibly the intention of the sculptor was simply to show General Meade and "Baldy"—the horse reining in after a hard and heated gallop. Mr. Calder has achieved a very fair success, as regards the portraiture of Gen. Meade.

*Walter Percy Lockington.*



### A Pretty Cemetery in England.

During my visit to England the past summer it was my good fortune to visit many a beautiful public and private grounds. Among others was the Cemetery at Ryde, Isle of Wight, and finding it a very pretty one and one made beautiful in many ways, I made some notes concerning it, which I am sure will interest your readers, and through the kindness of the general superintendent, Mr. Butcher, I obtained from him photographs of the entrance and of the chapel. The Cemetery is of about ten acres, and belongs to the town of Ryde. The smaller photograph shows the entrance gates, and standing there the visitor sees, at almost fifty yards distance, the chapels, with archway and spire connecting them. The larger photograph shows the reverse side of the chapels shown in the smaller one. One of these chapels is used by the Protestants, the other by dissenters, while the Catholics, who have a portion of the grounds to themselves, use neither one, but hold their services outside. The fifty yards between the entrance gates and the chapels display a most successful effort at ornamental gardening. The neat gravel road is rather lower than the surrounding land, especially on the one side. The slopes from the higher ground to the roadway had been planted with flowers, which were beautifully in bloom, and made of the entrance a lovely picture. In width these borders were about 4 feet. Perhaps just the same kind of flowers would not do here, but I name them as I found them. The right hand border had for an edging a row of the compact growing blue lobelia; next, the yellow flowered *Gazania splendens*; next, geraniums in various colors; then heliotrope. The left hand one contained as a border blue lobelia, with a white flowered one closely set to it, then assorted geraniums, and in the back rows assorted ever-blooming roses, flags, poppies and other perennials. As a background to both borders were many broad-leaved evergreens, for which this part of England is particularly famous. To aid in understanding the effect of the combination, I should add that the path alongside the flowers was made of red gravel. The two spreading evergreens which show, one on each side of the drive by the chapel, are of the *Picea pinsapo*, a tree very much planted in England. The tall tree on the right is the *Se-*



ENTRANCE TO AN ENGLISH CEMETERY.

quoia gigantea, which I find is rarely seen in first-class condition there, any more than it is with us. And near this tall tree is seen the ends of a few branches of the *Aruacaria imbricata*, which is a nice specimen of about 20 feet in height. Partly covering the wall of both chapels is to be seen the *Coton-easter microphylla*. It bears pretty scarlet berries, which its small, bright green foliage sets off to good advantage. On the northwestern side of the chapel was a fine bed of a fern, which appeared to be *Asplenium filix-mas*. The fronds were nearly 3 feet in length, and all the plants showed great luxuriance. As elsewhere in England, the *Lauson Cypress*, *Thujopsis borealis* and *Cupressus macrocarpa*, are largely used on the grounds, as is also the *Yucca gloriosa*. One *Lauson Cypress* was 20 feet high by as many in width; a *Thujopsis* 12 feet high by 15 feet wide, and a *Thuja gigantea* of like fine proportions. It will be seen that our Pacific coast evergreens have been largely drawn on here, and deodar cedars here and there are fittingly used. At the time of my first visit to this Cemetery, in early June, the flowering horse chestnut was in splendid bloom. So also was the laburnum, and hawthorns of various colors added their charms. I found the red flowered horse chestnut a great favorite in England, seeing more than one avenue of it, and splendidly it thrives. The burial lots are not as wide as are usually found in cemeteries at home. Ours are usually large enough to take in all the members of a family in separate graves, but

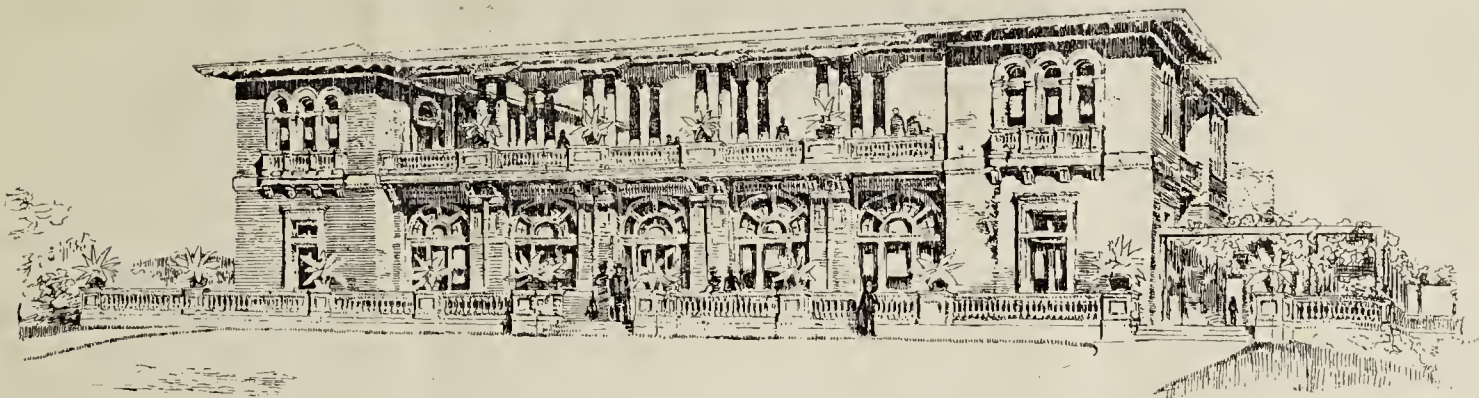
quoia gigantea, which I find is rarely seen in first-class condition there, any more than it is with us. And near this tall tree is seen the ends of a few branches of the *Aruacaria imbricata*, which is a nice specimen of about 20 feet in height. Partly covering the wall of both chapels is to be seen the *Coton-easter microphylla*. It bears pretty scarlet berries, which its small, bright green foliage sets off to good advantage. On the northwestern side of the chapel was a fine bed of a fern, which appeared to be *Asplenium filix-mas*. The fronds were nearly 3 feet in length, and all the plants showed great luxuriance. As elsewhere in England, the *Lauson Cypress*, *Thujopsis borealis* and *Cupressus macrocarpa*, are largely used on the grounds, as is also the *Yucca gloriosa*. One *Lauson Cypress* was 20 feet high by as many in width; a *Thujopsis* 12 feet high by 15 feet wide, and a *Thuja gigantea* of like fine proportions. It will be seen that our Pacific coast evergreens have been largely drawn on here, and deodar cedars here and there are fittingly used. At the time of my first visit to this Cemetery, in early June, the flowering horse chestnut was in splendid bloom. So also was the laburnum, and hawthorns of various colors added their charms. I found the red flowered horse chestnut a great favorite in England, seeing more than one avenue of it, and splendidly it thrives. The burial lots are not as wide as are usually found in cemeteries at home. Ours are usually large enough to take in all the members of a family in separate graves, but



VIEW OF CHAPELS AND ENTRANCE FROM INSIDE.

a great many of the enclosed lots here contain but the one grave. I noticed, however, that in many cases more than one interment had been made in the same grave. There are all kinds of methods of enclosing lots as there are in certain localities with us. The railings of some lots were beautifully fes-





REFECTORY BUILDING, FRANKLIN PARK, BOSTON.

tooned with roses. The sort used was the tea, Gloire de Dijon. A plant or two were set to each side of the lot and then trained hedge shape. I saw these bushes in flower, and a lovelier and more appropriate display I never saw. A thick, low bushy edging is often made of the *Clematis montana*, a sort bearing good-sized white flowers and having the free growth of *Vitalba* and *Virginiana*. If hardy here, it will be a valuable addition to our vines. I was particularly struck with the beauty of the weeping ash and weeping elm as seen in this and other cemeteries in England. They are all grafted on tall stems, 10 feet or more high, and form delightful arbors. Our nurserymen graft them too low. The outskirt of this Cemetery has been heavily planted with all sorts of shrubs and trees of an evergreen character. A border 20 feet wide contains pines, English laurels, hollies, *Euonymus*, *Aucubas*, Mountain ash and like trees, securing seclusion thereby. Graves and lots are decorated much as they are with us. I witnessed an interment in a neighboring Cemetery during my stay in England in which each mourner carried some floral emblem which was placed on the grave of the young girl they buried. There was not less than a dozen crosses, wreaths and like designs, and these had been largely made up of flowers gathered in the fields.

*Joseph Meehan.*

#### Refectory Building, Franklin Park, Boston.

The Refectory Building in course of construction in Franklin Park, Boston, an illustration of which is given above, is from plans by Messrs. Hartwell & Richardson, architects. The character of the building is Italian and it covers an area of 121 ft. by 69 ft. The materials are buff brick and terra cotta, and the terrace is laid up in field stone, to be covered perhaps by climbing plants. The plan of the structure is very simple. On the ground floor is a large restaurant and a private dining-room. Above is the roof garden, which forms in effect a second story, having pavilions twenty-one feet

square at each corner, connected by covered galleries on three sides, the remainder of the space being open to the sky. On a level with the ground floor is the pergola, which extends across the west end and along the southerly side, and which varies in width from twenty-eight to fifty feet. This is paved with brick, and has a trellised roof supported by open groups of wooden columns. In the centre of each group provision has been made for vines, which will twine around the columns and spread over the latticed roof above. The refectory will be ready for use next summer.

The structure has been criticised as being more suited to warmer climates than the region of Boston.

#### Horticultural Education—Practice and Theory.\*

Horticulture is fast gaining a place in the courses of instruction in most of our colleges. A few years ago this science was little studied, but in our agricultural colleges one or more courses in horticulture are now taken up. We can hardly expect to send out men ready to take a position from the schools, but we can give them much knowledge in a short period of time, which will help make their work easier and clearer. In teaching, the knowledge given is the result of past experience of other gardeners. We use their methods and endeavor to improve upon them. Every student should fully understand the necessity of improving upon the already existing method of growing, if possible.

In all agricultural colleges and experimental stations, I learn that it is their aim to combine theory with practice, lectures being followed by practical work. At the St. Louis Botanical Gardens, under the directorship of Prof. Trelease, the work is undertaken in such a manner as to turn out good practical men. The course is similar to that of which I shall speak of later under the future horticultural school. Four years are required before

\*Extracts from a paper read at the Eleventh Annual Meeting of the Society of American Florists, Pittsburgh, Pa. By Chas. Jackson Dawson, Boston.



the garden pupil is supposed to complete the course, the first year being devoted entirely to work in the greenhouse and garden; during the remaining three years the time is equally divided between the lecture room and manual labor. At Cornell University, at Ithaca, N. Y., Prof. Bailey is making the horticultural department one of the best in the country. It is equally divided into two parts: one devoted to research and the other to teaching. About 10,000 square feet of glass is used in which is grown a general line of greenhouse and stove plants. Forcing of vegetables is taken up deeply, and of late years they are making a specialty of the chrysanthemum and violet. The courses of instruction are numerous, as Greenhouse Construction, History of Horticulture, Propagation, Soils, etc., Pomology and Forestry, besides various botanical courses.

At Bussy Institution, a department at Harvard, horticulture is taken up under Prof. Watson, and as far as it goes is very thorough, but lack of funds prevents much practical work being undertaken. The course is usually embraced in one year's time in connection with agriculture, chemistry as relating to agriculture and botany. A general course is given, covering a wide range from the tillage of soils, etc., various means of propagating, greenhouse construction, cultural points in regard to most important plants, and an insight into the vegetable and fruit world. Injurious insects and known remedies are taken up, and a few lectures on landscape work. A course is also given on trees and shrubs, commencing with the first order, ranunculaceæ, and a description, uses, means of propagating are gone over. A similar course is also given on herbaceous plants. Most of the men studying here prepare themselves for landscape gardening, and in connection with their work take up geology, architectural engineering, and a deep study into botany. The men are given walks once a week through Arnold Arboretum where they get thoroughly acquainted with the trees and shrubs. It is a noticeable fact that most of our institutions tend to treat pomology and market gardening more than floriculture, and so with most of the experimental stations. This does not seem right as the states pay for horticultural research work, and you should insist that more work in floriculture should be undertaken.

In regard to the practical or apprenticeship system, I am sorry to say we have none in this country. It is simply hire a man and get the most work out of him you can; especially is this so at a commercial place. You hire a boy to learn the business, and unless he picks up the information himself he learns but little, and you get your money's worth out of him. What can a boy learn if he is

set hoeing weeds from May to October? Nothing!

\* \* \*

There are few trades which may not be learned in much less time than that of gardening, which requires no small degree of knowledge and ingenuity to perform it well.

Summing up practice with theory, we find that college education is a good thing to have. To a boy with a clever and active mind, and a wholesome kind of knowledge, college education is the greatest boon he can have, and his chances for success in life are better than one hampered by an unfinished education. He is able to grasp business and scientific problems with a firmer hand; knows how to use his mental powers; how to concentrate his energies, and to adapt himself quickly to situations that confront him. Above all he must learn to reason from cause to effect and vice versa. We must remember that in affairs of life no comparisons can be made with the phenomenally gifted, who are endowed by the Almighty from their birth with powers far beyond the equipments of their fellows. The whole human race profits by the spread of college education.

\* \* \*

And now to the principal reason for the writing of this paper, and that is the necessity of a National Horticultural School. The United States is fast becoming rich in its grand public park systems, which are making a complete network all over the country. All the States and large colleges are establishing botanical gardens or experimental stations of more or less size, and generally speaking, there is a rapid advancement being made in the line of educational institutions connected with horticulture.

New York is soon to have a most complete botanical garden—that is, the land has been appropriated, and no doubt the work will rapidly advance. Whether it will be a credit to this country and compare with the most famous botanical gardens in the world—namely, the Royal Gardens at Kew—remains to be seen.

\* \* \*

The old school is fast dying out, and we need men to replace them, and for that reason I advocate a National School of Horticulture that will, if nothing else, give its men a good send-off into their future work.

This school should be of such fame and proportions as regards its good qualities, that everyone of you would wish to send your children to it to be given the elementary education for their future business.

Horticulture has such a wide scope that it would be no small matter to establish such a school as is



necessary. It should embrace every branch, both from a practical and theoretical point, that will be likely to come up before the incoming generation.

\* \* \*

We need such an institution and must have it. How to get it and where to establish it, is another question.

The United States has already been very liberal in the establishment of its experimental stations and state agricultural colleges, and though these colleges take up horticulture indirectly as one of the courses, still it does not serve the purpose.

As regards our large colleges, horticulture is taken by some of them, but not very deeply, merely because sufficient money has not been left for that purpose, the public benefactors usually leaving their money for other branches, which are already well off.

\* \* \*

Look at the amount of money being spent yearly for public parks, and so forth, throughout the country. Why not put a little more money to such places, and make a grand educational institution out of it?

The public could have the benefit of it just the same, as it could be laid out in the manner of a large estate, park, or botanical garden, and always open to the public. This would in no way interfere with the work of the students. I say, always open to the public. Of course, some departments should be closed from the public certain hours of the day to allow work to be done that could not be done with strangers about. Thus you see you would not only educate a limited number of students, but the world at large, and create a greater interest in plants and flowers. Special attractions or exhibitions should be offered from time to time, as is the practice at Schenley Park, and the place should become as famous as Kew.

---

#### Trees.

THE BEST SEASON FOR TREE PLANTING:—It does seem as if the question as to the best season for planting will never be settled, and it never can be settled by any general rule. What may be good for one location would be bad for another, although but a few miles apart. In this part of the world, Eastern Pennsylvania, admirable success is always secured by planting as early in the fall as possible after rains have softened the soil sufficiently to enable the ground to be dug into. A correspondent from Boston tells us that he always has complete success by planting in August, and he plants very extensively too. One would suppose that where the winters were very severe, and cold winds strong, the transplanted stock would dry out

in the winter time. If this is the case, planting should be deferred until spring,—but even then there is this difficulty that the hot summer weather will follow so soon after planting that trees suffer from dying out in the same way. There can be no general rule. Every one with a little experience should endeavor to find out the successful practice of his neighbor as well as to experiment a little for himself.

\* \* \*

TRANSPLANTING LARGE TREES:—Part the first of volume 19 of the "Journal of the Royal Horticulture Society of England," which has recently appeared, has a lengthy and elaborate article on the transplanting of large trees. The method employed is extremely costly and is in striking contrast with the simplicity with which the art is practiced in America. It is found, in this part of the world, that a large tree can be removed just as successfully as a small one, providing the same care is exercised to get all the roots in the large tree, as we would do in the case of the small one. No intelligent planter now cares more about the removal of a large ball of earth with a big tree than a little one. The only care required in a comparatively small tree is to get all the roots possible, and this is all the care required for a larger one. The digging has to start a little farther from the trunk in the large trees, and that is all the difference. In a small tree digging may start at two feet from the trunk—in a larger one three feet; and four and five feet, according as the tree increases in size; and the next care is in seeing that the earth is properly packed in about the roots when it is transplanted, and not merely packed in, but pressed in and hammered in as tightly as possible. The writer has known trees between two and three feet in circumference and twenty-five in height to be moved several miles and replanted all within a cost of twenty dollars; and the trees would subsequently thrive just as well as small saplings would do.—*Mechans' Monthly for November.*

---

It is an unquestioned fact that public parks and playgrounds are one of the most important factors in the real, practical development of cities. Communion with nature is always elevating and the good done to the overworked denizens of crowded city streets in wandering through green pastures and beside still waters is incalculable. The mind is purified, the eye is educated, the heart delighted and the tired body refreshed. Innocent pleasure and healthful exercise are combined in a fine and bracing air, and it can be truly said that a park is the heart free beating, the lungs free breathing of a great city.—*O. C. Simonds.*



**Guild of the Kew Gardeners.**

The youngest bantling among the worshipful companies of the City of London is a guild of the Kew gardeners—past and present. They were organized in 1893 and appointed a committee to forward the scheme, and devise means for the publication of a journal and directory of all living Kewenians, as far as possible, and maintain communication with them. The scheme has been warmly indorsed by the officials.

Thus it will be seen that the object of the guild, so far, is the laudable one of uniting all Kew men in a bond of fellowship by means of a journal which enables them to communicate with each other. The members in most parts of the world responded at once. There are several remaining, however, whose whereabouts have not been sufficiently ascertained, and it is respectfully asked that American and colonial newspapers which take an interest in the Royal Gardens and their work will give any notice of the guild and its objects which they may find possible. The technical journals have done this, but it is suspected that many of the men have drifted away from gardening pursuits in these countries. The Secretary of the Kew Guild or the editor of the journal will be glad to hear from Kew men wherever they may be in the world.

The oldest of the Kew gardeners, Mr. J. W. Thompson, died last year, and bequeathed enough New South Wales stock to “yield in perpetuity and for all time” a sufficient amount of money to give the guild the character of an endowed institution, and his example has since been followed by others. Such stocks will stand in the name of the Director of the Royal Gardens, Kew, England, and it is hoped that in time they may be sufficiently large to enable the members to largely increase the usefulness of the guild and its publications. The journal has been officially applied for by the British Museum and libraries in the United Kingdom, the United States, India, and the colonies. There are a few copies left, however, which will be sent to Kewenians who apply as above.

Taking the Directory (1895) of the Kew men known to have come to the United States, the following results of their present known occupations are obtained:

Editors, etc.....	2
Landscape gardener.....	1
Botanic gardeners.....	5
Head gardeners.....	5
Nurserymen.....	3
Florists.....	2
Park gardener (!).....	1
Wood carver.....	1
Unaccounted for employments.....	11
<b>Total.....</b>	<b>31</b>

A worshipful company of gardeners is rather an ancient affair in Britain. James I. seems to have granted them their first charter.

Nowhere can one find, however, that the gardeners caused or became involved in any trouble, and it would seem that the intentions of the Kew men who are resurrecting this old guild are quite as peaceable and worthy of the same confidence which King James I. extended to the gardeners of “ye olden tyme.” *James Mac Pherson.*

**GRASS PATHS.**—The editor of *Gardening*, in the course of an article describing some of the features of the Forest Hills Cemetery, Boston, speaks of the grass walks in the place of the gravel paths, the latter giving the landscape a needlessly cut-up patchy appearance. By filling these up level with the lawn and sowing them with grass so as to form part of the lawn, they can be kept even, smooth, clean and well mown, and so far as a pathway is concerned serve every purpose that the old gravel walk would; in fact, the grass is better, for it permits of more people walking abreast than the gravel paths would allow. Mr. Falconer also suggests that this is a pertinent point for private gardens also, for one of the commonest mistakes a person is apt to commit in planning a garden is to cut out too many walks in it.



AN ITALIAN MONUMENT.



## PARK NOTES.

South Pittsburgh, Pa., is seriously agitated over the question of small parks, and the Board of Trade has joined in the demand.

\* \* \*

H. W. Staples, proprietor of the Old Orchard House, Old Orchard Beach, has announced to the local board of trade an offer of the free use of the track known as Fern Park, to be used as a public park, providing the citizens will beautify it.

\* \* \*

Some of the features in the floral department at Washington Park, Chicago, next year, will be an extensive tulip display, and a lake devoted to hardy aquatic plants,—that is aquatic plants which will not require artificial heat to perfect them.

\* \* \*

The gifts of Mr. C. H. Hackley to the city of Muskegon, Mich., now aggregate \$411,000, of which \$200,000 is for library purposes; \$26,000, soldiers monument; \$45,000, park; \$10,000, Hackley park assembly; \$130,000, manual training school.

\* \* \*

Shreveport, La., is working in earnest to establish what has long been needed, an attractive piece of park grounds. An association including a number of prominent ladies, who are thoroughly aroused, has been formed, and subscriptions are coming in to assure a successful outcome.

\* \* \*

Mr. J. C. Olmsted has been examining Indianapolis in relation to its park system. His opinion is that Indianapolis is gaining a size that imperatively demands attention in the securing of lands for park purposes. A lack of scenic effects about Indianapolis will necessitate much study in laying out the system.

\* \* \*

The city council of Savannah, Ga., has agreed to purchase the title to the old South Broad street cemetery in order to turn it into a colonial park. This is the old colonial burying ground of Georgia, originally used by Oglethorpe's colony. The city will spend \$10,000 or more to make the future park attractive.

\* \* \*

We note that the park question has taken serious hold of the press generally, and frequent allusion is made to the advisability of immediate action by all communities toward securing park sites in our smaller towns, while such can be obtained at reasonable cost, and while there are still beauty spots reserved from the ravages of the commercial idea.

\* \* \*

The Chicago Lake front project for a park is now fairly started, the city having come to an agreement with the Illinois Central R. R. Co., a city ordinance passed governing the scheme, and the secretary of war having given his consent to certain propositions connected with the harbor. Work will commence at once and the magnificent water front of Chicago, will in a few years be one of the grandest parks in the world.

\* \* \*

Among the results of the great gathering of the Westernmen at Vicksburg, Miss., incidental to the Waterways Convention, was the organization of the Vicksburg National Military Park Association. The object of the organization is to foster the foundation of a national military park at Vicksburg, similar to those at Gettysburg and Chickamauga, which will belt the city on three sides, and be, as one of the promoters expressed it, a "monument to American manhood." The project is a new one, but has won sudden favor.

Pittsburg, Pa., has been advised that a gift of \$100,000 to beautify its parks is available. One of the stipulations is that part of it must be used for statuary. This is a suggestion in the right line provided competent judges of the nature of the statuary, its suitability for the purpose and its ultimate location, have charge. It is to be hoped that the donor will demand this, for it would be setting a valuable lesson and tend to reduce the ridiculous judgments of the politician who generally gets there.

\* \* \*

It is reported that the war department has plans arranged for the establishment of a military post, for both cavalry and infantry, a three mile artillery range and other features at the Chickamauga Military Park. The entire area of 7,000 acres embraced in the park will be enclosed by a stone wall. The lay of the land will make it a famous training ground for troops and one of the best rifle ranges on the continent. Of late years the policy of the department has been concentration of troops within easy call of railroad centers and a reduction of the number of posts on the frontiers. Congress will be called upon for a liberal appropriation for this work.

\* \* \*

Beautifying public places is quite in line with park work, and it is gratifying to record to how great an extent this display of public spirit is showing itself at Great Barrington, Mass. Col. Wm. L. Brown, of New York, who has a country residence there has presented the town with a beautiful drinking fountain. It is about fifteen feet high. The main shaft is of polished Quincy granite and the remainder of dolomite. It is surmounted by a full size bronze figure of a newsboy crying his papers. The fountain is situated in a small park, given in perpetuity to the town by Col. Brown. The statue was designed and executed by David Richards of New York, and the casting was done at the bronze works of Maurice J. Power of New York.

\* \* \*

Joseph Meehan, of Philadelphia, says: "Wherever I go in England, I always meet with public parks. Out-door life is so popular that parks or gardens are deemed essential, and they are always well patronized." The Philadelphia *Examiner*, commenting on this, says: We have had so much out-door in this country to which everyone was given free access that the necessity of parks has not been forced upon our attention, except in the great cities. But now that one is so frequently confronted with the notice, "No trespassing," even in strictly rural communities, the need of public places of resort is coming to be more fully appreciated. The smaller cities and villages would do well to "take time by the forelock" and provide ample space for recreation before the cost of land increases beyond the point at which it can be profitably acquired.

\* \* \*

Philadelphia has been active in the small park idea. One proposition has seemed to be greatly in favor, that of including Bartram's garden in the list. This is so well known to the older residents and it was the first botanical garden ever planted in the United States. In it are to be found trees brought to the spot by John Bartram, who is no less a man than the great Linnæus pronounced to be the greatest living botanist over a hundred years ago. In this garden are trees from the far south, including a marvelous specimen of cypress which has grown to gigantic dimensions, and its preservation is a matter of interest to every Philadelphian. The rapid development of the twenty-seventh ward, in which Bartram's garden lies, it being rapidly covered with dwellings of a good class, will also be a further reason for giving this locality the benefit of a liberal appropriation.



## CEMETERY NOTES.

The Mountain View Cemetery Association, of San Francisco, Cal., has suffered a loss said to amount to over \$8,000, by the defalcation of an absconding Secretary, Edward P. Outram, who had enjoyed the confidence of the corporation for some ten years.

\* \* \*

The vandal has reached Minnesota, considerable damage having been done in the two cemeteries of Carlton. Some of the hoodlums of the town are adjudged the guilty parties. Since "hoodlumism" has taken to itself the privilege of despoiling our cemeteries, no mercy should be shown the delinquents; a sudden and effective punishment should be meted out without delay.

\* \* \*

An aboriginal cemetery of large dimensions has recently been discovered at Milford, O. W. K. Moorehead, Curator, of the State Museum, has been making excavations. A large number of human skeletons have been exhumed. In the graves are found a great and diverse variety of weapons, trinkets, utensils, ornaments and religious symbols, in stone, bronze and silver. It is not only a fund of curiosities, shedding light on the prehistoric past, but an invaluable acquisition to ethnological science.

\* \* \*

The question of perpetual care has engrossed the attention of the trustees of the Manchester, N. H., cemetery, for some time, and has at last been definitely settled, and a new line of policy adopted. Hereafter the trustees will accept donations of \$100 for perpetual care of lots not exceeding 250 square feet with 40 cents per additional foot; this will bring it within reach of citizens of moderate means. The perpetual care fund now amounts to \$40,000 which is invested at 5 per cent, and the trustees believe that the above policy will secure the desired result.

\* \* \*

Cemetery superintendents have several busy times during the year, not the least being the work incumbent upon them due to preparing for winter and incidentally for next spring. The very dry summer experienced nearly everywhere, while it enabled a large force of cemetery employes to be turned over to the work of improvement and extension, nevertheless has to be compensated for by the considerations involved in making good the ravages of the drought and the rehabilitation of the sunburned spots. A beautiful fall has done much to help build up natures' constitution again, and with man's intelligence next spring will undoubtedly see improvement all along the line.

\* \* \*

War is being made in earnest in San Francisco against cemeteries within the city limits. The cemeteries in that city are mostly placed on high eminences, and a scare has taken hold of the inhabitants, on the presumption of unhealthy conditions arising therefrom,—the idea prevailing that the seepage from the cemetery reaches the lower levels to the imminent danger of the public health. This is largely discredited in the leading papers, but they do present two good reasons why cemeteries should be located outside the city—the check they present to the growth of the city and the menace to subterranean water supply. There is talk of condemning the existing interurban cemeteries and compelling their removal.

\* \* \*

During the fiscal year, 1894-1895, 7,340 white marble headstones were provided to mark the graves of soldiers, sailors and marines buried in national, post, city, and village cemeteries,

and the sum of \$19,454.88 was expended in necessary repairs to roadways to national cemeteries, which were constructed by special authority of Congress. An examination of the records shows that the appropriation made by Congress for the establishment, maintenance, and improvement of national cemeteries, including pay of superintendents, head-stones, monuments, purchase of sites, and construction and repair of road-ways, from their inception to June 30, 1895, amounted in the aggregate to \$8,165,636.47.

\* \* \*

A remarkable condition of affairs has occurred at Reynoldsburg, O., by which for a time they had no place to bury their dead. Some time ago the town concluded that no more burials must take place in their little cemetery on the outskirts of the place and laid out a new one beyond the corporation line. There was no way conveniently reaching it, so a petition was sent to the County Commissioners to build a road to the new cemetery. It was granted and a road was begun at the further end of the new cemetery to run around it and reach town. The fork had been completed about half way, when a halt was called on account of the cost and work was stopped. At last accounts the two ends of the fork were inviting the towns people to come across lots to make use of them, and people began talking about building a crematory.

\* \* \*

The Supreme Court of Illinois has just rendered a decision in the case of Bourland and others vs. the Springdale Cemetery Association of Peoria. The main contention was the diversion of large amounts of money to the personal use of the members of the Association. The defendants admitted all the allegations and comforted the promoters of the suit by assuring them of an intention to continue in the same line. The judicial opinion holds that the Cemetery Association has the right to appropriate the proceeds of the lots sold, to the individual members for their own private use, and that the lot owners are without remedy. On the face of it, this is evidently the result of a very defective charter.

\* \* \*

The American cemetery in Mexico, is situated on the southwestern boundary line of the capital. It is American in the fullest sense of the word, for the full and perfect title therein is vested in the United States, and its management and control are in the hands of the War Department at Washington. It occupies two acres of ground, and in it repose, side by side, the American and Mexican, the German and the Frenchman, as well as other foreigners, for only of late years the right of burial within its walls has been restricted to natives of the United States. In 1873 it became subject to the rules and regulations affecting United States national cemeteries, and by act of Congress, September 28, 1880, the sum of \$10,000 was appropriated "for the purchase, walling and ditching of a piece of land near the city of Mexico for a cemetery or burial ground for such of the officers and soldiers of the United States Army in the war with Mexico as fell in battle or died in and around said city and for the interment of American citizens who have died or may die in said city." The property was conveyed to the United States in 1851 by Manuel Lopez in fee-simple for the consideration of \$3,000, and since then it has always been the object of much solicitude on the part of the American residents of Mexico. The site is in the shape of an oblong square, and is entirely surrounded by substantial walls, along whose western sides runs the Consulado, or San Cosme river. The grounds are attractively laid out. At the northeast corner is the iron entrance gate. Inside the entrance to the right is the lodge, the first story of which is of stone, with a double archway and portico, the residence of Capt. John Ayres, the United States superintendent. There



are but few graves on which are not to be found the floral mementoes of love and friendship. The only heroes who sleep in the ground are nameless ones, the 750 soldiers who were killed on the plains of Mexico, whose bones are mingled together in a single grave. In memory of these a simple granite shaft about six feet high standing on a square pedestal has been raised and on top is a torch of diminutive size, made also of dark granite. On one side is the inscription:

To the memory of the American  
Soldiers who perished in this  
Valley in 1847, whose bones,  
Collected by their country's order,  
Are here buried.

On the other side is a marble tablet inserted in the granite, on which are written without comment:

Contreras  
Churubusco  
Molino del Rey  
Chapultepec  
Mexico.

#### Cemetery Accounting, IV.

Probably the most important of all cemetery books is the Record of Interments. Such a record is kept in most cemeteries and should be in all. The form adopted may differ in arrangement, but the system generally is based upon the same idea—that of keeping the full details connected with each interment.

The importance of keeping a record of such details is frequently disregarded in smaller places, where but little more than the name of the deceased, age and date of burial are preserved. On the other hand, some of the smaller cemeteries keep a complete biography of each resident of the "silent city," which has, of course, a certain local value.

There is no doubt whatever that between these two extremes a proper and sufficient record should be made, as past experience in unexpected inheritance difficulties has made apparent over and over again. Local history has also rights in the matter.

The Record of Interments ordinarily kept by the principal cemeteries may be classified as follows: No. of Interment; Name of Deceased; Place of Birth; Late Residence; Age; Sex; Social State; Date of Death; Cause of Death; Date of Interment; Place of Interment; Section and Lot; Name of Undertaker; Name of nearest Relative, Friend, or Physician.

Important features in such books, which should not be overlooked, are quality of paper used and substantiality of binding, as the Record of Interments in any cemetery, being almost in constant use, requires that it should be equal to the wear and tear incident to its continual service.

THE CEMETERY OF SPRING GROVE, CINCINNATI, O.—The annual meeting of the lot-holders of Spring Grove Cemetery, Cincinnati, O., was held last month, at which the election of officers was held and reports received. Complimentary resolu-

tions were unanimously passed commending the efficiency of Mr. Salway, superintendent, and Joseph C. Spear, secretary. The secretary's report showed receipts, including last year's balance of \$347.78, amounting to \$74,177.94. This comprised among other matters: Sale of lots, \$29,785.45; interments, foundations and single graves, \$20,031.18; care of lots, \$6,918.35; trust fund, \$3,330. The disbursements amounted to \$70,146.15, which included: Labor, material, watch and gatekeeper, \$27,618.52; interments and foundations, \$7,752.81, and salaries, \$9,450. The trust fund for perpetual care amounts to \$28,700. The number of lots sold during the year were 97, and fractions 29, equal in area to 44,619 square feet; number of burial permits, 1,402; number of single graves occupied, 11,374; total number of interments to date, 58,342, and number of lot-holders, 9,538.

Among the interesting matter in Mr. Salway's report is the following:

"The labor during the year amounted to 15,996 days, 3,476 days less than the previous year; the exceedingly dry weather has prevented the grass from growing, and in consequence the mowing and cleaning of the grounds has not required as much labor the past as that of the previous year by 3,549 days, enabling us to supply that amount of time to the extension and improvement of new grounds. We have improved about four acres of land and have made and stoned 76,000 square feet of roads. Some of the improvements made during the past year have necessitated the moving of 40,000 yards of earth. The rainfall is far below the average, only 23 inches of water for the past year, the average temperature for the year 53½ degrees, the highest being 97 degrees, the lowest 10 degrees below zero."

#### Obituary.

The Association of American Cemetery Superintendents has lost two of its members in recent months.

On September 28th, there passed away at Bay City, Mich., Mr. George Renshaw, the first and only superintendent employed on Elm Lawn Cemetery, Bay City, Mich. He succumbed to Bright's disease, after an illness of only three months, aged 46 years. He was buried in the cemetery he had done so much to beautify.

\* \* \*

On October 13th, Mr. James Hargraves, superintendent of Wiltwyck Rural Cemetery, Kingston, Ulster Co., New York, died aged 69 years. For eighteen consecutive years he had had charge of the above cemetery, quite a long service faithfully performed.



## NOTICE

**Association of American Cemetery Superintendents.**

Toledo, O., Nov. 14, 1895.

The proceedings of the Ninth Annual Convention of *The Association of American Cemetery Superintendents* which was held in the city of Richmond, Va., in September of this year, will be ready for distribution soon after Dec. 1, 1895.

Those desiring copies will please order them at once and remit with order at the following rates, viz:

Single copies.....	\$ 25
3 " .....	75
6 " .....	1 25
9 " .....	1 85
12 " .....	2 50

Postage prepaid to any part of the United States and Canada.

FRANK EURICH,  
Sec'y and Treas., A. A. C. S.

**Publisher's Department.**

NOTICE TO SUBSCRIBERS, If this notice is marked with a blue pencil it indicates that your subscription to PARK AND CEMETERY has expired and a renewal of same is solicited.

Park Commissioners and Cemetery trustees are requested to send us copies of their reports.

Photographs and descriptive sketches of interesting features in parks and cemeteries are solicited from our readers.

PARK AND CEMETERY wants the names of every park and cemetery official or employee who would be likely to be interested in this paper. To the many subscribers who have sent in such lists of names, we return our thanks. There are many more that we should hear from.

Subscribers are again reminded that we want brief notes on any feature of park or cemetery work that will be of general interest. PARK AND CEMETERY is the only publication of its class and earnestly solicits the co-operation of subscribers in making it a help to all identified with such work.

Thomas Meehan & Sons, Nurserymen and Landscape Engineers, have been engaged to prepare the plans for Hillside Park, near Philadelphia. A tract of land adjoining Hillside Cemetery and belonging to the same corporation, upon which are situated the office and residence of the superintendent. This cemetery is destined to become one of the most popular around Philadelphia.

THE SOIL: Its Nature, Relations and Fundamental Principles of Management. By F. H. King, Prof. of Agricultural Physics in the University of Wisconsin.—The Rural Science series, edited by L. H. Bailey. New York, MacMillan & Co., 66 Fifth Ave., price 75 cents. This is the initial volume of "The Rural Science Series," and in the editorial preface Prof. Bailey introduces it and suggests the reasons for the publication of such a series. This book illustrates the methods of science as applied to a consideration of soil and its uses, conditions and management. The author, Prof. King, says he has endeavored to make the work give to the reader a rational presentation of the fundamental principles of the soil as they relate to the immediately practical aspects of agriculture. The book contains some 300 pages and information enough to make the price absolutely insignificant. Such works from authoritative workers in the field they cover are of inestimable value, and also indicate the value of the Agricultural Experiment Stations.

## TRADE CATALOGUES RECEIVED.

Hardy Ornamental Trees, Flowering Shrubs and Vines, Parsons & Sons Co., Kissena Nurseries, Flushing, N. Y.

Palms, Dracenas and decorative plants, W. J. Hesser, Plattsmouth, Neb.

Lawn Mowers. The Philadelphia Lawn Mower Co., Philadelphia, Pa.

Wire and Iron work for cemeteries, stables, etc. E. T. Barnum, Detroit, Mich.

**Testimonials.**

R. J. Haight:—The three books of record came to hand a few days ago. The books suit our association, and I have shown them to a great many of our merchants, bankers and lot owners, and they express their unqualified approval of such

complete records. They help me very much in my work and in the estimation of our people.

R. D. Boice, Sec'y. and Treas.

*Oakwood Cemetery.*

R. J. Haight:—Enclosed you will find one dollar in payment for subscription to PARK AND CEMETERY. I am sorry it is not published twice a month.

John Amschler, Edwardsville, Ill.

R. J. Haight:—My best proof as to how greatly I appreciate your paper will be my check herewith enclosed for another year. I think all persons interested in parks or cemeteries should have it.

E. Clarence Simon, Harrisburg, Pa.

R. J. Haight:—Enclosed please find one dollar to extend my subscription to PARK AND CEMETERY. It is a publication that neither I nor any cemetery official can afford to be without.

Wm. Miller, Canajoharie, N. Y.

*R. J. Haight, Publisher.*

I must compliment you on the exceedingly neat appearance of your paper, especially since you have changed the name as well as to general high tone. I think it is just the kind of a paper needed for park and cemetery officials, and wish you every success. Harlan P. Kelsey, Kawana, N. C.

**Interment Record and Lot Book.**

This system is thought to embrace the best features of the most popular forms of burial records now in use and may be adapted to large or small cemeteries. The Interment Record gives all of the necessary information in regard to the deceased, and the Lot Book locates every grave, so that it can be readily found at any time. The books are printed on heavy paper, substantially bound and furnished in different sizes, depending upon the requirements of the cemetery.

**R. J. HAIGHT, Pub.,** 334 Dearborn St., Chicago.



# PARK AND CEMETERY.

FORMERLY THE MODERN CEMETERY.

A Monthly Journal Devoted to Parks and Cemeteries.

R. J. HAIGHT, Publisher,

334 Dearborn Street, CHICAGO.

Subscription \$1.00 a Year in Advance. Foreign Subscription \$1.52

VOL. V. CHICAGO, DECEMBER, 1895. NO. 10.

## CONTENTS.

EDITORIAL.....	163
PRACTICAL WORK IN THE CEMETERY.....	164
LICHEN AND MOSSES.....	165
*TREES IN TOWER GROVE PARK, ST. LOUIS, MO.....	166
*GARDEN PLANTS—THEIR GEOGRAPHY II.....	168
*THE GREENWOOD CEMETERY, BROOKLYN.....	170
*SCULPTURED MONUMENTS OF PHILADELPHIA.....	172
*NOTES ON ENGLISH PARKS.....	174
CITY PARKS.....	175
PARK NOTES.....	177
CEMETERY NOTES.....	178
CORRESPONDENCE—CEMETERY REPORTS.....	179
SEASONABLE HINTS—PUBLISHER'S DEPARTMENT.....	180

\*Illustrated.

QUITE an oversight in our park management, generally speaking, is that in regard to not labelling the trees, and as good a time as any to undertake the work is the winter. Most of the parks of the country contain many varieties of trees, with numbers of fine specimens, which would be object lessons to young and old, were it but possible to associate the physical characteristics displayed with the name and class. And this is especially desirable for city children. Country children grow up among trees; they are familiar with their properties and uses from very early days, and gradually and naturally absorb a knowledge of woodcraft incomprehensible to their city brethren. And the knowledge of trees and tree life is of far more value from an educational standpoint than is realized, and is becoming more so year by year. The little botany acquired in the public school could be made of permanent value reinforced by practical illustrations in the parks, and it is unquestionably of great importance that park commissioners everywhere should make it a special duty to permanently, plainly and lucidly label the trees under their care

by virtue of their office. Give the boys and girls an additional interest in the parks by making them educational while truly recreative.

THE Secretary of War has suggested in his annual report that Congress should adopt a fixed policy in regard to battle-field parks, for if the plan of creating military parks is to be carried out on the scale of Gettysburg and Chickamauga, some fifty places would present themselves for treatment involving an enormous outlay. It is true that while the liberal policy of the government, as displayed at the above named fields, has developed agitation favoring extension of the scheme to other important battle-fields of the civil war, it may also be predicted that the good sense of Congress will not be carried away into extravagance in this direction. In every battle-field is centered a vast amount of general and particular interest, due to causes readily understood, and it is natural to expect that particular interests will be very active toward distinguishing particular fields; yet to meet every case would not only detract from the value of the original design, but would involve so great an expenditure as to invite serious opposition and a possible obstacle to the proper completion of the work already under way. The question of partiality does not enter into the matter; the idea now being worked out is to preserve for future generations such military object lessons of the great contest as not only present lessons of military strategy, but pivotal points in the history of that contest by which the great historical features may be more readily correlated. It may be truly said that no amount of expense is too great to establish history, but there is a point even in this beyond which it will be unwise and unnecessary to go.

IT is very gratifying to note the steady increase in the number of memorial gifts to our cemeteries. This journal has frequently felt called upon to suggest that cemetery memorials need not be confined to the conventional mortuary monument, but could find a more Christian-like expression in some form, which, while dedicated to the memory of the dead might be of service to the living, thus giving a broader field to the sentiment conveyed by the memorial. Many forms of useful adjuncts to the cemetery have been suggested, that would fittingly serve the purpose, but donations of money for improvements and perpetual care have not been given the attention the beneficence warrants. Some



instances have occurred which draws attention to the possibility of making such gifts the means of perpetuating the memory of the departed in a broad and permanent fashion. In one case a water supply has been provided, and a stone structure in connection therewith serves to emphasize and make of permanent record the gift. In another case a donation has been left, the income from which after caring for the lot of the donor is to be devoted to the general care of the cemetery. These benefactions carry with them lively suggestions, on which could be founded memorials which would speak all the life of the cemetery and attract the gratitude and respect of many generations.

**T**HE death of the noted landscape architect, Calvert Vaux, which occurred under such sad circumstances the latter end of last month, was a shock to all who knew him personally. His body was found floating on the water at Bath Beach, N. Y., near the home of his son, with whom he was staying; and it is probable that in a moment of unconsciousness he must have fallen off one of the small piers in the vicinity. He was seventy-one years of age and had been in feeble health for some time. Calvert Vaux was a remarkable man, and had advanced knowledge in his chosen calling in no small degree. He was born in London, England, December 20, 1824, was educated at the Merchant Tailor's School, and then took up the study of architecture. Coming to this country, at twenty-four years of age, he was engaged by Andrew Jackson Downing to take the architectural part of the work of American landscape gardening, of which Mr. Downing was easily the founder. The firm of Downing & Vaux became celebrated. Its name has been prominently associated with the grounds of the Capitol and Smithsonian Institution at Washington, besides numberless other works of greater or less magnitude. Central Park, New York Prospect Park, Brooklyn, Chicago, Buffalo, Niagara Falls, and many places bear witness to Mr. Vaux's professional ability. He was a most energetic and industrious man, continuing at work associated with his son and other partners, until his sad departure.

#### Practical Work in the Cemetery.

In the recent convention of the Association of American Cemetery Superintendents held in Richmond, Va., and as a fact at all its conventions, perhaps the most valuable features have been the discussions of practical matters connected with cemetery work. With superintendents from all over the country, it is certain that a discussion on any subject will present a diversity of practice, from which, however, much information can be gathered and

from which also can be generally obtained some idea of the practice most likely to be the best under ordinary conditions.

In the recent meeting, following a paper on "Road Drainage," a discussion ensued on the jointing of the pipes, hinging principally on whether it were best to use cement for making the joints. The concensus of opinion showed a decided advantage, as to permanence and security, in favor of the cement jointed pipes. But the practice was varied, traceable to both experience and lack of experience, as well as to the variable conditions attaching to the work to be prosecuted. Then, too, the questions of soils, climate, lay of the land and individual knowledge were potent factors in the results obtained. Many of the experiences were interesting. Where the joints had not been made of a permanent material, pipes were frequently found choked with tree roots, though not in all cases, the soil appearing to have much to do with whether the roots concentrated an attack on the pipe joint or kept to the soil in preference. Another experience was that in passing through a short stretch of quicksand the sand crept through the pipe joints to such an extent as to choke the pipe for a long distance beyond it. The practice in another cemetery was to make cement joints on the main drains, but not on the laterals, a better drainage being secured and no trouble had been experienced from dirt or roots for many years.

One evil arising from uncemented joints was that the water would escape from the joint, and in its working around presently displace the pipe altogether. In certain soils this would surely result, as well as under certain conditions of grade and careless workmanship.

Even in clay joints in many recorded experiences tree roots had worked out the clay and found their way into the pipes to the utter demoralization of the drainage. The trees most given to pushing their roots into the drains are the Willow and Elm, though, as has been said, soil has much to do with their persistency in this direction.

There is no question but that all such work as the main drains of a cemetery should be carried out from the first with a view to permanent results; in which case as much care is necessary, both as to design, workmanship and materials, as is required in sewer work anywhere. Strict supervision is certainly called for in laying sewer pipe, the short lengths requiring absolutely good work to make such a sewer perfectly satisfactory. Where the grades are light, with a consequent limited speed of flow, the best of conditions, both as to quality of pipe, laying and jointing must prevail to prevent obstructions from accumulations of sediment. The



question of friction in the pipe is also an important one where the grade is very light.

Considerable knowledge of engineering is necessary in the general improvement work of cemeteries, especially in the larger ones, and many well known superintendents have affiliations with that profession. But where this is lacking and in the matter of constructing drainage, it might be well to suggest to superintendents to procure specifications of some system of pipe sewerage and glean therefrom all the available information on the subject of workmanship applicable to the case in hand. Access to such specifications can be usually had in the city hall of any town where any public improvements are contemplated or have been carried out.

---

#### Lichen and Mosses.

We have found beauty in the tree yielding fruit, and in the herb yielding seed. How of the herb yielding *no* seed, the fruitless, flowerless lichen of the rock? (The reader must remember always that my work is concerning the aspects of things only:—of course a lichen has seeds just as other plants have, but not effectually or visibly for man.) Lichen, and mosses, though these last in their luxuriance are deep and rich as herbage, yet both for the most part humblest of the green things that live,—how of these? Meek creatures! the first mercy of the earth, veiling with hushed softness its dintless rocks; creatures full of pity, covering with strange and tender honor the scarred disgrace of ruin,—laying quiet finger on the trembling stones, to teach them rest. No words that I know of, will say what these mosses are. None are delicate enough, none perfect enough, none rich enough. How is one to tell of the rounded bosses of furred and beaming green,—the starred divisions of rubied bloom, fine-filmed, as if the Rock Spirits could spin porphyry as we do glass,—the traceries of intricate silver, and fringes of amber, lustrous, arborescent, burnished through every fibre into fitful brightness and glossy traverses of silken change, yet all subdued and pensive, and framed for simplest, sweetest offices of grace. They will not be gathered, like the flowers, for chaplet or love token; but of these the wild bird will make its nest, and the wearied child his pillow.

And, as the earth's first mercy, so they are its last gift to us. When all other service is vain, from plant and tree, the soft mosses and gray lichen take up their watch by the headstone. The woods, the blossoms, the gift bearing grasses, have done their parts for a time, but these do service for ever. Trees for the builders yard, flowers for the bride's

chamber, corn for the granary, moss for the grave.

Yet as in one sense the humblest in another they are the most honored of the earth-children. Unfading as motionless, the worm frets them not, and the autumn wastes not. Strong in lowliness, they neither blanch in heat nor pine in frost. To them, slow-fingered, constant-hearted, is entrusted the weaving of the dark eternal tapestries of the hills; to them slow-pencilled, iris-dyed, the tender framing of their endless imagery. Sharing the stillness of the unimpassioned rock, they share also its endurance; and while the winds of departing spring scatter the white hawthorn blossoms like drifted snow, and summer dims on the parched meadow the drooping of its cowslip-gold,—far above, among the mountains, the silver lichen-spots rest, star-like, on the stone; and the gathering orange-stain upon the edge of yonder western peak reflects the sunsets of a thousand years.

\* \* \*

I never have had time to examine and throw into classes the varieties of the mosses which grow on the two kinds of rock, nor have I been able to ascertain whether there are really numerous differences between the species, or whether they only grow more luxuriantly on the crystallines than on the coherents. But this is certain, that on the broken rocks of the foreground in the crystalline groups the mosses seem to set themselves consentfully and deliberately to the task of producing the most exquisite harmonies of color in their power. They will not conceal the form of the rock, but will gather over it in little brown bosses, like small cushions of velvet made of mixed threads of dark ruby silk and gold, rounded over more subdued films of white and grey, with lightly crisped and curled edges like hoar frost on fallen leaves, and minute clusters of upright orange stalks with pointed caps, and fibres of deep green, and gold, and faint purple passing into black, all woven together, and following with unimaginable fineness of gentle growth the undulation of the stone they cherish, until it is charged with color so that it can receive no more; and instead of looking rugged, or cold or stern, as any thing that a rock is held to be at heart, it seems to be clothed with a soft, dark leopard skin, embroidered with arabesque of purple and silver. But in the lower ranges this is not so. The mosses grow in more independent spots, not in such a clinging and tender way over the whole surface; the lichens are far poorer and fewer; and the color of the stone itself is seen more frequently; altered, if at all, only into a little chiller grey than when it is freshly broken. So that a limestone landscape is apt to be dull and cold in general tone, with some aspect even of barrenness.—*John Ruskin.*



### Trees in Tower Grove Park, St. Louis, Mo.

Tower Grove Park is notable for its trees. There are probably more species represented and fine specimens of a greater number of varieties than any other park in the United States can show.

Henry Shaw, the founder of Shaw's Garden, now known as the Missouri Botanical Garden, presented



LIQUIDAMBER OR SWEET GUM.—*Styraciflua*.

this park to the city in 1867, and he not only designed the original improvements and planting, but was in active control of all that were added up to the time of his death in 1889 at the age of nearly 90 years. The knowledge of trees gained by him from experiments made in the Arboretum connected with the garden, was of great help in selecting trees for the park, which was originally a treeless tract.

Mr. James Gurney, who was then, as now, head gardener at the Botanical Garden, has, since Mr. Shaw's death, been superintendent of the park, and that no man is better fitted to talk of trees is shown by the rapid growth and symmetrical, yet free development of the vast number of those contained in the park, for they have been in his care from the outset.

The tree growths are such that quite apart from its beauty the sylvia of the park is valuable as illustrating the size, habit and qualities of trees best adapted to the St. Louis climate. Indeed, any one interested in tree culture generally may get many useful facts and suggestions from an examination of the specimens and results to be seen here. The trees in the original plantings were set singly, in groups and in lines—the principal criticism that landscape gardeners of the present are likely to make is that rather too many were set in lines.

Both coniferous and deciduous trees are used, and many fine contrasts of form and tint are seen.

Dark foliage of Ash and Elm trees are relieved by the paler green of the Sycamore and Maple, there being some remarkably fine Norway Maples among the numerous varieties grown. Broad leaved sorts, such as the Cucumber and Tulip, are offset by feathery Cypress and graceful Birch; and as a contrast to the many round-headed and broad-topped trees, such as Liquidamber, Magnolias, Linden, English Elm, many varieties of Oak and others, there rises at appropriate points the trim spire of various Cypresses, an occasional Lombardy Poplar and that other and more desirable fastigate tree, the Japanese Gingko, than which no tree is more attractive in its way. Indeed, personally, I find the unusual shape of the leaves, and especially the fantastic form of the female Gingko tree, quite Japanese and as fascinating as the Bronzes, Porcelains, Lacquers, flowers and people from quaint Japan.

The park is rich in Oaks, many varieties being represented; also in Magnolias, every kind excepting the tender *M. Grandiflora*, thriving well. And a magnificent showing is made of such trees as the Kentucky Coffee, English and Scotch Elm, Sweet Gum, European Ash and Linden, Buckeye, Yellowwood and Tulip. Tulip trees are numerous and when thickly covered in their season with yellow cup-shaped flowers are a beautiful sight. The Yellowwoods, too, when in blossom, are wonderfully attractive and one questions why they are so seldom seen.

It is found here that European trees are driving out those of native growth. They seem better able to withstand disease and the attacks of insects. Many native varieties are being yearly turned out to make room or give place to their more vigorous foreign relatives.

The English Elm and European Ash do far better than the American Elm and Ash and this is true all along the line. The one feature in the care of the park trees that is most noticeable is

Dark foliage of Ash and Elm trees are relieved by the paler green of the Sycamore and Maple, there being some remarkably fine Norway Maples among the numerous varieties grown. Broad leaved sorts, such as the Cucumber and Tulip, are offset by feathery Cypress and graceful Birch; and as a contrast to the many round-headed and broad-topped trees, such as Liquidamber, Magnolias, Linden, English Elm, many varieties of Oak and others, there rises at appropriate points the trim spire of various Cypresses, an occasional Lombardy Poplar and that other and more desirable fastigate tree, the Japanese Gingko, than which no tree is more attractive in its way. Indeed, personally, I find the unusual shape of the leaves, and especially the fantastic form of the female Gingko tree, quite Japanese and as fascinating as the Bronzes, Porcelains, Lacquers, flowers and people from quaint Japan.



THE GINKGO.



the close when young and ruthlessly removing any un- that shows a tend- strip its comrades. characterizes such spurious or robber make a great show- pense of the rest of that should be cut sult is free, even ing the character of men and making plantations of sym- developed trees that ure to look at.



watch kept over them to the end of noting ly removing any un- that shows a tend- strip its comrades. characterizes such spurious or robber make a great show- pense of the rest of that should be cut sult is free, even ing the character of men and making plantations of sym- developed trees that ure to look at.



CYPRESS.—*Glyptostrobus pendula*.

The illustrations shown from photographs of trees standing in the park include a Japanese Ginkgo, a Liquidamber and a Cypress. That of the Ginkgo shows the female form and admirably depicts its characteristic peculiarity of erratic growth. It is a tree that is well adapted to park planting, being hardy, yet able to thrive in a warm climate, adapting itself to either damp or dry soil, and is free from disease and insect enemies. It is an excellent choice for any position where a Lombardy Poplar would look well, and it may well replace that species, being a longer lived and much more attractive tree. The male Ginkgo is strictly fastigate and strongly resembles in general outline a Lombardy Poplar, although wearing its odd foliage in a way that distinguishes it from that variety to any one familiar with both trees.

The Liquidamber *styraciflua*, or Sweet Gum, a variety that is perfectly hardy at St. Louis, a very handsome tree at all times with its distinct foliage and symmetrical form, and really glorious when it takes on its fall garment of crimson, orange and gold. It is peculiarly free from insects and disease.

The fine specimen of that tree so infrequently seen as to seem rare, Cypress *glyptostrobus pendula*, closely allied to the somewhat better known *Taxodium distichum*, or deciduous Cypress of the south. This is one of two specimens of especially regular form that fit well in the landscape where they are placed. They stand on either side of a formal approach to a sheet of water from which rises a misty spray and across which can be seen artificial ruins built of stone taken from the old Lindell Hotel that burned some twenty or more years ago. The tall slender spires of plummy green accent the formality of the approach and add greatly to its dignity and beauty. In direct contrast to their slender columns stand specimens of Weeping Mulberry. Looking at these two and many other varieties seen, one can but marvel at the varied forms taken by trees alone without noticing shrubs, plants or flowers. They are of endless interest. One grows more and more to feel that the only way to keep up a perennial interest in life throughout our allotted space is to cultivate a love and interest in the only things in the world that are continually renewing their youth, or at least taking a fresh start each year after a season of hibernation, during which one easily fancies the big, sturdy trees, little dry bulbs, almost obliterated plants and wholly invisible roots to be quietly thinking things over and getting what the children call "a real good ready" before making a fresh start in life. It does make one somewhat envious at times to see them start off anew with the old record wiped out, while we— but in the main it is about the best interest, study, work and pleasure the world has to offer up to date.

*Fanny Copley Seavey.*

Amateurs and others frequently try their hand, at producing blue flowers from varieties that do not include that color in their nature. In relation to that the *St. Louis Republic* makes the following remarks, which may serve as a reminder: A knowledge of one simple law in nature may save the flower-grower days and weeks of hard and unavailing labor in attempting to produce that famous chimera of the botanists—the blue rose. The law is simply this: The three colors, red, blue and yellow, never all appear in the same species of flowers; any two may exist, but never the third. Thus we have red and yellow roses, but no blue; red and blue verbenas, but no yellow; yellow and blue in the various members of the violet family, but no red. Other examples of this rigid law could be cited, but the above are sufficient. The botanist or floriculturist who really understands his business never attempts to produce a blue rose or a red violet.



## Garden Plants,—Their Geography.—II.

## RANALES. (Continued.)

A tropical order, with 200 species, follows here and then the *Calycanthus* "shrub," with 3 species well known, and *Chimonanthus*, with 2 species, which are tender north of Washington. They are beautifully fragrant in a cool greenhouse during the early months of the year. The *C. fragrans grandiflorus* is best. The flowers are small, yellowish and inconspicuous.

*Cercidiphyllum Japonicum* is a comparatively new tree. It has heart-shaped leaves and inconspicuous flowers. It attains a large size in Japanese forests and promises well here. It is quite hardy in New England and is well worth trial for its unique appearance.



CHIMONANTHUS FRAGRANS.

*Magnolia* is a genus of American, Himalayan and East African trees and shrubs in 15 species and many varieties. They are both evergreen and deciduous. Scarcely any trees excel them in beauty and grandeur, and none are finer than the *M. grandiflora* of the south. This splendid evergreen is used as a wall plant in England, in which position it often clothes the fronts of houses with surpassing beauty and produces its magnificent fragrant white flower, from 8 inches to 1 foot in diameter, in abundance. I have seen but one plant in a similar position at the North, but that one abundantly proved its adaptability for walls from the Carolinas to New York. It is strange that with the scarcity of evergreens with broad leaves northern gardeners should neglect so fine a subject when it may so evidently be easily grown and preserved on an east or north wall. Through New Jersey the leaves are scorched in hard winters, but it easily repairs the damage. *M. macrophylla* is also a splendid species, with immense deciduous leaves and flowers even larger than the *M. grandiflora*. Most of the American species flower after the leaves are produced; most of the Asiatic kinds produce theirs before the leaves. The magnificent

*M. Campbellii*, from the Himalaya, is exceedingly rare in cultivation, indeed, I am not aware of a plant



MAGNOLIA CONSPICUA.

in this country. It will probably be tender north of Richmond, Va.? Magnolias are difficult to move. They have done best with me after the growth has started and when cut hard back.

*Liriodendron* is our "tulip tree." There is but one, unless, indeed, North Japan should reveal another. It is one of the most magnificent trees in existence, but is rarely seen at its best. The branches should sweep a lawn if its noble proportions are wished to be seen in perfect development. I have seen larger, but never more beautiful specimens than the large ones near the Brentford Gate at Kew Gardens, London. It is best transplanted in spring.

*Schizandra* has 6 species from the mountains and tropical parts of Asia and from North America. Our kind, *S. coccinea*, is a climber not very often seen.

*Asimina triloba* is another monotypic species so far as this country goes. There are five or six others in Central America and the West Indies. Our plant is a true representative of the tropical "custard apples," and its misleading common name in the United States should be dropped. It leads authors into bad mistakes. The fruit is really very good, and I am glad to know that good kinds are being selected.

*Cocculus*, with 10 species, and the "Moonseed," *Menispermum*, with 2 species, are both represented in gardens by native climbers of merit.

*Akebia*, with 4 species from China and Japan, is represented in our gardens by *A. quinata*, a pretty shrubby climber with very fragrant, but modest



purplish-brown flowers. Southwards this is nearly evergreen.

*Berberis* is a large genus of 60 or more species, some evergreen and many deciduous shrubs. They are very ornamental in flower and fruit. They are distributed widely in Europe, Asia and America. The evergreens are fine under light shade.

*Epimedium*, "Barren Worts," have 9 or more herbaceous species, *E. macranthum*, from Japan, being one of the best. The species are found in Europe, Asia and Algeria. They flower early and die down, sometimes flowering in autumn.

*Podophyllum peltatum* and *P. Emodi* are the only "May apples" known. The Himalayan one has bright red berries.

*Cabomba*, with 2 or 3 species, all American, and *Brassenia peltata*, with a very wide distribution over the American, Africa and Asiatic continents and also found in Cuba and Australia, is sometimes seen in collections of Water-lilies.

*Nuphar* has 3 or 4 species, all found in the Northern temperate zones.

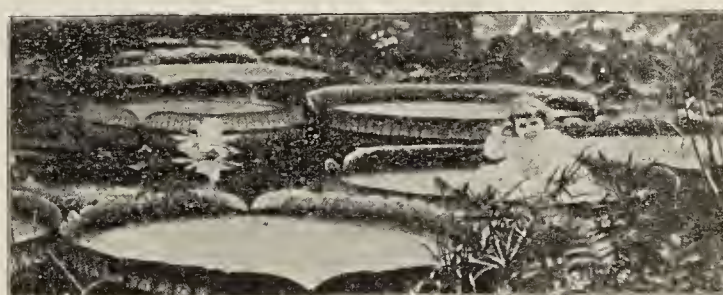
*Nymphaea* has 25 known good species and a large number of beautiful, natural and garden varieties. Recent additions have made it possible to represent all the colors except blue in the hardy water-lily pond, and as *N. scutifolia* is hardy south of Washington and a blue variety of *N. gracilis* has recently been rediscovered in Texas, it may be expected that blue will soon be added to the hardy kinds without waiting for Central Asia, which is pretty sure to produce one. A good way to manage the tender kinds is to plant them in baskets of wire, which are lighter than boxes or pots, and permit the roots to reach the mud of a pond more freely. A good list of day bloomers, *N. alba candidissima*, white; *N. X. Marliaca*, chrom yellow; *N. X. Marliaca*, rose; *N. scutifolia*, and the blue varieties of *N. gracilis*, Southwards.

The night blooming kinds are only known in red and white. *N. dentata gigantea*, white, and *N. Devonienis*, red, are as good as any. For their best development they require a tropical heat of 80 degrees in the water.

One of our growers ventured the opinion that these tropical night bloomers would not hybridize with the day bloomers; it has been done, however, I understand. The truth is, the time of blooming varies a good deal in the different countries, and we will soon have all the merits of a *Nymphaea* by daylight at the present rate of progress.

*Nelumbium* is given 2 species. I declare I hardly know why. There seems to be little between our native creamy one and the Asiatics, and I doubt *N. luteum* being a true native anyhow. It does not behave like one. Why is it found in such

wide apart isolated stations, and why so hard to establish north? I think some one has suggested in print that Indians carried it around. I believe they brought it across Behrings Straits as food. Any-way it may be duplicated in color in Asia, and it is curious that the yellow one alone should be found in America. It is now twenty years since I first directed attention to the probable hardihood of these splendid Asiatics, and although Saunders failed with his first seedlings through too early planting, and Buchanan, in 1881, through planting in a cold running stream, yet as others followed with more success I feel attention was not directed to them in vain, and the same may be said in the matter of growing the *Victoria regia* outdoors. Has any-



VICTORIA REGIA.

one tried to cross this with *Euryale ferox*? which is quite hardy south. Perhaps it might succeed, who knows?

Trenton, N. J.

James MacPherson.

GOOD GARDEN SOIL.—What is, or what is not good garden soil, is often a great question. The customer often complains to the nurserymen that, though he planted his trees in the very best soil, yet he had little success. Very few people seem to understand that good soil is one in which the atmosphere can freely circulate. The earth must not allow the air to circulate to such an extent as to lose its moisture; but it must have an abundance of small spaces which will contain small quantities of air before plants will thrive. We sometimes speak of "air plants," but in truth, all plants are air plants, no matter whether growing on rocks or trees, or whether growing in the earth. Air is of far more consequence to the roots than to the leaves. When, therefore, we have a stiff, clay earth to deal with, we make a good soil by applying sand, or vegetable matter which, when it roots will leave small spaces in which air may be collected. It is for the same reason that we crush hard clods, for a hard clod has no air spaces. When broken to pieces,—pulverizing is the technical term,—we simply give the chance for atmospheric air to spread throughout the whole mass. For the same reason, what is known as a wet soil is a bad soil, because water drives out the air."—*Mechans' Monthly* for December.



**The Greenwood Cemetery.**

BY WILLIAM HOWE DOWNES.

The most astonishing fact about the Greenwood Cemetery, in Brooklyn N. Y., is that between 1840 and 1892 the total number of interments was 268,786. If the ordinary or average number has not varied in the three years since 1892, the number of interments there up to the present time can not be far from 300,000. These statistics are surprising. The cemetery contains 474 acres of land. It has 22 miles of carriage roads and 18 miles of foot-paths. There are in the grounds no less than eight lakes, all of which have fountains; 2 reservoirs, 10 miles of water pipes, 62 hydrants and 19 miles of sewers. The estimated average of about 5,200 interments per annum would give us 100 funerals each week, or a little more than fourteen for each day in the week. These figures may serve to convey some idea of the enormous size and densely compacted population of this immense city of the dead.

The situation of Greenwood is most beautiful, and its contiguity to the two great cities of Brooklyn and New York affords the obvious geographical explanation of its exceptional growth. It is also to be remarked that it has been for half a century the most fashionable burial place for wealthy families, and the mysterious potency of fashion has as much to do with cemeteries as with anything else. Like all the best cemeteries in this country, Greenwood is well kept, carefully managed in the interests of the lot owners and abounds in costly monuments.

It is especially notable for the number of eminent individuals whose mortal remains are buried there. Although but few of these have a national reputation, the list of names of the dead would comprise a considerable number of widely known New York business men, inventors, professional luminaries, literary people, philanthropists, statesmen and

merchant princess of the metropolis. Some of the monuments erected comparatively early in the history of the grounds and costing vast sums would hardly be deemed works of art even in the estimation of the uncritical; for here, as elsewhere, mere size, weight and bulk, with expensiveness of material and occasionally fineness of workmanship and finish, have been blindly accepted as fulfilling the requirements of a memorial, without the most rudimentary effort to secure harmony of proportions, balance and symmetry of outlines and the first essentials of good design. On the other hand, the visitor who searches patiently will find certain tombs which produce an effect of reposeful dignity, of architectural impressiveness and even of sculptural grace and originality.

The principal gate, a monumental structure of dark brown sandstone in Gothic style at the Fifth Avenue and Twenty-fifth street entrance to the grounds, is exceedingly handsome. It is decorated in the recessed panels above the arched gateways with high-relief stone carvings representing the Entombment, the Resurrection, the Raising of the Widow's Son and the Raising of Lazarus. Near the gate is the receiving tomb, with a capacity of 1,500 in its extensive vaults excavated from a steep hillside; and just in front of it is the pretty sheet of water with the picturesque name of Arbor Water.

In the same vicinity is the rather ordinary monument erected by the city of New York in memory of the soldiers who died in the defense of the Union, 1871-65, a tall granite pillar of no particular style, with four bronze figures around the base typifying the various branches of the land and sea service, these statues being cast from the material of captured cannons. The summit of the hill on the slope of which this monument stands commands the finest view of New York harbor, Staten Island, and the Lower Bay, to be obtained anywhere. The vast city of Brooklyn stretches to the north until its roofs and spires are lost to view in the dim distance. The high buildings in the lower part of New York seem to rise almost beneath the spectator's feet. The stirring panorama of the swarming harbor and the crowded shipping of the East River, with the filmy outlines of the huge Brooklyn Bridge, form a superb spectacle of life and animation, and the western horizon is beautifully closed by the vague blue silhouette of the Orange mountains in New Jersey. All in all, this is the grandest prospect to be had in the neighborhood of New York, and it makes an impression of vitality and in-



ENTRANCE TO GREENWOOD CEMETERY, BROOKLYN, N. Y.





GREENWOOD CEMETERY—ONE OF THE LAKES.

tense activity which is only heightened by the contrast with the silent and peaceful alleys of the army of the dead.

Greenwood is singularly favored by nature, the ground being just sufficiently rolling and diversified by hills and vales to furnish forth a constant succession of gentle and sylvan scenes pleasantly shaded by large and healthy white oaks, which in some instances have reached an exceptional size. The lakes and fountains supply the needed element of water in the landscape, and in the summer the display of flowers is extensive and rich.

A melancholy interest is attached to the monument built by the city of Brooklyn to commemorate the 105 unidentified victims of the terrible Brooklyn Theatre fire of 1876—a calamity, the horrors of which are still remembered with a shudder.

An interesting and pathetic memorial is the Pilot's Monument, erected by the pilots of New York in memory of one of their fraternity who died heroically in the discharge of his duty in a shipwreck on the New Jersey coast in 1846. This monument is surrounded by emblematic carvings suitable to the nautical character of the pilot's career, and it is crowned by a statue of Hope. The situation of this memorial is on a hill-top overlooking the harbor, and it can be seen by every pilot who enters the bay.

Another interesting work associated with maritime life is the Old Sea Captain's Monument, as it is commonly called. This is the tomb of Capt. John Correja, a hardy ancient mariner, who built his own monument about fifteen years before he died. He had his own portrait statue carved in marble, and chose to be portrayed in the characteristic act of taking an observation of latitude and longitude. In the hands of the stone figure is the actual sextant used by the old man for many years.

He stands firmly on his short legs, intent upon his important and delicate task, in the everyday costume of a merchant ship master; there is to my mind a world of marine romance in the curious image of the quaint Sea Captain, long since embarked on his last voyage across uncharted seas of night.

But there is a peculiar sadness about the untimely death of the beautiful young girl, Charlotte Canda, that lovely maiden cut off in the flower of her innocent youth (she died on her 17th birthday, the victim of an accident), and whose heart has not been touched by the old story of her father's broken heart, and his expenditure of his whole fortune in the splendid monument of intricately carved Carrara marble, one of the renowned works of this famous cemetery? Its lace-like filigrees of finest meshes, its wonders of patient detail, its wealth of emblematic handiwork, are beautiful expressions of an undying paternal love. No one goes to Greenwood without visiting this shrine. No doubt the taste of the structure might be criticised, but to my apprehension all its convoluted and tangled webs of sculptured marble are sanctified by a sacred sentiment which renders it inviolable and exempt.

I own that the cheapest display of affection, if it be the real thing, disarms me completely as a critic. Cheapest, did I say? Let me retract that word. Affection is the one thing on earth which can not be that. I have found the meanest and lowliest of burial grounds to abound in that sweetest and divinest evidence of humanity's worthiness of immortality—the loyalty of the living! So eager should we be to foster the manifestations of this nobility, so tolerant should we be to see with complacency its clumsy and groping rituals and tokens, that I can almost venture to prophesy the coming of a time when our cemeteries will be the most beautiful places in the world and the most inspiring.



## Sculptured Monuments of Philadelphia,—III.

GEN. JOHN F. REYNOLDS.

This equestrian statue, which backs on the northern side of the City Hall and faces the long



GEN. JOHN F. REYNOLDS.—JOHN ROGERS, SC.

range of North Broad street, is an emanation from the hands of John Rogers, sculptor, New York, that versatile progenitor of parlor groups, historical and domestic subjects. What more needs be said? The character of his work is so broadly known that further comment on the man seems futile. Gen. J. F. Reynolds, it may be remembered, fell on the morning of the 1st day of July, 1864, as the advance was made by the union troops to intercept the flank of Gen. Lee's columns. Advancing towards McPherson's woods, at Gettysburg, Gen. Reynolds being foremost in the van, recognized too late that the guns of the confederates were already planted and trained upon them; raising his hand as a signal for the advance of his troops, the enemy fired and Reynolds fell mortally wounded. The sculptor's intent and purpose was to depict virtually this incident. Reynolds is in fatigue uniform, with field glasses slung over the shoulder, light sword and forage cap, reining in his horse, with the right hand raised at an angle of a few degrees above the shoulder's level.

\*The writer acknowledges with thanks the courtesy of Mr. C. H. Howell, Secretary of the Fairmount Park Art Association, in furnishing some of the data relative to the work of the Association.

The portraiture is reasonably good, the figure of the man, however, is bad, since the waist line is too short, rendering the sword belt conspicuously high from the saddle seat, making the body altogether too short from the shoulder to the waist and a long seat in the saddle, an impossibility to a man reining in a horse. This was, I believe, John Rogers's first and last equestrian statue.

The base of the pedestal, which is of Quincy granite, measures 14 by 9 feet, rising 8 feet 6 inches, the plinth being polished, rising from the ground 2 feet by 6 inches, the rest being unpolished. Bearing on the face, "Reynolds," "Sept, 21, 1820," "Sept. 18, 1884." The statue was practically the gift of Mr. Joseph Temple, for many years associated with the Academy of Fine Arts, Philadelphia, and a philanthropist. From a fund created during his life a medal and \$25,000 was given. The pedestal, costing \$6,000, was subscribed and paid for through the medium of the G. A. R. men. The casting was made by the well known Bureau Bros., Philadelphia.

## BARVE'S LION AND THE SERPENT.

Barye, the inimitable, is here represented and in a charming position, facing the north of Rittenhouse Square, surrounded by the best of Philadelphia's houses, in a good, clean, congenial and elevating atmosphere, the well-known group challenges the young and old alike, stimulating the young and causing the old to regard with envious eyes, the half-subdued, but reserved strength of the lion, as he half shyly casts his head to the onese, while still keeping his eyes upon the hissing and spitting



BARVE'S "LION AND THE SERPENT."

venom of the serpent. One can not regard the combatants long without realizing that the lion's heart would relent towards the half-subdued viper did it



but know enough to keep closed its mouth and thus silence its hissing. But, no; courage born of desperation loses discretion, and that lost, the foe becomes enraged, then relentless, and the tragedy becomes speedily final. In this group the lion—scarcely above life-size—is in all its proportions charming, even to a subtle delicacy in its graceful, life-like, sinewy strength, which emerges into the cunning half-shy movement of the eye, that regards so stealthfully the tortuous and hissing form of its victim—the serpent—writhing beneath the massive paw of its conqueror. This is mounted on Richmond, Virginia, granite base 8 by 4 feet, rising from the ground 3 feet 6 inches, unpolished and broad at the base, carved and hollowed center, with a polished crown mould. The cost to the association for the plaster cast and casting—which was executed in the foundry of F. Barbedienne, Paris, France, and pedestal amounted to \$3,111, and incidentals made a total of about \$5,500.

This may be accepted as one, if not the best, acquisition in the category of Philadelphia's statuary, and of which the Fairmount Park Art Association have every reason to be proud. The original stands in the Orangery in Paris, the resting place of Barye's lion, on the column of the Bastille and the companion monarch of the forest, which, I believe, stand at or near the bureau of the Prefecture of police, at the Palace of the Louvre.

Philadelphia also holds among the Wiltsbach collection at Memorial Hall, Fairmount Park, a bronze group, the "Eagle and Heron," another charming example of this great man's achievements.

#### THE LION FIGHTER.

Temporarily, this group stands near the northwest corner of General Post Office, Ninth and Chestnut street. This is a splendid replica of the original by the late Prof. Albert William Wolff of Berlin, Germany, a man thoroughly imbued with the exalted ideas consequent upon ambition, a broad mind and of independent and deliberate action, but yet not possessed of that rugged avidity and conception necessary to depict human or animal passion or rage, which develops into the full blown blossom termed despair.

Dealing more severely in the platonicisms of peace, he was regarded with due reverence by his fellow Teutons and honored by his King. Born in Neustrelitz, Mecklenburg, on the 11th of November, 1814, he, at the age of 17, entered the studio of Christian Rauch, and from him, who had caught the more peaceful-atmospheric-creative vein of Canova and Thorwaldsen, Wolff's life was shaped.

The touch and teaching of that school ended only with his death, which took place on the 20th of June, 1892.

His "Lion Tamer" rendered him, in a public sense, exalted, but among the many of his works sight must not be lost of the equestrian statues of Ernest Henry, King of Hanover, which proud and stately Hanover still guards, King Frederick William III in the Lust Garden of Berlin, King Frederick William IV. at Konigsberg, the charming figure of Peace at the foot of Rauch's Columns, crowned by his familiar Victory, are among the many creations which bear evidence to his signal and everlasting ability.

For many years the Fairmount Park Art Association made fruitless efforts to obtain the plaster cast of the group that forms this theme. Nor was it until Herr Mauger, a former student under Wolff, came to live in Philadelphia, that correspondence



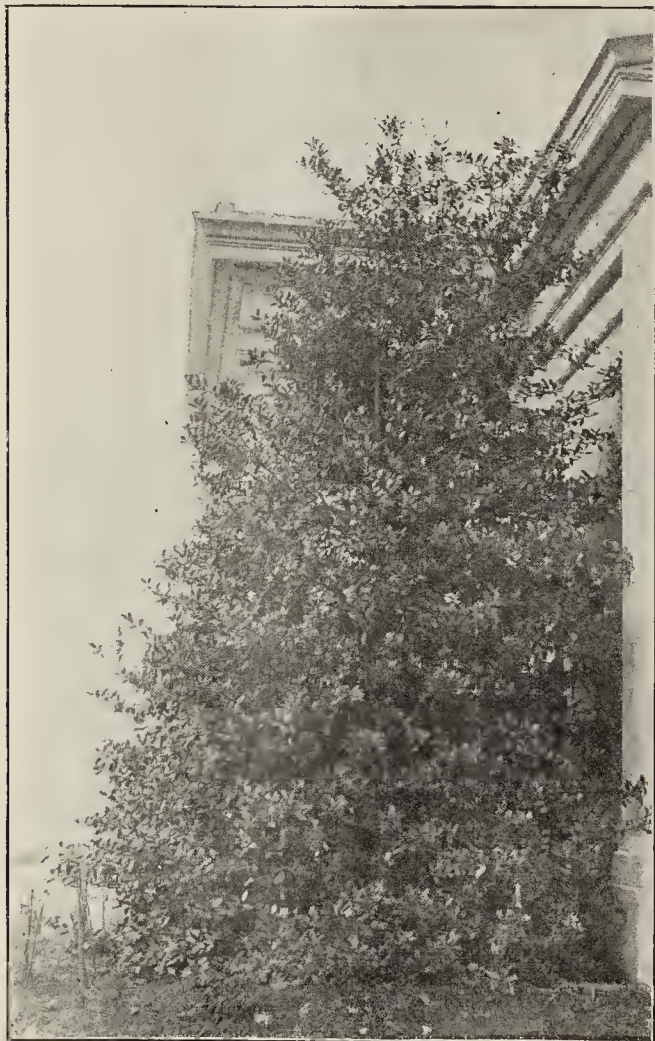
THE LION FIGHTER.—PROF. ALBERT WILLIAM WOLFF, SC.

was again opened, which resulted finally—owing to his efforts—in the Association obtaining the cast. The German government at first demurred, but finally consented to allow a recast to be made in plaster in the Government Atelier, for which a charge was made of \$1,500. Upon its delivery here it was turned over to Bureau Bros., by whom the casting was made at a cost of \$5,500. In the original the lion is placed hors de combat, with the broken spear-head driven well in, under the left breast. An accident to the plaster cast in shipment caused this to be broken off, and unwittingly this was omitted in the casting. This error will be rectified before it is set in its final resting place.—*W. Percy Lockington.*



## Notes on English Parks.

During my visit to England last summer I made it a point to visit all the parks, public and private grounds that were convenient and that I could gain admittance to. Arriving at Southampton on



HOLLY.—*Ilex aquifolium laurifolia*.

Wednesday evening, before leaving the town next morning, I took a walk through one of the parks, of which there are several there, and I find that by my note-book that the first thing that attracted my attention there was a fine Hawthorn, *Cratægus grandiflora*, the large white one. Hawthorns were yet in bloom, though it was the end of May. In the south of England, wherein is the town of Southampton, the varieties of Hawthorn are very much prized. Besides *grandiflora*, which has large white flowers, there is a single pink and a double rose variety much planted in England, and in this park were several of all these kinds and others, beautifully in bloom. I do not know why we do not grow these beauties more here. It is quite a mistake to suppose they won't grow here. At least, in Pennsylvania there is no trouble at all in growing them. The red flowered Horse Chestnut is a universal favorite, being seen everywhere, and making a fine round-headed tree, and having leaves of lus-

trous green color. It was in splendid bloom. To have the best success with Horse Chestnuts here, they need to be planted in deep soil. When the roots penetrate to a good depth they appear to hold their leaves better in the summer. Besides the red flowered there was an avenue of the common one, and these, too, were in full flower. We think our winters trying on rhododendrons and similar evergreens, and so they are, but we are not alone in thus catching it. The rhododendrons in this park were, many of them, dead, and all showed foliage more or less injured. Among bays, laurels, aucubas, euonymus and similar broad leaved evergreens, all showing more or less injury caused by the winter, a notable exception was the Japanese broad leaved evergreen, *Photinia serrilata*, so admirably had it stood, where even *Magnolia grandiflora* had been hurt, that I am nearly sure that this would prove hardy, say from Philadelphia southward. Later on, in July, I saw it again, the picture of a beautiful shrub. The Portugal laurel, *Cerasus lusitanicus*, was also in an unhurt condition, and a variety of it, *pyramidalis*, is said to be hardier than the parent form. There were signs of injury on many trees usually deemed entirely hardy. I am satisfied that were we to plant more in masses, as the English do, we could have lots of nice things which we now deem tender. I have seen living out in Philadelphia *ancuba Japonica*, *Azalea Indica*, *Magnolia grandiflora*, *Ilex cornuta*, *Eleagnus pungens* and similiar things, deemed tender by most persons. We want more shelter belts and close planting about our favorites, then they would survive. There were in this park some fine specimens of the *Ilex aquifolium laurifolia*, known as the entire-leaved holly. This reminds me to say that, contrary to the general opinion, this holly will thrive here. As a proof of it, I submit a photograph of a fine branch of it growing in the Drexel lot, at Woodlands Cemetery, Philadelphia. This plant is fifteen feet high and some eight feet wide at the base, and, being of luxuriant growth, dark green leaves and almost spineless, it attracts universal attention. And in Laurel Hill cemetery there is one of the common form which has flourished for years, even in the severest weather. The variegated and golden leaved hollies are prominent in all the parks of England. A mile or two outside of Southampton is a large public common, kept up in good condition, and patronized all the time by the public. There seems less desire to have flowers and shrubs than to have a place where children, and grown up persons, too, for the matter of that, can romp and play and enjoy themselves on the grass. Everything invites you to get on the grass and nothing tells you to keep off it. On this common I saw, and for the



first time, the English holly in its wild state, in great abundance. And, though not for the first time, lots of Scotch heath, *Calluna vulgaris*, and I am told that not far away inland the English Yew can also be seen in its primitive state. I saw this common and the parks spoken of twice during my stay in England, and on each occasion on every hand were to be seen the public enjoying themselves in them.

*Joseph Meehan.*

#### City Parks.

The following paper on "City Parks" was recently read before the Municipal League, Topeka, Kansas, by Mr. E. Wilder, secretary and treasurer of the A. T. & S-F. R. R. Co. Although written for local purposes, there is very much of value on the general question, and beyond eliminating purely local matter, the paper is presented in full:

Let me premise by a declaration that probably any thought I may utter on this subject, has already been expressed in better form in some of the numerous books or magazine articles of the last twenty years.

Originality of thought or expression in these days of intense literary activity and special research, cannot be hoped for with any degree of confidence, even by those who are able to devote much time to a chosen line.

The average busy man of today can only justify his appearance in print by a wholesome personal desire to broaden his own view, and compel his own thought into orderly channels, by subjecting them to the test of public criticism, encouraged in his sacrificial progress by the hope that as *all* cannot read *all* the books, magazines and papers that are printed, perhaps he may innocently enjoy the pleasure of being to some a first or new acquaintance. If I am fortunate enough to present any truth, in a new light, or lead to a new thought on an old truth, I shall feel satisfied.

Truth is of Divine origin—it is infinite. It was, it is co-existent with God the Creator. It governs the expression of the infinite love in its infinite variety of manifestation toward his creatures.

Should we not then, reverently put aside all gross material aims or ambitions in the contemplation of public improvements, which unfortunately are not always, but always should be, the highest possible expression of the highest and purest thought of the community, the embodiment of good-will to the neighbor, not for this present generation only, but for the longest possible future. Hasty, immature plans—cheap, inartistic work—jobbery and fraud, ought not to be the measure of our expression in public works.

It is often said that public parks are the lungs of a great city, the breathing place of the multitude; and the enormous sums expended in New York, Boston, Philadelphia, Baltimore, Chicago, St. Louis and many lesser cities, in the acquirement and adornment of public parks, indicates a confident belief in the efficacy and importance of the public lungs to the general health, which bids fair to far exceed the attention given by many individuals, until too late, to one of their most important organs.

Is the breathing spot, however, the important feature? Is the mere physical openness the object of all this expenditure? Would a vacant block in the squalid portion of one of our great cities, littered with tin cans and healthy rubbish only, meet the essential needs of the poor? True, the fresher air thus obtain-

able, would doubtless be a relief occasionally from the close atmosphere of narrow streets and crowded courts: but the benefit would be merely physical, and while sound healthy bodies are extremely desirable as a foundation, we ought to, indeed we must, recognize that the higher mental, moral and spiritual development of the community is the supreme object. Fresh air and good lungs are important aids, they are not ends. Why have millions of money been spent in Central Park, New York, and the miles of boulevards and parks stretching out from Boston, where the rich and poor may equally enjoy the beautiful roads and walks, the endless variety of tree and shrub, the exquisitely kept lawns, flowers of rarest hues, and unique architectural effects?

What is the effect upon the civic life and character? Dismissing from our minds with some feeling of shame, the corruption and selfishness that have been incidents, certainly not ends, in some of these noble works, I think we may safely believe that even the luxurious, wealthy class, finds beneficent effects and impulses from this closer contact with nature, this contact with beautiful forms and colors, this change from even their supposedly agreeable daily surroundings and duties.

How much more important, then, are these influences to the middle and poorer classes, whose limited means preclude the acquisition and enjoyment of personal surroundings of elegance, refinement and beauty, and whose daily lives are so filled with toil and anxiety that they have no time or heart to plan for and accomplish the education of their higher faculties, the uplifting of their natures above the merely physical plane.

The weary progress through centuries, from a semi-barbarism which recognized only force or power as the measure of the respect of the individual for the property rights of his neighbor, to the Christian civilization of our day, need not discourage us in the effort to attain the still distant level of a willing respect for the rights of ownership of flowers and shrubs which others have planted, and we may even, in time, create a public sentiment against the unsightly cross-cut paths over our street-parks.

One of the saddest features of our human experience is the ease with which we drop down in our standards or levels unless we are vigorously fighting for a perceptible advance.

I have alluded to the effect of parks upon the moral and mental tone of the community. The influence upon the artistic side of our nature is too evident to need mention. Let me explain why I lay such stress upon the moral and mental influence.

If a wallet with money is left in the house and is stolen by a tramp, we do not hesitate to name the crime and punish the offender. If the wallet is left out on the horse block or on the sidewalk and is picked up and kept by a stranger, we may still call it stealing, but the sin seems to be mitigated because of the money having been placed carelessly in an improper place. The stranger takes what does not belong to him and avoids any effort to find the owner by enquiring at the house in front of which it was found, or elsewhere.

Parents would not fail to warn their children of the evils of house-robbing. They are not all careful to instil into the childish mind the honesty of trying to restore to the owner something he has lost.

Now, let us suppose that instead of leaving money in a wallet in the house, it is expended on plants for the yard to furnish a charming bit of color, not only for the owner, but for all who pass; or the money is expended on a fine sod in the park outside of the walk. These are not actual money, but they have cost the money, and it will require the expenditure of more money to replace plants stolen from their beds, or sod worn out by youths and even by adults taking "a short cut," as though their time was very valuable per minute.

What is the difference morally between the last instance and the first? The contributory negligence of the second case



cannot be applied to third instance as plants and lawns are in their proper places. There would be hesitation in burning down your neighbor's house or barn. Why should we in cold blood, or thoughtlessly, destroy or damage something equally dear to him, and not insurable? How many parents ever inculcate in their growing families this form of love to the neighbor, this willing respect for his property rights in small as well as in large matters?

If, as I hold, the injury to or destruction of that which our neighbor has created for use or pleasure, is very close to those grosser forms of dishonesty whose characterization and punishment are not in doubt, is not anything which will enforce a higher standard of action, and anything which will enable us to think more clearly and honestly, a factor worth considering as a moral and mental power?

We think very loosely, indeed many of us do not think at all, on *our duties* and *our neighbors' rights*. It is so much easier, so much pleasanter, so infinitely more in keeping with tradition and example, to dwell upon *our rights* and *our neighbors' duties*.

It is difficult to decide whether thoughtless action promotes careless, evil thought, or whether it is careless thought which is responsible for much evil action. Doubtless both suggestions are true; and it behooves us to encourage ourselves and others, especially our children, to think naturally and easily in right lines, and avoid setting an example in act for thoughtless imitation, in the small things of life, in order that as the larger questions have to be met, there will be a strong and safe foundation of natural impulse for the right.

As a public park is the common property of all, each citizen having a direct property right in its treasures of flower and shrub and tree, it would seem only natural that a strong public sentiment should successfully protect them from mutilation and destruction. This is the result in time; but a serious struggle with innate vandalism is the usual early experience in most park efforts. This spirit of vandalism, this wanton disregard of the rights of the neighbor, which is so difficult to combat when you are at the disadvantage of having a personal interest as a victim, can be best met and vanquished, when it is not a question of individual suffering, but when every protest is the voice of the many against the few.

In time a correct moral sentiment is evolved from an era of efficient police protection.

When we have acquired a taste for this form of Christianity, we shall be able to remove the unsightly, but still necessary, park railings from our home grounds, and shall not be compelled to resort to special devices to protect the corners of our lawns, and our public park expenditures will have been justified.

Do you say this is trivial—this is wasting time and energy upon insignificant details—what has all this to do with city parks in general, and the needs and possibilities in Topeka for more or better parks?

I reply the connection is logical and vital.

It is the little things that make up life—it is the careful attention to detail that secures the most harmonious results. How often we see the entire effect of a handsome house marred by an inharmonious or defective fence or wall, or by grounds, the care of which stopped at the side-walk instead of reaching out to the street—or by a rough unkempt gutter bounding a well kept park lawn. A clean cut edge enhances very materially a beautiful grass plat. An ill kept park will bring the house and grounds down to its level. While the tail does not generally waggle the dog, the narrow rudder does govern the direction of the longest steamship, and the untidy feature of a property or a landscape will catch and hold the attention to the serious detriment of the whole.

Until we instinctively confine ourselves to the regular side-

walks, cross-walks and streets, we are hardly fit to thoroughly enjoy and properly use a beautiful public park.

Could anything be more delightful than a drive in the fresh morning air, or after a hot day's work, over a good park road by the river and under beautiful trees. Would not the cyclists rise up as one man (and one woman) and call us blessed. Could we do better for our young people or for ourselves, or for future generations than to provide for this frequent touch with nature—this getting away from the brick and mortar and asphalt of our daily lives.

Do not let us be discouraged by any seeming magnitude or hopelessness of the undertaking. Let us set a high ideal, and reach it as nearly as possible, in time—perhaps not fully in your day or mine. We can at least make a good beginning and can lift ourselves onto higher levels of life and thought by the effort.

I shall not attempt to discuss tonight the legal, financial, practical details. They will be worked out in due time when a public sentiment shall make the demand.

Much of the labor required will be of the unskilled kind and there will be opportunity to relieve the community of the care of the unfortunates who are willing and able to work but for whom there have been no employers.

We need as a community, some strong, common incentive, something outside of our selfish personal interests, some work in which each will feel a powerful individual interest, not because of any selfish gain but because of the good to all.



Fountain presented to the town of Great Barrington, Mass., by Col. William L. Brown of New York.



## PARK NOTES.

Quite a number of native wild animals have been secured for the "Zoo" department of Schenley Park, Pittsburgh, Pa. They were collected by the Eaton Bros., of Custer Trail ranch, Medora, N. D.

\* \* \*

Two gentlemen, Messrs T. H. Boothby and R. K. Lathrop, have each donated an acre of land at Leeds, Me., for a park. The area of land is small but the public spirit cannot be measured. The example should be catching.

\* \* \*

The town of Nantucket, Mass., has formally taken possession of that part of the island of Muskeget, not held by clear title, for the purposes of a public park. This amounts to some twenty one twenty eighths of the area of the island, and possession was taken under an act of legislature of this year.

\* \* \*

It is proposed to begin constructive work on a public park system for Indianapolis, Ind., early next spring. It is quite true that this in many respects fine city, considered with some earnestness, not only the desirability, but the necessity, of public parks for its people. It has already been delayed too long, but earnest and devoted work with help to redeem some of the lost opportunities.

\* \* \*

The Essex Co., N. J., Park Commissioners have secured the show place of the county, Eagle Rock, and land surrounding it, for a section of their park project. From this point the views are so diverse and enchanting that description would fail to reveal their characteristics. It is said that from this rock five per cent of the homes of the population of the United States can be observed. It is wise to devote to public recreation and pleasure such spots in any locality.

\* \* \*

The site of the Midwinter Fair in San Francisco, is now to be rapidly improved, the Park commissioners having decided to go ahead with the long contemplated work. An arena about the band stand is to be constructed capable of seating 15000 visitors. Drives and tracks will be made for both vehicles and bicycles, the various avenues being intersected by tunnels beneath them. A roadway will be built specially for the use of wheel riders direct from Strawberry Hill to the Ocean.

\* \* \*

Work has been commenced at last on the proposed Lake Front Park, Chicago. The magnitude of this project and its value to the city, can only be appreciated as year by year the work progresses, and the design develops on the ground. The park system has always been a pride to Chicago, and its extension the ambition of many progressive citizens. A project has been approved by the Park officials to construct an elevated boulevard or pleasure drive along Jackson street to meet Michigan boulevard; thus connecting the west side parks with the central part of the city.

\* \* \*

The city of Mexico, in old Mexico, is sadly deficient in public park areas. It is true it has a few lovely spots in its midst, but they are small, and compared with the parks of cities of the United States of equal size, amount to very little. The *Mexican Financier* has devoted much attention to this question and has suggested to the Mexican government to acquire a great and beautiful estate, lying to the southwest of the city and close to Chapultepec, known as the Hacienda de la Condesa, for the creation of a magnificent park, to which it readily lends itself. This seems to be a growing idea.

Owing to the construction of the Beaver River reservoir in the Adirondack region of New York state, some 80,000 acres of land belonging to Dr. W. Seward Webb, situated within the State Park boundaries in Hamilton and Herkimer counties, were damaged by an overflow, to the extent as claimed by Dr. Webb of \$300,000. An act was passed by the last legislature providing for the purchase of lands damaged by the construction of reservoirs for canal purposes by the state, which will probably lead to the purchase of the above property. In such a case Dr. Webb will drop all claims for damages. It is estimated that the expense to New York state of securing title to land damaged within the park will amount to about \$500,000.

\* \* \*

Preliminary work has begun on the New York Botanical Garden, Bronx Park. This was in the nursery for young trees and shrubs, in which considerable planting has already been done. The field work of the topographical survey, commenced September 1st, has been completed and the resulting map will be of the utmost importance in the making of the garden. Upon this map the working committee in conjunction with the park board, and in connection with the suggestions of the scientific directors, will lay out the general features concluded upon, fix sites for buildings, and complete the design, so that work may be proceeded with without delay in the creation of what is hoped to be the largest and most complete botanical gardens in the world. Great public interest has been manifested in the project which is exceedingly gratifying to the committees and an incentive to the best efforts.

\* \* \*

The design of G. Moretti, sculptor of New York, for the proposed gateway at Highland Park, Pittsburgh, is thus described in the Leader of that city: It shows two granite pedestals surmounted by graceful bronze groups of three figures of heroic size. The pedestals are set upon a base five feet high and each pedestal is made up of four round columns of polished granite, 38 feet high. Set in the niche between the columns and facing each other across the driveway are two beautiful female figures in bronze. Their feet rest on the base. Each figure has one arm extended aloft at full arm length holding a drinking cup, the bodies erect and gracefull, with just little enough drapery to display the beautifully molded outlines, bust and shoulders. From the base of the pedestals there extends to the right and left a granite railing five feet high. Each wing of the railing has a curve sweep of 30 feet. At the extreme ends there are small pedestals, each surmounted by a bronze eagle with wings outspread. A bronze fountain to correspond with the entrance is included in the design. It is to be placed some distance within the entrance and in such a position as to be seen directly in front of the gateway.

\* \* \*

The executors of the late Richard Smith of Philadelphia, Pa., who left \$500,000 for a memorial arch and \$50,000 for a children's play-house in Fairmount Park, have filed their account. The sites of the proposed improvements in the Park have not yet been selected.

\* \* \*

Baron Rothschild recently purchased a collection of antiquities found at Boscoreale on the slopes of Mount Vesuvius, and has presented them to the Louvre, Paris. The cost was \$100,000. It is believed that they were carried away in haste from Pompeii by some wealthy citizen to his country seat, but he was overtaken by the eruption. They consist of a number of beautifully chased silver vessels and gold jewelry. A number of handsome bronze objects found in the same place have been taken to Rome, among them two large baths, one of simple design without decorations or handles, the other with four handles, in the shape of movable rings, two at each side.



## CEMETERY NOTES.

The cemetery association of Nichols, Conn., is happy over the gift of Miss Fairchild of a new fence and one thousand dollars—a fund to keep the family graves in order and improve the grounds. Another practical benefaction.

\* \* \*

Hundreds of boxes of gold, silver, ivory, alabaster, onyx, marble, and other substances have been recovered from the Egyptian tombs. When the dead were buried these boxes were filled with perfumes and placed in the tombs. Many still retain the odor of the perfumes with which they were once filled.

\* \* \*

Mr. Levi Z. Leiter of Chicago, has purchased the old family burying ground in Washington county, Maryland, where his parents rest, and has ordered a brick wall erected around the Leiter family lot. The cemetery was part of a farm and it is said Mr. Leiter desired to protect the last resting place of his parents from desecration.

\* \* \*

The cemetery of the quiet little town of Bedford, N. H., has been greatly improved at the expense of Mrs. Charles H. Woodbury, of New York City, who has a strong attachment for the spot. A well and stone windmill tower with tank have been completed, and a general improvement of the grounds has been underway. Mrs. Woodbury could erect no better monument than this, its effects are far reaching.

\* \* \*

The suit of the city of Denver, Col., virtually against the authorities of the old Catholic cemetery on Capitol Hill, following an injunction, prohibiting further interments, was decided in favor of the city last month and a fine of \$25 and costs assessed. Exception was taken to the ruling and the case will probably be carried up. The cemetery had been removed and there is an ordinance prohibiting further burials at this old location.

\* \* \*

An unusual form of gift, nevertheless a good one, is that proposed by Mr. John G. Taylor, of West Chester, Pa. He has purchased a 100 acre farm at Forks of the Brandy-wine, which will become at his death the property of the Board of Managers of LaFayette Cemetery, at Old Birmingham Friends' Meeting House, the income for which will be used for the purpose of keeping the grounds and monuments there in good order. He has already done much in this direction.

\* \* \*

In reply to a contemporary which bemoans the slow progress of cremation *The Urn* says: "No cause for alarm. If there is any journalistic worrying to be done over cremation, *The Urn* will do it properly, but that occasion is not yet in sight as a matter of fact the number of cremations in the United States has doubled about every three and a half years. There is no sense at all worth logical deduction in the statement that from so many dead only so few were cremated. Put a crematory, as it will be in time, in every cemetery, for even choice, and the result will be surprising and distinctly in our favor."

\* \* \*

An interesting mound was recently opened just outside the city limits of Toledo, O., which contained twenty skeletons, all in a sitting posture and facing towards the east. At the side of each figure was a curious piece of pottery covered with pictorial figures. Most of the bones crumbled on exposure, but some were kept intact, and two skulls were almost perfect. The teeth are larger than those of the people of to-day, and the lower jaws are larger. Segments of flint were also taken out and a few small

crude implements. The pottery in this mound was different from that taken from Ohio or Michigan mounds opened previously.

\* \* \*

Contracts have been let for a new building and entrance arch-way for Erie Cemetery, Erie, Pa., to cost over \$20,000. This is to take the place of the structure now in use. It will be constructed of pressed brick and stone and have two stories. The first floor will contain superintendent's office, private office, large waiting room and storage vault. The superintendent's apartments will occupy second floor. A statement is published to correct an impression somewhat prevailing that this cemetery is a source of profit to incorporators. The land was originally purchased by an association of Erie citizens, and the money realized from the sale of lots is expended for improvements.

\* \* \*

While workmen were excavating for the foundations of a building in front of the old Presbyterian Church on Fourth Street, Cincinnati, O., they came across a tombstone and some skeletons. On the stone was an inscription, which showed its erection in 1793. Upon searching records the skeletons were identified as of well known pioneers. The site of this church is a landmark in Cincinnati's history, for the first church in this part of the country was built here, right among the Indians. This, with many other such facts, make quite a commentary on the "rush" with which the country has reached its present position, that burial spots of only a hundred years ago should be thus forgotten and themselves buried.

\* \* \*

A monument is now being designed, under the direction of William Tyson Gooch of Harding & Gooch, architects, New York City, for Mr. John W. Mackay, to be erected in Greenwood Cemetery, Brooklyn, a plot for which has been bought for \$38,000. It will be constructed probably of Westerly granite and in Doric design. It will rest upon a granite platform, and will be in effect a chapel with twenty chambers. The interior walls will be of brick and bluestone; those of the main corridor, white enameled brick. The ceilings will be arched and probably of granite. Each catacomb will be fitted with white marble doors, holding panels for inscriptions. The approximate cost of the structure is about \$250,000.

\* \* \*

The little republic of Switzerland offers many suggestive ideas in some of its laws in regard to burial, which other civilized countries may find it economic and advantageous to imitate at some time in the future. The U. S. consular reports contain much information on this and kindred subjects. In some of the Swiss cantons, the state provides for the burial of the dead. Coffins and all other necessary matters are furnished to certain appointed undertakers upon application, and everything connected with the interment is absolutely gratuitous, rich and poor both being entitled to the benefits of the laws, and all classes avail themselves of it freely. The whole subject as exemplified in Switzerland is very interesting, and would seem to be distinctly a mark of the civilization to which the Swiss republic has advanced in the general welfare of its citizens.

\* \* \*

The new entrance gates of Mt. Calvary Cemetery, Boston, Mass., costing \$20,000 has been dedicated. They are of quite rustic design, built of feldspar, taken from a neighboring ledge. The ledge from which the stone was taken is full of iron pyrites, which from oxydization has imparted to the stone beautiful shades. The bright colors—which run from vivid yellow into red, brown and green—is heightened in effect by the pointing of the joints in various colors of cement. A roof of green slate and



copper tile work tones down the whole structure. Surmounting the entrance arch is a massive gilded cross. The gates are of iron, painted green in semblance of ancient bronze. The buildings contains a spacious waiting room, with all conveniences, including toilet rooms and telephone, a large office with fire proof vault, the superintendent's office and a lodge for the gateman. The office and waiting room are finished in cypress and handsomely furnished.

There is a good story going the rounds of Bishop Wilmer, a well-known United States divine. One of his friends lost a dearly beloved wife, and, in his sorrow, caused these words to be inscribed on her tombstone: "The light of mine eyes has gone out." The bereaved married within a year. Shortly afterwards the Bishop was walking through the graveyard with another gentleman. When they arrived at the tomb, the latter asked the Bishop what he would say of the present state of affairs, in view of the words on the tombstone. "I think," said the Bishop, "the words 'But I have struck another match' should be added."

In Berlin there is a shorthand writer with a unique specialty. He attends all funerals of prominent persons, and takes down verbatim the addresses of the officiating clergymen. Then he prepares highly-ornamented copies of the addresses, and sells them to the friends of the eulogised dead. His business is so good that he has taken one assistant, and has advertised for another.

There has been discovered at Rome a monumental tomb representing a venator. It consists of a youth leaning on a lance, and holding in his right hand a looped string. He wears a broad belt, and gaiters reaching above the knee, and fastened with leathern straps. His shoes are laced, and he is accompanied by his dog, like a deerhound.—*Funeral Director's Journal.*

## Correspondence.

LYNN, Mass., Nov. 20, 1895.

*Editor Park and Cemetery.*

DEAR SIR: Our Ninth annual convention has come and gone, and we that were present felt that our time was well spent. Returning, some of us saying good-bye to Richmond, took the York River Railroad for the boat for Baltimore and had a delightful sail up the Chesapeake, arriving in Baltimore at 8 o'clock in the morning and spending the day in that city. We reached New York Sunday morning, and, passing the day there, left at eventide by the floating palace "Priscilla," of the Fall River Line, for Boston, and thence to our respective homes.

It always seems good to get home. We are now ready to start out for another year, hoping to have profitted by our journey to Richmond. Many words that were said and questions discussed will come back to us during the year, in connection with some work that we are doing and we will then find that we derived some knowledge from our convention.

Our membership should increase, and it would if cemetery

officials would give it more thought. If more of the superintendents would occasionally write something for your valuable paper it would do much to bring us nearer to each other and make the PARK AND CEMETERY still more valuable.

At our conventions the question is asked, Where is brother so and so, and we wonder why he is not present. Would it not be a good idea for every member that can not attend, to write a few lines and have them read at one of our meetings? It would be pleasant and it would let us know that absence was no indication of loss of interest.

There are many things that we can all do that will be of benefit. Let us try.

*William Stone,*

Pine Grove Cemetery.

### Our Deceased Members.

*Editor Park and Cemetery.*

DEAR SIR: The November issue of PARK AND CEMETERY informed its readers of the untimely decease of Brother George Renshaw. It came upon me very unexpectedly, as I had never learned of his being ill, and always looked upon him as a man that was in the possession of good health. In his departure our Association has met with a great loss. We deplore his loss, in that we were very intimate with each other, and at our conventions we were much of the time in close companionship, so that we feel as though we had lost a dear friend. It has never been our privilege to visit our late brother and view Elm Lawn Cemetery, where he has spent many years in beautifying the grounds. We sympathize with the managers of Elm Lawn Cemetery in the loss they have met in the death of their faithful and able superintendent.

The death of Brother James Hargraves of Wiltwyck Rural Cemetery, Kingston, N. Y., also gives an additional pang to our sadness. Thus one after another of our members are dropping out from our ranks, and as they depart it seems fitting that some one make a slight tribute to their memories.

*Chas. Nichols.*

Newark, N. J.

### Cemetery Reports.

Advance sheets of the annual report of "Oakland" Cemetery Association, St. Paul, Minn., for the year ending October 31, 1895, show the total receipts from all sources to have been \$19,482.95 and expenditures \$19,204.29. Of the latter the pay rolls consumed \$12,680.21, improvements of grounds \$1,619.95, three additional greenhouses \$1,173.62. The receipts included: Sales of lots and single graves \$7,233.00, interment fees \$1,913.00, tomb fees \$373.00, greenhouse sales \$3,710.40, interest from perpetual care fund \$3,620.00. The assets of the Associations are estimated to be \$218,700. The investments for the perpetual care fund amounts to \$86,200. As expected the report states that the cost of caring for the lots has been above the average the past year owing to the dry summer, and the depressed times must be given as the cause of the limited sales of lots.

\* \* \*

The annual report to the lot owners of Lakewood Cemetery Association, Minneapolis, Minn., shows the total profit of the year to have been \$9,244.90. The sale of lots were fewer and less frequent than in former years.

The trustees have decided not to allow any more cheap headstones or monuments in the cemetery, and limestone, sandstone or artificial material will be barred out. The height of all headstones in the cemetery will be limited to one foot. No person owning a lot in the cemetery will be permitted to make an interment in the same, if the deceased is other than a member of the family or a blood relative.



**Seasonable Hints for Cemetery Superintendents.**

Procure the best of lowering straps, which will save more or less trouble, of frequent occurrence, at the grave.

Have the graves protected with heavy plank for the carriers to pass over, and there will be no danger of a cave in of the grave.

Always have your tools in perfect order, sharp, and put away in a clean condition, to prevent rust. Give special care to the putting away of lawn mowers, clean them well and they will do better work in the spring and last longer. They will draw lighter and the parties using them will get over the ground with much greater ease.

The filling of the grave while the friends of the deceased are standing by should be avoided unless ordered otherwise. It causes unnecessary strain on the mourners.

In order to keep flowers on the grave in all kinds of windy weather, wire staples of all sizes should be made, and used freely to pin them to the ground.

Graves should not be mounded too high—just enough to allow for settling. The best of sods should be used and the graves well stamped to retain their proper shape.

This is a good time to finish up all the odds and ends of cemetery work, which may have got behind through the extra work upsetting the usual order of things. Cleaning up the grounds, burning rubbish, looking over the ground to be able to plan further improvements, and many other things that the practical eye will suggest.

*Items.*

**Publisher's Department.**

**NOTICE TO SUBSCRIBERS,** If this notice is marked with a blue pencil it indicates that your subscription to **PARK AND CEMETERY** has expired and a renewal of same is solicited.

Park Commissioners and Cemetery trustees are requested to send us copies of their reports.

Photographs and descriptive sketches of interesting features in parks and cemeteries are solicited from our readers.

**PARK AND CEMETERY** wants the names of every park and cemetery official or employee who would be likely to be interested in this paper. To the many subscribers who have sent in such lists of names, we return our thanks. There are many more that we should hear from.

Subscribers are again reminded that we want brief notes on any feature of park or cemetery work that will be of general interest. **PARK AND CEMETERY** is the only publication of its class and earnestly solicits the co-operation of subscribers in making it a help to all identified with such work.

Mr. Robert Waring, superintendent of the Tyrone cemetery, Tyrone, Pa., has issued a notice to the delinquents of his cemetery calling for the immediate payment of principal and interest on both burial lots and single graves, on penalty of forfeiture and they "will, as heretofore, be resold or used for single graves. Being in want of the cemetery's funds we cannot extend the time longer, and no lot is considered sold until full payment is made."

RECEIVED.

**PERILS OF PREMATURE BURIAL.** A public address delivered before the members of the legislature at the capitol, Albany, N. Y. Jan. 25, 1871, by Dr. Alexander Wilder, with an introduction by the author, Dr. William Tebb, of "The Recrudescence of Leprosy and Its Causation," and an Appendix. London: E. W. Allen, 4 Ave Maria Lane, 1895. The subject is being received with much force in

England, as well as in this country, and Dr. Tebb, to whom we are indebted for this pamphlet, is working to the end of radical reform in procedure of burial, etc.

**AMERICAN GARDENS AND GARDENING,** Newport Series, Newport, R. I., October, 1895: Lucius D. Davis. This is the first issue of a series of monthly numbers discussing the gardens of Newport, R. I., designed eventually to form a simple volume. Subscription price \$2 per year.

**Personal.**

Mr. Bellett Lawson, Chicago, is engaged in laying out a new cemetery in Des Moines, Iowa.

A. W. Hobert, superintendent of Lakewood cemetery, Minneapolis, Minn., has prepared plans for East Linwood cemetery, Boone, Iowa.

Mr. D. C. Johnson has been elected local superintendent of Clifton Park, Baltimore, Md. Mr. Johnson has been connected with the Clifton estate for many years.

Mr. Robert Scrivener, superintendent of Cedar Hill cemetery, Hartford, Conn., writes: "I was pleased to see the item in your valuable paper, 'Guild of Kew Gardeners.' I have my diploma for the two years of 1871-72. There were several I knew came to America, and I would be pleased to hear from or meet them."

**Testimonials.**

R. J. Haight:—Please find enclosure for subscription to **PARK AND CEMETERY**. I look for and welcome it, with its useful information, renewing us. All of the pleasant memories of the many we have met at the annual meetings, and the combining of parks with the modern cemetery, makes it worthy of a large circulation. Robert Scrivener, Sup't. Cedar Hill, cemetery, Hartford, Conn.

R. J. Haight:—My best proof as to how greatly I appreciate your paper will be my check herewith enclosed for another year. I think all persons interested in parks or cemeteries should have it.

E. Clarence Simon, Harrisburg, Pa.

**Interment Record and Lot Book.**

This system is thought to embrace the best features of the most popular forms of burial records now in use and may be adapted to large or small cemeteries. The Interment Record gives all of the necessary information in regard to the deceased, and the Lot Book locates every grave, so that it can be readily found at any time. The books are printed on heavy paper, substantially bound and furnished in different sizes, depending upon the requirements of the cemetery.

**R. J. HAIGHT, Pub.,** 334 Dearborn St., Chicago.



# PARK AND CEMETERY.

FORMERLY THE MODERN CEMETERY.

A Monthly Journal Devoted to Parks and Cemeteries.

R. J. HAIGHT, Publisher,  
334 Dearborn Street, CHICAGO.

Subscription \$1.00 a Year in Advance. Foreign Subscription \$1.52

VOL. V. CHICAGO, JANUARY, 1895. NO 11.

## CONTENTS.

EDITORIAL.....	181
*WASHINGTON PARK, ALBANY, N. Y.....	182
*GARDEN PLANTS—THEIR GEOGRAPHY, III.....	184
*WINDOW IN CHAPIN MEMORIAL CHAPEL, HOPE CEMETERY, SPRINGFIELD, MASS.....	186
*OAKWOOD CEMETERY, SYRACUSE, N. Y.....	188
*A COLUMBARIUM, CROWN HILL CEMETERY, INDIANAPOLIS, IND.....	190
FAIR MOUNT PARK ART ASSOCIATION.....	191
*GROUP OF WEEPING HEMLOCKS—VILLAGE PARKS.....	192
THE ARNOLD ARBORETUM, BOSTON, MASS.....	193
CEMETERY LAW.....	194
PARK NOTES.....	195
CEMETERY NOTES.....	196
CORRESPONDENCE.....	197
PUBLISHERS DEPARTMENT.....	198

\*Illustrated.

AN editorial in the December issue of *Stone* opens thus: "Some day 'a city of the dead' will be platted, in which private monuments will not be allowed to disfigure the landscape. It will not be a 'potter's field,' but the most beautiful construction which intelligence and skill can make. Individual graves will be designated by a mark that will neither obstruct the view nor mar the beauty of its charming stretches of sward and foliage, etc., etc." It then proceeds to ably discuss the question, prognosticating that in that day the monumental dealer's occupation will be gone, and that the cemeteries of to-day will bear witness against any excuse for continuing in the business, but suggests a broader field in architectural stone work. It is gratifying to note this expression of views from this journal identified with the stone industry. It is the logical outcome of our advancing civilization, which has for the past few years been finding expression in the modern cemetery.

THE National Sculpture Society, of New York, whose assistance has been invoked to decide upon the merits of proposed public monuments, and artistic questions connected therewith, on many occasions in recent times, has undoubtedly already been the means of much good in this direction. Some very important work is now about to be decided upon by the committee of the Society, notably the Sherman monument for Washington, and possibly the Lincoln monument for Chicago, for which \$100,000 was left by the will of the late

John Crerar. The eminent men, for the most part, composing the society warrant the assumption that the decisions of its committees will not only assure the erection of meritorious public statuary, but will raise the standard of such work generally. It is gratifying to note that the society desires to assist in the improvement of public statuary all over the country, to which end it offers its services to any parties having the work of providing or erecting public monuments. An opinion on the merits of such work from such a high source must be of benefit to a community and the National Sculpture Society deserves universal thanks for this advanced step.

VERY delicate question in park management is that of renting privileges, and it is one that requires most careful consideration in all its details. It has been quite frequently noted of late that efforts have been made by the proprietors or agents of popular amusements to gain the attention of park commissioners, and it has appeared possible that for the sake of the income to be derived, contracts might be made and the park be subjected to such inappropriate innovations. It is quite a question whether better satisfaction might not be obtained in the larger parks by the commissioners themselves, under proper subordinates, undertaking the provision of all necessary privileges, such as boating, refreshments, etc, instead of as in the majority of cases farming out such privileges on contract, although generally speaking this course has been fairly satisfactory. But the idea of admitting merry-go-rounds, wheels, toboggan slides, and many other kinds of popular diversion, into our parks is to be opposed on every score of park principle, and it does not matter of what high or advanced grade the amusement may be. The park must always rise to the ideal of recreative enjoyment to be gathered from beautiful landscape, enriched by the highest artistic efforts of well planned groupings of trees and shrubbery. The necessities of the community demand some space for more energetic exercise, which is supplied by well kept lawns which often improve the landscape design. But to consider for a moment the admission of amusement schemes, which in their nature as paying investments attract crowds of people, with the attendant frolicsome hubbub, should cause the relegation of their official supporters to private life, or lead to the establishment of public grounds especially arranged for such entertainments.



# PARK AND CEMETERY.



REFERENCES.

- |                            |                            |                          |
|----------------------------|----------------------------|--------------------------|
| 1. Children's Play Ground. | 8. Croquet Ground.         | 15. Bridge.              |
| 2. Rustic Shelter Outlook. | 9. Elm Grove Outlook.      | 16. Maple Outlook.       |
| 3. Refectory.              | 10. Lake View Outlook.     | 17. Lawn Tennis Grounds. |
| 4. Drinking Fountain.      | 11. Terraces.              | 18. Lake.                |
| 5. Croquet House.          | 12. Skating and Boathouse. | 19. Carriage Concourse.  |
| 6. Swings.                 | 13. King Fountain.         | 20. Tropical Garden.     |
| 7. Robert Burns' Monument. | 14. Flower Garden.         | 21. Aquatic Garden.      |

**Washington Park, Albany, N. Y.**

Our public parks are in a certain sense very diverse in their characteristic features, notwithstanding the fact that the chief efforts in their establishment is to impart to them those qualities which like unto nature herself shall give a sense of rest, refreshment and pleasure to such as may pass within their borders. Their diversity of course comes from the genius in their design, the ideal worked up to, and the quality of care and management bestowed upon them in their development. It is on these lines that such success in park building is secured as to result in certain parks attaining a reputation away beyond local recognition, and becoming objects of attraction to be enjoyed by all coming within their reach from every quarter.

This is in a large measure the case with Washington Park, Albany, N. Y., of which a map is given herewith. The history of the park dates back into the sixties, when the usual delays incident to such undertakings ran their course, until on May 8,

1869, the Board of Commissioners of Washington Park organized under "An Act in Relation to a Public Park in the City of Albany," and the following executive inaugurated active work; John H. VanAntwerp, President; Dudley Olcott, Treasurer; Wm. D. Morange, Secretary; Reuben H. Bingham, Chief Engineer; William S. Egerton, Engineer in Charge; Messrs. Bogart and Culyer, Landscape Architects.

In acquiring the property necessary to carry out the proposed plan, Albany experienced in a very full sense, the rise in real estate prices of the property contiguous to what had already been acquired by the commissioners. As each successive parcel was purchased it was realized only too late, how much said parcel had gained in value from the previous purchase of an adjoining piece for park purposes. Albany has also thoroughly realized the value to its property of its park system, and can point the finger of admonition to all sister cities to profit by her experience and attend to the park



question without delay and in a comprehensive spirit.

Washington Park comprises some ninety acres of land, very centrally located, and but for some private property breaking its outline at its north-west corner would be symmetrical. Of this ninety acres, sixty-five are in lawn and six in water. There are some six miles of walks and 3 miles of drive-ways.

An examination of the map in connection with the references, will display a unique arrangement. Points of peculiar interest are not confined to any particular section, but are distributed so that all parts of the park call for attention in their turn, affording a diversity of attraction, tending to distribute those enjoying its beauties, thus enhancing the refreshing ideas connected with beautiful natural surroundings and prospects, and stimulating the desire for exercise.

The active management of the Parks of Albany, is vested in standing committees, and the rules and regulations governing their use by the public while strict in the sense necessary to secure their best condition and maintenance are liberal in other respects.

Art other than landscape art has not been seriously considered in Washington Park. There is however a fine statue of Robert Burns, by Charles Calverly, which was completed by the addition of the four bronze panels in the pedestal, April 1, 1891. There is also a fountain, surmounted by a figure, "Moses Striking the Rock," by J. Massey Rhind. The references of the map give the location of these works of art, and it is needless to say that surroundings which they serve to adorn, emphasize their own merits.

The structures about the park have been designed to harmonize with the general ideas connected with park work, and while being graceful are substantial and are maintained with the utmost care.

The drinking fountain shelter is a structure of Moorish design; the superstructure is of wood erected upon a stone base. Its details are elaborately worked out, the dome and finial being gilded, and bright colors are used to carry out the effect. It is intended to form a cool restful seat about a fountain supplied with good cold water.

The Refectory is a building erected for the convenience of visitors and for the supply of light refreshment when required. In design it is of the Swiss Chalet style, constructed upon a substantial stone foundation with the roof of slate laid in parti-colors. The panelings of the sides and piazza ceilings are very elaborate. From the front piazza, looking east, a view of 1,400 feet opens up.

The Lake House is a wooden structure upon brick piers, of pleasing architecture, designed both for a summer and winter building. It is surmounted by a band stand, and the grounds around can accommodate a large number of vehicles and masses of people. In the winter the building is inclosed, heated and opened to the public as a skating house, and facilities afforded for that exercise.

There are also shelter houses in other parts of the grounds, an excellent provision for comfort, and heartily appreciated. The park authorities have also made it possible for a fuller enjoyment of outdoor games, such as croquet, tennis, etc., by furnishing the principal necessities, and one cannot help thinking that the facilities for recreation coupled with fine landscape effects, opportunities for social enjoyment of a becoming and elevating character, all combined in this comparatively small area, and that without one feature detracting from another, is perhaps the prime factor in the popularity of Washington Park.

After all the charm of Washington Park lies in its simplicity. There is nothing obtrusive anywhere, yet the most popular of park features have been introduced. The lawns are broad and excellently kept; the plantings of trees and shrubbery have been carried out to a certain extent in an ideal way. The aquatic garden is there, carefully improved. The tropical garden may be found as a special attraction. The flower bed portion is not intended to astound by its obtrusiveness, but is quietly gay in its exuberance of coloring, and to crown the efforts of the authorities, two flower shows are held annually, one of foliage and other plants in the summer and the crysanthemum show in the fall in the Lake House. These come in as popular park entertainment and are growing in importance.

In reference to these displays, Mr. Wm. S. Egerton, in his report just issued says: "The exhibition of border plants, supplemented by special exhibits of specimen palms of many varieties, agaves, and tender stove plants utilized in some localities especially adapted for their display, makes the exhibit in Washington Park somewhat exceptional in character, and particularly attractive to plant lovers.

"The midsummer exhibit of caladiums and other foliage plants was largely attended, at a season when many citizens are absent from the city. The exhibit gave striking proof of the fact that the love of color and form in foliage and plant life is as attractive to many as flowers."

The beauty and success of the Albany parks show care and study and the name of Mr. Wm. S. Egerton, Supt. of the Albany Parks, must be associated with them. He has been closely identified with their development from the earliest days.



## Garden Plants.—Their Geography.—III.

## II. PARIETALES.

## THE PAPAVER, BRASSICA, AND VIOLA ALLIANCE.

There are 28 tribes, 328 genera, and 2697 species in this alliance. Trees, shrubs, and herbaceous plants are included, but in the eastern United States they are limited to a herbaceous representation, unless indeed *Idesia polycarpa*, a Japanese tree, prove prosperous south. There is a much similarity between poppies and plants of the previous alliance, and even botanists rely a good deal on the milky juice of the poppies as a distinguishing character.

*Sarracenia*, "side saddles," as the English colonists called the flowers, are all North American bog plants. *Darlingtonia Californica* is very similar to *Sarracenia*.



DARLINGTONIA CALIFORNICA.

*Papaver*, the true poppies, have 26 species found over all the continents and in Australia—outside the Tropics. Their flowers are mostly brilliant in color often large in size and very showy. Their juices are narcotic, some are the basis of opium and its products. There are beautiful magenta scarlet varieties grown on the mountains of India which I have not yet seen in gardens. The oriental poppy is a brilliant garden ornament in North America; and sometimes on alluviums, the annuals do well, but on sands they are very fugitive, and short lived.

*Meconopsis* boasts 9 species principally in Eastern Europe, the Himalayas and Western North America. They are elegant plants with stalked, pinnate leaves, yellow juice, and yellow flowers in the European, and blue, lilac-purple, or rich yellow in the taller scarcer Himalayan ones. There are both perennial and annual species.

*Bocconia* has 3 species in China, Japan and Tropical America. *B. cordata* is seen in gardens where it is used for its foliage. It is hardy, large spreading, and rather coarse. It is best planted where it can be mowed around in American gardens, and so indeed are most plants of like character.

*Glaucium* "horned poppies" have 9 species in Europe, Eastern Asia, and North Africa. They are annuals or biennials with handsome yellow, orange, red, violet and tri-colored flowers. On the East coast of England some of these plants live on the sea shore quite within the influence of the spray. They flower for a long time, but like most of the poppy tribe the individual flowers soon lose their petals. The common yellow horned poppy



SANGUINARIA CANADENSIS.

lives several years near the coast, but inland must be treated as an annual or biennial. *G. violaceum* is one of the most fugitive of all, as the petals fall almost as soon as expanded. The scarlet horned poppy is an annual of great beauty, sometimes found in England.

*Ræmeria* has 2 or 3 species in Europe, West Asia and North Africa.

*Hunnemannia*, has 1 species in the United States and Mexico.

*Eschscholtzia* has 15 species all from Western North America. *E. Californica* and its various colored forms are best known, *E. tenuifolia* has however been cultivated. Both are useful showy annuals.

*Dicentra* has 13 species distributed over Central and Eastern Asia and North America. *D. spectabilis* is the most familiar and beautiful of herbaceous plants. There is a white variety, but not so good as the type. *D. eximea*, and *D. chrysantha* (the latter Californian) and some others are occasionally seen. *Adlumia* is a native climber.

*Corydalis* has 100 species distributed over the temperate portions of all the continents. They are very like *Dicentra* in structure. Some are fibrous



ESCHSCHOLTZIA CALIFORNICA.





PAPAVER NAUDICAULE.

some tuberous rooted, and many such as *C. nobilis* are handsome.

*Fumaria* has a great many described species, or reputed species, and perhaps 6 or 8 may be found with distinctive characters, from Europe, Central Asia and extra-tropical Africa. There are three species of these plants including a climbing one common in the British Islands. Their flowers are smaller than *Corydalis*, purplish red, pink, white tipped purple, etc. *F. officinalis* has become naturalized in several parts of this country. They affect dry situations, rubbish heaps and such places, and to clothe them with light feathery foliage may be useful. They are annuals.

*Mathiola*, "Stocks" have 36 species chiefly in the Mediterranean region and Eastern Asia. Two are found sparingly wild on the British coasts, the garden stock on the cliffs at Hastings, where it is distinctly shrubby, and the great "sea stock" which is biennial on the Welsh coasts. These two plants ought to be worth the attention of hybridists, seeing that there seems a possibility of their enduring our climate on the South Atlantic coast. *M. sinuata* is really quite attractive with its downy leaves and purple flowers. *M. annua* is the type of the annual vars. This genus may be regarded as a type of the four-petalled arrangement (crucifera) prevailing so largely in this alliance, and going far to distinguish it from the preceding one, but there are exceptions and anomalies among most plants.

*Cheiranthus*, "wall flower," has 12 species with a host of varieties in Europe, Asia, Africa and North America. It is represented by 3 species in our country. *C. asper*, *C. Menzeisii*, and *C. pygmæus*; *C. Cheiri*, common on old walls in England is a shrubby wiry plant with yellow very fragrant flowers, quite different in aspect and much hardier than the improved garden kinds.

"There may be gaudier on the bower, and stater on the tree.

But wall-flower, loved wall-flower, thou art the flower for me"

*Nasturtium* is a genus including the "Water cress" "yellow cress" etc., and not the *Tropæolum*, or "Indian cress."

*Arabis* is a genus of humble plants principally found in the temperate and Arctic regions of the Northern Hemisphere. They are mostly white flowered perennial or annual plants in 79 species, with a far greater number of names. *A. albida* and its variegated leaved variety are frequently seen. *A. "alpina"* is another form. *A. blepharophylla* is Californian, and has rose-purple flowers. *A. lucida variegata* is very extensively used for edging spring-flower beds in British gardens. *A. verna* is annual with blue flowers. *James Mac Pherson*.

(To be continued).

#### Swamp Plants on Dry Ground.—Beauty of the Oak.

It is remarkable that, with very few exceptions, plants which are found naturally in wet or swampy places do much better when transplanted in comparatively dry garden ground. What is known as the Swamp Magnolia is a good illustration of this. Nowhere in its native swamps can any one see as large or healthy plants as are to be seen everywhere in gardens. The explanation is that the plants are in obedience to the law of nature that everything should be made use of. The swamps have to be made use of by nature as well as dry land, and it has been so ordered that the seeds of certain plants shall only sprout in comparatively moist places. The trees have, of course to continue their existence where the seeds sprout. Nearly all the swamp plants that are found to grow so well in dry ground will not have their seed grow under such circumstances. The seeds themselves have to be planted in situations similar to that in which the plants grow naturally. Swamp maple, swamp magnolias, and the native holly are examples of plants found in swampy places, that flourish in dryer ground.

\* \* \*

Although the great beauty of the oak is in its foliage and habit of growth, a large number of them have additional charms in the fall of the year, by reason of the brilliant color of their foliage. It is remarkable that nearly every American oak will change to some peculiar shade of brilliancy, from lemon to yellow or deep crimson; while the species from Europe all die away of a green color. It is a characteristic difference between the trees of the two countries, in planting, therefore, for colored-leaved foliage in the fall, one may take almost any species of American oak, feeling sure that it will in some degree add an interest to the autumn coloring.—*Meehan's Monthly for January*.





WINDOW IN CHAPIN MEMORIAL CHAPEL, HOPE CEMETERY, SPRINGFIELD, MASS.

#### Stained Glass in Monumental Work.

Of recent years windows have been frequently placed in mausoleums and vaults, but owing to their more customary use in churches, this most important and beautiful form of memorial has scarcely been recognized as a feature of cemetery decoration. My attention was drawn to the fact on noticing in Woodlawn Cemetery a mausoleum entirely without ornament and beautiful simply from its proportions and the exquisite finish of the plain white stone. A great iron gate closed the entrance and through it one saw the warm bright sunshine, transmitted by a stained glass window, at the back, falling in mosaic on the floor. The window was neither a large nor an expensive one, but a conventional design in cathedral glass, and yet it filled the interior like a glorifying presence and as I went on to other monuments their gloom and vacancy impressed me as it had never done before. The trees were bare, and among their branches the points of numberless obelisks bristled, dwarfing one another and destroying the sentiment which before all others should pervade a cemetery—peace.

Why this pagan form has found such favor would be hard to tell. Perhaps some years ago when the Christian religions were not in such kindly fellowship as the teachings of Christ admit, a Protestant prejudice against anything which might seem to border on Romishness led to the adoption of Egyptian monuments and Grecian urns and many other things which, while excellent in themselves, are associated in other minds with customs far removed from those of the present day, and which might well give the coming centuries a curiously erroneous notion of our faiths and thoughts. And time will not lend to these more ambitious monuments the charm that we find in the old country churchyards where the breeze bends the tall silken

timothy and the crumbling headstones lean over the forgotten graves that somehow never seem as much forgotten as these neatly tended plots. Naturally enough an object belonging to a certain place or period never justified itself when disassociated from the conditions which created it, and I never see Cleopatra's needle rising battered and uncouth from its graded velvet sward in Central Park without wishing that America would send it back to its own Nile, its Egypt and its sandhills. And yet when we look at the greater part of the sculptured monuments erected thirty years ago, we cannot but feel grateful toward the inherent taste of those who avoided them by choosing the plain shaft. Now, however, we have sculptors whom other countries are delighted to honor, we have bronze foundries fitted to cast the finest work, artisans to follow out the most exquisite design in stone, and it remains only for our people to acquire a more trained appreciation of the difference between good and mediocre work,—for that which is very very bad usually announces itself. But it is generally conceded that perfect painting comes before perfect sculpture in the evolution of art, and it seems more than probable that it will be through the colorist that the general standard of memorial work will be improved until our burial grounds will contain much that is finest of our nation's art. No great buildings, no monuments in public parks gauge the development of a country as do its cemeteries. There alone is found record hopelessly true of the individual taste of all its people, and it is a fact full of promise that the newer parts of Greenwood and Woodlawn are so much finer than the old.

In Greenwood there are, beside the well known Whitney Chapel, a number of mausoleums, and of vaults whose catacombs alone run underground, in which stained glass windows have been placed, and



the foundation is at present being prepared for a memorial which will cost sixty-three thousand dollars. The time was not long ago when this price could not have guaranteed artistic work from American hands, just as the time may not be far distant when art will be the birthright of every individual, availed of or not availed of during life, but certain in great or humble form to mark his resting place, for in the words of a great French humorist, "the highest honor that can be paid a man in his lifetime is to erect a tribute to his memory when he is dead."

Stained glass is as varied as painting on canvas, and the difference between the "antique" or painted, and the opalescent glass might be compared to the difference between the old gothic painters whose sombre colorings had no aim as coloring but was merely a necessary medium for giving form to the figures they wished to represent, and the Venetian painters to whom color in itself was a delight and an expression of thought.

There are several distinct varieties of glass—English, German, Venetian, but the opal "which," as Mr. Will H. Low said not long ago in an address on the subject, "is so American an art that from patriotism we should know all about it," is being used almost to the exclusion of the painted glass in the finest windows.

The process of making the glass is a very interesting one, and some very beautiful effects are seen when what is to become "drapery glass" is poured out in smooth sheets and then deftly turned and waved in such a way as to make the substance into lines and exquisitely graceful folds. One of the most fascinating as well as the most difficult details of the work is the fitting together of the different pieces of glass which are to form the design, adding a thickness here to gain depth of coloring, changing a piece there, building and rebuilding in the frame until the glass reproduces the exact coloring of the cartoon beside it.

This glass is easily distinguishable from painted glass not only from the light and richness of the coloring, but from its seemingly warped surface and the milky patches that from the outside of an unlighted building seem unprepossessing enough unless they happen to give an effect of mosaic. Wire netting which is often used to protect expensive windows from stones or other accidents and the proverbial small boy, tends to dispel this unpleasant feature without dimming the translucence of the glass.

Curiously enough this American departure is rather more antique than "antique" glass. And again I cannot refrain from borrowing from Mr. Low, ("how much better had I stol'n the whole.")

"The art of making stained glass dates back to the tenth century and at first was however rudely the representation of objects, ornament or figures by transmitted light through pieces of various colored glass. As time went on an alleged improvement was made by painting certain portions of the glass to give more reality to the picture and rotundity to the modelling. This painting with vitrifiable colors has in other countries reached a degree where a stained glass window is almost a painted picture, but as a pigment on glass always tends to dull and darken its transparency, efforts were made about fifteen years ago to make windows of small pieces of glass so arranged that they would of themselves make all the differences necessary to the representation of figures and objects. This effort has been crowned with such success that to-day there is in our better windows no painting except such as serves to model the heads, arms and hands of our figures. Every fold of drapery, every leaf and branch of a tree, every flower or object represented is done by cunningly adjusted pieces of glass each receiving and transmitting the light undisturbed by the comparative opacity of paint. Where the colors of the glass are in themselves too strong or crude, or where it is desirable to modify one color by another, recourse is had to placing a second thickness of glass on the surface, or in extreme cases more, but when the sunshine falls through a window of this description you may know that no corrosive element of time can attack it and that barring fracture and destruction it will glow five hundred years hence as the windows which were put into the cathedral of Florence in 1434 gleam and glow in the sunshine of to-day."

The accompanying illustration is from a design made by Mr. Low and executed by the Tiffany Glass Company for the Chapin Memorial Chapel in Hope Cemetery at Springfield, Mass. The window is eight by fifteen feet, and even the black and white reproduction, which gives no sense of coloring nor the light that would be found in a photograph taken from the window itself cannot dispel the uplifting spirit of peace which the figures and the great over-arching wings impart.

*Marguerite Tracy.*

In the central park of Battle Creek, Mich., stands what was once a Quaker burial ground, but which has long ceased to be used, and from neglect and vandalism has become an eyesore. It comprises about two acres and would be a prize for building purposes. A real estate man conceiving the idea of a bonanza, proceeded to investigate with a view to scheming for a bargain, but while he could find the old trustees, the heirs to the lots had multiplied so much, and the prices asked for the various parcels so exceeded all present values that his prospects vanished. The property may have to be taken by the city in a few years and would form an excellent park site.



**Oakwood Cemetery, Syracuse,  
New York.**

Beautiful Oakwood is a term appropriately applied to this attractive resting place of the dead, which originally beautiful under nature's lavish hand, has retained this characteristic



OAKWOOD CHAPEL.

feature under the wise methods adopted and pursued in its transition. It comprises some 170 acres of land, situated not far from the center of Syracuse, N. Y., and includes hill and dale, of gentle declivity, no inclines impracticable, and half of its area natural woods, the white and black oak predominating. Its greatest elevation is 200 feet.

Oakwood cemetery was established in 1859, and now comprises some 170 acres, but has only one small lake used as a lily pond. It has eleven miles of gravel roads, and on the grades the

gutters are paved with cobble stones from three to seven feet wide. There are fifty seven sections laid out, of irregular size and shape, covering some eighty acres of its area; the largest lot contains 8050 feet, and there are several of 3000 to 6000 square feet of area, but probably the average may be set down at from 450 to 500 feet. No entire section is devoted to single graves; the system adopted is to locate a block of them not many in a place, in the interior of large sections. There is no "potters field," and this is a feature in accord with present ideas provided a true conception of "man's duty to man" stimulates the management.

No monuments or boundary posts are permitted on single graves and the markers are restricted to a height of 2 ft. 6 in. and a width of 2 ft. One body is only allowed in each grave and the price charged is ten dollars.

The lawn plan, as it is called, of cemetery design and maintenance, is adopted in the new portion of this cemetery, so that in the old grounds we still find the depressed paths between lots. About the newer sections grass paths are the rule and no gravel, cement or scrimshaw is used. Very liberal margins are left about the lots for ornamental planting, and all odd points and fractions are reserved for decorative effects about



VIEW IN NEIGHBORHOOD OF CHAPEL.



the grounds. No mounds on graves exceed five inches in height and few are above three or four inches.

No restrictions are as yet placed upon the design and form of monuments, except that they must be in every way proper, and only one is allowed on each family lot. All foundations are however built by the cemetery association, which at least prevents faulty construction in this most particular feature of cemetery work.

In regard to family vaults, the cemetery authorities exercise a

mentorship and all designs must be submitted for approval and accepted by the executive committee before any work is commenced upon them.

Hitherto the cemetery has not been provided with modern water facilities, but the coming summer will see a commencement of this important matter.

The Chapel and Receiving Vault combined, of which two views are given, is constructed of Onandaga gray limestone, and cost some \$20,000. The receiving tomb is arranged under ground and has a capacity of 200 bodies. The total number of interments is about 9000, and the average number per year at present is 375.

The management of this cemetery does not consider a greenhouse a necessary adjunct and in consequence Oakwood has none. Greenhouse plants can be bought so cheaply, and, moreover the planting of tender flowers is discouraged, so that greenhouse facilities have no attraction for the officials. Great care, however, is bestowed upon a small nursery, where a great variety of the best and choicest evergreens, deciduous trees, shrubs and hardy perennials are cultivated. This nursery furnishes ample stock in great variety for the ornamentation of the grounds as well as to accommodate lot owners. The plants are set out in the nursery very small and



DEDICATION VALLEY.

thus become acclimated and when required there is choice enough of good material for immediate effect which very rarely fails to grow right along. This is a policy which should be pursued more particularly than it is in all our cemeteries, and it would be well as a rule, if more attention were paid to the wild plants and shrubs indigenous to the locality. Many of our leading landscape men bestow much care in this direction and produce effects with familiar plants and bushes hard to be excelled in any other way.

The illustrations given speak well for the appearance of the cemetery. At the point illustrated by the view of "Dedication Valley" the services of dedication were held in November, 1859. Many fine monuments are scattered about the grounds.

The cemetery employs from twenty-five to thirty men, and in the spring augments the force by the addition of forty to fifty women, mostly German. The latter do the light work of raking up the leaves and cleaning up the grounds generally, and they appear to do the work satisfactorily. This is unique in cemetery work. The original surveyor of Oakwood was Howard Daniels. To the superintendent, Mr. Chaffee, is due the improvements now continually in progress, which are in line with progressive modern ideas.



**A Columbarium, Crown Hill Cemetery, Indianapolis, Ind.**

The accompanying illustration represents a small columbarium recently erected in Crown Hill Cemetery, Indianapolis, Ind., to receive the ashes of Mr. Gustav Bohn, a man of progressive ideas, whose body according to his will was taken to Cincinnati for cremation and the ashes returned to Indianapolis to be taken care of in the above cemetery by the wish of his widow.

As there is no provision in Indianapolis for the care of such remains other than burial, it was decided to build a columbarium on a small scale, and as will be observed by the dimensions this one is not larger than some cemetery monuments of ordinary size.

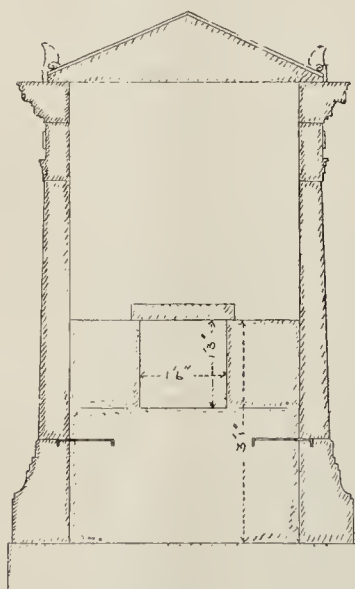
In this design the upper half forms a small chamber, while the ashes are deposited in a separate hollow space in the lower solid part and covered by a slab. The ashes are contained in a copper cylindrical box, five inches in diameter by six inches high, thoroughly sealed. This is amply large enough for the remains of an adult and is in the form in which they leave the crematory sealed by the officers of the society.

The monument is built of Indiana stone, in the classic renaissance style. The small iron door in front, of Grecian design, is gilded over with leaf gold, which gives refinement to the whole design. All the ornamental work was carved from plaster models. The door is large enough to admit a full grown

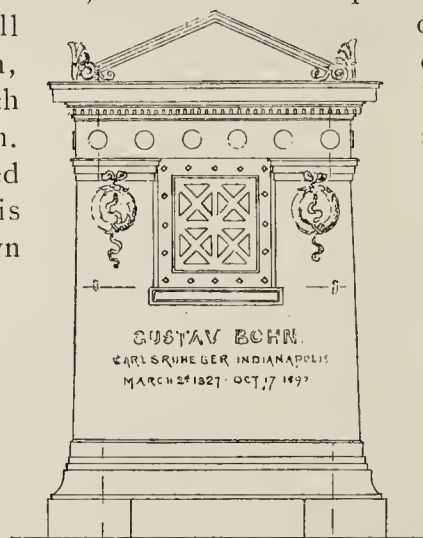


the same in the family lot, or where individual wishes are to be respected, offers an appropriate solution of the question. And more than this it presents opportunities by which the monotony of the cemetery monument may be relieved. The design here illustrated speaks for itself, and it carries with it the idea of an appropriate memorial besides a permanent receptacle for the ashes of the departed.

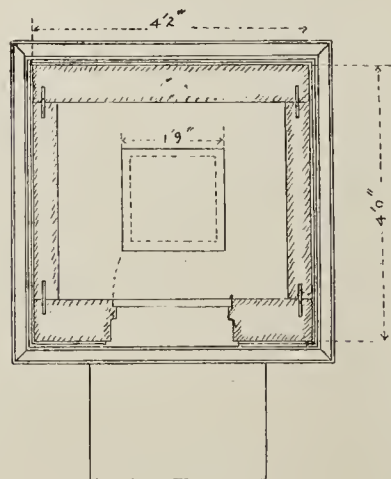
The architects were Messrs Vonnegut



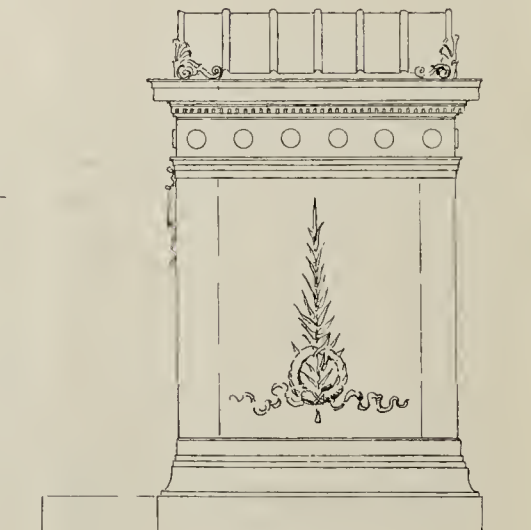
*Section*



*Front Elevation*



*Plan*



*Side Elevation*

person, and is kept locked; the monument could well hold the remains of an ordinary family. This method of caring for the ashes of the cremated, where it is desired for family reasons, or otherwise, to dispose of

& Bohn, Indianapolis, the monument being for the father of Mr. Bohn. It stands out well among other monuments on the top of a small hill in the cemetery mentioned in the opening paragraph.



**Fairmount Park Art Association.**

From advance copy of the report of Mr. Charles H. Howell, Secretary of the Fairmount Park Art Association, recently made to that body, the following extracts are given. Much interest attaches to this as it virtually presents historical facts relating to sculptural art in this country:

"This was the first organization in the country instituted for the following purposes: Of increasing the appreciation and love of sculpture; of adding to the number of its votaries; of encouraging sculptors in the practice of their profession; of cultivating public and private taste for good sculpture and promoting the refinements of life consequent thereon; of erecting statues, busts, fountains and other works of art, to the honor and memory of eminent persons and their deeds; of inducing other cities to form similar societies with like objects.

"Being pioneers we have not had the advantage of the experience of others, but have steadily advanced, year by year with increasing encouragement from our fellow citizens.

"In 1871, when your society was formed, there were few in this country who had adopted sculpture as a profession, and fewer encouraged the art either in connection with architecture, or in adorning gardens, parks or interiors. There was little taste and less demand for it. This is not surprising for the examples that were exposed were, with rare exceptions, weak in conception, and imperfect in execution, inviting ridicule rather than respect, and utterly incapable of arousing the admiration and enthusiasm produced by an exquisite conception, executed by a sculptor of great ability. We possessed a few reproductions from the antique, and some pieces from our students in Rome, Florence and Paris, who were compelled to live abroad, there being no demand here for their work.

"Those who were familiar with the Galleries and Gardens of the old world, were painfully aware of our poverty in the plastic art. They foresaw however, the great possibilities that could be developed by systematic, judicious, persevering efforts in the interest of better sculpture. Every well modelled creation will naturally awaken a new interest and a broader knowledge of the art, and a keener appreciation of the value of the profession.

"It may seem incredible that twenty-four years ago we had difficulty in finding works in sculpture worthy of purchase. There were no subjects offered by sculptors. For instance, the only group obtainable at that time, the model of the *Hudson Bay Wolves Quarrelling over the Carcass of a Deer*, was accidentally discovered in the basement of a plaster image-maker, where the sculptor had left it.

"At the Vienna Exposition of 1873, we secured

*The Dying Lioness* which won the Gold Medal for Wilhelm Wolff. Although our Centennial Exhibition of 1876 advanced the standard of taste to a marked degree in many directions, there were no notable examples of the plastic art that especially commended themselves for the purposes of this Society.

"In the past ten years, however, the Fairmount Park Art Association has given commissions involving an expenditure of over \$100,000, for original works, to Calder, Boyle, Cain, Fremiet, St. Gaudens, French and Potter, all complete in bronze except the last named which is at the foundry ready to be cast by Messrs. Bureau Brothers, Philadelphia.

"Years ago, as stated, it was difficult to find objects worthy of purchase, now your organization is known throughout the civilized world, and is constantly in receipt, directly and indirectly, of offers from sculptors who desire to be represented in the Fairmount Park collection of sculptors.

"Since the Columbian Exposition of 1893, there has been a marked increase in the number of those who appreciate the beauty of good sculpture, its value to a community, and who manifest an active interest in the progress of the art in this country. This awakening is especially gratifying to your society, which has been so deeply concerned in all that advances that noble calling. Another very important step was taken in the recent organization of the National Sculpture Society, wherein the sculptors themselves are associating for the advancement of the standard of their own creations.

"To the traveller impressed with a feeling for the historical, so closely intertwined with the annals of our city, Philadelphia must always be an object of attraction; and it seems quite within our province to add interest to the many localities, both in the city as well as in Fairmount Park, that are authentically entitled to receive such distinction. This action will tend to bring your association still more positively to the notice of the general public and will earn for it we feel certain, the commendation of all good citizens.

During the year 1896 we shall undertake to secure funds for the projected memorials of Dr. Benjamin Franklin and of Robert Morris, in which a great interest is manifested and a general desire evinced to participate in honoring the memory of those eminent citizens of Philadelphia."

The Fairmount Park Art Association has now over 1300 members. The report of the secretary can well be endorsed. The association has carried world wide respect, and its effects have resulted in great good to the cause of art, not alone in Philadelphia, but wherever its work has been studied and emulated.





WEeping HEMLOCKS, ETC., FAIRMOUNT PARK, PHILADELPHIA

#### Group of Weeping Hemlocks.

At the time of the Centennial at Philadelphia, in 1876, several Nurserymen made exhibits of hardy trees and shrubs. These collections were purchased afterwards by the Commissioners of Fairmount Park and added to the natural growths already existing there, so that many a rare tree and nice shrub were afterwards to be found in the Park. It is with pleasure that a representation is given here of a group of weeping hemlocks and pines, which were part of the collection spoken of. These hemlocks are a source of much interest to the numerous visitors to the Park. Having been growing for twenty years, they excell probably any other specimens in these parts. They are about six feet in height and eight feet in width. Weeping trees of this character are well suited for planting in positions such as these occupy. The portion of the grounds of the Park in which these are planted was set apart especially for evergreens, and many a nice specimen can be found here to-day.

The two deciduous trees back of the group of pines consist of the White Ash and the Black Oak. The right hand one is the ash. The large, dark looking evergreen on the right of the ash is Austrian pine, and one of the same kind is on the left of the oak. Facing the two deciduous trees and between the two weeping hemlocks on the right is a compact form of hemlock. This type is occasionally met with in beds of seedlings, some being more compact than others, and then they become the *nana* of catalogues. Well toward the left will be seen a tall, rather ragged looking hemlock of the ordinary type. In front of it to the right, are several nice pines, the White, Bhotan, Mandshurica and others being among them. Succeeding the last weeping hemlock on the left is a very rare pine, the

golden leaved Scotch. It stands ten feet high, and owing to its pretty golden foliage attracts a good deal of attention. In front of it is seen a dwarf white pine, *Pinus strobus nanus*, a pretty and useful sort. The deciduous tree, the furthest on the left, is a sugar maple.

The weeping hemlock is rather rare in nurseries, as, like all varieties, it has to be increased by grafting or some similar process. The usual way is to select some strong plants of the common hemlock, pot them a year in advance, bring them into a greenhouse and graft them in winter. If grafted in the open air, they are not so likely to succeed.

*Joseph Mechan.*

#### Village Parks.

The interest now everywhere manifested on the subject of parks as necessities to our urban civilization can be increased to advantage by the dissemination in our public print of appropriate and instructive matter on the important subject. In this relation we give some extracts from a communication by Mr. Frank H. Nutter, Landscape Architect, Minneapolis, Minn., to the *Northwest Weather and Crops* published in that city. He says:

"The park is no longer a luxury merely, but in the march of civilization has, like modern systems of water supply and sewerage, been found a necessity in meeting modern standards of living. Again in the daily life of many of the small towns, which are equally removed from the constant occupation of the farm, and the opportunities afforded by the larger cities for any desired amusements, there is a certain monotony of life to which the public park, if properly established and maintained, may come as an antidote; and in the communion with nature, which may be enjoyed in its quiet shades will be



found a relief to the mind chafing against the quiet of its environments, as surely as to the one excited and strained by constant contact with the bustle and worry of city life and business.

As a matter of economy the establishment of a park may sometimes be urged. Many a village whose plat was originally laid out without any particular regard to the natural features of its site finds on its hands problems of grading and drainage, involving many difficulties; with blocks that will require much expense to make them available for business or residence purposes, and which unless so utilized will speedily become common dumping grounds and breeding places for disease, and with streets to be graded along these blocks at considerable expense. Let the matter be carefully studied, and if the remedy be not perfectly clear at first it may be easy for one accustomed to the treatment of such cases to point out a way in which some of the adjacent streets may be rearranged or vacated and the objectionable blocks be united in a park, in which the features of the ground which before made it unavailable for ordinary uses shall render it still more beautiful and picturesque as a park, and thus become the center of the out door life of the town. It is easy to name villages in this state where action of this kind at the proper time would have been and even now may be of great financial advantage to the municipality.

Too often it happens that a community has close at hand advantages for establishing a park, by utilizing the lands bordering some stream or lake, which from very familiarity they are overlooking in their search for the proper location of a pleasure ground.

Many a prairie village has, however, no special material feature which may be seized upon to beautify as a park; but if it has an area of level ground for the purpose, a thoughtful arrangement of trees and shrubberies, with paths and seats, and perhaps a fountain, or monument of local interest, will furnish a resort that it may well be proud of.

A village or city play ground is something rarely considered but which would "fill a long felt want" in the life of many communities and doubtless be a boon to many of the young people, who, with nothing better to occupy their time, spend it in the street, in the store or in the saloon; if properly arranged it could offer healthy recreation to the young of both sexes by screening portions of it with trees and shrubs, while seats beneath trees around the border would allow those of more mature years to enjoy the sports in which they no longer join. In all this it should, however, be borne in mind that the purpose of the park for rest and refreshments, and of the playground, for recreation, are to a cer-

tain degree incompatible, and it will be difficult to unite the two on one tract of ground, unless the area is considerable.

#### **The Arnold Arboretum, Boston, Mass.**

The Arnold Arboretum is a unique feature in the Boston Park system. It combines scientific with recreative functions to a remarkable degree. It is a department of Harvard University and was established from the bequest of the late James Arnold of New Bedford, who left \$100,000 for the purpose. It is the foremost "tree museum" and the largest scientific garden in the world close to the heart of a great city. In fact it is the only genuine arboretum existing, all other collections of trees being merely adjuncts to botanical institutions. Including a large addition just made on the south side the arboretum has an area of 222 acres of remarkably diversified and beautiful hill and valley country. The greater portion of the arboretum occupies land that belonged to Harvard University as a portion of the Bussey estate.

The Arnold Arboretum was established in its present shape by the co-operation of the city of Boston with the University. In consideration of its value as a feature of the park system and of the consequent enhancement of its educational importance, an agreement was made whereby the city constructed the roads and footways through the place, and bounds itself to maintain them and police the grounds, while the university assumes the care and maintenance of the remaining portion. This was accomplished through the taking of the entire area by the city by right of eminent domain and then leasing all but the space occupied by the roads and walks back to the university for a term of 999 years, for a merely nominal consideration. In this way about two and a half miles of first-class park roads have been constructed through the arboretum, and under an agreement made this year, about a mile of additional roads will be built in the same way through the enlargement on the southward.

The successful establishment of the arboretum is chiefly due to its director, Prof. Charles Sprague Sargent, of the chair of arboriculture at Harvard University, and author of two monumental botanical works—his report as chief of the Forestry Division of the Tenth Census, and "The Sylva of North America.—*Municipal Engineering*.

A fact not realized as it deserves is that to beautify small parks or odd pieces of ground, the wild plants and bushes of the locality can be utilized. It is because they are common that they are slighted as a rule, but it would surprise many what a little cultivation and care will do for these wild things.



**Cemetery Law.**

## TAXATION FROM WHICH GRAVEYARDS ARE NOT EXEMPT.

The exemption from taxation authorized by article 9, section 1, of the Pennsylvania constitution of 1874, it has been held relates to taxes proper, or general public contributions levied and collected by the state, or by its authorized municipal agencies, for general government purposes, as distinguished from peculiar forms of taxation, or special assessments imposed upon property, within limited areas, for the payment of local improvements therein, by which the property assessed is specially benefited and enhanced in value to an amount at least equal to the assessment. As graveyards are in the same category with churches, in the exempting clause of the constitution, the supreme court of Pennsylvania now holds the above conclusion which was reached in a church case applies to graveyards and they are not exempt from assessments for paving streets in front of them.

## BOARDS OF HEALTH TO CONTROL BURIALS.

A law has been passed in New Hampshire which provides that boards of health in cities shall have charge of the granting of permits for the burial of the dead; and no interment, disinterment, or removal from the city of any dead body of any human being, nor deposition thereof in any tomb or vault, shall be made without a permit from said board or their duly appointed agent, nor otherwise than in accordance with said permit. No such permit shall be issued until there has been delivered to the board a satisfactory written statement containing the facts required by section 1 of chapter 173 of the Public Statutes, together with the certificate of the attending physician as required by said chapter, or in absence thereof such other evidence as may be required by law. Upon the receipt of such statement and certificate the board shall forthwith countersign the same and transmit it to the city clerk for registration.

## MINNESOTA CEMETERY LEGISLATION.

Considerable legislation was enacted at the last meeting of the legislature of Minnesota, looking to the improvement of the Cemetery laws of that state.

Chief interest centers in No 142, which disposes of a cemetery lot in such cases as sometimes occur where a testator fails to mention his cemetery lot in his will and makes some charitable institution or outside party residuary legatee. It also saves trouble among the heirs. The following is an extract from the law:

"Upon the death of any such proprietor" said lot, unless otherwise disposed of by will, as hereinafter prescribed, shall descend as follows: 1. To the surviving wife or husband of such decedent. 2. If there be no wife or husband surviving, then to the eldest son of such decedent then living. 3. If there be no

living son, then to the eldest daughter of said decedent. 4. If there be no living daughter, then to the youngest brother of the decedent. 5. If there be no living brother, then to the youngest sister of the decedent. 6. If there be no surviving wife, husband, son, daughter, brother nor sister of the decedent, then such lot shall descend to the association maintaining such cemetery, in trust, for the uses of a burial lot for the decedent and such of his relatives as the trustees of said cemetery may deem proper. But said association, or, with its consent, any person to whom such lot shall descend, under the provisions hereof, may grant and convey the same to any one of decedents' sons, daughters, brothers, sisters or grand-children, and such grantee shall there after be deemed the proprietor thereof. Any proprietor of a lot may dispose of the same by will to any one of his relatives who may survive him, or to such cemetery association, in trust, as aforesaid, but no such lot shall be effected by any testamentary device unless the same be specifically mentioned in the will. No interment shall be made in any such lot, except by written consent of the association, of the body of any person who was not, at the time of death, the proprietor thereof or a relative of such proprietor, either by blood or marriage."

Should it occur perhaps that a cemetery was being conducted in such a manner as to create a nuisance, No. 372, of which the following is an extract, provides that the city or village could exercise its police power to abate. Cemeteries are not taxable or assessable in Minnesota:

"That all lands adjoining any incorporated village in this state used as a cemetery, or for burial purposes, or that shall hereafter be used for such purpose, shall be and are hereby made a part of and included in such incorporation."

No. 400 clears up some uncertainties in the old law on which it was doubtful whether the trustees would be authorized to use any of their funds to purchase additional ground under any circumstances.

Any cemetery association heretofore or hereafter organized under the provisions of the General Statutes of 1878 and any amendments thereof, which is or may be conducting a cemetery within the limits of any city in this state having a population of more than twenty-five thousand (25,000), may by a two thirds vote of its board of trustees use any portion of the general fund of such association for the purpose of purchasing or acquiring additional lands, not exceeding four hundred acres, for cemetery purposes or to establish a new cemetery outside and adjacent to or lying near the city in which such cemetery is located.

After such new cemetery shall have been established not less than fifty per centum of the proceeds of the sale of the lands or lots therein shall be annually paid into the funds from which such purchase money was taken, until the full amount so taken therefrom shall be paid with interest thereon.

The question of statuary in the parks of Chicago appears to be about to be solved if promises and prospects are realized; but like other of our large cities, it is highly important that competent authority should be called in to decide upon the merits of any particular work as well as the site most appropriate for it. Several important works of sculptural art should soon be ready for such official approbation, and it is to be expected that satisfactory results will obtain.



PARK NOTES.

The Wilmington, Del., Park Commission has decided to print a report of its work for the past twelve years in the hopes of interesting the people in park work.

\* \* \*

A scheme in connection with the boulevard and park system of Detroit, Mich., is to construct bridle paths for equestrian pleasures. An effort is being made by which it is hoped eventually a bridle path will extend all around the city.

\* \* \*

Park Commissioner Squier, of Brooklyn, N. Y., on the question of accepting the much talked of Heine Monument for Prospect Park, is cited as saying, that there is no place for it in Prospect Park and that the best landscape engineers have given their opinion that no more statuary ought to be allowed in that park.

\* \* \*

In connection with the project for a National Military Park at Vicksburg, Mass., the Jewish Cemetery Association, at a meeting, unanimously resolved to give to the government for incorporation in the park, a portion of the cemetery property whercon some of the severest fighting during the siege took place. This action has met with the warmest commendation and should serve as an incentive to others.

\* \* \*

The Fine Arts League of Philadelphia has officially notified the Fairmount Park Art Association of its cordial approval of its aims and purposes, and in connection with the intention of the association to provide the city of Philadelphia with memorial statues of distinguished citizens has offered its services to aid in carrying out the project. The Fine Arts League is composed of delegates from The Philadelphia Sketch Club, The Philadelphia Society of Etchers, The Philadelphia Society of Artists, The Art Club, The Artists Fund Society, The Philadelphia Chapter of the American Institute of Architects and the T-Square Club.

\* \* \*

At the last session of the Nebraska legislature a law was enacted providing for the appointment of three park commissioners in cities of over 5,000 and less than 25,000 inhabitants, possessing one or more public parks. These appointments are to be made on the second Monday in January, by the district judge. These commissioners may order improvements made on the parks within a limit of \$15,000, and the mayor and city council are authorized to make a levy of not less than one half mill and not exceeding two mills on each dollar of real estate or personal property within the corporate limits of the city for park purposes. The law is looked upon as a good one.

\* \* \*

A bill was introduced in Washington last month to provide for a national military park on the Palisades of the Hudson and the preservation of the Palisades mountain from destruction by blasting and other agencies, prepared by the commissioners appointed last winter by the Legislatures of New York and New Jersey. The joint commission argues that over four million people would have access to the park, and that as the tract overlooks New York, Jersey City, Hoboken, Yonkers, Newark, Dobb's Ferry, Hastings and the surrounding country, its eminences would furnish a field of action for American troops that would rival the rock fortifications of Gibraltar or Quebec.

\* \* \*

A movement is on foot to promote and secure the passage of a bill through congress to provide for the conversion of the

famous Pipestone Indian Reservation, Minnesota, which includes the Pipestone quarry, all owned by the U. S. government, into a Pipestone Indian National Park, and its improvement and perpetual maintenance by the government. "Subject to the existing treaty rights of Indians, to dig their sacred pipestone for the purpose of carving the Calumet pipes of peace, etc." The consummation of this project would emphasize the poetic charm attaching to the spot where:

"On the Mountains of the Prairie,  
On the great Red Pipestone Quarry,  
Gitche Manito, the mighty,"

made the Peace pipe "as a signal to the nations."

\* \* \*

The Yellowstone National Park comprises a tract of land near the headwaters of the Yellowstone River in Montana and Wyoming. It is 62 miles long, north to south, 52 wide, east to west, and contains about 3,348 square miles. It has an average altitude of 8,000 feet. From the annual report of the Secretary of the Interior it appears that all the game continues to increase and prosper except the buffalo, which is continually hunted, and owing to its predatory habits carrying it into Idaho, where the game laws are very deficient, it will, unless more decided efforts are undertaken to preserve it, become extinct. The Smithsonian Institution has been supplying funds for the construction of a corral, which is intended for the retention of such bison, elks and other game as may be gathered into it, with a view to keeping them during the winter. The fish planted in the streams have succeeded wonderfully with one exception, and it is remarkable what quantities are caught each season without detriment to the supply. The greatest need of the park at present, according to the acting superintendent, is a thorough definition of the boundary lines, so that recognition anywhere should be positive at once. The system of patrol has been very successful in the prevention of fires.

\* \* \*

In a preliminary report to the Park Commissioners of Indianapolis, in which the suggestion is offered that it is high time that city should secure desirable lands for park purposes, Messrs Olmsted and Elliott make the following general statement on the subject of parks: Theoretically, a complete and satisfactory system of parks for a large city should include (1) a central public ground, upon or about which may be grouped the principal public and semi-public buildings; (2) a series of squares or small public grounds so distributed that they may be used freely at all hours and be within a short walk of everyone's home, (3) a series of local parks or city parks of greater extent, and having more varied and interesting topographical features, which may be developed into pleasing, but rather restricted, passages of scenery, combined with various artificially decorated features and means for amusement; (4) one, or possibly more, large rural parks, situated on the outskirts of the city, and comprising broad stretches of pastoral or woodland scenery, extending over hundreds of acres of land, where one may walk for an afternoon or drive for an hour or two, at least, without having to go twice over the same ground; (5) one, or possibly more, great public reservations, situated at some distance from the city, thousands of acres in extent, where most of the ground is left wild or encouraged to become so, where the sense of relief from urban conditions will be complete, and where all may roam at will over the meadows and through the woods without the restrictions necessary in city and even most rural parks; (6) parkways connecting two or more of the public pleasure grounds or forming agreeable approaches to them, and which may be either formal or informal, and combined with irregular (though restricted) stretches of more or less natural scenery, such as sloping banks, groves of trees, patches of shrubbery or the banks of rivers.



## CEMETERY NOTES.

The Crematory at Forest Home Cemetery, Milwaukee, Wis., will be completed by the first of March.

\* \* \*

In St Agnes cemetery, Albany, N. Y., up to January 1, 1896, there have been 11,534 interments, of which 780 were made last year.

\* \* \*

An annual tax of fifty cents per lot is levied by the Mapletown, N. J., Cemetery Association to provide for the expenses of caring for the grounds.

\* \* \*

It is expected that the new mortuary chapel in the Fair Haven, Conn., cemetery will be completed and dedicated next memorial day. This chapel is intended as a memorial to the soldiers and sailors buried in the cemetery.

\* \* \*

In the annual meeting of the Mount Royal Cemetery Company, of Montreal, Canada, the report showed receipts for the year ending Nov. 30, 1895, of \$26,020.71 and expenditures, \$24,573.09. The subject of cremation was brought up and the building of a crematory strongly advocated, but the matter was postponed for a year.

\* \* \*

The report of the Riverside Cemetery Association, Appleton, Wis., showed total receipts for year \$4,834.57, which added to cash on hand Jan. 1, 1895, equals \$6,525.26. Total disbursements amounted to \$6,420.43, of which \$1,981.38 was for new greenhouses. The greenhouse receipts for past year were \$1,342.57.

\* \* \*

Beautiful as Arlington Cemetery, Washington, is with so much historical sentiment clustering about it, and containing so many names of military renown, its law forbidding the burial of the wives of its sleeping tenants deprives it of many more honors. It is quite debatable whether the patriotic idea of surrendering to such law is of more value than the respect due to the closest of family ties.

\* \* \*

Some recent flagrant cases of grave-robbing for dissecting purposes in Topeka, Kans., has aroused intense indignation on all sides. An exchange says that there is no specific law in Kansas against the crime, and that although the legislature has been called upon many times, nothing has been done towards enacting this very necessary legislation. In the present case public indignation nearly caused the destruction of property and this should lead to legislative action.

\* \* \*

At the annual meeting of the Riverside Cemetery Association, Cleveland, O., the president reported the association free from debt and with an available surplus of \$15,000 over all obligations. The most important improvement begun last year was a steel bridge, 305 feet long, spanning the ravine between the old and new parts of the cemetery. This involves an outlay of \$14,000. Many other important improvements were carried out. The report also presented a brief review of the Indian history connected with the cemetery and urged that all such data be carefully deposited in the archives of the association. The matter of constructing a new stone office building was referred to the executive committee with power to act.

\* \* \*

It has often been observed in these columns that the Wom-

an's Associations of our towns and villages, could with honor to themselves, appropriately undertake the care and beautifying of the Cemetery, and it is gratifying to note that this idea is gaining ground to the practical benefit of the places affected. In Massillon, O., the Massillon Woman's Cemetery Association has just held its annual meeting and in order to raise funds it was suggested that each member should endeavor to earn by her own efforts by April 1st, as much money as convenient and possible, to put in a general fund for work in the cemetery, which work was expected to open about that date. This kind of practical enthusiasm will work wonders in Massillon and elsewhere when tried.

\* \* \*

An important case in its results in relation to lot owners rights in cemeteries may be that of O'Connell and the Catholic cemetery officials at Cedar Rapids, Ia. The late Henry M. O'Connell was buried in the family lot and in due course his wife was also laid there. The body of the wife by direction of certain parties in control of the cemetery was removed from the lot and buried outside the enclosure without due permission, consequent it is said upon her not having paid proper attention for some years to her church. The sexton was indicted by the grand jury. Another point in this remarkable case is, that the administrator of the estate allowed some \$425 to the church for masses, and the judge of the district court has decided that there is no provision of law for the taking of money belonging to minor children for spending in such a manner. The outcome of this litigation will be of general interest, in that it may decide what part denominational prejudices play in public cemeteries.

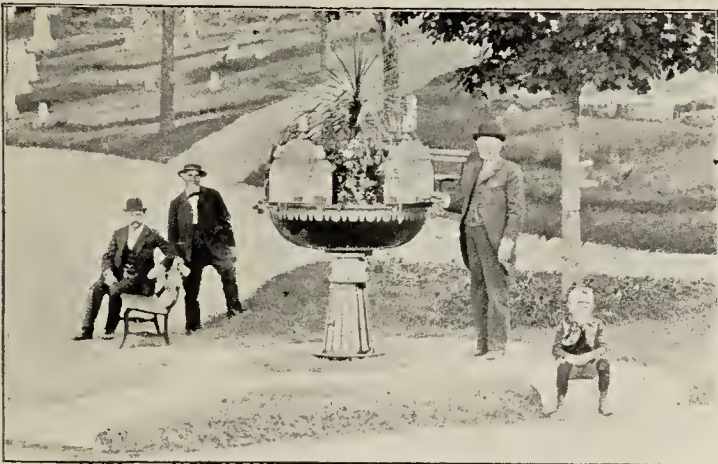
\* \* \*

The Onondaga County Cemetery Association, organized last August as recorded in PARK & CEMETERY, for the purpose of preserving existing memorials of the dead and of beautifying the various burial plots about the county, met in annual session Jan. 8, in Syracuse, N. Y., and received reports from its officers. The election of officers resulted in the re-election of the entire list as previously published, with one exception. In the course of his report, President George H. Wicks said that something should be done to improve the county cemeteries, many of which had been sadly neglected. He suggested a commission who should investigate and direct such work as should be deemed necessary, and that it would be a good idea to have a bill introduced in the legislature giving the association authority to demand of cemeteries the uniform care of lots. During the meeting Prof. L. H. Bailey of the horticultural department of Cornell University delivered an address on "Suggestions for Cemetery Gardening."

\* \* \*

The Mexican Cemetery at Guanajuato is thus described by a correspondent of the *Boston Traveler*: There is hardly room in Guanajuato for the living, so it behooves her people to exercise rigid economy in the disposition of the dead. The burial place is on the top of a steep hill, which overlooks the city, and consists of an area enclosed by what appears from the outside to be a high wall, but which discovers itself from within to be a receptacle for bodies, which are placed in tiers, much as the confines of their native valleys compel them to live. Each apartment in the wall is large enough to admit one coffin, and is rented for \$1 per month. The poor people are buried in the ground without the formality of a coffin, though one is usually rented in which the body is conveyed to the grave. As there are not graves enough to go round, whenever a new one is needed a previous tenant must be disturbed, and this likewise happens when a tenant's rent is not promptly paid in advance. The body is then removed from its place in the mausoleum, or exhumed, as the case may be, and the bones are thrown into the basement below.





DRINKING FOUNTAIN, BLOSSOM HILL CEMETERY,  
CONCORD, N. H.

The above illustration represents a drinking fountain presented to the Blossom Hill Cemetery, Concord, N. H., by ex-Mayor H. W. Clapp, the patentee. Mr. E. A. Moulton, the superintendent says it is very ornamental after the plants have made a good growth and exceedingly useful as giving four faucets from which to draw water. The large bowl is four feet across which gives room for quite a number of plants. The cost of the fountain was about one hundred and fifty dollars.

#### Rules and Regulations.

The following alterations in the rules of the Lakewood Cemetery Association, Minneapolis, Minn., were passed at the recent annual meeting:

"No monument or headstone nor portion thereof, and no portion of any vault or tomb above ground shall be constructed of lime or sandstone or any artificial material."

"Headstones for graves will not be allowed over one foot in height from the surface of the ground, nor less than six inches in thickness, except where they are made to correspond with other stones already in the lot, and must be placed on foundations. No footstones will be allowed."

"No proprietor of any lot, or part of a lot, shall allow any interment to be made therein, of the body of any person who was not at the time of death, a relative of such proprietor, either by blood or marriage, without having first procured the written consent of the trustees thereto, signed by the president and secretary, and no such consent will be given by said trustees in any case, except upon written application therefor, signed by the proprietor, stating the reason for such request and distinctly declaring that no remuneration whatever has been received, paid or promised for the privilege of such burial, and the trustees reserve the right to withhold such consent whenever they shall deem it proper so to do."

In the future no mounds will be allowed over new graves, and as far as practicable, it is desired to get rid of those already existing.

## Correspondence.

GREENLAWN CEMETERY, Columbus, O., Dec. 11, 1895.

*Editor Park and Cemetery.*

DEAR SIR: We had an innovation in our cemetery on Dec. 10th, 1895. It was the burial of the remains of a Mrs. Kumpf, or rather her ashes, the first we have received here of a body

cremated in a crematorium. It was by her request that her body should be taken to Cincinnati, Ohio, for cremation. The ashes were then shipped to Columbus, and buried in the family lot by the side of her husband. The ashes were contained in a small tin box six by eight inches.

*John F. Stephens.*

DEC. 16, 1895.

*Editor Park and Cemetery*

DEAR SIR: I find many articles in the PARK AND CEMETERY that interest me very much. For instance, about one year ago I noticed an item telling how to cut frost with salt which I tried and I can say that it works like a charm. This winter I have cut frost 18 inches deep and find it a nice help.

Now as this paper is instructive in many things, I would like to enquire, perhaps with many others, concerning digging up the remains of persons who have died of contagious diseases. I have disinterred remains of some who have died of diphtheria, etc., without fear, and have never met with any bad results. Now I have a case on hand upon which I would like information from any of your readers having experience. It is:

Is there any danger in digging up remains of a person buried for 25 years that had died of small pox?

It just occurred to me to write to you in hopes of getting some information in this direction, which I believe would be interesting to many superintendents.

*W. R. C.*

It seems incredible that any danger could possibly attach to the removal of remains buried for twenty-five years; yet science has revealed to us wonderful things concerning disease germs and their vitality, that without records of experience at hand it is hard to make positive statements. Some of our cemetery officials may give our correspondent light on the subject, and we invite their experience.—[EDS.]

CAMDEN, N. J., Dec. 18, 1895.

*Editor Park and Cemetery:*

DEAR SIR:—Being absent from home the day my paper was sent for the Richmond meeting of the Association of American Cemetery Superintendents, is the cause of two errors in same which kindly correct. The scoop carries 3 cubic yards instead of 8, and the ten foot border should be one foot.

GEO. E. RHEDEMEYER.

\* \* \*

Mr. D. R. Martin, who has been for 35 years sexton of the Oddfellows Cemetery, at Rochester, Ind., give us the following as the method he adopts to secure a neat and tidy appearance at burials: I use a white curtain 7 yards long by 44 in. wide with a  $\frac{3}{4}$  in. hem on each side. Every 5 inches I sew in a  $\frac{3}{4}$  in. brass ring on both edges, through which I pass  $\frac{1}{4}$  in. iron rods and support them on hooks on the frame around grave. I use a heavier rod at bottom which holds the curtain firmly down. The rods can be taken out and the curtain folded up in five minutes. In filling I never allow but one man to fill while one tamps with a heavy tamper, and this well done, prevents water from running into the grave.

### Association of American Cemetery Superintendents.

O. C. SIMONDS, "GraceLand," Chicago, President.

G. W. CREESEY, "Harmony Grove," Salem, Mass., Vice-President.

F. EURICH, Woodlawn, Toledo, O., Secretary and Treasurer

The Tenth Annual Convention will be held at St. Louis, date to be announced later.



**Wood Ashes as a Fertilizer.**

The frequent mention of the use of wood ashes as a fertilizing agent must have been observed by many, as well as the fact, long well known, of the beneficial results of their application in orchards generally. The reason is that the application of wood ashes as a fertilizer is no longer an experiment, but that their value on grass lands and lawns has been proven and is endorsed by many of the leading cemetery superintendents in the country. They contain mineral plant food in the most soluble and acceptable form, and the very great advantage they possess over ordinary manure is that they do not contain seeds of troublesome weeds; they are clean to handle and easy to apply and they are odorless. In confirmation of the statements as to the value of this material it would be easy to produce extracts from the reports of the leading authorities on agricultural matters, in which the records of the exhaustive experiments to determine actual facts are published, and which show conclusively that unleached hardwood ashes form a fertilizer of the highest excellence coupled with advantages found in very few others. For the large areas of grass land in our cemeteries and parks it is an especially desirable medium, and in fact to our own knowledge is being very largely used in many of our leading cemeteries. Its effect on grass is to ensure a vigorous and healthy growth, which can be maintained by a yearly light top dressing. It makes little difference whether the ashes are distributed in the fall or spring, only that it is advisable to get them on the ground as early as possible. Munroe, Lator & Co., of Oswego, N. Y., have developed the collection and care of Canadian Hardwood Unleached Ashes until by a matured system they are enabled to supply them in any quantities in the best condition and reliable in quality, and believing thoroughly in their fertilizing nature they have spared no pains to gather data in support of

their utility. A pamphlet is published on "Wood Ashes and their Use," by T. Grenier, author of several standard works on farm and garden matters, which can be had by addressing the firm as above, and mentioning PARK AND CEMETERY, and much useful information can be gleaned from its pages besides the conviction that it is worth giving wood ashes a trial, which the results will surely justify.

**Publisher's Department.**

NOTICE TO SUBSCRIBERS, If this notice is marked with a blue pencil it indicates that your subscription to PARK AND CEMETERY has expired and a renewal of same is solicited.

Park Commissioners and Cemetery trustees are requested to send us copies of their reports.

Photographs and descriptive sketches of interesting features in parks and cemeteries are solicited from our readers.

PARK AND CEMETERY wants the names of every park and cemetery official or employee who would be likely to be interested in this paper. To the many subscribers who have sent in such lists of names, we return our thanks. There are many more that we should hear from.

Subscribers are again reminded that we want brief notes on any feature of park or cemetery work that will be of general interest. PARK AND CEMETERY is the only publication of its class and earnestly solicits the co-operation of subscribers in making it a help to all identified with such work.

**RECEIVED.**

From Mr. W. Clouston, Supt. Hillside Cemetery, South Plainfield, N. J. view in cemetery of San Miniato, Florence, Italy.

RULES AND REGULATIONS of Westminster Cemetery, Philadelphia, Pa.

From Mr. Arthur W. Hobert, Secretary Lakewood Cemetery Association, Minneapolis, Minn., circulars of extracts from new state laws, and alterations in rules of the cemetery.

By the courtesy of Mr. Frank D. Willis, Sec'y. and Treas., Oakland Cemetery Association, St. Paul, Minn., extracts and comments on recent State Legislation, published in another column.

Sixth Annual Report of the Board of Park Commissioners, Paterson, N. J., for year ending April 1895. This report is tastefully illustrated with full page half tones, which display some beautiful park conditions.

**Personal.**

Mr. William P. Webb, founder of the Lorraine Cemetery, Baltimore, Md., and at the time of his death vice-president of

the company, died December 23, 1895, after an illness of nine months. He was buried in the family lot in Lorraine.

W. N. Rudd, Supt. Mt. Greenwood Cemetery, Mt. Greenwood, Ill., has been appointed a member of the executive committee of the Society of American Florists.

Robert Douglas, of Douglas & Son, nurserymen, Waukegan, Ill., well-known to many cemetery officials, is a striking personality, and can look back on a life paralleled by very few. Born on April 22, 1813 at Gateshead, on the Tyne, in England, he became very early interested in accounts of the vast tracts of forest land and wonderful natural attractions of North America. He reached Toronto, Canada, in 1837, and his sympathies led him to be involved in the war flurries of those times, and he participated in the battle of Toronto. Leaving for the West he settled in Waukegan and began the nursery business. He was one of the commissioners to investigate the forest wealth of the United States and in the course of this work he travelled far and wide over the face of the country. He has retired from business but is hale and hearty with his 82 years at his beautiful home at Waukegan.

Any one who has a garden will welcome the news that *American Gardening* (P. O. box 1697, New York) will greet its readers every week, commencing with the new volume in January. Though appearing twice as often, the price, \$1.00 a year, will not be altered. Readers can obtain a free specimen by sending a postal card request to the publishers.

We have received from Mr. Harlan T. Kelsey, Kawana, N. C., some beautiful specimens of Galax leaves and Leucothoe sprays. These beautiful southern evergreens were introduced sometime ago by Mr. Kelsey and have met with favor everywhere for decorative purposes. The Galax leaves are beautiful in outline and brilliant in color being a bright green and a rich bronze, with long pliant stems, and possessing the lasting qualities so essential in decorative materials. They are especially suitable for cemetery work in winter and have become very popular among florists for this purpose. At the funeral of the late George W. Childs in Philadelphia, one of the pieces which attracted most attention was a large wreath of Galax leaves and roses. Another point in their favor is the reasonable price at which they are sold, it is not at all surprising that they are becoming more popular than ivy for cemetery work. Mr. Kelsey will send samples of the leaves and price list to cemetery officials interested in using them.

The 1896 general catalogue of Ellwanger & Barry, Mount Hope Nurseries, Rochester, N. Y., has been received. It is an excellent production this year, and beyond a catalogue of fruit and ornamental trees, shrubs, roses, etc., it is worthy of a place on the shelves as a reference book. It is copiously illustrated, containing a large number of half tones of specimen trees and flowering shrubs, and two portraits of much interest: George Ellwanger and the late Patrick Barry. These two names are household words with the horticultural fraternity. Our readers are urged to send for a copy of this valuable catalogue and to mention PARK AND CEMETERY when doing so.



# PARK AND CEMETERY.

FORMERLY THE MODERN CEMETERY.

A Monthly Journal Devoted to Parks and Cemeteries.

R. J. HAIGHT, Publisher,  
334 Dearborn Street, CHICAGO.

Subscription \$1.00 a Year in Advance. Foreign Subscription \$1.50

VOL. V. CHICAGO, FEBRUARY, 1896. NO 12.

## CONTENTS.

EDITORIAL.....	197
PRACTICAL WORK IN THE CEMETERY.....	200
*CRAPO PARK, BURLINGTON, IA.....	201
*TERRACE STEPS, LINCOLN PARK, CHICAGO.....	202
*MOUNT ELLIOTT RECEIVING VAULT, DETROIT.—RE- SPECT FOR THE DEAD.....	203
*GARDEN PLANTS'—THEIR GEOGRAPHY, IV.....	204
STREET TREES .....	205
*HIMALAYAN PINE—PUBLIC PARKS AND RESERVATIONS	206
*EAST LINWOOD CEMETERY, BOONE, IA.....	208
ARBORETUM, PUGET SOUND UNIVERSITY.....	209
*AN ALGERIAN FOUNTAIN.—VELVETY LAWNS ..	210
CROWDED CEMETERIES IN LONDON.....	211
AUTHORITY TO DISINTER BODIES.....	212
PARK NOTES.....	213
CEMETERY NOTES.....	214
CORRESPONDENCE.....	215
PUBLISHERS DEPARTMENT.....	216

\*Illustrated.

IF it be true that the character of a community may be judged from its cemeteries, the idea may be easily extended to believe that besides the park, the cemetery can also be made an educator. Nature has always been the source and inspiration of higher life, for when man gets to understand her, in ever so slight a degree, her very wealth of wonder leads him ever on and ever upward; and the perfection of landscape effects as produced by those who, more or less, comprehend her laws of design and harmony, and such as are now being attempted in the modern cemetery idea, have an absolute tendency to inspire to higher thinking and purer reflection. We are only in the infancy of landscape work proper. For the most part in our northern latitudes, landscape designing has been mainly directed to summer effects, and it is only now practically dawning upon us that the other three seasons can be made to present beautiful pictures, as we learn to select those trees, shrubs and plants, which yielding their treasures of color and effect in the other seasons, in their turn, satisfy man's worship of the beautiful at all times.

SOME excellent suggestions in relation to the care and improvement of small cemeteries were given in the presidents address at the annual convention of the Onondaga County, N. Y., Cemetery Association, and the results of the formation of this association already justifies its organization. It is a melancholy fact that the majority of our rural and village cemeteries are in a sadly outrageous condition, displaying without question, positive neglect. It does seem strange, in a civilized community, and where it can be taken for granted that human grief is a sincere and permanent quantity, that it so soon loses its force in its relation to the cemetery wherein are deposited the remains of its object; and yet a little consideration offers a reason. What is everybody's business is nobody's, says the proverb, and from the fact that the care of ever so small a cemetery is too much for the individual, however devoted, the inference is that present conditions are due to a lack of organized effort, coupled with want of knowledge both of how to proceed, and how to take care of the cemetery when organization is effected. There are very few communities among whose members there could not be constituted a Board of Trustees, a Commission, Committee, or under whatever name a sufficient number of active and interested well wishers might not be gathered, and which would not have influence enough to call forth the necessary assistance from others interested. And this could be accomplished with very little red tape; indeed in many places the most active bodies at work in this reform movement are composed of women, organized for the special purpose of cemetery improvement and carrying on the work with the zeal and devotion characteristic of the sex. The first work of the board would be to decide what is to be done, the next to appoint a committee to do it. Should there be lack of experience as to what is necessary to be done to renovate a dilapidated, neglected, burial ground, the better plan might be to visit a neighboring well kept cemetery, the officers of which would undoubtedly gladly give all the necessary information. This obtained, appoint someone as superintendent, to be responsible to the board for active work, and with just a little money for the purchase



of some necessities and the help of interested labor, which might be reasonably expected of the lot owners, one season would see such changes and so much attractiveness compared with what was, that an interest would be created to carry the work on for all time. It is just the right time, and yet there is ample time, to make preparations for an active campaign this year in this direction. The work of cleaning up the debris, cutting away rank underbrush and brambles, and making general improvement can be begun right away, or whenever weather permits. Half the battle will be won, however, when the committee has all its plans arranged, for when the spring finally opens, to secure the best results for the year, no time must be lost in preliminaries. But let it be always borne in mind, no time is too late for the inauguration of active and energetic steps towards the better condition of our village cemeteries, for the conditions which prevail in most of them is a severe reflection on the intelligence and character of the community interested.

#### Practical Work in the Cemetery.

The question of the foundations for monuments, and other stone work in cemeteries, is one of great importance, and one that receives the utmost care and consideration in our larger cemeteries. Much of the dilapidation and general disorder witnessed in our smaller burial grounds can be largely attributed to lack of care and sometimes culpable negligence in this regard. The subject annually receives considerable attention at the convention of the Association of American Cemetery Superintendents, and the Richmond meeting of 1895 was no exception.

A question arose as to experience in grout foundations, composed of cement, sand and gravel, which by the way, should be more properly termed concrete. One method was to take one-third cement to two-thirds sand and gravel, thoroughly mixed and carefully rammed into place in layers, until the desired depth is attained. The prices for this class of foundation varied from 25 cents to 60 cents per cubic foot, according to size of foundation, the smaller ones being of course charged a higher price.

Another formula was 1 barrel Portland cement, 50 barrels crushed stone, 3 barrels good sharp sand.

From an engineering standpoint to which standard this class of work belongs, this would appear to promise a pretty weak material when conglomerated, and we should hardly be disposed to accept such for a permanent piece of work. But the material in which the foundation is sunk cuts a large figure in the strength of the artificial foundation to be

provided, the necessity of such being to distribute the load through a homogeneous material that no sinking or other change of position can possibly occur.

Unfortunately the severe winters to which some parts of the country are liable render special study necessary at certain places, but it must always be remembered by those not well posted on such matters, that the essential feature even in our coldest localities is to construct a foundation as nearly impervious to moisture as it is possible to get it, for it is not the temperature itself that causes the trouble, but the water in the foundation, freezing and thawing and disintegrating the mass.

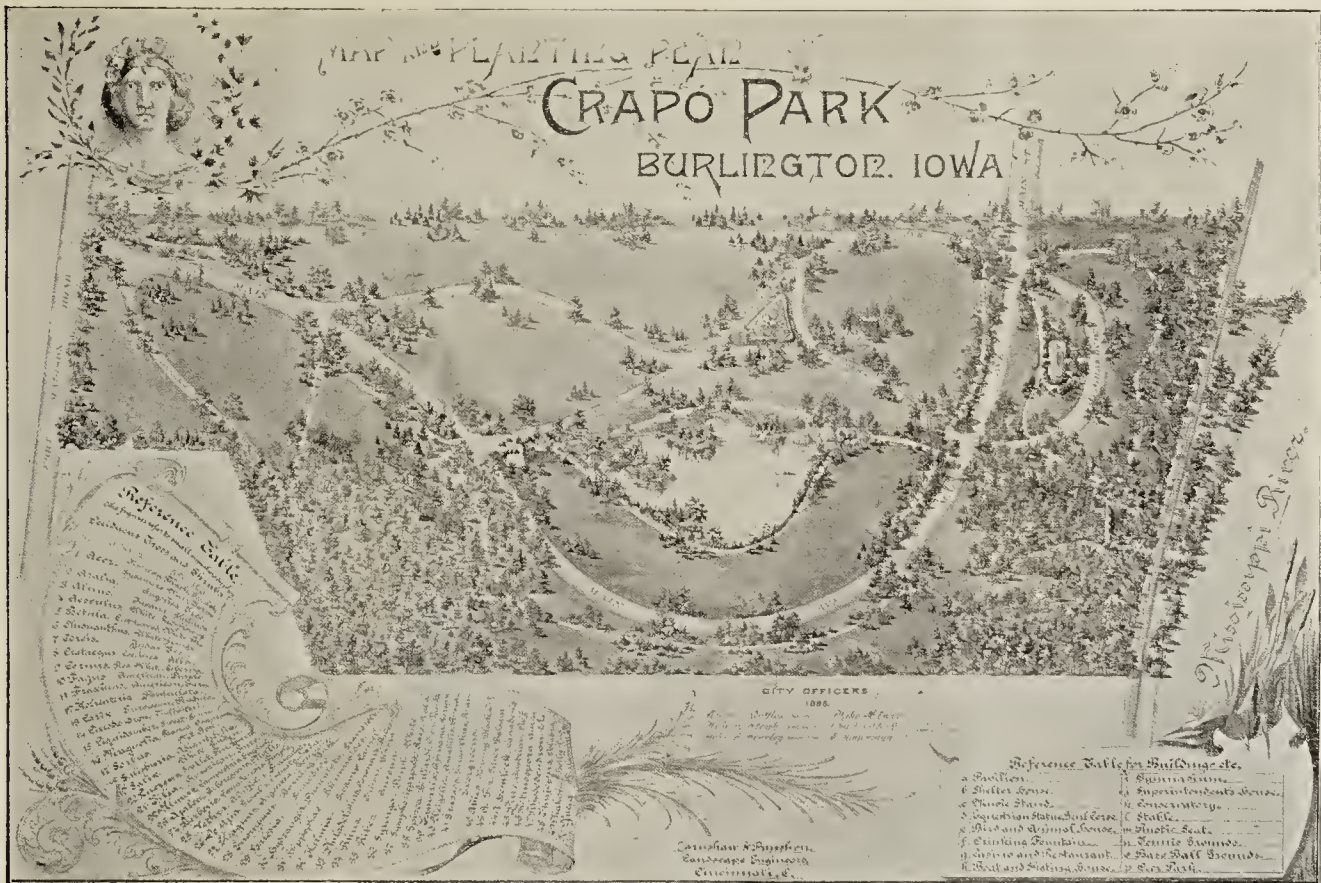
The questions of native versus Portland cement was given some attention. Portland cement has maintained such superiority in its main characteristics over other cements, that its extra cost has not stood much in the way of its use among those acquainted with its properties. The degree of excellence to which it has been brought, the constant study and experiment brought to bear upon it to increase its capabilities and efficiency, the high standard demanded for it by leading engineering authorities, when using it in large works, have given it a standard value and reliability which often determines its use when other cements might equally well serve the desired purpose.

When the same study and care in production and manufacture is established for the native cements, their already growing reputation will lead to a better knowledge of their qualities and the uses to which they are best adapted. The last few years have witnessed a rapid increase in their strength, and the breaking tests which they now stand with comparative reliability fix their value for certain uses.

All cements must be carefully treated to preserve their vitality, if stored for any length of time. Exposure to the air rapidly deteriorates them; they quickly absorb the moisture and their strength is impaired.

Great care should also be exercised in making the concrete or grout. The materials should be carefully mixed dry, and thoroughly at that, after which sufficient water should be added until with further mixing the right consistency is attained, and only sufficient of the materials should be mixed as can be immediately deposited in place and thoroughly tamped in layers say from six inches to a foot. Of course if the job is a large one, the mixing can be carried on continually until the required amount is deposited. Where good gravel and sharp sand is convenient, no better foundation could be obtained than one carefully made of concrete, nor at so moderate a cost,





**Crapo Park, Burlington, Ia.**

The illustration herewith is taken from a plan for improvement of Crapo Park, Burlington, Ia., designed by Messrs. Earnshaw & Punshon, Landscape Engineers, Cincinnati, O.

The tract contains one hundred acres, all having been under cultivation except about twenty acres of woodland. The topographical survey shows the tract to be substantially a plateau, from 120 to 150 feet above and adjoining the Mississippi river; the steep bank covered with forest trees and undergrowth, rises abruptly from the river, being indented in the southerly portion by two deep ravines, which, however, soon terminate westwardly in the upper levels, and on cleared land. In the southwest corner of the tract, about ten acres of oak timberland forms a large basin, the water therefrom flowing underground towards the river, and uniting with the waters of the famous Indian Spring, supplies a magnificent waterfall in a beautifully-wooded glen, located in the most northerly of the two ravines above referred to. Two smaller depressions are located in about the center of the ground. Charming views of the Mississippi River and Valley are afforded from many places on the tract—but the most picturesque and extensive range of view, is that obtained from the point of the bluff, near the north line of the farm which has been provided for by making Grandview Avenue fifty feet wide, with additional space opposite the Refectory for carriages. All classes and kinds of

improvement have been designed and arranged to realize all possible advantages from the beauty of the tract for park purposes. The site for the Refectory, or Restaurant, has been selected at the Rendezvous, to take in the magnificent prospect at that point and to be in proximity to the street car line. The Amusement and Picnic Grounds, with appropriate buildings, have been located in the oak grove, where there would be abundant shade, and plenty of room for the various games and rural attractions, as well as perfect safety for children. The general use of bicycles necessitates some careful provision and near the north line of the park a bicycle speedway is shown. A large lake supplied with city water will afford the means of enjoying the popular pleasures of boating and skating and is a grand feature in the landscape. There are 11,000 feet of avenues, and 9,400 feet of walks. The "Planting Plan" has been carefully arranged and in the selection of deciduous trees—shrubs and evergreens—as well as in their location and grouping, especial pains have been taken to secure successful growths by listing only the kinds adapted to the latitude, soil and climate; and by a proper combination, to insure harmony of foliage, and the most impressive views in all directions. Closets, Shelter-Houses, Drinking Fountains, etc., are shown at such places on the plan, as will best accommodate visitors to the Park, and the whole work is laid out to harmonize with advanced ideas in park landscape work.



**Terrace Steps With Vases, Lincoln Park, Chicago.**

The green terrace in front of the Palm House at Lincoln park, adds to its dignity and to its beauty, and the handsome stone stairs and balustrades that give access to it at the front as well as at the east and west sides, make fitting approaches in keeping with the formal surroundings.

The main terrace rises four feet and six inches above the drive, the first rise being two feet, dividing the stairs into two unequal parts and mak-



TERRACE STEPS, LINCOLN PARK, CHICAGO.

ing a much more effective approach than a single flight. The principal stairway, which rises directly in front of the main entrance to the Palm House from the gay flower garden that stretches away south from the terrace, is much broader than those at the sides, one of which is shown in our engraving, but the plan is nearly the same, differing only in minor details. The narrower flight was photographed because better adapted to show on a small scale the arrangement of steps, balustrades, vases and plants.

The balustrades are of boulders with a coping of Bedford stone on which large boulders are placed to prevent people from sitting there.

The shrubs growing on the terrace, that show so effectively against the balustrade, are *Berberis Thunbergii*, and it does well despite its exposed position to the north of the stone work.

The Agave used in square tubs is *A. Americana variegata* that is always handsome and appropriate in connection with architecture.

The terra cotta vases are twenty-six inches high, the inside dimensions being twenty-four by twenty-six inches. They are each year filled with light

loam enriched with bone meal, and about May 27, are planted with well rooted pot plants such as single and double Geraniums, *Petunia hybrida*, *Cuphea*, the yellow Daisy Queen of Belgium and *Calceolaria annua*, a pretty and odd little bright yellow annual that is always in bloom. *Lobelia Paxtoniana* and *Verbenas* are also used, together with such trailing plants as *Pilogyne suavis*, *Maurandia Barclayana*, *Vincas* both green and variegated, *Lophospermum scandens*, and *Tropœleum var. Bismarck*.

This is a good list to note carefully for use in vases that are exposed to full sunshine, for they all do well and these vases invariably have an overflowing luxuriance of vines and flowers that suggests fountains of verdure.

The bone meal used in the soil doubtless has a strong bearing on their thriftiness as it furnishes food that is drawn upon by the plants throughout the season. In this connection I recall seeing some remarkably pretty hanging baskets at Egandale, the charming summer home of Mr. W. C. Egan at Highland Park, Ill. They were filled with a wonderfully fine growth of *Maurandia* vines. Mr. Egan, who is an

enthusiastic and successful amateur gardener, attributed their free growth to a liberal portion of horn shavings and bone meal in the soil. The horn shavings for the immediate consumption of the plants on being set in the basket, and the meal to be taken as a regular diet during the entire summer.

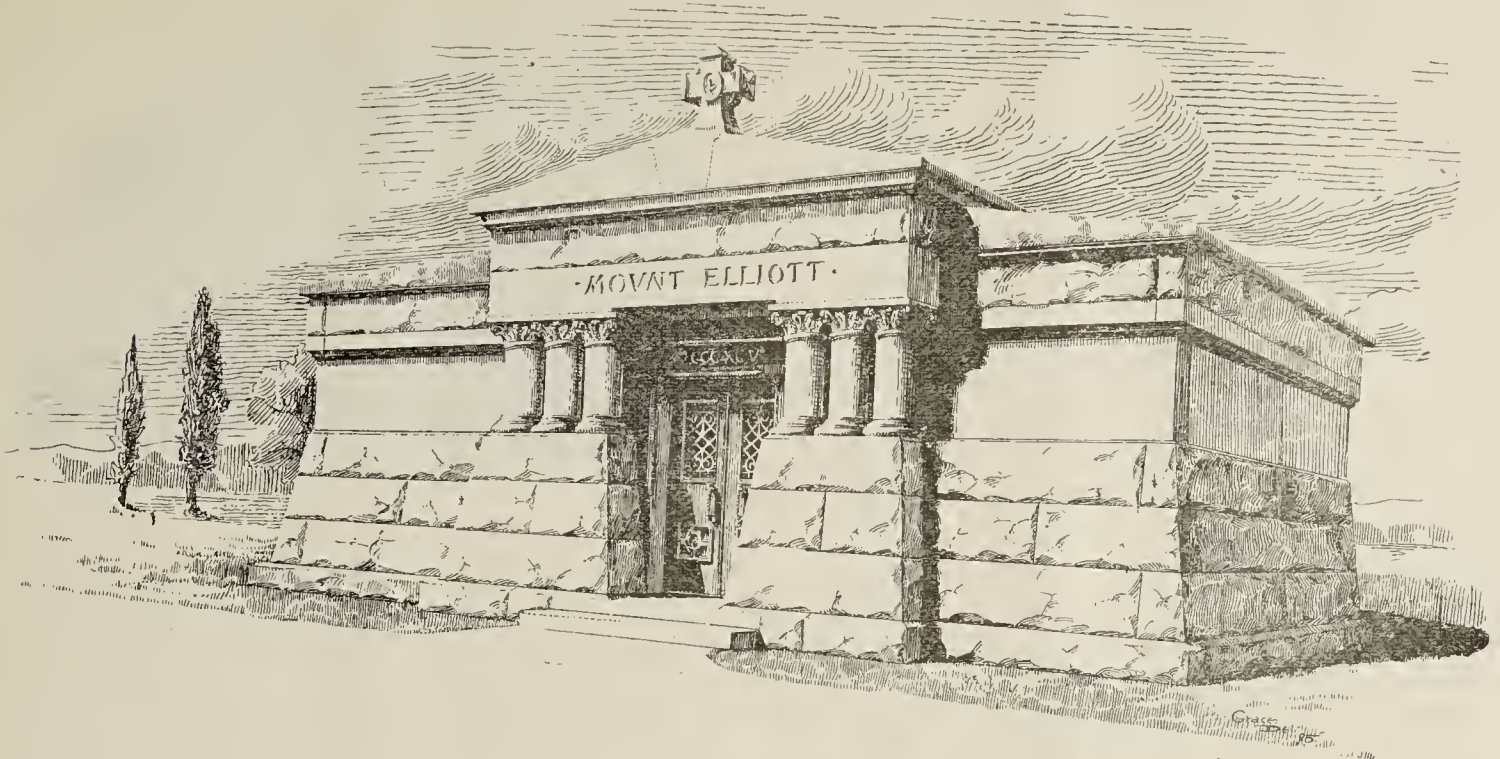
The beautiful turf that clothes the park terraces is from blue grass sod that was laid three years ago.

*Fanny Copley Seavey.*

**Receiving Vault, Mount Elliott Cemetery, Detroit, Mich.**

The new receiving vault of Mount Elliott Cemetery, Detroit, Mich., is built of Barre granite, and forms a substantial and imposing pile, covering an area of about 30 by 26 feet, 16 feet high. The design, which is by Mr. F. A. Grace, architect, is well displayed on the next page. With the exception of the crypts, of a capacity for 60 bodies, which are constructed of limestone and Italian marble, and the interior finish of marble and encaustic tiling, the whole structure is of granite, rock-face and fine hammered work as can be seen by the illustration. The granite roof is constructed of some heavy stones. The wing caps are 18 feet 5 inches





RECEIVING VAULT, MOUNT ELLIOTT CEMETERY, DETROIT, MICH.

by 8 feet 6 inches, by 1 foot 8 inches. The next stones are 20 feet 2 inches by 5 feet wide by 1 foot 8 inches and the key is 4 feet 2 inches deep.

Great care has been taken in the design to provide for ventilation and drainage. An air space extends under and at the back of the crypts to which air is admitted through ventilators, which passing through in a continuous current, finds its exit through

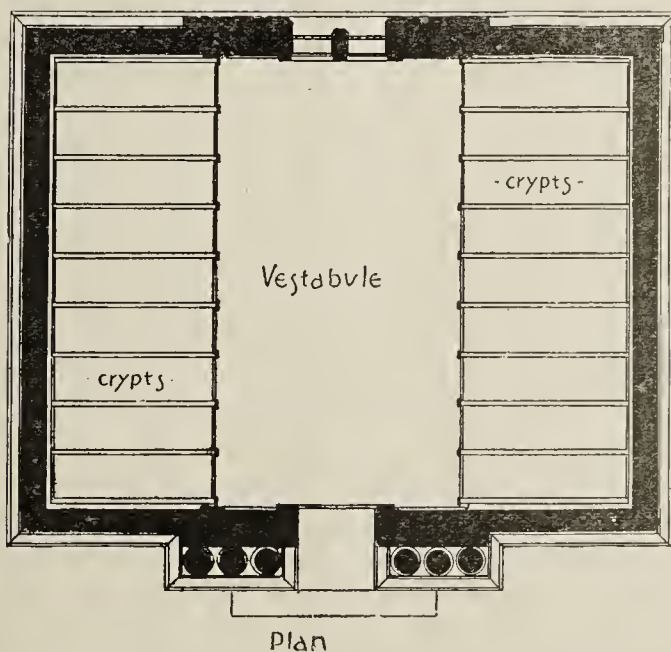
The contractors were the Harrison Granite Co., of Chicago and Barre, Vt.

**Respect for the Dead.**

Our respect for the dead, when they are *just* dead is something wonderful, and the way we show it more wonderful still. We show it with black feathers and black horses; we show it with black dresses and black heraldries; we show it with costly obelisks and sculptures of sorrow, which spoil half of our most beautiful cathedrals. We show it with frightful gratings and vaults, and lids of dismal stone, in the midst of the quiet grass; and last, and not least, we show it by permitting ourselves to tell any number of lies we think amiable or credible, in the epitaph.

\* \* \*

Now, this being one of the most complete and special ways of wasting money;—no money being less productive of good, or of any percentage whatever, than that which we shake away from the ends of undertaker's plumes—it is of course the duty of all good economists, and kind persons, to prove and proclaim continually, to the poor as well as the rich, that respect for the dead is not really shown by laying great stones on them to tell us where they are laid; but by remembering where they are laid, without a stone to help us; trusting them to the sacred grass and saddened flowers; and still more, that respect and love are shown to them, not by great monuments to them which we build with *our* hands, but by letting the monuments stand which they build with *their own*.—*John Ruskin.*



the upper ventilators provided in the roof. The crypts have a fall from front to rear and the drainage is carried away by suitably arranged ducts at the back. Two small windows at the rear of the structure, as shown in the plan, serve for lighting the interior of the vault.



## Garden Plants.—Their Geography.—IV.

PARIETALES. (Continued.)

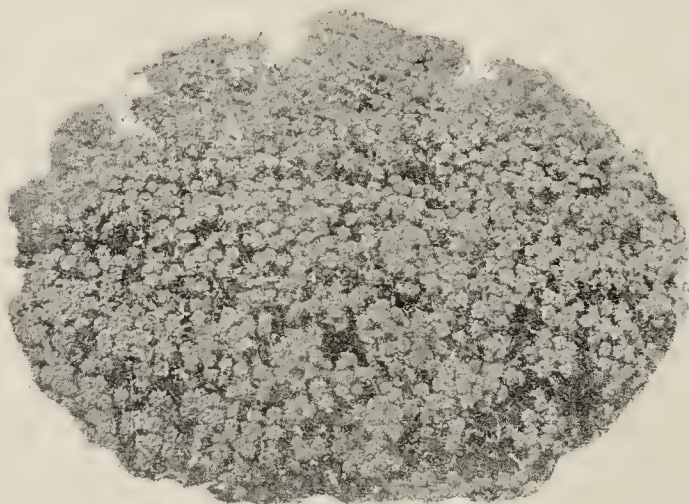
THE PAPAVER, BRASSICA, AND VIOLA ALLIANCE.

*Cardamine* has 75 species distributed over the temperate and cold regions of both hemispheres. *C. pratensis* is the common British "Cuckoo flower," found also in New Jersey, so named because its flowers appear with the English Cuckoo. The blossoms are lilac-pink, some are double and some are white. *C. latifolia* is a larger growing south European kind with purple flowers. Both prefer moist situations. *C. amara* is another British species with cream colored flowers always found in marshy places. There are a number of dwarf white flowered species both native and exotic, which are perhaps worth remembering for the swampy margins of artificial ponds.

*Lunaria annua* is the "honesty" so called and well known, but the white variety is less common. *L. rediviva* has blue flowers and is perennial. These are the only species. The botanists have made one of their sagacious changes in the name of *L. biennis*.

*Aubretia* has 7 species found in Persia, and through the Eastern and Northern parts of the Mediterranean region as far west as Italy. They are dwarf, mostly purple flowered plants, largely used in Europe for spring flowering. Several varieties are kept in nurseries.

*Alyssum* is distributed in 100 species over Europe and Northern Africa. They are annuals or perennials. *A. saxatile* with bright yellow flowers is sometimes seen, and where it is hardy it is well worth growing. It flowers in spring. The sweet alyssum so commonly grown by florists is wild both in Europe and Asia minor, and sometimes becomes a weed in British gardens. There is a var-



ALYSSUM SAXATILE.

iegated one seldom seen now; these plants often suffer a good deal from the turnip fly.

*Draba* is an extensive genus of herbaceous, or



IBERIS SEMPERVIVENS.

as they are regarded, alpine plants. There are perennials, biennials, and annuals among them, mostly with yellow or white flowers. They vary a good deal according to locality, and consequently botanists have loaded them down with names. The common British "Witlow grass," *D. Aizoides*, with a curious growth, and bright yellow flowers in May is sometimes kept in nurseries. The species are distributed over the temperate and sub-arctic regions of the northern hemisphere, and the southernmost Andes. A few of them may be used for the clothing of small rock-works.

*Hesperis*, "Garden Rocket" has twenty-two species distributed over Europe and the northern and western parts of Asia. *H. matronalis* is often found wild in England. It is also found occasionally in the Atlantic states, evidently escaped from gardens. There are a number of varieties, red, purple, white and striped. The flowers are sometimes fragrant after sundown.

*Erysimum* has eighty species distributed over the temperate parts of the Northern Hemisphere. It is about the best substitute we have for wall flowers in hardy plants. *E. pulchellum*, with lemon colored flowers and quite showy, is sometimes seen. *E. Perowskianum* is an annual from the Caucasus, with showy orange flowers.

*Brassica* is the cabbage genus. There are eighty-five or more good species. They are mentioned here because they include the very handsome variegated leaved forms. They have much the habit of the Scotch curled Kales, but with beautiful colors like coleus.

*Iberis*, "Candytuft" has twenty species, nearly all from the Mediterranean regions and Asia Minor. Some are shrubby, low evergreens, some herbaceous, and some annual. Many varieties are highly prized and well known garden plants, others again are uncommon.

*Cakile* has two species, one European, one





CLEOME SPINOSA.

American. These "sea rockets" are rarely seen in gardens as they are difficult to grow away from the sea beaches. The British *C. maritima* is pretty.

*Cleome* has ninety species distributed over the temperate regions. They are mostly annuals, but a few are shrubby. *C. rosea*, *C. speciosissima* and a few others are in cultivation. *C. pungens* is found wild in places along the lower Delaware. These and many other plants of like character should be grown in masses. Two or three flowers on a single plant are not sufficiently effective, except in small gardens.

*Reseda* has thirty species mostly from the regions of the Mediterranean. There are larger, growing yellowish and white species sometimes seen in gardens, but none have the popularity of the odorous though dull colored mignonette.

*Cistus* has twenty-five species mostly from Mediterranean regions. They bear a host of names. *C. laurifolius* is perhaps the hardiest, and has sometimes stood the winters of Philadelphia. They should be tried along the coasts further south as they are maritime in their preferences. They are summer flowering and fugitive but quite pretty.

*Helianthemum* is a trifle more extensive as to species having perhaps thirty-five, and far more names. They are found all over the world in shrubby and annual varieties. They are pretty little things, these Rock-roses, with their yellow or white spotted fugitive flowers. There are several species native to both Britain and America. They prefer gravelly or sandy soils.

*Viola*, "violets" and "pansies" have 150 species scattered over the earth, mostly in temperate regions. They are so popular and well known that they need but little said about them. The sweet garden varieties are derived from *Viola odorata*, "violets," and from *Viola tricolor*, "heartsease," with *V. lutea*, "yellow heartsease" which are the originals of the splendid race of garden pansies. We have a great many handsome native species and *V. pedata*, "bird-foot-violet" and its varieties are certainly worthy of more attention than they receive, both from the spring-gardener and the hybridist. It is not too much to say that the coloring of this species is as rich as any in the genus.

*Idesia*, is an arborescent wanderer from the tropical representatives of the parietal alliance. It is a monotypic tree from Japan with large leaves.

It will probably be largely confined to the south, at any rate young plants have seemed somewhat tender at Philadelphia.

---

#### Street Trees.

The somewhat exaggerated desire on the part of local authorities for planting street trees—a most desirable act in broad streets and where there are no forecourt gardens—is likely to seriously injure trees of very pleasing character previously planted privately in gardens, and in that way to shut out or destroy one of the most pleasing of suburban aspects. Street trees must of necessity be of one kind, and in that respect many of them soon become very monotonous; then they will grow large in time, let the kind be what it may. To check that evil it is necessary later to use the saw and the knife largely, and thus these trees must ultimately either be converted into mop-heads, be kept unduly thin, or be allowed to grow too large, and in that way not only shut out from the adjoining houses needful light and air, but also so much from the forecourt gardens, that these are robbed of all charm, and trees, shrubs and flowers become drawn and useless. On the other hand, a suburban street or road in which there are on either side forecourts of some 20 feet in depth usually have some few trees planted in them. It is in this case that variety exhibits so much that is pleasing, although that satisfaction is modified when here and there some foolish or thoughtless person plants American Oaks, Sycamores, Planes, Horse Chestnuts or similar large trees that outgrow space and everything else in the most unpleasant fashion. Perhaps it would seem an undue interference with personal liberty, but as we endure much in that direction for the general good now, it might be as well to grant local authorities some power to control tree-planting within 20 feet of the street or road, so as to check the putting in of any kinds that made growth far beyond the needs of the case. Equally, on the other hand, it would be well did such local authority offer every encouragement to the planting of suitable trees in these forecourt gardens. What wondrous beauty will flowering trees give to suburban streets in the spring and summer. Most of these also are of moderate growth, needing little pruning, and if some be given, in no case producing distorted heads. There are Almonds, double-flowering Peaches, Cherries and Thorns, Laburnums, Lilacs grown as trees, Crabs, or Pyruses of diverse varieties, Mountain Ash for berries and Sumachs for foliage, all most beautiful, though in a street no one wishes to see every tree a flowering one. *A. D. in The Garden.*



### The Himalayan Pine.

Among the numerous members of the pine family, it would be difficult to find one more beautiful and useful than the Himalayan, *Pinus excelsa*, also known as the Bhotan pine. There are but few others possessing the many good points of this one, and it is no wonder that it is such a universal favorite. The one shown in the picture is one of several in Fairmount Park, Philadelphia. Beautiful as it is, it is yet comparatively a young tree, being about



BHOTAN PINE.—*Pinus excelsa*.

twenty feet in height, and as it becomes fully developed there is rather more of a drooping tendency in the branches, and it is this, with its beautiful needles, which gives it such a charm. In color the needles are of a glaucous green, slender and soft, drooping so much that it gives to the tree a weeping character. On large grounds it is much in place in certain positions, and for cemetery planting it is unequaled. When it gets to some age it bears cones, which, while modeled after those of our native white pine, are very much larger. These cones are by no means unattractive, especially when they open in late summer. Although pines with rigid needles are indispensable for certain positions on ones grounds, my preferences are always for pines with soft foliage, such as this one has. As is the case with most all pines, as the tree gets large the lower branches become decumbent, and, sweeping the ground as they then do, present the tree in a shape in which it is usually much admired. As

mentioned already, the cones resemble the white pine very much. The resemblance does not stop there. The silvery green foliage and the general appearance also reminds one of that species, only that this one, *excelsa*, is infinitely better. Mr. Chas. H. Miller, the park landscape gardener, remarks that it is one of a few pines which transplant better than others. Here again is something which seems to bespeak some relationship to the white pine. Both sorts have a great many more small roots than pines usually have, and all large planters are aware that there is no common pine can be transplanted with fewer losses than the white. I have seen lots of over a hundred each and five to six feet high transplanted many a time, with but the loss of a tree or two, and yet with no extra precaution in the matter. Had it been, say Scotch or Austrian pine, there would have been the loss of many more, for these kinds are in the class with those that make but a few forked roots. The photograph is of a tree which is in a portion of the park lying between Horticultural Hall and George's Hill, a favorite place for the thousands who throng the park on favorable days. The pretty cottage is the one erected by Ohio at the time of the Centennial in 1876, and it is still the Ohio Building by the residents of the city who remember its erection. The fine oak which appears almost to embower it is the *Quercus tinctoria*. The shrubbery in front is composed of a great variety and nestling in the midst of it are a few of the Scotch broom, *Genista scoparia*, which hereabouts is quite hardy. The airy looking deciduous tree to the left, across the path, is wild cherry, *Cerasus serotina*.

*Joseph Meehan.*

### Public Parks and Reservations.

The Interstate Park Commission of Minnesota is taking active steps to awake public interest in the Interstate Park at the Dalles of the St. Croix. As a means of arousing this interest lectures have been provided, from one of which delivered at Taylor's Falls by Mr. Frank H. Nutter, Landscape Architect, Minneapolis, Minn., the following extracts from advance sheets are given. The author first gave at length a history of parks and their treatment from early times, and then said:

But you may ask, what bearing may these facts, interesting or not as they may be in themselves, have on the project in which we are more directly concerned? I think a very direct one in that they go to show that these parks and reservations are called for more and more as the years go by, to meet a want that is tangible and making itself increasingly felt among the people, and they are not to be relegated to the domain of fancies as some of their



opponents would claim, or even to be classed among luxuries, all right, perhaps, when every other so-called practical want is satisfied, but whether that time be now or a century hence, it matters little; instead of this you may boldly claim that as civilization has shown that the "old oaken bucket" must give way to the system of water works, and the cess-pool in each citizen's back yard to the modern methods of sewerage, so the present tendency to congregate in the large cities and towns with their health and nerve destroying characteristics, must be offset by the preservation of such localities as may be especially adapted to the purpose by their natural beauties, that there may be places to which the tired denizens of the cities may retreat for rest of mind and body, and where by means of out door recreation, new strength may be gained for daily work; and so when you ask that public moneys be devoted to this purpose it is not merely as a matter of local improvement but for an object in which all those inhabitants of the two adjacent States or of the world at large who may in future years be enabled to visit the spot are directly interested; and as the health either of the physical or moral nature of any person has its influence on those with whom he comes in contact, its results will be ever widening till we cannot set a limit to them.

\* \* \*

In locating a public park a question of first importance, but one rarely given much consideration, is that of boundary lines, which are generally left to settle themselves as temporary convenience may dictate; and it is discovered too late that instead of some tract, that for its beauty of location or relation to the rest of the park should have been secured at all hazards, we have some land that at best involves unnecessary expense in bringing it into harmony with the balance.

\* \* \*

As to the treatment of the Park, when it comes to improvements there will doubtless be some difference of opinion, and in some minds at the present day, there seems to be as great a disinclination to commit the designing of a reservation of this kind to a Landscape Architect as there used to be in the olden time among some classes to committing the care of their bodily health to a regularly educated physician or surgeon, because perforce he must be allied with Satan. To be sure there are quacks and shysters in all professions and a Landscape Gardener whose sole idea of art is to fill a lawn with cannas and coleus or to construct a world or a horse of echeverias, might in his efforts to decorate only succeed in desecrating the landscape; still that does not prove false the assertion that the improvement of such a park should be based on a

design which has been carefully studied and in which the end is clearly seen from the beginning. Anything strikingly artificial in such a place as this must have the effect of a discordant note, but in any locality where crowds do gather certain precautions for their own safety and the preservation of the natural features must be taken and it is therefore a choice of evils.

\* \* \*

The improvements to be made may be divided into two classes,—first, those intended to restore or preserve the natural features of the park, or to make them more prominent, and second, to make the features safely accessible to visitors.

In the first class I would arrange them as follows:—Proper regulations and police protection to save what you now have and whatever may be done in the way of planting, etc. It looks to many as very unreasonable to be denied the privilege of cutting a walking stick, a branch of a flowering shrub, a bouquet of ferns and wild flowers or of chipping off a specimen of trap rock for a memento of a pleasant excursion, for they forget the old proverb "that many a little makes a mickle," and that it is not the matter of one little souvenir, but of the tens and hundreds of thousands that would in the course of time demand the same privilege.

\* \* \*

Next, and first in the line of manual work is the cleaning of the ground by the removal of the dead trees, stumps and other debris which now interfere with the new growth which is starting, and is also a source of danger from fires. The standing timber also needs inspecting and often times a little intelligent surgical treatment will start a feeble and apparently dying tree into vigorous growth again, or a judicious thinning out will add much to the health and appearance of the woodland. It is to be regretted of course that along the river gorge so large a proportion of the old pine growth has been removed, but whenever land is owned by private parties nothing else can be reasonably expected, for it is the source of the owner's livelihood, and it must be made to yield its income as in any other lines of business.

There is in many minds a great misunderstanding as to the true intent of Forestry as a practical pursuit, and the advocates of such treatment of the timbered sections of the Northwest are too often held up to scorn by their opponents as those who would at once put an end to all the lumbering interests which are such an important element in the prosperity of our State.

This is a great mistake, as the true theory of forestry is that each and every tree shall be cut at that period in its growth when it is at its highest value.



**East Linwood Cemetery, Boone, Iowa.**

In the summer of 1895 certain citizens of Boone, Iowa, realizing that a new place of burial for use of the community was an absolute necessity, purchased thirty acres of land, about one mile southwest of the city, and immediately southeast of the old cemetery, for that purpose.

Their plan of organization was as follows: A stock company with \$12,000 paid up capital was formed, \$9,500 was paid for the land, the balance to be devoted to improving and developing the grounds. The articles of incorporation provide that the stock be non-assessable and the indebtedness is limited to one dollar.

Of the receipts from lot sales, one half is to be distributed among the stockholders, distribution to be made whenever there is a sum in the treasury equal to \$5.00 for each share of stock. Of the balance  $\frac{1}{2}$  (or 25 per cent of gross sales) goes to the City of Boone as Trustee to form what will be known as a perpetual fund to be invested in bonds and the interest to

compound. The balance of the receipts from lot sales is to be used in maintaining and caring for the grounds during the life of the Corporation, which is chartered for twenty years. At expiration of twenty years, all unsold property is to be turned over to the City of Boone, and the City is to assume the management and care from that date. The perpetuity fund is expected by





that time to be sufficiently large so that the interest itself, will be ample to maintain the grounds. It is presumed that before the expiration of the charter, the incorporators will have sold sufficient ground to repay them the amount of their investment with interest.

All deeds must be signed by the City Clerk, but before he signs them the 25 per cent of price must be paid into the perpetuity fund. All lots sold must be paid for in full before being occupied.

The city must receive not less than fifty dollars in any one year, and in case of default are empowered to immediately take charge of the grounds. Lots range in price from \$15 upwards, according to size and location.

The old cemetery (10 acres) has been in use as a place of burial since 1866 and during that time there has been interred therein about 3500 bodies, and as is the case with nearly all village cemeteries was sadly neglected, lots were sold and resold, burials made on wrong lots, and in fact a most reprehensible state of confusion has existed for some years.

Seeing the trouble caused by lack of management and proper records, the promoters of the new cemetery have taken all precautions possible to prevent a recurrence of it.

Before offering any portion of the grounds for sale the entire ground will be surveyed and laid out in sections and platted into lots.

Arthur W. Hobert, Sec'y. and Supt. of Lakewood Cemetery, Minneapolis, has made several trips to Boone for the purpose of studying the ground and has furnished plans as shown, which have been adopted by the directors.

The ground selected is a fine rolling piece with a beautifully wooded ravine cutting through it from east to west, a short distance to the left of the main entrance. It is proposed to reserve the section surrounding the ravine for purely ornamental or Park purposes, and at present to plat and sell from the portion lying north of it.

This part of the ground is absolutely free from trees or undergrowth and will be planted and beautified entirely according to Mr. Hobert's ideas. The right of way of the C. & N. W. R. R. which extends along the southwest border of the grounds will be entirely hidden by thickly planted trees and shrubs.

The aim is to eventually connect Old Linwood with East Linwood by a bridge across Honey Creek as shown on plan, and as the purchase includes a small triangular piece lying west of the creek, this will probably be platted and ornamented to correspond with the portion lying east of the creek. Space has been reserved at the west end of Section C. for

a side hill receiving tomb which will be built soon. Proper office and waiting rooms will be erected near main entrance.

Grading was commenced in October and already two sections are prepared for sale. There will be no walks cut out through the sections nor around lots, but all work will be done on the lawn plan. The lots range in size from 4 x 10 for single burial to 24 x 24, and are sold at such a reasonable price as to be within reach of all. A free burial plat is also provided for the use of paupers and unknown dead.

#### Arboretum, Puget Sound University.

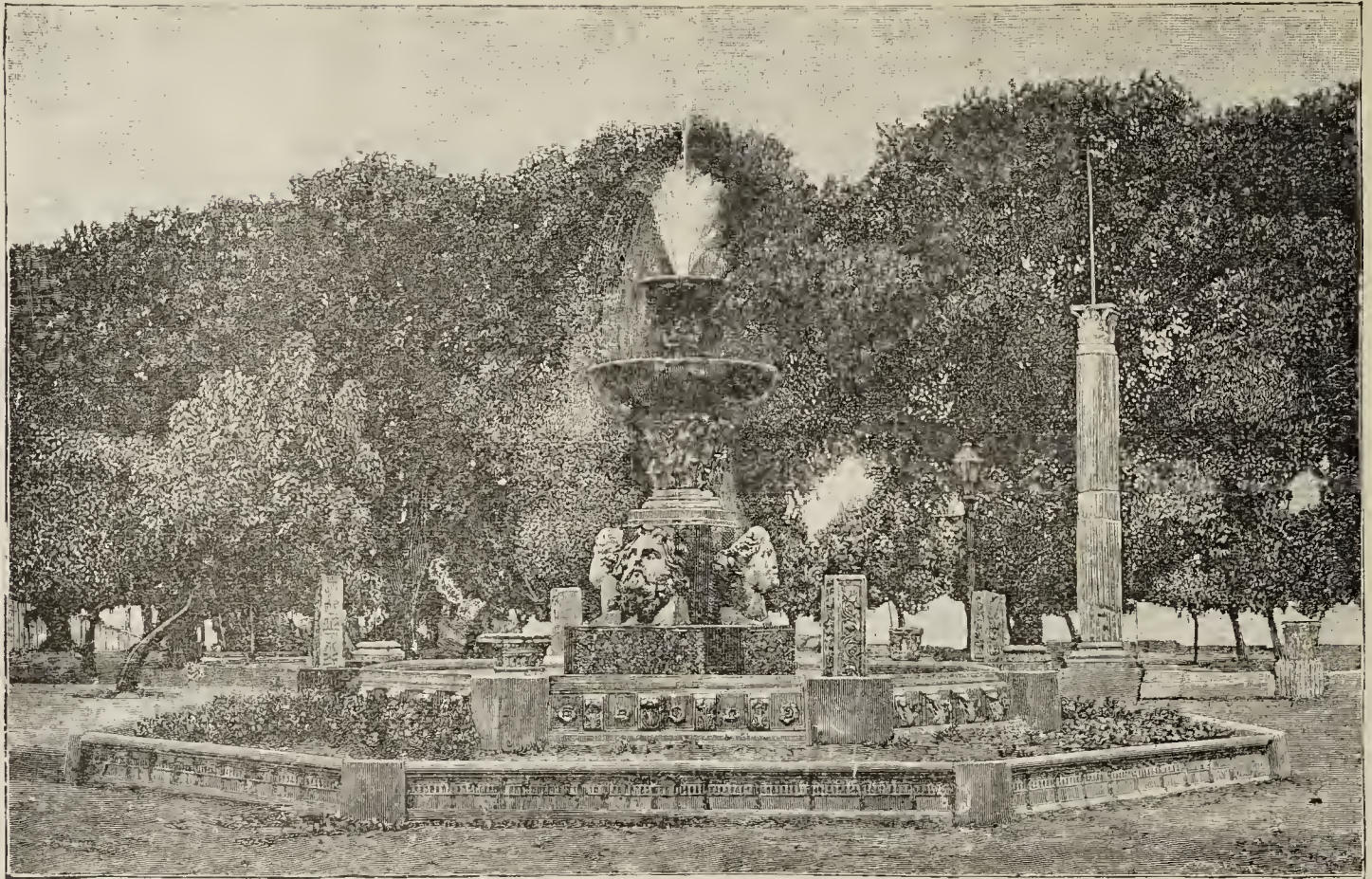
The advantages of the botanical park are becoming recognized at all centres of learning. The nucleus of what may become a valuable and important addition to the educational facilities of the state of Washington, is located upon the lands of Puget Sound University, immediately southwest of the city of Tacoma. The University Residence Park consists of over 1200 acres of land which as time goes on, is to be laid out into parks and pleasure grounds and to contain in natural landscape a complete system for the study of trees, shrubs, and other hardy plants.

This museum of trees has at present some 10,000 young plants in 250 varieties, containing many rare and choice specimens from European collections. The climatic conditions of this part of the country are especially adapted to the successful care of a large variety, and the 200 acres devoted to the museum of trees is so situated as to secure suitable soil and location for the extensive collection it is designed to accumulate and cultivate.

The surroundings, natural scenery and opportunities will open a large field for practical study, investigation and experiments.

As Mr. E. O. Schwagerl, the landscape engineer, says: "Few realize the value of this department to all classes of students attending the university. Indeed there will be few who will not find most instructive as well as interesting illustrations in some of the many plants thus collected from near and far. In the exhibition of individual varieties and in their display of beauty in either their trunk, limb, or foliage, flower or fruit, or in the scenes and views which they combine to create as factors in landscape architecture. While the dendological student will study the science of their life and use to the great world of chemistry, manufacture, art and architecture, all students and residents will enjoy the charm and harmony of nature and her ever changeful lights and shades of different hues which make the seasons ever varying."





THE ROMAN FOUNTAIN AT CHERCHELL, ALGERIA.—FROM *L' Illustration*

#### An Algerian Fountain.

Not very long ago there was erected in the public square at Cherchell in Algeria, a fountain composed entirely of Roman ruins found at Cherchell or in its immediate neighborhood. This fountain deserves notice on account of its elegance and for its distinctive characteristics. To M. Munkel, a citizen of Cherchell is due the honor of having designed and carried out the work.

The following description in connection with the illustration will give a very clear idea of its peculiar features. Against its four faces of a cement cube four colossal heads have been placed, which were formerly in the museum at Cherchell. The most remarkable of these heads is that of a man which, according to various archaeologists, represents Ocean, Neptune, Jupiter or Ptolemy; the other three heads with wavy and somewhat disturbed hair represent nymphs.

Above the cement cube, or base, against which these four heads have been placed, is a capital of striking workmanship, upon which rests a great marble basin, or vase, which in turn supports a second capital of much smaller size than the one below, which also supports a marble basin, of much smaller size than the first. From this last springs the stream of water, which under a sky like that of Algeria, and in so brilliant a sun, is magnificently beautiful.

The great octagon basin is formed of pieces of cornices admirably adorned with leaf carving, and at the eight angles are placed four small pieces of square columns, two column bases, and two small capitals. From *L' Illustration*.

#### Velvety Lawns.

To dwell upon the fact that a vigorous growth of grasses cannot be obtained on soils that have become exhausted is not necessary, but it is essential to direct special attention to the fact that the application of manure to a lawn requires the greatest care to insure its having a beneficial effect. The importance of this will be fully appreciated when it is remembered that the herbage is of a complex character, and includes both gramineous and leguminous plants; and that as these differ materially in their food requirements, the peculiarities of each class must be duly considered. If this is not done, one or the other will assuredly predominate. Without entering at length into the scientific aspect of the question, it may be well to point out that certain manures are more favorable to some plants forming the herbage than to others, and that when one kind of manure only is used, the plants for which it is specially adapted will grow with undue vigor and crowd out the others. For instance, dressings of wood ashes and kainit, in consequence of the potash they contain, and of gypsum, by rea-



son of its power of rendering the potash in the soil available as plant food, have a favorable influence upon the growth of the clovers. On the other hand, nitrogenous manures, as nitrate of soda and sulphate of ammonia, promote the growth of grasses, and as a proper balance of grasses and clovers is essential to the formation of a velvety turf, it is important that the requirements of both classes be properly met. It therefore follows that, when artificial fertilizers are used, they should contain phosphates, potash, and nitrogen; superphosphates or bone meal, kainit, and nitrate of soda will give these constituents and in proper proportions if superphosphate and kainit are mixed in the proportion of two to one and applied at the rate of three pounds to the square rod, and subsequently a dressing of nitrate of soda be applied at the rate of one pound to the same area. The mixture may be applied late in the autumn or in February, but the dressing of nitrate should not be given until the end of March or beginning of April. Although these articles supply the food required by the various plants, they do not supersede stable or farmyard manure, as the latter not only contains all the food constituents necessary, but act as a mulch, and by increasing the humus near the surface materially assists in conserving the moisture about the roots. As usually applied to lawns, natural manures have an objectional appearance for a considerable period, and we should suggest that instead of spreading the manure over the lawn in a half rotted state, in accordance with the practice which obtains in dressing pastures, it should be dried sufficiently to permit its passage through a sieve and be then mixed with equal quantities of powdery leaf mould and old potting soil. This mixture spread over the turf in the autumn will quickly disappear, and prove of great value in promoting the growth of the grasses and clovers, and preventing the lawn being burnt up during dry weather.—*Scientific American*.

#### Some Druidical Stones.

Old Cotswold Hills in Gloucestershire, England, though steep and long, will well repay the climber who perseveres in reaching the summit, says Carrie Levina Hodsdon.

There he will find the famous Rollerick stones. These stones are longer than they are broad, and stand upright in such a manner as to describe a circle, which is thirty-three yards in diameter. Inside the circle is a group of scraggy fir trees.

Two or three hundred yards to the north is a taller and larger stone, which is known as the "King's Stone," and at about the same distance to the southeast are five more, two of which are lying down. To these are given the name of "The

Whispering Knights," so called, doubtless, from the fact that they are placed in such a position that as the wind plays around them a sound as of whispering comes distinctly to the ears.

How or why such stones should be found here is more or less of a mystery. The most generally accepted opinion is that they form part of a Druidical circle, consisting of about sixty stones. "The Whispering Knights" are five stones of what is supposed to be an overturned cromlech.

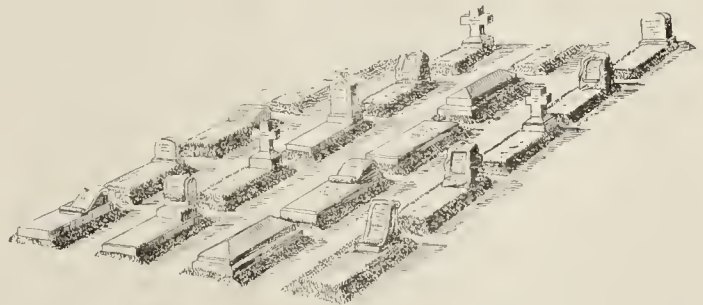
Other students cling to the idea that the whole series of stones were placed there to commemorate a victory won by Rollo.

Of course there is a tradition connected with these stones, which runs as follows: Years ago a Danish prince came over to England with the amiable intention of becoming its possessor. He landed at Dover, consulted a prophet, and set out for Long Compton. Leaving his men at the spot where the fir trees now are, he walked forward and was turned into stone. His five knights shared the same fate.

Thus ended the little excursion party of the Danish prince, but the five knights are still whispering over their sad fate.

#### Crowded Cemeteries of London. England.

The necessity of control of monuments in the public or parochial cemeteries of London, by the cemetery officials, will be obvious from a glance at the accompanying sketch. The old burial grounds are so crowded that the space between adjoining graves has become very limited, compelling the arrangement shown, where a row of upright stones



and a row of flat ones alternate. The sketch, however, does not altogether convey the idea intended, the draughtsman failing to comprehend the exact situation. Mr. J. A. Randall, Morden Marble & Stone Works, London, informs us that the space between adjoining monuments in which the proposed memorial is to be erected is fully occupied by a stone measuring six feet six inches by two feet six inches. If upright memorials were allowed in every case there would be no means of reaching any grave beyond the first row." Hence the authorities, without exception, demand, before any work is proceeded with, a sketch of the proposed memorial as well as a copy of the proposed inscription.



**Authority to Disinter Bodies.**

A trial of the greatest interest and importance to Cemetery officials has just been concluded in the Circuit Court, Chicago, before Judge Baker.

In the year 1891 Mr. C. C. Cushing a resident of Hinsdale, a suburb of Chicago, lost a child with diphtheria, the body being interred in a lot belonging to his brother-in-law, in Oak Forest Cemetery, of which Mr. G. K. Wright is the superintendent. After the remains had been buried about a year, Mr. Cushing desired to have them removed to his family lot in Oakwoods, Chicago. Mr. Wright refused permission stating that he had written the State Board of Health and had received a reply, saying that as the body had died of contagious disease it could not be removed to another burial ground.

Mr. Cushing then took the matter into his own hands, and had the body disinterred at night, put into a wagon and taken across country to Oakwoods Cemetery, where they arrived early next day. The superintendent of the latter cemetery refused admission of the body to that burial ground and it was carted off and secreted in the city. The Supt. of Oak Forest upon discovery of the removal, went into the city and interviewed the Commissioner of Health for Chicago. That official promptly sent out police officers to try and locate the body with a view of having it buried. The father of the child had in the mean time left the city. Upon his return in a few days Mr. Wright had him arrested and taken before a local Justice of the peace who discharged him. Mr. Cushing then lost another child by diphtheria and upon application to the Chicago Health officers for the necessary burial permit, was also given one for the interment of the body which had been removed from Hinsdale. The Health officers claiming it was necessary to inter as quickly as possible in Oakwoods, the nearest burial ground.

Mr. Cushing then sued Mr. Wright for malicious prosecution claiming \$25,000 damages. The trial occupied the court nearly three days and was ably argued on both sides.

Counsel for plaintiff, maintained that a burial lot once deeded became the private property of the owner, to do as he pleased with. It being competent for such owner to go to that lot either by day or by night, and if desired by the lot owner any body interred upon that lot could be removed by the next of kin without the consent of the cemetery people, quoting many legal decisions in support of his argument; some dating back to 1845. The gist of these cases was that no body could be disinterred without authority; plaintiff contending that the next of kin was the authority.

Defendant's counsel argued that such an inter-

pretation of the law would be monstrous, and that if the court so decided there would be nothing to prevent ignorant persons, particularly foreigners, from digging up at any time the bodies of their relatives that might have died from small-pox or other foul disease, and remove them to any part of the country.

Judge Baker before giving the case to the jury, said that cemetery corporations being sanctioned by the State, were the representatives of the State, and therefore the legal custodians of the dead, and that burial lots were subject to the rules and regulations made for the good government by the cemetery officials.

The learned judge cited many cases both in England and America where the next of kin had claimed the authority to remove bodies and had been decided against the relatives. Authority, his honor said, was not only the next of kin but also the state representatives, the cemetery officials. The latter having no more right to disturb a body without the permission of the next of kin than the next of kin had without the consent of the cemetery officers. In any case of dispute it was easy to apply to the courts for a mandamus. The court instructed the jury to return a verdict of not guilty.

This decision will answer the queries propounded at many of the conventions of the cemetery Superintendents as to rights of removal. *B. L.*

**CARPET BEDDING.**—The style of gardening by which many variegated-leaved plants are arranged so as to represent patterns on carpet is usually much deprecated by those who love the nature in gardening. Certainly the introduction of carpet bedding was a misfortune in this respect, that in many cases it destroyed the taste for individual plants, and many gardens, which, before the introduction of carpet bedding, had a great variety of various flowers blooming the whole season through, were left with nothing but a few strips of floral carpeting. It is well, therefore, that the style has been in a measure shorn of its popularity in private gardens and grounds, for looking the whole season, from spring to fall, at the same piece of carpet, must certainly become monotonous in time. Old fashioned flowers are again assuming their place in private gardens; but, as before noted, there are certain conditions which favor the application of this style,—and this is particularly true of parks and public grounds. To persons who visit these occasionally, the first impression of a first-class piece of carpet gardening is certainly very pleasing. In nearly all our large cities which have great public parks, carpet bedding is among the pleasantest of popular attractions.—*Mechans' Monthly for Feb.*



PARK NOTES.

The estimates of the park commission of Cleveland, Ohio, for the current year amount to \$364,000.

\* \* \*

The West Side park system of Chicago has received for its creation and improvement since the inauguration in 1869, \$6,809,960.12.

\* \* \*

Yonkers N. Y., is to have its first public park, the common council having recently undertaken to secure an eligible tract of some seven and a half acres.

\* \* \*

Buffalo's park commissioners require an appropriation of \$314,000 for park purposes the current year, \$50,000 of which will be devoted to the Botanical Garden.

\* \* \*

The city council of New York have decided to authorize the Park Department to spend \$42,367 in completing the Castle Garden Aquarium. The total amount appropriated for park purposes is \$1,220,255.

\* \* \*

The city solicitor of Philadelphia has given it as his opinion that councils have no power to place on the city plan a square or park in advance of and independent of an ordinance condemning and taking the same for public use.

\* \* \*

Lincoln Park, Chicago, has been presented with a statue of Goethe by the Schwaben Verein. The statue will be a replica of the celebrated work in Berlin, and will probably be cut in American marble and stand on a Vermont granite pedestal.

\* \* \*

The additions made to Rogers Williams park, Providence, R. I., has cost the city \$605, 907.25, which, deducting for buildings, interest, etc., bring the actual cost of the land to 3.9 cents per square foot. The amount of land acquired was close upon 310 acres.

\* \* \*

The announcement that the Louisville and Nashville R. R. Co., will build a park and flower garden at Crab Orchard, Ky., is gratifying. It is a step in the right direction, which would surely result to the benefit of our railroads if it were more liberally followed.

\* \* \*

The annual estimate for the park system of Detroit, Mich., aggregates \$192,000 for this years work. A large amount of paving and roadmaking is included, besides a new Casino, four new bridges and two new toilet pavilions. Some \$8000 will be expended on improvements and additions to the menagerie.

\* \* \*

Over 300,000 acres of land in the Adirondack region were bid in by the state of New York at the recent tax sale, of which it is expected about 150,000 will not be redeemed and will in consequence be added to the Adirondack Park. This is about the proportion usually ruling on tax sales of such property in the state.

\* \* \*

The House committee on Military affairs has decided to recommend the creation of a National Military park on the Vicksburg battle field. The bill contemplates the acquisition of 1200 acres, provides for the appointment of a commission of three to outline the site, and limit the cost of the land to \$50,000. The project is expected to cost half a million. It is in-

tended to restore the fortifications, riflepits, approaches, and parallels of the two armies, to open and restore such roads as may be necessary and to ascertain and mark with historical tablets or otherwise the lines of battle of the troops engaged during the siege and defense within the park or its vicinity.

\* \* \*

Lincoln park, Chicago, owing to the mild weather, for a time, became a public nuisance. The fertilizer abundantly spread upon the lawns gave forth such a decidedly obnoxious odor, and over such a large area, that immediate steps had to be taken to mitigate the evil. It is a lesson that some care must be taken in the choice of fertilizers in our city parks.

\* \* \*

The San Francisco park commissioners have had an elephant on their hands in the electric light tower which formed such an attraction of the Mid-Winter Fair. It was offered to any one who would take it away, but no offers materialized, so it was left to the commissioners to destroy it in the readiest manner possible and realize what they could on the scrap iron.

\* \* \*

Flower shows in our public parks are becoming more popular and rightfully so. A stimulating influence is thus exerted in many directions, besides affording a pleasing and attractive feature in connection with the pleasures to be derived from the parks. In San Francisco this month witnesses the Orchid show, towards the success of which a great deal of spirit has been displayed by the park gardeners

\* \* \*

A new feature in park work in New York city will be the establishment of river parks along the city's water front. This will be done by means of structures erected above the piers of lesser commercial importance. The law embracing these features provides that the Dock Board appoint a competent architect to make designs for these breathing spots. The office of Consulting Architect has been established in this connection.

\* \* \*

Numerous Parisian monuments are surrounded by rails of wrought iron, and these as a rule are gilded over. The quantity of the precious metal utilized is so infinitely small that one can hardly imagine that it would be worth anybody's while to take the trouble to smash and carry away these rails, and yet for several weeks past they have systematically disappeared says *Galignani Messenger*.

\* \* \*

Wyandotte, Mich., is to have a park. The necessity has long been recognized and the mayor of the town has made serious efforts to provide such a beneficial addition to its public features but with little success. By the public spiritedness of a Mrs. Jane Heintzer who has donated a large tract of land, the desired park is now within reach. The amount of the donation will be decided upon what the town may be willing to spend annually on beautifying it, but will range between twenty and one hundred acres.

\* \* \*

National parks seem to be attracting much attention just now. The game commissioner of Maine suggests the establishment of a park of some 200,000 acres in Northern Maine, to include Mount Katahdin, Pamadum, Cook and Millinocket lake, and part of the east and west branches of the Penobscot river. The idea is to create a preserve for the large game and fish which have been so abundant in Maine, whereby a perpetual close time could be assured, and besides a magnificent natural park having all the beauties of nature in her wildest features for the eastern section of the country.



## CEMETERY NOTES.

An eminent German pencil maker, now dead, has over his grave a gigantic stone representation of half a lead pencil as a tombstone, with a core of graphite eight inches in diameter.

\* \* \*

A strange will is that of Anthony P. Shrimmer, one of the oldest residents of Phoenixville, Pa., who was buried recently. Out of an estate of \$35,000, he left \$10,000 in trust to his only child, a daughter, and \$25,000 for a monument over his grave.

\* \* \*

The amendment to the by-laws of the Green Lawn Cemetery Association of Columbus, O., giving the trustees power to grant permission for disposition of bodies in vaults etc., above ground, under prescribed regulations was unanimously adopted at the recent annual meeting.

\* \* \*

A determined effort to bring delinquent lot holders to time is being made in connection with Pine Grove Cemetery, Manchester, N. H. A vote has been passed decreeing that all bodies buried in lots not paid for before May 1st shall be removed to public ground and all right to the lots after that time shall be deemed forfeited.

\* \* \*

"Tom All Alone's" the dismal graveyard in Russell Court, Drury Lane, London, immortalized by Dickens in the Poor Joe episode of "Bleak House," is now almost an "open space," owing to the extensive demolitions in the neighborhood. The old dismal passage and steps have gone, and the yard is paved and laid out as a poor children's gymnasium, but the sullen looking gate with the rust-eaten bars still remains.

\* \* \*

The Iowa health authorities are very strict on the question of transporting corpses of persons dying of infectious diseases. Having discovered that some physicians have either from ignorance or intention, given as cause of death "heart failure," "nervous prostration," etc., the results of said diseases; the authorities have issued circulars justifying railroad men, agents and others in considering death notices marked "heart failure," where age is under thirty, as suspicious and the rejection of the corpse bearing a permit so marked. The circulars contain stringent requirements on the part of all having the care of such cases for transportation.

\* \* \*

The agitation waged in San Francisco against further burial within the city limits has resulted in the passage of an ordinance prohibiting the sale of burial lots within the limits of the city and county. But interments still proceed, due to the determined stand of the cemetery corporators, who claim the ordinance inoperative. All kinds of schemes are being formulated to nullify the law, and it seems to be determined to carry the case to the highest tribunals before giving in, based upon the fact that the cemetery companies have yet considerable land for sale. However, the unsettled condition of things is seriously affecting the cemeteries, the idea of lack of permanency in those in proscribed limits leading purchasers to select lots in more remote places.

\* \* \*

An ancient idea adapted to a modern cemetery is that proposed in the new cemetery of Mount Olivet, San Francisco, which is beautifully situated. While for almost the entire length of the cemetery the slope is both easy and gradual at the extreme southeast a sandstone cliff rises to a great height. It is proposed eventually to level off the face of this cliff, and excavate it for interment purposes in a manner similar to that to be seen in the old world. By running galleries through the material catacombs could be constructed, and with the introduction of

embalming the remains of such people as object to interment, and others to cremation could be disposed of. It is intended to build a crematorium eventually, with the usual columbarium attached.

\* \* \*

Local Improvement Associations are springing up here and there all over the country, a sure sign of the growth of progressive ideas. The higher grade of education, that is education as applied to the development of higher ideas in our schools, is bearing fruit which will produce results in civilization as proper tillage will surely produce crops. These associations are including the local cemetery in their work and we may hope that in a very few years a decided improvement in these neglected spots will be seen.

\* \* \*

A bill has been introduced into the New York legislature to create a new lien law for the better protection of monument dealers. The proposed law provides that: Every person, firm corporation or association that shall hereafter furnish or place in any cemetery or burial ground within this state any monument, gravestone, inclosure or other structure shall have a lien upon such monument, gravestone, inclosure or structure for the principal and interest of agreed price thereof, or such portion of said price as shall remain unpaid until the same be paid in full, provided such person, corporation or association shall at any time, or within one year after the bill for the same becomes due, file a lien with the cemetery officers. If the claim is not paid within six months after the lien is filed the monument or gravestones may be sold at public auction by the person holding the lien.

\* \* \*

The incorporators of the Homewood Cemetery, Pittsburg, Pa., held their annual meeting January 8th. No change made in managers or officers. Exhibits show almost one half million dollars realized from lot sales. Improvements on lots, made by owners of same amount to \$190,000.00, with a permanent improvement fund over \$50,000.00. Among other improvements by the corporation during 1895 mention was made of the completion of lodge house at the Homewood avenue entrance, and a large granite receiving vault. Lot sales 1895 amounted to \$37,000.00, cash receipts \$48,000.00. Mr. David Woods, member of superintendents association, completes his 15th year as Supt. of "Homewood" in April next.

\* \* \*

In the annual report of 1895 of the directors of the Lafayette Cemetery, in the heart of Philadelphia are some interesting notes. Situated as it is, the receiving vault is largely used by the people of the vicinity, to temporarily deposit the remains of deceased until final burial in that or other cemeteries. Besides decorating graves on Memorial Day, the lot-holders are establishing a custom to adorn graves at Christmas time and other seasons. An assessment of 75 cents per lot has been called yearly since 1887, from which all the permanent improvements have been made. The total income for the year was \$3,303.81, which included \$964.25 for burials, vault fees, etc.; \$644.51, assessments. The total expenditures were \$2,976.88.

\* \* \*

Mr. George Van Atta, Supt. Cedar Hill Cemetery, Newark, O., informs us that the ashes of a cremated body were buried in that cemetery on June 9th. 1893. The death occurred at Columbus and the body was sent to Pittsburg for cremation and returned to Cedar Hill. In addition to considerable improvement work, the extension of the water supply has enabled him to construct a fountain. A rock pile was made in the small lake near the entrance and the water supply carried up through it; with a constant supply an effective spray is kept active which is quite attractive. The winter effect of the frozen spray is beautiful.



## Correspondence.

### Removal of Bodies Dying of Contagious Diseases.

FRANKLIN, PA. Jan. 28th 1896.

*Editor Park and Cemetery,*

DEAR SIR:—In your January issue W. R. C. asks for information about removals of bodies dying of contagious diseases. In a letter of Dr. Benjamin Lee, secretary Pennsylvania state board of health, to the baggage agent of the Penna. R. R. Co. who desired information as to transportation of the body of a child dead of diphtheria, buried 11 years, he says: several of the state boards of health, including our own, have within the last two years adopted rules forbidding the transportation of bodies dead of contagious diseases. In reply to a letter from the father of the child, Dr. Lee says: I regret that the rules of our board will not permit the disinterment of and transportation of the body of your child. To the superintendent of the cemetery at Norristown, Pa., he wrote: I learn with much regret that you have been a party to a violation of the regulations of the Health Board of the state and of Norristown, in allowing a body dead of diphtheria to be placed in a vault in your cemetery, instead of being immediately put under the ground. Although your cemetery is outside the limits of the borough, yet it is understood that the regulations in regard to burial apply to all bodies of persons who have died in a borough even though they are to be removed to a distance for burial. The laws of Pennsylvania are very strict in the matter of death from contagious diseases, prohibiting public funerals in such cases and even prescribing a limit to the number of friends attending the private ceremonies. The Board of Health calls for the assistance of ministers of every denomination and order and to incorporate the rules into their statute books. If W. R. C. or any one who desires it, will send me their address, I will try to get circulars from the Board of Health for them.

*C. D. Phipps, Supt.*

Franklin Cemetery,

\* \* \*

RIVERSIDE CEMETERY, FAIRHAVEN, MASS.

*Editor Park and Cemetery,*

DEAR SIR:—It has for some time been my intention to commit to paper my experience and ideas upon the moving of bodies; I always regard that part of my business as second only to the conducting of a funeral as regards decency and decorum. I hope my remarks may not be deemed inappropriate. I have moved bodies in all stages of decay, in the presence of friends and otherwise. If the body has been buried a few months, or anything less than ten years, I calculate to lift the body but little disturbed. In that case I have the new grave open and a new box or coffin, large enough, in readiness; sometimes the casket may be lifted with the grave lines only, using an iron rod with a handle at one end, about four inches at the other end bent at right angles to raise the casket to get the straps under, occasionally I have had to lay boards underneath and beside the casket. It is then raised, placed bodily in the new box, all small pieces of coffin furniture etc. placed with it. Any pieces of wood that are too large are at once carried away and buried. Of course no time is lost in reintering the body. In such cases the remains are never exposed to the view of even a workman. Be sure to have plenty of help as an accident would be simply disastrous. As soon as the casket is uncovered, I sprinkle over it a little chloride of lime as it tends to quell any slight unpleasantness that might arise. If for any cause the casket is exposed to the air for even a few minutes, or if it has to be carried a short distance to a new location we throw over it a piece of sail cloth, not only from motives of decorum, but if a body is exposed for a short

time to the air it will most likely become unpleasant. I always work in rubber gloves, and supply the same to my assistants, always have at hand a pail of water and a piece of soap and when the gloves become soiled wash them while on your hands.

In taking up remains that have been buried for a long period, when the bones are simply collected and placed in a small box they are more or less mingled with mother earth, I always use a mason's trowel to uncover them, searching carefully for all small bones, coffin furniture etc. In all cases should the grave be again opened there would be no trace of previous interment. I have removed bodies that have died from diphtheria and scarlet fever, but none who have died from small-pox, but I would not for a moment hesitate to do it as in my humble opinion, human remains which have been for a few years beneath three or four feet of earth do not retain the same characteristics as they do on or near the surface. While moving a body I once cut my finger deeply with a piece of glass that must have lain on or in a human body for some years and experienced no serious results. I think that if rubber gloves are used and the ordinary rules of cleanliness are observed no evil results are to be feared.

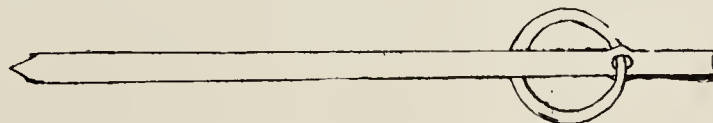
*Thomas White.*

### A Cheap Lot Marker.

Mr. Sid J. Hare, Supt. Forest Hill Cemetery, Kansas City, Mo., sends the following:

When the original stakes in a cemetery, have decayed, or have been carelessly removed it occasions some delay in replacing them before a grave can be laid out, and often in the haste the work is not done with as much care as it should be. The expense of re-staking a cemetery, or the replacing of permanent lot corners of stone or iron is one that few cemetery companies undertake, therefore the work should be done as cheaply, yet as permanently as possible the first time.

As a civil engineer I have studied over this question of permanent corners for the past fifteen years. I have found the stone corners used by the United States for marking section corners



are not reliable, for I know of many that have been shifted; iron bars do not last many years, and are subject to the same danger of being shifted or entirely removed by some unscrupulous surveyor or land owner.

As the result of my experiments in marking corners of lots and blocks, I have found that a hole made in the earth with an iron bar to the depth of from four to ten feet and filled with white sand is as easily found ten years later as would be an iron bar or a stone, and it is almost impossible for any one to remove all traces of it, especially if you fill the hole with a mixture of one-third cement and two-thirds sand. Where rock is encountered a drill will be required to make the hole, and in order to make a contrast in color, I mix red mineral paint powder with the sand and cement; this can readily be seen on the surface of the rock.

I have often thought that if this method were adopted by the U. S. Survey in monumenting sections, it would be a great saving of time and money over the present method of cutting monuments and setting them in place, and if these holes were made to a depth of ten feet, and some color used to distinguish the U. S. Survey corners, there would be less law suits and disputes over their true location.

I find that an iron or steel bar four or five feet in length, and one inch in diameter, made like the figure above, pointed at one end and having a ring set in the other end to give a hold in removing it, is all that is necessary for most work.



### Association of American Cemetery Superintendents.

O. C. SIMONDS, "Graceland,"  
Chicago, President.  
G. W. CREESY, "Harmony Grove,"  
Salem, Mass., Vice-President.  
F. EURICH, Woodlawn, Toledo, O.,  
Secretary and Treasurer.

The Tenth Annual Convention will be held at St. Louis, date to be announced later.

### Publisher's Department.

NOTICE TO SUBSCRIBERS, If this notice is marked with a blue pencil it indicates that your subscription to PARK AND CEMETERY has expired and a renewal of same is solicited.

Park Commissioners and Cemetery trustees are requested to send us copies of their reports.

Photographs and descriptive sketches of interesting features in parks and cemeteries are solicited from our readers.

PARK AND CEMETERY wants the names of every park and cemetery official or employee who would be likely to be interested in this paper. To the many subscribers who have sent in such lists of names, we return our thanks. There are many more that we should hear from.

Subscribers are again reminded that we want brief notes on any feature of park or cemetery work that will be of general interest. PARK AND CEMETERY is the only publication of its class and earnestly solicits the co-operation of subscribers in making it a help to all identified with such work.

### Park and Cemetery PRIZE COMPETITION.

The publisher of PARK AND CEMETERY offers three prizes of TWELVE (12) dollars, EIGHT (8) dollars and FIVE (5) dollars respectively, for the three best papers on the Improvement, Care, and Management of Village and Rural Cemeteries. The papers to be limited to 1500 words.

The papers should discuss: Organization for Management; Methods for Obtaining Funds and Disbursement of same; Annual care and Perpetual care, etc., etc.

The papers will be submitted to a committee of competent cemetery officials.

Papers should be marked with a symbol in place of signature, and under separate Cover, the identification of same should be sent to be used when awards are made.

R. J. HAIGHT, Publisher,

334 Dearborn St.,

CHICAGO.

Mr. Simonds has called our attention to a mistake which we made in our November number in ascribing to him a paragraph which appeared in a report of the Board of Commissioners concerning a system of parks for Essex Co., New Jersey. Mr. Simonds made use of this paragraph in one of his reports, but gave proper credit which we overlooked.

RECEIVED.

From Mr. Geo. Van Atta, Supt., Cedar Hill Cemetery, Newark, O., a fine photograph of fountain in winter.

From Chas. Horton, president, Articles of Association, by-laws and rules and regulations for the government of Woodlawn Cemetery, Winona, Minn.

Earnshaw & Punshon, Landscape Engineers, Cincinnati, O.; Report on a System of Public Parks of the city of Indianapolis, Ind.

Annual report of the Directors of the Lafayette Cemetery, Philadelphia, Pa., for 1895.

Report of the Board of Park Commissioners of the city of Toledo, 1895. The report might well serve as a pattern for such pamphlets. It is comprehensive and beautifully illustrated with half tone cuts and maps, some 27 full page illustrations and several maps helping to compose its 100 pages. The wise expenditure of money in the production of park literature helps more than can be estimated to familiarize the people with various beauties of the parks as well as with their necessities.

TRADE CATALOGUES RECEIVED.

Evergreen Nurseries, Evergreen, Wis. National Plant Co., Dayton, O. Storrs & Harrison Co., Painesville, O. A Blanc & Co., Philadelphia, Pa. John A. Salzer Seed Co., La Crosse, Wis. Pitcher & Manda, Short Hills, N. J. Calendar for 1896 from the Andorra Nurseries, Chestnut Hill, Philadelphia, Pa. Dreer's Garden Calendar, 1896, Henry A. Dreer, Philadelphia, Pa. Wholesale price list,

Old Colony Nurseries, B. M. Watson, Plymouth, Mass.

Water is the greatest necessity in a park or cemetery. It is not a difficult matter to find the supply, but to convey it where required becomes a question of much importance. Dependence has heretofore been placed on the windmill, but you cannot always have the wind. There is a pumping engine specially designed for pumping water that is taking the place of the windmill. It is so simple in construction that a child can manage it. It is absolutely safe, requires no steam and has no valves. All that is necessary is to start a fire. The hot air from the fire starts the engine and keeps it going, and with proper piping water can be sent anywhere—to the house, barn, garden, etc. If any of our readers want to know about this engine they should write for free catalogue to the manufacturers of the De Lamater Rider and De Lamater Ericsson Hot Air Pumping Engines. Address De Lamater Iron Works, 467 West Broadway, New York, N. Y.

**DREER'S**  
RELIABLE  
*Seeds, Plants & Bulbs*

are everywhere known as **the Best**. Why risk poor ones when the best cost no more. Send postage stamp for **Dreer's Garden Calendar for 1896**—richly illustrated; two colored plates on cover, of popular flowers. It describes everything **New and Old, of Merit.**

**HENRY A. DREER,**  
714 Chestnut St., Philadelphia.

**FENCING**

For **HOGS, POULTRY,**  
and all fence purposes.



Galvanized before Wending.

Standard Fencing of U.S.

Thousands of Miles in Use.

Always gives satisfaction. Sold by dealers. Freight paid. Take no other. Catalogue free.

**McMULLEN WOVEN WIRE FENCE CO., CHICAGO, ILL.**

### WATER LILIES.

We have added Aquatics to our line of specialties and carry a full line of stock suitable for all purposes. Victoria regia (new type unsurpassed) Nymphæas, hardy and tender, all colors, Nelumbiums (Egyptian Lotus) in variety, hardy ornamental grasses, Bamboos, perennials and sub-aquatic plants. This department is under the management of the well known specialist, William Tricker who has merged his stock into ours. Dreer's Garden Calendar for 1896 mailed for a stamp describes everything in Seeds, Plants and Bulbs,

714 CHESTNUT ST., HENRY A. DREER, PHILADELPHIA.

### Standard Flower Pots.

Where Flower Pots are to be had in constant use and never sold as is the case in all Cemeteries the best that can be procured are the cheapest. For many years past, **A. H. HEWS & CO.**, of North Cambridge, Mass., have furnished all the leading Cemeteries of Massachusetts, and by permission would refer to **MR. JOHN G. BARKER**, Supt. of Forest Hills Cemetery, Boston, Mass., or **Mr. Henry Ross**, Supt., Newton, Mass., Cemetery. Illustrated catalogue sent free on application.











PARK AND CEMETERY  
VOLUME VI.



March, 1896—February, 1897.



R. J. HAIGHT, PUBLISHER.

CHICAGO.







# INDEX.

**A**

Acceptable Grouping of Mixed Shrubs..... 334  
 Address of President Simonds at St. Louis Convention of A. A. C. S. 324  
 Advertising by Flower Beds..... 318  
 Agricultural Education in Russia. 373  
 Arbor Day..... 251  
 Arches, Tombs, etc., of China, The, 270  
 Architecture and Landscape Work, The Harmony of..... 342  
 Army Worm, Exterminator for... 352  
 Association of American Cemetery Superintendents.....270, 305, 309, 324, 329, 348.  
 Autumn Landscape Effects..... 341

**B**

Botanical Gardens..... 247, 373  
 Botany in the Public Schools..... 415  
 \*Brick Roadways..... 407  
 Bronx Park Botanical Garden, New York..... 393, 411  
 Burial by Cementation..... 266  
 Burial Customs, Ancient..... 288  
 Burial Places of the Apostles..... 357  
 Busy Months of the Year..... 251  
 Burial in Japan, Cost of..... 320

**C**

\*California University Gardens, The Cemetery and the Local Press, The. 359  
 Cemetery as an Educator, The.... 229  
 Cemetery as a Work of Art, The,—Paper by Mrs. Fanny Copley Seavey... 344  
 Cemetery Monuments, An Argument Against..... 412  
 Cemetery Progress, Leading Spirits in..... 306  
 Cemetery Should Be! What a Modern—Paper by Wm. Stone. 327

**Cemeteries:—**  
 \*Bellefontaine, St. Louis..... 325  
 \*Calvary, St. Louis..... 325  
 \*Cave Hill, Louisville..... 380, 409  
 \*Crown Hill, Indianapolis, Ind... 238  
 \*Custer Battle Field, The..... 254  
 \*Forest Hill, Kansas City..... 315  
 \*Franklin, Franklin, Pa..... 276  
 \*Homewood, Pittsburgh, Pa.... 292  
 Hunnish Cemetery at Cziko.... 299  
 \*Lexington Cemetery, Lexington, Ky..... 360  
 \*National Cemetery, Chattanooga, Tenn., The..... 388  
 Pine Hill, Dover, N. H..... 338  
 \*Prospect Hill, Norfolk, Neb.... 270  
 \*Riverside, Norristown, Pa..... 400  
 St. John's Cemetery, N. Y. 320, 394  
 Turkish Cemeteries..... 231, 313  
 \*Woodlawn, New York..... 220, 308  
 Notes..... 231, 248, 266, 284, 302, 320, 338 354, 374, 394, 412, 430  
 \*Chapel, Conservatory and Receiving Vault, Rose Hill Cemetery, Chicago..... 422

Chinese Burial Plot, Brooklyn, N. Y..... 266  
 \*Church, Bonchurch, Isle of Wight, England, The Old..... 402  
 Clergy and the Cemetery, The.... 397  
 Clergymen Aiding in Modernizing Cemeteries..... 409

**Correspondence:—**  
 Association of American Cemetery Superintendents..... 321  
 Botanic Gardens..... 413  
 Drainage..... 264  
 Location of Graves in Lot..... 264  
 Photos of Fine Specimens Wanted..... 413  
 Spring Work..... 413  
 Sunday Funerals..... 303, 321  
 Work at Pine Grove Cemetery, Lynn, Mass..... 285  
 Cremation..... 395

**D**

Death, A More Rational View of,—Paper by Prof. J. B. Johnson... 367

**E**

Economy v. Balance Sheet..... 415  
 Elk Horn Fence..... 411  
 \*English House in Philadelphia, An Epitaphs..... 279  
 Essential Features of the Park,—Extracts from Paper by O. C. Simonds..... 260  
 Essex County, N. J., Park System..... 355, 411

**F**

Fall Work in Cemeteries..... 356  
 Fertilizers, Chemical..... 365  
 Flowers at the Missouri Botanical Garden, St. Louis..... 312  
 Flowers, Origin of Some..... 365  
 Flowers, Revival of the Use of.... 246  
 Flower Show, Chicago, The Annual. 370  
 Forest Area of Europe..... 317  
 Forestry Commission of New Hampshire..... 265  
 Forestry in our Agricultural Colleges..... 265  
 Frost Pictures of the Alps, The... 306  
 Funeral Reform..... 302, 379  
 Funerals, Sunday..... 430

**G**

Garden Experiments in Southern California..... 278  
 Gardens of Babylon, The Hanging. 399  
 Gardens of Buckingham Palace, London..... 355  
 \*Garden Plants.—Their Geography:—  
 Celastrus, Rhamnus and Cissus Alliance..... 364  
 Dianthus, Portulacca and Tamarix Alliance.... 240, 262  
 Genista, Rosa and Drosera Alliance..... 405, 424  
 Geranium, Citrus and Cedrela Alliance..... 314, 332

Hypericum, Gordonia and Dip-terocarpus Alliance..... 274  
 Malva, Hibiscus and Tilia Alliance..... 1294  
 Olax, Ilex and Cliftonia Alliance..... 350  
 Sapindus, Æsculus and Rhus Alliance..... 386  
 \*Pittisporum, Polygala and Vochysia Alliance..... 224  
 Gardening, Twentieth Century... 384  
 Glass Bricks in Horticultural Buildings..... 409

**H**

Horticultural Society,—St. Johns, N. B..... 321  
 Hybrid Species,—Principles and Laws of Interbreeding of Plant Life..... 401

**K**

\*Kantz Vault, New Orleans, The... 354  
 Keep off the Grass..... 323  
 Kentucky Notes..... 402

**L**

Landscape Gardening, Evolution of 359  
**Legal Decisions:—**  
 Accounting of Cemetery Company..... 282  
 Board of Health to say about Cemeteries..... 318  
 Bound to Pay for Coping..... 281  
 Exchange Sustained..... 410  
 Exempting Cemeteries from Public Burden..... 228  
 Grounds for Appointment of Receiver..... 318  
 Liability for Illegal Disinterment..... 281  
 Libellous Inscriptions on Monument..... 353  
 Lien Law, New York..... 430  
 Limit to Notice Given by Grave. 263  
 Monument Lien Law Held Unconstitutional, (N. Y.)..... 339  
 Right of Access to Cemetery Lot..... 377  
 Rights in Burial Places..... 263  
 Rural Cemeteries May Acquire Land..... 228  
 Taxing Lots..... 413  
 Title by Adverse Possession... 300  
 Unsightly Cemetery Lot not a Nuisance..... 357  
 Validity of Ordinance Prohibiting Sale of Cemetery Lots... 410  
 Landscape Gardening in China.... 353  
 Luminous Plants..... 369

**M**

Memorial Day, Confederate..... 242  
 Memorial Fountain, Jamestown, N. Y..... 245  
 Memorials, Useful..... 233  
 Microbes in Graves..... 413  
 Monuments, Some Peculiar..... 352



**Monuments:—**

\*Benjamin Franklin, Chicago... 290  
 \*Booth Memorial, Woodlawn Cemetery, New York..... 343  
 Burns, A Memorial to..... 289  
 \*French Memorial by Mercie, A: 257  
 \*Garfield, James A., Philadelphia..... 290, 310  
 \*Gilbert, Thos. D., Memorial Bust, Grand Rapids, Mich.... 335  
 \*Grant Monument, New York, The ..... 278  
 \*Harrison, William Henry, Cincinnati..... 290  
 \*Mausoleum, Milwaukee, The, Blatz..... 426  
 \*Orsell Cook Monument, The Jamestown, N. Y..... 298  
 \*St. Winifred Fountain, Hudson, N. Y., The..... 385  
 \*Uri Balcom, Chicago, The.... 408  
 \*Washington Monument, Philadelphia, The..... 272

**N**

National Park in Wyoming..... 265  
 Natural Mausoleum, A..... 285  
 Natural Monument, St. Luis, Obispo, Calif..... 300  
 Nebraska State Cemetery Association..... 357  
 Necessity of Comparative Arbitrariness in Cemetery Rules..... 305  
 Necropolis, The London..... 374  
 Niagara Falls, State Reservation.. 230  
 Notes from the Dog-Eared Book of a Traveler and Observer..... 420  
 Nurseries for Parks and Cemeteries 270

**O**

Ornamental Bedding for Small Cemeteries..... 226  
 Ornamental Planting for Parks and Public Grounds..... 227, 252  
 \*Osborne, The Marine Residence of Queen Victoria..... 311

**P**

Paris in 1900..... 319  
 Park and Cemetery Literature in Public Libraries..... 379  
 Park Flower Shows..... 373  
 Park Land in Many Cities, Number and Acreage of..... 283  
 Park Making as a National Art.... 397  
 Park, Newport, N. H., Blue Mountain..... 301

**Parks:—**

\*Belle Isle Park, Detroit..... 330  
 \*Chattanooga-Chickamauga, National Military Park..... 416  
 Lake Front Park, Chicago..... 429  
 \*Lincoln Park, Chicago, Enlargement of..... 307  
 \*Lincoln Park, Chicago, Some Monuments in..... 347  
 \*Milwaukee, Wis., Park System, The..... 316

\*Minneapolis, Minn..... 235  
 Notes..... 230, 247, 265, 283, 301, 319, 337, 353, 373, 393, 411, 429  
 South-Park, Quincy, Ill..... 366  
 \*Riverside, Toledo, O ..... 218  
 \*Park Place, Henley-on-Thames, England..... 336  
 Park, St. Lawrence International 230, 355  
 Parks and the Poorer Classes, The: 323  
 Parks,—Extracts from a Paper by J. F. Foster..... 398  
 Parks in Chicago..... 287, 337

**Perpetual Care:—**

Allegheny Cemetery, Allegheny Pa..... 303  
 Amount to be Funded ..... 266  
 Bohemian National Cemetery, Chicago..... 412  
 Fairmount Cemetery, Buffalo, N. Y..... 284  
 Flushing Cemetery, Flushing, L. I., N. Y..... 248, 303  
 Fund of Greenwood Cemetery, Brooklyn, N. Y..... 248  
 Lakewood Cemetery, Lake City, Minn..... 5  
 Magnolia Cemetery, Charleston, S. C..... 266, 302  
 Mankato, Minn..... 320  
 Mount Auburn, Boston ..... 431  
 Mountain View Cemetery, Oakland, Cal..... 4  
 Muncy Cemetery, Muncy, Pa.. 302  
 Oak Grove Cemetery, Delaware, O ..... 374  
 Oakland Cemetery, St. Paul, Minn..... 412  
 St. Johns, N. B., Rural Cemetery..... 303  
 Photographing Cemetery Monuments..... 415

**Plants,—**

Australian Lily, The..... 333  
 Cannas. Care of in Winter.... 365  
 Golden Rods and Asters..... 351  
 Hardy Woody Vines in Landscaping..... 391  
 Pemperion, Fecundity of..... 352  
 Phlox, Sweet Scented..... 365  
 Rosebush, The Oldest Known.. 317  
 \*Ros s, Hybrid Wichuriana..... 419  
 \*Spiraea Tomentosa Alba..... 357  
 Yew Trees, The Oldest Known. 318  
 \*Yuccas at Lincoln Park, Chicago 273  
 Politics in Public Parks..... 318  
 Public Parks of St. Louis..... 337  
 Public Reservations..... 265  
 Publisher's Department, 232, 249, 267, 286, 304, 322, 340, 358, 378, 396, 414 432

**R**

\*Receiving Vault, Prospect Hill Cemetery, Omaha, Neb..... 348  
 Roads, The Roman..... 271  
 \*Rockerries at Pine Grove Cemetery, Lynn, Mass..... 371  
 Rules and Regulations..... 282, 357  
 Ruskin on Vegetation..... 297

**S**

Shelter Houses..... 287  
 Sidewalk Trees..... 217, 230  
 Smallest Burial Ground in the World... 338  
 Small Parks of Philadelphia..... 303  
 Spider of Italy, The Tomb ..... 367  
 Spraying Trees..... 337  
 Spring Works..... 217  
 State Cemetery Associations..... 341  
 Statutes of Ohio Relating to Formation of Cemetery Associations.. 234  
 Story of the Garden ..... 349  
 Strauch, Adolph, Memorial..... 256  
**Suggestions for Cemetery Officials.**  
 Cleaning Tombstones..... 245  
 Educating Lot Owners..... 245  
 Lot Enclosures, Paths, Etc..... 287  
 Uniforms and Tents..... 240

**T**

Tavern in a Churchyard..... 356  
 Three Most Beautiful, Hardy, Deciduous Shrubs..... 345  
 Tree Planting in Chattanooga, Tenn..... 301  
 Tree Planting in New York City.. 411  
 Trees..... 329  
 Trees and Plants in Parks and Cemeteries, Labelling..... 252  
 Trees and Shrubs in Jackson Park, Chicago..... 288  
 Trees and Shrubs, Spring Flowering 258  
 Trees Interfering with Roads. .... 398  
 Trees in Our Parks..... 319  
 Trees, The Age of ..... 247

**Trees.**

Black Jack Oak, Dwarf..... 392  
 Dragon Tree of Oratava, The.. 401  
 \*Evergreen Magnolia, The.... 427  
 Fireproof Tree, A ..... 347  
 \*Golden Leaved Scotch Pine, The 280  
 Milk Tree, The..... 425  
 Oak, The English..... 261  
 \*Oak, The Lucombe..... 226  
 \*Palms, Number of..... 352  
 \*Pines in Fairmount Park, Philadelphia ..... 243  
 Trees, Food Bearing..... 372, 392  
 Whistling Tree, The..... 337  
 Trust Funds, Rules for Receiving..... 264, 282  
 Tulips for Decoration Day..... 394

**V**

\*Village Adornment..... 300  
 \*Village Improvement: 233, 301, 338, 371

**W**

**Water Gardens.**

Lily Garden..... 393  
 Nelumbium Album Grandiflorum..... 427  
 The Lily Pond ..... 277  
 \*Tower Grove Park, St. Louis, Mo..... 222  
 Water Lilies..... 299, 404  
 Water Plants as Landmakers..... 404  
 Weeds, To Get Rid of..... 264



# PARK AND CEMETERY.

FORMERLY THE MODERN CEMETERY.

A Monthly Journal Devoted to Parks and Cemeteries.

R. J. HAIGHT, Publisher,  
334 Dearborn Street, CHICAGO.

Subscription \$1.00 a Year in Advance. Foreign Subscription \$1.52

VOL. VI. CHICAGO, MARCH, 1896. NO. I.

## CONTENTS.

EDITORIAL.....	217
*THE PARKS OF TOLEDO, O.....	218
*WOODLAWN CEMETERY, NEW YORK CITY.....	220
*A CHARMING WATER GARDEN.....	222
*GARDEN PLANTS—THEIR GEOGRAPHY, V.....	224
ORNAMENTAL BEDDING FOR SMALL CEMETERIES.....	226
*THE LUCOMBE OAK.....	226
ORNAMENTAL PLANTING FOR PARKS AND PUBLIC GROUNDS.....	227
LEGAL.....	228
CORRESPONDENCE.....	229
PARK NOTES.....	230
CEMETERY NOTES.....	231
PUBLISHERS DEPARTMENT.....	232

\*Illustrated.

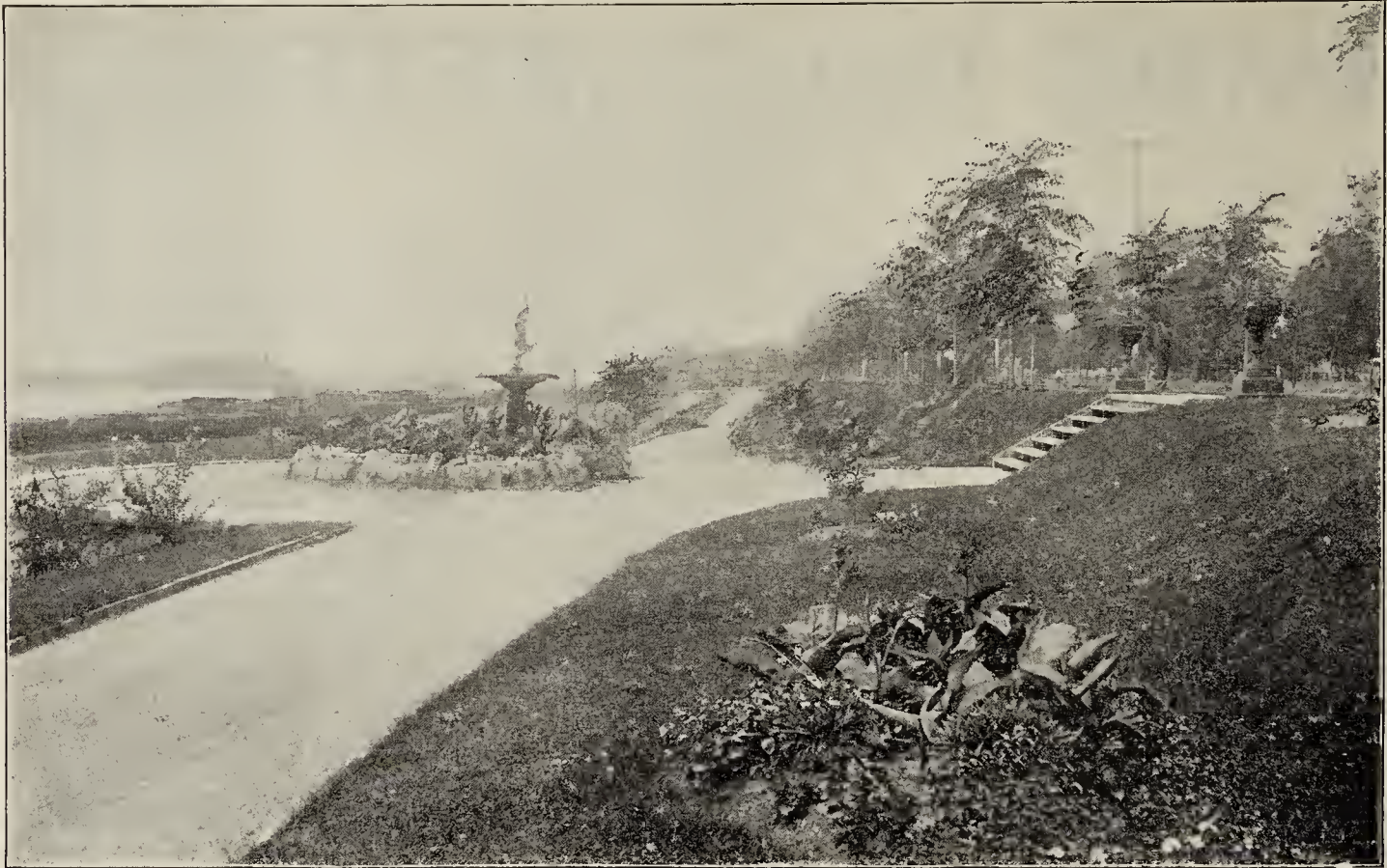
MUCH attention has been drawn to the neglected conditions of our rural and village cemeteries, which in some measure is undoubtedly due to the lack of knowledge of how to proceed in a systematic manner to care for them. To obtain the best information in this direction competitive papers on the subject are invited, in accordance with directions which will be found on another page of this issue. It is a problem, the solution of which will be of lasting benefit to the community.

THE boisterous month of March, with its sunshine and shadow, rain, sleet, and rampant changefulness, is nevertheless the month in which the superintendent rouses from the monotony of his winter's duties and sets himself in the full tide of mental activity for the spring flood of park and cemetery work. The months of comparative inaction so far as outdoor labor is concerned, should have developed schemes of improvement and fostered rearrangements of detail, which create impatience for opportunity of carrying them out and testing their values; and the present month lends itself to the maturing of plans which the coming weeks will sooner or later afford occasion for putting into effect. The short springtime in our northern latitudes makes it necessary that not only should everything be in readiness to take advantage of the first settled

weather for outside work, but that it may be carried to completion with as much dispatch as possible. Hence the prime advantage of having so matured the scheme of spring operations that an adequate force of help should be engaged to carry it out beyond a question of delay. With our cemeteries, Decoration Day has a certain limiting time mark, when the grounds should be as clean and attractive as possible, which is a pointed argument in favor of a sharp spring campaign. Moreover, notwithstanding, the more or less damaging effects on the cemetery grounds of the crowding visitors, it is unquestionably to the advantage of the cemetery associations that their properties should be in a holiday dress of beauty, full of charm and attractiveness, so as to impress a sentiment as forceful in its influence on the living as that which impels the offerings of flowers at the resting places of the dead.

THE Park Commissioners of Louisville, Ky., have again addressed the citizens of that city on the subject of sidewalk trees, and their example might be profitably followed in many other places. In the matter of trimming large trees the average property owner knows little, if anything, about it, as may be observed anywhere and everywhere where sidewalks trees are abundant. As a matter of fact this kind of pruning requires expert knowledge, and the different appearance of sidewalk and park trees substantiate the statement. Really, a very small percentage of the larger trees require any cutting, whatever, where the conditions serve their characteristic nature, and the indiscriminate lopping off here and cutting back there, which is the general practice, means little else than destruction, if not of the life of the tree, at least of its natural beauty. Besides the injury done by injudicious trimming, untold damage results in the spring from the hitching of horses in their proximity, whose propensity for nibbling at the barks is a constant menace to the health of trees. Where such an evil may be expected, some protection should be provided; and in fact no effort should be spared to give our city trees every chance to display their beauty, for in this not only is their usefulness for shade purposes improved, but the attractiveness of the thoroughfare becomes a permanent investment and stamps it as a business proposition.





RIVERSIDE PARK, TOLEDO, O.—FERRACE VIEW TO THE SOUTH.

#### The Parks of Toledo, O.

Considering the short time during which any organized system of park work has been in operation in Toledo, O., that city is to be congratulated on the progress so far made towards the acquisition of a system of public parks, adequate to the needs of a city of its size and importance, local conditions, and over 81,000 inhabitants.

Active operations have only been in force for a little over three years, or since the season of 1891-'2, when the Board of Park Commissioners took charge. The total park area so far acquired amounts to 698 acres, to which must be added numerous triangular spots in various parts of the city. The first care of the Commissioners after purchasing the properties was to secure in sufficient quantities trees and shrubs for their improvement, which were planted out in the nursery and cared for until actually required, and the result of which has been beneficial. While it has been impossible, in the short lapse of time, to create permanent effects, a surprising progress is to be noted, nearly all the new property has been underbrushed and prepared for immediate work, besides being available for public use to a considerable extent.

The total cost of the acreage and improvements up to January 1, 1896, amounts to \$825,570, but at present untoward financial conditions are temporarily suspending all park work. It may be added

that the work of the Commissioners has not been accomplished without severe criticism, a condition which generally attaches to such public functions, where the conservative policy may be expressed by the idea: "We want the parks but do not want to pay for them." This grade of conservatism loses its regulating force when directed against a properly devised park system, because the universal experience is that parks are not only beneficial from the moral and sanitary standpoints, but their establishment at once increases the value of neighboring properties in a very pronounced and profitable way.

The plan pursued in the work of improvement and which has been carried out in the three years of actual operations, has been to open and clean out the properties, and shape and grade the ground to such an extent as to permit of the planting of shade trees and shrubbery at the earliest possible time.

Toledo has a large amount of water frontage, which has had considerable influence in determining purchases, and Riverside Park, a view of which is given, has been transformed from a ragged unsightly strip of river land into a floral terrace, with good driveways and paths, making it the promenade and driving ground of the lower part of the city. It contains some 33 acres.

City Park, an area of seven acres, possessed of a beautiful forest growth of fine trees, so thinned out as to allow of a flourishing lawn, and embellished



by a miniature lake with fountain, surrounded by a liberal array of foliage plants and flowers, is a favorite resort.

Walbridge Park, a delightfully refreshing view in which is given, comprising 65 acres, is situated on the river bank on the edge of the city, and possesses exquisite river scenery. Considerable work has been done on it in grading, road-making, seeding and planting, and considerable development of its many picturesque features are in initial progress. Three bridges span its deep ravines.

Ottawa Park, a tract of 280 acres, the largest park of the city, is an area of magnificent possibilities in the way of landscape art, being well supplied with water, the Ottawa River meandering through a large section of it. It is destined to be the driving park of the west end of the city, and a large amount of work has already been done in grading and road-making, and two substantial iron bridges constructed over the river. Some 20,000 trees and shrubs have been planted out, and as the soil is admirably adapted to tree growth, it may be assumed that a very few years will bring gratifying results.

Guyon Park, of 150 acres, situated on the shore of the bay on the outskirts of the city, except for cleaning out, is still in a state of nature, but will afford opportunities for excellent landscape work, when the time arrives that funds are available.

Such are the principal park properties of Toledo upon which work has been done, outside the small plats in the city proper, which are made flower gardens for brightness, and it can be imagined that with the lake and river advantages of the city, her opportunities for variety and beauty in park landscape work cannot be excelled. In the report of Mr. M. G. Kern, the Landscape Gardener and Superintendent of the system, he reprints a paper on "Parks and Their Uses," by the late Hon. William Baker of Toledo, that the author summed up as follows:

"1. That a suitable and attractive system of parks and boulevards is of great and unmeasurable advantage to any city, in the promotion of the health, happiness, culture and well being of its citizens, and in its attractive power to draw to itself constant accessions of cultivated and agreeable people from abroad.

"2. That instead of being a mere luxury, which an overtaxed people cannot afford, it is a luxury, greater even to the poor than to the rich, and is the cheapest luxury a city can enjoy, because the thing itself creates the wealth from which its cost is paid.

"3. That from the length of time required to develop and mature it, especially in the growth of trees and shrubbery, no time ought to be lost in commencing it, even if afterwards its progress should be slow and cautious.

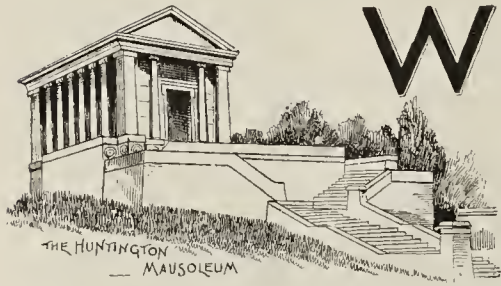


WALBRIDGE PARK, TOLEDO, O.—RAMBLE ON THE NORTH SIDE.



# PARK AND CEMETERY.

## Woodlawn Cemetery, New York City.



**W**oodlawn Cemetery is one of the well known cemeteries of the country, not alone from its being a pioneer in

the "lawn plan" of cemetery design and its other varied landscape attractions, but by the large number of fine mausoleums and monuments it contains and the wealth of the families owning property therein. It is situated on the lines of the N. Y. & H. and the N. Y., N. H. & H. railroads, twelve miles from the Grand Central Station, New York City. It was organized in 1863 and improvements commenced in 1864; the first interment taking place on January 14, 1865. In area it covers some 400 acres, the arrangement of which is shown on the accompanying plan. The greatest elevation is about 200 feet above sea level and the land comprises loam, gravel,

clay and rock in its formation. The two lakes have an area of three and a half acres.

Forty sections of an average area of four acres are laid out, and there are nine and a quarter miles of Telford macadam road traversing the cemetery. Many of the lots are of large area, from forty thousand and down to five thousand square feet.

Two sections are devoted to single graves, containing about six acres, the head stones on which must not exceed two feet in height.

The lawn plan is the ruling principle and there are no visible paths except around circular plats. While no restrictions are placed about mounding graves it is recommended not to exceed four inches.

It is not required that designs be submitted before erecting monuments, but the comptroller exercises his judgment on mausoleums, which must be constructed of permanent material—granite, marble, good stone and real bronze.

There are two receiving vaults, the old one containing 150 catacombs, and the new one built a few years ago, at a cost of \$12,000, with 138 catacombs. Altogether there have been 47,613 interments since



MAP OF WOODLAWN CEMETERY, NEW YORK CITY.



its opening, the yearly average for the past six years being 2,155.

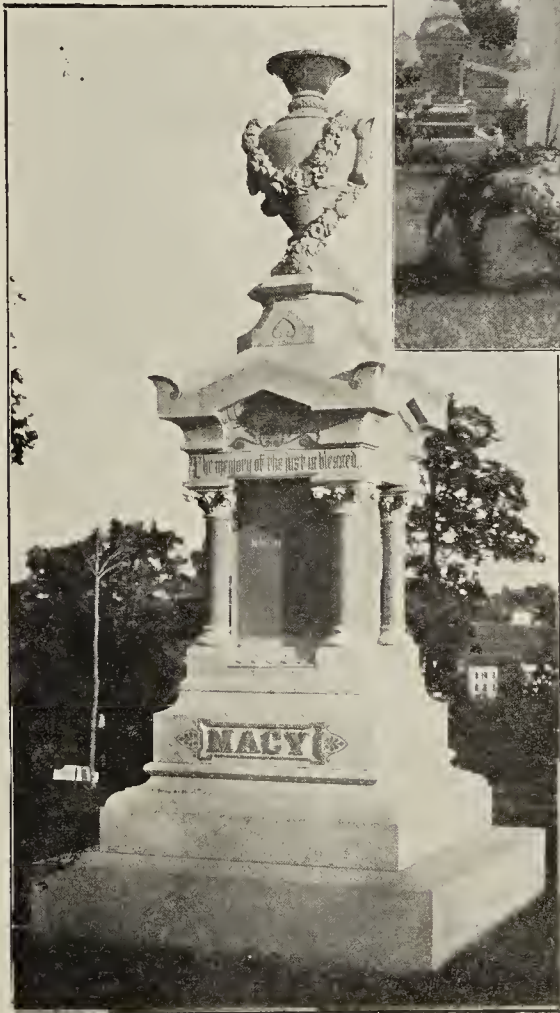
The original surveyor of Woodlawn was James Sidney, long since dead, and the present superintendent is Mr. H. J. Diering, whose name has frequently appeared in these columns.

The map gives the general lay-out of the cemetery with sufficient clearness to display the salient features of the design. Although organized thirty years ago, when it was customary to enclose lots either with stone curbing, iron railings or natural hedges. Woodlawn is to-day conspicuous for the absence of such relics of bygone practice, the officials of the cemetery having persuaded the lot owners to allow of their removal, and now very few remain, giving great satisfaction.

The rules and regulations are comprehensive and carefully enforced; the grounds are policed by uniformed employees, and attendants and grave diggers are also recognized by an appropriate uniform,

which imparts a dignity and order to the occasion.

The striking features about Woodlawn are undoubtedly its tombs and monuments, and in costly mausoleums it is perhaps unrivalled. The initial cut of this article is a sketch of the C. P. Huntington mausoleum, which is said to have cost some



\$250,000, and to be the most costly in the world. The tomb proper is twenty-eight by forty-two feet with roof twenty-four feet above the platform. It is built of granite of fine quality, the stone also being of unusual size.

The Morisini mausoleum, which has been illustrated and described in these columns in a previous issue, is of striking design.

One of the most imposing examples of mortuary architecture in the country is the beautiful temple-like structure erected some years ago for the late Jay Gould. It is always considered to resemble the Parthenon, Athens, but it is more like the temple of Theseus, the architect avers. It is Ionic in style and many authorities claim it to be the best specimen of pure Grecian architecture in the United States. In area it is thirty-three by twenty-two feet, the roof being twenty-two feet above the ground. There is no mark whatever on the exterior of this structure to identify it.

Besides the Warner, Foster and Dunlop tombs, there are many other costly mausoleums on the grounds, besides a large number of fine monuments of varied design and material. The illustrations on this page explain themselves. A very large amount of money is annually expended on memorial monumental work in Woodlawn Cemetery.



### A Charming Water Garden.

The most attractive lily pond that I know is the one for hardy aquatics at Lincoln Park, Chicago: and the prettiest water garden I have ever seen was the one in Tower Grove Park, St. Louis, in the summer of 1895. Water garden is the right name, for it consisted of a chain of pools, irregular in size and shape, connected by narrow, winding channels. The water was shallow, but as the surface of a good part of the system was sunk three feet below the level of the surrounding lawns, the effect of the sloping banks gave variety and added greatly to the appearance of the design.

The art of the designer of this delightful water garden was seen in the graceful plan of pools and



TYPICAL VIEW IN THE WATER GARDEN.

tortuous channels with their setting of emerald banks; in the adaptation of plants to the position best fitted to display them to advantage and to develop the characteristic growth of each; but perhaps most of all in the nice blending of the water scene with its surroundings. This was done by the fitting use of semi-aquatics, as well as of plants used in the groups and beds on the lawns near the water. One could scarcely determine where water plants ended and bedding began, so artfully were the two wedded by the choice of plants and by their distribution to soften or disguise boundaries.

An excellent example of the application of the latter general rule in Landscape Art is seen in our illustration of the Lotus Bed. Looked at from either

the water or the land side, the circular clump of Lotuses either ends or begins the view—one feels that beyond it there may be more water garden or there may be more lawn. There is that pleasantly mysterious uncertainty as to what lies beyond that is the essence of Landscape Art.

In most locations a duplicate of the Tower Grove Park aquatic garden would involve great labor and expense too, perhaps, but its making was simplified by the peculiar character of the soil in that part of the park. As the sub-soil is fire clay the loam above is always more or less spongy with moisture, and by merely excavating the series of basins and channels, the water is held as in a dish. There is always water, but the pools are, neverthe-

less, supplied with the overflow from a large natural pond on a trifle higher level so there is a slight movement throughout the system to an outlet at the lowest point where the surplus escapes. This creates a gentle ripple that gives life to the surface and makes agreeable conditions for the plants as well as for the lively gold fish that find this flowery water way a summer resort quite to their liking.

The larger aquatics inhabit the pools, the largest, forty-five feet in diameter, being reserved for Her Majesty *Victoria regia*. To insure the high temperature demanded by this royal plant there is a cemented basin in the centre of the pool, which contains the heating pipes and boxes of roots. This basin is enclosed in a rim of masonry the top of which is slightly lower (perhaps six inches) than the level that is maintained in the pool during the warmer months, so that when the weather permits the water is raised until the masonry of the basin is submerged—an excellent feature that takes away artificiality and makes the Queen look less exclusive and quite Americanized. All of the *Nymphaeas* were used as well as the highly ornamental *Euryale Ferox* or Gorgon plant. The winding channels were irregular in width and in the wider spaces small *Nymphaeas*, as the starry little Japanese *N. Pygmaea*, and *N. Ledegkeri rosea* with flowers that sit on the water like birds, apparently quite detached from any plant.

The grouping of water Poppies, two kinds of water Hyacinths viz: *Eichornia crassipes* and *E. Cerulœa*,



three varieties of *Limnanthemum* including the exquisite little water daisy, *Cyperus alternifolius*, variegated *Scripus*, the vivid green velvety rosettes of *Pistia Stratioides*, *Salvinia natans* with dainty miniature foliage, and the tiny water fern *Azolia Caroliniana*, was perfect. Each species and variety found a home to its liking in the various conditions of depths and shallows, shade and sunlight, open and sheltered places afforded. And from among the interstices of rocks grouped at intervals on the banks, plummy sprays of Parrot feather, (*Myriophyllum*), was allowed to mingle at will among the other plants, being, however, held in check by judicious pruning. The fairy-like blossoms of the water daisy were for the first time seen in a setting that did not dwarf them. A thick hedge of water hyacinths outlined one side of a crescent shaped pool and in other places bordered narrow inlets or grew like luxuriant floating islands on the water, seeming to grow and flower with the same abandon as in the canals and bayous of New Orleans where it has become naturalized and threatens to drive out, not only native growths, but navigation as well. Forget-me-not flourished amazingly in the fullest sunshine where its roots were entirely submerged, and in the swampy margins of the water way beds of double white *Sagittaria Japonica*, the more common *S. Montividensis* and groups of *Acorus variegata* did splendidly and gave pleasing variety. And at intervals near the water grew clumps of *Eulalia gracillima*; *Colocasia esculenta*, and *C. odorata* or Tara plant with immense leaves and edible stems, both members of the *Caladium* family; *Cannas* faced with *Pennisetum longistylum*; the great reed *Arundo Donax*; the extremely decorative *Papyrus antiquorum* or true Egyptian paper plant; and several species of bamboo, viz: *Bambusa arundiana*, *B. Metake*, *B. Nana*, *B. Argentea*, *B. Aurea*, *B. Vulgaris*, *B. Tortiense* and *Arundiana falcata*. The Reed, *Papyrus* and *Bamboos* were grown in rather swampy soil, did well and were ornamental the season through. They fitted the position, too, by harmonizing with their surroundings in habit and foliage. Indeed the *raison d'etre* for this paper lies in calling attention to the combination of plants used in the water garden and its vicinity to the end of having others follow suit, because the result was so harmonious and altogether good.

Several plants that would have been especially at home in the swampy land near the water were missing, probably because their best effect is fleeting compared with most of those used. Some of them however are so desirable for a time that they are worthy of a place in such designs, the more so that they are not unsightly even when their best stage is past, and when they are, the planting can

be so arranged that they can be cut off and their places taken or covered over by adjoining plantings. Those to be most highly recommended are Irises in variety but particularly the exquisite Japan Irises that would be in their natural environment in such localities. And nothing could be finer than single specimens or groups of the hardy and very handsome *Heracleum giganteum* or Giant Parsnip.

This really stately plant is, I think, not much used in the West but in the East it is given the place it richly deserves as an ornamental plant of great worth. It is perfectly hardy in swampy soil



A BIT OF THE VICTORIA POOL.

around Chicago, where it grows wild in at least one locality and makes, in early summer, a show worth going to see. It grows in moist land, attains a height of nine or ten feet, and each stalk bears numerous enormous corymbs of pure white flowers of the familiar Parsnip type and very attractive. The foliage is large, deeply cut and effective and the entire plant semi-tropical in appearance. The great stalks must be cut off after flowering as they become unsightly if allowed to stand.

Referring to our illustrations: The Lotus bed shows plants only one year old that were placed in the pool in June after their growth was well established—this is considered by Mr. James Gurney, Supt. of the park, essential to their successful





LOTUS BED.

growth, and he is firm in the opinion that disregard of this rule is the cause of frequent failures with the stately Egyptian Lotus. As the *Nelumbium* is hardy it is left in position after once established, but this was a new bed. The photograph was taken in September and shows the plants flowering nicely, and they did so until frost cut them off. To the left of the Lotuses a large group of the pretty rush, *Scirpus variegata*, shows its habit and horizontal marking distinctly, and on the higher ground beyond is a nice example of the planting that wedded the water garden to the lawns. First will be noticed the big leaves of the Tara plant with immense edible stems. They look like *Caladiums*. Just behind them rises a Dragon tree, *Dracena Draco*, nine feet high and planted out. To the left of it is an old cedar stump, its branches sawed off about one foot from the trunk, that is turned into a green and flowery column by a luxuriant drapery of *Ipomea palmata*, (formerly *paniculata*). To the right of the Dragon tree stands another leafy column made with *Ipomea Setosa*. Directly behind this stump stands a good specimen of the Cedar of Lebanon, and just in front of it, (although a bed of *Cannas* intervenes), is a group of the ornamental grass, *Pennisetum longistylum*, and more of the same shows back of the American agave that stands beyond the right of the Lotus bed. Above and beyond this last clump is a *Dracena indivisa*, and at the extreme right of the planting, beyond the last clump of *Pennisetum* the broader leaves of another grass, *Panicum plicatum vittatum*, is seen. It is customary here to face *Canna* beds with these two grasses planted in alternation because both are handsome, and when the *Pennisetum* is past its prime it is cut off and the *Panicum* is then so well grown that it droops over and fills the entire space until frost. It is a knowledge of such combinations that enables Park Superintendents to furnish continuously presentable exhibits from one end of the season to the other.

"A bit of the Victoria Pool" shows in the foreground a leaf that measured six feet and ten inches in diameter, including the six inch upturned rim. To say that the writer stood on this leaf and was floated as buoyantly as in a boat does not stand for much, (particularly to my acquaintances,) but I also looked on while a man who said he weighed one hundred and ninety-eight pounds (and looked it) stepped cautiously on and—was floated just as successfully. A mat was used to protect the delicate surface of the leaf and on it a slight frame of laths to equally distribute the weight, and on the frame, in the middle of the leaf, was placed a small board for one to stand on in making these novel tests.

On the farther bank in the same picture is a bed of *Cannas* edged with young *Agaves* and near by stands a large *A. Americana* in a tub, and a nice *Phoenix Balm* plunged on the lawn. In front of the last is a clump of *Cyperus alternifolius* or *Umbrella* grass growing in the water, and along the margin of the pool a floating mass of blue water hyacinths shows numerous flower spikes.

The tender plants used in this design are wintered in a cool brick store house the end of which shows in the Lotus picture. Up to this time Tower Grove Park has been supplied with extensive displays of summer bedding with no plant house—nothing but this store house. Now, however, plant houses are to be built and inadequate facilities will no longer hamper the genial and efficient Superintendent. But with plant houses *ad infinitum* he never can make a prettier display than the Water Garden of eighteen hundred and ninety-five.

*Fanny Copley Seavey.*

#### Garden Plants,—Their Geography. V.

##### POLYGALALES,

##### THE PITTOSPORUM, POLYGALA, AND VOCHYSIA ALLIANCE.

This alliance embraces four tribes, thirty-seven genera, and 717 species of often handsome plants which are rarely trees, but more commonly evergreen shrubs or climbers, and in temperate regions perennial or annual herbs. They are found in both hemispheres north and south, but a large proportion of the handsomest are from the south temperate zone, while *Vochyseæ* come exclusively from the warm parts of America.

No polypetalous plants are so sparsely represented in our gardens as these, for although we have thirty-nine or forty plants, which are natives of North America, they are mostly of humble character.

*Pittosporum* has fifty-five species, distributed in Africa, sub-tropical Asia, the Pacific Islands, Australia, and New Zealand. *P. Tobira* and its variegated variety are well known in our gardens,





POLYGALA VULGARIS.

where they do well planted out during the summer, and flower in the early spring in cool greenhouses. From the Carolinas southward, and in California, they form handsome shrubs of eight to ten or more feet high, with short panicles of very fragrant creamy white flowers. Californian gardens I believe boast two or three other species such as *P. Eugenioides* and its variegated form, *P. revolutum*, and *P. undulatum*, with its flowers still more fragrant than *Tobira*, rivalling the orange blossom in fact. Most of the species are good shrubs, with flowers ranging in color from white to yellowish, to brown, green, purple, or blueish purple.

*Polygala* has 260 species scattered all over the earth, except perhaps the extreme arctic regions. There are several beautiful shrubs in greenhouses with papilionaceous flowers, which differ materially from pea flowers however. The calyx is said to consist of five sepals, but two of these are colored like the corolla, then, two of the petals are erect, while the remaining three form a keel, within which the stamens are partially hidden with their filaments grown together. Then the anthers are one celled, and the seed vessel is a two celled capsule, while the seeds have a white protuberance at one end, all of which differs from the pea tribes. There is but one of the half shrubby kinds likely to endure at the upper south, *P. chamaebuxus*, a native of Austria and Switzerland, has creamy yellow fragrant flowers and is hardy in the south of England. Our native "gay wings," *P. paucifolia*, and its white variety, are handsome, and catalogued by two or three collectors and nurserymen. *P. aurea*, *P. sanguinea*, *P. senega* or "snake root," and the British *P. vulgare* with its humble purplish blue, rose, or rarely white flowers, may be grown by the curious.

With the exception of these two genera, the plants of the group are but little known in our gardens, although in California no doubt, several of the Australian and Cape species are grown. These plants from the southern hemisphere often flower earlier with us than in England, as they mature and ripen their wood earlier and better, and such species as are used for summer blooming are best kept quite cool in winter, for sometimes a little encouragement will induce premature bloom. The following species are mostly to be had in commerce either as plants or seeds, and are the most likely summer bloomers. Of the South African *Polygalas* such as *P. pinifolia*, *P. virgata*, *P. bracteolata*, *P. lanceolata*, and *P. peduncularis*. Then *Bursaria spinosa*; *Marianthus ringens*; *Citriobatus multiflorus*, the "orange thorn" of the Australians; are all neat plants. Among small blue flowered climbers are *Pronaya elegans*; *Sollya Drummondii*, and the "blue bell climber" *Sollya heterophylla*; *Cheiranthra linearis* is late flowering in England, but plants from the southern Hemisphere, as previously hinted, behave very differently in various countries. *Billardiera augustifolia*, *B. longiflora*, *B. scandens*, and *B. mutabilis*, are climbers of varying size, and with flowers varying in color from creamy white to purple and blue. *Tetratheca ericaefolia*, *T. rubioides*, and *T. glandulosa* are handsome little shrubs which were better known in collections years ago than now. *Platytheca gallioides* is a handsome blueish purple flowered plant of the same affinity, but these all show a disposition to flower early unless they are kept cool in winter and spring. Seeds of such Australasian plants vegetate readily if sown in a flat in a working vinery, or house of similar temperature, merely using the ordinary care to keep the soil gently moistened by light, frequent waterings. *Muraltia*, *Mundtia*, *Comesperma*, *Monnina*,



POLYGALA ERIOPTERA

Seed magnified.

Flower magnified.



Krameria, Securidaca, Qualea, Trigonon, Vochyseia etc. are *mostly* tropical American genera, two or three of which are found along the Mexican border within United States territory. It is quite true however that a very small bed will as a rule accomodate all of the plants of this alliance, even in our Botanical gardens.

*James Mac Pherson.*

#### Ornamental Bedding for Small Cemeteries.

The general appearance of the majority of village or rural cemeteries, could be vastly improved by the judicious forming, and planting, of ornamental beds covered with vari-colored foliage.

The near approach of summer should remind cemetery officials of the desirability of thus improving their grounds. In most cemeteries there are vacant spaces upon the lawns reserved at the entrance, and at the junction of roads which could be utilized for ornamental purposes, and give a pleasing appearance to the place. The beds can be made either triangular, round, oval or crescent shaped to conform to the shape of the lawn where the roads meet.

Visitors to burial grounds expect everything to have a peaceful and subdued appearance. Even the ornamental beds are better appreciated when of sombre hue. Gaudily planted beds seem out of touch with the surroundings. Having this fact in mind, a cemetery man has not the large assortment and variety of bedding plants at his disposal for decorative purposes, that can be seen in parks and other places of amusement, where everything indicates brightness and pleasure, probably there are few bedding plants more suited to cemetery decoration than dwarf cannas. The popularity of this class of plant has of late been marvelous, it being only a few years since their introduction. And this popularity is yearly on the increase. They are easy of cultivation and the tubers if carefully stored during the winter, can be used again the following summer.

If the soil in the bed is slightly raised towards the middle a pleasing effect can be obtained, by planting cannas of different colored foliage in alternate rows. Say: The outer edge green, next row bronze, next green and so on. When placed in masses of either color, the effect is also beautiful. Caladium Esculeuntum is another most desirable plant for cemetery ornamentation, and is also easy of cultivation. One of the most harmonious combinations can be had by planting the following: An outer edge of cineraria maritima (commonly known as Dusty Miller) with the next row Caladium then Cannas, either in rows or mixed with two or three castor bean seeds dropped in the centre. The

cannas and caladiums should be planted from nine to twelve inches apart, and will be much more satisfactory in every way if liberally supplied with water. A bed of this description is easily cared for, compared with other varieties of foliage plants; which is a great advantage where the services of a florist cannot be engaged. It is for such plans that this advice is designed. *B. L.*

#### The Lucombe Oak.

One of the attractions of Fairmount Park, Philadelphia, is the grove of oaks which it contains. Some of the specimens are natural growth, such as the alba, rubra, falcata, tinctoria, coccinia, obtusiloba, bannisteria and prinus, all of which are found within its boundary. A great many others, native and foreign have been added, so that the collection to-day is a very large one. The Commissioners of the Park have kindly favored me with a photograph of one which is considered a beauty, and which we give a representation of here, Quercus Robur Lucombeana, commonly called the upright English Oak. But as Mr. Charles H. Miller, the landscape



THE LUCOMBE OAK.

gardener to the park, justly observes, it is a much prettier tree in many respects than pyramidalis or fastigiata, which is the one usually referred to as the upright English oak. Lucombeana, which keep-



ing a pyramidal habit, has a wider base in proportion to its height than pyramidalis.

Both of them are excellent trees for cemetery use as well as for parks, as many superintendents of such places are finding out. Their upright habit fits them for many a position where trees of spreading growth would not answer. Such a position the one represented occupies. It stands to-day about thirty feet high, with a diameter of fifteen feet at its widest part. It is, certainly one of the finest specimens of its kind in these parts. It is rather rare in cultivation in this country, but is more common in the nurseries of Europe. The well-shaped evergreen on the left of the oak is the lovely Colorado Blue spruce, *Picea pungens*, an evergreen, the pretty color of which recommends it for public grounds. Some sprays of the Bhotan pine, *Pinus excelsa* are visible on the right of the oak. This oak has been growing in the park for about twenty years. It is placed in a portion of the park where evergreens of much the same style of growth are growing, and nicely it suits the place. What pleases many persons is to see this oak keep its foliage green until hard freezing weather comes. This is characteristic of the English oak and all its varieties, as also of the Turkey oak, *Quercus cerris*, a species much like the English, but with finely divided leaves. When our native species are bereft of foliage, which occurs after the close of November, is when these English sorts are most appreciated, and chiefly because of their green foliage at that time. Although these upright varieties of oaks often bear acorns freely, seedlings from them rarely keep their character, but revert back to the common form.

*Joseph Mechan.*

#### Ornamental Planting for Parks and Public Grounds—1.

The following extracts are taken from an "advance" copy of a paper read before the Massachusetts Horticultural Society by Mr. Wm. S. Egerton, superintendent of the Albany, New York, Parks. In this issue the matter relates mainly to the planting of larger areas or parks proper:

The fundamental elements of any large park are not its roads, walks, bridges, buildings and other accessory features requisite for the public accommodation in the use of the grounds. These may rather be classed as necessary evils. The essential element is the landscape, its surface undulations of hill and dale, or lawn; its trees, shrubs, single or in mass, in grove or copse, its deep woods or open glades, and its broad stretches of green sward or water. All of these elements in their endless combinations are constantly modified by the varying conditions of the point of view, the atmosphere, and the seasons.

The true ideal of park recreation, to persons worn by the harrassing turmoil of city life, is the refreshing enjoyment of all that may be seen and felt amid the placid manifestations of nature embodied in the landscape.

There is nothing really different in the general theory of landscape gardening as applied to the ornamentation of parks from that of ordinary grounds. The apparent difference lies in the special application to some particular individual undertaking.

In actual practice one park must be treated differently from other parks, this difference of treatment being dictated by the situation, surroundings and topography. No general plan can be outlined that would suit the demands of every locality. The general idea and keynote, however, to most successful examples of park construction in this country (and there are no better examples abroad), is the simple and natural effects, or meadow-like stretches of lawn, circumscribed or bounded by ornamental plantations properly distributed and massed. The main repose and highest enjoyment of parks reside chiefly in these spots.

\* \* \*

As a general rule each element in the scenery should be simple, natural and unobtrusive, so that the passing observer is impressed with the manner in which views are successively opened before him, through the innumerable combinations into which the individually modest elements constantly rearrange themselves; views which often possess every quality of complete and impressive landscape compositions.

\* \* \*

"A landscape in order to be beautiful, must have all its parts stamped with a common idea, and contributing to a single sensation. If it gives the lie here to what is said yonder, it destroys itself, and the spectator is in the presence of nothing but a mass of senseless objects."

\* \* \*

The landscape gardener must take into consideration all the impressive and natural elements of the locality, in the planting of any park of sufficient extent to have a distinctive landscape character. The general aim of his work will be to make a harmonious combination with the dominant characteristics which nature has already stamped upon the site. He will seek a fuller or richer development of the essential leading features, simply softening what is hard, clothing what is bare, filling out what is meagre, and enriching what is beautiful, all in harmony with the original type.

He will thus avoid all novel conceits, all conspicuous eccentricities, all incongruous intrusions,



and be guided by his understanding of the laws of nature and his sympathy with them. It is a common practice to value the decorative work in planting, on any given site, in general proportion to the degree in which it is obviously artificial, new or peculiar. Thus clumps of trees and shrubs, or beds of flowers and foliage plants, are located in conspicuous places, without fitting relation to the natural conditions of the landscape.

What is needed, therefore, is popular education with respect to the beauty, adaptability and arrangement of the component parts of successful design in landscape and gardening work.

There are fully one thousand different species and varieties of ornamental trees and shrubs, besides great numbers of hardy flowering plants, all possessing distinct features of beauty, that will thrive in the greater part of the United States.

It is an intimate acquaintance with the habit, growth and ultimate development of the greater part of these, that insures to the landscape gardener success in selecting, planting and grouping the varied specimens, so as to combine all the essential elements, in form, foliage and color, of a pleasing landscape.

Not to have an intimate acquaintance with the varied characteristics of planting material, is one of the most fruitful sources of failure in planting our parks and public grounds.

In employing trees and shrubs for ornamental planting, such a selection and arrangement should be made as will, for the number used, insure the greatest possible degree of beauty and interest attainable.

In a study of natural landscapes, it may be observed that trees, shrubs and plants bear relation to each other:

First, in the form of groups and thickets, or dense woods.

Second, in open or somewhat scattered arrangements.

Third, as single, isolated specimens.

Fourth, as wholly absent in places.

The partly open feature of a landscape is most essential, if we would have beautiful parks or public grounds. This treatment affords an opportunity for viewing the grounds at varied points; for admitting cool breezes and sunshine; for the effects of light and shadow, and most important of all, that degree of general repose and breadth, without which no park or public ground of any extent can be altogether satisfactory. The prevailing idea in planting would seem to suggest the bringing together such specimens of trees or shrubs as possess contrasting qualities; arranging these group against group, with a slight scattering of individual speci-

mens here and there, but all done for making the distinguishing and often strongly marked characteristic of one kind relieve and offset those of others without, however, too great contrasts in color.

Often a single native tree, with ample space for complete development, will, by its form and color, accentuate and bring out the contrasting features of other neighboring growths, as single specimens of our native oaks, maples, ashes and dogwoods emphasize and bring into bold relief the sometimes sombre tints of our native woods, and brighten the whole landscape in autumn by a bold dash of glowing color. It is, however, an intelligent use of this material that betokens the skilful and successful gardener.

\* \* \*

The most delightful natural landscapes show open vistas, skirted by margins of woody growth, either near or distant, which limit and support the former. A special merit of this system of planting is, that it tends to give an enlarged idea of the size of the grounds so treated. Grounds with the boundary shut off by masses of planting, and these masses arranged with irregular outlines, will look larger than they would if the boundary line were plainly in sight.

The value of a park depends mainly on the disposition and quality of its woods and planting, and on the relation of these to other natural features within its limits.

The older the wood, and the less newness and rawness there is to be seen in all the elements of a park, the better it serves its purpose. All schemes of planting are based upon orderly, seasonable adjustment, involving careful observation of the growth and development of the varied material that composes the plantations from year to year, the selection and retention of the choicest and more vigorous plants, and the removal from time to time of material for temporary purposes.

#### New Jersey Laws.

The court of errors and appeals holds constitutional, in the case of city of Newark v. Mt. Pleasant Cemetery Co., 33 Art. Rep. 396, the New Jersey "act to authorize the incorporation of rural cemetery associations and regulate cemeteries," of 1875 exempting from public burdens the property of cemetery corporations incorporated under special laws. It also holds that the provisions of that statute have not been repealed by the (supplemental) act approved March 14, 1879, and suggests a possible weakness in the latter.

#### Allows Condemnation.

The special term of the supreme court of New York for Allegheny county holds, in the case of Stannards Corners Rural Cemetery Association v. Brands, 35 N. Y. Supp. 1012, that chapter 559 of the laws of that state for 1895 makes the use of rural cemeteries public in such a sense as will permit them to acquire lands by condemnation proceedings, and that in consequence, rural cemetery associations, whose certificate of incorporation or by-laws do not exclude any person, can constitutionally secure the condemnation of lands for cemetery purposes.



## Correspondence.

*The publisher is not responsible for views expressed by correspondents, but no communications will be noticed having a personal nature or malicious intent. Communications must always be signed, not necessarily for publication but as an evidence of good faith.*

### Some Practical Suggestions.

The cemetery comes to the people as a necessity, and whether an evil or a good thing must be accepted, even with faults. Those who lived in the first quarter of the present century had to deal with the small "Church Yards," or worse still the "town plot," sometimes known as "God's Acre." The experience of this scheme generally brought the people face to face with something like a nuisance. And why? Not particularly on sanitary grounds, but rather on account of the essentially constitutional neglect that with rare exceptions followed.

With the introduction of the association principle, much better results were ardently hoped for and have been in a good degree truly realized.

An additional experience of sixty years on the Association plan, has already revealed some of the final consequences of misguided indulgence and a too lavish expenditure for what will eventually incumber, rather than improve the landscape. If the writer properly gauges the general testimony of Cemetery Superintendents, the hardest problems that come before them is to keep back the accumulation of materials that are never useful but only detrimental.

Among the needless incumbrances may be counted the family enclosure, no matter what the structure, whether of stone, iron, wood or hedge; all are needless; all become sooner or later undesirable; and, generally speaking, the more enduring the material the worse the remedy or final removal. In close relation to this same faulty indulgence is the placing of conspicuous monumental lot corners. If this device has any utility it is only as a marker and should be reduced to a minimum, durable but not conspicuous. The association should attend to this need, and never allow the lot owner to elect his own provision.

The selection of routes for drives and walks to accommodate the grounds, including family lots, combine two important principles; one strictly utilitarian, the other one of adjustment and effect. These should never be entrusted to a novice, but rather to an expert of established repute. This subject will therefore be best omitted here as not properly belonging among the topics of general instruction. Nevertheless the *care* of these elements are matters that demand frequent attention. Drives and walks should be thoroughly constructed, complete for actual use, and then maintained in good repair and condition.

A drive overgrown with grass and weeds ceases to serve any air recognition of the purpose contemplated in the plan or layout, and the same remark applies to walks. But I wish to notice here a neglect far too common in cemeteries, that is, the removal of the soil, proper enough as a first step towards making the walk, and then leaving the *refill* for an indefinite period so that the walk becomes a ditch or canal rather than for its intended purpose.

All walks should be filled flush, or nearly so with adjacent lawns, so that really no actual shoulder exists between the walk and lawn. Then the mower can pass freely over the walk from lawn to lawn without needless inconvenience. This method also insures a good appearance and effect with good clean drives and walks, we also need good lawns, these often need the support of proper fertilizers and irrigation: without thrift and vegetation they are impossible to get; with thrift and frequent clipping they are always attainable, always highly appreciated.

B. F. H.

### "The Cemetery Can Also be Made an Educator."

I copy the title of this short paper from a half sentence in our leading article of February. Further along in the same number on page 209, there are descriptions of actual work which interweave themselves with my preconceived ideas with considerable completeness. In a description of East Linwood Cemetery it is said: "It is proposed to *reserve* portions surrounding the ravine for purely ornamental or park purposes." Further it is said: "This portion of the ground is absolutely free from trees or undergrowth and will be planted and beautified entirely according to Mr. Hobert's ideas."

I am delighted to read it, for in such manner alone can a ree gardener justify his art. There seems to be some misapprehension in the minds of some of your correspondents about gardeners and garden art, engendered no doubt by an examination of work designed to set a crowd agape,—such as Echeveria horses, and Presidents in buttons. Such work is not "Landscape Gardening," but a mere exaggeration of florists wire work, which can never "educate" anyone, however much it may astonish and be marveled at. For the price of an Echeveria world a gardener, worthy his name, could select enough plants, shrubs, and trees, to teach all the children of a town the whole scheme of the Vegetable Kingdom. I repeat and wish to burn it into the minds of Park and Cemetery Trustees, that no single climate can well produce more than 3000 distinct and desirable species of trees, shrubs and plants, and that such a collection averages about 50 cents each or \$1,500. There are but few collections of hardy plants in this country which contains one-third of 3,000 desirable species. I know of small public parks which have cost well on \$200,000 where over 30,000 trees and shrubs have been planted in less than 40 species. They are not educational, and you may be absolutely certain that no Landscape Gardener ever had a word to say about them, or a thing to do with them. They were just put into the ground but more carelessly than a mason lays bricks in a wall, or a florist builds flowers in a frame.

The cemetery or the park may and should aim higher. It is easy enough to guard against "quacks and shysters" as your correspondent on page 207 calls them. If they exist, they certainly should not, if a single educated gardener lives anywhere within hailing distance. You may ask: How are you to know even a competent gardener? Well that is easy enough. Ask him to read off a page of a gardener's dictionary and explain it; if he cannot do that to the satisfaction of a Botanical Professor you may be absolutely certain that he has no business to call himself a Landscape Gardener, or a Landscape anything else.

Neither is map making landscape gardening, several of the best the world has ever known could not or would not draw. But they knew plants thoroughly, and could group them.

James MacPherson.

NEW BRIGHTON, PA. Feb. 17, 1896.

Editor Park and Cemetery:

DEAR SIR:—In reply to question of W. R. C., on page 197 of PARK AND CEMETERY for January 1896. I wish to state that several years ago I removed the remains of a full grown man, who had died from smallpox, and had been buried about fifteen years. I had no trouble at all.

Hezekiah Hulme, Asst. Supt., Grove Cemetery.

### Association of American Cemetery Superintendents.

O. C. SIMONDS, "Graceland," Chicago, President.

G. W. CREESY, "Harmony Grove," Salem, Mass., Vice-President.

F. EURICH, Woodlawn, Toledo, O., Secretary and Treasurer

The Tenth Annual Convention will be held at St. Louis, date to be announced later.



## PARK NOTES.

The Board of Commissioners of South Park, Chicago, last month ordered the purchase of 60,000 trees and shrubs, at a cost of \$4,100.

\* \* \*

The Fairmount Park Commission, Philadelphia, awarded the contract for lighting the park by electricity at the rate of \$10 50 per light per month, the lamps to burn all night, or until sunrise.

\* \* \*

By the will of the late Elsie Merritt the village of Medina, N. Y., is to have a free drinking fountain "for man, bird, and beast," and also a liberty pole from which the national flag shall float on holidays. Most of our villages offer many like opportunities to the public spirited.

\* \* \*

If a bill making a state park of the Stony Point battle ground, on the Hudson, becomes a law and the park established, it is reported that the Tuxedo Park association will build a grand boulevard between the two places which will give a beautiful drive through the mountains.

\* \* \*

Savannah, Ga., is making another stride in the march of progress. She has done much of late years in the way of public work, and she is now energetically pushing the work of permanent improvements of her park system, giving special attention to the newly acquired Colonial Park.

\* \* \*

The Commissioners of the Victoria Park,—the Canadian Niagara Falls Park,—in their forthcoming report to the Ontario legislature will review its general history from 1885 down to the present. The report will be illustrated with many views of the several properties embraced, together with maps of the same.

\* \* \*

The Adirondack state park, New York, is to be increased by the addition of 75,000 acres, for which \$600,000, or \$8.00 an acre, will be paid. The Empire state will be the gainer in the long run by this investment. Happily the acquisition of this naturally beautiful domain has been accomplished before its naturalness has departed.

\* \* \*

The will of Robert W. Ryerss, the philanthropist, late President of the Pennsylvania Society for the prevention of Cruelty to Animals, who died on February 16th at his country residence, besides many charitable bequests, leaves to the city of Philadelphia, after the death of his wife, that part of his farm near Fox Chase, with his country seat, Burholme, for a public park; to be known as Burholme Park.

\* \* \*

The annual appropriation for 1896 by the city of Cambridge, Mass., for its new park system is \$303,413. It is estimated that the complete system will cost \$2,000,000. A playground and sporting field of twelve acres will be finished this year and dedicated to public uses. This field is in a section of the city already densely populated. Another reservation of two acres will be completed this year and will be devoted entirely to the uses of small children as an out-door nursery.

\* \* \*

The annual report on the Grant Monument, Riverside Park, New York, shows total subscriptions amounting to \$515,931.91, and disbursements of \$296,729.36. The president of the association, General Porter said: The funds on hand will be just sufficient to complete the monument. The entire granite

work will be finished in June next. The marble lining in the main structure and crypt, the stairways, interior decorations, carving and the sarcophagus, will be completed in about a year, and, if no extraordinary unforeseen delays occur, the structure will be entirely finished and ready to receive the remains of Gen. Grant, and to be dedicated upon the anniversary of his birth, April 27th, 1897.

\* \* \*

In 1894, an amendment to the park act was presumed to invest the park commissioners of Rochester, N. Y., with authority over shade trees in the streets, parks, squares and avenues of the city authorizing them to remove such trees whenever required for their protection or for public convenience and comfort. In attempting to carry this out they struck a snag, two property owners obtaining injunctions restraining them, and in an exhaustive opinion Judge Yeoman held that the city had no right to remove the trees in question. The city cannot arbitrarily cut down the trees upon its public streets except in cases where it is the owner of the fee. Another side of the question in Rochester is, that the Park Commissioners have been trying to preserve a fine old elm by securing enough land about it to form a small public park. The owners of the land upon which it stands have agreed to donate land to the amount of \$500 toward the project.

\* \* \*

The superintendent of the Niagara State Reservation has asked for \$45,000 for work in the Niagara Falls Park for the ensuing year, to include grading, planting, elevators, bridges and for an investigation and report upon the operations that threaten to impair the grandeur of the falls. Since the establishment of the reservation in 1885 the expenditures for permanent improvement have amounted to \$110,000, but considerable work is yet needed. It is proposed to construct an elevator at the Cave of the Winds, at which a small fee shall be charged. The Niagara Falls Park is practically free to visitors. During the years 1885, 1886, it was maintained from receipts from the Inclined Railway, rentals from buildings and sale of old materials, and no appropriations were made. Since that date there has been appropriated \$200,000 for care and maintenance, while the receipts turned into the state treasury have been over \$71,000. Some 500,000 people have visited the Reservation each year. Since 1885 there has been saved to the visiting public in tolls more than the price paid for the grounds and their cost of maintenance.

\* \* \*

The Thousand Islands of the St. Lawrence International Park, which was discussed last year by both Canadian and American authorities seems certain of becoming a fact. A meeting was held in Ottawa, Canada, last month by official representatives of both countries, which included on the Canadian side two government officials, in which intense interest in the project was manifested. This conference resulted in an agreement to make the opening and closure laws of both countries uniform, the closed season to extend from January 1st to June 9th. Netting is to be totally prohibited on both sides of the river. The policing of the river is to be uniform, the guards of both sides co operating in all waters of the river. The territory covered by the agreement extends from Ogdensburgh on the American side and Prescott on the Canadian side to points four miles above Cape Vincent and Kingston. The Canadian government is to set aside certain islands for public parks, where those who do not own property on the river can pitch their camps. Similar parks are to be established on the American side. The government of the park is to be vested in an international commission, the commissioners named on the part of New York State being Elon R. Brown, Henry R. Heath and President Meade of the Forest Commission.



## CEMETERY NOTES.

By the will of Sarah J. Fearing, the sum of \$1,500 has been bequeathed to the proprietors of the Hingham, Mass., cemetery.

\* \* \*

More than one-seventh of the area of Newtown, Long Island, N. Y., is set aside for cemetery purposes, and it is estimated that 35,000 burials are made in the town yearly. An effort has been under way to set aside four acres additional in the heart of the village for cemetery purposes, which aroused the residents of the village.

\* \* \*

The new gateway for the South Side Cemetery at Warehouse Point, Conn., is the gift of the late Mrs. A. C. Colton, and is to be built of granite with gates of iron. It will be erected at the south gate of the cemetery and form a recess into the cemetery. On one side post is to be the date "1896," and on the other the words: "This Gateway is Erected to the Memory of I illian C. Colton by her Mother, Adelaide F. Colton." The design was submitted by Miller Bros., Quincy, Mass., and the contract has been awarded to them at a cost of \$900.

\* \* \*

The report at the annual meeting of the trustees of Oakwood Cemetery, Syracuse, N. Y., showed the number of interments for the year to be 282, and the total number on record 9,020. Total receipts including a balance of \$7,577.20 from last year were \$21,351.86; total disbursements \$11,292.40. Superintendent Chaffee reported that during the past season the amount of monumental work erected was less than usual but that the quality was better. The total permanent fund of the cemetery is now \$37,288.31 of which \$16,545 has been left to Oakwood for the care of individual lots. A large amount of grading and general improvement was done during the past year.

\* \* \*

In the report of Woodlawn cemetery, Boston, it appears that one of the most extensive improvements was the laying out of a section to be devoted entirely to single graves. The committee felt dissatisfied with the former policy of the cemetery in crowding the single graves, and determined that the people, compelled by circumstances to bury in single graves, should be treated with more consideration, therefore in laying out this territory allowance was made for a path between each two ranges of graves, making it possible for every grave to face on a path. The price of a single grave has been placed at twenty five dollars which includes one interment and perpetual care. It would seem that this is a wise innovation.

\* \* \*

The Report of Fairmount Park Cemetery Association, Newark, N. J., shows receipts from March 1895 to March 1896, including balance of March 4, 1895 of \$16,362.04 to be \$35,859.76. There was deposited for care of lots \$550.00. Expenditure \$24,701.51. Supt. Chas. Nichols reports that he laid out three new sections last year, 86 lots were sold and 593 single graves. Lots cared for, 1,574,—605 on old sections and 969 on new. 131 monuments, 69 headstones, and 70 soldiers' headstones were set. There were 1,208 interments for the year, making a total to December 31, 1895, of 30,295. There were 150 trees set out to lots. The association has some \$24,150.00 in securities, the income from which is devoted to care of lots and cemetery purposes.

\* \* \*

The report of the Board of Cemetery Commissioners for Cambridge, Mass., for 1895, shows receipts of \$17,388.56 and ex-

penditures of \$16,999.40. The receipts include burial and tomb fees, \$4,872.00; care of lots, \$3,211.31; sale of lots and graves, \$5,956.13. The receipts from sale of lots and graves was about the same as 1891, the smallest amount during the past eight years. The Board has resolved to lay out the remainder of the cemetery ground on the "Lawn" plan. A commendable interest has been aroused among the old lot-owners looking to the improvement and care of the lots, for which the Board gives credit to the superintendent. The Perpetual Care Fund amounts to \$33,657.39; the total number of lots now under perpetual care is 254, of which 57 were so placed in 1895. During the year a new Soldiers' and Sailors' lot was laid out, having room for 220 burials, upon which the several Woman's Relief Corps will place an ornamental memorial vase.

\* \* \*

Fairview Cemetery, the new cemetery of Halifax, N. S., is now open for the disposal of lots. The modern American system of cemetery improvement is rapidly being adopted in Canada, as the following points in the rules and regulations show: "There are to be no mound-graves. The sod will be cut and taken up carefully and relaid after interment in the same manner, the broken ground having been first reduced to a level surface. The sod will be always kept in good order by renewal, if necessary, and by the regular use of the lawn mower. No slab or grave mark higher than two feet, which is sufficient to record name, age, nativity and death will be permitted to be erected." One portion of the property is set aside for the purpose of fulfilling the agreement with the city authorities. The cemetery company covenant with all lot holders to care for the lots for all time. The area of the cemetery is some sixty acres, and the plans have been prepared by Earnshaw & Punshon, landscape engineers, Cincinnati, Ohio.

\* \* \*

A writer in London *St. Paul's*, speaking of the Turkish cemetery at Scutari says: The coup d'oeil is picturesque in the extreme. As far as one can see, the long slender shafts of marble rise beneath the shadow of the massive cypresses—the tree of Allah the Osmanli call it, which points its finger to the sky—while the luxuriant vegetation of the East clusters around the base of the slabs, emphasizing their snowy whiteness and preventing them from being too dazzling to the eye. Each tomb bears its own decoration. A single leaflet, the drooping petals of a rose, or graceful frond of fern indicate that a female form lies below. A turban or a fez shows that the dead person was a man. Lamps, ostrich eggs, sashes, fringed and colored handkerchiefs of varied hue, all have their own signification; while here and there will be some tall stone sculptured from end to end, its ornamentation in high relief, encircled by a number of smaller ones, which proves that the father of a family—a man of wealth, rests here surrounded by his wives and children. A curved scimitar shows that a man of war reposes there; an anchor marks the sleeping place of a sailor; a wand of office proves that the dead man held some post of command. So on, till something is learned of all, even though one may not be able to decipher the fantastic Arabic characters which tell with more detail the history of the dead. The terms in which the Turk expresses his lamentations are often very pathetic, especially when they refer to the loss of his wife or child. Here is one, taken from the tomb of a young girl, which effectually combats the common Western delusion that the Osmanli believe that women are born without souls or hope of a future life: "The cold blasts of fate caused this nightingale to wing its way to heaven. There it has found its awaited bliss. Zeinab is the name of her who lies below, and for her Lababa, who wrote these lines, offers humble petition. Weep not for her, for though dead, she has become a sojourner in the gardens of Paradise."



## Publisher's Department.

NOTICE TO SUBSCRIBERS, If this notice is marked with a blue pencil it indicates that your subscription to PARK AND CEMETERY has expired and a renewal of same is solicited.

Mr. Charles Nichols, Supt. Fairmount Cemetery, Newark, N. J., from whom all like to hear, writes: What has become of Messrs. Barker, Salway, Stone and others who from time to time in the past have contributed articles to PARK AND CEMETERY? What can be done to stir them up?

Mr. Timothy Donlan, Supt., Oakdale Cemetery, Wilmington, N. C., writes detailing his disastrous fire which destroyed the lodge. This building which was old, was used as office and waiting room, and chapel. The loss included some very valuable papers, plats of other cemeteries, many of which cannot be replaced. New quarters are being provided and Mr. Donlan will be very glad to receive from his brother superintendents such maps, plats, views of cemetery buildings and cemetery literature they can spare.

Mr. J. A. Pettigrew, formerly superintendent of Lincoln Park, Chicago, and recently in control of the Milwaukee Parks, has been appointed Commissioner of Public Parks of Brooklyn, N. Y. Mr. Pettigrew will undoubtedly make his mark on the Brooklyn Parks.

In the short sketch of the life of Mr. Robert Douglas, given in our publisher's column of January issue, it was stated that Mr. Douglas had retired from business. He writes: "This is a great mistake, for I am more heavily in the Nursery business than formerly, and have not thought of retiring."

William Falconer, Editor of *Gardening* and so well known in connection with Dosiris, the beautiful gardens of C. A. Dana, Glencove, L. I., N. Y., has been appointed superintendent of the park system of Pittsburgh, Pa. This is an excellent appointment and reflects credit on the wisdom of the Pittsburgh authorities.

### RECEIVED.

A very handsome pamphlet is that issued by the officials of Ivy Hill Cemetery, Philadelphia, Pa., to call attention to the attractions of this cemetery as a burial place, and in which a synopsis of the by-laws, and rules and regulations is also given. The photogravure illustrations are excellent, representing many views in the cemetery.

From H. W. Crawford, Secretary, Annual Report of the Fair Haven, Conn., Union Cemetery Association, for the year 1895. The report contains, in the reports

of the several officers, very interesting matters in relation to the erection of the Soldiers' Memorial Chapel, a beautiful building, designed for permanency, and containing memorial windows, and other features dedicated to the memory of the departed.

By courtesy of officials of the Cambridge, Mass., Cemetery, copies of the annual report of the Cemetery Commissioner's for the year ending Nov. 30, 1895.

From Wm. S. Egerton, Supt., Annual Reports of the Treasurer and Superintendent to the Commissioners of Washington Park, Albany, N. Y.

From Benj. R. English, Sec'y.: Annual report of the Directors of the Evergreen Cemetery Association, New Haven, Conn.

From Geo. H. Hazzard, Commissioner, Minnesota Commission State Park, St. Paul, Minn., Complimentary tickets to lectures in the interests of Interstate Park and advance copies of first lecture on "Public Parks and Reservations," delivered by Mr. Frank H. Nutter, Landscape Engineer, at Taylors' Falls, Minn., Feb. 5th. The Stationery of the Commission is embellished by views of several of the prominent features of the park.

PLANT BREEDING, being five lectures upon the Amelioration of Domestic Plants, by L. H. Bailey. New York, Mac Millan & Co.; Chicago, A. C. McClurg & Co. Price \$1.00.

This is another addition to the "Garden Craft" series, and in it Prof. Bailey, of Cornell University, Ithaca, N. Y., provides a large amount of thinking matter as well as practical information on a most interesting subject. The book contains the subject matter of various lectures by the author, which he has delivered to his students, but it supplies a gap in horticultural literature treating of the fundamental principles involved in the variations in the forms of plants. It treats of the fact and philosophy of variation; the philosophy of crossing plants; how domestic varieties originate; borrowed opinions; and pollinations, or how to cross plants.

### CATALOGUES.

Phoenix Nursery Co., Bloomington, Ill.: Catalogue of Fruit and Ornamental Trees, Shrubs, Roses. Vines, Small Fruits, Fruit and Forest Tree Seedlings.

R. Douglas & Sons, Waukegan Nurseries, Waukegan, Ill. retail catalogue of fruit and ornamental trees and shrubs.

Frederick W. Kelsey, 145 Broadway, New York; General catalogue of choice trees, evergreens, shrubs, roses and hardy plants.

The Reading Nursery, Jacob W. Manning, Prop., Reading, Mass.: Catalogue of hardy ornamental trees, shrubs and vines, hardy flowers, and large and small

fruits. Also supplementary catalogue of tested novelties. These catalogues are profusely illustrated and botanically described.

William G. McTear, Princeton, N. J., Descriptive price list of fine Chrysanthemums.

U. S. Wind Engine & Pump Co., Batavia, Ill.: Descriptive catalogue of wind-mills, towers, pumps, tanks and all kinds of fittings.

The Cottage Gardens, Queens, N. Y.: Catalogue of Carnations, Cannas, etc.

Wm. Elliott & Sons, Seedsmen, 54-56 Dey St., New York: General catalogue for 1896.

In the catalogue of Thomas Meehan & Sons, of Meehan's Nurseries, Germantown, Philadelphia, for 1896, we have an example of such work worthy of special notice. It is comprehensive, excellently and profusely illustrated, in which the descriptions may be relied upon for accuracy, and from a botanical standpoint its correctness entitles it to more careful consideration than is usually accorded this class of literature. This, of course, might have been expected of Thomas Meehan & Sons whose reputation in the field of botany stands high, but it is manifest that great pains have been taken to make the 1896 Spring catalogue especially valuable.

## Park and Cemetery PRIZE COMPETITION.

The publisher of PARK AND CEMETERY offers three prizes of TWELVE (12) dollars. EIGHT (8) dollars and FIVE (5) dollars respectively, for the three best papers on the Improvement, Care, and Management of Village and Rural Cemeteries. The papers to be limited to 1500 words.

The papers should discuss: Organization for Management; Methods for Obtaining Funds and Disbursement of same; Annual care and Perpetual care, etc., etc.

The papers will be submitted to a committee of competent cemetery officials.

Papers should be marked with a symbol in place of signature, and under separate Cover, the identification of same should be sent to be used when awards are made.

R. J. HAIGHT, Publisher,

334 Dearborn St.,

CHICAGO,

BLOOMINGTON

(PHOENIX) NURSERY.

600 ACRES.

13 GREENHOUSES.

## TREES and PLANTS

We offer a large and fine stock of every description of **FRUIT** and **ORNAMENTAL TREES**, Shrubs, Roses, Vines, Small Fruits, Hedge Plants, **FRUIT**, and **FOR-EST TREE SEEDLINGS** Priced Catalogue mailed free. Established 1852.

Phoenix Nursery Company,  
P. O. Box, 1215.  
BLOOMINGTON, ILL.



# PARK AND CEMETERY.

FORMERLY THE MODERN CEMETERY.

A Monthly Journal Devoted to Parks and Cemeteries.

R. J. HAIGHT, Publisher,  
334 Dearborn Street, CHICAGO.

Subscription \$1.00 a Year in Advance. Foreign Subscription \$1.52

VOL. VI. CHICAGO, APRIL, 1896. NO 2.

## CONTENTS.

EDITORIAL.....	233
STATUTES OF THE STATE OF OHIO.....	234
*THE MINNEAPOLIS, MINN., PARKS.....	235
*CROWN HILL CEMETERY, INDIANAPOLIS, IND.....	238
*GARDEN PLANTS*—THEIR GEOGRAPHY, VI.....	240
*CONFEDERATE MEMORIAL DAY.....	242
*GROUP OF PINES, FAIRMOUNT PARK, PHILADELPHIA, PA.....	243
*UNIFORM AND GRAVE TENTS.—CEMETERIES ON THE INSURANCE PLAN.....	244
*MEMORIAL FOUNTAIN, LAKE VIEW CEMETERY, JAMES- TOWN, N. Y.—SUGGESTIVE HINTS.....	245
REVIVAL OF USE OF FLOWERS—A CORRECTION.....	246
PARK NOTES.....	247
CEMETERY NOTES.....	248
PUBLISHERS DEPARTMENT.....	249

\*Illustrated.

IT is gratifying to note the development of the idea of improvement societies in the smaller towns for the betterment of existing conditions, and to promote interest in the care and improvement of the cemetery, park and public places. Where such interest has been secured, the change in the physical condition has been most marked. In many places it has taken the form of clearing up and renovating neglected places, removing unsightly accumulations of rubbish and debris, and imparting new life by the introduction of active care, or the addition of needed improvements. In others it has enabled the prosecution of necessary public works, and the provision of up-to-date accessories, giving an altogether progressive air to the surroundings. In either case the mainspring of the movement is sustained energy, and this can only be maintained by vigilant effort in the direction of keeping the public well informed on what is being done, and exciting its active interest by supplying it with prospective advantageous suggestions. The interest must not only be awakened but kept from flagging; this end is the main feature to be secured, and it can only be secured by continuous activity in the working membership; and the object to be attained so attractively presented as to invite hearty co-operation from the majority. In places where

improvement societies have not already been organized, the work of promoting such organizations should be taken up by the Cemetery officials, who from their experience should be well calculated to render the necessary assistance at the start, and impart such information as would lead to an intelligent inauguration of operations.

IN the circle of the months the time has again come round which in the routine of life suggests attention to the family burial plot and the labor of love involved in memorializing the departed; and ideas have so broadened out of late years, both in regard to the cemetery itself, its adornment and the appropriateness of diversity of memorials, that a wider field is presented for individual preference. The lawn plan, now the general rule in cemetery management, not alone in new cemeteries but in renovating the old, practically insists upon a limited display of stone work and that of the best. But more attention is being given to memorials of other descriptions, such as may, besides memorializing the dead serve the living, thus in a measure emphasizing the intention. So many of our smaller cemeteries need chapels and lodges, shelter houses, fountains, and appropriately too. For under the lawn plan, which unquestionably raises the cemetery into the domain of art, in its landscape attributes, the cemetery becomes a sacred burial park, and such memorials as suggested serve to complete the scheme of design, and can be made as enduring as the ordinary monument. It is not sufficiently grasped by those contemplating the erection of a monument, how much more effective is the memorial which recalls, not only to friends but to all having interest or sacred pleasure in the cemetery, the memory of the family or individual whom it commemorates. And while honoring the dead and serving the living it establishes a double purpose in its existence, besides promoting that bond of christian sympathy which is the keynote of man's brotherhood. Another notable form of memorial is the tree, and trees are nowadays quite frequently adopted for the purpose. What grander or more beautiful object to maintain the memory of the departed can be found. Transplanted in goodly size to its appropriate location on larger lots, the years come and go, only to find growth and improvement in the place of decadence, and under the control of perpetual care, a tree may be safely en-



trusted to perpetuate a memory, and "keep it green" far beyond the time when as a rule the influence of individual virtues can be recognized by human intelligence. But the majority of course are unable to provide memorials of great cost and are restricted to the memorial stone, but even in this the time has come to devote more careful attention to design. Let appropriateness for its location combined with artistic proportions be the ruling principles, and in reaching conclusions, transact the business with reliable dealers whose interest it is to promote a higher standard of monumental art. The time is now at hand for more study as to the appropriateness of memorials that they may serve the broader purpose—not only man but at the same time mankind.

---

**Statutes of the State of Ohio.**

RELATING TO THE FORMATION OF CEMETERY ASSOCIATIONS.

The following matter has been compiled and distributed by the Marion, O., Cemetery, Association. It is an excellent thing to thus keep lot owners and the public informed on the legal points governing cemetery management and control; it not only prevents misunderstanding, but in its place serves to create confidence, and a higher appreciation of official efforts towards improvement and higher conditions:

"To have a Cemetery worthy of the name it becomes necessary for some association of individuals to own and control it, who have the power of self perpetuation, so that those who buy burial lots in such Cemetery may know, that in after years, the graves of their beloved dead, and their own graves, will not be neglected, but will be kept sacred for all time. To accomplish this object the legislature of this State, (as has been done in other States and in different nations), has passed laws authorizing the forming of Cemetery Associations, with power to buy and improve grounds for cemetery purposes; to make rules and regulations for controlling such grounds, and with power to perpetuate such organizations. It is not a money making speculation as many persons erroneously suppose, for the money received for the sale of lots, after paying for the grounds purchased by such associations must all go to the support of and the improvement of the Cemetery.

SEC. 3571. A company or association incorporated for Cemetery purposes may purchase, appropriate, or take by gift or devise, and hold, not exceeding one hundred acres of land, which shall be exempt from execution, from taxation, and from being appropriated to any other public purpose, if

used exclusively for burial purposes, and in no wise with a view to profit.

SEC. 3572. Any such company or association which is limited to the ownership, by appropriation or otherwise, of a designated number of acres of land for such purpose, may purchase, according to law, additional lands to the extent necessary for such purposes; but not more than fifty acres shall be purchased in any year, and not more in the aggregate shall be so purchased and held by such company or association than one hundred acres.

SEC. 3574. After paying for such land, all future receipts and incomes of such company or association, whether from sale of lots, donations, or otherwise, shall be applied exclusively to laying out, preserving, protecting, and establishing the cemetery, and the avenues leading thereto, the erection of such buildings as may be necessary for the cemetery purposes, and to paying the necessary expenses of the cemetery company or association; no debts shall be contracted in anticipation of future receipts, except for original purchasing, laying out, inclosing, and embellishing the grounds and avenues, for which a debt or debts may be contracted not exceeding ten thousand dollars in the whole to be paid out of the future receipts; and such company or association may adopt such rules and regulations as it may deem expedient for disposing of and conveying burial lots; but any person not already the owner of a lot in the cemetery shall have the right to purchase any lot not before sold by the company or association, upon tender of the usual price asked therefor by it.

SEC. 3575. Burial-lots sold by such company or association shall be for the sole purpose of interments, shall be subject to the rules prescribed by the company or association, and shall be exempt from taxation, execution, attachment, or any other claim, lien, or process whatever, if used exclusively for burial purposes, and in no wise with a view of profit.

SEC. 3576. Every such company or association shall cause a plat of its grounds, and of the lots by it laid out, to be made and recorded—the lots to be numbered by regular consecutive numbers; it may inclose, improve, and adorn the grounds and avenues, erect buildings for its use, prescribe rules for inclosing and adorning lots, and for erecting monuments in the cemetery, and prohibit any use, division, improvement, or adornment of a lot which it deems improper; and an annual exhibit shall be made of the affairs of the company or association.

SEC. 3578. Lands appropriated and set apart as burial grounds, either for public or private use, and so recorded in the recorder's office of the county where the same are situate, or any burial-ground



that has been used as such for fifteen years, shall not be subject to sale or execution on any judgment to taxation, to dower, nor to compulsory partition; but land so appropriated and set apart as a private burial ground shall not be so exempt if it exceed in value the sum of fifty dollars.

SEC. 3580. The trustees, directors or other officers of any cemetery company or association, whether incorporated or unincorporated, may appoint as many day and night watchmen of their grounds as they deem expedient; such watchmen, and all superintendents, gardeners, and agents of such company or association stationed on the grounds, may take and subscribe, before any mayor or justice of the peace in the township where such grounds are situate, an oath of office similar to the oath required by law of constables; and upon taking such oath such watchmen, superintendents, gardeners, and agents shall have, exercise, and possess all the power of police officers within and adjacent to the cemetery grounds, and may arrest on view all persons engaged in violating the by-laws, rules, or regulations adopted by such trustees, directors, or other officers, or laws of this state in reference to the protection, good order, care, and preservation of cemeteries, and the trees, shrubbery, structures and adornments therein, and bring such persons so offending before the mayor of justice or the peace within such township to be dealt with according to law.

SEC. 3582. The receipts and income of such company or association, whether derived from the sale of lots, from donations, or other wise, shall be applied to the payment of the purchase of such lands, to the laying out, preservation, protection, and establishment of the cemetery, and the avenues within the same, to the erection of such buildings as may be necessary and to the general purposes of such company or association; no debts shall be contracted in anticipation of future receipts, except for the original purchase of the land, and laying out, inclosing, and embellishing the grounds, and the avenues therein; and no part of the proceeds of lots sold, or any of the funds of any such company or association, shall ever be divided to its stockholders or lot owners, but all its funds shall be exclusively for the purpose of the company or association, as herein above specified, or invested in a fund the income of which shall be used and appropriated as aforesaid.

The botanic gardens of the Jardin des Plantes, Paris, include some seventy acres. The plants are all labeled. Red labels denote medicinal; green, alimentary; yellow, for ornamental purposes; blue for art and black for poisonous plants.

#### The Minneapolis, Minn., Parks.

A great deal of attention has been given for some years past to the development and improvement of the park system of Minneapolis, Minn., as might be expected of this enterprising city. Indeed, such a term may be applied to the whole state which from the time that its possibilities were comprehended by its public spirited inhabitants, has exhibited a progressive advance not rivaled by any of its sister states of the union.

The general policy of park improvements for Minneapolis was originally suggested by Mr. H. W. S. Cleveland, a well-known landscape engineer, and lay upon these lines: the clearing of the territory; the opening and construction of roads and paths, and bridges when necessary; the planting of trees and shrubs; and in floral decoration of selected areas of limited extent.

The principal parks and their areas are as follows: Calhoun Terrace, 20.50 acres; Columbia Park, 166.20 acres; East River Bank Parkway, 80.50 acres; Fairview Park, 20.82; Glenwood Park, 5,710 acres; Hiyata Park, 10.30 acres; Interlachen Park, 25.50 acres; Lake Harriet Boulevard, 408 acres; Lake of the Isles Park, 154 acres; Logan Park, 10.80 acres; Loring Park, 36.06 acres; Lynedale Park, 61.26 acres; Minnehaha Park, 125.25 acres; Minnehaha Parkway, 172 acres; Powderhorn Lake Park, 52.26 acres; Riverside Park, 19.78 acres.

The above together with a number of smaller parks and parkways include a total of nearly 1,553 acres. A large amount of this is necessarily far from what it will be in the future, and besides, the problem of diverse vegetation becomes quite a difficult one in our higher range of territory, necessitating continued study and experiment. This point is being taken care of in order to introduce a larger variety of trees and shrubs, to secure that diversity of landscape effect which is the aim of advanced ideas in this department of art. But Minneapolis possesses certain features of park development more lavishly than is general,—her remarkable provision of lakes and lakelets; and in consequence of the comparative extremes of her climate, they become popular features both in summer and winter. Temporary warming houses are provided at several of the parks in the winter for the skaters, and bathing is an established summer recreation for that season.

The illustrations given herewith explain themselves. That of a scene in Minnehaha Park, presents the charm of a waterfall not only beautiful and unique in itself, but enveloped in all the glamor with which history and literature invests it. Nothing should be done here except to preserve the natural beauty, assist nature in her efforts, and provide, as





SCENE IN MINNEHAHA PARK, MINNEAPOLIS, MINN.

unobtrusively as possible, facilities for the most perfect enjoyment of the entrancing prospect. An effective water supply has been put into this park and it is here the small zoological collection is kept.

Loring Park, named in honor of Hon. C. M. Loring, late president of the board of Park Commissioners, and to whom the development of the park system is largely due, is situated in the city, and the views given in the plate display its main features.

It will be some years before the system as originally suggested will be completed, and the isolated tracts improved and connected one with the other in the finished design which the system suggests.

Mr. William W. Folwell, president of the board of Park Commissioners, in his report dated January 1896, says: "It may be that the splendid scheme of Mr. Cleveland and Mr. Loring may never be perfected in all its details, but Minneapolis will never be satisfied unless it is executed in spirit and essential features. The 'Grand Rounds' must be at length accomplished, and the enlightened generosity of citizens should be so displayed that no taxes, or but slight ones, should be needed for the territory required.

"It needs to be borne in mind that up to this time no action or consideration hardly has been had toward the acquirement of land for the large out-

lying woodland park or parks which the city will demand before the present generation shall have passed away. I may perhaps except from this statement the suggestion that should the United States government improve the lands about Fort Snelling as it has done in some other similar situations, the need of such a great woodland park may in whole or in part be met."

The Park Commissioners also incidentally give attention to street trees, and in certain quarters the trees have been greatly improved during the past two seasons by skillful attention. With the views expressed in the official reports, there can be no question that a strong desire exists to make Minneapolis in fact as well as in name a beautiful city.

Thanks are due for courtesies in preparing this article to Mr. Frank H. Nutter, City Park Engineer, Minneapolis.

#### THE INTERSTATE PARK, DALLES OF THE ST. CROIX.

The contemplation of the park system of Minneapolis brings to one's mind the proposed Inter-State park at the Dalles of the St. Croix, Minnesota and Wisconsin. The site is a beautiful one, combining grand natural scenery with other features eminently suitable to park necessities, which will afford food for reflection, study and recreation seldom found in parks so easily accessible to large cities. Mr. Geo. H. Hazzard, of Minneapolis, the Minnesota Inter-State Park Commissioner, has displayed marked ac-





THE MINNEAPOLIS PARKS.

tivity in the project, acting up to the undoubtedly correct idea, that the more quickly he can educate the people in the desirability and value of the undertaking, the more rapidly can the park be realized. In pursuance of his plan of action he arranged a series of lectures, which were delivered at Taylors Falls and St. Croix Falls, towns adjacent to the site. In a recent issue we gave extracts from the lecture by Frank H. Nutter, landscape architect, on "Public Parks and Reservations" etc., and this was followed on March 12, by one on "Origin, Peculiar Formation, Natural History and Attractive Features of the Dalles, etc." by Prof. E. E. Edwards, Ph. D. On March 18, the next lecture was delivered by Mr. Warren Upham, M. A., F. G. S. A., Secretary Minnesota Historical Society, on "The St. Croix River, before, during and after the Ice Age." The last, of which advance sheets came to hand, was delivered by Prof. Henry L. Osborn, Ph. D., on "The Mission of Public Parks with Reference to the Preservation of our Native Animals and Plants." The lecturer set forth the duties of man to mankind in this relation and described how we had been denuding the country of its natural resources in plant and animal life, and that the government had overlooked the necessity of action in this regard except in small degree. He showed

that the rescue of our native animal and plant life is possible through the agency of the public park, but advised that as the question was intricate and involved, the special authorities on the several subjects would be required to unite in order to arrive at a proper solution of the problem.

Perhaps, it may be thought, if we understood flowers better, we might love them less. We do not love them much, as it is. Few people care about flowers. Many, indeed, are fond of finding a new shape of blossom, caring for it as a child cares about a kaleidoscope. Many, also like a fair service of flowers in the green house, as a fair service of plate on the table. Many are scientifically interested in them, though even these in the nomenclature rather than the flowers. And a few enjoy their gardens; but I have never heard of a piece of land, which would let well on a building lease remaining unlet because it was a flowery piece. I have never heard of parks being kept for wild hyacinths, though often of their being kept for wild beasts. And the blossoming time of the year being principally spring, I perceive it to be the mind of most people, during that period, to stay in towns.

*John Ruskin.*





Crown Hill Cemetery, Indianapolis, Ind.

Crown Hill Cemetery, Indianapolis, Ind., one of the very largest cemeteries of the country, perhaps of the world, is situated about three and a half miles northeast of the city, on the



ENTRANCE TO CROWN HILL CEMETERY.

highest ground in its vicinity, the highest point being one hundred and eighty feet above the city's streets. It comprises nearly 432½ acres of rolling ground, very diversified in character; hill, vale, plain and dell finding expression in its modulations of surface, alternating in forest and lawn, and broadly speaking every foot appropriate for the purpose intended. It has however no water scenery.

It was established in 1863 by citizens who had been prominent in the old burial ground affairs, who called in for consultation Mr. John Chislett, then superintendent of the Allegheny Cemetery, Pittsburgh, Pa., and father of the present superintendent of Crown Hill, Mr. F. W. Chislett. Mr. Chislett strongly urged the purchase of the present site, and it was dedicated June 1, 1864. The fundamental principle of the organization was that the receipts from sales of lots should be devoted to the care, maintenance and improvement of the cemetery, with the proviso that after twenty-five years, any twenty-five corporators of the cemetery may direct the managers, if a fund sufficient for all cemetery uses has been accumulated, to appropriate a portion to the benefit of the poor of Indianapolis. This secures the property against speculative innovations. The board of managers is selected annually by the board of incorporators, and vacancies in the latter body are filled by the vote of the remaining members, thus making it self-perpetuating. Every lot owner has an interest equal to that of the incorporators.

The influence of Adolph Strauch, reflected in Mr. John Chislett, and so on to the present superinten-

dent has dominated the policy of design and maintenance. From its original wildness it has been converted into a beautiful burial park, possessing such a harmony in its general appearance, as well considered landscape work and settled policy may produce. Beautiful lawns broken into picturesque effects by groves of forest trees, artistically planted groups of shrubbery, and isolated specimens to emphasize certain features of design, unmarred by any profusion of individual memorial display, leaves a natural simplicity, restful and comforting in its reposeful influences.

Seven and a quarter miles of road traverse the grounds, formed of a fine gravel which when rolled and packed makes a road equal to macadam. Thirty-nine sections are platted and eleven more graded



SCENE IN CROWN HILL CEMETERY.



and finished, the largest lots contain 24,014 and the smallest 120 square feet respectively.

There are ten single grave sections ranging from one half to six acres in extent. No planting or monuments are permitted on single graves, and the sodded mounds must not be over 4 inches high. Headstones must not exceed one foot in height, and iron number plates at foot are set even with the sod.

As previously intimated the lawn plan is strictly enforced, no paths between the lots being discernible, and on each section more or less space is reserved for ornamental planting. No planting is allowed on lots by lot-owners, the graves are mounded 4 inches high, with rounded sides and ends, which are sodded and kept in good order by the cemetery. One monument is permitted on each lot,—headstones must not exceed 1 foot high; all foundations are put in by the cemetery. The superintendent is empowered to reject any designs considered unsightly or detrimental, and, moreover, all monuments must be of good quality of stone, marble or granite.

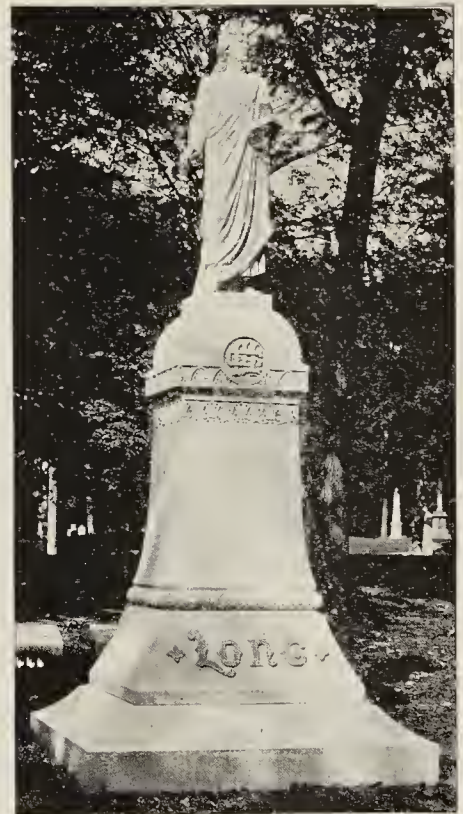
The cemetery has its own water system. The water is pumped from wells into elevated tanks by steam power, and the roads are liberally sprinkled.

Up to the present no greenhouse has been considered necessary. Close to the entrance is the combined receiving tomb and chapel, constructed of Indiana stone in gothic style, the chapel is in the centre of the building, and has

tiled floor and walls, groined ceiling of carved stone, and is lighted through stained glass windows. The vaults with a capacity of 96 bodies, are on the sides of the chapel connected therewith by heavy sliding doors. The crypts are of heavy stone, designed each to contain one casket, and the ventilation and drainage has been carefully considered. The chapel has a seating capacity of 200 and the whole structure cost \$38,922.

The total number of interments to a recent date was 23,315, the yearly average now being 1,300.

The number of men employed during the summer season is 50 which is reduced to from 15 to 20 in the winter months.



Crown Hill has a number of fine monuments marking the last resting place of some of Indiana's foremost citizens. Ex-Vice President Thomas A. Hendricks' grave is marked by a gray granite shaft twenty feet high. Not far from the Hendricks' shaft is the family monument of Oliver P Morton, the war governor. It consists of an ornate marble pedestal, surmounted by a life-size bust of that well remembered statesman. The Harrison monument, illustrated herewith, is erected by the ex-President to his deceased wife.

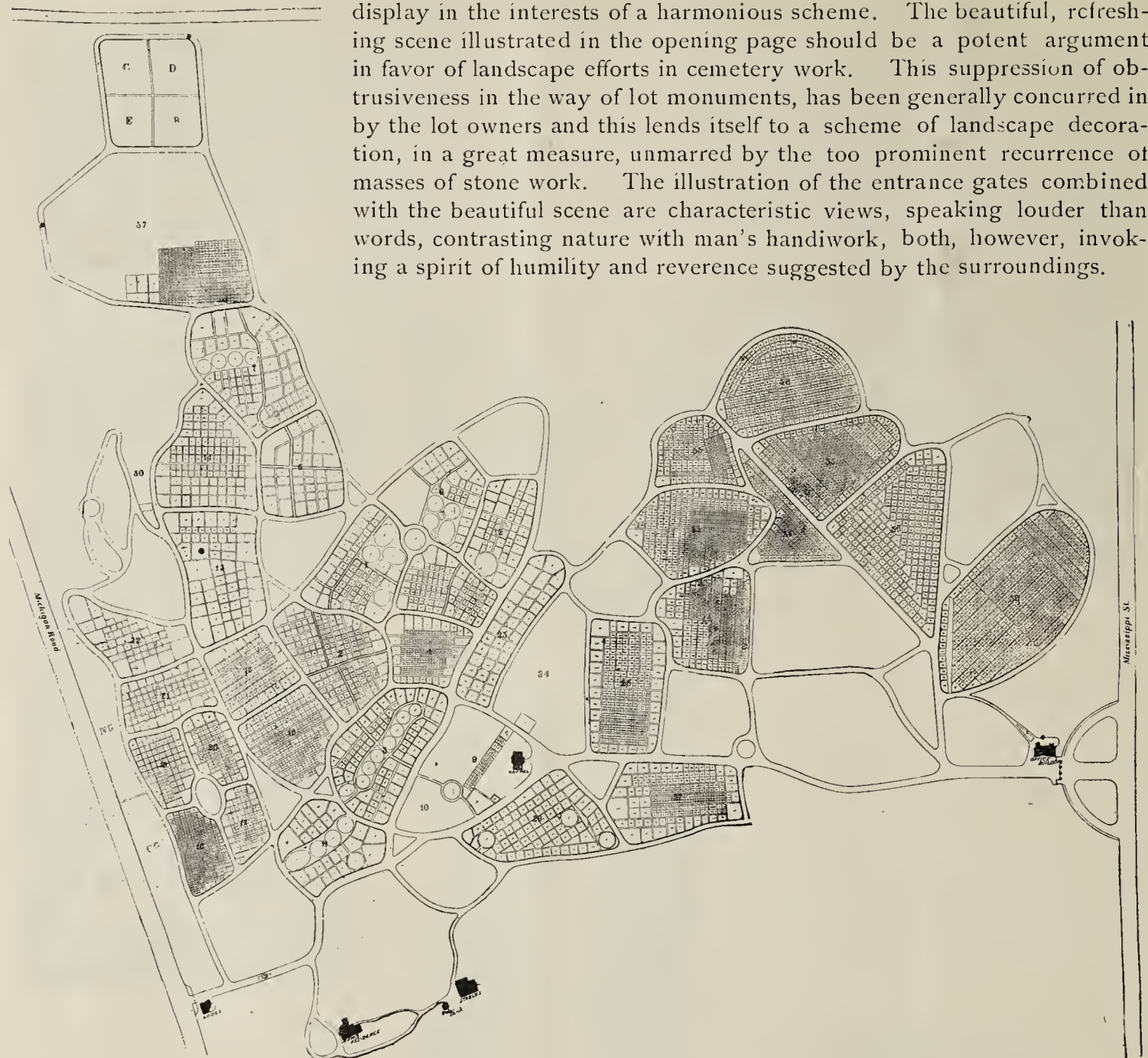


In the January, 1896, issue of this journal an illustrated description of a columbarium, in this cemetery, was given.

As before said, however, the policy of the management of Crown Hill has been to limit the tendency to individual







MAP OF CROWN HILL CEMETERY, INDIANAPOLIS, IND.

display in the interests of a harmonious scheme. The beautiful, refreshing scene illustrated in the opening page should be a potent argument in favor of landscape efforts in cemetery work. This suppression of obtrusiveness in the way of lot monuments, has been generally concurred in by the lot owners and this lends itself to a scheme of landscape decoration, in a great measure, unmarred by the too prominent recurrence of masses of stone work. The illustration of the entrance gates combined with the beautiful scene are characteristic views, speaking louder than words, contrasting nature with man's handiwork, both, however, invoking a spirit of humility and reverence suggested by the surroundings.

### Garden Plants,—Their Geography. VI.

#### CARYOPHYLLALES.

##### THE DIANTHUS, PORTULACA, AND TAMARIX ALLIANCE.

This alliance has eight tribes, sixty-three genera, and 1322 species, largely distributed over the temperate regions of the Northern and Southern Hemispheres. But few are tropical. But few are trees. Several are shrubs, but the greater number are perennial and annual herbaceous plants. Several are evergreens even in North America.

*Frankenia*—"Sea Heaths" have thirty species widely distributed over the sea beaches and deserts of the earth. *F. lævis* is a pretty little pink flowered plant growing on the Eastern coast of England. *F. pulverulenta* is one of the very rarest of Brit-

ish plants. I have the herbarium catalogue of a British botanist before me which took many years to make up, and which gives many out of the way localities—but not this little annual. It has been collected on the Sussex coast however. There are two species found in the United States. As these little trailers are mostly evergreen, the species from Siberia, the Caucasus and similar regions may be useful for rockeries and near the sea.

*Dianthus* has 225 species distributed over Europe, Asia, Africa, and N. W. America. The genus embraces the Carnations, Cloves, Picotees, and Sweet Williams, together with many beautiful species. They are so well known that they scarcely need commendation. A few of them, however,





DIANTHUS CARYOPHYLLUS.—Self type.

may be noticed in relation to their geography. The *Dianthus Caryophyllus* which gives its name to this alliance is a native of both shores of the Mediterranean. In those Southern regions it flowers early in the year but in England where it has naturalized itself upon old walls and ruins it does not flower before midsummer. The perpetual flowering class was first brought to notice in the South of France, and it is to this discovery by a Lyons gardener that our florists are indebted for their winter blooming kinds; they are referred to *D. caryophyllus fruticosus*. Many other classes have been selected, but all have their origin where the winters are mild. It might be expected that the carnation would naturalize from the Carolinas southwards, but I am not aware that it has done so. *D. alpinus*, and *D. Armeria* are sometimes found in sandy fields and on roadsides from New Jersey southwards. They are all from Europe; we have no dianthus exclusively indigenous to the United States so far as our botanies show, but I presume the Kew Herbarium boasts something from "N. W." America?

The majority of the species show a disposition to vary, and any *Dianthus* in cultivation may be watched for developments, which if recognized as superior should if possible be perpetuated. The Spaniards for instance have superior Sweet Williams which our cultivators seem to have largely overlooked. There are doubles and semi-doubles which the French call "Æillet badin." It is a curious fact that the original native country of the Pink is not known with absolute certainty. The

may be noticed in relation to their geography. The *Dianthus Caryophyllus* which gives its name to this alliance is a native of both shores of the Mediterranean. In those Southern regions it flowers early in the year but in England where it has naturalized itself upon old walls and ruins it does not flower before midsummer. The perpetual flowering class was first brought to notice in the South of France, and it is to this discovery by a Lyons gardener that our florists are indebted for their winter blooming kinds; they are referred to *D. caryophyllus fruticosus*. Many other classes have been selected, but all have their origin where the winters are mild. It might be expected that the carnation would naturalize from the Carolinas southwards, but I am not aware that it has done so. *D. alpinus*, and *D. Armeria* are sometimes found in sandy fields and on roadsides from New Jersey southwards. They are all from Europe; we have no dianthus exclusively indigenous to the United States so far as our botanies show, but I presume the Kew Herbarium boasts something from "N. W." America?



Picotee Type.



Bizarre Type.

DIANTHUS.

species of *Dianthus* not only vary but hybridize freely, and several European hybrids are described, some supposed to be between the Carnation and Sweet William and others between the Carnation and *Dianthus fulgens* etc.

*Tunica* has twelve species in Europe and Western Asia. *T. saxifraga* with bright pink flowers is effective. It is Alpine and flowers in summer.

*Gypsophila* has fifty-five species principally European and Asiatic.

*Saponaria* has thirty-five species of perennials and annuals distributed over temperate Europe and Asia. Some of them are naturalized in the United States. *S. officinalis* is one of these and has become quite common. There is a gamopetalous variety. *S. ocymoides* is a handsome low growing rosy pink flowered perennial species, and *S. Calabrica* a very pretty annual with pink or white flowers.



DIANTHUS CHINENSIS.



DIANTHUS. Hybrid Variety.



DIANTHUS BARBATUS.  
(Sweet William.)



DIANTHUS PLUMARIUS.  
Garden Type.

Levi R. Pierson, of Hudson, Mich., says the *New York Tribune*, has erected a monument for himself and wife in his cemetery lot. On one side it bears the following inscription: "Fellow-pilgrim: Help in trouble, if you get it, comes from nature, humanity, knowledge, here on this earth, nowhere else; think of it. L. R. Pierson, attorney-at-law. No charges." On the reverse of the stone is the following: "Levi R. Pierson, Harriet A, his wife. They lived and died happy, and knew just as much about the future as any human being."

By an act of the Pennsylvania legislature in 1895, it is made unlawful for any one but near adult relatives to attend the funeral of any person who has died of cholera, small-pox, yellow fever, typhus fever, diphtheria, diphtheritic croup or membranous croup. A sufficient number of pall-bearers may be in attendance.



**Confederate Memorial Day.**

The anniversary of the battle of Shiloh, is set apart as the day for decorating the graves of con-



MONUMENT TO CONFEDERATE SOLDIERS, GREENWOOD CEMETERY, NEW ORLEANS.

federate soldiers in Louisiana. On this date the sad ceremonies are carried out with the same devotion to the memory of the fallen brave as characterizes that of the north, with perhaps the added opportunities of floral sacrifice that the semitropical conditions make available. It is certain that the character of the floral offerings are necessarily more diverse and of grander proportions, due to the natural conditions of the locality, than would be possible under similar circumstances in the north. Then again the Southern women passed through such a terrible ordeal, suffered such in conceivable deprivations and hardships, that the bitter memories of what they endured serve to stimulate their sympathies into active work, and much of the elaborate decorations on the graves of southern soldiers on their decoration day, display not only the labor of love, but labor in its sterner signification of active work.

The ceremonies attending this memorial day in New Orleans, were perhaps more than usually elaborate and according to press reports were the most successful of any ever witnessed in that city. The confederate veterans were out in force, assisted by the other naval and military organizations, state and otherwise. A delegation of Mexican war veterans also participated.

The line of march took in the Lee monument,

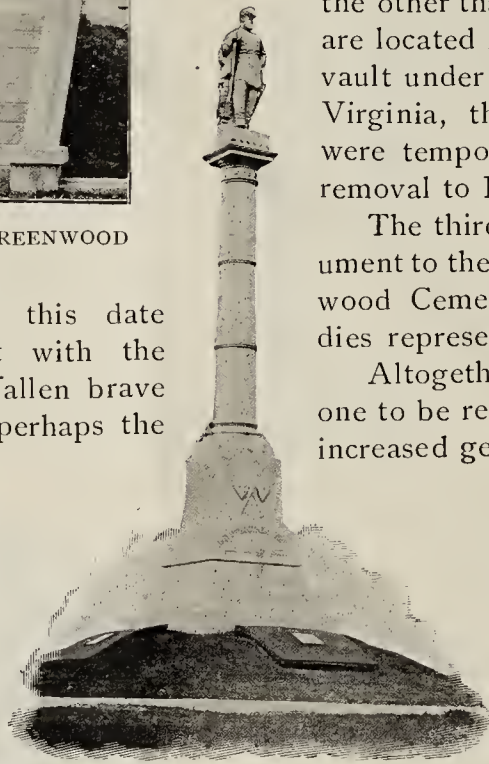
Metairie Cemetery, with its many monuments, the Soldiers Home, and the Confederate Monument in Greenwood Cemetery. At the several monuments floral decorations were deposited and salutes fired, while a formal oration was delivered at the Confederate monument.

A noteworthy incident of the day was the floral offering of the G. A. R. veterans, consisting of a massive shield of the United States in flowers, bearing a streamer of white ribbon on which in letters of gold appeared: "The Union Veterans." It was conspicuously placed on the Confederate monument.

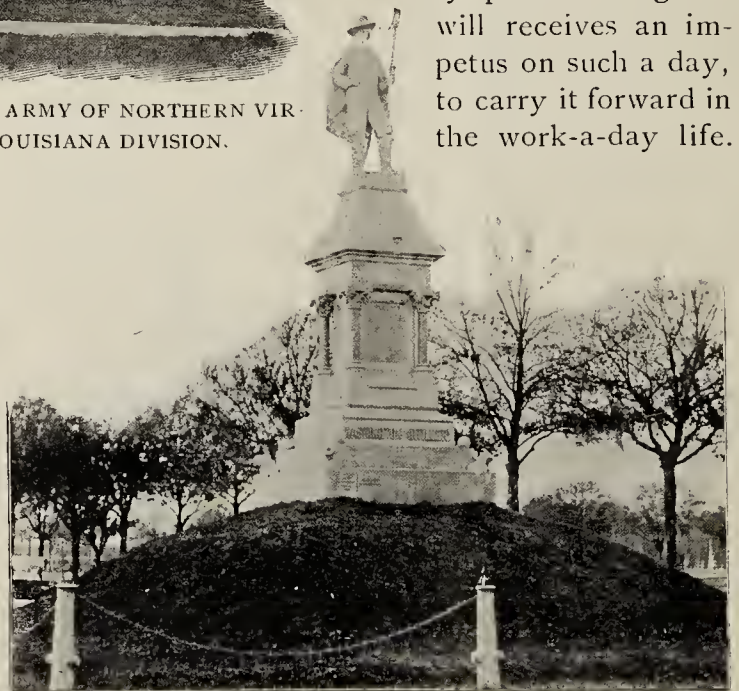
The illustrations represent three of the principal monuments that have been erected. Two of them are of granite, the one to the Washington Artillery, the other that of the Army of Virginia, and are located in Metairie Cemetery. In the vault under the monument to the Army of Virginia, the remains of Jefferson Davis were temporarily deposited prior to their removal to Richmond.

The third illustration is that of the monument to the Confederate Soldiers in Greenwood Cemetery, and the posts around the dies represent prominent generals.

Altogether, the day in New Orleans was one to be remembered, not alone from the increased general interest in the impressive customs attending the annual decoration of the soldiers' graves, but from the participation of both sides in these hallowed observances. Surely peace and goodwill receives an impetus on such a day, to carry it forward in the work-a-day life.



MONUMENT TO ARMY OF NORTHERN VIRGINIA, LOUISIANA DIVISION.



WASHINGTON ARTILLERY MONUMENT.





GROUP OF PINES, FAIRMOUNT PARK, PHILADELPHIA.

#### Group of Pines in Fairmount Park, Philadelphia.

The illustration given of a group of pines in Fairmount Park, Philadelphia presents some of the beauties of that famous resort. It is in the winter season that evergreens seem to give the most delight, but often when planted near deciduous trees the foliage of the latter seems to add to the beauty of the picture as a whole, as is the case in that before us. The two dwarf pines showing so prettily in the foreground are dwarf forms of the common white pine, *Pinus strobus*. They are extremely useful for planting in situations similar to what they occupy here, and in many other ones where dwarf evergreens of this character are wanted. There are *retinosporas*, *yews*, *arbor-vitæ*s and many other dwarf evergreens, but there are but few pines of really dwarf habit existing as species. These two dwarf white pines, though planted some twenty years ago, are now but about four feet high and six feet wide. The growth they make is but about two inches a year, or thereabouts.

The larger dwarf growing on the right is a rare one, nothing less than a golden form of the Scotch *Pinus Sylvestris*. It has beautifully golden tinted foliage, besides the dwarf habit which seems natural to it. It seems to be rare in cultivation, and I have never seen a finer one of it than this. Varieties of pines have to be propagated by grafting or in some such slower way than from seed, which accounts for the scarcity of many choice sorts.

To the left of the two dwarf white pines is what is believed to be a *Pinus Montana*, one of the few dwarf species. As will be admitted, it is a beautiful specimen. This species differs greatly in habit of growth. If a bed of seedlings be raised there

will be some plants of almost prostrate character, others low and spreading though not prostrate, and still others of the shape of growth of the one in the illustration. It partly accounts for the many names under which this pine goes, such as *Montana*, *Mughus*, *Pumilio* &c. The next to it on the right is the common white pine, *P. strobus*, one of the prettiest of pines when young, and when in good soil. And how well it stands pruning, becoming when attended to in this way, so thick that a bird can hardly get through it. To the right of this there is one which, though unnamed in the collection, is probably *Mandshurica*, an Asiatic species, of much beauty, which does well in our climate. The tall, sparsely branched evergreen showing back of the golden Scotch pine, is a hemlock spruce left to grow as it would. The first of the tall deciduous trees on the left is a black oak, *Quercus tinctoria*, a tree which, unfortunately, though of large growth, does not take on any pretty colors in Autumn. The next to it on the right is the White Ash, *Fraxinus Americana*, its finer foliage distinguishing it from the rest. The third in line is the tulip tree, *Liriodendron tulipifera*. Its magnificent growth, clean bark, dark green leaves, and magnolia-like flowers fit it nicely for planting where there is an abundance of room. The fourth tree is an oak.

Still further to the right is seen the roof of Horticultural Hall, in which are some of the finest tropical plants to be seen under glass in this country.

*Joseph Meehan.*

Rapid progress is being made in the preliminary work for the Lake Front Park, Chicago. It will be a grand improvement.



### Uniforms and Grave Tents.

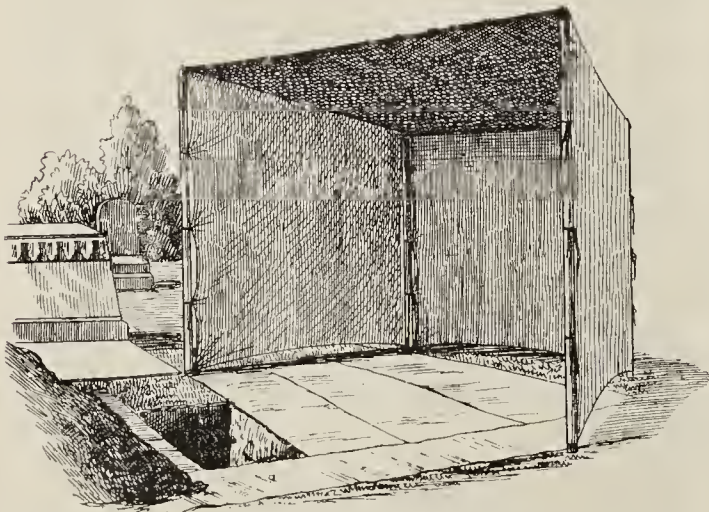
The illustrations herewith display some of the features connected with burials at Woodlawn Cemetery, New York City.



The uniform shown is worn by the grave-men at all funerals, and consists of pants and Norfolk jacket of black cheviot, with black soft felt hat. This is a commendable feature in cemetery management, and should be the rule rather than the exception, as it is. Even in many of our leading cemeteries the appearance of the men about the graves is a serious reflection upon those in control,

and is oftentimes shocking to that sense of decorum which should prevail in a cemetery.

At every funeral an open tent as illustrated is provided, together with matting and a few camp chairs. The tent is 14 feet wide in front, 8 feet in the rear and 7 feet deep, and the method of its construction, Mr. H. J. Diering, the superintendent, de-



scribes as follows: For the frame, provide four wooden poles, 3 inches diameter; two 8 feet 9 inches long for the front and two 6 feet 9 inches long for

the rear, well finished and with strong iron pin secured to the bottoms for sticking in the ground; the tops should have smaller pins. Take four pieces of galvanized  $\frac{3}{4}$  inch iron pipe of the following lengths: 14 feet, 8 feet and two of 7 feet each, provided with eyelets to slip over pins in top of poles. This completes the frame. The covering is made from light water proof canvas cut to fit the frame. Sew sides and rear pieces to roof part; put in eyelets on the side, and iron rings on front of roof portion. The setting up takes only a few minutes. Lay iron rods on ground to get position of poles; stick poles in ground, hook on the side and rear bars on top pins, slip the front bar through the rings on canvas before securing by the pins. Throw the canvas over the side and rear bars and fasten by the eyelets and strong cord to the poles. To make the tent secure in stormy weather guy ropes are of course necessary.

### Cemeteries on the Insurance Plan.

The idea of conducting a burial ground upon insurance methods, is doubtless a novelty to many cemetery officials. The notion is anything but new in Philadelphia and other cities in Pennsylvania, where the population is fixed and not migratory as in New York, Chicago, etc. Still the scheme is one worthy of consideration and can be made adaptable to any community.

Providing a place of sepulchre for a family should require consideration, the same as providing a home for the living. Yet persons hate to think of the matter, till stern necessity compels attention; and when this dreaded time arrives, it invariably finds people financially unprovided to supply a suitable place for interment, such as our hearts could wish. By the adoption of the insurance plan this is avoided.

The "modus operandi," is evidently based upon the lines of the old-time providential burial societies, and is as follows: Burial lots are sold upon the installment plan, and the business is conducted upon strictly business principles. Solicitors, of the eminently respectable class, both male and female, canvass a district selling lots and collecting the necessary periodical payments.

Should death of the purchaser intervene before all the payments are made, the company or association immediately gives a deed for the lot to the heirs, without any other consideration. But if a death occurs in the family before the lot is fully paid for and the purchaser be living, then he must make good the balance of his payments before the lot can be used for interment.

Before taking a risk, the association requires intending members to undergo a medical examina-



tion similar to that of life assurance. The number of instances where payments have had to be canceled, before being fully paid for is exceedingly small and is mostly caused by accidental death.

Well managed cemeteries operated upon insurance methods must prove beneficial to the poorer classes, and like the majority of life assurance associations are money-making institutions. *B. L.*

**Memorial Fountain, Lake View Cemetery, Jamestown.**

The accompanying illustration represents the fountain erected in memory of James Prendergast, in Lake View Cemetery, Jamestown, N. Y. Mr. Prendergast was one of the founders of Jamestown, after whom the town was named, and was one of its public spirited citizens. In addition to this drinking fountain, and close by, new iron gates,



bearing the name of the cemetery have been erected. To his family, Jamestown also owes a fine, free, public library building furnished complete, and when Mrs. Prendergast died she left \$130,000 with which to build an Episcopal Church, which was completed and consecrated in December 1894, including chimes, clock and organ, and forms one of the most beautiful churches in the State. The

fountain and gates were designed and made by the J. L. Mott Iron Works, New York City, the fountain, set up, costing \$2,000.

**Suggestive Hints.**

Cemetery officials should turn over a new leaf this year and begin early to disseminate such literature in connection with their properties as would awaken a warm and lively co-operation on the part of lot holders in their efforts to improve the physical conditions of the property. One of the most important questions relating to the welfare of cemeteries, perhaps the most important, is that of perpetual care. No effort or reasonable expense should be spared to present the matter in its most impressive sense to lot owners not yet appreciative of its necessity and benefits.

\* \* \*

It is constantly reiterated that the work of securing the co-operation of lot owners towards meeting the new order of things in cemetery design and management is so discouraging. Why is it so? In great measure it is due to the inherent objection to take for granted the statements and arguments urged by those in whom the work lies. The objection is natural and therefore difficult to overcome. Undoubtedly the most reliable course would be to distribute literature containing current opinions favoring the proposed improvements. Printers ink is more convincing than oral argument as a rule.

\* \* \*

As under the new order of things it is compulsory that individual lots should be treated in relation to the whole, having a mind to the landscape scheme, lot owners should make it a point to consult with the officials on all matters pertaining to the improvement of their lots. It is necessary that rigid rules should be maintained, but the arbitrariness can never assert itself detrimentally, when official and lot owner understand each other and the beauty of the cemetery makes itself paramount. The single lot then becomes part of the whole and shares in its appearance.

\* \* \*

In the matter of cleaning tombstones and monuments, which become stained and discolored from various causes, there are a number of methods and recipes extant, all of more or less value according to circumstances and conditions. The following are some of the formula in use:

\* \* \*

Dissolve one and a half pounds of potash and one pound of virgin wax in dilute muriatic acid by boiling it for half an hour or so. When cold the wax will float, which must then be reduced in a mortar with marble pestle to a soft paste by the addition of



soft water. This will often work when other things fail to remove stains from marble. It must be applied to the affected surface, and when thoroughly dry, must be rubbed off with wool rags. Soap and vinegar may be used instead of muriatic acid.

\* \* \*

One ounce of oxalic acid in a quart of water to which is added enough flour to form a paste will remove ink stains from marble. The paste must be applied freely to the spot and allowed to remain some days.

\* \* \*

Cleaning marble may also be effected by mixing up a quantity of strong soap lees with quick lime to the consistency of thin cream. Coat the marble with it and leave it for twenty-four hours then wash off with soap and water.

\* \* \*

The following is excellent to remove grease and dirt from marble: Two ounces of Aqua ammonia, one quart of soft water, one teaspoonful of saltpetre, one ounce of shaving soap in shavings; mix all together, thoroughly dissolving the soap.

\* \* \*

A pound of sal soda in a pail of water, and used with a scrub brush on granite and marble monuments is asserted to be an excellent cleaning wash. First thoroughly saturate the monument with clean water then apply. This is old fashioned but has the merit of simplicity.

#### Revival of the Use of Flowers.

The revival of the ancient use and meaning of flowers during the middle ages is an oasis of brightness in the gloom of those dark days of ecclesiastical fanaticism. The monks were well employed when inventing their clock of flowers or perfecting their floral directory, which assigned to each flower a particular day in the year to blossom and gave it a special saint for a tutelary genius. Thus, to the virgin they dedicated the immaculate lily and the drooping snowdrop, to the first Christian martyr the deep purple heath, to St. Barnabas the sunflower, the hyacinth and wild harebell were assigned to St. George as the champion of merry England and the "blue haired ocean." Leo the Great had to be content with the dandelion, while St. Dunstan presided over the helmet-like cowl of the deadly monk's hood, to St Augustine was intrusted the rhododendron, the sensitive plant is for St. Vitas.

During the domination of the Roman church the altars were adorned with flowers, and the great pagan Easter feast of flowers was grafted into the Christian religion; the goddess Ostara yielded her glory to her conquering rival—the holy virgin. But in the

early days of the episcopal church there threatened to be a war of the roses in the church of England, due to the bishop of Exeter and his followers protesting against the use of flowers to adorn the altars of the churches, deeming it of worldly intervention.

In the early days of the protestant church in this country there must have been a surprising dearth of flowers, for a writer in Harper's Magazine for 1863 comments with enthusiasm on the fact that in a certain protestant church in New York the altar had been adorned at Easter for the third time, and another congregation had assembled lilies, roses, violets and other flowers for the seventh time.

Thus have we dared the insidious approach of ancient pagan flower-worship, and after nearly half a century continue to use the flowers as an expression of higher spirituality. But we are awakening more and more to the ethical influence of beauty in all its manifestations, and we turn with infinite relief and gladness from flowers of rhetoric to the silent but none the less eloquent rhetoric of the flowers; eloquent for modesty, lowliness of spirit and purity.—*Chicago Record*.

#### A Correction.

It is due to Mr. G. C. Nailor, superintendent Riverview Cemetery, Wilmington, Del., to rectify an unfortunate error that occurred in the printed proceedings of the Richmond meeting of the Association of American Cemetery Superintendents. In a discussion on concrete the report credits Mr. Nailor with having presented a formula for concrete in which "50 parts" should have been written five. In the February issue of PARK AND CEMETERY, in an article on "Practical work in the Cemetery," this formula with others was reproduced and commented upon without reference to authorship. Mr. Nailor's formula was as follows: 5 parts crushed stone, 3 parts sand, 1 part Alsen's Portland cement: mixed thoroughly while dry and mixed well when adding the water. In a communication on the subject Mr. Nailor states; "During the last two years we have laid about 9500 square feet of foundations, walks and water paves, composed of the concrete formula I gave at Richmond. It had stood the frost of 22 degrees and very heavy teams have been crossing it constantly, without doing it any injury whatever. I built a greenhouse two years ago which rests upon a wall 9 feet wide by 2 feet deep, and the cellar is 7 feet deep by 16 feet square. The entire wall is made of concrete. and it has been pronounced to be a very fine piece of work. There are some very important facts connected with the composition of concrete for head-stones, monuments, etc., also in depositing it in its final resting place. Our prices for laying a foundation of concrete, is 60 cents per cubic foot under 10 cubic feet, and 50 cents per cubic foot over 10 cubic feet. Most of our work is for small jobs under 10 cubic feet, and I have been told our prices are very high. Our prices were based upon the cost of the material used for concreting as follows: We pay \$2.75 per barrel for cement, \$1.30 per yard for stone, \$1.50 per 2000 pounds for sand. I am convinced that a large percentage of men (including Engineers) do not know the exact cost of the material used in their daily work. I have frequently asked what the material used in forming a cubic foot of concrete would cost upon their own formula; the question has not been answered."



PARK NOTES.

The Park commissioners of Buffalo, N. Y., asked the Board of Aldermen for \$50,000 for a Botanical garden but the board cut it down to \$25,000. It will make a start, however.

\* \* \*

Mayor Strong of New York City, approved the bill authorizing the expenditure by the Park Department of \$350,000 for the improvement of the parks and parkways of that city.

\* \* \*

The general depression is having its effect on public improvements in many places. Work on the park system of Omaha, Neb., is practically at a standstill awaiting better times.

\* \* \*

Meridian, Miss., is agitating the question of establishing two parks, one within the corporate limits, the other out of town. Meridian is behind the times in park matters, as are most other southern cities.

\* \* \*

New Orleans is discussing the extension of the Lower City Park to take in a large area of land. Now is the time to acquire the necessary land, but the financial problem is the difficult one of the undertaking.

\* \* \*

It is said to be the intention of John D. Rockefeller and associates to expend a large sum of money in public improvements at Tarrytown, N. Y., including a public park on his own property in the vicinity of the old Sleepy Hollow Cemetery.

\* \* \*

The park commissioners of Nebraska City, Neb., appointed by Judge Ramsey under new state legislation in their petition asking for the possession of the parks from the mayor and city council, and which was refused by that body, have been sustained in the district court.

\* \* \*

The bill before the New York legislature looking to the widening of the Kingsbridge road, were it enacted would cause the destruction or removal of Edgar Allen Poe's cottage at Fordham, N. Y. A strong protest has arisen against this, and some 4000 taxpayers have asked that a park be made around it. The plan has been looked upon with favor.

\* \* \*

The proposed monument composed of stones contributed by different posts to commemorate the encampment of the G. A. R. at St. Paul this summer has been abandoned. When the matter of the location of the encampment was finally settled it was too late for action. Thus beautiful Como Park escapes for a time, at least, a threatened possible defacement.

\* \* \*

Connecticut is congratulating herself on her parks commemorative of revolutionary historic events. The Putman Wolf Den association has determined to make a public park of the interesting locality in which the "Den" is situated at Pomfret. This with the Putnam park at Redding; Fort Griswold park at Groton, and other points improved for commemorative purposes speaks well for the public spirit of the state.

\* \* \*

St. Louis has apparently been going backward in the matter of park improvement for its citizen masses. Twenty years ago there were three small parks in the centre of the city. One has since been entirely covered with buildings, another has been partially so and an effort is now being made to construct a market house on the third. As the *St. Louis Chronicle* truly says:

"St. Louis can better do without a market house than without a down-town park."

\* \* \*

*Kuhlow's* paper, Berlin, states "Of botanic gardens France has twenty-two, Germany thirty five, Great Britain and Ireland eleven, the Indian empire nine, Italy twenty-two, Russia fourteen, New Zealand three, the United States five. It is said that the finest botanical gardens in the world are situated in the islands of the Azores. When Portugal was at its prime in the great office of discovering the world, a rage for botanical specimens was current among all interested in the maritime adventures of those interesting days. The climate of the Azores lends itself particularly to the growth of the products of almost every land. The result is a series of magnificent botanical gardens in those summer islands, where may be seen nearly every tree and plant known to the early navigators."

\* \* \*

The collection of native fungi of Dr. Ellis, of New Jersey, which has been purchased for the New York Botanical Gardens at Bronx Park has been pronounced one of the most valuable collections of the kind in existence. Great progress has been made in laying out these grounds, and about 1,000 trees will be planted between the gardens and the railroad as a screen, which is much needed. Some of these trees will be planted with a view of becoming part of the permanent system, the others, quick growing, for screen only. Plans for permanent buildings are being prepared and work will begin on them as soon as they have been passed upon. The sewerage system has had great care bestowed upon it. Every point of historical interest will be carefully preserved, the landscape gardening also tending to bring out the natural beauties of the tract.

\* \* \*

According to Gericke, the great German forester, the greatest ages to which trees in Germany are positively known to have lived are from 500 to 570 years. For instance, the pine in Bohemia and the pine in Norway and Sweden have lived to the latter age. Next comes the silver fir, which in the Bohemian forests has stood and thrived for upward of 400 years. In Bavaria the larch has reached the age of 275 years. Of foliage trees the oak appears to have survived the longest. The best example is the evergreen oak at Aschoffenburg, which reached the age of 410 years. Other oaks in Germany have lived to be from 315 to 320 years old. At Aschoffenburg the red beach has lived to the age of 245 years and at other points to the age of 225 years. Of other trees the highest known are ash, 170 years; birch, 160 to 200 years; aspen 220 years; mountain maple, 225 years; elm 130 years and red elder, 145 years.

\* \* \*

The suggestions to the park police of Rochester, N. Y., by Chairman Elwood of the Committee of the Board of Park Commissioners should be noted. After stating that the rules regarding the use of intoxicants would be rigidly enforced, he said: Nothing is more dreaded by timid women and children than the officer, clothed with authority, under the influence of liquor, be it never so little. We will insist on neatness in appearance and a polite bearing and deportment at all times. And remember that you are to conduct yourselves, not only as officers, but as gentlemen, for you will have to do mostly with gentle people coming from their homes for recreation. In closing these few brief remarks, gentlemen, I want to urge you to realize that we have a common interest and should all work together from the venerable and venerated "father of our parks," all through the list, to make our parks and their management a credit to the city and a delight to the citizens and taxpayers who so generously contribute to their support.



## CEMETERY NOTES.

The annual meeting of Pine Grove Cemetery, Lynn, Mass., showed receipts for the year 1895, \$28,961.02 and expenditures \$29,658.29. The total in perpetual care fund amounts to \$87,840, increased during the year by sales of new lots and deposits on old, by \$5236. Interments during the year were 663; total interments in cemetery to January 1896, 14,996.

\* \* \*

Kensico Cemetery, one of New York's newer cemeteries, situated on the Harlem division of the N. Y. C. & H. R. R. R., 15 miles from New York city, was organized in 1874 but the first interment was not made until 1891. It is beautifully situated, and it is the endeavor of the association to make it the rival of the best eastern cemeteries. The report for 1895 gives the total number of interments as 722, of which 275 were made in 1895. In 1894-5, 39 monuments were erected at a cost of \$20,730 and 4 mausoleums at an estimated cost of \$47,000. The platted and prepared sections now include 44 acres of land.

\* \* \*

The report of the directors of Evergreen Cemetery Association, New Haven, Conn., shows that the income from sales of lots and other sources amounted to \$1,800 over that of 1894, with about the same expenditures as for that year, and that an addition of over \$800 was made to the perpetual care fund. The New Chapel Fund now amounts to \$5,800, and urgent appeals are made to help complete the necessary amount. In their report the directors say: "The development of the lawn system recommends itself more and more, and they heartily wish for the co operation of all lot owners in doing away with the old lot system, as rapidly as possible." The desirability of perpetual care is urged upon the lot owners and is rapidly finding favor.

\* \* \*

Flushing Cemetery, Flushing, L. I., contains about eighty acres of land and was founded in 1853. It has been conducted solely in the interest of its lot owners and is well kept and cared for. Since its opening six thousand interments have been made. For some years all lots sold have been disposed of under a perpetual care clause, but where perpetual care has not been provided for a fund is created by charging ten cents per square foot. This may be paid at once, or in installments with interest, care commencing with first installment. The officials are making strenuous efforts to bring the whole cemetery under this provision, and the method adopted, which is frequently brought to the attention of lot holders by the use of printers ink, should secure good results.

\* \* \*

A couple of generations ago when horses were comparatively expensive, and locomotive engines not yet introduced, it was no uncommon practice for two persons to travel upon one horse upon the plan of ride and tie; one man would ride forward and at a proper distance would hitch or tie the horse to a gate and walk on, when his companion came up with the horse he would mount, and when he had in turn left his companion at a proper distance in the rear would likewise hitch or tie and walk on, and so on to the end of the journey. Professor Darwin, in the following extract from his Voyage of the Beagle, tells of a similar course being pursued at a funeral in Chili. "We met," he says, "a party of Chilian miners in full costume—a very long shirt of some dark colored baise, with a leathern apron, the whole being fastened around his waist by a bright colored sash, his trousers are very broad and a small cap of scarlet cloth is made to fit his head closely", carrying the body of one of their companions to be buried. They marched at a very quick trot,

four men supporting the corpse, one set having run as hard as they could for about two hundred yards were relieved by four others who had previously dashed on ahead on horseback. They thus proceeded encouraging each other by wild cries: altogether the scene formed a most strange funeral.

\* \* \*

Many cemeteries organized in the past as private speculations, and consequently in some cases becoming the property of non-interested parties, do not receive the necessary care to keep them up, and become eyesores to the community. In such cases lot owners can take time by the forelock, as is the case in a Kansas City cemetery, where prominent lot owners and others concerned are organizing to raise a fund for perpetual good of the cemetery. The property has not been allowed to deteriorate, but the conditions of its ownership justify some such action as is proposed, and this should be an incentive to other communities similarly embarrassed.

\* \* \*

The annual meeting of Forest Hills Cemetery Association, Boston, Mass., showed receipts for the past year of \$138,780.67 and expenditures \$132,620.40. During the year the receipts for perpetual care, including \$40,000 matured investments, amounted to \$95,415.02, and the payments included \$16,451 for care of lots, \$431 for cleaning stones, and \$76,000 investments made. The total number of interments for 1895 was 881, making a total number of interments in the cemetery to January 1, 1896, 28,830. Total number of lots to February 1, 1896, 4572. During the year 71 monuments and 421 headstones, markers, etc., were erected; and 2 iron fences, 1 hedge and 6 curbing were removed. The average number of men employed were 90. Over 500 Perpetual Care lots were regraded, a work which will be continued this spring. More attention is being given to single graves.

\* \* \*

In the report for 1895 of Greenwood Cemetery, Brooklyn N. Y., the sales of lots for 1895 amounted to \$187,162.95, a larger amount than that for any previous year. For single graves \$14,921 was received. The total amount of receipts including balances was \$568,243.68. Among the disbursements were: Labor, \$135,664.76; Improvements, \$21,621.49; Maintenance, \$16,595.42. During the year \$143,263.26 was added to the general fund for the Improvement and Permanent Care of the cemetery, increasing this fund to \$1,848,065.32. For the Trust fund for the special and permanent care of lots, \$34,917.39 was received, the largest yearly sum recorded, increasing this fund to \$437,174.80. A hedge now completed surrounds the cemetery which in a few years will comparatively isolate it. The average number of men employed is 244; ranging between 110 and 366. The cemetery owns 21 horses and others are hired as wanted.

\* \* \*

A chapel and receiving vault combined is being built for Mount Olivet Cemetery, San Francisco, Cal., the new burial grounds now being laid out in San Mateo Co., about a mile south of Ocean View. The design is by Thomas P. Ross, architect. The style is early English and it will be constructed in rough faced rubble from a quarry in the county. On either side of the interior of the chapel conservatories will be arranged. The walls will be tinted on sand finish. The ceiling will be of Port Orford cedar waxed and oiled. It will be lighted by colored windows. The receiving vault will form the rear of the structure separated from the chapel by heavy doors. It will contain 104 crypts with marble facings each ventilated to a central tower, and each supplied with electric communication with the office. The entire building will be filled with modern improvements. Mount Olivet Cemetery was incorporated on June 11th, 1895; president, M. C. Walton; secretary, H. T. Graves.



### Association of American Cemetery Superintendents.

O. C. SIMONDS, "Graceland,"  
Chicago, President  
G. W. CREESY, "Harmony Grove,"  
Salem, Mass., Vice-President.  
F. EURICH, Woodlawn, Toledo, O.,  
Secretary and Treasurer.

The Tenth Annual Convention will be held at St. Louis, date to be announced later.

### Publisher's Department.

NOTICE TO SUBSCRIBERS. If this notice is marked with a blue pencil it indicates that your subscription to PARK AND CEMETERY has expired and a renewal of same is solicited.

The Board of Trustees of Riverside cemetery, Cleveland, O., intends erecting a new stone office building during the year, and Mr. J. C. Dix, the superintendent would like to be favored with sketches and particulars from his brother superintendents of the latest and most desirable details of such cemetery buildings to guide him in the preliminary work.

Cemeteries should entertain more earnestly the business proposition of helping to circulate PARK AND CEMETERY among their officials and lot owners. The cemeteries which have taken this course have proved it a good investment. The educational influence of such literature is of inestimable value in emphasizing the necessity of improvement and encouraging the desired assent.

\* \* \*

The following adopt the above plan: Woodmere cemetery, Detroit, Mich.; Hillsboro cemetery, Hillsboro, O.; Edgewood cemetery, Nashua, N. H.; Oakland cemetery, St. Paul, Minn.; Highland Park Cemetery Association, Kirksville, Mo.; Forestdale cemetery, Holyoke, Mass.; Woodlawn cemetery, Toledo, O.; Maplewood cemetery, LuVerne, Minn.; Forest Hills cemetery, Boston, Mass.; Graceland cemetery, Chicago, Ill.; Forest Lawn cemetery, Omaha, Neb.; Woodlawn cemetery, Dayton, O.; Cedar Hill cemetery, Newark, O.; Evergreen cemetery, New Haven, Conn.; Oakwood cemetery, Red Wing, Minn.; Ulrichsville cemetery, Ulrichsville, O.; Elm Grove cemetery, St. Mary's, O.; Fairmount cemetery, Newark, N. J.; Cathedral cemetery, Philadelphia, Pa.; Glendale cemetery, Akron, O.; Greenwood, cemetery, Zanesville, O.

\* \* \*

The following from an ex-trustee of a cemetery is to the point: "It is my opinion that no person should permit himself

to imagine that he can be of the best use on a cemetery board without availing himself of the aid your paper furnishes. I think, too, that cemetery boards would do well to make use of such a periodical to communicate with their lot owners. Is it not human nature to fall in with what is found in the newspaper, rather than take the suggestion (rather deemed dictation) of a neighbor, who may be regarded as set up in a little authority. If that which is going on in the cemetery is in accordance with what the newspapers say is "the way they are doing now," the whole matter is settled. We are in style—the board is on the right track—the kicking subsides."

The tenth annual meeting of the Association of American Cemetery Superintendents will be held in St. Louis some time in September. Mr. R. D. Boice, of Geneseo, Ill., one of the executive committee, is interesting many of the cemetery officials in the neighboring cities on the forthcoming convention.

#### RECEIVED.

History of Wildwood Cemetery, Winchester, Mass. Sixth Annual Report of the cemetery commissioners, Wildwood Cemetery, to Dec. 31, 1895.

Report of the Board of Trustees of The Greenwood Cemetery, Brooklyn, N. Y., for the year 1895.

The Kensico Cemetery, New York, Annual Report to the Lot Proprietors for the year 1895, with Rules and Regulations.

Twenty-eighth annual Report of the Trustees of the proprietors of Forest Hills Cemetery, February, 1896.

Twenty-fourth annual Report of the Board of Park Commissioners of San Francisco, for the year ending June 30th, 1895.

From Daniel J. Marsh, Park Commissioners Report for 1894, Springfield, Mass. This report is a worthy example of such literature besides being abundantly illustrated with fine half tones, it contains lists of the flora of the parks, with botanical names, classified in colors; a list of the animals and birds in the zoological section and of the wild birds, etc., that make their homes temporarily or otherwise in Springfield parks. This is a report that serves a broad educational purpose.

From Win. T. James, Supt., particulars concerning Flushing cemetery, Flushing, Long Island, and details of methods of securing perpetual care fund.

Mr. J. Y. Craig, superintendent of Forest Lawn cemetery, Omaha, Neb., has prepared plans for the improvement on the lawn plan of Forest Hill Cemetery, Norfolk, Nebraska.

Treasurers report for 1895, of Prospect Cemetery Association, Vergennes, Vermont. An appeal is made to the lot owners both for perpetual care and annual care, in order that the cemetery may be kept in good order.

Rules, Regulations and suggestions to monument builders and lot owners. Pueblo Cemetery Association, Pueblo, Colo.

Rules and Suggestions to lot owners and monument builders, Fairmount Cemetery Association, Denver, Colo.

Twenty-third Annual Report of the Board of Trustees and list of members of the Fairmount Park Art Association, Philadelphia for 1895. Contains a list of the works of art of the association; a report of the twenty-third annual meeting held April 29, 1895, and a list of members. A short biographical sketch and portrait of the famous french sculptor, Antoine Louis Barye.

Annual reports for 1895, City of Cambridge, Mass. Park Department. The City of Cambridge park reports is another instance of where the authorities believe in making such reports of permanent value and interest. Having large engineering problems in connection with the park care and development, these are carefully reviewed and illustrations given of important features.

A new insecticide, safe, convenient and effective in protecting trees is what is known as "Dendrolene." It was originated at the New Jersey Experiment Station and is recommended by Prof. Smith. It is an effectual remedy against tree borers, canker worms, and other such destructive pests, and is harmless to the tree. The field for an effective remedy is a large one, as all know the constant work and unremitting care necessary under ordinary conditions to fight the insect life which preys upon our fruit and other trees and shrubs. Dendrolene is applied around the trunks in some cases, and about the branches in others, and proper application as directed will be an active and efficient preservative against the destructive effects of such forms of insect life.

THE SPRAYING OF PLANTS. A Succinct Account of the History, Principles and Practice of the Application of Liquids and Powders to Plants for the Purpose of Destroying Insects and Fungi. By E. G. Lodeman, Cornell University. MacMillan & Co., 66-5th Ave., New York; Chicago, A. C. McClurg & Co. Price \$1.00.

This is another of the valuable series of works, issued in cheap and convenient form, of the Rural Science Series,



edited by Prof. L. H. Bailey, of Cornell.

It is remarkable what progress has been made in the last few years in the knowledge of the destructive agencies of insect and fungus at work in our farms and orchards, and in the means of extirpating such agencies. Like other books of this series "The Spraying of Plants" is full of practical information. It gives the history and principles of spraying, describes the various preparations in commercial use, the history and progress in such work in this and other countries. The formulas for preparations as well as descriptions of the devices and machinery. The action of insecticides and fungicides. Specific directions and the laws of various states on the matter. An immense amount of valuable information in an accessible form.

CATALOGUES.

Descriptive catalogue of the William H. Moon Co., Nurserymen, Horticulturists and Landscape Architects; Glenwood Nurseries, Morrisville, Pa.

George B. Moulder, Lily Park Gardens and Greenhouses, Water Lilies, Aquatics, Greenhouse Plants, Ornamental Shrubbery. Smith's Grove, Ky.

Descriptive catalogue, Kissena Nurseries, Parsons & Sons Co., L't'd., Flushing, N. Y. Hardy Ornamental Trees, Flowering Shrubs and Vines.



**STEEL WEB Picket Lawn Fence**

Steel Posts, Steel Rails and Steel Gates; Steel Tree, Flower and Tomato Guards; Cabled Field and Hog Fence, 24 to 58 in. high; Poultry, Garden and Rabbit Fence; Steel Wire Fence Board, etc. Catalogue free. DeKALB FENCE CO., High St., DeKalb, Ill.

**THE SUPERINTENDENT'S LIBRARY.**

**Landscape Gardening**, by Samuel Parsons Jr, Supt. of Parks, New York City. Notes and suggestions on Lawns and Lawn Planting. Laying out and arrangement of Parks, etc. Deciduous and Evergreen trees, shrubs, flowers and foliage—Ornamentation of Ponds and Lakes. 300 pages, nearly 200 illustrations. Beautifully printed and bound. A charming book for landscape gardeners. Price \$3.50. With the Park and Cemetery one year, \$4.25.

**Ornamental Gardening for Americans**. By Elias A. Long. A treatise on beautifying Homes, Rural Districts, Towns and Cemeteries. A most valuable contribution to Gardening Literature. Treats on the materials required, the arrangement, construction and maintenance of gardens for homes, parks, cemeteries, etc., profusely illustrated. Cloth, price \$2.

**The Nursery Book**, by L. H. Bailey, assisted by several of the most skillful propagators in the world. In fact, it is a careful compendium of the best practice in all countries. It contains 107 illustrations, showing methods, processes and appliances. How to propagate over 2,000 varieties of shrubs, trees and herbaceous or soft stemmed plants; the process for each being fully described. All this and much more is fully told in the Nursery Book. Over 300 pages, 16mo. Price, cloth, \$1. Pocket style, paper, narrow margins, 50 cents.

**ALTERNANTHERAS**

A. Nana, R. Nana, P. Major and Versicolor, well rooted cuttings in any quantity at \$4.00 per 1000. Would like to make contracts for pot grown plants for May or June delivery. Write for prices.

A. J. BALDWIN, NEWARK, OHIO.

**FOR-GET-ME-NOT**

Blue Perfection

A PROFITABLE CUT FLOWER.

This flower is a saleable and profitable cut flower, and has averaged at wholesale in Philadelphia market this winter, from \$1.50 to \$2.00 per 100 flowers.

READ WHAT TWO OF THE OLDEST AND BEST KNOWN HOUSES IN PHILADELPHIA SAY ABOUT IT.

MR. ALBERT KNAPPER—This season we have worked up quite a little trade on Myosotis and consider it a good cut flower for the retail florist, which I think will grow more in favor.

MR. ALBERT KNAPPER—We take great pleasure in recommending a good article and can say that your Myosotis is a fine, large, strong flower of a grand color, and the best we have seen for a great while.

**A Good Investment, Easily Handled.**

**A Good Keeper, No Disease.**

**A Good Seller, Order Now.**

Treatment similar to Violet Marie Louise or Carnations, from 40 to 50 degrees  
Plants, 2 inch pots, ready for shipment, per 100, \$5.00; per 1000, \$40.00. Rooted Cuttings, ready for shipment, per 100, \$3.00; per 1000 \$25.00. Cash with order please or C. O. D.

**ALBERT KNAPPER,**

**Frankford, Philadelphia, Pa.**

**JOHN H. JACKSON Successor to JACKSON BROS. Established 1852.**  
NEW YORK STATE DRAIN TILE and PIPE WORKS. Main office 123d Av Albany, N.Y.



Manufacturer of and Dealer in Agricultural Drain Tile, Salt Glazed Sewer Pipe, Red Pressed Brick, Mortar Colors, Fire Brick, Oven Tile, Chimney and Flue Lining, Chimney Tops, Fire Clay Stove Pipe, Fire Clay, Kaolin, Encaustic Sidewalk Tile, Rosendale and Portland Cement, Lime, Plaster, etc.

**SITUATIONS WANTED, Etc.**

Advertisements, limited to five lines will be inserted in this column at the rate of 50 cents each insertion, 7 words to a line. Cash must accompany order.

Wanted—A position by a young married man who is a good landscape engineer with practical experience as secretary or superintendent of a cemetery. Willing to start a new cemetery and lay it out. Can show plans of work done and give testimonials from the best cemetery managers in the country. Address R. I., care of PARK AND CEMETERY.

Situation wanted—Cemetery Superintendent with sixteen years experience, desires position. Good general knowledge of the work. Strictly temperate. References furnished. Address, Eastern, care PARK AND CEMETERY, Chicago.

Situation wanted by experienced superintendent, Park or Cemetery, practical in all details. Good Landscape man, preparing new grounds a specialty. Best of references. Supt., care of PARK AND CEMETERY.

Situation Wanted by an experienced superintendent, practical and thoroughly experienced in every respect. Preparation of new grounds a specialty. First-class testimonials and best references. Address R. A. L. care of PARK AND CEMETERY.

**JAMES MCPHERSON,**

LANDSCAPE GARDENER TRENTON, N. J.

Plans, planting material, the selection of sites, and supervision of arrangement for parks, arboreta, college grounds, and gardens. Sound practice and reasonable terms.

**FENCING**

For HOGS, POULTRY, and all fence purposes.



Standard Fencing of U.S.

Thousands of Miles in Use. Always gives satisfaction. Sold by dealers. Freight paid. Take no other. Catalogue free. McMULLEN WOVEN WIRE FENCE CO., CHICAGO, ILL.

**DON'T** buy worthless nursery stock and **WASTE** many years of VALUABLE **TIME** waiting results and finally lose your **MONEY**. But send to the



**MOON**

Company who have the

**FINEST NURSERY STOCK**

at Reasonable Prices.

New Catalog for 1896. Send for one. Free.

Estimates furnished. Correspondence solicited.

**THE WM. H. MOON COMPANY, Morrisville, Pa.**



# PARK AND CEMETERY.

FORMERLY THE MODERN CEMETERY.

---

A Monthly Journal Devoted to Parks and Cemeteries.

---

R. J. HAIGHT, Publisher,

334 Dearborn Street, CHICAGO.

---

Subscription \$1.00 a Year in Advance. Foreign Subscription \$1.52

---

VOL. VI. CHICAGO, MAY, 1896. No 3.

---

## CONTENTS.

EDITORIAL.....	251
ORNAMENTAL PLANTING FOR PARKS AND PUBLIC GROUNDS, II.....	252
*THE CUSTER BATTLEFIELD CEMETERY.....	254
SANITATION IN BURIAL.....	255
ADOLPH STRAUCH'S MONUMENT.....	256
*A FRENCH MEMORIAL.....	257
*SPRING FLOWERING TREES AND SHRUBS.....	258
*GARDEN PLANTS—THEIR GEOGRAPHY, VII.....	262
LEGAL.....	263
RULES FOR RECEIVING TRUST FUNDS—CORRES- PONDENCE. ....	264
PARK NOTES.....	265
CEMETERY NOTES.....	266
PUBLISHERS DEPARTMENT.....	267

\*Illustrated.

---

THE advent of spring naturally draws attention to the outdoor requirements and duties which face us year after year, and nowhere perhaps, does outdoor work demand more prompt consideration than in the cemetery. There is no time to lose, under the best conditions, on account of the shortness of the season in our northern latitudes; but as the length of the season is practically arbitrarily determined by Decoration Day, cemetery superintendents have to use every exertion and avail themselves of every opportune incident to ensure the best possible appearance of the properties under their care in readiness for the observance of the day, and the crowds of visitors who annually participate. And it is not only the labors incidental to landscape gardening that are involved in the preparation for memorial day, but spring exercises its beneficent influence on everybody, and leads the thoughts of those interested to the burial lot. This, and the fixed

date of the day to be observed, has brought about the custom of ordering monuments so as to have them set and the lots made presentable for this particular occasion. The effect of this condition of things is to make the months of April and May the busiest of the year, not only for the cemetery superintendent but for the monument dealers also. However, the compensation lies in the fact that the conditions being quite universal, our cemeteries become objects of interest and beauty at the time when nature is at her best, and that the beautiful sentiment hovering about the practice of bedecking the graves of the nation's dead, finds its harmonies in the peace and rest which hallow the surroundings, notwithstanding the tendency of the crowds is to despoil rather than to respect the beautiful conditions about them.

ARBOR day is a growing institution, to the observance of which, however, increasing attention should be paid. Its exercises might with advantage be extended, and not only one tree, as is often the case, but a number of trees in desirable localities be included in the program. Quite a number of our states recognize the day and the several governors issue proclamations for the occasion. In some portions of our vast domain, comparatively few trees are to be found; others, which, within but a few years were covered by dense forest growths, have been denuded, for commercial purposes, owing to a laxity in our laws on this important question. In either case a liberal and general observance of the institution would in a very few years create new conditions, adding beauty and comfort to treeless vistas and enhancing property values in a rapid ratio. Especially valuable to our village parks and cemeteries could labor day be made, and it would be a very businesslike proposition for the management of such properties to emphasize the governor's proclamation, by addressing their local schools, other institutions and cemetery lot owners to practically observe the day by planting a tree or shrub, under expert guidance, and directions. If such an effort were made, how soon would our village common and graveyard put on a better appearance, and create a more respect-



ful attention to its crying needs. It is quite possible in any locality to create an enthusiasm for such work, if business vim and practical knowledge combine in the endeavor. The result in a short time would be as convincing in its effect as the necessity is now so generally apparent.

THE entrancing beauty of our public parks in the spring season, when bud and blossom vie with each other to create a harmony of delightful tones and tints, as nature awakens to fulfill her summer's destiny, brings to the student, whether official or otherwise, new suggestions or emphasized old ones, as the case may be. In this age of improving knowledge of nature's laws, both the public park and cemetery bear an important part. They are the main exponents of the art of the landscape architect or gardener, wherein by the more intimate knowledge of trees and plants and nature's methods of arrangement and design, acquired by special study and innate bent, effects are produced of so varied range and proportions, that within the limits of the single park or cemetery we may refresh our senses with landscape pictures so different in detail and coloring, that long days of travel might fail to realize for us. In this very fact rests the idea of valuable educational privileges; for to learn to appreciate nature's wisdom in connection with her limitless resources, all to be in part appropriated by the faithful observer, elevates and inspires the inner man to higher thoughts and higher aims while relatively refreshing his physical being. But this appreciation creates an appetite to learn more of the physical details of the effects which produce the impression, and there follows the desire to know what tree is this and what shrub is that? And here most of our parks and perhaps all our cemeteries declare the inquirer must seek no farther. The why not is undoubtedly expressed in the view that, the importance of naming the trees and plants in our parks has been generally overlooked. That it is important, the awakening public interest in landscape work asserts, even without the larger fact that the study of botany as well as horticulture is being pursued with avidity by large classes in our public institutions of learning as well as, in a primary sense, our public schools. Our public parks, and why not our cemeteries, should be object lessons in this direction, and would form excellent aids not only in imparting practical knowledge, but in aiding to retain that knowledge by those separated by conditions from its centres. Park commissioners should not delay any longer the work of labelling the trees and plants on their properties, and it will be found an effective agent in increasing public regard for their parks and recreative grounds.

#### Ornamental Planting for Parks and Public Grounds—II.\*

The value of public gardens, places or greens, in distinction from parks, is dependent less on the extent of their sylvan elements than on the degree of convenience with which they may be used; these being the most valuable, other things being equal, through which the greatest number of people may be induced to pass while following their ordinary occupations, and without serious hindrance or inconvenience.

Neatness and the maintenance of orderly conduct among visitors in such a ground becomes also exceedingly difficult. It is much better to plant and decorate them in such a manner as will not destroy their openness or cause inconvenience to those who have occasion to cross them. For this purpose their plans should be simple and generally formal in style, their passages should be broad and direct, and they should be provided with seats in recesses (preferably) or on the borders of the broader paved or graveled spaces, leaving ample room for free movements. The green effects of the grass, accentuated by the shadow effects of trees, properly selected and grouped, should be made the chief and most important feature of their treatments. The trees should be high stemmed and umbrageous; flowers and delicate plants, little used except in vases or as fringes of architectural objects.

Architectural adornments may properly be employed in small parks, so long as they do not seriously interfere with the open grass effect. There may be even busts or statues (if artistic in design), but especially suitable are drinking fountains, and fountain basins, with great sprays of water. The fountain basins may be effectively ornamented with lotuses, water-lilies and other decorative water plants. All such adornment of small city squares or greens tends to appropriately enliven and enrich the general appearance of a crowded city, where the effect of everything is artificial, and more or less formal or tedious.

In the city, \* \* \* it is better to plant certain hardy, deciduous trees and shrubs, such as the privet, weigelia, snowball, spiræa opulifolia, American thorn, Philadelphæus, honey-locust, American linden, Norway and Sugar maples, and the Oriental plane trees, than to meet with failure by the introduction of other less hardy material.

The Persian rug in flower or foliage plants is an admirable thing properly placed, but then it is not always in harmony with the natural effects suitable to a special surface of greensward. Carpet or ribbon gardening, artistically composed, is both

\*Extracts from paper read before Massachusetts Horticultural Society by Wm. S. Egerton, Superintendent of Albany, N. Y., Parks. Concluded from March issue.



right and proper in its way, only it should be subordinated to, as well as co-ordinated with, other compositions of color throughout the entire system of planting on any special lawn. Color, for almost everyone, is a great and positive delight. This delight may be more sensuous and less purely intellectual than that inspired by agreeable form, but it belongs more truly, nevertheless, to the restful physical pleasure associated with the lawn.

A knowledge of plants, and the possession of an adequate supply, does not always insure a satisfactory grouping and massing of them. There is needed an artistic sense of form and color effects that, if not inborn, comes only with observation, reading, and an innate love of the beautiful. \* \* \*

In addition to this special fitness, there must be a general plan, carefully studied, as to its application to the locality and surroundings to be treated.

A ground plan should be made, drawn to a scale, of the locality to be embellished, the beds or groupings located, and carefully studied as to perspective and outline. The plants should be selected with reference to height, form and color for each individual bed, simply considered as a part of the general scheme for the whole plan of decorative work. In this way only can a complete and satisfactory result be secured.

The same careful study should be made by the gardener for any plan of ornamental planting, either of trees and shrubs or of purely sub-tropical and floral decoration.

In the smaller city parks or places such a gardener would construct as direct and broad lines of transit as would be consistent with easy and graceful lines; he would secure ample lawns and umbrageous trees; he would mass the shrubberies, if used, in groups of a kind for effects of color in flower and foliage; and, if flowers are used, he would harmonize these, by the introduction of sub-tropical or foliage effects with the other features of the park, without too glaring a transition from the natural to the artificial form of embellishment.

To do all this involves a careful study of the growth and habits of plants, the proper composition of soils to produce the best results, a knowledge of form and color to properly group and blend the many combinations of leaf and flower, that modern introductions have made available, so as to combine effects that will be in harmony, and present a picture that will heighten, and not mar, the main features of the garden.

Where detached masses of color are desired, this effect is secured by massing larkspurs, hollyhocks, sunflowers, tall phloxes, lilies (candidum and auratum), and pyrethrums, in solid blocks, each variety

in a bed or bay by itself, thus securing color effects long after the shrubberies have ceased to bloom.

In these borders and generally throughout the park, (Washington Park Albany, N. Y.) the plants or groups are properly named, thus affording the public an opportunity of becoming acquainted with the many varieties of plants used.

The term sub-tropical is popularly given to flower gardens embellished by plants having large and handsome leaves, noble habit or graceful outlines. It simply means the introduction of a rich and varied vegetation, chiefly distinguished by beauty of form, to the ordinarily flat and monotonous surface of the garden.

Selection of the most beautiful and useful from the great mass of plants known, is the gardener's pride, and in no branch must he exercise it more thoroughly than in this. Some of the plants used are indispensable—the different kinds of Ricinus, Canna in great variety, Colocasia, Palms, many fine kinds of Dracaenas, Yuccas, Agaves, Cycads, Pampas grass, Arundos, Rheums, Acanthuses, Wigandias, Rhus-glabra-laciniata, Aralia Japonica; all of these, and more, are used to good advantage.

Where such plants are not available, by a judicious selection from the vast number of hardy perennial plants now grown in this country, and by associating with these flowering shrubs selected for special grace, height and beauty of outline, a permanent garden can be secured that will, with but little care, outrival in beauty any attempt at formal bedding upon the old lines of carpet work, and never cease to be a "thing of beauty and a joy forever".

The true motive is for a restful, quiet arrangement of border planting and grouping, for harmony in color, and not for glaring, striking, effects. Much of this effect is secured by the aid of foliage plants, and not with flowers.

The design of this paper has been to moderate or curb the tendency of too generous a use of flowers, arranged in geometric or formal designs, either in urban or suburban parks: to concentrate such effects, when used, to localities especially adapted and heretofore suggested for such displays, and to blend such exhibits with their immediate environment, by shading down the tones, so that, to the observer, the transition may be gradual, from the natural to the artificial, or vice versa, without too sudden a change in form or color; furthermore, to use fewer flowers and more foliage plants.

Scattered, detached effects are to be avoided. Treat the garden as one composition, each bed or group of plants being a necessary and integral part of the whole picture.



Avoid scattering effects in the planting of shrubs or trees. Either mass for color effects in foliage or flower, or select for grouping, such shrubs as are noted for individual form and expression, giving ample room for development, and space to view them from all sides.

Rely mainly upon the lawn, and natural effects of trees and shrub planting, for the impression to be made, and subordinate the artificial to the natural.

#### The Custer Battlefield Cemetery.

On the 25th of last June, the nineteenth anniversary of Gen'l Geo. A. Custer's death, we paid a visit to that sacred spot on the Little Big Horn, Custer's battlefield.

The completion of the railroad from Sheridan, Wyo., to Billings, Mont., on the Northern Pacific, has brought this battlefield into touch with the outer world, and tourists in the northwest and army officers are now visiting this field, and they are trying, by study, to unravel the mystery of the greatest battle since the civil war. A battle fought from beginning to end, with intelligence and discipline, and with a heroism that has never been excelled,— a battle and a sacrifice.

Senator Beck, of Kentucky, who visited this place, several years ago, was instrumental in inducing the government to build a stone lodge for the sexton, and in securing an appropriation for marble headstones, which were set in place of the wooden ones that marked the spots where each of the soldiers fell. And to day these white sentinels which dot the field, tell the story of the struggle and help in a way to solve the shadow of an awful mystery that will ever rest upon these barren, blood-dyed hills.

The battlefield is a national cemetery now, and the remains of all soldiers who have been killed upon the plains and valleys of this section of the country are being gathered here, and properly buried, with tombstones and monuments to tell in after years, stories of duty, heroic deaths, and the cruelty of wars. Each marble headstone tells where fell "a member of the 7th U. S. Cavalry, June 25th 1876." On the highest point of the field stands a huge granite monument, on the sides of which are inscribed the names of officers and men who fell on that ill-fated day.

The relic hunter used to come here and hack and deface this monument, until the government was compelled to place a tall iron fence about it. Near this monument is the spot where Gen. Custer fell, marked by a huge wooden cross.

It is the general supposition, we believe, that Custer and his little band were led into a dark,



THE CUSTER MASSACRE MONUMENT, CROW AGENCY, MON.

deep ravine, and slaughtered. Nothing of the kind though. The field is a succession of brown, rolling hills, divided by deep gullies, any of which could contain an army of soldiers, and which were no doubt utilized by the Indians. The whole country, away from the river, is a wild, rocky region, with bold mountainous hills, devoid of shrubbery, and with wild, dashing, mountain streams.

The Indians when approached on the subject, refused to talk in most instances; but now and then little bits of information leak out and these with a study of the field makes the story somewhat plain. Gen'l Custer and Major Reno, had been following the trail of 1200 or 1500 Indians for several days. On nearing the Indian village on the 25th of June, that year, they divided their forces of 800 Cavalrymen. Reno was to move down to the river, cross it, and attack the lower end of the village; Custer to swing around on his right flank and cut off a retreat of the enemy. Reno attacked the Indians at noon, but he met with such a hot reception, that he was forced to retreat, having lost about 40 men in about twenty minutes. He retreated across the river and back to a hill  $4\frac{1}{2}$  miles from the field. Here he intrenched himself and waited for two days until Gen. Terry arrived; the intrenchments are plainly to be seen to this day; so dry is the climate and rain rarely falls in this country.

Custer in the meantime had made a detour of the Indian village, keeping out of sight in the hills. At two o'clock he moved down to the river, and coming around the point of a mighty hog-back, he



was at once engaged. Instead of meeting 1500 Indians under Santanta, he was met by not less than 6,000, under Chiefs Gall and Rain-in-the-Face. It became a death grapple from the first. Custer threw out a strong skirmish line; every one of the skirmishers were slain and the marble headstones which tell where they fell are beautifully aligned. As the main body moved into action, great masses of the enemy rose from in front of Custer out of the gullies and swung around to his back; on the first hillside he divided his command, and sent two companies of sixty men down the left side of the hill, while he kept to the right in a parallel line advancing into a deep ravine. Here he met with terrible opposition, and was cut off from the others. With his thinned ranks he kept advancing, however until he reached the high ground where he met his death. On reaching the top of the hill, the separated command caught sight of their leader and made a heroic struggle to reach him. They fell in fours, by twos, and singly; you can count the stones, sixty in number. Could anything be more pitiful. When Custer reached the top of the hill, 1000 fierce Cheyennes, under the satanic "Rain-in-the-Face," rose up from the ravine, in front of Custer, like ravenous wolves, and the end came quickly. Close by Custer's body lay the bodies of his two brothers Tom and Boston Custer, as also his nephew Artie

Reed, and the *N. Y. Herald's* reporter Kellogg. "Rain-in-the-Face" killed the two Custers, so Gall says; he cut Tom Custer's heart out and he says he ate it as he had taken a savage oath to do. Custer was next to the last man to die, only one remaining, and that was the pretty curly haired trumpeter. He would not surrender but kept up the fight, after the others were silent. He was found with his head near Custer's feet, and on his pallid face the slight trace of a smile.

The government intends and will no doubt in a few years, have a fine national cemetery here. They have moved to this spot the post cemetery of Fort McKinney, Wyo., and also the remains of the victims of the Fetterman massacre, which occurred in 1866, near Fort Phil Kearney, eighty-nine in number.

A neat little railway station is erected at Crow agency, Mont., which is only four miles from the battlefield.

This is the simple story of the battle as interpreted from the the solemn records. It was not a butchery but a battle—a mistaken one but nevertheless a battle, fought with intelligence on the part of Custer. Two-hundred and sixty-two rode with Custer. Two-hundred and sixty-two died, overwhelmed.

*J. M. Montgomery.*



SCENE OF LAST RALLY, CUSTER BATTLEFIELD, CROW AGENCY, MONTANA.

#### Sanitation in Burial.

Bacteriological science has freed the world from another boggy—to wit, the pestilential character of graveyards. It has long been imagined that the places in which human bodies were literally returned "earth to earth" were veritable breeding places of disease. The germs of the maladies that had caused the death of the bodies and innumerable other germs and poisons generated by the processes of decay were supposed to permeate the soil, to rise from it in noxious exhalations, and to contaminate the streams of water that might flow

near by. Great cemeteries were supposed to be a serious menace to the health of the cities, and one of the strongest arguments in favor of cremation has been that thus all these evils would be entirely abolished. Without entering into any controversy regarding the respective merits of incineration and inhumation, it may be said that this old notion of graveyards was ill-founded. *Nature* reports the results of a most careful and elaborate investigation of the subject which was recently made by Dr. Losener. In the experiments the actual conditions attending ordinary burial were adhered to



as faithfully as possible, both as regards the depth of the grave and the inclosure of the body. The duration of vitality of the various pathogenic bacteria vary considerably. Thus the microbes of cholera lived only twenty-eight days, and those of pneumonia a similar period. Typhoid bacilli, of which there has been an especial dread in connection with cemeteries, perished after 96 days of burial; and those of tuberculosis after from 95 to 123.

Tetanus bacilli are supposed to live and propagate indefinitely in the soil, and, indeed, after 264 days they were found in a highly virulent condition; but after 361 days they could no longer be detected. The germs of anthrax alone survived a year and more, and may be well reckoned the most persistent of all.

Attention was also paid to the possible spread of the germs through the adjacent soil and into streams of water. Generally speaking, they did not spread, or none of them but those of anthrax. The last named were found in the soil at some distance from the body, and also in the water.

None of the others were to be found, not even a few inches from the infected carcass. It, therefore, seems safe to conclude that burial is, in general, a sanitary method of disposing of dead bodies, and that cemeteries are not to be regarded as centers of infection or contagion. A field in which a host of cholera patients had been interred would in a month's time become perfectly fit for use as a garden or a pleasure ground. Of course, for other reasons, many people will prefer incineration. But this one oft-repeated argument against cemeteries may now be altogether dismissed. *New York Tribune.*

#### Adolph Strauch's Monument.

The Hon. John B. Peaslee, Cincinnati, O., has paid a warm tribute to the late Adolph Strauch, the landscape architect, in the *Cincinnati Enquirer*, for a copy of which we are indebted to Mr. Geo. Van Atta, superintendent Cedar Hill Cemetery, Newark. In the letter explaining the verses Mr. Peaslee related an interview with Mr. Strauch as follows:

"At that interview Mr. Strauch showed us the report of the French Commission appointed by the French Government to visit and examine the parks and cemeteries of the world, in which the commission declared that Spring Grove was the most beautiful of all cemeteries. This justifies the line: "The most beautiful of earth." Superintendent Strauch then requested me to write a magazine article on Spring Grove and his experiences when he began to remove the fences around the graves and otherwise to change, I should say, revolutionize the graveyard, in accordance with the "park plan," as he

called it, which was original with him. I agreed to do so. He then went on to say that when he began this important work, letters threatening his life were sent him, and that article after article appeared in the Cincinnati papers condemnatory of his course, that he had kept all these letters and newspapers and would look them up and turn them over to me for my use in preparing the article. This fully justifies the first verse of the second part of the poem. Finally having long felt that Adolph Strauch, who did so much to delight and refine our people and to improve our beloved city, should be held in the same grateful remembrance and be named in the same category with those great-souled personages who have given of their wealth to advance the interests of Cincinnati, I have classed him with them.

ADOLPH STRAUCH.

#### I.

Great genius of the West,  
By thy consummate art  
A graveyard, cold and drear,  
Was changed into a park.  
Spring Grove's thy monument,  
Most beautiful of earth,  
Thy mar'ulous talents gave  
Its wondrous beauty birth.  
Thou true to nature formed  
Its vistas, groups of trees,  
Its grottoes, knolls and dells,  
Bright streams and mimic seas.  
Park cemeteries are  
Original with thee,  
Where e'er their scen'ries charm,  
Thy monuments will be.  
Thy teacher Nature was,  
Thy implements, her trees,  
Her grass and vines and shrubs,  
All living plants that please.  
Thy work was not confined  
To "cities of the dead,"  
In other landscape scenes  
Thy master mind is read.  
Marks of thy skill abound  
In Eden's sylvan groves,  
On Clifton's leafy heights,  
Where'er the footman roves.

#### II.

The people of our land  
And hosts beyond the sea  
Owe debts of gratitude,  
Great nature's child to thee.  
Forsaken, cursed, despised,  
When thou, O Strauch, began  
To make an Eden fair  
This sepulchre of man.  
Thou'rt now enrolled upon  
Our city's honor banner,  
With Woodward, Hughes, McMicken,  
Springer, Sinton, Hanna,  
West, Longworth, Davidson,  
Probasco, Thoms and Brown,  
Goesbeck, Nichols, Schmidlapp,  
And others of renown.





LE REGRET. A CEMETERY MONUMENT BY MERCIE, PARIS.

#### A French Memorial.

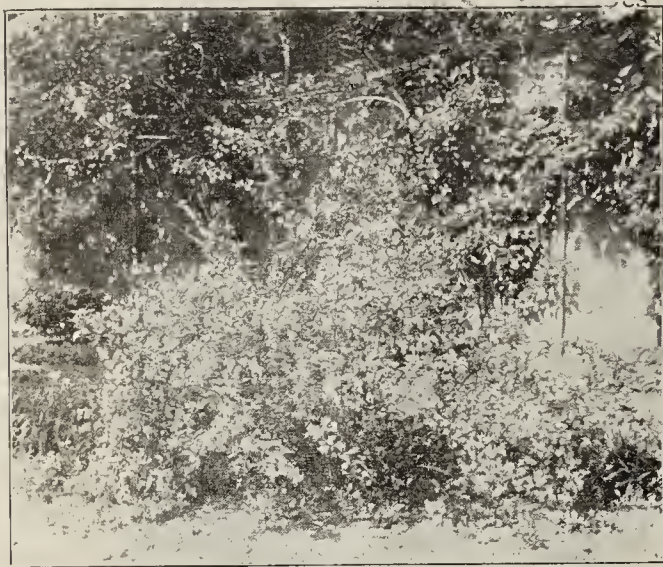
It is more common in foreign cemeteries than in our own to find occasional examples of high sculptural art, executed by sculptors whose names are famous. Such an example is illustrated above and is a memorial to some of the brave sons of France who fell in the Franco-Prussian war of 1870-71. The beautiful work needs neither description nor explanation. It speaks volumes and in every grace-

ful line may be seen the hand of a master, modeling a work in which he was in full sympathy. "Le Regret," translated into "Grief," is by the celebrated French sculptor, Mercie, by whom many well known works now adorning public places, have been executed. It is well that we should be enabled to study such memorials, for the sake of the new suggestions they offer and the instructive ideas which always cluster about works of the masters.



### Spring Flowering Trees and Shrubs.

"This world is but a fleeting show." If we never knew it before we know it now. Such a rush



WEIGELIA.

of flowers! They are scrambling through the season with almost indecorous haste. The spring flowering trees and shrubs have been crowded with bloom, and the successive species and varieties have crowded upon one another so closely as to materially shorten the flowering season. This, together with the unexpectedly early opening of spring, has made it almost impossible for a camerist to catch any given plant in its best form unless among them all of the time. And this difficulty has led to a renewed notice of the marked scarcity of well-grown cultivated shrubs and trees outside of Botanic Gardens, Parks and modern Cemeteries.

The flowering of all plants is this year not less than three weeks in advance of last year. This is due to the almost unprecedented warmth of early April, which, it was predicted, would surely be followed by disastrous frosts. So far however, they have not visited central nor southern Illinois, nor the corresponding parts of Missouri; and the flowery panorama that opened early in April has rolled on too rapidly to be thoroughly enjoyed.

In St. Louis, *Magnolia conspicua*, *M. Lennei* and even *M. Soulangeana* (which is expected to bloom later than the other two) were in full flower before

the middle of April. So also were many shrubs such as Japan Quinces and Forsythias in variety, *Spiraea Thunbergii*, flowering Almonds and Currants, etc. And these were closely followed by many others so that by the fifth of May Lilacs, white and red flowered Horse Chestnuts, White Fringe, Snow Balls, *Spiraea Reevesii* and others were past or fading; *Spiraea Van Houttei* approaching its best; *Crataegus Pyracantha* full of bloom, Coral Honeysuckle also and lovelier than it ever is later; Persian Yellow-Roses, a splendid mass of color; the charming little *Deutzia Gracilis* snowy with delicate flowers, and Weigelias in variety crowded with bloom. As grown in the Botanic Garden, Weigelias were a revelation. I didn't know they were so pretty. And the bees love them, they clustered thickly around each plant. Bush Cranberry, *Viburnum Opulus*, and *Calycanthus* were also in good flower; the former artistic in habit, with quite the air of a wildling, and decidedly ornamental with its numerous cymes of white flowers; and the spice bush fragrant with a perfume that is not found elsewhere, although seeming to combine several familiar odors.

*Rosa Multiflora* was full of its dear old-fashioned flowers, and in beds, *Agrippina* and *Hermosa* were already in bloom, while other Roses were rapidly preparing for their part in the show.

The Weigelia shown in the illustration is nearly white, of slender growth and drooping habit. It is one of many seen in the Botanic Garden; and part of a hedge of *Deutzia Gracilis* was also photographed there. The *Viburnum* or Bush Cranberry stood in Tower Grove Park which adjoins the



DEUTZIA GRACILIS.



garden. The big Snow-ball stands in my mother's garden in the village of Brighton, Ill., thirty-five



VIRBURNUM OPULUS. (High, or Bush Cranberry.)

miles north of St. Louis. It is an old plant; really a small tree some fifteen feet high, and is this spring a notable example of the necessity for carefully pruning flowering shrubs each year. For while the old wood was well covered with flowers, they were small; but all of the fresh, smooth, white wood not more than two or three years old, bore immense flowers, uniform in shape and size, and I found none less than six inches in diameter and deep in proportion. With proper pruning the plant might every year be composed of young wood. The tree was a beauty as it stood, as is shown to some extent, by the cut, but fancy it covered with such flowers as the large ones born this year in abundance on the newer canes.

But while cultivated flowering shrubs and trees are interesting, beautiful and indispensable, there is an indescribable charm about those of the wild-wood, and never have their blossoms been more abundant, more lovely or more fleeting than this year. Hundreds of Red Bud trees have tinged the cheeks of the woods with soft blushes. In many cases their drooping racemes fringed every branch so thickly as to show only a skeleton tree through the pink veil, the entire absence of foliage accentuating this effect. Plum blossoms whitened the thickets and sweetened the air, and clouds of delicious flowers clothed picturesque, scattering groups of wild Crab Apple trees. The nice effect of these natural colonies of wild crabs of various sizes, from tiny ones three feet high to old trees fifteen and twenty in height, and standing openly at irregular distances is a lesson in planting worth noting. Occasionally one stands alone at the border or on the

outskirts of a wood. One of these perhaps twenty-five feet in height, (the largest wild crab tree I recall seeing anywhere), was set from top to bottom with clusters of buds, mostly just ready to open, and not a flower in sight. The small, glowing carmine buds were like well set gems.

Wild cherries, always standing singly and usually isolated, bore masses of graceful racemes of small white flowers, and over on the river the common white Dogwood stood out distinctly against the cool, dusky depths of the ravines and clefts of the Mississippi bluffs.

Two beautiful Thorn trees are quite plentiful hereabouts; *Cratægus Nigra*, commonly known as Black Haw, and what is called here Red Haw, which is, I believe, common Hawthorn, *C. oxyacantha*.

The black thorns I have only found in moist bottom lands near living streams. It makes a handsome tree and one or two standing near the water were large—thirty-five or more feet high. Its deeply lobed leaves resemble those of the Mulberry, and its flowers are like pear blossoms in size, color, odor and the form of their clusters, but are placed much more effectively on the tree in that they face outward in all directions.

The Hawthorn or Red Haw is a little beauty. The best specimen found—and it was a picture—stood alone in a pasture, on quite a steep hillside facing northeast. A very dry and exposed situation. But the hills and trees at a distance of from thirty to fifty feet sheltered it on the west and



SNOWBALL.



southwest, and a tall shellbark Hickory afforded grateful shade in late afternoon. When I found it late one Saturday evening, it was enveloped in exquisite bridal flowers. But clearly it, too, was a part of the fleeting show, for when I returned on Monday to take its portrait in its snowy robe—nil! Everything was over, the flowers all fallen, and in the central depths of the thorny enclosure of the tree, a demure wood dove sat serenely on her frail but well guarded nest. It was such a dainty little tree, not more than ten feet high, perhaps eight in diameter, and clothed to within less than a foot of the ground with branches; and when wreathed throughout with delicate, snowy blossoms, it was too sweet to waste its sweetness alone in the old pasture, yet, could never be quite so charming any where else. To bring away its picture would not have harmed it and I regret that I failed to do so. For the evanescent charm of wood and meadow is subtle. And while glimpses of shadowy perspectives, of fence corners overflowing with fascinating tangles and roadway borders powdered with wild blackberry blossoms; with here the clear note of a meadow lark and there a quaker-like quail walking with well assumed composure, directly away from her hidden nest; and at the turn of the lane a warm breath of spring, sweet with the odor of flowering grapes, that makes time stand still while memory recalls scenes and faces of other days, are all very real when one is present in the flesh—a mere account of them may seem vainer than the vanities of the fleeting show.

*Fanny Copley Seavey.*

#### Essential Features of the Park.\*

“We have always used the word (park) to indicate primarily a place where the mind and body are refreshed by rural scenery. Of course, a park will also furnish fresh air and sunshine, opportunities for bodily exercise and rest, but beyond these, and more important than these, is the refreshment of mind which comes from the influence of beautiful natural scenery. The paths and roads are not, therefore, merely places to walk in or drive over; their fundamental use is to make the scenery of the park available to persons on foot or in carriages or on horseback, so that they may find that relief and repose which natural beauty alone can bring to city-wearied senses. The value of a city park, therefore, for a city population, is greater or less according as the poetic charm of its scenery is preserved and developed.”

\* \* \*

“No urban park is safe until public sentiment is educated up to a controlling belief that breathing

space in a city is quite as essential to the mental, moral and physical health of its people as building space, and that the very best use to which a certain portion of its territory can be put, is to cover it with greensward and keep buildings off of it.”

\* \* \*

“Sound art, high art, in our spacious city parks means essentially the development of every possible poetic charm in their natural scenery and the exclusion of every element which conflicts with this purpose.”

“It seems to be an admitted fact also that quiet pastoral prospects have the greatest intrinsic value in enabling us to resist the wearing influence of city life and recover wasted mental energy, and it therefore follows, that the best work is not one in which the architectural features predominate, or in which the planting aims to be highly ornamental or decorative.”

“Not only is beauty essential to a park; its whole value lies in beauty. But it must be that serene and enduring beauty which is embodied in its essential and permanent features, and not merely the transient and superficial beauty of floral embroidery. It must have dignity of expression, and not mere prettiness.”—*Garden and Forest.*

“A landscape park requires more than most works of men, continuity of management. Its perfecting is a slow process. Its directors must thoroughly apprehend the fact that the beauty of its landscape is all that justifies the existence of a large public open space in the midst, or even on the immediate borders of a town, and they must see to it that each newly-appointed member of the governing body shall be grounded in this truth. Holding to the supreme value of fine scenery, they will take pains to subordinate every necessary construction, and to perfect the essence of the park, which is its landscape, before elaborating details or accessories.”

\* \* \*

“The type of scenery to be preserved or created ought to be that which is developed naturally from the local circumstances of each case. Rocky or steep slopes suggest tangled thickets or forests. Smooth hollows of good soil hint at open or “park-like” scenery. Swamps and an abundant water-supply suggest ponds, pools or lagoons. If distant views or regions outside the park are likely to be permanently attractive, the beauty thereof may be enhanced by supplying stronger foregrounds; and, conversely, all ugly or town-like surroundings ought, if possible, to be ‘planted out’.”

\* \* \*

“Large public buildings, such as museums, concert halls, schools and the like, may best find

\*Extracts from a pamphlet issued by O. C. Simonds, Landscape Architect, Chicago, Ill., discussing the Lake Front Park of that city.



place in town streets or squares. They may wisely, perhaps, be placed near, or facing upon, the park; but to place them within it is simply to defeat the highest service which the park can render the community. Large and conspicuous buildings, as well as statues and other monuments, are completely subversive of that rural quality of landscape the presentation and preservation of which is the one justifying purpose of the undertaking by a town of a large public park."

"Most men of specialized training, such as architects, engineers and all grades of horticulturists, stand in need of an awakening before they are really competent to have to do with park work. Each has to learn that his building, his bridge or road, his tree or flower, which he has been accustomed to think of as an end in itself, is, in the park, only a means auxiliary and contributive to a larger end—namely, the general landscape."

"In spite of a common popular prejudice to the contrary, it will generally be found that concave, rather than convex, portions of the earth's surface are to be preferred for park sites."—*Frederick Law Olmsted*.

"The element of interest which, beyond question, should be placed first, if possible, in the park of any great city is that of an antithesis to its bustling, paved, rectangular, walled-in streets—a requirement best met by a large meadowy ground of an open, free, tranquil character."—*Olmsted & Vaux*.

#### The English Oak.

The reference to the English Oak in a recent number of PARK AND CEMETERY, leads me to write of some that I saw in England last summer, and the accompanying illustration shows one growing in the ground of Appley Tower, near Ryde, Isle of Wight. It is true, as the writer says, that in this country this oak does not change the color of its foliage at all, but retains its green hue until the very last. All the European oaks do this, notably the Hungarian and the Turkey, as well as the common English. As so many of our native sorts change so beautifully, it is thought rather in favor of the English that it does not change, as its bright green makes a pleasing contrast. And in just the same way many value the Norway Maple, as it behaves in a similar manner.

The English oak is quite a feature in the English landscape, and can always be recognized by the round-headed growth it makes. The illustration well represents them as usually seen. The whole of the Isle of Wight, excepting the cliff portion and the downs, as the elevations on it are called, is well

covered with this oak. Their wide spreading limbs afford shade for large numbers of persons under one tree; and in the winter season pigeons eagerly



ENGLISH OAK.

seek the acorns. These trees are long lived, of slow growth and get to be very large. The dimensions of the one illustrated, I took myself and found it to be as follows: The circumference of trunk 21 feet; the spread of the branches 100 feet. And this grand tree appeared good for as many more years as it had already seen, so vigorous did it seem in every way. The owner of the grounds, Mr. Hutt, who kindly had the photograph taken for me, speaking of the oak for forestry purposes, remarked that it could be allowed to grow 200 years without its having passed the time for its best cutting. In the same connection he said the sweet chestnut might be given 60 years and the ash 100 years.

In all public parks that I visited, the English oak had been given much prominence. There are so many of them of large size to be seen everywhere, that it has misled many casual observers into believing that all the trees of England are round-headed and spreading, but this is not the case. There are gigantic horse chesnuts at Bushey Park and ponderous elms at Richmond Park, which are not of this character, the elms, particularly, were as tall as trees get to be here; and for massiveness I never saw their equals.

Referring again to the oaks on the Isle of Wight, a useful lesson is taught by their appearance there. I have often heard it said here that trees cannot be made to thrive in the vicinity of the sea, and I have as often combated the assertion. This island is surrounded by the waters of the English channel and if a place on earth can be found showing more thrifty trees and verdant fields, I do not know of it. The fact is planters need not have any fear of salt air. Salt spray may be injurious in some cases,



but even this is not harmful in moderation in the case of some trees. The injury is from fierce winds, tearing and bruising the foliage; and this leads to the mention of the remedy, viz, to massing of trees at points where strong winds are to be feared. Banks of pines are good on the outskirts, as their needles are not so prone to injury then, deciduous trees on the sheltered side of them. With such protection any hardy plants may be set near the sea.

Joseph Meehan.

Ambassador Eustis was present at the unveiling of a memorial tablet that has been erected on the site of the villa at Passy occupied by Benjamin Franklin from 1777 to 1785. It was at this villa that Franklin erected his first lightning conductor. The dramatist, M. Manuel, president of the Passy Historical Society, presented the tablet. M. Faye, a member of the French Academy, spoke of Franklin's scientific researches. It really looks as though the recognition by France of Benjamin Franklin has stimulated his fellow countrymen into renewed energy to fittingly commemorate his services.

**Garden Plants,—Their Geography. VII.**

CARYOPHYLLALES.

THE DIANTHUS, PORTULACA, AND TAMARIX ALLIANCE.

*Silene* has 250 species with numerous varieties distributed over the temperate regions of Europe, Asia, Africa and N. America. We have two or



SILENE PENDULA  
(Nana Compacta.)



SILENE PENDULA  
(Double.)

three native to the Atlantic states, *S. Pennsylvanica* being one of the commonest, and five or six European ones are adventive. They are pretty plants often found in gardens.

*Silene compacta* and *S. Schafta* from Asiatic Russia are useful kinds. Great Britain has eleven species some of which are admitted to gardens. They make a fine display in masses during May and June, and such as *S. maritima* as late as July, or *S. Schafta* as late as September.

*Lychnis* has forty species confined to the tem-

perate parts of the Northern Hemisphere. A dozen species are found in the United States some of which are naturalized. The rare little Scotch *L. alpina*, found there



LYCHNIS,  
HYBRID.



LYCHNIS COELI.  
Rosea.

only in Glen Isla and the Glova mountains flowers in our gardens in May, it is not very showy. *L. Chalcedonica* and its varieties flower in June as do some others. Quite a number flower at midsummer, and *L. alba* (*vespertina*) fl. pl. in Aug.—Sep.

*Cerastium* has 45 species and twice as many names. They are found all over the world. Some are used in gardens as flowering or foliage plants.



CERASTIUM TOMENTOSUM

*Stellaria* "stichworts," have eighty-five species of wide distribution, a few are useful as rock plants, and for edges of beds or borders.

*Arenaria*, "Sandworts,"

have a still larger representation of 160 species and are quite ubiquitous. Some are useful plants for rock work. *A. ciliata* which is rather pretty is the rare Irish species, having been found there only in the vicinity of Ben Bulbin, County Sligo. The genus, large as it is, appears to have been absorbed and distributed into other genera (as far as names go) by some American Botanists.

*Sagina* in eight or ten species of low growing weeds are of wide distribution in the Northern Hemisphere. *S. procumbens* is British, one quarter of an inch high, and covered in early summer with little white flowers. The golden variety of *S. pilifera* is also used in Europe.



*Spergula*, "spurry", in two or three species are plants of wide distribution. *S. pilifera* (Sagina now) attracted wide attention some years ago as a substitute for lawn grass, and although it dies out in places and becomes patchy, yet it is useful for grave mounds and similar positions where mowing is troublesome. Seed may be sown, or the plants divided and set three inches or so apart. It should be beaten with the spade to keep it compact, and of course wet. *S. arvensis* is naturalized in the Atlantic States.

*Portulaca*, "Purslane," has twenty species widely distributed over the warmer parts of the world.



PORTULACA GRANDIFLORA, FL. PL.

They are mostly annual herbs. *P. grandiflora* and its double varieties are well known, and sometimes become wild.

*Claytonia*, "Spring beauty," has 10 species distributed over North America, North Asia and New Zealand.

*C. Virginica* is usually found in moist woods, it is a beautiful little plant with pink flowers.

*Lewisia* in two species are natives.

*Tamarix* has perhaps not more than twenty-five species distributed over the warm temperate parts of Northern Europe and Asia, and in South Africa. They are difficult to determine and identify. We appear to have three or four species in gardens flowering at different times. *T. Gallica* is the British kind, famous as a seaside shrub. They become trees under favorable conditions. The largest I have seen in the United States is on the Perrine properties at Trenton, N. J. It is quite thirty feet high, with a circumference of trunk of 3 feet 6 inches at the ground, and 2 feet 8 inches at a height of 3 feet. It has been supposed to be *T. tetrandra* from its flowering in July, but this is at least open to doubt. The tree has suffered during the last three winters.

*Myricaria* is a genus of four species from Europe, Asia and the Himalayan regions, and is made to include *tamarix dahurica*, *T. Germanica*, etc., which are found (by the microscope) to be generically distinct.

*Hololachne* is a monotypic Central Asian genus of which I fail to find any account, and it is probably not in gardens.

*Reaumuria* from the Island of Sicily eastwards through the Eastern Mediterranean regions to Central Asia, has twelve species of shrubby, evergreen

plants with pink and purplish flowers. They are somewhat tender so far as known and tried in the south of England, but there can be little doubt that the Central Asian species would prove hardy in parts of this country.

*Fouquieria* has three species but they are not hardy at the North. They extend from Mexico and are found within the United States.

Trenton, N. J. *James MacPherson.*

#### Legal.

##### LIMIT TO NOTICE GIVEN BY GRAVE.

A grave, even it be protected by a fence around it, if located in a burial place, though such place is used only to a limited extent for general burial purposes, the supreme court of Illinois holds does not indicate or give notice of an appropriation or possession of more of the land than is within the inclosure.

##### RIGHTS IN BURIAL PLACES.

An important addition to the meagre legal literature on this subject is made by the supreme court of Alabama in a recent decision,

It seems to be very generally agreed, says the court, that a dead body is not the subject of property right, and becomes, after burial, a part of the ground to which it has been committed.

When one buries his dead in soil to which he has the title, or to the possession of which he is entitled, there is no difficulty in his protecting from injury and insult by an action of trespass against a wrongdoer.

But, bodies are most commonly interred in public cemeteries, where the parties whose duty it is to give them burial, are not the owners of the soil by deed properly executed, and have no higher right, than a mere easement or license. Of such it is held, that they do so under a license, and their exclusive right to make such interments in a particular lot, would be limited to the time during which the ground continued to be used for burial purposes; and upon its ceasing to be so used, all they could claim would be, that they should have due notice and an opportunity to remove the bodies to some other place of their own selection, if they so desire, or on failure to do so that the remains should be decently removed by others.

Where one is permitted to bury his dead in a public cemetery, by the express or implied consent of those in proper control of it, he acquires such a possession in the spot of ground in which the bodies are buried, as will entitle him to maintain an action against the owners of the soil or strangers, who, without his consent, negligently or wantonly disturb it. This right of possession will continue as long as the cemetery continues to be used; but if,



for proper and legal reasons it should be discontinued and the license withdrawn, and the bodies of the dead are to be removed, it must be done decently, only after due notice to the party entitled, if known, and such notice can be given.

\$1,700 is, however, too much to be allowed for damages, the court thinks, for moving the body of a child from one cemetery to another, on account of the discontinuation of the former as such, without notice first having been given to the parent to remove it.

#### Rules for Receiving Trust Funds.

The following are the rules for the receiving of trust funds by the Lowell Cemetery Corporation, Lowell, Mass:

1. That the treasurer be authorized to receive, and give the depositor thereof a receipt for any sum of money that may be deposited with the trustees of this corporation for the care of any particular lot, to be expended in the manner directed by the proprietors of the same, the lots to be credited with the amount and debited whenever an expenditure is made.

2. That when the sum so received be fifty dollars or more, it shall be deposited with the other trust funds in some one or more of the institutions for savings in the city of Lowell, or loaned to some city or town in the County of Middlesex, preference being always given to the city of Lowell, and the income thereof be annually credited to the lot.

3. That all moneys received for the purpose above expressed shall be kept and managed as one fund—the income thereof to be divided annually and carried proportionally to the credit of each lot entitled thereto.

4. That the treasurer be required to report at every annual meeting of the corporation the names of all persons who shall have made such deposits, the outlay made on the respective lots for the year then expired, and the balance then standing to the credit of the same.

5. Owners of lots can secure the perpetual care thereof by the payment of the sum designated by the corporation, the amount being decided by the size of the lot.

6. In no case will a trust fund for perpetual care be accepted until the lot is put in condition as satisfactory to the superintendent.

7. The Trust Fund regulations shall in all cases be assented to by the person making application before deposit is received.

The legislature of Massachusetts has authorized the expenditure of \$1,500,000 by the metropolitan park commission, Boston. Two bills were acted upon, one for a \$1,000,000 loan, under which the great Charles River Park, in Newton, is expect-

ed to be laid out, the other \$1,000,000 was for the specific "construction of roadways and boulevards." This was cut down to \$500,000 on the argument that while park reservations are for the advantage of the whole community, the boulevards are for the immediate community.

\* \* \*

To get rid of weeds, says the *Minnesota Horticulturist*, they must first be prevented ripening their seed, and then the plant itself must be eradicated. Where it is possible, they should be pulled; if small, keeping them cut off will eventually kill them.

## Correspondence.

Mr. Asa R. Taber, secretary and superintendent Maplewood Cemetery, Springville, N. Y., reports an excellent plan for assisting lot owners to decide upon locations of graves on their lots when interments are to be made. The lots in the cemetery are nearly uniform—10' x 20', 20' x 20' and 20' x 24'; some are circular. Rubber stamp diagrams are made of the several sizes, which are subdivided into divisions of one square foot by dots. These he uses in the record book, and also when a party calls at the office to have a grave opened, a stamped diagram of the lots is handed to him to take to the family or friends, so that a location can be decided upon and the diagram returned to the office for the sextons use. These rubber diagrams are found to be very useful in many ways, for instance in locating monuments.

#### Drainage.

In a preceding number were sketched a few principles which the writer considered of unusual application to all parks and cemeteries. Briefly summarized they were: Good order, constant and complete repair, active fertility, scrupulous cleanliness, and general thrift. All these may be safely assumed as recognized elements of worthy attention. Intimately allied to the carrying out of these principles, and in most all localities will be found needful and useful some system of under drainage for the wet season, and an available means for irrigation when the usual heat and drouth appear. This under drainage and irrigation may often with great advantage be made to supplement each other; so that water collected in March, April and May, shall supply a want often seriously felt in June, July and August. Deep under drainage will often be found capable of redeeming for use large areas, otherwise regarded quite unfit for use as interment ground; and again the very low lying areas may be made far better as lawns and plantations,—the drainage giving both fertilization and quality to vegetation. Drainage will generally and indeed can always be made to play an important part towards making and maintaining good drives; the important effect and influence on the landscape will come through the underlying principle of action and may prove too subtle for the observer to comprehend whence the benefit arises. Drainage has often proven an expensive failure and therefore deserves very careful consideration. An advance plan should be matured taking full account of the aim and end from the beginning to the final purpose sought or hoped for. Where irrigation depends upon the collections made by drainage, the scheme at once contemplates a pond or reservoir of large capacity, constructed on the low grounds, where the water can be retained until needed for irrigation. Also a pump of suitable capacity, an elevated tank and pipes to convey by gravity wherever needed. These are the suggestions, the details need no attempt at discussion here, but cemetery and park boards can take them up for consideration, and the writer feels confident that much that is practicable and useful can be carried forward and attained.

B. F. H.



## PARK NOTES.

The yearly cost of maintaining the parks under the control of the London County Council is nearly \$500,000.

\* \* \*

Another national park, ten miles square, has been purchased under treaty with the Shoshone and Arapahoe Indians, from their reservation in Wyoming. The tract is located on the head waters of the Big Horn river in the Owl mountains. It is a rough but picturesque region and contains a famous hot spring. The Indians are to be paid \$60,000 in five annual installments.

\* \* \*

It is quite possible to arrange flowers in a garden so that a clock is unnecessary in order to tell the time. In the days of Pliny, forty six flowers were known to open and shut at certain hours of the day and this number has been increased since then. For instance, dandelions open promptly, often to the minute, at 5:30 in the morning and close at 8:30 at night. The common hawkweed opens at 8 in the morning and may be depended on to shut at a few minutes to 2. The yellow goats-beard shuts precisely at noon, sidereal time. The white lily opens at 7 a. m. and closes at 5 p. m.

\* \* \*

The formal gardening so much in vogue in the principal Chicago parks is in large measure to give way this season to the natural idea. Visitors to the park flower gardens this year will look in vain for the "Gates Ajar," the "Liberty Bell," the "Canoe" and other such evidences of mechanical gardening, and in their place will find masses of flowering and foliage plants arrayed to harmonize and display their characteristic features and beauty. To numbers of people formal gardening has its fascination, but gardening arrayed on the lines of nature's wondrous methods has a permanent value, improving with time.

\* \* \*

It is gratifying to note that the subject of forestry is rapidly attracting the attention it demands and which is accorded to it by other civilized nations. It is considered a most important part of the course of study at the schools of agriculture, St. Anthony Park, Minnesota, under Prof. S. B. Green. Its study familiarizes the students with the habits and value of our common native trees as well as those introduced for special economic reasons. The characteristics of the trees are studied, their adaptability to circumstances and locations, their habits of growth, hardiness, and value for specific purposes and the methods of distinguishing and propagating them. These and other considerations pertaining to the conditions and requirements of various locations, are investigated, as well as keeping up the supply for useful purposes. The students are required to study the trees themselves in the nursery, the forest plantation and on the grounds of the experiment station, and also to make several excursions to nurseries and plantings in the vicinity of the school.

\* \* \*

The government reservations of public lands as public parks already comprise a large acreage, but as the result of such reservations are obviously for good and have been generally approved, the government should go further and properly police, protect and where beneficial, improve them. The large areas so far established with the acreage are as follows: In Wyoming: Yellowstone Park Reservation, 1,239,400 acres. In Colorado: White River Plateau Reservation, 1,198,080 acres; Plum Creek Timber Reservation, 179,200 acres; Pike's Peak Timber Reservation, 184,320 acres; South Platte Forest Reservation, 683,520 acres; Battlement Mesa Reservation, 858,240 acres. In New Mexico: Pecos River Forest Reservation, 311,040 acres. In Oregon: Bull Run Timber Reservation, 142,080. In Alaska: Afognak

Forest and Fish Reserve. In California: San Gabriel Timber Reserve, 555,520 acres; Sierra Forest Reserve, 4,096,000 acres; San Bernardino Forest Reservation, 737,280 acres; Trabuco Canyon Forest Reservation, 49,920 acres. In Arizona: Grand Canyon Forest Reserve, 1,851,520 acres. In Washington: Pacific Forest Reserve, 967,680 acres. Oregon: Cascade Range Reserve, 4,492,800 acres; Ashland Forest Reserve, 343,073 acres.

\* \* \*

Quincy, Ill., is just waking up to the importance of a well planned park system; but it has taken some ten years to get the system fairly inaugurated. Mr. E. J. Parker, president of the Quincy Boulevard and Park Association has just presented his report to the annual meeting. According to this document the city has done comparatively little towards the development of its 70 acres of park proper, and the work accomplished has been mainly that of the association above named, a fact highly creditable to the forethought and public spirit of certain of its citizens. The area of its parks, including the public squares is 70.06 acres; the amount due on deferred payments and expended by the association is in all \$50,017.50. The total receipts by the association from all sources is \$16,517.92, of which the town of Quincy takes credit for \$9,824.09. The only special tax for park was a one mill tax amounting to \$4,888 80. For a town of 40,000 inhabitants this is not a liberal showing as far as the city is concerned. Some very valuable suggestions are made in Mr. Parker's report which it would be well for his fellow citizens to entertain.

\* \* \*

The State Board of Forestry Commissioners of New Hampshire, have begun the actual work of preserving the forests of the White Mountain region for the use of the public as a forest preserve in the ownership and under the care of the state. The law under which the commission acts is under section 4 of the Forestry law of 1893, which provided that "whenever any person shall supply the necessary funds therefore, so that no cost or expense shall accrue to the state, the Forestry Commission is authorized to buy any tract of land and devote the same to the purpose of a public park." If they cannot come to an agreement on price with the owners, the land can be condemned under the law of eminent domain. The persons furnishing the money to buy such lands may lay out roads and paths, and otherwise improve it under the directions of the Forestry Commission, but it shall be at all times open to public use. The work will begin in the very heart of the White Mountains and be extended to other points as fast as practicable. Several large contributions have been received, but the general cooperation of the public is desired and no contributions need be withheld.

\* \* \*

Omaha is enjoying some litigation over Prospect Hill Cemetery. This, the old cemetery of Omaha, situated about two miles from the post office, contains some 16 acres and occupies a beautiful hill overlooking the town and the Missouri river. It was owned by Byron Reed who also owned the adjoining property on three sides. In 1885 the city had surrounded the tract and gone two miles beyond. At this time Mr. Reed concluded that it would have to be removed, and together with other business men incorporated the Forest Lawn Cemetery Association, purchasing a large acreage adjoining the city limits, and deeded all his interest in Prospect Hill Cemetery to this association, conditional upon its use for one year until the new tract was ready. What there was left vacant of Prospect Hill was to go to the city of Omaha, for park purposes, he intending to turn the whole place into a park eventually. But Byron Reed died and the Prospect Hill lot owners formed an association to continue the cemetery and extend it for revenue. The adjacent property owners objected and have succeeded in securing an injunction which has been sustained in both the County and District Courts.



## CEMETERY NOTES.

The annual report of Calvary Cemetery, St. Louis, Mo. shows the number of lots sold during past year to be 287 and the number of interments 2481. The total number of lots sold up to April 1, 1896 has been 9815, and the total number of interments to same date 58,224. Among recent improvements is a half mile of new roadway constructed this spring. During the past year there were 356 foundations laid for 126 monuments, 133 headstones and 97 entrances.

\* \* \*

At the annual meeting of the lot holders of Magnolia Cemetery Charleston, S. C., Mr. George W. Williams, chairman board of trustees, reported that the permanent fund now amounted to \$35,564.57, an increase for the past year of \$1,567.57. The perpetual care fund for the care of lots now amounts to \$24,216.50 and is quite rapidly increasing, and special attention is urged upon the lot holders to contribute to this end. Since the cemetery was opened in 1850, 2,250 lots have been sold and nearly 10,000 interments made. Great improvement has been made in Magnolia Cemetery on progressive lines, and it is now in good condition and carefully looked after.

\* \* \*

The Chinese of New York, Brooklyn and contiguous territory, have a burial plot in Cypress Hills Cemetery, Brooklyn, where some 200 bodies are temporarily interred with their feet toward the Polar Star. Periodically some of the bones are exhumed and shipped to China to be reinterred with those of their ancestors. A little plot, oblong in shape, occupying some 500 square feet of ground is inclosed by a railing of iron bars, supported by short pillars of white marble. It is the only burial grounds of its kind in that section of the country. It is used not as a permanent abiding place for the bodies of dead Celestials, but as a temporary place of interment. It is the custom of the Chinese to exhume the bodies of their dead five years after the date of burial. The bones are then scraped and placed in a casket of bronze and silver. Silk and other costly fabrics are wrapped around the remains, and then the casket is sealed. It is shipped and laid away beneath the soil of China. A Mongolian would spend his days in misery if he thought his remains would not be buried in the land of his nativity, and it is remarkable what sacrifices he will make to insure this end. The rites attending the exhuming of the remains afford considerable interest to the American citizen.

\* \* \*

A number of bodies have been disposed of in Oakwood Cemetery, Niagara Falls, under a new method of burial called cementation in which two processes are practiced: One by imbedding the coffin in cement, the other by pouring the cement around the nude body. When the first method is used it is necessary to prepare the body with antiseptics, in order to preserve it thoroughly. This is the more common practice. Judge Hulett describes the system as practiced at Oakwood as follows: The grave is made of the usual depth and 16 inches larger than the rough box that is to contain the coffin. A concrete mortar is then prepared of fresh water-lime, cement, sand and fine broken stone, the proportions of which are one part cement to three of sand and broken stone. This mixture is put in the bottom of the excavation to the thickness of about eight inches; the rough box is laid upon this cement so as to leave a space of about eight inches on all sides between the earth and the box. The concrete is poured into the space around the box. It is well stirred with a wooden point, so as to make it of an even consistency. This part of the work may be done the day before

the burial. After the coffin has been lowered into the box a lid is screwed on to the latter, and then a coat of cement eight inches thick is laid on the lid. Care must be taken that this cement unites perfectly with that surrounding the sides of the box. When the top coat of cement is hardened the name of the deceased and any other words may be carved on it. These will last almost forever.

\* \* \*

At this season of the year, and especially on account of the unprecedentedly early and hot spring in many localities of the country, great care and much labor must be expended to preserve the lawns and grass plats of the cemetery, otherwise a parched and burned appearance will characterize them. Where an abundant water supply exists, the situation can be readily met; where poor water facilities make it difficult to keep the place fresh and green, the weeds should be kept down and the grass cut, so that the dismal appearance of the average country graveyard in a dry spell may be as far as possible obviated, and the devastating and unsightly effect of the frequent fires occurring in those located near the railroad be altogether averted. The spring is the time to clear up and trim, and the country cemetery can, with some energy and care, be made to blossom as a rose, notwithstanding that conditions are perhaps not so favorable as elsewhere. Organize the village improvement society and let the cemeteries be one of the first things cared for, it will repay the forethought a hundredfold in promoting increased interest.

\* \* \*

Mr. Chas. L. Knapp, treasurer of the Lowell Cemetery, Lowell, Mass., makes the following pertinent remarks on the amount which should be funded for the care of lots: While believing in the policy and wisdom of providing for perpetual care, I think that too often insufficient money is deposited. In a majority of cases a person deposits \$100; this with a view of providing the usual \$4.00 annual care charge. This is well and good so long as existing circumstances prevail. But there is no margin. Accidents will happen to stone work. The rate of interest might become less than is paid by our saving banks to-day. Several circumstances might arise, when the income which barely provides the needs of to-day, would be insufficient. We do not wish to create uneasiness in the minds of any one, but is it not reasonable to allow some margin for future contingencies? In my opinion \$150 is little enough deposit for an ordinary lot, for a principal, especially in view of what a majority of lot owners expect to receive in return and that for all future time. During the past winter, a piece of marble work, improperly set originally, was blown over by the wind and so damaged that in the opinion of the marble worker it was useless to reset. An ample trust fund that had accumulated interest, permitted the corporation ordering new work, which was done. We may say also, that in this case, all interested in this lot in question are buried therein, and illustrates the wisdom of the perpetual care process. Had the lot in question been trust funded to the extent of bare annual care charge, we could not repair the damage, obviously. The fifty-fourth annual report of the business of the Lowell cemetery to the proprietors has just been issued, dating from February 1, 1895 to February 1, 1896. Both the reserve fund and the trust fund have steadily increased. The perpetual care principal, in twelve years has grown from \$13,990.45 to \$67,343.39, having increased \$4,630 during the past year. Lowell cemetery has suffered from the depressed times, the sale of lots last year amounting to only \$3,186.93, which with the exception of 1889 is the smallest sales for ten years. The total receipts from all sources were \$36,562.07. At the meeting Mr. Robert H. Mulno was unanimously reelected superintendent, entering upon his twentieth year of service for the corporation.



### Association of American Cemetery Superintendents.

O. C. SIMONDS, "Graceland,"  
Chicago, President  
G. W. CREESY, "Harmony Grove,"  
Salem, Mass., Vice-President.  
F. EURICH, Woodlawn, Toledo, O.,  
Secretary and Treasurer.

The Tenth Annual Convention will be held at St. Louis, September, 15, 16 and 17.

### Publisher's Department.

NOTICE TO SUBSCRIBERS. If this notice is marked with a blue pencil it indicates that your subscription to PARK AND CEMETERY has expired and a renewal of same is solicited.

Park Commissioners and Cemetery trustees are requested to send us copies of their reports.

Photographs and descriptive sketches of interesting features in parks and cemeteries are solicited from our readers.

PARK AND CEMETERY wants the names of every park and cemetery official or employee who would be likely to be interested in this paper. To the many subscribers who have sent in such lists of names, we return our thanks. There are many more that we should hear from.

Subscribers are again reminded that we want brief notes on any feature of park or cemetery work that will be of general interest. PARK AND CEMETERY is the only publication of its class and earnestly solicits the co-operation of subscribers in making it a help to all indentified with such work.

### Association of American Cemetery Superintendents.

Preparations are being made for the tenth annual convention which will be held in St. Louis, Mo., Sept. 15, 16 and 17 of this year. Arrangements have been perfected to hold convention at the Planter's Hotel, where members will be accommodated at rates from \$3.00 per day and upwards. The Executive Committee would be glad to receive suggestions that will help make up the programme. Communications may be addressed to Chairman M. P. Brazill, Supt. Calvary Cemetery, St. Louis, Mo., or Secretary Frank Eurich. As arrangements progress announcements will be made in these columns.

*Frank Eurich,*  
*Sec'y and Treas.*

Sta. "B." Toledo, O.

The annual meeting of the executive committee of the Society of American

Florists was held at Cleveland, O., April 28-30. Preparations for the August convention were discussed. Among the important subjects for discussion at the convention will be: The Chemistry of Fertilizers, "Commerical Law as applied to our Business," and "Over production as viewed from the standpoint of Producer, Wholesaler and Retailer."

The annual meeting of the American Association of Nurserymen will be held at the Sherman House, Chicago, June 10 and 11. Special efforts have been made to make this a profitable meeting from a business stand point.

Mr. Bellett Lawson, Chicago, has just completed laying out a new cemetery on the lawn plan at Barry, Ill., and is now employed on similar work at Des Moines, Iowa.

### Andrew S. Fuller.

One of the brightest lights of the horticultural world went out, when Andrew S. Fuller departed this life at his beautiful home, Ridgewood, N. J., on May 4. Born in Utica N. Y., in 1828, he began his career as a florist in Milwaukee, at the age of 18, and for more than 40 years he has since been prominently before the public as a writer on horticultural subjects. In many respects he was a remarkable man, well and favorably known to a vast number by his valuable writings; a man of scientific leanings, exact and painstaking in his experiments and investigations, and an enthusiast in nature's methods and works. To say that he was a public benefactor is to accord to men of his attainments and disposition the word of commendation which the record of such lives sustains. He was laid to rest in his own beautiful grounds at Ridgewood.

In the note on Kensico Cemetery, New York, in our last issue it was inadvertently stated, that the cemetery was organized in 1874. It should have been 1891. The organization was effected in that year and work immediately commenced, the first interment being made almost at the same time. This year's business shows a very large increase.

### Received.

By Laws, Rules and Regulations of Oakgrove Cemetery, Delaware, O.

Rural Cemeteries. Folder by Frank H. Nutter, landscape architect, Minneapolis, Minn.

Our City's Breathing Places; remarks before All Souls Unity Club, Grand Rapids, Mich., April 8, 1896. By Chas. W. Garfield.

The fifty-fourth annual report of the business of the Lowell cemetery to the proprietors, 1896. Attached to this report which is distributed to lot owners is a blank order, so perforated as to be readily detachable from the page. This order is addressed to the superintendent, and under certain heads authorizes him to do certain work upon their lots during the current year at prices fixed by trustees, to the extent of the amount named on order. This is signed by lot-owners, with address to which bill should be sent. This is an excellent feature. It is not only suggestive to the lot owner, but when attended to settles the matter for the year and ensures proper attention at proper times.

Cemetery officials and plot owners will be interested in the Memorial Restorer referred to on page 268.

### Roads.

There is no more important department of park and cemetery work than that of making and maintaining good roads, and good roads are now more quickly brought into condition than in former days, by reason of the machinery constructed for the different parts of the work. And besides, the improvements in road making machinery have been effected far in advance, as it were, of the development of good roads over our country. These remarks have been suggested by a perusal of the catalogue of the American Road Machine Co., Kennett Square, Penna., whose profusely illustrated and descriptive catalogue of road machinery is a revelation of what is now constructed in this way for that class of public works. This is the eighteenth annual catalogue of the company and fully explains and describes the general and special merits of their complete line of Road Graders, Rock Crushers, Road Rollers, Engines, Distributing Carts, Wheel Scrapers, Drag Scrapers and Road Plows. The catalogue is most complete in its illustrative and descriptive matter and can be obtained by readers of PARK AND CEMETERY interested or likely to require such machinery.

E. T. Barnum, the Detroit, Mich., manufacturer of wire and light iron work is mailing to the trade all over the country their annual spring catalogue, which is just issued. Besides this general catalogue they are issuing a number of others, each devoted to a special class of work, such as: "Builder's Iron, Wire and Brass Goods;" "Fencing;" "Jail Cells and Jail Work;" "Bank and Office Railings, Panels, Guards, etc." Any of our readers likely to require work in any of these lines can secure a catalogue by writing and specifying the kind of work wanted.



THE SUPERINTENDENTS LIBRARY.

**Landscape Gardening**, by Samuel Parsons Jr, Supt. of Parks, New York City. Notes and suggestions on Lawns and Lawn Planting. Laying out and arrangement of Parks, etc. Deciduous and Evergreen trees, shrubs, flowers and foliage—Ornamentation of Ponds and Lakes. 300 pages, nearly 200 illustrations. Beautifully printed and bound. A charming book for landscape gardeners. Price \$3.50. With the Park and Cemetery one year, \$4.25.

**Ornamental Gardening for Americans**. By Elias A. Long. A treatise on beautifying Homes, Rural Districts, Towns and Cemeteries. A most valuable contribution to Gardening Literature. Treats on the materials required, the arrangement, construction and maintenance of gardens for homes, parks, cemeteries, etc., profusely illustrated. Cloth, price \$2.

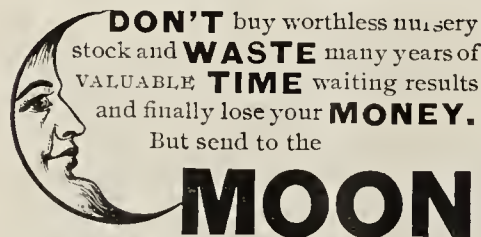
**The Nursery Book**, by L. H. Bailey, assisted by several of the most skillful propagators in the world. In fact, it is a careful compendium of the best practice in all countries. It contains 107 illustrations, showing methods, processes and appliances. How to propagate over 2,000 varieties of shrubs, trees and herbaceous or soft stemmed plants; the process for each being fully described. All this and much more is fully told in the Nursery Book. Over 300 pages, 16mo. Price, cloth, \$1. Pocket style, paper, narrow margins, 50 cents.

**The Spraying of Plants**. A succinct account of the history principles and practice of the application of liquids and powders to plants for the purpose of destroying insects and fungi. By E. G. Lodeman. Cloth \$1.

MEMORIAL RESTORER

Used by the war department, U. S. A in National Cemetery, Arlington, Va., and in New England and eastern cemeteries almost exclusively in preference to other methods. For terms, directions, etc address,

GREENWOOD & WOODLAWN CO.  
258 Broadway, New York City.



DON'T buy worthless nursery stock and WASTE many years of VALUABLE TIME waiting results and finally lose your MONEY. But send to the

MOON

Company who have the  
**FINEST NURSERY STOCK**  
at Reasonable Prices.  
New Catalog for 1896. Send for one. Free.  
Estimates furnished. Correspondence solicited.  
THE WM. H. MOON COMPANY, Morrisville, Pa.



*Garden and Forest* ably discusses the principles of landscape gardening as applied to the improvements and care of public grounds, and contains practical suggestions regarding the management of American Cemeteries, together with beautiful and useful suggestions.

"Should be in the hands of every progressive superintendent."—A. H. Sargent.

"I have gained much useful and practical knowledge from the numbers of *Garden and Forest*."—F. Eurich.

"*Garden and Forest* ought to be worth to any cemetery many times the cost of a year's subscription."—O. C. Simonds.

Published Weekly, \$4.00 a Year.

Specimen copy free on application.

Garden and Forest Publishing Co.,  
Tribune Building, New York.

L. H. Bailey, Professor of Horticulture, Cornell University, Ithaca, N. Y.,  
"PARK AND CEMETERY must fill a very great need. \* \* I shall be glad to contribute now and then."



Iron Reservoir  
VASES,  
LAWN SETTEES  
AND  
CHAIRS

Are Manufactured by

McDONALD BROS., Columbus, O.

The largest manufacturers of these goods in the world. We issue a large 40 page illustrated catalogue, which will be sent free on application. Mention this Paper.

Trees, Shrubs, Roses.

- 100,000 Maples: Norway, Silver, Etc.
- 100,000 Poplars: Carolinas, Lombardy, Etc.
- 500,000 Other Ornamental Trees 5 to 25 ft.
- 10,000 Weeping Trees in Variety.
- 100,000 Evergreens.
- 1,000,000 Shrubs All Kinds and Sizes.
- 200,000 Hardy, Out Door Roses.
- 500,000 Roses in Pots.

Greenhouse Plant, Bulbs, Hardy Perennials, Etc., in large supply. Everything of the best for *Park, Cemetery, Lawn, Conservatory, Orchard, Vineyard and Garden.* Correspondence solicited. Catalogue and price list free. Bed rock prices on large lots.

Write us, we can do you good.  
42 YEAR, 1000 ACRES, 29 GREENHOUSES.  
**THE STORRS & HARRISON CO.,**  
PAINESVILLE, OHIO, Box 1.



The TWIN GOMET and LITTLE GIANT  
LAWN SPRINKLERS.

Best Sprinklers made for Florists and Nurserymen's use—SAVE LABOR, for they sprinkle 4 times greater area than any other sprinkler.

E. STEBBINS Mfg. Co.,  
Made for Sole Agents and Manufacturers,  
J. B. FELLOWS & Co., Boston. SPRINGFIELD, MASS.  
Local Agents Wanted. Can make big money.

JOHN H. JACKSON Successor to JACKSON BROS. Established 1852  
NEW YORK STATE DRAIN TILE and PIPE WORKS. Main office 12 3d Av Albany, N. Y.  
Manufacturer of and Dealer in Agricultural Drain Tile, Salt Glazed Sewer Pipe, Red Pressed Brick, Mortar Colors, Fire Brick, Oven Tile, Chimney and Flue Lining, Chimney Tops, Fire Clay Stove Pipe, Fire Clay, Kaolin, Encaustic Sidewalk Tile, Rosendale and Portland Cement, Lime, Plaster, etc.



FOR-GET-ME-NOT Blue Perfection A PROFITABLE CUT FLOWER.

This flower is a saleable and profitable cut flower, and has averaged at wholesale in Philadelphia market this winter, from \$1.50 to \$2.00 per 100 flowers.  
READ WHAT TWO OF THE OLDEST AND BEST KNOWN HOUSES IN PHILADELPHIA SAY ABOUT IT.

MR. ALBERT KNAPPER:—This season we have worked up quite a little trade on Myosotis and consider it a good cut flower for the retail florist, which I think will grow more in favor.

MR. ALBERT KNAPPER:—We take great pleasure in recommending a good article and can say that your Myosotis is a fine, large, strong flower of a grand color, and the best we have seen for a great while.

A Good Investment. Easily Handled. A Good Keeper. No Disease. A Good Seller. Order Now.

Treatment similar to Violet Marie Louise or Carnations, from 40 to 50 degrees.  
Plants, 2 inch pots, ready for shipment, per 100, \$5.00; per 1000, \$40.00. Rooted Cuttings, ready for shipment, per 100, \$3.00; per 1000 \$25.00. Cash with order please or C. O. D.

ALBERT KNAPPER, Frankford, Philadelphia, Pa.



# PARK AND CEMETERY.

FORMERLY THE MODERN CEMETERY.

A Monthly Journal Devoted to Parks and Cemeteries.

R. J. HAIGHT, Publisher,  
334 Dearborn Street, CHICAGO.

Subscription \$1.00 a Year in Advance. Foreign Subscription \$1.50

VOL. VI. CHICAGO, JUNE, 1896. No 4.

## CONTENTS.

EDITORIAL.....	269
THE ARCHES, TOMBS, ETC., OF CHINA.....	270
*PROSPECT HILL CEMETERY, NORFOLK, NEB.....	270
THE ROMAN ROADS.....	271
*THE WASHINGTON MONUMENT FOR FAIRMOUNT PARK, PHILADELPHIA.....	272
*YUCCAS AT LINCOLN PARK, CHICAGO.....	273
*GARDEN PLANTS, THEIR GEOGRAPHY, VIII.....	274
*FRANKLIN CEMETERY, FRANKLIN, PA.....	276
THE LILY POND.....	277
GARDEN EXPERIMENTS IN SOUTHERN CALIFORNIA.....	278
*THE GRANT MONUMENT, RIVERSIDE PARK, NEW YORK.....	278
*THE GOLDEN LEAVED SCOTCH PINE.....	280
LEGAL.....	281
RULES FOR RECEIVING TRUST FUNDS.....	282
PARK NOTES.....	283
CEMETERY NOTES.....	284
CORRESPONDENCE.....	285
PUBLISHERS DEPARTMENT.....	286

\*Illustrated.

THERE will be an attractive and unique addendum to the annual meeting of the Association of American Cemetery Superintendents, to be held in St. Louis, Sept. 15, 17. It may not be generally known that in addition to the splendid Botanical garden the late Mr. Shaw left to that city, among many other bequests looking to the encouragement of the pursuit of knowledge of the vegetable kingdom, he bequeathed a fund, the income from which was to be devoted to providing an annual banquet, to which free but discretionary invitations were to be issued by the Trustees. It has been considered by these gentlemen that the cemetery superintendents easily come into the category, and the date of the banquet has therefore been arranged with a view to providing that body with the "feast of reason and flow of soul" which Mr. Shaw's wise bounty so efficiently provides. It will undoubtedly be an occasion long to be remembered, and be fraught with results unattainable,

perhaps, in any other way. We understand that an interesting program is being prepared for the convention.

IT is very rarely in the perusal of the many annual reports of parks and cemeteries that come to hand, that any reference is made to the "nursery," though this is more truly the case in cemetery than park reports; and it must therefore be concluded that the important adjunct of the "nursery" has not been given the attention it both deserves and commands. A park or cemetery of any extent lacks an essential element of economical and prudent management that has not established a special plot of ground, wherein the work of propagating, growing and acclimating the various plants, shrubs and trees that may be, or are required, more or less at every step of development or improvement, can be carried on. It cannot be on the score of expense that the omission is countenanced for it would be found that the "nursery" is an economical feature, requiring care, certainly, but care which can be bestowed as part of the regular routine of work; but possessing advantages self-evident on a moment's thought to any one familiar with plant life and growth. In the nursery, the peculiarities of the various kinds under cultivation can be observed, and a knowledge gained of their suitability to certain locations, or in relation to their surroundings when planted out. The more tender varieties can be made to gain in strength and become used to changed conditions. Appropriate and rare specimens from other sections of the country can be tested, propagated, and studied with a view to their possible availability or utility. And besides these special advantages of the "nursery," it becomes the storehouse of the plant requisites of the park or cemetery, wherein all the regular stock can be grown and cared for in quantity, and from which can be transplanted with nearly absolute certainty of success all the trees and shrubs necessary to create a landscape effect within the shortest possible time. Here is the general idea of the value of the nursery to the park and cemetery, and it can be established to any extent, more or less, as the probable requirements of the tract suggest.



**The Arches, Tombs, Etc.. of China.**

Some of the memorial arches or gateways are solid and massive erections, whilst others consist of perpendicular shafts of granite, stone, marble or wood, with horizontal ties; or, as in the more elaborate examples, with enriched entablatures, covered with projecting roofs at various levels, often with several spans in a row. They are usually erected by imperial consent in commemoration of those whose names are considered worthy of the reverence of posterity, to the honor of widowhood or virginity, or of some great or benevolent action. They are often elaborately pierced and sculptured, richly ornamented with bas-reliefs and inscriptions, the harmony of coloring rendering the effect greater than can be readily described. Some of these have been called masterpieces of Chinese art. \* \* \* Those covered with embossed and glazed tiles give one the impression of a complete and immense piece of porcelain.

The Woo-fuh-sze, or "Porcelain Gate," near Peking, is an elaborate structure, carrying the most minute and pointed detail and pierced by three pointed archways. There is a five-span marble memorial arch at the Ming Tombs, which, although of somewhat heavy construction, is of considerable historical interest, and immense numbers of these memorials are distributed through the country. There are few now remaining of a date anterior to the Ming dynasty, though history records many of much earlier periods.

The Mausoleums or Tombs of the emperors and grandees are, or were, imposing resting places. The Ming Tombs, now in ruins, near Peking, have been elaborately described by various authors. Here the ancient Ming princes, warriors and councillors found stately burial. The spacious roadways or avenues of approach to these sacred precincts were usually lined with colossal figures in stone or granite monoliths, of elephants, camels, lions, dogs, horses, mythical animals and men, in successive pairs at regular intervals—the approach to the Ming Tombs having thirty-two pairs of these images, the largest about 12 feet in height.

The "Tombs of the Kings," near the city of Nankin, was bounded by a wall some 14 feet high, enclosing an area of several acres; it embraced three large buildings separated by spacious courts. The first, the Hall of Entrance; then the Imperial Hall, constructed of wood, about 200 feet long by 100 wide, and containing the tablet of the deceased emperor. The roof covering was of yellow glazed tile, gleaming golden in the sunlight. The interior was decorated with minute and elaborate painting. It was supported by thirty-six wooden columns, about 40 feet high and about 3 feet in diameter at

the base, each a single stick of hard pine. The floor was of polished marble tiles. The third structure was of solid limestone masonry about 150 feet square. The edifices were surrounded by triple terraces, paved with finely hewn stone and enclosed with an elaborately wrought stone balustrade.

The family tombs of the wealthier classes are sometimes of considerable area, the high mounds surrounded with stately pines, and, where the natural formation of the ground lends its aid, often terraced with stone or granite walling, flights of steps, carved tablets and dragon guards, the whole enclosed with a wall or fence. Favorite places of burial are the sides of hills, the grave space varying considerably in the different provinces. A depression shaped like a horseshoe or the Greek letter *omega* is cut into the hillside, the curve toward the summit, a few steps leading up from the mouth of the shoe. The memorial tablet is placed erect upon the platform, or against the perpendicular wall of the hill. The sides are lined with stone, and mythical dogs or the Chinese Phoenix guard the entrance. A more general mode of burial is to place the wooden coffin containing the corpse on a stand, above or on the ground, sometimes merely thatched as a protection against the weather, the massive coffin being filled up with quicklime (unfortunately omitted in some instances.) When the financial condition of the family admits, this is enclosed with brick walls and covered with a tiny roof or a conical tumulus of earth. Cremation, once a national custom, is still practiced, but now confined to babies and Buddhist priests. In the southern provinces the dead are placed below the ground level, with raised mounds and small headstones. The greatest respect and reverence are accorded to all burial places; but although fancy runs riot in the form of tablets and grave enclosures, little real architectural effect is attempted in any but the Imperial Mausolea. The magnificent tomb which received the remains of the last Emperor of China is said to have occupied about fourteen years in execution.—*Architecture and Building*.

**Prospect Hill Cemetery, Norfolk, Neb.**

Norfolk, Nebraska, is a city of some 8000 inhabitants, situated about 130 miles northwest of Omaha, in the Elkhorn Valley, perhaps the most beautiful and fertile valley in the State. It is a great farming and cattle raising district, and also has one of the largest sugar refineries, operated very successfully.

The cemetery originally comprised ten acres of land, laid out in such a manner of straight lines of lots and roads that one third of the property consisted of roads. The desire for improvement and





extension resulted in calling in Mr. J. Y. Craig, landscape gardener and superintendent of Forest Lawn Cemetery, Omaha, to remodel the ten acres upon the lawn plan taking into consideration in his design the addition of twenty acres, and also with a further view of extending the whole when necessary. The accompanying plan which has been adopted, represents the new design, which had in a measure to conform to conditions imposed by the former sale of lots.

The original ten acres was donated to the town by the Hon. S. S. Cotton of Norfolk, who is president of the association now formed. The association was organized and rules and regulations have been formally promulgated.

The officers and board of Trustees are representative business men of the city, and there is also a Ladies' Society, who will give cemetery matters a very close attention. The adoption of the lawn plan does credit to the officers of the association as well as the city, and the development of the cemetery on these lines will afford a constant pleasure to the lot owners, and undoubtedly create an ever-growing interest in the community. If carried out in its integrity this little modern cemetery may be made a gem and form, not by any means the least attractive feature of a wide-awake town. If a community can be judged by the care bestowed upon its cemetery, Norfolk has a good start for general commendation.

#### The Roman Roads.

The Roman road was built for eternity. When the roadbed had been prepared by excavation it was carefully refilled, regardless of expense, with layers of sand, stones and cement, says the New York *Independent*. The surface was so solidly

dressed that the wear and tear was reduced to a minimum. Investigations with regard to the preparation of the roadbeds were made years ago by Bergier on Roman roads that are still in use in France, and with the following results: In one road the excavation down to hardpan was three feet deep. This trench was filled up first with a layer of sand and cement an inch thick; then came a foot layer of flattish stones and cement; then a foot layer of small traveled stones and cement. These last two layers were so hard and firmly knit together that tools could break off fragments only with great difficulty. The next layer consisted of a foot of cement and sand, covered with a top dressing of gravel. In another road in France the foot layer of cement and sand changed places with the layer of cement and traveled stones. A third road in France was examined at a point where it had been raised twenty feet above the level of the surrounding country, and a vertical section revealed a structure of five layers. First came the great fill of  $16\frac{1}{4}$  feet; on top of this fill they placed first a foot layer of flattish stones and cement, then a foot layer of flattish stones without mortar of any kind, then a half-foot layer of firmly packed dirt, then a half-foot layer of small gravel in hard cement, and lastly, a half-foot layer of cement and large gravel.

Paved roads were exceptional. An example of paved roads is the Via Appia, whose pavement consists of a hard kind of stone, such as is used for millstones. The stones of this pavement are carefully hewn and fitted together so precisely that the road often appears to be solid rock, and has proved to be so indestructible that after 2,000 years of continuous use it is still a magnificent road. Ordinarily, however, the top dressing of the road consisted of gravel and hard cement; and in the countless inscriptions, when such and such a governor is said to have restored a given road, reference is made to this top dressing of gravel and cement. The width of the military road was usually sixty feet, the raised center being twenty feet wide, with side tracks each of the width of twenty feet. In some roads the raised center was paved, while the side tracks were dressed with gravel and cement.

The *via privatae* and the feeders of the military roads were usually dirt roads. They were much narrower than the military roads; sometimes they had a width of only ten feet, and, indeed, the feeders of the Via Appia were only two feet wide, but paved. The width of the Roman roads, all told, varied, therefore, from 2 to 120 feet.

To travel on these old Roman roads creates profound reflection; the mind wanders over the centuries passed and dwells interestedly on Roman historical incident.

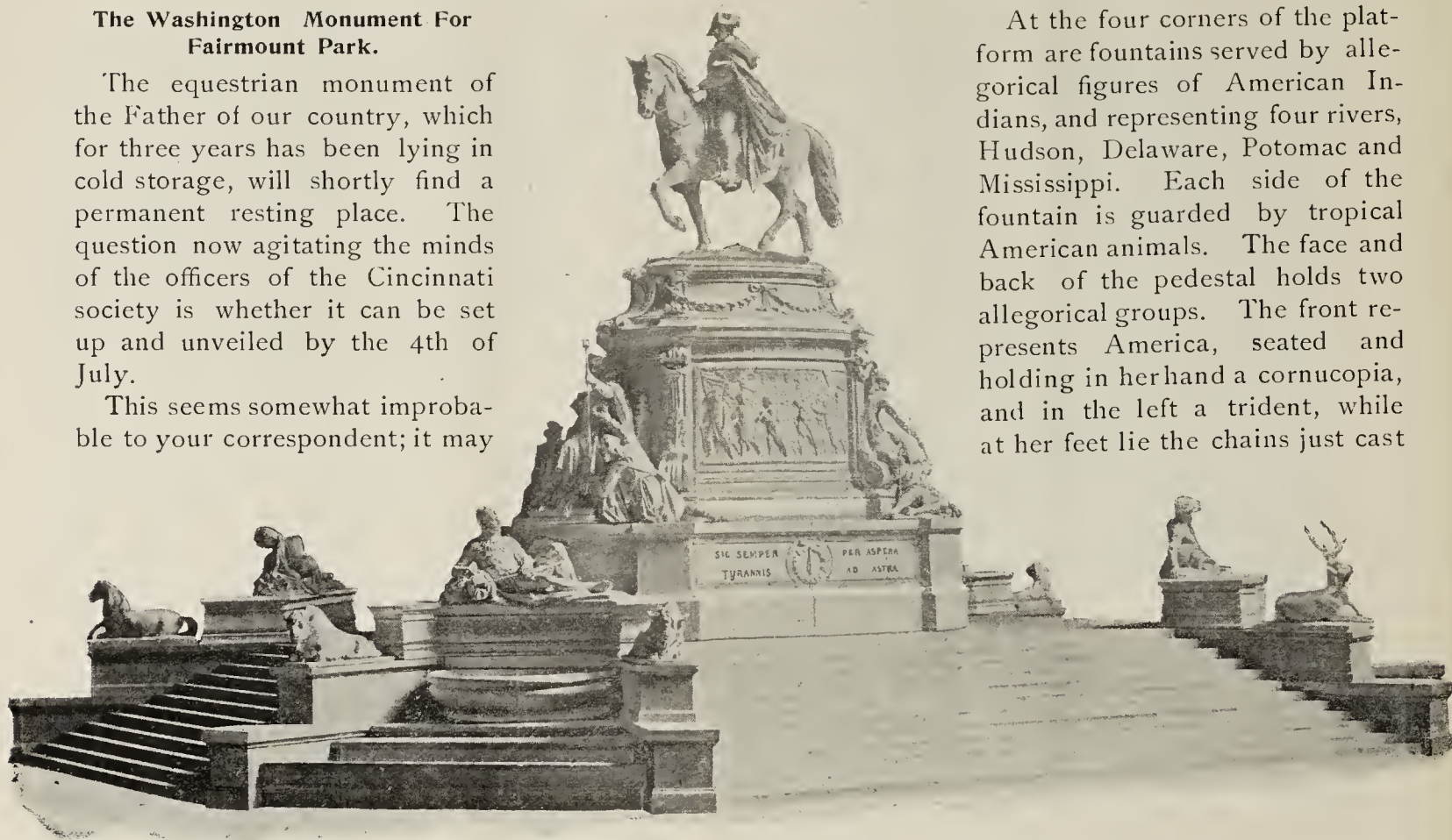


### The Washington Monument For Fairmount Park.

The equestrian monument of the Father of our country, which for three years has been lying in cold storage, will shortly find a permanent resting place. The question now agitating the minds of the officers of the Cincinnati society is whether it can be set up and unveiled by the 4th of July.

This seems somewhat improbable to your correspondent; it may

At the four corners of the platform are fountains served by allegorical figures of American Indians, and representing four rivers, Hudson, Delaware, Potomac and Mississippi. Each side of the fountain is guarded by tropical American animals. The face and back of the pedestal holds two allegorical groups. The front represents America, seated and holding in her hand a cornucopia, and in the left a trident, while at her feet lie the chains just cast



THE WASHINGTON MONUMENT, PHILADELPHIA.—Photograph of model by Broadbent Bros., Philadelphia.

be stated definitely however that if not unveiled on that very appropriate day, the unveiling will take place in the early fall.

By many it is contended that the fall month would be the better, as the cooler weather would be an inducement to distinguished strangers to be present.

Plans and specifications are now being prepared and the contract for the construction of the foundation will soon be awarded. All the sections are complete and the work of putting the same together will not take long.

The base of the monument proper is 77-5 feet in width, and 91- feet in depth.

The pedestal centred, bears the equestrian bronze statue of General Washington, clothed in the colonial uniform of the American army, topped with the chapeau bras; while from the shoulders the large military cloak has been brought in as a very graceful accessory. The left hand holds the reins of the horse, which stands upon three legs, the left fore leg being raised from the ground. The platform is oblong and rises from the ground six feet six inches. It is of genuine Swedish granite and is reached on the four sides by thirteen steps, (also of granite), symbolic of thirteen original states.

off. Thus she is in the act of receiving from her victorious sons the trophies of their conquest. Below this group the eagle supports the arms of the United States.

The group in the back represents America arousing her sons from the atmosphere of slavery. Below this are the arms of Pennsylvania. Two bas-reliefs occupy the sides of the pedestal, representing the American army in marching order.

On one side of the inscription "Sic Semper Tyrannis" and "Per aspera ad Astra," on the other "Westward the Star of Empire takes its Way" and upon the upper band of the pedestal is the legend "Erected by the State Society of the Cincinnati of Pennsylvania." The equestrian statue, the figures and the bas-relief and other details are all of bronze, while the platform, pedestal and steps are of Swedish granite; and surrounding this will be a gravolithic pavement twenty feet wide.

The height of the monument from the ground to the crown of the chapeau is 45 feet. The ground plan of the platform is 61 feet by 74 feet, and the pedestal 17 by 30 feet.

The monument is the work of Professor Leopold Siemering, of Berlin. The cost defrayed by the Cincinnati Society, is nearly \$250,000.

W. P. L.



## Yuccas at Lincoln Park, Chicago.

The accompanying illustration shows a rustic nook in Lincoln Park that I have long known and liked. It is a simple quiet place as inconspicuous in its way as a wild violet. A bank lying between the foot path in the foreground and a driveway eight feet above, on the level, and just beyond the planting, serves as a basis for a good naturalistic scheme that includes wild grapes climbing at will over small trees, shrubs in variety and Yuccas growing among rocks. A fringe of trees dividing the driveway from the embankment serves as a background and shelter to this admirable and attractive arrangement.

When I came upon this nook the first week in July '95 and found the Yuccas in flower I thought the effect pretty enough to be carried away by my camera for the readers of PARK AND CEMETERY. And to make the picture of more practical use, I learned through the kindness of Mr. Stromback, the park gardener, that the Yuccas were *Y. filamentosa* that had been planted three years, and that they are very hardy, requiring here only a slight winter protection of dry leaves. The plant surrounded by rocks, growing just below the large central spike of Yucca blossoms, is prostrate Juniper, (*Juniperus Virginiana prostrata*), and the shrub-like plant of weeping habit that stands beyond and higher on the bank than the same Yucca is *Lycium Barbatum* or Matrimony Vine. In the foreground at the left, two or three plants of *Rosa rugosa* stand under the shadow of an overhanging wild grape that makes a graceful canopy about a small tree. The soil of the embankment is sandy loam and is carpeted with

ordinary lawn sod. The component parts of this pretty effect are thus seen to be simple and easily obtained, but for an artist to be so familiar with his material as to unerringly produce such effects, and to have the taste to design them—well, that's another story.

Fanny Copley Seavey.

THE MANNA OF THE OLD TESTAMENT.—A Long Island correspondent, desires information as to what was the Manna of the Old Testament and sends the following from the *Christian at Work*.

"On the first Sunday in June the Sunday schools consider the subject of the supply of manna. It has been a question upon which commentators have differed—and upon what questions have they not differed?—as to whether a relation exists between the natural manna—the Egyptian *mannu*, being the exudation of the *Tamarix mannifera*—and the spiritual manna (Exodus xvi. et seq.) The Schaff-Herzog Encyclopedia says:

'The sweetish exudation of the tamarisk has nothing to do with the bread furnished by the Lord to the Israelites.' Smith's Bible Dictionary also says: 'The manna of Scripture we regard as wholly marvellous and not in any respect a product of nature'. Both these expressions are very positive; but Professor Franz Delitzsch thinks differently, holding that the gift of the quails and the gift of the manna are certainly correlated in our Biblical narrative. No one supposes the quails to have been specially created birds, but such as have been noted in Algeria, where acres of ground have been found covered with them at daybreak where there where none the night before. So it is claimed by Dr. Delitzsch the manna is the ordinary tamarisk juice, of which the Bedouins speak as, 'raining from heaven, because it falls from the trees like the dew.' Of course the subject is purely speculative; still it enters into a distinctive school of thought of to-day—that which draws upon the miraculous to that extent only in which the supernatural is necessary. In this view the same interpretation would be given to the manna as to the quail miracle, the supernaturalness being placed upon the miraculous abundance of the supply, and not upon the article of food."

It should be sufficient to say



A RUSTIC NOOK.



that no explanation based on natural phenomena, has ever been given.

It must not be forgotten that the occurrence was on a desert where no trees grew, and though it is possible that a few scrubby specimens of the *Tamarix* might be found here and there, the salty stuff it exudes called Jews' manna, would have been found every day, and there could be nothing miraculous on its appearance at the particular occasion cited.

There is absolutely nothing growing on that great desert that could furnish the article described. It is given to us as an absolute miracle,—and it could just as well have been accomplished in the shape of some absolute new farinaceous compound. Indeed the miracle would have been just as perfect if the Jews had been able to live for forty days without food at all. When things are given to us as miracles, what is gained by explaining them away?

The *Christian at Work* should know better.

Manna, as we know it, is the sap of an Ash tree, *Fraxinus Ornus*. This does not grow in Palestine.—*Mechans' Monthly for June*.

#### Garden Plants.—Their Geography. VIII.

##### GUTTIFERALES.

THE HYPERICUM, GORDONIA AND DIPTEROCARPUS ALLIANCE.

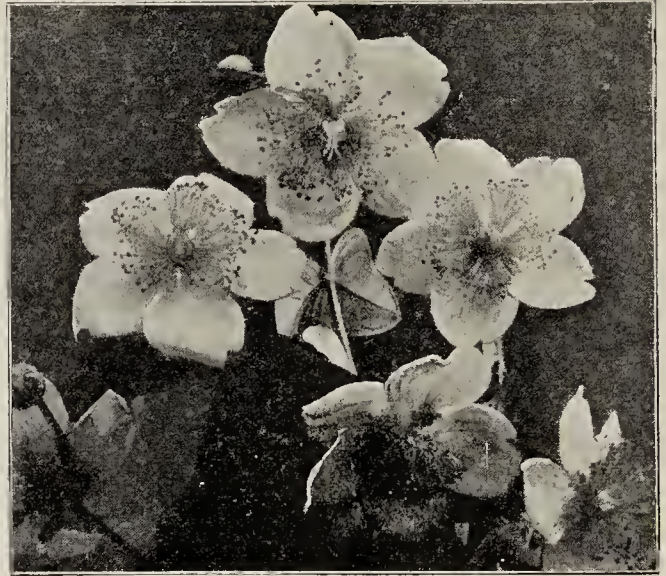
This group is largely confined to tropical and sub-tropical regions. It is composed of 17 tribes, 103 genera, and 1141 species of mostly handsome evergreen trees and shrubs, with comparatively few herbs.

*Elatinæ* is a small tribe of two genera, *Elatine* and *Bergia*, both represented in Southern U. S. plants. There are some 25 species, little annual marsh herbs scattered over the four quarters of the earth, and of no particular interest to any but Botanists. *Bergia aquatica*, an East Indian species is in British gardens however, and has yellowish flowers with dark stamens. They are called "water peppers" in consequence of their pungent taste.

*Acyrum* is a genus of 7 species, mostly small evergreens, natives of the United States, Mexico, the West Indies and the Himalayas. Four or five are in cultivation known as "St. Andrews Cross," "St. Peters Wort" &c.

*Hypericum* has 175 species distributed over the world. About 30 are found in the United States. A few are showy garden plants with yellow flowers, and often unsightly seed pods. Recently they have been hybridized and the *H. + Moserianum* is reported hardy as far north as New York, at least. One of its parents *H. calycinum* is regarded as British, has fine large flowers, and is a useful low growing plant for partial shade. Many others with smaller, more abundant flowers, such

as *H. aureum*, are seen in gardens, and several



HYPERICUM + MOSERIANUM.

sub-tropical shrubs are winter flowering.

*Clusia* has 65 species of trees and shrubs which are exclusively from the tropical and sub-tropical parts of America.

*C. Flava*, the "Hog plum" of the West Indies, is indigenous in S. Florida. *C. rosea*, said to be found in the Carolinas, and "hardy or half hardy" in the south of England, is a doubtful species at best.

*Garcinia* is a large genus of tropical trees, and includes the gamboge (originally called *Cambogia Gutta*) and also the superb fruit of the Indian Archipelago called the mangosteen.

*Mesua* is in three or four species of trees, natives of India and other parts of tropical Asia; the sweetly scented flowers are sold in the bazars in large quantities.

*Mammea* is the genus, yielding the delicious fruits of that name; there are five species distributed over the tropical parts of America, Asia and Africa. The plant once known as *M. Africana*, however, is now included under *Achrocarpus*. They are kept with protection



MAMMEA AMERICANA.

in S. Florida.

*Eurya* has probably 15 or 20 species, although more than this number are enumerated. They are natives of sub-tropical and tropical Asia, as far north as Japan and the Himalayas. Severa



handsome variegated and other forms are cultivated in greenhouses, and these should be tried in partial shade south, more particularly *E. Japonica*, *E. augnstifolia*, and *E. multiflora*. There is no reason why these should not thrive as well as the *Camellia*, and in similar situations.

*Actinidia* is a genus of Asiatic climbers and creepers in 8 species, some of which bear edible fruit. *A. arguta* is in our gardens, (advertised as *polygama*) and hardy to the lakes. It has leaves somewhat like the *Camellia*. Others of the species have handsome autumn foliage, especially one called *A. Kolomicta*. They have white flowers of no especial beauty, but as the plants are hardy, they are worth gathering together for a group which is not very lavishly represented in northern gardens.

*Stachyurus* is a little genus of 2 species from Japan and the Himalayas. *S. præcox* has racemes of flowers appearing before the leaves in spring.

*Stuartia* is a genus of 6 species confined to North America and Japan. Our native species are supposed to be two, *S. pentagyna*, and *S. Virginica*; they are handsome summer flowering small trees or shrubs, not very reliably hardy in the young state north of central New Jersey. *S. pseudo-Camellia* the Japanese species is also in cultivation, it is summer flowering, handsome and perhaps a trifle more hardy than its American congeners.

*Gordonia* is also a beautiful genus of 25 species, the tropical and sub-tropical species being evergreen. They are largely from Asia. There are Mexican and United States species however, and the natives are hardy as far north as Delaware, where they become deciduous. *G. Pubescens* is the hardier; *G. lasiantha* is found along the south Atlantic coast, and is known as the "loblolly bay."

*Camellia* includes the tea plant and 15 other species, all natives of tropical and sub-tropical Asia. They inhabit regions having a considerable



CAMELLIA THEA.  
The Commercial Tea Plant.

rainfall and humidity in the season of growth; the triangle embraced within lines from Baton Rouge La., to Montgomery Ala., to Tallahassie Fla., will be found most suitable to many of them. I pointed this out often years since in relation to the tea plant, but the clever Washington farmers knew better, and spent many thousands of dollars in repeating experimental failures tested and tried nearly two centuries ago!

The *Dipterocarpeæ* are mostly large trees scarcely at all represented in our gardens. In large park conservatories some of them might be well worth growing. They are often grand and symmetrical in proportion, with handsome large foliage, and



DIPTEROCARPUS TRINERVIS.  
(After Lindley.)

although the flowers rarely make a great show on the trees, they are often in handsome clusters, succeeded by highly colored winged seeds. Many yield oils and unguents, which are fine illuminants. *Shorea robusta* is the famous "Sal" timber of the lower Himalayas. There is no reason why it should not prove hardy far south.

*Dryobalanops* is another genus of large trees in three species and of the same affinity, all natives of the Indian Archipelago. *D. aromatica* yields the Borneo hard camphor and oil of commerce, a much superior article to the product of *Cinnamomum camphora*, or, than the spurious kind obtained from turpentine. Most of the trees of this tribe produce some kind of gum, resin or varnish, and these are extensively used in India for a variety of purposes. The resin of *Dipterocarpus trinervis* is used for torches, plasters and other uses, and in burning smells agreeably.

*Chlanaceæ* is a small tribe composed exclusively of plants from Madagascar. I do not remember ever to have seen one of them, but they are said to be often quite handsome. With a single exception the genera are named with uniform terminology—such as *Sarcoæ*, *Schizolena* *Leptolena* &c.; a sufficiently unusual circumstance with the inventors of plant names. *James MacPherson*.

The olive tree in Tuscany is propagated either from seed or from "ovoli"—those protuberances provided with "eyes," which grow on the main roots and at the base of the trunk of this ancient of trees.



## Franklin Cemetery, Franklin, Pa.



Franklin Cemetery, Franklin Pa., is located about a mile from the Court House of Venango County in Sugarcreek Township, and is reached by a good road

and sidewalks making it of easy access to the community interested. As will be observed in the large illustration, it has a beautiful slope, falling towards the east and south, and nature has contributed largely towards making the site eminently satisfactory for cemetery purposes, combining these with extensive views of the adjacent country, which is picturesque in its variety of land and water scenery.

The Franklin Cemetery Company was incorporated on April 29, 1869, and in the following year twenty acres of land were purchased, to which have since been added several small parcels of land, four acres of which were purchased this year, while the Board of Managers have in view a further adjoining ten acres which will suffice for the locality for many years to come. Franklin has some 6000 inhabitants.

Dr. A. G. Egbert was the first president of the company, who by assiduous attention and sacrifice of time and means gave a standing to the cemetery. During the past six years only one change has

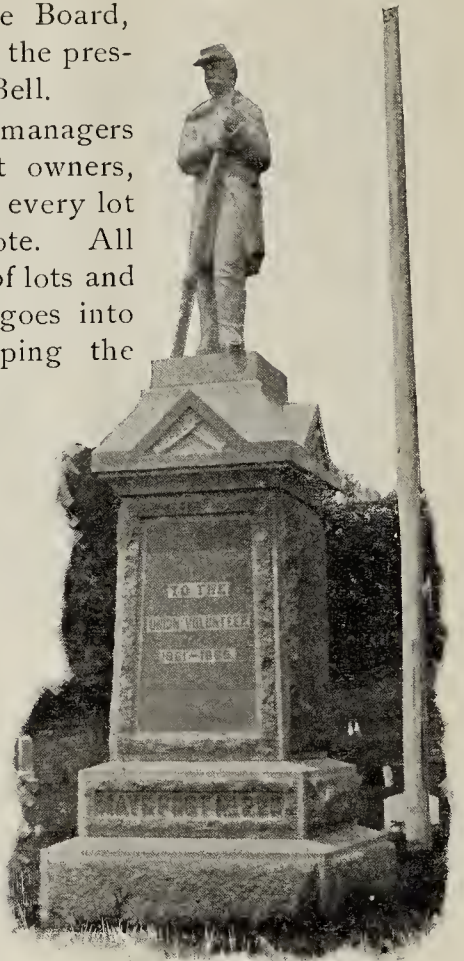
taken place in the Board, due to the death of the president, Mr. Joseph Bell.

The board of managers consists of five lot owners, elected each year, every lot owner having a vote. All receipts from sale of lots and digging of graves, goes into the fund for keeping the grounds in order.

At her death last year, Mrs. C. T. Eaton bequeathed five hundred dollars for a fund for perpetual care, and the Board now thinks of setting aside one fifth of the receipts to swell the fund for that purpose.

Last year 34 lots were sold and 180 prepared for sale, making a total

of 984 lots ready for disposal. During the year ending April 1, 1896, there were 98 interments, which included 5 veterans of the late war. The soldiers monument illustrated, is erected on a lot given by the corporation to the W. B. May's Post, and twelve men lie buried there. The monument



FRANKLIN CEMETERY, FRANKLIN, PA.



is of Barre and Quincy granite and was placed there by the people of the city and vicinity.

There is only one hedge and three copings about the lots left, and the walks and paths are level, the lawn idea controlling. On the high ground is a drilled well and wind pump and tank. A strong unanimity of feeling exists toward the improvement and care of the cemetery, the ladies taking an active part, and Mr. C. D. Phipps, the superintendent, is cordially encouraged by those whose interests he serves. The opening illustration shows the superintendents house.

#### The Lily Pond.

A casual glance at a Lily pond reveals two well-defined characteristics: Plants with foliage and flowers standing far above the water, and those with their leaves and pads afloat on its surface. Chief among the first-class is the "Lotus," whose grandeur and beauty defy alike the powers of the pen and the brush. Its massive pea-green foliage of peltate leaves, resembling inverted umbrellas, stands six to eight feet above the water, each with a fairy lakelet of molten silver dreaming in its bosom. Surmounting the wilderness of green, the individual flowers arise like the gorgeous banners of the Orient.

Representing the second-class is the "Water Lily" proper, with its cordate and bronze-green foliage, interspersed with thousands of red, white and yellow blooms, either resting on the water or peeping like white kittens from the masses of tender foliage. Intermediate between these and the Lotus, *Nymphaea superba* asserts imperial supremacy, its foliage either vibrating a foot in the air or floating on the water like giant pie-pans, with its huge flowers, here like hemispheres of snow, launching their fairy canoe petals on the water, or there assuming a spherical form and reaching up above the tallest leaves, as if to clasp hands with the lordly Lotus.

Now we pass to the tender varieties, with their gently ruffled leaves, lying so flat on the water as to appear like pencil stains, with their red, white and blue flowers rising several inches above, to display their exotic riches. But chief among them, and undisputed mistresses of the floral kingdom, are the Victorias, with their enormous variable flowers, rocking and blushing on the gentle waves like veritable Amazons, and their gigantic leaves with upturned edges, any of which is large enough to sustain a miniature aquatic garden.

But a general view of the pond does not satisfy our longings. We draw near to touch and embrace, to acquaint ourselves with their singular habit. The leaves of the Lotus are strong and flexible. Water

thrown against them does not adhere, but glances off instantly. The uprights will hold a pint or more of water, and when overloaded the stems deflect, turning the water out, and at once resume their normal position. During a shower they may be heard pouring out their great bowls of water in every direction. The foliage of the *Nymphæas* is more flimsy, the surface appearing clammy or oily, and water poured on the leaves trickles off reluctantly. The root formations are equally varied. The smooth tuber of the Lotus, the nut-like offshoots of *Devoniensis*, and the thick, creeping rhizomes of *Candidissima* are quite unlike, and afford interesting study. But while the foliage and roots show such a diversity of forms, the flowers of all are wonderfully alike in their general outline. The petals of all are keel or canoe shaped, which enables them to ride the waves in a most novel and suggestive manner. The stamens are numerous, filiform, and quiver above the pistil with every motion of the flower. The petals of the Lotus are deciduous; those of all other species are persistent. The whole family of day bloomers open early in the morning and close in the afternoon. The night bloomers open about 8 o'clock in the evening, and close about 10 o'clock in the morning. The flowers of the *Pontederias* and *Limnocharis* last but one day; those of the Victorias two days, and change from pure white to dark red. The Lotus opens four days, and fades from red or yellow to almost white. The *Nymphæas* last from three to six days, according to the condition of the weather. The seeds of the Lotus ripen far above the water, in a torus resembling an inverted cone. The *Nymphæas* close their petals firmly and drop beneath the water to ripen their seed, while *N. superba* and some few others curiously draw their seed pods into the mud by a spiral coiling of the flower stem.

Now, let us add the living reality to the scene. Swarms of bees, butterflies and humming birds, regaling themselves on the exuding nectar; birds bathing in the water and sipping from the dainty lakelets on the foliage; the huge green frog basking his uncouth and bloated ugliness on the floating leaves—and the picture is still incomplete! For, true to its placid beauty, the water intensifies the scene by portraying all these by inverted images, as if their antipodes had pierced the earth and offered their counterpart to glorify the American scene. Then we have it complete—the panorama that seizes alike the wonderment of the old foggy, who never sees the finest flowers and shrubbery of the yard and lawn, the admiration and praise of every lover of flowers, and makes a lasting impression upon the mind of every visitor and passer-by.

Smith's Grove, Ky.

George B. Moulder.



#### Garden Experiments in Southern California.

A correspondent forwards the following highly interesting letter on garden experiments in Southern California—and we feel sure we will be pardoned for editing and publishing it:

Ours is purely an amateur garden; briefly I will sketch our status. A year and a half ago, a few of us conceived the idea of an experimental garden where tropical plants could be grown, and such others as are uncommon or not known at all in gardens in the U. S., that is to say in the open ground. We succeeded in getting the city to allow us to use 10 or 15 acres of land in a tract called Elysian Park, which latter contains 600 acres; our tract is free from frost, rich but light sandy loam, with irrigating system already supplied. This was the beginning; since then we have set some 400 plants, including palms, trees, shrubs and climbing plants. No attempt has been made to group the plants in genera (or otherwise? *Ed.*) by themselves, except where incongruity was too obvious—the bamboos are by themselves. So with the palms and conifers—trees have been planted more with an eye to their future development. Climbing plants are set against an eight foot trellis 1000 feet long. We also have the nucleus of the more showy or interesting of Californian plants; a little later a collection of cacti and the rarer bulbs, principally those from South Africa. Also the *Crinum*s and other amaryllidaceous plants, nearly all of which flourish in the open ground here—in fact I have 14 species of *Crinum*s in my own garden, including *C. amabile* and a number of the *pancratium*s.

Our garden will doubtless have many defects, but we will have to content ourselves with the thought that no where else in the U. S. will so many tender plants be seen in the open ground.

Our list of palms in the open so far, includes: *Arcontophœnix Alexandræ*, *Howea Fosteriana*, *Cocos plumosa* and *Pritchardia gaudichaudiana*, among the tender ones; and *Chamaerops*, *Livistonia*, *Gabal*, and *Erythea*, also *Jubæa*, among the hardier ones. Among tender climbing plants, we have: *Bougainvillea*, *Allamanda*, *Stephanotis*, *Schubertia*, *Tacsonias*, *Passifloras*, *Bignonia*, *Cryptoslegia*, *Ipomœas*, *Beaumontia*, *Quisqualis*, *Thunbergia*, *Jasminums*, etc. and a number of less tender climbing plants. The splendid hardwooded shrubs of New Holland are almost unknown here. Yet in a few private gardens they exist in great vigor. So it is our idea to accumulate as many as possible, also the fine sub-tropical shrubs, a good many of which do nicely; such as: *Tabernæmontana*, *Plumeria*, *Bauhinia*, *Michelia fuscata*, *Murraya* and some of the *Gardenias*. Among interesting flowering trees, *Castanospermum*, *Calodendron*, *Kigelia*, *Jacaranda*

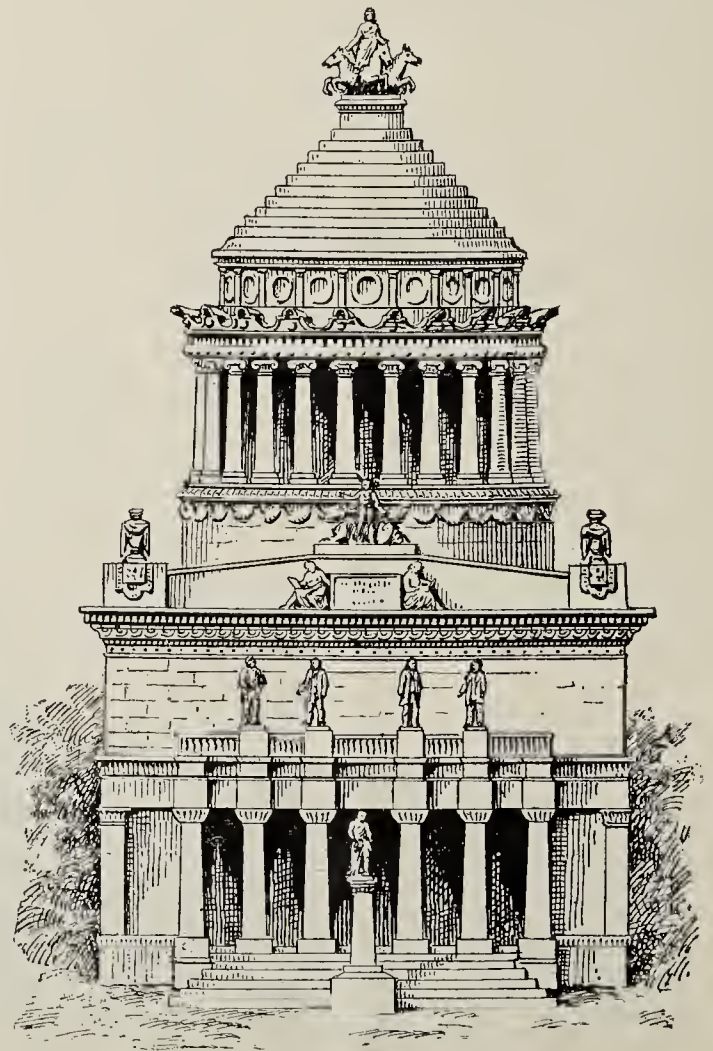
and others do well. *Colvillea racemosa* promises fairly well when it gets stronger, *Jonesia Asoca* however dwindles away, so with *Amherstia Nobilis*; we think we may succeed with *Brownea* and hope for *Michelia Champaka* a little later. If we could get *M. niligirica* it would surely succeed (if obtained from the Eastern slope. *Ed.*) Our climate is very peculiar, a vast number of strictly tropical plants do very well, while by their side grow the Cape bulbs, Violets, *Narcissus*, *Convallaria* and others which would fail utterly in a thoroughly tropical country.

*J. C. Harvey.*

#### The Grant Monument at Riverside Park, New York.

The exterior work of the Grant monument in Riverside Park, New York City, is nearing completion, and the main features of the design becomes apparent. The accompanying illustration gives the front elevation of the pile, with suggestions of the statuary which will finally adorn it. It is constructed of Maine Granite, quarried at North Jay.

The interior is far from complete, and it is not expected that the building will be turned over to the Monumental Association until April next. The interior will be handsomely finished, a large amount



THE GRANT MONUMENT.



of marble being required. The main portion under the great dome will be called Memorial Hall, and directly under the dome a circular opening eighteen feet in diameter, protected by an iron railing will show the sarcophagus in the crypt below. The four square corners of the structure will be utilized, the two on the south have stairways leading to the crypt, wherein visitors may pass entirely around the sarcophagus and read the inscriptions thereon. The two corners on the north will contain relics and interesting souvenirs of the great general.

It is promised that the first of August will see the scaffolding removed from the building and the last bit of exterior mason work done. After the scaffolding and fences are removed, the landscape gardeners will begin their work, and notwithstanding the lateness of the season, an attempt will be made to get the grounds into as presentable a condition as possible, although the planting will be deferred until next spring. The grounds will be sodded and gravel walks prepared.



Hang her an epitaph upon her tomb.  
*Shakespeare.*

Although the tendency of the times in regard to the epitaph is conciseness and simplicity, yet there are many old ones as well as those of recent date, in which the subject or the author lends a charm to the composition and instructs as well as consoles. The following are such examples:

In Chiswick churchyard, England, is buried the great painter, William Hogarth. His epitaph was written by David Garrick:

Farewell, great painter of mankind,  
Who reached the noblest point of art,  
Whose pictur'd morals charm the mind,  
And through the eye correct the heart.  
If genius fire thee, reader, stay,  
If nature touch thee, drop a tear;  
If neither move thee, turn away,  
For Hogarth's honor'd dust lies here.

One of the most beautiful of all the inscriptions in English churchyards is that indited by Leigh Hunt over the grave of the "Dairyman's Daughter," at Arreton, on the Isle of Wight. The touching simple story of her life has been told in many langua-

ges; its fragrance has permeated through palace and hovel alike:

To the memory of Elizabeth Wallbridge:

The Dairyman's Daughter,  
Who died May 30, 1801, age 31 years.  
Stranger, if e'er by chance or feeling led,  
Upon this hallowed turf thy footsteps tread,  
Turn from the contemplation of this sod  
And think of her whose spirit rests with God.  
Lowly her lot on earth; but He, who bore  
Tidings of grace and blessings to the poor,  
Gave her His truth and faithfulness to prove  
The choicest pleasures of His boundless love—  
Faith, that dispelled affection's darkest gloom;  
Hope, that could cheer the passage to the tomb;  
Peace that not Hell's dark legions could destroy,  
And love, that filled the soul with heavenly joy.  
Death, of its sting disarmed, she knew no fear,  
But tasted heaven, e'en while she lingered here,  
Oh! happy saint, may we, like thee, be blest—  
In life be faithful and in death find rest.

One of the most curious inscriptions to be found in the parish churches of London is that at St. Martin's in commemoration of one Florens Caldwell:

Earth goes to	}	Earth	{	As a mould to mould;
Earth treads on				Glittering in gold
Earth as to	}	Earth	{	Return ne'er should
Earth shall be				Goe where he would.
Earth upon	}	Earth	{	Consider may,
Earth goes to				Naked away;
Earth though on	}	}	{	Be stout and gay;
Earth shall from				Passe poore away.

Be merciful and charitable,  
Relieve the poore as thou art able;  
A shroud to thy grave  
Is all thou shall have.

Inscription on a boulder near Confederate Monument, Oakwood Cemetery, Chicago:

CENOTAPH.

To those unknown heroic men  
Once resident in the Southern States,  
Martyrs of human freedom,  
Who at the breaking out of the civil war,  
Refused to be traitors to the Union,  
Who, without moral or material support,  
Stood alone among ruthless enemies,  
And after unspeakable suffering either  
Died at their post of duty,  
Or abandoning home and possessions,  
Sought Refuge  
And scant bread for their families,  
Among strangers at the North.  
To these pure patriots, who  
Without bounty, without pay,  
Without pension, without honor,  
Went to their graves,  
Without recognition, even by their country,  
This stone is raised and inscribed,  
After thirty years of waiting,  
By one of themselves.



### The Golden Leaved Scotch Pine.

The common Scotch pine is much used by planters, because of its hardiness, quick growth and the silvery color of its foliage, and when it gets of large size, so as to expose its trunk, there is seen a reddish colored bark which adds to the attraction of the tree. This tree is largely planted in England, both for ornamental and commercial purposes, though of very little use in commerce, the timber being not nearly the equal of other woods. But it is quick growing and the climate is its own and there is a great deal of it set out. It is much used for sheltering in large parks as well as for landscape work, so that in passing through the nurseries there, one is prepared to see a great quantity of it. There are also in the nurseries a great many varieties of this pine. I think the European nurserymen are more alert than ours are to the value of varieties, and there is no doubt that they have more customers for such curiosities than we have. When visiting there last summer I noticed many dwarf forms of the Scotch pine, but specimens of the one illustrated herewith, the golden leaved, I do not remember to have seen.

The photograph of this one was taken from a fine specimen in Fairmount Park, Philadelphia, by permission of the commissioners. Mr. Charles H. Miller, the landscape gardener in charge, tells me it was set in its present position soon after the close of the Centennial in 1876. As it is now but about ten feet high and twelve feet wide, it will be seen what a slow growth it makes. This slow growth fits it well for the position it occupies, which is the front of taller evergreen and deciduous trees. The color of the foliage in this tree is a light golden one. In that of small plants propagated from it, in rich soil, it is more of a rich golden yellow, probably from the extra vigor of such trees. The dwarf evergreen shown on the left of the picture is a dwarf white pine, another useful one for such situations as it occupies. Immediately behind the dwarf golden Scotch pine is a fine specimen of *Pinus Mandshurica*, and to the left of it one of the common white pines, the branches of the deciduous tree visible being of the black oak. The illustration gives a good representation of its habit.



THE GOLDEN LEAVED SCOTCH PINE.

### Changing Our Mourning Customs.

“One of the surest indications that, as a people, we are tearing away from barbaric customs,” says the *Ladies' Home Journal*, “is found in the changes which, slowly but surely, have come over our mourning customs and funeral emblems. The time is not so far back when the announcement in a funeral notice that ‘friends will please omit flowers’ was an unheard of thing. When this first appeared people wondered at it. \* \* \* Now one meets the

request in numerous cases, and the effect has been good. ‘Gates Ajar’ and similar vulgar floral monstrosities are being discarded, and the modest laurel wreath or cross, or sheaf of wheat have in good taste supplanted them. Flowers for the dead are not to be decried so long as they have a meaning or carry a message of tender sympathy to the living, or attest a love, reverence or respect for the dead. But when offered missionless, in profusion, jammed or crammed into every imaginable made-to-order-looking design or device, the custom (or habit) of thus remembering the dead becomes offensive and is best honored in the breach.” That paper also expresses hearty satisfaction that the day of big funeral corteges is passing, and the heavy black crape at the door of the home which death has entered has been supplanted by simple, unobtrusive wreaths of green or blossoms. With equal gratification it notes that the sight of young children, fairly stifling beneath the heavy folds of mourning, is becoming more and more rare. In this connection it says: “We never thoroughly understood until recently the depth of affection and the sure, sane judgment which prompted that

*Joseph Mehan.*



member of my family, who, when he was dying, asked that his wife and children should refrain from wearing anything which savored of mourning at his passing. It was difficult to do; the heart seemed to prompt otherwise. But it was done, and the wisdom of my father's dying wish has often come home to his survivors when they have seen the custom followed which has made relatives and friends sombre just to look at each other."—*Western Undertaker*.

---

#### Legal.

##### LIABILITY FOR ILLEGAL DISINTERMENT.

A decision of the utmost importance has been recently rendered by the supreme court of Utah in the case of *Thickfield v. Mountain View Cemetery Association*. This was an action to recover damages from the association for entering upon a lot which it had sold, and disinterring the body of a dead child, and interring the body of a stranger therein. A judgement for \$1,150 and costs was obtained.

The lot referred to was sold in 1889, without any deed being given for it. In 1891 the association made another sale of it, for \$16, giving the purchaser a written instrument therefore, which second purchaser had the remains of his child buried therein. Shortly after, the first purchaser discovered what had been done, and thereupon made complaint to the secretary of the association, who promised to remove the body of the child. Something more than a year after its interment, it was removed and interred in an adjoining lot, while the mother of the first purchaser of the lot was buried therein. No notice of the removal was given to the parent of the dead child.

Under these circumstances, the supreme court affirms the judgment rendered below. The court says it will be observed that no opportunity was afforded the child's father, or any of his friends, to witness the removal and reinterment, so that he might know of his own positive knowledge the final resting place of his child. The removal had been in contemplation for a year, and yet during all that time no attempt was made to confer with him. He was treated by the cemetery association as though by the interring of his child he had lost, not only all rights to its body, but also to the lot which he had purchased. This was no assumption warranted by the law, while it is true that after burial the dead body of the child was not the subject of property, but became a part of the ground to which it was committed,—“Earth to earth, ashes to ashes, dust to dust,”—still the cemetery association had no right to break the parent's inclosure with impunity, and, as appears, regardless of the mental suf-

ferings which such an act would produce on the part of the father, to whom the dead was sacred, remove the remains, without his knowledge or consent. One who thus negligently disturbs the remains of the dead after burial does so at his peril; and the degree of his liability will be in accordance with the degree of negligence, or willfulness, or wantonness.

From an examination of the evidence in this case, continues the court, the conclusion is irresistible that the trespass was willful, being characterized by a wanton and reckless disregard of the rights of the father of the child. In estimating the damages, the jury had a right to take into consideration, not only the injury to the property, which was comparatively trifling, but also the injured feelings of the father. In such a case aggravated damages are allowable because of the wantonness of the injury, which might have been averted by ordinary regard for human feelings or mental suffering.

Complaint was also made by the association that the verdict in this case was excessive. But the supreme court says that it is unable to conclude that the damages are so exorbitant as to warrant a reversal of the case. The judgment of the jury, and not the opinion of the court, must govern, unless the facts disclosed by the evidence show that the jury was misled by some mistaken view of the merits of the case, or were under the influence of partiality, passion, or prejudice. And the jury must necessarily be permitted to exercise a wide discretion.

##### BOUND TO PAY FOR COPING.

There was coping around one of the lots in a cemetery which so pleased a certain lady that she authorized a party to have it constructed around her lot similar to and of the same quality of material as the other. In order to get bids for the work, this agent prepared a sketch and some specifications for the coping. The lowest bid thereof, \$470, was accepted. The lady told her agent to have the work done, saying to him: “You go on and do as you would for yourself.” The work was done, and the coping was like that around the other lot, and of the same quality of material. She saw it just before it was completed, and expressed herself satisfied. Subsequently she refused to pay for it, apparently because a discharged employe of the contractors told her that the rock used was “Loomis granite,” instead of “Penryn granite,” which the agent erroneously supposing had been used in the other coping had called for in his specifications.

But the contract for the work was a verbal one, to duplicate the other job, and when told that “Loomis granite” would be used the agent agreed



to it. Under these circumstances, the supreme court of California holds, that, even assuming that the sketch of specifications and the bid thereon were a contract, and that the use of the rock called "Loomis granite" was not a compliance with it, the agent in question had been given full authority to make or change any contract, providing he kept in view the construction of a coping similar to and of the same quality of material as the other coping referred to, and that the woman must pay for the coping she got.

#### ACCOUNTING OF CEMETERY COMPANY.

The court of chancery of New Jersey has decided several points of general interest in the case of the New York Bay Cemetery Co. *v.* Buckmaster,

An accounting was to be had between the company, which had control and right of sale of all lots in the cemetery, and the original owners of the site, who owned a large number of the lots.

The latter insisted that the company must show that each item in its list of charges was a proper charge for the maintenance of the cemetery, of which they should pay their proportion, while the company contended that the burden was on them to show that any particular item was not so chargeable. The court holds with the owners that it was for the company to prove what payments it made and that they were properly chargeable in this connection. Having charged up what was paid for labor, the court holds that moneys received by the company for interment fees and for work done by its men for individual lot owners on their lots should in equal proportion be placed to the credit of the parties to this action.

#### Rules For Receiving Trust Funds.

The following are the conditions under which gifts or bequests for the perpetual care of lots are received by the authorities of Forest Home Cemetery, Milwaukee, Wis.:

That, subject to such conditions and modifications hereof as may from time to time be adopted by a two-thirds vote of all the members of the Vestry of St. Paul's Church, Milwaukee, (they being the Trustees of said cemetery) all future gifts or bequests shall be received only on the basis that such amounts shall be invested to the best advantage, to be kept in a fund separate from all other investments, and that the income arising from such Special Fund shall, on the first day of May in each year, be apportioned as follows: One per cent. of the amount of said Fund shall be deducted from the income of said Fund and shall be carried into and added to the general Reserve Fund of the Cemetery, and the balance of the income of said

Special Fund shall be apportioned pro rata to the several amounts in such Special Fund, and the pro rata amounts so apportioned shall be the amounts that may be expended during the current year on the lot, or lots or graves for which each such gifts or bequests have been made. That all receipts or contracts hereafter to be given for such gifts or bequests shall be given on above basis, unless special securities shall be given in place of money, in which cases the income received therefrom shall be expended until such time as the securities so given shall mature or be paid, when the amounts realized therefrom shall be added to and invested with the Special Fund before stated, and the pro rata amount of the net income shall be apportioned to the amount received from such securities, and shall be the amount that may be expended on the lot, or lots or graves for which each of the gifts or bequests were made. Any amount left over unexpended for any year or years on any given lot, or lots or graves, shall be added to the amount allowed to be expended in any subsequent year or years.

No gift or bequest shall be entitled to any benefit from the income of the Fund unless such gift or bequest shall have been received at least one year prior to any first day of May.

No gift shall be received for a less sum than One Hundred Dollars.

#### Rules and Regulations.

The following extracts are taken from the recent publication of Pine Grove Cemetery, Lynn, Mass.:

PRICES FOR PERPETUAL CARE: For lots, per 100 ft. \$33.33; for lots under 200 square ft. and over 100 square ft., \$50.00; for lots containing 300 square ft., \$100.00; for lots containing 400 square ft., \$134.00.

\* \* \*

No burials will be made on Sunday. Bodies brought in on that day will be left at the tomb. No labor of any kind will be allowed on Sundays.

Lots not under perpetual care will be cared for at the rate of one cent per square foot. Lots remaining unpaid at the end of the year will not be cared for until paid. It is the desire of the superintendent to be notified at once if any lot is not receiving proper care.

No raised mounds over the graves will be allowed on the Public lots.

No headstones will be allowed over sixteen inches wide at the base and two feet high from the grade of the above lots; and the number of the grave must be cut upon the head stone.



PARK NOTES.

Ocean Springs, Miss., is moving toward a public park, and preliminary work is begun.

\* \* \*

A plan has been proposed which will provide Memphis, Tenn., with a series of small parks within the populous limits.

\* \* \*

The Park Commissioners of Peabody, Mass., have received notice that the bequest of Miss Proctor amounting to \$10,000 is now available.

\* \* \*

Bills have been introduced into Congress for appropriations both for a National Military Park, and a "Peace" monument, at Appomattox, Va.

\* \* \*

Under the recent activity in park matters for Brooklyn, nineteen new parks, in areas ranging between 535 acres and the city square, have been added to the responsibilities of the park authorities of that city.

\* \* \*

The Junior Endeavor Society of Madison Av. Presbyterian Church, Covington Ky., is taking the lead in connection with kindred societies of other churches to erect drinking fountains in certain locations in the city. At least 5 are expected to result from the efforts.

\* \* \*

Governor Morton of New York, signed the following bills in May: Bill authorizing the expenditure of \$150,000 by New York City to complete Riverside Park and Drive; Bill allowing \$10,000 to establish a park at intersection of 92nd st., Grand Boulevard and Kingsbridge Road.

\* \* \*

Layfayette Park, St. Louis, Mo., was in the very vortex of the May hurricane and is to a large extent a wreck from end to end. Every tree of any size was practically destroyed, huge stone vases, were seized by the wind and torn from their original resting places. The lake was filled with wreckage of buildings and debris of all kinds.

\* \* \*

South Bronx Park has been selected by the New York Zoological Society as the site of the new zoological park. The site embraces 261 acres of beautiful forest and meadow land on both sides of the Bronx River in the Annex District. It is said to be an ideal site selected from 3,500 acres of park land available. The new zoo will be free to the public six days a week.

\* \* \*

The Staten Island, New York, Chamber of Commerce has taken up a movement for the establishment of a system of parks in every part of the island. The plan is to appeal to the Legislature for authority to have a commission appointed with power to purchase and condemn tracts of land for park purposes, the commission to be limited in its expenditures to the sum of \$250,000. The plan has been indorsed by the Chamber of Commerce.

\* \* \*

Mr. Thomas H. Swope has made a princely donation to Kansas City, of land for park purposes. Mr. Swope is one of the city's oldest citizens, and the land in question is situated four miles southeast of the city and contains 1,314 acres. The only conditions exacted by the donor is that the land be named Swope Park and that the city during the next ten years expend at least \$5,000 a year in improving the grounds.

A petition has been forwarded to Washington, from Santa Barbara, Calif., asking Congress to forever reserve from settlement, for the purpose of a national park, two sections of land in the San Rafael Range in northern Santa Barbara County, including within their boundaries that beautiful sheet of water known as Lake Zaka. This lies at an elevation of about 3000 feet above sea level and is surrounded by a wild and picturesque mountain reigon. It is widely known as a health resort in summer and is a favorite resort with the pleasure-seeker and sportsman.

\* \* \*

At the meeting commemorating the twenty-fifth anniversary of the founding of the Fairmount Park Art Association of Philadelphia, the name of Col. Chas. H. Howell, the Secretary, was formally added to the list of Honorary Members. The Board of Trustees in conferring the honor voiced the following: "The Board feels it a just and pleasurable duty to acknowledge to Colonel Howell in this formal manner, the great value placed upon his services, services that have at all times and under many trying circumstances, been faithfully, efficiently and cheerfully performed."

\* \* \*

The following is approximately the number and acreage of park lands in many of the large cities: London, England, 150 parks, 5,000 acres; Dublin, Ireland, 2 parks, 1900 acres; Edinburgh Scotland, 15 parks, 1280 acres; Berlin, Germany, 83 parks, 1263 acres; Philadelphia, 40 parks, 3175 acres; St. Louis, 21 parks, 2180 acres; Chicago, 25 parks, 2148 acres; Minneapolis, 18 parks and a number of squares and triangles, 1552 acres; San Francisco, 24 parks, 1190 acres; Louisville, 9 parks, 1039 acres; Baltimore, 6 parks, 20 public squares, 911 acres; Buffalo, 5 parks, 900 acres; Detroit, 10 parks, 884 acres; Pittsburgh, 5 parks, 800 acres.

\* \* \*

Work on the Lake Front Park, Chicago, is progressing very well considering the magnitude of the undertaking. The lowering of the Illinois Central Railroad tracks, the construction of the sea wall, the filling up of the water area, ultimately to become landscape, are all being prosecuted simultaneously, creating a busy scene. A transformation has also been effected in Jackson Park, the scene of the Dream City of World's Fair time. It is difficult to realize the change, as well as difficult to lotate those beautiful buildings on the changed landscape. Although the park already possesses its special charms, it will be years before it will attain the perfection suggested in the accepted design; magnificent buildings may be erected in a year, but trees and shrubs, designed by nature's architect and carried to perfection under her unalterable specifications, in a general sense, improve year by year as time passes along.

\* \* \*

It was in Queen Anne's time that Addison and Pope first ridiculed the old style and sought to bring in the fashion of "copying nature." But the reaction and destruction of old gardens did not take place till later, when the theories they advanced had had time to spread. An extract from "A History of English Gardening" says: "There is no lack of views and designs of gardens of this period. If the authorities had foreseen the annihilation that was to fall on so many gardens they could hardly have more carefully preserved their designs. But these pictures are mostly taken from some imaginary point and give a bird's-eye view of the house, gardens and surrounding landscape in a conventional plan regardless of perspective. Faithful representations though they may be in many cases, the formal garden, as they show it, has lost all its poetry; the pale tints of the tender shoots of the beech hedges in the spring, the soft green of the sheltering views in winter, the secluded alley or the woodbine-covered arbor have no charm when set down in these stiff lines of black and white."



## CEMETERY NOTES.

An annual fair is held in May in Framingham, Mass., the proceeds of which are devoted to the care of Edgell Grove Cemetery. It is a ladies enterprise and this year has met with its customary success. This offers an excellent suggestion to other places to organize an annual effort for a similar purpose. Such efforts very rarely fail to secure returns.

\* \* \*

The annual report of Woodmere Cemetery, Detroit, Mich., shows: Receipts, Sale of lots \$18,346.42, work done \$12,112.59, Interest \$360.25, sundries \$5807.25, or a total of \$36,626.51. Expenditures, including interest dividend, \$30,704.71. Surplus \$5921.80. The Secretary, Mr. Joseph M. Thompson, died May 12, and Mr. M. H. Winters, Asst. Supt., was elected to succeed him. The season has been very favorable for landscape effects.

\* \* \*

There is evidently active interest manifested by the Gainesville, Fla., Improvement Society in cemetery matters. The ladies connected therewith are to have the use of the "*Daily Sun*" for one day in the fall to raise a fund to assist in keeping the cemetery in order. The plan now pursued is for each church to subscribe about \$4 per month, and a man is kept nearly constantly employed on the grounds. It would be interesting and instructive to know how the necessary enthusiasm is kept up in a climate practically all summer.

\* \* \*

The remains of Charles Carleton Coffin the noted war correspondent and prolific writer of histories and other literature for the young was recently interred in a lot in Mt. Auburn cemetery on Gentian path, adjoining the monument to Benjamin Franklin. Mr. Coffin was adopted by John A. Andrew Post No. 15 G. A. R. and that organization will, as a memorial, bear the expense of the purchase of the lot. The grave will be marked by a granite boulder from the "old farm" in New Hampshire, in which will be inserted a bronze tablet.

\* \* \*

In Harleigh Cemetery, Camden, N. J., the past year has been an unusually busy one in the way of constructing foundations for monuments. One new vault was also built for Dr. H. Genet Taylor. Harleigh has suffered for want of rain very much the past year, the rain fall having been very light, so that the prospect of being able to use city water in the near future is exhilarating. A new lawn of three acres has been prepared, upon which it has been decided to allow no grave mounds and to place all markers level with the ground.

\* \* \*

A number of the stockholders of Aspen Grove cemetery, Burlington, Ia., are endeavoring to perfect a scheme to insure the preservation of the cemetery for all time. The idea is to secure the signature of 25 well known citizens of Burlington, each of whom are to bequeath to the cemetery \$1,000, making a total of \$25,000, which is to form a perpetual fund, the interest of which is to be devoted to keeping the lawns, flowers and roadways in the very best repair and order. It is expected that the effort will meet with success, and is one that on the face of it seems both possible and practicable.

\* \* \*

The Trustees of Mt. Auburn, Boston, have broken ground near the northern entrance for a new chapel and administration building. From competitive designs submitted by several of the leading architects of Boston, that of Mr. Willard T. Sears was selected. The chapel is in the old English style and cruciform. The extreme measurements are 111 ft. by 40 ft., not including a

covered cloister nearly 12 ft. wide for the formation of processions. There will be a clergyman's robing room, large organ and other modern conveniences in the building. The administration building will be 60 ft. by 57 ft. and will contain a counting room, Supts. office, waiting room and Trustees room, all connected by a central reception room. A covered wing connects the buildings.

\* \* \*

A new cemetery, called Fairmount Cemetery, situated about 14 miles from the City Hall of Buffalo, N. Y., adjacent to Tonawanda, has recently been dedicated to public use. It contains some 190 acres, and the prospect of acquiring a neighboring farm will increase it to 240 acres. The work of improvement is being rapidly carried along, and the purpose is to perfect a cemetery on the modern lawn plan. One of the distinctive features of management is that one half of the amount realized from the sale of lots shall be set aside to form a permanent fund for the perpetual care of all lots. About one half of the grounds is now under active improvement.

\* \* \*

As a set-off to the oft discussed question of removing the hat in the cemetery at a funeral, Mt. Auburn Cemetery, Boston, has for some time used a tent practically the same as those of Forest Hills and Lowell Cemeteries, only larger. The conditions ruling necessitate a broad and high tent, and the size is 20x20 ft, but other sizes are proposed. The frame is of galvanized pipe in sections, so arranged as to go together quickly; but a more compact and readier design is being experimented with. An important question in relation to the use of the tent has been a fair charge; some cemeteries make no charge for tent, but a good price for matters pertaining to the grave. The Mt. Auburn authorities concluded to make the tent an optional matter and the charge for its use \$5. Present indications point to the use of the tent, more or less, irrespective of weather.

\* \* \*

Some fine memorials have been erected in the cemetery of Spring Grove, Cincinnati, during recent months. The McDonald Mausoleum is a fine work. It is built of Hallowell granite, in large blocks, one roof stone weighing over 27 tons. A figure of the same granite, stands each side of the doorway, one representing the "Morning of Life," the other "Night" or sleep. The interior contains 18 catacombs. The floor is of mosaic, and the ceiling is arched with panels of veined Egyptian marble. The inner doors are of granite with bronze panels, the double outer gates are of bronze of elegant design. Another beautiful structure is the Slimer vault, constructed of Hallowell granite about a year ago. It has 20 catacombs, and is one of the most substantial buildings ever erected. It is a graceful and chaste structure, and much admired. A much higher type of mortuary monument is becoming a feature in Spring Grove. A new entrance has been built to the cemetery, a mile and a quarter distant from the front gate. The posts are of Indiana white limestone, and the gates are good examples of wrought iron work. A handsome design for a lodge has been selected, but it will not probably be erected for a couple of years.

\* \* \*

The annual report of Greenwood Cemetery, Zanesville, O., shows receipts of \$8,970, which includes \$1,831 for sales of lots and \$1,005 for digging graves. The disbursements were \$2,634 for salaries and incidentals and \$2,418 for improvements. Zanesville has two city cemeteries owned by the city and controlled by three trustees elected by the voters. The people take pride in their cemeteries and claim to have the most beautiful and best kept of any city of its size in the country, 21,000 inhabitants.



The death rate in Minneapolis for the past eighteen months has been the lightest ever known, and the cemeteries are feeling the hard times. On the other hand some of the eastern cemeteries show by their reports to have done a much larger business in sales of lots and receipts than last year.

\* \* \*

The recent cyclone played havoc in a cemetery at Oakwood, Mich. All the monumental work was leveled to the ground with but few exceptions. The wind carried a cap weighing some 3,000 lbs. twelve feet away from the monument and lifted the die of the same monument, depositing it several feet away. G. C. Brown, Pontiac, Mich., writes that he has reset over 40 monuments and a large number of headstones and tablets. In many cases caps were carried so far it was difficult to find to what they belonged. A piece of a stone lid was driven through a white bronze monument, leaving a hole about eight inches in diameter. Much further damage has been done by relic hunters, thousands of people having visited the cemetery.

\* \* \*

In the report for 1895 of Greenwood Cemetery, Brooklyn N. Y., the sales of lots for 1895 amounted to \$187,162.95, a larger amount than that for any previous year. For single graves \$14,921 was received. The total amount of receipts including balances was \$568,243.68. Among the disbursements were: Labor \$135,664.76; Improvements, \$21,621.49; Maintenance, \$16,595.42. During the year \$143,263.26 was added to the general fund for the Improvement and Permanent Care of the cemetery, increasing this fund to \$1,848,065.32. For the Trust fund for the special and permanent care of lots, \$34,917.39 was received, the largest yearly sum recorded, increasing this fund to \$437,174.80. A hedge now completed surrounds the cemetery which in a few years will comparatively isolate it. The average number of men employed is 244; ranging between 110 and 366. The cemetery owns 21 horses and for the summer work others are hired as wanted.

\* \* \*

Lakewood Cemetery, Lake City, Minn., has issued its usual annual, containing the necessary information for the guidance of lot owners and purchasers, the annual report of the association, extracts from rules, regulations etc., and many paragraphs and quotations tending to the enlightenment of the lot owner looking to the welfare of the cemetery. It is especially pointed in the matter of perpetual care, in relation to which the secretary wisely says: "It seems to me a much more worthy expression of love for the departed to see that their last resting place is kept in a neat and tidy manner, than to erect a monument to their memory and then forget them and the lot in which they are buried." The publication of this little annual is a feature to be highly commended, especially to our smaller cemeteries.

#### A Natural Mausoleum.

One of the most curious mausoleums in the world was discovered recently, says *Public Opinion*, in an orchard at the village of Noebdenitz, in Saxe-Altenburg. A gigantic oak tree, which a storm had robbed of its crown was up for public auction, among the bidders happened to be Baron von Thummel, scion of a family of ancient lineage who lives on a neighboring estate, and who had ridden to the auction place quite accidentally. Finally the tree was knocked down to him for 200 marks. Upon his arrival at the castle he told an old servant of his purchase, describing the tree and its situation. The old servant said he remembered attending the funeral of a Baron Thummel seventy or eighty years ago, and that the body had been buried in a

thousand-year-old oak, belonging to the parsonage. Investigation clearly proved that the orchard had once been the property of the village church, and at one side of the old oak was an iron shutter, rusty and time-worn, that the people of the town had always supposed to have been placed there by some joker or mischievous boys. The iron shutter proved to be the gate to the mausoleum of Baron Hans Wilhelm von Thummel, at one time minister of the state of Saxe-Altenburg, who died in 1824, and wished to be buried "in the thousand-year-old tree he loved so well." In the hollow of the tree Baron Hans caused to be built a sepulchre of solid masonry, large enough to accommodate his coffin. The coffin was placed there, as the church records show, on March 3, 1824, and the opening was closed by an iron gate. In the course of time a wall of wood grew over the opening, which had been enlarged to admit the coffin and the workmen, and for many years it has been completely shut, thus removing the last vestige of the odd use to which the old tree had been put. The tree has still some life in it, and its rich verdure is only now turning a violent tint. The coffin in which Baron Hans reposes has on one side grown to the tree, the dead and the live wood joining together in eternal embrace.

## Correspondence.

LYNN, MASS., June 7, 1896.

*Editor Park and Cemetery,*

DEAR SIR: A short time since a communication appeared in your paper from our good Brother Nichols. He asked where is Brother Stonte, is he asleep? Far from it Brother Nichols, I will admit that I have been dilatory in writing. If I should attempt to offer an excuse it would be the old story, rush of business, but that is no excuse. I have been very busy with my usual spring work, which is the same in all Cemeteries. Memorial Day has gone and we can now breathe easy, but still plenty to do. The time is drawing nigh for our convention, and I hope we will all strive to make it a grand success, and that all who attend will go to their respective homes rich in knowledge gained. I am always pleased to take up the PARK AND CEMETERY, and read a communication from a Superintendent. It keeps us nearer together, although many miles are between us, yet the PARK AND CEMETERY does much toward bringing us in communion with each other, which is certainly beneficial to us as an association. Brother Nichols has woke me up and I hope I shall wake some one else up. I sent you a copy of our rules and regulations, and called your attention to the clause that prohibited work on Sundays. There is too much work done in cemeteries on that day. Some work may be necessary, but nine-tenths of the work done on that day can be done on a week day. Bodies brought in Pine Grove on Sunday are left at the tomb and buried on Monday. If any of the family are desirous of witnessing the burial they have that privilege. It is rarely a person asks to have a burial made on Sunday, and no applications are made to purchase lots. An officer is on the grounds to give directions to visitors. I have set out about a hundred trees this spring, different varieties of maples, cut leaf birch and purple leaf birch, and varieties of retinosporas. My lily pond is undergoing its spring renovating and I am looking forward to an attractive display of aquatics. I hope this communication will inspire others to write, so that we shall see a goodly supply in the July number. I think we would like to hear from Brother Phipps. He was not at Richmond, and we missed him much. I am writing five miles from Brother Creezy and am near enough to keep him toned down. I think I will wake him up to write something for the July number. More anon.

*William Stone.*



### Association of American Cemetery Superintendents.

O. C. SIMONDS, "Graceland,"  
Chicago, President  
G. W. CREESY, "Harmony Grove,"  
Salem, Mass., Vice-President.  
F. EURICH, Woodlawn, Toledo, O.,  
Secretary and Treasurer.

The Tenth Annual Convention will be held at St. Louis, September, 15, 16 and 17.

### Publisher's Department.

NOTICE TO SUBSCRIBERS. If this notice is marked with a blue pencil it indicates that your subscription to PARK AND CEMETERY has expired and a renewal of same is solicited.

Park Commissioners and Cemetery trustees are requested to send us copies of their reports.

Photographs and descriptive sketches of interesting features in parks and cemeteries are solicited from our readers.

PARK AND CEMETERY wants the names of every park and cemetery official or employee who would be likely to be interested in this paper. To the many subscribers who have sent in such list of names, we return our thanks. There are many more that we should hear from.

Subscribers are again reminded that we want brief notes on any feature of park or cemetery work that will be of general interest. PARK AND CEMETERY is the only publication of its class and earnestly solicits the co-operation of subscribers in making it a help to all indentified with such work.

The twenty-first annual convention of the National Nurserymen's Association held in Chicago this month brought together a large number of representative nurserymen from different parts of the country.

Among the many papers read and discussed was one by Prof. L. A. Bailey of Cornell University on "The Nursery Lands of New York State."

Resolutions were adopted in favor of the highest possible tariff.

The meeting next year will be held at St. Louis, Mo.

#### Personal.

Prof. Lucien M. Underwood of the Alabama Polytechnic Institute, Auburn, Ala., has been elected professor of Botany in Columbia College, New York, to succeed Prof. Britton, who becomes director of the new botanical garden in that city.

Mr. C. S. Bell, Supt. Lexington Cemetery Co., Lexington, Ky., paid a visit to his native country, Scotland, last summer after an absence of over 50 years. While in Scotland he was particularly interested in the trees he helped to plant when a boy, and especially in a Douglas spruce which he was familiar with in 1838 as a small tree four or five feet high, but which is now a beautiful specimen. This is a tree Mr. Robert Douglas of the Waukegan Nurseries, favors so much.

Wm. Salway, Superintendent Cemetery of Spring Grove, Cincinnati, O., with other members of his family, have just left for a three months trip to Europe. After spending a short time in Scotland, England will be visited and possibly the journey extended to the continent.

J. T. Royal, Supt. Highland Cemetery, Wichita, Kan., sends a model of a hook he uses to raise boxes from the grave when disinterring, or in case a box becomes fast. It is a double hook, one arm, which opens, is hinged a certain distance, (in model somewhat over half way) up the straight bar of the other arm, and a loose ring drops over both arms to secure a tight hold on the object grasped.

Considerable friction seems to have recently developed in the governing board of Forest Hills Cemetery, Boston, which has resulted in several unexpected changes. Mr. John G. Barker, for many years the superintendent, is no longer connected with that cemetery, although we understand strong pressure is being brought to bear to secure a continuance of his services. Mr. Barker will be pleased to hear from his many friends among the superintendents and may be addressed at Horticultural Hall, Boston.

The improved cemetery records, lot books and indexes furnished by the publisher of this paper are now in use at more than one hundred and fifty cemeteries. Nothing is more important in cemetery work than the keeping of the records in such a manner as to insure preserving all of the particulars in regard to every interment, and the system followed in the above mentioned books leaves nothing to be desired in this respect. Descriptive circulars will be mailed on application to R. J. Haight, 334 Dearborn St., Chicago.

#### Received.

Price List, Rules and Regulations of Pine Grove Cemetery, Lynn, Mass.

Rules and Regulations, Mount St. James Cemetery, Watertown, Conn.

From Mr. Theodore A. Leisen, engineer and superintendent, Report of Board of Park Commissioners, Wilmington, Delaware, 1895. This is the first regular report issued and it contains a historical account of the system together with other pertinent information, and is beautifully illustrated with half-tones, wood engravings, and maps.

MOUNT AUBURN. By Frank Foxcroft, copyrighted. Reprinted from the *New England Magazine*. A descriptive pamphlet of the celebrated Mt. Auburn Cemetery, Boston, Mass., beautifully illustrated with a number of prominent monuments and statues and characteristic views of the place.

General Descriptive Catalogue and Garden Guide for the South, of the Southern California Acclimatizing Association, Santa Barbara, Calif. This association has done and is doing splendid work in introducing and acclimatizing new plants. As is stated its work is especially adaptable to the South, but its catalogue also indicates what plants may be used in colder sections of the country.

J. M. Underwood, Secretary and Superintendent, Lakewood Cemetery, Lake City, Minn., writes: "I think you would do well to encourage all cemetery associations to introduce the permanent care feature, and am grateful to PARK AND CEMETERY for calling my attention to it."

#### TESTIMONIALS.

James C. Scorgie, Supt, Mt. Auburn, Cemetery, Boston, says: "I am very glad of the opportunity of returning, if I can, some of the benefits I have received from the reading of your paper."

We take four copies of PARK AND CEMETERY, and value it very highly. Long may you continue in the good work of educating in the line of beautifying and perpetuating the plots made sacred by the interment of loved ones.

*E. B. Henslee, Supt.*

Greenwood Cemetery, Zanesville, O.

Mr. R. J. Haight: I have taken a great interest in extending the circulation of "PARK AND CEMETERY" because it is most worthy of encouragement and support by those whose profession and work cannot be successfully practiced without reading the valuable contributions appearing each month in its columns, and still keeping up with the times. *B. J. Judson, Supt. Agnes Cemetery, Albany, N. Y.*



# PARK AND CEMETERY.

FORMERLY THE MODERN CEMETERY.

A Monthly Journal Devoted to Parks and Cemeteries.

R. J. HAIGHT, Publisher,

334 Dearborn Street, CHICAGO.

Subscription \$1.00 a Year in Advance. Foreign Subscription \$1.50.

VOL. VI. CHICAGO, JULY, 1896. No 5.

## CONTENTS.

EDITORIAL.....	287
TREES AND SHRUBS IN JACKSON PARK, CHICAGO.....	288
ANCIENT BURIAL CUSTOMS.....	288
*SOME NOTABLE MONUMENTS RECENTLY DEDICATED.....	290
*THE HOMEWOOD CEMETERY, PITTSBURGH, PA.....	292
*GARDEN PLANTS, THEIR GEOGRAPHY, IX.....	294
*THE CALIFORNIA UNIVERSITY GARDENS.....	296
*HAMMERED GRANITE.....	298
WATER LILIES—NYMPHÆA SUPERBA.....	299
HUNNISH CEMETERY AT CZIKO.....	299
*VILLAGE ADORNMENT—LEGAL.....	300
PARK NOTES.....	301
CEMETERY NOTES.....	302
CORRESPONDENCE.....	303
PUBLISHERS DEPARTMENT.....	304

\*Illustrated.

WHILE our cemeteries and parks are in certain respects making rapid headway in characteristic excellencies, there are yet many features to be considered before, even in this day, they can be said to be up to date. Among these might be suggested shelters or rest houses, to which should be added means for enjoying the beautiful scenery of the place, which would suggest either altitude of location or of structure. Another, which has been practically entirely neglected, perhaps more so in our cemeteries than in our parks, though in the latter an excuse for the proper thing is the prevailing condition, is toilet accommodations and the accompanying absolutely necessary conveniences properly and attractively arranged. It is strange that so little attention has been paid to this important feature, for a proper distribution of such conveniences would immeasurably increase comfort and the enjoyment of the beauties of the place.

THE park system of Chicago has, generally speaking, been universally admired. Considering the age of the city, there is no question but that the broad and liberal policy which inaugurated its scheme of parks bespoke wise forethought which has been amply justified. That being conceded, there has been, however, a lamentable oversight in the direction of providing for that class of citizens, whose condition, as in every large city, precludes its participation to a fair extent in the larger parks, which for the most part are located well away from the crowded portions of the city. The race for wealth, which has largely come to many of its citizens from real estate holdings, has blinded those in interest to the demands of an enlightened civilization, and Chicago's City Fathers have never been credited with very many humanitarian efforts outside their own importunate needs; so that we find a city of immense area, a large portion of which teems with humanity, the second city in population in the great United States, possessing only so many inter-urban breathing spots as may be counted on the fingers of one hand. Public sentiment in other large cities is demanding that the crowded masses shall be provided with small parks close at home, and immense sums are being expended in the purchase of sites for the purpose. How the neglect of this provision, which should be attended to early in the career of every growing city, is making the work a costly one? But the demand is one that cannot be neglected. In this age, at last, the making of good citizens is acknowledged to lie in the care of the children, and small parks and playgrounds for their recreation and health, are now demanded as a settled policy of city development. And it is not a one-sided policy either. It reacts to the general good: on sanitary grounds it is an excellent remedial agency; on moral grounds its effects can scarcely be comprehended, so broad is its scope. Given a city with an abundance of well cared-for small parks and playgrounds, and it will go without saying, that the moral and physical atmosphere of that place will create a comparison, which applied to less favored spots will assuredly make it odious,



#### Trees and Shrubs in Jackson Park, Chicago.

The permanent planting of Jackson Park and the Midway Plaisance has been underway since the spring of 1895, and last year's work already speaks for itself.

The planting is all done in accordance with the plans of the landscape artists and is under the supervision of Mr. Fred Kanst, who has been head gardener of the South Park system since its organization. That he is familiar with the soil and climate and is in every way a thorough practical man is shown by the excellent success of last seasons planting, amounting to 40,000 trees and shrubs, that now look wonderfully well. The percentage of loss among shrubs has been too small to note and is very low among trees. For instance, so far, only ten trees have died out of the 500 American Elms set out in four rows, one on either side of two drives extending from end to end of the Midway. The greatest mortality is among the oaks, and Mr. Kanst says that if fifty per cent of transplanted oaks live the planter should be content.

This year 80,000 trees and shrubs have been set out in the proportion and locations specified by the Landscape Artist's plans. The trees used include American Elms, Alders and Lindens; English Elms; Pubescent Ash; Box Elder; Sassafras; Flowering Dogwood; Red Bud; Cockspur and Scarlet Thorns; English Hawthorn; Hoptree; Silver, Red, Norway and Mountain Maples; White Willow; Catalpa-Speciosa; White, Chestnut, Burr, Pin, Red and Scarlet Oaks; Canoe Birch and *Betula Lenta*; Poplar, var. *monilifera*, and Oriental Plane trees.

The shrubs specified cover as wide or even a wider field and among them one notes with satisfaction many that abounded in the wild shrubberies that were scattered through the tract now included in Jackson Park. These may of course be depended on to thrive as well as to be in keeping with the original spirit of the place. But no where in the lists (so far as seen) do I find the Wild Crab Apples named. Yet I recall vivid pictures of scenes in the park, while it was still a wild and uncultivated tract, in which the prominent feature of the composition is a picturesque group of Crabs in full flower against a back ground of Burr and scrub Oaks. The frequenter of old Jackson Park in its native state would like to see as many of its native features reproduced or restored as is consistent with cultivated grounds, and one feels that no lake shore landscape near Chicago, can be right without the native crabs. Their fair and fit companion, the wild Rose, is amply represented in the planting, which is good, for it abounded in the same ground. The pretty little Button Bush and elfish Witch Hazel are also there, both old residents of the place as were sever-

al of the Cornuses that are plentifully introduced among the cultivated plantations now being established.

Among the new shrubberies I note *Berberis vulgaris* and *Thunbergi*; *Ligustrum vulgare* and *Ibata*; *Spiræa salicifolia*, *tomentosa*, *Reevsi* and *spulifolia*; *Viburnum opulus*, *acerifolium*, *dentatum* and *prunifolium*; *Cornus sericia* and *stolonifera*; *Syringa vulgaris*; *Lonicera Orientalis* and *Halleana*, (the latter associated with *Rosa Wichuraiana* in nine beds of one hundred plants each, the proportion being seven Honeysuckles to each two creeping roses and all are set three feet apart). Mock Orange; Choke Berry; Bay Berry; *Deutzia Crenata*; *Weigelia rosea*; *Ilex verticillata*, Japan Quince; *Rhodotypos Kerrioides*; *Rosa rugosa*, *multiflora*, *Wichuraiana*, *lucida*, and *nitida*, shrubby Cinquefoil; wild Gooseberry; Indian Currant, Bladder Nut; *Aralia spinosa*; *Rhamnus Catharticus*; Prickly Ash; Bitter Sweet; Shad Bush; *Rhus glabra*, *capallina*, *aromatica* and *typhina*; *Hypericum prolificum*; *Hydrangea paniculata*; and *Forsythia viridissima*.

These are planted by the hundred from two to three feet apart in mixed beds, the combinations and locations being specified and proportioned for the production of given effects in the prospective landscape.

*Fanny Copley Seavey.*

#### Ancient Burial Customs.

In an interesting article in the *Jewish Quarterly Review*, London, England, Mr. A. P. Bender says: That the Jews were not the only Nation of antiquity who had bestowed care upon the purification of their dead prior to interment.

The Syrians washed their dead, and afterwards clothed them in linen vestments. Jacob of Edessa however, explains that the washing of the dead, which the Nestorians regarded as an ordinance of the church, was nowhere commanded, it only became a recognized custom because at first those who died from severe ulcers were washed and anointed with fragrant oil of consecration, and the practice was afterwards extended to all alike. The laity and inferior clergy had their whole bodies washed; monks, nuns, anchorites, and the superior clergy had only the head, hands and feet cleansed.

The Samaritans are prepared for burial by their own friends; the whole body is washed, but especially the head (thrice), mouth, nose, face, ears, both inside and out (all this Mohammedan fashion), and lastly the feet. The Mandæans also have a sacrament of the dying. They pour first hot and then cold water over the head of the dying man, and subsequently array him in the rasta, in which he is to be interred. Dying without this ablution and a tire causes the soul to remain up to the last day



among the Matarta's. When one of the Anseyreehah dies, the body is well soaked, and is washed with warm water. The corpse is then wrapped in a white shroud. Likewise among the Abyssinians, the body is wrapped in a white cotton shroud. It was the custom in Greece that the women should wash and anoint the body, and then clothe it in clean white garments. It was also a rule with the Romans for the body to be bathed in hot water and then anointed. Among the Assyrians and Babylonians, the corpse was wrapped in mats of reed and covered with asphalt; it was clothed in the dress and ornaments that had been worn during life—the woman with her earrings in her ears, her spindle-whorl in her hands; the man with his seal and weapons of bronze or stone; the child with its necklace of shells.

The Jews of ancient times had also a number of valuable articles deposited with them in the grave. Thus, when Hyrcanus opened the sepulchre of David he took out of it 3,000 talents. In like manner, Aristobolus was buried with many ornaments. With regard to the Syrians the Patriarch John complains that costly garments and all kinds of finery were buried with the dead. In Greece, too, many tombs have been found to contain various articles that had been dear or useful to the living. Among the Polynesians it was customary to bury with the dead some article of value; a female would have a cloth mallet laid by her side, whilst her husband would enjoin his friends to bury with him a favorite stone adze; or a beautiful white shell worn by him in the dance. Among various South African tribes, "the ornaments, rings, armlets, tobacco pipes, and articles of apparel worn by the departed are placed in the grave, as well as his broken spear, walking-stick, and other small personal effects." In the case of the Jews, symbols and souvenirs of the calling of the deceased were sometimes suspended from the coffin, modern Jews often deposited in the grave a bag filled with earth (by preference dust of the Holy Land) which is placed under the head of the corpse.

When the dead has been thoroughly prepared for burial he is placed in a coffin in a sleeping posture, the hands and feet being stretched out to their fullest length. The corpse must on no account be squeezed together. The corner of the prayer cloak, of which a fringe was torn off, is left hanging out of the coffin.

There is some uncertainty as to whether the dead were buried in ancient times with or without a coffin.

In early Biblical times there is certainly no mention of a coffin being used for the corpse, with the solitary exception of the case of Joseph (Gen. 1,

26), and his interment in a coffin was no doubt owing to the fact that the Egyptians employed a kind of wooden case which contained the embalmed dead. In the passages in the New Testament bearing upon the subject there is also no trace of such a practice.

In the Testaments of the Twelve Patriarchs, however, it is remarked that they were placed in a coffin prior to burial. With regard to Simeon, it is added that the coffin was of wood which did not decay. But this is, of course, only fanciful.

At the same time the Talmud contains several names for coffins, and the precise instructions which it gives with regard to the manner of interring persons of different status unquestionably points to the fact that a coffin was generally employed to contain the mortal remains in Rabbinic times.

A one day old child (as among the modern Egyptians) is not borne to the grave in a coffin, but in one's arms. A child of thirty days has a miniature coffin that is easy portable. The same rule applies to children under twelve months. A child aged from twelve months to three years is placed in a coffin that can be carried on one's shoulders. A child that has completed the age of three, or advanced beyond it, is regarded as an adult, and conveyed to the grave on a bier.

It appears that a stone used to be placed on the coffin of persons excommunicated by the Jews. Thus we are told that Akabya ben Mahalallel died under ban, and the Beth-Din cast stones upon his coffin. R. Jehuda says, however, that it was Elizer ben Chanoch who was "banned." When he died a stone was laid on his coffin by order of the Beth Din. Hence it is to be inferred that one throws stones upon the coffin of one who has been excommunicated and died under ban. The custom was however, abolished by the rabbis of the Middle Ages. It was possibly based on the case of Achan, who, having been as it were excommunicated for having taken of a devoted thing, had a great heap of stones raised over him (Josh. vii., 26). A similar custom prevails among the Arabs. *The Sunnyside.*

A number of projects are on foot to commemorate the poet Burns on the centenary of his death. A contemporary describes one of the proposed memorials as follows: The centenary of Robert Burns's death is going to be celebrated in Scotland by the laying of a corner-stone of a sensible monument. Around a tower which is to contain relics of Burns will be erected a large number of cottages designed to shelter deserving old people who through ill luck have failed in their struggle with the world. The tower and cottages overlook the fields where Burns plowed up the daisy and wrote his poems,



### Some Notable Monuments Recently Dedicated.

There was unveiled in Lincoln Park, Chicago, on Saturday afternoon, June 6, a statue of one of the most noted men of our early statehood, and one to whom, notwithstanding his patriotism and power, comparatively few memorials have been erected—Benjamin Franklin. The event was made one to be recorded, and the work of the man and his great

second statue to Franklin erected by a newspaper man, the first being that in Washington given to that city by the proprietor of the *Washington Post*.

The accompanying illustration, from a photograph taken of the statue as it stands in the park, requires little to describe it. It is simple, yet expressive. The figure is taken from authentic portraits and established data; the pedestal is graceful in its excellent proportions. Altogether it may be pronounced a splendid addition to Chicago's rapidly growing list of good statuary.

The bronze figure stands 9 feet 6 inches in height, and was modelled by Richard H. Parks, of Chicago, and cast by the American Bronze Co. The pedestal is of Barre granite, fine hammered throughout. The total height of the pedestal is thirteen feet and the bottom base is twelve feet square.

Illustrated on the next page is the bronze equestrian statue of General William Henry Harrison, which was unveiled at Cincinnati, O., on Decoration day. It shows General Harrison in the regular military dress of his time, wearing his chapeau and with drawn sword, in the act of reviewing his troops on the eve of a battle.

The bronze horse and rider measure from the base to the top of chapeau fourteen feet in height. The pedestal, which is of Barre granite, measures thirteen feet from the ground to the plinth of the statue, and the bottom base is 22 ft. by 15 ft. 6 in. On the south side of the pedestal, in sunken letters, is the name "William Henry Harrison" and on the north side "Ohio's First President."

A competition for this work was inaugurated in 1886, and the time for receiving models

for the monument was finally set for September 10th., 1887. Premiums were offered for the first three models chosen by the committee, and after due consideration of all the proposals tendered, the work was finally awarded to Louis F. Rebisso, sculptor, who also executed the commission for the



STATUE OF BENJAMIN FRANKLIN, LINCOLN PARK, CHICAGO.

ability were set forth from eloquent lips and will go down as present day estimates of the position of the man in his country's early development.

The monument was the gift of Joseph Medill, of the *Chicago Tribune* to the city of Chicago, and in this connection it may be stated that it is the



equestrian statue of General Grant in Lincoln Park, Chicago.

Considerable delay occurred in the carrying out of the project, both before the competition in the sculptor's work and since; for on May 21, 1892, the Commission was notified that the bronze casting was completed and ready for shipment from the works of M. H. Mossman, Chicopee, Mass. It was not until this year that arrangements were fully completed for the erection of the work and it was unveiled in Garfield Park amid considerable enthusiasm. It is the only monument of the kind in the city of Cincinnati.

Imposing ceremonies attended the unveiling of the Garfield Memorial in Fairmount Park, Philadelphia. This monument, which has been in the hands of the sculptor, St. Gaudens, for some years, was eagerly anticipated, and besides being an important work in itself is associated with a grave occasion in our country's history. The Fairmount Park Art Association, under whose auspices it was carried out, made a great public ceremony of the unveiling and is to be congratulated upon its work throughout. The monument consists of a classic granite pedestal surmounted by a colossal bronze bust of James A. Garfield. An ideal bronze figure stands in front of the pedestal.

In Washington, the bronze equestrian statue of General Hancock, modelled by Ellicott, was unveiled in May, the dedication address being made by President Cleveland. The statue shows General Hancock as he appeared on the morning of the last day at Gettysburg, sitting firmly in the saddle and slightly checking his impatient horse. It surmounts a fine pedestal of Jonesboro red granite, and while being a work creditable to the sculptor, is an interesting addition to the public monuments of Washington.

Two bronze equestrian statues were also dedicated on the Gettysburg battlefield,—monuments to Generals George B. Meade, and W. S. Hancock.

The Meade statue was modelled by Mr. H. K. Bush-Brown of Newburgh, N. Y., and is a good composition, quiet but alert in pose. The horse is finely modeled and represented in good working

condition, with an air of great intelligence. The General is sitting quietly overlooking the battlefield, with the bridle dropped on the saddle. In his right hand he holds a field glass, which is lightly resting on the pommel of the saddle, and in his left he carries his hat—a point deemed by some critics derogatory to the work. The portrait of General Meade is boldly rendered with quiet dignified expression.

The statue of General Winfield S. Hancock, by Edwin F. Elwell, of New York, is another commanding battlefield monument. The General sits his horse firmly and appears, by the extended right



THE HARRISON MONUMENT, CINCINNATI, OHIO.

arm to be giving directions as to certain movements of his men. The granite pedestal is designed on classic lines and is simple in outline.

On the whole the monuments dedicated this year display a marked advance in artistic excellence, and it may be safely assumed, that with the broader ideas on art and its relation to public memorials we have seen the last days of that absolute mediocrity which has characterized the work of the past. Public memorials should stand for permanent memorials, and can only do so when they perpetuate the best efforts of the time.



### The Homewood Cemetery, Pittsburgh, Pa.

Special features of improvement frequently characterise certain of our cemeteries, or perhaps it might be better stated, that to certain lines of improvement more particular attention is paid by some cemetery associations than by others, and so glancing at the illustrations given herewith of the Homewood Cemetery of Pittsburgh, Pa., the character of the buildings strike one as having had particular attention paid to their construction, both as regards design, appropriateness and permanence.

This cemetery was established in the year 1878 and comprises some 176 acres of land, which in-



"THE LODGE." W. H. C. CO.

cludes a lake having an area of one and a half acres.

The character of the land, as might be inferred from its locality, is varied in elevation, and the cemetery is traversed by three and a half miles of road, all of which are macadamized. The tract is laid out in fifteen sections. The lots vary in area between ten by fifteen feet, and sixty by sixty feet, and lot lines are shown by corner posts set level with the ground. Grass paths graded with the section give access to the lots.

The single grave portion of the cemetery is laid out in ten divisions of ten lots each, and the aim in regard to restricting is to secure as great a uniformity as possible.

As may be observed the lawn plan is strictly enforced, and to add to the landscape effects, certain reservations are set apart



VIEW OF LAKE.

for ornamental plantings. Mounds over graves are restricted to a height of four inches, and may be finished oval or square.

Care is also exercised with regard to monuments, such restrictions being enforced as will insure freedom from the many unfortunate incongruities which are so conspicuous in many of our cemeteries. Designs and foundation sheets must be submitted for approval before construction is proceeded with.

The greenhouse is an important function of the Homewood Cemetery, five houses comprising the plant. City water distributed through a pipe and hydrant system affords ample water facilities.

The accompanying illustrations give the general character of the buildings, etc.

The Receiving Vault, which is constructed of Barre granite, is twenty seven feet, six inches wide by twenty two feet deep and sixteen feet high. It contains thirty two large catacombs for bodies and thirty two recesses for urns. It has solid bronze gates and doors, and completed, cost some ten thousand dollars.

The entrance at Homewood Avenue, which also



HOMWOOD AVENUE ENTRANCE.



includes the bridge over the ravine, cost over thirty thousand dollars.

The Lodge, which is the Secretary's residence, and which appears in two of the illustrations herewith, is constructed of Ohio stone, and was built at a cost of eight thousand dollars.

The stone office building cost twelve thousand dollars.

It is evident that in providing buildings of such character and cost, the management had no temporary views in mind. Besides being constructed of materials to ensure permanence, the designs selected display decided taste, and a disposition on the part of those in control to spare no ex-



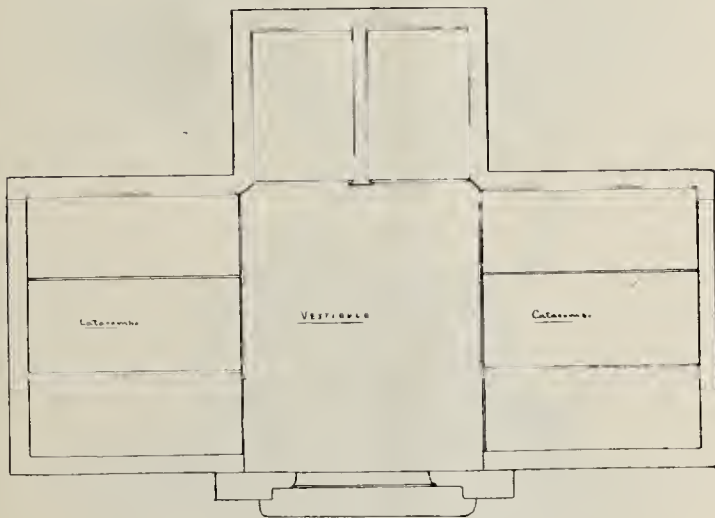
RECEIVING VAULT.

Natural conditions have much to do with the design and selection of accessories in cemetery work, and it is upon the ability to harmonize and correlate the several factors that gives greater or less value to the results.

The number of interments to date amount to 7047, irregularly distributed over the past years.

The cemetery employs an average of eighteen men the year round.

The tract was originally laid out by Mr. George Fortune. The superintendent now in charge of the cemetery is Mr. David Woods, who for many years has been identified with the Association of American Cemetery Superintendents.



FLOOR PLAN OF RECEIVING VAULT.

pense necessary to secure appropriate structures, both in regard to appearance and finish. The most recent ideas connected with convenient cemetery offices have been taken advantage of, to the end that business may be facilitated as well as the cemetery itself made more attractive thereby.

The question of harmonious landscape effects is of every day discussion, but the relation of the cemetery buildings to the landscape is not so often considered; yet that is a most important point, and in fact buildings mar or make a vista, just as far as they are considered in relation to their surroundings.

In the case of Homewood the substantial yet picturesque buildings, the hilly nature of the ground, the plantings for landscape effect and the beautiful lawns as the prevailing feature of the lawn plan of cemetery design, are all elements, which combined in harmonious relations lend themselves to the creating of an attractive and beautiful cemetery.



OFFICE BUILDING.



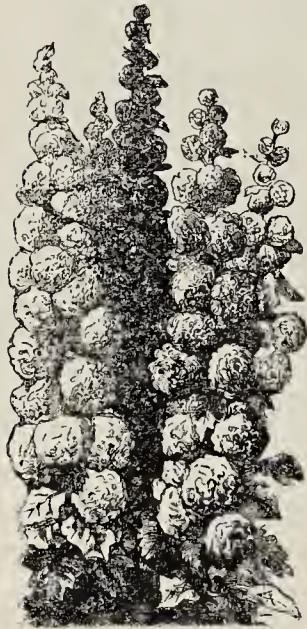
## Garden Plants,—Their Geography. IX.

## MALVALES.

## THE MALVA, HIBISCUS, AND TILIA ALLIANCE.

This extensive group of trees, shrubs and herbs, has a wide distribution in nearly all regions of the world except the very coldest. There are 12 tribes, 167 genera, and 2,000 species, with a multitude of varieties. It is a useful group, notable as producing a number of valuable fibres chief of which is cotton. As garden plants many are eminently ornamental both in tropical and temperate climates. Several are handsome marsh or sub-aquatic herbs, and a few are esculents.

*Althæa* is credited with 15 species distributed over the temperate regions of the world. The most



ALTHÆA ROSEA.

familiar and worthy species in our gardens being the *A. rosea*, "hollyhock," with its large number of single and double varieties. This plant is a biennial in our climate, or perennial in more favorable ones. It shows a disposition to naturalize in some seasons in Central New Jersey, but again in others it seems to be confined to the warmest and best drained spots in old gardens or cemeteries. It is a native of the Levant. The other species are rarely seen, but often worth growing.

*Lavatera* has 21 species similarly distributed over the warm temperate regions and one from Australia. *L. arborea* is found wild sometimes on the rocky cliffs of the south coast of England, but is quite impatient of frost when grown in the rich soil of a garden, where it often reaches a height of 12 or 15 feet, it has rosy-purple flowers some two inches across and there is a variegated form. *L. trimestris* is an annual from Spain with pink or white flowers.

*Malva* has 16 species, in temperate regions and widely distributed, but adventive in the United States. *M. moschata*, British, *M. Mauritiana* African, and others are known in gardens. There are perennials and annuals among



MALVA MOSCHATA ALBA.

them and all are summer flowers.

*Callirhoe* with 7 species, *Sidalcea* with 8 species, and *Napæa* with 1 species are all North American.

*Sida* has 90 species distributed generally over the warmer parts of the world. *S. spinosa* is a roadside weed in New Jersey, but adventive from the South.



ABUTILON, Garden Variety.

*Abutilon* has 80 species distributed over the warmer parts of the world, but again New Jersey claims one wanderer from India, *A. avicennæ*. Very many garden varieties are in cultivation, they are useful both as summer and winter blooming plants and are hardy in California. They thrive well planted out in the northern gardens during summer, but are rather difficult to lift until they



HIBISCUS ROSA—SINENSIS FULGENS.

become large and attain a good sized compact ball of roots, when with a little attention to shading &c. they are easy. I would here remark that attention should be given to the raising of hybrids between the annual and biennial species of these tribes. It is entirely practicable. Up to quite recent times seed pods of *Hibiscus rosa-sinensis* were unknown in herbaria, and this induced me to produce them 18 years ago. I had failed in a previous year with their own pollen, but succeeded with pollen of *Hibiscus Cameroni*, etc. The seeds were sown, and grew, when the plants passed



out of my hands, and very likely were neglected.

*Malva viscus* has 6 species, all Mexican and Central American. They are scarlet flowered shrubs for the most part, and are so far as our garden species go, mostly winter flowering.

*Hibiscus* has 180 species. They are well distributed over the temperate and warm regions, a few being



HIBISCUS MOSCHEUTOS.

tropical. Some are trees, but they are mostly shrubs, and perennial and annual herbs. *H. Trionum* is an annual well known and found in all the warmer parts of the old world, and in Australia; it has naturalized in America. *H. moscheutos* is our "swamp mallow," there are several varieties, some of which have naturalized in S. Europe. They make handsome herbaceous bushes on a lawn, flowering in August. *H. Syriacus*, "Shrubby Hibiscus," shows a decided disposition to become wild in New Jersey where the competition of the native trees or shrubs is not too strong. There are many handsome varieties, and they are capable of better use. They should be pruned hard in spring or after the leaves have fallen, in this way they can



HIBISCUS TRIONUM.

be kept compact, well furnished with foliage to the ground, and they will flower handsomely and abundantly. The variegated leaved kinds make good ornamental hedges. Several of the tropical kinds of *H. rosa-sinensis* are used in the summer garden, but are impatient of severe frost, in Florida however, the grow up again from the roots. *H. elatus* is the Cuba-Bast tree.

*Gosscypium* "Cotton" has 32 species, all natives

of warm regions. The seeds if sown at the same time as lima beans will make good flowering plants North.

There are a number of other genera in the foregoing affinities which contain annual and other species of great beauty which are rarely or never met with in gardens. Among these many be mentioned Malope, Kitaibelia, Palava, Malvastrum, Cristaria, Modiola, the shrubby Plagianthus from Australasia, the Kydias which are white flowered small trees from the lower Himalayas, and a few of the shrubby Brazilian Pavonias. The Thespesias also it might be expected would flower out doors during our summers if plunged in their tubs, but they become good sized trees, and can only be indulged in where there is ample warm winter storage.

Beyond these are several tropical genera containing plants of great interest to be noted for experiment in our extreme Southern climates. *Adansonia* is the "baobab," a tree of greatest girth in the world and used in Africa as a mausoleum. *Bombax* in 27 species are the "Silk Cottons," they are natives of the tropics of Asia, Africa and America, and make stuffing for the most luxurious beds in existence. *Durio* has 7 species in the Malay Islands, one of which yields a fruit of great repute.

*Thecobroma* is a genus of 15 species all natives of the warm parts of the West Indies and Central and South America. *T. cacao* is a small tree of 12 or



TILIA ARGENTEA.



LEAF OF LIME TREE INFESTED BY PHYTOPTUS TILIAE.

15 feet high from whose seeds the various kinds of chocolate and cocoa are produced. Its area of profitable production is limited for the best grades; it is exacting as to soil and climate, and those who own good plantations have one of the most certain sources of income known to the cultivator, for the supply is never equal to the demand. This of course is a great stimulus to adulteration. The plants come into profitable bearing in about 5 years, yielding about 1 lb. per tree, and on good soil they endure for a half century or more. It costs from \$250



to \$300 per acre to bring them into bearing, and generally an acre will contain from 700 to 800 trees worth in bearing from 75 cts. to \$1.00 per tree. The cost of preparing the product averages 7 to 8 cents per lb.

*Sterculia* has 85 often very similar species described; they are mostly from warm regions, but a few pass beyond the tropics, and if my memory serves, one of these stood out at Washington several years. Further south *S. platanifolia* is quite satisfactory, and no doubt several of the East Indian kinds would succeed below the severe frost line. *Cheiros-temon* is the singular Mexican "hand flower" growing to a fair sized tree. *Fremontia Californica*, named after a distinguished explorer who was badly rewarded by his government, is unfortunately difficult on the Atlantic Slope, but does better in parts of Southern Europe. It is a handsome shrub. *Dom-beyas*, *Mahernias* and some few others of the alliance are growing in greenhouse collections.

*Grewia* is a large genus of some 80 species of shrubs and trees from the warm regions of both hemispheres. *G. parviflora* is in one or two of the hardy botanical collections, and has flowered about mid-summer; it is from China, and not showy, but several plants of ordinary character in themselves are often useful to heighten the effect of others.

*Corchorus Capsularis* is the "jute" so largely grown in India for the Dundee Mills. There are 30 species, of little ornamental value, found in the warm parts of the world, *C. pilolobus* and *C. siliquosus* being found in Texas, southwards.

*Tilia* has 8 species and a very large number of varieties, from temperate Europe, Asia and North America. Among the most ornamental kinds, *T. Europæa rubra*, *T. aurea* and *T. pendula* may be mentioned. *T. argentea* is a handsome silvery leaved species, and it also has a variety with drooping branches, called *T. argentea orbicularis* of recent introduction. Others have been referred to *T. petiolaris*.

*Tilias* are often affected by two or three species of mites which form "finger galls" on the leaves as shown in the cut, but they can scarcely be said to do much harm. These trees are known as "Lindens" or "Limes" in Europe, and as "bass woods" here. They produce the bast matting so well known to gardeners and prepared chiefly in Russia.

A very large number of the plants of this alliance yield stem or seed fibres. Many are use-

ful timber trees, usually with light soft wood. The famous Massoolah boats of Madras, are built of *Berrya* wood. Several *grewias* and others have edible fruits, and a mucilaginous or acidulous quality is quite common among them.

Trenton N. J.

James MacPherson.

#### The California University Gardens.

The grounds of the California State University at Berkeley, facing the Golden Gate, are situated in a very equable and attractive climate, where the range of vegetation is unusually great. Many prominent botanists and horticulturists, visiting the place, have expressed their surprise at the variety of species to be seen here. We have had notable visitors from Russia, Germany, France, England, Japan, and other countries, as well as from various parts of the United States.

A rather rapid review of some of the trees and plants which can be seen in a walk across the ten or twelve acres best planted along the slopes of the hills, will illustrate the extent of this interesting climatic range. All the plants named are in first rate health, and all are growing close together, under the same conditions, and receiving the same outdoor treatment, namely, a fair amount of cultivation, but no irrigation. The typical native growths are oaks (*Quercus agrifolia*) together with laurels (*Umbellularia Californica*), buckeyes (*Aesculus Californica*), the Toyon, or red-berry (*Heteromeles arbutifolia*) and lesser growths. All these belong to the outer slopes of the Coast Range, within the region of sufficient rainfall, but not within the Redwood district. We are really on a climatic border-line between the Redwood country, and the Oak country, of the Coast Range. We have no Madrone (*Arbutus Menziesii*) and no Manzanitas (*Arctostaphylos*,) but outposts of the Redwood



GLIMPSE OF THE ECONOMIC GARDEN, BERKELEY, CAL.





DEODAR, IN THE GROUNDS, BERKELEY, CAL.

were within the historic period, five miles south of us in the San Lorenzo canons, while one of the largest Oak groves in California occupied the sandy shores of Oakland and Alameda. The Berkeley slope fronts the Golden Gate, and behind it steep mountains rise to the height of about 1500 feet. Sheltered here from extremes of heat and cold, almost everything that is planted appears to thrive. The visitor sees nearly all the deciduous fruit trees, such as apples, pears, plums, cherries and apricots.

Dwarf Japanese oranges, a large collection of Olives,—probably the most complete in America—, a collection of Mulberries, Japanese Persimmons, Chestnuts, Almonds and many other fruit and nut-bearing trees illustrate the range in this direction.

One of the very rare nut trees is the *Guevina Avellana*, of Chili, one of the most beautiful of trees, in flower or in fruit. Another very attractive nut tree is the *Macadamia ternata* or Queensland nut, a superb, broad-leaved evergreen. The first of these is worth testing in the Southern States, where it is likely to prove hardy; the *Macadamia* will hardly thrive out side of California and Florida.

In comparatively close proximity to the fruit and nut trees I have mentioned, are fine specimens of *Chionanthus Virginica*, the Fringe Tree of the Atlantic States; of *Sorbus aucuparia* and *S. Americana*; of *Carya alba*; of *Salisburia adiantifolia* of *Ceratonia siliqua*, *Prosopis juliflora*, *Pistacia terebinthus* and *P. vera*. Trees from every part of the world are represented along Strawberry Creek.

Here is the Argan tree of the Barbary States (*Argania sideroxylon*); the *Brachychiton acerifolium* of Australia; the *Rhus vernicifera*, *R. succeda-*

*nca* and *Camphora officinalis* of Japan; the *Ruitzia fragrans* and *Bellota Meirsii* of Chili.

In making up this collection during the past twenty years, the object of Professor Hilgard, the head of the Department of Agriculture, and his many assistants, has been to bring together representative species from all such climatic regions as offered plants of possible practical value to California, rather than to create a complete botanical garden, which will be developed in due time on a larger scale than is possible at Berkeley. When the last complete list was published, about 500 species in 80 natural orders were represented in the plantation catalogue. This list

has been steadily increased as opportunity offered, and there are always new trees and plants in the nurseries not yet planted out. It would be fair to estimate that 1000 species of woody plants could be listed on the grounds.

Besides these miscellaneous plantations, the Agricultural Department has an orchard, a collection of species and varieties of *Vitis*, a garden of medicinal and economic plants, and a botanical garden, all at Berkeley. In other parts of California are four Experiment sub-stations of considerable size, well-equipped and officered, also two forestry stations, and a private viticultural station. Considerable collections of vines and trees are being made at these points not alone for vineyards, and orchard work, but also as the beginnings of arboretums.

Charles H. Shinn.

VEGETATION.—Fragility or force, softness and strength, in all degrees and aspects; unerring uprightness, as of temple pillars, or undivided wandering of feeble tendrils on the ground; mighty resistances of rigid arm and limb to the storms of ages, or wavings to and fro with faintest pulse of summer streamlet. Roots cleaving the strength of rock, or binding the transience of the sand; crests basking in sunshine of the desert, or hiding by dripping spring and lightless cave; foliage far tossing in entangled fields beneath every wave of ocean—clothing with variegated, everlasting films, the peaks of the trackless mountains, or ministering at cottage doors to every gentlest passion and simplest joy of humanity.—The foregoing is an extract from John Ruskin's writings, full of the eloquence of that master of the English language.



**Hammered Granite.**

The most casual observer cannot fail to have noticed the steadily increasing use of axed or fine hammered work, particularly for the better class of monuments erected in recent years. When marble began to give place to granite for monumental purposes, the people seemed glad of an opportunity of having some dark material to take the place of the too common white marble, and for many years polished granite, especially of the darker varieties, met with favor and was in constant demand.

The imported red granite as well as the darker colored Maine and Massachusetts granites were susceptible of a very high polish, and this was considered the proper finish for monuments for a long time. With the development of the granite industry many varieties of light colored granites were introduced and much of it was for a time, polished in order to give the contrast that was considered necessary to secure legible inscriptions and give life to the general appearance of the work. Gradually, however, the demand for something different became apparent, and light grey and white granites grew in popularity, which led to the use of hammered work that soon made a place for itself, and to-day many of the finest examples of the monumental art in our cemeteries are void of any polish whatever. The introduction of Romanesque designs as an ornamental feature of monuments has

greatly served to demonstrate the possibilities of many of the finer grained granites for securing artistic effects in carvings and to emphasize the beauty of plain surfaces. The contrast of light and shade to be had from polished surfaces no



THE ORSELL COOK MONUMENT, LAKE VIEW CEMETERY, JAMESTOWN, N. Y.

darker granites, is not so essential in this style of ornamentation. This style of finish is necessarily expensive, as it is only seen to advantage when the best of twelve cut work is used.

The accompanying illustration of the Orsell Cook monument is a good example of such work. The fine hammered surfaces of this pleasing design gives a softness to the texture that can be had in no other way.

The monument is made of light Barre granite, it stands in Lakeview cemetery, Jamestown, N. Y., and is the work of Harrison Granite Co., Barre, Vt



**Water Lilies.—*Nymphæa Superba*.**

The hardy water lily, *Nymphæa Superba*, is a garden hybrid, and originated with a most enthusiastic fish culturist. Speaking of his experience with this splendid water plant, Mr. Geo. B. Moulder, of Smith's Grove, Ky., says:

'Never before has any Water Lily advanced so decidedly towards perfection, as it comprises not only the good qualities of both its parents, but a great amount of excellence peculiarly its own. I first saw it growing in 1891, in the pond of the originator. Having had long experience with aquatics, I was at once impressed with the belief that it was a new and valuable acquisition, and now, after four years of rigid test, I have found it even superior to what was at first claimed for it, proving not only the champion in size, but also in vigor, beauty and freedom of all hardy *Nymphæas*, the leaves not uncommonly growing 23 inches in diameter, while we have often measured flowers that were 12 inches from tip to tip. The petals are long, narrow and pointed, of the purest snow white, and open well back, displaying with striking effect the myriads of long, golden-yellow stamens which dance around the center of the flower. As age advances the stamens change to brown, and finally to almost black, giving the flower quite a different appearance from those just opening. The leaves on the upper side are rich tan green and underneath light maroon. When they float on the water their edges turn up after the manner of the Victorias, but where the plants are allowed to assume a natural growth, becoming somewhat crowded, both leaves and flowers rise up on stiff, rank stalks a foot or more above the water. This unique habit adds wonderfully to the majestic appearance of the plant, and pre-eminently characterizes it from all other Water Lilies. In vigor it excels all other varieties in cultivation. It is amphibious, so to speak, luxuriating regardless of drouth or floods. The past summer, we had some plants growing in a tank where, during the drouth of June and July, the water became very low, in places, exposing the roots. The first of August a heavy rain filled the tank, completely submerging the Lilies under six feet of water, and, to our great surprise, in less than three days both leaves and flowers were on the surface, fresh and vigorous as ever. It does fairly well in tubs, but is pre-eminently a pond plant. No water Lily will flourish in swift water, but this is excellent for coves and slow streams. For absorbing malarial poisons, so far it has proved one of the best, if not the very best. The originator declares that there has been no form of malaria in his neighborhood since the advent of *N. Superba*, though previously such diseases were common, and his neighbors had occasion to com-

plain of his pond as the source of these troubles. Many other testimonials equally forcible confirm the truth of this statement, and if the plant had no other virtues, it is worth its cost to experiment with in that particular, especially in pond-afflicted districts. In fish culture it has already proved invaluable and each new experiment confirms every claim, and brightens its record. Taken altogether, it is the largest, most useful and desirable Water Lily in existence, and should be in every park, stream, pond and mud-hole in America."

**Hunnish Cemetery at Cziko.**

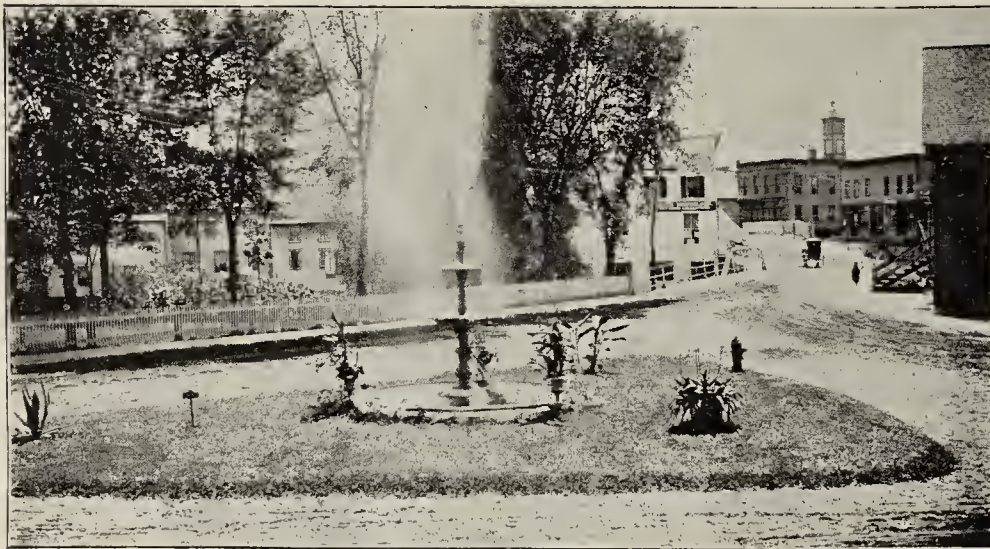
At Cziko, in the comitat of Tolna, a little on the western bank of the Danube, some seventy miles south of Buda Pesth, and at the eastern extremity of that district known to the Romans as Pannonia, there was discovered something over a year ago by the parish priest of Apar, Deacon Moritz Wosinsky, some five hundred graves, forming a burying ground of the much dreaded Huns, who, about the middle of the fifth century, overran Europe under their great leader, Attila. The little graveyard is situated in a beautiful spot where two valleys meet; and runs up the slope of a hill to a deep cleft, which separates the consecrated ground from the surrounding fields. Owing, evidently, to the warlike character of this once obscure tribe, who by the way, are said to have first crossed the banks of the Tanais, the boundary of their ancient Sarmatia, in pursuit of an ox stung by a gad fly, by far the greater number of the skeletons are those of women, children and the aged. In some cases man and wife lie close together in the same grave, in others a mother lies with her child across her breast; in all cases without coffins, their heads pointing to the west, their feet to the east. The horses when found, lie in an opposite direction, saddled and fully equipped. Beside the men are usually found knives, arrow heads, three edged javelins, lance points and axes. Their belts are mounted in silver and bronze, very beautifully decorated. Very often coins of the fourth century are found in the left hands, with flints (silex and jasper) and steel. The women's love of personal adornment is amply testified by the ear rings, often as large as bracelets, hat ornaments, fibulæ and bracelets of gold and silver, amber, bronze and glass, found in their graves; as also small knives, spindle whorls ("spinnwirtel"), and eating vessels ornamented by wavy lines. Eggs have also been found, in many cases having their shells still unbroken. Among the most interesting discoveries have been styles similar to those used by the Romans for writing on wax tablets, showing the Huns to have been less barbarous than usually supposed. In one instance, even, a lady (probably



the wife of a chieftain), whose earrings are of massive gold, was found holding a beautifully ornamented stylus of silver. The skeleton of a woman measures 6 feet 3 inches in length; two bronze earrings were found in the ears; the iron buckle of a belt had fallen between the crests of the iliac bones; in the right hand was a small iron knife, in the left a swivel.—*Reliquary and Illustrated Archæologist.*

#### Village Adornment.

Now that improvement societies are rapidly organizing in our smaller towns and villages for the purpose, as the name implies, of stimulating efforts to secure better conditions about the streets and public places, it is opportune to present ideas that have become facts, and so emphasize suggestions for adaptation elsewhere.



PUBLIC FOUNTAIN, LEBANON, N. H.

The accompanying illustration gives a view in Lebanon, N. H., where by the exertions of Miss Mary L. Storrs, of Albany, N. Y., a native of Lebanon, a triangular spot at the junction of two thoroughfares, used for a common dumping ground, has been turned into a beauty spot and the pride of the village. Money was raised by subscription to purchase a fountain, grade and improve the plot, and the unsightly ground has become transformed into a neat little park, reflecting its condition upon its surroundings and thus justifying to the fullest extent the labor and sacrifice involved in the inauguration and development of the plan of improvement, and bestowing credit upon all concerned.

Many an unsightly scar on the face of, perhaps, an otherwise interesting location, could be so removed and the benefit of such an improvement be immediately appreciated. In this particular line of work the outlay need not be prohibitory, and the fountain offers an economical means of making considerable display at moderate cost. Besides, as has so often

been suggested in these columns, such benefactions may wisely form memorials of departed citizens, just as appropriately, and far more beneficially located than within the confines of the cemetery.

#### Legal.

##### TITLE BY ADVERSE POSSESSION.

The supreme court of Alabama holds, in the case of *Bonham v. Loeb*, that proof that the complainant's grandfather, husband and children were buried in a certain lot; that so long as she lived conveniently near she visited it frequently and kept it in very good condition; that after she moved away she left it in charge of another lady, who testified that she went to the spot frequently, and gave it the best attention she could; and that more than ten years back one of the firm who bought

the property said that the graveyard would never be troubled, will not establish title by adverse possession.

##### ONE BURIAL PERMIT SUFFICIENT IN PENNSYLVANIA.

A law has been passed in Pennsylvania providing that whenever a cemetery or burial ground is located partly within the corporate limits of two or more municipalities, a burial permit issued by the proper authority of either of said municipalities shall be a sufficient warrant for the interment of the body mentioned in said permit in part of said cemetery.

One of the most remarkable monuments in this country is in San Luis Obispo, Southern California. A great rock rises 150 feet above the plain of Carissa, and in the distance looks rugged and forbidding. It has on its eastern side an opening 25 feet broad, which leads into an inner temple or court, with level floor 225 feet long and 125 feet broad at its widest part. The ceiling is 60 to 100 feet high. This great natural cathedral is a wonder to geologists, but it is more wonderful to archaeologists. It was evidently used by prehistoric men as a temple of worship or a capitol of government. On the walls are paintings in red, white and black, doubtless having a meaning. There are figures representing fields, suns, forts, spears, men, and animals. The colors are apparently as bright as when laid on. The wonder was discovered by Franciscan missionaries more than one hundred years ago, and there has been no change in its appearance since. When or by whom the walls were decorated no one knows.



PARK NOTES.

A fountain is to be erected between the two parks of Franklin, Pa., in memory of Judge A. G. Egbert. The proposed work will be 25 feet high with about the same diameter at base. The cost will be nearly \$2000.

\* \* \*

A Woman's Park and Improvement Association is a feature of Pueblo, Colo. It has so zealously and actively agitated various improvements in the city that the demand for said improvements has become general and a park system is now receiving particular attention.

\* \* \*

Mrs. Sarah E. Deming, of Terre Haute, Ind., on June 4th, donated eighty acres of ground east of the city for park purposes provided Ohio Street is opened across the Evansville and Terre Haute railroad tract within two years. The question of opening the street is now in the Supreme Court.

\* \* \*

Fountains are very appropriate features of ornament to brighten some of the neglected spots and corners in our villages and their adoption for such purposes are becoming more common. Oneida, N. Y., is one of the towns adding to its attractiveness in this line, two bronze fountains being among its additions.

\* \* \*

Chester, Pa., is in a fair way to prosecute park improvements. An ordinance has been passed creating a board of park commissioners, and the hundred acres of land now owned by the city for park purposes, and which has been secured by the liberality of certain citizens, will soon witness operations designed to fit them for the people's pleasure and recreation.

\* \* \*

Possibilities of extravagance loom up in connection with park improvements in our large cities, but permanence costs money and permanence with artistic features costs more money. But \$40,000 for a marble band stand for Humboldt Park, Chicago, leads to the conclusion that some band stands come high, and marble for a band stand also seems straining hard for costly effect.

\* \* \*

Mrs. Augusta C. Pease, widow, last month notified the governor of the Connecticut Society of Sons of Colonial Wars, Hartford, Conn., that the price of the piece of land at the junction of Charter Oak Avenue and Charter Oak Place, desired for the site of a memorial for the Charter Oak, which once stood there, would be "nothing at all" except the legal consideration of "one dollar." Her husband had often expressed a wish that the spot might be used for the purpose and on that consideration she was glad to make the gift.

\* \* \*

Food for thought is liberally supplied in the fact that the Commissioners of Charities of Kings county, resolved last month to improve the fifty acres of ground about the Almshouse in Brooklyn, N. Y. They employed some of the prisoners from the jail and with this help and that of the male members of the county's poor, a transformation scene is being enacted which could be imitated to advantage at similar establishments throughout the country: No unsightly spots should be permitted about public institutions, for whatever purpose existing. Incalculable good results from a little natural beauty judiciously disposed about such establishments.

Great improvement is taking place in Chattanooga, Tenn. Among other features a system of tree planting has been inaugurated in which the park commissioners are being generally assisted by the citizens. The idea is that the same variety of trees shall be planted along each street so that uniformity and consequently a better appearance shall result. The commissioners will suggest suitable varieties, so that trees best adapted for street purposes, both as to nature of growth, shape and adaptability may be secured. The question of the removal of fences in the residence streets is being agitated, and will be carried out when protection can be assured. Altogether an era of improvement has set in and the co-operation of the citizens with the park commissioners promises most beneficial results.

\* \* \*

If Mr. Falconer, the superintendent of Schenley Park, Pittsburgh, Pa., is allowed a free hand, that park will be one of the loveliest, from a botanical standpoint as well as otherwise, in the country. From the results of his work at Dosoris, Long Island, the country residence of Mr. Chas. A. Dana, of the *New York Sun*, this may be taken for granted. His intention appears to be to follow a botanical arrangement in filling the park with plantlife, but naturally modified from book form according to the natural conditions prevailing and the requirements of the several situations. It is to be hoped that we may sooner or later find such a public park completed according to the design and intention of an authority, untrammelled by the petty restrictions so common and detrimental in their effects in our public service.

\* \* \*

Blue Mountain Park, established about the Croydon mountains, not far from Newport, N. H., by the late Austin Corbin, comprises some 26,000 acres of land, wild but picturesque, admirably adapted to the purpose intended, a wild game preserve. Some thirty miles of wire mesh fence, eight and a half feet high, surround the estate, while trees of suitable variety are being planted along the wire to eventually form a live fence and keep the untamed stock within bonds. The fencing was completed in 1890. Entrances are to be found at convenient locations at each of which comfortable gate keepers lodges are constructed. Some forty or more miles of streams and lakelets traverse the property, abounding in fish. The principal animals now domiciled on the tract are buffalo, moose, elk, deer and wild boars, imported from Germany, besides various game birds. The inclosure contains the largest variety of wild birds and beasts of any similar preserve in the country.

\* \* \*

The commissioners of the South Park system, Chicago, will take charge of the Lake Front Park, the great park project now being vigorously prosecuted. This will place the work in competent hands, create confidence in the tax payers, and if their previous efforts promise anything, will carry out the work to the end, that practically right at the heart of the city of Chicago, one of the most beautiful parks in existence, with all the accessories of water expanse, and landscape, will still further build up the great city. It is now proposed to construct a water side boulevard, connecting Jackson Park with the Lake Front Park, giving a lake shore drive to the south side, several miles long. The park system of Chicago, is developing in the larger way in line with the city's prosperity, but unfortunately thus far little attention has been paid to that even broader necessity, the small park. Perhaps no city in the world is more seriously lacking in this feature of urban economy than Chicago. But it must come and that speedily, and the many will have to provide heavily for the neglect of the few of years ago, when the cost would have been comparatively light to the few.



## CEMETERY NOTES.

Previous to adjournment and under suspension of the rules, Congress passed a bill: "Opening National Cemeteries to the burial of army nurses.

\* \* \*

The Russian-American residents of Minneapolis, Minn., and vicinity, are taking steps to secure a plot of ground with a view to establishing a cemetery for their own use.

\* \* \*

At the recent meeting of the stockholders of the Montgomery Cemetery Company, Norristown, Pa., three women directors were elected, the first time in the history of the company.

\* \* \*

In Crown Hill Cemetery, Indianapolis, Ind., during the last official year there had been 1,253 interments, making a total of 23,575, of which 16,445 are in lots, 6,285 in single graves and 785 are soldiers.

\* \* \*

The propriety of providing shelter houses in our cemeteries is a growing idea. The trustees of cemeteries of Malden, Mass., in their last report suggested that they be provided with funds to build a suitable structure as a shelter from sun and rain and a place of rest. Here is an opportunity for an appropriate memorial, backed up by official suggestion.

\* \* \*

The annual report of Woodlawn Cemetery, New York, states that in 1895 2,105 interments were made bringing up the total to date, 48,561. There were erected 206 monuments at an estimated cost of \$129,825 and nine mausoleums at \$129,000. At request of lot owners arbor vite hedges have been removed from 524 lots leaving only 27 thus enclosed, and no hedges or borders will be permitted in the future.

\* \* \*

Evergreen Cemetery, Portland, Me., is remodelling its main entrance, in order to carry out the idea of cheerfulness and attractiveness in approaches to the cemetery. When completed the work will be a pattern for other such undertakings. Very few noteworthy additions have been made in mortuary monuments in this cemetery the past two or three years, but there is the prospect of a fine monument to be erected next spring, the foundations of which will be built the coming fall.

\* \* \*

The cemetery trustees of Lansing, Mich., have instructed the city treasurer who holds a number of overdue notes on cemetery lots, to notify the signers of the notes that unless the same are immediately taken up, the bodies interred in such lots will be removed and reinterred in the Potters Field and the lots declared vacant. The action does not contemplate persecuting those placed in unfortunate circumstances, but to enforce payment from those well able to meet their obligations, but who have neglected their duty. A similar course was resorted to some years ago with good results.

\* \* \*

For a few years past an innovation in funeral customs has been steadily gaining ground in New York and vicinity; it is that of holding funeral services at night. It serves two ends conspicuously, that of economy, and also of enabling friends to attend without serious loss of time. It is also in line with the change in regard to pall bearers, the large majority of funerals being conducted without this formality. Night funerals are held both at the home and at the church; if at the church, after the

service the body is taken either to the home or to the undertakers for the night, and in the morning the simplest service is carried out and the body taken to the grave without further service. Many funerals are now held at the undertaking establishments, which offer certain advantages as to space and economy.

\* \* \*

The report of the board of Trustees of the new cemetery, Lake Side, Erie, Pa., covering the period for the year ending May 1, 1896, has just been issued. The cemetery was organized in April 1895 and charter granted the same month. The work of improvement was commenced August 10, 1895 and continued until Nov. 10. to be resumed April 1, of this year and continued therefrom. During this time 12 acres were graded, 5½ acres seeded, 3 circles seeded, 3,385 feet of drains and tiles laid, and 4973 feet of roads graded and nearly completed. A large number of trees and shrubs were planted out, a nursery for young stock established, and work so advanced that the company is about ready for interments and sale of lots. The cemetery is beautifully located, with frontage on the shore of Lake Erie, of about ½ mile, with an average height of bank thereon of over 50 feet.

\* \* \*

Commendable progress is being made in the St. John, N. B. Rural Cemetery, to bring it under the modern ideas of cemetery management. The task is a difficult one, old notions to be displaced, new ideas to be inculcated, funds to be provided and much tact and business effort expended to bring about satisfactory results in the shortest possible time. In the above case progressive officials made it a point to seriously study the best examples in the nearest states and to follow it up by active endeavor. Thirty six lots have been placed under perpetual care, and in 1895 454 were under annual care. The number of interments in 1895 were 279. Many improvements have been carried out on the property. An important suggestion is made in the report just issued relative to the care of the lots and monuments of the "old worthies" of the locality whose burial places are neglected, but who served their generation well. Generous citizens are entreated to subscribe towards putting these neglected spots in order and for their perpetual care.

\* \* \*

Some interesting suggestions are conveyed in the nineteenth annual report of the Magnolia Cemetery, Charleston, S. C. A large amount of improvement is being carried out, and an innovation in cemetery improvement, is that of creating a park out of a portion of the land too low for burial purposes. This is to be planted out and provided with seats and will form a beautiful resting spot. Some 10,000 interments have been made in the cemetery since its opening, and 2200 lots sold. The total receipts from sales of lots have been \$173,732. Twenty per cent has been funded from the sale of lots, which now amounts to \$35,564.57. Only from 3 to 5 per cent has been paid in dividends to the stockholders, the balance having all been expended in improving the property. The perpetual care fund now amounts to \$24,216.50. Magnolia cemetery has suffered considerably from natural causes the past few years. In his report, the president, Mr. Geo. W. Williams says: "I am sorry to report several hundred private lots in Magnolia which are totally neglected. Expensive monuments, iron fences and brick enclosures, which were shaken down by the earthquake of '86 and by the storms of '93 and '94, remain uncared for and are covered with briars, bushes and squalid growth, thus marring the beauty of the Cemetery. The trustees are so dissatisfied at the condition of the uncared for lots that at a recent meeting they gave the superintendent of the Cemetery authority to put the abandoned lots in order at the expense of the owners. Five thousand dollars are needed for repairs due to the storms and earthquake. This will be expended as rapidly as realized.



The reports of the Allegheny Cemetery, Allegheny, Pa., show total receipts \$68,356.80 and total expenses \$30,277.50. The receipts included interest for invested capital \$22,684.53. The amount added to endowment fund was \$7,907.41, the actual net cost of keeping the cemetery for the year was \$19,420.25. The perpetual care fund now amounts to \$32,710.42, and the total endowment fund, or invested capital, from which the interest is derived, exclusive of the above for perpetual care, is \$456,090.38. The greenhouses have a little more than paid expenses after providing all the plants used on the grounds. The aggregate sale of lots amount to \$27,477.50, making the total number to date 5,138. There were 401 memorials erected at an estimated cost of \$82,000. The total number of interments are 38,717. Considerable work has been done in grading new sections and building stables and gardener's house. Owing to the heavy grades in the cemetery much expense is incurred in repairs of roads, etc., the past year the use of limestone screenings was experimented with, and with so much success that this material will be adopted for all new roadways.

\* \* \*

The plan adopted by the management of the Flushing Cemetery, Flushing, Long Island, of securing a perpetual care fund on the installment plan has worked well. The necessity of perpetual care was acknowledged in 1888, since which an extra charge of ten cents per square foot was added to price of lots. The charge was made small to encourage the lot owners to take advantage of it, whatever balance being required was assumed to be paid out of the general fund for the care of the entire grounds. Every effort has been made to induce purchasers previous to above date to take advantage of the perpetual care plan and with gratifying success, 64 lots having been added in 1895. During the past year and in order to make perpetual care more popular, and to place it within the reach of all, an installment plan covering a period of ten years has been established, care to commence with payment of first installment, and the scheme is quite popular. A large addition was made to the property last year, which is being rapidly prepared for sale under a design and rules embodying the latest ideas both on landscape gardening and the lawn plan of cemetery practice.

\* \* \*

The supreme court of Missouri has declared that, the charter amendment adopted by Kansas City, at a special election last summer, providing for the condemnation of lands for parks and boulevards, is constitutional, and all proceedings by the park board under the amendments are legal. This means much to the city and will enable the Board to raise funds for the long delayed park improvements.

\* \* \*

An effort at floral architecture is that of a reproduction of the peristyle of the World's Fair at Garfield Park, Chicago. It is sixty feet long, twenty-five feet to the top of the gateway, and fifteen to the top of the colonnade, but there is one row of columns to the colonnade. The framework of bark is made in skeleton form to leave room for the earth for the growing plants. The dirt is held in place by a wire netting, and in the apertures red and yellow alternanthera are set closely together. Echeveria are also extensively employed. Over all vines run riot. Where the quadriga stood in the original a mammoth century plant is used, and four others are placed on the colonnade to relieve its outlines.

\* \* \*

The City Parks Association of Philadelphia who commenced years ago to obtain for the city open spaces, large or small, whereon trees may be planted, gardens laid out, and play grounds for children of the poorer classes, held its annual meeting in May. The Association has done much good and is continuing

its activity to meet the increasing demands for small parks, caused by the growth of the city. The report says: "It is hoped that Councils, coming to fully appreciate the value of the Association's friendly assistance, will continue to aid in the future as in the past. More open spaces are needed in the crowded districts, and it is desirable that properties may be taken fronting upon either of the rivers, affording easy access to the pleasure of the waters." Some 30 small parks, ranging in acreage between a fraction of an acre and thirty acres have been acquired by the city since 1888. Play grounds for children is a special feature of the association's work and one highly to be commended and encouraged.

\* \* \*

In the pamphlet recently issued by this Muncy Cemetery, Muncy, Pa., there are a number of pertinent suggestions offered to its lot holders. Speaking of Perpetual Care, it says: "The Problem of Perpetual Care now demands serious consideration. The cemetery may be beautifully laid out and embellished, the lots and avenues may now be well kept, and there may be room for interments for hundreds of years, but how long will vigilant superintendence preserve the grounds and memorials from diapidation? Protection is the paramount question to everyone who has friends buried in a cemetery. But what assurance has the lot-holder that the graves of himself and kindred will long be cared for after all have gone to their last sleep? What has he done or what will he do to stay the ravages of time, and to restrain the hand of lingering barbarism? Can he reasonably expect that posterity will do what he himself neglects to do."

## Correspondence.

FRANKLIN, PA., June 29, 1896.

*Editor Park and Cemetery,*

DEAR SIR: I was very much encouraged to hear from Brother Stone, in the June number of the PARK AND CEMETERY, I am always inspired by such correspondence. I know however that we do not do our duty in this line as we should, but writing is something that can be put off, and how often it is done. We all must envy Friend Stone's lilly pond; how he must enjoy it, and the work, surely it is a pleasant task to care for them, for Solomon in all his glory, did not compare in beauty.

This has been the most pleasant summer with our com-munity for many years. No late frosts; warm and pleasant showers of rain; with health and comfort and an abundance of fruit and flowers to bless us. Rose bushes were beautiful, having no bugs for the first time in many years. Our Yuccas are in their prime at present and do very well here; wintering without covering, in fact all plants have done well this year.

In regard to Sunday funerals, they are much less frequent than in former years; we have very few, and nearly all are private. Much good can be done in this line as well as others by enlisting the undertakers in the good work. Heads are seldom uncovered at the services except during the benediction. I would like to know if all the Superintendents throw earth in the grave during the services, at the pronouncing of the words "Earth to Earth, Ashes to Ashes."

I hope to be able to meet you all at St. Louis, in September. By the way, why not have the next meeting in Franklin, and try the hospitality and kindness of the good people of this part of Pennsylvania. Think of it, we will give you a pleasant reception. I wish to return thanks to PARK AND CEMETERY for its help in our work, and the many good things we get from that paper. I think I would fail in my work many times without it. Supt., Franklin, Pa.

*C. D. Phipps.*



**The Boston Park Report.**

The annual report of the Board of Commissioners of the park system of the city of Boston, Mass., contains a large amount of exceedingly interesting matter, as might be inferred from the vast sums of money which have been expended on the parks and the progressive methods adopted in their development and care. Some of the figures are instructive. The Fens, taken up in 1879, has cost to date of report \$2,634,516.89. It contains over 115 acres and has over ten and a half miles of drives and walks. Jamaica Park, with 120 acres, has 7 miles of drives and walks and has cost, since 1892, \$955,059.09. The Arnold Arboretum and Bussey Park, the former dating from 1882, contains 223 acres and 11 miles of drives and walks, cost \$306,760.80. Franklin Park, with 527 acres, and some 32 miles of walks and drives has cost \$3,341,094.40. The park system comprises 2,162 acres and the total expenditures have been \$13,309,240.18. Suggestive paragraphs are the following: With regard to the influence of public parks on the neighboring real estate, no recent figures have been made. In 1890 the board published a statement of the increase in value of the Back Bay lands since the establishment of the park. By this table it will be found that the land alone was trebled in value in the thirteen years, while the valuation of land in the rest of the city during the same period increased only eighteen per cent.

"The increased taxes on this land, without including the buildings erected, aggregated over two million dollars—a sum more than sufficient to pay the entire cost of the improvement at that time. The increased taxes on new buildings erected on these lands yielded one and a half millions of revenue."

This has been the experience in all places where carried out under proper conditions. Property immediately enhances in value and a residence neighborhood is built up beneficial to the community.

**Association of American Cemetery Superintendents.**

O. C. SIMONDS, "Graceland,"  
Chicago, President  
G. W. CREESY, "Harmony Grove,"  
Salem, Mass., Vice-President.  
F. EURICH, Woodlawn, Toledo, O.,  
Secretary and Treasurer.

The Tenth Annual Convention will be held at St. Louis, September, 15, 16 and 17.

**Publisher's Department.**

NOTICE TO SUBSCRIBERS. If this notice is marked with a blue pencil it indicates that your subscription to PARK AND CEMETERY has expired and a renewal of same is solicited.

Park Commissioners and Cemetery trustees are requested to send us copies of their reports.

Photographs and descriptive sketches of interesting features in parks and cemeteries are solicited from our readers.

PARK AND CEMETERY wants the names of every park and cemetery official or employee who would be likely to be interested in this paper. To the many subscribers who have sent in such list of names, we return our thanks. There are many more that we should hear from.

Subscribers are again reminded that we want brief notes on any feature of park or cemetery work that will be of general interest. PARK AND CEMETERY is the only publication of its class and earnestly solicits the co-operation of subscribers in making it a help to all identified with such work.

**RECEIVED.**

Report of the Trustees of Cemeteries of the City of Walden, Mass., for the year ending December 31, 1895.

Annual report to the Lot Owners for the year 1895 with Rules, Regulations, etc., Woodlawn Cemetery, New York. This report is illustrated with a number of full page photographs.

Presidents and Superintendents reports of the Allegheny Cemetery, Allegheny, Pa.

A very attractive little illustrated pamphlet of Flushing Cemetery, Flushing, Long Island, giving its history, description and information concerning its perpetual care and other funds for improvement and perpetuity.

Report of the Directors of Saint John Rural Cemetery, Saint John, N. B.

Lectures, Laws, Papers, Pictures, Pointers. Interstate Park, Dalles of the

St. Croix, Taylor's Falls, Minn., St. Croix Falls, Wis., Compiled by Geo. H. Hazzard, Commissioner Interstate Park. This is a compilation of the lectures and other work arranged and carried out under the direction of Mr. Geo. H. Hazzard, and is in line with his energetic efforts to push the enterprise to fruition. It forms a pamphlet of some 100 pages, interestingly and copiously illustrated.

Annual report to the Lot proprietors for the year ending May 1, 1896, together with Rules, Regulations, etc., the Lake Side Cemetery, Erie, Pa., Illustrated.

St. Agnes Cemetery, Albany, N. Y., Charter, Rules and Regulations; Catalogue of Lot Owners, etc., revised to June 1, 1896.

City of Boston, Department of Parks. Twenty-first annual report of the Board of Commissioners for the year ending January 31, 1896. The report of 123 pages is beautifully illustrated with full page half tone of various features of the park system.

History, Condition, Rules, Regulations, etc., of the Muncy Cemetery, at Muncy, Pa. The pamphlet is illustrated with half-tone portraits of the successive presidents of the Cemetery Association.

**TESTIMONIALS.**

James C. Scorgie, Supt, Mt. Auburn, Cemetery, Boston, says: "I am very glad of the opportunity of returning, if I can, some of the benefits I have received from the reading of your paper."

We take four copies of PARK AND CEMETERY, and value it very highly. Long may you continue in the good work of educating in the line of beautifying and perpetuating the plots made sacred by the interment of loved ones.

*E. B. Henslee, Supt.*

Greenwood Cemetery, Zanesville, O.

Mr. R. J. Haight: I have taken a great interest in extending the circulation of "PARK AND CEMETERY" because it is most worthy of encouragement and support by those whose profession and work cannot be successfully practiced without reading the valuable contributions appearing each month in its columns, and still keeping up with the times. *B. J. Judson, Supt. Agnes Cemetery, Albany, N. Y.*

J. M. Underwood, Secretary and Superintendent, Lakewood Cemetery, Lake City, Minn., writes: "I think you would do well to encourage all cemetery associations to introduce the permanent care feature, and am grateful to PARK AND CEMETERY for calling my attention to it."



# PARK AND CEMETERY.

FORMERLY THE MODERN CEMETERY.

A Monthly Journal Devoted to Parks and Cemeteries.

R. J. HAIGHT, Publisher,  
334 Dearborn Street, CHICAGO.

Subscription \$1.00 a Year in Advance. Foreign Subscription \$1.50.

VOL. VI. CHICAGO, AUGUST, 1896. No 6

## CONTENTS.

EDITORIAL .....	305
THE FROST PICTURES OF THE ALPS.....	306
*ENLARGEMENT OF LINCOLN PARK, CHICAGO.....	307
*A VISIT TO WOODLAWN CEMETERY, NEW YORK.....	308
THE CONVENTION OF CEMETERY SUPT'S, ST. LOUIS	309
*UNVEILING GARFIELD MEMORIAL, PHILADELPHIA	310
*OSBORNE, THE MARINE RESIDENCE OF QUEEN.	
VICTORIA.....	311
FLOWERS AT THE MISSOURI BOTANICAL GARDEN	
ST. LOUIS.....	312
TURKISH CEMETERIES.....	313
*GARDEN PLANTS, THEIR GEOGRAPHY, X.....	314
*A TRANSFORMATION SCENE.....	315
*THE MILWAUKEE, WIS., PARK SYSTEM.....	316
LEGAL.....	318
PARK NOTES.....	319
CEMETERY NOTES.....	320
CORRESPONDENCE.....	321
PUBLISHERS DEPARTMENT.....	322

\*Illustrated.

THE approaching tenth annual convention of the Association of American Cemetery Superintendents, which is to be held in St. Louis, September 15, 16, 17, promises to be of more than usual interest, and should bring together a large number of its membership, and many new members from western cemeteries. There can be no question as to the amount of good that has been rendered to cemetery interests over the country by the association; it can be observed wherever a member has charge of a cemetery and its influence has gone out far and wide. It follows then that a greater interest should be taken in its work by cemetery associations. To a limited extent this is done, and several superintendents attend the convention at the expense of their corporations. But the practice should be general and enough such business good sense should be displayed as to promote in every possible way the acquirement of experience and

knowledge by so important an official as the superintendent, and no better way could be pointed out than the annual interchange of practical ideas such as are brought out at these conventions. A number of interesting papers are promised, but beyond this, St. Louis has one of the finest botanical gardens in the world, with special advantages for disseminating its experience, under the provisions of the late Mr. Shaw, its munificent donor, and the annual gathering in connection with this institution also provided for by the will of Mr. Shaw, has been arranged to take place during the time the Superintendents are in session. Taken in conjunction, it may be expected that a most entertaining and instructive time will be passed fraught with untold good to its participants.

THE modern idea of cemetery practice, involving as it does the consistent regulation of all details to the end that a burial park may be secured rather than a burying ground, makes the supervision of all matters affecting the care and appearance of the grounds, by the proper officials of the association, absolutely necessary. This applies with equal importance both to the lot and the memorials proposed to be erected thereon. And the wisdom of such comparative arbitrariness is easily apparent. One has only to visit our cemeteries generally to see what has been the effect of past methods, and to become satisfied that the only way to procure satisfactory results in view of advancing civilization, is to enforce such rules and regulations as will tend to secure the desired end. Much more attention is now being paid to the subject of monuments and their foundations, and cemetery officials are very wisely giving more care to this important feature of our cemeteries, strict rules having generally been established, looking to the prevention of duplicates, appropriateness of design, proportion and proper foundations. For some time past more stringent rules have been in force calling upon lot owners to submit all designs for monuments to a properly designated official, such designs to be approved before work is commenced upon them. This is now a rule so generally understood that it is strange to hear of a case where an important monu-



ment has been cut before approval of design had been secured. Yet such an instance is before us involving a large outlay and where the cemetery officials refuse to allow it to be erected. It therefore becomes important that monument dealers should make themselves acquainted with cemetery rules concerning monuments. While primarily it is the lot owners business to see to this, it is none the less that of the dealer, to whom lot owners so often go for advice, to post himself on such matters. He will have the information not only to protect himself, but in connection with his business will be reinforced to help the purchaser with intelligent advice.

**T**HERE is food for thought in the fact that there are so many instances in park and cemetery affairs, where the influence and activity of one individual, have been the main factors in the success of the enterprise. Even under officially constituted governing bodies, it will be generally found that in due course a leading spirit asserts itself, and provided that the obstacles of official red tape and officious interference are not overwhelming, its influence in inspiring enthusiasm and activity, leads to results which otherwise might be very slow in maturing. It is not always that the individual meets with merited reward except in the self satisfaction; rather, oftener, he is misunderstood and criticized for presumption; but in the case of a completed park and cemetery the result is a permanent gratification, well worthy of sustained determination and effort, albeit unseasoned by the grateful acknowledgment of those benefited. Happily there are cases where a grateful public heartily responds so that there is the double reward.

#### The Frost Pictures of the Alps.

Nature is very lavish in her attractiveness, and every season has for certain localities, particular indications of her diverse power. In the Austrian Tyrol, the frost aided by the sun creates some remarkable effects among the highest peaks of the Alps, which form a natural attraction for multitudes of tourists annually. Some of the pictures cover the whole side of a mountain; many are failures, but others are remarkable enough to make amends. The Vienna correspondent of the *Philadelphia Press*, has given an account of these from which the following is taken:

"The native designation of these pictures is 'ausaferungfiguren,' which, liberally translated, means molded designs. They are formed by the melting snows on the peaks of the mountains in May and June. The first cold night after the melting season sets in fixes the thawing snow in all kinds of fantastic designs. Some of these thousands

of designs look like nothing at all, but others assume shapes which are absolutely perfect in outline and formation. The curious part of it is that year after year many of these figures appear in precisely the same spot and in the same proportions. The formations of the mountains over which the thawing snow flows are accountable for this oddity.

"The place from which to view these pictures is the Town of Innsbruck, and from every street and public place in the little city these figures can be seen for weeks at a time. Then, when the first hot wind blows up the mountain peak the pictures melt away, and are seen no more until another year has gone by.

"On the highest peak of what is known as the Arzler Mountain appears the heroic figure of a falconer, attired in the large sleeves and hat of the middle ages. While the falconer is one of the most durable of the snow pictures, that of an angel, which appears just beneath it on the mountain side, melts away more quickly than any of the others, but, when seen immediately upon its formation, it is the most perfect of all. When at its best, the angel seems to be separated from the mountain, and appears, with its spreading wings and extended arms, to be blessing the earth.

"The Herald, with a long trumpet in his hand, looks magnificent in what seems to be a feather-bedded hat and a costume of glistening silver.

The figure of the hunter and the dog can be seen from a great distance, as it is the most colossal of them all. Its great size is brought out clearly by a small hut located quarter way up the mountain. This hut seems not larger than the head of a pin, while the figure looms up with gigantic proportions. It is located on the northeast cliff of the Patscherkopel, and is surprisingly sharp in outline. The figure shows the kneeling hunter, with his pipe in his mouth, his knapsack slung over his back, and holding his eager dog. This is one of the latest of the pictures, appearing each year after many of the others have melted away.

The water carrier would, in an American city, be immediately dubbed the "growler rusher." When the figure begins to melt the legs increase in length until they run down the whole mountain side. Then they disappear; next the body melts away and later the head fades out of sight, until finally only the hat remains as a reminder of what was once there.

"Another curious thing about this figure is, that after it has completely disappeared the picture of a dwarf appears in its place. In the dialect of the Tyrol this dwarf is called the "mandl," meaning little man.

"The priest attired in all the glory of his vestments, who seems to be sprinkling the earth with



holy water, appears on the Solstein Mountain. Near this figure is that of the witch, whose flowing robes, outstretched arms, and claw-like hands fill the little children of the district with dismay.

"The knitting woman appears on the shimmering side of Serlas, the prettiest mountain of the group. The first thing to melt away is the stocking, which becomes shorter instead of longer, and it seems as if the old lady were actually at work.

"From Voels, a point on the Arl Mountain Railroad, hundreds of smaller snow pictures can be seen, representing everything of earthly and unearthly character—animals, household articles, devils, serpents, birds; ships, buildings and an endless variety of things."

**Enlargement of Lincoln Park, Chicago.**

The popularity of Lincoln Park, Chicago, and its extended reputation as a recreative resort, make proposed improvement matters of general interest. An exceedingly liberal management on the part of the commissioners has given it so large a patronage, that constant vigilance and foresight are necessary to keep it up to the standard of park excellence which has always marked its aspect and condition.

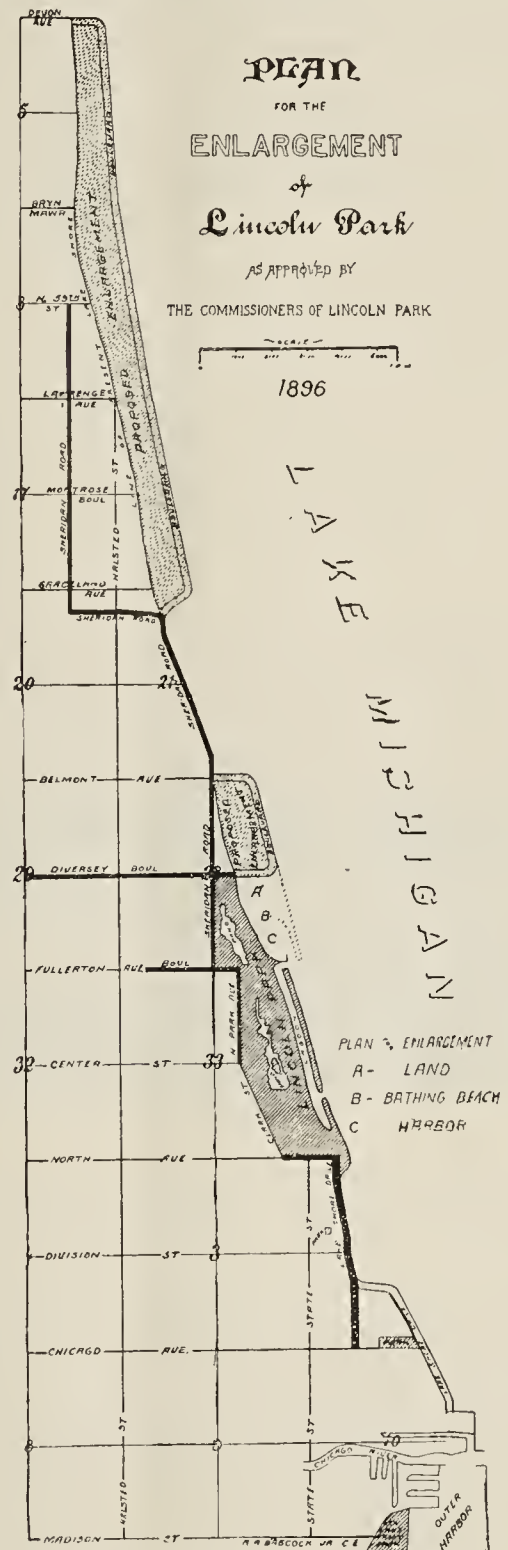
And besides the unremitting care it demands to meet the requirements of the multitude that frequent it, extension and enlargement are matters that call for constant attention. It is confined by limits, too costly to allow of encroachment except on the Lake Michigan side, so that ever feasible project for extension on that side is carefully considered. The commissioners have now adopted a plan of enlargement which is shown on the accompanying map, which together with details is taken from the latest report.

"The shaded portions, indicate parks already established. The dotted portions are extensions, plans for which have been adopted by the Board. That portion east of the park, and between Diversey and Fullerton boulevards, require a plan, none having been adopted. The dotted lines on the map show a proposed plan which may, or may not be adopted. The letters indicate: "A" land; "B" bathing beach; "C" yacht and steam harbor. With these additions, Lincoln Park will have somewhere near 1200 acres, exclusive of boulevards.

In regard to the improvement of the older portions of the park, which in certain respects have been improved as it were piecemeal, the report says:

"At many points, the Park needs remodeling in order to bring about homogeneity and coherence of design. However, this would not be a work of great expense, and might be accomplished gradually. A plan should be adopted and all work and changes, from year to year, be made to conform

to it. In any plan that may be adopted, a systematic policy of carrying the walks under the drives by means of artistic tunnels, or over them by means of rustic foot bridges, should be employed. This would really increase the capacity of the Park for accomodating crowds by preventing congestion at



drive and walk intersections. In addition, it would enhance personal safety, comfort and the pleasure of driving. If, instead of presenting statues, of which this Park has already enough, public-spirited citizens and societies would contribute structures of this sort, they would aid in solving an important problem of Park improvement."



### A Visit to Woodlawn Cemetery, New York.

One year ago I had the pleasure of visiting Woodlawn Cemetery, New York, and carried my camera with me.

On leaving the train the first view to greet my eyes was the one shown in photo No. 1. This is the best point of observation, and is the one everybody sees before entering the cemetery, after leaving the train; as in all landscape, there are many points of view, yet only a few or perhaps only one point where the grandest effects can be observed and the ideas of the artist properly appreciated.

Of the many visitors on this occasion nearly every one stopped here to take more than a passing glance at the beautiful picture that lay before them. The gentle sloping terrace that disappears beneath the water's edge, the unpretentious fountain sending up its delightful spray, seeming to try to cool the warm atmosphere. The group of evergreens with the back-ground of weepers and other deciduous trees; the

water that lays about the middle of the cemetery. Were I called upon to name it, I should say "Mirror Lake." I walked around it more than once, viewing it from all points, and at last finding my ideal picture, I turned to see if a policeman was near enough to say "Keep off the grass." Seeing none, I arranged my camera for a "quick shot," and stole down the gentle slope until almost at the water's edge. There I stood lost in thought, almost enchanted with the scene that lay before me, forgetting my first intention of taking a "snap" and making a hasty retreat before being ordered off the grass. No comments of mine would add any-



VIEW NO. 1.

thing to the beauty of this stolen view. I need only remark that one who is capable of taking the rough and undeveloped piece of landscape and embellish it in the way this has been done, is as much an artist as the painter or sculptor, for here nature's products are arranged into a living picture for all to admire, with nature's mirror to double and intensify the beauty of the scene.

*Sid. J. Hare.*



VIEW NO. 2.

open lawn with the bright design, emblematic of rest, all go to make a handsome and impressive picture.

On entering the gate I stopped at the office to ask permission to carry my camera with me, and to take such views as I might desire; my request was granted. Delighted to have this permission I hurried on. My knowledge of the limited stock of films on hand, caused me to study carefully each picture before taking a "snap" and many that I desired were passed by.

Of the several views taken, each showed care and forethought of the artist in planting and arranging, and deserve to be reproduced for the benefit of those who have not had the pleasure of viewing the original.

Being a great admirer of water and landscape, I send my choice picture No. 2, a beautiful piece of

the beauty of the scene.

The custom of wearing button-hole bouquets is so well established on the other side of the Atlantic, that according to *The Queen*: So seriously has the city of London taken the custom of button-hole bouquets worn by stock-brokers that it actually has given the women who sell flowers recognition. The flower girls, as they are all gallantly called, are permitted by the regulations to set down their baskets and sell their flowers around the iron railings opposite the Royal Exchange. They are among the most respected stallholders in the city. They are uniformly polite, as they may well be, since they may be said to be on speaking terms with all the youth and gallantry of Threadneedle and Throgmorton streets, and they are very skilled in the making of boutonnières.



**The Convention of Cemetery Superintendents at St. Louis.**

This meeting to be held on September 15th, 16th and 17th, will be the tenth annual convention of The Association of American Cemetery Superintendents, and I again desire to urge all Superintendents who can do so to attend.

The object of the Association is to benefit cemeteries rather than Cemetery Superintendents. All Cemetery Associations, therefore, that desire to keep up with the times should send a representative to St. Louis on the days mentioned above. There will be papers and discussions on the management and improvement of Cemeteries. Let me ask once more that members of the Association bring photographs with them. We can learn about cemeteries by visiting them better than in any other way. Next to visiting a cemetery a photograph gives the best idea; and next to photographs, descriptions.

The coming meeting being the tenth of the Association I think it would be well to review the work of past years. If each member, as the roll is called at our first session, would read a selection of one or more paragraphs taken from papers of former meetings or other good articles that have appeared in THE MODERN CEMETERY or PARK AND CEMETERY, it would make the meeting more interesting and help all to get acquainted.

It has always been our aim to make each meeting better than any that has preceded it. Let each member do all he can to make the convention a success.

*O. C. Simonds, President.*

\* \* \*

PROGRAM.

The following is the program of the tenth annual convention of the Association of American Cemetery Superintendents, to be held at the Planter's Hotel, St. Louis, Mo., Sept. 15, 16, 17, 1896

The officers for 1896 are : O. C. Simonds, President, Grace-land, Chicago, Ill. Geo. W. Creesy, Vice-President, Harmony Grove, Salem, Mass. Frank Eurich, Secretary-Treasurer, Woodlawn, Toledo, Ohio.

Executive Committee—Matthew P. Brazill, Calvary, St. Louis, Mo.; R. D. Boyce, Oakwood, Geneseo, Ill.; S. W. Rubee, Riverside, Marshalltown, Iowa.

SEPTEMBER 15, FORENOON.

- Meeting called to order, 9 a. m.
- Reception of new members and roll call.
- Address of Welcome—Mayor Wallbridge.
- President's Address.
- Secretary and Treasurer's Report.
- Communications.
- Informal discussion.
- Recess for dinner.

AFTERNOON.

Visiting Bellefontaine and Calvary Cemeteries.

EVENING MEETING, 8 P. M.

- Selections to be read by members, on call of President.
- Paper. Review of Richmond meeting.—C. W. Hamill.

Paper. Life and Works of John J. Smith, George E. Painter.

Question box.

SEPTEMBER 16, FORENOON.

- Meeting called to order, 9 a. m.
- Roll call.
- Address by Hon. A. Graham Frost.
- Paper. The Cemetery as a work of Art.—Mrs. Fanny Copley Seavey.
- Paper. Roads in Cemeteries where Macadam is too Expensive.—S. W. Rubee.
- Paper. Advantages of nurseries and greenhouses in Cemeteries.—John Reid.
- Appointment of Committees.
- Nomination of Officers.
- Recess for dinner.

AFTERNOON.

Visiting Forest Park and Tower Grove Park.

EVENING.

Banquet tendered by the Missouri Botanical Garden at the Mercantile Club.

SEPTEMBER 17, FORENOON.

- Meeting called to order, 9 a. m.
- Address by Professor J. B. Johnson.
- Paper. Education of lot owners.—Matthew P. Brazill.
- Paper. A Plea for the Perpetual Care of Cemeteries.—B. D. Judson.
- Paper. Fertilizers.—D. Woods.
- Report of Committees.
- Election and installment of officers.
- Recess for dinner.

AFTERNOON.

Visiting Missouri Botanical Garden. Lunch on grounds of Director.

EVENING.

- Meeting called to order 8 p. m.
- Paper. Benefits from attending the meetings of our Association.—J. R. Hooper.
- Paper. Drainage.—H. F. Torrey.
- Miscellaneous new business.
- Adjournment.

Maps of business part of St. Louis, noting railroads from Union Station to Planter's Hotel and other points of importance will be mailed with printed programmes, etc., to address of members.

All members attending convention are expected to engage rooms at Planter's Hotel, and to notify Chairman of Executive Committee if they intend attending convention, and how many ladies will be in the party, so that we can arrange for accommodation.

Invitations to banquet will be distributed in convention parlor.

An officer of the Street Railway Company is always in front of the Union Station to direct visitors to the proper street cars.

Any information will be furnished promptly by Matthew P. Brazill, Chairman Ex. Com., Calvary Cemetery, St. Louis, Mo.



**Unveiling of the Garfield Memorial, Philadelphia; by  
The Fairmount Park Art Association.**

As the sun saw the dawn in the far west, carrying with it the kaleidoscope views of individuals, villages, boroughs, cities and states, having done honor to the memory of their dead, the dead that honored their own graves first by the soul responding spontaneity that made the clutch on rifle butt and sword hilt, a pleasure rather than pain, and both sides right in the expression of its resentment to accept a wrong or insult a right, a score of workmen under the superintendence of a competent landscape gardener, were putting the finishing touches to the statue of the martyred President who stands in the centre of a natural amphitheatre on the east river bridge about half way between the light-house and Girard Avenue bridge.

As will be seen from our reproduction, the background was well chosen by the Fairmount Park Art Association, forming as it were, a draping composed of copper beach, silver maple, larch and Norwegian Pine, giving tone and color to the component bronze and granite of the monument. Nor is this all, since to practically describe that which perforce must be omitted from the illustration, the monument faces the river, which in this instance has been further embellished with the additional dignity of fine granite steps, 21 feet, thus forming a landing place, flanked by classic columns, giving water parties an opportunity to land and inspect this work.

The presentation of the statue by the President of the Board of Trustees of the Fairmount Park Art Association, and its acceptance by the Park Commissioners was followed by the unveiling which happily was performed by the son of ex-President Garfield, now of Chicago. The ceremonies were carried out in the evening of May 30, with land and water processions, and with magnificent electric and pyrotechnic displays.

A glance at the illustration will show the bust of the late President Garfield in bronze, surmounting a pedestal of granite relieved by an ogee cornice and dentals with a well proportioned architrave and frieze, supported by four fluted columns with Ionic capitals. Midway stands an heroic figure, Columbia, coped and draped, bearing the shield and holding in the right hand the emblems of peace and war [the palm and sword] with a panel backing the figure with wreath above, this being entirely of bronze. On the face of the shield is the sign of the eagle "E Pluribus Unum."

**JAMES ABRAM  
GARFIELD,  
PRESIDENT OF THE  
UNITED STATES.  
MDCCCLXXX.**



GARFIELD MEMORIAL, FAIRMOUNT PARK, PHILADELPHIA.

The sub-base is 3 feet 6 inches deep and 5 feet in width with a moulded panel and base 18 feet square. The statue and pedestal costing \$20,000, was designed by Sculptor St. Gaudens, who has given us a simple but life-like bust, instead of a foreign and theatrical figure, thus filling the space with a memorial chaste in expression and harmonious in design. The casting was made by the Henry Bonnard Bronze Co., New York.



**Osborne, The Marine Residence of Queen Victoria.**

Osborne House, near Cowes, Isle of Wight, England, is famous as the marine residence of the Queen of England. It is splendidly situated on an elevated site, the grounds sloping gradually to the sea. It is situated on the north western side of the Isle of Wight. The Solent, as the waters of the



ocean are called, which separate it from the mainland, is perhaps some seven miles wide at this point. On the opposite shore is the mainland with Southampton in view, and to the right, Portsmouth, and Spithead, the anchorage ground for some of England's war ships at all times.

While the plantings at Osborne do not show such gigantic specimens of trees as many places do, being of more recent date, there are some exceedingly fine specimens there of many choice evergreens. For instance imagine the beauty of *Retinospora obtusa*, 30 feet high, by 40 feet wide; *Picea Nordmanniana*, 40 feet; *Pinus insignis*, 50 feet; *Picea cephalonica*, 40 feet; Cedar of Lebanon, 40 feet, and *Cupressus Lambutiana*, 50 feet. These are not uncommon heights but all of these specimens were apparently in their prime and were a nice treat to one like myself viewing them last summer.

The Portugal laurel, *Cerasus Lusitanicus* would prove hardy in this country in sheltered places, just as the *Laurus nobilis* does at Washington. In the Isle of Wight, and elsewhere in England, it is a charming sight in midsummer, for then it is in full flower. The one I saw at Osborne, was a model specimen, some 20 feet high, by as many wide and as full of its white flowers as it could be.

The grounds descend so rapidly from the house to the sea that a terrace surrounds it on that side. Besides the beautiful sea view from the terrace, the walls afford room for the training of many a nice tree, shrub or vine along them. Some of the dark masses shown in the picture are the *Magnolia gran-*

*diflora*, which, trained fan-shaped, as they are, display their large, handsome shining leaves to great advantage. At the time I saw them June 29, they were beautifully in flower. This fine tree is hardy from Philadelphia, southward.

The balustrade to the terrace was banked with *Wistarias*, *Jasminum officinale*, *Myrtus communis*, *Ceanothus dentatus* and other species; golden leaved *Jasminum nudiflorum*, the common lemon thriving nicely out of doors. *Garrya elliptica* and many another nice shrub. Although many of the flower beds contained plants which could not be used in this country, I will name the constituents of some seen. First was a bed with a double reddish colored dahlia, called *Glare of the Garden*, as a centre, next to it, yellow *Calceolaria*, next, variegated leaved geranium, ending with blue lobelia. Another had for centre yellow *Calceolaria*, next scarlet geranium, followed by golden leaved geranium and ending with blue lobelia. A third bed had single dahlias for centre, not in flower, blood leaved beet succeeding, followed by yellow flowered pansy, edged with blue lobelia.

The blue lobelia is a general favorite throughout England, as it is at Osborne, being used everywhere, where flower beds are.

One of the features of the place is a grove of cork oak trees, *Quercus suber*, containing perhaps 100 trees, which are already 40 feet high. Another grove contains the live oak of our Southern States, *Quercus virens*. In another part of the grounds can be seen a group of the strawberry tree, *Arbutus unedo*, a pretty sight when full of their strawberry-like fruit.

On these grounds, as everywhere in England, great use is made of the English holly and its variegated colored foliage. When the young leaves expand, their appearance is most beautiful. These would be useful as tub plants here, where too cold for them in winter. South of New York City they thrive in sheltered places if mulched in winter time to keep frost from roots.

Two Chinese plants, one a palm, *Chamærops Fortunei*, the other *Fatsia Japonica*, are quite at home at Osborne, as they are in many other places in England.

There are numerous memorial trees planted on the grounds. A splendid specimen of *Picea pin-sapo*, 50 feet high, and beautifully proportioned, was planted by Queen Victoria on her birthday, May 24, 1894, the label to it stated. Then there was the rare *Pinus Hartwegii*, 10 feet high, planted by the Shah of Persia, July 29, 1889.

An avenue running from the house to the shore was lined part of the way with huge tubs on each side, containing Portugal laurels, each one of which



had been planted by some notable personage.

As the residence of the good Queen of England the place is always of interest, aside from the many objects of horticultural interest it contains. This, and the company of some dear English friends, made my visit one of the most enjoyable of many others I had in England last summer.

*Joseph Meehan.*

#### Flowers at the Missouri Botanical Garden, St. Louis.

It would not have surprised me to find the Garden as bare as Mother Hubbard's cupboard instead of quite trim and nearly as flowery as ever, for there has been a fearful and wonderful combination of weather this year. It has been, in the main, favorable to vegetation (although too rainy) but St. Louis has suffered by reason of unprecedented local conditions.

Owing to the early opening of the season work was well advanced when the heavy rains of early May damaged spring bedding and necessitated much replanting. Then, on May 21, the severest hail storm ever experienced at the Garden wrecked glass to the extent of 7000 panes—some of it heavy green cathedral glass and made sad havoc in the summer bedding, then about finished.

The replanting was being pushed rapidly forward when, six days later, the memorable tornado that caused such wholesale and incalculable havoc in St. Louis arrived, to undo the entire work of the season, as well as damage to trees and shrubs that neither time nor money can make good.

The severest loss is among trees, 450 of large or fair size going down before the fury of the awful gale that accompanied and followed the tornado proper, which, revolving at terrific speed, dropped to the earth at a point nearer the center of the city where it began its ravenous meal by swallowing beautiful Lafayette Park whole.

In addition to this great calamity there have been heavy rain storms throughout the summer, and the last part of July and early part of August have been frightfully hot, so that, altogether, bedding plants have had rather a hard time even since being allowed to take root at all.

Despite all this the Garden looks attractive and fairly well furnished with flowers.

Eight or ten tree-shaped Crape Myrtles about four feet high planted out in an open group were lovely in their cloud of rosy creped blossoms, and so Japanese in effect that it seemed natural to find their odor the same as that of the Japanese *Lilium speciosum* although fainter as became their fragile type. The Crape Myrtle is tender here and is wintered indoors.

Hibiscus *Chinensis*, also tender, made an

excellent show planted out near the Palm House as well as in other locations.

Long beds of roses in three colors and varieties only, viz., Agrippina or Cramoisi superieur, bright red; Hermosa, pink; and Cels, an old fashioned creamy white rose. These are all ever blooming and are alike in flower and habit. They bloom continuously and abundantly and are relied on to furnish the bulk of summer roses.

A bed of Hybrid Remontant roses showed Souv. de la Malmaison in good flower, better than any other variety. Lantanas were especially good; *L. caviara*, deep scarlet, *L. nivea*, white, and a pink variety with some yellow florets were all in good flower. The last I am unable to give its specific name through my inability to locate the label that I do not doubt was there. These three Lantanas together with *L. Californica* with clear, soft yellow flowers would be fine massed together if care was taken to divide the pink from the scarlet by plenty of the white, *L. nivea*.

There was a bed of showy milk weed, *Asclepias curabserica*. It is taller than any I have heretofore seen in cultivation, not less than three feet, and has handsome flowers combining dark scarlet and flame color or orange scarlet. Another unusual looking bed was filled with two varieties of *Polygonum*. In the centre of a round bed were three or four plants not less than four feet high of the silvery leaved *P. lanigerum*, its flowers long, drooping, finger-like, white racemes, and these were surrounded by a circle of the green-leaved *P. orientale* with rosy fingers. Other beds noted were filled respectively with *Salvia splendens*, variegated hardy sage, the low spreading, blue flowered *Ceratostigma plumbaginoides*; *Ageratum*, var. Cope's pet, *Verbenas*, *Torenia Fournieri*, carpets of *Mesembryanthemum cordifolium*, Jerusalem cherries in fruit, *Nicrenbergia filiscaulis* with lavender petunia-like flowers; *Stevia freviarista variegata*, *Justicia velascina*, its odd flowers, shaped something like those of the Balms, and of a clear flesh pink; double *Portulacca*, *Gaillardia aristata*; carpets of *Lobelia erinus*, *Peristrophe angustifolia* and of *Thunbergia* in plain yellow and the same with a chocolate eye; and, the most effective and refreshing beds in the garden, luxuriant masses of rose and of white Vincas planted in oblong beds three or four feet wide, the two varieties massed half and half lengthwise in the beds. Apparently rainy weather suits Vincas, for I've never seen such vigorous growth nor large flowers before, nor such an abundance of bloom, among Vincas. A new and helpful feature of the Garden that should appeal to amateurs is a section labeled "All of the plants in this section are strictly hardy in St. Louis," and



each plant is distinctly labeled too. In this section I was pleased to note *Lonicera Heckrodti*, it is not only a lovely variety but each flower cluster is borne on a nice, long stem, making it more available for cutting than most of the fragrant Honey-suckles. It was brim full of blossoms, too, on August 3, another point in its favor.

Among herbaceous perennials, *Clematis Davidsoniana* and *Hibiscus Moschuetos* were in flower, the latter being wonderfully effective; which reminds me that I recently saw three varieties of *Hibiscus* in flower together with fine effect; the white, crimson-eyed, clear rose-colored, and a lovely pale pink distinct in tone from the preceding variety as well as much lighter in shade. They made a charming group. To return to the Garden, *Wigandia urens*, a large leaved plant, struck me as quite ornamental, having perfect leaves from the ground up.

Sweet Pepper Bush was in full flower and alive with winged insects.

Despite the numerous set-backs of the season, aquatics at the Garden look well, perhaps never better, and are more attractively disposed than ever before. But after all I think there is nothing in the grounds as fascinating as the vines. A limestone wall, probably eight feet high, divides the Garden proper from the Arboretum and serves as a back-ground for a splendid growth of creepers and climbers; such as *Wisteria* now showing a second crop of flowers, common Trumpet creeper now in full bloom, *Virginia creeper*, and *Vitisheterophylla*. The last seems a desirable vine in every way. It climbs as do all grapes, by tendrils, so must have some support, but its foliage is always fresh, green and clean, and it bears a continuous crop of berries from early summer until frost, which, when ripe are so lovely in color that it is sometimes called the Turquoise berried vine.

On a trellis against one of the green-houses a quantity of the Japanese vine, *Dolichos lablab*, bears an abundant crop of purple seed pods, even more showy than the lavender bean-like flowers, and, best of all, a most attractive drapery of *Ipomoea digitata* (*paniculata*) veils the end of the furnace-house and is carried quite over the top of the brick chimney, the upper half of the vines set thickly with large trumpets of a peculiar rosy violet shade similar to the color known to fashion as "eminence."

The entire flowering season has been rushed this year and a notable result of the unseasonable blooming of certain species is shown by *Hydrangea paniculata grandiflora* (in flower since about July 15) its beautiful balls of bloom seared or scalded to brown unsightliness by the terrific heat of late

July and early August, when for six successive days the mercury stood at from 96 to 99½ degrees in the shade, and the torrid heat was almost past endurance.

*Fanny Copley Seavey.*

#### Turkish Cemeteries.

A Turkish burial place does not leave a feeling of melancholy and sadness upon the mind of a visitor, as ours do. It is not situated outside the city far from the noise and activity of daily life. No walls separate the habitations of the dead from those of the living, or protect them from the careless tread of the passer-by. The burial ground is often in the city itself, penetrating into the midst of a group of houses, introducing itself among the shops, cutting across the streets and often forming a continuation of the same. It is a place of constant traffic, a thoroughfare, with well worn paths trodden down by the feet of men and beasts.

One goes to walk in such a place as a public garden. There the men lounge and smoke, the women sit and gossip in the shade of the tall cypresses; bands of children play around and on the tombstones, shouting and screaming street sellers wander about, selling cakes and sweetmeats, fowls are picking around or dusting themselves; here and there a solitary ass or mule is grazing the scanty tufts of grass, while bands of houseless dogs are lying in the sun or in the holes in the ground where the soil has sunk, which give them rare shelter from the weather. It is not rare to see a ropemaker plying his trade, with his cord stretched from tree to tree: and in spring, when carpets are taken up, they are carried as a matter of course to the cemetery, should one happen to be near, to be beaten. The cemetery of Pera, the "Grand Champ" and the "Petit Champ" have been compared to the Boulevard des Italiens or the Bois de Boulogne, and the comparison is not a bad one. They form a favorite promenade, and on a fine day there is an endless string of vehicles, riders and pedestrians passing up and down, to see and to be seen.

The cemetery of Scutari is the largest and most picturesque burial place in the East. It is a large wood of cypress trees, covering about a mile of rough, hilly ground, intersected by numerous avenues and covered with gravel stones. The trees are very unlike the poor little stunted specimens we are accustomed to see at home. Thanks to the heat of the climate they grow to an immense size, and their robust trunks, covered with the projecting rib-like veins running lengthwise, resemble the groups of columns in a Gothic Cathedral. Their branches are short, abrupt, but nevertheless the tree grows in an elegant pyramidal form.—*Springfield Republican.*



## Garden Plants,—Their Geography. X.

## GERANIALES.

## THE GERANIUM, CITRUS, AND CEDRELA ALLIANCE.

This is an extensive alliance of 35 tribes, 309 genera, and 3834 species, to which the unexplored regions of the tropics may be expected to add others. The tribes vary in aspect considerably and have a very wide distribution. Some of the genera, such as *Geranium* are almost ubiquitous, being scattered over all temperate regions and most of the tropical mountains elevated sufficiently to be temperate in climate. *Pelargoniums* are more numerous as to species perhaps, but are chiefly confined to South Africa and adjacent regions, and Australia. A great many useful plants are embraced within the group such as flax, the stimulant "coca" leaves of South America, the lignum-vitæ wood, the oranges and other fine fruits, the mahogany, toon, and other fine timbers, and several herbs and esculent tubers, these latter but little used in northern regions however. A variety of gums and wood oils are also produced by a number of species, while several astringents are of some repute in medicine.

As ornamental garden plants they are in great demand, and florists have multiplied the varieties of some species indefinitely.

*Linum*, "flax," has 100 species widely distributed over the world. Several have pretty blue, yellow, white or magenta flowers, mostly summer flowering and in perennial and annual kinds.



LINUM GRANDIFLORUM RUBRUM.

*Reinwardtia* is in 2 species natives of the mountains of India. One of them attains to some size in its own home, scrambling into the bushes to 10 or 12 feet high.

*Geranium*, "cranes bill," "herb Robert," &c., has 110 species, of wide distribution as previously remarked. They are perennial or annual herbs, not shrubs, and have regular spurless 10 stamened flowers, often purple or nearly blue. There are about a dozen *Geraniums* found wild in the United States.

*Pelargoniums* belong to a different tribe, and have 200 species with enormously more names. They are African for the most part, mostly South African. Many are shrubby, and have irregular spurred 5 stamened flowers, never blue or blueish. It does not seem to signify who confounds these two genera, or in what language, it is confusion; an element that botanists have shown themselves

abundantly able to perpetuate without aid from gardeners or anybody. There are annual, perennial, herbaceous, and shrubby *Pelargoniums* aplenty. They are enormously popular garden plants, and hybrids of the shrubby kinds in particular are countless.



PELARGONIUM TRICOLOR.

The genus is so extensive and various that Bentham and Hooker divide it into a number of sections. *P. grandiflorum* is reckon-



PELARGONIUM—SHOW TYPE.

ed the parent of the show and fancy strains, now coming into fashion again, but never quite out of it, and probably *P. tricolor* lent its aid also. *P. zonale* and *P. inquinans* are deemed the parents of the scarlet, pink and white bedders with their variegated forms. *P. peltatum* is supposed to be the parent of the Ivy-leaf forms. In gardens these have been recently hybridized and handsomely improved. In fact all doubles are acquisitions of



TROPÆOLUM MAJOR.





IMPATIENS HAWKERI.

the last 30 or 35 years. *P. graveolens*, *P. quercifolium*, and several others have agreeably scented foliage, and a variety of some one of these with variegated foliage known in gardens as *Lady Plymouth &c.*, is one of the handsomest edging plants we

have when uniform and well grown. But few manage a stock of it—the plants require keeping cool and dry overwinter, starting in time, and propagating in spring. Several of the tuberous rooted kinds endure underground at the South, while in California most all are hardy.

*Tropaeolum*, "Indian cress," is another genus whose muddling must I suppose be saddled on some "language." There are 40 species, natives of Mexico, Central and South America.

*Limnanthes* in 3 species are Californian annuals, with fragrant flowers.

*Oxalis* has 205 species scattered over the world, a few are pretty garden plants, but rarely seen in much use.

*Impatiens* has 225 species in Asia, Africa, Europe and South America. It is a very handsome genus, abundant on the tropical Asiatic mountains where they sometimes cover the surface of a bog, or the banks of a stream with inexpressible beauty. The beautiful little *I. Jerdonia* is epiphytic and should be grown like an orchid. *I. sultani* is just now quite a popular garden and window plant.

*Hydrocera natans* is a handsome monotypic aquatic plant of this affinity, with much variety of color; it ought to do well with us during summer. It is a native of India and Malaysia, commonly called the "water balsam."

*Ruta*, "rue," "herb o' grace o' Sundays," as Shakespeare puts it, sometimes becomes half wild from Central New Jersey southwards. It is not in much repute as a garden flower, it smells disagreea-

bly, but has pretty glaucous foliage, and is retained in some gardens as a simple medicine. There are 50 species from Mediterranean countries and from Central to Eastern Asia.

#### A Transformation Scene.

The accompanying illustration gives an idea of the change a short time will produce in a landscape under active measures of improvement. The view is taken in Forest Hill Cemetery, Kansas City, Mo., and the small cut in the bottom left hand corner is part of the same picture taken forty-five days before. The work was carried out the past spring. The lake is of artificial construction and is supplied from a spring some two hundred and fifty feet away, whence the water is piped for the purpose; it is also made to flow over a rocky ledge to create the



NYMPHÆA LAKE, AS SEEN FROM THE LODGE AT FOREST HILL CEMETERY, KANSAS CITY, MO.

effect of a natural rocky spring. While the purpose of the improvement is here a definite one, the picture very well illustrates what a little time it takes to change the entire aspect of a landscape under intelligent direction. The moral applied to our smaller cemeteries and neglected spots in our villages, should be a salutary one. A little concerted action, seasoned with individual enthusiasm would effect great changes in the neglected spots of our smaller places, and in many cases make even more marked transformations than the illustration given.

We are indebted to Mr. Sid J. Hare, the superintendent of the Cemetery, under whose management the work was carried out, for the photographs from which illustration is taken, and notes of the changed scene, which is a good practical example.



### The Milwaukee, Wis., Park System.

The real work of inaugurating a system of parks for the city of Milwaukee is of comparatively recent date, originating with a number of citizens in the winter of 1889. The result of their efforts was the passage of a law to establish a system of public parks within the city of Milwaukee, with the necessary provisions to make it operative. It allowed the five commissioners, to be appointed by the Mayor and to serve without compensation, one-hundred thousand dollars in bonds for the purchase of sites. The commissioners began active work at once but found the law inadequate in many respects, chiefly that it confined the choice of sites to the city limits which militated against any possible comprehensive system. However by the fall of 1890 five park sites had been secured. New park laws were enacted going into effect April 11, 1891, followed by other legislation covering the financial and tax questions.

Of the five parks then secured, two were located on the east side of the city and three on the south. On the east side is the beautiful Lake Park, in area 124 acres, occupying a promontory on the lake shore, some 100 feet above the water, situated in the heart of the residence district and commanding fine views of the bay.

About one mile from this is the attractive River Park, a tract of about 24 acres on the Milwaukee river, most picturesque in its location, resting as it does in the valley, with overhanging bluffs on either side.

On the south side is Mitchell Park, a tract of 30 acres, overlooking the Menominee Valley, of high rolling ground, in which are a small lake, fountain and many other park improvements. This park was the first completed as to design and considerable money has been spent on improvements. Another south side park is Bay View Park, an undulating oblong tract of 45 acres, having a fine growth of timber. Here a water garden has been prepared and the cultivation of aquatics will be undertaken under very favorable conditions.

The third south side park is a square tract of rolling land, in which the heavy work of improvement has been completed and which is much patronised for picnics.

Two parks on the west side of the city were secured in the fall of 1891. West Park comprises 124 acres of very high ground, a map of which is given herewith.

The Perrigo tract is 24 acres in extent, of level land half covered with a fine growth of timber. Upon this beyond underbushing and cleaning up, little improvement has yet been carried out.

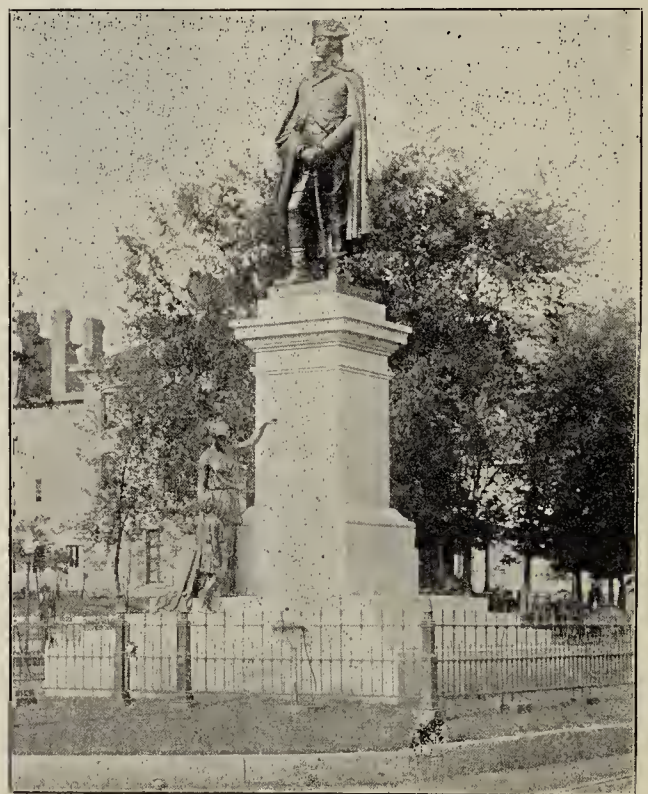
The original purchase price of these seven parks, 398

acres in all, amounting to the sum of \$1,039,644.20.

The improvements in the principal parks have been prosecuted with vigor and already display their landscape possibilities of the future. The commissioners have exercised a progressive and liberal treatment of the park question, always bearing in mind the object to be attained and the purpose for which the park system is devised—the pleasure and recreation of the people. Progress has been rapid and with commendable wisdom the commissioners have placed the designs of the park scheme and the special features required, into competent hands. Messrs F. L. Olmsted & Co., Brookline, Mass., were engaged for the landscape work, and their labors so far have been principally devoted to the two larger areas—Lake and West Parks.

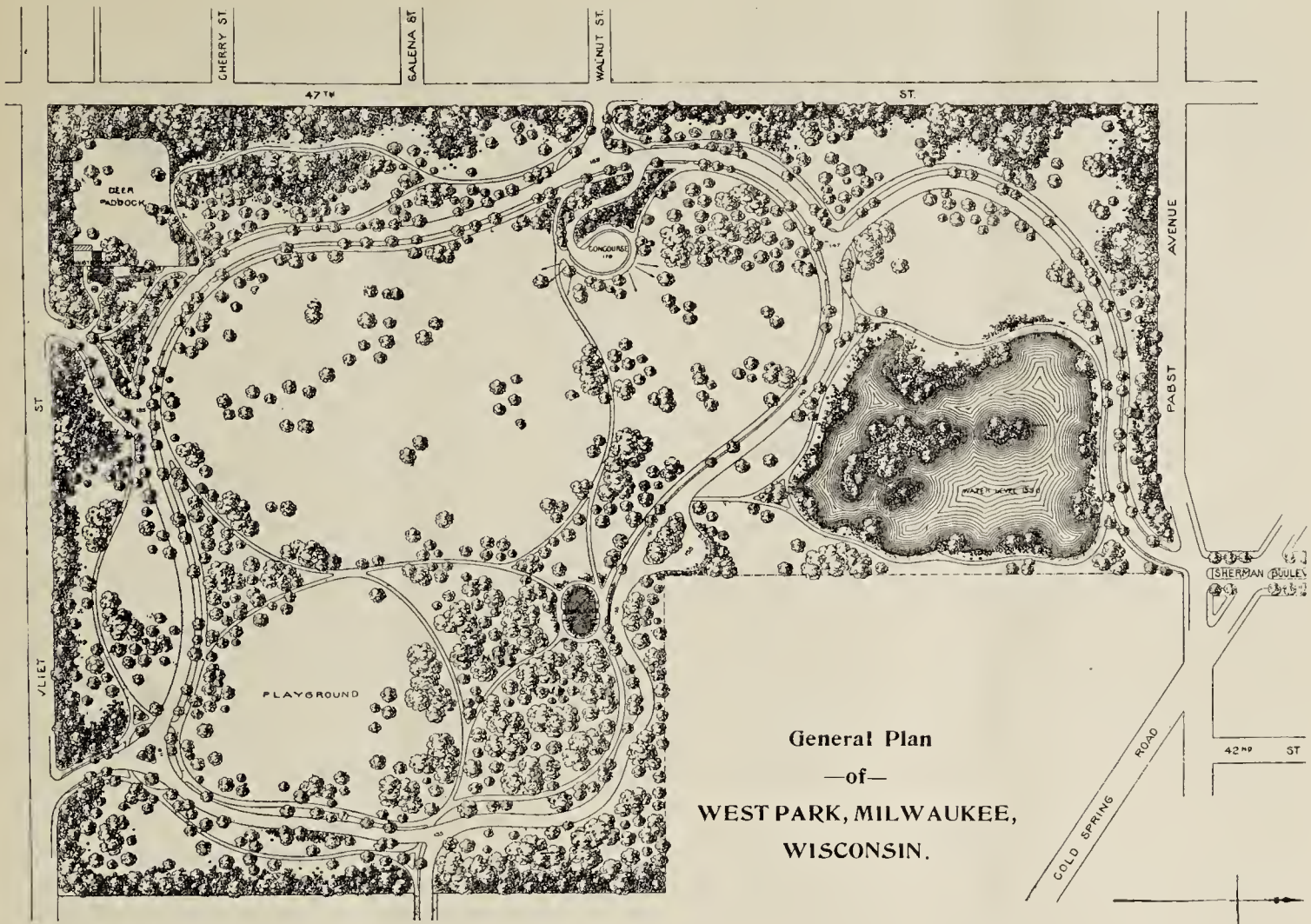
Improvements are rapidly being carried out on West Park under the design illustrated. The lake has an area of seven acres and contains three islands of diversified heights admirably adapted for the effective planting of low trees and shrubbery, brambles and ferns, and at the water line of such moisture loving plants as sedges, rushes, arrowheads, etc. Considerable road work has been done and paths constructed, as well as a fine start made on the tree planting scheme.

Of the system of road construction in this park, of which over a mile is complete, one method is as follows: "The base of the road consists of nine inches in thickness of quarry chips, bonded with



WASHINGTON MONUMENT, WASHINGTON PARK,  
MILWAUKEE, WIS.





General Plan  
—of—  
WEST PARK, MILWAUKEE,  
WISCONSIN.

Notes.

The oldest known rosebush in the world is found in Hildesheim, a little city of Hanover, where its stems have made a passage through a crevice in the wall and cover almost the whole church for the width and height of forty feet. According to tradition, the rosebush was planted by Charlemagne in 833 and the church having been burnt down in the eleventh century the root continued to grow in the subsoil. Mr. Raener has recently published a book upon this venerable plant in which he proves that it is at least three centuries of age. It is mentioned in a poem written in 1690 and also in the work of Jesuit who died in 1673.

\* \* \*

It may not be generally known that thickly populated as Europe is, there is yet considerable forest area. Russia has 503,000,000 acres of forests. In Sweden and Norway the forest area covers 62,000,000 acres; in Austria, 45,000,000; in Germany, 34,000,000 acres; in Turkey, 25,000,000 acres; in Italy 14,000,000 acres; in Switzerland, 1,700,000 acres; in France, 22,000,000 acres; in Spain 8,000,000 acres, and in Great Britain, 8,000,000 acres.

gravelly sand, and surfaced with three inches in thickness of limestone macadam, bonded with limestone screenings, each course being alternately watered and well rolled. Another method: First, a course of limestone macadam, seven inches in thickness at the crown and five inches in thickness at the gutter line, was laid and well rolled, then a course of hard limestone macadam of one and one-half inch cubes was laid on this bed and also well rolled, each course being bonded with limestone screenings and well watered before rolling; these drives are thirty-four feet in width, and bordered with cobble stone gutters, drainage being suitably provided for by catch basins and piping."

The whole project is devised to allow of boulevard connections between the several parks to the end that the city may have a park system, adequate for its growing needs, commensurate with its importance and capable of improvement and extension on lines of the highest development of park practice.

With the completion of the present design, the city will have a number of picturesque parks.

The monument illustrated, that of Washington, is situated in one of the small parks, established long before the commissioners were appointed to undertake the comprehensive system outlined above.



**Legal.**

## GROUNDS FOR APPOINTMENT OF RECEIVER.

A petition was filed, in the case of the Houston Cemetery Co. v. Drew, alleging facts to show, and charging, that the cemetery company and its officers had failed to maintain the cemetery in a proper state of preservation and adaptation for the uses and purposes to which it was dedicated; that they had, without authority, increased the stock of the company, by issuing watered stock; that they had executed a deed of trust, violation of law, upon a part of the grounds of the cemetery; that they had wrongfully misapplied a trust fund provided by the charter and by-laws, for improving and keeping the cemetery, by loaning it to the company, and executing the above-mentioned trust deed; that they unlawfully imposed a tax upon the transfer of burial lots by the lot owners, and had closed, altered, and changed the drives, roads, and other open places in the cemetery. The Court of Civil Appeals of Texas holds that this would authorize the appointment of a receiver, without it being made to appear conclusively that the plaintiff was entitled to recover. It says the cemetery company, whether as a kind of public corporation, or one strictly private owed duties to its lot owners and shareholders, which it might be compelled by the courts to perform. The fact that the father and other relatives of the judge were buried in the cemetery, he not being a lot owner, did not disqualify him from hearing the petition on the ground of interest in the suit. And the allegations of the petition above recited were sufficient to excuse complaining shareholder from seeking redress through the corporation. There can scarcely be any doubt, says the court that a lot owner in a cemetery corporation has such an interest therein that he may be protected in a proceeding of this kind. He is not the owner of an easement or mere right to use, and his right to have the drives, walks and approaches kept in repair does not depend upon the law of easements, as it is technically called.

## BOARD OF HEALTH TO SAY ABOUT CEMETERIES.

A law was passed in New Jersey, which was approved March 5, 1896, that provides that no new cemetery shall hereafter be established, nor shall any cemetery now existing be enlarged or any lands not used for cemetery purposes be used for such purposes in the cities of the first class in that state, without the consent of the common council and board of health of such city, to be expressed by resolution and the approval thereof by the mayor of such city.

**POLITICS IN PUBLIC PARKS.**—During the last ten years, there has been marked attention to pro-

viding public parks or small open squares for the people in the greater majority of the larger cities of the Union; but much complaint is made that politics dominate to such an extent that very little real good is obtained from the tax-payers' money. It is frequently spent extravagantly, while the amount of pleasure derived from the expenditure is proportionately small. The writer of this paragraph has had some fourteen years experience as a legislator in one of the largest cities of the Union, and his experiences are,—for all the objections the American people generally have to Boards and Commissions—that their parks and pleasure grounds are more likely to be well managed under Boards and Commissions, than under the direct supervision of City Councils themselves. Politics will enter into Boards and Commissions just as much as they will into the management directly by the city; but the continual changes which follow this latter direct management are far more disastrous than even the influence of politics, in affairs of this kind. To have a good successful park or garden, there must be a regular plan to be carried out; but with incessant, and almost yearly, changes in management, what is done one year is upset the next; and there is far more waste through this, by the personal influence referred to, than in general politics. There is, however, always this in connection with parks and open spaces, that although they cannot be managed in the best possible interest of public wants, the open spaces in themselves are of value. It has fallen to the good pleasure of the writer to add nearly 1000 acres in numerous small parks for the city in which he resides; but although sometimes grieved that they are not, and probably will never, be managed as they might be for the best interest of the community, they will afford recreation to thousands. They are not what they might be, still they are of great value as they are.—*Mechans' Monthly for August.*

Near Ardenlee in Scotland, there is an attractive and effective advertisement, made of flower-beds. The beds are each a gigantic letter, forty feet in length, the whole forming the words "*Glasgow News.*" The total length of the line is 123 feet, and the area covered by the letters, 14,845 feet. It is laid out on the side of a hill, and, being of bright-colored flowers, can be read for a distance of four and a half miles.

The oldest tree in England is the yew tree at Braburn in Kent, which is said to be 3,000 years old, while at Fortignal, Perthshire, is one nearly as old. At Ankerwyke House, near Staines, is a yew tree which was famous at the date of the signing of the Magna Charta



## PARK NOTES.

An attractive fountain has been presented by a Jewish order to the Home for the Aged at Yonkers, N. Y. It is a tasteful and serviceable gift, and in connection with this gift it may be mentioned that there has, in recent years, been a remarkable growth of the love of art among the Jews of New York.

\* \* \*

A pleasing feature of the centennial celebration of Cleveland, O., in July, was the presentation to the people by John D. Rockefeller, of a tract of land for a public park. The tract comprises 276 acres and is valued at \$600,000. It was a generous and appropriate gift and will be a lasting memorial of the donor.

\* \* \*

The largest of Brooklyn's parks, is Forest Park, which contains 570 acres as against 516 of Prospect Park. It is two and a half miles long and varies in width from 1000 to 2500 feet. A large ridge affords magnificent views of ocean, sound, harbor and adjacent country. It is one of the newer parks and the preliminary work of preparation for public use is nearing completion.

\* \* \*

The town of Branford, Conn., has been the recipient of a valuable memorial in the shape of a library building costing over \$300,000. It was erected by T. B. Blackstone, President of the Chicago & Alton R. R., Chicago, in memory of his father. The Blackstone family occupies a prominent position in the town's history and the Blackstone Memorial Library is an appropriate and magnificent gift.

\* \* \*

Omaha, Neb., has been studying the question of profits of their park greenhouses and nursery. For 1895 the profits of the greenhouses were \$4,226.89 and of the nursery \$1,102.85. This appears to have been estimated from the value of the stock produced for parks and boulevard purposes less the cost of production. These figures substantiate the necessity of such adjuncts to the park establishments.

\* \* \*

Jersey City, N. J., recently received a gift of two and a half acres of land in its midst for a city park. No more fitting and enduring memorial could be provided by wealthy land owners in most of our cities than small parks for breathing places. It is the crying need, which must be met by the municipalities, unless donated as above, where such gifts have a double significance—a beneficence and a memorial.

\* \* \*

One of the highest hills in the west end of Pittsburgh, Pa., is being converted into a park and will soon be completed. As a lookout this park will afford unrivalled views of picturesque country. A sixty foot driveway, 2,500 feet in length will wind around the face of the hill, and will command magnificent views out across the deep hollows and over the other hills of that locality. A lookout house is to be built at the summit.

\* \* \*

The report of the Board of Park Commissioners for the city of Milwaukee, Wis., for the year ending March 7, 1896, shows a total expenditure for regular employes and labor of \$38,061.17 and for improvements and materials, \$65,664.63. The receipts from rentals, sales and boats amounted to \$904.11. The total receipts from taxes and all sources were \$163,830.49, and the disbursements \$105,887.84, leaving a balance available for current year of \$57,942.65.

\* \* \*

Manchester, N. H., is aroused in the cause of Parks, and its area of 118 acres, divided into 6 small parks containing some 20

acres and two larger ones, are receiving attention with a view to making them all the more attractive and useful for the purpose of pleasure and recreation. The city is so conditioned as to make a system of parks, possessing characteristic beauties, easily attainable. The amount appropriated for the care and improvement of the parks was \$9,000. Manchester has 44,000 inhabitants.

\* \* \*

Patrick Calhoun, a southern capitalist, of late a resident of Cleveland, O., has presented that city with land on Euclid Ave. valued at \$175,000, for park purposes. The property runs parallel and in part adjoins the donation of Mr Rockefeller. This will assure the completion of a plan to straiten Euclid Av. and construct a small circular park. The only stipulation Mr. Calhoun made is that he shall retain a strip 20 feet wide to enable him to operate a street car line or other means of conveyance to the residence property beyond. Money will be raised at once by bonds for improvement purposes.

\* \* \*

By the will of Jane Bayne Teece of Allegheny, Pa., it is provided that at the death of her sister, to whom she leaves a life interest in the estate, a lot of ground in conjunction with the residence and grounds of the said sister, Mrs M. A. Balph. shall be given to the borough of Bellevue for library and park purposes for the use of the residents of that borough. A sum of \$10,000 in addition to a similar bequest of Mrs. Balph is provided for its maintenance. Managers are appointed for the gift and any further sum remaining after other bequests are paid shall be added to the fund. Under no circumstances shall the large elm trees on the said grounds be removed until after their natural death.

\* \* \*

Paris will be made a wonderfully attractive place for the international exposition of 1900. According to reports the proposed improvements will be of a permanent character as far as possible. There will be public parks, gardens, and squares created in all parts of the city, for example at St. Philippe du Roule and in the St. Marguerite quarter. Rows of trees will be planted at the Place de Rennes, and the banks of the Canal St. Martin will be covered with turf. The rows of trees in the Champs Elysees will be doubled, and still more trees will be planted in the Avenue de Bois de Boulogne. The roads leading into the Bois from the Auteuil side will be arranged in terraces, covered with flowers, and overlooking the valley of the Seine. The park and the gardens on the Butte Montmartre will be finished by that time. At night the city will be brilliantly illuminated by an extensive system of electric lights as far as the outer boulevards and including the Bois de Boulogne and Vincennes.

\* \* \*

Speaking of the trees and other material features in our parks, Mr. Frederick Law Olmstead in one of his reports says: It would be more interesting and refreshing, by way of contrast with city streets and gardens, if the trees planted in local parks were less uniform in kind and appearance, less like trees; if the slopes were more gentle sloping shores, more mystery and intricacy of water-loving plants, marginal shrubbery and groups of trees, if what purport to be natural lawns were kept free from stiff beds of flowers, dropped here and there without regard to general landscape effect or good design of any sort; and if the surrounding houses were, at least, particularly screened by border plantations of trees and shrubbery. Owing to their situation, restricted size, and to the necessity for accommodating people in such a way as to reduce the wear upon turf and plantations to a minimum, the walks and other artificial construction must necessarily be disproportionately large, and often unduly conspicuous, but care should be taken, both in the designing and in the grading and planting to render all artificial constructions as subordinate as possible to the general effect of verdure.



---

## CEMETERY NOTES.

---

The Simsbury Cemetery Association, Simsbury, Conn., has received an unconditional gift of \$6,000 from Mr. Amos R. Eno, New York.

\* \* \*

The Mankato Cemetery Association, Mankato, Minn., has adopted a recommendation to transfer twenty per cent of the sales of single graves to the perpetual repair fund.

\* \* \*

A Michigan editor received some verses not long ago with the following note of explanation: "These lines were written fifty years ago by one who has for a long time slept in his grave merely for a pastime.

\* \* \*

The Woman's Cemetery Improvement Association, Traverse City, Mich., leaves no stone unturned to raise funds for the work. The latest scheme is the "Saturday Market," where provisions prepared for Saturday's and Sunday's tables are offered for sale.

\* \* \*

Burial seems to be cheap in Japan. The funeral of a workman costs from 83 cents to \$1.25. The coffin is supplied for 20 cents; for cremation, 75 cents is paid, and the mourners cheer themselves with refreshments which cost about 11 cents, though sometimes as high as 25 cents.

\* \* \*

Mr. Geo. Creesy, Supt. Harmony Grove Cemetery, Salem, Mass., reports an excellent case of embalming as having come to his notice. A short time ago he had to remove a body which had been embalmed in St. Paul, Minn., thirty-five years ago, and on looking at the features they presented the appearance of having been dead but a few days.

\* \* \*

The effect of the recent torrid spell in New York found its most appalling expression in the funeral record. On August 16, a special to the *Chicago Tribune* said: notwithstanding work night and day, graves could not be prepared fast enough to meet the sad demand. There were 460 funerals in New York and 200 in Brooklyn on the above date. 1810 persons died in New York the week ending the 16th. The dispatch stated: Because of the difficulty of securing caskets, hearses and carriages, or even undertakers' services beyond the simplest and most necessary, nearly all the funerals for that period were delayed until to-day. There were thirty-six hearses borrowed from adjoining towns in New Jersey and twelve from Philadelphia for to-day. Several New York undertakers whose rush was over loaned hearses to Brooklyn friends. Other hearses were added to Brooklyn's supply from Long Island towns, as there was nearly one-fourth of the week's 879 dead in that city still unburied.

\* \* \*

The eccentricities of wealth is perhaps oftener displayed in connection with the cemetery than otherwise. A story comes from Paris, that the authorities of Pere la Chaise have had to contend with a case which has caused much trouble. A wealthy old French woman lost both her husband and son within a short time of each other and determining that their fortunes should follow them into the grave, she had all of her available property converted into gold and bank notes, which she placed in the

vault with the remains of her loved ones, and as fast as any other money came in, that, too, she added to the buried treasure. The story got out. Thieves flocked to the place, endeavored to break open the tomb, and steal the fortune, amounting to millions of francs. Finally the authorities were obliged to place a special guard over the tomb and forbid the poor woman putting any more valuables in such tempting reach of thieves. Her last addition to the place was a 20,000-franc vase, which she carefully lowered into the vault before it was finally and forever sealed up by the authorities, whose lives were made a burden by her novel method of disposing of her wealth.

\* \* \*

Oakwood Cemetery, Red Wing, Wis., is a very practical object lesson in what may be accomplished in the work of improving a cemetery, rescuing it from the old style graveyard and transforming it to the modern idea. It is located on a bluff some 400 feet above the Mississippi River, and till a few years past was approached by an unimproved ravine, up which the first settlers carried their dead for many years. Then again for many years the city authorities permitted the lot owners to do their own work, in their own way, and with the usual result, an unsightliness and confusion of practice deplorable to a degree. All this has now been changed and mainly by the devotion and unrecompensed labors of a member of the board of cemetery commissioners, which was created by ordinance a few years ago. To Daniel Densmore, the first president of the board, is principally due the altered conditions now ruling at Oakwood Cemetery. As fast as practicable the lawn plan is being introduced, and already a wonderful improvement has been effected. The cemetery is beautifully situated, the land well adapted for the purpose, and there is every possibility of its becoming as beautiful a "City of the Dead" as any in the country, thanks to persistent effort coupled with wise forethought and a knowledge of the consideration due to a cemetery in this enlightened age.

\* \* \*

Old St. John's Cemetery, on Hudson street, between Clarkson and Leroy streets, New York, is about to be transformed into a public park, the property having been condemned for that purpose by the city. The price paid was \$520,000. The ground has a frontage of 208 feet on Hudson street and one-half as long again on each of the side streets. It was owned by the Trinity corporation. This cemetery was opened about the beginning of the century, and although the burial ground of the entire parish, the cemetery was called after the nearest church of the parish, St. John's Chapel. Interments except in vaults were prohibited about 1850. It has been neglected for many years, and with its untrimmed trees, long grass, and tangled brush looked like wild woodland. A house on the Clarkson street side of the cemetery close to the part occupied by the graves, was formerly a chapel in which services for the dead were held. It does not appear that the fashionable people used it, as there are very few conspicuous memorials. Most of the graves are marked by the cheap slab of marble. The most pretentious is the fireman's monument, erected 1834 to firemen killed in discharge of their duty. The descendants of the persons buried in the cemetery do not appear to be concerned by its proposed transformation to a park. Few seem to have proposed to transfer any of the bodies. Some firemen have interceded for the firemen's monument and Trinity corporation will take steps to preserve it by transferring it to some other site; the other tomb stones will probably be sunk into the ground near the graves over which they have stood sentinel so long. In years to come, when the records of old St. John's Cemetery have been buried in the archives, and the whirl of the present civilization has obliterated its memory, excavations on the site will disclose another buried grave-yard, and speculation will be busy as to "all about it."



A large number of floral crowns and garlands collected from ancient Egyptian tombs and generally in a state of good preservation has been collected. Melons thousands of years old have been immersed in water, when traces of their original green color have been seen. Among the specimens are the blue and the white lotus, the red poppy, the oriental larkspur, hollyhock, different species of chrysanthemums, pome granates, leaves of willow and celery and several kinds of grasses of the Greco-Roman epoch.

\* \* \*

While excavations were being made on the Hessian plot in the Centre cemetery, at Bennington, Vt., recently preparatory to placing the granite pedestal that is to mark the spot, they came across several parts of skeletons, supposed to be the remains of Hessians buried there in 1777. From the length of the bones of one of the skeletons it is judged that the body to which they belonged must have been seven feet or more in height

\* \* \*

There is only room for a few more graves in the old Moravian burying ground in Bethlehem, Pa. This historic burial ground was laid out in 1742 and has been in use ever since. The first interment was made on July 27, 1742, when John Mueller, Jr., was buried. Going through the old "God's acre" one passes nearly 3000 graves, among which are those of fifty-six converted Indians, seventeen negro converts and one convert from Ceylon.

\* \* \*

The enforcing of the new burial act of Michigan is reported to be causing the cemetery officials trouble. It has hitherto been the custom for the doctor's certificate of death to be given to the cemetery officials with cause of death and other particulars marked thereon. Under the new rule, however, the certificate is given to the city clerk who issues a permit, which however, has none of these necessary particulars. The government requires such information, but, as it now stands, the cemetery authorities have no means of declaring the cause of death.

---

## ≡Correspondence.≡

---

NEWARK, N. J.

*Editor Park and Cemetery,*

DEAR SIR: It was with much pleasure that we read Bro. Wm. Stone's contribution to the June issue. Following his example and to encourage others, I offer a few lines. Brother Brazill writes hopefully of the St. Louis convention; he has been hard at work making preparations to insure success, and arrangements have been consummated for several addresses to be made to the convention. Our Secretary is also at work and informs me that matters appear very favorable for an interesting occasion. As our supply of badges were exhausted, at request of Treasurer seventy-five new ones were ordered which can be obtained from him. We consider them to be an improvement on the old badges, and advise members not having one to write to the Secretary. It must have occasioned both surprise and regret to our members to learn of the abrupt termination of John G. Barker's relations with Forest Hills Cemetery, Boston.

Yours truly, *Chas. Nichols.*

\* \* \*

SALEM, MASS., July 9, 1896.

*Editor Park and Cemetery,*

DEAR SIR: In looking over the June number I found something very interesting, and when one is interested the next thing is to see how he can interest some one else. Bro. Stone

loves to write, and especially when he can just stir up some one. He speaks about Bro. Creesy being five miles away and is trying to work him up. The fact is Bro. Stone has been to sleep and has just woke up, and that is where the shoe pinches. He says his lily pond is undergoing its spring renovating,—ours we attended to in the spring and now it is looking grand, what it will be when his begins to be attractive is beyond my comprehension. Now ask Mr. Stone about his cacti-bed and also his principal centre-piece and he will tell you if you want to see the handsomest and most unique bed you ever saw go to Harmony Grove Cemetery, Salem, Mass. I propose to send you a little later in the season a photo of our "Rock of Ages," and which will be an ornament to the pages of PARK AND CEMETERY. Mr. Editor, the time is not far distant, when we, like a great many other people, will be packing our grips and seeing what tickets will cost for the trip to St. Louis, and if it would not be too much trouble, I should like you to enquire through your columns how Bro. Eurich is getting along with these railroad fares. If we superintendents should all do the same as our good old Father Nichols is doing, write to all and see what we can do to start them, I think it would be a good thing. We want to encourage and impress our Cemetery Trustees with the facts that we are something more than a lot of politicians who get together and make platforms that cannot be sustained. We are the party who have the only and sure foundation before us. Now let us all, as far as we can, try and give our Brother Superintendent Brazill to understand that we are coming to St. Louis to see him and learn all that we can for the benefit of our cemetery and its future prosperity. Yours truly, *Geo. W. Creesy, Supt.*

\* \* \*

Mr. W. Clauson, superintendent Hillside Cemetery, South Plainfield, N. J., commenting on the suggestions contained in the extract from the Rules and Regulations of Pine Grove Cemetery, Lynn, Mass., concerning Sunday funerals, says most superintendents would be glad of the opportunity to close the cemetery for burials one day in the week, for rest for themselves and men, and he is glad that one cemetery corporation takes that stand. He wishes all would say, "No burials on Sunday, bodies brought that day must be left in the Tomb." In his locality there has been lots of rain, plenty of grass and much work in general in the cemetery. The lawn mowers have not been idle this summer. Flowers and shrubs have been in their glory, and every cemetery should have been seen at its best.

\* \* \*

St. John, N. B., has, practically speaking, no public park but the laudable desire to provide such a necessary adjunct of city life is the principal object of the Saint John Horticultural Association. This association has issued an exceedingly attractive pamphlet containing prize lists for its two floral exhibitions this year, considerable information on the culture of plants, a report of its success in the establishment of a public park, and an appeal to the citizens of St. John for the same object. Last year the association expended over \$5,000 in the purchase of lands and improvements on the same, and have already acquired a considerable acreage. The association numbers in its ranks many of the leading citizens of St. John, and evidences a public spirit highly commendable and worthy of imitation elsewhere. The love of the cultivation of flowers and plants is a sentiment, to stimulate which in a community is the duty of every well-wisher of the human race. Nothing so promotes high thinking and high living as intimate association with these marvellous developments of nature's handiwork, and all classes find a common ground in the care of flowers. The Rural Cemetery of St. John has often been referred to in these columns as being improved on progressive lines, profiting by the efforts over the border, and this idea of park promotion does credit to the community.



### Association of American Cemetery Superintendents.

O. C. SIMONDS, "Graceland,"  
Chicago, President  
G. W. CREESY, "Harmony Grove,"  
Salem, Mass., Vice-President.  
F. EURICH, Woodlawn, Toledo, O.,  
Secretary and Treasurer.

The Tenth Annual Convention will be held at St. Louis, September, 15, 16 and 17.

### Publisher's Department.

NOTICE TO SUBSCRIBERS. If this notice is marked with a blue pencil it indicates that your subscription to PARK AND CEMETERY has expired and a renewal of same is solicited.

Park Commissioners and Cemetery trustees are requested to send us copies of their reports.

Photographs and descriptive sketches of interesting features in parks and cemeteries are solicited from our readers.

PARK AND CEMETERY wants the names of every park and cemetery official or employee who would be likely to be interested in this paper. To the many subscribers who have sent in such list of names, we return our thanks. There are many more that we should hear from.

Subscribers are again reminded that we want brief notes on any feature of park or cemetery work that will be of general interest. PARK AND CEMETERY is the only publication of its class and earnestly solicits the co-operation of subscribers in making it a help to all identified with such work.

Our correspondent Mr. James MacPherson has been appointed consulting landscape gardener to the Board of State Hospitals of New Jersey, and is submitting a scheme for an Arboretum on substantially the same plan as published last September, page 110.

Mr Bellett Lawson has assumed charge of Woodlawn Cemetery, Winona, Minn., and is making many changes to improve and bring the cemetery up to the standard of modern ideas. It is beautifully situated, commanding extensive views. In many ways it offers excellent opportunities for the creation of fine effects and the satisfactory results which accrue to intelligent work.

The Boston *Herald* of July 11, contained a lengthy article giving the details of the recent changes in management of Forest Hills Cemetery, which resulted in the resignation of the president Mr. Joseph H.

Chadwick, the abrupt dismissal of Mr. Jno. G. Barker, superintendent, and the treasurer Mr. Edward B. Reynolds. The violent turn in affairs is deplored by the conservative lot owners, and general regret is expressed at the loss of the president, whose vested interest in the cemetery is among the largest, and of Mr. Barker, whose many friends are anxious for his reinstatement. The *Herald* speaks in a highly commendatory manner of Mr. Barker's work in the cemetery, with which he had been connected as superintendent for ten years, the period of the cemetery's greatest development and prosperity. It is predicted that an active campaign will be carried out for the next annual meeting to vindicate or condemn the present management.

#### RECEIVED.

First, Second, Third and Fourth Annual Reports of the Park Commissioners of the City of Milwaukee, Wis., for the years 1892, 1893, 1894, 1895.

Report of the Board of Park Commissioners of Omaha, Neb., 1895.

Report of the South Park Commissioners of Cook County, Illinois. December 1, 1894 to December 1, 1895.

Maple Grove Cemetery, Queens Co., N. Y., Rules, Regulations, etc. 1896. The pamphlet is illustrated and also contains a list of lot owners.

Annual Report of the Street and Park Commissioners of the City of Manchester, N. H., for 1895.

Report of the Board of Metropolitan Park Commissioners, January 1896, Boston. A book of 107 pages handsomely illustrated with photo gravures, and many maps.

Twenty-seventh Annual Report of the West Chicago Park Commissioners for the year ending December 31, 1895. Illustrated with half-tones and maps.

Prize List of St. John, N. B., Horticultural Association's Exhibitions for 1896.

Annual Message of the Mayor, Annual Reports of the City Clerk; Comptroller; Board of Public Works; City Engineer; Chief of Police; Chief of Fire Department and Supt. Fire Alarm Telegraph, of the City of La Crosse, Wis., for the year ending December 31, 1895.

First Annual Report of the Board of Park Commissioners of the City of Indianapolis, Ind., 1896. Accompanied by copy of City ordinance containing Rules and Regulations for the government of the Public Parks of Indianapolis, Ind. Approved June 30, 1896.

Fifth Annual Report of the Board of

Park Commissioners of the City of St. Paul. For the year ending March 1, A. D. 1896. Illustrated with many half-tones and maps.

Third Annual Report of Board of Park Commissioners of the City of Des Moines, Iowa, 1896. Illustrated with many half-tones.

Fifth Annual Report of the Board of Park Commissioners of the City of Omaha, Neb., including recapitulation of Park affairs since the organization of the Park Board in 1889. Illustrated with a number of half-tones.

Annual Report of the Parks-Commission of the City of Worcester, for the year ending November 30, 1895. Illustrated.

Rules, Regulations, etc., "Mount Olivet" Cemetery Association, San Francisco, August, 1896, accompanying a handsomely gotten out pamphlet, illustrating and describing their new cemetery.

Massachusetts Horticultural Society. Report of the Committee on Gardens, for the year 1895. By John G. Barker, Chairman.

Report of the Commissioners of Lincoln Park, Chicago, April 1, 1895, to March 31, 1896.

#### Expressions From Our Subscribers.

I am very much attached to PARK AND CEMETERY and get much valuable information from it.—*W. D. Diuguil*, Lynchburg, Va.

PARK AND CEMETERY is a great aid to all persons interested in up-to-date cemetery management.—*Aaron Sonneborn*, President Pueblo Cemetery Association, Pueblo, Colo.

I am much pleased with PARK AND CEMETERY, as I believe all cemetery officials must be, for it is certainly very instructive and useful to us in so many ways.—*W. C. Rapp*, Supt, Fort Plain, N. Y.

PARK AND CEMETERY improves with each issue, and contains much useful information on the subjects discussed.—*J. G. A. Boyd, Sec.*, Cave Hill Cemetery, Louisville, Ky.

PARK AND CEMETERY is doing much towards educating us in cemetery lore.—*Robt Waring*, Tyrone, Pa.

It is with pleasure I peruse PARK AND CEMETERY. As it grows in age, it is improving all the time in matters of great value to cemetery superintendents and others.—*Henry Thompson*, Mt. Pleasant Cemetery, Toronto, Ont.

I find PARK AND CEMETERY a great help to me, and always full of news.—*Sid J. Hare Supt.*, Forest Hill Cemetery, Kansas City, Mo.



# PARK AND CEMETERY.

FORMERLY THE MODERN CEMETERY.

A Monthly Journal Devoted to Parks and Cemeteries.

R. J. HAIGHT, Publisher,  
334 Dearborn Street, CHICAGO.

Subscription \$1.00 a Year in Advance. Foreign Subscription \$1.50.

VOL. VI. CHICAGO, SEPTEMBER, 1896. NO 7

## CONTENTS.

EDITORIAL.....	323
*THE ST. LOUIS MEETING OF CEMETERY SUPERINTENDENTS.....	324
PRESIDENT'S ADDRESS.....	324
WHAT A CEMETERY SHOULD BE.....	327
CONVENTION NOTES.....	329
TREES.....	329
*GARDEN PLANTS, THEIR GEOGRAPHY, XI.....	330
*BELLE ISLE PARK, DETROIT, MICH.....	332
ACCEPTABLE GROUPING OF MIXED SHRUBS.....	334
*THE GILBERT MEMORIAL BUST, GRAND RAPIDS, MICH.....	335
*PARK PLACE, HENLEY-ON-THAMES, ENGLAND.....	336
PARK NOTES.....	337
CEMETERY NOTES.....	338
LEGAL.....	339
PUBLISHERS DEPARTMENT.....	340

\*Illustrated.

KEEP off the grass" signs in Central Park, New York, are raising questions in the public mind as to what the parks are for. The main reason for such restrictions as given in an interview in a New York daily with the superintendent is: "That much of the productive soil of Central Park is artificial and will not stand the wear and tear that the trampling of feet and constant use will put upon it." The results of the liberal policy pursued in Chicago and many of the so called western cities, minimizes the force of this argument and strengthens the public view. The less the restrictions placed upon the use of the public park, the more logically does the park fulfill its mission. The public park is not the place for the exercise of official ideal landscape work to the exclusion of the people, but it is the place to make ideal landscape work of practical value to those who provide for and conserve it—the public. That this is possible, notwithstanding adverse climatic conditions is amply

proven in Chicago. It may involve more expense, but the extra expense is in an inverse ratio to the benefits conferred. The care of the Chicago parks is not confined to daylight, but during the hot and dry season the care and watering is continued throughout the night. By this treatment the wear and tear of the season is met, and the people enjoy to the utmost all their parks afford them. That it is possible to keep the grass in fair condition under the most unfavorable circumstances, a visit to some of the western parks will show, and moreover, an investigation of the benefits conferred and the popularity secured will convince that a liberal policy with regard to the freedom of the grass is the proper policy.

IN speaking of the parks of Brooklyn, the *Brooklyn Eagle* strikes a chord generally avoided, the spirit of which if the prophetic utterances of poet, preacher and philosopher amount to anything, must soon become the text for and test of good municipal government, and the main spring of general government—the enlightened interest in the physical well being of the poorer classes. In closing an article, the above journal, after commending the reservation of large spaces for public use as good government and wisdom, says: "There is a growing sentiment in favor of a public right to pleasure. It is at the bottom of the communistic and populist agitation. It inspires much of the prevailing enmity and jealousy of the rich. For the poor life is little more than work and hardship and too often its pleasures are in the seeking of forgetfulness from hard conditions. But there is a tendency to ameliorate those conditions. It is with that view that tenements have been torn down and others improved; that free baths have been provided; that libraries and reading rooms and lectures have been established; that band concerts have been given in parks and squares; that statuary and fountains have been erected and trees and flowers set out; that art has been put in public buildings. Everything of the kind tends to put the poor man on an equality with the rich and relieve the bitterness of his life. There is more than passing pleasure in these common holdings; there is life, health and understanding."



### The St. Louis Meeting of Cemetery Superintendents.

It was under the most auspicious conditions that the Association of American Cemetery Superintendents held its tenth annual convention at the Planter's Hotel, St. Louis, Mo., September 15, 16 and 17. The weather was pleasant, the attendance unusually good, the papers read were extraordinarily interesting, and the entertainment provided for the visitors was of a most delightful character. Mayor Walbridge extended a cordial welcome to the "mayors of the sacred cities" to what he believed to be one of the liveliest cities in the country. He likened the duties of the mayors respectively, and found much in common in the work they had to perform. President Simonds responded briefly. After the admission of eight new members Mr. Simonds read his annual address as follows:

#### PRESIDENT'S ADDRESS.

An article by Frank Foxcroft which appeared a few months since in the *New England Magazine*, calls attention to the fact that Mt. Auburn is the oldest rural cemetery in the United States, it having been consecrated sixty-five years ago. Its creation was due chiefly to the thoughtfulness and energy of Dr. Jacob Bigelow, who called together a few representative men of the city and laid before them his plan for a rural cemetery. A short time before he did so, a Mr. Brimmer, in order to save from destruction certain trees and other natural attractions, had purchased a piece of woods known to the Harvard students as Sweet Auburn and this tract he readily consented to sell at the original cost to himself. Dr. Bigelow went before the officers of the Massachusetts Horticultural Society with his plan and received encouragement and substantial assistance. Previous to this time the dead of Boston were buried in churchyards and burying grounds in the crowded parts of the city, and cellars of churches were filled with sepulchres. The motives for the establishment of the new burial place were the desire to secure more healthy surroundings for the living and more beautiful surroundings for the dead. The establishment of Mt. Auburn was the first great step taken in the United States to bring about a sanitary and beautiful method of disposing of the dead, but although the founders loved nature perhaps as much as we do at the present time, they failed to preserve the beauty which attracted them and introduced many ugly and useless features under the name of "improvements."

After Mt. Auburn, as you all know, came Laurel Hill of Philadelphia, Greenwood of Brooklyn, Spring Grove of Cincinnati and many other beautiful cemeteries. The second great step in advance was taken at Cincinnati a little over forty years ago and was in the direction of greater simplicity and more attractive landscapes. Hedges, fences, railings and paths, all of which had been introduced in the greatest profusion in Mt. Auburn, gave way to continuous lawns and varied effects of trees and shrubs. This advance was due mainly to the good taste and enthusiasm of Mr. Strauch, but credit should also be given to Mr. Probasco, a wealthy citizen of the same city and during many years President of the Board of Trustees of Spring Grove, who ably supported Mr. Strauch and helped him to overcome the opposition of the lot owners. In 1883 Mr. Probasco wrote a short account of the life and work of Mr. Strauch in which he said that "Spring Grove is perhaps the most important possession of the people of Cincinnati."

Since the information of our Association we have been endeavoring to follow along the lines pointed out by the creator of

this celebrated cemetery, always seeking greater simplicity greater naturalness, greater beauty. The selections given by our members on the calling of the roll, will indicate the line of our thoughts, so there is no need of reviewing our work in this paper. The system introduced at Cincinnati was called the "landscape lawn plan" and I think it would be admitted by all that the landscape is the leading feature in the modern cemetery. It is to this feature that I wish especially to call your attention.

Hammerton said: "A landscape means a piece of the earth's surface and it is always understood that this piece will have a certain artistic unity or a suggestion of unity in itself." A. J. Downing, the father of landscape gardening in this country, said "Our part, to appear to advantage, requires some extension of surface, its lines should lose themselves indefinitely and unite agreeably and gradually with those of the surrounding country." Loudon said: "The principles of landscape gardening we conclude to be derived from nature or developed from the principles of landscape painting." It would seem, therefore, that a study of the principles of landscape painting would be of material assistance to the designer who uses for his colors real foliage and flowers, or real trunks and branches of trees and shrubs, who gets his perspective effects from real distances, his lights from real sunshine, real skies and clouds or from their reflections in real skies and clouds or from their reflections in real water. While time cannot be spared to give all these principles, they may be briefly referred to. Ruskin speaks of them in the following order: First, the law of principality, which means that a composition should have some dominating feature to which all others are subordinate. Second, the law of repetition, in which a group or object in a view may be repeated by another group or object, but the repetition should not be exact. It should usually be different in scale and perhaps different in other respects so that the repetition is not too obvious. Third, the law of continuity, which is observed when there is an orderly succession of a number of objects more or less similar. Fourth, the law of curvature, and Fifth, the law of radiation, which have to do with the relative positions of the leading objects or lines with regard to each other. Sixth, the law of contrast. Seventh, the law of interchange, Eighth, the law of consistency. Ninth, the law of harmony. It is not often that we think of these laws when looking at scenery and we may not even know them, but when judiciously observed they help to make the landscape attractive. To be sure there are a great many points of view in a cemetery, and from every point new landscapes are seen. Then we have to consider the different seasons of the year, the different hours of a day, the various kinds of weather and the changes that will take place as years pass by, so we have something to study far more complex than a painting, but as it is more complex it ought to be made more interesting and satisfying; it ought to be man's most beautiful production, and what could be more appropriate for a resting place, a place to which so many are bound by ties of affection and remembrance? A landscape may be called the face of nature—of our mother earth. We should seek to give this face a good expression, an expression that pleases by its beauty, like the face of a beautiful child, and comforts in the way described by Lowell:

"The landscape forever consoling and kind,

Pours her wine and her oil on the smarts of the mind."

Another authority on landscape art, Thomas Whateley, says "The masses of light and shade, whether in a natural landscape or a picture, must be broad and unbroken or the eye will be distracted by the flutter of the scene." Is not this what happens when a beautiful lawn in a cemetery becomes covered with scattering monuments, headstones and flower beds? Compare the views to the right and left just after entering Spring Grove with that of the occupied portion of any cemetery, where



the quietness of the scene is disturbed by quantities of stones standing like gate posts with nothing to support. Compare the new portion of Greenwood, as we saw its beautiful grassy slopes some years ago, with that part covered with railings and sepulchral structures. In the latter case the eye is "distracted by the flutter of the scene." The following of French origin is applicable here :

"Insult not Nature with absurd expense  
Nor spoil her simple charms by vain pretense.  
Weigh well the subject, be with caution bold,  
Profuse of genius, not profuse of gold."

We are to hear later of The Cemetery as a Work of Art. Those artistic people, the Greeks, were told "by an unerring perception" as Prof. Butcher said, "that the beautiful must also be the true." As in conduct they insisted on an energy which was rational, so in art and in literature they required of beauty that it, too, should be before all things rational." A thought in the same line has been expressed thus, "In all the arts which serve the use, convenience or comfort of man, from gardening and building down to the designing of the humblest utensil which it is desired to make beautiful, utility and fitness for the intended purpose must be first considered." A cemetery serves the useful purpose of furnishing a place for the disposal of the dead, and by its artistic perfection it should comfort and satisfy the living. Upon purely rational grounds there is no excuse for the erection of mausoleums or the ordinary type of monuments.

In an account recently given of a new cemetery, after giving a glowing description of its advantages, the writer uses the following lines: "Not only is the civilization of a people expressed in the avenues of palatial homes and in the imposing edifices of commerce, but also in the condition of their places of sepulture. The tomb is to the future the witness of the present; it carries to posterity the records of a generation's ideals, whether they be high or low, debased or noble. In the monuments of the antique world we read the history of her tyranny, of her moments of enfranchisement and of her years of darkness; and the enlightenment of this age—the enlightenment of widespread education, charity and freedom—will not be less truly mirrored in the cemeteries which we establish and adorn and which we leave for the edification of posterity." I would ask, is there anything enlightening in many of the cemeteries of the present day? Will posterity respect us more when they see a wilderness of meaningless monuments? What does such a cemetery express? It speaks only of the thoughtlessness and self-conceit of the generation it commemorates. The following incident shows how little the people think of the meaning of monuments. A lady, looking at a new mausoleum of Egyptian design, said she thought it very strange that a Christian, in putting up such a monument, should follow the architecture of a heathen nation. She had just erected an obelisk on her own lot.

While most of our members recognize the fact that monuments are out of place in a cemetery, and that the true beauty lies in an artistic landscape and not in the stonework or the formal flower beds, we must admit that the influence of our meetings and our efforts throughout the year extends to comparatively few. While some progress is made, the result we desire seems to be coming very slowly. There will come a time, however, when another step in advance will be taken. We have seen how progress in the past has been due to the energy and enthusiasm of one man supported by a few kindred spirits. We may look for progress in the future in the same way. Someone with artistic instincts, energy and enthusiasm, aided by public spirited citizens, will create a cemetery without blemishes. It will have a relation to the present cemetery similar to that of Mt. Auburn to the old churchyard. It will contain trees lasting longer than most monuments, and vistas lasting longer than

trees. There are many books and magazines at the present time calling attention to the beauties of Nature by their reading matter as well as their fine illustrations, that we are learning to appreciate more and more the good things of this world. The camera and the bicycle also help us to see many charming bits of nature. Some time all the charm of foliage and flower, sun and shade, open glade and cozy nook, lake and stream, cloud and sky, will contribute to the beauty of a cemetery that will be looked upon by succeeding generations as we look upon the paintings of the Old Masters. To mar a vista in it with a tombstone, a geranium bed or any other object not in harmony with the surroundings would be like putting a spot on the face of the Sistine Madonna. "Actions speak louder than words." An example is better than a sermon. In the progress toward better methods Mt. Auburn and Spring Grove produced great results. When an ideal cemetery is once established under favorable conditions, a cemetery in which beauty is the controlling motive, in which provision is made for perpetual care, for excluding monuments and other discordant objects and for continued intelligent supervision; its superiority over other cemeteries will be quickly recognized and its characteristic features imitated. Then another great step in advance will have been taken.

Secretary and Treasurer F. Eurich read his annual report which showed an increase in membership of 14 and a prosperous financial condition. The present membership is 139.

Papers read at the morning session were "Review of Richmond meeting" by Charles W. Hamill, of Baltimore, Md., and "Foreign Funeral Customs," by L. L. Mason, of Jamestown, N. Y. An informal discussion on the admission of bicycles in cemeteries was exceedingly animated. Two-thirds were in favor of admitting cyclers under certain restrictions. Those who opposed their admission, even under restrictions, did so from various reasons, in most instances because the privilege had been abused.

In the afternoon carriages drawn by coal black horses conveyed the party to the leading cemeteries, Bellefontaine and Calvary, by a route that took in many points of interest. Bellefontaine



BROADWAY ENTRANCE, BELLEFONTAINE CEMETERY.





BROADWAY ENTRANCE, CALVARY CEMEIERY.

contains about three hundred and fifty acres of land picturesquely situated with its alternating woods, lawn and shady ravines. Its beautiful trees attracted very general interest. Although many lot inclosures are to be seen in the older parts they are now prohibited and more natural effects encouraged. Calvary, which adjoins Bellefontaine, is topographically similar in character. It contains five hundred acres, much of which displays the skill of the landscape engineer. The visitors were given an opportunity of examining Supt. Brazill's system of records and an exhibition was given of the workings of the electric signal bell situated near the center of the grounds. The signals are given from the entrances, half mile from the bell tower and greatly expedites the movements of the workmen. Probably the most notable monument in Cavalry is that which marks the resting place of Gen. W. T. Sherman, it is a granite shaft, pyramidal in form with crossed flags carved in high relief on the face. Secretary Gazzam, of Bellefontaine, and President J. B. C. Lucas and Supt. Brazill accompanied the party and directed attention to points of interest.

At the evening session, a number of interesting extracts from various publications were read by members as they responded to roll call. Mr. J. Y. Craig, of Omaha, Neb., read an account of the formation of a State Cemetery Association for the purpose of disseminating helpful information in regard to the improvement of cemeteries. The association has a membership of twenty-five and much interest is already being manifested in the new association.

"The life and works of John J. Smith," was the subject of an interesting paper by Mr. Geo. M. Painter, of West Laurel Hill Cemetery, Philadelphia. Mr. Smith was one of the founders of Laurel Hill Cemetery, Philadelphia, in 1835, the second

oldest rural cemetery in the United States, Mt. Auburn, at Boston, having been dedicated a short time before. In his early advocacy of suburban cemeteries he met with much opposition from the clergy who were loth to give up their church-yard burying grounds. He was an advanced thinker on the improvement of cemeteries and advocated that which would enhance the landscape, at the sacrifice of the commercial features in which respect it is to be regretted that his example is not more generally emulated. He died at the age of 83, a highly respected citizen of Philadelphia.

## SECOND DAY.

At the morning session the Hon. R. Graham Frost, a St. Louis attorney delivered an address and papers were read as follows: "Roads in Cemeteries where Macadam is too Expensive," by S. W. Rubee, Marshalltown, Iowa; "Advantages of Nurseries and Greenhouses in Cemeteries by John Reid, Detroit, Mich.;" "The Cemetery as a Work of Art," by Mrs. Fanny Copley Seavey. "Benefits from Attending meetings of our Association," by J. R. Hooper, of Richmond, Va., and "Drainage," by H. F. Torry, of Jersey City, N. J. Mrs. Seavey, whose name is familiar to all of our readers, gave the convention what was conceded to be one of the finest papers ever read before the association, it will be published in full in our next issue.

Geo. H. Scott, of Rose Hill Cemetery, Chicago, exhibited plans of a new chapel, conservatory and receiving vault to be constructed in his cemetery and read a carefully prepared description of the proposed structure. The design is of the Gothic order, and the appointments modern throughout. The building will cost \$50,000. A paper not announced on program, but which struck a sympathetic chord, was read by Mr. Wm. Stone, of Pine Grove Cemetery, Lynn, Mass., as follows:



FLORISSANT AVENUE ENTRANCE, CALVARY CEMETERY.



## WHAT A MODERN CEMETERY SHOULD BE.

The Modern Cemetery! What does it mean? It means everything possible to lighten the grief of those who are called upon to part with some dear one. How is this brought about? It is brought about by keeping the grounds neat and attractive, clean avenues, well kept lawns and lots, trees and shrubs in variety, flower beds here and there, and a superintendent who is in touch with everyone, easy to approach, sympathetic in nature, courteous at all times. Let these conditions be brought about, and we have what a modern cemetery should be.

When the dead has been laid to rest in its bed of mother earth, and the greensward has been replaced, and tender hands have arranged the flowers on nature's carpet, and the friends depart, they feel as if the modern cemetery had robbed death of half its horrors.

Compare the grave yards of the past with the cemeteries of to-day, and mark the progress. An extract from the *American Gardening* says: The tendency of the times is to make the cemetery a park, rather than a marble yard. Ghosts have vanished with old fashioned head stones, with skull and cross bones, and poetic epitaphs.

To-day, our cemeteries are called gardens of the dead, and the work is still going on in the direction of beautifying grounds that are now beautiful. And for this reason, our association was formed. Those who have attended our conventions have certainly been benefited. Whatever one's occupation, he will never make a success unless he loves his work. The superintendent should understand the construction of avenues and lawns, should know the name and nature of trees, shrubs and flowers, and not be obliged to ask any man of his employ. He can only learn this by practice and study. Books and papers are always in his reach, touching upon every subject of interest to him. We read of some experiment tried, or some idea advanced, just what we wanted to know, and we at once avail ourself of the courtesy of our unknown friend. The catalogues issued by our leading seedsmen, are full of valuable information. The mouthpiece of our Association, the PARK AND CEMETERY, has enlightened us on many a subject, and has done much towards educating the superintendent in the better discharge of his duties. It is still in its infancy. Long may it live and flourish, and continue to instruct us and those who may follow in our work.

Let me read an extract from Downing's Essays, and see what a master mind said nearly fifty years ago. One of the most remarkable illustrations of the popular taste, in this country, is to be found in the rise and progress of our rural cemeteries. Twenty years ago, nothing better than a common grave yard, filled with high grass and a chance sprinkling of weeds and thistles, was to be found in the Union. If there were one or two exceptions like the burial ground at New Haven, where a few willow trees broke the monotony of the scene, they existed only to prove the rule more completely. Eighteen years ago, in 1831, Mount Auburn, about six miles from Boston, was made a rural cemetery. It was then a charming natural site, finely varied in surface, containing about 80 acres of land, and admirably clothed by groups and masses of native forest trees. It was tastefully laid out, monuments were built, and the whole highly embellished. No sooner was attention generally roused to the charms of this first American Cemetery than the idea took the public mind by storm. Travelers made pilgrimages to the Athens of New England, solely to see the realization of their long cherished dream of a resting place for the dead, at once sacred from profanation, dear to the memory, and captivating to the imagination. He then speaks of the leading cemeteries of New York and Philadelphia, and says the great attraction of these cemeteries to the mass of the community, is not in the fact that they are burial places or solemn places of meditation for the friends of the deceased, or striking exhibitions of monumental

sculpture, though all these have their influence. The true secret of the attraction lies in the natural beauty of the sites, and in the tasteful and harmonious embellishments of these sites by art. It awakens at once the feelings of human sympathy, and the love of natural beauty, implanted in every heart. He then says in the absence of great public gardens, such as we must surely some day have in America, our rural cemeteries are doing a great deal to enlarge and educate the popular taste in rural embellishments. They are for the most part laid out with admirable taste. They contain the greatest variety of trees and shrubs to be found in the country, and several of them are kept in a manner seldom equaled in private grounds.

Since these lines were written, rapid strides have been made. Parks have sprung up all over our country, and no doubt many a hint was obtained from our cemeteries. Then lawn mowers were not invented, and of course lots did not present so smooth an appearance as now. The *Modern Cemetery*, a few years ago, said, more monuments are not necessary, but may be admissible under the lawn plan. Head and foot stones, however, should be abandoned and not allowed under any conditions. They are the multitude of closely huddled stone piles that obliterate and destroy the beauty of any landscape, natural or artificial. Only by concerted efforts, and by a display of good taste under the guidance of one controlling plan, can proper effects be secured, and the cemetery given unity in an endless variety, and yet be in harmony with its distinct purpose of burial.

I will add to this by saying that no fence nor structure of any kind should be allowed to enclose a lot, or corner post allowed above the grass. I am pleased to say that fences are constantly being removed as soon as the consent of the owner can be obtained. I understand in some cemeteries, the consent of the owner is not asked. In my own case, I get the consent of the owner, and, in some cases, it has been reluctantly given, feeling that it would be regretted, but I have found only one case where it was regretted: but on the other hand, they have wondered why they did not have it done before. I have taken down four this year, and have only 28 more left in the cemetery, and am in hopes, inside of three years, that not a fence will be left. There are only 10 lots enclosed by stone curbing in the cemetery, and one of those will be taken away before long. The graves on our public or free lots are marked by numbers on the end of a marble block set level with the grass. No other stones are allowed. Thus we are gradually working towards the lawn plan, and gradually working towards the perpetual care system. Some cemeteries sell under both, perpetual care or not. I sell nothing only under perpetual care. Any cemetery that sells lots to-day without the perpetual care system, will at some day regret it.

A carpet of green is the beauty of the cemetery, and let us remember that we cannot have that unless we start right, and I will not enter into the details of making a lawn, because you all know. The kind of grass seed used may vary with the locality. But one thing is certain—anything that is worth doing, is worth doing well.

How beautiful the trees! Weirs cut leaf maple, with its foliage touching the grass. The cut leaf birch with its white branches, in lovely contrast with the foliage. The purple and other varieties of maples, the purple beech, and the giant oak with its outstretched branches, that have defied the elements for generations. The many varieties of evergreens, and many varieties of our native trees that I will not mention, all contribute to make our cemeteries what they are.

Again, I will quote Downing. He says: An American may be allowed honest pride, in the beauty and profusion of fine forest trees, natives of our western hemisphere. North America is the land of oaks, pines and magnolias, to say nothing of the lesser genera and the parks and gardens of all Europe owe



their choicest sylvan treasures to our native woods and hills.

Let us not forget the flowers that do so much to beautify our cemeteries. Some have discouraged growing them to such an extent as they are grown in many cemeteries. To my mind, their many colors help to bring out the beauty of the grass, and make the lawn more beautiful. Who does not love them? They are welcome on every occasion, at the scene of festivity and the house of mourning. We watch them flourish under the hand of cultivation. We see them by the wayside, and in the fields, and up among the hills and mountains, cultivated only by the hand of nature, and we love them everywhere. They seem to carry with them something unexplainable, a sort of Divine inspiration. As I see people wending their way to the grave of some dear one, with a bouquet culled from among the treasures of the garden, I think what else would answer in the place of those flowers, and I answer myself by saying nothing. They seem to be a message to the departed one, and as far as we know, they may be in some way. Let us do all we can to encourage their growth, and not think for a moment, that they detract from the beauty of the lawn. I do not advise making a flower bed on the grave, preferring the grass and level at that.

I have always felt impressed that Sundays should be more generally observed in our cemeteries. I do not see why a superintendent should be called upon to sell lots on that day. The plea is made by people that they do not have the time on a week day. The office of the dealer in real estate is closed, and this plea is not made to them. Much other cemetery business is put off till Sunday by lot owners because they know the cemetery is open for business. Why make burials on that day, when the cemetery is full of visitors? To see strangers almost mingling with the mourners around the grave, is, to my mind, a scene not in keeping with what should be one of great solemnity. If for no other reason, a burial should not be made on Sunday.

In some cemeteries connected with our large cities, if it is necessary to make burials on Sunday, by reason of the large number of bodies brought in, means should be taken to prevent a public exhibition.

In the cemetery that is in my charge, from one to five bodies are brought in on Sunday, and they are placed in the receiving tomb, and arrangements are then made with whoever of the family that wish to be present at the burial, which is generally on Monday and not later than Tuesday. My assistant, or myself, is present at every burial.

I have no applications to sell lots on Sunday. My office is closed and the curtains down. A sign in the window informs visitors that the superintendent and his assistants are prohibited from performing any labor on the Sabbath Day, and is signed by the Secretary of the Board of Commissioners. An officer is on duty to answer all questions. Observing the Sabbath, I think is as much an improvement to uphold the standard of the modern cemetery as the many improvements that have been made in other directions.

In conversation with people, and hearing their expressions, I am firmly convinced that our cemeteries, in the manner they are kept, do much in the direction of education towards a higher standard of thought, and it is certainly pleasing to know that when the inevitable comes, our mortal remains will go back to dust in such beautiful grounds. A common interest is centered in our cemeteries. The young and the old walk hand in hand through the grounds. We see one standing in silent prayer by the grave of maybe a mother, who has fulfilled her mission, leaving a legacy rich with good teachings ere she journeyed to the Great Beyond. We look about the cemetery, and we see others standing by graves, and in their imagination, they have gone to that Great Beyond, and have seen father, mother, brother or sister. Could they walk out of the grounds feeling other than better by their visit?

Let us, therefore, strive to help our Association, and we will by so doing help ourselves, and see more readily where we can make improvements, never forgetting that this is an age of progress, and we must ever be on the alert. By so doing, we will make our grounds more attractive, and will be rewarded by the appreciation of a generous public.

The committee on State Association presented resolutions expressing sympathy with the Nebraska State association, extending co-operation in furthering the work of disseminating information on the care and improvement of cemeteries and recommending the formation of such societies in every state in the Union.

A letter was read from Mr. Charles Nichols, of Newark, N. J., familiarly known as Father Nichols, expressing regret at his enforced absence, this being the first convention of the association that Mr. Nichols has not attended; a suitable resolution was adopted and its substance telegraphed to him. The carriage route for the afternoon drive was through the beautiful residence district of the city to Forest Park and Tower Grove Park, and a portion of the cyclone district. Like the drive of the preceding afternoon, this was exceedingly delightful, the only cause for regret being that more time could not be spent with our courteous friend, Mr. Gurney, at Tower Grove Park. For the evening, through the courtesy of Prof. William Trelease, director of the Missouri Botanical Garden, the convention attended the 7th annual banquet to Florists, Nurserymen and Market Gardeners provided for in the will of Mr. Henry Shaw. The banquet was held at the Mercantile Club and was a most enjoyable affair, beautifully decorated tables, a delicious menu and a feast of reason and a flow of soul, made the occasion a memorable one.

#### THIRD DAY.

The morning session opened with a paper written by B. D. Judson, of Troy, N. Y., entitled "A Plea for the Perpetual Care of Cemeteries and their Individual Lots." Mr. Judson's plea was well stated and was followed by a helpful discussion of the subject of perpetual care.

Prof. J. B. Johnson, of the Washington University, St. Louis, read an intensely interesting paper on "A More Rational View of Death," in which he viewed death as a product of natural causes, and a friend and benefactor to the race. Cemetery superintendents, he said, can do much towards impressing upon the public mind that death is a friend and not an enemy.

A paper on "The Education of Lot Owners," by Matthew P. Brazill, of Calvary Cemetery, St. Louis, was an urgent appeal for co-operation on the part of the lot owners with the trustees so as to bring about much needed reform. He said in part: "The finest cemeteries are those that have



the strictest rules and insist on their observance without fear or favor, while those that allow lot owners too much of their own way are unsightly. Prospective lot owners should provide ample grounds for their places of sepulture which they could well afford to do if economy were exercised in funeral expenses and useless and unnecessary stone-work. The improvements in cemeteries must be conducted under one general plan dictated by educated taste. If we are to have harmony, individual rights must be subordinate to this general plan. This is obtained only where cemetery authorities have complete control, otherwise confusion reigns and the stone-yard supplants the lawn and the garden. Subordination, so necessary in the walks of life is equally requisite in the habitation of the dead."

In the discussion which followed, Mr. McCarthy urged the adoption of all good rules at once and their immediate enforcement. The way to resume is to resume; the time to begin our cemetery reforms is now. The closing paper was on "Fertilizers," by D. Woods, of Homewood Cemetery, Pittsburgh, Pa., which was read by the Secretary.

Appropriate resolutions were adopted in memoriam of those members who had passed beyond the vale during the past year; Geo. E. Renshaw, Bay City, Mich.; James Hargreaves, Kingston, N. Y.; John Betson, Philadelphia, Penn., and Meredith Cooper, Springfield, Ill.

Cincinnati was selected as the place of meeting in 1897, and the following officers were elected for the ensuing year: President, George W. Creesy, "Harmony Grove" Cemetery, Salem, Mass.; Vice-President, Arthur W. Hobart, Lakewood, Minneapolis, Minn.; Secretary and Treasurer, Frank Eurich, Woodlawn, Toledo, Ohio; Executive Committee, Wm. Salway, Cincinnati, Ohio; J. C. Cline, Dayton, Ohio; J. J. Stephens, Columbus, O.

In the afternoon two gaily decorated trolley cars conveyed the party to the Missouri Botanical Garden where several hours were spent most pleasantly and appropriately in strolling over the beautiful grounds. Many note books were in evidence, and Prof. Trelease and his courteous assistants were kept busy answering questions. Lunch was served on the lawn, during which time a mandolin orchestra discoursed sweet music. It was certainly a most delightful occasion and a fitting ending to one of the most successful meetings of the A. A. C. S.

#### Convention Notes.

Six of the original charter members were present: O. C. Simonds, Chicago; George W. Creesy, Salem, Mass.; F. Eurich, Toledo, O.; J. C. Cline, Dayton, O.; John Reid, Detroit, Mich., and R. S. McFarland, Lawrence, Kas. Mr. Creesy

and Mr. Eurich have the distinction of having attended every meeting of the Association.

\* \* \*

There are a few of the beautiful souvenir programs of the convention left. Copies may be had by addressing Mr. M. P. Brazill, Superintendent Calvary Cemetery, St. Louis, Mo.

\* \* \*

Superintendent Brazill made an excellent chairman of the Executive Committee and was indefatigable in his efforts to make the meeting a success. The meeting was pronounced by all to be one of the very best the association has held, and in some particulars unsurpassed.

\* \* \*

Mrs. E. E. Hay, Supt. of Erie Cemetery, Erie, Penn., the first of her sex to be enrolled as a member of the association was given a cordial welcome.

\* \* \*

Quite a few of the ladies are becoming as regular in their attendance as the most devoted superintendents, and now that Mrs. Seavey has broken the ice would it not be well to give the ladies a place on the program hereafter?

\* \* \*

Sid J. Hare, of Kansas City, took a number of snap shots, some of which may appear in these pages next month.

\* \* \*

An interesting exhibit of photographs from various cemeteries was made. This is a feature that should be encouraged.

#### Trees.

The following extracts from *Meehan's Monthly* for September are of interest:

Some kinds of the pine family have cones that stand erect on the branches; and when they are mature, have the scales drop apart, leaving the central axis standing on the branch. Others have the cones pendent, and remain entire even when gathered from the tree. The latter are called spruces, and the former firs. Besides this the firs usually have the buds covered with turpentine,—while the bud of the spruces are usually scaly.

In the vicinity of Philadelphia they have a fashion of lifting large trees where the grade has been raised that does not seem to be in practice elsewhere. Two ropes are attached to the top of the tree so that each can be drawn in different directions. A trench is dug around the base of the tree,—the circle being as wide as may seem judicious. When dug to the depth desired the earth is forked away from the ball, on one side, and a block set under the roots as a sort of fulcrum. The rope on that side is drawn over the block, and the result is the lifting up of the mass of roots on the opposite side. A little earth is then placed under these elevated roots, and the opposite rope drawn to that side. This lifts the roots over the block and more earth is placed there. The tree by the aid of the opposite ropes is then drawn backwards and forwards, more earth being placed at each turn. In a very short time the tree may be elevated as many feet as may be desired, standing on the summit of a firm mound of earth. Trees 25 to 50 feet high, with trunks 12 to 18 inches in thickness have been lifted in this way with very little check to future growth.



## Belle Isle Park, Detroit, Mich.

The park and boulevard system of Detroit, Mich., has been receiving considerable intelligent attention the past few years, and besides the maintenance of its four large parks and squares, with the very many im-



LOOKING DOWN CENTRAL AVE.,  
FROM CASINO.

provements constantly being carried out, the boulevards now in course of completion form a prominent feature of the system. In order to harmonize with the advanced views on boulevard improvement, a leading eastern landscape architect was engaged to prepare plans and advise on the new portion of the work, a course which will undoubtedly result in a harmonious and effective design which will grow in beauty as time passes along, and serve to prove the wisdom of submitting to the highest authorities landscape work of a permanent character.

The community has been very fortunate in having public spirited citizens to whom is due considerable park area, having permanently interesting features; and besides, Detroit has occupied a prominent position in the history of the country centering about revolutionary days, and the subsequent



CASINO LOOKING EASTERLY.

troublesome times of the war with England in 1812.

The gem among the city's parks is unquestionably the one situated in the river, of wonderful commerce, that flows past her doors, called Belle Isle, of which is herewith given a map and several views.

This beautiful island, containing some 700 acres, was originally called by the Indians Mah-nah-be-zee, or the Swan; while the French gave it the name of Isle St. Clair, from its position at the entrance to Lake St. Clair. It was so infested with rattlesnakes at an early day, that the English commissary department, both for convenience and to rid the place of these reptiles, placed a drove of hogs on the Island, which increasing so much led the French to call it Isle au Cochon, or Hog Island.

This name it retained until at a picnic party on July 4, 1845, it was named Belle Isle in honor of the ladies present. Reverting to its history, it appears that both under French and English control it was considered as belonging to the Fort at Detroit and during the revolution, prisoners were employed here cutting wood. The date of the first individual title to the island is 1769, when Lieut. McDougall bought it of Chippewa and Ottawa Indians, bought for eight barrels of rum, three rolls of tobacco, six pounds of vermilion and a belt of wampum, supposed to represent \$1,000. From his heirs it passed by sale to Wm. McComb, to whom title was confirmed by the United States in 1809. In 1817 it was sold to B. Campau, a well known name in Detroit, for \$5,000, and in 1879, one hundred and ten years from the date of its first sale it was sold to the city of Detroit for \$200,000.



A WATER SCAPE.

The island has always been a beautiful spot, even in the wildness and comparative solitude of its early days; but when it was acquired by the city for park purposes, a plan of improvement was prepared by Frederick Law Olmsted and carried out under his direction. Thus its natural beauties were developed and emphasized, and the island supplied with the necessaries of the public park. Since its acquisition there has been expended up to 1895, \$1,300,000, which includes first cost, improvement and maintenance.

The map shows the salient features of the island as a park, but it cannot show the varied beauties or the impressions created by such diversity of wood and water; the white capped river with its ceaseless commerce moving swiftly by, the still lake and silent streamlet, the solitary woods and the broad meadow,—enchancing vistas or wider views,



LOOP CANAL, LOOKING NORTHERLY

each and all presenting pictures of endless charm as sunshine and shadow succeed each other. Add to all this the artistic arrangement of landscape effects as designed by a master hand, to-





MAP OF BELLE ISLE PARK, DETROIT, MICH.

gether with appropriate structures to diversify the scene and supply the necessities of recreation or comfort of the visitor, and the possibilities of realizing an ideal park make themselves more apparent according to the intelligence supplied in its management and improvement.

The park is supplied with every feature for recreation, amusement or pleasure, and every year sees additions and improvements completed or inaugurated. Its large area and diversified landscape makes it popular with all classes, and while access is had from the city both by a permanent bridge and ferry, another bridge is under consideration to improve transportation facilities and this is also to accommodate car tracks, to give quicker transit right on to the ground.

It will be observed that water privileges are abundant, and that besides the surrounding river, there is a large lake area well distributed on the island, for the most part connected by canals, as well as communicating with the outside river itself. Every facility is offered for bathing and boating even as to moderate charges, which might well be imitated in other parks elsewhere, where such charges are often extortionate.

The bath houses are supplied with every requisite for both sexes, and the charge for room, bathing suit and towel is ten cents, for suit with use of locker only five cents is charged. The use of the public room is free. In the season there

is a daily average of seven hundred bathers.

The water in the canals and lakes varies in depth from one and a half to two and a half feet so that boating is perfectly safe, and the two boat houses have an unlimited supply of boats. Boats with cushions are rented for fifteen cents for first hour and ten cents for each additional hour; boats without cushions cost ten cents per hour for the first hour or two and 5 cents per hour afterwards—charges that place boat riding within the reach of all.

The park is supplied with wagons and pony carriages.

Pavilion Lake is kept clear of snow in winter and becomes a very popular skating pond.

The zoological department is growing. There are deer, elk and fox enclosures and paddocks, and the menagerie is acquiring additions at frequent intervals.

There are lawns and meadows for the various popular sports and amusements and the pavilion is also a refreshment room where light refreshments may be obtained.

An electric light system is maintained which adds materially to the charms of Belle Isle, and makes the park a delightful evening resort. Altogether there is a completeness about this public pleasure ground which makes it as of special interest, and replete with useful suggestions.



DEER PARK.



## Garden Plants,—Their Geography. XI.

## GERANIALES.

## THE GERANIUM, CITRUS AND CEDRELA ALLIANCE.

(Continued.)

*Dictamnus*, "gas plant," so called, is monotypic but in two or three shades of color. It is a capital garden plant, enduring, and raised from seeds sown as soon as ripe, but often lying a year before germinating. It is a native of Southern Europe and Western Asia.

The tribes Diosmeæ, Boroniæ, &c., contain a number of beautiful South African and Australian plants which should be of use in California.

*Zanthoxylum* with 110 species is a largely tropical genus, but *Z. Americanum*, *Z. clava-Hercules*, and two others are natives.

*Phellodeudron* has 3 species from Japan and Mandshuria. *P. Amurense* is hardy north to the lakes.

*Ptelea* has 7 species all North American and Mexican. *P. trifoliata* is known as the "hop tree" and has a yellowish leaved form.

*Skimmia* has 4 species from the Himalayas and Japan. *S. Japonica* is said to be used in the Boston parks, but it is little used elsewhere. It is a little evergreen shrub, sometimes with variegated leaves. If the two sexes are grown some of them will bear scarlet berries. There are several varieties catalogued as species in cultivation, and some are kept in southern nurseries. *S. laureola* is Himalayan.

*Murraya* with 4 species from tropical Asia and Australia is one of the most beautiful and fragrant shrubs in existence. It is in South Californian gardens but should never be exposed to frosts, of which it is more impatient than the orange. For some reason greenhouse gardeners persist in treating this beautiful thing to greenhouse treatment, when as a matter of fact it requires the temperature of a Palm house to flower and grow it well, and a rather dry rest at a temperature higher than the orange. *M. exotica* is the most free to flower, *M. paniculata* is in gardens too, and used to be sold for the smaller more valuable kind.

*Egle* is a genus of fruiting shrubs in 2 or 3 species. They are natives of Japan, China, India, the Indian Archipelago, and tropical Africa, and are widely cultivated and sometimes naturalized in other tropical regions. *Æ. sepiaria*, cuts of which can be examined in Nicholson, and also in Berckman's catalogue, is widely advertised under such names as *Triphasia trifoliata*, *T. monophylla*, *Limonia trifoliata*, *Citrus trifoliata*, &c. It varies in foliage and habit and in the color and size of its fruit just as the orange does, and the various kinds have berries from the size and color of choke-



CITRUS TRIFOLIATA.

cherries to the size and color of a small lime. They are famous hedge plants in warm countries, and fruit abundantly from Georgia southwards. The

forms with reddish fruit are probably more tender than the so called "hardy orange" with orange yellow fruit, which has been known to endure several winters in Central Park, New York, but gets frozen at last, and cannot be relied on north of the Carolinas. *Æ. marmelos* is a well known East Indian fruit of larger size than the others. This revision is a recent one, and the work of the Kew Herbarium. It will now be in order for the Fads Botanists to try and upset it.

*Citrus* has 25 species natives of the East Indies and Australia, but very widely disseminated in cultivation, and frequently naturalized in countries to which they have been carried. Orange seeds often grow up during summer in Northern gardens, but as the plants invariably freeze during winter, no one is betrayed into error from the circumstance. At the south they endure for a series of years and bear fruit, only to succumb to a winter of exceptional severity. Naturally they grow where the temperature never falls below 40 degrees Fah. *C. Japonica* the "Kumqua" is a



CITRUS AURANTIUM.

—Bahia Variety.

fairly hardy garden "species." Robert Fortune who presented a quantity of Chinese and Japanese seeds to an estate I once managed stated that in Japan it endures 20 degrees or 22 degrees Fah. This "species" should be hybridized. The so-called "hardy orange" is of still greater hardihood and credited to the same country. Nursery cata-



logues confuse this plant with Limonia, but so also have Botanists confused Limonia. The Genera Plantarum makes them in two or three species all tropical. Lindley in his vegetable Kingdom 3, p. 458, speaks of Limonia laureola on the authority of Dr. Royle as being for "some months of the year buried under the snow" of the higher Himalayas. The newer dictionaries give from one to six species of Limonia and don't mention laureola under the genus at all. Johnson's Garden Dictionary however in its last two editions gives the plant with its synonymy as Skimmia laureola. I mention these facts to show that plant names cannot be taken for granted in these days of evolutionary botany. Some limit should be placed upon Botanists. They are terribly misleading to nurserymen and gardeners and to each other, and a law to compel adherence to some recognized modern standard would be useful.

*Ailanthus* has 4 species in India, China and Australia. *A. glandulosa* in both its sexes has been widely distributed in the United States, but is often regarded as a nuisance because it suckers freely and smells offensively when in flower. *A. erythrocarpa* is also in cultivation.

*Melia* is in 12 species from India, Malaysia, and tropical Africa. *M. Azedarach* in variety has become naturalized in Mediterranean countries and



MELIA AZEDARACH.

the southern United States where it is known as the "umbrella tree." *M. Japonica* is also in gardens.

The tribe Trichiliae contains a number of handsome evergreen trees, such as *Aglaia* from India and China, *Ekebergia* from tropical and South Africa and *Trichilea* in 112 species from Africa, the West Indies and other parts of tropical

America. As these often ascend to considerable elevations on the mountains, they should be looked after for avenue purposes in Southern California. They are often embellished by racemes of fragrant white flowers.

*Cedrela* is a handsome genus of trees in 20 or more species from the mountains of India and other Asiatic countries, and also from tropical

CEDRELA SINENSIS.—From *Gardening*.

Australia and America. These again ought to be valuable to California for the purpose indicated above. A scarce and beautiful species with creamy white racemes is the only deciduous tree on the mountains of South India. *C. Toona* is a famous Himalayan timber, and *C. sinensis* of which we reproduce a photo from gardening, is hardy to central N. Jersey certainly, and has stood several winters much farther north.

*Swietenia mahagonia* is of a very similar aspect and a beautiful tree. It is reputed slow in growth, but I remember a specimen in Madras of 30 feet high at less than 25 years old. It is found sparingly in South Florida; the timber there is less valuable than in Centra America or in the West Indies, but a Mahogany Avenue is probably a possibility at Key West.

James MacPherson.

Trenton, N. J.

The gigantic lily is perhaps the most magnificent of Australian native flowers. From a cluster of graceful bending leaves rises a stalk to a height of from ten to fifteen feet, crowned with about a dozen crimson flowers, forming a kind of natural bouquet about a foot in diameter.



**Acceptable Grouping of Mixed Shrubs.**

The combination of shrubs in mixed groups or beds is a subject that all planters must needs study and be interested in, and the examples offered by such beds as are planned by Landscape Artists of standing can not fail to be helpful to Park and Cemetery men.

It is both interesting and instructive to note the shrubbery plantations already made in the permanent planting of Jackson Park, Chicago, after the plans of Messrs Olmstead, Olmstead & Elliot.

For instance, there are scattered throughout that part of the Park that has been improved this season, among others, 12 beds or groups containing 900 plants set three feet apart as follows: *Spiræa Thunbergii*, *Hydrangea Paniculata grandiflora*, *Deutzia crenata*, *Lonicera orientalis*, *Weigelia rosea* and *Rhodotypos Kerriodes*, 100 each; *Rosa rugosa*, Japan Quince, *Philadelphus coronarius* and *Spiræa Reevesi*, 50 each. These are all flowering shrubs, and the group will show bloom from earliest spring until frost, the most floriferous period being through May or June, or early part of July, according to the season. The arrangement of the plants is such that the early flowering Forsythias and scarlet Japan Quinces will make a lovely show in early spring; these will be followed by a long season of the white and rose colored flowers that predominate in the collection, and that flower in close succession through May, June and early July; and after these the *Rugosa* roses and the Japanese shrub, *Rhodotypos Kerriodes*, will probably supply some flowers, most years, until the showy panicles of *Hydrangea Paniculata grandiflora* open in August to furnish forth the groups for the remainder of the season.

Then there are more than one hundred beds made up of 32000 plants set two feet apart as follows: *Shrubby cinquefoil*, *Rhus copallina*, *Symphoricarpos occidentalis*, *Myrica cerifera*, *Rhamnus catharticus*, and *Prickly Ash*, each 2000; *Rosa lucida* and *R. nitida* 3000 each; *Spiræa salicifolia*, *S. tomentosa*, *S. opulifolia*, *Berberis vulgaris*, *Viburnum acerifolium*, 1000 each; *Berberis Thunbergii* 1800; *Ribes cynobati* 2500; *Bitter Sweet*, *Ilex verticellata*, *Straphylia trifolia* and *Choke Berry*, 500 each; *Cornus Sanguinea* 400; *Rhus aromatica* and *Aralia spinosa*, 100 each.

This collection includes flowering shrubs, those bearing ornamental fruits (notably the Bay Berry, Indian currant, Choke Berry and Buckthorn), those that give fine color effect in their fall foliage, and some that are conspicuous in winter by reason of their colored bark, notably *Cornus sanguinea*.

A less complicated combination is made up of thirty odd beds containing 5000 plants set two feet

apart, as follows: *Choke Berry* 1500, *Bay Berry* 2000, *Thunbergs Barberry* 1000 and *Hypericum prolificum* 500.

A still simpler grouping consists of 700 plants of *Lonicera Halleana* and 200 of *Rosa Wichuraiana* in nine beds of 100 plants each viz: two of the Japanese creeping rose to every seven honeysuckles, all set three feet apart.

Quite a different effect is obtained in fourteen plantations containing 2500 plants set three feet apart thus: *Black Alder*, *Silky Cornel*, *High Bush Cranberry* and common *Elder* 300 each; *Rosa Multiflora*, common *Lilac*, and *Amoor river Privet* 200 each; *Althea* 150; and *Syringa* (*Mock Orange*) 500. This combination gives several seasons of bloom and shows at all times harmonious foliage effects.

There are some twenty-five plantations of large shrubs and small trees aggregating 3300 plants set five feet apart in the following proportions: *Red Bud*, *Pennsylvania maple* or *Moose wood*, *Mountain maple*, *Arrow wood*, and *Hop tree* 200 each; *Sassafras*, *Cockspur Thorn*, and *European Mountain Ash* 100 each; *Flowering Dogwood* 150; *Shad Bush* 300; *Scarlet Thorn* 50; *Witch Hazel* 500; and *Stag Horn Sumack* 1000. There would seem to be material in this collection to make the groups attractive the year around. One has but to close ones eyes and imagine the *Dogwoods*, *Red Buds*, or *Thorn trees* in flower; the *Mountain Ashes* in fruit; the glory of the *Sassafras* trees and *Sumachs* in the fall, or the *Witch Hazels* tossing their yellow curls in November, to get some idea of the woodland wealth hidden in the mere lists of names given here. It seems to me a glorious combination, whether ideal or not I am unable to say now but I expect to find out by watching those groups next season.

A number of plantations contain both trees and shrubs, the trees being set twenty, and the shrubs three feet apart, about 10,000 in all, divided, I think, in eight beds in the following proportions, trees: *Betula papyracea*, *B. lenta* and *Quercus alba* 25 each; *Acer rubrum*, *Quercus rubra* and *coccinea* 50 each; shrubs: *Sweet Pepper Bush*, *Indian currant*, and *Viburnum dentata* 1000 each; *Prickly Ash*, 2000; *Cornus stolonifera*, *Amoor river Privet* and *Carpinus Americanus* 500 each; *Spiræa opulifolia* and common *Privet* 1500 each; *silky Cornel* 250.

These are only a part of the combinations seen, nearly all of which promise well. The most doubtful features are some of the plants indigenous to the swamps of New Jersey. These may take kindly to the sandy soil, but, as all other conditions are unlike those of their habitat, the results may prove unsatisfactory. The season has, however, been most favorable for planting and June of '97 will no doubt show a marked improvement in the appearance of what will always be to many of us the World's Fair ground of delightful memory.

Fanny Copley Seavey.



**Memorial Bust of Thomas D. Gilbert, Grand Rapids, Michigan.**

Much interest was always manifested throughout the work connected with the memorial bust of the late Thomas D. Gilbert, a distinguished citizen of Grand Rapids, Mich. Such a career of usefulness as that of Mr. Gilbert would place its exhibitor high on any roll of honor, and Grand Rapids is serving its generation well in perpetuating in so appropriate and excellent a manner the memory of so many years of able and effective work in the cause of her progress.

As the first president of its Board of Public Works, member of its Common Council, member of the Board of Education, Regent of the State University, member of the Legislature, and many other public functions extending over a term of thirty six years, at all times and in all things earning the respect of his fellow citizens, it was to be expected that the ceremonies attending the unveiling of a monument to his memory in Fulton Park would be entertained as quite an occasion by the enterprising city. That it was so, goes without saying, and many distinguished men of the state gathered with the multitude to pay honor to departed worth.

As will be seen by the illustration the setting of the monument is very effective, and exceedingly appropriate, from the fact that Mr. Gilbert himself had prepared the lawn and planted most of the trees

in Fulton Park, and its location brings it in view of numbers of people pursuing the ordinary avocation, of life.

The memorial consists of a bronze bust mounted upon a polished pedestal of Westerly granites from the Smith Granite Co., Westerly, R. I. The base is 5 feet 9 inches by 4 feet 9 inches and the total height to top of bust is fifteen feet. The pedestal weighs in the neighborhood of 18,500 pounds.

The bust, modeled by Lorado Taft, demands more than a passing word. On all hands it has received unstinted praise, Mr. Taft, having caught a likeness, that all who knew the original in life declare to be accurate and life-like. Moreover the work evinces a spirit which places it easily in the front ranks of works of art. It is not only in the modelling, which is exceptionally good, that this bust attracts attention, but there is life in the set of the features, and an expression that can be translated and be understood by the observer. This is where the sculptor, per se, displays himself and which distinguishes his



THE GILBERT MEMORIAL, GRAND RAPIDS, MICH.

work both from the copyist and carver.

The bust is heroic in size, and attracts the attention of all in its neighborhood. It will also be observed from the illustration that the treatment of the subject differs from the usual style of such work, and it is set upon the pedestal without mouldings or other additions. Altogether the monument is a high class work.



**Park Place, Henley-on-Thames, England.**

Nearly all who leave here for a visit to England know of Henley-on-Thames because of its famous regatta. The regatta is an annual occurrence, and attracts thousands of visitors to witness it. But there is another great attraction at Henley, known to a favored few, which is the splendid grounds of Park Place, the residence of Mrs. Noble. Mr. George Stanton, the gentleman in charge, has a



rare chance to display the ability he possesses, as the grounds, including the farm land, embrace 1000 acres, and excellence in everything is the order of the day. I had the pleasure of visiting the place in the summer of 1895, spending a whole day among its many horticultural charms. Space will not permit me to refer to but little besides some of the fine trees on the place, though it is with regret I omit reference to the numerous glass structures and their contents. There are so many nice broad-leaved evergreens in England that would so adorn our grounds would they but stand our climate. But some of our Pacific coast evergreens which the English use so much we could plant more largely of than we do. For instance, the *Thuja borealis*, stands perfectly about Philadelphia. Park Place has some fine specimens of it, and one variety, with golden foliage is a very effective sort. There is also a beautiful hedge of it, in length perhaps 200 feet. These is a variegated as well as a golden leaved variety.

The Cedar of Lebanon exists in some fine old trees at the Royal Garden, Kew, England, but for beauty I think the one at Park Place excels all others seen by me. It is about 100 feet in height and 4 feet in diameter. The Deodar cedar is not perfectly hardy in Pennsylvania, but the Mt. Atlas one, seems to be, and with the Lebanon is an excellent park tree for this country. The flowering ash, *Ornus Europæus*, is represented at Park Place

in a well proportioned specimen 40 feet high by 30 wide; when in flower it is quite ornamental, much more so than any tree of ordinary ash tribe.

American trees are scarce in England, but our Sweet Gum, *Liquidamber styraciflua*, was showing luxuriant growth in a specimen 50 feet high. *Pinus cembra*, which on account of its slow growth and erect appearance, is so much used in our cemeteries, was represented in a lovely specimen 35 feet high and 2 feet in diameter. The Colchican maple, *Acer lætum*, is a beautiful tree and entirely hardy in Pennsylvania, yet it is seldom seen in cultivation here. Mr. Stanton has a tree under his charge which is the largest I have ever seen. I did not measure its spread, but being of a round headed growth, much as the Norway maple is here, it was immense. Its trunk measured 3 feet in diameter.

Elms are of great size in England as they are here. There are some monsters near Richmond Park, near London, and at Park Place was a vigorous tree, still in full growth, which appeared to be fully 100 feet high, with a diameter of 5 feet.

At Park Place are many woods, which are either of natural growth or have been planted so long that the growth seems spontaneous. The paths through these woods have been nicely planted with shrubbery. The banks on both sides of one such a road contained *Hypericums* and other low growing, partly creeping shrubs, while on the edges of the woods were tall growing shrubs such as *Cotoneaster affinis* and our own *Spiræa ariæfolia*, the latter a good, late flowering white one.

Mr. Stanton's cottage is in the midst of lovely Park Place. Through the kindness of one of the ladies of his family, I was presented with a photograph of it. Your readers will see what a beautiful cottage it is. It stands in the centre of the grounds, near by the greenhouses, fruit houses and fruit gardens, and is so embowered in trees and flowers as to be a most charming residence. I may say that this cottage is but the type of many others seen throughout England. There are but few so pleasantly situated as this one, but the natural love for flowers the Englishman has and the opportunities the climate gives to foster this love, lead to many a home being tastefully adorned with vines and flowers as is Mr. Stanton's. *Joseph Meehan.*

The whistling tree is found in the West Indies, in Nubia and the Soudan. It has a peculiar-shaped leaf, and pods with a split or open edge. The wind passing through these makes a sound which gives the tree its name. In Barbadoes there is a valley filled with these trees, and when the trade winds blow, a constant moaning, deep-toned, whistle is heard from it, which at night is very weird.



## PARK NOTES.

A committee has been appointed by the people of Baxter, Ia., to provide park improvements for the town.

\* \* \*

An active revival in park interest is being manifested in Hazleton, Pa. Owing to the condition of the city treasury, no money has been available for maintaining and keeping the park in proper shape. In view of this condition of affairs the citizens are getting together and with subscriptions and voluntary labor, backed by the council, will carry out necessary improvements and put the park in better condition.

\* \* \*

A member of the council of Kansas City, Mo., favors giving persons of limited means a chance to invest their savings in park certificates. It was the intention of the park board to issue the proposed certificates in denominations of \$1,000 each, but it is believed they would find a more ready sale in smaller denominations, say, one-fourth of the denominations of \$100 each, one-fourth \$500 each and the remainder in certificates of \$1,000 each. This idea seems well worth developing.

\* \* \*

The West Side Park Commissioners of Chicago, have introduced a feature into Douglas Park, which redounds to their credit and excellent judgment. A natatorium and gymnasium combined has been constructed, architecturally attractive and furnished with every necessary appointment that could be desired. The public is entitled to the use of this establishment free of charge, and being situated within easy access of a crowded district, it will be a boon sure to be appreciated, as well as a civilizing agent of great importance. Such a step on the part of park authorities is worthy of imitation, and should be established in every large city park in the country.

\* \* \*

In his late message to the legislature, ex-Governor Werts, of New Jersey, thus epitomized the necessities and advantages of parks to a community: "The setting aside of tracts of land for public parks, as places of public recreation, rest and enjoyment, has come to be regarded as a necessity rather than a mere convenience. They conduce to the public health, promote the general happiness and encourage citizenship. As public investments they are remunerative and profitable. Experience has proved that the increased valuations in the vicinity of a well-regulated park will soon more than pay the cost of the original investment."

\* \* \*

Dyker Beach Park, Brooklyn, N. Y., will eventually be one of the most attractive parks to be found anywhere. It commands a magnificent view, covering Staten Island, the ramparts of Fort Hamilton, and the Jersey Highlands, in the distance, in addition to the charm of the grand Atlantic with its water traffic. This park is the only one of Brooklyn having a true ocean outlook with its beach accompaniment. Some of its features will be unique; it will have a salt water lagoon, fed daily from the Atlantic, bathing and boating facilities, and play grounds especially provided for the children. With the means liberally provided by a great city like Brooklyn, the future of this park as a pride and pleasure of the people should be positively assured.

\* \* \*

St. Louis, Mo., has twenty public parks and squares, comprising an acreage of 2180 acres. The principal tracts are: Carondelet Park, 180 acres; Forest Park, 1,375 acres; O'Fallon Park, 159 acres; Missouri Botanical Garden, 50 acres; Tower Grove Park, 267 acres; Lafayette Park, 30 acres, and Compton Hill Reservoir, 40 acres.

French's statue of the Republic, the last relic in place of the World's Fair, Jackson Park, Chicago, was intentionally destroyed by fire the latter part of August. It was rapidly falling into decay, and the cost of repairs, or of removing it, was beyond reasonable outlay, and it was decided by the Park Commissioners to destroy it in the way mentioned. Its magnificent modeling is preserved, however, in smaller sizes elsewhere.

\* \* \*

To December 31, 1895, the area of park property of the city of Cleveland, O., amounted to 1100 and a fraction acres. Since the above date other large areas have been donated to the city, very materially increasing this acreage. There are sixteen parks and parkways, the most important of which are: Garden Park 122 acres; Wade Park, 74 acres; Doan Brookway, 208½ acres; Brooklyn Park, 81 acres; Edgewater Park, 89 acres; Ambler Parkway, 55 acres; Newburgh Park, 156¾ acres; Shaker Heights Park, 279 acres. There was expended last year on improvements and maintenance of the park system, \$289,527.84

\* \* \*

Des Moines, Iowa, has acquired some 387 acres of land for park purposes, at a cost of \$128,000. The people of that state are conservative in finances, their policy being "pay as you go." While a good rule in most cases, it necessarily causes serious delays in the consummation of public projects. It has affected park affairs, and purchase and improvement both have to wait upon the proceeds of a two mill tax, which yields about \$32,000 per annum, to carry out the system. The legislation on park matters was enacted in 1892, and was succeeded by two years of litigation, with final result as above indicated. The four principal parks are: Greenwood Park, 81 acres; Grandview Park, 100 acres; Woodland Park, 190 acres; Union Park, 16 acres.

\* \* \*

A device for steam spraying conceived by Mr. Pettigrew, superintendent of Prospect Park, Brooklyn, is attracting considerable attention. The old hand pump method was totally inadequate to the economical and efficient spraying of large numbers of big trees, and the steam method was thought out. A tank wagon is combined with a portable steam pump and is thereby made to throw a stream of the fluid with practically the force of a fire engine. The tank holds about 600 gallons of water, and when the insecticide has been placed in it, it is necessary to keep the solution stirred to prevent the settling of the dissolved substances. The number of trees in Prospect Park make some wholesale method necessary. By this steam device the gang can spray a double row of high trees on the outer limits of the park, half a mile long, in one day, reaching the top of the highest of them with a good and effective stream.

\* \* \*

The new animal house for the zoological department of Lincoln Park, Chicago, combines the latest ideas connected with such structures, in addition to the special requirements dictated by climatic conditions. The design is after the Japanese displaying a picturesquely broken exterior. The building, or perhaps aggregation of buildings is 450 feet long by some 50 to 60 feet wide. Its many rooms are so separated, that either temporarily or permanently, different temperatures may be maintained to suit the inmates. It is expected that the central portion of the structure will be ready for the coming winter's use, and perhaps the whole building completed in the spring. The carnivora room in the centre will be 50 by 180 feet; on the sides of this are two rooms each 45 by 55 feet; one of these will be devoted to an aquarium and the other to the monkeys. Beyond again are rooms for the elephants, hippopotamus, reptiles, etc. Boulder stone will be used for the exterior and red tiles for the roof. The cost will be \$70,000.



## CEMETERY NOTES.

Twenty-three acres of the new Catholic cemetery at Lima, O., are under improvement, and the cemetery will soon be open for burials. The landscape work is intended to be a special feature.

\* \* \*

Colonel George Healy, who died last month at Rochester, Minn., and who was treasurer of Oakwood Cemetery Association of that city, has bequeathed some \$60,000 to the cemetery, the interest of which is to be used in beautifying the grounds.

\* \* \*

It has been decided by the city authorities that Greenlawn Cemetery, Indianapolis, Ind., shall be turned over to the Park Commissioners, who will endeavor to make it an ornament rather than a disgrace to the southwestern part of the city.

\* \* \*

Oak Grove Cemetery, one of the oldest of Kansas City, Mo., and completely filled, has been sorely neglected by the authorities, and its condition has aroused considerable feeling. This will undoubtedly result in some permanent method of maintenance for that and other of the city cemeteries.

\* \* \*

Scotland claims the credit of having the smallest burial ground in the world. It is situated in the town of Galashiels between Bridge street and High street. It measures only 22½ feet by 14½ feet, and is surrounded by a rickety wall about seven feet high. It has been closed as a burial ground for many years.

\* \* \*

One would hardly expect to find a burial ground within the boundaries of Prospect Park, Brooklyn, yet there still exists the old Quaker cemetery, hidden away, yet of considerable area, and carefully kept. Quaker simplicity and severity prevail throughout. The grass is carefully cut and trees and small shrubs abound. The headstones are uniform in height but quite low, and there is no ostentatious display anywhere about this quiet sequestered spot.

\* \* \*

Great improvements have been under way in Woodlawn Cemetery, Nashua, N. H., since its management went into the hands of a board of Trustees. In fact a transformation has been rapidly effected, and modern ideas and business methods have taken the place of the slipshod policy of years ago. In most of the town cemeteries the same careless methods of keeping records prevailed, so that it is difficult to ascertain particulars of interments or other matters of former days. Now this will be changed and cemetery business systematized.

\* \* \*

The Laurel Hill Association, Stockbridge, Mass., is the oldest village improvement society in America. It held its 43rd annual meeting on August 26. Its sustained energy has resulted in making Stockbridge well known all over the world as one of the most beautiful villages in the United States. One of its committees has charge of those parts of the cemetery where there are no resident friends to look after the graves. The association has also located a large number of revolutionary soldiers' graves and has had them properly marked.

\* \* \*

A new stone gateway is to be erected and other improvements carried out at New York Bay Cemetery, Jersey City. An interesting feature in regard to this cemetery is the number of Society lodges and other corporations that own lots therein. For instance there are some twenty lodges of the Odd Fellows; three

Masons; six churches, including three of New York City; two steamship companies; the American Dramatic Association; the Police department; the Mayor and Common Council, and several other associated bodies, all holding a greater or less number of lots for burial purposes.

\* \* \*

After an existence of nearly one hundred years, the old West Street Presbyterian Cemetery in Georgetown, D. C., is to be turned into a site for building lots. No interments have been made for ten years past. The trustees some time ago posted notices warning all persons having friends buried there to remove the bodies before September 1, since which date a force of men has been at work removing the remains to other cemeteries. Many well known men were buried here, but the place has been allowed to run down, and it became an unsightly grave yard.

\* \* \*

Lakeside cemetery, at Hamburg-on-the-Lake, nine miles from the City Hall, Buffalo, was practically opened last month by the visit of a large number of people, guests of the cemetery management, to inspect the new grounds. The tract comprises 250 acres, having a frontage of three quarters of a mile on the railroad, with Locksley Park and Lake Erie in the foreground. An adjoining tract of 120 acres may in the future be added to the grounds. The land has great advantages for cemetery purposes. The railroad station, a handsome structure, and which will also be used for the present as a chapel, is already built; a receiving tomb will be finished this fall and the chapel proper will be constructed at an early date. It will be completed and managed on the lawn plan, and it will be made a beautiful burial park.

\* \* \*

The U. S. National Military Cemetery at Knoxville, Tenn., comprises about ten acres of land, rectangular in form, enclosed by a rubble stone wall. The graves are arranged in concentric circles around a mound in the centre, where a flag pole stands, from which floats the flag presented by the ladies of Knoxville. Driveways intersect the cemetery from the four sides, with iron gateways on the east and west sides. A brick structure for a rostrum was erected in 1878, which is used by the G. A. R. annually on Decoration Day. A stone lodge serves as residence for the superintendent and office of the cemetery. Trees, shrubbery and flowers help to make the place attractive. The total number of interments are 3208 of which 2161 are known and are recorded on the headstones. "United States soldier, unknown," is the record on the headstone at 1047 graves. The remains were gathered from the surrounding states, with great care, but with the above result.

\* \* \*

The Board of Trustees of Pine Hill cemetery, Dover, N. H., has issued their first annual report for the year ending Dec., 31, 1895. This board of trustees was appointed last year under an act of the legislature, and was designed to put the town cemetery affairs under intelligent management, and to empower said trustees to secure additional land and improve it. Pine Hill cemetery originated under a vote at a public town meeting held March, 29, 1731, which reads as follows: "Voted that there be one acre & an half of Land Granted for the use of the Town for ever, for a public Burying place, To be Laid out by ye Select men near ye Meeting-house on pine Hill at Cochecha." No authentic records can be found of the location of this original one and half acres, nor of the subsequent many additions, up to the incorporation of the town in 1855. Since that time the record is clearer, but yet far from complete. With the adoption of the trustee system a new era opens up for Pine Hill Cemetery.



In tendering his resignation as superintendent of Woodland cemetery, to the Cemetery Committee of the city Council of Des Moines, Ia., Mr. T. B. Robinson, submitted in writing a number of suggestions, looking to the better regulation of cemetery affairs, necessary and immediate improvements, and changes in methods. Several of the recommendations were adopted with the prospect of all the suggestions being acted upon. From the tenor of the communication it would appear that like many other cemeteries managed by city common councils there is a lamentable lack of intelligent understanding of cemetery ethics, and this emphasizes the view that special committees should be appointed, where cemeteries are under municipal control, whose sole duties should be to care for the properties relegated to their management.

---

### Legal.

#### MONUMENT LIEN LAW HELD UNCONSTITUTIONAL.

A lien for \$1,363.67, balance of purchase price remaining unpaid on monument set up in Greenwood Cemetery, Brooklyn, New York, with interest from August 10, 1894, was sought to be established under the New York law of 1888. This statute declares that every person, firm, corporation, or association that shall furnish or place in any cemetery or burial ground any monument, grave stone, inclosure, or other structure may at any time, or within one year after the bill for the same becomes due, file with the superintendent or person in charge of such cemetery or burial ground notice in writing, signed by the vendor, to the effect that he claims a lien on the same for the purchase price thereof or such portion of the purchase price as remains unpaid, with interest. The superintendent or person in charge is to forthwith notify the owner of the plot of the filing of such notice of lien. In case the amount due be not paid within six months after the service of the notice on the plot owner, the person claiming such lien shall within 60 days have the right, on 10 days' notice to the superintendent or person in charge to remove the monument or other structure from the cemetery or burial ground, and shall advertise and sell the same at public auction to the highest bidder, to satisfy the lien. Because it deems the statute authorizes the taking of property without due process of law, which not only requires that notice shall be given to the person whose property is to be taken, but he shall have an opportunity to be heard before a court or properly constituted tribunal in a trial conducted according to law, the special term of the supreme court of New York City holds the statute unconstitutional and void. Not only so, but it also holds the owner of the lot entitled to a perpetual injunction against the parties seeking to enforce a lien under the statute, restraining them and their agents and servants from interfering with the monument in question. Under a valid law, creating a lien of this character,

it would seem from what the court further says, that from its very nature it would be so repulsive to the courts that they would permit no presumption in favor of those claiming a lien under it: and, unless they complied strictly with the requirements of the statute, if valid to serve on the owner of the lot a copy of the lien filed with the superintendent, without notifying him that the lien had been filed with the superintendent, and when.

#### RIGHTS IN LOUISIANA TOMBS.

While American law is regarded generally as a development of the English common law, Louisiana has a code founded on the civil law adopted by France. This apparently makes quite a difference as to certain rights in tombs and burial lots. The decision of the supreme court of Louisiana in the recent case of *Choppin v. Labranche*, will illustrate this. It maintains that cemetery lots do not part with the character of immovable property because devoted to burial purposes, and that the Louisiana code completely effaces the distinction of 'things holy, sacred, and religious.' As a consequence, there can be no modification of ownership of burial lots. And there is no servitude, or legal right of use apart from the ownership, established on property for the interment of the dead. Now what must be the decision of a suit brought by near relatives of deceased persons to prevent their remains being removed from a tomb in which a friend who had erected same promised they should have their final resting place, by the widow and legatee of such friend, who became the sole owner of the property with no form of subdivision of her ownership vested in any one else, and who proposed to sell the tomb? It is interesting to note how this court came to practically the same point, but by a wholly different way, as the courts of other states. It felt that, except in cases of necessity, or for laudable purposes, the sanctity of the grave should be maintained. But the usual reasoning could not be followed. The promise of sepulture in the tomb had been made and the remains of his friends laid therein during the lifetime and ownership of the party making the promise. The promise having been made and acted upon, the court found a basis for doing what it wanted to do, and held that, wholly irrespective of any issue of title, neither the party who made the promise could have afterwards in his lifetime recalled it nor could his legatee after his death, and require the removal of remains deposited on the faith of that pledge of final sepulture. Everything was rested on the promise. Consequently the court considered that all that could be done was to make the injunction perpetual as to the removal of the remains of those thus placed in the tomb, and would not prohibit a sale of the tomb.



### Association of American Cemetery Superintendents,

G. W. CREESY, "Harmony Grove,"  
Salem, Mass., President.  
ARTHUR W. HOBART, "Lakewood,"  
Minneapolis, Minn., Vice-President.  
F. EURICH, Woodlawn, Toledo, O.,  
Secretary and Treasurer.

### Publisher's Department.

Park Commissioners and Cemetery trustees are requested to send us copies of their reports.

Photographs and descriptive sketches of interesting features in parks and cemeteries are solicited from our readers.

#### Obituary.

Mr. Meredith Cooper, Superintendent of Oak Ridge Cemetery, Springfield, Ill., died September 9, from disease of liver and stomach, after an illness of about four weeks. He was a member of the Association of American Cemetery Superintendents and was looking forward with much interest to taking part in the St. Louis convention. Mr. Cooper was a man held in high esteem by his fellow citizens; a genial and cheerful disposition endeared him to many, and his funeral attested the position he had held in the community. For over ten years he had been superintendent of Oak Ridge, the cemetery wherein rest the remains of Abraham Lincoln, and he had earned and retained to the fullest extent the respect and confidence of its officials. He took a lively interest in cemetery development and in interesting others in the cause. His death has caused deep regret in the cemetery board. It is probable that the trustees will appoint Mr. John Gaupp, ass't. superintendent, to succeed the deceased.

Mr. John G. Barker, who has been taking a rest at Meriden, Conn., has written a letter to the local press in regard to the condition of its cemeteries with many suggestions specially relating to Walnut Grove, in which cemetery many of Mr. Barker's relatives are buried. From the tenor of the communication it would appear that this cemetery, although beautifully situated, is lacking in most of the requirements of the modern cemetery, and as might be expected Mr. Barker's suggestions, if acted upon as they should be, would make the cemetery more of a credit to the community and a place of increasing interest as its beauties developed.

The invitations from Henry A. Dreer, Inc., to join the Gardeners' and Florists' excursion to Dreer's Nursery, Riverton, N. J., on Monday, Aug. 31, met with a hearty response, some 1800 persons mak-

ing the trip. The new block of houses now in course of construction attracted much attention, they will cover one acre and will duplicate the block built last year. This house is intended for palms. The aquatics also formed a special attraction. After going the rounds of this large establishment, refreshments were served, photograph of the immense group taken, congratulatory speeches exchanged and the return trip made to Philadelphia. The firm of Henry A. Dreer started in a small way 40 years ago, and has steadily grown to the present extensive establishment.

"The Landscape Gardener in the Country" is the title of a paper contributed by Mr. F. H. Nutter, Landscape Architect, Minneapolis, Minn., to the September issue of the Minnesota Horticulturist. It is in line with the progressive thought on civilized landscape work, and deals also some heavy blows against the rectangular system of surveys, which while admirable from a utilitarian standpoint, has been the greatest detriment to the preservation of natural beauty on the sites of our cities and towns. The article contains many suggestions of value.

#### Received.

First Annual Report of the Board of Trustees of Pine Hill Cemetery, Dover, N. H., for the year ending December 31, 1895.

Third Annual Report of the Board of Park Commissioners of the City of Cleveland, 1895. Beautifully illustrated.

City of Malden, Mass. Report of the Park Commissioners, for the year ending December 31, 1895.

Second Annual Report of the Board of Park Commissioners of the City of Des Moines, Ia., 1895. Illustrated.

Fifth Annual Report of the Board of Park Commissioners of the City of St. Paul, for the year ending March 1, A. D., 1896. Illustrated with maps and half-tones.

Board of Administration. Annual reports, Park Department, Cincinnati, O. For the years 1894 and 1895. Illustrated with half-tones.

Annual report of the Parks-Commission of the City of Worcester for the year ending November 30, 1895. Illustrated with half-tones.

City of Walden, Mass. Report of the Park Commissioners for the year ending December 31, 1895.

First Annual Report of the Cemetery Board, New Bedford, Mass., for the year 1895.

Thirty-fifth Annual Report of the Department of Parks of the City of Brooklyn,

N. Y., and the first of the County of Kings for the year 1895. A beautifully illustrated book of 167 pages.

#### CATALOGUES.

Catalogue No. 1. Fruitland Nursery, Augusta, Ga. P. J. Berckmans, proprietor. Descriptions, illustrations and prices of a large assortment of Fruit and Ornamental Trees, Roses, Shrubs and Plants.

G. D. Shimer, Bangor, Pa., manufacturer of slate vaults and catacomb shelves, draws attention to the commendable advantages of Slate Grave Vaults, especially the grooved and bolted vault, a cut of which appears in his advertisement in another column. These are made entirely of slate in six pieces, grooved together so firmly that they are self-sustaining and are rendered perfectly watertight by using cement in the grooves. This vault is used instead of a walled grave, and renders wooden cases unnecessary, as all who know of the strength and durability of slate will appreciate. Mr. Shimer does a large trade in catacomb work, and being close to a fine quality of slate with ample facilities for manufacturing, he is able to produce the best of work at minimum cost.

The De Kalb Fence Co., De Kalb, Ill., are not complaining very much on account of hard times. The sale of its product for the season just passed has been the greatest in its history, and an increase in capacity has been imperatively demanded. This is carried out in a new building 70 feet by 315 feet. This company makes it a point of being very particular in the selection of material and the manufacture of its goods, so as to secure durability and the satisfaction of customers. Besides its immense volume of smooth wire fencing, it manufactures a complete line of fencing and readers wanting a neat, durable, yard, lawn or cemetery fence, with or without steel gates, steel posts and rail, should write the company for their catalogue and it will be mailed free.

Every year improves the demand for bulbs and early spring flowering plants. Nothing can be more beautiful nor indeed offer greater attractions in the cold and chilly spring months than the gorgeous displays of flowers which the flowering bulbs afford us. They fill a gap between the melting snow and warmer time to follow, and give our parks and cemeteries an air of cheerfulness when all else is dreary. It would surprise most people to know how great the trade of importing bulbs, chiefly from Holland, has become. One of the well known importers and grower's agents is C. H. Joosten, 193 Greenwich street, New York, who imports large quantities of bulbs and other plants suitable for parks and cemeteries. He will gladly make estimates for complete assortments, and give reliable information to correspondents.



# PARK AND CEMETERY.

FORMERLY THE MODERN CEMETERY.

A Monthly Journal Devoted to Parks and Cemeteries.

R. J. HAIGHT, Publisher,  
334 Dearborn Street, CHICAGO.

Subscription \$1.00 a Year in Advance. Foreign Subscription \$1.50.

VOL. VI. CHICAGO, OCTOBER, 1896. NO. 8

## CONTENTS.

EDITORIAL.....	341
THE HARMONY OF ARCHITECTURE AND LANDSCAPE WORK.....	342
*THE BOOTH MEMORIAL, WOODLAWN CEMETERY, NEW YORK.....	343
THE CEMETERY AS A WORK OF ART.....	344
*SOME MONUMENTS IN LINCOLN PARK, CHICAGO .....	346
CONVENTION ECHOES.—*RECEIVING VAULT, PROS- PECT HILL CEMETERY, OMAHA, NEB, .....	348
STORY OF THE GARDEN.....	349
*GARDEN PLANTS, THEIR GEOGRAPHY, XII .....	350
GOLDENRODS AND ASTERS.....	351
*SOME PECULIAR MONUMENTS.—NOTES.....	352
LANDSCAPE GARDENING IN CHINA.—LIBELLOUS IN- SCRIPTIONS ON MONUMENTS—TREES.....	353
*THE KANTZ VAULT, METAIRIE CEMETERY, NEW OR- LEANS.....	354
PARK NOTES.....	355
CEMETERY NOTES.....	356
RULES AND REGULATIONS.—LEGAL.—*SPIRÆA TO- MENTOSA ALBA.....	357
PUBLISHERS' DEPARTMENT.....	358

\* Illustrated.

ORGANIZED effort to improve our cemeteries, the results of which have been fairly remarkable of late years, is well represented in the larger way by the Association of American Cemetery Superintendents, whose recent successful convention at St. Louis has been fully recorded in these columns. To reap the full benefit of such association has been a matter of careful consideration on the part of those interested in the work of improvement; for it could not be expected that the influence of the national body would be far reaching enough to confer practical benefits on all the cemeteries of the country and for obvious reasons. But Nebraska leads the way in offering a solution of the question by organizing the Nebraska State Cemetery Association, for the purpose of disseminating a knowledge of cemetery management in that State. Nebraska is the first state to take such a step, and it would appear, that as the State association will include all cemetery officials in its membership, the influence of the

national body would meet a responsive chord in the state body to extend the good work of improvement to the smaller cemeteries and burial grounds, by creating a spirit of progress among officials of every degree. Attention has already been called to the Onondaga, N. Y., county association, which was organized for a similar purpose.

“THE supreme point of our enjoyment of lawn planting is reached when we have compassed in our grounds the loveliest effects of color,” says Samuel Parsons, Jr., in his interesting work on *Landscape Gardening*, to which we venture to add that these lovely effects are to be seen at their very best in the autumnal season through which we are now passing. A brief visit to Graceland cemetery, Chicago, recently, revealed many beautiful effects in coloring as a result of studied planting in that in many respects ideal cemetery. No pen picture could do the varied effects justice, and until the art of accurately reproducing the colors of nature on the letter press is perfected can the pleasing picture of the fall season be more than a memory. The many tints of the foliage are ever changing, and the bursting seed pods of the berry bearing shrubs bring to light new beauties that must be seen to be appreciated. Park and cemetery planting for fall effects has not received the attention that it deserves. But the reason is not hard to find. There must be intelligent appreciation of nature's laws; and the better knowledge possessed of the resources she offers for the effects proposed, the finer the effects produced. Landscape work is fast receiving its due recognition as art. And it is art of a high order too, requiring not only profound study to attain knowledge of the material so lavishly offered by nature, but that artistic sense which can create harmonious effects, both in the design of a landscape, the distribution of the plant life used in its composition, and for color effects, the choice of the material at hand to produce not only the desired effects but the best effects possible. So far as autumn is concerned the landscape artist has a broad field to cover. The variations of tone and color under the influences of sun and shadow which the season so freely alternates affects the problem also;



but the stimulating influence of a love of nature, makes the pursuit of knowledge a delight, resulting sooner or later in an ability to work in harmony with her laws and help her to reproduce her effects on the design arranged by human intelligence.

#### **The Harmony of Architecture and Landscape Work.**

Under this head Mr. Downing Vaux, in *The Engineering Magazine*, presents an interesting discussion on the advisability, or necessity, of considering the surroundings of our public and private buildings in the beginning of the work, and the beneficial results of cooperation between the landscape architect, the architect or the engineer as the case may be. He quotes the World's Fair as an example of this cooperation and the influence it has already exerted and will continue to exert. The following extracts will be of interest:

"Much of the work, in our larger cities particularly, is admirable in every respect, and we are generally learning to demand that our dwellings and our public constructions shall be given an appropriate setting; but it is frequently found, when it is proposed thus to bring the setting into harmony with the main work, that radical changes in some important feature, which could have been easily made in the beginning, are now impossible except at great expense, and the artistic effect of the work suffers accordingly.

"The work of the landscape architect would be of far more value generally, if he were consulted in the beginning, as at the Chicago Fair, and given an opportunity to suggest changes in the location of buildings, instead of, as in many cases, called in as a kind of after-thought and compelled to make the most of an unfortunate position.

"By securing his assistance at the outset, the building would get the immediate benefit of such local features as the site afforded; the trees and rocks would be saved, to serve as a basis for the more extended treatment decided upon, instead of being sacrificed to the profit or convenience of the contractor; the materials removed in the construction of the work could be at once disposed in accordance with the general scheme for the treatment of the grounds, and the building and its setting grow simultaneously toward orderly completion.

"The architect should be willing to meet the landscape architect in the consideration of various points where the work of one merges into that of the other. Each is dependent on the other for the full completion of the picture he has in mind, and both are injured if this ideal, through lack of cooperation, is not reached.

"Where the situation is on uneven ground, the design may be relieved by a broken sky-line and

entrances on the different sides at varying levels. Where the site is comparatively level, the structure gains by the subordination of all minor features to the main motive, and the concentration of thought on that. So, in the work of adding to the effectiveness of buildings and making their surroundings more interesting, success is often attained by the bold adoption of a formal treatment, where the most can be made of lines of stately trees, well-trimmed hedges, and strait, flower-bordered walks, leading to an elaborate gate or arch. This treatment becomes especially happy when judiciously incorporated in the design for a public park, and gives an opportunity for the architect and sculptor to add to the natural beauty.

"The beautiful examples so placed gain greatly in the total elimination of all surroundings that would otherwise possibly dwarf their height or interfere with light, delicate features which are brought out in strong relief by a background of foliage or a delicately-verdured hill slope. The thoughts of the passing wanderer are led to dwell on the life work of the subject of the sculptor's chisel, and incline him to linger and admire when the surroundings suggest rest and contemplation.

"The public parks of our large cities have been generally laid out and taken care of by men of intelligence and thought, and the results are most creditable. The dweller in large cities can walk along shady paths, under rustic bridges, by cool lakes, without leaving the city limits; he can ride and drive on splendid roads, enjoy the great variety of flowers and foliage growing there, and feel the harmonious blending of natural and architectural features. Just here is where the architect can help in linking land and water together in the general design. The shelter can be placed among the trees along the path, and be of an informal design that will not clash with the park idea; it can be of cool tints with little elaborate ornamentation.

"The outlook or tower on the highest ground can have a slender tapering sky line that will even accent the limits, instead of dwarfing the extent of the park grounds. Not only should the bridge be a picturesque structure itself, but the abutments should be made to fit the ground, and not end in mere masonry necessities.

"The addition of some of the bright flowering aquatic plants to the pool or fountain combines the daily variations of living examples of the most beautiful and exquisite flowers with the cool, clear effect of running water.

"Where music is heard across the water, a blending softness is given to the notes that is distinctly caused by the undulating surface, and this can be taken advantage of by placing the music stand on



an island. Aquatic birds add life to the water, and are seen to advantage from boats, which are more used as their benefits are appreciated.

"Comparatively few people know that the work of the landscape architect is carried out in a thoroughly business-like way, and on the same general lines as architectural and engineering designs.

"A topographical survey of the ground is first made, and from that a plan is drawn, showing the location of the proposed drives and walks, with the buildings. The changes in the surface are shown by figures. Next a planting map is prepared, indicating the position of all trees and shrubs to be planted, and giving a list of their names. The detail drawings for special features, such as arbors, summer houses, etc., follow.

"Great advance has been made in the cultivation of shrubs for ornamental planting; the number of hardy varieties is steadily increasing, and the interest taken in them is growing. Large masses of the same variety are now used to heighten the effect at certain points; the choice specimen is given prominence, more room is allowed for free growth, the pruning is done with more care, and the whole effect is one of great richness in materials and growth.

"Plantations of shrubs are used to bring buildings into closer relation to the surroundings, they help to connect the lawn with the larger growing trees and rocks; on the margin of pool, lake, or stream they are especially beautiful, as the effect is often doubled by the reflection in the water.

"Trees, both for shade and to add beauty to the landscape, are of the greatest importance. They represent years of growth, and live even in our city streets; they are the crown on the hill, the companion of road walk, and building, and the clothing of the hillside and hollow. They are of great variety, the pines and hemlocks, with their deep green needles, affording a noble contrast to the light green leaves of the birch and poplar.

"Brooks, waterfalls, ponds, lakes, rivers, and the shore of the sea, appeal to man in their different ways of adding beauty to the scene he looks at; and, when nature has failed in supplying the first four of these, he can often add the lacking elements.

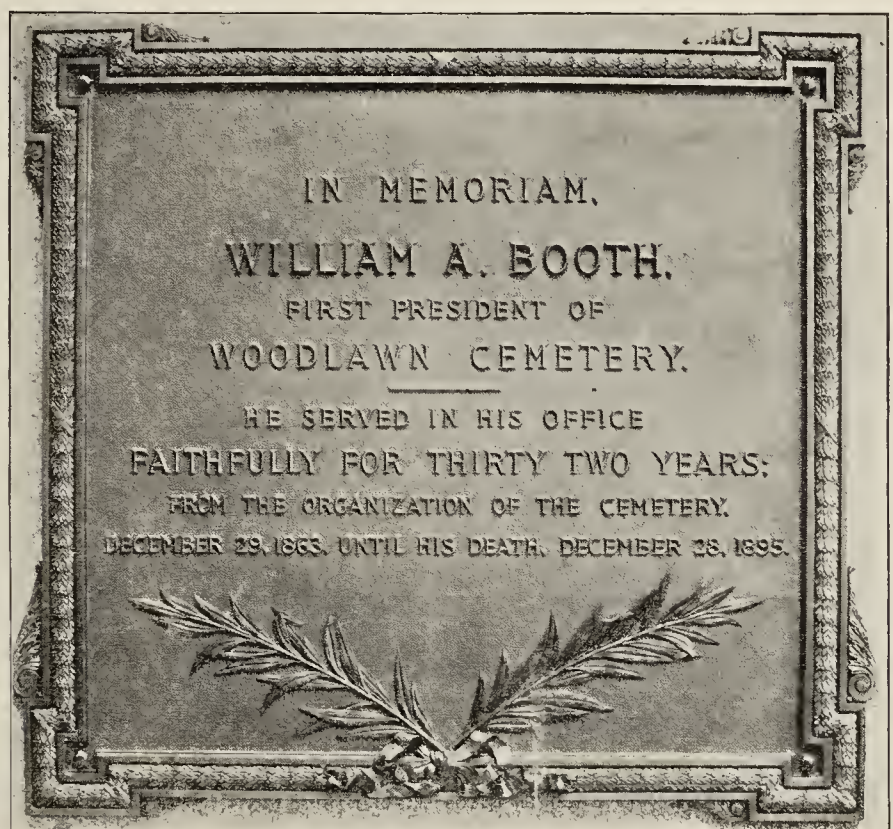
"Let us hope that the demand for parks, gardens, and the preservation of natural features of beauty will grow, and that the supplying of these wants

will be entrusted to men especially interested in the thoroughly artistic development of all the various opportunities in a business-like and sensible way; thus the best results will be obtained from the expenditure, and stupid mistakes will be avoided."

**The Booth Memorial, Woodlawn Cemetery,  
New York.**

Woodlawn Cemetery, of New York, has recently placed on the wall of the principal room in its office building at the entrance of the cemetery grounds a handsome Memorial Tablet in bronze to William A. Booth, late president of the cemetery corporation, executed by the Gorham Manufacturing Company, and illustrated herewith. William A. Booth became president of Woodlawn Cemetery, New York, upon its organization December 29th 1863, and continued in that office until his death which occurred after he had reached the ripe age of 90 years, on December 28th 1895, almost exactly 32 years.

He was always deeply devoted to the interests of the cemetery, he rendered valuable service at its organization and during the years of its advancement, retaining to the last, notwithstanding his advanced years, the same keen interests in the details of its management that had characterized his labors for the Cemetery in its earlier history and to him more than to any other man is due the remarkable success of the enterprise, and care with which all the details of its management and grounds have been maintained.





### The Cemetery as a Work of Art.\*

An American poet once said that he wished his body to be cremated and his ashes scattered from a lofty height of the Sierras so that the wind might carry his dust into the crannies of the mountains and become a part of their substance.

Those everlasting hills were the monument he craved, to be absorbed by them the honor he desired.

Probably but few paid any attention to his words, and perhaps they attributed them to the idiosyncrasy of a disordered mind. But, was it not a poetic, unselfish and legitimate ambition?

Great and sane men crave the distinction of burial within the walls of Westminster. To be buried there is the highest honor England has to offer her illustrious dead; and though the record of such interment is but a brief inscription graven on a stone in the floor, the assurance of such recognition would be sweet balm to the departing spirit of many a celebrated Englishman. Now, if it is good to be buried in a building grand in itself, grand in the historic memories that cluster around it, and grand in the famous names recorded above the impalpable powder of past generations, why is it not *better* to be absorbed by a sublime mountain?

The building, it is true, is a living work of art in that it breathes the spirit of the artist who designed it, but it is subject to deterioration by the action of the elements and is only kept intact by the constant care of man. At best its span of existence is short.

But a mountain is a living thing, a part of old Mother Earth. It is subject to the yearly cycle of changing seasons, its summit ever kisses the skies, while around it storm clouds roll or mists are folded, or its snowy peak stands clear cut against blue ether.

It is more than mere earth, mineral and stone. I hold that there is greater opportunity for the untrammelled dust scattered broadcast on the Pacific Slope than for that packed selfishly away in the crypt of a mighty building. There is a chance for it to be used repeatedly as all of nature's materials are intended to be, so that, having been transmuted into a noble Redwood or a sturdy Pine, the dross may be so nearly eliminated that a final appearance, perhaps as a delicate Edelweiss on the brink of a glacier, will fit the purified atom for translation to some fairer sphere whose coarsest dust corresponds to the most refined that this world knows. But, if any object to being sown broadcast, (and probably some *will*), why not try and rouse in them the ambition to be buried in a work of Art more perfect than Westminster Abbey and as beautiful as the Sierras?

Are there not in this day indications of a faint stirring in the hearts of men of the feeling that it is better to be laid to rest in a peaceful place such as living men long for when weary, rather than in an artificial desert of stones. The tired body and brain turns instinctively for rest and refreshment to the simple beauty of natural landscape. Grandeur and sublimity are in themselves overpowering and for that reason lack the solace and restfulness of woods, lakes, and streams. The quiet, shaded glen; "the violet by the mossy stone"; the singing brook or rippling lakelet; the soft twitter of wild birds; the drowsy hum of insects; *all* phases of sylvan simplicity appeal to the ebbing vital force of man.

Is not this a token, may it not be a silent guide, especially an encouragement to the members of the Association I have the honor to address, to continue their efforts to raise the standard of public opinion as to what constitutes fitting homes for the dead? Let us think so, and let them continue to strive to make noble works of art, artfully artificial places of peaceful rest, quiet

\*Paper read at the St. Louis Convention of the Association of American Cemetery Superintendents, September, 1896. By Mrs. Fanny Copley Seavey.

resorts for weary wanderers, pleasant last homes for the dust of humanity, so that the living need no longer banish their dead to the conventional, lugubrious stone yards that they themselves enter with regret and leave with relief. And let them be made along the line indicated by the natural instincts of mankind so that each shall be a perfect landscape of its kind whether pastoral or picturesque as fits the spirit of the natural landscape it replaces or becomes a part of. Humboldt calls landscape gardening "composing landscapes," which clearly shows the close relationship between this art and that of landscape painting. And it is true that the fundamental rules of the two *are* identical, and the chief of these is unity.

It is said of the master landscape painter, Corot, that what he wanted to express in painting was "not nature's statistics, but their sum total; not her minutiae, but the results she had wrought with them; not the elements with which she had built up, (note the expression), had built up a landscape, but the *landscape itself*"—that is a certain broad effect—and that he "created landscapes out of the elements which in nature's presence he had stored in his sketch book and in his memory. He but completed the beautiful messages she had been suggesting here and half revealing there."

The landscape gardener also composes and builds up landscapes and the artists among them do so from nature's own suggestions by carefully working out and combining hints that they have noted in woodland rambles, from fleeting glimpses of natural beauty gained from the window of a railway train, from careful study of masses of foliage, from analytical examination of shadow effects, from *all* the data that his artistic eye has gleaned and that he has stored in his note book and his memory, reinforced in this day by photography.

True, *he* must be hand in glove with the elements that compose his picture for they correspond to the painters pigments, they are his medium of expression, and it goes without saying that he must have perfect control of them before he can express anything; just as we must have a vocabulary before we can make our ideas understood. But, on the other hand, he must have something in mind that he intends to express, a beautiful effect in nature that he wishes to set before the world, or his materials are useless; just as one may know lots of words, but having no idea to present, they avail nothing.

So, the landscape gardener strives to express some one of nature's phases, and to secure it he knows how to subordinate detail to the broad general effect. He never loses sight of the basic truth that the *whole* is greater than any of its parts. In a word he studies analytically, but he treats his work synthetically.

To apply these rules to cemetery work ought not to be difficult.

First, as Downing said, "let not the individual consider only what he wishes to do in his folly, but study the larger part that nature has done in her wisdom, viz: do not strive to *unmake* the character she has stamped on a piece of ground." This may be taken to apply more especially to the surface of the ground. Then, as to planting he further emphasizes the same truth by saying explicitly "that true art in landscape gardening selects from the natural materials abounding in any location its best sylvan features, and by giving them a better opportunity than they could otherwise obtain brings about a higher beauty of development and a more perfect expression than nature herself offers." But the sort of man we have in mind does not forget, as Prof. Goldwin Smith once accused some one of doing, that he is only the Editor and not the Author of Nature.

But the matter is, unfortunately, less simple than it seems because Cemetery esthetics are seriously handicapped by time honored customs old enough and bad enough to be set aside as obsolete; by preconceived notions; and by man's vanity and sel-



fishness expressed in a material burden of stones that leave the artist very nearly helpless.

General education as to what constitutes a fit burial place is the principal hope for relief from these unfortunate conditions. Like all artificial landscapes, a cemetery needs to be treated as a whole. But it is almost invariably considered as an aggregation of lots and divided up with the precision and almost the decision of a checker board.

Lot owners must be brought to look at the matter in a larger way than is customary before any marked improvement will be seen, for with them, as has been said, largely lies the relief sought. They must come to understand that each lot unostentatiously takes its place in the making of the broad picture; and that each is individually good only as it fills its place in that picture.

All who feel an interest in the subject can do something towards diffusing the dawning light of the 20th century idea of what are fitting burial places and memorials for the dead and thus help to invest it with a more wholesome environment. And perhaps there is no better method than by endeavoring to establish the sentiment that it is better to own a share in a Landscape than a lot in a Cemetery.

In the minds of many, perhaps of most, people a lot means an angular block. Being thought of as a square it comes to be treated likewise, and, unless some restraint interferes, its angularity is emphasized by definite boundary lines with the reduplicated rectangularity we are all familiar with.

How much better to own a share in a Landscape unencumbered by conventional stones and undefaced by gaudy carpet beds, neither of which have place in any known variety of natural landscape; a share in a place so charming that a Corot, an Inness or a Tryon would wish to paint it.

Doubtless ownership in Landscapes as famous as paintings by celebrated artists would soon develop the feeling that an artistic landscape that is to be perpetually cared for as a work of art is in *itself* the most fitting memorial for all who sleep therein; that noble, living, growing trees are appropriate monuments to immortal souls that have passed to a higher life where they, too, are still growing; and it seems reasonable to suppose that the right of interment in such Landscapes would come to have a value at least comparable to sepulture in Westminster.

For the present it is fortunate for all that wealth insures many large lots in cemeteries thus securing a proportion of comparatively open space. In modern cemeteries these expanses are increased, in locations where good landscape composition demands them, by reserving sections where plots are sold only to those who do not care for either monuments or stones; and still farther by preserving such natural bits of beauty included in the site as are unsuited for interments, as, for instance, sharp inclines that when well wooded or planted to shrubbery add an hundred fold to the charm of the grounds.

All of these features are a distinct advantage to every share holder for they make possible effects not otherwise obtainable until higher standards prevail.

But in the cemetery of the future the lots of the wealthy will be indistinguishable from the single grave section. Death will there in *reality* make all equal as it is now *said* to do. There will as it were, be no line of demarcation between the residence quarter and the tenement district. No, it will be a *city* of the dead in name but not in appearance—all will then sleep in a bit of the blessed country.

For the cemeteries of the future will be, as I have tried to outline, works of art; consistent, harmonious landscapes each complete and perfect of its kind; there will be no visible divisions for lots will melt into each other, plantations of shrubs being placed where the unity of the scheme demands, spreading over parts of many lots, and even over the graves themselves

for they will be level with the surrounding surface; there will be splendid trees, for they are part of a landscape and are fitting as memorials, but they will stand only where the composition of the picture demands trees; many lots will have neither shrubs nor trees, for they will be part of the open expanses that are the basis of good landscape art and are as essential to it as what we call the sky, is, in its relation to the starry worlds around us; not every lot will have a monument, but such works of sculptural art as "French's Death and the Sculptor" and kindred dreams of beauty will readily be given a suitable setting because they will never be too numerous and are in harmony with the atmosphere of these Landscape homes of the dead: records will be kept and limits will be invisibly marked, but in these fair pictures there will be no headstones, because the people will have realized—at *last*—that money is better spent in perpetuating lovely landscape memorials than in setting up unsightly blocks of stone—just because some one has them for sale. There may be inconspicuous markers but nothing more. In short, a drive through one of these coming Park grounds will be like the one spoken of in Miss Alcotts "Little Women" where the visitors felt they were passing through a "long gallery filled with lovely landscapes."

And the occupation of the stone mason will not be gone. If nothing else offers we can make Japanese Gardens the fashion and set them to chipping out stone lanterns—a lighter branch of their work than carving stones to hold humanity to earth, most of whom find their weight of sin more than enough.

The gentlemen of this Association are striving to diffuse the light of these new ideas: they are eager to transform the grim stone yards of the present into the fair landscapes of the future; they ask nothing better than an opportunity to build up such lovely earthly landscapes that they will be esteemed worthy, (when they are themselves translated) each to have a star of his own to plan and plant—as Frederika Bremer felt sure Downing was to have. And shall not we, the lookers on, each of whom has a personal interest in the matter *whether we will or not*, do what we can to aid in discouraging the morbid mortuary customs of our time?

I think the majority will answer yes, for, when we come to think about it, the most of us will feel that:

Better the wind swept height of lofty mountain range,  
Bright sun, sweet air, the moonbeam's wondrous light,  
Or starry cells 'neath opal seas that change,  
Than somber stones that press to endless night,  
Better the grassy glade blessed by the sun and dew,  
Where the long shadows lightly come and go,  
Where leafy dome and spire uplift the thought,  
And soaring bird, aloof from all below,  
Carries it on, until a vision's caught  
Of those Celestial Landscapes of the blest,  
Where souls immortal find eternal rest.

A correspondent of *The Garden*, London, asks the editor to give him the names of three of the most beautiful, hardy, deciduous flowering shrubs. In the course of his letter he also describes a specimen of *Spiræa ariæfolia*, which had been planted 20 years. It is 14 feet 8 inches high and the circumference of its branches exceeds 50 feet. The writer endorses the view that such shrubs should be planted in the open and not choked up in borders and groups. A feature of this *Spiræa* is that certain of its leaves turn crimson in the summer. The editor in reply to the question of the best three shrubs gives: *Pyrus Japonica*, *Pyrus malus floribunda* and *Prunus triloba*.





Some Monuments in Lincoln Park, Chicago.

- 1—ABRAHAM LINCOLN.      2—SHAKESPEARE.      3—A SIGNAL OF PEACE.      4—GENERAL GRANT.      5—SCHILLER  
 6—OTTAWA INDIAN GROUP—"THE ALARM."      7—DE LA SALLE.      8—LINNE.  
 ALL THESE IN LINCOLN PARK.



**Some Monuments in Lincoln Park, Chicago.**

Lincoln Park, Chicago, is quite well furnished with statuary, as will be observed from the accompanying plate, although that does not include all the monuments to be found within her limits, and indeed the park commissioners desire to divert further benefactions into other forms of memorial. Although many of the monuments are worthy objects of art, a few excellent, an artistic sense will soon discover that no art commission or other competent authorities were in advisory control of the monumental art features of this beautiful park. But the monuments are diverse in character and association, and in many cases are the gifts of the several nationalities of Chicago's American citizens.

One of the finest works is the bronze statue of Abraham Lincoln, by Augustus St. Gaudens. It represents the martyred president as just rising from a chair which is behind him. The statue and pedestal stands on an elliptical granite platform 60 feet by 30 feet, reached by a flight of steps, and surrounded by a granite bench and balustrade. The memorial was the gift by will of Eli Bates, and was unveiled in 1891. It cost about \$40,000.

Another good work is the bronze Shakespeare, by William Ordway Partridge, the funds for which were also left by will of the late Samuel Johnston. It was unveiled in 1894. The portrait was modeled from the death mask and authentic portraits of the great poet.

The "Signal of Peace," the bronze Indian group by C. E. Dallin, and which attracted considerable attention at the World's Fair, was presented to the park by Judge Lambert Tree.

The most imposing monument, by having prominent architectural features in connection with it, is that of the heroic bronze equestrian statue of General Grant, modeled by Louis T. Rebisso. It was unveiled in the presence of an immense popular outpouring Oct. 7, 1891. It was erected by popular subscription and cost over \$65,000. The statue is 18 $\frac{1}{4}$  feet from the plinth to the crown of the hat, and it stands on a granite arch construction designed by F. M. Whitehouse, architect.

The statue of Schiller was presented to the park by the German-American citizens. It is a replica of the Wurtemberg monument by Ernst Rauss.

"The Alarm," a bronze group of Ottawa Indians, was presented to the park, as a memorial of friendship for the tribe, by Martin Ryerson in 1884. Around the pedestal are four bas-reliefs, illustrating Indian life. It was modelled by John J. Boyle.

Another gift of Judge Lambert Tree is the statue of Robert Cavalier de La Salle, executed by

the Belgian sculptor De La Laing. It was unveiled in 1889.

The statue of Linne, or Linnæus, was erected by the Swedish-Americans of Chicago, and is a replica of the work of Dyverman, a Swedish sculptor. The figure is fifteen feet high, and was cast in bronze at Stockholm. It is mounted on a granite pedestal, the corners of which are embellished with figures typical of the seasons. It was unveiled in 1891.

There are other monuments in Lincoln Park of more or less interest and importance, among them the statue of Benjamin Franklin, the gift of Joseph Medill, and that of Hans Christian Andersen, donated by Danish citizens and unveiled last month.

It will be noted from the foregoing that this park has been highly favored in the matter of monuments. The other parks of the Chicago system have been comparatively neglected in this respect, but the compensation will rest in the possibility of greater works of art being located within their borders. Undoubtedly in the future, more care will be exercised both in the choice of monumental art and its appropriateness for certain locations. Already in some proposed memorials for which bequests have been devised, expert artists and art critics have been invited to advise on the important considerations involved, and we may confidently expect that the future monuments of Chicago and its parks will be works of art, indeed.

---

In a government report from Columbia says *Chambers' Journal*, there appears the description of a tree, known as the chaparro, which possesses the property of being fireproof. It grows on the plains of Columbia and the north of South America called savannas, extensive districts which are parched with heat except during the rainy season. It has long been the custom to clear the ground for the new vegetation which springs up so luxuriantly on these plains after the rainy season by means of fire; and such fires, miles in extent, kindled by the herdsmen, destroy everything in the shape of vegetation except the chaparro tree, which survives to afford a welcome shade in an almost treeless region. It is a small tree, seldom growing to more than twenty feet in height, with a girth of about three feet, and it owes its protection from fire to the nature of its hard, thick bark. The bark lies on the trunk in loose layers, which do not readily conduct heat to the more delicate parts of the structure. It is a general idea among the natives that this tree grows only where gold is abundant in the soil below. That it is common in auriferous districts is indisputable, but there is no ground for supposing that it does not grow elsewhere.



### Convention Echoes.

The paper read by Mr. B. D. Judson, Superintendent of St. Agnes Cemetery, Albany, N. Y., before the Tenth Annual Convention of the Association of American Cemetery Superintendents, held at St. Louis in September on "A Plea for the Perpetual Care of Cemeteries and their Individual Lots," was printed in full in the Albany *Argus*. This paper while dealing with the question on lines often referred to in these columns, presented much information on this subject that will be valuable to disseminate among lot owners.

\* \* \*

Mr. J. Y. Craig, Superintendent Forest Lawn Cemetery, Omaha, Neb., introduced to the convention the subject of the proposed Trans-Mississippi International Exposition to be held at Omaha in 1898. He was authorized by the Mayor of Omaha to invite the Association to hold their annual convention in Omaha in that year. While the Convention did not deem it necessary to place itself on record on the matter at this meeting, there was quite a sentiment in favor of the proposition. The object of the Exhibition is to exhibit particularly the products, resources, industries and civilization of the states and territories lying west of the Mississippi river.

\* \* \*

Mr. Sid J. Hare, Supt. of Forest Hill Cemetery Kansas City, has devised a scheme for recording the particulars of his plants and trees, which becomes a mine of information at any time on the plant life noted. The method takes the form of a blank book with pages ruled on both sides into main divisions, these again subdivided, so that the minutest detail can be entered. For instance the page is about 12 in. by 9 in. which on one side has the following main columns with subdivisions (in parentheses): Number; Name (scientific-common); Orders, with subdivisions for several years; Sub-Kingdom, (tree-shrub-plant-vine); Flower, (form-color-size-month of bloom-fragrant); Leaf, (form-size-color in spring-color in fall-month leaf opens-month leaf falls); Plant, (form-height-spread-hardy-tender); Top, (annual-perennial); Stems, (color-upright-oblique-horizontal-weeping). The above is continued on the other side of page as follows: Number; Bark, (scaly-rough-smooth-color); Root, (fiber-branching-tap-suckers, yes, no); Growth, (very rapid-rapid-slow-very slow); Transplanting, (young, 1, 2, 3, 4 years-fall-spring-hard-easy); Valued for, (flower-foliage-fruit-nut, cone or seed); Prune, (spring-summer-fall-winter-after blooming-before blooming); Soil, (black loam-sandy-clay rocky); Location, (open-protected-sunny-shady-

low-high-dry-moist-in water); Use, (single-group of same-group with others-border or hedge-vase carpet bed); Propagate by, (seed-division-layers-cuttings-grafting-budding); Other notes. At the foot of each page space is reserved for more notes.

We have received a number of prints of snap shots taken by Mr. Hare during the convention; we regret that they are not such as would make good reproductions for publication.

\* \* \*

Many superintendents were detained at their respective cemeteries on account of improvements which required their personal attention; among them, Mr. Bellett Lawson, Woodlawn cemetery, Winona, Minn., Mr. B. D. Judson, St. Agnes cemetery, Albany, N. Y., and for two others the following will explain:

A handsome lodge is in course of construction for Mr. J. C. Dix, Supt. of Riverside cemetery, Cleveland, Ohio. It is from a design of Mr. Chas. W. Hopkinson, architect of that city, and is a combination of Romanesque and Gothic. It is built of Massachusetts red sandstone, with cement porch, floors and paneled porch ceilings. The roof is of Spanish tile with heavy copper flashings. The building will also contain the offices. The reception room is 16 ft. by 22 ft. by 16 ft. high, lined with natural brick of a warm yellow tone. The ceiling is in effect after the Tudor style and the floor, mosaic. The general office of the superintendent is 18 ft. by 25 feet, plastered in hard mortar, tinted. There is a ladies' room with toilet facilities and fire-proof vault. A large director's room and committee room are situated on second floor. Steel beams and terra cotta enters largely into the construction to ensure permanency and resistance to fire. Cost, about \$18,000.

\* \* \*

Mr. T. Donlan, superintendent of Oakdale cemetery, Wilmington, N. C., was busy on the work of constructing a Lodge to take the place of that destroyed by fire in February last. The corner-stone was laid September 19, last, and among a number of pamphlets, records and other matters deposited therein, was a copy of the proceedings of the ninth annual convention of cemetery superintendents. It will be built of North Carolina granite and brown stone. It will be a handsome building. H. A. Tucker & Bro., contractors.

### Receiving Vault, Prospect Hill Cemetery, Omaha, Neb.

Among the improvements carried out at Prospect Hill Cemetery, Omaha, Neb., the present year, is the Receiving Vault illustrated herewith. It is prominently located on the main avenue near



the centre of the cemetery, and is constructed of iron and fire-proof tiling, in dimensions twenty by thirty feet. In design it is of the Grecian order and has a capacity of fifty bodies. Three stained glass memorial windows, protected by iron gratings on the outside, are a feature of the inside decoration and are placed over the beautiful altar at the opposite end of the corridor from the main entrance. The ventilation is effected by six large ventilators about the base and five in the roof.

The Receiving Vault may also be used as a chapel for the holding of funeral services by the lot owners, provided such service does not interfere with the purpose for which it was intended. This structure is the property of the permanent fund of the Association, and all revenue from it will be added to the principal of that fund.

Prospect Hill Cemetery is the oldest cemetery of Omaha, and is situated about two miles from its business centre on a commanding elevation overlooking the city. It dates from 1858. Many of the early pioneers, those who laid the foundation of Omaha's growth and prosperity, sleep their last sleep here. It is not however laid out or governed on the modern ideas of cemetery management, owing to its early establishment and other conditions; but the Trustees are in full sympathy with such ideas and as far as practicable in their judgment apply the modern methods to the practical working of Prospect Hill Cemetery.

#### Story of the Garden.

The story is an old one. Bacon reminds us that "God Almighty first planted a garden"; and, if it was the duty of our first parents "to dress that garden and to keep it," so, assuredly, has the love of gardening, of flowers and of herbs occupied a place in the hearts of men, as in their minds, from the beginning of the world. No class has escaped, and the spell has fallen at one time and another upon the kings and prophets, philosophers and poets, upon men of every calling, creed and occupation, while the sympathies of men of science and learning have been frequently enlisted side by side with those of laborers and artisans. To go back to the bible story is to find this love of the garden in Deuteronomy as in Genesis, in the writings of Solomon as in the words of Isaiah: it makes itself evident in the words of Euripides, of Aristotle, of



RECEIVING VAULT, PROSPECT HILL CEMETERY, OMAHA, NEB.

Theophrastus, of the Quintilian, and it comes out again and again in the verse of Virgil and in many a glowing passage of Pliny.

In the best days of the Roman empire—and the garden of the Roman villa must have possessed many peculiar charms long before gardening was thought of in these islands—the science of horticulture was already widely practiced: the love of flowers was common to men: and, were we able now to look into the gardens of the villas of those days, we should see terraces and statues and glistening marble fountains, gorgeous yet familiar flowers, and tangled masses of creepers and beautifully kept paths leading out of the bright sun, where lilies grew tall and the palms waved, into the deep shade of the ilex, the laurel and the olive. Pliny's garden may have been of this character, and also Virgil's at Naples, or at his country house at Nola, for he loved to have flowers about him. Horace was a townsman first, but he, too, delighted in his retreats in the valley of Ustica and at Tibur, and Ovid carried the love of the beautiful with him into his exile.

It is the same all through; and, whether we read of the gardens of Alcibiades or of the Hesperides, of those of Maecenas or of the rose gardens of Midas, we hear always of their charms and their fascinations; while, if we require an instance of the spell which the practice of the art of gardening has ever exercised, we shall find one in that familiar story of the smile of pity on the countenance of Diocletian, when he looked up from the cabbages he had planted with his own hand, and remarked that he was no longer to be tempted to resume the purple, now that he had once tasted real happiness.—*Quarterly Review*.



## Garden Plants,—Their Geography. XII.

## 8. OLACALES.

## THE OLAX, ILEX, AND CLIFTONIA ALLIANCE.

There are 6 tribes, 70 genera, and 465 species in this alliance. They are for the most part tropical trees and shrubs and with a few exceptions evergreens. Their fine foliage, and brilliant scarlet, yellow or black berries is their chief attraction in gardens.

*Olax* has 30 species distributed in the tropical parts of Asia, Africa and Australia, and one or two climbers are in gardens.

*Ilex* has 175 species distributed over the world, several are found in the temperate regions, and they have in some instances differentiated into such a large number of varieties, and these are so very ornamental, that in England, Ireland, and other mild parts of Europe they are one of the most highly prized features of the gardens. The *Ilex aquifolia* is one of the few evergreens natives to the British Isles, and the varieties with silver and golden variegation and those with peculiarities in foliage, either on the side of greater or less spinosity, are found in all good nurseries. The commoner kinds make superb hedges. In the southern states from New Jersey to Florida a species exists almost identical in appearance, and it is a strange commentary on the Americans that they have not yet found a way to utilize it. It was not without great persuasion that anyone could be induced to ship holly and mistletoe to New York for Christmas in 1875, but it

has now grown to be quite a trade. There is not yet so far as I know a holly hedge in the U. S., the nurserymen have not found a sure way to grow them. They need cutting back freely, when they grow well enough. I have had them grow planted in November, but they are even more sure in late May. The largest English trees are probably to be found in the New Forest of Hampshire, and there are magnificent examples at Notton Hall, Lincoln-



ILEX AQUIFOLIA.

shire, one of the seats of the Earl De Grey and Ripon, and in many other places.

The English Holly *I. aquifolia* in one or two



ILEX OPACA; (Fœm and Mas.) The American Holly.

From *Gardening*.

varieties exists in fine trees in the Smithsonian grounds at Washington and southwards to the Carolinas. Further north they should be planted close to the north side of buildings, as shown in the illustration of one at Girard College, Philadelphia. (See PARK AND CEMETERY, Dec., 1895, page, 174) *I. a. laurifolia* is reputed most hardy, having stood several winters north of New York. Of other evergreens the native "ink berry," *I. glabra*, is the most reliable north, although *I. cornuta* has been tried with fair promise. *I. opaca*, as previously mentioned, makes a superb evergreen tree from Sandy Hook, N. J., southwards, and is hardy in New England. Prof. Smock of the N. J. Geological Survey informs me that at 5 mile beach, N. J., this species has crept close down to the shore. Berry-bearing plants are kept in stock by the Parsons of Flushing who take pains to graft them, and it is necessary to obtain such stock, as the wild plants may be of the male variety, and of course berries are out of the question with them. There is a pair at Trenton as fine as those in the engraving, the female plant bearing abundantly every year. *I. cassine* and *I. Dahoon* are fine southern species, then there are a number of deciduous shrubby kinds hardy at the north such as *I. montana*, *I. verticillata*, *I. lævigata*, the Japanese Sieboldi, said to be evergreen at home, and some others. There are 17 or 18 forms indigenous to the various parts of the United States. *Othera japonica* is the provisional name of a shrub of this affinity whose seeds had not been seen at the time of publication of the *Genera Plantarum*; it is in cultivation however.





Colletia: Two forms of branch on the same stem.

*Nemopanthes* has 1 species only, a native of this country and hardy well north. It is a handsome shrub.

*Cyrilla* has 2 or 3 species one of which *C. racemosa* is a native of the southern states, the others of South America and the East Indies.

*Cliftonia* has but 1 species, found in the Pine barren swamps of the south. The stems furnished the "Titi" stems for pipes, which were much used by the soldiers during the war.

I have heard it stated that the berries and leaves of hollies are emetic and that certain Southern Indians used them for such purposes. However that may be *I. Paraguayensis* is used as a beverage, and the late Dr. Stenhouse mentioned to me in talking tea, that not only it, but *I. glabra*

and several others contain Theine. Beyond this however and the production of birdlime from the inner bark of the English holly, the uses of the Alliance do not appear to be great, although for inlaying the holly wood is very beautiful.

Trenton, N. J.

James MacPherson.

#### Goldenrods and Asters.

In late autumn when the fields and woods are aglow with color, chiefly from the wild asters and goldenrods, a scene is presented which outrivals that of any other season of the year. It has not been the practice of landscape gardeners of the past to take advantage of the opportunity these plants afford of creating a fine effect on the grounds they have laid out. But it is gratifying to find in those of the present day a disposition to use native plants to a much greater extent than has been the custom heretofore.

In this, the eastern part of Pennsylvania, there are some dozen sorts of goldenrods, and though all are beautiful the following sorts would be sure to please; *Solidago odora*, *lanceolata*, *bicolor*, *gigantea*, *Canadensis*, *altissima*, *nemoralis*, *latifolia* and

*cæsia*. These are named somewhat in the order of their blooming. *Odora* is named because of its nicely scented foliage. *Lanceolata* partakes of the same character to some degree, though less pronounced. *Altissima* and *Canadensis* are two quite tall growing sorts, which, when in full display, attract the attention of everyone. I have seen *altissima* in old fields which it had taken possession of, showing acres of golden yellow flowers in early October. It is a good late one. It is not my purpose to describe the differences in the sorts, but those who might become possessed of them would find there was quite a variety in the habit of growth, color of flower or time of blooming. The species *cæsia* is usually very much admired. It is a slender looking sort, with ebony colored stems, and golden yellow flowers, in clusters, in the axils of the leaves. It is a late bloomer. In a woods belonging to Ivy Hill Cemetery, Philadelphia, which is the boundary of the grounds used for burial purposes, this goldenrod has taken pretty full possession, and when in bloom it is a great attraction to the place. This one and another, called *latifolia*, are nearly the only ones in which the flowers are crowded in the axils as described. The last named sort differs from all the rest in this that it delights in wet places. There are many places in public grounds where these goldenrods could be planted. They soon seed themselves, and also spread from the root, so that an increase of numbers could soon be had, if desired.

Of the wild asters of desirable sorts, to be found here, I would name *nova-angliæ*, *patens*, *preanthoides*, *lævis*, *puniceus*, *cordifolius* and *corymbosus*. These are all in the blue or purplish order, though some of them vary, being almost white. *Nova-angliæ* leads all in the display made, on account of its very large dark purple flowers. It is, certainly, one of the best fall blooming plants we have. There is a rose colored variety in cultivation, which is a beauty. *Corymbosus* is almost white, and with *patens*, blue, flowers early. *Prenanthoides* is late. It is tall growing and of a pretty light blue shade of color. *Puniceus* is a strong grower, and can be found usually along water courses, where its purplish white flowers completely hide the banks of the stream. For display I place it next to *nova-angliæ*. As with the goldenrods, there should be a place found for wild asters on all public grounds. I have already noticed their use in some parks.

If the seeds of these asters be saved and sown as soon as ripe, out of doors, they will vegetate first thing in spring, will grow strongly, and will bloom the same season, as I have proved with both *patens* and *nova-angliæ*.

Joseph Meehan.



## Some Peculiar Monuments.

A visit to the cemeteries of the various cities in which one may sojourn for a time while on a vacation trip, reveal many curios, if one may use the term, in memorial art. If photographed and grouped afterwards, they form a collection affording considerable interest and inducing more or less meditation on the why and the wherefore of their existence.



Mr. J. S. Clark, of Louisville, Ky, is one of the monumental dealers who carries a Kodak with him on his travels, and while journeying west last winter in search of renewed health, he was enabled to take a number of pictures; among them those presented herewith, for which we are indebted to him.

The horse monument is erected in the cemetery at Denver, Colo. The horse a favorite of its owner was modeled from life and is cut from marble, the pedestal being of gray granite.



In the same cemetery is the Miner's Cabin, a tomb about seven and a half feet square at base, cut from a solid piece of limestone. Its realistic effect is plainly suggested by the illustration.



The palms standing sentinel in the third illustration indicates its location as belonging to the

Pacific slope, and makes it a unique picture. There is something very dignified in the palm, notwithstanding its frequently dishevelled appearance, and it carries us back so easily by association with the centuries past and gone, that it stands as a connecting link between the past and present; and even leads us forward too, for it bespeaks permanence and lifts itself up into the glare of the sun, unabashed and unyielding. The palm in a landscape is always attractive, always thought inspiring. This view was taken in a Los Angeles Cemetery, and is a characteristic scene of that semi-tropical locality.

## Notes.

In the United States there are 419 different species of trees, and nineteen of them, when perfectly seasoned, will sink in water.

There are said to be at least 400 different kinds of palm trees under cultivation at the vast botanic garden at Bintenzorg, Java. This is doubtless the most extensive collection of palms at any one garden. Three hundred species have been determined, some hundred more which show characteristic differences, but are not named yet, besides other known varieties.

An exchange says: One of the most wonderful examples of vegetable growth and fecundity is illustrated by the Asiatic pemperion. A single seed planted on the grounds of the Berlin Botanical Society propagated a vine which grew to be as large as a man's body in nine weeks. It grew to a total length of nearly 900 feet and ripened over 800,000 seeds.

In Nice, France, there is a society called "The Friends of Trees." The forests and mountains being almost completely devastated and denuded in the Maritime Alps by the ax of the peasant, a prize is given to land-owners who plant trees on vacant spots, and an annual Alpine fete destines a donation of \$100 to the society or individual who plants the largest number. Here is a suggestion.

In the matter of using woody vines in landscaping, Mr. T. V. Munson, the well-known horticulturist of Denison, Texas, says it appears to him that there is great neglect of abundant, rich, native material, which, if judiciously employed, gives most agreeable effects, not obtainable by any other means. These are quick in growth and easy in management in proper place, and their use should be encouraged. Mr. Munson will write on this subject in these columns in a future issue.

In *The American Florist* under the head of Boston notes, it is stated that Supt. Doogue of public grounds has been experimenting with various compounds to find an exterminator for the army worm, and thinks he has now found the long sought article in hard wood ashes and slacked lime. He combines these in the proportion of two-thirds ashes to one-third lime, the ashes to contain not less than eight per cent. of potash, and sifts it evenly over the surface after the grass has been mowed close, and if possible just before a rain storm, in quantity about four tons to an acre.



**Landscape Gardening in China.**

The Chinese were believed to have possessed great skill in landscape gardening from a very early period, though, if we are to judge from the illustrations on the famous "willow pattern" plates, there is some excuse for doubting the extent of that skill says *Chamber's Journal*. It is true that a very ancient writer, Lieu-Tscheu, has some extremely sensible remarks on the pleasures of a garden, in the course of which he says: "The art of laying out gardens consists therefore in contriving cheerfulness of prospect, luxuriance of growth, shade, retirement and repose, so that the rural aspect may produce an illusion. . . . Symmetry is wearisome and a garden where everything betrays constraint and art becomes tedious is distasteful." But it was the letter rather than the spirit of Lieu-Tscheu's advice that his countrymen followed when they elected to patronize the "natural" and the "picturesque", and they soon reached a stage of cockneyfied imitation of nature which Horace Walpole himself could not have surpassed.

In 1843 the Royal Horticultural Society sent out the eminent Scotch botanist, Robert Fortune, to visit these famous gardens of China—the land to which we owe the peony, the chrysanthemum, the azalea and the camellia. He was enchanted by the magnificent azalea-clad mountains of the Che-Kiang, one blaze of gorgeous bloom from foot to summit, but he saw little of the renowned landscape gardens, though enough to show him that much that was fashionable in English gardening was merely a relapse into Chinese barbarism. Indeed, as a matter of fact, the hideous system of "bedding out," which has in recent years been so popular in this country, is simply plagiarism from the Chinese. Those detestable cockney ribbon gardens, with their bands of red, yellow, and blue—a blaze of gorgeous but incongruous and inharmonious color—are a slavish imitation of Chinese taste—the taste to which we owe such artistic masterpieces as the "willow pattern" and the illuminated tea chest!

**Libellous Inscriptions on Monuments.**

A suit for damages on account of an inscription on a monument before a jury in the Circuit Court, Memphis, Mo., resulted in a verdict of \$1,000 for the plaintiff. In December, 1890, some scholars at a country school in Knox county, Missouri, got into a difficulty which resulted in injury and subsequent death to a boy named Coe. From the mass of evidence the grand jury indicted one of the participants for murder, but he was acquitted on trial. This exasperated the father of the Coe boy, a wealthy farmer, with a family burying ground on his farm, who afterwards erecting a monument to his dead son, had the following inscription cut on it:

"Nathaniel S. Coe, son of E. M. and N. V. Coe, born Aug. 23, 1870; died Dec. 6, 1890. Died from violence of William and Jesse Wright with a club." He did this, as he said, for the purpose of letting the people know what he thought of the matter.

When William Wright became twenty-one years of age he sued Edward M. Coe for libel, charging that the writing on the monument was false, malicious and libellous.

Judge Ben. E. Turner, before whom the case was tried, held that the writing was a libel if false and malicious, and submitted the case to a jury under proper instruction. They found for plaintiff and assessed his damages at one thousand dollars. The case is a novel one and without a precedent that the court or lawyers could find.

A motion for new trial was filed and overruled. The judge, however, thought that in view of all the circumstances that the verdict was excessive in amount, and required plaintiff to remit five hundred dollars of the verdict. This was done and judgment rendered for five hundred dollars which amount Mr. Coe arranged to pay. The objectionable part of the inscription on monument, however, Mr. Coe agrees to remove. If he fails in this he may again be sued for libel, for keeping and maintaining the libellous matter on his premises.

**Trees.**

Set out trees; adorn the homestead;  
Make it pleasant all around;  
Let the elms and oaks and maples  
With the evergreens abound;  
Let the home be so attractive  
That the boy that is today,  
When he shall arrive at manhood  
And in foreign lands may stray,  
Turn with longing heart and loving  
To his home those hills among,  
Thinking how the trees are thriving  
Which he helped to plant when young.

Set out trees along the highway:  
Place them thick on either side;  
In the present joyous springtime,  
Every one his part provide;  
Set out walnuts, chestnuts, beeches  
Where the playful squirrels come,  
In the hemlocks, firs and spruces  
Shall the song birds find a home.  
Let their branches, growing, twining,  
Forming arches o'er the way,  
Shield the horse and screen the rider  
Through the long, hot summer day;  
Thick green leaves the golden sunshine  
Hiding while the dog star reigns,  
Then, when autumn paints them gayly,  
Carpeting the hills and plains.

Set out trees, upon the common,  
Ashes, lindens, poplars, birch;  
Set them out around the schoolhouse:  
Place them thick about the church;  
Have the children's playground shaded,  
And the public walks as well,  
And the joys from these arising  
Coming ages glad will tell.  
These shall live and grow and gladden  
While we molder 'neath their leaves.  
Let us, then, improve the present—  
Leave behind us priceless trees.

—Annie G. Marshall.



**The Kantz Vault, Metairie Cemetery, New Orleans.**

The illustration of the Capt. Joseph Kantz vault below, gives a good general idea of the style of such tombs in New Orleans, where the prevailing conditions of low ground have led to the adoption

the mound is three feet, and in this mound a vault is built of brick and cement to contain the bodies. The material used for the principal construction of this tomb is Georgia marble and the figure is of Italian marble. It was designed and built by A



of certain methods of construction to meet the circumstances. The base of this tomb is eight feet eight inches by twelve feet in area. The height from the base to the roof is eight feet ten inches, and height of statue is five feet six inches, giving a total of seventeen feet four inches. The height of

Weiblen, New Orleans, and is a type of many.

This short description in connection with the cut will explain why in the Metairie Cemetery, New Orleans, the tombs are raised so far above the general level of the land, and that a flight of steps leads to their entrances.



## PARK NOTES

Plans are to be prepared for an esplanade and park about the harbor at Newport, R. I.

\* \* \*

The Lincoln Park, Chicago, commissioners, estimate that \$291,000 will be required to meet the obligations and prosecute the improvements arranged for next year.

\* \* \*

Pueblo, Colo., is rapidly progressing towards a park system. Two park districts are now in progress, one north and one south of the river. Some valuable donations of land have been made to the city for this purpose.

\* \* \*

New Orleans, a city of squares and small parks, is becoming infected with the general activity now being more or less displayed over the country, in the matter of the improvement and care of parks. Many improvements are planned, and considerable effort is being expended to bring the many beauty spots into an attractive condition.

\* \* \*

The gardens of Buckingham Palace, London, are about forty acres in extent, of which space five acres are occupied by a piece of ornamental water. The grounds are skillfully laid out and planted with beautiful trees, and in the Queen's summerhouse are the eight frescoes from "Comus" which were painted by Eastlake, Maclise, Landseer, Dyce, Stanfield, Morris, Leslie, and Ross.

\* \* \*

Essex County, N. J., under its new park law, will have when the Park Commission has completed its projected parks and park ways, about 3,000 acres of park property. The total area of Essex county is 129 72 square miles, or 83,923 acres, including 4,631 acres of tide marsh and 1,646 of water. This 3,000 acres of park will make the county prominent among municipalities having large park systems.

\* \* \*

A gigantic scheme of parkway improvement is talked of for Long Island, N. Y. It is proposed to construct a driveway from Brooklyn to Montauk Point, which will make the distance 100 miles and cost some \$20,000,000. The idea will include bicycle paths and very wide sidewalks. It is believed that country seats of the wealthy classes of Brooklyn and New York, would be established along this magnificent boulevard.

\* \* \*

Among the features to mark the thirtieth anniversary of Wm. Logan Rodman Post 1, G. A. R., New Bedford, Mass., is the planting of a "Liberty Tree" on the common of that town, for which a little earth in which to plant it has been solicited from every state in the union. The idea has met with a hearty response and, in addition to that from the states, a portion has been gathered from the historical battle fields of the Revolutionary war. Provided success attends the effort a vast amount of interest and patriotic sentiment will envelope the growing tree.

\* \* \*

Hartford, Conn., has been having trouble on its hands in the matter of its parks, through the perversity of the directors of the state reformatory. The city has been fortunate in receiving gifts of land for park purposes, to improve which in the highest sense competent authority was consulted. The state reformatory directors, regardless of park interests, bought a site for their buildings, which according to the *Hartford Courant*, and in spite of remonstrance, cuts the park system in two, destroying the

general plan. It raised an indignant protest which should result in reinstating things. Clashing of authorities should never be permitted by the public, whose servants such authorities are.

\* \* \*

The Peoria Park system, for which a board of trustees was organized about two years ago, is rapidly showing the effects of systematic work. The principal parks are Glen Oak Park, the largest; Laura Bradley Park, the gift of Mrs. Lydia Bradley, 134½ acres; Madison Park, 86½ acres; South Park, ten acres. The total expenditures on the system to June 1, 1896, has been \$293,091.79 and the receipts \$319,922.78. Glen Oak Park was recently formally dedicated to the public with much civic ceremony and popular participation.

\* \* \*

Somewhat of an innovation is about to be introduced into Lincoln Park, Chicago. Commissioner Henrici recently purchased some song-birds in England, which are intended as a gift to the park. They will be domiciled in the large greenhouse, and arrangements have been made to accommodate and protect them. It is expected they will serve a double purpose, that of ridding the trees and plants of grubs and insects and add to the charms of the house by their warblings. In variety the gift consists of the Japanese Robin, European Wagtail, Blue Java Sparrow, Gray Java Sparrow, and others.

\* \* \*

An inspection has been made of the various points and islands of the St. Lawrence by the New York State Fish, Game and Forestry Commissioners, in anticipation of purchases for park purposes. For some time past there has been considerable feeling raised due to the private ownership of so many of the St. Lawrence islands, and the constant menace of trespass complaints against unwitting visitors. It is proposed to establish a state or international park to include desirable islands and points of interest to secure to tourists and pleasure seekers for ever, such facilities to enjoy the beauties of the river and its scenery as a state arrangement may secure.

\* \* \*

Over \$600,000 has been expended on the park system of Cambridge, Mass., the past three years, out of an estimated total cost of \$2,000,000, while the completion of the scheme may not be expected for many years yet, certainly not in this century. Cambridge Field, in East Cambridge, one of the main features, is however rapidly approaching completion having received particular attention. It is a recreation ground in every sense of the word, in the centre of which is located a model shelter house, of picturesque design. Permanent sand courts for children are finished and ample provision has been made for all kinds of ball and other games. The planting scheme is also far advanced.

\* \* \*

D. H. Burnham, the well-known executive of the World's Fair, has laid before the prominent citizens of Chicago a comprehensive scheme of park improvement for the lake front, which carried out would place the city in the front rank of urban magnificence as regards park embellishment. On the lake front, now being filled in, the scheme provides an arrangement on the Italian garden style, in which a triumphal arch, public statuary, memorial buildings, fountains, etc., shall be imposing features of the scene. This portion is to be connected with the north and south side park systems,—to the north by a handsomely proportioned subway, artistically designed and decorated, passing under the river,—to the south park system by a parkway including a waterway, dotted with islands, and designed to embody and emphasize magnificent landscape effects, besides giving every facility for land and water recreation. The cost is estimated at \$4,000,000, a comparatively small sum considering the possibilities of the project and its immense benefits in the future.



## CEMETERY NOTES.

Paper coffins are coming into use. When stained and polished they equal in appearance those made of wood, and have the advantage of being much less costly.

\* \* \*

The spot known as Golgotha, in Amesbury, Mass., where the first eighteen settlers of Amesbury were buried, has been turned over to the Town Improvement Society, by Mr. Frank Morrill, the owner. It is proposed to improve and curb it and erect an appropriate memorial.

\* \* \*

The trustees of Oconee Hill Cemetery, Athens, Ga., have decided to make the office of sexton a yearly elective office. This is a step backwards, for while it might excite an immediate zeal in the work, it tends to destroy permanent interest in the duties involved, a matter of the first importance in cemetery grounds.

\* \*

The Board of Health of Cincinnati, O., has steadily pursued the idea of doing away with the use of the small church grave yards for burial purposes. The refusal to grant a permit some time ago raised the question and the health office took occasion to impress upon churches owning such burial places the fact that they will have to go.

\* \* \*

The trustees of Woodmere Cemetery, Detroit, Mich., have contracted with the Quarter Master General, U. S. A., for 10,000 feet of ground, adjoining the G. A. R. lot, and to remove all the burials at Ft. Wayne, the government post just below Detroit, to Woodmere this fall. All future burials from that post will be made in Woodmere.

\* \* \*

In Mount Vernon, Mo., its enterprising ladies raise funds for the maintenance and improvement of the local cemetery by giving ice cream suppers and such like entertainments. In Crawford County the following notice suggests at least active solicitude for the rural burying ground. "There will be a working at the Lockhart Cemetery, on Dry Creek, on Saturday, Sept. 5. All that are interested are invited to turn out and bring their dinners, as a basket dinner will be served on the ground."

\* \* \*

It is gratifying to note the increasing interest being taken in the improvement of their grounds by the Catholic cemetery associations. Several papers read at the recent convention of the Cemetery Superintendents at St. Louis, were by superintendents of Catholic cemeteries, and among the new active members admitted at that meeting was the Rev. J. J. Heffernan, pastor of the church of the Visitation at Schuylerville, N. Y., who takes marked interest in cemetery improvement.

\* \* \*

At Hendon, a favorite recreation suburb just north of London, is a tavern in a churchyard, with tombstones all about it, which has been kept there for many hundred years and is the only licensed house in such a place. The original building was burned down 200 years ago, the present house having been built soon after the restoration of Charles II. It is believed that it was once a church house, as by the terms of the lease a room must be set aside for parish meetings and for the preservation of the parish records.

"Annendale," the former country seat of the Harrison family, near Baltimore, Md., a tract comprising some 200 acres has been purchased for a cemetery. It is situated about ten miles from the City Hall on the line of the Pikesville railroad. It will be called "Druid Ridge" and will be laid out on the modern plan of landscape work, patterned somewhat after Woodlawn, New York City. Drawings for a receiving vault to cost \$50,000, and with receptacles for 125 bodies, have been completed. There are a number of springs on the property, forming a creek, so that water scenery will vary the landscape. It is expected that the cemetery may be opened next spring.

\* \* \*

In speaking of the care of cemeteries *The North American Horticulturist* says: It is a deplorable fact that the majority of our cemeteries and parks do not receive the proper care and attention. Cemeteries are not merely burial places for the dead, but consecrated ground, where those are resting in peace whom we dearly loved in life, whose memory we cherish and whom we wish to honor in death by making the cemetery a place of beauty, where nature is in harmony, and awakens sweet memories and thought of a blessed reunion in the future. Where the graves and other surroundings, such as paths, trees and flowers of a cemetery are neglected, there it is painful for a sensitive mourner to abide."

\* \* \*

The storm on the first of the month had disastrous effects on the trees at the National Cemeteries in the vicinity of Washington. Trunks of trees were lying across many of the tombs at Arlington, and hundreds of mounds required repairs. Thirty trees, mostly oaks, which had withstood the storms of more than fifty years, were laid low at the Soldiers Home Cemetery, and at the grounds of the Home three hundred trees were counted fallen, and it will take years to make good the destruction. In Oak Hill Cemetery the trees on each side of the monument erected by the late W. W. Coreoran, in memory of John Howard Payne, author of "Home, Sweet Home", were uprooted but did not injure the monument.

\* \* \*

Fall work is now in active progress in cemetery and park, and ever busy superintendents are retrospectively meditating on their achievements of the passing season, while pondering over plans for next years work. But there is such a growing sentiment of pleasure in landscape effects taking hold of the people, that it is time to take note that the unequalled brilliancy of fall effects on the American landscape will require that attention should be given to our cemeteries, so that right up to frost time every care should be taken to preserve as long as possible the frequent beauties of the season, and not only to preserve what may be at hand, but to provide such plant material, looking to fall effects. This will increase the superintendents field of endeavor but it will repay the outlay.

\* \* \*

Among the items of interest contained in the annual report of the cemetery of Spring Grove, Cincinnati, O., are the following: Total receipts including balance from last report, \$86,256.30; disbursements \$82,847.83. The fiscal year ends September 30 and during the year then expiring 104 lots and 29 fractions were sold, an area of 46,312 sq. ft., and the receipts from sale of lots amounted to \$35,558.30. The receipts from interments, foundations and single graves amounts to \$21,551.74. The interments to date are 59,750, single graves occupied 11,661, and the number of lot holders 9,645. There was expended for labor, materials, watch and gate keepers \$24,240.13, and the total days labor performed on the various work connected with the cemetery, was 16,822. Accurate records of rainfall, temperature and other data are carefully kept at Spring Grove.



The Nebraska State Cemetery Association has been organized for the purpose of disseminating a knowledge of cemetery management, with the following officers: President, R. H. Oakley, Lincoln; Vice-President, J. Y. Craig, Omaha; Secretary and Treasurer, H. I. Plumb, Omaha; Executive Committee, J. Y. Craig, W. D. Hill, Beatrice, J. H. Derby, Bellwood, and president and secretary ex-officio members.

\* \* \*

According to the *Hartford Times*, All that remains of the apostles of Christ, are in the following places: Seven are in Rome—namely, St. Peter, St. Philip, St. James the Lesser, St. Jude, St. Bartholomew, St. Matthias and St. Simon. The remains of three lie in the kingdom of Naples—St. Matthew at Salerno, St. Andrew at Amalfi and St. Thomas at Ortona. One, St. James the Greater, was buried in Spain at St. Jago de Compostella. Of the exact whereabouts of the remains of St. John the Evangelist there is much dispute. St. Mark and St. Luke are buried in Italy, the former at Venice and the latter at Padua. St. Paul's remains are also believed to be in Italy. St. Peter is buried in Rome in the church which bears his name; so, too, are St. Simon and St. Jude. St. James the Lesser is buried in the Church of the Holy Apostles. St. Bartholomew in the church on that island in the Tiber which bears his name. The "Legends of the Apostles" places the remains of St. Matthias under the altar of the renowned Basilica.

The free distribution of bedding plants from the parks at the close of the season is becoming more general, and is looked forward to by numbers of people with glad anticipation. It is a good thing. Many a home is brightened, besides an active interest engendered in plant life by this easy acquisition of a few plants; and the numbers of plants thus to be distributed in all our large cities gives a fairly generous supply to all willing to call for them on the appointed days.

**Extracts from Rules and Regulations.**

The following are extracts from the Rules and Regulations of Maplewood Cemetery, the Springville, N. Y., rural cemetery, regarding perpetual care. Springville has some 2500 inhabitants and has adopted the park and lawn plan and perpetual care for its cemetery, overcoming all opposition to the changes.

"There will be set apart from the proceeds of each lot sold, excepting single grave lots, ten cents per square foot thereof, which shall be invested in approved first mortgage real estate securities, under the direction of the Committee on Investment, the income from which shall be used solely in taking care of and maintaining the lots in good condition and in embellishing the grounds, the principal of which shall remain a permanent fund forever, devoted to the purposes above named."

"The trustees may receive in trust from a proprietor of any lot heretofore conveyed to him, or her, any sum of money, the income of which shall be appropriated to the care and repair of his or her lot, according to the terms of trust expressed in form provided."

"The trustees may also guarantee the perpetual care and repair of lots heretofore conveyed upon the payment of such a sum as they shall deem sufficient for that purpose, a form for which is also provided. All such sums shall collectively, be placed in the Perpetual Care Fund, and invested as above mentioned."

**Legal.**

**UNSIGHTLY CEMETERY LOT NOT A NUISANCE.**

In an action brought by the Woodstock Burial Ground Association against a party by the name of Hager the claim was made that by reason of the condition of the latter's lot, it became and was a nuisance, and that the association had a right to re-

cover, as damage caused by such nuisance, the cost of filling the lot. The county court found that the lot "was unsightly and disfigured, and needed to be filled and graded to put it in proper and suitable condition." But this, the supreme court of Vermont holds is not synonymous with nor equivalent to a finding that the lot became and was a nuisance. It says that the law will not declare a thing a nuisance because it is unsightly and disfigured, nor because it is not in a proper and suitable condition, nor because it is unpleasant to the eye, and a violation of the rules of propriety and good taste, nor because the property of another is rendered less valuable. The law does not cater to men's tastes, nor consult their convenience merely. In the absence of a finding that the lot was a nuisance, the supreme court holds that a judgment for the owner of the lot was correct. At the same time it studiously refrains from expressing an opinion whether, if the finding had been that the lot was a nuisance, the association would have had a right of recovery.

**Spiraea Tomentosa Alba.**

The Spiræas are not only a useful but very attractive class of flowering shrubs, and in their variety of habit of plant and blossom and season of



flowering, they are valuable in many ways to the landscape gardener. The White Plume Spiræa, illustrated herewith, is something new, for which we are indebted to Wm. H. Harrison & Sons, Nurserymen, Lebanon Springs, N. Y. This plant forms nice

clumps, two to three feet high, and blossoms freely during the hottest of mid-summer, which makes it a desirable addition to the list of flowering shrubs. It is very showy as a bush for massed plantings, and is also good for cut flower work. The blossoms are in color a delicate pure white, arranged in dainty, open, plummy spikes. The leaves are firm and tomentose, like the pink variety, and stand drouth and dust without injury.



### Association of American Cemetery Superintendents.

G. W. CREESY, "Harmony Grove,"  
Salem, Mass., President.  
ARTHUR W. HOBART, "Lakewood,"  
Minneapolis, Minn., Vice-President.  
F. EURICH, Woodlawn, Toledo, O.,  
Secretary and Treasurer.

### Publisher's Department.

Park Commissioners and Cemetery trustees are requested to send us copies of their reports.

Photographs and descriptive sketches of interesting features in parks and cemeteries are solicited from our readers.

The Massachusetts Horticultural Society 101 Tremont street, Boston, Mass., desire to obtain as soon as possible the first three numbers of volume 1 of the *Modern Cemetery*, and also the Index and Title page of same volume.

The Pasadena & Pacific Railway Co., Los Angeles, Calif., is desirous of obtaining the addresses of cemeteries having an electric or other railroad operated through them, especially on which funeral trains are run.

Mrs. Fanny Copley Seavey, whose contributions to these columns have made her familiar to our readers, has been visiting this month the cemeteries at Lexington and Louisville, Ky., and illustrated descriptions of these cemeteries from her pen will in due course appear in PARK AND CEMETERY. Mrs. Seavey will visit other cemeteries in the near future.

Leonard W. Ross, for many years Superintendent of City Cemeteries of Boston, has entered into partnership with Herbert A. Horton, under the firm name and occupation of Ross & Horton, Landscape Architects. Their location is Tremont Building, Boston.

A call has been made looking to the formation of a national society of gardeners. It emanates from the New York Gardeners' Society, and information may be obtained by addressing James I. Donlan, secretary, 52 West 28th street, New York City. In the call the necessity for a national society is attributed to the infancy of horticulture in this country, and that its development depends on the gardeners; while successful horticulture meets so many obstacles due to climatic differences and local peculiarities. It reiterates the advantages to be obtained by association, such as the interchange of experience and ideas, personal acquain-

tanceship, and the possible raising of the standard of the profession. Those interested are earnestly invited to assist in the project.

Missouri Botanical Garden. Seventh Annual Report, St. Louis, 1896. This annual volume from the Missouri Botanical Garden, not only contains the reports of the Trustees carrying out the will of the late Mr. Shaw, in themselves of great interest, but also the results of investigations and researches, and the progress of its educational features. Among the contents of the present volume are three papers on Botanical subjects, and an address by Dr. Henry Wade Rogers on "the value of a Study of Botany." The subjects are liberally illustrated.

The By-Laws, Rules and Regulations printed for distribution by the Springville N. Y., Rural Cemetery Association, was accompanied with a photograph of the front of the grounds, which shows the care bestowed upon the property. The Secretary in a letter says: PARK AND CEMETERY has been of "immeasurable assistance in bringing our Board to adopt the feature of Perpetual Care." He says the arbitrary features at first appeared objectionable, but the general sentiment has entirely changed and it meets with entire approbation. The cemetery now contains twenty-five hundred burials which is about the number of inhabitants.

There has just been issued, published by the Illinois Engraving Co., Chicago, *Souvenir of Lincoln Park, Chicago*, Price 25 cents. It is profusely illustrated with excellent half-tone engravings from photographs taken on the ground, and with letter press interesting in matter as in typographical execution, it makes a handy and attractive compendium of the features of Lincoln Park which have made that resort of world wide reputation.

In referring to PARK AND CEMETERY in connection with some comments on the care of cemeteries and parks, *The North American Horticulturist*, published at Monroe, Michigan, recommends it as "deserving of wide circulation" and "an exceedingly valuable help in righting the matters referred to."

#### RECEIVED.

Second Annual Report of the Board of Trustees of Pleasure Driveway and Park District of Peoria, Ill., for fiscal year ending June 1, 1896.

Revised list of premiums offered by the Horticultural Society of Chicago, to be awarded at the Annual Fall Exhibition, November 10th-14th, 1896.

The Northampton Works; Illustrated Catalogue of Dumping Horse Carts, Sprinkling Carts, etc., Manufactured by Hobson & Company, Tatamy, Pa. Principal office, No. 4, Stone street, New York. This catalogue is fully illustrated and the many types of wagons, etc., described. The dumping cart is an exceedingly useful article in many respects; its lightness, facility of handling, and adaptability in confined situations should recommend it. With wide tires it could be made a great labor saver in clearing up in park and cemetery work.

From B. D. Judson, Supt. St. Agnes Cemetery, Albany, N. Y., Announcement to Proprietors of Lots Concerning Perpetual Care of Lots.

#### CATALOGUES.

Catalogue No. 37. Autumn, 1896. Choice Hardy Trees, Shrubs, Bulbs and Plants for Fall Planting. Fred'k W. Kelsey, 145 Broadway, New York.

Assignee's Sale of Hardy American Plants. Highlands Nursery, Kawana, N. C., offered without reserve. Thomas F. Parker, Assignee, Kawana, N. C.

T. V. Munson & Son Nurseries Catalogue, Denison, Texas.

Funk & Wagnalls Company, New York, have just received a single order from one firm for 100,000 copies of their celebrated "*Standard Dictionary of the English Language*," amounting at retail to nearly one and a quarter millions of dollars. This is the largest single sale of so large a work ever made in America. Previous to this one large transaction, over 100,000 copies had been issued, and the company is still receiving many large orders from its subscription agents throughout the world.

The advantages of autumn planting and transplanting for deciduous trees and shrubs and many other plants cannot be overestimated; and especially in latitudes where a considerable rise of temperature succeeds, comparatively suddenly, the frosts of winter. It takes time to repair the injuries to plants and trees occasioned by the cutting of roots and fibres when taking them up for removal, and the fall affords the opportunity with less risk than any other time of year. The cut roots and rootlets can become calloused, and probably other fibres will be thrown out before freezing to help withstand the effects of the change. Nursery catalogues nowadays contain much valuable information on plant life and in that of the Parsons & Sons Co., the well known Kissena Nurseries, of Flushing, N. Y., this question of fall planting receives considerable attention and valuable suggestions are given.



# PARK AND CEMETERY.

FORMERLY THE MODERN CEMETERY.

A Monthly Journal Devoted to Parks and Cemeteries.

R. J. HAIGHT, Publisher,  
334 Dearborn Street, CHICAGO.

Subscription \$1.00 a Year in Advance. Foreign Subscription \$1.50

VOL. VI. CHICAGO, NOVEMBER, 1896. No. 9.

## CONTENTS.

EDITORIAL.....	359
*THE LEXINGTON CEMETERY, LEXINGTON, KY.....	360
*GARDEN PLANTS, THEIR GEOGRAPHY, XIII.....	364
NOTES.....	365
*SOUTH PARK, QUINCY, ILL.....	366
THE TOMB SPIDER OF ITALY.....	367
A MORE RATIONAL VIEW OF DEATH.....	367
*THE ANNUAL FLOWER SHOW, CHICAGO.....	368
*ROCKERIES AT PINE GROVE CEMETERY, LYNN, MASS.....	370
*VILLAGE IMPROVEMENT.....	371
PARK NOTES.....	373
CEMETERY NOTES.....	374
EFFECT OF ELECTRIC LIGHT ON TREES.—LEGAL.....	375
PUBLISHERS DEPARTMENT.....	376

\*Illustrated.

MANY of the discussions and notes brought out at the recent convention of the Association of American Cemetery Superintendents at St. Louis, bore evidence of the value of the suggestions made from time to time in these columns. The rapid progress in the higher development of our cemeteries and methods of cemetery management is really remarkable, and it is only due to the progressive and enlightened spirit of the American people to say, that when they properly comprehend the propriety, to say nothing of the necessity, of improvement in the conditions of our cemeteries, advance is the watchword. Now, in order that the people may be brought to understand and appreciate the aims of cemetery officials under the new impetus, it is apparent that they must be supplied with the necessary information to incite their co-operation, and it goes without saying that the most effectual and forceful medium to this end is the local press. It is a matter for congratulation that throughout the country more publicity is now being given to cemetery affairs, and much good has already been derived from it. But much has still to be done, and a more active effort must be made by cemetery

officials to interest their local papers in the work. When we think the matter over carefully it seems as though the cemetery should receive as much attention at the hands of the local editor as the park, but for different reasons. The park is an essential feature of our civilization; the modern cemetery a necessity; and while the latter has found its best development under quasi public corporate management, it is nevertheless a public function, and a most prominent indicator of the degree of civilization of our people.

CIVILIZATION in its broader lines advances in epochs, certain well defined periods marking the development of certain phases. So, it may be said, that its details progress in like stages, which appear after the lapse of years to be clearly outlined and distinct from successive yet evolved sequences. And so being particularly interested in landscape gardening, we may look upon it as having begun, in American horticulture, with fruit culture. This seems to have been closely followed by floriculture, which developed into gardening on more pretentious lines, until to make our parks and cemeteries more attractive and refining, landscape gardening has reached its present advanced position in this country. But the progressive idea involved is yet active and is reaching out to impel the people to become still more interested in nature and nature's ways, as related to landscape work, by establishing in our principal cities a botanical garden as part of the park system. And this is not yet all, for in connection with our school system a suggestion is broached to encourage the study of plant life by the creation of botanical gardens, of greater or less extent, of easy access to our young people. There is scarcely a limit to the extension of the idea, for such gardens, in all our villages, would not be difficult of attainment within reasonable bounds, and what an incentive and education to village improvement societies would such grounds be! This is not advocating an unreasonable suggestion, for in another column it will be observed that Russia has in many of its provinces a complete system of garden and forest education attached to its village schoolhouses. So we cannot flatter ourselves with very great originality, even in this advanced proposition.



### The Lexington Cemetery, Lexington, Ky.

The Lexington Cemetery Co. was organized in January, 1849, and the cemetery dedicated June, 25, 1850.

The original tract, consisting of forty acres of beautifully undulating ground, partly covered by



OFFICE AND CHAPEL.

an indigenous growth of Oaks, Ash, Beech, etc., was laid out by a Frenchman named Eapradelie (if I decipher his signature correctly), who was Maximilian's chief engineer in Mexico. It now comprises 106 acres, 50 of which have been added within a few years.

From the outset the management has been in the hands of a Board of Trustees, chosen from the prominent men of the city, who have taken pride in the cemetery, and have served it faithfully without money or price, the superintendent being the only official who draws a salary, and the funds have been so well managed that on Jan. 1, '96, the assets amounted, in round numbers, to \$84,000. There are no liabilities except the current expenses.

\* \* \*

The policy of the management has been to charge only enough for lots to maintain all occupied ground, no perpetual care fund being asked for from any purchaser. And this practice is strictly adhered to, so that the largest lots and single graves receive precisely the same care, viz., *all* graves, grass, trees and shrubs are kept in good condition, and all occupied ground presents an equally attractive appearance.

\* \* \*

In 1890, a handsome building was erected at the entrance to the grounds. It is of the best quality of Bedford stone, and contains the well lighted, spacious and pleasant office of the superintendent, with

a large fire proof vault, a commodious, attractively furnished waiting room with toilet rooms adjoining, and a roomy chapel with bowed front containing three windows of stained glass. One of these, by Tiffany, is beautiful in design and in coloring. It represents Joseph holding the child Jesus. The expression of the child's face is charming. All of the rooms in the building are supplied with open grates.

\* \* \*

The record books in the big fire proof vault show an excellent system of records. They are profile ruled, the space between lines representing one foot, and the lot boundary of each grave is outlined in red, and the names written directly in the spaces so enclosed. The name of the lot owner is written in the margin, and a space at the foot of each page is reserved for the owner's remarks. So that reference to one book gives all details. This book corresponds with the record book of deeds and with large sectional maps, perfecting what seems a simple, yet complete, system.

\* \* \*

Mr. C. S. Bell has been superintendent from the beginning, except for an interval of one year, and has laid out all the ground that has, from time to time, been added to the cemetery, as well as had entire control of all planting from the outset. The nice way in which Mr Bell has put Downing's theories into practice, regarding the treatment of the surface of land, must appeal to every landscape artist. He has not undertaken to "unmake the character Nature has stamped on this piece of ground"—and the stamp is distinctly Kentucky species, variety Blue Grass region. And, when at its best, none can be either more beautiful or better adapted to cemetery purposes. Its flowing curves, perfect trees, and wonderful turf combine to make a quiet, poetic and satisfying landscape. And from the outset Nature has been respected here as in but few rural cemeteries, not excepting those of modern origin. This is due to the admirable taste and judgment displayed in the design and regulations, and to the uncompromising oversight exercised from the beginning by the efficient superintendent.

Fences, copings and visible boundary lines of every kind, have always been prohibited (*fancy that* having been thought of, and insisted on in 1850!) and while tall head stones are too numerous, lot owners have for many years been encouraged to use lower ones, and the use of foot stones has been so vigorously discouraged that they are comparatively scarce, even on the older sections. Other important factors in producing the open, park-like aspect of this cemetery are found in the peculiar plan followed of



making all lots rectangular, regardless of the shape of the sections; and the very unusual, if not unique system of selling all lots at a uniform price (which is now thirty-five cents per square foot) throughout the cemetery.

\* \* \*

In Mr. Bell's opinion, the last feature secures an even distribution of monuments, because purchasers are led by it to feel that one locality is just as desirable as another, and those who intend to erect costly monuments, naturally seek sites that will isolate and set them off to advantage, while those who cannot afford expensive stone work usually select lots near those having good monuments, thus securing the doubly desirable end of an even distribution of monuments, and the open, uncrowded effect ad-

surroundings of the section, and as all of the unsold is space it is utilized either as open lawn or for decorative planting, it is a simple matter to grow a background of trees where it will serve to enhance the appearance of every lot in the section. Likewise with shrubs or specimen trees, they can be introduced where they will improve the scheme and have room for proper development.

\* \* \*

Beside these reserve spaces and the margins on avenues there are plots, mostly approaching triangles in shape, that occur at the intersection of diverging drives, that are wholly reserved for decorative planting, and so are all of the so-called "sinks" characteristic of the limestone districts of Kentucky,



JUNCTURE OF OLD AND NEW GROUNDS.

vocated by those who endorse the lawn plan, and that without apparent effort on the part of the management. The system seems to have advantages for, as it stands, the oldest part of the ground looks far less crowded and stony than any old cemetery I have seen; in fact it only needs low markers and level graves to make it a modern cemetery.

\* \* \*

Drives are rather numerous, because Mr. Bell's experience leads him to disapprove of large sections. The main avenues are 42 feet wide from lot to lot with a middle macadamized section twenty feet in width, and the intersecting avenues 28 feet wide with an 18 foot strip of macadam. This includes a margin of six feet on each side of main and four feet on intersecting avenues that is reserved for sward or planting. The average width of sections is 300 feet, and they are of all shapes: circular, oval, triangular, etc. Lots average twenty feet square.

\* \* \*

The idea of making all lots rectangular without reference to the shape of the sections, seems a happy one. By nice planning the larger part of the unsold space in any section can be thrown to one side or the other, as best suits the location, shape and

of which there are several large ones within the enclosure.

\* \* \*

These "sinks" offer opportunities for ornamental work that have been fully utilized. Some have been excavated and form ponds; the sides of the deepest one are occupied by the few vaults contained in the grounds, and others are given over to what is probably the most effective planting in the cemetery. In places their easy slopes are occupied by colonies of foxgloves, wild asters, coreopsis lanceolata and other flowering plants of wildling type naturalized among the abundant shrubs and vines; and hardy ferns in great variety find fitting homes in their well shaded nooks. On the rocky banks of others, clumps of Prickly Pear and Yuccas add to the picturesque effect. Over the face of the one occupied by vaults, English Ivy and Japanese honeysuckles find foothold and send down long, trailing draperies of leaf and flower to relieve the masonry at the entrances and lend grace and fragrance to this unusual landscape feature. The largest "sink" is on the line between the old and new grounds, and is delightfully planted with trees, shrubs and vines. At the side towards the old grounds near the upper edge of the basin-like



depression are some large dead oaks covered with Trumpet creeper, and towards them are grouped the larger trees. An outlying trio of these, standing at the bottom of the basin where moisture is retained longest, is composed of a Liquidamber, Swamp Maple and Scarlet Oak. They not only make a glorious bit of autumn color, but their selection and location are characteristic of the art displayed in the designing and planting of the entire grounds as far as carried out.

\* \* \*

The planting is strictly in harmony with Nature's stamp on the ground. Nothing has been introduced that is so foreign looking in itself, nor in its manner of use, nor method of growing, as to make it seem out of place in a Kentucky landscape. The landscape is made, it is in reality artificial, but it is so well done as to seem natural—and *that is Art*. The requirements of a Cemetery are given proper consideration, yet the right of trees and shrubs to develop the kind of beauty that nature intended them to have is not infringed but encouraged. No tree is either dwarfed or deformed to make it fit a given location. On the contrary each one is selected because of its fitness in size, habit and appearance for the location to be planted—and that is not only art but common sense as well. Fitness, indeed, being the underlying principle of art, and the best guide to applied art.

\* \* \*

Two broad sinks have been excavated for Lily ponds, and the contour of the surrounding ground brought into harmony with them, as can be plainly seen in the engraving showing the juncture between the old and new ground, the actual dividing line being beyond the pond seen in the picture. In the vicinity of the water Japanese Irises, hardy ornamental grasses and moisture-loving herbaceous plants and shrubs have already been introduced, and more are to follow. A fine example of this work being a wide, irregularly grouped field of Tritomas that had spread naturally in a moist, shaded locality and were a surprise in mid-October, flaming out through the grass.

\* \* \*

Kentucky is noted for its fine trees, so it is natural that the Lexington Cemetery should be rich in them. But the native growth in the old grounds has been re-enforced by many that are suitable to the climate and location and in harmony with the landscape. So we find not only the Sugar Maple, splendid in its rich October garment of crimson and gold, and the Water Maple in vivid scarlet crimson dress, but the soft Maple, (which is not used near graves because of its enormous spread of sur-

face roots), Wier's Cut Leaf which is esteemed as one of the best, a couple of good specimens of the English Gooseberry leaved, and a number of fine Norway Maples. The blue, green and white Ashes, native to the region, and in addition the upright and weeping Mountain Ash and the English Ash.

Besides the native trees there are seen in splendid form the Yellow Wood, American Holly, the best specimen being about 30 years old, twenty-five feet high and from fifteen to eighteen through and loaded with fruits; a Purple Beech that probably cannot be matched in the west being now thirty-nine feet high, thirty-eight feet across and branched close to the ground; a big Paulownia Imperialis between 25 and 30 years old, some very fine old Red Haws, large White Fringe trees that, with the Yellow Pines on the grounds, date from the days when mountaineers brought seedling trees and shrubs from the Kentucky Mountains and sold them in Lexington—the only nurserymen at that time in the State; several Magnolias, including *M. grandiflora*, which is, however, grown in shrub form by cutting back the main stem and allowing several shoots to grow up in a clump; as this form is better able to withstand the occasional severe winters; some very large Catalpas; Oriental Plane trees and others.

\* \* \*

The fine old Burr Oaks that are scattered through the old ground give character to the Cemetery. Of four measured, none were less than five feet in diameter three feet above the ground, and several Elms tested were each from four to nearly five feet through. These great trees are the favorite resorts of the many gray squirrels that live happily in the grounds—no one being allowed to molest or make them afraid. The pretty little fellows are a charming adjunct to this sylvan retreat, which is also loved by the birds.

\* \* \*

There are also splendid coniferous evergreens, including large old Yellow and White Pines (but the last, together with American Elms, suffer severely from the sleet storms that prevail here at certain seasons), Norway Spruces, among which are several of very large size, that are really beautiful, the first I have ever seen that deserve that much abused adjective, and I never expect to see any like them elsewhere. But Kentucky is a tree Paradise, and Mr. Bell is an expert grower, moreover he has such love and reverence for Nature that I've little doubt she lets him into valuable secrets that are unwritten pages to others. The Hemlock Spruce is the best all round conifer for the location and there are specimens here that make one envious; the Oriental Spruce does well, also the White Spruce that is an excellent Cemetery tree wherever it thrives



because it never grows too large; the Colorado and Douglas Blue Spruces both do finely; the Scotch and Austrian Pine are no longer planted because they only live about thirty years; there is one Cedar of Lebanon that is doing fairly, it is on the Clay plot near the monument; Oriental and Siberian Arborvitæ and Juniperus tamarisifolia do nicely; the Canadian Yew is fairly good; and some English Yews that are sheltered by larger evergreens from the sun are very good.

\* \* \*

A large amount of shrubbery is used and each kind is grown in quantity wherever it is introduced. The groups and masses are formed naturally, that is: Lilacs and other suckering plants are left undisturbed to spread at will, while Snowballs, Spiræ prunifolia and other easily rooting shrubs are layered at the tips of the outer branches to produce masses. Besides all of the good shrubs one sees in the north I noted a plant of Scotch broom (of which the Superintendent is naturally proud); California Privet, which winter kills to the ground in severe winters but grows again very rapidly; tree Box; Mahonia aquifolia, which is perfectly hardy and is used in abundance with fine effect; it blooms profusely in spring, its foliage is fine all summer and in the fall takes on rich bronze and mahogany tones; and Callicarpa purpurea. An extraordinarily fine specimen of the last impressed me as being one of the most ornamental fruiting plants I have yet seen. It was planted at about the time of the beginning of the Civil war and has been killed back several times in severe winters. It is now five or six feet high and ten feet across and formed a mound-shaped mass of gracefully drooping branches loaded with small circular clusters of violet colored berries, an exquisite and uncommon color among fruits. It is very attractive.

\* \* \*

Most of the planting in the new ground remains to be done, although many specimen trees are already established as well as numerous boundary plantations of trees and shrubs, including numbers of evergreens. Boundary plantations as screens are to be made a feature of the new ground an improvement on the original design.

The rich historic interest of Lexington centres in this cemetery.

About 1,000 Federals and 100 Confederates are buried here, each having a section; that of the Federals is marked by upright cannons as in National Cemeteries, and the Confederates by two monuments, a view of the more artistic being given herewith.

Among the best known names of those who sleep here are John C. Breckenridge, Vice President of the United States with President Buchanan; John Morgan, the famous raider whom Mr. Bell



CORNER OF POND.

speaks of as handsome, courteous and debonair; Robert S. and Eliza Todd, the father and mother of Mrs. Abraham Lincoln, and a large number of her relatives; the mother of Henry Clay and, chief of all, Henry Clay himself—which, of course, alone makes the place famous.

\* \* \*

A detailed description of the Clay monument will be given in a subsequent issue of PARK AND CEMETERY, together with interesting matter pertaining to the life of Clay, some of which has not heretofore been published.

\* \* \*

When the City of Lexington fully appreciates the fine character of her cemetery she will probably furnish what it now woefully lacks—a fitting approach. Landscape work that has the approval of Elias Long is worthy of honor at home.



The present condition of the street for driving, for pedestrians and in general appearance is neither a credit to the city nor what visitors to the tomb of Henry Clay have a right to expect. The lack of a city park makes it the more incumbent upon the people to supply a well made, well kept approach in keeping with the quiet parklike beauty of Lexington Cemetery.

*Fanny Copley Seavey.*

### Garden Plants, Their Geography, XIII.

#### 9. CELASTRALES.

##### THE CELASTRUS, RHAMNUS AND CISSUS ALLIANCE.

This Alliance consists of 10 tribes, 98 genera, and 1,386 species. Trees, shrubs, climbers and herbaceous plants are included among them. The tropical species, of which the bulk consists, are largely evergreen.

Speaking generally they are more remarkable for handsome foliage and fruit than for beautiful flowers. Some genera, such as *Leea*, produce showy panicles of bloom, however. In the East Indies and in North America they are well represented by the grapevines, none of which are natives of Europe, although as largely cultivated there.

*Evonimus* is a familiar genus consisting of 45 species, distributed over Europe, Asia and America. There has been considerable diversity of opinion as to the origin of this name, and it seems that Bentham and Hooker have now dropped the euonymus spelling entirely. They are trees and shrubs, deciduous or evergreen, and occasionally half-climbers. In the autumn many of them are very ornamental with their scarlet, pink, or white fruit, which splits open and shows the still more brilliant seeds. *E. Europæus* is indigenous to Britain, and has yielded several varieties which are often seen in American gardens. *E. Americanus*, *E. Atropurpureus* and their varieties are common in the Atlantic states, and *E. occidentalis* is the western form. The evergreen *E. japonicus* is a much admired garden shrub at the south, and is quite hardy on walls as far north as New York, although it often gets its foliage scorched in severe winters. It has varied greatly, and forms with golden, white, and even pink coloring are in cultivation. *E. radicans* is a climber under favorable conditions, attaching itself to stonework like Ivy. There are green, silver, and rose-margined varieties. They may be used in the way of box edging.

*Pachystima* is in 2 species, natives of the Pacific coast.

*Celastrus* has 75 species, natives of Spain, Africa, Asia, Austria, Madagascar and North America. *C. scandens*, "bitter sweet," is the North American plant which has given its name to the whole alliance,



CELASTRUS SCANDENS (from *Garden and Forest*.)

*Reinia* is a monotypic genus from Japan.

*Myginda* has 8 species, mostly tropical; three species are found far south in United States territory. Other genera found in this country are *Schæfferia*, *Mortonia*, *Glossopetalum*, and *Maytenus phyllanthoides*. They are mostly found south, and on the borders of Mexico.

*Paliurus*, "Christ's thorn," has two species, one from Southern Europe, the other from Eastern Asia. They are but rarely seen, but will sometimes stand the southern winters.

*Zizyphus* has 65 species, mostly tropical. *Z. vulgaris*, however, has stood the climate of Central New Jersey for a series of years, and occurs on the property of Willard P. Perry, Esq., of Wilburtha, in a plant 12 to 14 feet high.

*Berchemia* has 12 species, mostly from tropical Asia, Africa, and Australia. *B. volubilis*, however, is found in the south, and is hardy as far north as New Jersey. It is a quick growing vine.

*Rhamnus*, "Buck thorn," has 66 species common to the temperate parts of Europe, Asia, America, and tropical parts of Africa. Some species make good hedges.

*Hovenia dulcis* is an evergreen tree from Japan, it lives at Baltimore or perhaps further north, but loses its foliage.

*Ceanothus* is a good sized genus of forty species, mostly from the south and Pacific states. *Ceanothus Americanus* is the "New Jersey tea." The French gardeners think very highly of some of



the larger blue flowered California and Mexican species.

*Colletia* has 13 species of singular spiny small trees and shrubs, chiefly from Peru and Chili. *C. cruciata* is hardy in the south of England. *Adolphia infesta* and others of the affinity are found in Southern California and along the Mexican border in Texas. (See illustration in October issue).

*Pomaderris* is a genus of creamy or yellow flowered shrubs 22 species of which are natives of Australia and New Zealand. Many of them are summer flowering, and where there is glass, are worth remembering.

*Vitis*, "grape vine," has 30 species, altogether Asiatic and N. American I believe. They are now cultivated in all the warm regions of the world, and are so familiar as to need no description.

*Ampelopsis* has 13 species from Asia, and N. America. Our plant is the well known "Virginia creeper."

*Cissus* is a large tropical and sub-tropical genus of 220 species. Some have very handsome foliage and should not be over-looked for shady spots in the sub-tropical garden.

*Leea* are mostly shrubs in 44 species, from Asia, Africa, Australia and the Mascarene Islands. Being tropical they are of course tender.

*James MacPherson.*

Trenton, N. J.

---

#### Notes.

For the successful cultivation of garden vegetables the use of chemicals and minerals is much better adapted, says Mr. Andrew H. Ward, than that of animal excrements or stable manure to supply in sufficient abundance and in the most available and cheapest form the necessary constituents found wanting in soil, or abstracted slowly from those long under cultivation by successive crops. There is a marked difference to be observed between vegetables grown upon soil where chemicals and minerals are used and those where stable manure is employed, the former being less watery, more solid, of better quality, texture, aroma and flavor. Pig's dung is characterized by an exceedingly unpleasant odor, which, when applied to the land, it imparts to the crops, and especially to the root crops which are manured with it. Even tobacco, when manured with pig's dung, is so much tainted that the leaves subsequently collected are unfit for smoking.

Sickness resembling typhoid fever has been caused in horses and cattle who were pastured on land where sewerage was used, and may not vegetables grown in soil where effete matter is used be one reason for the prevalence of this disease? If so,

it is at once prevented by removing the cause, while by using the necessary chemical and minerals adapted to the various crops and soils no loss is sustained by the market gardens; rather are they helped to a strong and more vigorous producing capacity of larger and better crops, and at a less cost than the use of stable manure entails, taking everything into consideration.

\* \* \*

The same authority above quoted also states that lawns can be kept green and thickset without the use of stable manure. City and village people who have a few square rods of grass usually imagine it necessary to keep the plot covered for weeks with badly scented and ill-looking manure, when the fact is that one-half the money's worth of nitrate of soda and powdered phosphate of lime will answer better and create no nuisance. They furnish to the soil what is most needed—an alkali, phosphoric acid and nitrogen. Both of them are inodorous and show their effects immediately on application.

\* \* \*

The care of cannas over winter is thus described by J. D. in *The American Florist*: In lifting cannas take up as much soil as possible with the clumps and place under the benches in the greenhouse. They keep best in a house with a temperature of 40 to 45 degrees. Never water them when in this temperature and carefully avoid drip from the benches. If in a house with a higher temperature than above the usual hosing and syringing in such a house will generally supply sufficient moisture to keep the clumps from drying out, but they should be examined frequently and moisture given where a tendency to dry out is noted.

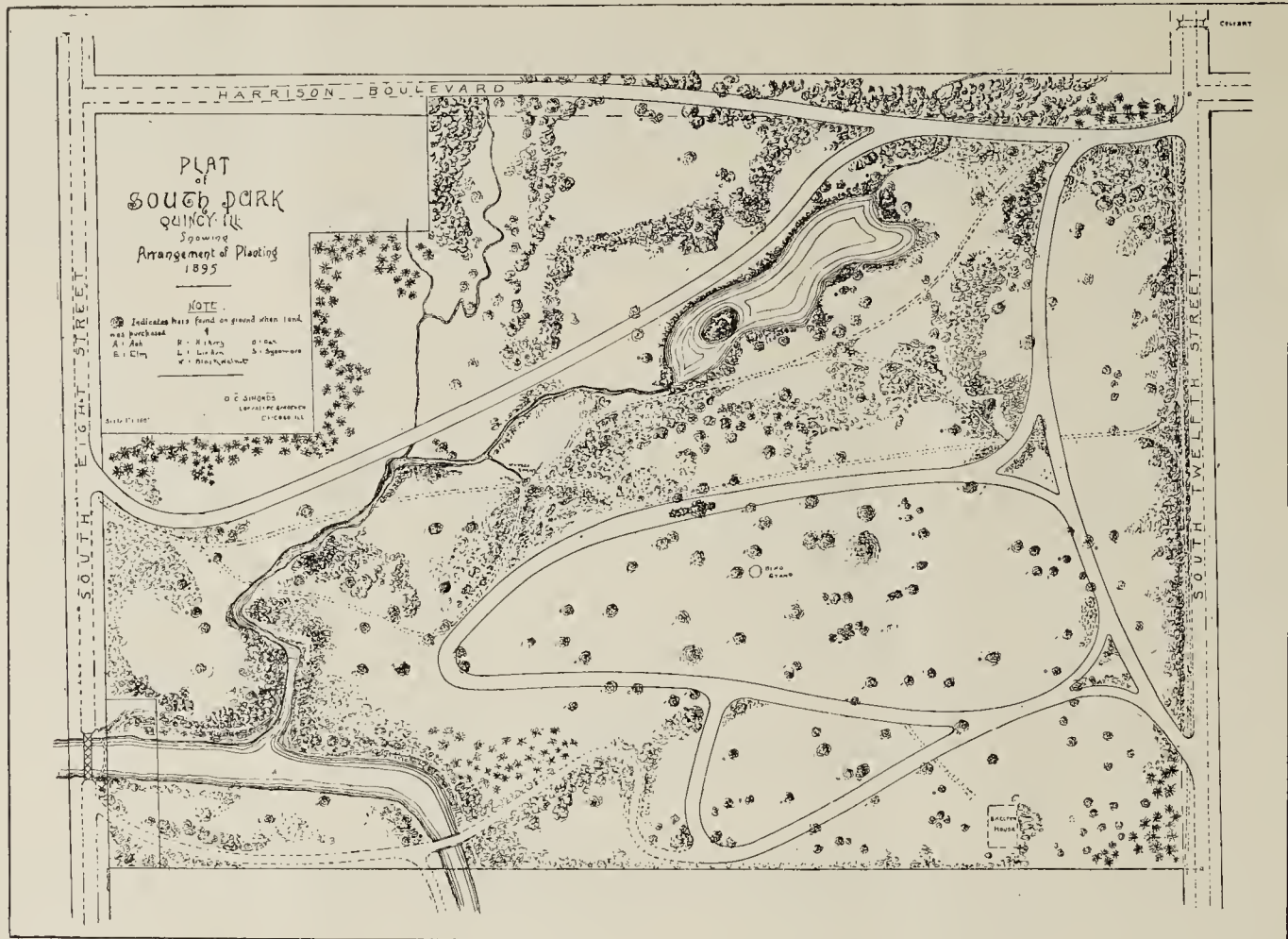
\* \* \*

It has only recently been that the comparative scarcity of sweet-scented flowers has been pointedly noted—and what is more remarkable in many large families of flowers, there will generally be found one or two species worthy of being designated as "odorata" among the scores of odorless species. The genera, *viola*, *begonia* and *reseda*, in which are found the *mignonnette* and *violet*, are familiar instances. But whoever heard of sweet-scented *phlox* among the numerous species of that genus? But Miss Margaret Thompson of Minneapolis reports *phlox caespitosa*, a spring flower of the Black Hills, is very fragrant. — *Meehan's Monthly*.

\* \* \*

From the Alps came the *ranunculus* and from Italy the *mignonnette* in 1528, *rosemary* from the south of Europe in 1534, the *jasmine* from Circassia





SOUTH PARK, QUINCY, ILL.

about about 1548. The year 1567 saw the introduction of four time-honored favorites—the auricula from Switzerland, the pink from Italy, the gillyflower and carnation from Flanders. Spenser, by the way, in the “Shepherde’s Calendar” (1579) classes the carnation, which he calls “coronation,” with the purple columbine and the gillyflower as lovers’s flowers. Now, the carnation is generally supposed to have deived its name from the carnation or flesh color of the original species, but the word used by Spenser suggests that “carnation” is merely an abbreviation of “coronation,” in allusion to the appearance of the flower, and its specific name, *betonica coronaria*.—*Chambers’ Journal*.

#### South Park, Quincy, Ill.

The accompanying plan and illustrations of South Park, Quincy, Ill., will largely aid in an appreciative understanding of the following brief suggestions concerning its design and possibilities. As has before been stated in these columns the park has been laid out from the design of Mr. O. C. Simonds, Landscape Gardener, of Chicago.

It comprises a tract of land of a little over fifty acres, situated, as its name implies, in the south part of the city. Its leading features are the varied surface of the ground, the fine growth of large for-

est trees, including oaks of various kinds, American elms, black walnuts and others, a spring of pure water, and two small streams which have worked their way through limestone rocks. From a bluff on the south side of the park there is a fine view of a rocky glen and a glimpse of the Mississippi River. In making a design for the improvement of this park, the aim has been to preserve all the natural features which have for years made the land attractive to the residents of Quincy; to make drives and walks so that these features can be more easily seen;



A NOBLE TREE.





A ROCKY GLEN.

to increase the water surface and the variety and extent of foliage, and to give greater seclusion by shutting out buildings with belts of planting.

It is hoped that some day South Park will be one of a series of breathing places scattered around the outskirts of the city and connected by attractive driveways. The location of Quincy on a high bluff directly on the bank of the Mississippi gives it an unusual advantage in its river scenery. Quincy is also fortunate in having an energetic Park and Boulevard Association which will do all that can be done to preserve for the benefit of the inhabitants and their guests the beautiful scenery with which the city is surrounded.

#### The Tomb Spider of Italy.

The people of Italy believe in the existence of a wonderful creature which, for the want of a better name, is called the tomb spider, says the *Pall Mall Gazette*. The entomologists know nothing of this queer beast and declare that it exists only in the fancy of the superstitious persons and those whose curiosities or business makes it necessary for them to explore old ruins, tombs, catacombs, etc. According to the popular account the tomb spider is of a pure white color, has wings like those of a bat, a dozen horrid crooked legs and a body three or four times the size of the largest tropical American tarantula.

The accounts of this queer insect and his out-of-the-way places of abode are by no means common, and on that account the information concerning him which we will be able to give the "curious" is very meager. Any Italian will tell you that such a creature exists, however, and that he is occasionally met with in the old mines and caverns as well as in tombs and subterranean ruins. The *London Saturday Review* has an article from a correspondent who was present when some Roman workmen unearthed

a church of the fifth century. He says: "We were standing by one of the heavy pillars that had originally supported the roof, when something flashed down from the pitchy darkness overhead and paused full in the candlelight beside us, at about a level with our eyes. It was distinctly as visible as a thing could be at a distance of three feet and appeared to be an insect about half the size of a man's fist, white as wax and with its many long legs gathered in a bunch as it crouched on the stone.

"Our guide had seen or at least heard of this uncanny insect of ill omen before, but was by no means reconciled to its presence, as his actions proved. He glanced around uncomfortably for a moment and then moved away, we following. It seems really a bit queer, but it is said that the strongest nerves give way in the presence of this insect of such ghostly mien. Even to-day this uncanny apparition is said to be an unclassified monster—an eternal mystery. When the grave spider is encountered by those opening tombs and vaults it is thought to be a 'sign' of death to one of the workmen or some member of his family."

#### A More Rational View of Death.\*

As a layman, speaking to those whose professional employment consists in providing and maintaining beautiful resting places for our beloved dead, I have chosen to speak to you by way of encouraging a more cheerful and rational view of death itself. If we can succeed in looking upon death as a friend, as Daniel French has so beautifully portrayed in his memorial tablet to the young artist Milmore, now set in bronze in Forest Hill cemetery, near Boston, and will generally admit that death is not inherently an evil, but next to life itself the greatest earthly blessing, then we might hope to maintain towards it a more cheerful and reasonable bearing. And this is the thesis I have assigned myself in this paper.

To appreciate the changed attitude of the world in this matter, and especially with reference to burial places, we should note at least three periods of the world's history in this respect.

The oldest form of worship was that of deceased ancestors whose spirits were supposed to forever haunt the ancient hearthstone and tomb, which were always near together. The maintenance of a perpetual fire on the one and the proper attention and care of the other kept the descendants rooted to the home of their fathers, and gave to these resting places of the dead a sacredness and inviolableness which has always characterized these spots in all nations, and in diminishing degrees even to the present day.

Following this came the doctrine of the physical resurrection of the dead to an endless life, which was thought to have been the original attribute of the race, and which was lost through the sins of our first parents, which doctrine still finds adherents amongst the less educated and less thoughtful classes, and at one time pervaded all Christendom. This doctrine added, if possible, to the sacredness of the body from which all life had departed, and made its perpetual preservation a thing altogether to be desired and a filial duty which was fulfilled as far as possible. This necessitated a place of repose, pending this wonder-

\*Paper read at the Convention of Association of American Cemetery Superintendents, St. Louis, Mo., September, 1896. By Prof. J. B. Johnson.



ful awakening, which should be sacredly preserved in undisturbed entirety from age to age until the resurrection morn, when Gabriel's trumpet should sound and these innumerable graves should render up their long-cherished and unviolated dead.

The present scientific age has dispelled both of these doctrines as tender illusions, for which the wish had been father to the thought. We have now ceased to regard the remains of our deceased friends as having any particular significance except as reminders of their living counterparts, and hence the preserving care of, and superstitious regard for these perishing, lifeless organisms, which formerly was a sacred duty, has now become merely a traditional and an entirely irrational custom. It is to be hoped the day is not far distant when cremation, the only rational disposition of the lifeless body, will be universally adopted in all civilized communities.

Another beneficent result of the more general prevalence of scientific knowledge is that the laws of this present world are coming to be better understood and accepted as wise and good. It was no meaningless or flippant remark of Margaret Fuller's when she said, "I accept the universe." For ages it has been considered the righteous thing to reject this visible, objective universe as a miserable failure, a vale of tears, a kind of way station where we are forced to tarry for a time in painful preparation for an endless existence in some other world, in which perpetual happiness and joy, or endless woe and torment were supposed to be prepared for all comers.

Now I do not care, as a scientific man, to commit myself for or against any theory of a future life, for the truth or falsity of which I have no sufficient evidence to enable me to formulate an opinion, but the absence of any decided views on this subject does not trouble me in the least, as I once supposed it would. What I cannot know I cannot be accountable for, and hence I choose to shape my course, and would wish all others to do the same, in accordance with the knowable things of this world rather than the unknowable, feeling satisfied that whatever the future has in store "no evil can happen to a good man in life or in death."

Assuming, therefore, that we may look upon death as a product of natural causes, the same as any other natural phenomenon, and that these causes are found in the fixed, and as we believe the beneficent, laws of the universe, let us examine into it as we would into any other aspect of the workings of nature's laws, to see whether or not it is the hideous monster it is commonly represented.

First we must remember that we must view it as a whole, and not simply in its exceptional or most painful examples. Like any other law, if the conditions of its operation are complied with it must of necessity operate, whether its action is beneficent or injurious. So with fire, which was regarded by the ancient Greeks as the greatest gift of the gods to man, and yet it may be his most destructive enemy. In fact every law of nature, of which man has learned, may work evil as well as good if its operating conditions are ignored, and yet we call them all wise and beneficent, and thereby we accept the universe, with death included, as a good and wholesome world, when properly understood.

Probably the great argument in favor of death as a law of the universe, is that hereby only can the race make progress. With the ancient belief in a golden age when man was perfect and immortal, no improvement was possible and hence death was not a necessary condition, but with the newer and now prevalent view of the evolution of the human species, progress can only come with infinitesimal gains from generation to generation and all our superiority to our less progressive "poor relations" lies in this evolution through innumerable births and deaths.

Prof. Fiske finds a very strong support in this doctrine of the "ascent of man" in the long period of infancy of the human

species. How much this developing period of childhood is fostered and stimulated by the fear of the death of the child on the part of the parent, he does not indicate, but if death did not exist we can all see how much this developing care of parents would be relaxed, and how the race might at once begin to degenerate. If death is then an essential condition of human progress, it must be pronounced good and not evil, and it is therefore a friend and not an enemy of mankind.

The subjective effect of this law on the individual is also most wholesome, when it is not regarded as an evidence of divine wrath or displeasure, or of an incomprehensible caprice. Remove it from the category of special providences, and it can be calmly viewed as the working out of the effects of natural causes. It must be regarded at times, however, as an unfortunate, sad, and pitiful result of the operation of a most beneficent law. These are the cases of "untimely death," to overcome which but stimulates the race, and which are rapidly being eliminated with the progress of science and the spread of its teachings. Even here death must still be regarded as the unexpected visit of a friend, and not as the stealthy stroke of an enemy. If we would all conscientiously contemplate the friendliness of death, not viewing it with fear and trembling as the great arch enemy of mankind, and as meanly stealing upon us as a thief in the night, but as coming quietly and in the most friendly and helpful way, leading us into the great unknown from which we have nothing to fear if we are not afraid to *live*, then we would not only welcome it when it comes to us, but we would regard the vanishing from mortal sight of our friends with a greater resignation and comfort. As a friend goes to a far country to live, as a loved daughter marries and leaves the home of her parents, as a child goes from its home to be educated, so should the bearing away of our loved ones by death be regarded.

Yes, in some respects we may say this last journey has its consolations which the others lack. We all admit there are many things more to be dreaded than death, and so long as we live some of these may possibly come to us, but when our dear ones are once confided to the care of this last friend, we are certain no further harm can come to them.

It is one of the unaccountable facts that while death has always been so feared and dreaded by the well, it seems to be always welcomed by the dying. The friendship for this unseen visitor then manifests itself, on the part of the passing spirit, and why then should we not also call Death our Friend? Surely, in a very true sense, those departed souls are nearer to us after this vanishing from outward sight than when clothed in flesh and blood. Proximity of body is no proof of commingling spirits. When the outward body has passed away then we feel that we can possess our friend entire, and our spiritual communion with the ideal and real friend is perfect and continuous, and nothing can now occur to break this perpetual bond and shaping influence.

The ever-present knowledge that death will come to us sooner or later is probably the greatest of all stimulants to noble endeavor. Were we certain of a continuous existence here we would always be inclined to delay action and await the development of events. As it is, we feel that no time must be lost or wasted—that the present is all that we are sure of, and that every passing moment must be consciously utilized to help complete the work of a life known to be short, and which may end at any moment. We are thus changed from indifferent drones to working members of the human hive, with the result that our own and future generations will receive some good thing or some added pleasure as a result of our having lived at all.

We also thus develop our own personality, and if an immortal existence awaits us when the friend of all mankind calls upon us, we will be certain to receive in some form a further reward for our faithful services here. The blessings of death



are therefore constant and perpetual, both here and hereafter, and if occasionally a few times in every life we are thereby stricken down by grief, and a sense of loneliness and loss almost overcomes us, we should be reasonable and remember all the benefits we and the world derive from this same Friend, who will one day call in turn for us.

Although it often seems as though lives were cut short in the midst of their allotted tasks, leaving them uncompleted, yet often the real benefit of a life comes only after it has ceased to exist. Then it is that the character wrought out in life is distilled into a spiritual influence which may accompany, pervade, and shape a thousand lives, as could not have been done by the embodied soul. If a feeling of incompleteness accompanies this influence, a thousand minds are stimulated to carry on what one had begun, and so the work grows and spreads by the death of its originator, as Christianity itself did when its founder was called away before his work had scarcely begun.

Then why should an air of gloom, of mourning, of sombre sadness pervade everything connected with death and the grave? Surely the dead are not honored in this despairing inaction. We honor them most by cheerfully lending a hand to complete the work they had begun, and to fill the void their departure had left in our midst. In this way we too may worship our ancestors, and to a much greater profit than in caring for their tombs and in ministering to the supposed wants of their departed spirits. Other losses are not to be repaired by mourning over them, then why should this be any exception to our common rule of conduct? There is but one answer to this question. It has become so fixed and universal a custom to do so that we should be considered heartless to abstain. To be strictly honest, one must admit, I think, that this is the case. No customs are so hard to change as those relating to death and burial. In these respects we are still in the barbarous stage. In these affairs, most pre-eminently matters of the heart, of private or individual concern, we act as though we took council only of public opinion and had no personal interest in the subject. We either affect a sadness and grief we do not feel, or we coarsely parade before the gaping crowd our crushed and bleeding heart strings. In other matters of the heart we maintain our privacy intact from our nearest and dearest friends as modesty and delicacy, and a due regard for our own self-respect require, but in all matters relating to death in the family, the conduct of funerals, and our mourning habits, we are bound absolutely to a series of customs at once irrational, barbarous and oppressive.

But, you may say, why should we be told again of these things which we all know and have long deprecated? I don't know that I can give you a good reason, and probably I should apologize to you for bewailing before you a state of things you would all gladly join with me or any one else in correcting. Perhaps it is because I have felt that you as a class of men, charged with caring for our places of the dead, may possibly do a little to impress upon the public, in an unconscious way perhaps, the feeling that death is a friend and not an enemy.

I believe, however, you are all trying to do this. I am sure it is not with your approbation or advice that our cemeteries look so much like charnel houses. You surely do not favor bedecking them with broken shafts, ghastly marbles, and weeping willows. On the other hand, I am sure you are doing all you can to banish these from our "Cities of the Dead," as they are now very properly called, and to bring in the place of these emblems of sorrow the brightest of flowers and the most cheerful foliage; the most beautiful and in spiring trees and the most restful and inviting landscapes; and in place of iron fences and stone vaults give us glassy waters and shady walks. Give nature a chance to cheer and sooth the disconsolate and wounded hearts which venture here to be again near the remains of their loved ones instead of wounding and crushing them anew with skulls

and cross-bones, lifeless marbles and ghastly sepulchres.

What I wish to see, therefore, in all matters pertaining to the final departure of the visible forms of our friends from this world is a general recognition of the following facts:

1. That all people should try to add to our common happiness, improvement and good cheer, feeling sure that the more we succeed in bringing heavenly happiness into this world the more likely we are to find a happy heaven in the next.

2. That death is the great friend and benefactor of the race.

3. That it comes only in accordance with the working out of wise and beneficent laws, and never as a special judgment, or by accident or through blind caprice.

4. That it should be received and respected as a friend and not reviled and hated as the insidious skulking foe of all mankind.

5. That all matters connected with death and burial should receive a more private, and therefore a more natural and cheerful treatment.

6. That the minds of those who mourn should be turned to the future rather than to the past, since looking backward, except to range a course forward, is always profitless.

7. That the lifeless bodies once inhabited by our friend should be reduced to their earthly elements in the most rapid and harmless manner possible.

8. That if these material remains are preserved in the bosom of Mother Earth, it be in spots unobtrusively marked in beautiful parks, where earth and sky, flower and foliage, lawn and lake, birds and butterflies shall each and all bring healing and joy to the crushed and bleeding hearts which will resort thither as a thirsty traveler to rippling waters.

---

#### Luminous Plants.

Several varieties of the vegetable kingdom are luminous in a greater or less degree. One of the fungi, which is not at all uncommon on the walls of damp, dark mines, caverns, etc., occasionally emits sufficient light to admit of the reading of ordinary print by it. The emission of light from a common potato when in a state of decomposition is sometimes very striking. Several of the Italian plants and grasses are also luminous, and it is said that in 1845 the mountains near Syree were nightly illuminated by their means. The root stock of a plant from the Ooraghum jungle, supposed to be an orchid, possesses the peculiar property of becoming luminous when wetted, while when dry it is quite lusterless. The hairy red poppy, the nasturtium and the double marigold are also luminous to a certain degree.—*Boston Traveler.*

---

Naworth Castle, England, the border seat of the Earl of Carlisle, has just lost one of its historic possessions in the shape of a venerable oak tree, which fell, unable to withstand its immense top growth. The tree stood at the entrance gate of the castle, and was the one upon which "Belted Will" Howard, in the beginning of the seventeenth century used to execute the marauding borderers with whom he had to deal as Warden of the Marches and "Civilizer of the Borders."



### The Annual Flower Show, Chicago.

If there had been any lingering doubt, as a legacy of the World's Fair, on Chicago's future æsthetic possibilities it must have vanished during the Flower Show, or Chrysanthemum Show, as one may choose to call it, which has just been held, and which has become one of the annual events of this progressive city.

With greatly enlarged space compared with previous exhibitions; with increasing interest by those citizens whose participation in the preliminaries means virtual success under any circumstances; with a magnificent and varied display of flowers and plants and the necessary accessories to bring out their excellencies; and finally with public appreciation at least equalling enthusiastic anticipa-



A GROUP OF SHRUBBY CHRYSANTHEMUMS.

tion; it will have to be conceded that even in flower shows Chicago has no rival.

Of course the chrysanthemum was the principal feature, if we might except the gentleman affectionately termed "Uncle" John Thorpe, who has the reputation of having introduced this floral wonder to the western world. Of the chrysanthemums there were not so many new flowers as greater development of older ones, but what there were of new ones were remarkable for size and other points.

Roses, carnations, orchids, palms and decorative plants helped with the chrysanthemum to make a most meritorious and artistic exhibition. The collection of orchids of E. G. Uihlein, the park commissioner, attracted a great deal of attention and was marked by some priceless gems of this mysterious and marvelous plant. A splendid collection of palms, ferns and other decorative plants from the conservatory of Mr. George M. Pullman did great credit to his gardener. Many of these were relics of the World's Fair.

The advances made in the cultivation of the carnation in form, size and color were excellently well displayed, the masses of color in varying shades being actually remarkable.

The presence of the collection of plants from the West Side parks was suggestive. It not only showed the variety of beautiful plants collected and cultivated for the people's pleasure, but it was an evidence that the park conservatories might well contribute to future exhibitions. Such exhibitions are an incentive to higher work and promote honest endeavor to progress as far as possible from year to year.

The decorative use of flowers was exemplified in table decorations, for which prizes were offered, and in which students from the Art Institute took an active part.

The Horticultural Society of Chicago is to be congratulated on the magnificent success of this recent effort—a success which will not only incite to increased effort in the future, but affords the gratification of assured public support in anticipation. A flower show is always a source of attraction for all classes of society, and it is a source



EXHIBIT OF THE WEST CHICAGO PARKS.

of entertainment, elevating and refining, and conducted with the addition of lectures and informal talks by practical men, a means of education also.

### Rockerries at Pine Grove Cemetery, Lynn, Mass.

The accompanying illustrations present certain features of landscape work, which from associations and suggestions always form an attraction wherever they may be placed. There are comparatively few locations where conditions are most favorable for the preparation or maintenance of rockeries or rock gardens, although it is, perhaps, possible with due knowledge, diligence and means at command to construct and cultivate them anywhere conditions admit at all. The rock gardens illustrated, of Pine Grove Cemetery, Lynn, Mass., on which Mr. Will-





iam Stone, the superintendent, has bestowed much attention are thus described by himself:

"I have three rockeries or rock gardens. The rocks or boulders, some of them weighing many tons, I have left undisturbed, except in making the paths, which only affected the smaller ones. Otherwise they remain as nature left them. How long ago they were placed one on the other, as many are, I do not know, and how it was done I have not attempted to study. I have had it explained to me several times by persons who did know, but after they were through I did not feel any better enlightened. Suffice it to say they are there, a sublime example of the handiwork of nature. In my attempt to beautify them I have brought from the adjoining woods hundreds of ferns and have also set many varieties of begonias and grasses, with Cannas and Caladiums here and there, together with some of our native plants, also from the woods.

I have made ponds with fountains and have furnished them with fish. The ponds are not large, of course. To add to their attractiveness I have



provided rustic seats in suitable situations, so that if one will walk in out of the sun and occupy one of these seats, listening to the water as it falls back in the pond, mingling its pleasant music with the song of the birds in the trees overhead; and if one can then turn his gaze upward and look through the branches, which have for their background the blue sky above, and be not inspired with the wonders of nature, he is entirely out of place in these beauty spots and should be banished to—I don't know where."

#### Village Improvement.

Suggestions on village improvement and the advocacy of Village Improvement Societies have received considerable attention in these columns from time to time. The success which has attended the efforts of such organizations, whether composed of women alone or bodies comprising both sexes, has been so marked where properly directed, that there would hardly seem any need to emphasize the propriety of their existence.

There are, certainly, very few small towns or villages in the whole country where concerted action of certain of its citizens, directed towards the improvement or beautifying of the place would not find plenty to do. Cleaning up objectionable localities, planting trees and shrubs—the trees along the thoroughfares, shrubs and trees in the bare and exposed spots at street intersections and elsewhere; perhaps a fountain in some neglected spot, and many features which a careful survey of the situation would suggest to those desirous of seeing their little town or village a beauty spot and the pride of the community.

Then there may be the village park or square and there certainly must be the cemetery, both of which offer abundant opportunity for the exercise of taste and energy, and like the rest of the work will return a hundred-fold for the labor expended. There is scarcely a limit to the field of village improvement and embellishment, for as the age advances and our civilization assumes higher forms and presents more elaborate requirements so must the work of the village improvement society proceed with it.

Ideas spread so rapidly nowadays; no sooner does a suggestion become established as a matter of value to the country, and hence to the community, than on every hand there springs up a sentiment favoring it. This at the present time seems to be the case in regard to arboriculture, and we note a suggestion that as trees are invaluable to humanity in so many ways, not the least in their availability for both use and ornament in our towns and villages, that our Village Improvement Societies



should establish in their park or elsewhere, a collection of greater or less extent, of trees and shrubs suitable to their locality. Such a collection would serve a double purpose. It would be an admirable adjunct of the public school, inculcating in the



ROAD SIDE SHELTER HOUSE FOR WATERING TROUGH.

minds of the young a love of nature, which above all things exercises that refining influence which is a necessary accompaniment of our development. It would also be of incalculable assistance in determining suitable material for the natural adornment of the place. This is worthy of serious consideration and should be a labor of love to the lover of nature.

But returning to a detail of improvement, and there are so many features of such work, we extract from *The Country Gentleman* an illustrated contribution of W. D., which speaks for itself, but is entitled a Roadside Watering Place:

"A community is 'sized up,' not only by the character of the farm buildings along the way, but by the character of the public highway as well, and one of the necessary adjuncts of a good highway is wayside watering places. If an effort is made to have these attractive, so much the better for the reputation of the community where they are situated. It is easy to make an attractive watering-place, for one can call in the aid of vines and shrubs. A simple plan is shown in the illustration. A hog-head contains the water that is brought to it by a pipe. The sides and top are boxed in, and a roof carried up over the whole. Over this, vines are trained until the little building is fairly hidden by them. It may be thought that this is considerable

trouble to take for a watering-place, but everything that enhances the beauty of a roadside enhances the value of the property adjacent to it, and increases the respect of travelers for those who live adjacent. Well constructed roads, well kept roadsides, attractive watering places and properly marked guide-posts indicate the vicinity of cultured, thrifty, up-to-date residents."

#### Food-Bearing Trees.

The Eastern Soudan, which has recently been annexed by France to its East African possessions, is a land of strange animals and strange growths. Its capital is Timbuctoo, sometimes called the Sacred City, and its chief river the Niger, says the *New York Journal*.

An explorer, M. Felix Dubois, has just made a very interesting journey up the Niger. This mighty river is in places so filled with huge aquatic plants that it has the appearance of being nothing but a great field under cultivation. There is, however, plenty of water for the native boats, and as they move through the vegetation they have the air of sailing on the fields.

The most curious feature of the Niger countries is the supply of food growing ready for use on the trees. The happy African of these parts does not even have to scratch the soil; he merely picks his food off a tree conveniently provided by nature.

The most important of the food trees is the karite, or butter tree. In appearance it somewhat resembles a pear tree. It attains, however, a much greater size. The branches grow in the form of a dome. The fruit from which the natives extract butter has a strong odor of chocolate.

M. Dubois first made the acquaintance of the tree when he was approaching a village. He was greatly surprised to notice a strong smell of chocolate and presumed some European traveler had arrived in the village before him. In this he was mistaken, but he followed the scent and arrived before a hut in which a brownish mass was boiling in a great earthenware pot. The natives were boiling karite nuts to extract butter from them.

These nuts are covered with a fruity growth, which has somewhat the flavor of a peach, and is eaten by the natives. After this is stripped off the nut is left to dry. It then becomes hard, and by color, smell and taste is almost identical with cocoa. The Soudanese, who know nothing about chocolate, only use the nut to make butter. In the whole Soudan it is the only form of grease used for food purposes. It is kept in great blocks, and has the advantage of never becoming rancid. It is a substance which in many respects is superior to anything known in civilization.



## PARK NOTES

Much activity is noted in Oakland, Cal., looking to the establishment of a system of parks in that city.

\* \* \*

Preliminary work on Bradley Park, Peoria, Ill., a recent gift to that city, is well under way; the Park Board has spent nearly \$8,000 on the work thus far.

\* \* \*

It is reported that the geysers in the Yellowstone Park are losing in force and activity, and some one predicts that fifty years hence there will be little left of them.

\* \* \*

A project is on foot in Iowa Falls, Ia., to connect the many beautiful spots in and about the beautiful city by a park system. Many interesting points will be included in the scheme.

\* \* \*

The village board of Herkimer, N. Y., is at work on the project of converting the old cemetery at the west end of Liberty street into a public park. This is an improvement long needed.

\* \* \*

Among the items of news connected with the Philadelphia small parks and squares, late in October, was the opening of bids for some 400 trees and 80,000 bulbs. Herein lies a promise of renewed beauty next spring.

\* \* \*

The Baltimore, Md., park board have decided that "permits" will be required for foot ball and other field games in the parks. Exercised with liberal caution this may be a wise conservatism, but therein "is the rub."

\* \* \*

According to the *Popular Science News* there are in France twenty-two botanical gardens; in Germany, thirty-five; in Great Britain and Ireland, eleven; in the Indian empire, nine; in Italy, twenty-two; in Russia, fourteen, while there are but five public botanical gardens in the whole of the United States.

\* \* \*

In a suit of the Louisville Park commissioners against that city to secure a tax levy made for the benefit of the parks for the years 1894-95, and which was withheld by the city, Judge Field has rendered a decision in favor of the commissioners which declared that the levy could not be diverted from the park to other purposes.

\* \* \*

Philadelphia is embarking in an extensive scheme of city park improvement, outlined by City Forester Lewis. Old trees are to be removed and new trees planted on a well thought out plan and not indiscriminately as heretofore. A large order for trees and bulbs has already been placed and it is probable that another will be given out later in the season.

\* \* \*

In our colder latitudes the object of the parks to secure recreation and pleasure to the people, does not fail by reason of winter rigors. It is now being recognized that winter sports and pastimes should be provided for in our public parks, and generally improvements are being effected to provide both the accessories and the comfort for the due enjoyment of the winter season.

\* \* \*

Alexander Hamilton Post, No. 182, G. A. R., is arranging to set out thirteen elm saplings in Bronx Park, New York, next Arbor Day. They will be planted in the form of a star with plenty of room to spread and grow. This is to commemorate Alexander Hamilton as well as the veterans of the post. All but two of the thirteen trees originally planted by Hamilton in St. Nicholas Terrace, near 143rd street, New York, have died.

Neglect in their earlier years and want of room have prevented their flourishing.

\* \* \*

A very interesting feature of primary education in Russia, says *Nature*, "is the establishment and rapid development of small farms, orchards and kitchen gardens in connection with many primary schools, especially in the villages. The land for such model gardens or farms on a small scale was mostly obtained through free grants from the village communes, and occasionally from the neighboring landlords, while the expenses are covered by very small money grants from the country and district councils. In the province of Ekaterinoslav, south Russia, almost every school has not only an orchard and kitchen garden for the use of the school-master, but that nearly one-half of the schools in the province have small model kitchen gardens, orchards, tree plantations, or farms, at which gardening, silviculture and sericulture are regularly taught. This province being mostly treeless, special attention is given to tree plantations, and next to silkworm culture. The aggregate area of the 227 school farms or gardens attains 283 acres, and they contained, in 1895, 111,000 fruit trees and 283,300 planted forest trees, nearly 14,000 of the former and 42,000 of the latter having been distributed free among the pupils during the same year. The money grants for these 227 gardens were very small, i. e., a little over \$1600. Besides, over a thousand beehives are kept, partly by the school-master and partly by the children; and some schools had vineyards in connection with them. This movement has widely spread over different provinces of central Russia, where the culture of cereals dominates at the school farms, while in Caucassia attention is specially given to the silkworm culture and the culture of the vine. Something might be learned from the suggestions conveyed in the above.

\* \* \*

The Fairmount park commissioners, Philadelphia, are finding it necessary to issue more stringent rules, in connection with penalties, to prevent injury to the trees, shrubs and ferns by the thoughtless. The beautiful ferns and fall foliage has an irresistible attraction to depredations of this kind, and among the chief offenders appear to be the cyclists, who, to decorate their wheels, pluck and uproot in every direction, regardless of regulations. It is the aggregate of such petty delinquencies that makes the offense a serious one, and necessitates positive action by the authorities. No person will probably be allowed to carry any foliage, ferns or flowers of any kinds, known to grow in the park, within its limits. This would seem arbitrary and offensive, and the commissioners should seek some more equitable deterrent.

\* \* \*

Fall flower shows in prominent parks are becoming quite a feature, and a good one, of park management. Such exhibitions tend not only to keep up an interest in park matters, but affords an opportunity of carrying the usefulness of the park later into the inclement season of our northern latitudes. Then the chrysanthemum is a plant of such beauty and variety, that in itself it is an attraction, and its cultivation in our parks and their greenhouses, readily lends itself to park details and makes a delightful closing of the year's work.

\* \* \*

The new pavilion, Chicago, has been dedicated. The new structure is of stone and pressed brick and is two stories high, the outside walls of the lower floor and foundation being composed principally of granite bowlders. The roof is gabled and constructed of French tiling. One of the architectural features of the building is an arrangement of "four-fold doors" which answer the purpose of walls in the winter. In warm weather they will be removed and the structure thus converted into a pavilion. Rooms have been set apart for skaters, and provision will be made for cyclers.



## CEMETERY NOTES.

No fewer than 1,173 persons have been buried in Westminster, Abbey.

\* \* \*

By the recent action of the Board of Trustees of the village of Hempstead, Long Island, N. Y., the town burial ground, on Fulton Street, of that village is to be converted into a public park.

\* \* \*

Improvement work has been vigorously prosecuted at Forest Hill cemetery, Utica, N. Y., the past season. The conservatory, 40 ft. by 110 ft., has been entirely rebuilt, and the interior of the chapel remodeled, with an enlargement of each of the 144 crypts; a barn, store house and ice house have been completed, and a great improvement of the sewer system carried out.

\* \* \*

A genuine interest has been awakened and a spontaneous determination reached to rescue the old Beckley cemetery at Berlin, Conn., from further decadence, which has gone, as in many other places, far enough. Public meetings have been held and money, labor and materials subscribed to renovate this little "city of the dead," and it is possible that a new association will be formed to take care of its interests to ensure its improvement and future maintenance. Let the good work go on.

\* \* \*

The trustees of Oak Grove cemetery, Delaware, O., after years of effort believe they have finally solved the question of "Perpetual Care," and have brought round the lot-owners to their views. It being an old cemetery the difficulty attaching to older lots is the same as prevails elsewhere—absentees and loss of interest. Since 1894 all lots have been sold under perpetual care, a sum having been set aside from the sales. It is now the permanent work of the Trustees to make Oak Grove a beautiful Memorial Park.

\* \* \*

The financial report of the St. Lawrence and St. Bernard cemetery association, New Haven, Conn., for 1895, showed a continued improvement. The Catholic cemeteries are rapidly realizing the spirit of the times, and improvements on modern lines are progressing. In the above cemetery the total receipts from all sources in 1895 were \$7287.50, which with previous balance on January 1, 1895, made a total of \$11,515.12. The total running expenses for 1895 were \$4329.51, leaving a balance January 1, 1896 of \$7185.61.

\* \* \*

An article in a New York daily draws attention to a new branch of real estate business,—that of cemetery lot agents. The depressed times have forced many lot owners to consider the fact of turning their unused lots into cash, or disposing of parts of them, and besides lot owners moving to other parts of the country find it often convenient to also transfer their cemetery associations. The lot agent hunts up his customers, and as the business has presented many features for development, it may become quite a department of real estate operations, and it requires no mean ability. Of course the cemetery corporations are in radical opposition.

\* \* \*

A large party of well-known Brooklyn and New York citizens paid a visit to Cedar Grove cemetery, between Flushing and Corona, Long Island, recently. The cemetery is situated about 5½ miles from New York, and from its picturesque location upper New York can be seen across the sound. The cemetery comprises between forty and fifty thousand lots and is con-

ducted on modern ideas. No fences are allowed, and granite boundary posts are supplied by the cemetery. Trees and shrubbery abound in beautiful association. In a sequestered part of the cemetery, a grove of fine old locusts protects one of the oldest burials grounds of Long Island, dating back before the Revolutionary War, some stones are still to be seen with their inscriptions. The attendants at funerals are uniformed, a tent is used and details are carried out on the most approved practice. An old mansion has become the superintendent's office and residence.

\* \* \*

The handsome marble memorial belonging to Lieut.-Col. James B. O'Neill in Northwood cemetery, Germantown, Philadelphia, was the object of a vandal's dynamite exploit on the night of November 7, which resulted in damage to the amount of several thousand dollars. The monument was valued at \$20,000, and is mainly constructed of Westerly granite with Carrara marble statuary. The shaft crowning the monument is 29 ft. 7 in. high cut from one block and it was shaken out of plumb, while of the four marble figures adorning the sides, only one escaped injury. These figures were 5 ft. 6 in. high. The medallion portraits were also injured. The cemetery has been suffering from disaffected labor, and changes in foremen for some time, and to this condition of affairs many acts of vandalism in this cemetery are attributed. Indications suggested by current reports point to the question being raised again of the cemetery association's liability for such damage.

\* \* \*

A comprehensive scheme of cemetery work is that of the London Necropolis Co., of London, England, which controls perhaps the largest cemetery in England, consisting of some 500 acres of beautiful country. The cemetery, called "Brookwood," is situated some thirty miles from London, and is reached by trains operated by the company from a private station in the metropolis. An undertaking business, complete in all its details, also forms a part of the enterprise, and on the grounds a monumental establishment is maintained, with facilities for furnishing designs and carrying out such monumental and statuary work as may be required. In fact the company is established to furnish all material necessities, in all grades, as well as conduct the ceremonies attending the final obsequies of departed humanity. The company was organized under an Act of Parliament in 1850. A crematory is also operated and maintained at the cemetery grounds. The grounds are in excellent order and the location is a beautiful one.

\* \* \*

Ground has been broken in Fairmount Cemetery, Newark, N. J., on the circular plot, 150 feet diameter, owned by Judge Gottfried Krueger, for his family mausoleum. The main edifice will be 26 feet square, with two small wings on either side and an apse in the rear. The height from the ground to the emblem, symbolic of eternal life, on the top, will be 46 feet. The four corners of the structure will be surmounted by urns, with torches. The wings will accommodate twenty caskets. The apse will be semi-circular, and will contain two sarcophagi of Tennessee marble, cut from a single piece of stone, hollowed to receive the casket. The covers will also be of single stones. The front is graced by a pure Grecian Ionic portico, with the name and appropriate emblems upon the frieze and gable. The columns rest upon a solid granite platform, with granite steps. The doors will be of heavy bronze. The building will be lighted mainly from the dome and from circular openings in the sides. The lower windows will be protected by heavy bronze railings. The principal material of construction will be high-grade Barre granite. The interior will be finished largely in Italian marble. An aisle will run from front to rear, with side aisles into the wings. Arches



supported by columns carry the dome, and these columns and pilasters will be of Etowah (Ga.) marble. The ceilings of dome and apse will be of artistic mosaic work. Considerable gray and pink Knoxville marble will be used about the crypts and as background to proposed statuary. The floor will be mosaic of Italian marbles. Reached by descending marble steps, there will be a crypt below the main floor and also below the apse, with cells for sixteen more caskets, making thirty-six in all. About the sarcophagi there will be figures of angels in Carrara marble. A highly decorative lamp, always burning, will be suspended under perforated bronze openings in the dome, connected with ventilators. The skeleton part of the dome will be of iron, supported on iron beams, all encased in brick. The pendentives, ceiling and covering of dome, forming the bedding for the granite, will be of Gustavino tile, as used by the Moors when in Spain. The work is to be executed in the best manner possible. Contracts have been let to George Brown & Co., for the granite work; and to Messrs Hunt Bros., for the marble work. The mausoleum will be constructed from designs by Gustavus Staehlin, architect, and will cost some \$90,000, the plot of ground having been secured for \$9,000.

#### Effect of Electric Light on Trees.

In a communication to *Meehan's Monthly* Mr. John Hugh Ross of Montreal details his observations on the apparent effect of the electric light on trees. He says: "In front of my house all the trees that are within 50 or 60 feet of the big arc lights lose their leaves and show many dead branches. One tree within 15 feet of one of these lights is nearly stripped to the lowest branches, and is dry and dead (it is maple). A tall elm about 30 feet away is fast losing the leaves from the long pendent branches and a butternut in front of my window is fast going the same way. To test this point I have taken walks about 20 miles in extent through the city streets with same results visible everywhere, so I am convinced the electric light is hurtful to most trees. They can't sleep with those big glaring electric eyes shining from about 8 p. m. to 3 a. m. or thereabouts. I believe there is also a chemical action from these lights. The tree cannot live in almost eternal day—they, like human or animal life of any kind, *want rest*. It is only near these lights the decay is so marked. Have any of your correspondents noticed this? I would like to know. Maples, butternuts and elms seem to suffer most. Willows or horse chestnuts do not seem to be affected—nor the lilacs—the cotton wood does not seem to feel it at all.

Montreal is the best lighted city I have seen on this continent, not excluding New York. The lights are large arc ones and placed about 25 to 30 feet from the ground. Now note this: The trees all begin to lose their leaves on top or on the side facing the lights, and gradually keep losing them downward." This is an important matter which observations in other localities will help to elucidate.

#### Legal.

##### RIGHT OF ACCESS TO CEMETERY LOT.

The court of appeals of New York has rendered an important decision, in principle, in the case of *Palmer v. Palmer*, where it reverses the decision of the general term of the supreme court of that state. The purpose of this action was to establish the plaintiff's right to a way across the defendant's farm, from a certain street of the town of Mamaroneck, in Westchester County, to a private cemetery owned by her in the rear of the defendant's premises, and to enjoin him from interfering with the exercise of that right. The defendant and plaintiff were brother and sister. In the settlement of their father's estate, by the heirs, the farm mentioned was deeded to the defendant, and the cemetery lot to the plaintiff and her sister. After the deeds between the parties to that transaction were executed and delivered, the plaintiff and her sister had no interest in any land bordering upon that conveyed to them, and it did not adjoin any street or highway. Under these circumstances, the court of appeals holds that the plaintiff and her sister obviously acquired a right of way by necessity from and to their cemetery lot over the remaining part of the farm. The law on the subject it says is that where a person conveys to another a piece of land surrounded by lands of the grantor, the grantee and those claiming under him have a right of way by necessity through the lands of the grantor, as an incident of the grant. And this principle applies where the land conveyed is surrounded in part by the lands of the grantor, and in part by the lands of a third person. The grantor in such a case has the right to designate the track or way, having due regard to the rights of both parties; but, if he declines or omits to exercise that right, the grantee may select for himself, and will be supported in his selection unless chargeable with palpable abuse. A right of way of necessity over the lands of a grantor, in favor of a grantee and those subsequently claiming under him, is not, however, a perpetual right of way, but continues only so long as the necessity exists. In this case the grantor was not shown to have designated the track or way to be used by the plaintiff, but she continued to use the way as it formerly existed, and was previously used by the family in passing over the farm to the cemetery. Thus, the court says she selected the old way, which must be regarded as established and consented to by the parties, as no objection seemed to have been made for years after the selection or during the continuance of its use. The doctrine here laid down, it will be seen has a wide application.



### Association of American Cemetery Superintendents.

G. W. CREESY, "Harmony Grove,"  
Salem, Mass., President.  
ARTHUR W. HOBERT, "Lakewood,"  
Minneapolis, Minn., Vice-President.  
F. EURICH, Woodlawn, Toledo, O.,  
Secretary and Treasurer.

### Publisher's Department.

Park Commissioners and Cemetery trustees are requested to send us copies of their reports.

Photographs and descriptive sketches of interesting features in parks and cemeteries are solicited from our readers.

Mr. R. Ulrich, who has had considerable practice as a park superintendent East and West, has formed a partnership with Chas. W. Leavitt, Jr., under the title of Ulrich & Leavitt, Landscape Architects and Civil Engineers, located at 15 Cortlandt street, New York.

P. S. Peterson, the Chicago nurseryman, has been awarded by the Lincoln Park Commissioners the contract for setting out the trees required on the extension of the Lake Shore Drive, Chicago. Mr. Peterson has furnished a large number of trees for Lincoln Park.

Notwithstanding the general depression in business more parks and cemeteries have been laid out and are being developed than ever before. There is abundant evidence that park and cemetery superintendents have greater purchasing power through appropriations or funds on hand than any other similar class. The laying out and developing of public grounds require labor and supplies of various kinds, among which may be mentioned: Steam road rollers, cement, asphalt and implements used in road making; agricultural implements (such as plows, harrows, rollers, seeds, lawn mowers and other things required in making or keeping lawns); nursery stock, plants, flowers and seeds; fencing of every description, monuments, statuary, etc. The result of the election will loosen the purse strings of capitalists and there will no doubt be a boom in public work of every description. If you desire to sell any of the supplies used—or which ought to be used in parks, cemeteries or public grounds—it will pay you to advertise in PARK AND CEMETERY.

RECEIVED.

Descriptive pamphlet of the London Necropolis Company, London, England, and its cemetery of "Brookwood" at Woking. Illustrations, price lists and other details.

Transactions of the Cremation Society of England, No 9—Lecture on Cremation at Ventnor, I. W., by Rev. R. Ussher, St. Albans.—On recent proposals relating to Burial and Cremation, and the importance of Disinfecting all bodies dying from Infectious Disease; etc., etc., by Sir Henry Thompson, F. R. C. S., M. B.

Descriptive pamphlet of Cedar Grove Cemetery, near Corona, L. I., with Rules and Regulations, Prices, etc. Illustrated with half tones.

Manual of St. Francis' Orphan Asylum Corporation and St. Lawrence and St. Bernard Cemetery Association, New Haven, Conn.

Year book of the United States Department of Agriculture, 1895.

St. Agnes Cemetery, Albany, N. Y., Charter, Rules and Regulations; Catalogue of Lot Owners, etc., revised to June 1, 1896.

#### FAMILIAR TREES AND THEIR LEAVES.

By F. Schuyler Mathews. New York, D. Appleton, 1896.

The wealth of interesting study in tree life is scarcely appreciated, even in this day of educational privileges. The function of trees, their variety, their individual characteristics are matters so intimately connected with our every day life that some knowledge of them would certainly be beneficial on general principles, and on the other hand would be very useful information in many directions. Mr. F. Schuyler Mathews' writings on plant life are well known and appreciated, and in his work now issued he has provided us with a fund of information in a convenient arrangement of details, which affords interesting reading to the dilettante lover of trees and valuable matter to those needing it for more applied study. The book is illustrated with over two hundred drawings by the author, all sketched from nature. The list of trees described number over two hundred and may be classed as familiar, but of which most of us will acknowledge to have known very little before perusing Mr. Mathews' book. It is written on a plan which is carried through, classifying the leaves and illustrating them and describing the trees bearing such leaves under the classification. We fully endorse Prof. L. H. Bailey's remarks in his introduction to this book: "I am glad of every new book, therefore, which invites people to see and know Nature. That method of treatment is best which interests the greatest number of persons. \* \* \* As foliage is the most obvious feature of trees, aside from form, it would seem that leaf forms afford the most useful basis of introduction to a common knowledge of trees; and if, in addition, the

artist draws and describes them as he sees them the result must be beneficent."

THE NEW HORTICULTURE. By H. M. Stringfellow, Galveston, Texas. Published by the author.

To anybody interested in the practical experiences of an enthusiastic horticulturist who, by dint of close application to the work in hand and persistent study of its requirements, made a financial success of the cultivation of a few acres of unpromising land on Galveston Island, Texas, many years ago as a beginner, *The New Horticulture* will be taken up with pleasure and not relinquished until the end. To others to whom a description and discussion of radical methods in horticulture are attractive the book will afford a field for thought and possible suggestion. The work of the author has been confined, however, to the south, where conditions are different from what we generally experience further north, which, perhaps, must be given credit in following the author's experiences. Unquestionably the book is written in an entertaining manner, and while many will differ and doubt upon the efficacy of much of the author's methods and practice, there is a large amount of clear and comprehensive experience graphically described, from which deductions may be drawn and possible help derived for the reader's benefit.

THE GARDEN, as Considered in Literature by Certain Polite Writers, with a critical essay by Walter Howe. New York and London, G. P. Putnam's Sons.

The firm of G. P. Putnam's Sons has been issuing a series of classics, so to speak, under the title of Knickerbocker Nuggets, among which *The Garden* is a gem. These booklets, from the bookmaker's standpoint, are equally worthy of high commendation. The title of the little work describes it, and we who are interested cannot but take delight in the perusal and study of the budget of literary effusions so daintily set before us. Within its covers we can walk with the Plinys in their Roman villas and gardens, learn the views of Lord Bacon, Sir William Temple, Addison, Alexander Pope, Lady Mary Wortley Montague, Thomas Whately and Oliver Goldsmith. We can become acquainted with William Kent, the "father of modern gardening," from the eloquent pen of Horace Walpole, and get John Evelyn's descriptions of Fences and Quicksets. Here is a literary feast on the fascinating subject of the garden—a handy little work to take up and set down as often as one wishes, but on each occasion sure of yielding a refining influence or a mental stimulus of a greater or less degree.



# PARK AND CEMETERY.

FORMERLY THE MODERN CEMETERY.

A Monthly Journal Devoted to Parks and Cemeteries.

R. J. HAIGHT, Publisher,  
334 Dearborn Street, CHICAGO.

Subscription \$1.00 a Year in Advance. Foreign Subscription \$1.50

VOL. VI. CHICAGO, DECEMBER, 1896. No. 10.

## CONTENTS.

EDITORIAL.....	379
*CAVE HILL CEMETERY, LOUISVILLE, KY.....	380
TWENTIETH CENTURY GARDENING .....	384
*THE ST. WINIFRED FOUNTAIN, HUDSON, N. Y.....	385
*GARDEN PLANTS, THEIR GEOGRAPHY, XIV.....	386
*NATIONAL CEMETERY AT CHATTANOOGA .....	388
*AN ENGLISH HOUSE IN PHILADELPHIA.....	390
HARDY WOODY VINES IN LANDSCAPING .....	391
NOTES .....	392
PARK NOTES.....	393
CEMETERY NOTES.....	394
CREMATION.....	395
PUBLISHERS DEPARTMENT.....	396

\*Illustrated.

THE Methodist Minister's Association of Baltimore, recently issued an address to the public, in which the objections to the Sunday funeral were plainly stated, and a plea urged to remove such objectionable features of the burial ceremony as have proved themselves baneful and not in accordance with present spirit of the Christian world. It is gratifying to note the growing sentiment in favor of reducing to a minimum Sunday burials, as well as to modify the services about the grave. Moreover, the fact that the clergy are, both individually and collectively, falling into line on this important question augurs well for more rapid reform in these particulars. It is unnecessary to enumerate the many valid reasons for a change in the old fashioned ideas regarding funerals and funeral cus-

oms; they have frequently been referred to in these columns; they are the evolution of the ages, and to effect change in so well established ceremonials and customs requires an active educational influence. This the cemetery officials in conjunction with the clergy are in position to impart, and the beneficial reform to be secured is worthy of persistently active effort.

INQUIRIES often come from remote places asking for information that should readily be obtained nearer home, and, if regarding subjects of local interest, of course should be found in the nearest public library. That this is not so in so many cases may be primarily ascribed to two causes: lack of appreciation on the part of the library authorities of the importance of maintaining a section devoted to local information, and lack of consideration on the part of citizens specially interested in certain local matters in not keeping the library supplied with such matter as comes within their disposal. Referring the question to material pertaining to parks and cemeteries: the public library should keep up with the times and provide itself with certain authentic works of reference, as well as the best current periodicals on this line of public improvement so that the community might be helped to intelligently take a hand in any discussion that might arise. And on the part of the community, any member engaged in park and cemetery work, should make it a special point to see that the library is furnished with all the printed matter and other available information he may be able to supply. We are in the era of cemetery and park development on a high plane, to the proper progress of which all available information ought to be accessible, and the public library should be able to offer the community the best current information on such work. In the larger towns the library officials should appropriate funds for the purpose: in the smaller places consideration for the public welfare should inspire the collection and care of such material, to be made available wherever convenient and accessible.





THE BOWLES MONUMENT.

Cave Hill Cemetery,  
Louisville, Ky.

**I**N 1848, the City of Louisville deeded to six Trustees 47 acres of land, part of a tract known as Cave Hill Farm, for perpetual use as a Cemetery. It was laid out by Benj. Grove, and dedicated July 25, of the same year. The grounds now comprise 260 acres, 300 acres being the limit under the present charter.

\* \* \*

Cave Hill is fortunate in many respects, but pre-eminently in topographical beauty and in its firm financial basis. Its perpetuity is secured by a fund created by reserving a proportion of the proceeds of the sale of lots until the sum of \$200,000 was reached. This fund is managed by the Cave Hill Investment Co. chartered in 1882. It was held and the income (except that part used for the necessary expenses of the company) re-invested until the par value of the fund equalled \$200,000. Since then the income has been paid over to the Cemetery managers and used in keeping up and improving the grounds.

\* \* \*

Many improvements have already been made, all of the most substantial character. Chief among them are the two office buildings.

That of the secretary and treasurer is at the entrance. It is of stone and the belfry is surmounted by a copy of Thorwaldsen's Angel of the Resurrection. A copy of the same sculptor's statue of Christ occupies a niche above the entrance. The building contains pleasant office and committee rooms with open fireplaces, and a spacious fire proof vault.

The following description of the superintendent's office is by Mr. Campbell, who is justly proud of his handsome quarters: "Just beyond the lake is the superintendents new office. It is one of the most complete and ornate buildings of its kind in the United States. It is of Bedford stone throughout and fire proof. The floor of the circular veranda is of stone and the seats of birch with mahogany trimmings. The veranda roof is supported by twelve stone pillars between which are circular arches covered by various climbing plants and the whole enclosed by an open iron railing. The building is

fitted with every convenience for the transaction of the Cemetery business. A private telephone system connects it with all parts of the grounds and a city telephone with the city. A 1,500 lb. electric signal bell in the tower calls the various officials and workmen. On the main floor are the waiting and toilet rooms, the superintendent's private office, and a handsome fire and burglar proof vault. The floors of the waiting rooms and offices are of polished oak. The open fire places are of tile in French pink, blue, etc. Above the birch mantel in the Ladies' waiting room is a beautiful stained glass window. The walls are finished in Acme plaster and are terra cotta in color. The ceilings are of steel plates of fancy designs painted cream color. In the attic and basement are well arranged tool and store rooms. The *porte cochere* has a granitoid pavement. The cost of the building was \$18,000."

Near the middle of the grounds is a pretty little rustic shelter house; and perfectly appointed modern brick stables complete the architectural features of this class.

\* \*

There are more than six miles of thoroughly well made macadamized roads and more than ten miles of grass walks already made; 1,515 ft. of  $\frac{3}{4}$  inch, 5,724 ft. of 3 inch, and 5,249 ft. of 4 inch water pipe laid with 46 hand or self closing hydrants 6 wagon hydrants and 13 hose boxes. Hose can also be attached to the self closing hydrants. Work done during the



OFFICE OF SECRETARY AND TREASURER.

past year, besides road making and pipe laying included in above figures, comprises one mile 1,890 feet of 6 to 15 inch sewer pipe laid, 35 catch basins built, 1512 perch of rock quarried, 530 yards of gravel used in repairing roads, and 138 lots averaging 470 square feet each prepared for sale.

Total number of inter-



ments to June 1, 1896, 29,083. There are no greenhouses, but a nursery of young trees and shrubs is maintained, and plants throughout the grounds are labeled.

The company owns and operates a line of wag-  
onettes inside the grounds. They are run every  
day in the year at intervals of from 30 minutes to  
one hour, the round trip costing 10 cents. This  
convenience is so greatly  
appreciated by lot owners  
and visitors that other cem-  
eteries might well profit by  
the example.

To keep up all this work  
an average of 70 men are  
employed.

\* \* \*

Mr. J. G. A. Boyd, the  
able and courteous Secre-  
ary and Treasurer, has  
originated what is probably  
the most elaborate system  
of records yet devised. By

ted and the use of foot stones is discouraged, but  
mounds from four to six inches high are required  
(but may be leveled where graves are marked by  
head stones), and there are no restrictions regard-  
ing monuments to the end of securing only those of  
artistic merit, although the management reserves  
the right to remove any that in their judgment are  
inappropriate. Monuments must face on the ave-



FOOT OF LAKE.

nue or alley on which the lot  
fronts, and head stones must be  
at least six inches thick.

\* \* \*

The average size of sections is  
seven acres, and eighteen are now  
in use. The largest have an area  
of 2,500 square feet.

There are three single grave  
sections. Two, of 1,500 and  
3,500 graves respectively, are  
filled; the third, with a capacity  
of 5,000 graves, is now in use.

Head stones in these sections must not exceed two  
feet in width nor three in height, including base,  
for adults, nor more than eighteen inches in height  
for children. Foot stones are not allowed.

\* \* \*

The receiving tomb with a capacity of 80, and chap-  
el annex, with seating capacity of 100, cost \$20,340.

\* \* \*

There are many elaborate monuments and



LAWN AND BORDER SCREEN OF TREES.

it graves are located by exact measurement and re-  
duced to scale so they can easily be located on  
level lots and without markers. The plan seems  
so admirable that it is not likely to be improved  
on, but it is too complicated and expensive for  
general use.

\* \* \*

The lawn plan is not strictly enforced in this  
cemetery. Enclosures around lots are not permit-



memorials, representing a large investment, some of which are interesting in themselves aside from their size and costliness.

Among the better known names of those who rest here are Jennie Cassiday, the invalid philanthropist who from her bed organized and directed numerous beneficent charities, most of which bear her name. The monument to her memory was erected by penny contributions from school children. Also Gen. Geo. Rogers Clark, who perhaps stands next to Daniel Boone in the esteem of Kentuckians; James Guthrie, once Secretary of the Treasury; James Speed, Lincoln's Attorney General; George D. Prentice; Mrs. Amelia Welby, the poetess; Alexander Drake, the actor; Judge Bland Ballard, Gen. Wm. Preston, Bishop Kavanaugh, and the descendants of the poet Keats.

\* \* \*

Nearly 5000 Federal and about 600 confederate soldiers are buried here, most of whom died in the Louisville hospitals. A rose is planted at the grave of every one that wore the gray. Opposite the hill side where the Union soldiers sleep rises another, belonging to the places reserved for decorative planting, which is clothed with what looks like an indigenous growth of young trees. In the narrow valley between nestles the finest, as well as the most charmingly natural looking Lotus bed I have ever seen. The entire effect of hill-side and pond is naturalesque and delightful.

\* \* \*

Cave Hill lies 510 feet above the sea and 105 feet above the level of the Ohio, river, and is topographically beautiful. Hills, some easy others quite abrupt, alternate with valleys and table lands, and distributed singly or in groups, are numerous saucer-like depressions, characteristic of this region, that have been poetically and aptly called "dimples on the cheek of nature," all of which are reserved for planting. The whole is underlaid with limestone which has to be quarried to a depth of six feet in the preparation of all

lots save a few on the highest elevations.

\* \* \*

That part of the older ground looks strangely bleak, and bare of trees of good size and shape, is partly due to the misfortune of war, for at some time during the trying years of 61-65 soldiers encamped in the cemetery and practically cut out every large tree except the Honey Locusts, and their immunity is not far to seek—they were securely intrenched within the barrier of their own fierce bayonets. The too trim, even severe appearance is still more due to the planting of almost no trees except Box and Holly, and to clipping these into

formal shapes that make them nearly as hard in outline as the stone work they should veil and soften. The artificial aspect is further heightened by the use of curbing along all avenues and alleys in this locality. As the sharp hill sides bristle with monuments and stones from

foot to crest it can readily be realized that the effect is extremely architectural, and the addition of many stiff carpet beds carries out the rigid scheme to the

fullest degree. Without doubt it is a perfect example of this type of cemetery work, but it is a type that Landscape Art does not sanction.

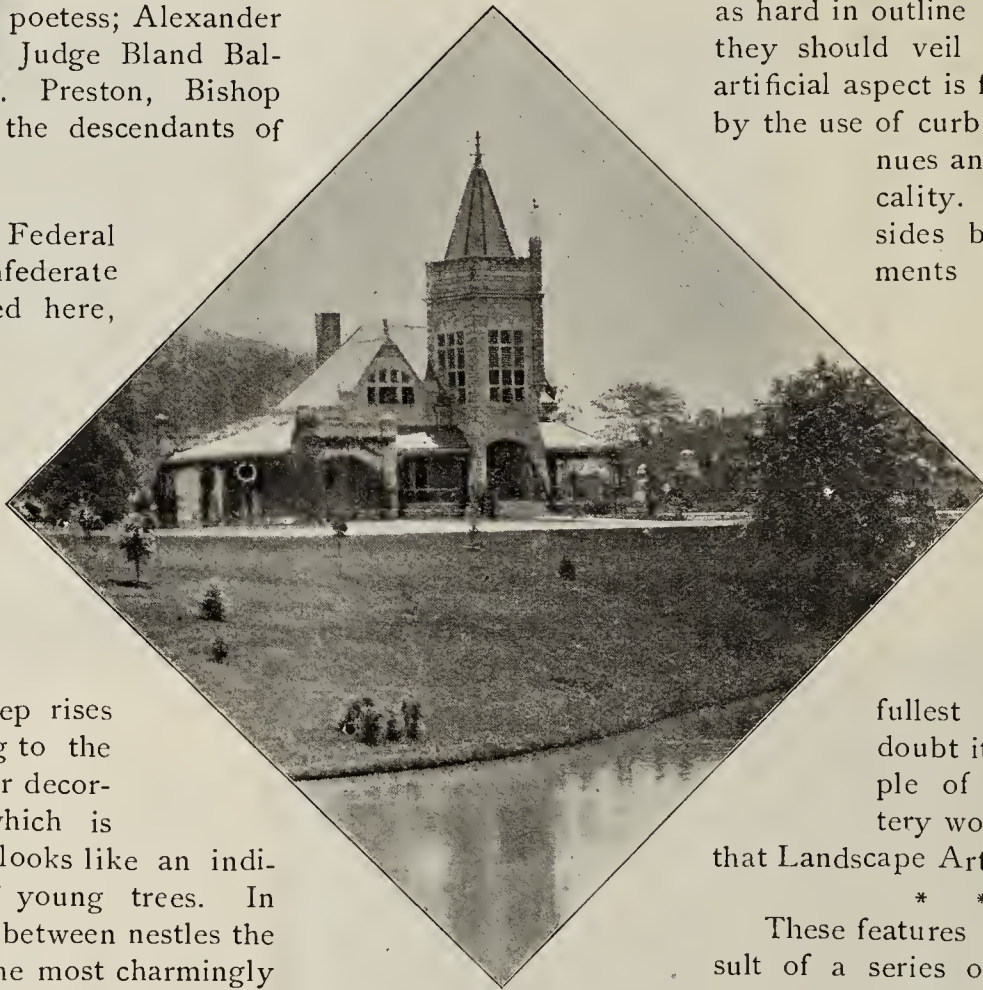
\* \* \*

These features seem to be the result of a series of unfortunate compromises forced on the management by circumstances.

The genial President of the board, Mr. J. H. M. Morris, explained that curbing was introduced because it seemed a lesser evil than the fences that lot owners wished to use as boundaries, and that not only is no more to be put down, but the management hopes eventually to remove all that is now in place.

Again, Mr. Campbell, the bright and energetic superintendent, says regarding the unyielding outlines of the trimmed trees that "every body wants a tree and there would not be room for so many were they not kept clipped."

One feels sure, however, that the higher type of art seen in other parts of the cemetery must in time



SUPERINTENDENTS OFFICE.



convince all that the full development of the characteristic landscape beauty of their favored state is better than anything foreign or artificial. It is pleasant to know that these features do not find



RUSTIC SHELTER HOUSE AND WAGONETTE.

favor with the officials in charge and that they hope to do away with them.

\* \* \*

Among the few native trees spared are a fine Tupelo and a grand old Beech four feet in diameter. But there are hundreds of splendid specimens among those that have been planted. A few of the less common are the Laurel and Willow leaved and Fastigiata Oak, Lawson's, Chinese, and Southern Cypress; Persimmon and Pawpaw; Siberian, Eagle's Claw and Purple Norway Maple; Fern leaved, Purple and Copper Beech (an extra good one of the latter); immense Osage Oranges, Snowdrop tree (lovely when in flower), Scarlet Thorn and Paulownia Imperialis; Kentucky Coffee tree, Yellow Wood and Kolreuteria Janiculata; a number of Conifers, but the Hemlock Spruce seems the only one likely to survive the smoke of the encroaching city; and far and away the best Japanese Ginkgo tree I have yet seen. It towers above the pretty little rustic shelter to a height of sixty feet, has a spread of thirty feet, is thirty-five years old and in late October was a symmetrical mass of exquisite, pale gold-colored foliage. But, after all, the Magnolias are the chief arboreal attraction. They are there in variety, from the starry flowered *M. Stellata* to the matchless cups of *M. Grandiflora*, and while I saw no very large specimens of the latter, their abundance compensates for lack of individual stature. One of the natural depressions mentioned is to be wholly occupied by a group of one hundred of them. A sight of that group when in flower will alone be worth a visit to Cave Hill.

\* \* \*

I think that all shrubs common in more northern gardens is represented here besides a number of others, such as California Privet, which grows to

perfection; *Xanthoceras Sorbifolia*, with flower spikes twelve to eighteen inches long; *Exchordia Grandiflora*, bearing pure white, fragrant flowers in early spring; *Olea Americana*, which bears purple fruits shaped like a very small olive. It is a shrub of the highest decorative value, handsome both in form and foliage, but the superintendent finds it very scarce and is unable to get as much of it as he wants. *Phyllodendron Amurence*, which is hardy, but fails to bloom; *Rhodotypos Kerrioides*, *Ligustrum Ibotia*, *Dimorphanthus Mandshurica*, bearing white flowers in May, followed by berries in large compound panicles that are blue black when ripe; and above all, Roses.

Magnolia blooms are magnificent, but comparatively short lived, while everblooming Roses are in flower from May until frost. Varieties like *Hermosa*, *Agrippina*, *Gen. Jack*, *La France*, *Souv. de la Malmaison*, *Sombreuil*, *Perle des Jardins*, *Duchesse de Brabant*, *Magna Charta*, *Etoile de Lyon*, *Safrano* and *Giant of Battles* survive in good shape with a light mulch of hay as a winter protection. By virtue of their beauty, number and abundant and persistent bloom they are the chief floral feature of the grounds.

\* \* \*

Vines are given prominence, notably on the pillars of the porches surrounding the ideally situated office of the superintendent, to which they are an added charm. They include *Wisteria*, *Ampelopsis*, *Akebia*, *Honeysuckles*, *Jessamines*, *Euonymus*, *Passiflora*, *Berchemia volubilis*, a half dozen or more varieties of the most desirable *Clematises*, and *Bignonia capreolata*, which makes a golden frieze of flowers in spring and of foliage nearly all the rest of the year.

English Ivy clothes the trunks of numbers of trees, and climbers in variety drape a cliff where the exposed limestone foundation of the hills is appropriately utilized as the basis for a picturesque bit of landscape work. Naturalesque treatment of the foreground would, however, make this feature far more expressive than the present arrangement of closely shaven level lawn and beds of semi-tropical plants.

\* \* \*

Herbaceous plants are pleasingly introduced, indeed nothing could be more charming than the dear little dells carpeted with Violets and Ferns that, after their own shy fashion, creep in and out through the half shade of shrubs and trees. Probably these spots were cunningly contrived to unsettle the faith of those who put their trust in rigidly artificial styles of gardening, and certainly they are well devised to accomplish that end.



The cemetery is rich in aquatics—in fact, hardy Nymphæas are a fad with Mr. Campbell, and the character of the grounds is well suited to its full development.

There are five lakes. The principal one, with an area of 108,160 square feet, is fed by several springs, the largest being in the cave that gives the cemetery its distinctive name. Of the five smaller ones, having an aggregate area of 28,650 square feet, three are fed by springs and the other two by the city reservoir. Two of them are planted with Nelumbiums in variety and one with hardy Water Lilies. With the favorable conditions offered it would seem that Cave Hill might show the finest field of Japan Irises in this country.

\* \* \*

Scrupulous care and nicety is shown in every department of the work and exquisite neatness prevails throughout the grounds. And enthusiasm, energy and progressiveness are such strongly marked characteristics of all branches of the management that Cave Hill is certain to show new beauties and excellencies in future that will be well worth watching and waiting for. *Fanny Copley Seavey.*

#### Twentieth Century Gardening.

The suggestion made in your November leader is, of course, a rational one, and as you show in various other items (pp. 371-373) has for hundreds of years been adopted in the older civilized countries. There is but little doubt in my mind, however, that this very fact militates against the suggestion, for it cannot be denied that the gardens and parks hitherto formed for educational purposes have rarely, if ever, been in harmony with the idea of the landscape gardener. The scientists who often control them think of little but a vain endeavor to crowd the greatest number of plants on the space at their disposal, and this is always destructive of harmonious composition. It is a vain and unnecessary endeavor. No single climate in the world can collect more than 3,000 species (with varieties) of real value to the landscape. To add more is detrimental to beauty and destructive to harmony. It results in weediness of aspect and the crowded spottiness common to the largest and best of foreign gardens.

Scientific weed gardens should be out of sight. It is possible, with a suitable system as a basis, to plant parks and gardens and cemeteries so that they may compass all the real beauty of a local garden flora, but the selection of material must be rigid and the knowledge profound, or the heterogeneous disposition may excel it in beauty, even though it convey nothing of orderly instruction. In a word, the superficial practitioner cannot successfully attempt it.

It is probably a fact also that the greater number of Americans despise the science of plants in their hearts. It is the same in all naturally wooded countries. Gardening always claims its greatest votaries in the severer climates, where the effort of production is imperative—Scotland, Switzerland and North Germany for instance. Neither can the merit of the composition be measured by its reflection of surrounding nature. Gardening is rather the exclusion of nature with the fences out of sight and the barriers imperceptible, so that none but the knowing can recognize it by the disposition.

Now, nature always mixes her materials in the fertile portions of the globe. In the sterile regions they are more rigidly assorted; the scientists and the gardeners have conspired together to rigidly assort in the gardens, and the result has often been intense artificiality among the trees, insipidity in the shrubbery and chronic disorder in the herb borders.

The great masters of grouping overcame this largely during the last century. Flemming and Ingram in the herbaceous garden, Gibson particularly in the sub-tropical garden, and Eyles and many another in the exotic parterre.

It is a fact to-day, I believe (*I shall be very glad to hear that I am mistaken*), that no one has addressed himself to the harmonious composition of the trees and shrubs and herbs of a botanic garden, with a view to embellishing the ground!

It is only now possible. Such gardens hitherto have been formed by slow degrees. To-day a most respectable collection can be delivered anywhere in a month for \$2,000 or \$3,000.

Moreover, there has been no systems before the later methods of De Candolle and Bentham and Hooker well adapted to the ground, and with extraordinary perversity scientists (for reasons already given) do much to frustrate them.

Fine gardens and beautiful depend for their elegance upon what they exclude. Weeds, rubbish, politicians, cow-gardeners, hide-bound scientists, pseudo-architects, road contractors and jobbing nurserymen cannot be expected to give expression to gardens worthy of the twentieth century.

Trenton, N. J.

*James MacPherson.*

#### A Correction.

Mrs. Seavey begs to correct a mis-statement in her description of the Lexington, Kentucky, Cemetery, in our last issue. The original plat was laid out by Mr. C. S. Bell, the superintendent, and not by the French engineer De La Pradlie, who was only employed to copy and prepare a set of sectional maps for binding.



**The St. Winifred Fountain, Hudson, N. Y.**

The beautiful gift of the statue of St. Winifred to the City of Hudson, N. Y., by General J. Watts de Peyster, was formerly unveiled early last month. General de Peyster is evidently bent on attaining further fame,—to also live in the “hearts of his countrymen,” by his many splendid beneficences to serve his fellowmen or adorn their abiding places. The statue of St. Winifred was modeled by Mr. Geo. E. Bissell of Poughkeepsie, N. Y., and portrays the saint sword in hand, standing on a pedestal of rough hewn and naturally grouped stones, the center piece of a pool and fountain located on Promenade Hill.

of Miracles and Legends, gives as the legend of St. Winifred that she was of high rank and loveliness, and that she was beheaded by Caradoc, the son of Alan, king of North Wales, for refusing to marry him; and that where her head fell a fountain, from the tears which she shed, sprang forth from the ground; and that that fountain was thereafter called Winifred's Well, or the Holy Well; and that the waters flowing from that well possessed miraculous properties. It is also further stated by Dr. Brewer as part of the legend that St. Beno, her spiritual instructor, after she had been beheaded by Caradoc, adroitly set her head on again, and that she re-



THE ST. WINIFRED FOUNTAIN, HUDSON, N. Y.—GEO. E. BISSELL, SC.

It was cast in bronze in France under Mr. Bissell's personal supervision and attention to avoid mishaps and secure good work.

The occasion of the unveiling was quite an event, the circumstances attending the gift promoting general interest. The Hon. C. P. Collier, on behalf of General de Peyster, made the presentation speech, in the course of which he gave the following particulars regarding St. Winifred: “Chambers' Encyclopedia informs us that St. Winifred was a saint of the ancient British Church, and held in great veneration in Wales; that her name is notable in connection with a well-known well, to the traditional miraculous virtues of which the City of Holy Well in Wales, situated near this well, owes its origin and celebrity.

“Dr. Brewer of Cambridge, England, in his book

turned to her home safe and sound.

“All accounts of St. Winifred are legendary. None of the accounts that I have seen state when or where, or why she was made a saint, nor when or where she died; but that she was a saint held in great veneration is stated as I have said.

“As no legend that I have seen gives any account of the reason for placing her in the calendar of saints we may suppose that for good reasons she was made the tutelary saint of this healing well, and that the sword in her hand was placed there to defend it; or she may have smitten the rock from which the healing waters flow, and for that reason was made a saint; or because that where her head fell as stated by Dr. Brewer, this medicinal spring, now called Holy Well, burst forth from the rocks a lasting supply of remedies for human ills.”



## Garden Plants, their Geography, XIV.

## SAPINDALES.

## THE SAPINDUS, ÆSCULUS AND RHUS ALLIANCE.

This is a large alliance of trees, shrubs, climbers, and more rarely herbs, largely tropical, but well represented in temperate regions. Several of our finest flowering and foliage trees and shrubs are included within it. I shall mention but few of the tropical species. There are 24 tribes, 195 genera, and 1550 species in the alliance and many of them are beautiful greenhouse and sub-tropical garden plants.

*Sapindus*, "soap berry" has 10 species in the tropics and sub-tropics of Asia and America. We have one species, *S. marginatus*, found from Kansas through the South, and in Mexico. In the latter country it is a large tree, but in Georgia, etc., it is smaller, with pinnate leaves, racemes of whitish flowers, and globose yellow fruit. The genus is the foundation of the alliance.

*Kolreuteria* has 2 species, both Chinese. *K. paniculata* is well-known in gardens, it is an elegant small tree with yellowish flowers, which appear towards the end of summer. *K. bipinnata*, with brighter flowers, is less common.

*Stocksia* has 1 species, a native of Beluchistan.

*Xanthoceras* has but 1 species, a beautiful flowering small tree or shrub introduced to American gardens about 1873. It does not appear to succeed very well at Washington where I first saw it. At Philadelphia it is a shrub. At Wilburtha, New Jersey, there is the largest and tallest plant known to me in the country. It measured 11 ft. 5 in. in height in 1895. It is the property of W. P. Perry, Esq., and was obtained by him from Washington. It flowers beautifully, but does not perfect seeds. Further north on Long Island there are six feet plants

which perfect good crops nearly every year.

*Æsculus* has 14 species of trees and shrubs from North America, North India, Persia, and China. The American kinds are trees and shrubs, the trees with dull red, pink, or yellow flowers, and the shrubs (often called *Pavia*) with white, pink, or dark red flowers. It is a little strange that these pink flowered dwarfs are so seldom seen in gardens. The Asiatic Horse chestnut is a finer tree and more familiar than the American ones. It varies a good deal, even in the ordinary type, and there are double flowered forms both in white and red. The beautiful little tree known as *Æ.*, *rubicunda* in several varieties, differing in the intensity of their color, has been referred in name at least to *Æ. glabra*, an American form, and to *Æ. hippo-castanum* an Asiatic form. It seems strange that a full series of specimens should fail to determine this variety. I suppose there is no doubt about the *double red* form of the Asiatic species? The finest specimens I have seen considered as to height alone, were examples of *Æ. rubicunda* then known as *R. carnea*, in the old Capitol grounds at Washington—since improved.



KOLREUTERIA PANICULATA.



*Æsucus Indica* is still very rare in gardens and I have not (so far as I know) yet seen it in America. It will very likely be hardier at southern points than in Britain. Its flowers vary a good deal, and I think it likely to include the carnea forms. It has spineless fruit. There are half a dozen species natives of North America, most of which vary more or less; all are found south-east and west of Ohio.

*Acer*, "Maple" includes 84 species of (very variable) trees and shrubs natives of Europe, Northern Asia, North America, the Himalayas, and Java. The Asiatic forms are the most beautiful, while the American forms of which there are nine or ten are perhaps the most majestic. The Japanese *A. palmatum* in its wonderful varieties such as *P. aureum*, *P. atropurpureum*, *P. dissectum*, etc., are the most beautiful small trees or shrubs in the genus. *A. Tartaricum* from the Caucasus and S. E. Europe



STAPHYLEA COLCHICA.

is also a beautiful small tree, some of its varieties being remarkably gay in the autumn. I believe however that the American *A. rubrum* (so-called from its red flowers) is the most beautifully autumn colored tree in existence—when it is colored!—which is much more rarely than may commonly be thought.

My observation leads me to doubt if one tree in 5,000 colors in a manner to attract attention, but when it does do its best it is undoubtedly one of the most striking objects in the vegetable Kingdom, and more enduring in its display than that marvel of the East Indian Forests—the *Butea*. I don't believe I can possibly write a greater sarcasm upon the boasted enterprise of American Nurserymen, than a reference to the *occasional* coloring of this



ACER MACROPHYLLUM.

tree! *A. saccharinum* which certain Botanists wish to call *A. dasycarpum* which also other Botanists wish to call *saccharum*! are the familiar sugar and silver maples. It may be worth mentioning for the South (as the Northern forms are miffy there) that Chapman and others quote a variety of the sugar maple, *A. S. Floridarum*, as being widely diffused.

Some 30 or 40 species and varieties of maple are kept in good nurseries. There are but two species credited to Great Britain, *A. campestre* a small tree or hedge-row shrub, and *A. pseudo-platanus*, which many contend is not a native of Great Britain at all, but adventive from Central Europe and Western Asia. It will certainly grow up from seed in Britain, and as it is not very long lived, I don't see how these Botanical authors reach their conclusions, seeing there is scarcely such a thing in the island as a forest of nature's planting. It varies a great deal both in the coloring of the foliage, and of the seed "keys." *A. macrophyllum* is credited to the whole length of our Pacific coast—from Alaska to Mexico.

*Negundo*, "Ash leaved maple" has 3 species one common to most of the middle states, one Californian and one Japanese. There is a beautiful form



with white variegation which unfortunately will not endure the intense evaporation in the States, but is one of the most striking garden forms in Britain.

*Greyia Sutherlandii* is a tender South African shrub in but one species. I mention it here because it is too beautiful in its flowers to be forgotten, let it flower whenever it will. I have seen but one plant of it in America—with the late John Feast, of Baltimore. It should be tried in California.

*Staphylea* has 4 species, American, European, Japanese, and Himalayan. They are called "bladder nuts" and are rather pretty white flowered deciduous shrubs. *S. pinnata* the European form is a good forcing plant.

*Euscaphis* has two species both Japanese.

*Turpinia*, has 8 species mostly tropical, but one at least is Chinese.

*Pistacia* "Pistachio nut," has 8 species, from the Mediterranean, the Canaries, Mexico, and China.

*Schinus* has 13 species, one of which *S. molle* is familiar in Californian gardens. The leaves when broken and dropped on still water, seem as though endowed with the power of locomotion.

*Cotinus* "Smoke Rhus" has 1 species extending from Southern Europe all through temperate Asia. This is how some of the Kew publications put it, but others make it a Rhus! It varies, and we have a form on the Alleghenies, larger perhaps but not unlike it.

*Rhus* has 118 species, widely distributed over the world. Many are "Poison Sumachs," but several are handsome. Poison Rhus resembles the Virginia creeper (although it has but a tri-lobed leaf.) Children should be taught never to touch it, but should they inadvertently suffer from Rhus poison, a druggist should be asked to prescribe a solution of sodium hypo-sulphite for a bath. The inner bark of the Bass-wood (*Tilia*) soaked until it is saponaceous, and applied as a poultice with bandages is also said to afford relief.

The *Coriariae*, etc., are anomalous but pretty shrubs from the Mediterranean countries and the Himalayas, etc.

I have been greatly tempted to write a good many tender genera into this alliance, for they are often elegant greenhouse plants, and useful for the sub-tropical garden in summer, besides many of them may be expected to endure ordinary winters at the south, and even if killed to the ground occasionally such half herbaceous genera as *Melanthus* will grow again in spring. The Alliance contains a large number of species natives of the warmer parts of the United States.

Trenton, N. J.

James MacPherson.

#### The National Cemetery at Chattanooga, Tenn.

A bright Tennessee woman once remarked that in the blue grass region of that state they lived on the fat of the land, while in Chattanooga and its vicinity the natives lived on scenery and war relics. True it is that both of the latter are much in evidence in the Mountain City. Among the many points of interest about Chattanooga is the Federal, or, as it is commonly called, the National Cemetery. It is one of the beauties and show places of the town, as well as a place of national historic interest.

Just outside of the city limits of Chattanooga and about one mile due east from the court house, which is near the center of the city, there lies a tract of land comprising about 130 acres, which is the property of the government. Seventy-five of these acres are inclosed by a handsome stone wall, and form the picturesque and beautiful resting place of 13,107 union soldiers. There are two entrances to the grounds, one on Montgomery and the other on McCallie avenue. Both of these avenues are supplied with trolley lines, and so this cemetery is the most accessible of all the historic points around the Mountain City, being within ten minutes ride of the leading hotels. Perhaps this, in a measure at least, accounts for the number of visitors, there being an average of 70,000 admitted each year.

Nature has done much for the place, and those in charge have made no attempt to coerce her into strange and conventional forms. The site of the cemetery is a shapely knoll, with easy winding boulevards in all directions, and admirable shade is furnished both by the fine old native trees and others of more recent planting. On the apex of this knoll is a rostrum of rustic design and vine covered, from which a fine view of Lookout Mountain and Missionary Ridge may be obtained. This rostrum is used as a speaker's stand on the 30th of May of each recurring year, at which time the members of the G. A. R. meet to decorate the graves of their comrades.

Captain Trindle, the efficient superintendent, has been in charge for fourteen years and has many interesting things to tell, and is always courteous and affable to visitors. His house and office are near the center of the grounds and form a picturesque little group of buildings.

On the hillsides are the rows of graves, each marked with its separate stone, as the custom is, and several large shafts and monuments are to be seen. The most notable of the latter is the one erected by the state of Ohio in memory of the Andrews raiders; a picture of which accompanies this sketch. It was erected in 1890, and



in May, 1891, it was dedicated with appropriate ceremonies, Hon. J. B. Foraker, then governor of Ohio, being the orator of the day. The monument is of Westerly granite, crowned by an exact fac-

face the trees in any way.

One of the chief beauties of the place is the vines. They are everywhere—running rampant over the inclosing stone wall, festooning the superintendent's house, covering stumps of dead trees and, prettiest of all, twining and hanging from the great boulders and rockeries that adorn the western part of the cemetery. These rocks give just the needed touch of wildness that is indispensable in any beautiful grounds. Too much civilization, too great regularity, too palpable evidence of care is wearisome.

I remember one day when I was all out of tune with the world and every one in it, taking a walk in this particular portion of the cemetery. It had been raining and everything had



simile in bronze of the engine stolen by the Andrews raiders in what constituted one of the most daring incidents of the war. The eight men who suffered death as a result of their intrepidity are buried in a semi-circle on the west side of the monument.

There are no greenhouses on the place and no attempt is made at elaborate floral decorations, though in spring and summer some fine roses and geraniums are to be seen, and an occasional bright bed of coleus, alternantheras or other bedding plants. Much attention is given to the lawn and the shrubbery, which latter is wonderfully well selected and artistically arranged. In one particular spot, of which I was careful to obtain a photograph, I counted eight different kinds of foliage. Numerous and beautiful varieties of Thuya, or Arbor Vitae, of all sizes, colors and shapes, divide the honors with Hibiscus, Syriacus, Ilex, Euonymus and, in fact, every other shrub with which one is familiar, and many strange ones beside. Then in spring the flowering shrubs bloom their beautiful best against backgrounds of spruce, fir and cedar.

that delicious smell that always follows a much-needed summer shower, and the sky was still black and threatening. I stood looking up at those great rocks, whose time-worn faces were partially veiled by clinging ivy and ampelopsis. Suddenly the sun broke through the clouds, turning to gems the raindrops on grass and leaf, and resting lovingly upon those old gray rocks. It was all so beautiful, so grand, so different from the dead level of ordinary things. Beneath the largest rock is a cavern shut in by a heavy wooden door. It was once intended to convert this into a vault, but such use was never made of it. However, this



The native trees are mostly oaks of various kinds, maples and hickories. The children are allowed in autumn to gather the nuts that fall from the latter, though no one is permitted to climb or de-

door in the hill side, with its heavy chain and rusty padlock, has suggestions for the fanciful mind decidedly apart from the commonplace. Standing here on that quiet Sunday afternoon, I placed a





MONUMENT TO ANDREWS' RAIDERS.

loving hand on a bush of rosemary—rosemary signifying remembrance—and thought with Longfellow:

“If thou art worn and hard beset  
With sorrows thou wouldst fain forget,  
If thou wouldst read a lesson that will keep  
Thy heart from fainting and thy soul from sleep,  
Go to the woods and hills. No tears  
Dim the sweet look that nature wears.”

The frost of '94 injured some of the fine old box trees, favorites of all the old-timers who visited the place on account of their suggestion of old-home gardens.

This cemetery was established in 1863, and interments are still made on the average of twenty per year, any Union soldier having an honorable discharge being entitled to such interment. Many prefer sleeping with their old comrades to being placed with their families in other burying grounds, and so decree among their last requests.

Two thousand men who were killed outright on the battlefield of Chickamauga are buried here. Of those only 152 are known. The unknown graves are all marked with stones bearing a number.

On Sunday afternoons, when the weather is favorable, many visitors seek this quiet, beautiful place. Some drive, others stroll through the grounds—fathers and mothers with their children, groups of weather-beaten veterans talking over old times, sometimes a solitary figure, gowned in somber black, searching among the graves for the name of a lost loved one, and in contrast one often sees a youth and maiden strolling there with the wonderful light of love in their faces, youth and gladness in their step and joy in their tones. And so they pass and repass, an interesting throng, until

the signal gun is fired and the great iron gates are closed.

Louisville, Ky.

*Elizabeth Fry.*

#### An English House in Philadelphia.

It is with a great deal of pleasure the picture of this Philadelphia residence is presented to our readers. It is quite an every day affair to hear persons say that there is not the comfort and seclusion in our homes that there are in those of England, but it needs but to look on this picture to be convinced that there are both there, as indeed there is. Many of the older Philadelphia families were well to do Quakers, and in building their houses and arranging their grounds, they gave their first care to comfort and usefulness, letting mere ornamentation take a second place. On the outskirts of the city are still many of these old houses and grounds. The walls of the dwelling are overgrown with English ivy, and noble shade trees are about them and scattered through the grounds. The cut presented herewith represents such a place. It is on Lansdowne avenue, Philadelphia, and though no doubt when it was built it was far away from the city proper, it is now being encroached on from all sides by modern streets and dwellings. What our people must do if they would be so situated as the owners of this place are, is to plant for the future and be patient. Look at the magnificent elm tree overshadowing and protecting the dwelling, and think of the time it has taken to reach its grand proportions! It is almost useless for one to think to see a tree planted by himself reach the noble proportions of this one. But if judiciously planted, some one will enjoy it eventually. Although properties quickly pass from one family to another in our country, yet there are families in this city liv-



AN ENGLISH HOUSE IN PHILADELPHIA.



ing on the places their ancestors owned nearly 100 years ago, and what lovely places many of them are to-day.

The picture, too, well illustrates the fact that the English ivy flourishes well here. How nicely it has taken possession of the walls and of the spaces between the windows on the ground floor. And it has done just as well on the side of the house. Why it is that so many think this ivy will not thrive here I cannot understand. Yet I often hear it said that it will not. Speaking for Philadelphia, it is quite hardy. In quite sunny places I have seen its foliage badly scorched in severe winters, but in all other places it is perfectly green all the time. In Laurel Hill it has been largely used in cemetery lots, as it has been in other cemeteries, sometimes as an outline to a lot, and again for permanently covering graves; and in these and any other cases where the plants are near the ground, there is never the slightest trace of injury by cold. And there are many dwellings beautifully covered with it. It is common too, to see trunks of trees covered with it as is the one before us; and this body of green is so cheerful looking in winter. Old, partly decayed trees can be nicely covered in this way. When such is to be attempted, set the plants on the north side of the tree and if possible get a vine with a long shoot. Plant it some distance away from the tree and run the shoot underground to the trunk leaving but about 6 inches of the top to fasten to it. This is so that the root of the vine may be where it can get moisture and nourishment, to give it a start. If planted close to the trunk it can get neither oftentimes, and dies out, instead of starting.

The beautiful weeping ash in the illustration has been grafted on a quite tall stem, as it often should be. It is a common mistake to graft them too low. In English cemeteries and public grounds they are found on much taller stems than usually seen here. I remember some I saw in a cemetery at Newport, Isle of Wight, in the summer of 1895, which were on stems 12 feet high, and they had splendid spreading heads 12 feet in diameter. They presented beautiful shady retreats, as the branches arched until their tops reached the ground. And weeping lindens and weeping elms were there, and all had been grafted not lower than 9 feet. Our nursery-men do not graft such trees high enough. As generally seen the Kilmarnock Willow is about 5 feet, ash, linden and elm, 6 or 7 feet. Two or three feet more added to the length of stem would be a decided advantage. To have these trees of the desired heights, young trees for stocks could be set out and after standing a year could be grafted to whatever species was desired.

*Joseph Meehan.*

#### Hardy Woody Vines in Landscaping.

There is an expression in vines not belonging to trees. Yet, without the trees the expression is lost. Trees and vines are natural companions. A forest without vines appears rigid, lonely, deserted. Vines without trees appear a tangled mass of helplessness, but open, naked-armed trees, festooned with dependent, swaying vines forms one of the loveliest scenes in nature. It expresses the idea of the robust, strong, angular character supporting in sacrificial love the frail, the dependent, that must fall and perish without support, and in turn the idea of grateful embrace, of grace, of a robe of glory, spread and sustained by the tendrils of love, of comfort and binding up of the homely in the arms of beauty.

Some of the most affecting scenes in landscape I can recall among the many I have admired in journeying through great forests, were pieces of country roads usually approaching rivers or lakes, lined with trees of all sizes and numerous kinds, many of which supported canopies of grape vines, with their long, pendulous arms swaying to and fro in the breeze, as though they were trying to fan us in the sluggish air below; others with their old rugged bodies completely covered with a sheet of Virginia creeper leaves, so glossy and clean, and if in Fall, glowing with the richest scarlet and crimson; others dressed in the massive, compound, feathery leaves of the trumpet creeper, against which, as a background, nodded hundreds of the rich orange flowers in cluster, about which were circling richly hued humming birds, ever and anon dipping their tiny bills into the deep, richly-laden honeycups; others, usually sapplings, dedecked with a crown of the golden clusters of bittersweet (*Celastrus scandens*), and yet others bound round and round with Dutchman's pipe vines (*Aristolochia siphon*) and covered thickly with the large, heart-shaped, light-green leaves, among which peeped the odd flowers.

Such passages seemed to me in my reveries like some vast concourse of wild, yet friendly, sight-loving beings assembled to behold me pass by, and I would almost involuntarily lift my hat in recognition of the honor done me, and reverently smile back in their joyful faces.

What a magnificent, appropriate, consoling pageantry would such a drive be to lead the way to vaults in a cemetery, or down to and along river and lake bank in a park!

How grandly, nobly would it contrast with the rigidly artistic, open lawns and upland ways, made still more rigid by chiseled tombs and shafts of the cemetery, or the brazen figures, monuments and pagodas of the park!

In addition to such beautiful vine-hung drives there are many isolated spots in parks and ceme-



teries, where certain kinds of woody vines work in with excellent effect, as will occur to any landscape artist.

Among the grape vines the proper species for good effect in the north are *V. cordifolia*, *V. rubra*, *V. cinerea*, *V. riparia*, which can easily endure a temperature of 15 to 20 degrees below zero. Staminate vines alone should be used for such purposes, as fruiting vines are not suitable. South of latitude 36 degrees east of the Rocky Mountains *V. munsoniana*, a native of Southern Florida, and *V. monticola*, *V. berlandieri* and *V. champini* of Southwestern Texas can be employed along with the species recommended further north. The Japanese and American ampelopses do well both north and south. The bittersweet vine (*Celastrus scandens*) is a fine thing in the north, but cannot endure the extreme south. In its place south the trumpet creeper (*Tecoma radicans*) is very fine for some situations. A near relative of this last, the Cross vine of the south (*Bignonia capreolata*), an evergreen in the Gulf states, is fine for tree bodies. There are several species of *Cissus* native here from which good effect can be had. *C. incisa*, with very fleshy leaves, as a very graceful, slender vine for trellises and places where ivy appears well, is much hardier to endure heat. Only in the coolest situations do the ivies succeed well in the south.

Of all the rampant growers, yet slender, perfectly drooping, most graceful, with small, smooth, shining, toothed leaves, becoming fine scarlet and crimson very late in Fall, the *V. munsoniana* excels. It endures a winter temperature of about 5 degrees below zero and any amount of heat and drouth. I regard this as the finest ornamental woody vine known for the Gulf states. Its nearest relative among grapes is the common Muscadine of the south, which, though much coarser, is a splendid vine for massing over a thicket. Almost any of the vines I have named are prettier than the coarse, dirty Wistarias. Yet, the latter is used much more than any of them except the Ampelopses and Ivies in the north in home decorations.

The Mustang Grape (*V. candicans*) of Texas and the Fox Grape (*V. labrusca*) and Summer Grape (*V. astivalis*) of the east and south are too coarse, filthy and rigid to use to much advantage in landscaping, but can (especially the Mustang) make great canopies of large leaves in open exposure on frame work, but suggest little more than the idea of a vineyard.

Why it is that vine work, such as I have hinted at in the first part of this loosely constructed paper, is not more used by landscapers I cannot well imagine. Certainly the better parks and cemeteries do not lack real artistic talent to use such effectively. Nor is such work expensive to establish and main-

tain. Probably the main reason is lack of examples to set the pattern, for even in landscaping few are bold enough to leave the beaten paths and be strikingly original and natural, and also because few florists and nurserymen keep in stock such vines and advertise them.

There are yet some other woody vines which could be used with effect, but the aforementioned are abundant, with which artists can produce wonderful effects. However, I will call to mind one other remarkable genus of vines represented by nearly a dozen species in the United States. It is *Smilax*, the Greenbriars. What queer and beautiful works in landscaping might be worked out of these! Even the glorious climbing roses have nothing in beauty of foliage or freshness to compare with them.

T. V. Munson.

---

#### Notes.

Every head of red clover consists of about sixty flower tubes, each of which contains an infinitesimal quantity of honey.

---

Referring to the article on food-bearing trees, page 372 of the last issue, Mr. James MacPherson says: The tree you notice appears to be *Butyrospermum Parkii*, Mungo Park's butter tree, long regarded as a *Bassia*, and so spoken of in the dictionaries. The *Bassias* are all East Indian and have similar properties; *B. butyracea*, *B. longifolia*, etc., yielding buttery products useful for lamps, soap making and sometimes cooking or food. The nearest thing we have to them is the *Beumelias* of the southeastern coast lands, the fruits of some of which are "milky."

---

Last summer, when botanizing in the vicinity of Millville, N. J., I came on on what was to me a great curiosity in the shape of a dwarf form of the Black Jack Oak, *Quercus nigra*. In botanical works this oak, *nigra*, is described as a small, gnarled tree, with a trunk 20 to 30 feet high. I had been accustomed to seeing this oak in great quantity all throughout South Jersey, and of various sizes, but near me on the occasion referred to were quite a number of trees full of acorns of all sizes from 2 feet up to 20 and 30 feet of the botanies. And as it was a good season for acorns of most all kinds, these little dwarfs were just as full of fruit as they could be. It was a pleasing surprise to me, the more so as the little fellows were not of stunted growth, but appeared as vigorous as the largest ones. Should this dwarf feature be a permanent one, as I have no doubt it is, this little oak would be a beautiful lawn ornament, as *nigra* has long been admired for its large pretty shaped, shining green leaves.—Joseph Meehan in *Meehan's Monthly* for December.



## PARK NOTES

Easton, Pa., has accepted a proposition of Mr. D. W. Nevin to deed a tract of land to it for \$1.00 as a gift for a public park. It will also be of practical usefulness as a drainage area to carry off storm water from College Hill. It will be called "Nevin Park."

\* \* \*

An elaborate report upon a park system has been presented to the Oakland, Calif., Board of Trade from its special committee. Lyman Bridges, C. E., consulting engineer of the Board, advises that not less than four parks should be considered with approaches and connecting boulevards, covering not less than 3000 acres.

\* \* \*

The Brooklyn, N. Y., Tree Planting and Fountain Society have been taking active steps to have the ordinance against using trees for bill posting properly observed. The society is in earnest in its endeavor, and it would appear that the custom has become quite common resulting not only in the defacement of the thoroughfares but the destruction of the trees.

\* \* \*

The plan for the Marine park at Newport, R. I., as designed by Olmsted & Eliot proposes an artificial beach, 925 feet long, with bastions at each end and a wall in front. On the rear of the strip a lawn with shade trees is suggested, to be used as a playground in summer, and flooded for a skating rink in winter. An aquarium may also be made a feature of the scheme.

\* \* \*

Of all the proposals that have been submitted to the French government with regard to the well-known Palais Royal at Paris, which is fast falling into ruins, the scheme which finds most favor with the government and with the public is that of covering in the whole garden or square with a huge glass roof, converting it into a hothouse, or winter garden, for the reception of tropical plants.

\* \* \*

The force of laborers at work in Grower's Woods, near Richmond Hill, Long Island, on a new park for Brooklyn, are in constant fear of dynamite, some fifty pounds of that material having been buried somewhere in the grounds about three years ago. This had been collected by an anarchist colony located at Maspeth and on their dispersal by the authorities, the stuff was ordered to be buried. This was done by the constable who is now unable to locate the exact spot at which he deposited it.

\* \* \*

City Park, Delaware, O., a small park and not particularly well situated, is under the care of David Grinton, who is also secretary and superintendent of Oak Grove cemetery of that town, and who has done duty in this dual capacity for a number of years. Speaking of water lilies as an attraction, he has used them in the cemetery for seven years past, and last year made his lily pond a prominent feature in the little park and with great success. The coming spring it is intended to improve the planting of the park by a number of beds of flowering perennials. The smallest of our parks may be made perennially attractive by intelligent care and forethought.

\* \* \*

Judge Alfred C. Coxe, United States District Court, Utica, N. Y., recently delivered an address before the Oneida Chapter of the Daughters of the American Revolution, in which he criticized the location of the memorials of many of our great men. Among many he referred to the memorials of General Herkimer, the Revolutionary soldier, one of which has recently been unveiled over his grave, all of which are virtually inaccessible to

the general public. He suggested that the public park is an appropriate place for such memorials, so far as they can be judiciously accommodated, thus affording object lessons to the greater number. This is a matter of great importance, and should be carefully noted for consideration as opportunity arises.

\* \* \*

There is a growing sentiment in favor of preserving certain localities, famed for natural beauty of development, against the depredation and destruction constantly progressing in and about them. This is especially marked in regard to the localities containing the groves of big trees, and other beautiful natural features in California. State legislatures have never proved very effective in their efforts to protect such desirable attractions; too many private interests to serve and schemes to develop have been detrimental to such enterprise. It is to the National government that the public is looking for the preservation of such grand examples of nature's handiwork which we have in certain parts of the country, and seeing that once despoiled they can never be replaced, and that such natural features of our country exercise not only a fascination but an educating influence fraught with much good, it would appear to be the duty of congress to pass such acts as will create for the people national parks about and to include these natural wonders, so as to preserve and protect them for all time.

\* \* \*

The Managers and Board of Commissioners having in charge the creation of the Botanical Garden in Bronx Park, New York, have agreed upon plans. The *New York Advertiser* says: In the report attached to the plans the Board of Managers state that they will endeavor to preserve the present topographical appearance of the park. Some changes must be made, however. These include the making of a large artificial lake at the junction of Mosholu Parkway and the Southern Boulevard. A number of new driveways macadamized and systems of footpaths will be constructed. The principal building to be erected will be a museum located about 1,000 feet from the Bedford Park station, which will cost \$250,000. It will be 304 feet long, with two lateral wings of 200 feet in length and 57 feet in width. The building will be arched over with glass. Houses for the head gardener and staff will also be erected. Thirty acres of the 250 will be devoted to tree growing, fifteen to woodland plants and shrubs and five to bog growing plants. The Bronx River will be lowered two feet by removing part of the dam in front of the Lorillard house. A stone wall will be erected around the entire tract. A number of gifts have already been received for the new garden.

\* \* \*

The conservatory which the South Park Commissioners, of Chicago, are about to erect in Washington Park are from designs by D. H. Burnham & Co. The plans contemplate a building 418 feet long and 61 feet wide in the central pavilion. The latter will front eighty-two feet each on the avenue and toward the park, and on each end of the building will be a pavilion, 53 by 63 feet by 46 feet to the apex of the dome. The center pavilion will be 56 feet high. To a height of about five feet the walls will be constructed of cut stone upon a foundation of rubble masonry, and the entrances at either end, designed in the Renaissance style of architecture, will be carried out in terra cotta. There will be a terraced slope toward Cottage Grove avenue sodded, with the exception of the broad steps leading up to the center pavilion, and there will be planted a profusion of bushes and shrubbery to conceal the barren walls. The center pavilion will serve as a palmhouse. The roof will be of ribbed glass and iron and Florentine glass will be used for the perpendicular walls. All the entrances will have marble wainscoting, plate glass and mosaic floors. Toward the park side the ground floor of the conservatory will be on level with the turf. It will cost about \$50,000.



## CEMETERY NOTES.

A mausoleum to cost \$6,000 is to be erected in Harleigh cemetery, Camden, N. J. Messrs. Gessler's Sons of Philadelphia have been awarded the contract for the work.

\* \* \*

It is said that the defalcation of the late cashier of the First National Bank of Lebanon, Pa., also involves the Mt. Lebanon Cemetery association to some extent, he having been secretary of that association.

\* \* \*

The annual report of Oakland Cem. Assoc. St. Paul, Minn., shows receipts for the year \$20,803.35 and the ordinary expenditures for same period \$19,470.20. The sales from the greenhouses amounted to \$3,923.15 in addition to what was furnished for use in chapel and grounds, equal to \$1,328.55. The principal of the perpetual care fund amounts to \$80,591.92 and the working fund to \$9,662.25; of these \$87,700 is invested and draws interest. Sales of lots amounted to \$7,338 and single graves to \$1,132; interment fees were \$1,783 and tomb fees \$471.50.

\* \* \*

It has been suggested that as the tulip is a flower that practically makes a season for itself in our northern latitudes, and that otherwise as the supply of blossoms for Decoration Day is very limited in variety, that a special bed of the finest tulips should be planted as a Memorial Day bed, from which to cull flowers for the National ceremony. A bed of tulips, of colors, suited to the occasion, planted with a liberal hand would afford a constant supply at the proper time, and a bouquet of white, lavender and pink tulips is a thing of beauty, in decided contrast to the more gorgeous varieties unwittingly collected as a rule.

\* \* \*

Extensive improvements are under way in Woodlawn cemetery, New York, some 15 acres of new sections are now in progress. It requires about four acres per year to keep up with sales of lots. During the past season there have been erected three mausoleums and one side hill vault. The Kountz Memorial erected this year stands about 40 feet high with first base of 21 feet square. It is constructed of Concord granite. A shaft monument of Westerly granite is now in course of erection. Its total height is about 60 feet of which the shaft alone measures 45 feet and weighs between 50 and 60 tons. Several foundations, 16 to 18 feet square, have been built this fall for monuments to be set next spring. The Clark mausoleum, a costly structure, will not be finished until next spring.

\* \* \*

From reports of responsible florists as well as cemetery officials, there appears to be a well organized system of flower stealing from the newly made graves in the Chicago cemeteries. In some cases it is asserted that costly floral pieces are made to do duty on more than one occasion, the piece being stolen on the night of its first use and resold the following day. Cemetery officials are at a loss to know how to prevent this depredation, for it is evidently carried out by experts, but there must be unscrupulous dealers in the scheme, or the vandals would find it unprofitable. It is well-known that certain of the flowers which are generally the expensive kind used in funeral ceremonies, keep in excellent condition for two or three days, and it is this feature which makes stealing the flowers profitable, as well as the frames upon which they are set.

\* \* \*

Kahbakong cemetery is situated one mile from Taylor's Falls, Minn., and was organized in 1855. Its name is derived from the Chippewa Indian designation of St. Croix Falls, near

by. It contains 15 acres and owing to the sparsely settled country, bodies have been interred there brought from 50 and 100 miles distance. It has a naturally beautiful location. Its roads and by ways are 20 and 13 feet respectively in width, and its blocks 30 by 40 feet, subdivided into smaller lots. At one end is a trap rock formation rising some 50 feet above the grounds, upon which it is expected to erect a soldier's monument, 31 Union soldiers being buried here. At the last annual meeting the lot owners voted to erect a shelter house with seats and other conveniences. Water is supplied by a windmill from a well 100 feet deep. Mr. W. H. C. Folsom has been connected with the association from the organization and he with many other interested well wishers undertake the care of the grounds.

\* \* \*

The work of converting the old St. John's cemetery, at Hudson and Clarkson streets, New York City, has been postponed and probably until spring. As has been stated it occupies an acre and contains graves of persons buried as early as 1799 and as late as 1858. Although all possible notification has been given by the authorities, very few have taken any interest in the removal of the remains, so that the bodies will be left undisturbed and the grave stones buried in place. The great majority of interments appear to have been of the poorer and middle classes, though a few well-known names are found. The place had become a forlorn and dilapidated graveyard. The most pretentious monument was that erected by friends and members of Fire Engine Company No. 150, to the memory of the men who lost their lives by the falling of a building while engaged in the discharge of their duties as firemen, July 1, 1834. The firemen desire to have this monument retained in its present place and position after the cemetery becomes a park, which will probably be considered by the commissioners. The earliest decipherable date on any of the tombstones says the *New York Times*, is 1799. This slab bears the following inscription:

A Monument.  
In Friendship Rendered  
Sacred to the Memory of  
Mrs. Elizabeth Lawrence,  
The Wife of Mr. John Lawrence,  
Merchant, of the City of New York.

Amidst surrounding numbers she fell a victim to Death's unerring shafts. Adorned with virtue, elegance, and grace, she discharged with unremitting care the duties both of social and domestic life. To the world in general and her sex in particular she was an amiable pattern of exalted goodness. With manners mild and engaging, with an understanding highly cultivated and improved, with a fancy lively and brilliant, with a flow of language correct, smooth and elegant, with sincerity undisguised and pure and valued affection, long will she live in the hearts of all the good and virtuous.

Sacred Spirit,  
Rest in the realms above and indulge to relatives and friends the only solace left,  
To shed over thy grave  
A parting Silent, Melancholy Tear.  
Died 16 Oct., A. D. 1799. Aged 57.

\* \* \*

A down east paper says the *New York Times*, supports one of its correspondents in rather angrily denying the assertion made by a writer in an English Magazine that people living in New England villages often remove the silver name plates from the coffins of relatives, after the funeral services are over, and with them decorate their parlor walls or mantelpieces. The denials in each case are made on what is declared to be long familiarity with New England customs, and the suggestion is made that "the English writer has probably generalized from a single instance, after the manner of other travelers." Now, as a matter of fact, the Englishman's statement is perfectly true, not only as regards the past, but as regards the present also. This use of coffin plates did and does prevail in many parts of New England, and the practice is far from unknown in this state. At least one



such parlor ornament can be seen in a Long Island village much frequented by summer boarders, and the writer of this paragraph has seen dozens of them in parts of Maine that pretend to be, and for that matter are, fairly well civilized.

#### Cremation.

Cremation in the United Kingdom, in the hands of the Cremation Society of England, is gaining ground according to the report for 1895. The society's council includes many distinguished names, the president being Sir Henry Thompson, F. R. C. S. At the Woking Crematory there were 150 cremations in 1895, as compared with 125 in 1894; while at Manchester there were 58 in 1895. At the time of the issuing of this report these were the only crematories in operation in England, but at Glasgow a fine plant had been recently opened and progress was being rapidly made in relation to one at Liverpool. The society has been actively at work to secure proper amendments to the laws regarding records of causes of death, with a view to removing one of the great objections to the process from a legal standpoint, the concealment of crime, or the possibilities of the necessity of gathering evidence by exhuming bodies. The matter will be agitated by the society until the laws are satisfactory on the question. At the present time the society will not carry out a cremation except upon the strictest inquiry and upon the properly attested death certificate devised by the society.

The importance of this question was early appreciated by Sir Henry Thompson, as will be seen from the following extract from a paper read by him on the subject of cremation:

"This being so, I venture to affirm that this important question demands solution before we are permitted to undertake the practical resort to cremation of human bodies *on a large scale*. Up to the present time I have myself in every instance been responsible for the careful investigation of the papers connected with every case sent to Woking for cremation, having drawn up a special short series of questions constituting the death certificate on which we rely as the initial step in the process. Then, having considered the evidence thus brought before me, I have declined every case not free from doubt or objection, and demanded an adequate necropsy sufficing to solve it as an indispensable condition of cremation. This is not a matter of difficulty with small numbers, but with large numbers it is obvious that some such stringent method must be made legally binding in all cases."

"Advocate as I am and long have been of cremation as one among the most important and necessary reforms, I would discourage (as I have, indeed, for years persisted in doing) a wide and general application of the process until the law demands a

proper examination of the circumstances of death in every case. The present method of certifying the cause of death throughout Great Britain is grossly inadequate, and is now widely known to be so. When first advocating cremation twenty years ago (if I may be forgiven for once more alluding to the effort then made), I did not dare to do so without then prominently stating that the authorized precautions in the matter of the death certificate \* \* \* are defective and inadequate to the end proposed, and much less efficient than those adopted by foreign governments, adding that if the public is earnest in its endeavor to render difficult or impossible the crime of secret poisoning, the sooner some measures are taken to this end the better, whether burial in earth or cremation be the future method of treating our dead."

Extracts from a discourse of Dr. W. R. Burr of Auburn, Ky., given in *The Casket* for November, will serve to show how thinking over the subject is weakening the objections. He says:

"But, notwithstanding the general disapproval of cremation by the religious world, quite a number of the leading theologians of the age have signified their approval of the method. Among them may be mentioned such men as Phillips Brooks, Edward Everett Hale, Robert Collyer, H. C. Potter and Heber Newton.

"Another objection that has been urged against cremation is that it destroys all the tender feelings and memories associated with friends who have departed life. This, too, is morbid sentimentality and not reason. The memory of departed friends and relatives and the pleasant associations we had with them when they 'lived, moved and had being' can be affectionately and tenderly cherished, no matter what disposition was made of their lifeless bodies. Besides memory of the dead usually lasts but for a generation and they are forgotten, and their names and resting places are blotted out. Love, affection, sentiment and tender memories of departed loved ones should abide in us, and, indeed, this would be a cold and pulseless world without such feelings, but we should have sufficient love for science and regard for the living not to allow our dead to be the cause of disease and destruction.

"The day will come, although this generation may not see it, when cremation will be the universal practice, and a potent source of infection and death will be wiped out. Cremation has been growing fast in favor since Sir Henry Thompson brought it prominently before the public in 1874 and formed the Cremation Society of London. He proposed to 'resolve a dead body into carbonic acid, water and ammonia rapidly and unpleasantly.' That cremation does this no one can deny."



### Association of American Cemetery Superintendents,

G. W. CREESY, "Harmony Grove,"  
Salem, Mass., President.  
ARTHUR W. HOBERT, "Lakewood,"  
Minneapolis, Minn., Vice-President.  
F. EURICH, Woodlawn, Toledo, O.,  
Secretary and Treasurer.

### Publisher's Department.

Park Commissioners and Cemetery trustees are requested to send us copies of their reports.

Photographs and descriptive sketches of interesting features in parks and cemeteries are solicited from our readers.

Mr. G. W. Creesy, the recently elected president of the A. A. C. S., writes that he made a number of very pleasant visits en route home from the St. Louis convention. At Riverside, Cleveland, he had the distinction of being the first person to cross the beautiful new bridge which had just been completed. In company of Superintendent Dix of Riverside he went to Akron, a distance of thirty-eight miles, by electric cars and visited Mr. Sargent at Glendale. At Rochester, N. Y., a pleasant stop was made with Mr. Shepard, whose cemetery "is to surpass all others if continued along its present lines of improvement." At Oakwood, Syracuse, Mr. Chaffee was found to be nicely situated in his new home just outside the cemetery grounds. These social visits to and from the conventions are very pleasant and profitable features of the superintendents' vacations, which many of the superintendents make the most of.

The Michigan Agricultural College, Lansing, Mich., is offering excellent opportunities to young people either engaged in, or contemplating the immediate use of the knowledge obtained, short courses in special lines of practical farm work, both as relating to stock and cultivation of the land. For this work the college has exceptionally good facilities: Herds of thoroughbred stock, large forcing houses and greenhouses, which with laboratories, library and competent instructors, makes instruction comprehensive and practical. Commencing January 4 next, there will be offered a six week's course in dairy husbandry, also a course of lectures

and demonstrations in dairy chemistry. Another course will be live stock husbandry. Two other special courses will be along horticultural lines. It is estimated that the minimum cost including fees and board near the college, but excepting railroad fares and extra expenses, will not exceed \$25. Persons of good moral character, over 15 years of age, will be admitted without examination. To the faithful and enthusiastic student this will be a great boon, and will serve for a foundation upon which to carry on further work at home impelled by the ambition thus encouraged.

#### RECEIVED.

Proceedings of the twelfth annual convention of the Society of American Florists, held at Cleveland, O., August 18, 19, 20 and 21, 1896.

By-laws and Rules and Regulations of Oak Grove Cemetery, Delaware, O.

New York Agricultural Experiment Station. Bulletin No. 107, new series, August, 1896. Report of Analysis of Commercial Fertilizers for the Spring of 1896. L. L. Van Slyke.

Bulletin No. 208, September, 1896. The Real Value of "Natural Plant Food." L. L. Van Slyke, Geneva, N. Y.

Oberlin (O.) Cemetery Association—Its officers, history, constitution, rules and regulations.

The twelfth annual issue of the *Columbia Pad Calendar* has come to hand with several appropriate changes, many illustrations and suggestive thoughts for every day of the year. Among the topics are bicycling, outdoor life and good roads. The cycling fraternity, as well as the general public, appear to entertain a decidedly friendly feeling for the *Columbia Calendar*, and its annual advent is looked forward to with interest and pleasure. It is issued by the Pope Manufacturing Company, Hartford, Conn., and may be obtained by addressing the Calendar Department and inclosing five 2-cent stamps

MORTUARY LAW. By Sidney Perley of the Massachusetts Bar. George B. Reed, Publisher, 4 Park street, Boston, Mass. Large 12 mo. Law sheep. 220 pages. Price, \$3.

This useful volume is a timely one for cemetery officials, for as the preface to the work says that while "the great body of mortuary common law continues to be maintained in the United States," various state legislatures have changed and extended it in certain respects, and this information in authentic form is a necessary and valuable adjunct of the cemetery superintendent's and official's library. The

increasing attention given to the public health, and the strictness with which the laws in this respect are being enforced, makes it imperative that cemetery associations should watch with the greatest of care the requirements of such legislation, and even anticipate it by careful amendments of the rules and regulations as circumstances suggest. The following enumeration of the heads of the various chapters of this work will explain its scope: Last Sickness; Records of Deaths and Burials; Mutilation of Dead Bodies; Property in Dead Bodies; Custody of Dead Bodies Disposition of Dead Bodies; Undertakers; Funerals; Funeral Expenses; Monuments, Gravestones, etc.; Permits to Transport; Bury and Exhume Dead Bodies; Transportation of Dead Bodies; Exhumation of Dead Bodies; Cemeteries; Prohibition of Cemeteries; Acquisition of Cemetery Lands; Cemeteries as Nuisances; Cemeteries as Charities; Rules and Regulations; Taxation Sale; Mortgage and Partition of Cemetery Property; Care and Conduct of Cemeteries; Rights and Liabilities of Lot Owners; Replevin; Larceny; Desecration of Cemeteries; Opening Highways Through Cemeteries. Abolition of Cemeteries; Jurisdiction of Courts. In this work there are over 700 citations from American and English law reports.

FLOWER QUERIES—Five hundred Questions on Practical Floriculture Answered and Topics Discussed. Price 25 cents. J. W. Darrow, Publisher, Chatham, N. Y.

This is a series of questions and answers on practical matters of floriculture in pamphlet form. It is divided into the following chapters: Soil and General Cultivation; Bulbous Plants, Lilies, Culture and Care; Rose Culture; Vines or Climbers; Shrubs; Ferns and Palms; Insects and Diseases; Miscellaneous Queries; Floral Hints; Index.

#### Testimonials,

"We are and have been subscribers of your valuable paper, PARK AND CEMETERY, and prize it highly."

R. H. Oakley,  
Treasurer Wyuka Cemetery, Lincoln, Neb.

"PARK AND CEMETERY is very useful to us, and each number is carefully read."

Geo. A. Clugston,  
Secretary Mansfield Cemetery Association, Mansfield, O.

"I shall be happy to contribute some matters of interest to add to the spicy columns of your almost perfect publication."

B. D. Judson,  
Superintendent St. Agnes Cemetery, Albany, N. Y.



# PARK AND CEMETERY.

FORMERLY THE MODERN CEMETERY.

A Monthly Journal Devoted to Parks and Cemeteries.

R. J. HAIGHT, Publisher,  
334 Dearborn Street, CHICAGO.

Subscription \$1.00 a Year in Advance. Foreign Subscription \$1.50.

VOL. VI. CHICAGO, JANUARY, 1897. No. 11.

## CONTENTS.

EDITORIAL.....	397
PARKS—TREES INTERFERING WITH ROADS.....	398
HANGING GARDENS OF BABYLON.....	399
*THE RIVERSIDE CEMETERY OF NORRISTOWN, PA.....	400
HYBRID SPECIES.....	401
KENTUCKY NOTES.....	402
*THE OLD CHURCH, BONCHURCH, ISLE OF WIGHT, ENGLAND.....	402
WATER LILIES—WATER PLANTS AS LANDMAKERS.....	404
*GARDEN PLANTS—THEIR GEOGRAPHY XIV.....	405
*BRICK ROADWAYS.....	407
*THE URI BALCOM MONUMENT, OAKWOODS CEME- TERY, CHICAGO.....	408
GLASS BRICKS IN HORTICULTURAL BUILDINGS— CAVE HILL CEMETERY, LOUISVILLE, KY.—CLERGY- MEN AIDING IN MODERNIZING CEMETERIES.....	409
LEGAL.....	410
PARK NOTES.....	411
CEMETERY NOTES.....	412
CORRESPONDENCE.....	413
PUBLISHERS DEPARTMENT.....	414

\*Illustrated.

IN another column will be found an article suggesting, as it were, the relations of the clergy to the cemetery. It is a live and timely subject, and the wonder of it is that the clergy have not taken far more practical interest in cemetery matters than is recorded of that reverend body. The relation of a clergyman to his flock is such that he is brought very near to the individual members when their earthly career is closing, and usually he is a prominent figure in the final commitment of the remains to mother earth. And these close relations give him both opportunity and force to press upon his people the propriety, as well as necessity, of interesting themselves more positively in the affairs of the cemetery as an important feature in the duties of life, for it is the living who have necessarily most interest in the burial plot. It is really a duty the clergy owe to the community, albeit erstwhile neglected, of impressing upon their congregations the desirability as it is their duty, all things considered, to materially, as well as morally, aid in the work of making the cemetery a spot to be cher-

ished and revered. By education, by association, by special duty, they are eminently qualified for the work, and we emphasize the suggestion that unmistakable good will result from their more active sympathy in cemetery matters.

"PARK making as a National Art" is the subject of an article by Mary Caroline Robbins in the current issue of *The Atlantic Monthly*. It touches upon the progress of park making in the principal cities wherein its highest development is to be studied, and suggests its possibilities and the probable fact that in the designing and carrying out of our great park projects a distinct line of national art may result, which cannot but prove of permanent benefit to the American people. It is unquestionably true that this country offers a field for landscape art unknown anywhere, and a field that has been, as yet, scarcely touched, there being but very few names on the roll of honor in this direction. But the last ten years has witnessed a wonderful progress in both the acquisition and development of park lands for the people, and with this landscape art is receiving an impetus which the people will surely encourage. Perfection of landscape work lies in the sagacious use of nature's lavish materials to reproduce her best effects where required for the immediate benefit of mankind, and to reproduce her in such moods as give rest and healthy stimulus. This is, after all, the chief end of the park—after recreation the rest, and the drinking in of the unseen stimulant permeating the atmosphere about beautiful landscape pictures; and to the end of producing such an order of landscape must the student of this order of art attain. The present attitude of the people is towards acquiring ample land for park purposes, which is the proper policy to pursue, but the people must be educated to the idea that it is not alone the purchase of the land and the laying it out that makes the park, but its permanent maintenance. Age adds to the beauty of the landscape, but to maintain it in growing beauty the people must willingly contribute to the cost. By properly inculcating this idea into the public mind we shall be able to avoid the conditions which are frequently presented of lack of funds for park purposes.



### Parks.

The following extract from a paper by Mr. J. F. Foster, C. E., superintendent of South Park, Chicago, read before the Western Society of Engineers, contains some pointed suggestions:

"The location or selection of grounds for park purposes is, unfortunately, rarely a matter of the adaptability of the site, but is more apt to be determined by the consideration of the effect it will have upon the real estate in this or that location, or, as frequently happens, the land is good for nothing else; therefore it will do for a park. Such being the case, the converting of the swamp, rocks or sand plane, as the sight is apt to be, into a park, is not only expensive, but usually attended with unsatisfactory results on account of the want of funds to do the right thing. The designer of a park is asked to take one of these usually unpromising pieces of ground (at least, so they have been in our locality,) and submit a plan for its development into the finest park in the country, for you know that is what every community expects its park to be. He must emphasize in his design any natural feature connected with the site which it is desirable to retain, and must obliterate all undesirable features. He must ascertain what trees and shrubs can be best depended upon to make thrifty and permanent growth in the location selected, and what must be done to the earth to make it suitable for plantation. Then he must study the requirements of the people by whom the park is to be used and provide for their absolute wants, and at the same time perhaps open to them unknown pleasures, and teach them to enjoy nature in the quiet way which affords the greatest pleasure. By providing for the wants of the people of the locality I don't want to be understood as saying that if he finds a number who are interested in prize fighting, or cock fighting, that places shall be provided for such things; on the contrary, parks generally are too much devoted to exhibitions of various kinds, such as match games of ball and cricket, and races of various kinds, the competitors being semi-professionals or club organizations. A park is no place for such contests. The playing of games should be confined to those who indulge therein simply for recreation, not as an exhibition of skill. With such restrictions the playing of games would be confined largely to school children who would be just as well satisfied with any stretch of lawn for their game as with a place especially prepared for it. The same should apply to the riders of bicycles; no racing should be permitted, but ample provision made for the full enjoyment of the parks by those who visit them on wheels, such as broad drives, and, where required, cycle paths, also places where

the wheels can be safely left while the owner is otherwise enjoying himself; but the construction of racing tracks seems to me to be diverting the uses from the high grade of reposeful recreation which is primarily its object to that feverish excitement which may be found at the side of the tracks of Roby or Hawthorne. It seems to me that all such things should be avoided, and that a board of commissioners err when they think that they must respond to demands made upon them to furnish a place for every class of amusement. It should be borne in mind that usually those making the demand are so interested in the accomplishment of their object that they have little or no thought to give to the effect a compliance with their wishes would have upon the enjoyment of the park by all others who visit it. Frequently the park trustees are so interested in pleasing an insistent class that they forget the great primal object of the park, which is not, it seems to me, to enter into free competition with every race track, ball park, merry-go-round, etc., in the locality. But to return to the designer and his task: He, of course, must provide for boating, for driving, for riding, for walking and wheeling, to what extent for each he can only determine after carefully studying the situation and estimating to the best of his ability the probable needs when the population of the territory for which the park is to be the recreation ground has reached its maximum. These wants he designs his park to meet, mingling together as best he can the natural and necessary in his plan, and the nearer he can come to satisfying the desire of all who visit the park to behold the beautiful work of nature, and at the same time make it accessible in all parts with little or no obtrusiveness of walks, roads, bridges, buildings, etc., the more nearly will his plan be a success.

---

### Trees Interfering With Roads.

Some little time ago in an article on landscape work which appeared in PARK AND CEMETERY was the statement "The direction of roads and carriage drives frequently has to be changed in order to prevent the destruction of trees," or words to that effect. Often this is too true. But the question arises whether it is advisable to sacrifice the symmetrical and true curves of a road which is presumably to last for all time or remove a tree, which at the best has only a fleeting existence, and can be replaced in the course of a few years and its removal be unnoticed. In cemetery work more particularly is the carriage way of greater importance, for when the sections on either side have their silent tenants, the road cannot be changed.



In many cemeteries roads can be found that have in their past been diverted from what was undoubtedly their proper direction in order to spare the lives of forest trees, since dead. The roads appear as unsightly monuments of unskillful landscape engineering. During the past summer, in constructing a new burial ground considerable timber was interspersed throughout a valley where it was intended to run the main avenue. The Trustees were anxious to preserve these trees, and wished the roads to wind in and out, so as not to interfere with the trees, the removal of which, in their opinion, would spoil the beauty of the landscape. The proposed carriage ways were frequently staked out, but it was apparent to the most casual observer that they were unsymmetrical. Some portions were too straight and turns sudden, to the dissatisfaction of all concerned. So the superintendent took matters into his own hands, laid out the roads where they should be, irrespective of trees, and when they were completed was highly complimented upon the graceful curves. The remaining timber, though not so dense, stands out bolder, and the uninterrupted view of the avenues forming vistas, adds considerably to the beauty of the scenery. During the progress of the work, dire prophecies were uttered by a number of the older citizens who did not neglect to let the poor superintendent know their opinion, to his great discouragement. The "know alls" were in the majority. But after completion it was astonishing the number of "I told you so's" that sprung into existence, leaving but a small portion of the credit to the superintendent. Indeed, the latter is getting to be a little doubtful whether the work emanated from his brain, or was performed upon the advice of his friends.

By no means does the writer advocate the ruthless removal of trees, but maintains that when it becomes a question of the "survival of the fittest" then a beautifully curved and graded road is the fittest.

Another instance that came prominently under notice in years gone by, a grand old oak had interfered with the proper grading of the main drive to the cemetery. For years it had obstructed a perfect view along the road. In order to respect this monarch of the forest, a sharp rise in the grade of 15 feet in 300 was required with a corresponding dip on the reverse side. To have dared mention cutting down this venerable tree would have been deemed next to sacrilege. The sudden rise in the road did not affect riders in vehicles, and of course the poor horses could not feel it, and it was so pleasant upon hot days to pull up under the shade of the wide spreading branches and cool off.

But with the advent of the bicycle, riders of the

wheel heartily condemned such a sudden ascent which required the efforts of the strongest to surmount. The majority had to dismount and foot it. Then but few admired that beautiful tree. It was voted a regular nuisance. Whether Dame Nature heeded the maledictions of the wheelers or not is difficult to say; but one night a moderate cyclone swept along the road and twisted off the oak close to the ground; singular to say, the only tree in the locality to suffer, but the heart was decayed nearly throughout. When the debris had been cleared away and the crest of the knoll cut off, the improvement was marked, giving a commanding view of the road for some distance. Some ill natured persons unkindly hinted that the superintendent had something to do with working up that cyclone. But perish the thought. Cemetery superintendents are not as a rule, thin skinned, consequently the remarks of riders in vehicles did not affect this one. "Woodman spare that tree" is beautiful in sentiment but when cemetery officials have to do with cold blooded matters of fact, good and well laid out avenues are imperative.

*B. L.*

#### **Hanging Gardens of Babylon.**

The hanging gardens of Babylon and the walls of that famous city, two of the seven wonders of the ancient world, were the work of Nebuchadnezzar, the "builder king" of the "queen of nations," who is said to have rebuilt or repaired nearly every city and temple throughout Babylon. These gardens he built to delight his Median queen, Amytis, to whom the flat plains of Babylon were monotonous and who longed for the mountainous scenery of her native land. They covered a square, each side of which measured 400 feet, and were arranged in a series of terraces, four in number, rising one above another in graceful lines from the banks of the Euphrates to the summit. The ascent from terrace to terrace was by steps and the terraces were supported by pillars upon which were laid flat stones, and upon these stones a waterproof covering, over which earth was placed in sufficient quantities to provide for the roots of trees and shrubs planted there and watered by means of small conduits connected with a reservoir on the upper terrace. Every kind of tree and plant that could give pleasure by its beauty or fruit was brought from Persia, Armenia, Greece, Egypt and India. Within the terraces were magnificent apartments and banqueting rooms, with walls of glazed brick, colored blue, red and yellow, and amid the groves were fountains and seats.

*W. H. M.*

Go, make thy garden fair as thou canst,  
Thou workest never alone,  
Perchance he whose plot is next to thine  
Will see it and mend his own.

*Robert Collyer.*



### The Riverside Cemetery of Norristown, Pa.

The Riverside Cemetery is most beautifully situated on the banks of the Schuylkill River about



VIEW IN RIVERSIDE FROM ENTRANCE.

one mile above Norristown; hence the name Riverside.

As is seen from the picture taken from the entrance a splendid view is obtained of the Chester Valley, which meets the Schuylkill Valley on the opposite side of the river from the cemetery.

To the left of the same picture a glimpse of the Schuylkill River is to be seen.

No more ideal spot for a cemetery could be found. The land being high and dry, very picturesquely situated, and from the rolling nature of the ground perfect drainage is obtained.

The accompanying views will illustrate what can be done in a comparatively short time with very little capital, judiciously expended. The views were taken about two years from the time ground was first broken for cemetery purposes, but the improvements were completed in about eight months.

The Cemetery Company own and control about fifty acres of land, twenty-five of which is enclosed and improved. The total amount of capital originally expended was \$20,000, of which sum \$10,000 was spent in purchasing the twenty-five acres clear of encumbrance, \$8,000 for permanent improvements, \$1,000 for building the approach to the grounds and \$1,000 for securing other land for future enlargement.

As stated before the ground is gently rolling, with a ravine on the eastern side in which a miniature lake has been constructed.

The avenues are built on the Telford-Macadam principle; the bottom stone being quarried on the grounds, while fine crushed bastard marble was purchased for the top dressing, the light color mak-

ing a finer contrast with the surrounding lawns than the stone obtained on the grounds.

The cemetery is managed strictly on the landscape lawn plan. No enclosures of any kind are allowed. Corner stones are set flush with the ground and grave markers must not exceed twelve inches in height.

The management reserves the right to reject any monumental work that they consider detrimental to the cemetery. Not more than one monument is allowed to each lot, and one stone to each grave. All work on the grounds must be done by the employes of the cemetery. A comfortable waiting room with superintendent's office attached is provided for visitors.

The cemetery also has a small receiving tomb for which no charge is made to lot holders in the winter months. But it is seldom used as the Norristown public prefer to bury their dead in the winter if it is any way possible. The cemetery also furnishes a tent and matting free of charge to protect the mourners from the rain and sun.

Compared with what the citizens of Norristown have been used to, the manner of conducting Riverside is a radical change. The cemetery is popular. In the older cemeteries about eighty per cent of the lots are enclosed with a fence of some kind.

The average yearly death rate for Norristown is four hundred and fifty, of which Riverside has so far averaged sixty; there being one hundred and forty-five interments for the first twenty-nine months. The balance is distributed among three old cemeteries of from thirty to fifty-five years' standing, not mentioning the numerous church yards that still have occasional burials. A most important



VIEW IN RIVERSIDE.

feature of the Riverside Cemetery is the perpetual care given to all lots and graves. To insure this a permanent fund is being created by placing



ten per cent. of the receipts from the sale of lots with the Norristown Title, Trust and Safe Deposit Company. To insure the fund being used for the purpose intended the by-laws have been so framed that this trust cannot be altered without the consent of the lot holders.

The landscape work has been entirely in the hands of the superintendent, Bellett Lawson, Jr., who has been allowed by the directors to use his individual taste throughout.

Riverside Cemetery is a striking example of what can be done in a small town with a very conservative people.

---

#### Hybrid Species.

##### PRINCIPLES AND LAWS OF INTER-BREEDING OF PLANT LIFE.

When a plant is raised from seed it will always bear a strong likeness to its parent, and if the species be one which has little tendency to variation it will resemble it very closely. But there are many species which have a great disposition to present deviation from what may be considered their original form, and thus from seeds of the same parent it is often possible to produce by a difference of treatment a number of plants differing considerably from one another.

Whatever such difference may be, however, these plants are all regarded as belonging to the same species, since they are descended from a common stock, and by such experiments it is often possible to show that plants which have been considered as distinct species have no real title to be so classed.

It is often possible, however, to produce seeds capable of giving origin to plants that shall combine the characters of two different races. This is done by placing the pollen of one species upon the stigma of another, so that the germ furnished to one shall be nursed by the other. It is not difficult to understand how the germ thus influenced should be subsequently developed into a form differing from that of its own parent, for the genus of cryptogamia, which are not received into any ovide, but are dependent upon elements alone for their support, are often developed, especially among the lower tribes, into forms very different from that which they would naturally present.

Thus a mucor, a sort of fungus concerned in the production of moldiness, has been seen growing in water in a form so like that of a conifer that it was only recognized as a fungus when it lifted up its fructification above the field.

The plant developed from a seed by the agency of two races is termed a hybrid.

It is necessary in order that the seeds thus formed should be fertile that the parent species

should be nearly allied to each other, and it is very seldom that a hybrid can be produced when they do not belong to the same genus. Now, if the hybrid bear flowers and its stigma be fertilized with its own pollen it may produce seeds that can be raised into plants like itself, and these may flower and produce a third generation in like manner.

But there is no instance in which a hybrid race (and this applies to the animal, as well as the vegetable creation), which has thus originated in the intermixture of two species really distinct, has ever been continued without intermixture beyond the fourth or fifth generation. The plant, when not fertile by itself, may bear seed if its stigma be sprinkled with the pollen of one of its parent species, and its pollen may be fertile when placed on the stigma of either of these.

In this manner a race intermediate between the hybrid and one of the parent species is produced, and this is continued longer just in proportion as it is caused to approach the pure breed by a successive intermixture of this kind. The end of all hybrid races produced between races really distinct appears to be, therefore, that either the race becomes soon extinct, which it will do if kept separate, or it merges into one of the parent races, if continued by intermixture with either of them. This principle affords a valuable test for determining what really are and what are not distinct species, for if a hybrid race can be produced between them which continues to be fertile of itself the probability is strong that they are only varieties.

Cultivators of flowers are constantly in the habit of producing such new races between the different varieties of many plants.

For instance, the South American amaryllis and the calceolaria. Both these species are very much disposed to spontaneous variation, and by selecting the most beautiful of the new races that spontaneously originate from their seed and causing them to produce hybrids a still larger amount of variety, both in form and color, may be obtained. These hybrids are of equal fertility with their parents, since the latter are not separated by any essential difference.

*Andrew H. Ward.*

---

In the royal gardens at Kew there is a branch of what is said to be the oldest tree in the world—the famous dragon tree (*Dracaena draco*) of Oratava. This tree, which was destroyed by a great gale some years ago, was, the new weekly paper the *Rocket* says, supposed to be at least 2,000 or 3,000 years old—some assigned it a much longer growth. A branch was removed from it and brought to Kew, where it still thrives; it may be seen in the Economic house.—*Westminster Gazette.*



**Kentucky Notes.**

The most remarkable man that ever lived is buried in the Lexington Cemetery, if the epitaph on the monument of Richard Higgins is to be credited. It is:

"The man of 73 years who never made an enemy or lost a friend."

The management of Cave Hill Cemetery offered a prize of \$25.00 at the Louisville flower show held in November '96, for the best design for a carpet bed, in the hope of obtaining something new and unique. In some quarters this action would be accounted a clear case of encouraging evil doing.

Among the substantial monuments in Lexington Cemetery is the Stone memorial, an excellent example of Westerly granite. It is peculiar in that it bears the name of a dog below that of the master. The little animal is interred in the family lot and has a head stone which is lettered thus:

In loving memory of Don  
For sixteen years our silent brother and best friend.  
"His faithful dog shall bear him company."

Two stained glass windows in the chapel of Lexington cemetery are memorials to two of the early Presidents of the Cemetery Board, one a lawyer, the other a business man. The windows are supposed to symbolize law and commerce, but their artistic merit is not visible and the designer's ideas of law and commerce seem to have been rather hazy, for the symbols are so mixed as to be confusing. In fact after laboriously singling out commerce I learned it was the memorial to the dead Jurist.

A monument in Lexington cemetery bears this inscription:

Lt. Hugh McKee, U. S. N.  
Killed in leading an attack upon the forts of Corea by U. S. Naval forces in 1871 where the citadel has been named Ft. McKee in his honor.

This officer's father died on the battlefield of Buena Vista and is buried with other Kentuckian's who fell in the Mexican war, on the state lot in the Frankfort, Ky., Cemetery.

Both white and black ducks have heretofore enlivened the lake in Cave Hill Cemetery but in '95 the black ones were banished because they devoured all of the hen and chicken plants they could find in the carpet beds. And now the white ones have developed the same taste. Probably the water fowl resented the use of such non-aquatic material.

The extremely substantial memorial to Mrs. Bell, the wife of the superintendent of Lexington cemetery, is of gray granite from the south of Scotland. The lettering on it is peculiar, looking as though put on with—black paint, but in fact the letters are deeply dovetailed, filled with lead and

then polished. The work is said to be very durable.

At the head of the space reserved on the family plot for the grave of the superintendent of Lexington cemetery stands a shapely Box tree. Mr. Bell looks on it as his own monument.

The Morgan family plot in Lexington cemetery is shaded by a very old gnarled and picturesque weeping Ash. Its twisted arms seem to be writhing in unnatural agony. John Morgan the famous confederate raider lies next to his mother, at whose grave a white Jessamine is planted and bears all through the warm season its fragrant, star-like white blossoms. The subject of moving the remains of Morgan to another lot, and erecting a monument to his memory, is being considered by the Veterans of his old command.

*Lonicera fragrantissima* is used for a hedge several hundred feet long at Ashland the historic home of Henry Clay which lies along the Richmond pike about one mile east of Lexington. It makes an attractive hedge bearing a heavy crop of fragrant white flowers in spring, remaining fresh and pleasing in foliage through the summer and retaining its leaves all winter as it is evergreen in this latitude, the young leaves appear at about the blossoming season.

*Fanny Copley Seavey.*

**The Old Church, Bonchurch, Isle of Wight, England.**

When meditating a trip to England in 1895 the publisher of PARK AND CEMETERY asked me to keep in mind that anything I might see that would be of interest to the readers of the paper would be very acceptable. There were many places seen by me of which notes were made, but of which photographs could not be had at the time. Through the kindness of some good friends I have lately received some of the photographs desired, and propose to use them from time to time. Two of them are presented herewith, one of the old church, Bonchurch, the other of a noted grave in the new church, called "The Shadow of the Cross." Bonchurch itself is close to the sea, on the South-eastern shore of the Isle of Wight. The broad expanse of the English Channel divides it from France, the distance between the Island and Cherbourg being about sixty miles. The island at Bonchurch and vicinity presents to the sea immense cliffs, and back of these are the towering downs, as they are called, one of them known as St. Boniface Down, which is immediately back of the town, is of 787 feet elevation, and its rise almost perpendicular. It is at the foot of this Down, on its Eastern slope, that the old church stands. What with the steep elevation





trees overlap it. In this churchyard is a grave called "The Shadow of the Cross" to which the attention of visitors is called. It contains the remains of Ellen Gladys, a daughter of Lieut. Gen. Byam. It is called the *Shadow of the Cross* because the cross which is prostrate and slightly elevated above the grave, throws a perpetual shadow on it, even when the sun is not shining. It was a beautiful thought which led to the work. It is a pleasure to be able to present a representation of the grave and cross. The words on the arm of the erect cross are "With Christ, which is Far Better." In this churchyard there are many natural

back of it and the mass of verdure afforded by the trees, it is almost hidden from sight. A situation more fitted for a resting place for the dead could not possibly be conceived. So solemn, silent, yet beautiful withal was the scene, with the sound of murmuring waves on the shore, that involuntarily came to my mind these lines from the "Bivouac of the Dead."

"Rest on endeared and sainted dead,  
Dear-as the blood ye gave;  
No impious footstep here shall tread  
The herbage of your grave."

It seemed to me that a church more prettily situated I never saw, and I think your readers will agree with me in my opinion. The embowering trees and the partly ivy covered roof are seen in the picture, but not the many beautiful flowers with which many of the graves were adorned.

There are two churches at Bonchurch, the old one, as illustrated here, and what is called the New Church. This, the old church, is now only used at funerals. This little cross surmounted edifice is supposed to have been built 800 years ago, and in this vicinity it is supposed the first Christian missionaries landed.

The new church is a little higher up the hill, above the old one. It was erected by public subscription, the foundation stone being laid in 1847. The then rector was the Rev. William Adams, an author of some note. Some of his works still held in high esteem are "The Shadow of the Cross," "The Distant Hills," "The King's Messengers" and "The Old Man's Home." As with the old church, it is beautifully situated. Its northern boundary is an almost perpendicular wall of rock, but the rocks are vine clad and the branches of

boulders of small size, and these were all vine clad. Many graves were between these boulders, and it was a pleasure to see the blooming roses and fragrant flowers on every side. Besides the natural growth of oak, elm and ash, there were cedar of Lebanon and Sequoia gigantea which had been planted, and the whole place was more like some beautiful garden than a church and churchyard as usually seen. True, it was the last day of June when I saw it, when all nature is at its best. It gave me a great deal of pleasure to see the affection of many who had laid their dear



THE SHADOW OF THE CROSS.



ones in this lovely resting place of the dead. On one grave, placed among some boulders near the entrance gate, there had been fresh flowers placed that very day, although, as the record showed, the interment had been made six years previous. This is, of course, nothing more than is seen in almost any cemetery any day, but a good deal of pains had been taken on this one. The offering was in the shape of two crosses, made of the bark of trees, with hollow centres, which were filled with loveliest cut roses. And the little crosses of blue lobelia seen here and there, and the tasteful arrangement of nature and art everywhere visible, led one to believe he was in some secluded garden.

*Joseph Meehan.*

---

### Water Lilies.

#### SELECTION OF VARIETIES.

The sterling worth of these lovely flowers has steadily appreciated in all the departments of esthetic and essential horticulture since their first introduction until to-day they have more and warmer friends than any other of the aristocratic classes of plants, orchids not excepted, in America.

Those familiar with the various kinds of water lilies are very careful in the selection of varieties adopted to the purpose for which they are intended, and for the inexperienced a word of caution is not out of place. For lack of due consideration in this respect, the labors of many amateurs have resulted in failure and censure was at once thrown upon the plants or the florist, the real cause not being known. Just so one possessed a water lily it was thought sufficient, not knowing that there is as wide a difference between the inferior and finer sorts of water lillies as there is between the common wild or old time annual roses and the up-to-date teas. Their qualities are wholly unlike. Some are annuals—some ever blooming—some are tropical—some temperate—some hardy. Some are very free bloomers while others are shy. And then while water lilies are wonderfully alike in general habits and culture, it is well enough to study the special quality of each plant in order to obtain perfect results. For example some varieties are at home in tubs or small tanks, but worthless in ponds, while others, refusing to be cultivated, do best in natural ponds. Some varieties are highly valuable as fish forage but of no importance for ornament and with others the reverse is true.

No general advice that I know of is better than this—if you anticipate planting water lilies and are not familiar with them, consult some one who is. Consider the location and the effect desired, that is,

whether for economical or ornamental, or both. If ornamental, whether specimen plants or general effect is desired. It is a good plan to look over the catalogues through the long winter months, and read as well the experience of others in the horticultural journals, then by spring time you will know more definitely what is wanted.

After a judicious selection of varieties there is no other class of plants to be found with which culture is so simple or success so eminent.

*Geo. B. Moulder.*

---

### Water Plants as Land Makers.

One of the earliest surprises of the writer, on a botanical collecting trip, was to enter a wildwood on a beaten path, and on returning find a stream of some 20 feet wide and of unknown depth right across that path. It was his first experience with a floating island. The wind had changed, and blew the island to the opposite shore! When sand enough would be collected from the winds, possibly the island would sink, and then logs would be found beneath the surface, as White Cedar logs are now found below the surface in the bogs of New Jersey. How plants prepare the way for such growths, we have often had illustrated. "Captain W. A. Shaw," says a Jacksonville, Florida, paper of recent date, "of the St. Johns River steamer Everglade, says that he has never seen anything like the quantity of hyacinths as now float in the river between Palatka and Astor, and he has been in command of a steamer on the river for more than a quarter of a century.

Palatka is the worse choked up point on the river, as acres of the water vegetable cover the surface of the river, and to get through it with the steamer is a hard job. The wheels become clogged, the bow banked against and it is going ahead and backing for hours at a time to make a passage.

Not only is the river obstructed, but also all the creeks between Jacksonville and Palatka.

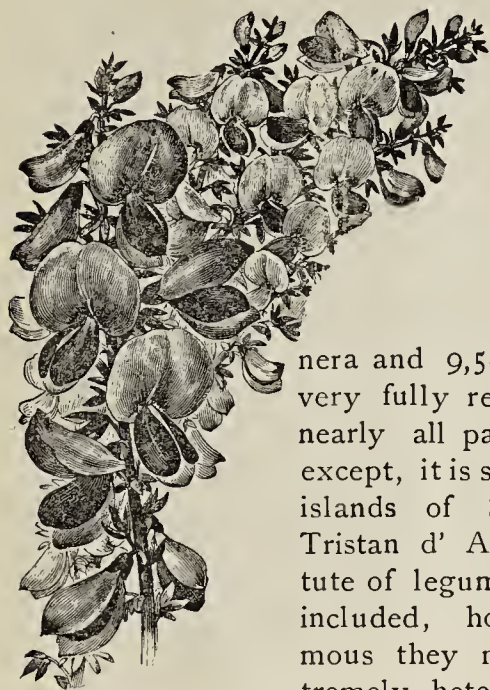
Only for the river traffic, these water plants would be undisturbed, and in the end, dust and sand would grow moss and similar low orders of vegetation. On these, seeds of grasses and larger plants would be borne by birds and by the wind and, rotting, form a thick, peaty surface. Then come tree seeds, and the young forest, in time, sinking by its own weight. But the process again renewed from time to time, the whole would be filled up, and a deep peat bed formed, and real land appear in due time. Yes, water plants as well as all things have an appointed mission to fulfill.—*Meehans' Monthly for January.*



## Garden Plants, Their Geography, XIV.

## ROSALES (A.)

## THE GENISTA, ROSA AND DROSERA ALLIANCE.

CYTISUS SCOPARIUS.  
VAR. ANDREANUS.

This group as it is constructed by botanists is one of the largest in the vegetable kingdom, containing no less than 47 tribes, 666 genera and 9,589 species. It is very fully represented too in nearly all parts of the world, except, it is said, that the small islands of St. Helena and Tristan d' Acugna, are destitute of legumes. The species included, however homogamous they may be, are extremely heterogeneous in aspect, and so numerous that close selection becomes imperative for garden purposes. In arranging on the ground the mass of material is found so unwieldy that it is usually necessary to break the planting into semi-detached groups. None of the alliances are more fully represented in trees, shrubs and herbs, none are more beautiful in all sections, and but few are so full of plants useful to man.

The determination of scientists has rested largely, I believe, upon the amygdaloid embryos, and these are often microscopical. It is a question if it would not often be better to seize upon more obvious characters. The papilionaceous flower, or leguminous fruit is pretty sure to obtain through nearly 9,000 of the species, a number sufficiently large and important to constitute an alliance, and upon the whole they seem sufficiently distinct from the bulk of rose flowers proper. I have never been able to see with the naked eye any great resemblance twixt a strawberry and a bean, or between a Kentucky coffee tree and a sedum. Yet, they are forced into the same alliance, and it must often perplex the tyro to know why. Microscopical investigation is impossible to the mass of mankind, and impracticable for most gardeners, who, though often willing enough to take the dicta of eminent investigators on trust, will often feel a shock to their understanding when they find the honey locust and the sundew grouped under the name of the rose. It does too much violence to the common understanding.

I am led to these remarks by the very immensity of the Rosal Alliance, as well as by the diversity of the species.

Nothing short of a woodland and an immense garden in departments could accommodate a fair representation of the tribes, and even for purposes of pure ornament and instruction, with the closest selection of species and varieties, their claims to recognition are so pressing, especially in the woody sections, that for garden purposes and the exigencies of embellishment it nearly always becomes necessary to break them into separate groups. The New York Botanical Gardens largely run to quarter million buildings, but the tender plants, their raw products and manufactures would fill them, and the 45 acre Arboretum would fail to ornamentally accommodate the hardy Rosales.

The dictamen of the botanists has been spread over the earth, however, and it is not well to change it; topsy-turvy classification is especially confusing, otherwise I could wish that for garden purposes Rosales could be divided into (a.) Legumales; (b.) Rosales proper, and (c.) Saxifragales.

The alliance commences with two tribes, *Connareæ* and *Cnestideæ*, having about 170 species distributed over the tropical regions; none are nearer to the United States than Central America.

*Piptanthus Nepalensis* is a monotypic genus from the Himalayas; it is known as the evergreen laburnum, and should be tried at the south.

VIGNA STROBILOPHORA. (*Garden ana Forest.*)

*Thermopsis* has thirteen species in Eastern and Northern Asia and in North America, mostly from



western and southern points. They are summer flowering herbs.

*Baptisia* has fourteen species, with yellow, blue or white flowers. All are North American. A large number of species of *Brachysema*, *Oxylobium*, *Chorizema*, *Gompholobium*, *Daviesia*, *Gastrolobium*, *Pultenæa*, *Dillwynia*, etc., belong to the same tribe, many of which will no doubt succeed well in Southern California.

*Lupinus* has ninety-five species from North America, the regions of the Mediterranean and tropical Africa. The various sections of the genus yield many handsome perennial and annual species. Our botanists enumerate more than seventy forms, including *L. arboreus* from California and *L. perennis* from South Jersey.

*Laburnum* has three species and a number of varieties natives of the south of Europe and Asia-Minor. They are hardy enough to grow up from seed in garden ground in Britain, where they form beautiful trees of from fifteen to thirty-five feet high. In this country it seems strange that they appear to do best northwards, the finest I have seen being at Canandaigua, N. Y. South of New York City they are stunted in appearance, but still well worth growing. Most likely hygrometrical conditions determine their well being.

*Genista* is a larger genus of seventy species, European, North African and from Western Asia. Three species are credited to Britain, two of them quite frequent, but *G. pilosa* is less common, being confined to Suffolk and parts of the west coast. *G. tinctoria* is the "green weed" naturalized in various parts of New England, New York, etc. *G. Anglica* appears to be the name fully settled upon the "petty whin." There is great confusion in the names of this and the following genera in catalogues. *Ulex*, "furze," has ten or twelve described forms. About four or five are in cultivation, *U. Europæus* and its handsome double form being most common. I have sometimes been told that the furze has become naturalized in South Virginia, but no mention of it occurs in the Botanies. It is tender at Washington. *Cytisus*, "broom," has forty species, mostly from the countries bordering the Mediterranean and in the Canary Islands. *C. Scoparius* is the "Scotch broom" naturalized from Virginia southwards and hardy in New Jersey under the shelter of trees or buildings. It is this plant and not the green weed that gave the name *Planta-genet* to the Norman race of English kings. Geoffrey d'Anjou, father of Henry II., wore it in his cap. It is to-day claimed as the badge of the Culloden Forbes. As nearly as I can make it, out of all the confusion, *Cytisus albus* is now the settled name of the beautiful white "Por-

tugal broom." It also ought to be adapted to the country south of the Carolinas, as it stands all ordinary British winters. It has a pink variety. *C. Andreanus* is a form (a chance seedling) of the Scotch broom, but has been sold often for a *Genista*. *C. nigricans* and others have lived over northern winters sometimes, and many would succeed in California. These plants are practically evergreen (in color) and it seems strange that they are so seldom seen in small gardens.

*Ononis*, "rest harrow," is in sixty species, natives of Europe, Western Asia and North Africa. They are often beautiful suffruticose or annual plants, with purple, pink, yellow or more rarely white flowers. It might be expected the British *O. arvensis* and *O. spinosa* would have naturalized southwards, but I have not seen them recorded. *O. Aragonensis* from the Pyrenees, *O. arborea* and *O. rotundifolius* from the south of Europe and *O. natrix* from further north are in European gardens, and I think McMahon mentioned some of them as hardy at Philadelphia ninety years ago.

*Trigonella*, "fenugreek," has sixty species in Europe, Asia and South Africa.

*Medicago* is a genus of forty species from Europe, Asia and Africa. The "Lucerne," *M. sativa*, is a valuable fodder plant, especially on dry, warm calcareous soils. It has been in cultivation from time immemorial and is well known on the Pacific coast as "Alfalfa." There is a variety or two, one with yellow and purple flowers. The six or seven British perennials and annuals are sometimes admitted to gardens as much perhaps for their curious twisted pods as for their purple or yellow flowers. They enjoy a number of popular names, such as "snails," "caterpillars," "burs," "sickles" and so on. Several are naturalized in the United States. *M. arborea* is an evergreen shrub from Southern Europe, growing to 8 or 10 feet high. Evergreen shrubs, except for the far south, are uncommon in the alliance.

*Melilotus*, with ten species, and *Trifolium*, with 300, are the sweet and common clovers respectively. Both are distributed over the four continents. A few are ornamental.

*Anthyllis*, "kidney vetch," has twenty species, natives of Europe, Western Asia and North Africa. They are annual or perennial herbs or evergreen, low growing shrubs. Some of the latter may be of use for the gardens of the upper south. *A. Barba-jovis* grows to six or eight feet, with silvery leaves and yellow flowers. *A. Hernianniæ*, also yellow flowered, is from the Island of Corsica and hardy in the south of England. *A. cytisoides* has white flowers and *A. erinacea*, purple.

Trenton, N. J.

James MacPherson.





BRICK ROADWAY, MONMOUTH, ILL.,

#### Brick Roadways.

Brick is a material perhaps never considered at all in dealing with park and cemetery roadways, but it is one which is nevertheless growing in importance as rapidly as the knowledge of its availability and adaptability is developed. Of late years much attention has been given to the work of making bricks suitable for road construction, and all the details of their manufacture, and the composition of the clays entering into their production for the purposes required, have been made a subject of special investigation and scientific research.

While not the ideal roadway, for which it may be said we are still seeking, roadways constructed of the proper quality of paving bricks have proved both durable and permanent, and from the nature of the material of easy repair, as well as presenting a goodly appearance.

In considering the question, it would really seem as though brick roadways would be well adapted to the approaches and boundary roads of our cemeteries, especially commendable for cleanliness and permanence, and such roads would materially add to the external appearance, which unfortunately is now too often neglected.

The view given herewith for the use of which we are indebted to *Brick*, is one of several taken about Monmouth, Ill., by the *Monmouth Daily Review*, to whose efforts, the town is largely indebted for its successful use of paving brick in improving a country roadway.

The road was constructed as follows: the road-

way to be operated upon was graded and allowed to stand sometime, with an occasional scraping, to even it up and make a hard and dry bed upon which to lay the surfacing. Curbing of 2 in. by 6 in., oak plank was then set 7 feet apart and held in place by oak stakes driven 4 feet apart. A five inch bed of sand was then spread and compacted evenly between the curbs and on this a single course of paving brick set on edge was laid. Outside the curbs a two foot width of crushed stone was used, graded up to the brick, and the rest of the earth road graded up to this, making a good roadway all over in dry weather. The total cost of this brick and stone combination roadway was 90 cents a running foot.

Drainage is effected by tile drains which are not necessary on high ground, as the water rapidly runs off the brick surface. The people of Monmouth are gratified over the success of this new era of country road building.

The road question is a very important one throughout the country districts. It is an economic question, and although one which can be proved by figures to make immediate returns, the first cost of any complete system, either for township or country, for the time being, obscures the ultimate benefits. Such improvements however should be very favorably received by cemetery corporations, for in these directions lie the readiest avenues to public approbation and hence to the successful operation of well conducted cemeteries in all sections of the country.





THE URI BALCOM MONUMENT, OAKWOODS CEMETERY, CHICAGO.

**THE URI BALCOM MONUMENT, OAKWOODS CEMETERY, CHICAGO.**

Of the many attractive memorials that have been erected in Oakwoods Cemetery, Chicago, during the past year probably none will command more attention of the visitors to those beautiful grounds than the monument illustrated above.

It is in memory of the late Mr. Uri Balcom, who for many years was a well-known citizen of Chicago, and it occupies a commanding site in one of the aristocratic sections of Oakwoods, surrounded by many costly examples of monumental art.

Before Mr. Balcom's death he had quite an expensive coping of Minnesota granite placed around the grounds of his residence, and so well pleased was he with the general effect of it that he determined to have the same material used for his monument, which in accordance with his will should mark his final resting place.

The granite used for the upper sections and bases and capitals of the columns came from the Rockville quarries, Minnesota. It is of a dark reddish brown color, unevenly mottled and susceptible of an exceedingly high polish. The columns are of a red-

dish colored Wisconsin granite that harmonizes with the Minnesota granite, and which like the balance of the monument are highly polished.

The principal dimensions of the structure are not without interest, some of the sections being of uncommon size. The first and second bases are cut together with joint running lengthwise; the bottom base is 17 ft. by 13 ft. 6 in. and with the second base is 1 foot thick; third base, 11 ft. 9 in. by 8 ft. 3 in. by 6 in. The columns, ten in number, are 1 foot in diameter and 7 ft. 3 in. in height; column capitals, 1 ft. 6 in. by 7 in.; architrave, 11 ft. 6 in. by 8 ft. by 1 ft. 4 in.; cornice, 12 ft. 6 in. by 9 ft. by 2 ft. 3 in.; the entire height of the monument is 14 feet, and it weighs nearly seventy tons. The inscriptions are placed on the third base, over the vault. The family name in front and back of frieze and year at either end are cut in ten-inch V letters. The bodies of Mr. and Mrs. Balcom rest in a hermetically sealed vault, under the third base, and no other additions are to be made.

The general appearance of the monument is very satisfactory. It was built by the J. H. Anderson Granite Company of Chicago.



**Glass Bricks in Horticultural Buildings.**

Visitors to the Chicago Exposition will remember the little building exhibited by M. Falconiere to show the method of using glass bricks for the construction of fern houses and houses for other shade loving plants. One of your correspondents afterwards pointed out the immense structural possibilities afforded by this material if employed in architectural designs of a suitable kind. M. Falconiere seems to be impressed with the same idea as is shown in the *Scientific American* of January 2.

This little structure is certainly much more suggestive than was that of the World's Fair. Really, however, the true province of the glass brick seems to be to relieve the barn-like ugliness of the conservatories. If it were used in conjunction with iron in much the same manner as brick or other material is used in the skyscrapers there is no limit to the gracefulness and variety of outline that the conservatory might assume. Eastern architecture would be most profitably studied because it combines the greatest variety of form combined with the low roofs essential to economy of heating. Many of the magnificent mausoleums of Futtepore and Agra are especially rich in their combinations of exquisite domes surmounting low ranges of hip and gable-roofed structures of extreme lightness and beauty. There is danger, of course, that such architecture might be prostituted in the hands of the unskilled and tasteless, but there are indications that M. Falconiere is alive to these forms. Something has been said as to color, and green seems to have been a preference for the coloring of glass thus far. If the coloring material is good and the glass is not subject to become reddish it has a handsome appearance and, except in dull climates, is beneficial to shade loving plants. Another beautiful shade of color for hothouses is light blue and white. These were the colors employed by Sir Joseph Paxton at the Crystal Palace, London. Once properly appreciated, we feel sure there is a great future in store for these glass bricks, not alone in the forms they may produce, but in economy, durability and the equalization of heat and moisture. For the lining of dairies and buildings requiring dryness they should also be of service, but we can conceive some clever architect in conjunction with a skilled gardener producing a building by the aid of this material and iron as famous for beauty of outline as the Taj-Mahal.

**Cave Hill Cemetery, Louisville, Ky.**

Through ignorance of financial matters a glaring error regarding the standing of the Cave Hill Cemetery Co., crept into my description of that interesting cemetery in the December issue of PARK

AND CEMETERY. The statement of its condition should have read thus:

"The perpetuity of the cemetery is insured by a fund created by paying over to the Cave Hill Investment Co., one-tenth of the proceeds of the sale of all lots until the fund shall have amounted to \$200,000. This fund is managed by the Cave Hill Investment Co., chartered in 1882, and is to be held and applied to the preservation and ornamentation of the grounds. The income from it is to be reinvested, and no part of it used, except for the necessary expenses of the company, until eight-tenths of the lots are sold, or until the par value of the fund shall equal \$200,000. Then the income may be paid over to the managers of the cemetery to be used by them in caring for the grounds."

Cemetery officials will, of course, understand from this that the fund held by the Cave Hill Investment Co., has not yet reached \$200,000.

The fact is that instead of receiving interest from that company the Cemetery Co., pays several hundred dollars each month into the fund.

The article also gave a wrong impression regarding native forest trees, as a part of the grounds contain many noble specimens of numerous species—only a part of the enclosure having been denuded of its indigenous growth by the soldiers encamped in the grounds during the war.

And the cemetery was laid out by David Ross, the first superintendent, and merely platted by Benjamin Grove.

To make the account accurate to the last degree I note the obviously erroneous wording as to the largest *section* having an area of 2,500 square feet—that being the size of the largest *lot*.

Regret for these errors would be deeper did not their correction serve to call further attention to a cemetery well worth a visit from every cemetery official in the country. F. C. S.

**Clergymen Aiding in Modernizing Cemeteries.**

The Rev. Mr. Purdy, an Episcopal minister from Minneapolis, after an absence of 10 years from a former pastorate was called upon to re-visit the scenes of his old charge to officiate at the funeral of one of his former parishioners. The numerous changes that time had wrought were to him too apparent. But more especially was he impressed with the improvements made in the old time cemetery, where some of his dear family were at rest. The following Sunday he addressed the members of his old church, the subject of his address being "The old Pioneers and the Cemetery." Remarking how many vacancies there were among the once familiar faces of his friends, so many of whom



were taking their rest in the cemetery, he told his hearers how the pioneers had first constructed the place to the best of their ability, and as years went by, the grounds were developed, till now skillful hands had created wonderful improvements. Nature had been bountiful in supplying a beautiful location, but man's ingenuity had indeed so improved the spot as to be hardly short of marvelous and the citizens should feel proud of being possessed of such a burial place. It was gratifying to himself to know that after his earthly career had been run, that he would be laid away in so lovely a place. He pointed out that it was the duty of all to aid the officers in the well being and proper conducting of the cemetery.

This eulogy gave the writer a subject for thought. Why should not the ministers of the different churches aid in raising to a proper standard the management of our country burial grounds. No persons have such opportunities for witnessing their too frequently neglected condition. If the Cemetery Superintendents' Association could enlist the aid of the clergy and induce them to point out to their congregations that in no place was cleanliness more akin to godliness than in the final resting place of our dead, they could stir up their hearers in a manner that no others could. The seed sown would surely bear good fruit.

"God's Acre," in the great majority of our burial grounds, what a misnomer! Stir the people up, good sirs; stir them up.

---

#### Legal.

##### EXCHANGE SUSTAINED.

Where the stock of a cemetery company is almost without any market value the Court of Errors and Appeals of New Jersey holds that its exchange for an interest in land that may prevent disastrous competition is not so improvident as to shock the conscience, and lead in equity to an invalidation of the sale. In fact, the court pronounces such a deal beyond reasonable criticism. In reaching this conclusion it reverses a decision of the Court of Chancery, from which appeal had been taken, and wherein the chancellor had come to the conclusion that the sale, or exchange, was effectuated by the directors to secure a continuance of their official positions.

##### VALIDITY OF ORDINANCE PROHIBITING SALE OF CEMETERY LOTS.

"Whereas, the unlimited burial of the dead within the city and county of San Francisco is dangerous to life and detrimental to the public health; and, whereas, the right of those persons or associations who have already purchased lots or plots for their own use or for the use of their families or members

in the cemeteries in the city and county of San Francisco should be recognized," an ordinance goes on to provide that it shall be unlawful after the passage of this order to purchase, acquire, sell, lease or dispose of any land situated within the city and county of San Francisco for burial purposes. Nor shall any interment be made except in such lots or plots as may have been already purchased by persons, associations or corporations for their own use, or the use of their families or members; provided, the said lots shall not be used for general interment purposes. The effect of the foregoing ordinance, it will be seen, was in no respect to prohibit burials, but simply to limit the right to those who had been fortunate enough to secure a lot therefor before the passage of the ordinance. This leads the Supreme Court of California to say in the case of "ex parte Bohen," December 17, 1896, that the fact that the "unlimited" burial of the dead within the city is "dangerous to life and detrimental to the public health" may be a sufficient reason for the enactment of an ordinance fixing a term after which such burials shall cease within certain portions of the city; but, while burials are permitted within a district, the privilege cannot be limited to one class of citizens and denied to another class within the same district. The right to prohibit burials within a certain district rests upon the proposition that any burial within that district is injurious to the public health. And an ordinance forbidding the burial of human bodies within the city, or upon any designated portion thereof, cannot be sustained if such burial be permitted upon other lots similarly situated. Nor can the owner of lands be restrained from selling them for the purpose of being used as a place of burial, or any other use which in the future may become deleterious to health, and for that reason be forbidden, but which is not forbidden at the time of the sale. So the court holds that, while it may be conceded that if the burial of a human body within the lot purchased therefor had been made by a valid ordinance, the burial of the human body within the lot would have been an offense for which Bohen, the president of the Odd Fellows' Cemetery Association, that sold the lot, might have been charged as an aider and abettor in executing the deed; yet, until the offense of such burial had been committed the sale and purchase of the lot could not be made the basis of a crime or misdemeanor. And as the ordinance in question by its terms, as well as by its operation, discriminates in its operation between individuals similarly situated the court holds that it is upon that ground unreasonable and invalid, and the petitioner, Bohen, who had been convicted of a violation thereof, should be discharged.



## PARK NOTES

Travis Phillips, ex-mayor of Aurora, Ill., who died in December last, has bequeathed to that city \$20,000 for the purchase of a public park.

\* \* \*

Point Pleasant Park, Halifax, N. S., is undergoing rapid improvements at the hands of a commission. The new lodge at the park entrance is about completed, and during the past three years 6,000 young trees, mostly Austrian pines, Norway spruces and maples, have been added to the forest portion of the park.

\* \* \*

The extension of the Yellowstone National Park is being seriously advocated for one reason—to afford territory for the protection of the game of that part of the country, which comes down into winter quarters. The government protects the game within the limits of the present park, but under existing conditions cannot effectually carry out the intent of the National Park in this particular beyond such limits.

\* \* \*

The proposed Semi-Centennial Exposition to be held in Milwaukee, upon the various sites for which, Mr. Warren H. Manning, landscape architect, of Boston, has made a report is meeting with serious setbacks. One of the latest is that the scheme is to be abandoned. Mr. Manning's report covered several proposed sites, which he took up in detail, and most strongly approved of that on the lake shore about the waterworks. Against the bluffs on this site he proposes an impressive structure on the idea of the "Hanging Gardens of Babylon."

\* \* \*

Enclosing the grounds of the photographer, Mr. F. Jay Haynes, at Mammoth Hot Springs, Yellowstone Park, is a fence made of elk horns. It contains over 300 selected elk horns, all of them having 12 points, and a great many the royal 14 points. They were shed in March, 1895, and were gathered in June of the same year within a radius of ten miles of Mammoth Hot Springs and within four days' time. There are about 2,500 elk in the park at present. Each pair of horns it is said would be worth \$7.50 at the railroad at Cinnabar, about eight miles distant, or at least \$10 a pair in the east or south.

\* \* \*

The annual report Dr. Geo. H. Stone, chairman of the Park and Tree Commission, Savannah, Ga., gives the public grounds under its control as follows: Forsyth park, 10 acres; parade ground, 21 acres; Colonial park, 5.9 acres; twenty-five squares, 21.8 acres; Tiny Thompson park, 4 acres; and Estill park 275 acres, making a total of 334.10 acres. The commission has control of all grass plats and trees. Its expenditures during the past year were \$12,027.02 exclusive of Estill park, upon which some \$914 were spent. The cyclone of September 29, did great damage to the trees, 639 being blown down and 2500 torn and twisted, among them many choice varieties. In the matter of trees the report says: "The care of trees is a subject to which the commission has devoted a great deal of thought. To select proper varieties for different places, to give to the flora of Savannah a distinct characteristic peculiar to this section, has been the frequent subject matter of discussion. We believe that the magnificent trio of evergreens, the majestic live oak, the grandiflora magnolia and the picturesque palmetto to be the distinct characteristic features of our flora and should appear in every point of vantage. We have a fine variety, each of which possesses many features to be commended, and it is the desire of the commission to so distribute them that they may enhance the beauty of the city, while holding to the main characteristic of this section." This is a commendable idea.

The Casino at Schenley Park, Pittsburg, Pa., which was burned last month, is to be rebuilt at a cost of \$500,000.

\* \* \*

The first annual meeting of the Tree Planting Association of New York City in which some two hundred members are enrolled was held last month in New York City, Mayor Strong presiding. Its object was to hear a progress report of Col. Mitchell and to discuss the question of beautifying New York's streets with trees. The difficulties of the work were appreciated. Col. Mitchell had investigated the question with the prominent nurserymen and had received offers to plant and maintain trees for two years at prices ranging from \$5 to \$22.50 per tree. The Norway Maple was recommended as the hardiest tree, and the one most likely to thrive in the downtown district. He recommended the formation of clubs in each locality for the purchase of trees and suggested that the children be taught to protect them.

\* \* \*

The main museum building of the Bronx Park Botanical Garden will be constructed on an elevation about 1,000 feet back from the Bedford Park railway station. It will have a frontage of 304 feet, a depth of 50, and two lateral wings of 200 feet in length. The horticultural building will be an equal distance from the station and the museum, and midway between them will be the heat and power house. A residence for the Director will be located on the easterly bank of the Bronx, while on the west side, within the limits of the main section of the garden, will be houses for the gardeners, propagating houses, stables, and rustic shelters. A second glass house or horticultural building is designed for the future, and the committee recommends a stone wall about the limits of the garden on all save the side at which it joins the rest of the park.

\* \* \*

At a conference recently held at Washington, D. C., in regard to setting aside public property for park purposes it was found that there had only been one enactment on the subject passed some twenty years ago. Under this had the beautiful improvements in Washington been prosecuted. It is found in the revised statutes, as applying to the district, and is as follows: "The proper authorities of the district are authorized to set apart from time to time, as parks, to be adorned with shade trees, walks, and inclosed with curbstones, not exceeding one-half the width of any and all avenues and streets in the city of Washington, leaving a roadway of not less than twenty-five feet in width in the center of said avenues and streets, or two such roadways, on each side of the park in the center of same; but such inclosures shall not be used for private purposes." The law is regarded as one of the most beneficent of those handed down from the old district municipalities.

\* \* \*

So far as the Essex County, N. J., comprehensive park system has been developed, it comprises one city park in Newark, a mile long; a small city park in a crowded section; a large stretch of meadow and woods and lake on the southern edge of the city; a high wooded peak with surrounding lands having a famous view of the Orange valley and the Passaic and Hackensack rivers; and a large tract of wild forest lands with little lakes, cataracts and hills. Besides this the commission proposes to boulevard a considerable mileage of country and village roads, and several other parks and a complete boulevard system is under discussion. Considering that but two years have elapsed since the commission was appointed by law, wonderful progress has been made in the preliminaries for so comprehensive a system. The commission has been overwhelmed with suggestions and advice, but it commenced its work under expert guidance and appears to have maintained itself in public favor by a wise and business like course of action.



## CEMETERY NOTES.

The directors of the Oakhill Cemetery Co., Ososso, Mich., contemplate the erection of a building, to serve also as an entrance to their cemetery, and other improvements to be undertaken the coming season.

\* \* \*

One of the finest crematoriums in the country is practically completed in Forest Home cemetery, Milwaukee, Wis., and eighteen cremations have already been carried out. Many of the most complete and successful crematories were visited and examined before details were finally decided for the above building.

\* \* \*

The annual report to the trustees of the Green Lawn Cemetery Association, Columbus, O., at their recent regular annual meeting show receipts for the year amounting to \$33,434.87, of which \$13,286 was derived from the sale of lots. The total disbursements were \$32,187.84, of which amount \$20,976.49 was paid for labor and \$1,900 for salaries. The association has \$114,305.48 invested in sundry securities.

\* \* \*

Interments may of necessity have to be stopped in Holy Cross Cemetery, Flatbush, Brooklyn, N. Y. It comprises about 145 acres, and was purchased about half a century ago. The first interment took place July 13, 1849, since which time over 200,000 burials have taken place. It is fast filling up, and no more adjacent property can be secured for extension. Although yielding a large revenue, it is only during the last few years that any improvements worth mentioning have been accomplished.

\* \* \*

The severe simplicity of the massive granite pillars and iron gates erected a year ago for the entrance of St. Agnes cemetery, Albany, N. Y., has been greatly relieved by the addition of an ornamental cross on the apex of each of the two large centre columns. The design was by Mr. John T. Gunson, architect, and the particular features are the fleur-de-lis terminals, that being the conventional emblem in art of the Virgin Mary. The board of trustees has decided to continue interments during the winter months, which will be appreciated by those to whom the second funeral is distressing.

\* \* \*

Probably the most important Bohemian cemetery in the country is the Bohemian National cemetery of Chicago. It is conducted on the mutual plan and comprises some 50 acres. Its perpetual care fund now amounts to \$15,000 and it is the intention to increase this to \$40,000 before using any of the interest. \$30,000 have been expended in improvements within the last year, which include a new entrance with office and waiting room, built of Bedford stone; office and greenhouse, and dwelling house for superintendent and sexton. There are about 1100 lot owners and 11,000 interments have been made. The six greenhouses cover an area of 135 feet by 96 feet. The water is supplied by an artesian well, and an ingenious method of watering the trees about the entrance has been adopted. When the rows of trees were set out, a gas pipe enclosure was constructed to protect them. This has been utilized for watering by attaching a supply, and putting outlets along the pipe opposite each tree. Much enterprise has been displayed in conducting the affairs of this cemetery, creditable to the management.

\* \* \*

Mrs. Basil Holmes in her book of "The London Burial Grounds," speaking of the multitude of monuments in Kensal Green, makes the following comments: "It is hardly possible to

appreciate such memorials when they are closely hedged in by others in all descriptions of stone of all styles and sizes, and in all styles of architecture. And it is appalling to think of the amount of money that has been spent on these massive monuments. How many a church or chapel might have been built in a growing district; how many a beautiful old church, now falling to decay, might have been restored; how many missionaries might have been sent to foreign lands; how many hospital beds might have been endowed; how many struggling families, or sick members of the same, might have been given a holiday in the country or by the sea; how many spaces might have been secured and laid out for the people; how many drinking fountains might have been erected; how many grants might have been made to voluntary schools or secular institutions for benefiting mankind; and how many objects of real beauty and antiquarian interest might have been preserved! It is impossible to give an answer to these questions—perhaps one would be sadder still if one could."

\* \* \*

A statement was left in writing by the late Countess of Wemyss, says the *Funeral Directors' Journal* of London, which should have an influence on funeral reform. "I particularly wish that no undertaker should have anything at all to do with the management beyond providing the coffin, which I desire should be made as plain as it is possible to make it. I wish the coffin to be laid on the frame of a farm-cart or lorry, covered over with a purple, or some colored, not black, so-called pall, and drawn by four horses, led by their own drivers, and I should like to be carried to the grave by such friends—workers on the estate—who are willing to do so. I hope that blinds will not be drawn down or crape worn, and that there will be as little outward signs of mourning as possible. I hope these wishes will not be looked upon as in any way eccentric. They are not so. They are simply the expression of a feeling that pomp and expenditure in funerals are unbecoming, and that death at the end of a long and happy life is more a matter of thankfulness and rejoicing than of lamentation or woe—

"Sleep after toyle, port after stormie seas,  
Ease after warre, death after life  
Doe greatly please."

\* \* \*

The annual report of the president of the Oakland Cemetery association, St. Paul, Minn., gives the net ordinary receipts \$20,803.25, and the net ordinary expenditures \$19,470.20, of which \$3,248 was spent for sewers and gutters. The principal of the Perpetual Care fund amounts to \$80,591.92 and the working fund is \$9662.25. \$87,700 is invested and draws interest. Among the details of Treasurers report, dated Oct. 31, 1896, are: Receipts from sales of lots, \$7338; single graves, \$1132; interment fees, \$1783; tomb fees, \$471.50; miscellaneous labor and foundations, \$1170.70. In expenditures, the pay rolls amounted to \$11,637.81; general improvement, trees, shrubs, etc., \$299; greenhouse, seed, stock and repairs, \$373.32; fuel, \$664.37. The receipts from greenhouse were \$3923.15. The superintendent's report shows that: there were 31,950 square feet of old ground regraded and sodded, and 4350 square feet of new ground. There were 36 monuments and 110 grave markers erected. Sixty lots and 91 single graves were sold, and the net area of land disposed of during the year was 10,575 square feet. The total number of interments to Oct. 31, 1896, including 296 during the year amounts to 12,630. The greenhouse affords interesting information; 88,645 plants of all kinds were grown, 25,495 being used to decorate lawns and 49,395 were planted on lots. The estimated value of greenhouse work for year, which includes plants for cemetery grounds and chapel, is \$5251.70 of which the \$3923.15 before mentioned were cash receipts. The average number of employes per month is 22.



**Microbes in Graves.**

The imaginative danger of spreading contagious diseases by germs in the earth, which is claimed by supporters of cremation cannot be proven, as has already been shown by Petri, Loesner publishes in *Medicini Moderni*, bacteriological experiments which prove assertions of Petri. According to this authority: Typhoid bacillus is lifeless in 96 days; the cholera bacillus as quickly as 28 days and the tubercular bacillus in 95 days.

Friedlander's Pneumo bacillus was lifeless in 28 days, while Tetanus bacillus was still in full vigor in 234 days, but found lifeless in 264 days. Splenic Fever bacillus seems to have the greatest vigor being found full of life after one year.

The usual earth filling of a grave forms a safe barrier against the penetrating of the bacillus; they thrive only for a short time in the corpse; traces of them could not even be detected in the earth below the grave bottom.—*Translated from the German.*

## ≡Correspondence.≡

**An Excellent Suggestion.**

TRENTON, N. J. Dec. 26, 1896.

*Editor Park and Cemetery.*

DEAR SIR: I should like to stir up the park superintendents to contribute of their knowledge to your columns more frequently. I should think that they would desire their experience recorded in such a magazine. Many excellent gardeners and other superintendents feel some shyness about writing, I know, yet, they are well aware that they have features in trees and plants well worth notice. If any such will send me photos of unusually fine named specimens, that I can use, especially from the extreme zones of cultivation,—north, south, or west to the Pacific, I will try to give standard names, and credit them to the senders, in my regular series of papers (if appropriate) or in separate ones. Anything not already figured will be acceptable. Notes as to age, height, spread, time of flowering, extremes of temperature where growing, and so on would be useful to record. There are so many amateur photographers nowadays, that it is possible to collect instructive data in a manner never before attainable, and there is no more worthy receptacle for such data than PARK AND CEMETERY, none that will set it up in better style. I would like to extend this invitation to the nurserymen and florists of the south and the Pacific coast. Those of the north, and the very select best of them too, already use and appreciate your journal as it deserves.

*James MacPherson.*

BOSTON, MASS., December 26, 1896.

*Editor Park and Cemetery.*

DEAR SIR:—In your issue of December, 1896, one of your correspondents would like to hear if anyone "has addressed himself to the harmonious composition of the trees and shrubs and herbs of a botanic garden with a view to embellishing the ground." If your correspondent will examine the plans and the grounds of Prospect Park, Brooklyn, N. Y.; the Arnold Arboretum, Boston, Mass.; the shrub collection at Highland Park, Rochester, N. Y.; the Botanic Gardens of South Park, Buffalo,

N. Y.; the plans of Cherokee Park, Louisville, Ky.; the Biltmore Arboretum at Biltmore, N. C., and the grounds of Smith College, Northampton, Mass., all of which were designed by the firm of which Mr. Frederick Law Olmsted is at the head, he will find that provisions have been made for collections of trees, shrubs, and in some cases herbs, arranged with their botanical relationship so far as this would not interfere with their value as an element of landscape. I know how thoroughly and carefully these matters were considered by Mr. Olmsted and other members of the firm, for it was my privilege while in their office to work out the details of all but the first two of these undertakings under their direction. Yours very truly,

*Warren H. Manning.*

A subscriber asks, "if a cemetery corporation has the power to tax private lots; by state laws cemeteries are exempt from taxation as far as I know."

[No. Taxing power is a function of government which can be delegated to, or exercised by, no private corporation. Whether a state will tax, or exempt from taxation, cemetery property, is a question of public policy which each state decides for itself. And in New York it has been held that if there is to be any taxation at all, an incorporated cemetery association should be assessed, and not the individual owners of lots therein. EDS.]

**A Few Thoughts.**

LYNN, MASS., JANUARY, 1897.

As I am sitting wrapped in thought on this beautiful winter day my mind wanders back to our convention at St. Louis. How could we have been better entertained? What more could have been done? I am sure no one expected so much. Brother Brazill is entitled to a vote of thanks, which he has already received; he has proved to be a man equal to any emergency. Long may he live to enjoy the position he now holds. President Creesy and myself had anticipated making one or two calls on our way home, but an unexpected telegram from home deprived me of that pleasure. My son was suffering from a severe illness, which looked against him when the telegram was sent, but I am happy to say he has nearly recovered his usual health.

The papers read by those other than superintendents was "A Happy Thought," and were very entertaining and instructive. It will be a pleasant feature at our next convention for every superintendent who cannot be present to write a letter to be read by the secretary. It will show that he still has an interest in the association. I hope this suggestion will be heeded, as it will add much to the interest of the occasion and keep us still near together.

We are now planning for our work in the spring, which will soon be here, when we shall find ourselves very busy. Our work will be all of the same nature. Many of us have improvements which we would like to make, but cannot for lack of funds; but there are many little improvements that can be made at small expense, which will be sure to be seen and appreciated by our lot owners. No standing still should be our watchword. Let us put our shoulders to the wheel and strive to do a little better this year than we did last.

Our new president, I am sure, will not lack for support from the members. Let us do all we can to help him, and as I am only five miles from him, I hold myself in readiness to render him any assistance and to accompany him to our next convention.

Merry Christmas has come and gone, and I would wish all who may read these lines a happy new year.

*William Stone.*

Superintendent Pine Grove Cemetery.



## Association of American Cemetery Superintendents.

G. W. CREESY, "Harmony Grove,"  
Salem, Mass., President.  
ARTHUR W. HOBERT, "Lakewood,"  
Minneapolis, Minn., Vice-President.  
F. EURICH, Woodlawn, Toledo, O.,  
Secretary and Treasurer.

## Publisher's Department.

Park Commissioners and Cemetery trustees are requested to send us copies of their reports.

Photographs and descriptive sketches of interesting features in parks and cemeteries are solicited from our readers.

### Back Numbers Wanted.

S. H. Curtis, vice-president and secretary Harlington Cemetery, Waverly, Ia., desires to obtain the following numbers of MODERN CEMETERY: Volume I, Nos. 1, 2, 3, 6, 10 and 11; volume II, Nos. 1, 2, 4, 5. A reasonable price will be paid for any of the above numbers, or would exchange with the following: Volume II, No. 10; volume III, No. 8; volume V, No. 5; volume VI, No. 4.

Mr. Frank H. Nutter, landscape gardener, Minneapolis, Minn., was recently engaged in replanting and rearranging certain portions of Harlington Cemetery, Waverly, and Fairview Cemetery, Waterloo, Ia., and Mr. S. H. Curtis, vice-president, writes us that the work was done to "more than my entire satisfaction." This is a gratifying recommendation of responsible services.

Mr. Andrew Ross, superintendent, Vergennes, Vt., is desirous of obtaining suggestions for a four column entrance to his cemetery. He is expecting to make such an addition to one of the entrances to the cemetery in the near future, and would appreciate any suggestive help that might be accorded him.

Oklahoma is progressing. The Oklahoma Agricultural, Horticultural and Irrigation Society held a three days' convention at Perry, O. T., on December 8, 9 and 10 last.

Mr. F. W. Higgins, Detroit, Mich., superintendent of Woodmere Cemetery, will read a paper before the meeting of the Michigan Marble and Granite Dealers' Association, which will be held at the Hotel Normandie, Detroit, January 26 and 27. The subject of the papers is: "Relations of Cemetery Superintendents to Granite Dealers."

A collection of excellent photographic views of Oak Grove Cemetery, Delaware, O., have been received from David Grinton, superintendent.

### RECEIVED.

Illustrated Descriptive Pamphlet of Tennessee Centennial and International Exposition. Opens May 1st, 1897, closes Oct. 31, 1897. Nashville, Tenn. Bureau of Promotion and Publicity, Nashville, Tenn.

Department of Parks, Paterson, N. J. Seventh Annual Report of the Board of Park Commissioners, 1896. Illustrated by half-tones.

City of Cambridge, Mass., Park Department, Annual Reports, 1896. Illustrated with photogravures.

Crown Hill Cemetery, Indianapolis, Ind. A memorial volume of over 200 pages, illustrated with numerous half tones, containing: Original Officers; List of Corporators; Introductory Article; Articles of Association, Rules and Regulations; List of Lot-Holders.

Views in Harleigh Cemetery, Camden, N. J., with compliments of George E. Rhedemeyer, superintendent. This handsomely illustrated souvenir comprises a number of half tone pictures of the prominent features, monumental and landscape, of Harleigh, bound in cloth. Copies may be had at 30 cents each from Mr. Rhedemeyer.

Photograph of "View in Prospect Cemetery," Vergennes, Vt. The photo shows a good class of granite memorials.

Botanical Society of America. Botanical Opportunity. Address of the retiring president, William Trelease, Sc. D., Director of the Missouri Botanical garden. Delivered before the Botanical Society of America at its second annual meeting, Buffalo, N. Y., August 21, 1896.

### THE LONDON BURIAL GROUNDS.

Notes on Their History from the Earliest Times to the Present Day. By Mrs. Basil Holmes. Illustrated. New York, McMillan & Co. Chicago, A. C. McClurg & Co. Price \$3.50.

An interesting volume is this work of Mrs. Holmes on "The London Burial Grounds." To read the introductory chapter, and note the difficulties encountered in gathering the information; hunting for evidences of a graveyard, which history records as existing, but which time has covered with a living population, leads one to ponder over the centuries through which the great city has continued to thrive, and on the various conditions through which its burial grounds have passed since history records its founding. Mrs. Holmes describes her difficulties,

and in the ensuing chapters records the facts she has gathered. The following list of chapter heads gives a good idea of the scope of the work: British and Roman Burying Places; The Graveyards of Priories and Convents; The Cathedral, the Abbey, the Temple and the Tower; The City Churchyard; London Churchyards Outside the City; Pest Fields and Plague Pits; The Dissenters' Burial Grounds; Burial Places of Foreigners in London; Hospital, Almshouse and Workhouse Grounds; Private and Promiscuous Cemeteries; The Closing of Burial Grounds and Vaults; Graveyards as Public Gardens; The Cemeteries Still in Use; A Forecast of the Future. An appendix containing lists of burial grounds in existence, and those which have disappeared, with other information, completes the work.

One can picture to a certain extent what these old-style churchyards and burial grounds are and have been, but there is a gruesome fascination in reading of the slow development which has attended the burial ground, together with the different conditions which have governed the examples possessed by old London. Compared with our modern cemetery these old graveyards are strange anomalies. Even with the more modern cemeteries of London the authoress finds grave cause for criticism. She places herself on record on the subject of waste both in the line of memorials and modern funerals. There is much of historical interest in this book, as well as a fund of suggestive material, which adapted to practical ends would tend to progressive work.

### The Spider Tree of Africa.

Travelers who visited or passed the Cape Negro country of Africa often heard from the natives of a plant that was part spider, and that, growing, threw its legs about in continual struggles to escape. It was the good fortune of Dr. Welwitsch to discover the origin of the legend. Strolling along through a wind-swept tableland country, he came upon a plant that rested low upon the ground, but had two enormous leaves that blew and twisted about in the wind like serpents—in fact, it looked, as the natives had said, like a gigantic spider. Its stem was four feet across and but a foot high. It had but two leaves in reality that were six or eight feet long and split up by the wind so that they resembled ribbons. This is probably the most extraordinary tree known. It grows for nearly, if not quite, a century, but never upward beyond about a foot, simply expanding until it reaches the diameter given, looking in its adult state like a singular stool on the plain from ten to eighteen feet in circumference.

When the wind came rushing in from the sea, lifting the curious ribbon-like leaves and tossing them about, it almost seemed to the discoverer that the strange plant had suddenly become imbued with life and was struggling to escape. When a description and picture of the plant were sent to England, it was, like many other discoveries, discredited, but soon the plant itself was received, and now Welwitschia minabilis is well known to botanists.



# PARK AND CEMETERY.

FORMERLY THE MODERN CEMETERY.

A Monthly Journal Devoted to Parks and Cemeteries

R. J. HAIGHT, Publisher,

384 Dearborn Street, CHICAGO.

Subscription \$1.00 a Year in Advance. Foreign Subscription \$1.50

VOL. VI. CHICAGO, FEBRUARY, 1897. No. 12.

## CONTENTS.

EDITORIAL.....	415
*CHATTANOOGA—CHICKAMAUGA NATIONAL MILITARY PARK.....	416
*HYBRID WICHURIANA ROSES.....	419
NOTES FROM THE DOG-EARED BOOK OF A TRAVELER AND OBSERVER.....	420
*CHAPEL, CONSERVATORY, ETC., ROSE HILL CEMETERY, CHICAGO.....	422
*GARDEN PLANTS—THEIR GEOGRAPHY XV.....	424
NOTES.....	425
*THE BLATZ MAUSOLEUM, MILWAUKEE, WIS.....	426
*THE EVERGREEN MAGNOLIA.—NELUMBIVM ALBUM, GRANDIFLORUM.....	427
PARK NOTES.....	429
CEMETERY NOTES.....	430
CORRESPONDENCE.—REFORMS IN FUNERALS.....	431
PUBLISHERS DEPARTMENT.....	432

\*Illustrated.

AN increasing love for botany, at least so far, as more interest is being taken in flowers, trees and plants, is evidenced in many directions and is a cause for gratification. The most favorable evidence, in that it bespeaks permanent results, is the work done in the public schools. At present this is not so marked in respect to regular work, as in the increasing efforts of teachers to interest their pupils in botanical subjects, and all over the country it may safely be said that the children of this generation are far ahead of their ancestors in a knowledge of the flora of the locality. Considering the excellent discipline that may be imparted to the youthful mind by even elementary object lessons in botany, to say nothing of the refining influence that a love of flowers and plants inculcates, it would appear beneficial to encourage the young as far as practicable in so healthful a field. Nothing will aid so rapidly in beautifying the homes of the American people as cultivating this love of nature in the young, and nothing will yield more bountifully in refining the coming generation. There is scarcely any part of the country that will not afford ample material for generous study, and principals and teachers who are in harmony with this growing idea should be encouraged to persevere in the good work.

ECONOMY in cemetery finances may, as in other business affairs, be carried too far, a fact which occurs to us upon realizing the efforts made by many of the financial officials to present a good annual report. Especially is this noticeable in the amounts expended for improving the grounds under the superintendent's direction. When large balances accrue, to be carried forward from year to year, or invested as the case may be, while so much remains to be done to bring the cemetery up to the standard of modern ideas, it is a matter worthy of deep consideration whether such is the true economy. Rather it may be expected, that the greater perfection the grounds may be made to assume from a landscape standpoint, the more attractive and valuable they may become, assuring a stronger demand for lots at, if advisable, advanced prices. This would be a positive outlay, but wiser than a negative economy to provide a good balance sheet.

THE unauthorized photographing and sketching of monuments in cemeteries is a serious question, as well as one very difficult to regulate. It is a simple matter to frame rules prohibiting this or that particular feature of the case; it is a complex one to enforce them. Stringent rules have been enacted looking to the absolute prohibition of copying, photographing or sketching monuments in cemeteries without express permission from qualified authority, but the variety of mechanical means to evade such strictures practically nullifies them. All that appears then to remain to the cemetery officials is to rigidly enforce their rules, so long as they do not work a meaningless and arbitrary restriction where no possible harm can come, and exercise their authority among their lot-owners to prevent duplication and the unscrupulous adoption of such original features of design as may already grace other memorials on their grounds. In Pere La Chaise, Paris, the Campo Santo, Genoa, and many other European cemeteries, the rules against photographing or sketching are entirely prohibitory and are rigidly enforced. In some cases the consent both of the owner of the memorial, the sculptor and the cemetery officials, must be obtained. Until such rules are enforced, reproductions, oft times inferior may be expected. The cemetery lot owner who desires to promote art in memorials deserves every protection.



## Chattanooga-Chickamauga National Military Park.



MONUMENT TO BRIG. GENERAL  
JAMES DESHLER, C. S. A.

enthusiasm, and the little bustling "Mountain City," lying in the Moccasin Bend of the Tennessee river and under the shadow of majestic old Lookout, was endued with a new importance. She was to be hostess at an event in American history, and a consciousness of the honor and responsibility of her position caused her to put forth her best energies in every direction, and the record shows a complete success.

This event was the formal dedication of the battlefield of Chickamauga as a national military park. What a time it was! "Yanks and Johnnies" met and clasped hands by the banks of the famous "Bloody Pond," and in the many magnificent orations delivered during the dedicatory ceremonies each tried to outdo the other in generous, noble, patriotic and laudatory expressions. Perhaps the most notable addresses delivered were those of Maj. McKinley, president elect, representing the one side, and the South's matchless orator and gallant soldier, Gen. John B. Gordon. Each of these men received an ovation.

Ohio was largely represented at the dedication, and Editor MacGowan, of the *Chattanooga Times*, commenting on the fact, said: "When you can find nobody else, you can find an Ohio man. He is made conspicuous by his presence in great numbers. Well, he ought to be. There was much of him here thirty years ago. Ohio is never behind on any occasion, be it a fight, a foot race or a race for a good, fat office!" He doubtless little thought when he penned those words that in one year, or a little more, the Ohioan who formally received the monuments of his state and in such graceful words tendered the Commission thanks, in the name of that state, for the able and highly satisfactory work done, would be the victor in the race for the biggest, fattest office our country affords.

So much has been written and said of Chicka-

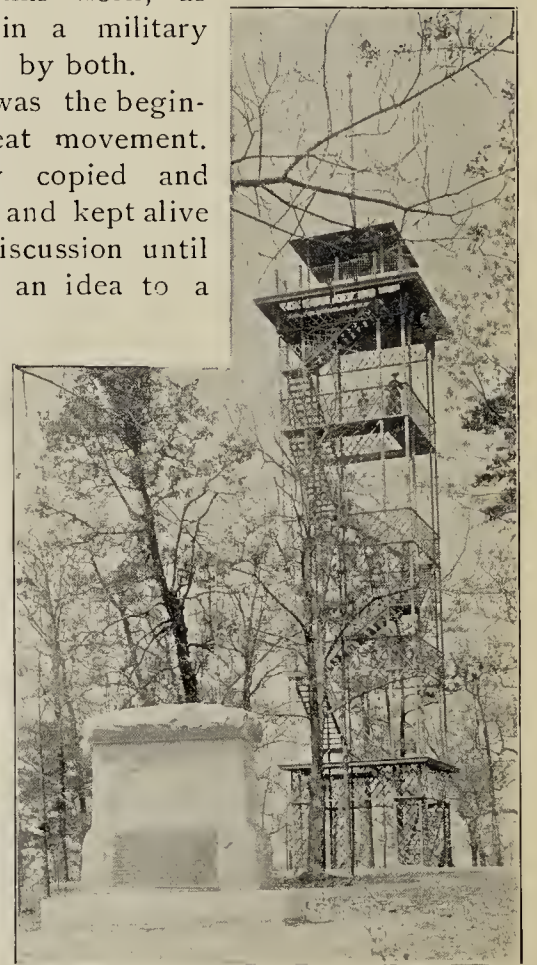
mauga from a historical standpoint that I will not attempt even to touch upon that phase of the subject in my brief sketch. It is the park with which I have to deal, and that in itself is a most pregnant subject.

One Sunday morning in June 1888, Gen. H. V. Boynton and Gen. Ferd. Van Derveer, who happened to be together in Chattanooga, started out for a buggy ride. Both of these gentlemen had been engaged in the battle of Chickamauga, so they made it the object of their drive to visit and study the old battlefield. The trip proved to be so interesting to these two veterans that then and there the plan of converting the famous battlefield into a national military park was conceived.

To think was to act in this instance.

Gen. Boynton was at the time Washington's correspondent for the *Cincinnati Commercial Gazette*, and, upon his return to Washington, he wrote a very enthusiastic letter to that paper, setting forth in detail his idea with reference to Chickamauga, and urging the importance of preserving this battlefield, and marking by tablets and monuments, the positions of the troops, places where prominent officers fell, and other details essential to an accurate perpetuation of a historic place. It was, further, his idea for the veterans of both armies to unite in this work, as here renown, in a military sense, was won by both.

This letter was the beginning of the great movement. It was widely copied and commented on, and kept alive by continual discussion until it passed from an idea to a probability and then to a certainty. Interest was never allowed to lag for one moment and no time was lost in organizing and setting a competent committee to work. It is impossible, at this time, to follow up and report steps taken from time to time to advance the cause;



TOWER ON SNODGRASS HILL AND MONUMENT TO 35TH. OHIO INFANTRY.



suffice it to say, they were well taken.

During the winter of 1889-90, Congressman Charles H. Grosvenor, of Ohio, introduced a bill, framed by Gen. Boynton, asking for an appropriation of \$250,000 to buy 7,600 acres of land desired for the park, and for the contemplated improvements. The plan now was to include portions of Lookout Mountain, the battlefield of Missionary Ridge, and smaller plots about Chattanooga. The whole was to be called the Chickamauga-Chattanooga National Military Park, and to be under control of the secretary of war. Gen. Grosvenor introduced the bill in the House of Representatives, and it was cordially supported, being disposed of in twenty-three minutes when the time came to vote upon it, and not receiving a single adverse word or vote. It passed the senate in twenty minutes.

The whole scheme from the beginning, was characterized by promptness of action. No time was lost, no useless volubility expended.

The park is not and never will be a model of the art of landscape gardening. There are no conventional beds of foliage plants, carefully and methodically clipped; no crosses, mottoes or emblems made of flowers; no shrubbery trimmed to an exact height; no velvet turf to be rolled and mown. Such was not the design of its projectors, yet it has a beauty and picturesqueness all its own by nature that does not in any way conflict with one's idea of a military park. It is far from being a sombre or gruesome place, and the sun shines just as brightly upon it as upon the most ornate and artificially beautiful city park. Birds sing in the branches of



A GLIMPSE OF THE PARK.



PART OF THE CREST ROAD,  
MISSIONARY RIDGE.

the fine old native trees, although bullets and balls are buried in their trunks. Wild flowers spring in abundance from soil that has been drenched with the blood of brothers in conflict.

When the bill was finally passed, it called for fifteen square miles of land, including most of the Chickamauga field, with an appropriation of \$125,000. The secretary of war immediately appointed four commissioners, all of whom had served in the engagements about Chattanooga. They were Gen. Joseph S. Fullerton, chairman; Gen. A. P. Stewart, Capt. S. C. Kellogg, and Gen. H. V. Boynton, historian.

The entire appropriation had been increased to over \$1,160,000 up to the date of the dedication, this sum including the state funds as well as those set apart by the government.

At the time of the dedication there were 125 monuments and 500 tablets and markers on the field, also about 200 cannon of the same kinds used by the Union and Confederate batteries during the battle. Three hundred more will be mounted.

There are nine monuments to regular organizations, also eight pyramidal shell monuments, 10 feet high and made of eight inch shells, four of which are erected on spots where Union general officers were killed or mortally wounded, and four mark the spots where Confederate general officers fell. The one shown in our illustration perpetuates the memory of Brig. Gen. James Deshler, C. S. A., killed about noon on Sept. 20, 1863, at that spot.



The work has been carried on as impartially as possible, the commission making use of such collected facts from both sides as came into their hands.

Besides the monuments, there are five steel observation towers, 70 ft. high and 20 ft. square, three of which are on the battle field and two on the crest of Missionary Ridge. All are erected on historic spots, and from the top of each a magnificent view may be obtained.

In the park proper, the government had spent over \$750,000 and the different states about \$400,000 up to September 1895.

An enormous amount of work has been done in the park since its establishment. About 3,300 acres of land were cleared of underbrush and also of as much timber as was necessary to establish correctly the lines of battle, positions of batteries, and points where officers fell. New roads were closed and old ones re-opened, and the land restored as nearly as possible to aspect of the time.

Nearly fifty miles of first-class macadamized roads have been built, twenty-five of which run through the park in every direction for the convenience of the visitor. The axis upon which the two days' engagement turned was the La Fayette road. The Confederates were trying to take it in order to reach Chattanooga, and the Unionists were trying to hold it, and thus prevent the former from entering the city. This is the road that is called the Crest road, after leaving the boundary of the park, taking its name from the fact that it runs for about eight miles along the crest of Missionary Ridge.

A year ago, one of the Chattanooga florists was appointed by the government to root some honeysuckle vines to be planted on the banks overhanging this road, in order to add a rustic appearance to an already picturesque and beautiful driveway. The plants were obtained in wagon loads from the old Citizen's Cemetery in Chattanooga, which is simply over-run with these vines. The florist cut them in pieces and rooted them, being paid five dollars per thousand for them. They were planted out and are doing well, and this spring the park engineer will train them carefully. In addition to doing their duty as beautifiers of the landscape, they will serve the useful purpose of preventing the banks from washing.

A new appropriation of \$125,000 has recently been made in order to take in Hooker's "Battle above the Clouds," which no Confederate acknowledges to have been fought, and even Gen. Grant calls a myth. Lookout Mountain was abandoned by the Confederates, and that mythological battle has been fought in some vivid imaginations since the surrender.

A monument to the 19th Illinois Infantry has

been erected on the Crest road, Missionary Ridge, where that regiment stood during the famous charge.

Rights of way for the extension of the government boulevard to Ringgold, Ga., have been secured, and the work is now in progress.

Those having the matter in charge hope to have the proposed electric railway from Chattanooga to the park in operation by spring, which will be a great convenience to visitors.

On Monday, Nov. 23, 1896, the New Jersey park commissioners, with a distinguished party, visited Chattanooga, for the purpose of dedicating a very beautiful monument erected on Orchard Knob. New Jersey had two regiments on this battlefield, and has erected handsome monuments to each. This last one cost \$14,000.

Hon. J. P. Smartt, of Chattanooga, has taken a great interest in the park and has rendered some valuable services, as assistant to the park commission, in locating the lines of the Confederates and determining the details of their movements.

Governor Daniel H. Hastings and a party of prominent Pennsylvanians also visited Chattanooga in November for the purpose of inspecting the monuments to Pennsylvania troops at Chickamauga, and to make the preliminary arrangements for the formal dedication of them, which will probably occur some time next May.

Gen. J. S. Fullerton, president of the Chickamauga-Chattanooga National Park commission, with the other members of the commission, was in Chattanooga in November. In an interview with one of the daily papers, published November 23rd, he said that he would be there for some time and expected to push things right along, that they proposed to go right on with the work of establishing the lines of battle at the park, and that the work of clearing away underbrush and shrubbery is going on all the time. Some new roads will probably be opened up at once in different portions of the park.

The New Georgian monument, which is said to be the finest in the whole park will cost in the neighborhood of \$25,000. It will be a granite shaft, sixty feet in height, surmounted by figures in bronze.

Truly, times change and we change with them. The first visit that the writer, who is the daughter of a Rebel colonel, ever paid to Chickamauga Park was with a gay party of picnickers in the summer of 1891. My especial escort on that occasion was a young man whose father wore the blue. It was a beautiful midsummer day and the place was looking its best. At noon, we sat under some trees on the crest of Snodgrass Hill and ate our lunch with much relish. The son of the Yankee polished a chicken



bone, while the daughter of the Rebel demolished a ham sandwich and a hard boiled egg, both talking the while, with no trace of bitterness, of the scenes enacted there in the sixties.

We found several bullets near the spot, also an ornament from the cap of a Federal bugler. These, with some wild flowers, and the memory of a very bright, pleasant day, we carried home with us.

Louisville, Ky. *Elizabeth Fry.*

**Hybrid Wichuriana Roses.**

*Rosa Wichuriana* promises to yield a group of garden hybrids of especial use in cemeteries. The original species introduced to this country in 1891. It



1. *Wichuriana*.      2. *Favorite*.  
3. *Manda's Triumph*.      4. *South Orange Perfection*.

has single white flowers in clusters and is of a very neat but vigorous trailing habit peculiarly well adapted for covering mounds. It will be all the better of course for a barrowfull of good soil to plant in, but its long shoots may be trained over rocks if necessary. It is hardy as a rose can be, but this habit of creeping over the ground will naturally adapt it to the north-west and other sections of the country where the snow lies in winter, affording its full protection. Where it will live without the covering of snow, (as it does in all places yet heard from) the shoots grow on established plants 8, 10, or even 15 feet in a season, and these long shoots may of course be trained upon railings or other supports if preferred. The group of four hybrids surrounding the photograph were raised and selected by Mr. W. A. Manda of South Orange, N.

J., (formerly of Short Hills.) They partake of the excellent characteristics of the parent with the added charm of doubleness, fragrance, and variety of color. No 1 is called the "Pink roamer" by the raiser, and is a very luxuriant grower. (2) is called the "Universal favorite," (3) is "Manda triumph," and (4) the "South Orange perfection." These roses will no doubt become very useful and popular for memorial purposes, and are worthy of extensive trial.

Another notable rose of late years is a hybrid *R. multiflora* raised by a gentleman in Lincolnshire, England, a county with a very New England kind of climate, which yielded also to this continent the original *Mayflower Pilgrims*. It was first exhibited in this country at the International Exhibition of Chicago, under the raisers name—"The Engineer."

It was purchased and disseminated by Chas. Turner's Sons of the Royal Nurseries, Slough, near Windsor, and was made the object of a special visit by Her Majesty the Queen. Turners thought it expedient to rechristen it "Crimson Rambler," but I am often doubtful if any money purchase warrants these proceedings except in the case of atrociously bad names.

Still another hybrid of *Rosa multiflora* (syn. *polyantha*) has yellow flowers, and is of German origin. I suppose the original name to be "aglaia," but it also has been called a rambler. It is claimed to have been fertilized by pollen of the buff yellow "Reve d' Or" of Ducher, a Noisette rose. These Noisette roses are themselves of American origin, having been raised by a French gardener whose name they perpetuate. I am not aware if any authoritative figure of the original is in existence, but the rose was sent to France in 1814. Probably the

Kew people have something which they regard as the typical Noisette, and they quote it as a hybrid between *R. Indica*, and *R. moschata*, itself an Indian rose, but widely diffused westwards to the Mediterranean countries.

There seems a very strong probability however that Noisette worked with the "Prairie rose," *R.*



AGLAIA. (Yellow Rambler.)



setigera, and that it contributed pollen for his variety. The habit of many of them, very strongly points to the assumption. If this be so, it is not surprising to find their progeny developing traits of considerable hardihood, for the prairie rose ranges from Ontario to Florida, and west to Nebraska.

Aglaia or yellow Rambler is being disseminated by Jackson & Perkins, and may be supplied by any of the firms advertising in our columns.

*J. M. P.*

---

**Notes from the Dog-Eared Book of a Traveler  
and Observer.**

In the south of Wales, in the eighteenth century, white marble stones for graveyards were a rarity, though the custom of making both the head and the foot of a grave was in vogue. It was the invariable custom of the people to whitewash these grave stones for the three great religious festivals of the year, Christmas, Easter and Whitesuntide.

\* \* \*

In the burial ground of the Abbey at Dunblane, Scotland, fully one-fourth of the tombstones erected between one and two centuries ago, are marked in low relief, with the symbols of trade of the respective occupants of the graves. Thus a sugar cane indicates the burial place of a grocer, an ax, saw, hammer and nails indicate the grave of a carpenter, an awl and a hammer that of a shoemaker. Such representations are likewise found in other parts of Scotland upon tombs of like antiquity.

\* \* \*

The custom of making places of sepulture with stone inscribed with epitaphs is so ancient as to have been mentioned by Cicero. Probably the earliest form, after the resort to earth burial was a simple slab laid upon the grave. And this form has been preserved among the Moravians of Bethlehem, Pennsylvania. In the "God's Acre" connected with their church the graves are in straight lines and each marked by a white slab about eighteen inches square, bearing a simple inscription of name, date and age, laid flat upon the mound. The yard is kept in perfect order and the effect is one of repose, though looking down from the belfry of the old church, the white squares are very suggestive of laundered napkins bleaching upon a lawn. Some years ago a new cemetery was opened for the Bethlehemites, upon a picturesque bluff overlooking the Lehigh river. There, startling innovations upon the old Moravian customs were introduced in the form of pretentious monuments for families or for individuals.

\* \* \*

The Shakers use an upright slab at the head of

each grave with the simple initials and a date. And their cemeteries are laid out with the same perfection of regularity that characterizes anything that belongs to them, though there are no paths nor is there the slightest effort made to beautify the place. The Harmonites of Harmony, Ohio, who are religious economists, (or economic religionists) maintain the custom of leveling, turving and rolling the grave of the dead, immediately after interment, to express their idea of death as the great leveller. They sink the identity of their dead in the great mass of those who have departed out of this world. Their cemetery is an apple and pear orchard. Thrifty people are the Harmonites! So indeed are all who resort to the community mode of life.

\* \* \*

Epitaphs, whatever other purpose they may have served since they first began to embellish the tombs of the dead, have certainly "given variety to our thoughts in passing. And there are few note books which have been carried far and industriously used, that do not contain epitaphs galore. Most of them note the "prævit"—he is gone before,—on a stone in the ante-chapel of St. John's College, Oxford, over the body of a fellow of that college, as the most concise epitaph yet discovered. Most of the many contained in the note book here excerpted, have a ludicrous effect, almost always the result of their naivete. Here is an instance which has not been made public before probably. It is on the tomb of a highly respected squire in Warwickshire, who was, as set forth in the inscription which precedes, "Accidentally shot by his gamekeeper." The epitaph "Well done, thou good and faithful servant," seems rather ambiguous in such close connection, although in strictly scriptural language.

\* \* \*

Nowhere in the world is to be seen anything like the Cypress cemeteries almost surrounding the city of Constantinople. The cypresses have attained to enormous proportions, and the dark, almost black, glossy foliage, is so dense that the sunlight penetrates only in slender beams. The trunks appear like innumerable columns supporting this dark ceiling. Crowded together between these columns are the gravestones; huge, grotesque representations of the human form crowded with fez or turban, painted red or gilded, according to the age of the grave. For these stones are intended to represent the occupants of the graves as they appeared in the flesh, each in his characteristic dress. And fashions of head dress have changed even among the conservative orientals; and there is considerable difference between the huge turban of the time of Mahmud



II, and the modern fez. How close to each other these gravestones stand! So close that it would be impossible to thread one's way through them; and where they are neglected and have toppled over, they lie like fallen timber one over another. So the dead of different periods must have been buried in the same spot, or wedged in wherever soil could be found to cover them up. And this accounts for the fact so readily noticeable, that while the cypresses will scarcely survive if planted upon any of the hills or in any of the vacant places about Constantinople, they come to giant growths in the soil enriched by the innumerable dead of an oriental city.

\* \* \*

The Italian cemeteries give us a very poetic and very attractive image of eternal rest. The dead are not represented as inanimate beings completely insensible to external things. They sleep; and they are protected in their sleep, with all love and care. Hence mausoleums and marble couches are made for them to enjoy upon awakening. And they might be expected, from the objects that surround them, to arise with a smile of gratitude for all the tender care that has been apparently bestowed upon them during their temporary effacement. This is the undoubted motif prevalent with the Italian designers of mortuary architecture. Indubitably this idea of death is derived from the pagan ancestors of the modern Italians; for it seems to be analogous to that of the Etruscans, who enclosed in their tombs the characteristic belongings of their dead; his arms if he were a soldier; the brush or chisel, if he were an artist, the implements of his trade if he were an artisan. They also added lamps of exquisite design, and fruits and wine, in order that he might satisfy his wants, if he should awake. The French have something of the same materialistic idea of death, but they do not express it so pleasingly in their mortuary architecture. They are more intensely dramatic and in their dramatic scenes they are more realistic. The effects they produce are often shocking to the public sense. An instance where the French realism reaches its utmost height (or depth) is seen in the churchyard of Colmar. The citizens of Colmar erected a monument to the memory of two Frenchmen shot by the Germans when the latter entered the town in the Franco-Prussian War. Nothing unusual is apparent about the monument until the observer stands close to it. Then it is observed that one side of the horizontal slab is slightly raised, and from the grave beneath, a life-size hand of bronze protrudes and grasps the edge of the stone, while elsewhere a whole arm is stretched out in an endeavor to grasp a real French bayonet

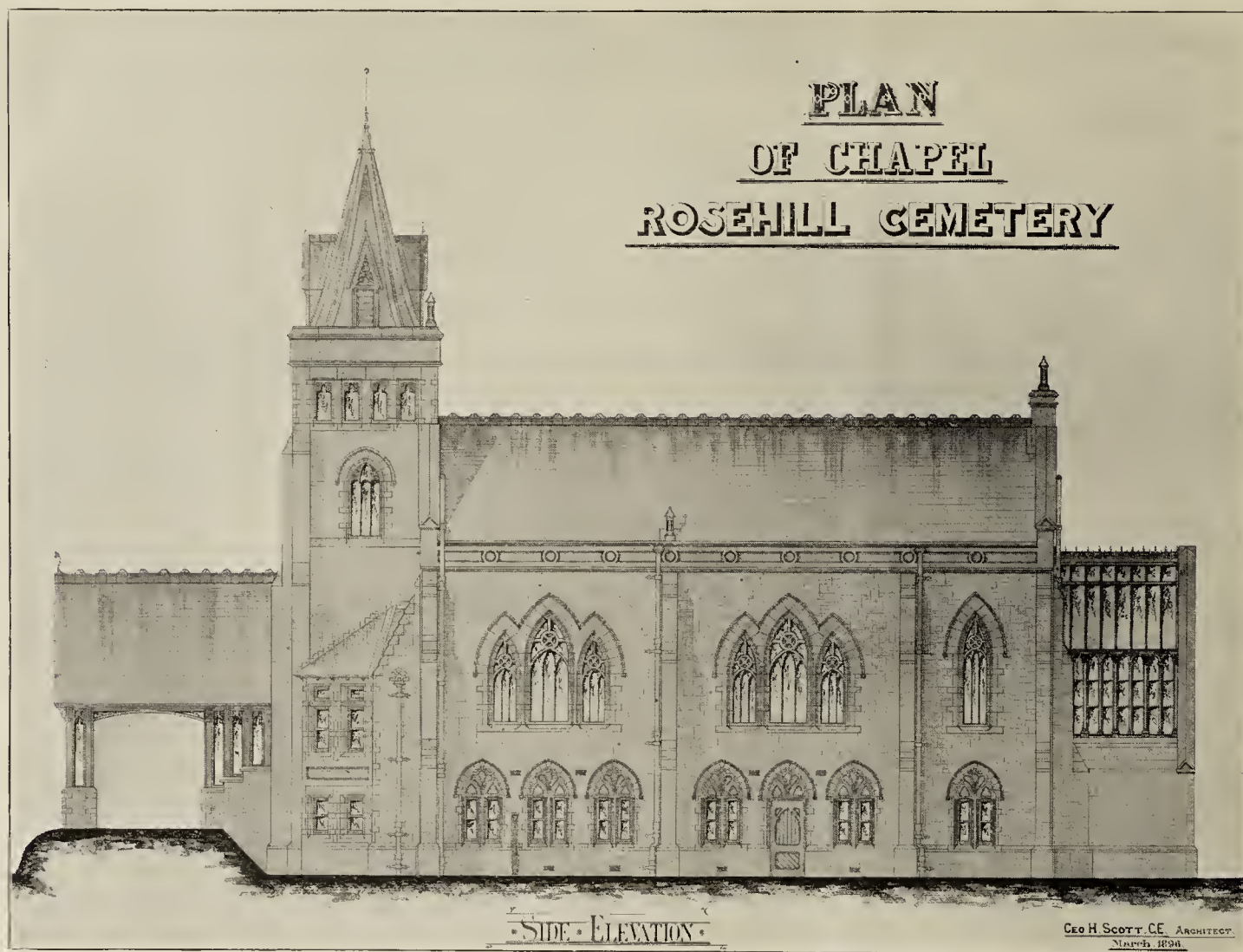
lying near. The whole has the appearance of a person buried alive trying to escape from the tomb. It is startlingly realistic, and it is no wonder that ladies who have come suddenly and unprepared by in view of this tomb have been known to faint from terror.

\* \* \*

In some parts of China a bamboo grove is converted into a cemetery under conditions far from agreeable to contemplate. The dead are swathed in matting and lashed in an upright position to the stems of the bamboo. The birds, insects and the elements reduce them in a short time to skeletons. The bones are then washed in hot water and classified for final burial; that is the male bones are separated from the female, for burial in a separate grave. But in the greater part of that vast country, more reverent attention is given to sepulture, and the cemeteries are very much in evidence. The Chinese are, however, an agricultural people and are economical of arable land. So that in the alluvial rice lands for example, so little land can be spared for the dead that the cemeteries are very small for the number of graves that have to be accommodated. To account for the possibility of getting so many graves in such a small area, it is necessary to adopt the hypothesis that the bodies are buried in an upright position or one on top of another. The tapering mounds, sugar loaf shaped, in such cemeteries are very close together and present an appearance similar to that of a village of African white ants. In some districts a cemetery consists of a number of large earthen jars, each of which contains a dead body in a sitting posture, and is set in a niche in the rocky cliffs of the mountains. But by far the greater part of China seems to be divided between the living and the dead upon the following terms:—the living build walled cities in, or otherwise occupy the level ground; the dead are buried on the hills. There are no fences or other limitations to these hill cemeteries. No corpse is allowed to be buried within the walls of a Chinese city. The modes of sepulture varies from the "horse-shoe grave," or vault built into the hillside with the outer end formed like a horse-shoe, down to the shallow graves into which the poor put their dead; marked by a small tablet of wood or stone. The Chinese graveyard is not generally so disreputable as those of Persia or Turkey, and the Chinaman as a rule pays great respect to the dead. Yet the cemeteries are often out of repair and even the horse-shoe graves are sometimes so dilapidated as to expose to the passers by the crumbling coffin and skeleton within.

*L. Viajero.*





**Chapel, Conservatory and Receiving Vault, Rose Hill Cemetery, Chicago.**

The accompany illustrations of the new Chapel, Conservatory and Receiving Vault combined, in course of erection, Rose Hill Cemetery, Chicago, represents the most recent practice in such structures. The building and its details are from the design of Mr. Geo. H. Scott, C. E., superintendent of the cemetery.

The building has two floors, the ground floor and the chapel floor. The ground floor which is 6 inches above the level of the ground consists of receiving room, boiler house, box, storage, toilet rooms, store rooms, coal house and crypts. The latter measures 30 feet by 15 feet and contains 28 crypts. The crypts are built in white-glazed brick-work 4 inches thick, the floors being slate. They are supplied with fresh air by means of horizontal iron air pipes  $1\frac{1}{2}$  inches in diameter, which are connected to the outside by an open iron grating sufficiently high to cover the whole of the ends of inlet pipes. The pipes are perforated within each crypt. The ventilation is by means of similar perforated pipes which are connected to two 12 ft. by 9 ft., ventilating shafts built in the brickwork of the tower, each shaft being fitted with a powerful air-extractor. The air

supply pipes are fixed at the lower front of crypts and the ventilating pipes at upper rear of same. By this means a continual current of air is passing through each crypt. The floors are slightly sloped, and an arrangement of water pipes is provided for the purpose of being able to have a run of water through each crypt, the water being carried along the backs of the crypts into the sewer. The divisions between crypts are of white glazed brick work, the doors being slate, fitted with heavy brass handles and are arranged on the "drop in" principle.

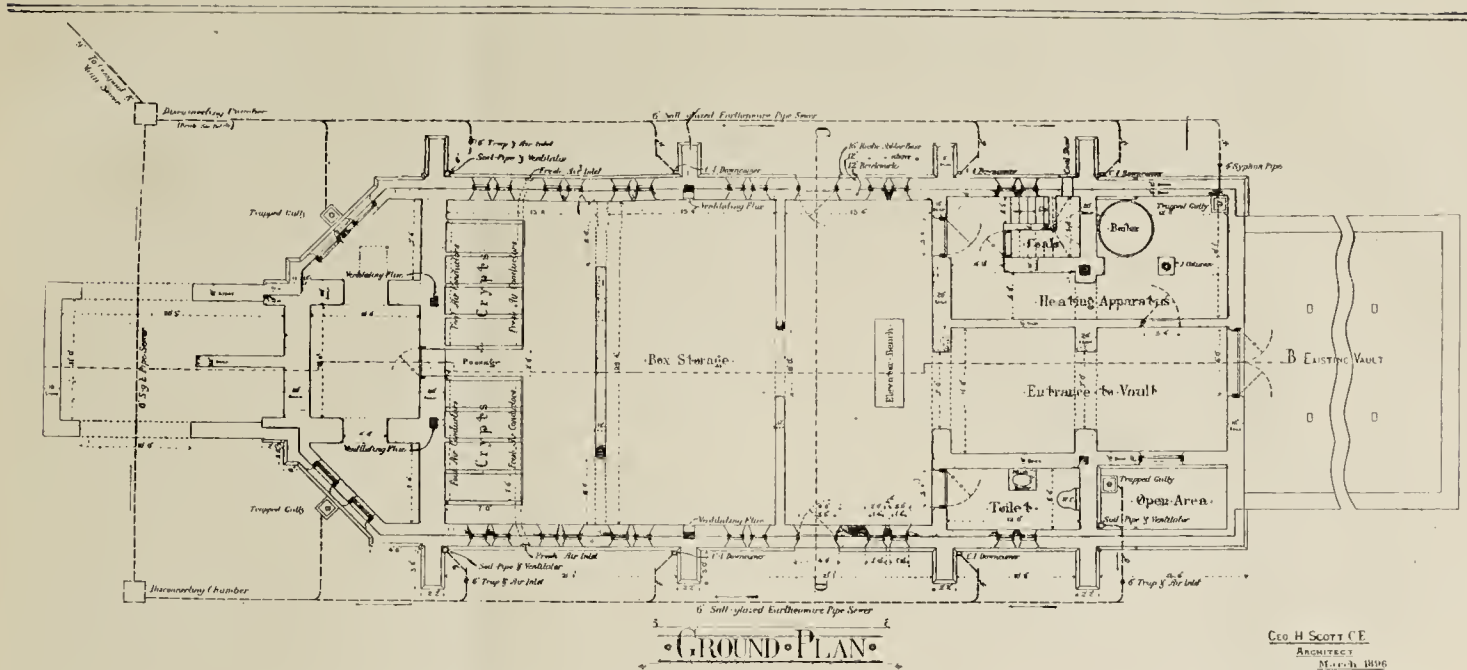
The receiving room is built in white glazed brick work and measures 30 ft. by 15 ft.; in the centre is a receiving bench with slate top, immediately under the hydraulic lowering apparatus and elevator, which is used for lowering the caskets from the chapel floor above.

The boiler house is 25 ft. by 12 ft., and contains the heating apparatus, coal-house, etc.

The height of this floor is 9 feet, with walls 2 feet thick the full height, the inner 12 inches is brick work, the out portion is 12 inches rusticated granite.

The chapel floor contains vestibule, chapel, chancel, conservatory, robing room, two toilet





rooms, etc. It is approached in front from a porch 15 ft. by 14 ft., through which carriages may drive.

The chapel is 50 ft. by 30 ft., with a height of 22 feet to the underside of the tie-beams and 34 feet to ridge plate. The walls are 20 inches thick. Opposite the chancel is the hydraulic apparatus and elevator upon which the caskets are placed during the time service is being held, after which they are lowered into the receiving room below. The conservatory, 18 ft. by 15 ft., is provided with stepped benches all round to a height of 10 feet; it is built of iron and glass. The height of the chancel is 20 feet, and the ceiling is heavily moulded in oak panels.

The chapel is supplied with fresh air by means of 8 hit-and-miss iron inlets. The ventilation is by means of two moulded brick bulls-eye ventilator openings in which are inserted iron gratings, 25 feet above the floor, one at each end of chapel. These are connected to 12 in. by 9 in. air shafts in the brick work.

The tower is 55 feet in height to the top of walls, 75 feet high to bottom of iron finial, which

is 7 feet in height. The tower is lighted by windows, three on first floor, and 16 smaller ones on top floor or belfry. The roof has four ornamental gothic louvre windows, one on each side.

The roof of chapel is heavily moulded oak, the principals being alternately covered down the wall from tie beams and stopped on stone moulded and projecting base stones. The roof is open and queen post type, the under side of spans being panelled and moulded the whole area of roof. Its seating capacity is 150. The style of architecture is Gothic.

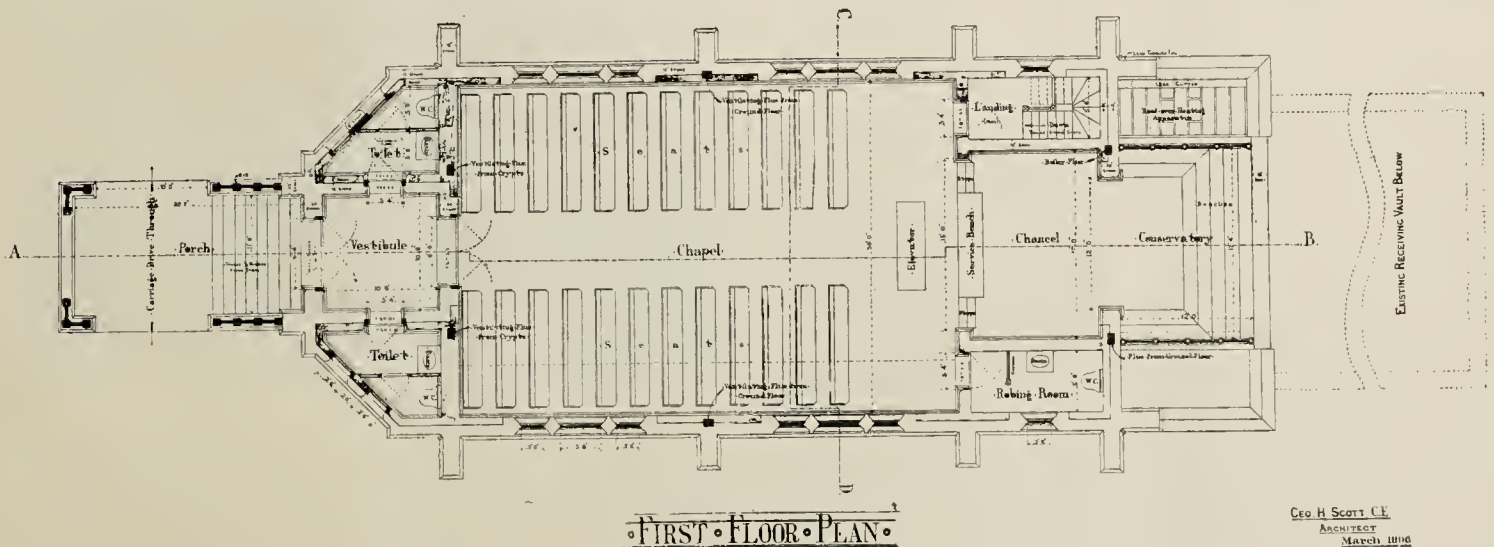
The roof will be covered with square tiles finished with ornamental tile ridging.

All sewers are properly trapped and ventilated by pipes carried up tower.

The foundations of all the walls throughout the structure are laid on a bed of Portland cement concrete 3 feet thick.

The granite material, purchased and delivered in the "rough," is worked at the site to full-sized detail drawings, as the building proceeds.

The cost for the whole of the works is estimated at \$50,000.





## Garden Plants, Their Geography, XV.

ROSALES (A.)

THE GENISTA, ROSA AND DROSERA ALLIANCE.

(Continued.)

*Dorycnium* is in six species from Mediterranean regions. They are tender evergreen sub-shrubby



Seed Section Magnified.

Flower Magnified.

INDIGOFERA TINCTORIA, THE INDIGO PLANT.

perennials in Britain, with red, white or red and white flowers. *D. suffruticosum* is perhaps as hardy as any of the evergreens. The herbaceous ones stand more cold.

*Lotus* has from 50 to 100 described species (?) from Europe, Asia, Africa, America and Australia. They are mostly from the warmer regions, but several pass northwards, *L. corniculatus* and its varieties being well known. *L. Porto-sanctanus* is said to be a small evergreen shrub; I don't know it, but *L. peliorhynchus*, with scarlet flowers, has recently been advertised and not very long ago introduced from Teneriffe. *L. Jacobæus* comes as near to a black flower (sometimes) as anything known, and there are other small, tender evergreens perhaps useful as bedders.

*Amorpha* has eight species of shrubby or sub-shrubby plants, all from North America and with pretty purple or blueish flowers.

*Indigofera* is a large genus of 270 species, dif-fused over all the warm regions of the world. They are annual or perennial herbs or evergreen shrubs,

often quite handsome. Among the latter *I. decora* and vars. is from China and Japan and *I. Gerardiana* (Dosua) from the Himalayas. These are hardy enough to live as herbaceous plants northwards. It is likely that such as *pulchella*, *atro-purpurea*, *spinosa*, etc., might also prove useful southwards. The four native species are from the Gulf states and are hairy herbs or sub-shrubs with loose panicles of pink or purple flowers. The indigo plant has natu-ralized south also, and was once largely cultivated there.

*Galega* has but three species. They are tall herbs from Central Europe and Western Asia, with purple, blue, and white flowers.

*Wistaria* is in two or three species and a num-ber of varieties, some of them double flowered. They are natives of Eastern Asia and the Southern United States. Both the Asiatic and native spe-cies have white forms, and all are well-known, hand-some climbers.

*Fordia* in close affinity is a monotypic genus from China.

*Robinia*, "Locusts," have five or six species from North America and Mexico. A large number of varieties have been selected in European gardens with pink and yellowish flowers and with odd habits of growth, such as vars. *fastigiata*, *inermis*, *mono-phylla*, *tortuosa*, etc. *R. hispida* and *R. viscosa* make handsome objects either as shrubs or grafted as low standards. Both are hardy to the lower lakes at least.

*Colutea* has three or more species from Europe and Asia. *C. arborescens* is extremely hardy and makes a small tree under favorable conditions.



WISTARIA CHINENSIS ALBA. (Standard.)

*Halimodendron argenteum* is monotypic and from Central Asia. It is grafted standard high upon the laburnum in English nurseries, and with it



silvery foliage, drooping habit and pinkish flowers is altogether a very interesting object. It has several varieties which are easily propagated, but little known.

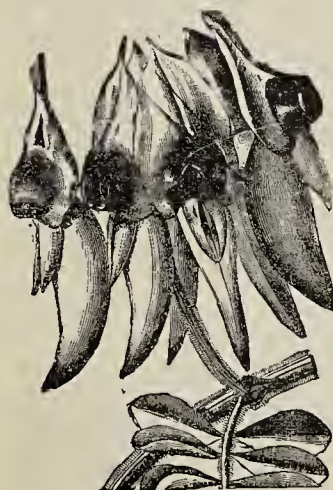
*Caragana* has fifteen species of small trees and shrubs from Central Asia and the Himalayas. *C. arborescens* and its pendulous variety are striking hardy small trees. Seven or eight others are in gardens.

*Calophaca* has seven species occurring from Western Asia, through the Caspian regions to India. The shrubby kinds are sometimes grafted by European nurserymen. *C. Wolgarica* is from Southern Russia and *C. grandiflora* from "Central Asia"; both are yellow flowered.

*Astragalus*, "milk vetch," has perhaps as many as 1,000 species, and it is believed even more names. They are pretty universal in the northern hemisphere, South America and South Africa. Some are annuals, some perennials, several trailers or climbers and a few are shrubby or suffrutescent. *A. tragacantha* is an evergreen shrub from Southern Europe; *A. monspessulanus* and its white variety are evergreen trailers from the same region.

*Oxytropis* has 200 species in Asia, Europe and North America. The Arctic *O. campestris* is one of the rarest British plants, having been found only near the White Water, at the head of the Clova, Angusshire, Scotland.

There are a great number of handsome, tender plants in the same tribe, among which may be mentioned *Clianthus*, *Sutherlandia*, *Swainsonia*,



CLIANTHUS. (Glory Pea.)

etc., many of which would do well in California.

Trenton, N. J.

James MacPherson.

Notes.

The red carnation is regarded in Spain as an emblem of despair. There is a tradition in Andalusia that the flower sprang from the blood of the Virgin Mary.

\* \* \*

The largest flower in the world is supposed to be the *Reafflesia Arnoldi*, discovered by Dr. Arnold in the Island of Sumatra during the early part of this century. It is a parasite, attaching itself to the roots of other plants, and is entirely destitute of leaves. A swelling beneath the bark of some huge surface-appearing root of a large tree announces the

coming of the flower. The bud, bursting through the bark, looks like a young cabbage. When fully opened the flower, green in color, measures thirty-nine inches in diameter, and its five great petals surround a cup-like calyx which holds six quarts of liquid.

\* \* \*

London is threatened with the loss of the Crystal palace, which for nearly two generations has been one of the most popular and widely known centers of amusement and of interest in the vicinity of the metropolis. The concern is hopelessly bankrupt, and, although the government is manifesting an anxiety to prevent its destruction, yet there seems to be no practical means of preserving this memorial of the first of the great international exhibitions of the nineteenth century.

\* \* \*

In the mountains of Venezuela grows a remarkable tree. It is found in rocky places, at heights of about half a mile. It is a stupid-looking tree enough at first sight. It is lofty and slender, and has stiff leaves that grow a foot or more in length. It looks much of the time as if it were dead. In those regions there is a wet and dry season, and during many months at a time not a shower washes its leaves. It bears very small, insignificant looking flowers. It is the milk tree, the famous "palo de vaca," cow tree, which Humboldt describes. He first brought it into notice. It is an evergreen. Its sap is a delicious fluid resembling the finest Jersey milk, only sweeter and richer than even that. When the negroes are thirsty they cut into the side of the trunk as one would bore into a maple for sugar water, and the milk gushes forth in a great stream. It is both food and drink, so rich is it. After a little time it grows thick and yellow, and a cream rises to the top. It has a fragrant odor. When a cow tree is tapped the natives hasten from all quarters with their bowls to catch the flow of milk. Sunrise is the best time to tap the tree, for then the sap flows most abundantly.

\* \* \*

Professor Maspero, the famous Egyptologist, is authority for the statement that among the royal mummies unbandaged in 1866 was one of a young man who had evidently been embalmed alive. The body had been tightly bound in three places, and then coated with bitumen, lime and pounded resin, and then wound from head to foot with bandages which had been soaked in some glutinous preparation. The agonized expression of the face and other evidences gave the scientists their clew. His age is about 23. The gold ornaments on his body indicated that he was of high rank, and likely the victim of some terrible tragedy.





THE BLATZ MAUSOLEUM, FOREST HOME CEMETERY, MILWAUKEE, WIS.

**The Blatz Mausoleum, Milwaukee, Wis.**

The Blatz Mausoleum, erected last year in Forest Home cemetery, Milwaukee, Wis., from designs of Mr. Chas. A. Fink, architect, is one of the recent examples of costly memorial architecture. It is constructed of Barre granite on a ground plan, the extreme dimensions of which are, 29 feet by 23 feet 9 inches, and it has a height of 30 feet. It is massive in every way, some exceptionally large stones having been used in its construction, and the ornamental features, moldings, reeds and festoons lend themselves to the solidity of appearance of the structure. The interior walls are of marble and the ceiling is of mosaic panels and marble ribs. It contains thirty catacombs and two in an Italian marble

sarcophagus, which rests on a Sienna marble slab placed in the centre of the vestibule. It is lighted by nine stained glass windows and it has bronze gates. It was built by the Milwaukee Monument Co., at a cost of about \$40,000.

---

The old George IV. tavern in Portugal street, London, which Dickens' commentators unite in saying is the house which the novelist described in "Pickwick", has just been sold at auction for \$37,750. It is not stated what its future will be, but such incidents remind one that in the many radical improvements carried out in London, very few of the spots made famous by Dickens remain.



**The Evergreen Magnolia.**

Many a visitor to the South returns to his home in the North enraptured with the beautiful *Magnolia grandiflora*, the royal evergreen of the South. And not only is this tree seen in its glory in the



south, in many part of Europe it is greatly prized. When visiting England two years ago, I saw it in many parts of that country. I found it grown considerably north of London. In almost every case it was grown fan shaped to a wall or dwelling, just as fruit trees are trained there, and as vines are here.

I saw it in this shape at Hampton Court Palace, the Royal Gardens, Kew, and at Queen Victoria's residence, Osborne. I am tempted to write of this tree at the present time because I am sure it can be grown much further north than is generally supposed. In a general way it is often said this tree cannot be grown north of Richmond. To prove to the contrary, readers are asked to look at the picture of the flowers presented herewith. These flowers were gathered from a tree growing almost on the brow of a hill at Roxborough, nearly the highest point in Philadelphia. The tree is thirty feet high, and it flowers and ripens seeds every year. It is not the only one by any means, to be found in this city. There is a very fine tree standing near the superintendent's house at Woodland Cemetery. I have never happened there at the flowering season, so cannot say that it blooms, but without a doubt it does. In Fairmount Park, near Horticultural Hall, there is a tree which has been flowering and seeding for many years. I could name a dozen trees thriving very well hereabout, several of them of flowering age. I would without hesitation lift the line of its hardiness from Richmond, Virginia, and set it at Philadelphia. As a matter of fact, Mr. Falconer told me some years

ago, that it lived out with him at Long Island. What it wants is a little sheltered place, shelter from the afternoon sun in winter being of importance for the sake of preserving its lovely green leaves. If given a place of this kind and a good mulching of forest leaves be placed about it, to keep the frost from penetrating to the roots, its leaves will be preserved all winter. In cases under my observation where no protection shade is afforded the foliage, it will be "scorched" badly on the southern side, but not on the northern, such as is often the case with rhododendrons. The ideal place for it would be where other evergreens or a large dwelling would keep the sunlight from it after mid-day in winter.

There is many a spot would exactly suit it in almost every park and public garden in the country. I have never known its wood to be hurt by frost but some years ago, in conversation with William Saunders, of the Agricultural Department, Washington, he told me that in the early 60's in an unusually severe winter, there were many large trees of it there killed to near the ground, but they grew again, forming a bush shape.

When the tree flowers, it is a rich treat to see it. On strong trees the blossoms are sometimes 8 inches in diameter and they are nice scented. At the base of the column of stamens there is a tinge of crimson, and the whole is beautifully set off by the luxuriant looking large green foliage.

I would recommend that plants be obtained from as far north as possible for northern planting, or from the mountain region of the south.

Philadelphia.

*Joseph Mechan.*

**Nelumbium Album Grandiflorum, Japan Lotus.**

It was our good pleasure the past season as never before to critically test the Japan Lotus, *N. album grandiflorum* and do not hesitate to say that it fully comes up to, if not surpasses our expectation both in freedom of bloom and impunity to stand rough usage. It is truly one of the floral aristocrats and whoever is fortunate enough to possess it, indeed has a treasure. We know of but one reason why this flower is not in general cultivation and that is because its extreme scarcity in this country has kept it from being known.

This grand flower being the largest, most prolific, most elastic to differences of temperature and the most chaste in color of all the lotuses, eminently deserves the highest rank among them, and this distinction is invariably made by all who are familiar with the different varieties. Both plant and foliage are stronger and more bulky than the Egyptian or American lotus; the flowers open out wider



and the petals are more numerous, wider and more rounded making the flower larger and heavier than that of any other variety. The blossoms rise but little above the leaves and often open amidst or beneath them—a habit peculiar to the Japan Lotus.

The color of the petals is a clear pearly white throughout, the outside of the outer ones softened with cream at their bases; the texture is uniform like that of *N. Roseum*. The stamens are long and numerous their color being a bright sulphur yellow; the seed pod is of the same rich color and stands out so as to give relief to the sparkling waxy white pistils. As a whole in richness of color and odor and size, exquisite attractiveness and magnificence, it outstrips the splendor of the world famous magnolia.

With us it has grown perfectly hardy in the southern provinces of Canada in open ponds. It is not a wild flower but does best when given strong cultivation especially in tubs and tanks where it becomes "pot bound." It also proves fairly satisfactory under glass but cannot be had to perfection this way. It blooms most freely after it has become established and somewhat crowded in its quarters.

This plant is a native of China and Japan where it now is and has ever been worshiped as the first flower of the land, and its culture dates back beyond the myths and legends of antiquity.

These nations have ever been famous for their inventive genius, and to the artistic eye the lotus is a prototype for almost every one of their advancements in art, architecture and agriculture. Believing as they did that the world emanated from the waters, it was natural for them to hold the water-lily as an emblem of the creation, because it rises from the waters and the deities were thought to have no other passage from their immortal abode to and from earth except through these mediums. Both Brahma and Buddha are said to have emanated from a lotus blossom and retired from earth through it.

Hence we can see how the lotus is held as the most sacred of plants and an emblem of perfection. They could fancy in its leaves an exact counterpart for silk, velvet, and the art of spinning and found in them a perfect model for the hat, the parasol, the fan, the drum and the plate, while from the large floating leaves—which often have mud deposited on them with small plants growing in it—they had a veritable floating garden in miniature while the lotus pond at night readily suggested the Japanese lantern.

This lotus, being pure white which was regarded as perfect—the god parent—and when associated with mortals it became corrupted with sin and pollution of the world which left stains and blotches on its fair face as a mark of supernatural displeasure. In

this way they account for the striped, blotched and red lotuses, which are its varieties.

Smiths Grove, Ky. *Geo. B. Moulder.*

The accompanying illustration is taken from a photograph of a water lily after a rain shower, but the reproduction does poor justice to a charming bit of nature, for in this case the rain drops literally



bespangled the leaves with jewels. We are indebted for the picture to Mr. Sid. J. Hare, superintendent of Forest Hill Cemetery, Kansas City, who with an eye to the beautiful, carries a camera, and is always on the alert to catch nature in her many attractive moods.

The centennial of the birth of Franz Siebold was recently celebrated in Japan by about 100 gentlemen, all but eighteen being Japanese. Siebold was the author of works upon Japan of high value, and in 1820 he was imprisoned in Yeddo for buying a map. He introduced lilies, camelias, peonies, and other Japanese plants into Europe.

The history of the Oleander, says *Meehan's Monthly* is almost co-eval with the history of the human race. It was the Rhododendron of the ancients, and when we read of the Rhododendron in the classical writings of the Greeks and Romans, the Oleander is to be understood. The Rhododendron, as we know it, was unknown to these ancients, so far as evinced by the writings that have come down to us. The flowers occupied a prominent place in their funeral practices, and were especially employed in the funeral ceremonies of females.

On the summit of Ben Lomond are the smallest trees in Great Britain. They are dwarf willows, and when mature are only about two inches in height.



## PARK NOTES

It is proposed to improve the forty acres about the Brooklyn, N. Y., Institute. Owing to lack of funds, however, no extensive scheme is at present contemplated.

\* \* \*

Charles Willard, Battle Creek, Mich., recently deceased, a few days before his death deeded that city sixteen acres of land on Goguc lake for a public park. By will he also bequeathed \$40,000 for the erection of a library building for the city schools and \$40,000 for a Young Men's Christian Association Building.

\* \* \*

The city attorney of Chattanooga, Tenn., in an opinion on the right of the Board of Public Works to cut down shade trees when in the way of grading, etc., reports that the board has the power so to do under the act, but is liable in damages to the owner of the trees which would be subject to rebate in proportion to benefit of said grading to owner of tree. When shade trees become dangerous from age or disease, they come under control of city and can be removed as a public necessity.

\* \* \*

The new Henry street schoolhouse, New York City, will be the largest school building in the country, making a block of 200 feet by 100 feet, five stories high, and having the unique feature of a roof garden as a play ground for the children nearly 100 feet from the street level. This play ground will be enclosed by a wire netting small enough in mesh to prevent anything from being cast into the street below. The building will cost over \$300,000 and will afford accommodation for 3,000 children.

\* \* \*

A magnificent gift to Los Angeles, Calif., has just been made by Mr. Griffith J. Griffith in the way of a tract of land comprising over 3,000 acres for a public park. It is situated just north of the city and is known as the Los Felis Rancho, including within its limits, bottom, foothill, ravine and mountainous land. It is a princely gift and will make Los Angeles, with the other parks already existing, one of the best provided cities in the country. It is to be hoped that the city fathers will be equally magnanimous in their appropriations for its care and maintenance.

\* \* \*

The New York Park Commissioners propose to establish a nursery for the purpose of raising suitable shade trees for beautifying the streets of the metropolis. The project is to set aside a suitable plot of ground on Washington Heights, and to set out hardy saplings of such kinds as will develop into thrifty shade trees, finally to be transplanted into the various city residence streets. The question of the proper care of shade trees in paved city streets is an important one, and one that is receiving considerable attention everywhere, the conditions surrounding city shade trees varying greatly, and involving special study.

\* \* \*

One of the most interesting and practical pieces of patriotic work accomplished lately by the Daughters of the American Revolution says an exchange, is the planting of thirteen trees sent from the thirteen original states to the Sequoia Chapter of San Francisco, Cal. These have been planted in the form of an arch, 450 feet long, in Golden Gate Park, each one from some noted battle-ground or historical spot. From the Valley Forge camping-ground in Pennsylvania came a cypress, which is placed in the centre as the keystone of the arch. New Jersey sent a linden from the Wallace House, Washington's headquarters in 1778; Connecticut, a scion of the famous charter oak; Massachu-

setts, an elm from the old North Bridge of Concord; New York, a white-oak from the battle-ground of Saratoga; and each of the other pioneer states forwarded a different specimen of equal interest.

\* \* \*

Mr. D. H. Burnham has again presented some views concerning the proposed parking of the lake shore of the city of Chicago to the Park Commissioners, and has pointed out the possibilities to be achieved by properly improving the splendid opportunity. Many cities of the old world have become famous besides being permanent attractions to a large influx of the traveling public, by public improvements which have taken centuries, perhaps, to develop, and are now reaping the material benefits of such travel. In the case of Chicago, the development of this ideal lake front of an enormous city, which could be accomplished in comparatively few years, would make it altogether a marvel of nineteenth century city development, and would undoubtedly make it one of the greatest attractions of home and foreign travel. The possibilities are so apparent and the benefits equally so, that it may be assumed that the progressive spirit that has dominated the city's growth will not lightly pass over this great project.

\* \* \*

In the public hearings on the draft of the charter of "Greater New York" in regard to the Park Department. Mr. Elhu Root, counsel for the Fine Arts Federation, presented a chapter drawn by the Federation as a substitute for the section relating to artistic supervision over works of art to be placed in the parks. According to the *New York Evening Sun*, it provided that there should be a Commission composed of the Mayor, the President of the Metropolitan Museum of Art, the President of the New York Public Library, Astor, Lenox and Tilden foundations, the President of the Brooklyn Institute of Arts and Science, and six others to be appointed by the Mayor from a list to be submitted to him by the art societies. Of the six Commissioners to be appointed by the Mayor one should be a sculptor, one a painter, one an architect and three citizens who are not professionals. It is also provided that the head of any city Department may serve as a member of this Commission on all matters relating to his particular Department. No statue or other work of art is to be accepted by the city to be placed in any park or public building until it has been approved of by this Commission.

\* \* \*

At a recent session of the Onandaga, (N. Y.) County Farmers' Club, held in Syracuse, Mr. W. W. Newman, secretary of the Onandaga County Cemetery Association, read a paper on "Inexpensive Rural Ornaments, or Lawns, Trees, Shrubs and Flowers." The paper was a broad plea for the more general use of trees and plants for the adornment of the house, as well as touching upon their peculiarities and describing their several requirements and methods of caring for them. Among the quotations given as emphasizing the subject is the following from Donald G. Mitchell, in "My Farm of Englewood:" "There will always be in every moderately free country a great class of small landholders, in whose hands will lie, for the most part, the control of our rural landscape and the fashioning of our wayside homes; and when they shall take pride, as a body, in giving grace to these homes the country will have taken a long step forward in the refinements of civilization. I may make my home, however small it be, so complete in its simplicity, so fitted to its offices, so governed by neatness, so embowered by leaf and flower, that no wealth in the world could add to it without damaging its rural grace; and my gardeners—Sunshine, Frost and Showers are their names—shall work for me with no crusty reluctance, but with an abandon and zeal that ask only gratitude for pay."



## CEMETERY NOTES.

Mrs. Allyn, widow of Robert Allyn, has given to the Spring Grove Cemetery Association, Cincinnati, O., the Allyn memorial constructed in memory of the late ex Mayor T. M. Allyn.

\* \* \*

A Senate bill has been approved by the committee at Washington allowing the managers of Graceland cemetery to put a mortgage upon the property in order to provide funds for the removal of the bodies, it being impossible to sell portions of the land until this is accomplished. The board of managers had no legal power to act without such authority.

\* \* \*

One of Chicago's enterprising dailies has been investigating the reason for harvesting so large a crop of ice from the ponds in Oakwoods Cemetery. The officials at the cemetery claimed it to be largely used in their extensive green houses, and that even the employes do not use it to any great extent. Avoid all appearance of evil is an injunction of broad application.

\* \* \*

There is a permanently growing interest in regard to the condition of the cemeteries in many localities. In Concord, N. H., fifteen years ago there were but seven trust funds in the hands of the city authorities for the improvement of any of the cemeteries, now there are ninety-two, a fact worthy of note. An appeal is made to the benevolence of those who while living elsewhere, still arrange for their last home in Blossom Hill, to provide in the near future for an appropriate memorial chapel. Here is a noble opportunity for a permanent memorial.

\* \* \*

The annual report of Mountain View Cemetery, Oakland, Calif., gives total receipts for 1896, \$57,736.10; total expenditures \$35,064.68. Lots to the number of 139 were sold for \$12,984.70, and 570 single graves for \$2,620.00. The amount placed to the Perpetual Care fund was \$11,982.40 making a total of \$60,226.50. Many improvements were made during the year, among them a number of handsome vaults and monuments, including the Elks monument—a bronze life-size elk, mounted on a pedestal of onyx, with base of natural rocks among which plants and creeping vines are planted.

\* \* \*

The annual meeting of the Little Lake Cemetery Company Peterborough, N. H., held January 18, showed receipts of \$3,621.40 and expenditures of \$2095.81. The receipts were less than in any of the previous four years. Superintendent W. H. Foord's report shows receipts from the sale of lots and single graves of \$1107.40. It also displays commendable efforts to place the cemetery on the lines of modern improvement. Only a few iron fences around lots remain and the report recommends putting the grave markers down to a level with the ground. Many improvements are being carried out tending to the permanent improvement of the cemetery.

\* \* \*

In St. Louis Sunday funerals are being seriously discouraged. In December last the Bellefontaine Cemetery Association began the closing of its city office on Sunday and issued notices prohibiting the digging of graves on that day and requiring that all orders for Sunday funerals be left at the city office by noon on Saturday. Last month a further advance in cemetery work was made at that cemetery by orders that all corner and boundary stones should be set flush with the ground, and that all plans and designs for stone work must receive the approval of

the general superintendent before commencement of work. In Germantown, Philadelphia, the Ivy Hill Cemetery Co., issued the following notice on October last: On and after November 1, 1896, an additional charge of Five Dollars will be made for funerals that take place on Sundays.

\* \* \*

Mr. Thaddeus Foster, assistant superintendent of Hollywood Cemetery, Richmond, Va., met with an accident in that cemetery on the morning of January 22, which resulted in his death on the evening of the same day. Although in his 73rd year he was an exceedingly active man, and was at work in the cemetery directing the limbing of some large oak trees, when the men, losing control of an immense branch, it fell, striking Mr. Foster unconscious to the ground. He was removed to his home, rallied and appeared to be rapidly recovering when he was suddenly prostrated in the evening and quickly breathed his last. He was one of Richmond's oldest, best known and most highly esteemed citizens, and a veteran of two wars. He had occupied his position in the Hollywood cemetery for ten years. He leaves a wife and five grown-up children.

\* \* \*

In the death of Linus Graves, Bloomington, Ill., loses one of its pioneer business men and the Evergreen Cemetery Association an active and interested official, who originally platted the cemetery and becoming superintendent, secretary and treasurer, retained these offices until stricken with paralysis last July. The association then elected his son Arthur J. Graves to the office of superintendent, and his son-in-law J. C. Means to that of secretary and treasurer. He was born in Williamstown, Vermont, and his family was one of the oldest in the United States, tracing back to 1060 when his ancestors left France for England, and later in 1640 the first of them reached America. He was a warm friend of Abraham Lincoln. He was identified with all public movements for the improvement of Bloomington, the city of the living, dating from its infancy to its present conditions, as well as in its city of the dead, Evergreen cemetery.

\* \* \*

The New York law giving a lien on a tombstone for the purchase money has been declared unconstitutional by the Supreme Court of that state. The court in its decision says: "The act in question is almost without precedent in the legislative history of the State. It confers upon the lieners the right to go upon the plaintiff's burying ground and dig up and remove the monument and sell it at public auction without the consent of the owner. In removing the monument they may desecrate the graves and disturb the remains. . . . Every civilized country regards the resting place of the dead as hallowed ground, and not subject to liens and to be sold upon execution like ordinary property. Courts of equity have always been ready to restrain those who threaten to desecrate the graves of the dead and to protect the sentiment of natural affection which the surviving kindred and friends entertain for their departed relatives."

\* \* \*

The Marcus and Amherst Cemetery Association, Marcus, Ia., has issued a circular to its lot owners treating mainly of Perpetual Care and appealing forcibly to them to consider the important question. The circular states that the association, last year, attempted "the care of the whole cemetery on the lawn plan, giving the same care to all occupied parts of the grounds, and attending to the unoccupied parts sufficiently to preserve the appearance of the whole. The experiment proved that, for a trifling expense, each lot may be kept in repair, the newly made graves can be sodded, weeds kept down and the grass mowed and trimmed on lots, walks and drives, at a merely nominal cost." This was a commendable experiment



which should inspire the lot owners to unite in creating a fund for the perpetual care of the cemetery. Modern cemetery ideas are making strong headway, and need only sustained effort to establish them.

\* \* \*

The annual report of Swan Point cemetery, Providence, R. I., shows total receipts \$91,206.97 which includes \$15,453 from sale of lots, labor and material \$15,648.01, tomb rent \$476.52. The total expenditures were 96,323.47 of which \$25,414.74 was expended for labor and \$7,100 for salaries. The average number of men employed per month was 50. The number of interments was 251 making a total to Dec. 31, 1896 of 13,751. There were 271 foundations to monuments and tablets constructed. Two headstones, and four curbingings were removed from lots. Out of the whole number of lots sold to date, 3193, 1409 are under perpetual care, 529 under annual care and 282 under partial care. The perpetual care and bequest fund now amounts to \$250,235.15.

\* \* \*

The sixty-fifth annual meeting of the proprietors of Mount Auburn Cemetery, Boston, was held Feb. 1st. The total receipts from all sources for the year were \$189,791, which with the balance from last year equals \$239,007. The expenditures were \$214,239. 546 interments were made during the year of which 36 were removals. The total number of interments now exceed 31,407. The perpetual care fund amounts to \$897,413, a gain of 43,441 during the past year. The permanent fund for the care of the cemetery after all lots are sold amounts to \$364,461. The principal improvement commenced during the year are a chapel and office structure connected with it. The chapel fronts on Central avenue. The main entrance to the chapel is through a covered porch. The extreme length of the building from the fronts of this porch to the rear wall of the chancel is 116 feet, and the extreme width across the transept 54 feet. The office building has a frontage of 55 feet and a depth of 65 feet, and is connected with the chapel by a cloister, which also extends along the north wall of the chapel. The English perpendicular style of architecture as exemplified in many of the English parish churches built during the early part of the fifteenth century has been adopted, and the chapel has been planned to meet the requirements of all religious denominations.

## Correspondence.

FRANKLIN, PA., February, 1897.

*Editor Park and Cemetery:*

DEAR SIR:—I fully endorsed all Mr. Stone said in your last about the St. Louis convention. Many of us in our smaller cemeteries can scarcely hope for the opportunity of expressing our appreciation in the same way; but while I live it will always be pleasant to remember the days we spent in that city under the care of Supt. Brazill and his associates. Those in charge of the publication of our proceedings deserve the thanks of the members. The publication impresses the value of the convention on us by affording us an opportunity for home study and contemplation, besides the pleasure of recalling the interesting matters of the convention.

I would like to ask the Ladies' of the Association of Bloomington, Ind., through PARK AND CEMETERY, whether they have any auxiliaries, or papers for starting new associations. I think our Ladies would join them in such work; they have assisted me in many ways, and are a great help. I expected be-

fore this to have seen some notes from Mr. Salway concerning his trip to the old country. I am sure he would observe many things of interest to us, if he had the time to jot them down.

The citizens of Franklin have recently erected a fine fountain in the park to the memory of the late Dr. A. G. Egbert, and as soon as I can I will forward you a photograph and particulars. January was our busiest month for the year, having had more burials than in any other month of the year.

C. D. Phipps.  
Supt. Franklin Cemetery.

FORT PLAIN, N. Y., January 29, 1897.

*Editor Park and Cemetery.*

DEAR SIR:—I have no information to contribute to our useful paper at present, but if you can advise me on the question of who has a right to vote at the election of trustees of a cemetery association I should be obliged. Of course a person can vote by proxy but can anyone who is not a direct lot owner vote on account of his brothers, sisters, or any near relatives lot, even if the direct owner is away or dead. Any information in this line I think would be interesting to all who are not rightly posted.

W. C. Rapp,  
Superintendent, Fort Plain Cemetery.

[The laws of the state usually regulate the descent of heirship in cemetery property. The question of voting in elections of officers, or matters pertaining to the cemetery management is subject to the laws of the organization itself.—EDS.]

### Reforms at Funerals.

The two most painful periods for mourners at funerals are undoubtedly: first, when the body is being lowered into the grave; the second and most trying especially for female friends, being that when the earth clods, falling upon the coffin as each shovel full is thrown in, gives back such unearthly hollow sounds so unlike any other, and which frequently ring in the ears for days.

It is in the power of the cemetery officials to mitigate this feature by not filling in until after the friends have taken their departure from the grave side. The writer has adopted the following method which with the co-operation of the undertakers works well.

Along each side of the grave are laid dressed and painted planks 2 in. by 12 in. and 12 feet in length, resting at either end upon 2 in by 4 in. dressed scantling. These planks make it easy for the carriers to deposit the coffin over the grave. The remains being lowered, and the religious or other services ended, the attendants after allowing a minute or two for a last fond look, quietly slip the planks over the opening and all is hidden from view. The undertaker leads the chief mourners away to their carriages, the others soon follow and after all have departed, the attendants can fill the grave without undue haste. The work can be better performed when there are no onlookers to embarrass.



### Association of American Cemetery Superintendents.

G. W. CREESY, "Harmony Grove,"  
Salem, Mass., President.

ARTHUR W. HOBERT, "Lakewood,"  
Minneapolis, Minn., Vice-President.

F. EURICH, Woodlawn, Toledo, O.,  
Secretary and Treasurer.

### Publishers' Department.

Park Commissioners and Cemetery trustees are requested to send us copies of their reports.

Photographs and descriptive sketches of interesting features in parks and cemeteries are solicited from our readers.

The advance proofs of the report of the Minnesota Interstate Park Commissioner, Mr. Geo. H. Hazzard, of St. Paul, Minn., are to hand. The report in connection with the pamphlet containing Lectures, Laws, Papers, Pictures and Pointers of the Interstate Park about the Dalles of the St. Croix in the vicinity of Taylor's Falls, Minn., and St. Croix Falls, Wis., displays an energy and resources in pushing so worthy a project alike creditable to Mr. Hazzard and to the governor's wisdom in appointing him commissioner. Notwithstanding the activity displayed in exploiting the scheme, a rigid economy marks the financial showing, and the work done surely points to an early consummation of the proposed park, which aside from the beauty and re creative resources of the locality will lend itself to the preservation of many natural objects peculiar to the states interested. Such a park project should receive every consideration of the state legislatures and liberal provision should be made to ensure its early preparation for the objects which its characteristics clearly suggest.

The U. S. Civil Service Commission held an annual examination on Feb. 10th, in Washington, D. C., and other cities where there were applicants, to fill a vacancy in the position of expert horticulturist, Office of Experiment Stations, Department of Agriculture, the salary of which is \$1,400 per annum. The subjects of the examination were as follows: Theory and practice of horticulture; Translation of technical French; Translation of technical German, Abstracting of the literature of horticultural research; Essay writing on a given horticultural subject.

Sid. J. Hare, Supt., Forest Hill Cemetery, Kansas City, Mo., reports the following amusing incident: Since the trees

have dropped their foliage, we see them as they have never appeared to us when clothed in verdure. A visitor at Forest Hill Cemetery, last week approached the superintendent and asked, Why do you plant so many of your trees with the roots up? I know of none here was the reply of the superintendent. The visitor insisted that he was right and said that he saw them all along the main drive and near the entrance with the roots up and the stem and top planted in the ground—come I will show you! The trees proved to be fine specimens of "Teas Weeping Mulberry." The visitor cleared himself by saying, I know you are always trying some new scheme, and thought you were trying one here.

An exchange gives the following as the text of a card of thanks handed in by a bereaved woman: "I desire to thank the friends and neighbors most heartily in this matter for the united aid and co-operation during the illness and death of my husband, who escaped from me by the hand of death last Friday while eating breakfast. To the friends and all who contributed so willingly towards making the last moments and funeral of my husband a success I desire to thank most kindly, hoping these few lines will find them enjoying the same blessing. I have also a good milch cow, and a roan gelding horse of eight years old which I will sell cheap. God moves in a mysterious way His wonders to perform. Also a black and white shoat very low.

#### RECEIVED.

Oakland Cemetery Association, St. Paul, Minn., Annual Report of the Trustees to the lot-owners, for year ending Oct. 31, 1896. Contains also extracts from state laws interesting to lot-owners.

Circular No. 1. The Marcus and Amherst Cemetery Association, Marcus, Ia. Information to lot owners on Perpetual Care, etc.

#### CATALOGUES.

An especially valuable feature of the catalogue of Thomas Meehan & Sons, Nurserymen and Landscape Engineers, Germantown, Philadelphia, Pa., is the practical chapter on the planting and pruning of trees and shrubs. The catalogue itself is a valuable addition to the library, in that it gives so much information on the trees and plants described in its pages. Reliable information in such catalogues is of unmistakable service, and a great timesaver, and the extent of the nurseries and variety of products of the Messrs. Meehan, make their annual worthy of particular attention.

The General Catalogue of Fruit and Ornamental Trees, Shrubs, Roses, etc., of Ellwanger & Barry, Mount Hope Nurseries, Rochester, N. Y., for 1897, as usual does credit to a great establishment. The catalogue which is freely illustrated from specimens on the grounds contains Meritorious Novelties, Part I: Fruit Department; Part II, Ornamental Department. The extent of the work of these nurseries may, in a measure, be estimated from the wealth of products described in the 150 pages of matter, and the fifty years of growth, the fiftieth anniversary being celebrated this year, serves to attest the reputation of the firm independent of the vast services it has rendered to horticultural development. The Ellwanger & Barry catalogue should be another welcome addition to the library of those interested.

Among the new and rare things described in the valuable catalogue just issued by the Storrs & Harrison Company Palmsville, Ohio, are the giant orchid flowered Cannas, Austria and Italia. They reveal the wonderful capacity for development inherent in some of our ordinary species of flowers in the hands of skillful manipulators. This firm carry a full line of everything for the orchard, lawn, garden and greenhouse, and publish a comprehensive catalogues.

Catalogue of Cannas, Gladioli, Clivias, H. H. Groff, Simcoe, Ontario, Canada.

Catalogue of Novelties and Specialties of the Universal Horticultural Establishment, W. A. Manda, South Orange, N. J.

Spring of 1897. Catalogue and Price list of the Evergreen Nurseries. Evergreen Nursery Co., Evergreen, Door Co., Wis. Evergreens, Rare and Choice Deciduous and Ornamental Trees, Shrubs, and Plants. Fruit Trees, etc.

Wholesale Catalogue of the Waukegan Nurseries, Waukegan, Ill. R. Douglas & Sons, 1896-1897. New and Rare Evergreens, Deciduous Trees, etc.

Trade List Morris Floral Company, Morris, Illinois. Novelties for 1897.

Messrs C. Hanika & Sons, Muncie, Ind., have issued catalogue No. 15 of Vases, Chairs, Settees and other architectural ironwork for parks and cemeteries. The catalogue is profusely illustrated and contains a large number of handsome designs up-to-date and attractive, with accompanying descriptive matter and other information.

#### TESTIMONIALS.

I find PARK AND CEMETERY a great help to me, and always full of news.—*Sid J. Hare Supt.*, Forest Hill Cemetery, Kansas City, Mo.















